

# ***OWNER'S MANUAL***



***2025  
ADX***

# General Information

## California Proposition 65 Warning

 **WARNING:** Operating, servicing and maintaining a passenger vehicle or off-highway motor vehicle can expose you to chemicals including engine exhaust, carbon monoxide, phthalates, and lead, which are known to the State of California to cause cancer and birth defects or other reproductive harm. To minimize exposure, avoid breathing exhaust, do not idle the engine except as necessary, service your vehicle in a well-ventilated area and wear gloves or wash your hands frequently when servicing your vehicle. For more information go to [www.P65Warnings.ca.gov/passenger-vehicle](http://www.P65Warnings.ca.gov/passenger-vehicle).

## A Few Words About Safety

Your safety, and the safety of others, is very important. Operating this vehicle safely is an important responsibility.

To help you make informed decisions about safety, we have provided operating procedures and other information on labels and in this manual. This information alerts you to potential hazards that could hurt you or others.

Of course, it is not practical or possible to warn you about all the hazards associated with operating or maintaining your vehicle. You must use your own good judgment. You will find this important safety information in a variety of forms, including:

- **Safety Labels** - on the vehicle.
- **Safety Messages** - preceded by a safety alert symbol  and one of three signal words: **DANGER**, **WARNING**, or **CAUTION**. These signal words mean:

### **DANGER**

You **WILL** be **KILLED** or **SERIOUSLY HURT** if you don't follow instructions.

### **WARNING**

You **CAN** be **KILLED** or **SERIOUSLY HURT** if you don't follow instructions.

## CAUTION

You CAN be HURT if you don't follow instructions.

- **Safety Headings** - such as Important Safety Precautions.
- **Safety Section** - such as Safe Driving.
- **Instructions** - how to use this vehicle correctly and safely.

This entire book is filled with important safety information - please read it carefully.

## About Other Displays



This mark denotes advice for preventing vehicle damage or malfunction, or that you should be careful when using something.



Indicates that a feature is customizable.

## About This Manual

This owner's manual should be considered a permanent part of the vehicle and should remain with the vehicle when it is sold.

This owner's manual covers all models of your vehicle. You may find descriptions of equipment and features that are not on your particular model.

The images throughout this owner's manual (including the front cover) that depict features, equipment, Audio/Information screen details, and Meter screens are only examples and may not be representative of your particular model.

This owner's manual is for vehicles sold in the United States and Canada.

The information and specifications included in this publication were in effect at the time of approval for printing. Honda Motor Co., Ltd. reserves the right, however, to discontinue or change specifications or design at any time without notice and without incurring any obligation.

## System Updates Terms and Conditions\*

General

\*: Not available on all models

Your vehicle has an application that allows your 9" Color Touchscreen with Google built-in to automatically search for Acura software updates that are specific to your 9" Color Touchscreen with Google built-in and its connected devices (initially every one (1) week via Wi-Fi or every four (4) weeks via Telematics Control Unit (TCU), queries may occur more or less frequently due to internet outages, retries, direct user action, WAP push from the server, or a change in query policy on the Honda servers). This application periodically transmits to our servers a limited amount of vehicle and device information (Vehicle Identification Number (VIN), the Model Type (MT) Identification Number, Hardware and Software Part Number, Serial Number, Software Version, preferred language, Internet Protocol (IP) address, Transaction Log (alert or update viewing, update download and installation, software status), etc.). When the application finds an update from the server, the application initially asks permission to download and install the update. Where available, in your settings menu you may elect to automatically download and install these updates or you may elect to manually update the system.

When your 9" Color Touchscreen with Google built-in searches our servers for updates or alerts, we will automatically provide you with the opportunity to update your devices or transmit the update or alert directly to your 9" Color Touchscreen with Google built-in. We will also maintain on our servers a log of the updates or alerts that are installed.

### Your Personal Data

Should the aforementioned information transmitted to Honda constitute personal information in your region, please note that this information will be treated in strict accordance with the rules and regulations outlined in this notice as well as applicable data protection law.

The terms of our privacy notice are incorporated into these terms by reference and your use of system updates will be subject to the privacy notice. Our privacy notice sets out information about how we and any named third-parties will process any personal data we collect from you or that you provide to us, via the application. For further details, see Acura's vehicle data privacy notice at:

U.S.: [www.acura.com](http://www.acura.com)

Canada: <https://www.honda.ca/privacy/vehicledata> (English)

<https://www.honda.ca/fr/confidentialite/politiquedeconfidentialite> (French)

Honda collects, uses, and stores your personal data for the reasons set out below:

- to deliver the system updates and related services to you;
- to allow us to improve and optimize the system updates products and services;
- to respond to user questions and complaints; and for internal record keeping.
- where necessary for Honda's legitimate interests, as listed below, and where our interests are not overridden by your data protection rights.
- as otherwise described in Honda's Privacy Notice and Vehicle Data Privacy Notice.

Protecting our legitimate business interests and legal rights includes, but is not limited to, use in connection with compliance, regulatory, auditing, legal claims (including disclosure of such information in connection with legal process or litigation), and other ethics and compliance reporting requirements. Honda will also convert personal data into anonymous data and use it (normally on an aggregated statistical basis) for uses such as market research and analysis, to improve the system updates, to analyze trends, and to assess the success of software update releases. Aggregated personal information does not personally identify you or any other use of the system updates.

Honda may share this data with Honda's worldwide support organization or affiliated Honda companies or other third parties engaged by Honda for the purposes of rendering support services in connection with system support.

## Event Data Recorders

### **This vehicle is equipped with an event data recorder (EDR).**

The main purpose of an EDR is to record, in certain crash or near crash-like situations, such as an air bag deployment or hitting a road obstacle, data that will assist in understanding how a vehicle's systems performed. **The EDR is designed to record data related to vehicle dynamics and safety systems for a short period of time, typically 30 seconds or less. The EDR in this vehicle is designed to record such data as:**

- **How various systems in your vehicle were operating;**
- **Whether or not the driver and passenger safety belts were buckled/fastened;**
- **How far (if at all) the driver was depressing the accelerator and/or brake pedal; and,**
- **How fast the vehicle was traveling.**

These data can help provide a better understanding of the circumstances in which crashes and injuries occur. NOTE: EDR data are recorded by your vehicle only if a non-trivial crash situation occurs; no data are recorded by the EDR under normal driving conditions and no personal data (e.g., name, gender, age, and crash location) are recorded. However, other parties, such as law enforcement, could combine the EDR data with the type of personally identifying data routinely acquired during a crash investigation.

To read data recorded by an EDR, special equipment is required, and access to the vehicle or the EDR is needed. In addition to the vehicle manufacturer, other parties, such as law enforcement, that have the special equipment, can read the information if they have access to the vehicle or the EDR.

The data belongs to the vehicle owner and may not be accessed by anyone else except as legally required or with the permission of the vehicle owner.

## Service Diagnostic Recorders

This vehicle is equipped with service-related devices that record information about powertrain performance. The data can be used to verify emissions law requirements and/or help technicians diagnose and solve service problems. It may also be combined with data from other sources for research purposes, but it remains confidential. Some diagnostic and maintenance information is uploaded to Honda upon vehicle start up.

### ▼ Canadian models

## Vehicle Data Recordings

This vehicle records the following information as data when the Collision Mitigation Braking System™ (CMBS™) is operated.

- Images of objects in front of the vehicle when the CMBS™ is activated
- Operational status of each function of the CMBS™
- Accelerator/brake pedal operation
- Vehicle speed
- Information such as distance and relative speed of the target identified by the CMBS™ when activated

Honda may obtain and use the recorded data for the purpose of technical diagnosis and research and development of Honda vehicles.

The CMBS™ does not record images or audio inside the vehicle.

Special tools are required to review or remove data (including images) recorded by CMBS™.

The CMBS™ image recording function can be turned off so that no images are recorded when CMBS™ is activated.

Disclosure of data

Honda will not disclose or provide the acquired data to third parties with data recorded by CMBS™ except in the following cases:

- When the owner of the vehicle consents
- When required by law, court order, or similar legally enforceable request
- When the data has been processed to de-identify/anonymize the vehicles/users, such as when aggregate data is provided to research institutions

## California Perchlorate Contamination Prevention Act

The airbags, seat belt tensioners, and CR type batteries in this vehicle may contain perchlorate materials - special handling may apply. See [www.dtsc.ca.gov/hazardouswaste/perchlorate](http://www.dtsc.ca.gov/hazardouswaste/perchlorate)

## Software End User License Agreement

Your vehicle comes equipped with software, which is governed by the End User License Agreement in this Owner's Manual, and which contains a binding arbitration clause. Please refer to the End User License Agreement for the terms and conditions governing your use of the installed software, as well as the applications, services, functions, and content provided through the software. Your use of the installed software will serve as your consent to the terms and conditions of the End User License Agreement.

You may opt out within 30 days of your initial use of the Software by sending a signed, written notice to Acura at American Honda Motor Co., Inc., Acura Client Relations, Mail Stop CHI-4, 1919 Torrance Blvd., Torrance, CA 90501-2746.

## Privacy Notice

This vehicle may share location and usage information. To manage this setting, visit at:

U.S.: <https://mygarage.honda.com/s/vehicle-data-privacy-settings?page=question>

Canada: <https://www.honda.ca/privacy/vehicledata> (English)

<https://www.honda.ca/fr/confidentialite/politiquedeconfidentialite> (French)

**To learn more about how we collect and use Personal Information including precise geolocation data, please read our Privacy Notice and Vehicle Data Privacy Notice, accessible at:**

**U.S.: [www.acura.com](http://www.acura.com)**

**Canada: [www.acura.ca](http://www.acura.ca) (English)**

**[www.acura.ca/fr](http://www.acura.ca/fr) (French)**

# Contents

<b>1</b>	<b>Before Driving</b>	<b>13</b>
Check Before Driving ▶ <b>14</b>   Safety Labels ▶ <b>47</b>   Key ▶ <b>48</b>   Locking/Unlocking ▶ <b>54</b>   Steering Wheel ▶ <b>67</b>   Seats ▶ <b>68</b>   Seat Belts ▶ <b>77</b>   Mirrors ▶ <b>85</b>   Windows ▶ <b>87</b>   Tailgate ▶ <b>90</b>   Maximum Load Limit ▶ <b>97</b>   Towing a Trailer ▶ <b>100</b>   Off-Highway Driving Guidelines ▶ <b>101</b>		
<b>2</b>	<b>Driving Operation</b>	<b>103</b>
Starting or Stopping the Engine ▶ <b>104</b>   Shifting ▶ <b>110</b>   Braking ▶ <b>113</b>   Starting and Driving ▶ <b>120</b>   Parking Your Vehicle ▶ <b>122</b>   Rear View Camera ▶ <b>123</b>   Multi View Camera System ▶ <b>125</b>   Refueling ▶ <b>133</b>   Fuel Economy and CO. Emissions ▶ <b>136</b>   Turbo Engine Vehicle ▶ <b>137</b>   Turn Signals · Light Switches ▶ <b>138</b>   Wipers and Washers ▶ <b>145</b>   Defroster ▶ <b>149</b>   Heated Windshield Button ▶ <b>151</b>   Driving Features ▶ <b>152</b>		
<b>3</b>	<b>Controls</b>	<b>165</b>
Interior Lights ▶ <b>167</b>   Interior Convenience Items ▶ <b>169</b>   Front Seat Heaters/Ventilators ▶ <b>177</b>   Heated Steering Wheel ▶ <b>179</b>   Moonroof/Panoramic Roof ▶ <b>180</b>   Climate Control System ▶ <b>184</b>   In-Vehicle Infotainment ▶ <b>188</b>   9" Color Touchscreen ▶ <b>199</b>   9" Color Touchscreen with Google built-in ▶ <b>218</b>   General Information on the Audio System ▶ <b>259</b>		
<b>4</b>	<b>Safety Driving Assist System</b>	<b>277</b>
AcuraWatch™ ▶ <b>278</b>   Collision Mitigation Braking System™ (CMBS™) ▶ <b>284</b>   Low Speed Braking Control ▶ <b>291</b>   Road Departure Mitigation System ▶ <b>296</b>   Adaptive Cruise Control (ACC) with Low Speed Follow ▶ <b>300</b>   Lane Keeping Assist System (LKAS) ▶ <b>310</b>   Traffic Jam Assist ▶ <b>314</b>   Traffic Sign Recognition System ▶ <b>319</b>   Blind Spot Information System ▶ <b>323</b>   Cross Traffic Monitor ▶ <b>326</b>   Parking Sensor System ▶ <b>330</b>		
<b>5</b>	<b>About Your Instrument Panel</b>	<b>334</b>
Indicators ▶ <b>335</b>   Gauges ▶ <b>342</b>   Driver Information Interface ▶ <b>346</b>		
<b>6</b>	<b>Maintenance</b>	<b>357</b>
Before Performing Maintenance ▶ <b>358</b>   Maintenance Minder™ ▶ <b>361</b>   Maintenance Under the Hood ▶ <b>366</b>   Checking and Maintaining Wiper Blades ▶ <b>376</b>   Checking and Maintaining Tires ▶ <b>378</b>   12-Volt Battery ▶ <b>387</b>   Climate Control System Maintenance ▶ <b>389</b>   Cleaning ▶ <b>390</b>		
<b>7</b>	<b>Handling the Unexpected</b>	<b>393</b>
Tools ▶ <b>394</b>   When a Lightbulb Goes Out ▶ <b>396</b>   Remote Transmitter Care ▶ <b>397</b>   If a Tire Goes Flat ▶ <b>399</b>   Engine Does Not Start ▶ <b>412</b>   If the 12-volt Battery Is Dead ▶ <b>415</b>   Shift Lever Does Not Move ▶ <b>417</b>   Overheating ▶ <b>418</b>   When a Warning Appears ▶ <b>420</b>   Fuses ▶ <b>421</b>   Emergency Towing ▶ <b>427</b>   If You Cannot Unlock the Fuel Fill Door ▶ <b>428</b>   If You Cannot Open the Tailgate ▶ <b>429</b>   Refueling ▶ <b>430</b>   Emergency Call (eCall) ▶ <b>431</b>		
<b>8</b>	<b>Vehicle Information</b>	<b>433</b>
Specifications ▶ <b>434</b>   Identification Numbers ▶ <b>436</b>   Devices that Emit Radio Waves ▶ <b>437</b>   Reporting Safety Defects ▶ <b>438</b>   Emissions Testing ▶ <b>440</b>   Warranty Coverages ▶ <b>441</b>   Authorized Manuals ▶ <b>443</b>   Client Service Information ▶ <b>444</b>   Open Source License ▶ <b>446</b>		

1

2

3

4

5

6

7

8

Index

\*: Not available on all models



# Visual Index



<b>1</b> Maintenance Under the Hood	▶ 366
<b>2</b> Windshield Wipers	▶ 145
<b>3</b> Front Wide View Camera	▶ 280
<b>4</b> Power Door Mirrors	▶ 85
Side Turn Signal/Emergency Indicator Lights	▶ 138
	▶ 396
<b>5</b> Door Lock/Unlock Control	▶ 54
<b>6</b> Tires	▶ 378
	▶ 399
<b>7</b> Headlights	▶ 138
	▶ 396
Front Turn Signal Lights	▶ 138
	▶ 396
Parking/Chicane™ Daytime Running Lights	▶ 138
	▶ 141
	▶ 396
Front Side Marker Lights	▶ 138
	▶ 396
<b>8</b> Fog Lights*	▶ 141
	▶ 396

<b>9</b> Multi View Camera System*	▶ 125
<b>10</b> How to Refuel	▶ 134
<b>11</b> High-Mount Brake Light	▶ 396
<b>12</b> Rear Wiper	▶ 147
	▶ 377
<b>13</b> Opening/Closing the Tailgate	▶ 90
<b>14</b> Rear License Plate Light	▶ 396
Tailgate Release Button	▶ 91
<b>15</b> Rear View Camera*	▶ 123
Multi View Camera System*	▶ 125
<b>16</b> Chicane™ Taillights	▶ 138
	▶ 396
Back-Up Lights	▶ 396
<b>17</b> Brake Lights	▶ 396
Rear Side Marker/Chicane™ Taillights	▶ 138
	▶ 396
Rear Turn Signal Lights	▶ 138
	▶ 396

\*: Not available on all models

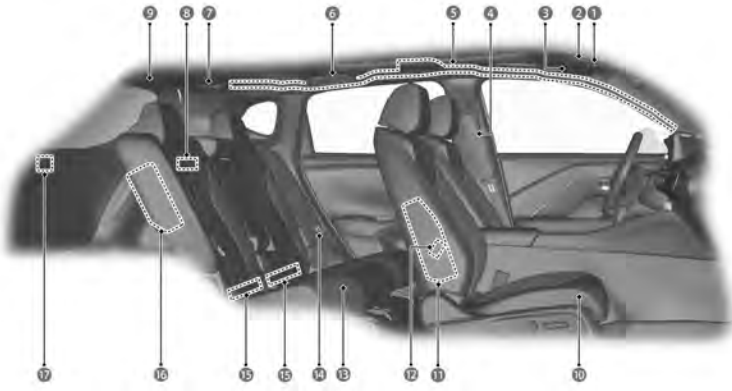

<b>1</b>	Interior Light	▶ 167
	Map Lights	▶ 168
<b>2</b>	Moonroof/Panoramic Roof Switch	▶ 180 ▶ 181
	<b>SOS</b> Button	▶ 432
	Sunglasses Holder	▶ 174
<b>3</b>	Sun Visors	
	Vanity Mirrors	
<b>4</b>	Seat Belts	▶ 77
<b>5</b>	Side Curtain Airbags	▶ 42
<b>6</b>	Grab Handles	
	Coat Hook	▶ 173
<b>7</b>	Interior Lights	▶ 167
	Map Lights	▶ 168

<b>8</b>	Cargo Area Lights	
<b>9</b>	Seat Belt with Detachable Anchor	▶ 82
<b>10</b>	Front Seat	▶ 70
<b>11</b>	Front Side Airbags	▶ 40
<b>12</b>	USB Ports*	▶ 192
<b>13</b>	Rear Seat	▶ 72
<b>14</b>	Seat Belt (Installing a Child Seat)	▶ 25
	Seat Belt to Secure a Child Seat	▶ 27
<b>15</b>	LATCH to Secure a Child Seat	▶ 23
<b>16</b>	Rear Side Airbags	▶ 40
<b>17</b>	Accessory Power Socket	▶ 169

\*: Not available on all models

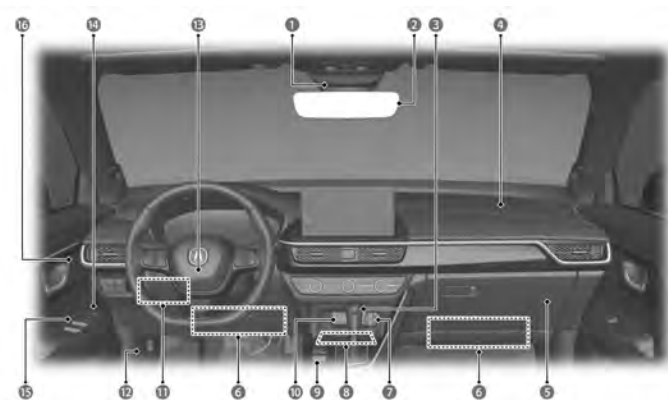









<b>1</b>	Passenger Airbag Off Indicator	▶ 44
<b>2</b>	Rearview Mirror	▶ 85
<b>3</b>	Shift Lever	▶ 110
<b>4</b>	Passenger's Front Airbag	▶ 35
<b>5</b>	Glove Box	▶ 169
<b>6</b>	Knee Airbags	▶ 39
<b>7</b>	Accessory Power Socket	▶ 169
<b>8</b>	Wireless Charger	▶ 170
<b>9</b>	<b>Dynamic Mode</b> Switch	▶ 152
	Auto Idle Stop <b>OFF</b> Button	▶ 156
	Hill Descent Control Button	▶ 159
	Electric Parking Brake Switch	▶ 114
	Automatic Brake Hold Button	▶ 117

<b>10</b>	USB Ports	▶ 192
<b>11</b>	Interior Fuse Box	▶ 423 ▶ 424
<b>12</b>	Hood Release Handle	▶ 366
<b>13</b>	Driver's Front Airbag	▶ 35
<b>14</b>	Door Mirror Controls	▶ 85
<b>15</b>	Master Door Lock Switch	▶ 63
	Power Window Switches	▶ 87
<b>16</b>	Driving Position Memory System Buttons*	▶ 75

\*: Not available on all models



1	System Indicators	▶ 335
	Gauges	▶ 342
	Driver Information Interface	▶ 346
2	<b>ENGINE START/STOP</b> Button	▶ 104
3	Audio System	▶ 188
4	 Hazard Warning Button	
5	 Front Seat Heater/ Ventilators` Buttons	▶ 177
6	Climate Control System	▶ 184
	 <b>ON/OFF</b> Button	▶ 185
	 Front Defogger	▶ 149
	 Rear Defogger/ Heated Door Mirror Button	▶ 149

7	Steering Wheel Adjustments	▶ 67
8	 Power Tailgate Button	▶ 93
	 Vehicle Stability Assist™ (VSA®) System <b>OFF</b> Button	▶ 161
	 Heated Windshield Button*	▶ 151

\*: Not available on all models

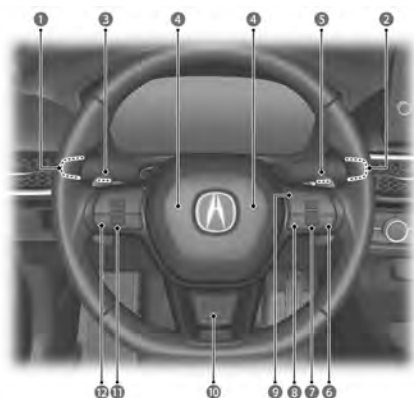

1	Headlights	▶ 138
	Turn Signals	▶ 138
	Fog Lights*	▶ 141
2	Wipers/ Washers	▶ 145
	<b>CAMERA</b> Button*	▶ 126
3	Paddle Shifter (Shift down)	▶ 111
4	Horn (Press an area around )	
5	Paddle Shifter (Shift up)	▶ 111
6	Lane Keeping Assist System (LKAS) Button	▶ 311
7	Right Selector Wheel	▶ 346
8	Interval Button	▶ 304
9	Adaptive Cruise Control (ACC) with Low Speed Follow Buttons	▶ 301
10	Heated Steering Wheel Button*	▶ 179
11	Left Selector Wheel	▶ 194

12	(Talk) Button	▶ 207
		▶ 209
		▶ 224
		▶ 237
		▶ 237
		▶ 240
		▶ 240
		▶ 241
	Audio Remote Controls	▶ 193

\*: Not available on all models

# Before Driving

## Check Before Driving

For Safe Driving	14
Important Handling Information	15
Your Vehicle's Safety Features	16
Driving Preparation	17
Precautions While Driving	19
Child Safety	19
Safety of Infants and Small Children	20
Installing a Child Seat	23
Safety of Larger Children	29
Exhaust Gas Hazard	31
Modifications and Accessories	32
About Your Airbags	33
Airbag System Components	34
Front Airbags (SRS)	35
Knee Airbags	39
Side Airbags	40
Side Curtain Airbags	42
Airbag System Indicators	43
Airbag Care	45

## Safety Labels

Label Locations	47
-----------------	----

## Key

Details on the Key	48
Built-in Key	52
Key Number Tag	52

## Locking/Unlocking

Using the Remote Transmitter	54
Using the Keyless Access System	55
Locking the Doors and Tailgate (Walk Away Auto Lock*)	58
Lock Presetting	59
Unlocking the Doors Using a Key	60
Locking a Door Without Using a Key	60
Checking Door Lock Status*	62
Locking/Unlocking the Doors from the Inside	63
Auto Door Locking/Unlocking	64
Childproof Door Locks	65

\*: Not available on all models

What to Do If	65
---------------	----

## Steering Wheel

Adjusting the Steering Wheel	67
------------------------------	----

## Seats

Adjusting the Seat	68
Adjusting the Front Seat Positions	70
Adjusting the Rear Outer and Center Seat Positions	72
Driving Position Memory System*	74
Rear Seat Reminder	76

## Seat Belts

About Your Seat Belts	77
Fastening a Seat Belt	80
Adjusting the Shoulder Anchor	82
Seat Belt with Detachable Anchor	82
Seat Belt Inspection	83

## Mirrors

Interior Rearview Mirror	85
Power Door Mirrors	85

## Windows

Opening/Closing the Power Windows	87
Opening the Windows with the Remote	88

## Tailgate

Precautions for Opening/Closing the Tailgate	90
Opening/Closing the Power Tailgate	91

## Maximum Load Limit

About Maximum Load Limit	97
Label Example	97
Load Limits Example	98

## Towing a Trailer

About Towing a Trailer	100
Towing Behind a Motorhome	100

## Off-Highway Driving Guidelines

General Information	101
Important Safety Precautions	101
Avoiding Trouble	102

# Check Before Driving

## For Safe Driving

The following pages explain your vehicle's safety features and how to use them properly. The safety precautions below are ones that we consider to be among the most important.

### Important Safety Precautions

Some states, provinces, and territories prohibit the use of cell phones other than hands-free devices by the driver while driving.

#### Always wear your seat belt

A seat belt is your best protection in all types of collisions. Airbags are designed to supplement seat belts, not replace them. So even though your vehicle is equipped with airbags, make sure you and your passengers always wear your seat belts, and wear them properly.

#### Restrain all children

Children ages 12 and under should ride properly restrained in a back seat, not the front seat. Infants and small children should be restrained in a child seat. Larger children should use a booster seat and a lap/shoulder seat belt until they can use the belt properly without a booster seat.

#### Be aware of airbag hazards

While airbags can save lives, they can cause serious or fatal injuries to occupants who sit too close to them, or are not properly restrained. Infants, young children, and short adults are at the greatest risk. Be sure to follow all instructions and warnings in this manual.

#### Don't drink and drive

Alcohol and driving don't mix. Even one drink can reduce your ability to respond to changing conditions, and your reaction time gets worse with every additional drink. So don't drink and drive, and don't let your friends drink and drive, either.

#### Pay appropriate attention to the task of driving safely

Engaging in cell phone conversation or other activities that keep you from paying close attention to the road, other vehicles, and pedestrians could lead to a crash. Remember, situations can change quickly, and only you can decide when it is safe to divert some attention away from driving.

## Control your speed

Excessive speed is a major factor in crash injuries and deaths. Generally, the higher the speed, the greater the risk, but serious injuries can also occur at lower speeds. Never drive faster than is safe for current conditions, regardless of the maximum speed posted.

## Keep your vehicle in safe condition

Having a tire blowout or a mechanical failure can be extremely hazardous. To reduce the possibility of such problems, check your tire pressures and condition frequently, and perform all regularly scheduled maintenance.

## Do not leave children unattended in the vehicle

Children, pets, and people needing assistance left unattended in the vehicle may be injured if they activate one or more of the vehicle controls. They may also cause the vehicle to move, resulting in a crash in which they and/or another person(s) can be injured or killed. Also, depending on the ambient temperature, the temperature of the interior may reach extreme levels, which can result in harm or death. Even if the climate control system is on, never leave them in the vehicle unattended as the climate control system can shut off at any time.

## Important Handling Information

Your vehicle has higher ground clearance than a passenger vehicle designed for use only on pavement. Higher ground clearance has many advantages for off-highway driving. It allows you to travel over bumps, obstacles, and rough terrain. It also provides good visibility so you can anticipate problems earlier.

These advantages come at some cost. Because your vehicle is taller and rides higher off the ground, it has a higher center of gravity making it more susceptible to tipping or rollover if you make abrupt turns. Utility vehicles have a significantly higher rollover rate than other types of vehicles. In a rollover crash, an unbelted person is significantly more likely to die than a person wearing a seat belt. As a reminder, make sure you and your passengers always wear seat belts.

For information on how to reduce the risk of rollover, read:

[Q Driving Guidelines for Your Utility Vehicle ▶ P.121](#)

[Q General Information ▶ P.101](#)

Failure to operate your vehicle correctly might result in a crash or a rollover.



## Your Vehicle's Safety Features

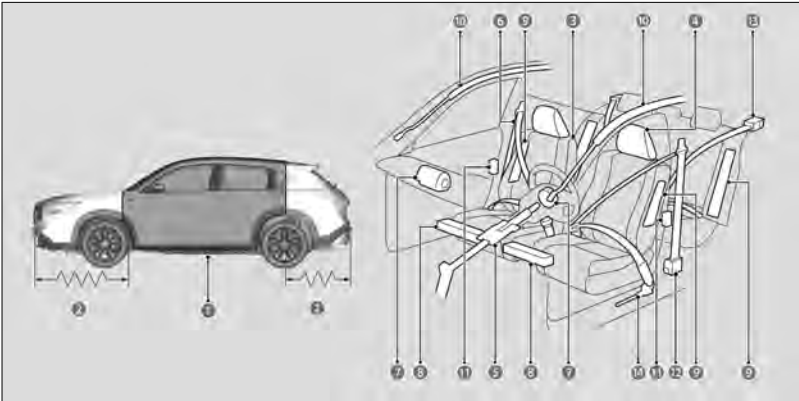

- 1 Safety Cage
- 2 Crush Zones
- 3 Seats and Seat-Backs
- 4 Head Restraints
- 5 Collapsible Steering Column
- 6 Seat Belts
- 7 Front Airbags
- 8 Knee Airbags
- 9 Side Airbags
- 10 Side Curtain Airbags
- 11 Door Locks
- 12 Seat Belt Tensioners (Front Seats)
- 13 Seat Belt Tensioners (Rear Seats)
- 14 Outer Lap Pretensioners

The following checklist will help you take an active role in protecting yourself and your passengers.

Your vehicle is equipped with many features that work together to help protect you and your passengers during a crash.

Some features do not require any action on your part. These include a strong steel framework that forms a safety cage around the passenger compartment, front and rear crush zones, a collapsible steering column, and tensioners that tighten the front and outer rear seat belts in a sufficient crash.

However, you and your passengers cannot take full advantage of these features unless you remain seated in the correct position and always wear your seat belts. In fact, some safety features can contribute to injuries if they are not used properly.

## Driving Preparation

### Exterior Checks

- Make sure there are no people or objects behind or around the vehicle.
  - » There are blind spots from the inside.
- Make sure the tires are in good condition.
  - » Check air pressures, and check for damage and excessive wear.
    - Q **Checking Tires** ▶P.378
- Make sure the hood is securely closed.
  - » If the hood opens while driving, your front view will be blocked.
- Make sure there are no obstructions on the windows, door mirrors, exterior lights, or other parts of the vehicle.
  - » Remove any frost, snow, or ice.
  - » Remove any snow on the roof, as this can slip down and obstruct your field of vision while driving or fall off and impact other road users. If frozen solid, remove ice once it has softened.
  - » When removing ice from around the wheels, be sure not to damage the wheel or wheel components.
- Make sure the door is not frozen.
  - » When doors are frozen shut, use warm water around the door edges to melt any ice. Do not try to force them open, as this can damage the rubber trim around the doors. When done, wipe dry to avoid further freezing.
- Make sure that there are no flammable materials left under the hood.
  - » Be especially careful if the vehicle has not been used for a long time, or after maintenance. The heat from the engine and exhaust may cause flammable materials to catch fire, leading to unexpected accidents.

### Interior Checks

- After everyone has entered the vehicle, be sure all doors and the tailgate are closed and locked. Locking the doors and the tailgate helps prevent an occupant from being ejected and an outsider from unexpectedly opening a door or the tailgate.

Q **Locking/Unlocking the Doors from the Inside** ▶P.63



- If the door and/or tailgate open message appears on the driver information interface, a door and/or the tailgate is not completely closed. Close all doors and the tailgate tightly until the message disappears.

- Adjust your seat to a position suitable for driving. Be sure the front seats are adjusted as far to the rear as possible while allowing the driver to control the vehicle. Sitting too close to a front airbag can result in serious or fatal injury in a crash.

 [Adjusting the Front Seat Positions](#) ▶ P.70

 [Adjusting the Seat](#) ▶ P.68

- Adjust head restraints to the proper position. Head restraints are most effective when the center of the head restraint aligns with the center of your head. Taller persons should adjust their head restraint to the highest position.

 [Adjusting the Front Seat Positions](#) ▶ P.70

- Always wear your seat belt, and make sure you wear it properly. Confirm that any passengers are properly belted as well.

 [Fastening a Seat Belt](#) ▶ P.80

- Protect children by using seat belts or child seats according to a child's age, height, and weight.

 [Child Safety](#) ▶ P.19

- Do not place anything in the front seat footwells. Make sure to secure the floor mat.

» An object or unsecured floor mat can interfere with your brake and accelerator pedal operation while driving.

- Store or secure all items on board properly.

» Carrying too much cargo, or improperly storing it, can affect your vehicle's handling, stability, stopping distance, and tires, and make it unsafe.

- Do not pile items higher than the seatback height.

» They can block your view and may be thrown forward in the event of sudden braking.

- Adjust the mirrors and steering wheel properly.

» Adjust them while sitting in the proper driving position.

 [Interior Rearview Mirror](#) ▶ P.85

 [Power Door Mirrors](#) ▶ P.85

 [Adjusting the Steering Wheel](#) ▶ P.67

- Be sure items placed on the floor behind the front seats cannot roll under the seats.

» They can interfere with the driver's ability to operate the pedals, the operation of the seats, or the operation of the sensors under the seats.

- If you have any animals on board, do not let them move around in the vehicle.

» They may interfere with driving and a crash could occur.

- Make sure that the indicators in the instrument panel come on when you start the vehicle, and go off soon after.

» Always have a dealer check the vehicle if a problem is indicated.

 [Indicator List](#) ▶ P.335

The headlight aim is set by the factory, and does not need to be adjusted. However, if you regularly carry heavy items in the cargo area or tow a trailer, have the aiming readjusted at a dealer or by a qualified technician.

## Precautions While Driving

### In Rain

Avoid driving in deep water and on flooded roads. This can damage the engine or driveline, or cause electrical component failure.

### Other Precautions

If there is a strong impact with something under the vehicle, stop in a safe location. Check the underside of the vehicle for damage or any fluid leaks.

If you repeatedly turn the steering wheel at an extremely low speed, or hold the steering wheel in the full left or right position for a while, the electric power steering (EPS) system heats up, causing the system to go into a protective mode and make the steering wheel progressively harder to operate.

- » Once the system cools down, the EPS system is restored.
- » Repeated operation under these conditions can eventually damage the system.

## Child Safety

### Protecting Child Passengers

Each year, many children are injured or killed in vehicle crashes because they are either unrestrained or not properly restrained. In fact, vehicle crashes are the number one cause of death of children ages 12 and under.

To reduce the number of child deaths and injuries, every state and Canadian province and territory requires that infants and children be properly restrained when they ride in a vehicle.

Children should sit properly restrained in a rear seat. This is because:

- An inflating front airbag can injure or kill a child sitting in the front seat.
- A child in the front seat is more likely to interfere with the driver's ability to safely control the vehicle.
- Statistics show that children of all sizes and ages are safer when they are properly restrained in a rear seat.



- Never hold a child on your lap because it is impossible to protect them in the event of a collision.

- Never put a seat belt over yourself and a child. During a crash, the belt would likely press deep into the child and cause serious or fatal injuries.
- Never let two children use the same seat belt. Both children could be very seriously injured in a crash.
- Any child who is too small to wear a seat belt correctly must be restrained in an approved child seat that is properly secured to the vehicle using either the seat belt or the lower anchors of the LATCH system.
- Do not allow children to operate the doors, windows, or seat adjustments.
- Do not leave children in the vehicle unattended, especially in hot weather when the inside of the vehicle can get hot enough to kill them. They could also activate vehicle controls causing it to move unexpectedly.

The National Highway Traffic Safety Administration and Transport Canada recommend that all children ages 12 and under be properly restrained in a rear seat. Some states or provinces/territories have laws restricting where children may ride. To remind you of the passenger's front airbag hazards and child safety, your vehicle has warning labels on the dashboard (U.S. models) and on the front visors. Please read and follow the instructions on these labels.

To deactivate a lockable retractor, release the buckle and allow the seat belt to wind up all the way.

### **WARNING**

Allowing a child to play with a seat belt or wrap one around their neck can result in serious injury or death.

Instruct children not to play with any seat belt and make sure any unused seat belt a child can reach is buckled, fully retracted, and locked.

### **WARNING**

Children who are unrestrained or improperly restrained can be seriously injured or killed in a crash.

Any child too small for a seat belt should be properly restrained in a child seat. A larger child should be properly restrained with a seat belt, using a booster seat if necessary.

## **Safety of Infants and Small Children**

### **Protecting Infants**

An infant must be properly restrained in a rear-facing child seat until the infant reaches the seat manufacturer's weight or height limit for the seat.

## Positioning a rear-facing child seat



Child seats must be placed and secured in a rear seating position.

Experts recommend use of a rear-facing seat for a child so long as the child's height and weight are appropriate for a rear-facing seat.

Infants should never be seated in a forward-facing position.

Always refer to the child seat manufacturer's instructions before installation.

Do not allow a front seat to rest against a child seat installed in a rear seating position.

The weight sensor in the front seat may not correctly detect the actual weight of the occupant.

When properly installed, a rear-facing child seat may prevent the driver or a front passenger from moving their seat all the way back, or from locking their seat-back in the desired position. Make sure that there is no contact between the child seat and the seat in front of it.

It can also interfere with proper operation of the passenger's advanced front airbag system.

### About Your Airbags ▶ P.33

If this occurs, we recommend that you install the child seat directly behind the front passenger's seat, move the seat as far forward as needed, and leave it unoccupied. Or, you may wish to get a smaller rear-facing child seat.

## WARNING

Placing a rear-facing child seat in the front seat can result in serious injury or death during a crash.

Always place a rear-facing child seat in the rear seat, not the front.

## Protecting Smaller Children

If a child has exceeded the weight and height limitations of a rear-facing child seat, the child should be properly restrained in a firmly secured forward-facing child seat until they exceed the weight and height limitations for the forward-facing child seat. Educate yourself about the laws and regulations regarding child seat use where you are driving, and follow the child seat manufacturer's instructions.

## Forward-facing child seat placement



We strongly recommend placing a forward-facing child seat in a rear seating position.

Placing a forward-facing child seat in the front seat can be hazardous, even with advanced front airbags that automatically turn the passenger's front airbag off. A rear seat is the safest place for a child.

### **⚠ WARNING**

Placing a forward-facing child seat in the front seat can result in serious injury or death if the front airbag inflates.

If you must place a forward-facing child seat in front, move the vehicle seat as far back as possible, and properly restrain the child.

## Selecting a Child Seat

Most child seats are LATCH-compatible (Lower Anchors and Tethers for Children). Some have a rigid-type connector while others have a flexible-type connector. Both are equally easy to use. Some existing and previously owned child seats can only be installed using the seat belt. Whichever type you choose, follow the child seat manufacturer's use and care instructions including recommended expiration dates as well as the instructions in this manual. Proper installation is key to maximizing your child's safety.

In seating positions and vehicles not equipped with LATCH, a LATCH-compatible child seat can be installed using the seat belt and a top tether for added security. This is because all child seats are required to be designed so that they can be secured with a lap belt or the lap part of a lap/shoulder belt. In addition, the child seat manufacturer may advise that a seat belt be used to attach a LATCH-compatible seat once a child reaches a specified weight. Please read the child seat owner's manual for proper installation instructions.

### Important consideration when selecting a child seat

- The child seat is the correct type and size for the child.
- The child seat is the correct type for the seating position.
- The child seat is compliant with Federal Motor Vehicle Safety Standard 213 or Canadian Motor Vehicle Safety Standard 213.

LATCH-compatible child seats have been developed to simplify the installation process and reduce the likelihood of injuries caused by incorrect installation.

## Installing a Child Seat

### Installing a LATCH-Compatible Child Seat

A LATCH-compatible child seat can be installed in either of the two outer rear seats. A child seat is attached to the lower anchors with either the rigid or flexible type of connectors.

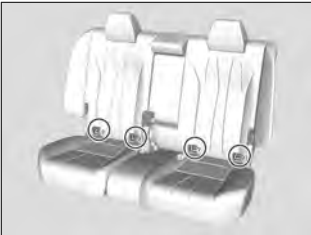

The location of each lower anchor is shown in the illustration.



- [1] Place the child seat on the vehicle seat, then attach the child seat to the lower anchors according to the instructions that came with the child seat.

» When installing the child seat, make sure that the lower anchors are not obstructed by the seat belt or any other object.

- 1 Rigid Type
- 2 Lower Anchors



- 1 Flexible Type
- 2 Lower Anchors



### ▼ Straight top tether type



- 1 Anchor
- 2 Tether Strap Hook

### ▼ Other top tether type



- 1 Anchor
- 2 Tether Strap Hook

- [2] Raise the head restraint to its highest position.
  - » Remove the cargo area cover\*.

**Q Cargo Area Cover\* ▶P.174**
- [3] Route the tether strap between the head restraint legs.
  - » If the child seat is unstable due to interference from the head restraint, raise the head restraint or remove it if possible.Make sure the strap is not twisted.
- [4] Secure the tether strap hook to the anchor.
- [5] Tighten the tether strap as instructed by the child seat manufacturer.
- [6] Make sure the child seat is firmly secured by rocking it forward and back and side to side; little movement should be felt.
- [7] Make sure any unused seat belt that a child can reach is buckled, the lockable retractor is activated, and the belt is fully retracted and locked.

## ⚠ WARNING

Using the outer rear seats' inner anchors to secure a LATCH-compatible child seat in the center seating position may result in failure of the child seat, causing injury or death.

Only use the outer rear seats' inner anchors to install a child seat in the center seating position if the manufacturer's instructions expressly permit.

### Installing a LATCH-compatible child seat in the rear center seat

Each outer rear seat is equipped with a pair of lower anchors which are used to secure a LATCH-compatible child seat. The rear center seat, however, is not equipped with anchors of any kind.

The inner and outer anchors are spaced apart at a standard distance of 11 inches (280 mm). The distance between the two inner anchors is 16.1 inches (410 mm).

\*: Not available on all models

LATCH-compatible restraint systems that are fitted with rigid-type attachments cannot be installed in the rear center seat. However, a system fitted with flexible-type attachments can be installed in the center seat, provided that the manufacturer's instructions for that system permit the use of the inner anchors with the stated spacing.

Before seating a child, make sure that the system is properly attached to both the lower anchors and tether anchors.

For your child's safety, when using a child seat installed using the LATCH system, make sure that the child seat is properly secured to the vehicle.

A child seat that is not properly secured will not adequately protect a child in a crash and may cause injury to the child or other vehicle occupants.

### **⚠ WARNING**

Never attach two child seats to the same anchor. In a collision, one anchor may not be strong enough to hold two child seat attachments and may break, causing serious injury or death.

## **Installing a Child Seat with a Lap/Shoulder Seat Belt**

A child seat can be installed with a lap/shoulder belt in any rear seat or, if absolutely necessary, the front passenger seat.



- [1] Place the child seat on the vehicle seat.
  - » When affixing a child seat to the front passenger's seat, slide the passenger's seat all the way back. If the child seat is unstable due to interference from the head restraint, raise the head restraint or remove it if possible.
- [2] Route the seat belt through the child seat according to the seat manufacturer's instructions, and insert the latch plate into the buckle.
  - » Insert the latch plate fully until it clicks.



- [3] Slowly pull the shoulder part of the belt all the way out until it stops. This activates the lockable retractor.
- [4] Let the seat belt retract a few inches and check that the retractor has switched modes by pulling on the webbing. It should not pull out again until it is reset by removing the latch plate from the buckle.
  - » If you are able to pull the shoulder belt out, the lockable retractor is not activated. Slowly pull the seat belt all the way out, and repeat steps 3 – 4.



- [5] Grab the shoulder part of the seat belt near the buckle, and pull up to remove any slack from the lap part of the belt.

» When doing this, place your weight on the child seat and push it into the vehicle seat.



- [6] Make sure the child seat is firmly secured by rocking it forward and back and side to side; less than one inch of movement should occur near the seat belt.
- [7] Make sure any unused seat belt that a child can reach is buckled, the lockable retractor is activated, and the belt is fully retracted and locked.

A child seat that is not properly secured will not adequately protect a child in a crash and may cause injury to the child or other vehicle occupants.

To deactivate a lockable retractor, release the buckle and allow the seat belt to wind up all the way.

## Adding Security with a Tether

### ▼ Outer position



### 1 Tether Anchor Points

### ▼ Center position



### 1 Tether Anchor Point

A tether anchor point is provided behind the rear outer seating positions and in the ceiling for the rear center.

If you have a child seat that comes with a tether but can be installed with a seat belt, the tether may be used for additional security.

Always use a tether for forward-facing child seats whether using the seat belt or lower anchors.

## Using an outer anchor

### ▼ Straight top tether type



- 1 Anchor
- 2 Tether Strap Hook

- [1] Raise the head restraint to its highest position.
    - » Remove the cargo area cover\*.
  - [2] Route the tether strap between the head restraint legs.
    - » If the child seat is unstable due to interference from the head restraint, raise the head restraint or remove it if possible.
- Make sure the strap is not twisted.
- [3] Secure the tether strap hook to the anchor.
  - [4] Tighten the tether strap as instructed by the child seat manufacturer.

 Cargo Area Cover\*  P.174

### ▼ Other top tether type



- 1 Anchor
- 2 Tether Strap Hook

\*: Not available on all models

## Using the center anchor

### ▼ Straight top tether type

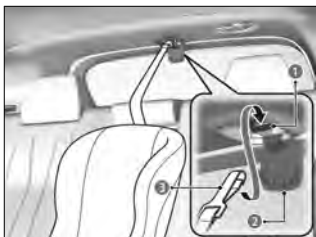

- [1] Lower the head restraint to its lowest position.
- [2] Open the anchor cover.
- [3] Route the tether strap over the head restraint. Make sure the strap is not twisted.
- [4] Secure the tether strap hook to the anchor.
- [5] Tighten the tether strap as instructed by the child seat manufacturer.

- 1 Anchor
- 2 Anchor Cover
- 3 Tether Strap Hook

### ▼ Other top tether type

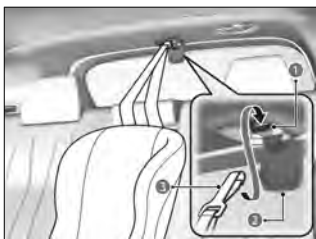

- 1 Anchor
- 2 Anchor Cover
- 3 Tether Strap Hook

## Safety of Larger Children

### Protecting Larger Children

The following pages give instructions on how to check proper seat belt fit, what kind of booster seat to use if one is needed, and important precautions for a child who must sit in front.

### Checking Seat Belt Fit

When a child is too big for a child seat, secure the child in a rear seat using the lap/shoulder seat belt. Have the child sit upright and all the way back, then answer the following questions.

## Checklist



- Do the child's knees bend comfortably over the edge of the seat?
- Does the shoulder belt cross between the child's neck and arm?
- Is the lap part of the seat belt as low as possible, touching the child's thighs?
- Will the child be able to stay seated like this for the whole trip?

If you answer yes to all these questions, the child is ready to wear the lap/shoulder seat belt correctly. If you answer no to any question, the child needs to ride on a booster seat until the seat belt fits properly without a booster seat.

## Booster Seats



If a lap/shoulder seat belt cannot be used properly, position the child in a booster seat in the rear seat. For the child's safety, check that the child meets the booster seat manufacturer's recommendations.

- When installing a booster seat, make sure to read the instructions that came with it, and install the seat accordingly. There are high- and low-type booster seats. Choose a booster seat that allows the child to wear the seat belt correctly.

Some U.S. states and Canadian provinces and territories require children to use a booster seat until they reach a given age or weight (e.g., 6 years or 60 lbs). Be sure to check current laws in the state, province, or territory where you intend to drive.

## Protecting Larger Children - Final Checks

Your vehicle has a rear seat where children can be properly restrained. If you ever have to carry a group of children, and a child must ride in front:

- Make sure you read and fully understand the instructions and safety information in this manual.
- Move the front passenger seat as far back as possible.
- Have the child sit upright and well back in the seat.
- Check that the seat belt is properly positioned so that the child is secure in the seat.

## Monitoring child passengers

We strongly recommend that you keep an eye on child passengers. Even older, more mature children sometimes need to be reminded to fasten their seat belts and sit up properly.

### WARNING

Allowing a child age 12 or under to sit in front can result in injury or death if the passenger's front airbag inflates.

If a larger child must ride in front, move the vehicle seat as far to the rear as possible, have the child sit up properly and wear the seat belt properly, and use a booster seat if needed.

## Exhaust Gas Hazard

### Carbon Monoxide Gas

The engine exhaust from this vehicle contains carbon monoxide, a colorless, odorless, and highly toxic gas. As long as you properly maintain your vehicle, carbon monoxide gas will not get into the interior.

#### Have the exhaust system inspected for leaks whenever

- The exhaust system is making an unusual noise.
- The exhaust system may have been damaged.
- The vehicle is raised for an oil change.

When you operate a vehicle with the tailgate open, airflow can pull exhaust gas into the interior and create a hazardous condition. If you must drive with the tailgate open, open all the windows and set the climate control system as shown below.

- [1] Select the fresh air mode.
- [2] Select the  mode.
- [3] Set the fan speed to high.
- [4] Set the temperature control to a comfortable setting.

Adjust the climate control system in the same manner if you sit in your parked vehicle with the engine running.

### WARNING

Carbon monoxide gas is toxic.

Breathing it can cause unconsciousness and even kill you.

Avoid any enclosed areas or activities that expose you to carbon monoxide.





Do not run the engine with the garage door closed.

An enclosed area such as a garage can quickly fill up with carbon monoxide gas. Even when the garage door is open, drive out of the garage immediately after starting the engine.

## Modifications and Accessories

### Modifications

- Do not modify your vehicle in a manner that may affect its handling, stability, or reliability, or install non-Genuine Acura parts or accessories that may have a similar effect.
- Even minor modifications to vehicle systems can affect overall vehicle performance.
- Always make sure all equipment is properly installed and maintained, and do not make any modification to your vehicle or its systems that might cause your vehicle to no longer meet federal, state, province, territory, and local regulations.
- The on-board diagnostic port (OBD-II/SAE J1962 connector) installed on this vehicle is intended to be used with automobile system diagnostic devices or with other devices that Acura has approved. Use of any other type of device may adversely affect the vehicle's electronic systems or allow them to be compromised, possibly resulting in a system malfunction, drained the 12-volt battery, or other unexpected problems.
- Do not modify or attempt to repair any of the electrical components.

### WARNING

Improper accessories or modifications can affect your vehicle's handling, stability, and performance, and cause a crash in which you can be seriously hurt or killed.

Follow all instructions in this owner's manual regarding accessories and modifications.



Acura Genuine Accessories are recommended to ensure proper operation of your vehicle.

### Accessories

When installing accessories, check the following:

- Do not install accessories on the windshield. They can obstruct your view and delay your reaction to driving conditions.
- Do not install any items other than Acura Genuine Accessories designated for your vehicle over areas containing airbags.  
Items other than Acura Genuine Accessories designated for your vehicle installed in these areas may interfere with proper operation of the vehicle's airbags or may be propelled into you or another occupant if the airbags deploy.

- Be sure electronic accessories do not overload electrical circuits or interfere with proper operation of your vehicle.

 [Checking Fuses](#) ▶ P.421

- Before installing any electronic accessory, have the installer contact a dealer for assistance. If possible, have a dealer inspect the final installation.

If any Acura Genuine Accessories become inoperable, refer to the separate accessory owner's manual (if applicable) or consult a dealer for assistance to troubleshoot the potential faulty condition.

## About Your Airbags

Your vehicle is equipped with four types of airbags:

- Front airbags: Airbags in front of the driver's and front passenger's seats.
- Knee airbags: Airbags under the steering column and under the glove box.
- Side airbags: Airbags in the driver's and front passenger's outer seat-backs and next to the outer rear seating positions.
- Side curtain airbags: Airbags above the side windows.

Each is discussed in the following pages.

The airbags can inflate whenever the power mode is in ON.

After an airbag inflates in a crash, you may see a small amount of smoke. This is from the combustion process of the inflator material and is not harmful. People with respiratory problems may experience some temporary discomfort. If this occurs, get out of the vehicle as soon as it is safe to do so.

## Airbag System Components

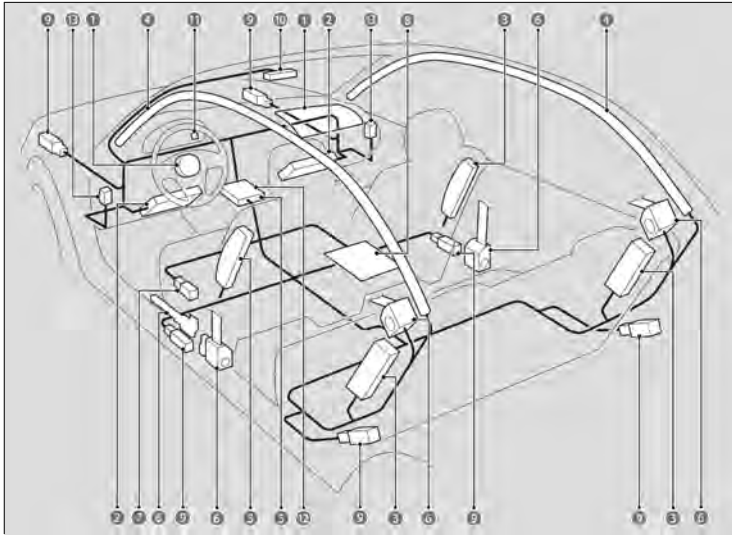

The front, driver's knee, front passenger's knee, side, and side curtain airbags are deployed according to the direction and severity of impact. Both side curtain airbags are deployed in a rollover. The airbag system includes:

- ① Two SRS (Supplemental Restraint System) front airbags. The driver's airbag is stored in the center of the steering wheel; the front passenger's airbag is stored in the dashboard. Both are marked **SRS AIRBAG**.
- ② Two knee airbags. The driver's knee airbag is stored under the steering column; the front passenger's knee airbag is stored under the glove box. Both are marked **SRS AIRBAG**.
- ③ Four side airbags. One for the driver, one for the front passenger, and two for the rear outboard seating positions. The airbags are stored in the outer edges of the seat-backs. All are marked **SIDE AIRBAG**.
- ④ Two side curtain airbags, one for each side of the vehicle. The airbags are stored in the ceiling, above the side windows. The front and rear pillars are marked **SIDE CURTAIN AIRBAG**.
- ⑤ An electronic control unit that, when the power mode is in ON, continually monitors information about the various impact sensors, seat and buckle sensors, rollover sensor, airbag activators, seat belt tensioners, and other vehicle information. During a crash event, the unit can record such information.
- ⑥ Seat belt tensioners for the front seats and outer rear seats.
- ⑦ Driver's seat position sensor. This sensor detects the driver's seat slide position to help determine the optimal deployment of the driver's airbag.
- ⑧ Weight sensors in the front passenger's seat. The sensors are used for occupant classification to activate or deactivate the front passenger's airbag.

- 9 Impact sensors that can detect a moderate-to-severe front or side impact.
- 10 An indicator on the roof console that alerts you that the passenger's airbag has been turned off.
- 11 An indicator on the instrument panel that alerts you to a possible problem with your airbag system or seat belt tensioners.
- 12 A rollover sensor that can detect if your vehicle is about to roll over and signal the control unit to deploy both side curtain airbags.
- 13 Pressure sensors that can detect a moderate-to-severe side impact.

## Important Facts About Your Airbags

Airbags can pose serious hazards. To do their job, airbags must inflate with tremendous force. So, while airbags help save lives, they can cause burns, bruises, and other minor injuries, sometimes even fatal ones if occupants are not wearing their seat belts properly and sitting correctly.

**What you should do:** Always wear your seat belt properly and sit upright and as far back from the steering wheel as possible while allowing full control of the vehicle. A front passenger should move their seat as far back from the dashboard as possible. Remember, however, that no safety system can prevent all injuries or deaths that can occur in a severe crash, even when seat belts are properly worn and the airbags deploy.

**Do not place hard or sharp objects between yourself and a front airbag.** Carrying hard or sharp objects on your lap, or driving with a pipe or other sharp object in your mouth, can result in injuries if your front airbag inflates.

**Do not attach or place objects on the front, driver's knee, and front passenger's knee airbag covers.** Objects on the covers marked **SRS AIRBAG** could interfere with the proper operation of the airbags or be propelled inside the vehicle and hurt someone if the airbags inflate.

Do not attempt to deactivate your airbags. Together, airbags and seat belts provide the best protection.

When driving, keep hands and arms out of the deployment path of the front airbag by holding each side of the steering wheel. Do not cross an arm over the airbag cover.

## Front Airbags (SRS)

**SRS** (Supplemental Restraint System) indicates that the airbags are designed to supplement seat belt not replace them. Seat belt is the occupant primary restraint system.

The front SRS airbags inflate in a moderate-to-severe frontal collision to help protect the head and chest of the driver and/or front passenger.

During a frontal crash severe enough to cause one or both front airbags to deploy, the airbags can inflate at different rates, depending on the severity of the crash, whether or not the seat belts are latched, and/or other factors. Frontal airbags are designed to supplement the seat belts to help reduce the likelihood of head and chest injuries in frontal crashes.

## Housing Locations

The front airbags are housed in the center of the steering wheel for the driver, and in the dashboard for the front passenger. Both airbags are marked **SRS AIRBAG**.

## Operation

Front airbags are designed to inflate during moderate-to-severe frontal collisions. When the vehicle decelerates suddenly, the sensors send information to the control unit which signals one or both front airbags to inflate.

A frontal collision can be either head-on or angled between two vehicles, or when a vehicle crashes into a stationary object, such as a concrete wall.

## How the Front Airbags Work



While your seat belt restrains your torso, the front airbag provides supplemental protection for your head and chest.

The front airbags deflate immediately so that they won't interfere with the driver's visibility or the ability to steer or operate other controls.

The total time for inflation and deflation is so fast that most occupants are not aware that the airbags deployed until they see them lying in front of them.

Although the driver's and front passenger's airbags normally inflate within a split second of each other, it is possible for only one airbag to deploy. This can happen if the severity of a collision is at the margin, or threshold that determines whether or not the airbags will deploy. In such cases, the seat belt will provide sufficient protection, and the supplemental protection offered by the airbag would be minimal.

### ■ When front airbags should not deploy

**Minor frontal crashes:** Front airbags were designed to supplement seat belts and help save lives, not to prevent minor scrapes, or even broken bones that might occur during a less than moderate-to-severe frontal crash.

**Side impacts:** Front airbags can provide protection when a sudden deceleration causes a driver or front passenger to move toward the front of the vehicle. Side airbags and side curtain airbags have been specifically designed to help reduce the severity of injuries that can occur during a moderate-to-severe side impact which can cause the driver or passenger to move toward the side of the vehicle.

**Rear impacts:** Head restraints and seat belts are your best protection during a rear impact. Front airbags cannot provide any significant protection and are not designed to deploy in such collisions.

Rollovers: In a rollover, your best form of protection is a seat belt or, if your vehicle is equipped with a rollover sensor, both a seat belt and a side curtain airbag. Front airbags, however, are not designed to deploy in a rollover as they would provide little, if any, protection.

### **When front airbags deploy with little or no visible damage**

Because the airbag system senses sudden deceleration, a strong impact to the vehicle framework or suspension might cause one or more of the airbags to deploy. Examples include running into a curb, the edge of a hole, or other low fixed object that causes a sudden deceleration in the vehicle chassis. Since the impact is underneath the vehicle, damage may not be readily apparent.

### **When front airbags may not deploy, even though exterior damage appears severe**

Since crushable body parts absorb crash energy during an impact, the amount of visible damage does not always indicate proper airbag operation. In fact, some collisions can result in severe damage but no airbag deployment because the airbags would not have been needed or would not have provided protection even if they had deployed.

## **Advanced Airbags**

The airbags have advanced features to help reduce the likelihood of airbag related injuries to smaller occupants.



### **1 Driver's Seat Position Sensor**

The driver's advanced airbag system includes a seat position sensor.

Based on information from this sensor and the severity of the impact, the advanced airbag system determines the optimal deployment of the driver's airbag.

The front passenger's advanced airbag system has weight sensors. The sensors are used for occupant classification to activate or deactivate the front passenger's airbag. For adult size occupants, the system will automatically activate the front passenger's airbag. If a small adult sits in the front passenger seat and the system does not recognize him/her as an adult, see

[Q Passenger Airbag Off Indicator](#) ▶ P.44

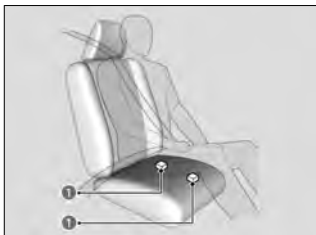

### 1 Passenger's Seat Weight Sensors

We advise against allowing a child age 12 or under to ride in the front passenger's seat. However, if you do allow a small child or infant to ride in the front passenger's seat, the system is designed to automatically deactivate the front passenger's airbag. Do not let a small child or infant ride in the front passenger's seat if the airbag does not automatically deactivate.

If there is a problem with the driver's seat position sensor or the passenger's seat weight sensors, the SRS indicator will come on, and in the event of a crash, the airbag will deploy (regardless of the driver's seating position or passenger's occupant classification) with a force corresponding to the severity of the impact.

#### Supplemental Restraint System (SRS) Indicator ▶ P.44

For the advanced front airbags to work properly, confirm that:

- The occupant is sitting in an upright position wearing the seat belt properly and the seat-back is not excessively reclined.
- The occupant is not leaning against the door or center console.
- The occupant's feet are placed on the floor in front of them.
- There are no objects hanging from the front passenger's seat.
- Only small, lightweight objects are in the seat-back pocket.
- The steering wheel and passenger's side dashboard are not obstructed by any object.
- No liquid has been spilled on or under the seat.
- There is no child seat or other object pressing against the rear of the seat or seat-back.
- There is no rear passenger pushing or pulling on the back of the front passenger's seat.
- There are no objects placed under or beside the front passenger's seat. Improperly positioned objects can interfere with the advanced airbag sensors.
- The head restraint is not contacting the roof.

#### Passenger Airbag Off Indicator ▶ P.44

- The floor mat behind the front passenger's seat is set in the correct position evenly on the floor. An improperly placed mat can interfere with the advanced airbag sensors.

#### Interior Care ▶ P.390

## Knee Airbags

The knee SRS airbags inflate in a moderate-to-severe frontal collision to help keep the driver and/or front passenger in the proper position and to help maximize the benefit provided by the vehicle's other safety features.

**SRS** (Supplemental Restraint System) indicates that the airbags are designed to supplement seat belt not replace them. Seat belt is the occupant primary restraint system.

Do not attach accessories on or near a knee airbag as they can interfere with the proper operation of the airbag, or even hurt someone if the airbag inflates.

The driver and front passenger should not store any items under the seat or behind their feet. The items can interfere with proper airbag deployment in the event of a moderate to severe frontal collision and may result in inadequate protection.

## Housing Locations

The knee airbag for the driver and the one for the front passenger are housed under the steering column and the glove box respectively.

Both are marked **SRS AIRBAG**.

## Operation



The driver's and front passenger's knee airbag deploy at the same time as the driver's and front passenger's airbag respectively.

### 1 Knee Airbag



### 1 Knee Airbag

Even if the collision is not severe enough to deploy the front airbag, the knee airbag may inflate alone.



### ■ When knee airbags deploy with little or no visible damage

Because the airbag system senses sudden deceleration, a strong impact to the vehicle framework or suspension might cause one or more of the airbags to deploy. Examples include running into a curb, the edge of a hole, or other low fixed objects that cause a sudden deceleration in the vehicle chassis. Since the impact is underneath the vehicle, damage may not be readily apparent.

### ■ When knee airbags may not deploy, even though exterior damage appears severe

Since crushable body parts absorb crash energy during an impact, the amount of visible damage does not always indicate proper airbag operation. In fact, some collisions can result in severe damage but no airbag deployment because the airbags would not have been needed or would not have provided protection even if they had deployed.

## Side Airbags

The side airbags help protect the torso and pelvis of the driver, front passenger, or an outer rear seat occupant during a moderate-to-severe side impact.

### Housing Locations

The side airbags are housed in the outside edge of the driver's and passenger's seatbacks and next to the outer rear seating positions.

Each is marked **SIDE AIRBAG**.

## Operation



When the sensors detect a moderate-to-severe side impact, the control unit signals the side airbag on the impact side to immediately inflate.

### 1 Side Airbag



### 1 Side Airbag

#### ■ When a side airbag deploys with little or no visible damage

Because the airbag system senses sudden acceleration, a strong impact to the side of the vehicle's framework can cause a side airbag to deploy. In such cases, there may be little or no damage, but the side impact sensors detected a severe enough impact to deploy the airbag.

#### ■ When a side airbag may not deploy, even though visible damage appears severe

It is possible for a side airbag not to deploy during an impact that results in apparently severe damage. This can occur when the point of impact was toward the far front or rear of the vehicle, or when the vehicle's crushable body parts absorbed most of the crash energy. In either case, the side airbag would not have been needed nor provided protection even if it had deployed.



Do not cover or replace the front and rear seat-back covers without consulting a dealer.

Improperly replacing or covering front and rear seat-back covers can prevent your side airbags from properly deploying during a side impact.

 Make sure you and your front seat and rear outboard passengers always sit upright. Leaning into the path of a side airbag can prevent the airbag from deploying properly and increases the risk of serious injury.

 Do not attach accessories on or near the side airbags. They can interfere with the proper operation of the airbags, or hurt someone if an airbag inflates.

 Side airbag deployment is controlled by a pressure sensor inside each front door. Damage or changes to the inside or outside of the doors may negatively affect side airbag deployment. Contact an authorized dealer before changing or repairing a front door.

## Side Curtain Airbags

The side curtain airbags help protect the heads of the driver and passengers in the outer seating positions during a moderate-to-severe side impact. The side curtain airbags equipped in this vehicle are also designed to help reduce the likelihood of partial and complete ejection of vehicle occupants through side windows in crashes, particularly rollover crashes.

If the SRS control unit senses that your vehicle is about to rollover, it immediately deploys both side curtain airbags and activates the seat belt tensioners for the front seats and outer rear seats.

## Housing Locations

The side curtain airbags are located in the ceiling above the side windows on both sides of the vehicle.

## Operation

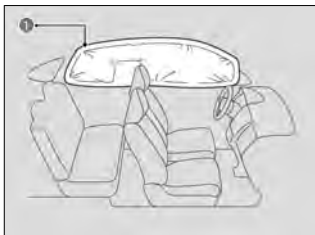

The side curtain airbag is designed to deploy in a rollover or a moderate-to-severe side impact.

### 1 Side Curtain Airbag

If the impact is on the passenger's side, the passenger's side curtain airbag deploys even if there are no occupants on that side of the vehicle.

### ■ When side curtain airbags deploy in a frontal collision

One or both side curtain airbags may also inflate in a moderate-to-severe angled frontal collision.

! Do not attach any objects to the side windows or roof pillars as they can interfere with the proper operation of the side curtain airbags.

! To get the best protection from the side curtain airbags, occupants should wear their seat belts properly and sit upright and well back in their seats.

## Airbag System Indicators

If a problem occurs in the airbag system, the SRS indicator will come on and a message appears on the driver information interface.

## Supplemental Restraint System (SRS) Indicator



- When the power mode is set to ON  
The indicator comes on for a few seconds, then goes off. This tells you the system is working properly.

If the indicator comes on at any other time, or does not come on at all, have the system checked by a dealer as soon as possible.

If you don't, your airbags and seat belt tensioners may not work properly when they are needed.

### ⚠ WARNING

Ignoring the SRS indicator can result in serious injury or death if the airbag systems or tensioners do not work properly.

Have your vehicle checked by a dealer as soon as possible if the SRS indicator alerts you to a possible problem.

## Passenger Airbag Off Indicator



### When the passenger airbag off indicator comes on

The indicator comes on to alert you that the passenger's airbag has been turned off. This occurs if the seat is empty or when the weight sensors determine that a small child or infant is on the passenger seat.

- 1 U.S.
- 2 Canada

Children age 12 or under should always ride properly restrained in a back seat.

[Q Child Safety](#) ▶ P.19

If the indicator is on, in the event of a crash the passenger's airbag will not deploy. The passenger's knee airbag will not deploy, either.

When you set the power mode to ON, the indicator comes on and goes off a few seconds later to indicate that system checks are being performed. After that, the indicator comes on or off depending on the passenger's occupant classification. To ensure the passenger is detected properly, confirm that:

- The occupant is sitting in an upright position wearing the seat belt properly and the seat-back is not excessively reclined.
- The occupant is not leaning against the door or center console.
- The occupant's feet are placed on the floor in front of them.
- There are no objects hanging from the front passenger's seat.
- Only small, lightweight objects are in the seat-back pocket.
- No liquid has been spilled on or under the seat.
- There is no child seat or other object pressing against the rear of the seat or seat-back.
- There is no rear passenger pushing or pulling on the back of the front passenger's seat.
- There are no objects placed under or beside the front passenger's seat. Improperly positioned objects can interfere with the advanced airbag sensors.
- The floor mat behind the front passenger's seat is set in the correct position evenly on the floor. An improperly placed mat can interfere with the advanced airbag sensors.
- The head restraint is not contacting the roof.

The passenger airbag off indicator may come on and go off periodically if the total weight on the seat is near the airbag cutoff threshold. For a small adult, depending on physique and posture, the system may not recognize him/her as an adult and thus deactivate the passenger's airbag.

If this occurs, please confirm that the conditions set forth in the above bullet points previously mentioned are met.

If the above conditions are met and the indicator is still on, then with the transmission in **[P]**, set the power mode to OFF and back to ON.

Have your vehicle checked by a dealer as soon as possible if:

- All of the above conditions are met, and the indicator comes on with an adult seated in the front passenger seat.
- The seat is empty and the indicator is off.
- The indicator does not come on and go off after setting the power mode to ON as described.

Do not allow an adult passenger to ride in the front seat when the indicator is on.

## Airbag Care

You do not need to, and should not, perform any maintenance on or replace any airbag system components yourself. However, you should have your vehicle inspected by a dealer in the following situations:

### When the airbags have deployed

If an airbag has inflated, the control unit and other related parts must be replaced. Similarly, once an automatic seat belt tensioner has been activated, it must be replaced.



We recommend against the use of salvaged airbag system components, including the airbag, tensioners, sensors, and control unit.

## **When the vehicle has been in a moderate-to-severe collision**

Even if the airbags did not inflate, have your dealer inspect the following: the driver's seat position sensor, weight sensors in the passenger's seat, seat belt tensioners for the front seats and outer rear seats, and each seat belt that was worn during the crash.

## **Do not remove or modify a front seat without consulting a dealer**

This would likely disable or affect the proper operation of the driver's seat position sensor or the weight sensors in the passenger's seat. If it is necessary to remove or modify a front seat to accommodate a person with disabilities, contact an Acura dealer. For U.S. vehicles, contact Acura Client Relations at 1-800-382-2238. For Canadian vehicles, contact Acura Client Services at 1-888-9-ACURA-9.

# Safety Labels

## Label Locations

These labels are in the locations shown. They warn you of potential hazards that can cause serious injury or death. Read these labels carefully.

If a label comes off or becomes hard to read (except for the U.S. dashboard label, which may be removed by the owner), contact a dealer for a replacement.

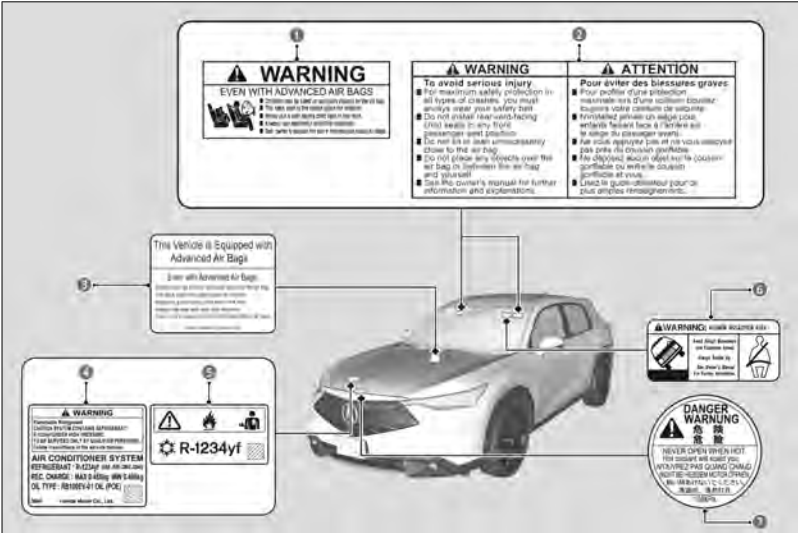

- 1 Sun Visor (U.S. models)
- 2 Sun Visor (Canadian models)
- 3 Dashboard (U.S. models only)
- 4 Air Conditioner System (U.S. models)
- 5 Air Conditioner System (Canadian models)
- 6 Sun Visor (U.S. models only)
- 7 Radiator Cap





# Key

## Details on the Key

Use the keys to start and stop the engine, and lock and unlock all the doors, tailgate, and fuel fill door.

- You can remotely start the engine using the remote engine start\*.

 Remote Engine Start\*  P.106

### Low Keyless Remote Signal Strength

The vehicle transmits radio waves to locate the keyless remote to start the engine; lock and unlock all the doors and the fuel fill door; and open the tailgate.

In the following cases, starting the engine, locking/unlocking the doors/fuel fill door, or opening the tailgate may be inhibited, or operation may be unstable:

- Strong radio waves are being transmitted by nearby equipment.
- You are carrying the keyless remote together with telecommunications equipment, laptop computers, cell phones, or wireless devices.
- A metallic object is touching or covering the keyless remote.

Battery life is about two years, but this varies depending on regularity of use.

Communication between the keyless remote and the vehicle consumes the keyless remote's battery.



Follow the advice below to prevent damage to the keys:

- Do not leave the keys in direct sunlight, or in locations with high temperature or high humidity.
- Do not drop the keys or set heavy objects on them.
- Keep the keys away from liquids, dust, and sand.
- Do not take the keys apart except to replace the battery.



Do not leave the keyless remote in the vehicle when you get out. Carry it with you.



The battery is consumed whenever the keyless remote is receiving strong radio waves. Avoid placing it near electrical appliances such as televisions and personal computers.

\*: Not available on all models

## Keyless Remote Reminder

### ■ When the power mode is in ON

If you remove the keyless remote from the vehicle and shut the door, a warning indicator will display in the instrument panel, and warning buzzers will sound from both inside and outside the vehicle.

### ■ When the power mode is in ACCESSORY

If you remove the keyless remote from the vehicle and shut the door, a warning buzzer will sound from outside the vehicle.

- Do not put the keyless remote on the dashboard or in the glove box. It may cause the warning buzzer to sound.
- Under some other conditions that can prevent the vehicle from locating the remote, the warning buzzer may also sound even if the remote is within the system's operational range.
- If the keyless remote is taken out of the vehicle after the engine has been started, you can no longer change the **ENGINE START/STOP** button mode or restart the engine. Always make sure that the remote is in your vehicle when you operate the **ENGINE START/STOP** button.
- Removing the keyless remote from the vehicle through a window does not activate the warning buzzer.

### ■ Stopping the warning buzzer

When the keyless remote is within the system's operational range, and the driver's door is closed, the warning function cancels.

- » If the alarm continues to sound, place the keyless remote in another location.

## Immobilizer System

This system prevents a key that has not been pre-registered from starting the engine. Pay attention to the following:

- Do not allow objects that emit strong radio waves near the **ENGINE START/STOP** button.
- Make sure the key is not covered by or touching a metal object.
- Do not bring a key from another vehicle's immobilizer system near the **ENGINE START/STOP** button.
- Do not put the key near magnetic items. Electronic devices, such as televisions and audio systems, emit strong magnetic fields. Note that even a key chain can become magnetic.

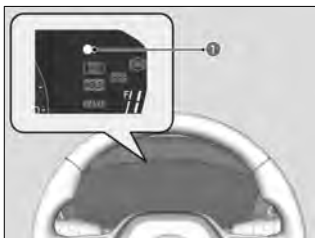

The immobilizer system indicator will blink in the instrument panel if the immobilizer system cannot recognize the key information when you have pressed **ENGINE START/STOP** button.

### 1 Immobilizer System Indicator

Do not alter the system or add other devices to it. Doing so may damage the system and make your vehicle inoperable.

#### ▼ Canadian models

Apply and hold the brake pedal before turning the vehicle on the first time after the 12-volt battery has been disconnected.

#### ▼ All models

**!** Leaving the key in the vehicle can result in theft or accidental movement of the vehicle. Always take the key with you whenever you leave the vehicle unattended.

## Security System Alarm

The security system alarm activates when the tailgate, hood, or doors are forcibly opened. The alarm does not activate if the tailgate or doors are opened with the remote transmitter or keyless access system.

Unlock the vehicle using the remote transmitter or keyless access system, or turn the power mode to ON. The system, along with the horn and flashing lights, is deactivated.

The security system alarm automatically sets when the following conditions have been met.

- The power mode is set to VEHICLE OFF.
- The hood is closed.
- All doors and the tailgate are locked from outside with the remote transmitter or keyless access system.

### ■ When the security system alarm sets

The security system alarm indicator in the instrument panel blinks and the blinking interval changes after about 15 seconds.

## To cancel the security system alarm

The security system alarm is canceled when the vehicle is unlocked using the remote transmitter or keyless access system, or when the power mode is set to ON. The security system alarm indicator goes off at the same time.

The security system alarm continues for a maximum of two minutes until the security system alarm deactivates.

Do not set the security system alarm when someone is in the vehicle or a window is open. The system can accidentally activate when:

- Unlocking the door with the lock tab.
- Opening the hood with the hood release.
- Taking the transmission out of **P**.

If the 12-volt battery goes dead after you have set the security system alarm, the security alarm may sound once the 12-volt battery is recharged or replaced.

If this occurs, deactivate the security system alarm by unlocking a door using the remote transmitter or keyless access remote.

Do not alter the system or add other devices to it. Doing so may damage the system and make your vehicle inoperable.

If you unlock a door with the built-in key while the security system is activated, the alarm will sound.

## Panic Mode



### 1 Panic Button

#### The panic button on the remote transmitter

If you press the panic button for approximately one second, the following will occur for about 30 seconds:

- The horn sounds.
- Some exterior lights flash.

#### Canceling panic mode

- Press any button on the remote transmitter.
- Set the power mode to ON.

## Built-in Key

The built-in key can be used to unlock the doors when the keyless remote battery becomes weak and the power door unlock operation is disabled.

### Removing the Built-in Key

#### ▼ Models without two-way keyless remote

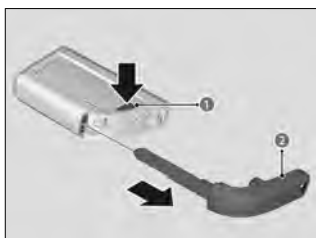

To remove the built-in key, push the release button and then pull out the key. To reinstall the built-in key, push the built-in key into the keyless remote until it clicks.

#### ▼ Models with two-way keyless remote

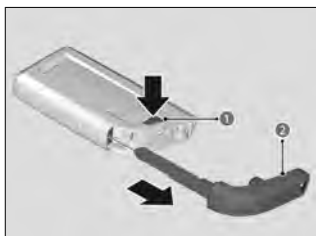

- 1 Release Button
- 2 Built-in Key

## Key Number Tag



Contains a number that you will need if you purchase a replacement key.

- If you lose your key and you cannot start the engine, contact a dealer.



Keep the key number tag separate from the key in a safe place outside of your vehicle.

# Locking/Unlocking

## Using the Remote Transmitter

### Locking the doors and tailgate

#### ▼ Models without two-way keyless remote



Press the lock button.

#### **Once:**

» Some exterior lights flash, all the doors, tailgate, and fuel fill door lock, and the security system sets.

#### **Twice (within five seconds after the first push):**

» The beeper sounds and verifies the security system is set.

#### ▼ Models with two-way keyless remote



#### 1 Lock Button

## Unlocking the doors and tailgate

### ▼ Models without two-way keyless remote



Press the unlock button.

#### Once:

» Some exterior lights flash twice, and the driver's door and fuel fill door unlocks.

#### Twice:

» The remaining doors and tailgate unlock.

### ▼ Models with two-way keyless remote



### 1 Unlock Button

If you do not open a door or the tailgate within 30 seconds of unlocking the vehicle with the remote transmitter, the doors and tailgate will automatically relock.

## Using the Keyless Access System

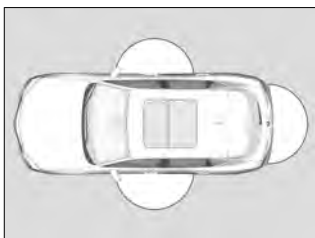

When you carry the keyless remote, you can lock/unlock the doors and fuel fill door, and open the tailgate.

You can lock/unlock the doors, fuel fill door, and tailgate within a radius of about 32 inches (80 cm) from the outside door handle or tailgate release button.

- The door may be locked/unlocked if the door handle is covered with water in heavy rain or in a car wash if the keyless remote is within range.





The light flash, beep, and door unlock mode settings can be customized.

▼ **Models with 9" Color Touchscreen**

🔍 Vehicle Settings\* ▶P.352

▼ **Models with 9" Color Touchscreen with Google built-in**

🔍 Customized Features ▶P.249

You can also unlock and open with the power tailgate.

🔍 Opening/Closing the Power Tailgate ▶P.91



Please wipe off any residue such as car shampoo, groundwater, or anti-freeze in the vicinity of the outside door handle, as there is a risk that the keyless access system may not work properly.

## Locking the doors and tailgate

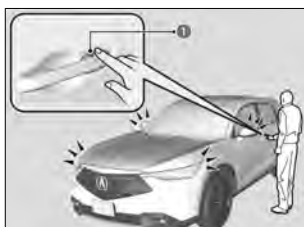

• Touch the door lock sensor on the front door or press the lock button on the tailgate.

» Some exterior lights flash; the beeper sounds; all the doors and tailgate lock; and the security system sets.

### 1 Door Lock Sensor

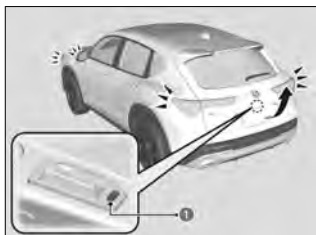

### 1 Lock Button

## Unlocking the doors and tailgate



Grab the driver's door handle:

- » The driver's door and fuel fill door unlocks.
- » Some exterior lights flash twice and the beeper sounds twice.

Grab the front passenger's door handle:

- » All doors and the tailgate unlock.
- » Some exterior lights flash twice and the beeper sounds twice.

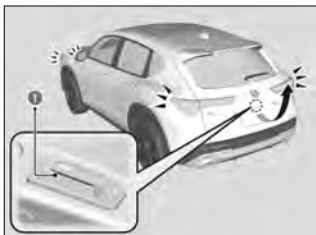

Press and hold the tailgate release button:

- » The tailgate unlocks.
- » Some exterior lights flash twice and the beeper sounds twice.

Opening/Closing the Power Tailgate P.91

### 1 Tailgate Release Button

If you do not open a door or the tailgate within 30 seconds of unlocking the vehicle with the keyless access system, the doors and tailgate will automatically relock.

You cannot lock or unlock doors using the keyless access system when the power mode is set to any mode other than VEHICLE OFF.

## Conditions under which you may not be able to lock/unlock the doors and tailgate

- If you grip a door handle wearing gloves, the door sensor may be slow to respond or may not respond by unlocking the doors.
- After locking the door, you have up to 2 seconds during which you can pull the door handle to confirm whether the door is locked. If you need to unlock the door immediately after locking it, wait at least 2 seconds before gripping the handle, otherwise the door will not unlock.
- The door might not open if you pull it immediately after gripping the door handle. Grip the handle again and confirm that the door is unlocked before pulling the handle.
- Even within the 32 inches (80 cm) radius, you may not be able to lock/unlock the doors and tailgate with the keyless remote if it is above or below the outside handle.
- The keyless remote may not operate if it is too close to the door, door glass, and tailgate.

## Locking the Doors and Tailgate (Walk Away Auto Lock®)

When you walk away from the vehicle that is power mode OFF while carrying the keyless remote, the doors, tailgate, and fuel fill door will automatically lock.

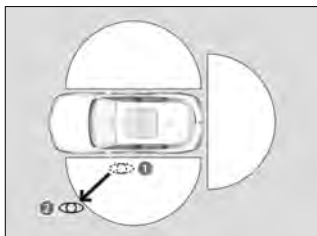

- [1] While within about 5 feet (1.5 m) radius of the vehicle.
  - » The beeper sounds; the auto lock function will be activated.
- [2] Carry the keyless remote beyond about 5 feet (1.5 m) from the vehicle and remain outside this range for 2 or more seconds.
  - » Some exterior lights flash; the beeper sounds; all doors and tailgate will then lock.

- When you stay beside the vehicle within the operation range, the doors will automatically lock approximately 30 seconds after the auto lock function activating beeper sounds.

### Auto lock function operation stop beeper

- After the auto lock function has been activated, the auto lock operation stop beeper sounds for approximately two seconds in the following cases.
  - » The keyless remote is put inside the vehicle through a window.
  - » You are located too close to the vehicle.
  - » The keyless remote is put inside the tailgate.

If the warning beeper sounds, check that you are carrying the keyless remote. Then, open/close a door and confirm the auto lock activation beeper sounds once.

- When you open a door or the tailgate after the auto lock function activating beeper sounds, the auto lock function will be canceled.
- The auto lock function is set to **OFF** as the factory default setting. The auto lock function can be set to **ON** using the driver information interface or 9" Color Touchscreen with Google built-in\*.

If you set the auto lock function to **ON**, only the remote transmitter that was used to unlock the driver's door prior to the setting change can activate auto lock.

### ▼ Models with 9" Color Touchscreen

🔍 Vehicle Settings\* ▶ P.352

### ▼ Models with 9" Color Touchscreen with Google built-in

🔍 Customized Features ▶ P.249

If you use the power tailgate walk away close function when all the doors are closed, the auto lock function will also be activated.

» When you walk away from the vehicle while the power tailgate is automatically closing, it will continue to lock automatically.

Q Power Tailgate Walk Away Close ▶P.94

### To temporarily deactivate the function:

- [1] Set the power mode to OFF.
- [2] Open the driver's door.
- [3] Using the master door lock switch, operate the lock as follows:  
Lock→Unlock→Lock→Unlock.  
» The beeper sounds, and the function is deactivated.

### To restore the function:

- Set the power mode to ON.
- Lock the vehicle without using the auto lock function
- With the keyless remote on you, move out of the auto lock function operation range.
- Open any door.

## Lock Presetting

The vehicle will automatically lock after you lock the doors in advance then close the power tailgate.

Activate lock presetting after closing any other doors besides the power tailgate.

- [1] Touch the door lock sensor on the driver's door or press the lock button on the remote transmitter.  
» Alert sounds and lock presetting is activated.
- [2] Close the power tailgate.  
» Some exterior lights flash and a beeper sounds when vehicle locks.

Make sure the doors and tailgate are locked before moving away from the vehicle.

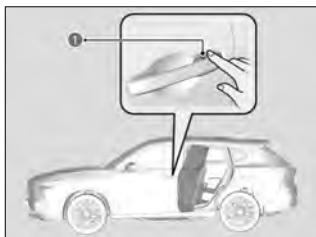

### 1 Door Lock Sensor

- Lock presetting will be reset if a door or the tailgate is opened before the vehicle has locked completely.



You can turn this function on and off.

▼ **Models with 9" Color Touchscreen**

🔍 Vehicle Settings\* ▶ P.352

▼ **Models with 9" Color Touchscreen with Google built-in**

🔍 Customized Features ▶ P.249

**⚠️ WARNING**

Opening or closing the power tailgate on someone's hands or fingers can cause serious injury.

Make sure all hands and fingers, especially children's, are clear of the power tailgate.

## Unlocking the Doors Using a Key

If the unlock button of the keyless remote does not work, use the built-in key instead. The keyhole is behind the door handle.



Pull and hold the outer handle.

Insert the built-in key into the key cylinder from below the handle and then turn it.

- » When unlocking, the driver's door and fuel fill door unlock first.
- » Turning the key a second time within a few seconds does not unlock the remaining doors and the tailgate.

If you unlock a door with the built-in key while the security system is activated, the alarm will sound.

If the lock button of the keyless remote does not work, refer to the following.

🔍 Locking a Door Without Using a Key ▶ P.60

## Locking a Door Without Using a Key

If you do not have the key on you, or if for some reason you cannot lock a door using the key, you can lock the door without it.

## Locking the front doors

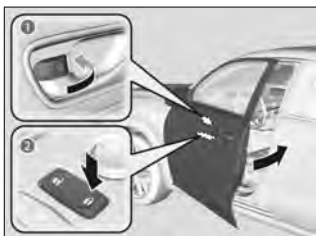

Push the lock tab forward (1) or push the master door lock switch in the lock direction (2), and close the door.

» When you lock the driver's door, all the other doors and tailgate lock at the same time.

## Locking the rear doors

Push the lock tab forward and close the door.

## Lockout protection function

If the vehicle cannot detect the keyless remote, lockout protection activates:

- » A beeper sounds, some exterior lights flash, the doors unlock, and a message appears on the driver information interface.
- » This allows you to open a door in case the keyless remote is still inside the vehicle.

If you do not open a door, all doors relock after 15 seconds.

To avoid non-detection, make sure to keep the keyless remote away from cell phones and other devices that may cause signal interference.



You can change the lockout protection operation setting.

### ▼ Models with 9" Color Touchscreen

🔍 Vehicle Settings\* ▶ P.352

### ▼ Models with 9" Color Touchscreen with Google built-in

🔍 Customized Features ▶ P.249

## Checking Door Lock Status\*

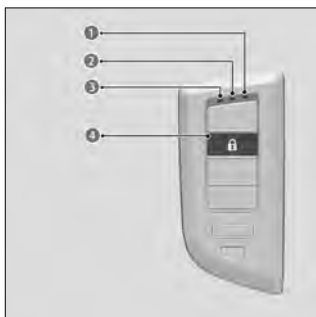

- 1 Red
- 2 Green
- 3 Amber
- 4 Lock Button

You can remotely check if your vehicle's doors are all locked or any are unlocked using the keyless remote from extended distances.

Press the lock button, the Amber (LEFT) LED blinks once. After three seconds, one of the following feedback will come:

- Green (center) comes on: Acknowledges that the doors are locked.
- Red (right) comes on: Acknowledges that doors are not locked, or any door is not completely closed.
- Red (right) blinks three times: The remote does not receive the door lock status from the vehicle.

Operate the remote in an open space. If there are buildings or other obstacles between your vehicle and the remote, the remote may not work even within the operable range. However, the range required for unlocking the tailgate and all the doors as well as activating the panic function is the same as that required for operating the standard keyless remote.

When checking the door lock status, you can also start or stop the engine.

 Remote Engine Start\* ▶ P.106

\*: Not available on all models

## Locking/Unlocking the Doors from the Inside

### Using the Lock Tab



**Locking a door:** Push the lock tab forward.

**Unlocking a door:** Pull the lock tab rearward.

» When you lock the door using the lock tab on the driver's door, all of the other doors, tailgate, and fuel fill door lock at the same time.

1 To Lock

2 To Unlock

### Unlocking Using the Front Door Inner Handle

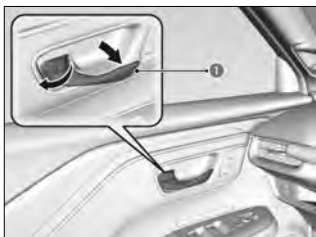

Pull the front door inner handle.

» The door unlocks and opens in one motion.

1 Inner Handle

Unlocking and opening the driver's door from the inner handle unlocks all the other doors.

To avoid all the doors unlocking, use the lock tab on the driver's door to unlock, then lock again before opening the door.

» This setting works for one time only. If you do not want all the doors to be unlocked all the time, customize the **Auto door unlock** setting to **OFF** using the driver information interface or 9" Color Touchscreen with Google built-in\*.

#### ▼ Models with 9" Color Touchscreen

🔍 Vehicle Settings\* ▶ P.352

#### ▼ Models with 9" Color Touchscreen with Google built-in

🔍 Customized Features ▶ P.249

\*: Not available on all models



**!** The front door inner handles are designed to allow front seat occupants to open the door in one motion. However, this feature requires that front seat occupants never pull a front door inner handle while the vehicle is in motion.

**!** Children should always ride in a rear seat where childproof door locks are provided.

**Q** Childproof Door Locks ▶ P.65

## Using the Master Door Lock Switch

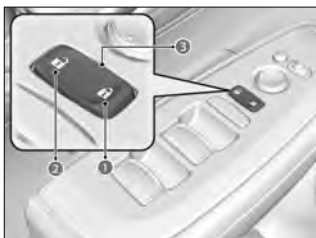

Press the master door lock switch in as shown to lock or unlock all the doors, tailgate, and fuel fill door.

» When you lock/unlock either front door using the master door lock switch, all the other doors, tailgate, and fuel fill door lock/unlock at the same time.

- 1 To Lock
- 2 To Unlock
- 3 Master Door Lock Switch

## Auto Door Locking/Unlocking

Your vehicle locks or unlocks all doors automatically when a certain condition is met.

### Drive Lock Mode

All doors lock when the vehicle's speed reaches about 10 mph (15 km/h).

### Driver's Door Open Mode

All doors and the tailgate unlock when the driver's door is opened.



You can turn off or change to another auto door locking/unlocking setting.

▼ **Models with 9" Color Touchscreen**

🔍 Vehicle Settings\* ▶ P.352

▼ **Models with 9" Color Touchscreen with Google built-in**

🔍 Customized Features ▶ P.249

## Childproof Door Locks

The childproof door locks prevent the rear doors from being opened from the inside regardless of the position of the lock tab.

### Setting the Childproof Door Locks



Slide the lever in the rear door to the lock position and close the door.

- 1 Lock
- 2 Unlock

- Open the door using the outside door handle.
- To open the door from the inside when the childproof door lock is on, put the lock tab in the unlock position, lower the rear window, put your hand out of the window, and pull the outside door handle.

## What to Do If

### The rear door cannot be opened from inside the vehicle. Why?

Check if the childproof lock is in the lock position. If so, open the rear door with the outside door handle.

To cancel this function, slide the lever up to the unlock position.

🔍 Childproof Door Locks ▶ P.65

### Why does the beeper sound when I open the driver's door?

The beeper sounds when:

- The power mode is in ACCESSORY.

- The exterior lights are left on.
- The Auto Idle Stop is in operation.

## **■ Why does a beeper sound when I walk away from the vehicle after I close the door?**

The buzzer sounds if you move outside the walk away auto door lock operating range before the door completely closes.

 Locking the Doors and Tailgate (Walk Away Auto Lock®) ▶ P.58

## **■ Why is the remote transmitter not working properly ?**

If the distance at which the remote transmitter works varies, the battery is probably low.

If the LED does not come on when you press a button, the battery is dead.

 Replacing the Remote Battery ▶ P.397

# Steering Wheel

## Adjusting the Steering Wheel

The steering wheel height and distance from your body can be adjusted so that you can comfortably grip the steering wheel in an appropriate driving posture.



- 1 To adjust
- 2 To lock
- 3 Lever

- [1] While the vehicle is stopped, push the steering wheel adjustment lever down.
  - » The steering wheel adjustment lever is under the steering column.
- [2] Move the steering wheel up or down, and in or out.
  - » Make sure you can see the instrument panel gauges and indicators.
- [3] Pull the steering wheel adjustment lever up to lock the steering wheel in position.
  - » After adjusting the position, make sure you have securely locked the steering wheel in place by trying to move it up, down, in, and out.

### **⚠ WARNING**

Adjusting the steering wheel position while driving may cause you to lose control of the vehicle and be seriously injured in a crash.  
Adjust the steering wheel only when the vehicle is stopped.

# Seats

## Adjusting the Seat

### Maintain a Proper Sitting Position

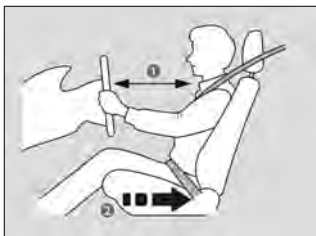

Adjust the driver's seat as far back as possible while allowing you to maintain full control of the vehicle. You should be able to sit upright, well back in the seat and be able to adequately press the pedals without leaning forward, and grip the steering wheel comfortably. The passenger's seat should be adjusted in a similar manner so that it is as far back from the front airbag in the dashboard as possible.

- 1 Allow sufficient space.
- 2 Move back.

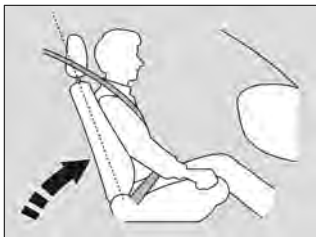

Adjust the driver's seat-back to a comfortable, upright position, leaving ample space between your chest and the airbag cover in the center of the steering wheel.

The front seat passenger should also adjust their seat-back to a comfortable, upright position.

Reclining a seat-back so that the shoulder part of the belt no longer rests against the occupant's chest reduces the protective capability of the belt. It also increases the chance of sliding under the belt in a crash and being seriously injured. The farther a seat-back is reclined, the greater the risk of injury.

### **⚠ WARNING**

Sitting too close to a front airbag can result in serious injury or death if the front airbags inflate.

Always sit as far back from the front airbags as possible while maintaining control of the vehicle.

The National Highway Traffic Safety Administration and Transport Canada recommend that drivers allow at least 10 inches (25 cm) between the center of the steering wheel and the chest.

**⚠ WARNING**

Reclining the seat-back too far can result in serious injury or death in a crash.

Adjust the seat-back to an upright position, and sit well back in the seat.

**⚠ WARNING**

Sitting improperly or out of position can result in serious injury or death in a crash.

Always sit upright, well back in the seat, with your feet on the floor.

## Head Restraints

Your vehicle is equipped with head restraints in all seating positions.

In order for the head restraint system to work properly:

- Do not hang any items on the head restraints or from the restraint legs.
- Do not place any objects between an occupant and the seat-back.
- Install each restraint in its proper location.

### Adjusting the Front Head Restraint Positions

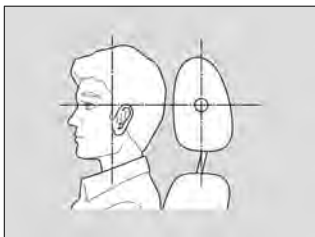

Head restraints are most effective for protection against whiplash and other rear impact crash injuries when the center of the back of the occupant's head rests against the center of the restraint. The tops of the occupant's ears should be level with the center height of the restraint.

Position head in the center of the head restraint.

**⚠ WARNING**

Improperly positioning head restraints reduces their effectiveness and increases the likelihood of serious injury in a crash.

Make sure head restraints are in place and positioned properly before driving.

## ⚠ WARNING

Failure to reinstall or correctly reinstall the head restraints can result in severe injury during a crash.  
Always replace the head restraints before driving.

## Adjusting the Front Seat Positions

Always make seat adjustments before driving.

### ■ Adjusting the front power seat(s\*)

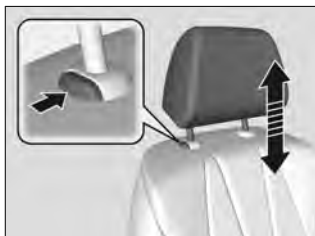

#### **To raise the head restraint:**

Pull it upward.

#### **To lower the head restraint:**

Push it down while pressing the release button.

#### **To remove the head restraint:**

Pull the restraint up as far as it will go. Then, push the release button and pull the restraint up and out.

#### **To reinstall a head restraint:**

Insert the legs back in place, then adjust the head restraint to an appropriate height while pressing the release button.

» Pull up on the restraint to make sure it is locked in position.

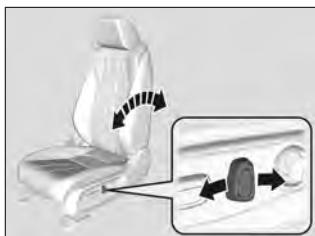

#### **Seat-back Angle Adjustment**

Push forward or pull backward the switch to change the angle.

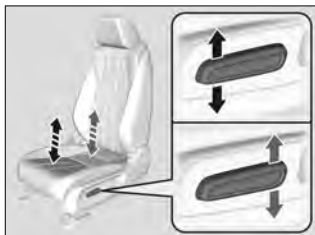

#### **Height Adjustment (Driver's seat only)**

Pull up or push down the switch to raise or lower the seat.

\*: Not available on all models



### Horizontal Position Adjustment

Slide the switch to move the seat.

## Lumbar support adjustment\*

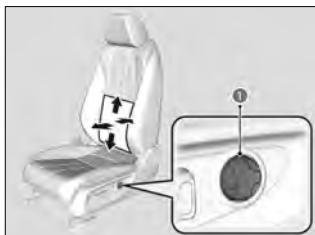

### Lumbar Support Adjustment Switch

**Press the top:** To move the lumbar support up.

**Press the bottom:** To move the lumbar support down.

**Press the front:** To increase the entire lumbar support.

**Press the rear:** To decrease the entire lumbar support.

### 1 Lumbar Support Adjustment Switch

## Adjusting the front manual seat\*

Once a seat is adjusted correctly, rock it back and forth to make sure it is locked in position.



### To raise the head restraint:

Pull it upward.

### To lower the head restraint:

Push it down while pressing the release button.

### To remove the head restraint:

Pull the restraint up as far as it will go. Then, push the release button and pull the restraint up and out.

### To reinstall a head restraint:

Insert the legs back in place, then adjust the head restraint to an appropriate height while pressing the release button.

» Pull up on the restraint to make sure it is locked in position.

\*: Not available on all models



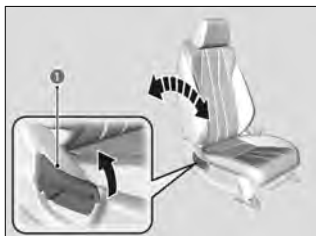

### Seat-back Angle Adjustment

Pull up the lever to change the angle.

#### 1 Lever



### Horizontal Position Adjustment

Pull up on the bar to move the seat, then release the bar.

#### 1 Bar

## Using the Front Seat Armrest



The console lid can be used as an armrest.

## Adjusting the Rear Outer and Center Seat Positions

Always make seat adjustments before driving.



A passenger sitting in the rear seat should adjust the height of their head restraint to an appropriate position before the vehicle begins moving.

**To raise the head restraint:**

Pull it upward.

**To lower the head restraint:**

Push it down while pressing the release button.

**To remove the head restraint:**

Pull the restraint up as far as it will go. Then, push the release button and pull the restraint up and out.

**To reinstall a head restraint:**

Insert the legs back in place, then adjust the head restraint to an appropriate height while pressing the release button.

» Pull up on the restraint to make sure it is locked in position.

**Using the Rear Seat Armrest**



Pull down the armrest in the center seat-back.

**Folding Down the Rear Seats**

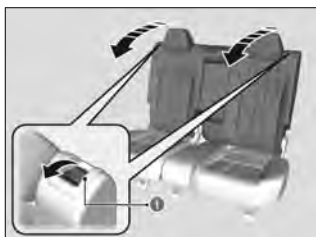

**1 Release Lever**

The rear seats can be folded down separately to allow for additional storage space.

- [1] Store the center seat belt first. Insert the latch plate into the slot on the side of the anchorage buckle.
  - [2] Retract the seat belt into the holder on the ceiling.
- 🔍 Seat Belt with Detachable Anchor ▶ P.82
- [3] Lower the head restraint to its lowest position. Put the armrest back into the seat-back.
  - [4] Pull the release lever and fold down the seat.



Make sure all items in the cargo area or items extending to the rear seats are properly secured. Loose items can fly forward if you have to brake hard.

Remove any items from the rear seat cushion and floor before you fold down the rear seat.

To lock a seat-back upright, push it backwards until it locks.

Make sure the seat-back, head restraints and seat cushion are securely latched back into place before driving. Also, make sure all rear shoulder belts are positioned in front of the seat-back.

Make sure that the folded seat-back does not press against the front passenger seat, as this can cause the weight sensors in the front passenger seat to work improperly.

 Passenger Airbag Off Indicator ▶ P.44

## Driving Position Memory System\*

You can store two driver's seat positions (except for power lumbar) with the driving position memory system.

When you unlock and open the driver's door with a keyless remote or keyless access system, the seat automatically adjusts to one of the two preset positions.

The driver's seat moves rearward depending on the set seating position once you:

- Stop the vehicle.
- Put the transmission in **P**.
- Turn the engine off.
- Open the driver's door.

Once the power mode is in the ACCESSORY position, the driver's seat moves forward to the DRIVER 1 or 2 preset position.

### System Operation

The system will not operate if:

- The transmission is out of the **P** position.
- Either memory button is pressed while the seat is in motion.
- The seat position is adjusted while in operation.
- Either of the memorized positions is set fully to the rear.

The system may not recognize a key if:

- The key is in close proximity to a cell phone or other wireless device.
- Both keys are in the vehicle at the same time.
- The Driving Position Memory System is disabled in customized features.
- You open driver's door without fully grabbing the door handle.

\*: Not available on all models

## Storing a Position in Memory



- [1] Set the power mode to ON. Adjust the driver's seat to the desired position.
- [2] Press the **SET** button.
  - » The **SET** button indicator light will come on.
- [3] Press the memory button **1** or **2** within five seconds of pressing the **SET** button.
  - » You will hear the beeper, and the **SET** button indicator light goes off.

- 1** Memory Button 1
- 2** Memory Button 2
- 3** SET Button

After you press the **SET** button, the storing operation will be canceled when:

- You do not press the memory button within five seconds.
- You readjust the seat position before the double-beep.
- You set the power mode to any position except ON.
- The position of the lumbar support is not stored.

## Recalling the Stored Position



- [1] Put the transmission into **P**.
- [2] Apply the parking brake.
- [3] Press a memory button (**1** or **2**).
  - » The seat will automatically move to the memorized position.

- 1** Memory Button 1
- 2** Memory Button 2

The seat will stop moving if you:

- Press the **SET** button, or a memory button (**1** or **2**).
- Adjust the seat position.
- Put the transmission to a position other than **P**.



You can disable the automatic seat adjustment function.

[Customized Features](#) ▶ P.249



The driver's seat easy exit feature can be turned On or Off.

[Customized Features](#) ▶ P.249

## Rear Seat Reminder

This feature alerts you to the possible presence of passengers or items in the rear seats before you exit the vehicle. It activates when the vehicle is set to VEHICLE OFF if the rear doors were opened shortly before or after the vehicle was set to ON.



A reminder appears on the driver information interface and an alert will sound when the power mode is set to VEHICLE OFF.

- When the power mode is set to VEHICLE OFF, the reminder comes on briefly, then the function is deactivated.
- The reminder will not work if the power mode has not been set to ON within 10 minutes of operating the rear doors.
- The system does not detect passengers in the rear seats. Instead, it can detect when a rear door is opened and closed, indicating that there may be something in the rear seats.



You can turn off the notification setting

▼ **Models with 9" Color Touchscreen**

🔍 Vehicle Settings\* ▶ P.352

▼ **Models with 9" Color Touchscreen with Google built-in**

🔍 Customized Features ▶ P.249

\*: Not available on all models

# Seat Belts

## About Your Seat Belts

Seat belts are the single most effective safety device because they keep you connected to the vehicle so that you can take advantage of many built-in safety features. They also help keep you from being thrown against the inside of the vehicle, against any passengers, or out of the vehicle. When worn properly, seat belts also keep your body properly positioned in a crash so that you can take full advantage of the additional protection provided by the airbags.

### Lap/shoulder seat belts

All five seating positions are equipped with lap/shoulder seat belts with emergency locking retractors. In normal driving, the retractor lets you move freely while keeping some tension on the belt. During a collision or sudden stop, the retractor locks to restrain your body.

The front passenger's and rear seat belts also have a lockable retractor for use with child seats.

 Child Safety ▶ P.19

In addition, seat belts help protect you in almost every type of crash, including:

- frontal impacts
- side impacts
- rear impacts
- rollovers

Seat belts cannot completely protect you in every crash. But in most cases, seat belts can reduce your risk of serious injury.

Most states and all Canadian provinces and territories require you to wear seat belts. If a passenger moves around and extends the seat belt, the lockable retractor may activate. If this happens, release the retractor by unfastening the seat belt and allow the belt to retract completely. Then refasten the belt.

### WARNING

Not wearing a seat belt properly increases the chance of serious injury or death in a crash, even though your vehicle has airbags.

Be sure you and your passengers always wear seat belts and wear them properly.



Follow these guidelines for proper use:

- All occupants should sit upright, well back in the seat, and remain in that position for the duration of the trip. Slouching and leaning reduce the effectiveness of the belt and can increase the chance of serious injury in a crash.
- Never place the shoulder part of a lap/shoulder seat belt under your arm or behind your back. This could cause very serious injuries in a crash.
- Two people should never use the same seat belt. If they do, they could be very seriously injured in a crash.
- Do not put any accessories on the seat belts. Devices intended to improve comfort or reposition the shoulder part of a seat belt can reduce the protective capability and increase the chance of serious injury in a crash.



If you extend the seat belt too quickly, it will lock in place. If this happens, slightly retract the seat belt, then extend it slowly.

## Seat Belt Reminder

The beeper will periodically sound and the indicator will blink.

The indicator will also come on if a front passenger does not fasten their seat belt within six seconds after the power mode is set to ON.

When no one is sitting in the front passenger's seat, the indicator will not come on and the beeper will not sound.

The indicator also may not come on and the beeper may not sound when the occupant is not heavy enough to trigger the weight sensor. Such occupants (e.g., infants and smaller children) should be moved to the rear seat as a deploying front airbag likely will injure or kill them.

### Protecting Child Passengers ► P.19

The driver information interface uses colors to aid the driver in checking the status of the passengers.

For the front seating positions:

- Green indicates the seat belt is fastened.
- An unfastened gray graphic indicates the seat belt is not fastened and an occupant has not been detected.
- An unfastened red graphic indicates the seat belt is unfastened and an occupant has been detected.

## Front seats



The seat belt system includes an indicator on the instrument panel to remind the driver or a front passenger or both to fasten a seat belt. If you set the power mode to ON and a seat belt is not fastened, a beeper will sound and the indicator will blink. After a few seconds, the beeper will stop and the indicator will come on and remain illuminated until the seat belt is fastened.

- 1 Fastened
- 2 Unfastened

## Rear seats



Your vehicle monitors rear seat belt use. The Rear seat belt reminder notifies you with the driver information interface, the beeper sounds, or both if any of the rear seat belts are not used. The rear seat belt reminder operates under any of the following circumstances:

- Any of the rear passengers have not fastened their seat belt since the power mode was set to ON.
- Any of the rear seat belts have come off while driving.

- 1 Fastened
- 2 Unfastened

The system will not detect a passenger in the rear seats who has not fastened the seat belt.

The driver should check the status of the rear passengers' seat belts at the start of each trip and each time a passenger is seated in the rear seats, using the driver information interface as an aid.

An alert will sound if a passenger in the rear seats unfastens the seat belt while the vehicle is in motion or if motion resumes while the graphic is red.

The system does not monitor harnesses that are part of a child seat, nor the anchors of the LATCH system. While the system can inform you that a seat belt is fastened, it cannot determine whether a child seat is properly installed or used.

Protecting Child Passengers ► P.19

## Automatic Seat Belt Tensioners

The front seats and the outer rear seats are equipped with automatic seat belt tensioners to enhance safety.



The tensioners automatically tighten the front seat belts and the outer rear seat belts during a moderate-to-severe frontal or side collision, sometimes even if the collision is not severe enough to inflate the front airbags or the knee airbags.

The seat belt tensioners can only operate once. If a tensioner is activated, the SRS indicator will come on. Have a dealer replace the tensioner and thoroughly inspect the seat belt system as it may not offer protection in a subsequent crash.

## Fastening a Seat Belt

After adjusting a front seat to the proper position, and while sitting upright and well back in the seat:

Q Adjusting the Seat ▶ P.68



[1] Pull the seat belt out slowly.



[2] Insert the latch plate (1) into the buckle (2), then tug on the belt to make sure the buckle is secure.

» Make sure that the belt is not twisted or caught on anything.



[3] Position the lap part of the belt as low as possible across your hips (see illustration), then pull up on the shoulder part of the belt so the lap part fits snugly. This lets your strong pelvic bones take the force of a crash and reduces the chance of internal injuries.

[4] If necessary, pull up on the belt again to remove any slack, then check that the belt rests across the center of your chest and over your shoulder. This spreads the forces of a crash over the strongest bones in your upper body.

To release the belt, push the red **PRESS** button and then guide the belt by hand until it has retracted completely.

When exiting the vehicle, be sure the belt is properly stowed so that it will not get caught in the closing door.

- ❗ If the seat belt appears to be locked in a fully retracted position, firmly pull out on the shoulder belt once, then push it back in. Then, smoothly pull it out of the retractor and fasten. If you are unable to release the seat belt from a fully retracted position, do not allow anyone to sit in the seat, and take your vehicle to a dealer for repair.

🔍 About Your Seat Belts ▶P.77

- ❗ No one should sit in a seat with an inoperative seat belt or one that does not appear to be working correctly. Using a seat belt that is not working properly may not protect the occupant in a crash. Have a dealer check the belt as soon as possible.

### ⚠️ WARNING

Improperly positioning the seat belts can cause serious injury or death in a crash.

Make sure all seat belts are properly positioned before driving.

- ❗ Never insert any foreign objects into the buckle or retractor mechanism.

## Advice for Pregnant Women



### Consider alternative:

If you are pregnant, the best way to protect yourself and your unborn child when driving or riding in a vehicle is to always wear a seat belt. When positioning the seat belt, wear the shoulder belt section across the chest, avoiding the abdomen, and keep the lap belt portion as low as possible across the hips. (See illustration.)

Each time you have a checkup, ask your doctor if it is okay for you to drive.

**!** To reduce the risk of injuries to both you and your unborn child that can be caused by an inflating front airbag:

- When driving, sit upright and adjust the seat as far back as possible while allowing full control of the vehicle.
- When sitting in the front passenger's seat, adjust the seat as far back as possible.

## Adjusting the Shoulder Anchor

The front seats have adjustable shoulder anchors to accommodate taller and shorter occupants.



- [1] Move the anchor up and down while holding the release button (1).
- [2] Position the anchor so that the belt rests across the center of your chest and over your shoulder.

- The shoulder anchor height can be adjusted to three levels. If the belt contacts your neck, lower the height one level at a time.

After an adjustment, make sure that the shoulder anchor position is secure.

## Seat Belt with Detachable Anchor

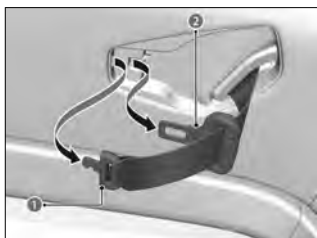

- [1] Pull out the seat belt's small latch plate (1) and the latch plate (2) from each holding slot in the ceiling.



- [2] Line up the triangle marks (1) on the small latch plate (2) and anchor buckle (3).  
 » Make sure the seat belt is not twisted. Attach the belt to the anchor buckle.

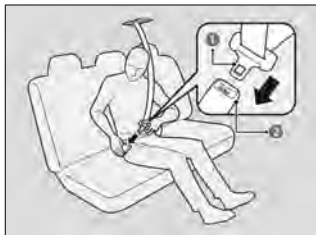

- [3] Insert the latch plate (1) into the buckle (2). Properly fasten the seat belt the same way you fasten the lap/shoulder seat belt.



- To unlatch the detachable anchor (1), insert the latch plate (2) into the slot on the side of the anchor buckle (3).

### ⚠ WARNING

Using the seat belt with the detachable anchor unfastened increases the chance of serious injury or death in a crash. Before using the seat belt, make sure the detachable anchor is correctly latched.

## Seat Belt Inspection

Regularly check the condition of your seat belts as follows:

- Pull each belt out fully, and look for frays, cuts, burns, and wear.
- Check that the latch plates and buckles work smoothly and the belts retract easily.
  - » If a belt does not retract easily, cleaning the belt may correct the problem. Only use a mild soap and warm water. Do not use bleach or cleaning solvents. Make sure the belt is completely dry before allowing it to retract.

Any belt that is not in good condition or working properly will not provide proper protection and should be replaced as soon as possible.

A belt that has been worn during a crash may not provide the same level of protection in a subsequent crash. Have your seat belts inspected by a dealer after any collision.

 **WARNING**

Not checking or maintaining seat belts can result in serious injury or death if the seat belts do not work properly when needed.

Check your seat belts regularly and have any problem corrected as soon as possible.

# Mirrors

## Interior Rearview Mirror



Adjust the angle of the rearview mirror when you are sitting in the correct driving position.

Adjust the mirrors before you start driving.

Keep the inside and outside mirrors clean and adjusted for best visibility.

## Automatic Dimming Rearview Mirror



When you are driving after dark, the automatic dimming rearview mirror reduces the glare from headlights behind you. Press the  button to turn this function on and off. When activated, the  indicator comes on.

» The auto dimming function cancels when the transmission is in **R**.

1  Button

## Power Door Mirrors

You can adjust the door mirrors when the power mode is in ON.



1 **L/R selector switch:**

Select the left or right mirror. After adjusting the mirror, return the switch to the center position.

2 **Mirror position adjustment switch:**

Press the switch left, right, up, or down to move the mirror.

3 **Folding button\***

Press the folding button\* to fold in and out the door mirrors.

\*: Not available on all models

## Reverse Tilt Door Mirror



If activated, the passenger side door mirror automatically tilts downward when you put the transmission into **R**: This improves close-in visibility on the passenger side of the vehicle when backing up. The mirror automatically returns to its original position when you take the transmission out of **R**.

### 1 Selector Switch

To activate this feature, set the power mode to ON and slide the selector switch to the passenger's side.

## Automatic Folding Door Mirror Function\*

When the door is locked or unlocked via the remote transmitter or keyless access system, the door mirrors will automatically fold in or return to their previous position, even when the power mode is set to OFF.

### Folding in the door mirrors

- Press the lock button on the keyless remote, touch the door lock sensor on the front door, or press the lock button on the tailgate.
  - » The mirrors start folding in automatically.

### Folding out the door mirrors

- Unlock the driver's door using the keyless remote or keyless access system.
  - » The mirrors start folding out automatically.
- If you use the fold button to fold the door mirrors, the auto folding door mirror function will not work.

Door mirrors will not fold automatically when locking from inside the vehicle using lock tab or master door lock switch.



You can turn the automatic folding door mirror function on and off.

 Customized Features  P.249

\*: Not available on all models

# Windows

## Opening/Closing the Power Windows

The power windows can be opened and closed when the power mode is in ON, using the switches on the doors.

The driver's side switches can be used to open and close all the windows. The power window lock button on the driver's side must be switched off to open and close the windows from anywhere other than the driver's seat.

When the power window lock button is pushed in, the indicator comes on and you can only operate the driver's window. Turn the power window lock button on if a child is in the vehicle.



- ① Driver's Window Switch
- ② Front Passenger's Switch
- ③ Rear Passenger's Switch

### Manual operation

**To open:** Push the switch down lightly, and hold it until the desired position is reached.

**To close:** Pull the switch up lightly, and hold it until the desired position is reached.

### Automatic operation

**To open:** Push the switch down firmly.

**To close:** Pull the switch up firmly.

The window opens or closes completely. To stop the window at any time, push or pull the switch briefly.

## ⚠ WARNING

Closing a power window on someone's hands or fingers can cause serious injury.

Make sure your passengers are away from the windows before closing them.

- The power windows can be operated for up to 10 minutes after you set the power mode to VEHICLE OFF.  
Opening either front door cancels this function.



### Auto Reverse

» If a power window senses resistance when closing automatically, it will stop closing and reverse direction.

If the auto reverse function is activated due to a malfunction or impact caused by the road surface or driving conditions and the window cannot be closed automatically, you can close it by continuously pulling up the switch briefly. While driving with any of the windows open, you may hear a booming, throbbing, or helicopter-type noise or pressure. This is called wind buffeting. This is a normal occurrence that can be minimized.

If you hear a wind buffeting noise with any of the windows slightly, open the moonroof\*, or open the panoramic roof\* to the comfort position.

- The driver's window auto reverse function is disabled when you continuously pull up the switch.
- The auto reverse function stops sensing when the window is almost closed to ensure that it fully closes.

### Power Window Lock Button



When the power window lock button is set to ON (indicator on), any window other than that on the driver's side will not operate.

- 1 Power Window Lock Button
- 2 Indicator

**!** Turn the power window lock button on if a child is in the vehicle.

### Opening the Windows with the Remote

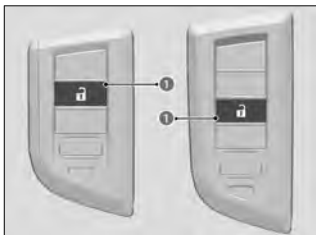

#### To open

Press the unlock button (1), and then within 10 seconds, press it again and hold it.

\*: Not available on all models

If you open the windows with the remote transmitter, the moonroof\*/panoramic roof will open automatically along with them.

\*: Not available on all models

# Tailgate

## Precautions for Opening/Closing the Tailgate

Always make sure individuals and objects are clear of the tailgate before opening or closing it.

The power tailgate may not open or close under the following conditions:

- You start the engine while the tailgate is automatically opening or closing.
- The vehicle is parked on a steep hill.
- The vehicle is swayed in a strong wind.
- The tailgate or the roof is covered with snow or ice.

When operating the power tailgate, make sure there is enough space around your vehicle. People near the tailgate may be seriously hurt if the tailgate hits or closes on their heads. Be especially cautious if children are around.

Keep the tailgate closed while driving to:

- » Avoid possible damage.
- » Prevent exhaust gas from leaking into the vehicle.

 Carbon Monoxide Gas ▶ P.31

- Do not leave the keyless remote in the vehicle when you get out. Carry it with you.
- Even if you are not carrying the remote, you can unlock the tailgate while someone else with the remote is within range.
- Do not leave the keyless remote inside the cargo area and close the tailgate. The beeper sounds and the tailgate cannot be closed.

### WARNING

Anyone caught in the path of a tailgate that is being opened or closed can be seriously injured.

Make sure that all people are clear of the tailgate before opening or closing it.

The power tailgate can be opened/closed when the transmission is in **P**.

- If the power tailgate meets resistance while opening or closing, the auto reverse feature reverses the direction. The beeper sounds three times.
- The beeper sounds when you start driving while the power tailgate is still open, or closing.

### WARNING

Opening or closing a power tailgate while any part of a passenger is in the tailgate's operating path can cause serious injury.

Make sure all passengers or objects are clear of the tailgate operating range before opening or closing the tailgate.

❗ Be careful not to hit your head on the tailgate or to put your hands between the tailgate and the cargo area when closing the tailgate.

❗ When you are storing or picking up luggage from the cargo area or by using a forward and back kicking motion under the center of the rear bumper for hands free access\*, while the engine is idling, do not stand in front of the exhaust pipe. You may get burned.

❗ Do not allow any passenger in the cargo space. They may get hurt during hard braking, a sudden acceleration, or a crash.

❗ Do not push or pull on the power tailgate when it is being automatically opened or closed.  
Forcibly opening or closing the power tailgate while in operation can deform the tailgate frame.

❗ Installing aftermarket components other than Acura Genuine accessories on the power tailgate may prevent it from fully opening or closing.

## Opening/Closing the Power Tailgate

### Using the Tailgate Outer Handle

#### ■ Opening the tailgate

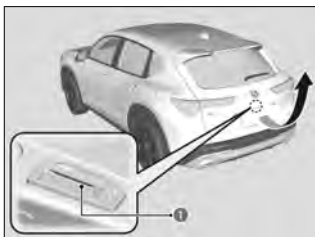

If you press the tailgate release button for no longer than one second, the tailgate opens automatically.

» The beeper sounds.

#### ❶ Tailgate Release Button

\*: Not available on all models

- If you are carrying the keyless remote, you do not have to unlock the tailgate before opening it.
- If you want to open the tailgate manually, press the button for more than one second and wait until you hear beeps.
- If you press the tailgate release button again while the power tailgate is moving, it will stop. Press the tailgate release button, and the power tailgate will reverse direction.

## ■ Closing the tailgate



Press the button (1) on the tailgate to close the power tailgate.

» The beeper sounds.

### 1 Tailgate Inner Button

- Do not touch the sensors located on both sides of the tailgate. The power tailgate does not close if you touch either sensor when you are trying to close the tailgate.
- Be careful not to scratch the sensors with a sharp object. If scratched, they can be damaged, and the power tailgate closing feature malfunctions.
- If you press the button again while the power tailgate is moving, it will stop. Press and release the button again, and the power tailgate will reverse direction.



You can change the power tailgate operation setting on and off.

#### ▼ Models with 9" Color Touchscreen

🔍 Vehicle Settings\* ▶ P.352

#### ▼ Models with 9" Color Touchscreen with Google built-in

🔍 Customized Features ▶ P.249

## Using the Remote Transmitter



Press the power tailgate button for more than one second to operate when the power mode is in VEHICLE OFF.

» Some exterior lights flash and the beeper sounds.

### 1 Power Tailgate Button

- If you press the button again while the power tailgate is moving, it will stop. Press the button for more than one second, and the power tailgate will reverse direction.

### Customizing when to open the tailgate



**Anytime** The power tailgate unlocks and opens at the same time. This is the default setting.

▼ **Models with 9" Color Touchscreen**

🔍 Vehicle Settings\* ▶ P.352

▼ **Models with 9" Color Touchscreen with Google built-in**

🔍 Customized Features ▶ P.249



**When Unlocked** The tailgate opens when all doors are unlocked.

▼ **Models with 9" Color Touchscreen**

🔍 Vehicle Settings\* ▶ P.352

▼ **Models with 9" Color Touchscreen with Google built-in**

🔍 Customized Features ▶ P.249

### Using the Power Tailgate Button



To open or close the power tailgate, press the power tailgate button for about one second.

» Some exterior lights flash and the beeper sounds.

#### 1 Power Tailgate Button

- If you press the button again while the power tailgate is moving, it will stop. Press the button for about one second, and the power tailgate will reverse direction.
- If you close the power tailgate when all the doors are locked, the power tailgate locks automatically.
- If you replace the 12-volt battery or the power tailgate fuse while the tailgate is open, the power tailgate may be disabled. The power tailgate resumes once you manually close the tailgate.

🔍 Opening/Closing the Power Tailgate ▶ P.91

## Using the Hands Free Access\*

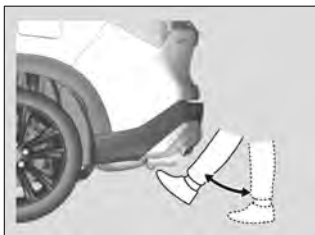

Use a forward and back kicking motion for about 1 second under the center of the rear bumper to open or close the power tailgate while carrying the keyless remote.

» Some exterior lights will flash and a beeper will sound, then the tailgate begins to move.

- Use a forward and back kicking motion for about 1 second.
- During rain or in other instances when the vehicle becomes wet, the sensor may not properly detect your foot motion.



When performing work on or around the rear section of the vehicle, you may inadvertently open or close the tailgate. To prevent this from happening, you can turn off this feature.

 Customized Features ▶ P.249

## Power Tailgate Walk Away Close

When you walk away from the vehicle while carrying the keyless remote, the power tailgate will automatically close.



[1] Carry the keyless remote and press the walk away close button.

» The indicator on the walk away close button will turn green when the walk away close is activated.

### 1 Walk Away Close Button

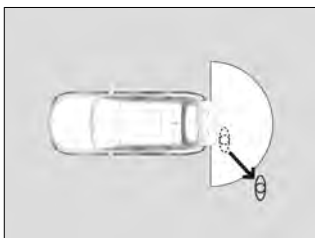

[2] Walk at least 3 feet (1.0 m) away from the vehicle within 30 seconds of pressing the walk away close button.

» Some exterior lights flash and a beeper sounds, then the power tailgate begins to close.

Walk at least 3 feet (1.0 m) away.

\*: Not available on all models

When auto lock function is set to ON, the vehicle will automatically lock when all doors and the tailgate have closed.

Q Locking the Doors and Tailgate (Walk Away Auto Lock®) ▶ P.58

## Programming Tailgate Position

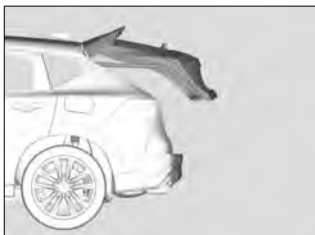

- [1] Open the tailgate to the desired position.
- » If you want to reprogram the power tailgate to open all the way, manually raise the tailgate to its upper most position and follow the directions in step 2.



- [2] Press and hold the tailgate inner button.
- » You will hear one long beep, followed by two short beeps.

### 1 Tailgate Inner Button

- If the tailgate is only slightly opened, the position cannot be programmed, even if you push the inner button.

## Power Tailgate Fall Detection

Automatically lowers the power tailgate when there is a possibility that the fully opened power tailgate can fall down by its own weight (for example, with snow on the tailgate).

» The beeper sounds while the power tailgate lowers.

- If you try to manually close the power tailgate immediately after it fully opens, the power tailgate fall detection may activate.

**!** Once the power tailgate fall detection activates, wait until the power tailgate fully closes. Keep away from the power tailgate when it is in motion.



 If the power tailgate fall detection constantly activates, consult a dealer.

## Auto-Closer

---

If you manually close the power tailgate, it latches automatically.

 Keep your hands away from the tailgate when you manually close the tailgate and let it latch automatically. It is dangerous to put your hands around the tailgate as it starts to latch itself.

# Maximum Load Limit

## About Maximum Load Limit

The maximum load for your vehicle is 850 lbs (385 kg). See the Tire and Loading Information label attached to the driver's doorjamb.

### ⚠ WARNING

Overloading or improper loading can affect handling and stability and cause a crash in which you can be hurt or killed.

Follow all load limits and other loading guidelines in this manual.

## Label Example

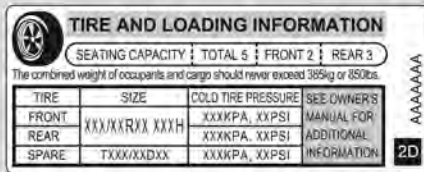

The image shows a rectangular label with a tire icon in a circle on the left. The title is "TIRE AND LOADING INFORMATION". Below the title, it says "SEATING CAPACITY: TOTAL 5 FRONT 2 REAR 3" and "The combined weight of occupants and cargo should never exceed 385kg or 850lbs." Below this is a table with four columns: TIRE, SIZE, COLD TIRE PRESSURE, and SEE OWNER'S MANUAL FOR ADDITIONAL INFORMATION. The table has three rows: FRONT, REAR, and SPARE. The REAR and SPARE rows have placeholder text "XXX/XXRXX XXXH" and "XXXKPA, XXPSI" respectively. To the right of the table is a vertical bar with "AAAAAAA" and a "2D" icon at the bottom right.

TIRE	SIZE	COLD TIRE PRESSURE	SEE OWNER'S MANUAL FOR ADDITIONAL INFORMATION
FRONT	XXX/XXRXX XXXH	XXXKPA, XXPSI	2D
REAR	XXX/XXRXX XXXH	XXXKPA, XXPSI	
SPARE	TXXX/XXDXX	XXXKPA, XXPSI	

This figure includes the total weight of all occupants, cargo, and accessories, and the tongue load if you are towing a trailer.

## Steps for Determining Correct Load Limit-

- 1] Locate the statement “The combined weight of occupants and cargo should never exceed XXX kg or XXX lbs.” on your vehicle’s placard.
- 2] Determine the combined weight of the driver and passengers that will be riding in your vehicle.
- 3] Subtract the combined weight of the driver and passengers from XXX kg or XXX lbs.
- 4] The resulting figure equals the available amount of cargo and luggage load capacity. For example, if the “XXX” amount equals 1,400 lbs. and there will be five 150 lb. passengers

in your vehicle, the amount of available cargo and luggage load capacity is 650 lbs.(1,400 - 750 (5 x 150) = 650 lbs.)

- [5] Determine the combined weight of luggage and cargo being loaded on the vehicle. That weight may not safely exceed the available cargo and luggage load capacity calculated in step 4.
- [6] If your vehicle will be towing a trailer, load from your trailer will be transferred to your vehicle. Consult this manual to determine how this reduces the available cargo and luggage load capacity of your vehicle.

In addition, the total weight of the vehicle, all occupants, accessories, cargo, and trailer tongue load must not exceed the Gross Vehicle Weight Rating (GVWR) or the Gross Axle Weight Rating (GAWR). Both are on a label on the driver's doorjamb.

- Gross Vehicle Weight Rating (GVWR) : The maximum allowable weight of the vehicle, all occupants, all accessories, all cargo.

 About Specifications ▶P.434

- Gross Axle Weight Rating (GAWR) : The maximum allowable weight of the vehicle axle.

 About Specifications ▶P.434

- Towing a Trailer : See Towing a Trailer to determine whether your vehicle is designed to tow a trailer.

 About Towing a Trailer ▶P.100

## Load Limits Example

### Example 1



- 1 Max Load : 850 lbs (385 kg)
- 2 Passenger Weight : 150 lbs x 2 = 300 lbs (68 kg x 2 = 136 kg)
- 3 Cargo Weight : 550 lbs (249 kg)

## Example 2

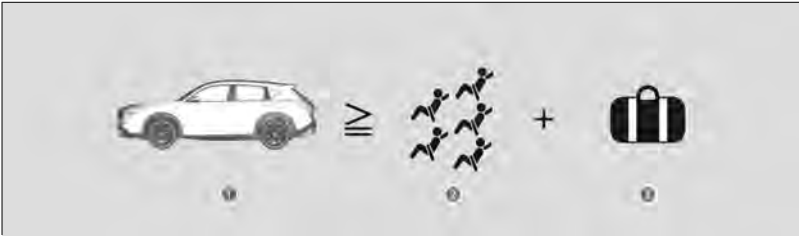

- 1 Max Load : 850 lbs (385 kg)
- 2 Passenger Weight :  $150 \text{ lbs} \times 5 = 750 \text{ lbs}$  ( $68 \text{ kg} \times 5 = 340 \text{ kg}$ )
- 3 Cargo Weight : 100 lbs (45 kg)

# Towing a Trailer

## About Towing a Trailer

Your vehicle is not designed to, and cannot safely, tow a trailer nor have a tow hitch installed. Do not install a tow hitch on, or tow with, your vehicle.

## Towing Behind a Motorhome

Your vehicle is not designed to be towed behind a motor home. If your vehicle needs to be towed in an emergency, refer to the emergency towing information.

 About Towing  P.427

# Off-Highway Driving Guidelines

## General Information

Your vehicle has been designed primarily for use on pavement; however, its higher ground clearance allows you to occasionally travel on unpaved roads. It is not designed for trail-blazing, or other challenging off-highway activities.

If you decide to drive on unpaved roads, you will find that it requires somewhat different driving skills and that your vehicle will handle somewhat differently than it does on pavement. Pay attention to the precautions and tips in this section, and get acquainted with your vehicle before leaving the pavement.

 Failure to operate your vehicle correctly might result in a crash or a rollover.

 [Important Handling Information ▶P.15](#)

 [Precautions While Driving ▶P.19](#)

 Be careful not to spin the tires excessively. This may damage the All-Wheel Drive (AWD) with Intelligent Control System\*.

## WARNING

Improperly operating this vehicle on or off-pavement can cause a crash or rollover in which you and your passengers could be seriously injured or killed.

- Follow all instructions and guidelines in this owner's manual.
- Keep your speed low, and don't drive faster than conditions permit.

## Important Safety Precautions

To avoid loss of control or rollover, be sure to follow all precautions and recommendations:

- Be sure to store cargo properly and do not exceed your cargo load limits.

 [About Maximum Load Limit ▶P.97](#)

- Whenever you drive, make sure you and your passengers always wear seat belts.
- Keep your speed low, and never go faster than the conditions allow.

\*: Not available on all models

- It's up to you to continually assess the situation and drive within the limits.

## Avoiding Trouble

- **Check Out Your Vehicle** before you leave the pavement and make sure that all scheduled maintenance has been completed. Pay special attention to the condition of the tires, and check the tire pressures.
- **Remember** the route you choose presents limits (too steep or bumpy), you have limits (driving skill and comfort), and your vehicle has limits (traction, stability, and power). Failing to recognize these limits will likely put you and your passengers in a hazardous situation.
- **Accelerating and Braking** should be done slowly and gradually. Trying to start or stop too fast can cause a loss of traction and you could lose control.
- **Avoiding Obstacles and Debris** in the road reduces the likelihood of a rollover or damage to your suspension or other components.
- **Driving on Slopes** increases your risk of a rollover, particularly if you attempt to drive across a slope that is too steep. Going straight up or down a slope is usually the safest. If you can't clearly see all conditions or obstacles on a slope, walk it before you drive it. If there is any doubt whether you can safely pass, don't try it. Find another route. If you get stuck when climbing, do not try to turn around. Back down slowly following the same route you took up the hill.
- **Crossing a Stream** - Avoid driving through deep water. If you encounter water in your route (a small stream or large puddle, for example), evaluate it carefully before going ahead. Make sure it is shallow, flowing slowly, and has firm ground underneath. If you are not sure of the depth or the ground, turn around and find another route. Driving through deep water can also damage your vehicle. The water can get into the transmission and differential, diluting the lubricant and causing an eventual failure. It can also wash the grease out of the wheel bearings.
- **If You Get Stuck**, carefully go in the direction that you think will get you unstuck. Do not spin the tires as this will only make things worse and could damage the transmission. If you are unable to free yourself, your vehicle will need to be towed. Front and rear tow hooks are provided for this purpose.

# Driving Operation

## Starting or Stopping the Engine

ENGINE START/STOP Button	104
Starting the Engine	105
Stopping the Engine	106
Remote Engine Start*	106
What to Do If	108

## Shifting

About Shift Operation	110
-----------------------	-----

## Braking

Foot Brake	113
Parking Brake	114
Automatic Brake Hold	116
Anti-lock Brake System (ABS)	119

## Starting and Driving

Starting to Drive	120
-------------------	-----

## Parking Your Vehicle

When Stopped	122
--------------	-----

## Rear View Camera\*

About Rear View Camera	123
------------------------	-----

## Multi View Camera System\*

About Multi View Camera System	125
Using the Multi View Camera System	128
Multi View Camera System Limitations	132

## Refueling

Fuel Information	133
How to Refuel	134

## Fuel Economy and CO<sub>2</sub> Emissions

Improving Fuel Economy and Reducing CO <sub>2</sub> Emissions	136
---	-----

## Turbo Engine Vehicle

Handling Precautions	137
----------------------	-----

## Turn Signals • Light Switches

Turn Signals	138
Headlights/Parking Lights	138

## Wipers and Washers

Windshield Wiper/Washer	145
Rear Wiper/Washer	147
What to Do If	148

## Defroster

Defrosting the Windshield and Windows	149
What to Do If	150

## Heated Windshield Button\*

Heated Windshield Button	151
--------------------------	-----

## Driving Features

Acura Integrated Dynamics System	152
Auto Idle Stop	154
Hill Descent Control System	158
Vehicle Stability Assist™ (VSA®), aka Electronic Stability Control (ESC), System	160
Agile Handling Assist	161
All-Wheel Drive (AWD) with Intelligent Control System*	161
Tire Pressure Monitoring System (TPMS) with Tire Fill Assist	162
Tire Pressure Monitoring System (TPMS) - Required Federal Explanation	163

\*: Not available on all models



# Starting or Stopping the Engine

## ENGINE START/STOP Button

### Changing the Power Mode

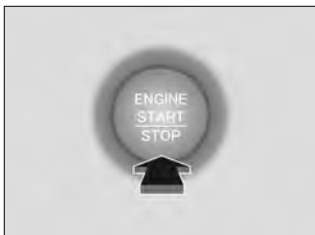

If you carry the keyless remote and press **ENGINE START/STOP** button without depressing the brake pedal, the power mode will change in this order: VEHICLE OFF→ACCESSORY→ON→VEHICLE OFF.

**VEHICLE OFF:**

Vehicle power is turned OFF.

**ACCESSORY:**

The audio system and some accessories can be used.

**ON:**

All accessories can be used.

**ON mode:**

The **ENGINE START/STOP** button is on (in red), if the engine is running.

- Do not leave the power mode in ACCESSORY or ON when you get out.

### Automatic Power Off

If you leave the vehicle for 30 to 60 minutes with the transmission in **P** and the power mode in ACCESSORY, the vehicle automatically goes into the mode similar to VEHICLE OFF (LOCK) to avoid draining the 12-volt battery.

### Power Mode Reminder

If you open the driver's door when the power mode is set to ACCESSORY, a warning beep sounds.

## Starting the Engine

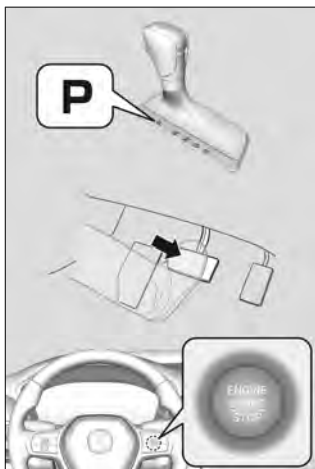

- [1] Make sure the parking brake is applied.  
Q Parking Brake ▶ P.114
- [2] Depress the brake pedal, then press the **ENGINE START/STOP** button while the transmission is in **P**.

- Keep your foot firmly on the brake pedal when starting the engine.
- The engine is harder to start in cold weather and in thinner air found at altitudes above 8,000 feet (2,400 meters).
- When starting the engine in cold weather, turn off all electrical accessories such as the lights, climate control system, and rear defogger in order to reduce the 12-volt battery drain.
- If you live in a region where winter is extremely cold, an engine block heater will improve starting and warming of the engine. Consult a dealer for details.
- Do not hold the **ENGINE START/STOP** button to start the engine.
- If the engine does not start, wait at least 30 seconds before starting the engine again.
- The engine may not start if the keyless remote is subjected to strong radio waves.
- The immobilizer system protects your vehicle from theft. If an improperly coded device is used, the engine's fuel system is disabled.

Q Immobilizer System ▶ P.49

**!** Do not operate the shift lever while pressing the accelerator pedal. You could damage the transmission.

**!** To prevent unexpected accidents, do not depress the accelerator pedal when turning on the engine.

## Stopping the Engine

While the vehicle is completely stopped, put the transmission into **P**, then press the **ENGINE START/STOP** button.

After shutting off the engine, you may hear certain noises coming from under vehicle. This noise is caused by the vacuum pump inside the fuel evaporation leakage check module (ELCM). Depending on conditions, the pump will come on for about 15 minutes about 5 to 10 hours after engine shutdown. This noise doesn't indicate a vehicle problem.

The power mode will automatically turn to VEHICLE OFF about 20 minutes after the following conditions have been met:

- A door has been opened, such as when leaving the vehicle.
- The transmission is in **P**.
- The driver's seat belt is not fastened.

## Remote Engine Start\*

You can remotely start the engine using the two-way keyless remote from extended distances.

- If there are buildings and obstacles between your vehicle and the keyless remote, the range will be reduced. This distance may vary by external electrical interference.

### WARNING

Carbon monoxide gas is toxic and can rapidly accumulate in closed or even partly enclosed areas. Breathing it can cause unconsciousness and even kill you.

Never use the remote engine starter with the vehicle parked in a garage or other areas with limited ventilation.



Before using the remote engine start, check your local laws.  
The remote engine start may violate local laws.

\*: Not available on all models

## To Start the Engine

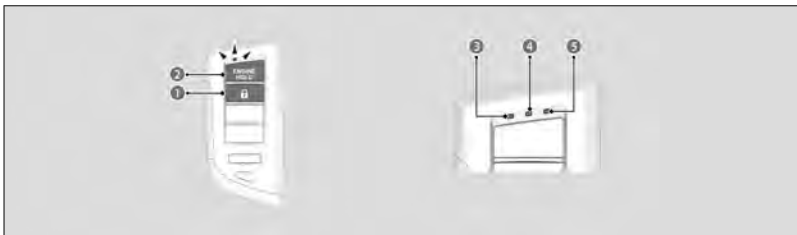

Press the button (1), then press and hold the **ENGINE HOLD** button (2).

**3 Amber LED:** During a vehicle self check, the amber LED continues to blink until the engine starts.

» Blinks when any button is pressed.

**4 Green LED:** Comes on while the engine is running.

**5 Red LED:** Blinks when the keyless remote is out of the keyless system range.

» Go within the range, and try again.

The engine runs for up to 10 minutes without you starting the vehicle. To extend the run time for another 10 minutes during the first run, press the button, then press and hold the **ENGINE HOLD** button.

» The amber LED blinks, then the green LED comes back on if a 10 minute extension request was transmitted successfully.

After pressing the button, wait for the green LED to blink. This indicates that all the doors and the tailgate are locked.

While the engine is running, the vehicle will automatically precondition the interior.

When it is warm outside:

- The climate control system is activated in recirculation mode.
- The seat ventilation is activated\*.

When it is cold outside:

- The defroster is activated at a moderately warm temperature.
- The rear defogger and door mirror heaters are activated.
- The seat heaters and heated steering wheel\* are activated.

[Defrosting the Windshield and Windows](#) ▶ P.149

[Using Heated Steering Wheel](#) ▶ P.179

[Using the Front Seat Heaters/Ventilators](#) ▶ P.177



Before starting the engine, make sure to check the door lock status using the keyless remote.

When you press the button, wait for the green LED to blink. If the red LED turns on, the doors and tailgate did not lock, and the engine does not start.

\*: Not available on all models

## To Stop the Engine

Press the **ENGINE HOLD** button for one second.

- The red LED comes on for one second to let you know that the engine has stopped.
- The red LED blinks when the keyless remote is out of the keyless system range. The engine will not stop.
  - » Go within the range, and try again.

## Remote Engine Start Limitations

The engine may not start by the remote engine start if:

- You have disabled a remote engine start setting.

### ▼ Models with 9" Color Touchscreen

🔍 Vehicle Settings ▶ P.352

### ▼ Models with 9" Color Touchscreen with Google built-in

🔍 Customized Features ▶ P.249

- The power mode is not in VEHICLE OFF.
- The transmission is in a position other than **P**.
- The hood is open, or any door or the tailgate is unlocked.
- You have already used the keyless remote twice to start the engine.
- Another registered keyless remote is in the vehicle.
- There is any antenna failure.
- The door is unlocked with the built-in key.
- The engine oil pressure is low.
- The engine coolant temperature is extremely high.
- The telematics unit malfunctions.
- The security system alarm is not set.
- The 12-volt battery temp is too low or the 12-volt battery charge is too low.
- The keyless remote is left in the vehicle when you get out.

## What to Do If

### ■ If the keyless remote battery is weak

Bring the keyless remote close to the **ENGINE START/STOP** button if the battery in the keyless remote is weak.

🔍 If the Keyless Remote Battery is Weak ▶ P.413

\*: Not available on all models

## ■ Why won't the engine start?

A pre-registered key is required.

 Immobilizer System ▶ P.49

If the keyless remote is set on the instrument panel, in a storage box, or another place where its signal can be interrupted, the power mode may not change.

## ■ Why does the brake pedal sink down slightly when the engine is started?

This is related to the activation of the electric brake system, and it is normal.

## ■ Why does the exhaust system sound abnormal, or why is there an exhaust gas or gasoline smell in the vehicle?

There may be a problem with the engine or exhaust system. Have your vehicle checked by a dealer.

## ■ Why is a motor sound coming from under the hood?

Immediately after starting the engine or while driving, you may hear a motor sound coming from under the hood due to a system check.

## ■ The power mode does not change from ACCESSORY to VEHICLE OFF. Why?

The shift lever should be moved to .

# Shifting

## About Shift Operation



### 1 Shift Lever Release Button

2 Depress the brake pedal and press the shift lever release button to shift.

3 Shift without pressing the shift lever release button.

4 Press the shift lever release button and shift.

**P Park:** Used when parking or starting the engine.

**R Reverse:** Used when reversing.

**N Neutral:** Transmission is not locked.

**D Drive:** Used for normal driving.

- When temporarily driving in the 7-speed manual shift mode

**S Drive (S):** Used for better acceleration.

- To increase engine braking
- When going up or down hills
- When driving in the 7-speed manual shift mode

## Gauge display



1 Shift Position Indicator/Transmission System Indicator

2 M (7-speed manual shift mode) Indicator

3 Shift Indicator

4 Tachometer Red Zone

- Use the shift position indicator to check the lever position before and after pulling away.
- The fuel supply may be cut off if you drive at engine speeds in or over the tachometer's red zone (engine speed limit). If this happens, you may experience a slight jolt.
- It may not be possible to operate the shift lever if the brake pedal is applied while the shift lever release button is held down. Depress the brake pedal first.

- When shifting positions in extremely low temperatures (-22°F/-30°C), there may be a short delay before the shift position is displayed.

**!** When you change **D** to **R** and vice versa, come to a complete stop and keep the brake pedal depressed. Operating the shift lever before the vehicle has come to a complete standstill can damage the transmission.

**!** If the transmission system indicator blinks when driving, in any shift position, there is a problem with the transmission. Avoid sudden acceleration and have the transmission checked by a dealer as soon as possible.

## 7-Speed Manual Shift Mode

Use the paddle shifters to change between 1st and 7th speeds without releasing your hands from the steering wheel. The transmission switches to the 7-speed manual shift mode when you pull a paddle shifter while driving. This mode is useful when engine braking is needed.

### 7-Speed Manual Shift Mode Operation

Each paddle shift operation makes a single speed change. To change continuously, release the paddle shifter before pulling it again for the next speed.



- 1** **-** Paddle shifter: Shift down (Changes to a lower speed number)
- 2** **+** Paddle shifter: Shift up (Changes to a higher speed number)



- In the 7-speed manual shift mode, the transmission shifts up or down by operating either paddle shifter under the following conditions:
  - Shift Up:** The engine speed reaches the lowest threshold of the higher speed position.
  - Shift Down:** The engine speed reaches the highest threshold of the lower speed position.
- In some situations, the system shifts up or down automatically to prevent damage to the engine or transmission.
- Depending on driving conditions, the 7-speed manual shift mode may be disengaged.
- If the shift indicator blinks when you try to shift up or down, this means your vehicle speed is not in its allowable shifting range or the protection of transmission system is necessary. Slightly accelerate to shift up and decelerate to shift down while the indicator is blinking.

### ■ When the transmission is in **D**:

The shift mode goes into the 7-speed manual shift mode temporarily, and the number is displayed in the shift indicator.

The 7-speed manual shift mode is canceled automatically if you drive at constant speed or accelerate, and the number in the shift indicator goes off.

Pulling the **+** paddle shifter for a few seconds will cancel this mode.

The 7-speed manual shift mode is especially useful when reducing the vehicle speed temporarily before making a turn.

### ■ When the transmission is in **S**:

The shift mode goes into the 7-speed manual shift mode. The **M** indicator and the speed number are displayed in the shift indicator. As the vehicle speed slows down, the transmission automatically shifts down accordingly. When the vehicle comes to a stop, it automatically shifts down into 1st.

If the vehicle speed increases and the engine speed reaches near the tachometer red zone, the transmission automatically shifts up.

You can only pull away in 1st speed.

When canceling the 7-speed manual shift mode, move the shift position from **S** to **D** or pull the **+** paddle shifter for a few seconds. When the 7-speed manual shift mode is canceled, the **M** indicator and shift indicator will turn off.

# Braking

## Foot Brake

The foot brake is used to slow down or stop your vehicle. It is operated by a brake pedal.

**!** Check the brakes after driving through deep water, or if there is a buildup of road surface water. If necessary, dry the brakes by lightly depressing the pedal several times.

**!** If you hear a continuous metallic friction sound when applying the brakes, this is caused by the brake wear indicator rubbing on the brake rotor and indicates that the brake pads need to be replaced. Have your vehicle checked by a dealer. If you hear only an occasional squeak or squeal when you initially apply the brake pedal, this may be normal and caused by high frequency vibration of the brake pads against the rotating brake disc.

**!** Do not constantly depress the brake pedal while going downhill, as it builds up heat.  
If you constantly depress the brake pedal while going downhill, it will build up heat, which reduces the brake effectiveness. Apply engine braking by taking your foot off the accelerator pedal and downshifting to a speed position.

**!** Do not rest your foot on the brake pedal while driving, as it will lightly apply the brakes and cause them to lose effectiveness over time and reduce pad life. It will also confuse drivers behind you.

## Brake Assist System

Designed to assist the driver by generating greater braking force when you depress the brake pedal hard during emergency braking. Press the brake pedal firmly for more powerful braking.

» When brake assist operates, the pedal may wiggle slightly and an operating noise may be heard.

## Parking Brake

Use the parking brake to keep the vehicle stationary when parked. When the parking brake is applied, you can manually or automatically release it.

- You may hear the electric parking brake system motor operating from the rear wheel area when you operate the parking brake. This is normal.
- The brake pedal may slightly move due to the electric parking brake system operation when you operate the parking brake. This is normal.
- You cannot apply or release the parking brake if the 12-volt battery goes dead.

 Jump Starting Procedure ▶P.415

- If you pull up and hold the electric parking brake switch while driving, the brakes on all four wheels are applied by the VSA® system until the vehicle comes to a stop. The electric parking brake then applies, and the switch should be released.

### To apply



The electric parking brake can be applied any time the vehicle has battery, no matter which position the power mode is in. Pull the electric parking brake switch (1) gently and securely.

- » The indicator in the switch comes on.
- » The parking brake and brake system indicator (red) comes on for 30 seconds.

### To release



Depress the brake pedal, then press the electric parking brake switch (1).

- » The indicator in the switch goes off.
- » The parking brake and brake system indicator (red) goes off.

- The power mode must be in ON in order to release the electric parking brake.
- Manually releasing the parking brake using the switch helps your vehicle start slowly and smoothly when facing downhill on steep hills.

### Automatic parking brake feature operation

The parking brake is applied automatically when you set the power mode to VEHICLE OFF.

- The default setting for this feature is OFF.

## ■ Activating and deactivating the automatic parking brake feature

With the power mode in ON, carry out the following steps to either activate or deactivate the automatic parking brake feature.

- [1] Put the transmission into **P**.
- [2] Without depressing the brake pedal, pull up the electric parking brake switch.
  - » Check that the Parking Brake and Brake System indicator (red) has come on.
- [3] Pull up and hold the electric parking brake switch. When you hear a beeping sound, release the switch and within three seconds pull up and hold the switch again.
- [4] When you hear a sound indicating that the procedure is completed, release the switch.
  - » Two beeps indicate that the feature has been activated.
  - » One beep indicates that the feature has been deactivated.
  - » To confirm that the parking brake is applied, check if the Parking Brake and Brake System indicator (red) is on.

In the following situations, the parking brake automatically operates.

- When the vehicle stops for more than 10 minutes while ACC with Low Speed Follow is activated.
- When the driver's seat belt is unfastened while your vehicle is stopped automatically by ACC with Low Speed Follow.
- When the engine is turned off, except by Auto Idle Stop system, while ACC with Low Speed Follow is activated.
- When the vehicle stops with the automatic brake hold system activated for more than 10 minutes.
- When the driver's seat belt is unfastened while your vehicle is stopped and brake hold is applied.
- When the engine is turned off, except by Auto Idle Stop system, while the brake hold system is applied.
- When there is a problem with the Brake Hold System while brake hold is applied.



In cold climates, the parking brake may freeze in place if applied. When parking the vehicle, chock the wheels and make sure the automatic parking brake feature is deactivated. Also, when putting your vehicle through a conveyor type car wash or when having your vehicle towed, deactivate the automatic parking brake feature and leave the parking brake released.

## To release automatically

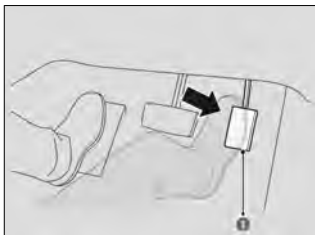

Depress the accelerator pedal (1) to start the vehicle.

» The Parking Brake and Brake System indicator (red) goes off.

The parking brake may not be released automatically while the following indicators are on:

- Malfunction indicator lamp
- Transmission system indicator
- Parking Brake and Brake System indicator (amber)
- VSA® system indicator
- **ABS** indicator
- Supplemental restraint system indicator.



If the driver's seat belt is unfastened, the parking brake will not release automatically.

## Temporarily deactivate the automatic parking brake feature

If you need to temporarily deactivate the feature while putting your vehicle through a conveyor type car wash or when having your vehicle towed, you can follow the procedure explained below.

- [1] Depress the brake pedal and bring the vehicle to a stop.
- [2] Set the power mode to VEHICLE OFF and then within two seconds push down the electric parking brake switch.
  - » Activation and deactivation settings for the feature will not be affected.
  - » Before temporarily deactivating the feature, make sure to first turn off both ACC with Low Speed Follow and the automatic brake hold system.
  - » To confirm that the parking brake is applied, check if the Parking Brake and Brake System indicator (red) is on.

## Automatic Brake Hold

Keeps the brake applied after releasing the brake pedal until the accelerator pedal is pressed. You can use this system while the vehicle is temporarily stopped, like at traffic lights and in heavy traffic.

**⚠ WARNING**

Activating the automatic brake hold system on steep hills or slippery roads may still allow the vehicle to move if you remove your foot from the brake pedal.

If a vehicle unexpectedly moves, it may cause a crash resulting in serious injury or death.

Never activate the automatic brake hold system or rely on it to keep a vehicle from moving when stopped on a steep hill or slippery roads.

Using the automatic brake hold system to park the vehicle may result in the vehicle unexpectedly moving.

If a vehicle moves unexpectedly, it may cause a crash, resulting in serious injury or death.

Never leave the vehicle when braking is temporarily kept by automatic brake hold and always park the vehicle by putting the transmission in **P** and applying the parking brake.

When using the automatic brake hold, keep your foot on the brake pedal until the automatic brake hold indicator comes on.

If the vehicle unexpectedly moves, it may cause a crash resulting in serious injury or death.

Release your foot from the brake pedal after the automatic brake hold indicator comes on.

**How the System Works**

- [1] Fasten your seat belt properly, then start the engine. Press the automatic brake hold button (1).
- » The automatic brake hold system indicator (2) comes on, and then the system goes into standby mode.

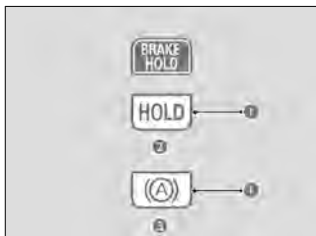

[2] Depress the brake pedal to come to a complete stop while the transmission into **D** or **S**.

- » The automatic brake hold indicator (1) comes on, and then the automatic brake hold is operates. Take your foot off the brake pedal.
- » The automatic brake is held for up to 10 minutes.

2 U.S. models

3 Canada models

- The next time the engine is turned on, if the driver's seat belt is fastened, the system will return to standby mode.

! Make sure to turn off the automatic brake hold system before using an automated car wash.

## System OFF

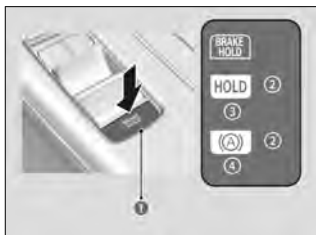

When you press the automatic brake hold button (1), the system is turned off.

If the indicator (2) is lit up, turn off the system while depressing the brake pedal.

3 U.S. models

4 Canada models

- If the system is turned off, it will remain off the next time the engine is started.

## The system automatically cancels when:

- You engage the parking brake.
- You depress the brake pedal and put the shift position into **P** or **R**.

The system automatically cancels and the parking brake is applied when:

- Braking is kept for more than 10 minutes.
- The driver's seat belt is unfastened.
- The engine is turned off.
- There is a problem with automatic brake hold system.

## Anti-lock Brake System (ABS)

Helps prevent the wheels from locking up while driving at 6 mph (10 km/h) or above, and helps you retain steering control by pumping the brakes rapidly, much faster than you can.

- » The electronic brake distribution (EBD) system, which is part of the ABS, also balances the front-to-rear braking distribution according to vehicle loading.
- » You should never pump the brake pedal. Let the ABS work for you by always keeping firm, steady pressure on the brake pedal. This is sometimes referred to as “stomp and steer.”

The brake pedal may pulsate slightly when the ABS is working. Depress the brake pedal and keep holding the pedal firmly down. On dry pavement, you will need to press on the brake pedal very hard before the ABS activates. However, you may feel the ABS activate immediately if you are trying to stop on snow or ice.

- The ABS is not designed for the purpose of reducing the time or distance it takes for a vehicle to stop: It is designed to limit brake lockup, which can lead to skidding and loss of steering control.



The ABS may not function correctly if you use a tire of the incorrect size or type.



If the **ABS** indicator comes on while driving, there may be a problem with the system.

While normal braking will not be affected, there is a possibility that the ABS will not be operating. Have your vehicle checked by a dealer immediately.



# Starting and Driving

## Starting to Drive

- [1] Keeping your right foot on the brake pedal, select the shift position.
  - » If you started the engine with the remote engine start feature, depress the brake pedal and press the **ENGINE START/STOP** button before changing the shift position.
- [2] Release the brake pedal and gently depress the accelerator pedal.
  - » The parking brake will release automatically. You can also release it by operating the parking brake switch.

 Parking Brake ▶ P.114

When the engine was started with remote engine start feature, the engine stops when the shift position is taken out of **P** before the **ENGINE START/STOP** button is pressed.

- » To start driving, restart the engine and follow step 1.

 Starting the Engine ▶ P.105

 If the power mode is set to ACCESSORY while driving, the engine will shut down and all steering and brake power assist functions will stop, making it difficult to control the vehicle.

 Do not select **N** while driving as you will lose engine braking (and acceleration) performance.

 During the first 600 miles (1,000 km) of operation, avoid sudden acceleration or full throttle operation so as not to damage the engine or powertrain.

 Avoid hard braking for the first 200 miles (300 km) after purchasing your new vehicle or replacing the brake pads or rotors, to allow for proper break-in.

## Hill start assist system

Hill start assist keeps the brake engaged briefly to help prevent the vehicle from rolling on inclines as you move your foot from the brake pedal to the accelerator.

Put the transmission into **D** or **S** when facing uphill, or **R** when facing downhill, then release the brake pedal.

- » Hill start assist may not prevent the vehicle from rolling downhill on a very steep or slippery slope, and will not operate on small inclines.
- » Hill start assist is not a replacement for the parking brake.

## Continuously Variable Transmission

### Creeping

This vehicle creeps when the shift position is in **D**, **S**, or **R**.

- » Keep the brake pedal firmly depressed when stopped or ensure that brake-hold is engaged.

 Automatic Brake Hold System ▶P.116

### Kickdown

Quickly depressing the accelerator pedal while driving uphill may cause the transmission to drop to a lower ratio, unexpectedly increasing vehicle speed. Depress the accelerator pedal carefully, especially on slippery roads and curves.

## Driving Guidelines for Your Utility Vehicle

Utility vehicles have a significantly higher rollover rate than other types of vehicles. To prevent rollovers or loss of control:

- Take corners at slower speeds than you would with a passenger vehicle.
- Avoid sharp turns and abrupt maneuvers whenever possible.
- Do not modify your vehicle in any way that would raise its center of gravity.
- Do not carry heavy cargo on roof.
- Roof load capacity is 132 lbs (60 kg), available roof racks/carriers may have lower capacities. Please check accessory's information (Acura accessory).

Failure to operate your vehicle correctly might result in a crash or a rollover.

 Important Handling Information ▶P.15

 Precautions While Driving ▶P.19

# Parking Your Vehicle

## When Stopped

- [1] Depress the brake pedal firmly and come to a complete stop.
- [2] With the brake pedal depressed, pull up the electric parking brake switch slowly, but fully.
- [3] Change the shift position to **P**.

### CAUTION

The vehicle can roll away if left unattended without confirming that Park is engaged. A vehicle that rolls away could cause a crash resulting in serious injury or death.

Always keep your foot on the brake pedal until you have confirmed that **P** is shown on the shift position indicator.

 Always set the parking brake, especially if you are parked on an incline.

 The following can damage the transmission:

- Depressing the accelerator and brake pedals simultaneously.
- Changing the shift position into **P** before the vehicle stops completely.
- Bringing the vehicle to a stop while adjusting the accelerator pedal on an incline.

 Do not park your vehicle near flammable objects. Heat from the exhaust can cause a fire.

 In extremely cold temperatures, do not apply the parking brake but if parking on a slope, either turn the front wheels so they will contact the curb if the vehicle rolls down the slope or block the wheels to keep the vehicle from moving.

If you do not take either precaution, the vehicle may roll unexpectedly, leading to a crash.

# Rear View Camera\*

## About Rear View Camera

The audio/information screen can display your vehicle's rear view. The display automatically changes to the rear view when the transmission is put into **R**.

- Visually confirm that it is safe to drive before backing up. Certain conditions (such as weather, lighting, and high temperatures) may also restrict the rear view. Do not rely on the rearview display which does not give you all information about conditions at the back of your vehicle.
- If the camera lens is covered with dirt or moisture, use a soft, moist cloth to keep the lens clean and free of debris.
- The camera view is restricted. You cannot see the corner ends of the bumper or what is underneath the bumper. Its unique lens also makes objects appear closer or farther than they actually are.





**!** If the vehicle's rear view is not displayed on the audio/information screen while the shift position is in **R**, there may be a problem with the system. Have your vehicle checked by a dealer immediately.

## Switching Camera Modes

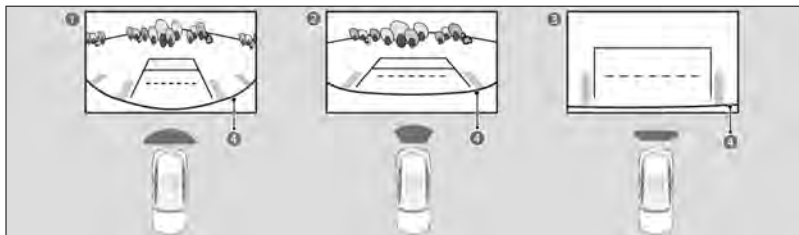
You can view three different camera modes on the screen.

Select appropriate icon to switch the mode.



- 1  Wide view mode
- 2  Normal view mode
- 3  Top down view mode
- 4  Bumper

- If you were last using Wide view mode or Normal view mode, the same view mode will be activated the next time you put the transmission into **R**.
- If you were using Top down view mode before you turned off the engine, Wide view mode will be activated the next time you set the power mode to ON and put the transmission into **R**.

\*: Not available on all models

- If you were using Top down view mode and 10 seconds elapsed after you took the transmission out of **R**, Wide view mode will be activated the next time you put the transmission into **R**.
- If you were using Top down view mode and put the transmission back into **R** within 10 seconds after you took it out of **R**, Top down view mode will be activated.

## Distance between the vehicle and guideline

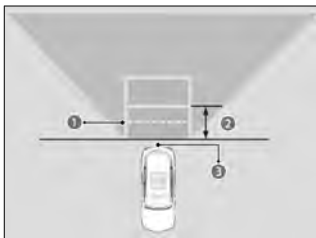

- 1 Tailgate open range
- 2 Approx. 39 inches (1 m)
- 3 Camera



You can change the **Fixed Guideline** and **Dynamic Guideline** settings.

🔍 Customized Features ▶ P.214

# Multi View Camera System\*

## About Multi View Camera System

Multi View Camera System is a four camera system that views areas commonly known as “blind spots” from different angles, then displays the images on the audio/information screen. This system can be used to:

- Check the right and left sides of the vehicle while crossing at intersections with poor visibility (fog, heavy rain, obstructed view, etc.).

 [Checking the Front of Your Vehicle](#) ▶ P.128

- Check for obstacles in front of the vehicle when parking or maneuvering in confined areas.

 [Checking the Front of Your Vehicle](#) ▶ P.128

 [Checking the Sides of Your Vehicle](#) ▶ P.129

- Check for obstacles when you are moving in **R**.

 [Checking for Obstacles at the Back of Your Vehicle](#) ▶ P.130

- The multi view camera system does not eliminate all blind spots. The system is for your convenience only.
- Always keep the camera lenses clean and free from debris.

### WARNING

Failure to visually assess the area around the vehicle (directly or by use of the mirrors) may result in a crash causing serious injury or death.

The areas shown in the multi view camera system display are limited. The display may not show all pedestrians or other objects around your vehicle. Do not solely rely only on the multi view camera system display to assess whether it is safe to move your vehicle.

Failure to pay proper attention to your surroundings while driving may result in a crash causing serious injury or death.

To help mitigate the chances of a collision, only look at the multi view camera system display when it is safe to do so.

\*: Not available on all models

## Displaying a Camera Image



### To display frontal views:

Press the  button (1) when the shift position is in a position other than **R**.

### To display rear reviews:

Change the shift position to **R** when the vehicle is stationary.



You can also display the camera image using the camera icon (1).

- When the parking sensor system or camera detects any obstacles, the indicator will display.

 About Parking Sensor System ▶ P.330

- The Cross Traffic Monitor system alerts you when a vehicle is approaching your vehicle from the rear corner.

 About Cross Traffic Monitor ▶ P.326



You can customize the display setting.

 Customized Features ▶ P.249

## Camera Locations and Images

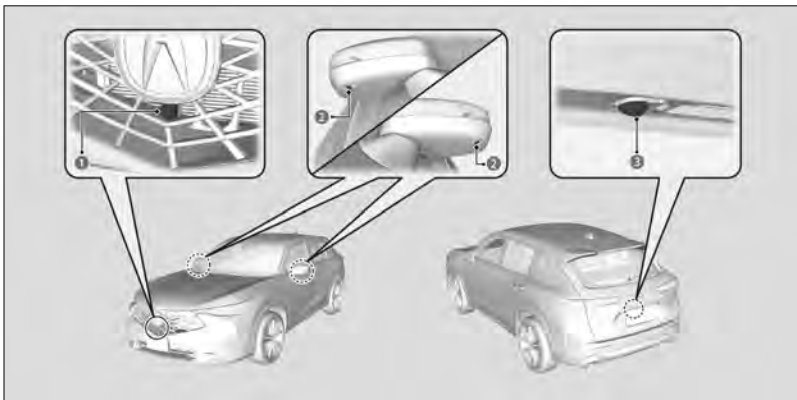

- 1 Front View Camera
- 2 Side View Camera
- 3 Rear View Camera

The unique multi view camera lenses make distances appear differently than they actually are – objects seen on the audio/information screen may appear closer or further away, and may be distorted. This becomes more apparent the further away an object is from your vehicle.

### Front Side Display

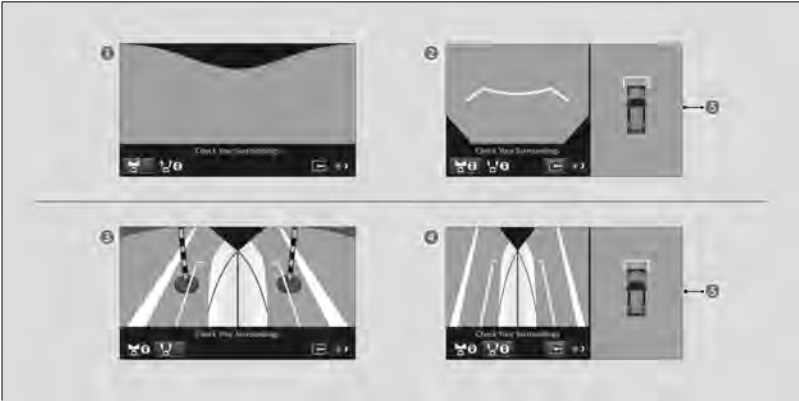

- 1 Front Blind View
- 2 Front View + Ground View
- 3 Side View
- 4 Side View + Ground View
- 5 Ground View: An overhead view created by the combination of images captured by four cameras.

### Rear Side Display

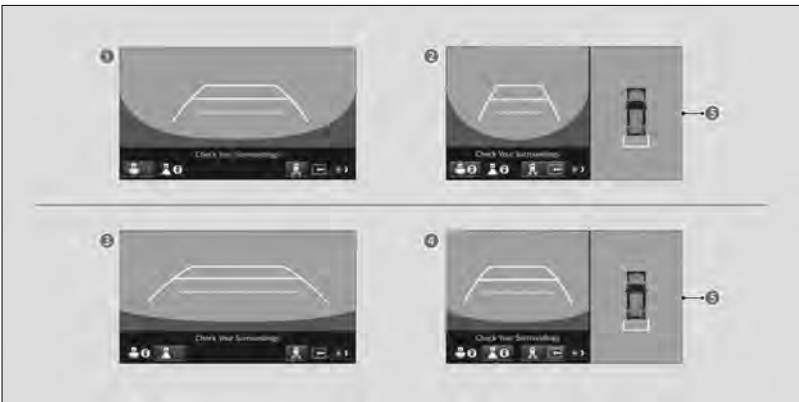



- ① Rear Wide View    ② Rear Wide View + Ground View    ③ Rear Normal View
- ④ Rear Normal View + Ground View    ⑤ Ground View: An overhead view created by the combination of images captured by four cameras.

## Reference Lines and Guides

The following can be displayed when the system is on:

**Fixed Guideline:** Helps you get a sense of a distance between your vehicle and the rear surroundings.

**Dynamic Guideline:** Indicates vehicle direction while the steering wheel is in the current position.



The guidelines can be turned on and off using the audio/information screen.

Customized Features ▶ P.249



The guidelines should be used as a reference only.

The positions/distances indicated by the guidelines and camera views on the display may differ from the actual positions/distances due to the changes in the vehicle height, road conditions, and other factors.

## Using the Multi View Camera System

### Checking the Front of Your Vehicle

Press the button to display the front view screen.

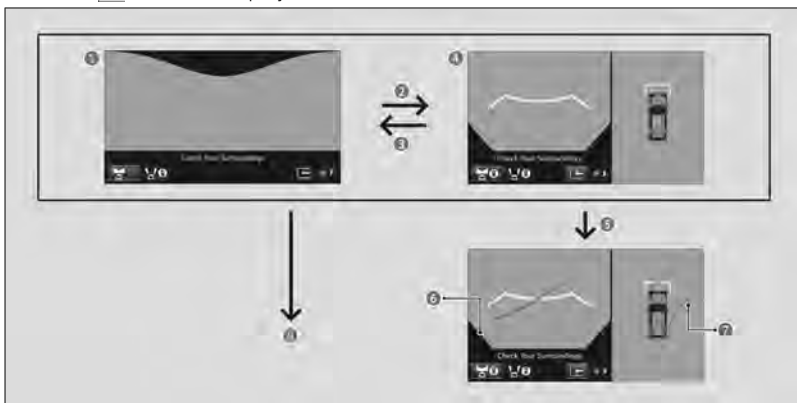



① Front Blind View

② or

③ or

④ Front View + Ground View

- 5 When the steering wheel is turned more than 90 degrees.
- 6 Blind spots appear in black.
- 7 The projection lines appear approx. 10 inches (25 cm) outside the vehicle body.
- 8 Pressing , , or  buttons switches to the side view screen.

- When the vehicle speed exceeds 15 mph (25 km/h), the front view on the screen automatically switches to the audio information screen.
- The ground view can be displayed even with the door mirrors folded. However, the viewable angle and blind spot change.

### Camera display area



The angle provided by the front blind view screen (1) is 180 degrees.

The front blind view screen is useful when you need to check for vehicles crossing from either direction at an intersection with poor visibility.



» The front blind view is a wide-angled view. The image will be largely distorted, and objects may appear closer or more distant than they actually are.

### Distance between the vehicle and guideline



The distance (1) from the vehicle to the guideline is approx. 39 inches (1 m).

## Checking the Sides of Your Vehicle

While displaying the front view screen, press the , , or  buttons to display the side view screen.

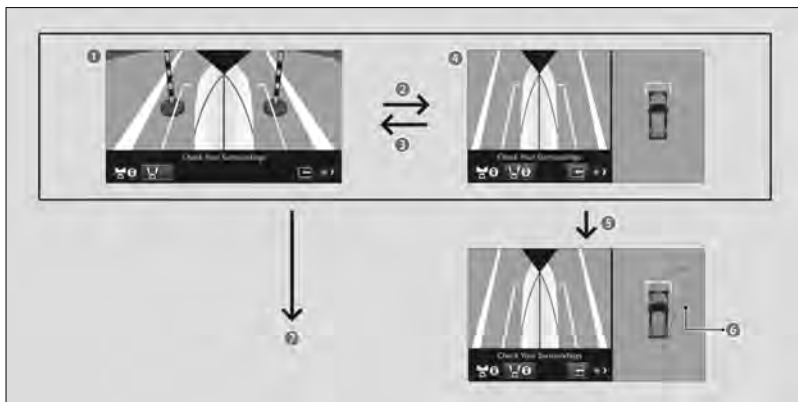

1 Side View

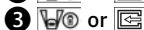

4 Side View + Ground View

5 When the steering wheel is turned more than 90 degrees.

6 The dynamic guidelines appear approx. 10 inches (25 cm) outside the vehicle body.

7 Pressing or switches to the front view screen.

- When the vehicle speed exceeds 15 mph (25 km/h), the side view on the screen automatically switches to the audio information screen.
- The ground view can be displayed even with the door mirrors folded. However, the viewable angle and blind spot change.

### Distance between the vehicle and guidelines

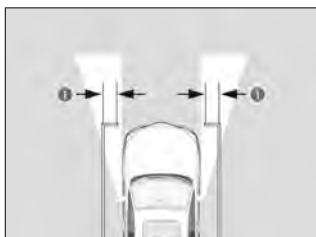

Images of the front side of the vehicle captured by side cameras are displayed on the display. Approximate distance (1) the projection lines indicate is 12 inches (30 cm) from the vehicle.





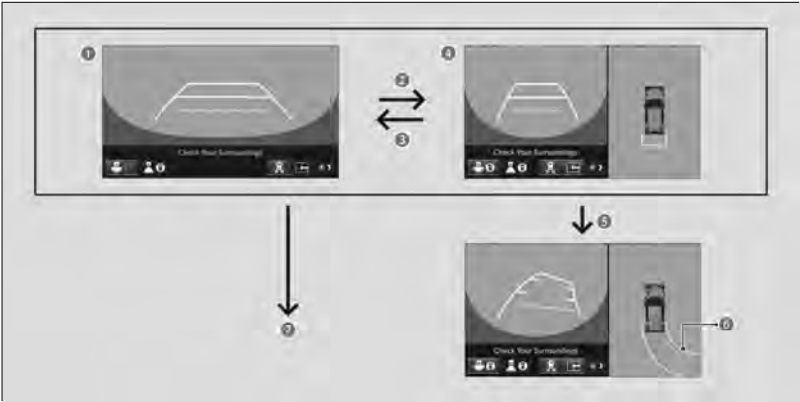

### Checking for Obstacles at the Back of Your Vehicle

The display automatically changes to the rear view when the gear position is changed to **R**.

- When changing the shift position from/to **R**, you may experience a delay in switching between the other screen and a rear view image.





## Rear Wide View



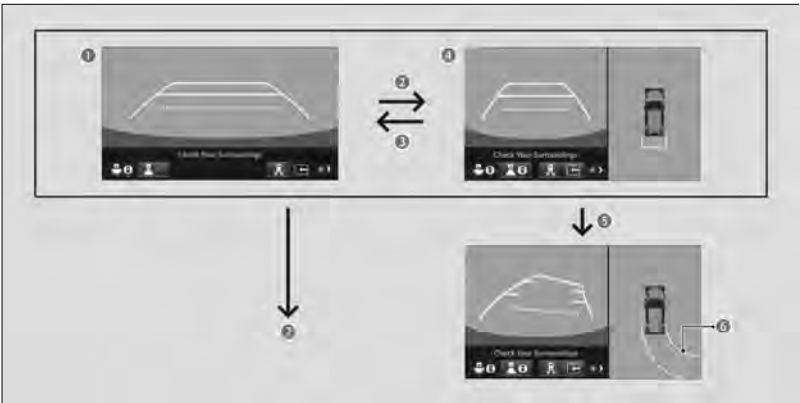

- 1 Rear Wide View
- 2  or 
- 3  or 
- 4 Rear Wide View + Ground View
- 5 When the steering wheel is turned more than 90 degrees.
- 6 The dynamic guidelines appear approx. 10 inches (25 cm) outside the vehicle body.
- 7 Pressing ,  or  buttons switches to the rear view screen.

## Rear Normal View



- 1 Rear Normal View
- 2  or 
- 3  or 
- 4 Rear Normal View + Ground View

- 5 When the steering wheel is turned more than 90 degrees.
- 6 The dynamic guidelines appear approx. 10 inches (25 cm) outside the vehicle body.
- 7 Pressing ,  or  buttons switches to the rear wide view screen.

## Distance between the vehicle and guidelines

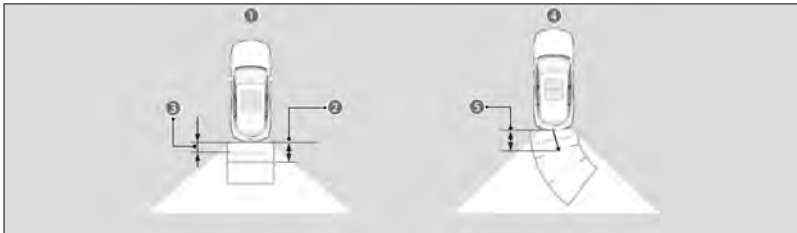

- 1 Approximate distances the guidelines indicate
- 2 39 inches (1.0 m)
- 3 22 inches (56 cm)
- 4 Approximate distances the projection lines indicate
- 5 39 inches (1.0 m)

## Multi View Camera System Limitations

Clean camera lenses with a soft cloth moisturized with water, mild detergent, or glass cleaner.

The camera may become blurry under the following conditions. In these cases, we recommend checking visually without using the multi view camera system.

- You activate the system in bad weather (heavy rain, snow, fog, etc.) or in the dark.
- Camera temperatures are high.
- A sudden change between light and dark, such as an entrance or exit of a tunnel.
- You drive into the sunlight (e.g., at dawn or dusk.)

Have your vehicle checked by a dealer in the following situations:

- When the dynamic guideline becomes inaccurate.
- A camera lens is scratched.
- A camera or the area around the camera has been severely impacted.
- An error message is displayed while the multi view camera system is in use.
- The camera image is not displayed on the screen while driving at speeds below 12 mph (20 km/h).

# Refueling

## Fuel Information

### Fuel recommendation

#### Unleaded premium gasoline, pump octane number 91 or higher

Use of a lower octane gasoline can cause occasional metallic knocking noise in the engine and will result in decreased engine performance.

Use of a gasoline with a pump octane less than 87 can lead to engine damage.

» Use of gasoline with these additives may adversely affect performance, and cause the malfunction indicator lamp on your instrument panel to come on. If this happens, contact a dealer for service. Some gasoline today is blended with oxygenates such as ethanol. Your vehicle is designed to operate on oxygenated gasoline containing up to 15% ethanol by volume. Do not use gasoline containing methanol. If you notice any undesirable operating symptoms, try another service station or switch to another brand of gasoline.

### Top tier detergent gasoline

Because the level of detergency and additives in gasoline vary in the market, Acura endorses the use of “TOP TIER Detergent Gasoline” where available to help maintain the performance and reliability of your vehicle. TOP TIER Detergent Gasoline meets a new gasoline standard jointly established by leading automotive manufacturers to meet the needs of today’s advanced engines.

Qualifying gasoline retailers will, in most cases, identify their gasoline as having met “TOP TIER Detergent Gasoline” standards at the retail location. This fuel is guaranteed to contain the proper level of detergent additives and be free of metallic additives. The proper level of detergent additives, and absence of harmful metallic additives in gasoline, help avoid buildup of deposits in your engine and emission control system.

For further important fuel-related information for your vehicle, or on information on gasoline that does not contain MMT, visit Acura Owners at [mygarage.acura.com](http://mygarage.acura.com). In Canada, visit [www.acura.ca](http://www.acura.ca) (English)/[www.acura.ca/fr](http://www.acura.ca/fr) (French) for additional information on gasoline. For more information on top tier gasoline, visit [www.toptiergas.com](http://www.toptiergas.com).



We recommend quality gasoline containing detergent additives that help prevent fuel system and engine deposits. In addition, in order to maintain good performance, fuel economy, and emissions control, we strongly recommend the use of gasoline that does NOT contain harmful manganese-based fuel additives such as MMT, if such gasoline is available.

## Fuel tank capacity

14.0 US gal (53 L)

### How to Refuel

Your fuel tank is not equipped with a fuel filler cap. You can insert the filler nozzle directly into the filler neck. The tank seals itself again when you pull out the filler nozzle.



- [1] Stop your vehicle with the service station pump on the left side of the vehicle in the rear.
- [2] Turn off the engine and then unlock the driver's door.
  - » The fuel fill door on the outer side of the vehicle will unlock.
- [3] Press and release the area indicated by the arrow (1). You will hear a click and the lid will open slightly.
- [4] Manually pull the fuel fill door to a fully open position.

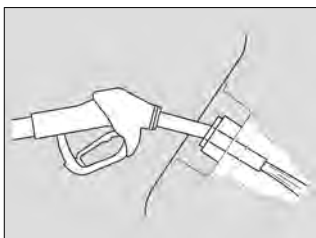

- [5] Place the end of the filler nozzle on the lower part of filler opening, then insert it slowly and fully.
  - » Make sure that the end of the filler nozzle goes down along with the filler pipe.
  - » Keep the filler nozzle level.
  - » When the tank is full, the filler nozzle will click off automatically.
  - » If you do not fill up the tank to full, always add a minimum of **1.3 US gal (5 L)** of fuel.
  - » After filling, wait about five seconds before removing the filler nozzle.
- [6] Shut the fuel fill door by hand.

- The fuel filler opening is designed to accept only service station filler nozzles for refueling. Use of smaller diameter tubes (e.g., those used to siphon fuel for other uses) or other non-service station devices can damage the area in and around the filler opening.
- The filler nozzle automatically stops to leave space in the fuel tank so that fuel does not overflow as a result of changes in air temperature. Do not continue to add fuel after the filler nozzle has automatically stopped. Additional fuel can exceed the full tank and cause fuel to spill.
- If you repeatedly fill the tank with less than the specified minimum amount of fuel, the malfunction indicator lamp may come on. If this happens, have your vehicle checked by a dealer.

- Use the lock tab or the master door lock switch to unlock the fuel fill door. The vehicle doors and fuel fill door automatically relock if the remote unlock function is used. This can be deactivated by briefly opening then closing the driver's door.
- Using the Walk away auto lock\* feature will also lock the fuel fill door. Always make sure both the driver's door and fuel fill door are unlocked before attempting to open the fuel fill door.

 Locking the Doors and Tailgate (Walk Away Auto Lock®) ▶ P.58

- If the filler nozzle keeps turning off when the tank is not full, there may be a problem with the pump's fuel vapor recovery system. Try filling at another pump. If this does not fix the problem, consult a dealer.
- If you have to refuel your vehicle from a portable container, use the funnel provided with your vehicle.

 Refueling From a Portable Fuel Container ▶ P.430

## WARNING

Gasoline is highly flammable and explosive.

You can be burned or seriously injured when handling fuel.

- Stop the engine, and keep heat, sparks, and flames away.
- Handle fuel only outdoors.
- Wipe up spills immediately.



Do not close the fuel fill door forcibly when the driver's door is locked.

The fuel fill door and its latching mechanism can be permanently damaged.



# Fuel Economy and CO<sub>2</sub> Emissions

## Improving Fuel Economy and Reducing CO<sub>2</sub> Emissions

Achieving fuel economy and reducing CO<sub>2</sub> emissions is dependent on several factors, including driving conditions, load weight, idling time, driving habits, and vehicle condition. Depending on these and other factors, you may not achieve the rated fuel economy of this vehicle.

Direct calculation is the recommended method to determine actual fuel consumed while driving.

**Miles driven ÷ Gallons of fuel = Miles per Gallon**

**100 × Liters of fuel ÷ Kilometers driven = L per 100 km**

In Canada, posted fuel economy numbers are established following a simulated test. For more information on how this test is performed, please visit <https://www.nrcan.gc.ca> and search for “fuel consumption testing” in the search field at the top of the page.

## Maintenance and Fuel Economy

You can optimize your fuel economy with proper maintenance of your vehicle. Always maintain your vehicle in accordance with the messages displayed on the gauge.

- Use engine oil with the viscosity recommended.

 Recommended Engine Oil ▶ P.368

- Maintain the specified tire pressure.
- Do not load the vehicle with excess cargo.
- Keep your vehicle clean. A buildup of snow or mud on your vehicle's underside adds weight and increases wind resistance.

# Turbo Engine Vehicle

## Handling Precautions

The turbocharger is a high-precision device to obtain greater horsepower by delivering a large volume of compressed air into the engine using a turbine driven by the engine's exhaust gas pressure.

- When the engine is cold just after starting, avoid revving the engine or sudden acceleration.
- Always replace the engine oil and engine oil filter according to the Maintenance Minder.
- The turbine rotates at very high speeds over 100,000 rpm and its temperature reaches over 1,292°F (700°C). It is lubricated and cooled by engine oil. If you fail to replace the engine oil and filter at the scheduled distance or interval, deteriorated engine oil may cause failure such as sticking and abnormal noise of the turbine bearing.

The scheduled maintenance intervals for replacing the filter is indicated on the gauge. Follow the information of when to replace them.

 About Maintenance Minder™ ▶ P.361

The temperature gauge pointer is at the **H** mark when you restart the engine after driving under high load conditions such as at high speed or in hilly terrain. This is normal. The gauge goes down after you idle or drive the vehicle for about one minute.

# Turn Signals • Light Switches

## Turn Signals

Push the lever up or down based on the direction you want to turn, and the turn signal will blink.

The  turn signal indicator will blink when the external turn signal blinks.

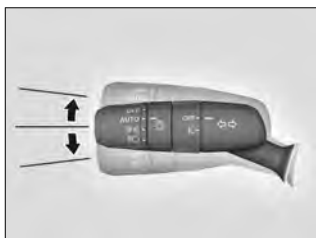

When you lightly push the lever up or down and release it, the turn signal will blink 3 times.

» If you lightly push the lever in the opposite direction while it is blinking, the blinking will stop.

## Headlights/Parking Lights

The lights will turn on automatically depending on the ambient brightness.

They can also be switched on and off manually.

» The  lights on indicator in the instrument panel will turn on.

The exterior lights will switch on automatically when the light switch is set to **AUTO** while the power mode is in ON.

## Manual operation

### Headlights/parking lights:

Turn the light switch to .

### Parking lights:

Turn the light switch to .

### Headlight/parking lights off:

Turn the light switch to **OFF** and release it while the shift position is in **P** or the parking brake is applied.

- The lights will come back on automatically when:
  - » The light switch is turned to **OFF** again and released.
  - » The shift position is changed out of **P** and the parking brake is released.

When the parking lights are on, the taillights and rear license plate light will also switch on.

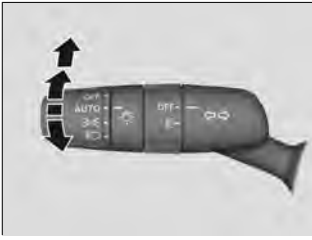

The light sensor is in the location shown below.  
Do not cover the light sensor.

▼ **Models without automatic intermittent wipers**

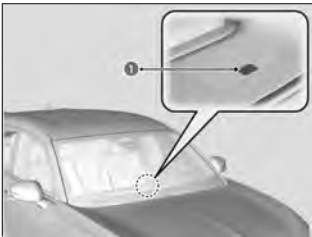

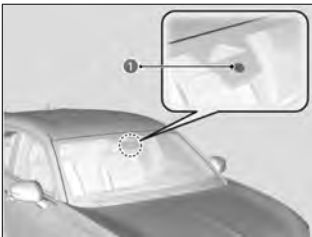

① Light Sensor

▼ **Models with automatic intermittent wipers**



① Light Sensor

When the light switch is turned to  or  and the power is turned to OFF, a beeper sounds when the driver's door is opened.

- !** When the light switch is turned to **AUTO** and the ambient light levels are low, the headlights and parking lights will switch on if you unlock a door. They will switch off when the door is locked.

## High Beams

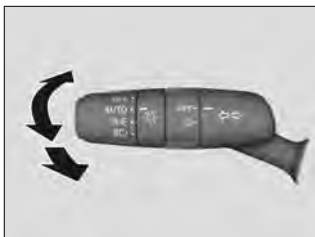

When the headlights are on, push the lever forward.

Pull the lever back to return to low beams.

The  high beam indicator in the instrument panel will turn on when the high beams are on.

- Flashing the high beams: Pull the lever back, and release it.

## Headlight Integration with Wipers

The headlights automatically come on when the wipers are used several times within a certain number of intervals with the headlight switch in **AUTO**.

The headlights automatically go off a few minutes later if the wipers are stopped.

This feature activates while the headlights are off in **AUTO**.

The instrument panel brightness does not change when the headlights come on.

At dark ambient light levels, the automatic lighting control feature turns on the headlights, regardless of the number of wiper sweeps.



You can turn the headlight integration with wipers function on and off.

### ▼ Models with 9" Color Touchscreen

 Vehicle Settings\*  P.352

### ▼ Models with 9" Color Touchscreen with Google built-in

 Customized Features  P.249

## Automatic Lighting Off Feature

The headlights, all other exterior lights, and the instrument panel lights turn off 15 seconds after you set the power mode to VEHICLE OFF, take the keyless remote with you, and close the driver's door.

If you set the power mode to VEHICLE OFF with the headlight switch on but do not open the door, the lights turn off after 10 minutes (3 minutes if the switch is in the **AUTO** position).

The lights turn on again when you unlock or open the driver's door.

If you unlock the door, but do not open it within 15 seconds, the lights go off.

If you open the driver's door, you will hear a reminder chime alerting you that the lights are on.



You can change the headlight auto off timer setting.

▼ **Models with 9" Color Touchscreen**

🔍 Vehicle Settings\* ▶ P.352

▼ **Models with 9" Color Touchscreen with Google built-in**

🔍 Customized Features ▶ P.249

## Fog Lights\*

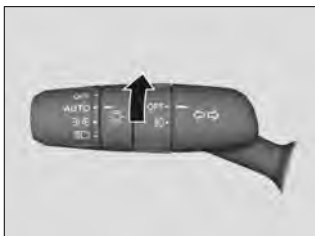

Can be used when the low beam headlights are on.

Turn the fog light switch on to use the fog lights.

» The  fog light indicator in the instrument panel will turn on.

## Chicane™ Daytime Running Lights

The parking/daytime running lights come on when the following conditions have been met:

- The power mode is in ON.
- The headlight switch is in **AUTO** or .
- The parking brake is released.

The lights remain on even if you set the parking brake.

Setting the power mode to VEHICLE OFF will turn off the daytime running lights.

The daytime running lights are off once the headlight switch is turned on, or when the headlight switch is in **AUTO** and it is getting darker outside.

## Auto High-Beam

The front wide view camera detects the light sources ahead of the vehicle such as the lights of a preceding or oncoming vehicle, or street lights. When you are driving at night, the system automatically switches the headlights between low beam and high beam depending on the situation.

### How to Use the Auto High-Beam

#### Activating the system

When all of the following conditions have been met, the auto high-beam indicator comes on and automatically switches between the high beam and low beam, depending on the situation.

\*: Not available on all models



- The power mode is in ON.
- The light switch is in **AUTO**.
- The lever is in the low beam position.
- The headlights have been automatically activated.
- It is dark outside the vehicle.

### 1 Auto High-Beam Indicator

### 2 Light Switch

If the auto high-beam indicator does not come on even when all the conditions have been met, carry out either of the procedures below and the indicator will come on.

- Pull the lever toward you and release it.
- Turn the light switch to  then turn the light switch to **AUTO**.

The auto high-beam system does not always operate in every situation. This system is just for assisting the driver. Always observe your surroundings and manually switch the headlights between high beam and low beam if necessary.

- The range and the distance at which the camera can recognize light sources varies depending on conditions surrounding your vehicle.

For the auto high-beam to work properly:

- Do not place an object that reflects light on the dashboard.
- Keep the windshield around the camera clean.
- When cleaning the windshield, be careful not to apply the windshield cleanser to the camera lens.
- Do not attach an object, sticker, or film to the area around the camera.
- Do not touch the camera lens.

Regarding the handling of the camera mounted to the inside of the windshield, refer to the following.

 [Front Wide View Camera](#) ▶ P.280

If the camera receives a strong impact, or repairing of the area near the camera is required, consult a dealer.

### How to turn off the Auto High-Beam System

You can turn the auto high-beam system on and off.

#### ▼ Models with 9" Color Touchscreen

 [Vehicle Settings\\*](#) ▶ P.352

#### ▼ Models with 9" Color Touchscreen with Google built-in

 [Customized Features](#) ▶ P.249

If you find the timing of beam changes inconvenient for driving, change the headlight beams manually.

If the **Some driver assist systems cannot operate: Camera temperature too high** message appears:

- Use the climate control system to cool down the interior and, if necessary, also use defroster mode with the airflow directed toward the camera.
- Start driving the vehicle to lower the windshield temperature, which cools down the area around the camera.

If the **Some driver assist systems cannot operate: Clean front windshield or poor viewing condition.** message appears:

- Park your vehicle in a safe place, and clean the windshield. If the message does not disappear after you have cleaned the windshield and driven for a while, have your vehicle checked by a dealer.

## Automatic switching between high-beam and low-beam

When auto high-beam is active, the headlights switch between high beam and low beam based on the following conditions.

### High beam

All of the following conditions must be met before the high beams turn on.

- Your vehicle speed is 23 mph (37 km/h) or more.
- There are no preceding or oncoming vehicles with headlights or taillights turned on.
- There are few street lights on the road ahead.

### Low beam

One of the following conditions must be met before the low beams turn on.

- Your vehicle speed is 15 mph (24 km/h) or less.
- There is a preceding or oncoming vehicles with headlights or taillights turned on.
- There are many street lights on the road ahead.

## Manual switching between high-beam and low-beam

If you want to manually switch the headlights between high beam and low beam, follow either of the procedures below. Note that when you do this, the auto high-beam indicator will turn off and the auto high-beam will be deactivated.

### Using the lever :

Pull the lever toward you for flashing the high beams then release it.

- » To reactivate the auto high-beam, follow either of the procedures below and the auto high-beam indicator will come on.
  - Pull the lever toward you and release it.
  - Turn the light switch to  and then to **AUTO** when the lever is in the low beam position.

### Using the light switch :

Turn the light switch to .

- » To reactivate the auto high-beam, turn the light switch to **AUTO** when the lever is in the low beam position, and the auto high-beam indicator will come on.



In the following cases, the auto high-beam system may not switch the headlights properly or the switching timing may be changed. If the automatic switching operation does not fit your driving habits, please switch the headlights manually.

- The brightness of the lights from a preceding or oncoming vehicle is intense or poor.
- Visibility is poor due to the weather (rain, snow, fog, windshield frost, etc.).
- Surrounding light sources like street lights, electric billboards, and traffic lights are illuminating the road ahead.
- The brightness level of the road ahead constantly changes.
- The road is bumpy or has many curves.
- A vehicle suddenly appears in front of you, or a vehicle in front of you is not in the preceding or oncoming direction.
- Your vehicle is tilted with a heavy load in the rear.
- A traffic sign, mirror, or other reflective object ahead is reflecting strong light toward the vehicle.
- The oncoming vehicle frequently disappears under roadside trees or behind median barriers.
- The preceding or oncoming vehicle is a motorcycle, bicycle, mobility scooter, or other small vehicle.

The auto high-beam system keeps the headlight low beam on when:

- Windshield wipers are operating at a high speed.
- The camera has detected a dense fog.

# Wipers and Washers

## Windshield Wiper/Washer

### ▼ Models with manual intermittent operation

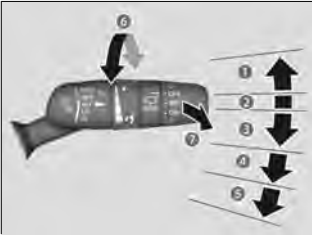

#### ❶ MIST

The wipers run at high speed until you release the lever.

#### ❷ OFF

#### ❸ INT

Low speed with intermittent

#### ❹ LO

Low speed wipe

#### ❺ HI

High speed wipe

#### ❻ Intermittent Time Adjustment Ring

Turn the adjustment ring to adjust the wiper operation.

☒ : Lower speed, fewer sweeps

☒☒ : Higher speed, more sweeps

#### ❼ Pull to use washer

Sprays while you pull the lever toward you. When you release the lever for more than one second, the spray stops, the wipers sweep two or three more times to clear the windshield, and then stop.

- If the vehicle speeds up while the wipers are operating intermittently, the length of the wipe interval shortens.
- When the vehicle speeds up, the wiper operation's shortest delay setting (☒☒) and the **LO** setting become the same.

▼ **Models with automatic intermittent operation**

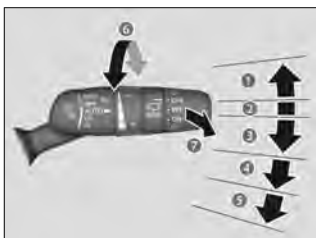

**1 MIST**

The wipers run at high speed until you release the lever.

**2 OFF**

**3 AUTO**

**4 LO**

Low speed wipe

**5 HI**

High speed wipe

**6 AUTO sensitivity adjustment**

You can adjust the sensitivity of the rainfall sensor.

-: Low Sensitivity

+: High Sensitivity

**7 Pull to use washer**

Sprays while you pull the lever toward you.

When you release the lever for more than one second, the spray stops, the wipers sweep two or three more times to clear the windshield, and then stop.

▼ **All models**

**!** When lifting the front wiper arms, move them into the maintenance position before lifting them.

**Q** [Lifting the Front Wiper Arms](#) ▶ P.376

**!** Do not use the wipers when the windshield is dry. The windshield will get scratched, or the rubber blades will get damaged.

**!** Turn the washers off if no washer fluid comes out. The pump may get damaged.

## Automatic Intermittent Wipers\*



When you push the lever down to **AUTO**, the windshield wipers sweep once, and enter the automatic mode.

The wipers operate intermittently, at low speed, or at high speed and stop in accordance with the amount of rainfall the rainfall sensor detects.

» If the sensor reacts to something other than rain and the wipers operate unnecessarily, you can stop them by moving the lever to the **OFF** position.

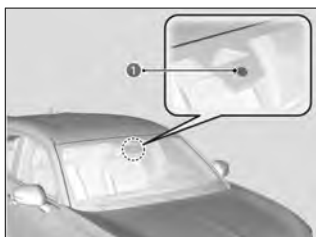

The rainfall sensor is in the location as shown.

### 1 Rainfall Sensor

**AUTO** should always be turned **OFF** before the following situations in order to prevent severe damage to the wiper system:

- Cleaning the windshield
- Driving through a car wash
- No rain present

## Rear Wiper/Washer



- 1 **OFF**
- 2 **INT** (Intermittent)
- 3 **ON** (Continuous wipe)
- 4 **Washer**

Sprays while you rotate the switch to this position. Hold it to activate the rear wiper and to spray the washer.

Once released, the washer spray will stop and the rear wiper will return to its selected switch setting after a few sweeps.

\*: Not available on all models

- When you change the transmission to **R** with the windshield wipers activated, the rear wiper operates automatically even if its switch is off.

## What to Do If

### When the wipers are not moving

The wiper motor may stop motor operation temporarily to prevent an overload. Wiper operation will return to normal within a few minutes.

### When the wiper blades are stuck to the windshield glass due to freezing in cold weather

In cold weather, the blades may freeze to the windshield.

Operating the wipers in this condition may damage the wipers. Use the defogger or heated windshield\* to warm the windshield, then turn the wipers on.

### When snow has accumulated on the wipers

If the wipers stop operating due to an obstacle such as the buildup of snow, park the vehicle in a safe place.

Rotate the wiper switch to **OFF**, set the power mode to ACCESSORY or VEHICLE OFF, then remove the obstacle.

\*: Not available on all models

# Defroster

## Defrosting the Windshield and Windows

### When defogging the front or side windows

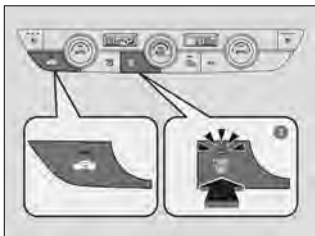

Pressing the button (1) turns the air conditioning system on and automatically switches the system to fresh air mode.

Press the button (1) again to turn off, and the system returns to the previous settings.

### Rear Defogger/Heated Door Mirror Button

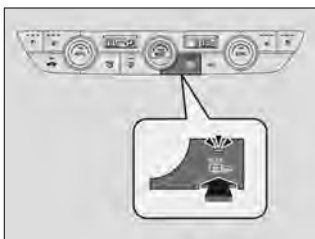

Press the rear defogger and heated door mirror button to defog the rear window and mirrors when the power mode is in ON.

- The rear defogger and heated door mirror automatically switch off after 10-30 minutes depending on the outside temperature. However, if the outside temperature is 32°F (0°C) or below, it does not automatically switch off.
- When the power mode is set to ON and the outside temperature is below 41°F (5°C), the heated door mirror may automatically activate for 10 minutes.
- If you press the  button during Auto Idle Stop, the engine restarts automatically.

**!** For your safety, make sure you have a clear view through all the windows before driving.

**!** After defrosting the windows, switch over to fresh air mode. If you keep the system in recirculation mode, the windows may fog up from humidity. This impedes visibility.

! Do not set the temperature near the lower limit.  
When cold air hits the windshield, the outside of the windshield may fog up.

! This system consumes a lot of power, so turn it off when the window has been demisted.  
This may weaken the battery, making it difficult to start the engine.

## What to Do If

### To rapidly defrost the windows

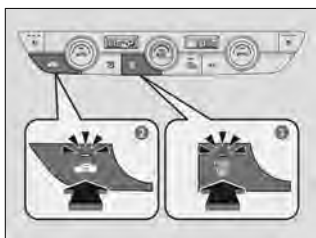

- [1] Press the button (1).
- [2] Press the button (2). The indicator turns on.

### When the side window gets fogged up

Adjust the nearest climate control vent so that it blows directly on the side window.

# Heated Windshield Button\*

## Heated Windshield Button



Press the heated windshield button to deice the windshield at the wiper park area when the power mode is in ON.

The heated windshield will automatically switch off after 15 minutes.

### 1 Heated Windshield Button

**!** This system consumes a lot of power, so turn it off when the window has been deiced. Also, do not use the system for a long period when the engine is idling. This may weaken the 12-volt battery, making it difficult to start the engine.

\*: Not available on all models



# Driving Features

## Acura Integrated Dynamics System

Modifies the dynamic character of the vehicle. There are four or five modes to select from: **INDIVIDUAL\***, **SPORT**, **NORMAL**, **COMFORT**, or **SNOW**.

### Selecting the Dynamic Mode

Press the **Dynamic Mode** switch (1) or **INDIVIDUAL** button\* (2) to select a mode. The mode you have selected appears on the driver information interface and audio/information display.

Press and hold the **INDIVIDUAL** button\*, the mode switches to the **INDIVIDUAL** settings.

 Customizing the INDIVIDUAL Settings\* ▶P.153

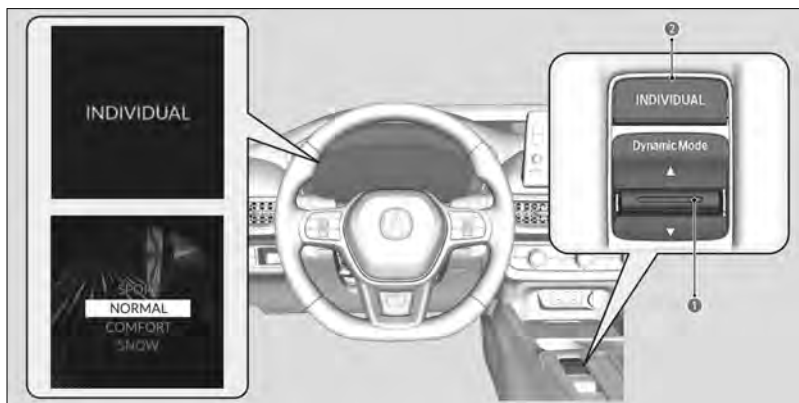

The mode may not be able to be changed under some driving conditions. If there is a vehicle system failure, a message will also appear on the gauge, and you cannot change the mode.

### INDIVIDUAL Mode\*

Customize each category to suit the driver's preference.

 Customizing the INDIVIDUAL Settings\* ▶P.153

### SPORT Mode

Enhances vehicle response through increased steering effort, heightened throttle response, improved active sound control, and more responsive ride and handling.

\*: Not available on all models

- » When in **SPORT** mode, the Auto Idle Stop System will stay disabled regardless of the Auto Idle Stop **OFF** button.

 Auto Idle Stop ▶ P.154

## **NORMAL Mode**

Optimizes the balance between operability and comfort.

## **COMFORT Mode**

Enhances driver comfort.

## **SNOW Mode**

Maximizes controllability on snowy roads through powertrain settings.

- » While in **SNOW** mode, the Auto Idle Stop System will stay disabled regardless of the Auto Idle Stop **OFF** button.

 Auto Idle Stop ▶ P.154



**SNOW** mode does not allow you to drive on snowy or frozen roads in all situations. There are limits to **SNOW** mode.

When driving on snowy or frozen roads, mount winter tires, reduce speed, and maintain sufficient distance between vehicles.

 Winter Tires ▶ P.385

## **Next Start-Up Mode When the Engine Has Restarted**

The mode for the next start-up is saved according to the following chart. Each keyless remote has its own mode saved.

Last Dynamic Mode	Next Dynamic Mode
<b>NORMAL</b>	<b>NORMAL</b>
<b>COMFORT</b>	<b>COMFORT</b>
<b>SPORT</b> , or <b>INDIVIDUAL*</b> (via <b>NORMAL</b> or <b>SPORT</b> )	<b>NORMAL</b>
<b>INDIVIDUAL*</b> (via <b>COMFORT</b> )	<b>COMFORT</b>

## **Customizing the INDIVIDUAL Settings\***

You can customize the **INDIVIDUAL** settings linked to your current keyless remote.

- [1] Press and hold the **INDIVIDUAL** button or select **Customize** to enter **INDIVIDUAL** mode and open the **INDIVIDUAL** settings.
- [2] Select the setting category.

\*: Not available on all models

[3] Select the desired setting.

» You can also customize from **Vehicle Settings** on the audio/information screen.

 Customized Features ▶ P.249



Category	Description
<b>Engine</b>	Select <b>COMFORT</b> , <b>NORMAL</b> , or <b>SPORT</b> for the engine throttle response and transmission shift response.
<b>Steering</b>	Select <b>COMFORT</b> , <b>NORMAL</b> , or <b>SPORT</b> for the steering effort.
<b>Engine Sound</b>	Select <b>COMFORT</b> , <b>NORMAL</b> , or <b>SPORT</b> for the engine sound.
<b>Idle Stop</b>	Set the Auto Idle Stop system to <b>Enable</b> or <b>Disable</b> . While <b>Idle Stop</b> is <b>Disable</b> in <b>INDIVIDUAL</b> mode, the Auto Idle Stop System will stay disabled regardless of the Auto Idle Stop <b>OFF</b> button.  Auto Idle Stop ▶ P.154
<b>Gauge</b>	Select <b>COMFORT</b> , <b>NORMAL</b> , or <b>SPORT</b> to set the gauges to be displayed.

When you select **Reset to Default** on the **INDIVIDUAL Settings** screen, all **INDIVIDUAL** settings are reset to their factory defaults.

## Auto Idle Stop

To help maximize fuel economy, the engine automatically stops when the vehicle comes to a stop, depending on environmental and vehicle operating conditions. The indicator (green) comes on at this time.



### 1 Auto Idle Stop Indicator (Green)

The environmental and vehicle conditions that impact Auto Idle Stop system operation are varied.

Q Auto Idle Stop Activates When: ▶P.156

The engine then restarts once the vehicle is about to move again, and the indicator (green) goes off.

Q The Engine Automatically Restarts When:  
▶P.157

If the driver's door is opened while the indicator (green) comes on, a buzzer sounds to notify you that the Auto Idle Stop function is in operation.

A message associated with Auto Idle Stop appears on the driver information interface.



The Auto Idle Stop suspend indicator (1) comes on and a message appears on the driver information interface when the Auto Idle Stop system cannot be activated.

Q Indicator List ▶P.335

Q Auto Idle Stop System ON/OFF ▶P.156

- The 12-volt battery installed in this vehicle is specifically designed for a model with Auto Idle Stop. Using a 12-volt battery other than this specified type may shorten the 12-volt battery life, and prevent Auto Idle Stop from activating. If you need to replace the 12-volt battery, make sure to select the specified type. Ask a dealer for more details.
- If you are using an electronic device during Auto Idle Stop, the device may temporarily be turned off when the engine restarts.

## Auto Idle Stop System ON/OFF



To turn the Auto Idle Stop system off, press Auto Idle Stop **OFF** button (1). The Auto Idle Stop system stops.

» Auto Idle Stop system will stop, the Auto Idle Stop **OFF** indicator (2) will come on, and a message will appear on the driver information interface.

The Auto Idle Stop system is turned on every time you start the engine, even if you turned it off the last time you drove the vehicle.

- If you turn off the Auto Idle Stop system while it is activated, the engine will restart. If you press and hold the Auto Idle Stop **OFF** button, you can select whether or not to display the status messages.

## Auto Idle Stop Activates When:

The vehicle stops with the shift lever in **D** and the brake pedal depressed. When you put the transmission into **P** quickly while depressing the brake pedal, the Auto Idle Stop continues to operate, even if the brake pedal is released.

» If you move the shift lever slowly, the engine may automatically restart.

- Do not open the hood while the Auto Idle Stop function is activated. If the hood is opened, the engine will not restart automatically. In this case, restart the engine with the **ENGINE START/STOP** button.

**Q Starting the Engine ▶P.105**

- Pressing the **ENGINE START/STOP** button causes the engine to no longer restart automatically. Follow the standard procedure to start the engine.

**Q Starting the Engine ▶P.105**

- When ACC with Low Speed Follow is in operation, the vehicle stops without depressing the brake pedal and Auto Idle Stop may activate. In such cases, the engine may restart if you change the shift position other than **D**.

## Auto Idle Stop does not activate when:

- The Auto Idle Stop **OFF** button is pressed.
- The driver's seat belt is not fastened.
- The engine is not adequately warmed up or coolant temperature is high.
- The transmission fluid temperature is low or high.
- The vehicle comes to a stop again before the vehicle speed reaches 3 mph (5 km/h) after the engine starts.

- The vehicle is stopped on a steep incline.
- The transmission is in a position other than **D**.
- The engine is started with the hood open.
  - » Turn off the engine. Close the hood before you restart the engine to activate Auto Idle Stop.
- The 12-volt battery charge is low.
- The internal temperature of the 12-volt battery is 41 °F (5 °C) or less.
- The climate control system is in use, and the outside temperature is below -4 °F (-20 °C) or over 104 °F (40 °C).
- The climate control system is in use, and the temperature is set to **Hi** or **Lo**.
-  is on (indicator on).
- The Acura Integrated Dynamics System is in the **SPORT** mode or **SNOW** mode.

### Auto Idle Stop may not activate when:

- The vehicle is stopped by braking suddenly.
- The steering wheel is operated.
- The vehicle is repeatedly accelerated and decelerated at a low speed.
- The fan speed is high.
- The climate control system is in use, and there is a significant difference between the set temperature and the actual interior temperature.
- The climate control system is in use, and humidity in the interior is high.

### The Engine Automatically Restarts When:

- The brake pedal is released (without the automatic brake hold system activated).
- The accelerator pedal is depressed (with the automatic brake hold system activated).

 Automatic Brake Hold ▶ P.116

- When the transmission is put into **P** from **D** or **N** on a slope.

### The engine restarts even if the brake pedal is depressed\*1 when:

- The Auto Idle Stop **OFF** button is pressed.
- The steering wheel is operated.
- The transmission is put into **R** or **S**, or when it is set from **N** to **D**.
  - » If you put the transmission into **P** after the Auto Idle Stop activates, the Auto Idle Stop continues to operate. In this case, the engine restarts when you depress the brake pedal.
- The pressure on the brake pedal is reduced and the vehicle starts moving while stopped on an incline.
- The brake pedal is released slightly during a stop.
- The 12-volt battery charge becomes low.
- The accelerator pedal is depressed.
- The driver's seat belt is unlatched.
-  is ON (indicator on).

- The climate control system is in use, and the difference between the set temperature and actual interior temperature becomes significant.
- The climate control system is being used to dehumidify the interior.
- The Acura Integrated Dynamics System mode is changed to **SPORT** mode or **SNOW** mode.
- The vehicle ahead of you starts again when your vehicle stops automatically with ACC with Low Speed Follow.

\*1: With the automatic brake hold system activated, you can release the brake pedal while Auto Idle Stop is in operation. If the automatic brake hold system has been turned off, or if there is a problem with the system, the engine will restart automatically when you release the brake pedal.

 Automatic Brake Hold  P.116

## Starting Assist Brake Function

Briefly keeps the brake applied after releasing the brake pedal to restart the engine. This can keep your vehicle from unexpectedly moving while on an incline.

## Hill Descent Control System

When driving down hills where engine braking is not enough to decelerate the vehicle, this system helps maintain a constant vehicle speed without needing to depress the brake pedal.

The system operates under the following conditions.

- Driving at a speed between about 2-12 mph (3-20 km/h).
- Driving downhill.
- Accelerator pedal and brake pedal are not depressed.

### **WARNING**

Hill Descent Control cannot maintain a constant vehicle speed in every situation.

When driving down a very steep hill or on slippery road surfaces, the vehicle may not be able to maintain the vehicle speed and could cause a crash, resulting in serious injury or death.

Since Hill Descent Control is not designed to increase the limits of vehicle performance, the driver must always be aware of road surface conditions and drive safely.

## How to Activate the System

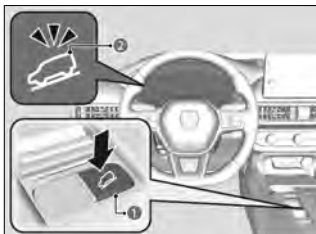

When the vehicle speed is less than about 12 mph (20 km/h), press the  button (1) to turn the system on.

» The system goes into standby mode, and the Hill Descent Control System indicator (white) (2) comes on.

When all the working conditions are met, the system activates, and the vehicle begins to maintain the vehicle speed when driving downhill.

» The Hill Descent Control System indicator (green) comes on when operating.

## Gauge display



### 1 The system's operating status

Green: Activated

White: Standby

### 2 Vehicle speed display

White: Set speed

Gray: Current speed

» Blinks when the vehicle speed is above the operating speed.

### 3 Current Speed

### 4 Operating Range of Set Speed.

- Using the system repeatedly for a long time may cause the brakes to heat up and make the system go into standby mode temporarily.
- The pedals may vibrate or you may hear the system working when in operation.
- The brake lights automatically come on while the system is in operation.

## To Adjust the Set Speed

Depress the accelerator pedal or brake pedal to adjust the vehicle speed within the operating range. The vehicle speed at which you release the accelerator pedal or brake pedal will be the set speed.

## To Cancel

Press the  button to turn the system off.



## Vehicle Stability Assist™ (VSA®), aka Electronic Stability Control (ESC), System

VSA® helps stabilize the vehicle during cornering if the vehicle turns more or less than what was intended. It also assists in maintaining traction on slippery surfaces. It does so by regulating engine output and selectively applying the brakes.

- To restore VSA® functionality/features, press the  (VSA® **OFF**) button until you hear a beep.
- VSA® is turned on every time you start the engine, even if you turned it off the last time you drove the vehicle.
- The main function of the VSA® system is generally known as Electronic Stability Control (ESC). The system also includes a traction control function.
- In certain unusual conditions when your vehicle gets stuck in shallow mud or fresh snow, it may be easier to free it with the VSA® temporarily switched off.

**!** VSA® cannot enhance stability in all driving situations and does not control the entire braking system. You still need to drive and corner at speeds appropriate for the conditions and always leave a sufficient margin of safety.

**!** The VSA® may not function properly if tire type and size are mixed. Make sure to use the same size and type of tire, and the air pressures as specified.

### VSA® Operation



When VSA® activates, the VSA® system indicator **1** will also blink.

- » The engine and motor do not respond to the accelerator.
- » You may also notice some noise from the hydraulic brake system.

**!** When the VSA® system indicator comes on and stays on while driving, there may be a problem with the system. While this may not interfere with normal driving, have your vehicle checked by a dealer immediately.

## VSA® On and Off



### 1 VSA® OFF Indicator

To partially disable VSA® functionality/features, press and hold  (VSA® OFF) button (2) until you hear a beep.

» Your vehicle will have normal braking and cornering ability, but traction control function will be less effective.

To restore VSA® functionality/features, press the button until you hear a beep.

VSA® is turned on every time you start the engine, even if you turned it off the last time you drove the vehicle.

**!** You should only attempt to free your vehicle with the VSA® off if you are not able to free your vehicle from being stuck in shallow mud, fresh snow, etc. with the VSA® on. Immediately after freeing your vehicle, be sure to switch VSA® on again. We do not recommend driving your vehicle with the VSA® system switched off.

## Agile Handling Assist

Lightly brakes each of the front and rear wheels, as needed, when you turn the steering wheel, and helps support the vehicle's stability and performance during cornering.

- When the VSA® system indicator comes on and stays on while driving, the agile handling assist does not activate.

**!** The agile handling assist cannot enhance stability in all driving situations. You still need to drive and corner at speeds appropriate for the conditions and always leave a sufficient margin of safety.

## All-Wheel Drive (AWD) with Intelligent Control System\*

This vehicle is equipped with AWD which transfers power to all four wheels. AWD distributes driving force between the front and rear wheels in accordance with the driving conditions, enabling stable driving.

Maintain sufficient distance between vehicles when driving on slippery roads.

\*: Not available on all models

If you excessively spin all four wheels and overheat the AWD system, only the front wheels receive power. Stop until the system cools down.

**!** Do not continuously spin the front tires of your vehicle. Continuously spinning the front tires can cause transmission or rear differential damage.

**!** The AWD may not function properly if tire type and size are mixed. Make sure to use the same size and type of tire, and the air pressures as specified.

**Q** Tire and Wheel Replacement ▶P.384

## Tire Pressure Monitoring System (TPMS) with Tire Fill Assist



Monitors the tire pressure while you are driving. If your vehicle's tire pressure becomes significantly low, the Low Tire Pressure/TPMS indicator (1) comes on and a **Tire pressures low** message appears.

- Conditions such as low ambient temperature and altitude change directly affect tire pressure and can trigger the low tire pressure/TPMS indicator to come on.

**Q** When Indicators Come On/Blink ▶P.337

- Tires can become under-inflated in colder weather.
- Tires can become over-inflated in warmer weather.
- The low tire pressure/TPMS indicator will not come on as a result of over-inflation.
- Only use genuine wheels equipped with TPMS since your vehicle's wheels are equipped with the low tire pressure/TPMS sensor.

If you drive your vehicle without the genuine wheels equipped with TPMS, the low tire pressure/TPMS indicator blinks for one minute and then stays on.

**Q** Tire and Wheel Replacement ▶P.384

- The TPMS can audibly and visually inform you of changes in tire pressure of the individual tire that you are adjusting.

**Q** Tire Fill Assist ▶P.379

- **Tire pressure monitor system problem. Check tire pressure. See your dealer.** may appear if you drive with a tire not equipped with a TPMS sensor (including the compact spare tire), or there is a problem with the TPMS.
- The pressure displayed on the driver information interface can be slightly different from the actual pressure as measured by a gauge. If there is a significant difference between the two values, or if the Low Tire Pressure/TPMS indicator and the message on the driver information interface do not go off after you have inflated the tire to the specified pressure, have the system checked by a dealer.

## Tire Pressure Monitor



To select the tire pressure monitor, set the power mode to ON, and roll the right selector wheel until you see the tire pressure screen.

» The pressure for each tire is displayed in psi.

 Switching the Display ▶ P.346

## Tire Pressure Monitoring System (TPMS) - Required Federal Explanation

Each tire, including the spare (if provided), should be checked monthly when cold and inflated to the inflation pressure recommended by the vehicle manufacturer on the vehicle placard or tire inflation pressure label.

(If your vehicle has tires of a different size than the size indicated on the vehicle placard or tire inflation pressure label, you should determine the proper tire inflation pressure for those tires.)

As an added safety feature, your vehicle has been equipped with a tire pressure monitoring system (TPMS) that illuminates a low tire pressure telltale when one or more of your tires is significantly under-inflated.



\*: Not available on all models

Accordingly, when the low tire pressure telltale illuminates, you should stop and check your tires as soon as possible, and inflate them to the proper pressure.

Driving on a significantly under-inflated tire causes the tire to overheat and can lead to tire failure. Under-inflation also reduces fuel efficiency and tire tread life, and may affect the vehicle's handling and stopping ability.

Please note that the TPMS is not a substitute for proper tire maintenance, and it is the driver's responsibility to maintain correct tire pressure, even if under-inflation has not reached the level to trigger illumination of the TPMS low tire pressure telltale.

Your vehicle has also been equipped with a TPMS malfunction indicator to indicate when the system is not operating properly. The TPMS malfunction indicator is combined with the low tire pressure telltale.

When the system detects a malfunction, the telltale will flash for approximately one minute and then remain continuously illuminated.

This sequence will continue upon subsequent vehicle start-ups as long as the malfunction exists.

When the malfunction indicator is illuminated, the system may not be able to detect or signal low tire pressure as intended.

TPMS malfunctions may occur for a variety of reasons, including the installation of replacement or alternate tires or wheels on the vehicle that prevent the TPMS from functioning properly.

Always check the TPMS malfunction telltale after replacing one or more tires or wheels on your vehicle to ensure that the replacement or alternate tires and wheels allow the TPMS to continue to function properly.

## Interior Lights

Interior Light Switches	167
Map Light Switches	168

## Interior Convenience Items

Glove Box	169
Center Console Box	169
Accessory Power Sockets	169
Wireless Charger	170
Coat Hook	173
Tie-down Anchors	173
Sunglasses Holder	174
Cargo Area Cover*	174
Beverage Holders	175
Under-Floor Storage Area	176

## Front Seat Heaters/Ventilators\*

Using the Front Seat Heaters/Ventilators	177
--	-----

## Heated Steering Wheel\*

Using Heated Steering Wheel	179
-----------------------------	-----

## Moonroof\*/Panoramic Roof\*

Opening/Closing the Moonroof	180
Opening/Closing the Panoramic Roof	181
What to Do If	183

## Climate Control System

Automatic Climate Control System	184
Using Automatic Climate Control	185

## In-Vehicle Infotainment

About Your In-Vehicle Infotainment	188
Audio System Basic Operation	188
USB Ports	192
Audio Remote Controls	193
Connecting a Device	194
About System Updates*	197

## 9" Color Touchscreen

Start Up	199
Reboot Audio	199
Adjusting the Clock	199
Adjusting the Sound	200

\*: Not available on all models

Changing the Display Setting	200
Playing AM/FM Radio	201
About Audio Playback	202
Apple CarPlay	206
Android Auto™	208
Bluetooth® HandsFreeLink®	209
Customized Features	214

## 9" Color Touchscreen with Google built-in

Start Up	218
Reboot Audio	219
Home Screen	219
System Updates	220
Trip Computer	222
Adjusting the Clock	222
Adjusting the Sound	223
Changing the Display Setting	223
Alexa Built-In	224
Playing AM/FM Radio	225
About Audio Playback	227
AcuraLink®	231
AcuraLink® Service	232
Wi-Fi Connection	232
AT&T Hotspot	233
Apple CarPlay	234
Android Auto™	237
Google built-in	240
User Information	242
Bluetooth® HandsFreeLink®	244
Customized Features	249

## General Information on the Audio System

Compatible iPod, iPhone, and USB Flash Drives	259
Honda App License Agreement	260
About Open Source Licenses	271
License Information	272

# Controls

Legal Information on Apple CarPlay/Android Auto .....	274
--	-----

# Interior Lights

## Interior Light Switches

### Front



### 1 : ON

The interior lights come on regardless of whether the doors are open or closed.

### 2 : OFF

The interior lights remain off regardless of whether the doors are open or closed.

### 3 : Door activated

The interior lights come on in the following situations:

- When any doors are opened
- When the driver's door is unlocked
- When the power mode is set to VEHICLE OFF

### Rear



- In the door activated position, the interior lights turn off about 30 seconds after the doors are closed. When you unlock the driver's door but do not open it, the lights turn off after about 30 seconds.
- If you leave any of the doors open in VEHICLE OFF mode, the interior lights go off after about 15 minutes.



You can change the interior lights dimming time.

#### ▼ Models with 9" Color Touchscreen

[Q Vehicle Settings\\*](#) ▶ P.352

#### ▼ Models with 9" Color Touchscreen with Google built-in

[Q Customized Features](#) ▶ P.249



To avoid draining the 12-volt battery, do not leave the interior light on for an extended length of time when the engine is off.



## Map Light Switches

This light is used for situations such as viewing a map at night while your vehicle is stopped. Press the switch to turn on the light; press it again to turn off the light.

### Front Seat



The map lights can be turned on and off by pressing the buttons.

### Rear Seat



The map lights can be turned on and off by touching the map lights.

When the front interior light switch is in the door activated position and any door is open, the map light will not go off when you press the buttons or touch the map lights.

# Interior Convenience Items

## Glove Box



Pull the handle to open the glove box.

① Handle

### **⚠ WARNING**

An open glove box can cause serious injury to your passenger in a crash, even if the passenger is wearing the seat belt. Always keep the glove box closed while driving.

## Center Console Box



Pull the handle to open the console compartment.

① Handle

## Accessory Power Sockets

The accessory power socket can be used when the power mode is in ACCESSORY or ON. Open the cover to use it.

The accessory power socket is designed to supply power for 12-volt DC accessories that are rated 180 watts (15 amps) or less.

### Accessory power socket (front panel)



### Accessory power socket (cargo area)

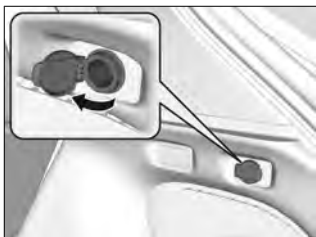

- ❗ Do not insert an automotive type cigarette lighter element. This can overheat the accessory power socket.

- ❗ To prevent 12-volt battery drain, only use the accessory power socket with the engine running.

- ❗ When the accessory power socket is not in use, close the cover to prevent any small foreign objects from getting into the accessory power socket.

## Wireless Charger

### About Wireless Charger

To use the wireless charger, the power mode must be in ACCESSORY or ON. Charge any devices compatible with Qi wireless charging on the area indicated by the  mark as follows:



- 1 (Power) Button
- 2 Green Indicator
- 3 Amber Indicator
- 4 Charging Area

- [1] To turn the system on and off, press and hold the (power) button.
  - » When the system is activated, the green indicator light comes on.
- [2] Place the device you want to charge on the charging area.
  - » The system will automatically start charging the device, and the amber indicator light will come on.
  - » Make sure that the device is compatible with the system, and placed with the chargeable side in the center of the charging area.
- [3] When charging is completed, the green indicator light will come on.
  - » Depending on the device, the amber indicator light will stay on.

### CAUTION

#### **Metal objects between the charge pad and the device to be charged will get hot and can burn you.**

- Always remove foreign objects from the charge pad before charging the device.
- Be sure the surface is clear of dust and other debris before charging.
- Do not spill liquids (e.g., water, drinks, etc.) on the charger and the device.
- Do not use oil, grease, alcohol, benzine, or thinner for cleaning the charge pad.
- Do not cover the system with towels, clothing, or other objects while charging etc.
- Avoid spraying aerosols which may come in contact with the charge pad surface.

- This system consumes a lot of power. Do not use the system for a long period of time when the engine is not running. This may weaken the 12-volt battery, making it difficult to start the engine.

- When using the wireless charger, check the user's manual that came with the compatible device you want to charge.

 Do not place any magnetic recording media or precision machines within the charge area while charging. The data on your cards such as credit cards can be lost because of the magnetic effect. Also, precision machines such as watches can be affected.

 Do not charge more than one device at a time on a charging area.

### **RF Radiation Exposure Statement:**

#### **▼ U.S. models**

This equipment complies with FCC RF Radiation exposure limits set forth for an uncontrolled environment.

This device and its antenna must not be co-located or operating in conjunction with any other antenna or transmitter.

#### **▼ Canadian models**

This equipment complies with ICSED RF Radiation exposure limits set forth for an uncontrolled environment.

This device and its antenna must not be co-located or operating in conjunction with any other antenna or transmitter.

“Qi” and  marks are the registered trademarks owned by Wireless Power Consortium (WPC).

The wireless charger can support up to 15 W, but the charging rate varies based on the device and other conditions.

 appears on the audio screen when the device is being charged by the wireless charger.

During the charging phase, it is normal for the charging area and the device to heat up.

Charging may be briefly interrupted when:

- All doors or the tailgate are closed to avoid interference with the proper functioning of the keyless access system.

In the following cases, charging may stop or not start:

- The device is already fully charged.
- The temperature of the device is extremely high while charging.
- You are at a place that emits strong electromagnetic waves or noises, such as a TV station, electric power plant, or gas station.
- The device has a cover, case, or accessories which are not compatible with wireless charging.

### **Indicator Flashing**

Perform one of the following solutions, based on the situation.

When the indicator (Green & Amber) blinks simultaneously

- » Remove the obstacle(s).
- » Pick up and reset the device to the center of the charging area where  is located.
- » Temporarily suspend charging the device. Wait for the temperature to drop and attempt to charge the device again.

When the indicator (Amber) is blinking

- » Contact a dealer for repairs.

## Coat Hook



There is a coat hook on the rear left grab handle.

The coat hook is not designed for large or heavy items.

## Tie-down Anchors



The tie-down anchors on the cargo area floor can be used to install a net for securing items.

### 1 Anchor

 Do not let anyone access items in the cargo area while driving. Loose items can cause injury if you have to brake hard.

## Sunglasses Holder



To open the sunglasses holder, press and release the indent.

To close, press it again until it latches.

You can store eyeglasses and other small items in this holder.

- !** Keep the holder closed while driving except when accessing stored items.

## Cargo Area Cover\*

The cargo area cover may be removed to give you more cargo room.

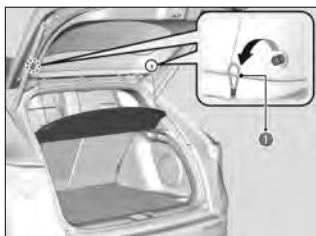

### To remove the cargo area cover

- [1] Open the tailgate.
- [2] Remove the straps on each side of the tailgate.

### 1 Straps



- [3] Pull the cargo area cover toward you until it disengages from the support latches.

Reverse this procedure to install the cargo area cover.

After reinstalling the cargo area cover, make sure it is latched securely.

### 1 Support Latches

Do not place items on the cargo area cover, or stack objects higher than the top of the back seat.

\*: Not available on all models

They could block your view and be thrown about the vehicle during a crush or sudden stop.

Do not apply excessive pressure to the cover, such as leaning on it to retrieve an item.

## Beverage Holders

Spilled liquids can damage the upholstery, carpeting, and electrical components in the interior.



### ■ Front seat beverage holders

Located in the console between the front seats.



### ■ Front door side beverage holders

Located in both front door side pockets.

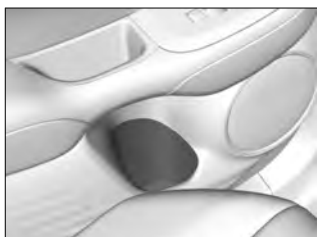

### ■ Rear door side beverage holders

Located in both rear door side pockets.



### Rear seat beverage holders



Fold the armrest down to use the rear seat beverage holders.

## Under-Floor Storage Area



Fold the cargo area floor lid into three parts.

### 1 Cargo Area Floor Lid



### 1 Under-Floor Storage Area

# Front Seat Heaters/Ventilators\*

## Using the Front Seat Heaters/Ventilators

The seat heaters or ventilators\* can be used when the power mode is in ON.

### ▼ Models without front seat ventilators

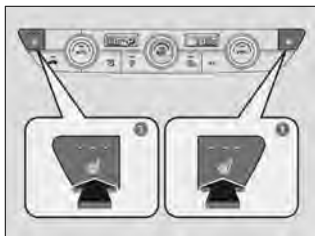

#### ① Seat Heater Button

Press the seat heater or the seat ventilator\* button:

Once - The HI setting (three indicators on)

Twice - The MID setting (two indicators on)

Three times - The LO setting (one indicator on)

Four times - The OFF setting (no indicators on)

### ▼ Models with front seat ventilators

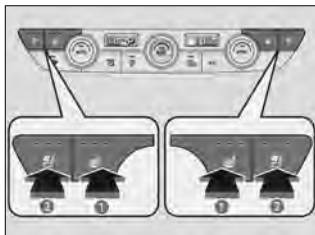

#### ① Seat Heater Button

#### ② Seat Ventilator Button

- When the power mode is turned on after it is turned off, the previous setting is maintained.
- After a certain period of time, the strength setting for the front seat heaters will automatically be reduced by one level at a time until the front seat heaters shut off. The elapsed time varies according to the interior environment.

#### Press the AUTO button:

- Both the air conditioner and seat temperature will automatically change to the setting most suitable to the ambient environment.
  - » When any seat heater or seat ventilation button is pressed, settings will switch to manual mode.
- As time passes, the set temperature will fall, and eventually the seat heater will shut off.

\*: Not available on all models

- The seat heater and seat ventilation may turn on if sensors detect weight on the passenger seat due to luggage, etc.



To prevent automatic activation, you can turn off automatic climate control for the front seat.

▼ **Models with 9" Color Touchscreen**

🔍 Vehicle Settings\* ▶ P.352

▼ **Models with 9" Color Touchscreen with Google built-in**

🔍 Customized Features ▶ P.249

## **WARNING**

Heat induced burns are possible when using seat heaters.

Persons with a diminished ability to sense temperature (e.g., persons with diabetes, lowerlimb nerve damage, or paralysis) or with sensitive skin should not use seat heaters.



Do not use the seat heaters even in LO when the engine is off. Under such conditions, the 12-volt battery may be weakened, making the engine difficult to start.

# Heated Steering Wheel\*

## Using Heated Steering Wheel



### 1 Heated Steering Wheel Button

The heated steering wheel can be used when the power mode is in ON.

Press the button on the lower side of the steering wheel.

When a comfortable temperature is reached, press the button again to turn it off.

The heated steering wheel is turned off every time you start the engine, even if you turned it on the last time you drove the vehicle.

- !** Do not use the heated steering wheel continuously when the engine is off. Under such conditions, the 12-volt battery may be weakened, making the engine difficult to start.

\*: Not available on all models

# Moonroof\*/Panoramic Roof\*

## Opening/Closing the Moonroof

You can operate the moonroof when the power mode is in ON. Use the switch in the front of the ceiling to open and close the moonroof.



- 1 Open
- 2 Close
- 3 Tilt

### Automatic operation

**To open:** Pull the switch back firmly.

**To close:** Push the switch forward firmly.

The moonroof automatically open or close all the way. To stop the moonroof midway, pull or push the switch briefly.

### Manual operation

**To open:** Pull the switch back lightly, and hold it until the desired position is reached.

**To close:** Push the switch forward lightly, and hold it until the desired position is reached.

### Tilting the moonroof up

**To tilt:** Push on the center of the moonroof switch.

**To close:** Push the switch forward firmly, then release.

## ⚠ WARNING

Opening or closing the moonroof on someone's hands or fingers can cause serious injury.

Make sure all hands and fingers are clear of the moonroof before opening or closing it.

! Opening the moonroof in below freezing temperature or when it is covered with snow or ice can damage the moonroof panel or motor.

- The moonroof can be operated for up to 10 minutes after you set the power mode to OFF. Opening either front door cancels this function.

\*: Not available on all models

- When resistance is detected, the auto reverse function causes the moonroof to change directions, then stop. Auto reverse stops sensing when the moonroof is almost closed to ensure that it fully closes.

Make sure that all objects, including fingers, are clear of the moonroof.

You can use the remote transmitter to operate the moonroof.

🔍 Opening the Windows with the Remote ▶ P.88

## Opening/Closing the Panoramic Roof

### Using the Panoramic Roof Switch

You can operate the panoramic roof and sunshade when the power mode is in ON. Use the switch in the front of the ceiling to open and close the panoramic roof.



- 1 Open
- 2 Close
- 3 Tilt

#### Automatic operation

**To open:** Pull the switch back firmly.

**To close:** Push the switch forward firmly.

The panoramic roof automatically open or close all the way. To stop the panoramic roof midway, pull or push the switch briefly.

#### Manual operation

**To open:** Pull the switch back lightly, and hold it until the desired position is reached.

**To close:** Push the switch forward lightly, and hold it until the desired position is reached.

#### Tilting the panoramic roof up

**To tilt:** Push on the center of the panoramic roof switch.

» The sunshades will open automatically and the panoramic roof will start to tilt up.

**To close:** Push the switch forward firmly.

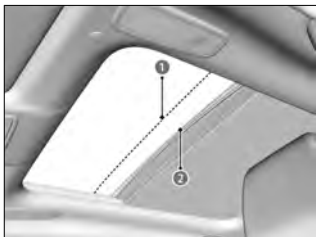

- 1 Comfort Position
- 2 Full Open Position

The panoramic roof cannot be fully opened in a single operation. The panoramic roof has a “comfort” position or wind noise reduction position at which the roof first stops. To open fully, pull the switch back again after the roof has stopped at this position.

Whenever the panoramic roof is opening, the sunshade moves along with it. However, when the panoramic roof is closing, the sunshade does not move.

When you tilt open the panoramic roof, the sunshade opens slightly to let in fresh air. When you close the panoramic roof from this position, the sunshade returns to its closed position.

### **⚠ WARNING**

Opening or closing the panoramic roof and sunshade on someone’s hands or fingers can cause serious injury.

Make sure all hands and fingers are clear of the panoramic roof and sunshade before opening or closing it.

- ❗ Opening the panoramic roof in below freezing temperature or when it is covered with snow or ice can damage the panoramic roof panel or motor.

- The panoramic roof can be operated for up to 10 minutes after you set the power mode to OFF. Opening either front door cancels this function.
- When resistance is detected, the auto reverse function causes the panoramic roof to change directions, then stop. Auto reverse stops sensing when the panoramic roof is almost closed to ensure that it fully closes.  
Make sure that all objects, including fingers, are clear of the panoramic roof.

You can use the remote transmitter to operate the panoramic roof.

**🔍 Opening the Windows with the Remote ▶ P.88**

## Using the Sunshade Switch



- 1 Open
- 2 Close

### Automatic operation

**To open:** Pull the switch back firmly.

**To close:** Push the switch forward firmly.

The sunshade automatically opens or closes all the way.

To stop the sunshade midway, pull or push the switch briefly.

### Manual operation

**To open:** Pull the switch back lightly, and hold it until the desired position is reached.

**To close:** Push the switch forward lightly, and hold it until the desired position is reached.

The sunshade can be opened or closed to adjust the amount of light that enters the cabin.

When you use the sunshade switch to open the sunshade, the panoramic roof does not move.

The sunshade cannot be fully closed if the panoramic roof is open. When you close the sunshade with the panoramic roof opened, the sunshade stops slightly before the panoramic roof glass. When you push the switch forward again, the sunshade and the panoramic roof close together.

## What to Do If

### When the moonroof/panoramic roof does not close

The moonroof/panoramic roof may get stuck if the auto reverse function activates in response to an object preventing it from closing.

If this happens, lightly press and hold the switch in the closing direction for about 15 seconds to release the auto reverse function.

Continue holding the switch until the panoramic roof closes completely.

After taking these steps, have your vehicle checked by a dealer.



# Climate Control System

## Automatic Climate Control System

### About Automatic Climate Control System

#### Explanations of Switches

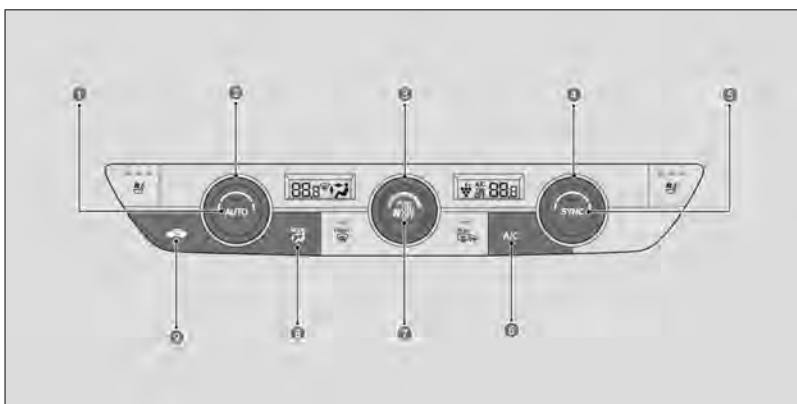

#### 1 AUTO Button

Switch to automatic control.

#### 2 Driver's Side Temperature Control Dial

Adjusts the driver's side interior temperature.

#### 3 Fan Control Dial

Adjusts the fan speed.

#### 4 Passenger's Side Temperature Control Dial

Adjusts the passenger's side interior temperature.

#### 5 SYNC (Synchronization) Button

Synchronize the temperature for the driver's side and the passenger's side.





#### 6 A/C (Air Conditioning) Button

Switch ON/OFF of cooling/dehumidification function.

#### 7 ON/OFF (ON/OFF) Button

Switch ON/OFF of the climate control system.

#### 8 MODE Control Button

-  Dashboard vents and back of the center console
-  Floor vents
-  Dashboard and floor vents, and back of the center console
-  Floor and defroster vents

**9**  **(Recirculation) Button**

Switch Recirculation mode/Fresh air mode.

- Recirculation (indicator light on):  
Recirculates air from the vehicle's interior through the system.
- Fresh air (indicator light off):  
Maintains outside ventilation. Keep the system in fresh air mode in normal situations.

## Using Automatic Climate Control

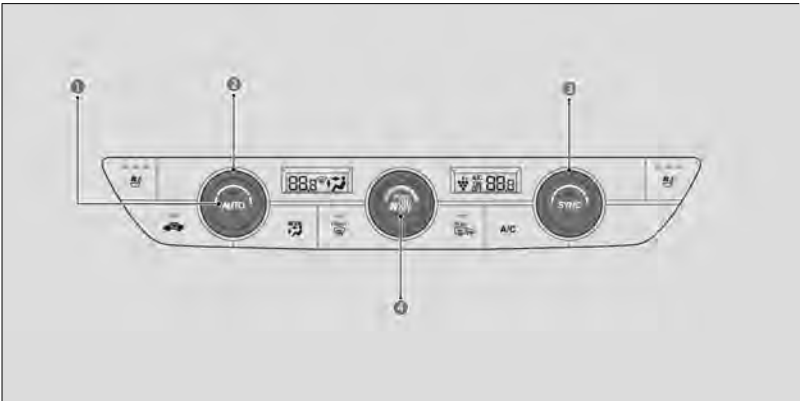

- 1** **AUTO** Button
- 2** **Driver's Side Temperature Control Dial**
- 3** **Passenger's Side Temperature Control Dial**
- 4**  **(ON/OFF) Button**

The automatic climate control system maintains the interior temperature you select. The system also selects the proper mix of heated or cooled air that raises or lowers the interior temperature to your preference as quickly as possible.

Use the system when the engine is running.

- [1] Press the **AUTO** button.
- [2] Adjust the interior temperature using the driver's side or passenger's side temperature control dial.
- [3] Press the  (ON/OFF) button to cancel.

- If any buttons are pressed while using the climate control system in auto, the function of the button that was pressed will take priority. The **AUTO** button indicator will go off, but functions unrelated to the button that was pressed will be controlled automatically.
- To prevent cold air from blowing in from outside, the fan may not start immediately when the **AUTO** button is pressed.
- For directions on the proper handling of the front seat heaters and seat ventilation, refer to the following page.

 Using the Front Seat Heaters/Ventilators ▶ P.177

 If the interior is very warm, you can cool it down more rapidly by partially opening the windows, turning the system on auto, and setting the temperature to low. Change the fresh air mode to recirculation mode until the temperature cools down.

## Synchronization Mode

You can set the temperature synchronously for the driver's side and the passenger's side in synchronization mode.

### SYNC on and off

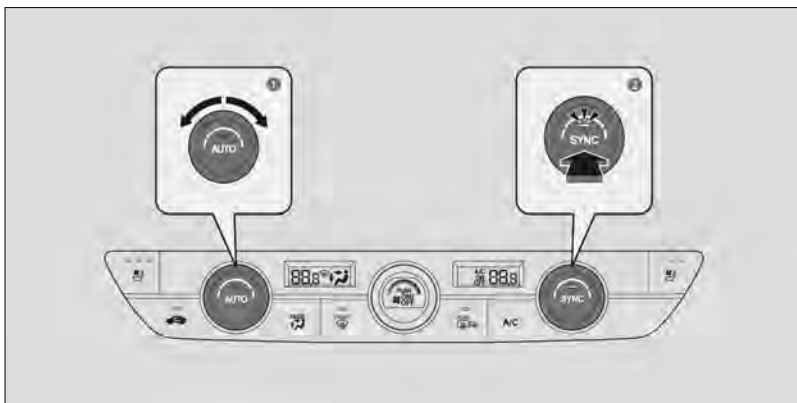

#### 1 Driver's Side Temperature Control Dial

#### 2 SYNC Button

- [1] Press the **SYNC** button.
    - » The system switches to synchronization mode.
  - [2] Adjust the temperature using the driver's side temperature control dial.
- Press the **SYNC** button or adjust the interior temperature using the passenger's side temperature control dial to return to dual mode.

- When you press the  button, the system changes to synchronization mode.
- When the system is in dual mode, the driver's side temperature and the passenger's side temperature can be set separately.

## Automatic Climate Control Sensors

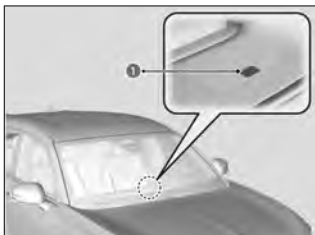

The automatic climate control system is equipped with sensors. Do not cover or spill any liquid on them.

1 Sensor

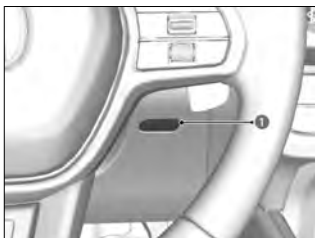

1 Sensor

# In-Vehicle Infotainment

## About Your In-Vehicle Infotainment

The audio system features AM/FM radio. It can also play USB flash drives, iPod, iPhone, smartphone, and *Bluetooth*® devices.

You can operate the audio system from the buttons and switches on the panel, the remote controls on the steering wheel, or the icons on the touchscreen interface.

» To use this system, the power mode must be in ACCESSORY or ON.

## Audio System Theft Protection

The audio system is disabled when it is disconnected from the power source, such as when the 12-volt battery is disconnected or goes dead. In certain conditions, the system may display a code entry screen. If this occurs, reactivate the audio system.

### Reactivating the audio system

- [1] Set the power mode to ON.
- [2] Turn on the audio system.
- [3] Press and hold the **VOL** /  **AUDIO**(volume/power) knob for more than two seconds.
  - » The audio system is reactivated when the audio control unit establishes a connection with the vehicle control unit. If the control unit fails to recognize the audio unit, you must go to a dealer and have the audio unit checked.

## Audio System Basic Operation

### Audio System Basic Operation with 9" Color Touchscreen

Use the **Audio Source** icon to access some audio functions.

Press the  (Home) button to go directly back to the home screen.



- 1 VOL / AUDIO (Volume/Power) Knob
- 2 (Connect) Button
- 3 (Home) Button
- 4 Audio Source Icon
- 5 Audio Function Operation Area
- 6 Status Bar
- 7 Apple CarPlay Icon
- 8 General Settings Icon
- 9 Android Auto Icon
- 10 Phone Function Operation Area

### Touchscreen operation

- Use simple gestures - including touching, swiping, and scrolling - to operate certain audio functions.
- Some functions may be limited while driving.
- Some items may be grayed-out during driving to reduce the potential for distraction. You can select them when the vehicle is stopped.
- Wearing gloves may limit or prevent touchscreen response.



You can change the touchscreen sensitivity setting.

[How to Customize the General Settings](#) ▶ P.215

### Selecting an audio source

Select **Audio Source** icon on the home screen, then select an icon on the source list to switch the audio source.

### Status bar





Displays information about your vehicle, connected devices, or etc. You can select the status bar to view more details in the status area.

## Audio System Basic Operation with 9" Color Touchscreen with Google built-in

Swiping the screen left or right changes to the next screen.

Press the  (Home) button to go directly back to the first page of the home screen from any page.



- 1  (Home) Button
- 2 Mode Change Switch Bar
- 3 Audio Source Icon
- 4 Status Bar
- 5 App Icons
- 6 Swipe
- 7  /  (SKIP/SEEK) Button
- 8 VOL/  AUDIO (Volume/Power) Knob
- 9  (Back) Button

### Touchscreen operation

- Use simple gestures - including touching, swiping, and scrolling - to operate certain audio functions.
- Some functions may be limited while driving.
- Some items may be grayed-out during driving to reduce the potential for distraction. You can select them when the vehicle is stopped.
- Wearing gloves may limit or prevent touchscreen response.



You can change the touchscreen sensitivity setting.

 [How to Customize the General Settings](#)  P.250

### Selecting an audio source

Select audio source icon in the header area, then select an icon on the source list to switch the audio source.

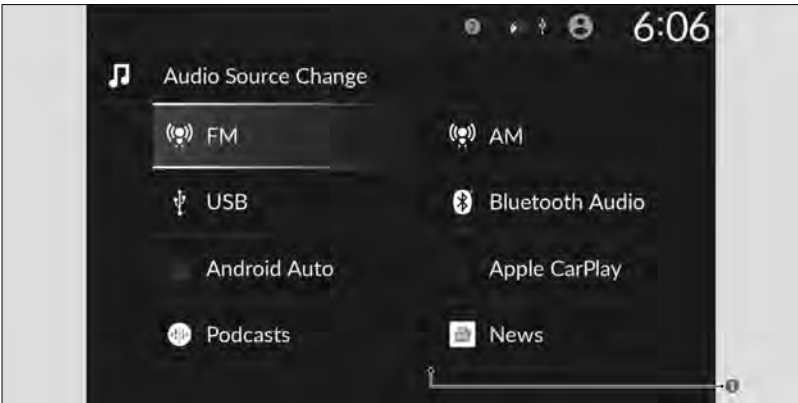

### 1 Source List

## ■ Status bar

Displays information about your vehicle, connected devices, or etc. You can select the status bar to view more details in the status area.

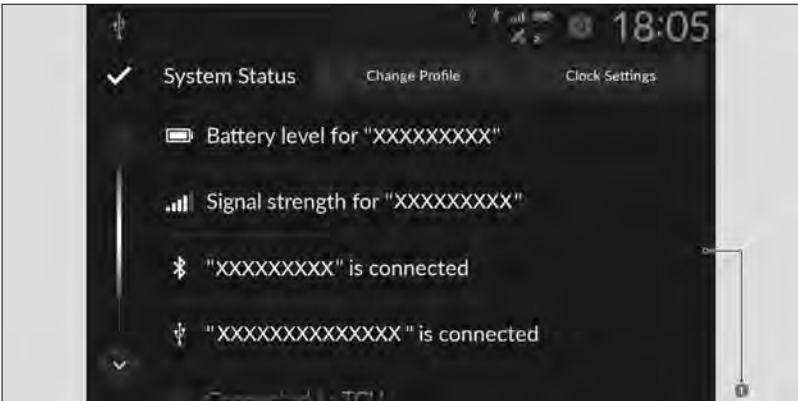

### 1 Status Area

## ■ Mode change switch bar

You can also select any application from the mode change switch bar. Shortcuts can be edited to open other applications, but **Google Assistant**<sup>\*1</sup> or **Alexa**<sup>\*1</sup> cannot be edited.

\*1: Displayed in the default assist app.



## USB Ports

### On the front panel



### USB charging/connector port ( )

The USB port is for charging devices, playing audio files, and connecting compatible phones with Android Auto or Apple CarPlay.

» To prevent any potential issues, be sure to use an Apple MFi Certified Lightning Connector for Apple CarPlay. The USB cables should be certified by USB-IF to be compliant with USB 2.0 Standard.

### USB charging port ( )

These USB ports are only for charging devices.

» You cannot play audio files even if an audio device is connected.

### On the back of the console compartment\*

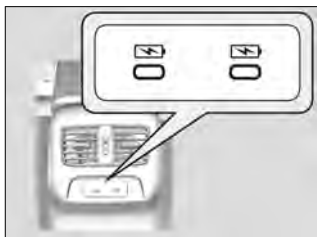

- We recommend backing up your data before using the device in your vehicle.
- Messages displayed on the Audio System may vary depending on the device model and software version.
- Some devices may not work even if they are connected to the USB ports.

#### Supplementary information about USB Charging:

- The USB port supports USB Power Delivery.
- USB standard output  
When using 1 port: 5V/3A(15W), 9V/3A(27W), 15V/3A(45W), 20V/3A(60W)  
When using both ports: 5V/3A(15W), 9V/3A(27W), 15V/3A(45W), 20V/2.25A(45W), Max 60W in total  
For amperage details, read the operating manual of the device that needs to be charged.
- The USB port also supports PPS (Programmable Power Supply). PPS 5.0V-21V (Max 60W).
- Charging may not start or may operate slowly depending on the connected devices and cables. Using only one port while not connecting anything (including cables) to the other port may solve the issue.



Do not leave the device or USB flash drive in the vehicle. Direct sunlight and high temperatures may damage it.

\*: Not available on all models

! Do not connect the device or USB flash drive using a hub, as they will not operate if you do.

! Do not use a device such as a card reader or hard disk drive, as the device or your files may be damaged.

## Audio Remote Controls

3

Controls

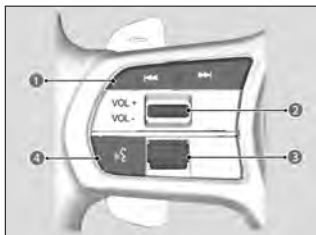

Allow you to operate the audio system while driving. The information is shown on the driver information interface.

- 1 (Seek/Skip) Buttons
- 2 **VOL+ / VOL-** (Volume) Switch
- 3 Left Selector Wheel
- 4 (Talk) Button

! Depending on the device you connect, some functions may not be available.

## Seek/Skip Buttons

- When listening to the radio
  - Press** : To select the next preset radio station.
  - Press** : To select the previous preset radio station.
  - Press and hold** : To select the next strong station.
  - Press and hold** : To select the previous strong station.
- When listening to a wired connection, USB flash drive, *Bluetooth*® Audio, or Smartphone Connection
  - Press** : To skip to the next song.
  - Press** : To go back to the beginning of the current or previous song.
- When listening to a USB flash drive
  - Press and hold** : To skip to the next folder.
  - Press and hold** : To go back to the previous folder.

## VOL+/VOL- (Volume) Switch

**Press Up:** To increase the volume.

**Press Down:** To decrease the volume.

## Left Selector Wheel

To switch between audio modes, roll up or down and then press the left selector wheel.

» When cycling through the list, audio modes appear in the following order.

### ▼ Models with 9" Color Touchscreen with Google built-in

**Back → Phone → FM → AM → USB → Bluetooth → AUDIO Apps → Apple CarPlay → Android Auto → Alexa → Customize display**

### ▼ Models with 9" Color Touchscreen

**Back → Phone → FM → AM → USB → Bluetooth → AUDIO Apps → Apple CarPlay → Android Auto → Customize display**

## Connecting a Device

With a connected device, you can use Apple CarPlay or Android Auto to listen to audio files.

» Depending on the app used, smartphone battery may decrease even with a wired connection.



Always make sure your vehicle is parked in a safe location before connecting a device.

## About Wired Connections

Connect a smartphone or USB flash drive to the USB charging/connector port (  ).

» You may need to operate the smartphone.

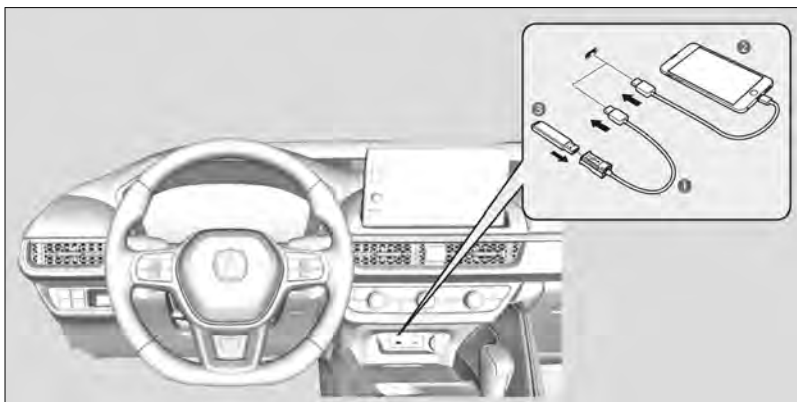

- ① USB Cable
- ② Device
- ③ USB Flash Drive

## About Wireless Connections

You can modify *Bluetooth*® function settings.

Once you have paired a phone, you can see it displayed on the screen with one or more icons on the right side. These icons indicate the following:

: The phone is compatible with HFL.\*<sup>1</sup>

: The phone is compatible with *Bluetooth*® Audio.\*<sup>1</sup>

: The phone is compatible with HFL and *Bluetooth*® Audio.\*<sup>2</sup>

: The phone is compatible with Apple CarPlay.

: The phone is compatible with Android Auto.

Phone Pairing Tips:

- Up to six phones can be paired.
- Your phone's battery may drain faster when it is paired to the system.

\*1: Models with 9" Color Touchscreen

\*2: Models with 9" Color Touchscreen with Google built-in

### ▼ Models with 9" Color Touchscreen with Google built-in

#### ■ *Bluetooth*® setup

You can turn *Bluetooth*® function on and off.

[1] Press the (Home) button.

[2] Select **General Settings**.

[3] Select **Connections**.

[4] Select **Manage Device Connections**.

[5] Select **Options**.

[6] Select **Bluetooth**, then select **On**.

[7] Select **Yes**.

## ■ To pair a cell phone (when there is no phone paired to the system)

- [1] Press the  (Home) button.
- [2] Select **General Settings**.
- [3] Select **Connections**.
- [4] Select **Manage Device Connections**.
- [5] Select **Connect New Device**.
- [6] Make sure your phone is in search or discoverable mode.
- [7] Select **Acura ADX** from your phone.
  - » If you want to pair a phone from this audio system, select **Search for Devices**, and then select your phone when it appears on the list.
- [8] The system gives you a pairing code on the audio/information screen. This may vary by phone.
  - » Confirm if the pairing code on the screen and your phone matches.
  - » If the audio system has not sent the pairing code to your phone, the pairing code authentication screen will be displayed. Check the pairing code and select **Pair**.
- [9] Select **Yes** if you want to set this phone as the preferred connection.

## ■ To change the currently paired phone

- [1] Press the  (Home) button.
- [2] Select **General Settings**.
- [3] Select **Connections**.
- [4] Select **Manage Device Connections**.
- [5] Select a phone to connect.
  - » HFL disconnects the connected phone and starts searching for another paired phone.
  - » You can set the connected phone priority. Check the box on the phone you want to prioritize.
- [6] Select **Bluetooth, Apple CarPlay, or Android Auto**.
- [7] Select **Yes**.

- To pair other phones, select **+ Connect New Device** from the *Bluetooth*® screen.

## ■ To delete a paired phone

- [1] Press the  (Home) button.
- [2] Select **General Settings**.
- [3] Select **Connections**.
- [4] Select **Manage Device Connections**.
- [5] Select a phone you want to delete.
- [6] Select **Delete Device**.
- [7] A confirmation message appears on the screen. Select **Delete**.

## ▼ Models with 9" Color Touchscreen

### ■ *Bluetooth*® setup

This audio system unavailable to set the *Bluetooth*® function. *Bluetooth*® function is always ON.

### ■ To pair a cell phone (when there is no phone paired to the system)

- [1] Press the  (Home) button.
- [2] Select **General Settings**.
- [3] Select **Connections**.
- [4] Select **+ Connect New Device**.
- [5] Make sure your phone is in search or discoverable mode.
- [6] Select **Acura ADX** from your phone.
  - » If you want to pair a phone from this audio system, select **Search for Devices**, and then select your phone when it appears on the list.
- [7] The system gives you a pairing code on the audio/information screen. This may vary by phone.
  - » Confirm if the pairing code on the screen and your phone matches.
- [8] Select **Yes** if you want to set this phone as the preferred connection.

### ■ To change the currently paired phone

- [1] Press the  (Home) button.
- [2] Select **General Settings**.
- [3] Select **Connections**.
- [4] Select the function icon for the phone you want to connect.
  - » HFL disconnects the previously connected phone and starts searching for another paired phone.

### ■ To delete a paired phone

- [1] Press the  (Home) button.
- [2] Select **General Settings**.
- [3] Select **Connections**.
- [4] Select **Manage Device Connections**.
  - » The screen changes to a device list.
- [5] Select a phone you want to delete.
- [6] A confirmation message appears on the screen. Select **Delete**.
  - » When the device is connected to Android Auto or Apple CarPlay, a confirmation message appears. Select **Delete**.

## About System Updates\*

When a software update is available for your vehicle, a notification will be displayed on the audio/information screen.

Instructions for performing updates via the audio information screen are included in this manual.

For details on other methods of performing an update, please ask a dealer.

System updates that change specifications may result in some discrepancies with the information in this owner's manual.

\*: Not available on all models

## ■ Instructions

🔍 System Updates ▶ P.220

# 9" Color Touchscreen

## Start Up

The 9" color touchscreen starts automatically when you set the power mode to ACCESSORY or ON. At start-up, the following screen about the disclaimer will be displayed.

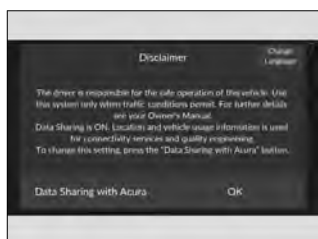

Select **OK**.

- » If you want to change the setting for data upload, select **Data Sharing with Acura**, then select the ON/OFF setting on the **Data Sharing with Acura** setting screen.
- » If you do not select **OK** within 5 seconds, the home screen will be displayed.

## Data Sharing with Acura Setting

**Enable:** Data communication available.

**Disable:** Data communication unavailable.

## Reboot Audio

You can reboot the audio system.

- [1] Press and hold the  (Home) button for a certain period of time.
- [2] Select **Reboot**.

## Adjusting the Clock

You can adjust the time in the clock display with the power mode in ON.



- [1] Press the  (Home) button.
- [2] Select **General Settings**.
- [3] Select **System**.
- [4] Select **Date & Time**.
- [5] Select **Set Date & Time**.
- [6] Select **Automatic Date & Time** to set to off.

### To adjust time:

- [7] Select **Set Time**.
- [8] Select  or .
- [9] Select  **Back** icon to set the time.



### To adjust date:

- [7] Select **Set Date**.
- [8] Select  or .
- [9] Select  **Back** icon to set the date.



You can customize the clock display to show the 12 hour clock or 24 hour clock.

 How to Customize the General Settings ▶ P.215



You can customize the date display.

 How to Customize the General Settings ▶ P.215

## Adjusting the Sound

- [1] Press the  (Home) button.
- [2] Select **Sound**.
- [3] Select the setting you want to change.

The following settings items can be set:

- **Bass / Mid / Treble** : Bass, Midrange, Treble
- **Balance / Fader** : Balance, Fader
- **Speed Volume Compensation** : Sets the amount of volume increase.

## Changing the Display Setting

You can change the screen brightness.

- [1] Press the  (Home) button.
- [2] Select **General Settings**.
- [3] Select **Display**.
- [4] Select the setting you want.

## Playing AM/FM Radio

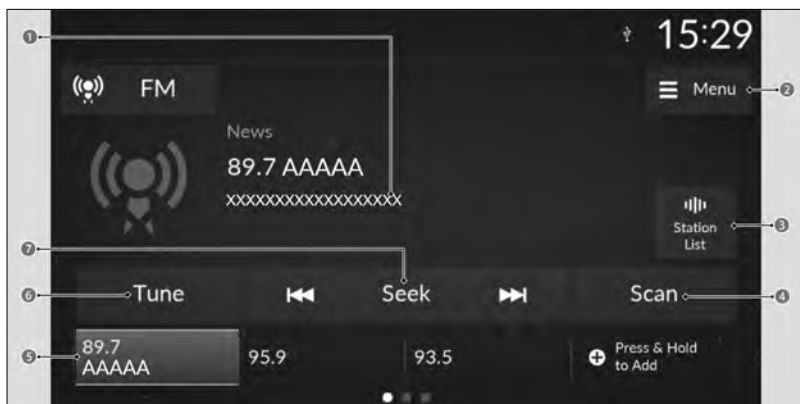

3

Controls

- 1 Text Area
- 2 Menu Icon
- 3 Station List Icon
- 4 Scan Icon
- 5 Preset Icons
- 6 Tune Icon
- 7 Seek Icons

## Radio Data System (RDS)

Provides text data information related to your selected RDS-capable FM station.

» When you select an RDS-capable FM station, the RDS automatically turns on, and the frequency display changes to the station name. When the signal of that station becomes weak, the display continues to show the last displayed station name.

### To find an RDS station from station list

- [1] Select **Station List** to display a list while listening to an FM station.
- [2] Select the station.

### Update list

Updates your available station list at any time.

- [1] Select **Station List** while listening to an FM station.
- [2] Select **Refresh**.

### Radio text

Displays the radio text for RDS stations in the text area.

## Scan Icon

Samples each of the strongest stations on the selected band for a few seconds. To turn off scan, select **Stop**.

## Favorite Station

To switch the favorite station, select the preset icon.

» Swipe the preset icon area to display the next preset icons.

To add a station:

[1] Tune to the selected station.

[2] Select and hold **Press & Hold to Add**.

» You can store 12 AM/FM stations into the preset memory.

## Editing a favorite station

Select and hold the desired favorite station icon.



The following items are available:

- **Remove Favorite:** Delete the favorite station icon from the favorite station list.
- » **Replace with** (number): Replace the stored favorite station icon.

## Tune Icon

Select to use the on-screen keyboard for entering the radio frequency directly.

## Seek Icons

Select  or  to search the selected band up or down for a station with a strong signal.

## About Audio Playback

By connecting a device to the audio system, you can play audio files.



It may be illegal to perform some data device functions while driving.



- Available operating functions vary on models or versions. Some functions may not be available on the vehicle's audio system.
- Depending on the connected device, in some cases, the name of the artist, album, or track may not appear correctly.

## About Play Modes



### Shuffle/Repeat

Repeatedly select the shuffle or repeat icon until you find a play mode option of your preference.

#### Shuffle

-  **Shuffle OFF:** Shuffle mode to off.
-  **Shuffle all:** Plays all available songs in random order.

#### Repeat

-  **Repeat off:** Repeat mode to off.
-  **Repeat track:** Repeats the current song.
-  **Repeat all<sup>1</sup>:** Repeats all songs.

\*1: When playing a song using *Bluetooth*<sup>®</sup> or wired device

## Audio Playback via Wired Connection

Using your USB connector, connect the device to the USB port, then select the **Audio Source** icon. Then select the **USB**.

 About Wired Connections ▶ P.194

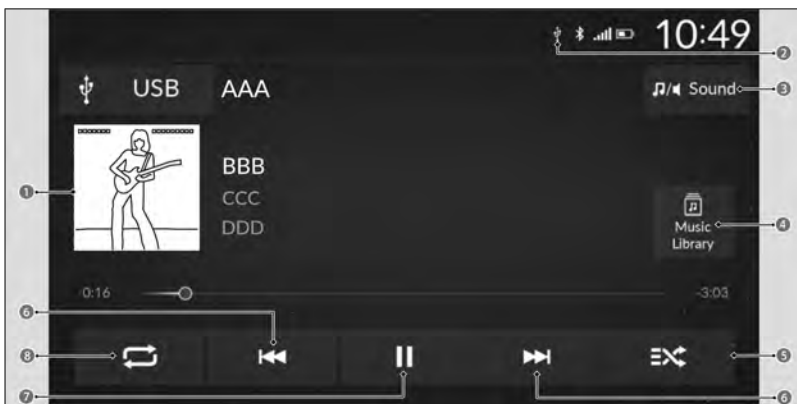



- 1 Cover Art
- 2 USB indicator
- 3 Sound Icon
- 4 Music Library Icon
- 5 Shuffle Icon
- 6 Track Icons
- 7 Play/Pause Icon
- 8 Repeat Icon

- While an iPhone is connected via Apple CarPlay, audio files on the iPhone can only be played using Apple CarPlay.

## How to select a song from the music search list

- [1] Select **Music Library**.
- [2] Select a category.
- [3] Select a song.
  - » Select an item repeatedly until a desired item you want to listen to is displayed.

## Track icon

Press  or  to change songs.  
Press and hold to move rapidly within a song.

## Audio Playback via USB Device

The audio system can read certain USB drive formats to play audio files.

 Compatible iPod, iPhone, and USB Flash Drives ▶ P.259

After connecting a USB device, select the **Audio Source** icon. Then select the **USB**.

 About Wired Connections ▶ P.194

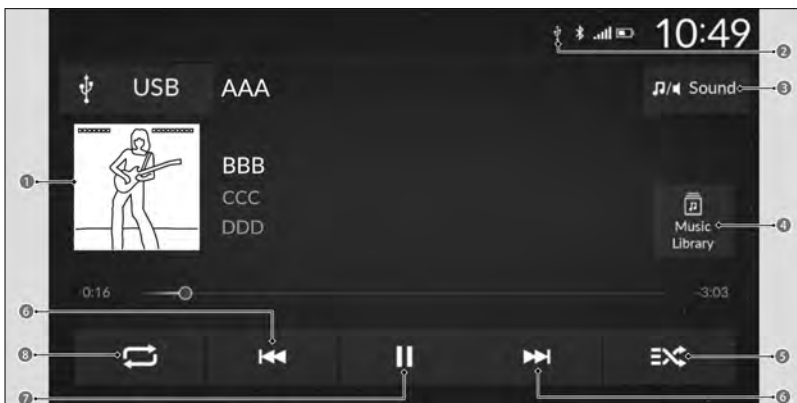



- 1 Cover Art
- 2 USB indicator
- 3 Sound Icon
- 4 Music Library Icon
- 5 Shuffle Icon
- 6 Track Icons
- 7 Play/Pause Icon
- 8 Repeat Icon

 WMA files protected by digital rights management (DRM) cannot be played.

## How to select a song from the music search list

- [1] Select **Music Library**.
- [2] Select a folder.
- [3] Select a file.

## Track icon

Select  or  to change files.  
Select and hold to move rapidly within a file.

## Audio Playback via *Bluetooth*® Device

Your audio system allows you to listen to audio files from your *Bluetooth*®-compatible phone.

Connect a *Bluetooth*® compatible device to the system. Select the **Audio Source** icon then select the **Bluetooth Audio**.

 About Wireless Connections ▶ P.195

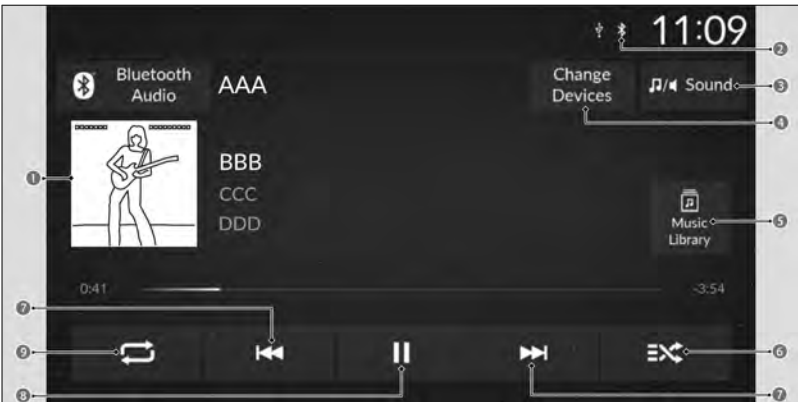

- 1 Cover Art
- 2 *Bluetooth*® indicator
- 3 Sound Icon
- 4 Change Devices Icon
- 5 Music Library Icon
- 6 Shuffle Icon
- 7 Track Icons
- 8 Play/Pause Icon
- 9 Repeat Icon

- Not all *Bluetooth*®-enabled phones with streaming audio capabilities are compatible with the system. For a list of compatible phones:
  - U.S.: Visit <https://mygarage.honda.com/s/acura-handsfreelink-compatibility-check>, or call 1-888-528-7876.
  - Canada: Call 1-855-490-7351.
- Only one phone can be used with HFL at a time. When there are more than two paired phones in the vehicle, the system automatically connects to the prioritized phone. You can assign priority to a phone in the *Bluetooth*® Settings menu.

 About Wireless Connections ▶ P.195

- If a phone is currently connected via Apple CarPlay or Android Auto, *Bluetooth*® Audio from that phone is unavailable.

 About Wireless Connections ▶ P.195

- To play the audio files, you may need to operate your phone. If so, follow the phone manufacturer's operating instructions.
- Switching to another mode pauses the audio files playing from your phone.
- If any audio device is connected to the USB port, you may need to select **Audio Source** to select the **Bluetooth Audio**.

## How to select a song from the music search list

- [1] Select **Music Library**.
- [2] Select a folder.
- [3] Select a song.

## Track icon

Press  or  to change songs.

## Apple CarPlay

If you connect an Apple CarPlay-compatible iPhone to the system via USB port or wirelessly and the  (Connect) button is pressed, you can operate Apple CarPlay on the audio/information screen.

 Connecting a Device ▶ P.194

- Only iPhone 6s or newer versions with iOS 10.0.2 or later are compatible with Apple CarPlay.
- Park in a safe place before connecting your iPhone to Apple CarPlay and when launching any compatible apps.
- You can also use the method below to set up Apple CarPlay:  
Select **General Settings**→**Connections**→ icon.
- While connected to Apple CarPlay, it is not possible to use the *Bluetooth*® Audio or *Bluetooth*® HandsFreeLink®. Calls and audio playback will be handled exclusively through Apple CarPlay. If you want to make a call with the *Bluetooth*® HandsFreeLink®, turn Apple CarPlay OFF or detach the USB cable from your iPhone. Other previously paired phones can also use the *Bluetooth*® Audio.
- Apple CarPlay and Android Auto cannot run at the same time.

- For details on countries and regions where Apple CarPlay is available, as well as information pertaining to function, refer to the Apple homepage.
- **Apple CarPlay Operating Requirements & Limitations**  
Apple CarPlay requires a compatible iPhone with an active cellular connection and data plan. Your carrier's rate plans will apply.  
Changes in operating systems, hardware, software, and other technology integral to providing Apple CarPlay functionality, as well as new or revised governmental regulations, may result in a decrease or cessation of Apple CarPlay functionality and services. Acura cannot and does not provide any warranty or guarantee of future Apple CarPlay performance or functionality.
- It is possible to use third-party apps if they are compatible with Apple CarPlay. Refer to the Apple homepage for information on compatible apps.
- Use of Apple CarPlay will result in the collection of certain user and vehicle information (such as vehicle location, speed, and status) from your iPhone to enhance the Apple CarPlay experience. You will need to consent to the sharing of this information on the audio/information screen.
- **Use of user and vehicle information**  
The use and handling of user and vehicle information transmitted to/from your iPhone by Apple CarPlay is governed by the Apple iOS terms and conditions and Apple's Privacy Policy.

## Apple CarPlay Menu

For details on available applications, please refer to the Apple CarPlay homepage. Apps displayed on your screen can be changed with your iPhone. Select the **Acura** icon on the Apple CarPlay menu screen to go back to the home screen.

## Connect Apple CarPlay Using the USB Cable

Connect the iPhone to the USB port.

 [About Wired Connections](#) ▶ P.194

If another phone is already connected to the audio system, the confirmation screen will appear, and then select **Yes**.

## Connect Apple CarPlay Wirelessly

- [1] Select **Apple CarPlay** icon.
- [2] Select **Connect New Device**.  
Pair the iPhone to the vehicle's *Bluetooth*® HandsFreeLink (HFL) system.

 [About Wireless Connections](#) ▶ P.195

- [3] Select **Yes**.
  - » If your iPhone asks for permission to accept an Apple CarPlay connection, accept to connect.

## Operating Apple CarPlay with Siri

Press and hold the  (Talk) button to activate Siri. Press again to deactivate Siri.

 [Audio Remote Controls](#) ▶ P.193



Below are examples of questions and commands for Siri:

- What movies are playing today?
- Call dad at work.
- What song is this?
- How's the weather tomorrow?
- Read my latest email.

For more information, please visit [www.apple.com/ios/siri](http://www.apple.com/ios/siri).

## Android Auto™

If you connect an Android™ phone to the system, via USB port or wirelessly, and the  (Connect) button is pressed, you can operate Android Auto on the audio/information screen.

 Connecting a Device ▶ P.194

- We recommend that you update Android OS to the latest version when using Android Auto. *Bluetooth*® A2DP cannot be used while your phone is connected to Android Auto.
- To use Android Auto on a smartphone with Android 9.0 (Pie) or earlier, you need to download the Android Auto app from Google Play to your smartphone.
- Android and Android Auto are trademarks of Google LLC.
- Park in a safe place before connecting your Android phone to Android Auto and when launching any compatible apps.
- Apple CarPlay and Android Auto cannot run at the same time.
- For details on countries and regions where Android Auto is available, as well as information pertaining to function, refer to the Android Auto homepage.
- When your Android phone is connected to Android Auto, it is not possible to use the *Bluetooth*® Audio.
- **Android Auto Operating Requirements & Limitations**  
Android Auto requires a compatible Android phone with an active cellular connection and data plan. Your carrier's rate plans will apply.  
Changes in operating systems, hardware, software, and other technology integral to providing Android Auto functionality, as well as new or revised governmental regulations, may result in a decrease or cessation of Android Auto functionality and services. Acura cannot and does not provide any warranty or guarantee of future Android Auto performance or functionality.
- It is possible to use third-party apps if they are compatible with Android Auto. Refer to the Android Auto homepage for information on compatible apps.
- **Use of user and vehicle information**  
The use and handling of user and vehicle information transmitted to/from your phone by Android Auto is governed by the Google's Privacy Policy.

## Android Auto Menu

For details on available applications, please refer to the Android Auto homepage. Apps displayed on your screen can be changed with your smartphone.

Select the **Acura** icon on the Android Auto menu screen to go back to the home screen.

## Connect Android Auto Using the USB Cable

Connect the Android phone to the USB port.

 About Wired Connections ▶ P.194

If another phone is already connected to the audio system, the confirmation screen will appear, and then select **Yes**.

## Connect Android Auto Wirelessly

- [1] Select **Android Auto** icon.
- [2] Select **Connect New Device**.
- [3] Pair the Android phone to the vehicle's *Bluetooth*® HandsFreeLink (HFL) system.

 About Wireless Connections ▶ P.195

- [4] Select **Yes**.

» If your Android phone asks for permission to accept an Android Auto connection, accept to connect.

## Operating Android Auto with Google Assistant

Press and hold the  (Talk) button to talk to Google Assistant.

 Audio Remote Controls ▶ P.193

Below are examples of commands you can give with Google Assistant:

- Reply to text.
- Call my wife.
- Navigate to Acura.
- Play my music.
- Send a text message to my wife.
- Call flower shop.

For more information, please refer to the Android Auto homepage.

## Bluetooth® HandsFreeLink®

*Bluetooth*® HandsFreeLink® allows you to place and receive phone calls using your vehicle's audio system without handling your cell phone. Select the phone function operation area when your phone is connected to the system wirelessly.

 About Wireless Connections ▶ P.195

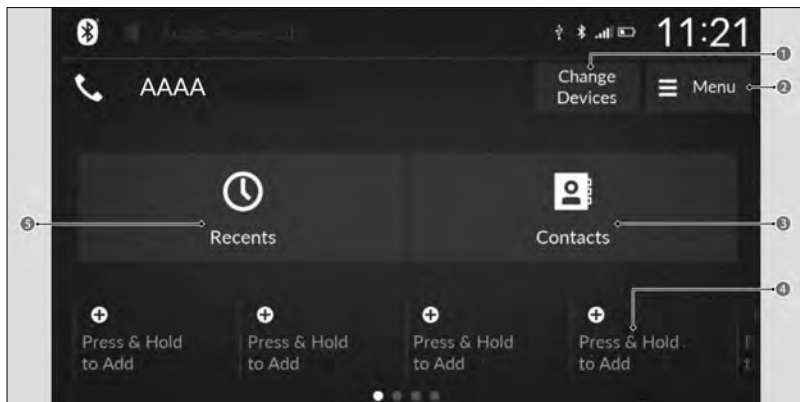

- 1 Change Devices Icon
- 2 Menu Icon
- 3 Contacts Icon
- 4 Favorite Contacts
- 5 Recents Icon

- **Bluetooth® Wireless Technology**

The *Bluetooth®* word mark and logos are registered trademarks owned by *Bluetooth®* SIG, Inc., and any use of such marks by Honda Motor Co., Ltd., is under license. Other trademarks and trade names are those of their respective owners.

- **HFL Limitations**

An incoming call on HFL will interrupt the audio system when it is playing. It will resume when the call is ended.

- When you select a name from the list in the cell phonebook, you can see a category icon. The icons indicate what types of numbers are stored for that name.
- On some phones, it may not be possible to import the category icons to the system.
- Depending on the connected cell phone, some features may not be available.

- **Voice control tips**

Aim the vents away from the ceiling and close the windows, as noise coming from them may interfere with the microphone.

If the microphone picks up voices other than yours, the command may be misinterpreted.

- State or local laws may prohibit the operation of handheld electronic devices while operating a vehicle.
- Up to 16 favorite contacts can be stored. If there is no entry in the system, the pop-up notification appears on the screen.

 Favorite Contacts ▶ P.211

- Up to 100 call histories can be stored. If there is no call history, call history is disabled.

## HFL Status Display

The audio/information screen notifies you when there is an incoming call.



### 1 Bluetooth® Indicator

Appears when your phone is connected to HFL.

### 2 Signal Strength

### 3 Battery Level Status

### 4 Name saved in contacts/Caller's Number (if not registered)

- The information that appears on the audio/information screen varies between phone models.

## Favorite Contacts

### To add a favorite contact

- [1] Press the  (Home) button.
- [2] Select phone function operation area.
- [3] Select and hold **Press & Hold to Add** icon.
- [4] Select **From Recents**, **From Contacts**, or **Using Enter Number**.

#### From Recents, From Contacts:

- [5] Select a phone number or contact name.

#### Using Enter Number:

- [5] Input number, and select **OK**.

### To delete a favorite contact

- [1] Press the  (Home) button.
- [2] Select phone function operation area.
- [3] Select and hold a favorite contact.
- [4] Select **Remove Favorite**.

## ■ To edit a favorite contact

- [1] Press the  (Home) button.
- [2] Select phone function operation area.
- [3] Select and hold a favorite contact.
- [4] Select **Edit Favorites**.
- [5] Select a setting you want.
- [6] Select **OK**, **Enter**, or select type.

## Making a Call

You can make calls by inputting any phone number, or by using the imported Recent Calls, Favorite Contacts, and Contacts entries.

## ■ To make a call using the imported phonebook

- [1] Press the  (Home) button.
- [2] Select **Contacts**.
- [3] Select a name.
  - » The phonebook is stored alphabetically.

### If more than one number is registered:

- [4] Select a number.
  - » Dialing starts automatically.

## ■ To make a call using a phone number

- [1] Press the  (Home) button.
- [2] Select phone function operation area.
- [3] Select **Menu**.
- [4] Select **Using Enter Number**.
- [5] Select a number.
- [6] Select **Call**.
  - » Dialing starts automatically.

## ■ To make a call using the call history

Call history is stored by **All**, **Dialed**, **Missed**, or **Received**.

- [1] Press the  (Home) button.
- [2] Select **Recents**.
  - » You can sort by **All**, **Dialed**, **Missed**, or **Received**. Select the icon on the upper right of the screen.
- [3] Select a number or contact name.
  - » Dialing starts automatically.

The call history displays the last 100 all, dialed, missed, or received calls. (Appears only when a phone is connected to the system.)

## To make a call using a favorite contact entry

- [1] Press the  (Home) button.
- [2] Select phone function operation area.
- [3] Select a favorite contact.
  - » Dialing starts automatically.

## Receiving a Call

When there is an incoming call, an audible notification sounds (if activated) and the **Incoming Call...** screen appears.

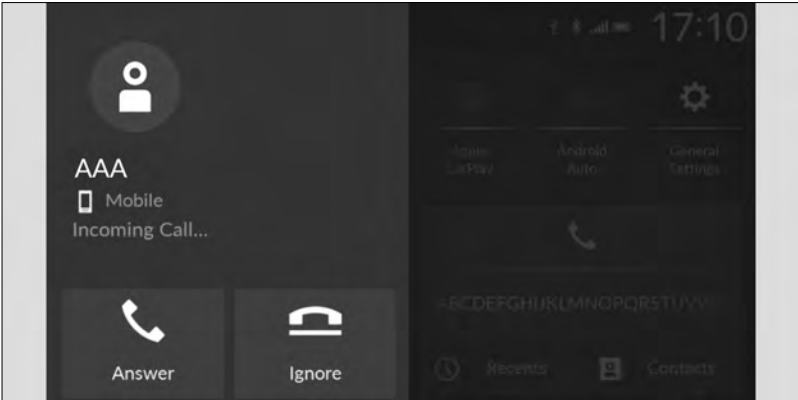

**To answer the call:** Select the  **Answer** icon.

**To decline or end the call:** Select the  **Ignore** icon.

### Call Waiting

Select  **Answer** icon to put the current call on hold to answer the incoming call.

Select  **Ignore** icon to ignore the incoming call if you do not want to answer it.

Select  **Hang Up** icon if you want to hang up the current call.

## Options During a Call

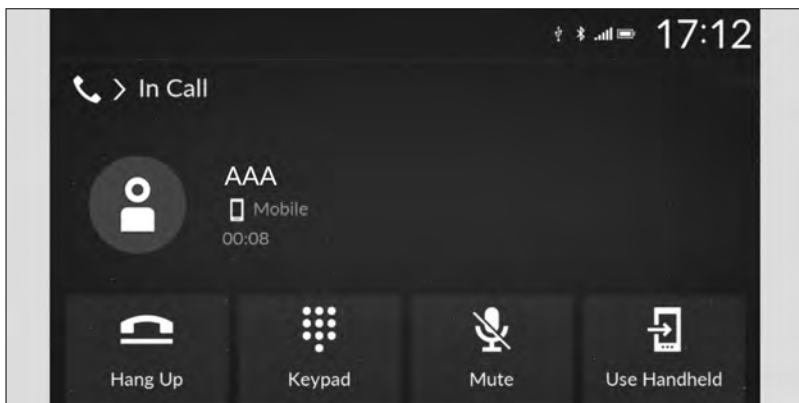

The following options are available during a call.

- **Use Handheld:** Transfer a call from the system to your phone.
- **Mute:** Mute your voice.
- **Keypad:** Send numbers during a call. This is useful when you call a menu-driven phone system.
- **Hang Up:** End the call. Calls can also be ended from the driver information interface by moving the left selector wheel up and down.

## Phone Menu Screen

By selecting **Menu** icon and selecting **Auto Sync Phone**, Set calls to automatically transfer from your phone to HFL when you enter the vehicle.

The incoming call volume setting is configured from **General Settings**.

 [How to Customize the General Settings](#) ▶ P.215

## Customized Features

Use the audio/information screen to customize certain features.



When you customize settings:

- Make sure that the vehicle is at a complete stop.
- Put the transmission into **P**.

## How to Customize the General Settings

While the vehicle is at a complete stop with the power mode in ON, select **General Settings** on the home screen.

### List of Customizable Options

#### System

##### Date & Time → Time Format

12H/24H<sup>\*1</sup>

##### Date & Time → Set Date & Time

##### Automatic Date & Time

On<sup>\*1</sup>/Off

##### Auto Daylight Saving Time

On/Off<sup>\*1</sup>

##### Set Date

Adjusts date.

 Adjusting the Clock ▶ P.199

##### Set Time

Adjusts time.

 Adjusting the Clock ▶ P.199

##### Date & Time → Time Zone

##### (Select time zone)

Changes the time zone manually.

#### Connections

##### Options → Priority Device

Changes priority device.

##### Options → Name

Changes vehicle name for *Bluetooth*® connection setting.

##### Options → MAC Address

Displays the MAC address.

##### Date & Time → Date Format

MM/DD/YYYY<sup>\*1</sup>/YYYY/MM/DD

##### Language

English<sup>\*1</sup>/Français/Español

##### Factory Data Reset

Cancel/Continue

##### Touch Panel Sensitivity

Low<sup>\*1</sup>/High

##### Legal Information

Shows the legal information.

\*1: Default Setting



### (Saved Devices)

Connects, disconnects, or deletes a paired phone.

🔍 Wireless Connection ▶P.195

## Display

### Brightness

Changes the brightness of the audio/information screen.

### Night Mode\*<sup>1</sup>

Changes to the night mode.

### Contrast

Changes the contrast of the audio/information screen.

### Display Off

Turns the audio/information screen brightness off.

### Black Level

Changes the black level of the audio/information screen.

### Reset to Default

Resets all customized settings in the Display setting.

### Day Mode\*<sup>1</sup>

Changes to the daytime mode.

\*1: When the AID sensor is disabled.

## Data Sharing with Acura

### Data Sharing with Acura

Disable/Enable\*<sup>1</sup>

\*1: Default Setting

## Sound

### Bass / Mid / Treble → Treble

Adjusts the settings of the audio speakers' sound.

🔍 Adjusting the Sound ▶P.200

### Bass / Mid / Treble → Reset to Default

Resets customized settings in the **Bass / Mid / Treble** settings.

### Bass / Mid / Treble → Midrange

Adjusts the settings of the audio speakers' sound.

🔍 Adjusting the Sound ▶P.200

### Balance / Fader

Adjusts the settings of the audio speakers' sound.

🔍 Adjusting the Sound ▶P.200

### Bass / Mid / Treble → Bass

Adjusts the settings of the audio speakers' sound.

🔍 Adjusting the Sound ▶P.200

### Balance / Fader → Reset to Default

Resets customized settings in the **Balance / Fader** settings.

**Speed Volume Compensation**

Adjusts the settings of the audio speakers' sound.

🔍 Adjusting the Sound ▶ P.200

**Sound Volume****System Sounds**

0~2<sup>\*1</sup>~3

**Voice Recognition**

0~6<sup>\*1</sup>~11

**Navigation Guidance**

0~6<sup>\*1</sup>~11

**Ringtone**

0~20<sup>\*1</sup>~40

**Rear Camera****Fixed Guideline**

On<sup>\*1</sup>/Off

**Dynamic Guideline**

On<sup>\*1</sup>/Off

**Phone Calls**

0~20<sup>\*1</sup>~40

**Reset to Default**

Resets all customized settings in the Sound Volume setting.

\*1: Default Setting

**Cross Traffic Monitor**

On<sup>\*1</sup>/Off

\*1: Default Setting

**Defaulting All the Settings**

Reset all the menu and customized settings as the factory defaults.

- [1] Press the  (Home) button.
- [2] Select **General Settings**.
- [3] Select **System**.
- [4] Select **Factory Data Reset**.
  - » A confirmation message appears on the screen.
- [5] Select **Continue** to reset the settings.
- [6] Select **Continue** again to reset the settings.

- When you transfer the vehicle to a third-party, reset all settings to default and delete all personal data.
- If you perform Factory Data Reset, it will reset the preinstalled apps to their factory default.

# 9" Color Touchscreen with Google built-in

## Start Up

The 9" color touchscreen with Google built-in starts automatically when you set the power mode to ACCESSORY or ON. At start-up, the following screen about the disclaimer will be displayed. When adding a new user, entry of user information is required at start-up.

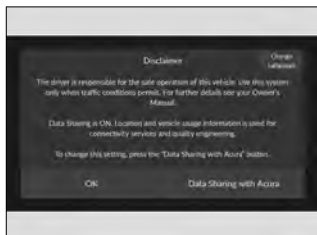

Select **OK**.

- » If you want to change the settings for data upload, select **Data Sharing with Acura**, then select the ON/OFF settings.
- » If you do not select **OK**, the system will automatically be switched to the home screen, or the top screen of the last executed application, after a certain period of time.
- » If there is no registered device, select **OK** and the *Bluetooth*® pairing screen will be displayed.

About Wireless Connections ▶ P.195

### Data Sharing with Acura Setting

**Enable:** Data communication available.

**Disable:** Data communication unavailable.

## Registering New User Information

- [1] Read the disclaimer screen and select **OK**.
- [2] Select **Set up profile**.
  - » If you want to change the language, select **English (United States)**.
- [3] **Name your profile** and select **Next**.
- [4] You can view the terms and conditions of the Google Services agreement.
- [5] On the System-wide permission Settings screen, select the data you give permission for the system to access, and select **Accept**.
- [6] Select **Done for now**.
  - » By selecting **Profile lock**, you can set security settings for your profile.
  - » By selecting **Set up Google Assistant and apps**, you can customize settings related to Google. An internet connection is required to change settings.

Wi-Fi Connection ▶ P.232

Refer to Google Homepage for more information on how to set up a profile.



Additional information for Google apps and services is available at [www.acura.com](http://www.acura.com) (U.S.) or [www.acura.ca](http://www.acura.ca) (English) / [www.acura.ca/fr](http://www.acura.ca/fr) (French) (Canada).

## Reboot Audio

You can reboot the audio system.

[1] Press and hold the  (Home) button for a certain period of time.

[2] Select **Reboot**.

» If **Safe Mode** is selected, the audio system will be rebooted with third-party applications turned off. After the power mode has been turned off once, third-party applications can be used again.

## Home Screen

App icons can be added, deleted, or moved on the home screen.

- You cannot delete the **All Apps** icon.
- Apps will not be deleted by deleting the icon on the home screen.
- Select **Tips** to show tips. To hide them, select it again.

### To Add/Remove App Icons on the Home Screen

App icons can be added or removed on the home screen.

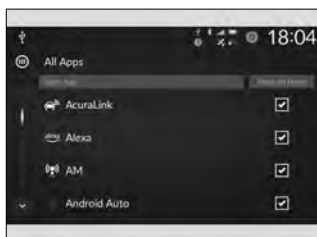

[1] Press the  (Home) button.



[2] Select **All Apps**.

[3] Select the apps you want to add or remove and check/uncheck the box.

### To Move/Remove App Icons on the Home Screen

You can change where apps are located or delete apps on the home screen.



[1] Press the  (Home) button.

- [2] Select and hold an app icon.
- [3] Drag and drop the app icon to where you want it to be.
  - » Drag and drop the icon you want to remove to the **Hide** icon.
- [4] Press the  (Home) button or  (Back) button.
  - » The screen will return to the home screen.

## To Store Shortcut Icons on the Home Screen

You can store up to five icons on the mode change switch bar.



- [1] Press the  (Home) button.
- [2] Select and hold an app icon.
- [3] Select **Edit Shortcuts**.
- [4] Drag and drop the app icon you want to store to the mode change switch bar.
  - » You can also store app icons in the mode change switch bar by selecting icon → shortcut location.
- [5] Press the  (Home) button or  (Back) button.
  - » The screen will return to the home screen.

## System Updates

System Updates uses the telematics control unit (TCU) or Wi-Fi communication capability to operate.

When an update for your system becomes available, a screen prompting you to update your system will be displayed on the audio/information screen.

- If new software has been released, perform an update as soon as possible.
- If a system update fails, please consult a dealer.
- System updates that change specifications may result in some discrepancies with the information in this owner's manual. For the most up-to-date information, please refer to the Acura homepage.
- Certain features may not be available during system updates.

## Performing System Updates

- [1] Press the  (Home) button.
- [2] Select **System Updates**.
- [3] Select **Agree to Update while power mode is OFF** to give permission for the update.
  - » The installation progress screen displays.
  - » While the power mode is set to OFF, an update started notification displays for a few seconds.

[4] The next time the power mode is turned to ON, the system update results screen will be displayed.

» System update results can also be viewed from **Settings → Update History** within **System Updates**.

**!** Make sure your vehicle is stopped in a safe location before starting a system update.

**!** If you have pressed **Agree to Update while power mode is OFF** on the agreement screen when an update is being offered, or **Automatic Update\*** is set to ON, and the update started notification is not displayed even though the power mode is set to OFF, it may be due to one or more of the conditions listed below. For more information, consult a dealer.

- The shift position is not in **P**.
- The vehicle is providing one or more emergency notifications.
- The 12-Volt Battery is depleted.

**!** If the system is being updated via Wi-Fi, you will not be able to use this feature in some situations based on Wi-Fi authentication methods. For example:

- The connection requires you to log in.
- Agreement to terms of use is required.

**!** If you are disconnected from the network, the download will be stopped. Download is resumed when a new network connection is established.

## System Updates Settings

By selecting **Settings** and selecting a settings item, you can change or confirm the system update settings.

The following settings items can be set.

- **Automatic Update\***: You can change to automatic update.
- **Automatic Download**: You can change to automatic download.
- **Control Unit Versions**: You can confirm the version and update status.
- **Connection Setup**: You can connect to the internet via a Wi-Fi network.

 Wi-Fi Connection ▶ P.232

\*: Not available on all models

- **Update History:** You can confirm the update history.



To perform a **System Update** via Wi-Fi, check the box next to your desired network in **General Settings → Connections → Wi-Fi → Options → Add Network** or **Saved Networks**.

## Trip Computer

Displays the trip computer information.

- **Current Drive** tab: Displays the current trip information.
- **Trip A/Trip B** tab: Displays information for the current and three previous drives. The information is stored every time you reset Trip A/B.  
To reset Trip A/B, select **Menu**, then select **Delete Trip History**.  
To change the setting of how to reset Trip A/B, select **Menu**, then select **“Trip A” Reset Timing** or **“Trip B” Reset Timing**.



## Adjusting the Clock

You can adjust the time manually in the audio/information screen when the power mode is in ON.



» The Guest user cannot adjust the clock.

- [1] Press the  (Home) button.
- [2] Select **General Settings**.
- [3] Select **System**.
- [4] Select **Date & Time**.
- [5] Select **Set Date & Time**.
- [6] Select **Automatic Date & Time** to set to off.

### To adjust time:



- [7] Select **Set Time**.
- [8] Select  or .
- [9] Press the  (Back) button to set the time.

### To adjust date:

- [7] Select **Set Date**.
- [8] Select  or .
- [9] Press the  (Back) button to set the date.

You can also adjust the clock by touching the clock displayed in the header area of the audio/information screen, clock displayed on the home screen, or **All Apps**.

- [1] Touch the clock on the screen.  
The clock screen of the face-type appears.

- [2] Select **Menu**.
- [3] Select **Date & Time**.
- [4] Select **Set Date & Time**.
- [5] Select **Set Date** or **Set Time**.
- [6] Adjust the date, hours, and minutes by selecting  or .
- [7] Press the  (Back) button to set the time.



You can customize the clock display to show the 12 hour clock or 24 hour clock.

 [How to Customize the General Settings](#) ▶ P.250



You can customize the date display.

 [How to Customize the General Settings](#) ▶ P.250

## Adjusting the Sound

- [1] Press the  (Home) button.
- [2] Select an audio app icon.
- [3] Select **Sound**.
- [4] Select the option you want to change.

The following settings items can be set.:

- **Beosonic Tone & Surround**: Tone, Surround level
- **Center / Roof Speaker Volume**: Roof speaker, center speaker
- **Audio Zones & Balance / Fader**: Driver Only, Front Only, Rear Only, Full Vehicle, Balance, Fader
- **Speed Volume Compensation**: Sets the amount of volume increase.

You can also adjust the sound by the following procedure.

- [1] Press the  (Home) button.
- [2] Select **General Settings**.
- [3] Select **Sound**.

To reset each setting for **Beosonic Tone & Surround**, **Center / Roof Speaker Volume**, and **Audio Zones & Balance / Fader**, select **Reset to Default** on each setting screen.

## Changing the Display Setting

You can change the brightness of the audio/information screen.

- [1] Press the  (Home) button.
- [2] Select **General Settings**.
- [3] Select **Display**.
- [4] Select the setting you want.



» To reset the settings, select **Reset to Default**.

## Alexa Built-In

You can talk to Amazon Alexa through the audio system. With Alexa, you can:

- Stream music
- Check the weather
- Answer questions
- Control smart home devices
- And more with supported Alexa skills

### Support Resources

For more information or client support:

- Call Acura Client Relations at 1-800-382-2238.
- Go to <https://www.amazon.com/alexa-support>.



You can change the voice assistant from Google Assistant to Alexa.

[How to Customize the General Settings](#) ▶ P.250

## Using Alexa

Once you sign into Alexa in the vehicle, you can use Alexa without opening the app. You can trigger Alexa by doing any of the following:

- Say the wake word "Alexa" from anywhere in the audio system.
- Press the (Talk) button on the steering wheel.
- Select the **Alexa** icon from inside the app.

### Troubleshooting Tips:

- Make sure you are connected to Alexa via Wi-Fi network, AT&T Vehicle Data Plan, or AcuraLink®.
- If using an AT&T Vehicle Data Plan, confirm that your subscription is active.
- Make sure you are logged into your Amazon account.

### Deleting Your Alexa Settings from the Vehicle

For your privacy and security, if you transfer the vehicle to a third-party, reset all vehicle settings to default and delete all personal data. Also, remove the vehicle from the list of devices in your phone's Alexa app.

[Defaulting All the Settings](#) ▶ P.258

## Playing AM/FM Radio

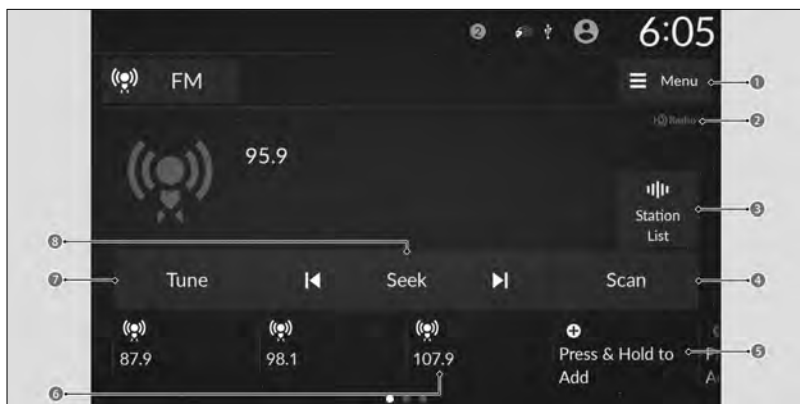

3

Controls

- 1 Menu Icon
- 2 HD Radio™ Icon
- 3 Station List
- 4 Scan Icon
- 5 Press & Hold to Add
- 6 Preset Icons
- 7 Tune Icon
- 8 Seek Icons

### HD Subchannel

Displays the subchannel list when an HD Radio™ station is selected while listening to an FM station.

- [1] Select **Station List**.
- [2] Select the channel number.

### AM/FM Settings

By selecting **Menu** → **HD Radio** → settings, you can change the AM/FM settings. The following settings items can be set.

- **HD Radio:** Automatically choose a digital or an analog channel, or listen to analog only.
- **Artwork:** Turns the artwork display on and off.

### Station List

Lists the strongest stations on the selected band.

- [1] Select **Station List** to display a list.
- [2] Select the station.

## Manual update

Updates your available station list at any time.

- [1] Select **Station List** to display a list.
- [2] Select **Refresh**.

## Radio Data System (RDS)

Provides text data information related to your selected RDS-capable FM station.

- » When you select an RDS-capable FM station, the RDS automatically turns on, and the frequency display changes to the station name. When the signal of that station becomes weak, the display continues to show the last displayed station name.

### To find an RDS station from station list

- [1] Select **Station List** to display a list while listening to an FM station.
- [2] Select the station.

## Manual update

Updates your available station list at any time.

- [1] Select **Station List** to display a list while listening to an FM station.
- [2] Select **Refresh**.

## Scan Icon

Samples each of the strongest stations on the selected band for a few seconds. To turn off scan, select **Stop** or press the  (Back) button.

## Favorite Station

To switch the favorite station, select the preset icon.

- » Swipe the preset icon area to display the next preset icons.

To add a station:

- [1] Tune to the selected station.
- [2] Select and hold **Press & Hold to Add**.
  - » You can store 12 AM/FM stations into preset memory.

### Editing a favorite station

Select and hold the desired favorite station icon.



The following items are available:

- **Remove Favorite:** Delete the favorite station icon from the favorite station list.
- **Replace with** (number): Replace the stored favorite station icon.
- **Add to Home:** Add the shortcut icon of the stored favorite station to the home screen.

## Tune Icon

Select to use the on-screen keyboard for entering the radio frequency directly.

## Seek Icons

Select  or  to search the selected band up or down for a station with a strong signal.

## About Audio Playback

By connecting a device to the audio system, you can play audio files.



It may be illegal to perform some data device functions while driving.



- Available operating functions vary on models or versions. Some functions may not be available on the vehicle's audio system.
- Depending on the connected device, in some cases, the name of the artist, album, or track may not appear correctly.

## About Play Modes





### Shuffle/Repeat

Repeatedly select the shuffle or repeat icon until you find a play mode option of your preference.

#### Shuffle

-  **Shuffle OFF:** Shuffle mode to off.
-  **Shuffle all:** Plays all available songs available in random order.
-  **Shuffle in folder**<sup>\*1</sup>: Plays all songs in the current folder in random order.

#### Repeat

-  **Repeat off:** Repeat mode to off.
-  **Repeat track:** Repeats the current song.
-  **Repeat folder/group**<sup>\*2</sup>: Repeats all songs in the current folder/group.
-  **Repeat all:** Repeats all songs (in the current folder<sup>\*2</sup>).

\*1: When playing a song via USB device

\*2: When playing a song using *Bluetooth*<sup>®</sup> Audio or via USB device

## Audio Playback via Wired Connection

Connect a device, such as an iPod or iPhone, then select the **USB** icon.

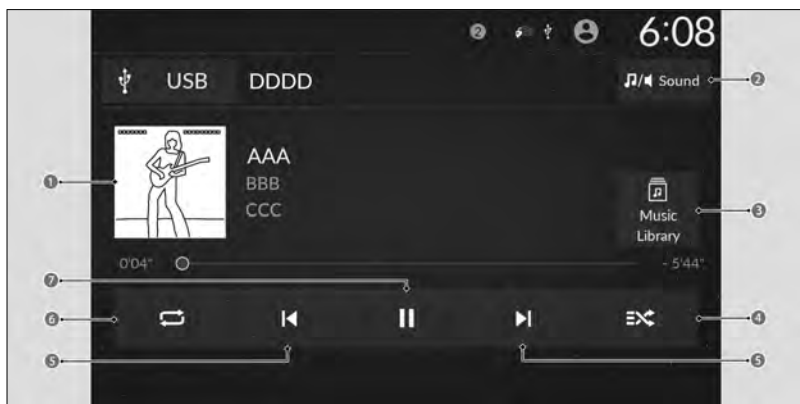

 About Wired Connections ▶ P.194



- 1 Cover Art
- 2 Sound Icon
- 3 Music Library Icon
- 4 Shuffle Icon
- 5 Track Icons
- 6 Repeat Icon
- 7 Play/Pause Icon

- While an iPhone is connected via Apple CarPlay, audio files on the iPhone can only be played using Apple CarPlay.

## Track icons

Select  or  to change songs.

Select and hold to move rapidly within a song.

## How to select a song from the music search list

- [1] Select **Music Library**.
- [2] Select a search category (e.g., Artists, Albums, etc.).
- [3] Continue making selections until you find the song of your choice.

## Audio Playback via USB Device

The audio system can read certain USB drive formats to play audio files.

 Compatible iPod, iPhone, and USB Flash Drives ▶P.259

After connecting a USB device, select the **USB** icon.

 About Wired Connections ▶P.194

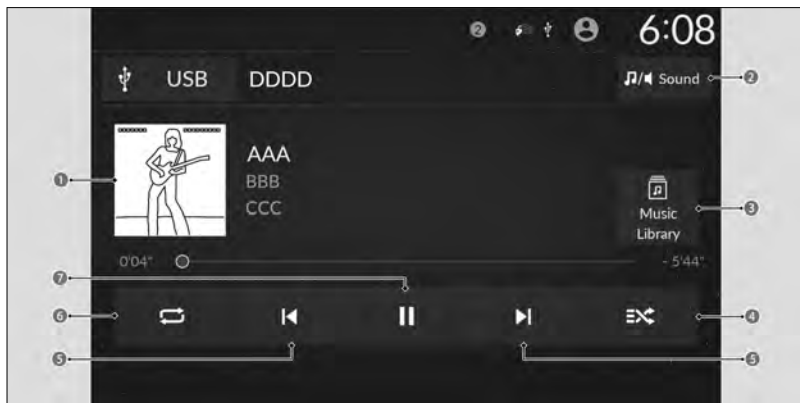

- 1 Cover Art
- 2 Sound Icon
- 3 Music Library Icon
- 4 Shuffle Icon
- 5 Track Icons
- 6 Repeat Icon
- 7 Play/Pause Icon

**!** WMA files protected by digital rights management (DRM) cannot be played.

### Track icons

Select **⏮** or **⏭** to change songs.  
 Select and hold to move rapidly within a song.

### How to select a song from the music search list

- [1] Select **Music Library**.
- [2] Select Current Playlist, or Music.
- [3] Select an item.
  - » The selection begins playing.

## Audio Playback via **Bluetooth®** Device

Your audio system allows you to listen to audio files from your **Bluetooth®**-compatible phone.

Connect a **Bluetooth®** compatible device to the system, then select the **Bluetooth** **Audio** icon.

**Q** About Wireless Connections ▶ P.195

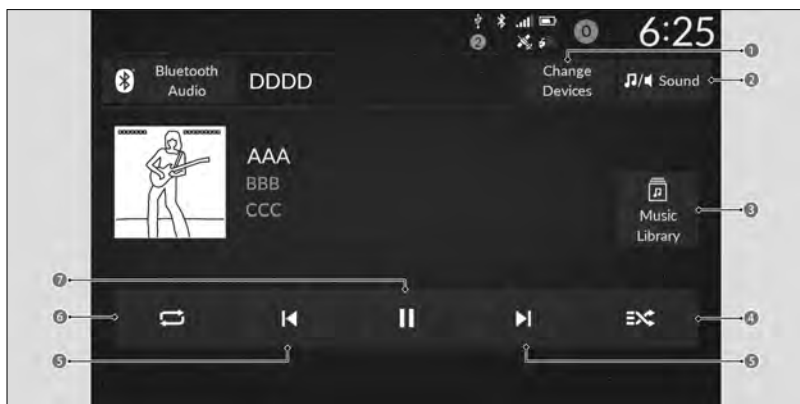

- 1 Change Devices
- 2 Sound Icon
- 3 Music Library Icon
- 4 Shuffle Icon
- 5 Track Icons
- 6 Repeat Icon
- 7 Play/Pause Icon

• Not all *Bluetooth*®-enabled phones with streaming audio capabilities are compatible with the system. For a list of compatible phones:

- U.S.: Visit <https://mygarage.honda.com/s/acura-handsfreelink-compatibility-check>, or call 1-888-528-7876.
- Canada: Call 1-855-490-7351.

• Only one phone can be used with HFL at a time. When there is more than one paired phone in the vehicle, the system automatically connects to the prioritized phone. You can assign priority to a phone in the *Bluetooth*® device list.

About Wireless Connections ▶P.195

- If more than one phone is paired to the HFL, there may be a delay before the system begins to play.
- If a phone is currently connected via Apple CarPlay, *Bluetooth*® Audio from that phone is unavailable.
- To play the audio files, you may need to operate your phone. If so, follow the phone manufacturer's operating instructions.
- Switching to another mode pauses the audio files playing from your phone.
- You can change the connected phone by selecting **Change Devices**.

About Wireless Connections ▶P.195

## Track icons

Select or to change songs.

Select and hold to move rapidly within a song.

## How to select a song from the music search list

- [1] Select **Music Library**.
- [2] Select a search category (e.g., Albums).
- [3] Select an item.
  - » The selection begins playing.

## AcuraLink®

AcuraLink® connects you to the latest information from Acura. You can connect your phone wirelessly through Wi-Fi or *Bluetooth*® and the AcuraLink® icon is selected, you can operate AcuraLink® on the audio/information screen.

🔍 Wi-Fi Connection ▶ P.232

🔍 About Wireless Connections ▶ P.195

- If your vehicle has a telematics control unit (TCU), you can use AcuraLink® without connecting the phone.
- The AcuraLink® connect app is compatible with most iPhone and Android phones.
- If the system is connected to the AcuraLink® connect app through *Bluetooth*® and another *Bluetooth*® audio device is connected, the *Bluetooth*® connection to the AcuraLink® connect app will be severed.
- Some cell phone carriers charge for tethering and smartphone data use. Check your phone's data subscription package.
- If there is an active connection to Apple CarPlay or Android Auto, AcuraLink® can only be connected through Wi-Fi.

## To Connect to AcuraLink®

You can use the following procedure to connect to AcuraLink®.

### To enable the AcuraLink® service

You must consent to location sharing to enable the AcuraLink® service.

- [1] Press the  (Home) button.
- [2] Select **General Settings**.
- [3] Select **Privacy**.
- [4] Select **Data Sharing with Acura**.
- [5] Select **Enable**.

### To link with AcuraLink®

You can see the connection guide screen after launching AcuraLink® when there is no connection to a network. If you do not need this guide, select check-box and select **OK**.



## AcuraLink® Menu

The following items can be used.

- **Vehicle Notifications:** Displays instruction messages when the vehicle needs service.
- **Contact Acura:** Displays tips for vehicle usage, and gets support via roadside service or customer service center.
- **Connect:** Displays your phone connection status and AcuraLink® subscription status.

## AcuraLink® Service

Is a subscription-based service that provides convenient features such as voice communication in case of emergency, online security, and one-on-one operator assistance.

- AcuraLink® also provides services you can operate from the Internet or your smartphone. To subscribe to AcuraLink®, or to get more information about all of its features, contact an Acura dealer, or visit <https://mygarage.honda.com/s/acuralink-marketing> (U.S.) or <https://www.acura.ca/en/acuralink> (English) / <https://www.acura.ca/fr/acuralink> (French) (Canada).

## Wi-Fi Connection



This vehicle is equipped with Wi-Fi connectivity. You can connect to a communication device. In addition, the vehicle can be used by other communication devices as a Wi-Fi hotspot via the telematics control unit (TCU).

- Use Wi-Fi Inside the Vehicle
- Connect to the In-vehicle Wi-Fi Hotspot

Wi-Fi and Wi-Fi Direct are registered trademarks of Wi-Fi Alliance®.



## Use Wi-Fi Inside the Vehicle

- [1] Press the  (Home) button.
- [2] Select **General Settings**.
- [3] Select **Connections**.
- [4] Select **Wi-Fi**.
  - » To change the Wi-Fi settings, select **Options**.
- [5] Select the access point you want to connect to the system.
- [6] Select **Connect**.
  - » When the connection is successful, the status text **Connected** next to the network name is displayed on the list.
- [7] Press the  (Home) button to go back to the home screen.

- You cannot go through the setting procedure while the vehicle is moving. Park in a safe place to set the audio system in Wi-Fi mode.
- Some cell phone carriers charge for tethering and smartphone data use. Check your phone's data subscription package.
- Check your phone manual to find out if the phone has Wi-Fi connectivity.
- You can confirm whether Wi-Fi connection is on or off with the  icon on the Wi-Fi network list. Transmission speed and others will not be displayed on this screen.
- In case of Wi-Fi connection with your phone, make sure your phone's Wi-Fi setting is in access point (tethering) mode.
- When you select **Access Point**, you can set up a wireless connection from the phone to the vehicle.

 How to Customize the General Settings ▶ P.250

## Connect to the In-vehicle Wi-Fi Hotspot

You can set the network as a Wi-Fi Hotspot of this audio system.

Use the following steps to set up.

- [1] Press the  (Home) button.
- [2] Select **General Settings**.
- [3] Select **Connections**.
- [4] Select **Data Connection Options**.
- [5] Select **Set Up Wi-Fi**.
- [6] Select **Options**.
- [7] Select **Add Network**.
- [8] Select **Connect**.

The following options are available for the setup.:

- **Network SSID:** Set this network name.
- **Security:** Set a password to be required when connecting a Wi-Fi device to this network.

## AT&T Hotspot

If you have subscribed to AT&T Hotspot services, your vehicle will provide data to connect your mobile devices to the Internet. You can use the AT&T Hotspot app to turn vehicle data on/off and monitor data usage left on your subscription.

- To use AT&T Hotspot services, your vehicle must be subscribed to a data plan. If your vehicle is not subscribed to a data plan, you can add vehicle data services at:  
U.S.: [www.att.com/acura](http://www.att.com/acura)  
Canada: <https://myvehicle.att.com/#/acura/learn?language=en&country=CA> (English)  
<https://myvehicle.att.com/#/acura/learn?language=fr&country=CA> (French)
- Alternatively, you can use your mobile hotspot to connect the vehicle and other mobile devices to the Internet.

 Wi-Fi Connection ▶ P.232

## AT&T Hotspot Menu

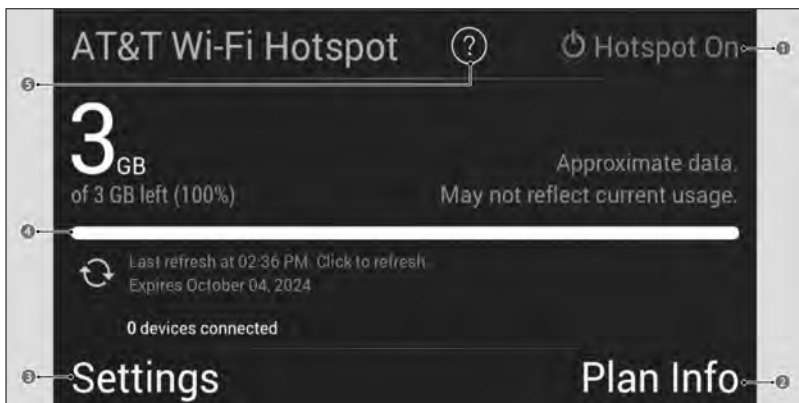

### 1 Hotspot Enable

Turn AT&T Hotspot on/off.

### 2 Plan Info

Shows your current AT&T subscription plan for the vehicle.

### 3 Settings

Shows the current username and password for vehicle Hotspot. **Settings** can be changed while the vehicle is not in motion.

### 4 Data Usage Bar

Check the current status of your data plan. This Usage Bar will show your current plan and how much data remains on your plan. Subscription plans for AT&T Hotspot can be added/modified at:

U.S.: [www.att.com/acura](http://www.att.com/acura)

Canada: <https://myvehicle.att.com/#/acura/learn?language=en&country=CA> (English)

<https://myvehicle.att.com/#/acura/learn?language=fr&country=CA> (French)

### 5 Help



## Apple CarPlay

If you connect an Apple CarPlay-compatible iPhone to the system, via USB port or wirelessly, and the **Apple CarPlay** icon is selected, you can operate Apple CarPlay on the audio/information screen.

🔍 Connecting a Device ▶ P.194



### 1 Apple CarPlay Icon

- Only iPhone 5s or newer versions with iOS 11.3 or later are compatible with Apple CarPlay.
- Park in a safe place before connecting your iPhone to Apple CarPlay and when launching any compatible apps.
- You can also use the method below to set up Apple CarPlay:  
Press the  (Home) button → Select **General Settings** → **Connections** → **Manage Device Connections** → Select device.
- While connected to Apple CarPlay, it is not possible to use the *Bluetooth*® Audio or HandsFreeLink®. Calls and audio playback will be handled exclusively through Apple CarPlay. If you want to make a call with *Bluetooth*® HandsFreeLink®, turn Apple CarPlay OFF or detach the USB cable from your iPhone. Other previously paired phones can also use *Bluetooth*® Audio.
- When using Hands Free, you can only control it with Siri.  
 Operating Apple CarPlay with Siri ▶ P.237
- Apple CarPlay and Android Auto cannot run at the same time.
- For details on countries and regions where Apple CarPlay is available, as well as information pertaining to function, refer to the Apple homepage.
- **Apple CarPlay Operating Requirements & Limitations**  
Apple CarPlay requires a compatible iPhone with an active cellular connection and data plan. Your carrier's rate plans will apply.  
Changes in operating systems, hardware, software, and other technology integral to providing Apple CarPlay functionality, as well as new or revised governmental regulations, may result in a decrease or cessation of Apple CarPlay functionality and services. Acura cannot and does not provide any warranty or guarantee of future Apple CarPlay performance or functionality.
- It is possible to use third-party apps if they are compatible with Apple CarPlay. Refer to the Apple homepage for information on compatible apps.
- Use of Apple CarPlay will result in the collection of certain user and vehicle information (such as vehicle location, speed, and status) from your iPhone to enhance the Apple CarPlay experience. You will need to consent to the sharing of this information on the audio/information screen.

- **Use of user and vehicle information**

The use and handling of user and vehicle information transmitted to/from your iPhone by Apple CarPlay is governed by the Apple iOS terms and conditions and Apple's Privacy Policy.

- Wireless Apple CarPlay and AT&T Hotspot cannot be used at the same time. When using Apple CarPlay and AT&T Hotspot at the same time, connect to Apple CarPlay with a USB cable.
- If there is a problem with the connection of your iPhone, an error code will be displayed.

 [How to Customize the General Settings](#) ▶ P.250

## Apple CarPlay Menu

For details on available applications, please refer to the Apple CarPlay homepage.

Apps displayed on your screen can be changed with your iPhone.

Select the **Acura** icon on the Apple CarPlay menu screen to go back to the home screen.

## Connect Apple CarPlay Using the USB Cable

Connect the iPhone to the USB port.

 [About Wired Connections](#) ▶ P.194

If another phone is already connected to the audio system, the confirmation screen will appear, and then select **Continue Connecting**.

## Connect Apple CarPlay Wirelessly

### ■ Connect Apple CarPlay wirelessly on the home screen

- [1] Press the  (Home) button.
- [2] Select **Apple CarPlay**.
- [3] Select **Check Device List** or **Connect New Phone**.
- [4] Pair the iPhone to the vehicle's *Bluetooth*® HandsFreeLink® (HFL) system.

 [About Wireless Connections](#) ▶ P.195



- [5] Select **Yes**.
  - » If your iPhone asks for permission to accept an Apple CarPlay connection, accept to connect.

### ■ Connect Apple CarPlay wirelessly on the *Bluetooth*® device list

- [1] Press the  (Home) button.
- [2] Select **General Settings**.
- [3] Select **Connections**.
- [4] Select **Manage Device Connections**.
- [5] Select **+ Connect New Device**.
- [6] Pair the iPhone to the vehicle's *Bluetooth*® HandsFreeLink® (HFL) system.

 [About Wireless Connections](#) ▶ P.195

- [7] Select  icon.

» If you select  icon, you cannot select  icon.

[8] Select **Connect**.

[9] Select **Yes**.

» If your iPhone asks for permission to accept an Apple CarPlay connection, accept to connect.



## ■ Connect Apple CarPlay wirelessly with the steering wheel

[1] Press and hold the  (Talk) button on the steering wheel.

[2] Pair the iPhone to the vehicle's *Bluetooth*® HandsFreeLink® (HFL) system.

 About Wireless Connections ▶P.195

[3] Select .

» If you select  icon, you cannot select  icon.

[4] Select **Connect**.

[5] Select **Yes**.

» If your iPhone asks for permission to accept an Apple CarPlay connection, accept to connect.

## Operating Apple CarPlay with Siri

Press and hold the  (Talk) button to activate Siri. Press again to deactivate Siri.

 Audio Remote Controls ▶P.193

Press and release to activate standard voice recognition system.

Below are examples of questions and commands for Siri:

- What movies are playing today?
- Call dad at work.
- What song is this?
- How's the weather tomorrow?
- Read my latest email.

For more information, please visit [www.apple.com/ios/siri](http://www.apple.com/ios/siri).

## Android Auto™

If you connect an Android™ phone to the system, via USB port or wirelessly, and the **Android Auto** icon is selected, you can operate Android Auto on the audio/information screen.

 Connecting a Device ▶P.194



### 1 Android Auto Icon

- We recommend that you update Android OS to the latest version when using Android Auto. Bluetooth® A2DP cannot be used while your phone is connected to Android Auto.
- To use Android Auto on a smartphone with Android 9.0 (Pie) or earlier, you need to download the Android Auto app from Google Play to your smartphone.
- Android and Android Auto are trademarks of Google LLC.
- Park in a safe place before connecting your Android phone to Android Auto and when launching any compatible apps.
- You can use the method below to change Android Auto settings after you have completed the initial setup:  
Press the  (Home) button → Select **General Settings** → **Connections** → **Manage Device Connections** → Select device.

- Apple CarPlay and Android Auto cannot run at the same time.
- To use each of Android Auto's features: say, "Hey Google" while the Android Auto screen is displayed, or press and hold the  (Talk) button to activate Google Assistant.

#### Operating Android Auto with Google Assistant ▶ P.240

- For details on countries and regions where Android Auto is available, as well as information pertaining to function, refer to the Android Auto homepage.
- **Android Auto Operating Requirements & Limitations**  
Android Auto requires a compatible Android phone with an active cellular connection and data plan. Your carrier's rate plans will apply.  
Changes in operating systems, hardware, software, and other technology integral to providing Android Auto functionality, as well as new or revised governmental regulations, may result in a decrease or cessation of Android Auto functionality and services. Acura cannot and does not provide any warranty or guarantee of future Android Auto performance or functionality.
- It is possible to use third-party apps if they are compatible with Android Auto. Refer to the Android Auto homepage for information on compatible apps.
- **Use of user and vehicle information**  
The use and handling of user and vehicle information transmitted to/from your phone by Android Auto is governed by Google's Privacy Policy.
- Wireless Android Auto and AT&T Hotspot cannot be used at the same time. When using Android Auto and AT&T Hotspot at the same time, connect to Android Auto with a USB cable.

- If there is a problem with the connection of your smartphone, an error code will be displayed.

 [How to Customize the General Settings](#) ▶ P.250

## Android Auto Menu

For details on available applications, please refer to the Android Auto homepage.

Apps displayed on your screen can be changed with your smartphone.

Select the **Acura** icon on the Android Auto menu screen to go back to the home screen.

## Connect Android Auto Using the USB Cable

Connect the Android phone to the USB port.

 [About Wired Connections](#) ▶ P.194

If another phone is already connected to the audio system, the confirmation screen will appear, and then select **Continue Connecting**.

## Connect Android Auto Wirelessly

### Connect Android Auto wirelessly on the home screen

- [1] Press the  (Home) button.
- [2] Select **Android Auto**.
- [3] Select **Check Device List** or **Connect New Phone**.
- [4] Pair the Android phone to the vehicle's *Bluetooth*® HandsFreeLink® (HFL) system.



 [About Wireless Connections](#) ▶ P.195

- [5] Select **Yes**.
  - » If your Android phone asks for permission to accept an Android Auto connection, accept to connect.

### Connect Android Auto wirelessly on the *Bluetooth*® device list

- [1] Press the  (Home) button.
- [2] Select **General Settings**.
- [3] Select **Connections**.
- [4] Select **Manage Device Connections**.
- [5] Select **+ Connect New Device**.
- [6] Pair the Android phone to the vehicle's *Bluetooth*® HandsFreeLink® (HFL) system.

 [About Wireless Connections](#) ▶ P.195

- [7] Select  icon.
  - » If you select  icon, you cannot select  icon.
- [8] Select **Connect**.
- [9] Select **Yes**.





- » If your Android phone asks for permission to accept an Android Auto connection, accept to connect.

## ■ Connect Android Auto wirelessly with the steering wheel

- [1] Press and hold the  (Talk) button on the steering wheel.
- [2] Pair the iPhone to the vehicle's *Bluetooth*® HandsFreeLink® (HFL) system.

 About Wireless Connections ▶P.195

- [3] Select  icon.
  - » If you select  icon, you cannot select  icon.
- [4] Select **Connect**.
- [5] Select **Yes**.
  - » If your Android phone asks for permission to accept an Android Auto connection, accept to connect.

## Operating Android Auto with Google Assistant

Press and hold the  (Talk) button to talk to Google Assistant.

 Audio Remote Controls ▶P.193

Press and release the  (Talk) button to activate the Google Assistant.

Below are examples of things you can ask Google Assistant

- Reply to text.
- Call my wife.
- Navigate to Acura.
- Play my music.
- Send a text message to my wife.
- Call flower shop.

For more information, please refer to the Android Auto homepage.

## Google built-in

You can use the features available with Google built-in on the audio/information screen.



- 1 Google Assistant
- 2 Google Maps
- 3 Google Play

- Google, Google Play, and Google Maps are trademarks of Google LLC.
- For more details on Google apps and services' features, visit the Google homepage.



- Additional information for Google apps and services is available at [acura.com](http://acura.com) (U.S.) or [www.acura.ca](http://www.acura.ca) (English) / [www.acura.ca/fr](http://www.acura.ca/fr) (French) (Canada).

## Google Assistant

You can operate features with hands-free help from Google Assistant.

You can activate Google Assistant by:

- Saying "Hey Google".
  - » Wake words vary by region and language. Refer to the Google homepage for more information.
- Press the  (Talk) button on the steering wheel.
- Select the Google Assistant icon on the audio/information screen.

Below are examples of things you can ask Google Assistant:

- Play music.
- Play radio.



You can customize language and other settings regarding Google Assistant.

[How to Customize the General Settings](#) ▶P.250

Refer to the Google homepage for more information.



## Google Maps

Google Maps helps you reach your next destination faster with real-time traffic info, automatic rerouting, and voice control.

- Operate when vehicle is stopped in a safe location.
- When your Google Account is linked with a valid user, destinations stored on other devices (home, work, favorites, previous searches, etc.) can be displayed. When the device and the vehicle are logged into the same Google Account, changing information on the device will change it on Google Maps as well.

## Google Play

Download your favorite apps on Google Play.

- The vehicle must be stopped in order to download an app.
- Operate when vehicle is stopped in a safe location.

## User Information

You can add and change users, as well as customize user settings. By registering a user, you can personalize your vehicle settings. You can select a user when the audio/information screen loads, even when the doors are open or unlocked.



### 1 User Information

By linking your profile with your Google Account, you can enjoy a more personalized experience with Google built-in. For more assistance on account linking, visit the Google homepage.



You can customize settings individually for each user.

[Q How to Customize the Profile Settings](#) ▶P.257

- You can customize security settings for each user. If you have forgotten security settings, you will need to delete the user and create a new one. If you have forgotten security settings for the Owner user, please contact a dealer or Acura Client Relations.

[Q Contacts](#) ▶P.444

- Certain features are unavailable when using a newly created user or the Guest user.

## Registering a User

[1] Select User Information.

» You can also add users when **Profile Settings** → **Change Profile** is selected.

[Q How to Customize the Profile Settings](#) ▶P.257

» You can add users even when the doors are open and unlocked.

[2] Select **Change Profile**.

[3] Select **+Add User**.

[4] Select **OK**.

[5] Enter User Information.

🔍 Start Up ▶ P.218

- You can add up to 4 users other than the Owner user and the Guest user.
- When you add a user, the audio/information screen is loaded under that user.

## Switching Users

[1] Select User Information.

- » You can also change users when **Profile Settings → Change Profile** is selected.

🔍 How to Customize the Profile Settings ▶ P.257

- » You can switch users even when the doors are open and unlocked.

[2] Select **Change Profile**.

[3] Select the user you want to use.

- Users with customized security settings can restrict screen operations by selecting the **Screen Lock** shortcut.

## Deleting Users

[1] Select **Profile Settings**.

[2] Select **Manage Profile**.

[3] Select **Profiles & accounts**.

[4] Select **Delete your profile**.

- When the profile currently being used is deleted, the audio/information screen is loaded under the Guest user.
- While using the Owner user, you can delete other users via **General Settings → Advanced Settings**.

🔍 How to Customize the General Settings ▶ P.250

- Depending on the version of your OS, the steps for deleting a user may differ from the instructions on this page. Follow the on-screen prompts.

## Bluetooth® HandsFreeLink®

*Bluetooth*® HandsFreeLink® allows you to place and receive phone calls using your vehicle's audio system without handling your cell phone. Select the **Phone** icon when your phone is connected to the system wirelessly.

🔍 About Wireless Connections ▶ P.195

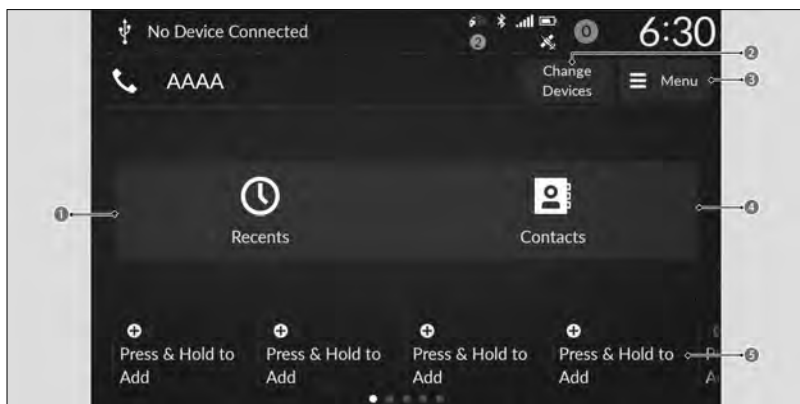

- 1 Recents
- 2 Change Devices
- 3 Menu
- 4 Contacts
- 5 Favorite Contacts

- To use the system, the *Bluetooth*® setting must be ON.

[Q How to Customize the General Settings ▶ P.250](#)

- *Bluetooth*® Wireless Technology

The *Bluetooth*® word mark and logos are registered trademarks owned by *Bluetooth*® SIG, Inc., and any use of such marks by Honda Motor Co., Ltd., is under license. Other trademarks and trade names are those of their respective owners.

- **HFL Limitations**

An incoming call on HFL will interrupt the audio system when it is playing. It will resume when the call is ended.

- When you select a name from the list in the cell phonebook, you can see a category icon. The icons indicate what types of numbers are stored for that name.
- On some phones, it may not be possible to import the category icons to the system.
- Depending on the connected cell phone, some features may not be available.

## HFL Status Display

The audio/information screen notifies you when there is an incoming call.



**1 Bluetooth® Indicator**

Appears when your phone is connected to HFL.

**2 Signal Strength**

**3 Battery Level Status**

**4 Name saved in contacts/Caller's Number (if not registered)**

- The information that appears on the audio/information screen varies between phone models.

## Favorite Contacts

### To add a favorite contact

- [1] Press the  (Home) button.
- [2] Select **Phone**.
- [3] Select and hold **Press & Hold to Add**.
- [4] Select **From Recents**, **From Contacts**, or **Using Enter Number**.

#### ▼ From Recents, From Contacts

- [5] Select a phone number.

#### ▼ Using Enter Number

- [5] Input number, and select **Enter**.

### To edit a favorite contact

- [1] Press the  (Home) button.
- [2] Select **Phone**.
- [3] Select and hold a favorite contact.
- [4] Select **Edit Favorites**.
  - » To delete a favorite contact, select **Remove Favorite**.
- [5] Select a setting you want.

- [6] Select **Enter** or select type.

## ■ Add a favorite contact to homepage

- [1] Press the  (Home) button.
- [2] Select **Phone**.
- [3] Select and hold a favorite contact.
- [4] Select **Add to Home**.

## Making a Call

You can make calls by inputting any phone number, or by using the imported recent calls, favorite contacts, and contacts entries.

### ■ To make a call using the imported phonebook

- [1] Press the  (Home) button.
- [2] Select **Phone**.
- [3] Select **Contacts**.
- [4] Select a name.
  - » You can sort by **First Name** or **Last Name**. Select the icon on the upper right of the screen.
- [5] Select a number.
  - » Dialing starts automatically.

### ■ To make a call using a phone number

- [1] Press the  (Home) button.
- [2] Select **Phone**.
- [3] Select **Menu**.
- [4] Select **Keypad**.
- [5] Select a number.
- [6] Select **Call**.
  - » Dialing starts automatically.

### ■ To make a call using the call history

Call history is stored by **All**, **Dialed**, **Missed**, and **Received**.

- [1] Press the  (Home) button
- [2] Select **Phone**.
- [3] Select **Recents**.
  - » You can sort by **All**, **Dialed**, **Missed**, or **Received** when you select the icon on the upper right of the screen.
- [4] Select a number or contact name.
  - » Dialing starts automatically.

The call history appears only when a phone is connected to the system.



## To make a call using a favorite contact entry

- [1] Press the  (Home) button.
- [2] Select **Phone**.
- [3] Select a favorite contact.
  - » Dialing starts automatically.

## Receiving a Call

When there is an incoming call, an audible notification sounds (if activated) and the **Incoming Call...** screen appears.

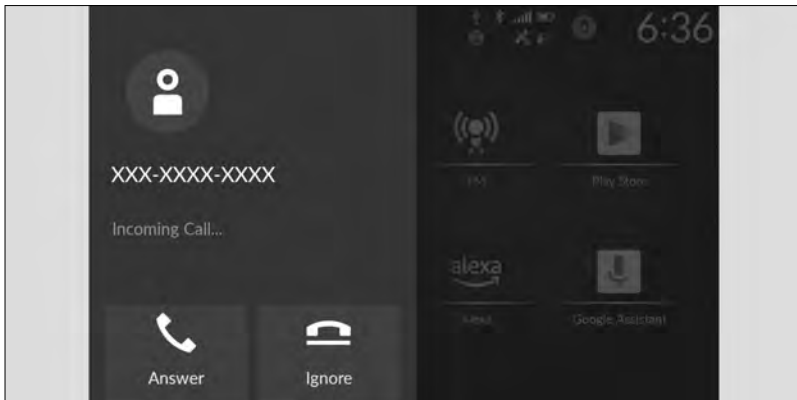

### To answer the call:

Select the **Answer** icon.





You can also answer the call using the left selector wheel roll up or down to select  (Answer) on the driver information interface.

### To decline or end the call:

Select the **Ignore** icon.

You can also ignore the call using the left selector wheel roll up or down to select  (Ignore) on the driver information interface.

### Call Waiting:

- Select  (**Answer**) icon to put the current call on hold to answer the incoming call.
- Select  using the left selector wheel to return to the current call.
- Select  (**Ignore**) icon to ignore the incoming call if you do not want to answer it.
- Select  if you want to hang up the current call.

## Options During a Call

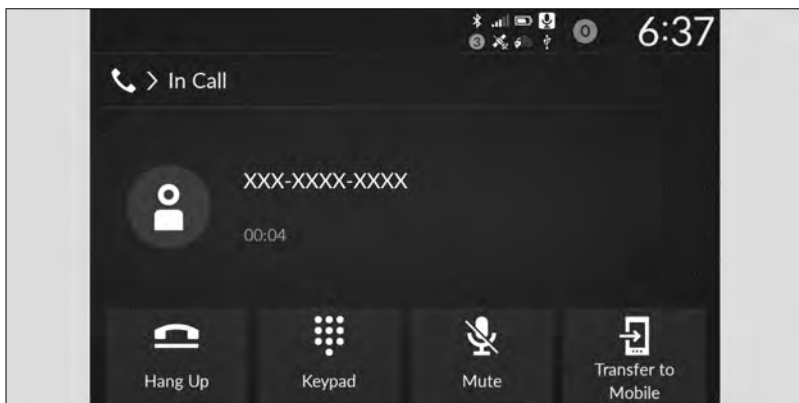

3

Controls

The following options are available during a call.

- **Hang Up:** End the call. Calls can also be ended from the driver information interface by moving the left selector wheel up and down.
- **Keypad:** Send numbers during a call. This is useful when you call a menu-driven phone system.
- **Mute:** Mute your voice.
- **Transfer to Mobile:** Transfer a call from the system to your phone.

## Phone Menu Screen

By selecting **Menu** and selecting a settings item, you can change the *Bluetooth*<sup>®</sup> HandsFreeLink<sup>®</sup> System settings.

The following settings items can be set.

- **Keypad:** Enter a phone number to dial.
- **Latest Call History:** Set whether the history shortcut is displayed in the phone screen.
- **Auto Sync Phone:** Set phonebook and call history data to be automatically imported when a phone is paired to HFL.
- **Auto Phone Call Transfer:** Set calls to automatically transfer from your phone to HFL when you enter the vehicle.
- **Ringtone:** Select a fixed ringtone or the one from the connected cell phone.

## Customized Features

Use the audio/information screen to customize certain features.



When you customize settings:

- Make sure that the vehicle is at a complete stop.
- Put the transmission into **P**.

## How to Customize the General Settings

With the power mode in ON, press the (Home) button → **General Settings** → setting item.

## List of Customizable Options

### System

#### Date & Time → Set Date & Time

##### Automatic Date & Time

On<sup>1</sup>/Off

##### Set Date

Adjusts date.

Adjusting the Clock ▶ P.222

##### Set Time

Adjusts clock.

Adjusting the Clock ▶ P.222

#### Date & Time → Time Zone

##### Automatic Time Zone

On<sup>1</sup>/Off

##### (Select time zone)

Changes the time zone manually.

#### Date & Time → Auto Daylight Saving Time

On<sup>1</sup>/Off

#### Date & Time → Date Format

Day-of-week, MM DD, YYYY<sup>1</sup>/  
YYYY.MM.DD Day-of-week/  
YYYY.MM.DD (Day-of-week)/Day-of-  
week DD.MM.YYYY/DD.MM.YYYY

#### Date & Time → Time Format

12H<sup>1</sup>/24H

#### Language

English<sup>1</sup>/Español/Français

#### Touch Panel Sensitivity

Low<sup>1</sup>/High

#### About → IP Address

Displays the Android setting items.

#### About → Wi-Fi MAC Address

Displays the Android setting items.

#### About → Bluetooth MAC Address

Displays the Android setting items.

#### About → Serial Number

Displays the Android setting items.

#### About → Up Time

Displays the Android setting items.

**About → Model Number**

Displays the Android setting items.

**About → Android Version**

Displays the Android setting items.

**About → Kernel Version**

Displays the Android setting items.

**About → Build Number**

Displays the Android setting items.

**Connections**

**Manage Device Connections → Options**

**Bluetooth**

On<sup>1</sup>/Off

**Priority Device Information**

Displays the priority device.

**Change Name**

Changes vehicle name for *Bluetooth*<sup>®</sup> connection setting.

**Smartphone Projection Screen Size**

Normal/Wide<sup>1</sup>

**Smartphone Projection Error Code**

Displays the error codes of the smartphone projection.

**Manage Device Connections → +  
Connect New Device**

Pairs a new phone to HFL.

Q Wireless Connection ▶ P.195

**Manage Device Connections → (Saved Devices)**

Connects, disconnects, or deletes a paired phone.

**About → Software Version**

Displays the Android setting items.

**Factory Data Reset**

**Cancel/Continue**

\*1: Default Setting

Q Wireless Connection ▶ P.195

**Wi-Fi → Options**

**Wi-Fi**

Off/On<sup>1</sup>

**Add Network**

Allows you to connect to a new external network.

**Saved Networks**

Delete a saved network or change update permission settings for the selected network.

**Access Point → Options**

**Access Point**

Off<sup>1</sup>/On

**Edit Access Point Settings**

Allows you to confirm hotspot settings and edit hotspot connection information.

**Data Connection Options → Set Up Wi-Fi**

Sets personal hotspot (phone tethering).

🔍 Wi-Fi Connection ▶ P.232

## Data Connection Options → Set Up Vehicle Data Plan

Sets AT&T vehicle data plan.

## Privacy

### Data Sharing with Acura

Disable/Enable<sup>\*1</sup>

#### Microphone

Turns the microphone on and off. eCall can still be used regardless of settings.

#### Location

Sets the data sharing permission for each function.

#### App permissions

Sets the data sharing permission for each function.

#### System-wide Permission Setting

Sets the data sharing permission for each function.

#### Infotainment system data

Sets the data sharing permission for each function.

## Display

#### Brightness

Changes the brightness of the audio/information screen.

#### Contrast

Changes the contrast of the audio/information screen.

🔍 AT&T Hotspot ▶ P.233

\*1: Default Setting

### Data sharing with Google<sup>\*2</sup>

Sets the data sharing permission for each function.

#### Ads

Sets the data sharing permission for each function.

### Google legal<sup>\*2</sup> → Google Terms of Service<sup>\*2</sup>

Displays the Google URL.

### Google legal<sup>\*2</sup> → Google Privacy Policy<sup>\*2</sup>

Displays the Google URL.

\*1: Default Setting

\*2: Please confirm the details on the audio/information screen. Specifications are subject to change via system updates, etc.

#### Black Level

Changes the black level of the audio/information screen.

#### Day Mode<sup>\*1</sup>

Changes to the daytime mode.

#### Night Mode<sup>\*1</sup>

Changes to the night mode.

### Display Off

Turns the audio/information screen brightness off.

\*1: When the AID sensor is disabled.

## Sound

### Beosonic Tone & Surround

Adjusts the settings of the audio speakers' sound.

 Adjusting the Sound ▶ P.223

### Audio Zones & Balance / Fader

Adjusts the settings of the audio speakers' sound.

 Adjusting the Sound ▶ P.223

### Center / Roof Speaker Volume

Adjusts the settings of the audio speakers' sound.

 Adjusting the Sound ▶ P.223

### Speed Volume Compensation

Adjusts the settings of the audio speakers' sound.

 Adjusting the Sound ▶ P.223

## Sound Volume

### System Sounds

0~2<sup>\*1</sup>~3

### Voice Recognition

1~2<sup>\*1</sup>~11

### Navigation Guidance

0~6<sup>\*1</sup>~11

### Phone Calls

0~20<sup>\*1</sup>~40

\*1: Default Setting

## Camera

### Multi View Camera → Guidelines

#### Fixed Guideline

On<sup>\*1</sup>/Off

#### Dynamic Guideline

On<sup>\*1</sup>/Off

### Multi View Camera → Customize

#### Show after Shifting from Reverse

On/Off<sup>\*1</sup>

### Auto Display When Obstacle is Detected

On<sup>\*1</sup>/Off

### Cross Traffic Monitor

On<sup>\*1</sup>/Off

\*1: Default Setting

## Voice Control

### Default Assist App

None/Alexa/Google Assistant<sup>\*1</sup>

### Listen for "Hey Siri"<sup>\*\*2</sup>

On/Off<sup>\*\*3</sup>

### Google Assistant

Sets the functions of **Google Assistant**.

\*1: Default Setting

\*2: Activates when the iPhone is connected.

\*3: Default Setting. (when Apple CarPlay is launched, setting will be switched to On)

## Security

You can customize security settings. Please confirm the details on the audio/information screen. Specifications are subject to change via system updates, etc.

## Google

You can customize Google settings. Please confirm the details on the audio/information screen. Specifications are subject to change via system updates, etc.

## Advanced Settings

You can customize advanced system settings. Please confirm the details on the audio/information screen. Specifications may be changed via system updates, etc.

## How to Customize the Vehicle Settings

With the power mode in ON, press the  (Home) button → **Vehicle Settings** → setting item.



## List of Customizable Options

### Driver Assist System Setup

#### Forward Collision Warning Distance

Long/Normal<sup>1</sup>/Short

#### ACC Forward Vehicle Detect Beep

On/Off<sup>1</sup>

#### Road Departure Mitigation Setting

Narrow/Normal<sup>1</sup>/Wide/Warning Only

#### Lane Keeping Assist Suspend Beep

On/Off<sup>1</sup>

#### Blind Spot Information

Audible and Visual Alert<sup>1</sup>/Visual Alert

#### Traffic Sign Recognition System Display Setting

On<sup>1</sup>/Off

#### Traffic Sign Recognition System Speed Limit Warning

On/Off<sup>1</sup>

### Meter Setup

#### Adjust Outside Temp. Display

-5 °F ~ ±0 °F<sup>1</sup> ~ +5 °F (U.S.)

-3 °C ~ ±0 °C<sup>1</sup> ~ +3 °C (Canada)

#### "Trip A" Reset Timing

When Fully Refueled/IGN Off/  
Manually Reset<sup>1</sup>

#### "Trip B" Reset Timing

When Fully Refueled/IGN Off/  
Manually Reset<sup>1</sup>

#### Adjust Alarm Volume

High/Mid<sup>1</sup>/Low

#### Speed Limit Warning Threshold Setting

Speed Limit<sup>1</sup>/Speed Limit +3mph/  
Speed Limit +5mph/Speed Limit  
+10mph (U.S.)

Speed Limit<sup>1</sup>/Speed Limit +5km/h/  
Speed Limit +10km/h/Speed Limit  
+15km/h (Canada)

#### Driver Attention Monitor

Tactile And Audible Alert<sup>1</sup>/Tactile  
Alert/Off

#### Rear Sensor Setting

On<sup>1</sup>/Off

\*1: Default Setting

#### Turn by Turn Auto Display

On<sup>1</sup>/Off

#### Rear Seat Reminder

On<sup>1</sup>/Off

#### Speed/Distance Units

km/h·km / mph·miles<sup>1</sup> (U.S.)

km/h·km<sup>1</sup>/mph·miles (Canada)

\*1: Default Setting



## Driving Position Setup

### Memory Position Link

On<sup>1</sup>/Off

## Keyless Access Setup

### Door Unlock Mode

Driver Door Only<sup>1</sup>/All Doors

### Keyless Access Light Flash

On<sup>1</sup>/Off

### Keyless Access Beep

On<sup>1</sup>/Off

## Lighting Setup

### Auto High-Beam

On<sup>1</sup>/Off

### Interior Light Dimming Time

60sec/30sec<sup>1</sup>/15sec

### Headlight Auto Off Timer

60sec/30sec/15sec<sup>1</sup>/0sec

## Door Setup

### Auto Door Lock

With Vehicle Speed<sup>1</sup>/Shift From P/  
Off

### Auto Door Unlock

All Doors When Driver's Door  
Opens<sup>1</sup>/All Doors With Shift To P/All  
Doors When Ignition Switched Off/  
Off

### Walk Away Auto Lock

On/Off<sup>1</sup>

### Seat Position Movement At Entry/ Exit

On<sup>1</sup>/Off

### Remote Start System On/Off\*

On<sup>1</sup>/Off

### Lockout Prevention

On<sup>1</sup>/Off

\*1: Default Setting

### Auto Light Sensitivity\*

Max/High/Mid<sup>1</sup>/Low/Min

### Auto Headlight On with Wiper On

On<sup>1</sup>/Off

\*1: Default Setting

### Keyless Lock Answer Back

On<sup>1</sup>/Off

### Keyless Remote Power Window Control

On<sup>1</sup>/Off

### Lock Presetting

On<sup>1</sup>/Off

### Auto Folding Door Mirror

On<sup>1</sup>/Off

\*1: Default Setting

\*: Not available on all models

## Power Tailgate Setup

### Keyless Open Mode

Anytime<sup>\*1</sup>/When Unlocked

### Power Open By Outer Handle

On (Power/Manual)<sup>\*1</sup>/Off (Manual Only)

### Hands Free Access Function\*

On<sup>\*1</sup>/Off

\*1: Default Setting

## Climate Control Setup

### Driver Seat automatic Climate Control

On<sup>\*1</sup>/Off

### Passenger Seat automatic Climate Control

On<sup>\*1</sup>/Off

\*1: Default Setting

## INDIVIDUAL Settings

### Engine

COMFORT/NORMAL<sup>\*1</sup>/SPORT

### Steering

COMFORT/NORMAL<sup>\*1</sup>/SPORT

### Engine Sound

COMFORT/NORMAL<sup>\*1</sup>/SPORT

### Idle Stop

ENABLE<sup>\*1</sup>/DISABLE

### Gauge

COMFORT/NORMAL<sup>\*1</sup>/SPORT

\*1: Default Setting

## Maintenance Info.

Select Reset Items



## How to Customize the Profile Settings

You can add and change users, as well as customize user settings.

Press the  (Home) button, select **Profile Settings**, and select a setting item you want.

## Change Profile

You can change and add users.

 User Information  P.242

\*: Not available on all models

## Manage Profile

Use **Manage Profile** to change profile settings. Please confirm the details on the audio/information screen.

Specifications are subject to change via system updates, etc.

## Defaulting All the Settings

Reset all the menu and customized settings to their factory defaults.

- If you perform **Factory Data Reset**, it will reset the preinstalled apps to their factory default.
- If you perform **Factory Data Reset**, you cannot use AcuraLink® because it goes offline.

 AcuraLink® ▶ P.231





When you transfer the vehicle to a third-party, reset all settings to default and delete all personal data.

## Defaulting General Settings

Only the Owner user can execute.

If you are not the Owner user, please switch users.

 Switching Users ▶ P.244

- [1] Press the  (Home) button.
- [2] Select **General Settings**.
- [3] Select **System**.
- [4] Select **Factory Data Reset**.
  - » A confirmation message appears on the screen.
- [5] Select **Continue** to reset the settings.
- [6] Select **Continue** again to reset the settings.
  - » The system will reboot.

## Defaulting Vehicle Settings

- [1] Press the  (Home) button.
- [2] Select **Vehicle Settings**.
- [3] Select **Default All**.
- [4] Select **Yes**.

# General Information on the Audio System

## Compatible iPod, iPhone, and USB Flash Drives

The following information was made based on the most up-to-date information at the time this manual was written. There may be some discrepancies with updated versions of the audio system.

### iPod and iPhone Model Compatibility

#### ▼ Models with 9" Color Touchscreen

##### Model

Made for iPod touch (7th generation)

Made for iPhone 6s/iPhone 6s Plus/iPhone SE/iPhone 7/iPhone 7 Plus/iPhone 8/iPhone 8 Plus/iPhone X/iPhone XR/iPhone XS/iPhone XS Max/iPhone 11/iPhone 11 Pro/iPhone 11 Pro Max/iPhone SE (2nd generation)/iPhone 12 mini/iPhone 12/iPhone 12 Pro/iPhone 12 Pro Max/iPhone 13 mini/iPhone 13/iPhone 13 Pro/iPhone 13 Pro Max/iPhone SE (3rd generation)/iPhone 14/iPhone 14 Plus/iPhone 14 Pro/iPhone 14 Pro Max/iPhone 15/iPhone 15 Plus/iPhone 15 Pro/iPhone 15 Pro Max

#### ▼ Models with 9" Color Touchscreen with Google built-in

##### Model

Made for iPod touch (6th generation)/iPod touch (7th generation)

Made for iPhone 5s/iPhone 6/iPhone 6 Plus/iPhone 6s/iPhone 6s Plus/iPhone SE/iPhone 7/iPhone 7 Plus/iPhone 8/iPhone 8 Plus/iPhone X/iPhone XR/iPhone XS/iPhone XS Max/iPhone 11/iPhone 11 Pro/iPhone 11 Pro Max/iPhone SE (2nd generation)/iPhone 12 mini/iPhone 12/iPhone 12 Pro/iPhone 12 Pro Max/iPhone 13 mini/iPhone 13/iPhone 13 Pro/iPhone 13 Pro Max/iPhone SE (3rd generation)/iPhone 14/iPhone 14 Plus/iPhone 14 Pro/iPhone 14 Pro Max

This system may not work with all software versions of these devices.

### Compatible USB Flash Drives

Please use a recommended USB flash drive of 256MB or higher formatted with FAT16 or FAT32.

- Some digital audio players may not be compatible.
- Some USB flash drives (e.g., a device with security lockout) may not work.
- Some software files may not allow for audio play or text data display.
- Some versions of MP3, WMA, AAC, FLAC, WAV formats may be unsupported.

- Files on the USB flash drive are played in their stored order. This order may be different from the order displayed on your PC or device.
- Only AAC format files recorded with iTunes are playable on this unit.

## Honda App License Agreement

### END USER LICENSE AGREEMENT

PLEASE CAREFULLY READ THIS END USER LICENSE AGREEMENT (THIS “AGREEMENT”) WHICH GOVERNS YOUR USE OF THE SOFTWARE INSTALLED ON YOUR HONDA OR ACURA VEHICLE (YOUR “VEHICLE”) AS WELL AS THE APPLICATIONS, SERVICES, FUNCTIONS, AND CONTENT PROVIDED THROUGH THE SOFTWARE (COLLECTIVELY, THE “SERVICES”). YOUR USE OF THE SOFTWARE OR SERVICES WILL SERVE AS YOUR CONSENT TO THE TERMS OF THIS AGREEMENT. THE SOFTWARE IS OWNED (OR LICENSED), PROVIDED, AND/OR OPERATED BY AMERICAN HONDA MOTOR CO. INC., (“HONDA,” “US,” “WE,” OR “OUR”), WITH ITS BUSINESS ADDRESS AT 1919 TORRANCE BLVD., TORRANCE, CA 90501. REFERENCE TO “HONDA” IN THIS AGREEMENT INCLUDES HONDA’S PARENT COMPANY AND ITS AFFILIATES AND DESIGNATED AGENTS. THE SERVICES ARE OWNED (OR LICENSED), PROVIDED, AND/OR OPERATED BY HONDA OR A THIRD-PARTY SERVICE PROVIDER (A “PROVIDER”). REFERENCE TO A “PROVIDER” IN THIS AGREEMENT INCLUDES SUCH PROVIDER’S PARENT COMPANY, AFFILIATES, AND DESIGNATED AGENTS.

**A. Description of the Software.** The SOFTWARE includes the software, firmware and the like, installed and executing on your VEHICLE during manufacture, and thereafter updated from time to time by HONDA, you or an authorized HONDA dealer (a “DEALER”). The SOFTWARE allows you to access and use a variety of SERVICES, including but not limited to: (a) HONDA applications, services, and content provided through the SOFTWARE (together, “HONDA SERVICES”); and (b) PROVIDER applications, services, and content provided through the SOFTWARE (together, “PROVIDER SERVICES”), each of which may provide access to various information, media, content, and services.

**B. SOFTWARE Licensing and Intellectual Property.**

**1. SOFTWARE.** This AGREEMENT grants you a non-exclusive, limited, and revocable license to use the SOFTWARE and SERVICES solely (a) as installed on your VEHICLE by HONDA, (b) as updated on your Vehicle by HONDA, you (but only as and when directed by HONDA), or a DEALER and (c) as permitted under the terms of this AGREEMENT.

**2. HONDA Services.** The SOFTWARE may provide you with access to various HONDA SERVICES. Installation, activation, or use of HONDA SERVICES may require your consent to additional terms, conditions, and privacy policies applicable to those HONDA SERVICES (the “HONDA TERMS”). You acknowledge and agree that any collection, use, sharing of data generated by your VEHICLE or your use of your VEHICLE, and your use of the HONDA SERVICES shall be subject to this AGREEMENT and any additional HONDA TERMS that may be specifically applicable to such HONDA SERVICES or data generation. The HONDA SERVICES may collect, use, and share such data while you are using the SOFTWARE.

**3. Open-Source Software.** The SOFTWARE and SERVICES may incorporate software licensed to HONDA under free or open-source licenses which govern HONDA’s distribution and your use of such software. HONDA and the third-party authors, licensors, and distributors of such software disclaim all warranties and all liability arising from any and all use or distribution of the software. To the extent such software is provided under terms that differ from the applicable free or open-source licenses, those terms are offered by HONDA alone. Additional information regarding free and open-source software incorporated in the SOFTWARE and SERVICES is available in this manual or within the SOFTWARE.

**4. Provider Services.** The SOFTWARE may provide you with access to various PROVIDER SERVICES. Installation or use of such PROVIDER SERVICES may require your consent to additional terms, conditions, and privacy policies of the applicable PROVIDER (the “PROVIDER TERMS”). This AGREEMENT restricts the manner in which you can install and use PROVIDER SERVICES but does not grant you a license or permission to use such PROVIDER SERVICES. Your permission to use PROVIDER SERVICES is limited and subject to any license grants, conditions, and limitations included in the PROVIDER TERMS. You acknowledge that any collection, use, sharing of your information, targeted advertising practices by PROVIDERS, and your use of the PROVIDER SERVICES shall be subject to both this AGREEMENT and any applicable PROVIDER TERMS. The PROVIDER SERVICES may collect, use, and share such information while you are using the SOFTWARE.

## **5. License Limitations and Restrictions on Use.**

(a) Limited License. You understand and agree that the SOFTWARE and SERVICES are licensed, not sold, to you solely for use in accordance with this AGREEMENT and any applicable PROVIDER TERMS, and any documentation for the VEHICLE made available to you by HONDA (any “DOCUMENTATION”). HONDA and its licensors reserve all rights in the SOFTWARE and HONDA SERVICES not expressly granted to you under this AGREEMENT. PROVIDERS and their licensors reserve all rights in the PROVIDER SERVICES not expressly granted to you under the applicable PROVIDER TERMS.

(b) Restrictions on Use. The licenses granted under this AGREEMENT do not permit you to use the SOFTWARE or SERVICES on a device other than your VEHICLE. As a condition of using the SOFTWARE and SERVICES, you agree that you may not and will not:

- (1) copy, download, distribute, modify, publish, sell, rent, lease, lend, license, sublicense, reuse, or create derivative works of the SOFTWARE or SERVICES or any of the content or other material within the SOFTWARE or SERVICES, including without limitation, HONDA or PROVIDER names, logos, or any other trademarks of HONDA or PROVIDERS or used in association with the SOFTWARE or any SERVICES, except as required to use the SOFTWARE or SERVICES in accordance with this AGREEMENT, any applicable PROVIDER TERMS, and the DOCUMENTATION;
- (2) access or use the SOFTWARE or SERVICES in any manner intended to damage or impair the operation of the SOFTWARE or SERVICES or interfere with anyone else's use and enjoyment of the SOFTWARE or SERVICES;
- (3) access or attempt to access any system or server on which the SOFTWARE or SERVICES is hosted or modify or alter the SOFTWARE or SERVICES in any way;
- (4) use the SOFTWARE or SERVICES for any unlawful purpose, or in violation of any third party rights;
- (5) use the SOFTWARE or SERVICES in violation of any applicable traffic regulations, rules or laws, including but not limited to any driver distraction laws, rules or regulations;
- (6) violate the terms of this AGREEMENT, any HONDA TERMS, any PROVIDER TERMS or other applicable third-party terms, conditions, and privacy policies; or
- (7) reverse engineer, decompile, disassemble, attempt to derive the source code of, nor permit others to reverse engineer, decompile, or disassemble, or attempt to derive the source code of the SOFTWARE or SERVICES, except and only to the extent that such activity is expressly permitted (a) by applicable law notwithstanding this limitation or (b) the terms of applicable free or opensource software licenses.

**6. Intellectual Property Rights.** All title and intellectual property rights in and to the SOFTWARE and SERVICES, the accompanying DOCUMENTATION, and all copies of the SOFTWARE or SERVICES are owned by HONDA, PROVIDERS, or their suppliers or licensors. This AGREEMENT does not grant you any rights in connection with any trademarks or service marks of HONDA, PROVIDERS, or their licensors, affiliates, or suppliers.

**7. Export Restrictions:** You acknowledge that the SOFTWARE and SERVICES are subject to U.S., European Union, and other export jurisdictions. You agree to comply with all applicable international and national laws that apply to the SOFTWARE and SERVICES, including the U.S. Export Administration Regulations, as well as end-user, end-use, and destination restrictions issued by the U.S. and other governments.

### **C. SOFTWARE Operation**

**1.** HONDA reserves the right to suspend or terminate your access to and use of the SOFTWARE or SERVICES if you are found to be in violation of this AGREEMENT or as reasonably deemed necessary by HONDA.

**2. Eligibility/Registration/Activation.** The SOFTWARE is intended for and available to individuals who (a) are of legal age of majority in their jurisdiction of residence (and at least 18 years of age), or are younger than 18 years of age and possess a valid driver's license issued by their jurisdiction of residence, and (b) own or have permissive access to a compatible VEHICLE. We do not knowingly collect any information, including personal information, from children under 13. If we learn or are notified that we have collected personal information of a child under 13, we will immediately take steps to delete such information.

**3. Use of PROVIDER SERVICES through the SOFTWARE.** Certain PROVIDER SERVICES made available through the SOFTWARE may require that you register or otherwise have an account with the PROVIDER and agree to PROVIDER TERMS. Any use of any of such PROVIDER SERVICES within the SOFTWARE is subject to this AGREEMENT and the applicable PROVIDER TERMS. HONDA does not exercise control over such PROVIDER SERVICES and is not responsible or liable for the availability, security, or content of such PROVIDER SERVICES, and the inclusion of any PROVIDER SERVICES does not imply a referral from, the approval of, or the endorsement by HONDA of such PROVIDER SERVICES. HONDA is not responsible or liable, directly or indirectly, for any damage relating to or resulting from your use of the PROVIDER SERVICES.

**4. Links to Third Party Sites:** The SOFTWARE may provide you with the ability to access third-party sites and content through the use of the SOFTWARE or SERVICES. The third-party sites and content are not under the control of HONDA. HONDA is not responsible or liable, directly or indirectly, for such third-party websites and their content or for any damage relating to or resulting from your access or use of such websites and content.

**5. Unauthorized Use and Abuse.** You are responsible for ensuring your (and any authorized third parties') use of the SOFTWARE and SERVICES remains in compliance with this AGREEMENT and all other applicable HONDA TERMS and PROVIDER TERMS. You acknowledge and agree that any use of the SOFTWARE or SERVICES occurring through your VEHICLE will be deemed your actions and that HONDA and PROVIDERS may rely upon such actions. You agree to immediately notify us if you suspect fraudulent or abusive activity involving the SOFTWARE or SERVICES. If you so notify us or if we otherwise suspect fraudulent or abusive activity, you agree to cooperate with us in any fraud investigation and to use any fraud prevention measures we prescribe. Your failure to immediately notify us or cooperate to use such measures will result in your liability for all fraudulent usage or abusive activity associated with your VEHICLE.



**6. SOFTWARE Updates.** The SOFTWARE and SERVICES may be updated when your VEHICLE is serviced by a DEALER or remotely, over-the-air, by HONDA from time to time; such updates may occur with or without further notice or your future consent. The SOFTWARE may be updated at HONDA's discretion and for any purpose including, without limitation, to patch or otherwise improve the SOFTWARE or SERVICES functionality, security, or stability. All updates to the SOFTWARE and SERVICES are subject to this AGREEMENT and any other applicable HONDA TERMS and PROVIDER TERMS.

**7. Uninstalling, Removing, and Replacing the SOFTWARE.** Replacing SOFTWARE or HONDA SERVICES with software or firmware not provided and installed by HONDA or a DEALER will render all representations and warranties for the SOFTWARE, HONDA SERVICES, and VEHICLE functionality reliant upon the SOFTWARE or HONDA SERVICES null and void.

## **D. SOFTWARE Operational Notices and Warnings**

**1. Vehicle Geolocation Information.** You acknowledge that your VEHICLE may be equipped with certain traffic and map features. The traffic feature will automatically collect and transmit, through GPS technology, your Vehicle's current location (longitude and latitude), travel direction and speed ("VEHICLE GEOLOCATION INFORMATION") to HONDA and PROVIDERS. The VEHICLE GEOLOCATION INFORMATION is used by HONDA and PROVIDERS to provide traffic and navigation-related information to you, but may also be used to provide other SERVICES or offers to you. HONDA will not use such VEHICLE GEOLOCATION INFORMATION for its own marketing efforts, or provide such information to unaffiliated third parties for their own purposes, without your express consent.

**2. Potential Map Inaccuracy and Route Safety.** Maps used by this system may be inaccurate because of changes in roads, traffic controls, routing, or driving conditions. Always use good judgment and common sense when following suggested routes. Do not follow the route suggestions if doing so would result in an unsafe or illegal driving maneuver, if you would be placed in an unsafe situation, or if you would be directed into an area that you consider unsafe. Do not rely on any navigation features included in the system to route you to emergency services. Not all emergency services such as police, fire stations, hospitals, or clinics are likely to be contained in the map database for such navigation features. Ask local authorities or an emergency services operator for such locations and routes. The driver is ultimately responsible for the safe operation of the vehicle and therefore, must evaluate whether it is safe to follow the suggested directions. Any navigation features are provided only as an aid. Make your driving decisions based on your observations of local conditions and existing traffic regulations. Navigation features are not a substitute for your personal judgment. Any route suggestions made by the SOFTWARE or SERVICES should never replace any local traffic regulations or your personal judgment or knowledge of safe driving practices.

**3. Speech Recognition:** You acknowledge and understand that HONDA and PROVIDERS may record, retain, and use voices commands when you use the speech recognition components of the SOFTWARE or SERVICES. You and all VEHICLE operators and passengers (a) consent to the recording and retention of voice commands in support of providing speech recognition components and (b) release HONDA and PROVIDERS from all claims, liabilities, and losses that may result from any use of such recorded voice commands. Recognition errors are inherent in speech recognition. It is your responsibility to monitor any speech recognition functions included in the system and address any errors. Neither HONDA nor PROVIDERS will be liable for any damages arising out of errors in the speech recognition process.

**4. Distraction Hazards:** Navigation features may require manual (non-verbal) input or setup. Attempting to perform such set-up or insert data while driving can seriously distract your attention and could cause a crash or other serious consequences; the ability to undertake such interactions may also be limited by state or local law, which laws you are responsible to know and follow. Even occasional short scans of the screen may be hazardous if your attention has been diverted away from your driving at a critical time. Pull over and stop the vehicle in a safe and legal manner before attempting to access a function of the system requiring prolonged attention. Do not raise the volume excessively. Keep the volume at a level where you can still hear outside traffic and emergency signals while driving. Driving while unable to hear these sounds could result in a crash.

## **E. Information Collection and Storage**

**1. Information Collection, Use, Transmission and Storage of Data.** Consent to Use of Data: You agree that HONDA and PROVIDERS may collect and use your information gathered in any manner as part of product support services related to the SOFTWARE or related services. HONDA may share such information with third parties, including, without limitation, PROVIDERS, third party software and services suppliers, their affiliates and/or their designated agents, solely to improve their products or to provide services or technologies to you. HONDA, third party software and systems suppliers, their affiliates and/or their designated agent may disclose this information to others, but not in a form that personally identifies you.

**2. Information Storage.** Depending on the type of multimedia system you have in your VEHICLE, certain information may be stored for ease of use of the SOFTWARE including, without limitation, search history, location history in certain applications, previous and saved destinations, map locations within certain applications, and device numbers and contact information.

(a) Vehicle Health Information. Your VEHICLE may remotely transmit information regarding the status and health of your VEHICLE (“VEHICLE INFORMATION”) to HONDA without notification to you. VEHICLE INFORMATION may contain VEHICLE maintenance and malfunction status that is derived from VEHICLE diagnostic data and includes, but is not limited to, status of powered doors and windows, battery life data, battery charging data, VEHICLE speed, coolant temperature, air compressor revolution, output power, warning codes, diagnostic trouble codes, fuel injection volume, and engine rotations per minute. VEHICLE HEALTH INFORMATION may be used by HONDA for research and development, to deliver HONDA SERVICES and information to you, and to contact you, and is retained only for a period of time necessary to fulfill these goals.

(b) VEHICLE Geolocation Data (non-navigation/map based). If you opt-in to geolocation-based SERVICES, your vehicle’s geolocation data (latitude and longitude) will be automatically sent from your VEHICLE to HONDA and PROVIDERS.

(c) You understand that the inputting or uploading of information to your VEHICLE’s multimedia system or the SOFTWARE or SERVICES is at your own risk and that HONDA is not responsible for unauthorized access to or use of any personal or other information. All information uploaded to the SOFTWARE and SERVICES may be stored on your VEHICLES’s multimedia system and you understand that the security and safety of your VEHICLE’s multimedia system is your sole responsibility.

**F. NO WARRANTY.** You understand and agree that your use of the SOFTWARE and SERVICES are solely at your own risk and that you will be solely responsible for any damage to your VEHICLE's multimedia system or any other equipment or any loss of data that may result from your use of the SOFTWARE or SERVICES. THE SOFTWARE AND SERVICES ARE PROVIDED ON AN "AS IS" AND "AS AVAILABLE" BASIS WITHOUT ANY WARRANTY OF ANY KIND, EXPRESSED, IMPLIED OR STATUTORY. WE SPECIFICALLY DISCLAIM ANY IMPLIED WARRANTIES OF MERCHANTABILITY, FITNESS FOR A PARTICULAR PURPOSE, AND NON-INFRINGEMENT. HONDA makes no warranties that the SOFTWARE or SERVICES will meet your requirements, or that the SOFTWARE or SERVICES will be uninterrupted, timely, secure, non-infringing or error free. You understand and agree that you are responsible for any and all charges, costs or expenses associated with your use of the SOFTWARE or SERVICES. Advice or information, whether oral or written, obtained by you from us or through the SOFTWARE or SERVICES are provided for informational purposes only and will not create any warranty not expressly made herein. You should not rely on any such information or advice. We assume no liability or responsibility for any errors or omissions in the SOFTWARE or SERVICES. We do not make any warranty or representation that your use of the material displayed on, or obtained through, the SOFTWARE or SERVICES is non-infringing of any rights of any third party. Any decision or action taken by you on the basis of information or content provided via the application is at your sole discretion and risk. HONDA and PROVIDERS are not responsible or liable for any such decision, or for the accuracy, completeness, usefulness, or availability of any content or information displayed, transmitted, or otherwise made available via the SOFTWARE or SERVICES. To the extent jurisdictions do not allow the exclusion of certain warranties, some of the above exclusions may not apply to you.

**G. LIMITATIONS ON LIABILITY.** You and HONDA are each waiving important rights.

**1. Limitations on YOUR liability.** HONDA cannot recover from you any consequential, indirect, incidental, or special damages, or attorney's fees in connection with your use of the SOFTWARE or HONDA SERVICES. HONDA WAIVES TO THE FULLEST EXTENT ALLOWED BY LAW ANY CLAIM FOR DAMAGES OTHER THAN DIRECT, COMPENSATORY DAMAGES AS LIMITED IN THIS AGREEMENT.

**2. Limitation on HONDA and PROVIDER liability.** Neither HONDA nor PROVIDERS will be liable to you or any other party for consequential, indirect, incidental, special, or punitive damages (including without limitation lost profits) in connection with your use of the SOFTWARE or SERVICES, even if HONDA or PROVIDERS are aware of the possibility of such damages. These limitations apply to all claims, including, without limitation, claims in contract and tort (such as negligence, product liability and strict liability). To the extent that a jurisdiction does not permit the exclusion or limitation of liability as set forth herein our liability is limited to the maximum extent permitted by law in such states. If HONDA or PROVIDERS are found liable to you for any reason, you agree that the aggregate liability of all these parties to you for any claim is limited to ten U.S. dollars (US \$10.00). Neither HONDA nor any PROVIDER would have agreed to provide the SOFTWARE or SERVICES to you if you did not agree to this limitation. This amount is the sole and exclusive liability of HONDA and PROVIDERS to you, and is payable as liquidated damages and not as a penalty. Except where prohibited by law, you may not bring any claim against HONDA or any third-party beneficiary more than two (2) years after the claim arises. We do not have any liability for SOFTWARE or SERVICES interruptions of any length.

(a) **Release of HONDA and PROVIDERS** For yourself and anyone else claiming under you, you agree to release and discharge HONDA, PROVIDERS, their respective officers, directors, and employees, and each third-party beneficiary from all claims, liabilities and losses in connection with the SOFTWARE or SERVICES, including, but not limited to claims for personal injury or property damage arising from the total or partial failure of performance of the SOFTWARE or SERVICES, even if caused by or based upon the negligence, gross negligence, strict products liability, Deceptive Trade Practices Act violations, bad faith, or breach of warranty of us or the malfunction of the SOFTWARE or SOFTWARE SERVICES. YOU AGREE TO WAIVE TO THE FULLEST EXTENT ALLOWED BY LAW, ANY CLAIM FOR DAMAGES OTHER THAN DIRECT, COMPENSATORY DAMAGES AS LIMITED IN THIS AGREEMENT. YOU HEREBY RELEASE AND DISCHARGE HONDA AND ITS LICENSORS AND CONTRACTORS (INCLUDING ANY THIRD PARTIES PROVIDING ALL OR PART OF THE SOFTWARE OR SERVICES) FROM AND AGAINST ANY CLAIMS, DAMAGES, EXPENSES AND LIABILITY ARISING FROM OR RELATED TO ANY INJURIES, DAMAGES, OR LOSSES TO ANY PERSON (INCLUDING DEATH) OR PROPERTY OF ANY KIND RESULTING IN WHOLE OR PART, DIRECTLY OR INDIRECTLY, FROM YOUR USE OF THE SOFTWARE OR SERVICES.

**H. Survival.** You agree that the limitations of liability and indemnities in this AGREEMENT will survive even after the AGREEMENT has ended. These limitations of liability apply not only to you, but to anyone using the SOFTWARE or SERVICES via your VEHICLE, to anyone making a claim on your behalf, and to any claims made by your family, employees, customers, or others arising out of or relating to your VEHICLE, the SOFTWARE, or SERVICES.

**I. Availability/Interruption.** The SOFTWARE and certain SERVICES are made available through your VEHICLE's compatible multimedia system when the VEHICLE is turned on. Certain SERVICES may be available only through your compatible mobile device when it is within the operating range of the VEHICLE and a wireless carrier. The availability of the SOFTWARE and SERVICES may be subject to transmission limitation or interruption, including but not limited to technical obsolescence or sunsetting of the hardware, software or firmware, inside of or external to the Vehicle, required for data transmission or receipt. HONDA does not guarantee that the SOFTWARE, SERVICES, or any portion thereof will be available at all times or in all areas. You acknowledge and agree that HONDA is not responsible for performance degradation, interruption or delays. You acknowledge that HONDA shall not be liable to you if the SOFTWARE or SERVICES in a given location are not available. If the SOFTWARE or SERVICES are not available within your intended location, you agree that your sole remedy shall be to cease using the SOFTWARE and SERVICES.

**J. PRODUCT SUPPORT:** Product support for the SOFTWARE is provided by HONDA. For product support, please refer to HONDA instructions provided in the DOCUMENTATION. Should you have any questions concerning this AGREEMENT, or if you desire to contact HONDA for any other reason, please refer to the HONDA contact information provided in the DOCUMENTATION.

**K. Termination and Transfer.**

**1. Termination.** This AGREEMENT is effective until terminated by you or US. WE may terminate this AGREEMENT for any or no reason, and with or without notice to you. Your rights under this AGREEMENT will terminate automatically without notice from US if you fail to comply with any term of this AGREEMENT. Upon termination of this AGREEMENT, you shall cease all use of the SOFTWARE and SERVICES.

**2. Transfer:** You may permanently transfer your rights under this AGREEMENT only as part of a sale or transfer of the VEHICLE, provided you retain no copies, you transfer all of the SOFTWARE and HONDA SERVICES (including all component parts, the media and printed materials, and any upgrades), and the recipient agrees to the terms of this AGREEMENT. You agree to notify HONDA upon the sale or transfer of the VEHICLE. To contact HONDA, please refer to the HONDA contact information provided in the DOCUMENTATION.

**L. Changes to the SOFTWARE or SERVICES.** WE may change, modify, or update the SOFTWARE or SERVICES from time to time. Unless explicitly stated otherwise, any new features or services that augment or enhance the SOFTWARE or SERVICES in the future shall respectively be considered part of the SOFTWARE or SERVICES and subject to this AGREEMENT. WE reserve the right at any time and from time to time to interrupt, restrict, modify, suspend, discontinue, temporarily or permanently, the SOFTWARE or SERVICES (or any portion thereof), with or without notice to you, and you agree that HONDA shall not be liable to you or to any third party for any modification, suspension or discontinuance of the SOFTWARE or SERVICES.

**M. ARBITRATION:**

PLEASE READ THIS ARBITRATION PROVISION CAREFULLY TO UNDERSTAND YOUR RIGHTS. YOU AGREE THAT ANY CLAIM THAT YOU MAY HAVE IN THE FUTURE MUST BE RESOLVED THROUGH BINDING ARBITRATION. YOU WAIVE THE RIGHT TO HAVE YOUR DISPUTE HEARD IN COURT AND WAIVE THE RIGHT TO BRING CLASS CLAIMS. YOU UNDERSTAND THAT DISCOVERY AND APPEAL RIGHTS ARE MORE LIMITED IN ARBITRATION.

Arbitration is a method of resolving a claim, dispute or controversy without filing a lawsuit. By agreeing to arbitrate, the right to go to court is waived and instead claims, disputes or controversies are submitted to binding arbitration. This provision sets forth the terms and conditions of our agreement. YOU and HONDA agree and acknowledge that this Agreement affects interstate commerce and the Federal Arbitration Act ("FAA") applies. By using the Software, Vehicle, or Services, YOU elect to have disputes resolved by arbitration. YOU, HONDA or any involved third party may pursue a Claim. "Claim" means any dispute between YOU, HONDA, or any involved third party relating to your use of the Software, the Vehicle, or the Services, this Agreement, or our relationship, including any representations, omissions or warranties. "Claim" does not include personal injury or wrongful death claims. YOU or HONDA may seek remedies in small claims court or provisional judicial remedies without arbitrating. In addition, notwithstanding anything herein to the contrary, YOU or HONDA may seek equitable relief in a court of competent jurisdiction.

YOU or HONDA may select arbitration with American Arbitration Association, JAMS or National Arbitration and Mediation. Contact these sponsors for their rules. The hearing will be in the federal district where YOU reside. If agreed, it may be by telephone or written submissions. Filing and arbitrator fees to be paid per the sponsor rules. You may contact the sponsor for a fee waiver. If no fee waivers, HONDA will pay filing and arbitrator fees up to \$5,000, unless law requires more. Each party is responsible for other fees. Arbitrator may award costs or fees to prevailing party, if permitted by law. HONDA will not seek fees, unless the claims are frivolous.

Arbitrator shall be an attorney or current or retired judge familiar with automotive or consumer software. The arbitrator shall follow substantive law, statute of limitations and decide all issues relating to the interpretation, construction, enforceability and applicability of this provision. The arbitrator may order relief permitted by law. This provision is governed and enforceable by the FAA. An award shall include a written opinion and be final, subject to appeal by the FAA.

This provision survives termination of this Agreement or relationship, bankruptcy, assignment or transfer. If part of this provision is unenforceable, the remainder remains in effect. If unenforceability allows arbitration as a class action, then this provision is entirely unenforceable. You may opt out within 30 days of your initial use of the Software by sending a signed, written notice to Acura at American Honda Motor Co., Inc. Acura Client Relations Mail Stop CHI-4, 1919 Torrance Blvd. Torrance, CA 90501-2746. HONDA reserves the right to make changes to this provision after providing written notice and an opportunity to opt out.

**N. Miscellaneous:** You may not assign this AGREEMENT without HONDA's prior written consent. This AGREEMENT and any additional HONDA TERMS and PROVIDER TERMS represents the entire agreement between you and US. HONDA may amend the terms of this AGREEMENT by providing you with notices of such updated terms. If you do not consent to be bound by the updated terms, your sole remedy will be to cease using the SOFTWARE and SERVICES. If any part of this AGREEMENT is found invalid, void, or unenforceable, the balance of the AGREEMENT will remain valid and enforceable according to its terms. To the fullest extent permitted by law, and except as explicitly provided otherwise, this AGREEMENT and any disputes arising out of or relating to it will be governed by the laws of the State of California, except that California laws concerning choice of law or conflicts shall not apply if they would cause the substantive law of another jurisdiction to apply. Notwithstanding the foregoing, Section M shall be governed by the Federal Arbitration Act and the laws of the State of California, as applicable, as set forth therein. The failure to enforce any term of this AGREEMENT on one occasion shall not prevent enforcement on any other occasion or the enforcement of any other term. Headings and captions shall not be considered included for purposes of interpretation or application hereof, but are for convenience only.

## About Open Source Licenses

To see the open source license information, follow these steps.

### ▼ Models with 9" Color Touchscreen with Google built-in

- [1] Press the  (Home) button.
- [2] Select **General Settings**.
- [3] Select **Advanced Settings**.
- [4] Select **System**.
- [5] Select **Legal Information**.
- [6] Select **System WebView licenses**.

### ▼ Models with 9" Color Touchscreen

- [1] Press the  (Home) button.
- [2] Select **General Settings**.
- [3] Select **System**.
- [4] Select **Legal Information**.



## License Information

### Bluetooth®

The *Bluetooth*® word mark and logos are registered trademarks owned by Bluetooth SIG, Inc. and any use of such marks by ALPS ALPINE CO., LTD. is under license. Other trademarks and trade names are those of their respective owners.

The *Bluetooth*® word mark and logos are registered trademarks owned by Bluetooth SIG, Inc. and any use of such marks by Faurecia Clarion Electronics Co., Ltd. is under license. Other trademarks and trade names are those of their respective owners.  
<https://www.bluetooth.com/develop-with-bluetooth/marketing-branding/>



### Windows Media

This product is protected by certain intellectual property rights of Microsoft. Use or distribution of such technology outside of this product is prohibited without a license from Microsoft.

### Apple

“Made for iPod,” and “Made for iPhone,” mean that an electronic accessory has been designed to connect specifically to iPod, or iPhone, respectively, and has been certified by the developer to meet Apple performance standards. Apple is not responsible for the operation of this device or its compliance with safety and regulatory standards. Please note that the use of this accessory with iPod, or iPhone, may affect wireless performance.

Apple, the Apple Logo, iPhone, iPod touch are trademarks of Apple Inc., registered in the U.S. and other countries. Apple CarPlay, iPod, iPhone, iTunes, Siri and Lightning are trademarks of Apple Inc. App Store is a service mark of Apple Inc.



### MPEG

Mpeg4 Visual

THIS PRODUCT IS LICENSED UNDER THE MPEG-4 VISUAL PATENT PORTFOLIO LICENSE FOR THE PERSONAL AND NON-COMMERCIAL USE OF A CONSUMER FOR (i) ENCODING VIDEO IN COMPLIANCE WITH THE MPEG-4 VISUAL STANDARD (“MPEG-4 VIDEO”) AND/OR (ii) DECODING MPEG-4 VIDEO THAT WAS ENCODED BY A CONSUMER ENGAGED IN A PERSONAL AND NONCOMMERCIAL ACTIVITY AND/OR WAS OBTAINED FROM A VIDEO PROVIDER LICENSED BY MPEG LA TO PROVIDE MPEG-4 VIDEO. NO LICENSE IS GRANTED OR SHALL BE IMPLIED FOR ANY OTHER USE. ADDITIONAL INFORMATION INCLUDING THAT RELATING TO PROMOTIONAL, INTERNAL AND COMMERCIAL USES AND LICENSING MAY BE OBTAINED FROM MPEG LA, LLC. SEE [HTTP://WWW.MPEGLA.COM](http://www.mpegla.com).

AVC/H.264

THIS PRODUCT IS LICENSED UNDER THE AVC PATENT PORTFOLIO LICENSE FOR THE PERSONAL AND NONCOMMERCIAL USE OF A CONSUMER TO (i) ENCODE VIDEO IN COMPLIANCE WITH THE AVC STANDARD (“AVC VIDEO”) AND/OR (ii) DECODE AVC VIDEO THAT WAS ENCODED BY A CONSUMER ENGAGED IN A PERSONAL AND NON-COMMERCIAL ACTIVITY AND/OR WAS OBTAINED FROM A VIDEO PROVIDER LICENSED TO PROVIDE AVC VIDEO. NO LICENSE IS GRANTED OR SHALL BE IMPLIED FOR ANY OTHER USE. ADDITIONAL INFORMATION MAY BE OBTAINED FROM MPEG LA, L.L.C. SEE [HTTP://WWW.MPEGLA.COM](http://www.mpegla.com).

## HD Radio™

---

HD Radio™ Technology manufactured under license from iBiquity Digital Corporation, a subsidiary of Xperi Inc., U.S. and Foreign Patents. For patents see <https://xperi.com/hd-radio-patents/>. Xperi, HD Radio, HD, and ‘ARC’ logos and their respective logos are trademarks or registered trademarks of Xperi Inc. and its subsidiaries in the United States and other countries.



## Legal Information on Apple CarPlay/Android Auto

### OWNER'S MANUAL LICENSE/LIABILITY STATEMENTS

USE OF APPLE CARPLAY IS SUBJECT TO YOUR AGREEMENT TO THE CARPLAY TERMS OF USE, WHICH ARE INCLUDED AS PART OF THE APPLE iOS TERMS OF USE. IN SUMMARY, THE CARPLAY TERMS OF USE DISCLAIM APPLE AND ITS SERVICE PROVIDERS' LIABILITY IF THE SERVICES FAIL TO PERFORM CORRECTLY OR ARE DISCONTINUED, STRICTLY LIMIT APPLE AND ITS SERVICE PROVIDERS' OTHER LIABILITIES, DESCRIBE THE KINDS OF USER INFORMATION (INCLUDING, FOR EXAMPLE, VEHICLE LOCATION, VEHICLE SPEED, AND VEHICLE STATUS) BEING GATHERED AND STORED BY APPLE AND ITS SERVICE PROVIDERS, AND DISCLOSE CERTAIN POSSIBLE RISKS ASSOCIATED WITH THE USE OF CARPLAY, INCLUDING THE POTENTIAL FOR DRIVER DISTRACTION. SEE APPLE'S PRIVACY POLICY FOR DETAILS REGARDING APPLE'S USE AND HANDLING OF DATA UPLOADED BY CARPLAY.

USE OF ANDROID AUTO IS SUBJECT TO YOUR AGREEMENT TO THE ANDROID AUTO TERMS OF USE WHICH MUST BE AGREED TO WHEN THE ANDROID AUTO APPLICATION IS DOWNLOADED TO YOUR ANDROID PHONE. IN SUMMARY, THE ANDROID AUTO TERMS OF USE DISCLAIM GOOGLE AND ITS SERVICE PROVIDERS' LIABILITY IF THE SERVICES FAIL TO PERFORM CORRECTLY OR ARE DISCONTINUED, STRICTLY LIMIT GOOGLE AND ITS SERVICE PROVIDERS' OTHER LIABILITIES, DESCRIBE THE KINDS OF USER INFORMATION (INCLUDING, FOR EXAMPLE, VEHICLE LOCATION, VEHICLE SPEED, AND VEHICLE STATUS) BEING GATHERED AND STORED BY GOOGLE AND ITS SERVICE PROVIDERS, AND DISCLOSE CERTAIN POSSIBLE RISKS ASSOCIATED WITH THE USE OF ANDROID AUTO, INCLUDING THE POTENTIAL FOR DRIVER DISTRACTION. SEE GOOGLE'S PRIVACY POLICY FOR DETAILS REGARDING GOOGLE'S USE AND HANDLING OF DATA UPLOADED BY ANDROID AUTO.

## **DISCLAIMER OF WARRANTIES; LIMITATION ON LIABILITY**

YOU EXPRESSLY ACKNOWLEDGE AND AGREE THAT USE OF APPLE CARPLAY OR ANDROID AUTO (“THE APPLICATIONS”) IS AT YOUR SOLE RISK AND THAT THE ENTIRE RISK AS TO SATISFACTORY QUALITY, PERFORMANCE, ACCURACY AND EFFORT IS WITH YOU TO THE MAXIMUM EXTENT PERMITTED BY APPLICABLE LAW, AND THAT THE APPLICATIONS AND INFORMATION ON THE APPLICATIONS IS PROVIDED “AS IS” AND “AS AVAILABLE,” WITH ALL FAULTS AND WITHOUT WARRANTY OF ANY KIND, AND HONDA HEREBY DISCLAIMS ALL WARRANTIES AND CONDITIONS WITH RESPECT TO THE APPLICATIONS AND INFORMATION ON THE APPLICATIONS, EITHER EXPRESS, IMPLIED OR STATUTORY, INCLUDING, BUT NOT LIMITED TO, THE IMPLIED WARRANTIES AND/OR CONDITIONS OF MERCHANTABILITY, SATISFACTORY QUALITY, FITNESS FOR A PARTICULAR PURPOSE, ACCURACY, QUIET ENJOYMENT, AND NONINFRINGEMENT OF THIRD PARTY RIGHTS. NO ORAL OR WRITTEN INFORMATION OR ADVICE GIVEN BY HONDA OR AN AUTHORIZED REPRESENTATIVE SHALL CREATE A WARRANTY. AS EXAMPLES, AND WITHOUT LIMITATION, HONDA DISCLAIMS ANY WARRANTY REGARDING THE ACCURACY OF DATA PROVIDED BY THE APPLICATIONS, SUCH AS THE ACCURACY OF DIRECTIONS, ESTIMATED TRAVEL TIME, SPEED LIMITS, ROAD CONDITIONS, NEWS, WEATHER, TRAFFIC, OR OTHER CONTENT PROVIDED BY APPLE, GOOGLE, THEIR AFFILIATES, OR THIRD PARTY PROVIDERS; HONDA DOES NOT GUARANTEE AGAINST LOSS OF APPLICATION DATA, WHICH MAY BE LOST AT ANY TIME; HONDA DOES NOT GUARANTEE THAT THE APPLICATIONS OR ANY SERVICES PROVIDED THROUGH THEM WILL BE PROVIDED AT ALL TIMES OR THAT ANY OR ALL SERVICES WILL BE AVAILABLE AT ANY PARTICULAR TIME OR LOCATION. FOR EXAMPLE, SERVICES MAY BE SUSPENDED OR INTERRUPTED WITHOUT NOTICE FOR REPAIR, MAINTENANCE, SECURITY FIXES, UPDATES, ETC., SERVICES MAY BE UNAVAILABLE IN YOUR AREA OR LOCATION, ETC. IN ADDITION, YOU UNDERSTAND THAT CHANGES IN THIRD PARTY TECHNOLOGY OR GOVERNMENT REGULATION MAY RENDER THE SERVICES AND/OR APPLICATIONS OBSOLETE AND/OR UNUSABLE.

TO THE EXTENT NOT PROHIBITED BY LAW, IN NO EVENT SHALL HONDA OR ITS AFFILIATES BE LIABLE FOR PERSONAL INJURY, OR ANY INCIDENTAL, SPECIAL, INDIRECT OR CONSEQUENTIAL DAMAGES WHATSOEVER, INCLUDING, WITHOUT LIMITATION, DAMAGES FOR LOSS OF PROFITS, CORRUPTION OR LOSS OF DATA, FAILURE TO TRANSMIT OR RECEIVE ANY DATA, BUSINESS INTERRUPTION OR ANY OTHER COMMERCIAL DAMAGES OR LOSSES, ARISING OUT OF OR RELATED TO THE APPLICATIONS OR YOUR USE OF OR INABILITY TO USE THE APPLICATIONS OR INFORMATION ON THE APPLICATIONS, HOWEVER CAUSED, REGARDLESS OF THE THEORY OF LIABILITY (CONTRACT, TORT OR OTHERWISE) AND EVEN IF HONDA WERE ADVISED OF THE POSSIBILITY OF SUCH DAMAGES. SOME STATES AND JURISDICTIONS DISALLOW THE EXCLUSION OR LIMITATION OF LIABILITY FOR DAMAGES, SO THESE LIMITATIONS AND EXCLUSIONS MAY NOT APPLY TO YOU. IN NO EVENT SHALL HONDA'S TOTAL LIABILITY TO YOU FOR ALL DAMAGES (OTHER THAN AS MAY BE REQUIRED BY APPLICABLE LAW IN CASES INVOLVING PERSONAL INJURY) EXCEED THE AMOUNT OF FIVE DOLLARS (\$5.00). THE FOREGOING LIMITATIONS WILL APPLY EVEN IF THE ABOVE STATED REMEDY FAILS OF ITS ESSENTIAL PURPOSE.

# Safety Driving Assist System

## **AcuraWatch™**

About AcuraWatch™	278
Device for Operating Each Function and Gauge Content	279
Front Wide View Camera	280
Sonar Sensors*	281

## **Collision Mitigation Braking System™ (CMBS™)**

About CMBS™	284
System Operation	284
Operating Conditions	285
CMBS™ On and Off	286
CMBS™ Limitations	287

## **Low Speed Braking Control\***

About Low Speed Braking Control	291
System Operation	292
Low Speed Braking Control System On and Off	293
Low Speed Braking Control System Limitations	294

## **Road Departure Mitigation System**

About Road Departure Mitigation System	296
System Operation	296
Operating Conditions	297
Road Departure Mitigation System On and Off	297
Road Departure Mitigation System Limitations	297

## **Adaptive Cruise Control (ACC) with Low Speed Follow**

About ACC with Low Speed Follow	300
How to Activate ACC with Low Speed Follow	301
To Switch the Cruise Mode	306
ACC with Low Speed Follow Limitations	307

## **Lane Keeping Assist System (LKAS)**

About LKAS	310
Operating Conditions	311

How to Activate LKAS	311
LKAS Limitations	312

## **Traffic Jam Assist**

About Traffic Jam Assist	314
Operating Conditions	315
How to Activate Traffic Jam Assist	316
Traffic Jam Assist Limitations	317

## **Traffic Sign Recognition System**

About Traffic Sign Recognition System	319
Operating Conditions	320
Traffic Sign Recognition System Limitations	320

## **Blind Spot Information System**

About Blind Spot Information System	323
System Operation	323
Blind Spot Information System On and Off	324
Blind Spot Information System Limitations	324

## **Cross Traffic Monitor**

About Cross Traffic Monitor	326
System Operation	326
About Screen Display	327
Cross Traffic Monitor On and Off	328
Cross Traffic Monitor Limitations	328

## **Parking Sensor System\***

About Parking Sensor System	330
The Sensor Location and Range	330
Parking Sensor System On and Off	330
Screen Operation	331
Operations When an Obstacle Has Been Detected	331
Parking Sensor System Limitations	332

\*: Not available on all models

# AcuraWatch™

## About AcuraWatch™

Assists with functions such as acceleration, braking, and steering in order to reduce the burden on the driver, as well as help avoid or reduce the severity of collisions.

AcuraWatch™ has the following functions:

- Q Collision Mitigation Braking System™ (CMBS™) ▶ P.284
- Q Low Speed Braking Control ▶ P.291
- Q Road Departure Mitigation System ▶ P.296
- Q Adaptive Cruise Control (ACC) with Low Speed Follow ▶ P.300
- Q Lane Keeping Assist System (LKAS) ▶ P.310
- Q Traffic Jam Assist ▶ P.314
- Q Traffic Sign Recognition System ▶ P.319
- Q Auto High-Beam ▶ P.141
- Q Blind Spot Information System ▶ P.323
- Q Cross Traffic Monitor ▶ P.326
- Q Parking Sensor System\* ▶ P.330
- Q Driver Attention Monitor ▶ P.348

### WARNING

Only use AcuraWatch™ as a driving assistance system. AcuraWatch™ is not an autonomous driving system. This is only a system to assist the driver.

There are limits to the recognition and control capabilities of each of its functions.

Overreliance on the system may lead to accidents such as collisions, which may result in death or serious injury. Always check your surroundings and drive safely by maintaining a sufficient following distance.

-  If you set the power mode to ON while the vehicle is moving, such as when on a turntable in a parking lot, some functions may not work.

\*: Not available on all models



- To ensure proper operation of the system, observe the following:
- All the tires are of the same specified size, type, and brand, and that they are evenly worn.
  - Do not modify the suspension.

## Device for Operating Each Function and Gauge Content

### Operating Device



#### 1 ACC with Low Speed Follow Button

Press to activate standby mode for ACC with Low Speed Follow. Or, press to cancel the system.

#### 2 LKAS Button

Press to activate standby mode for LKAS and Traffic Jam Assist. Or, press to cancel the system.

#### 3 **RES/+ / SET/-** Switch

Press the **RES/+ / SET/-** switch up to set or resume the ACC with Low Speed Follow or increase the vehicle speed.

Press the **RES/+ / SET/-** switch down to set the ACC with Low Speed Follow or decrease the vehicle speed.

#### 4 Interval Button

Press to change the ACC with Low Speed Follow following-interval.

#### 5 **CANCEL** Button

Press to cancel ACC with Low Speed Follow.

### Gauge Content

You can see the current state of each function.



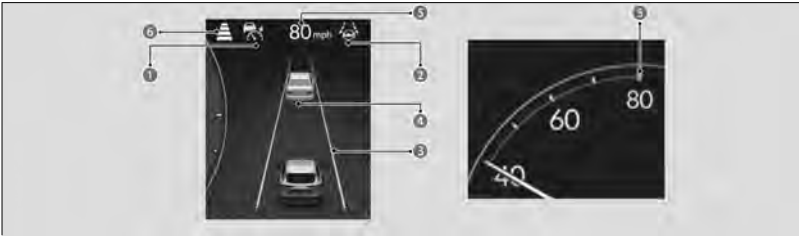

**1** Indicates that ACC with Low Speed Follow is ready to be activated.

- Green, White/Green: The system is on.  
» White/Green indicates that a vehicle is not detected ahead.
- White: The system is standby.
- Amber: There is a problem with the system.

**2** Indicates that LKAS or Traffic Jam Assist is ready to be activated.

- Green: The system is operating.
- White: The system is standby.
- Amber: There is a problem with the system.

**3** Indicates that LKAS or Traffic Jam Assist is activated and whether or not traffic lane lines are detected.

- Green Lines: The system is operating.
- White Lines: Traffic lane lines are detected.
- Amber Line: Lane departure is detected.

**4** Indicates whether or not a vehicle is detected ahead.

- Control target vehicle: White and outlined in green.
- Outside of control target vehicle: Gray.

**5** Indicates that ACC with Low Speed Follow shows the set vehicle speed.

**6** Indicates that ACC with Low Speed Follow shows the set vehicle interval.

## Front Wide View Camera



The front wide view camera (1) is located behind the rearview mirror.

## Handling of the Camera

- Avoid high interior temperatures to prevent the camera's sensing system from shutting off.
  - » It is recommended to find a shady area or face the front of the vehicle away from the sun when parking.
- To avoid concentrating heat on the camera, do not cover the camera when using a reflective sun shade.
- Never apply a film or attach any objects to the windshield, the hood, or the front grille that could obstruct the camera's field of vision and cause the system to operate abnormally.
- Do not scratch, nick, or cause any other damage to the windshield.
  - » Damage within the camera's field of vision can cause the system to operate abnormally. If this occurs, we recommend that you replace the windshield with a Genuine Acura replacement windshield.
  - » After replacing the windshield, have a dealer recalibrate the camera. Proper calibration of the camera is necessary for the system to operate properly.
  - » Making even minor repairs within the camera's field of vision or installing an aftermarket replacement windshield may also cause the system to operate abnormally.
- Do not place an object on the top of the instrument panel.
  - » It may reflect onto the windshield and prevent the system from detecting lane lines properly.
- Do not install anything on the hood or front grille that obstructs the camera's view.

If the **Some driver assist systems cannot operate: Camera temperature too high** message appears:

- Use the climate control system to cool down the interior and, if necessary, also use defroster mode with the airflow directed toward the camera.
- Start driving the vehicle to lower the windshield temperature, which cools down the area around the camera.

If the **Some driver assist systems cannot operate: Clean front windshield or poor viewing condition.** message appears:

- Park your vehicle in a safe place, and make sure the windshield is clean. Clean the windshield if it is dirty.
- It may also appear in bad weather such as rain, fog, or snow, or when camera visibility is poor such as at night, in a tunnel, at dawn, or at dusk when the ambient conditions are dark.



If the message does not disappear after the vehicle has been driven for a while, have your vehicle checked by a dealer.

## Sonar Sensors\*

The sonar sensors (1) are situated in the front bumper, front grille, and rear bumper.

\*: Not available on all models

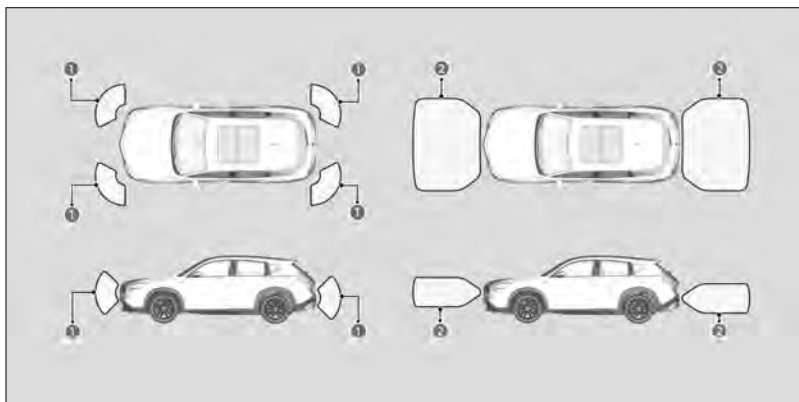
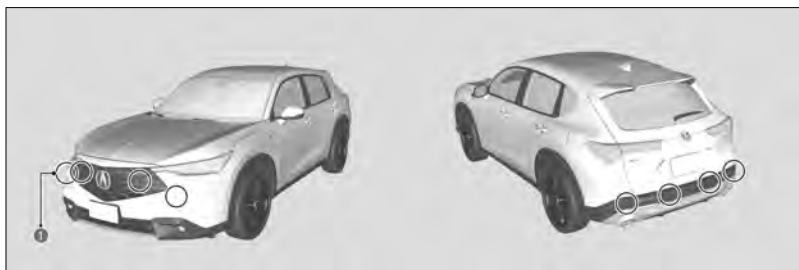

- ① Corner Sensor Range
- ② Center Sensor Range

## Handling of the Sonar Sensors

For the sonar sensors to work properly, do not:

- Hit the area around the sensors.
- Place stickers or other objects on or around the sensors.
- Attempt to take apart any sensor.
- Put any accessories on or around the sensors.

Consult with a dealer if:

- A sensor has been subjected to shock.
- Work needs to be done to the area around a sensor.
- The front bumper, front grille, or rear bumper has made contact with a hill, parking block, curb, embankment, etc.
- The vehicle has been driven through a deep puddle.
- The vehicle has been involved in a frontal or rear collision.

If the **Low speed braking control problem. Parking sensor obstructed.** message appears:

- Park your vehicle in a safe place, and make sure the sonar sensors or area around the sensors is clean.



If the message does not disappear after the vehicle has been driven for a while, have your vehicle checked by a dealer.

# Collision Mitigation Braking System™ (CMBS™)

## About CMBS™

The system can assist you when it determines there is a possibility of your vehicle colliding with a vehicle (including motorcycles) ahead from behind, an oncoming vehicle in front, a vehicle approaching from the side, a pedestrian, or someone riding a bicycle (moving bicycle). The CMBS™ is designed to alert you when the potential for a collision is determined, as well as assist in reducing speed, avoiding collisions, and reducing collision severity.

### Important Safety Reminder



The CMBS™ is designed to reduce the severity of an unavoidable collision. It does not prevent collisions nor stop the vehicle automatically. It is still your responsibility to operate the brake pedal and steering wheel appropriately according to the driving conditions.



Have your vehicle checked by a dealer if you find any unusual behavior of the system (e.g., the warning message appears too frequently).

## System Operation

The system starts monitoring the roadway ahead when your vehicle speed is about 3 mph (5 km/h) or above and will search for a vehicle (including motorcycles), pedestrian, or moving bicycle in front of you. CMBS™ operates when the system determines there is a possibility of a collision.

 Front Wide View Camera  P.280

The system has three alert stages for a possible collision.

### <Stage one> Situations where there is a risk of a collision with the vehicle ahead of you

The visual alert flashes. If the distance between your vehicle and the vehicle in front of you continues to decrease, the audible alert sounds in addition to the visual alert flashing.

### <Stage two> Situations where risk of a collision has increased and time to respond is reduced

Visual and audible alerts come on and the brakes are lightly applied.

### <Stage three> Situations where it is difficult to avoid a collision

Visual and audible alerts come on and the brakes are forcefully applied.

The system provides visual and audible alerts (1) of a possible collision, and stops if the collision is avoided.

» Take appropriate action to prevent a collision (apply the brakes, change lanes, etc.).



- Depending on circumstances, the CMBS™ may not go through all of the stages before initiating the last stage.
- After CMBS™ is activated and your vehicle stops or decelerates, CMBS™ will be deactivated based on the system's judgment.
- The CMBS™ may be canceled when you operate the steering wheel, brake, or accelerator pedal to avoid a collision.



You can change the distance (**Long/Normal/Short**) between vehicles at which the system's earliest collision alert will come on. When in **Long**, visual and audible alerts come on at a longer distance from a vehicle ahead than in **Normal** setting, and in **Short**, at a shorter distance than in **Normal**.

▼ **Models with 9" Color Touchscreen**

🔍 Vehicle Settings ▶ P.352

▼ **Models with 9" Color Touchscreen with Google built-in**

🔍 Customized Features ▶ P.249

## Operating Conditions

The conditions and targets of operation for CMBS™ are as follows:

### ■ When going straight

When your vehicle speed is about 3 mph (5 km/h) or more, and the speed difference with the target is about 3 mph (5 km/h) or more:

- The vehicle (including motorcycles) ahead of you

When your vehicle speed is about 3-62 mph (5-100 km/h), and the speed difference with the target is about 3 mph (5 km/h) or more:

- Stopped vehicle (including motorcycle)

\*: Not available on all models

- Oncoming vehicle
- Approaching vehicle from the side
- Pedestrian
- Moving bicycle

## ■ When turning left or right (only when there is a risk of a head-on collision)

When your vehicle speed is about 3-18 mph (5-30 km/h), and the speed difference with the target is about 3 mph (5 km/h) or more:

- Oncoming vehicle (including motorcycles)\*1
- Pedestrian
- Moving bicycle

\*1: Activates only when turning into the oncoming lane.

- The CMBS™ is not activated for about 15 seconds after the engine is turned on.
- When the CMBS™ is activated, it will continue to operate even if the accelerator pedal is partially depressed. However, it will be canceled if the accelerator pedal is fully depressed.
- The camera in the CMBS™ is also designed to detect pedestrians. However, this pedestrian detection feature may not activate or may not detect a pedestrian in front of your vehicle under certain conditions. Refer to the ones indicating the pedestrian detection limitations from the list.

 CMBS™ Limitations ▶ P.287

## Automatic shutoff

The CMBS™ may automatically shut itself off and the safety support indicator (amber) comes on and stays on when:

- You drive off-road or on a mountain road, or curved and winding road for an extended period.
- Driving in bad weather (rain, fog, snow, etc.).
- Driving with the parking brake applied.
- The front of the camera is obstructed by dirt, fog, rain, mud, wet snow, accessories, decals, stickers, film, etc.
- An abnormal tire condition is detected (incorrect tire size, flat tire, etc.).

Once the conditions that caused the CMBS™ to shut off improve or are addressed (e.g., cleaning), the system comes back on.

## CMBS™ On and Off

You can turn the system on and off using the driver information interface.

 Switching the Display ▶ P.346

 Safety Support ▶ P.350

- The CMBS™ is turned on every time you start the engine, even if you turned it off the last time you drove the vehicle.

- You cannot turn the CMBS™ off while driving.

## CMBS™ Limitations

In the following situations, the camera may be unable to correctly identify detectable targets or road conditions, potentially causing the CMBS™ to operate improperly.

### Environmental conditions

- Driving in bad weather (rain, fog, snow, etc.).
- Sudden changes between light and dark, such as an entrance or exit of a tunnel.
- There is little contrast between detectable targets and the background.
- Driving into low sunlight (e.g., at dawn or dusk).
- Strong light is reflected onto a detectable target or roadway.
- Water is being splashed or snow is being flung by the preceding vehicle (including motorcycles).
- Driving at night or in a dark place such as a tunnel (due to low-light conditions, vehicles, pedestrians, or moving bicycles may not be illuminated).

### Roadway conditions

- On snowy or wet roads with blurred lanes, tire tracks, light reflections, water spray, high contrast, etc.
- Driving on curvy, winding, undulating, or sloping roads.
- The road is hilly or the vehicle is approaching the crest of a hill.
- Your vehicle is strongly shaken on uneven road surfaces.

### Vehicle conditions

- Driving at night or in a dark place (e.g., a tunnel) with the headlights off.
- The front of the camera is obstructed by dirt, fog, rain, mud, wet snow, accessories, decals, stickers, film, etc.
- The inside of the windshield is fogged.
- There is residue on the windshield from the windshield wipers.
- When lighting is weak due to dirt covering the headlight lenses, or there is poor visibility in a dark place due to the headlights being improperly adjusted.
- An abnormal tire or wheel condition (incorrect sizes, varied sizes or construction, improperly inflated, compact spare tire\*, etc.).
- The vehicle is tilted due to heavy load in the cargo area or rear seats.
- The suspension has been modified.
- Driving with the parking brake applied.
- Camera vision is blocked by drops of water from the window washer, or by the wiper blades.
- Operation of the vehicle is unstable due to a slippery road, etc.

\*: Not available on all models



## Examples of limitations on the correct detection of the camera due to the condition of detectable targets

- The distance between your vehicle and the detectable target is too short.
- The detectable target suddenly cuts in front of or jumps out in front of you.
- The bicycle is stopped.
- The oncoming vehicle or vehicle ahead of you is sideways or facing diagonally.
- When the detectable target blends in with the background, preventing the system from recognizing it.
- When several pedestrians are moving ahead of you in a group.
- When several bicycles are moving ahead of you in a group.
- When a pedestrian or moving bicycle crosses the road too quickly.
- A pedestrian or moving bicycle approaches from the opposite direction.
- The headlights of the vehicle ahead of you or oncoming vehicle are lit on one side or not lit on either side in a dark place.
- When part of a pedestrian (heads, limbs, etc.) is hidden by a carried object.
- When a pedestrian is bent over or squatting, when their hands are raised, or when they are running.
- When the pedestrian is shorter than about 3.3 feet (1 meter) or taller than about 6.6 feet (2 meters) in height.
- When the pedestrian is pushing a stroller or bicycle.
- A vehicle (including motorcycles) is approaching diagonally from the side.
- A specially-shaped vehicle (such as a tank truck or a truck without a load) is approaching from the side.
- A vehicle (including motorcycles) approaching from the side is driving on a curve or hill.

## Examples of other limitations on detection or system operation

- When the vehicle ahead of you is a small motorcycle, motorcycle with a sidecar, wheelchair, or other specially shaped vehicle.
- When a vehicle is lower in the rear than the front such as trucks that are not carrying a load, or a narrow vehicle.
- When the detectable target is not in front of the vehicle.
- The speed difference between your vehicle and the detectable target is significantly large.
- The speed difference between your vehicle and the detectable target is too small and the distance between your vehicle and them is too short.
- The speed difference between your vehicle and a detectable target approaching from the side is significantly large.
- The speed difference between your vehicle and a detectable target approaching from the side is too small and the distance between your vehicle and them is too short.
- When a vehicle (including motorcycles) or moving bicycle in front of you slows suddenly.
- When the driver operates the brake pedal and steering wheel to avoid a collision.
- When you approach the detectable target while accelerating rapidly or operating the steering wheel (except when turning left at an intersection, etc.)<sup>1</sup>
- When the moving bicycle is a child-sized bicycle, folding bicycle, three-wheeler or other bicycle with small tires, or a long bicycle like a tandem bicycle.

- When the front of the camera cannot correctly identify the shape of the detectable target.
- When the minimum ground clearance of a vehicle that is ahead of you or approaching from the side is extremely high.
- When turning left or right and your turn signal is not activated in the same direction you are turning.

\*1: When there is a possibility of a frontal collision with the oncoming vehicle while turning left, the CMBS™ is activated. However, it may not be activated if you suddenly turn the steering wheel.

## With Little Chance of a Collision

Even if there is little chance of a collision, the CMBS™ may activate in the following situations, such as when the system determines that there is a possibility of collision with a detectable target.

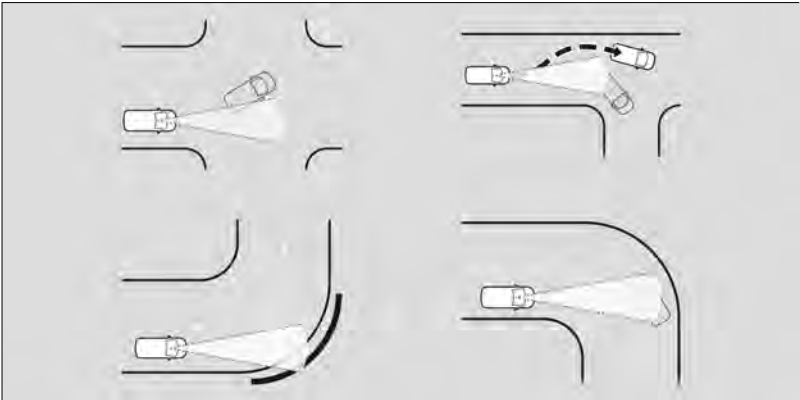

- When your vehicle approaches a vehicle ahead (including a motorcycle) that is turning left or right.
- Your vehicle approaches another vehicle (including motorcycles) ahead of you and you change lanes to pass.
- When there are detectable targets or any structures around the curved road.
- When driving through curves, your vehicle comes to a point where the oncoming vehicle is right in front of you.
- When your vehicle approaches a detectable target.
- When detectable targets are passing in front of you.
- When you drive under a low structure or through a narrow gate at high speed.
- When approaching a stationary vehicle (including motorcycles) or walls, such as when parking.
- A vehicle (including motorcycles) approaches from the side as it is driving through a curve.
- You pass by a detectable target that approaching from the side in front of you.
- You attempt to pass in front of a vehicle (including motorcycles) or bicycle while you are turning left or right.

- A vehicle (including motorcycles) or bicycle is attempting to pass in front of your vehicle while you are turning left or right.
- A detectable target enters the path of your vehicle and stops in front of you, or changes direction.
- When you are turning left or right, a crossing pedestrian enters the path of your vehicle and stops in front of you, or changes direction.
- When your vehicle passes near a detectable target.
- Roadway objects or structures such as guard rails, poles, trees, parked vehicles, buildings, walls, etc., or road markings and road lines are misinterpreted as detectable targets.

# Low Speed Braking Control\*

## About Low Speed Braking Control

Using sonar sensors, this system can detect if there is danger of a potential collision with a wall or other obstacle during normal driving or when the accelerator pedal is depressed with too much force. The system then assists in avoiding collisions and reducing damage from impact through assistive braking and/or assistive driving power suppression.

### Q Sonar Sensors ▶ P.281

- If Low Speed Braking Control activates in a situation where you do not want automatic brake application (such as when the vehicle is between two railroad crossing gates), simply press the brake pedal to deactivate the system and then continue to drive as intended.
- The vehicle will release the brake and start moving a few seconds after the system is activated. To keep the vehicle stopped, keep the brake pedal depressed or put the transmission into **P**.
- In order to prevent the system from activating when not needed, always turn it off during vehicle maintenance; when loading on ships, trucks, and so on; when using a chassis dynamometer or free rollers for inspection; or when washing the car in conveyor type car wash machine.
- After Low Speed Braking Control has activated once, it will not activate again for the same obstacle. It can be activated again after driving for a certain distance after last activation.
- Low Speed Braking Control activates separately when moving forward and reversing. (For example, if it activates when moving forward, it can be activated again immediately if reversing.) However, if assistive braking has been activated, in order to activate assistive driving power suppression again, it is necessary to drive for a certain distance to reset the system.

### WARNING

The Low Speed Braking Control System cannot avoid all collisions and may not reduce damage in each situation where the accelerator is mistakenly or aggressively pressed. Overreliance on the system may result in a collision with serious injury or death. Always check your surroundings, your shift position, and your pedal use. Driver remains responsible for safely operating the vehicle.

\*: Not available on all models

## System Operation

### Assistive Braking

Assistive braking provides a visual and audible alert when the vehicle is moving between approximately 1 and 6 mph (2 and 10 km/h) and there is the possibility of a collision with a detected wall or other obstacles, as well as providing assistance with braking.

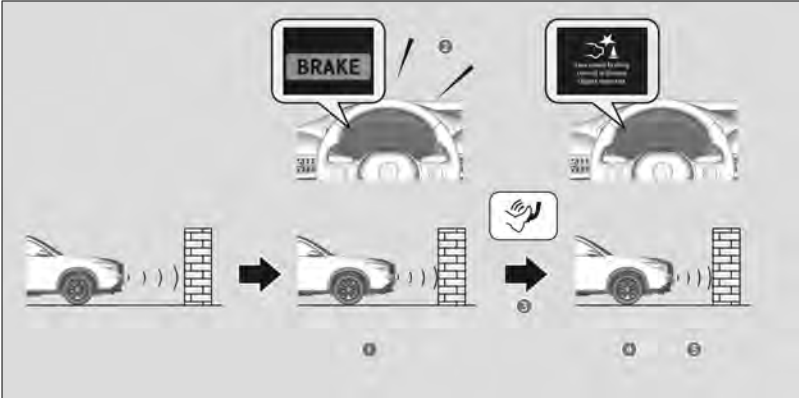

- ① The vehicle applies brake
- ② Audible Alert
- ③ Driver depresses brake pedal
- ④ Stop
- ⑤ Release brake after maintaining stationary position



If only the rear parking sensors are turned off, the assistive braking will not work when reversing.

Customized Features ▶ P.249

### Assistive Driving Power Suppression

When the vehicle is stopped or moving at less than 6 mph (10 km/h) and there is an obstacle such as a wall detected near the front or back of the vehicle, if the accelerator pedal is depressed more than necessary, the system will inform you with a visual and audible alert. At the same time, the system will prevent sudden forward or backward movement by limiting the output of the engine, then assistive braking will activate when you get closer to the obstacle.

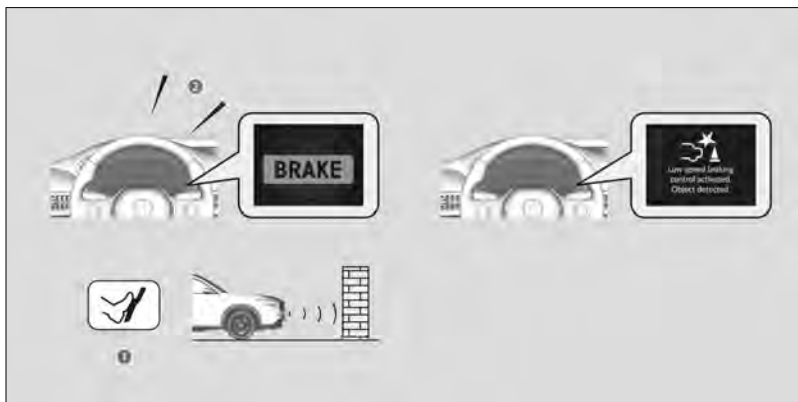

- 1 Accidental depression of the accelerator/Limiting the output of the engine
- 2 Audible Alert

Assistive driving power suppression will not activate in the following situations:

**When moving forward:**

When on a steep slope or the shift position is in **P**, **R**, or **N**.

**When reversing:**

When on a steep slope or the shift position is in a position other than **R**.



If only the rear parking sensors are turned off, the assistive driving power suppression will not work when reversing.

[Q Customized Features ▶P.249](#)

## Conditions for Cancellation

### Conditions for assistive driving power suppression:

- When the accelerator is no longer depressed.
- When the accelerator is depressed for approximately four seconds.
- When the brake pedal is depressed.

### Conditions for assistive braking cancellation:

- A certain amount of time has passed since activation.

## Low Speed Braking Control System On and Off

You can turn the system on and off using the driver information interface.

[Q Switching the Display ▶P.346](#)

[Q Safety Support ▶P.350](#)

- The Low Speed Braking Control system is turned on every time you turn the engine on, even if you turned it off the last time you drove the vehicle.
- The Low Speed Braking Control system may temporarily turn off after reconnecting the 12-volt battery. The system will automatically turn ON after the vehicle has been moving at over 10 mph (15 km/h) for some time.

## Low Speed Braking Control System Limitations

The system may not operate correctly under the following conditions:

### Examples of obstacles the sonar sensor cannot detect

- Obstacles that do not reflect sound waves well, such as people, snow, cloth, sponges, etc.
- Thin obstacles such as fences, bicycles, sign posts, etc.
- Short or small obstacles.
- Obstacles immediately in front of the bumper.
- Moving objects or obstacles that suddenly enter the road.
- Obstacles that are not perpendicular to the ground.

### Examples of situations where the sonar sensors cannot detect obstacles

- The sonar sensors are dirty (covered by snow, water, mud, etc.).
- The vehicle is too hot or cold.
- The steering wheel is turned sharply when approaching the obstacle at an angle.

### Examples of other cases where the system may not work correctly

- The vehicle is tilted due to heavy load in the cargo area or rear seats.
- Bad weather conditions such as heavy rain, fog, snow, sandstorms, etc.
- The ambient temperature/humidity is too high or low.
- When going down a very steep slope.
- When driving off-road such as on dirt, grass, or rock.
- When close to other vehicles with sonar sensors or other objects that emit ultrasonic waves.
- An abnormal tire or wheel condition (incorrect sizes, varied sizes or construction, improperly inflated, compact spare tire\*, etc.).
- The suspension has been modified.

### Situations where the system may activate even without risk of a collision

- When passing through short or narrow gates.
- When driving on uneven surfaces, grassy areas, or places with steps.
- When a sloped pillar or wall is protruding from a high position.

\*: Not available on all models

- When there are obstacles next to the road.
- When driving toward flags, curtains, tree branches, railroad crossing bars, etc.
- When driving on flooded roads.



# Road Departure Mitigation System

## About Road Departure Mitigation System

Alerts and helps assist you when the system detects a possibility of your vehicle crossing over detected lane markings, or approaching the outer edge of the pavement (into grass or gravel shoulder) or a detected oncoming vehicle.

🔍 Front Wide View Camera ▶P.280

### Important Safety Reminder

Like all assistance systems, the Road Departure Mitigation system has limitations. Overreliance on the Road Departure Mitigation system may result in a collision. It is always your responsibility to keep the vehicle within your driving lane.

## System Operation

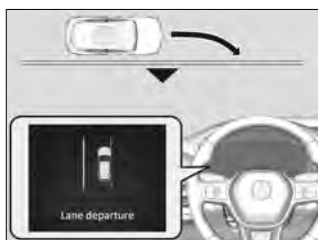

The camera monitors left and right lane markings in white (or yellow), the outer edge of the pavement (bordered by grass or gravel road shoulder), or a detected oncoming vehicle. If your vehicle approaches any detected lane markings, the outer edge of the pavement (bordered by grass or gravel), or a detected oncoming vehicle when the turn signals have not been engaged, the system activates.

» If the system cannot detect lane markings (in white or yellow), no assistance will be provided to avoid approaching oncoming vehicles.

In addition to a visual alert, the system assists with steering and alerts you with rapid steering wheel vibrations to help you remain within the detected lane.

The system cancels assisting operations when you turn the steering wheel to avoid crossing over detected lane markings or approaching the outer edge of the pavement (into grass or gravel road shoulder) or an oncoming vehicle.

If the system operates several times without detecting driver response, the system beeps to alert you.

- The Road Departure Mitigation system may automatically shut off and the safety support indicator (amber) comes and stays on.
- There are times when you may not notice the Road Departure Mitigation system functions due to your operation of the vehicle or road surface conditions.
- The Road Departure Mitigation system function can be impacted when the vehicle is driven on the inside edge of a curve, or outside of a lane, or driven in a narrow lane.



If Lane Keeping Assist System (LKAS) is off, the message may appear if the system has determined that there is a possibility of your vehicle crossing over detected lane markings, the outer edge of the pavement (into a grass or gravel road shoulder) or oncoming vehicle.

## Operating Conditions

The system activates when all of the following conditions are met:

- The vehicle is on a straight or slightly curved road.
- The turn signals are off.
- The system determines that the driver is not actively accelerating, braking, or steering.
- The vehicle is traveling between about 40 and 93 mph (64 and 150 km/h).

The Road Departure Mitigation system is not activated for about 15 seconds after the engine is turned on.



You can set the timing for Road Departure Mitigation System activation.

### ▼ Models with 9" Color Touchscreen

🔍 Vehicle Settings ▶ P.352

### ▼ Models with 9" Color Touchscreen with Google built-in

🔍 Customized Features ▶ P.249

## Road Departure Mitigation System On and Off

You can turn the system on and off using the driver information interface.

🔍 Switching the Display ▶ P.346

🔍 Safety Support ▶ P.350

The Road Departure Mitigation system is in the previously selected on or off setting each time you start the engine.

## Road Departure Mitigation System Limitations

The system may not properly detect lane markings (in white or yellow), the outer edge of the pavement (into grass or gravel road shoulder), or an oncoming vehicle under certain conditions. Some examples of these conditions are listed below.

\*: Not available on all models

## ■ Environmental conditions

- There is little contrast between lane lines and the roadway surface.
- Driving in bad weather (rain, fog, snow, etc.).
- Driving on a snowy or wet roadway.
- Driving into low sunlight (e.g., at dawn or dusk).
- Shadows of adjacent objects (trees, buildings, guard rails, vehicles, etc.) are parallel to white (or yellow) lines.
- Sudden changes between light and dark, such as the entrance or exit of a tunnel or the shadows of trees, buildings, etc.
- Strong light is reflected onto the roadway.
- Driving at night or in a dark place such as a tunnel (due to low-light conditions, lane lines, the road surface, or oncoming vehicles may not be illuminated).
- The distance between your vehicle and the vehicle ahead of you is too short, and lane lines and the road surface are not visible.
- The outer edge of the road is bordered by objects, materials, etc. other than grass or gravel.

## ■ Roadway conditions

- Driving on a road with temporary lane markings.
- Faint, multiple, or varied lane markings are visible on the roadway due to road repairs or deteriorated lane markings.
- The roadway has merging, split, or crossing lines, such as at an intersection or crosswalk.
- The lane markings are extremely narrow, wide, or changing.
- Part of the lane markings are hidden by an object, such as a vehicle.
- The road is hilly or the vehicle is approaching the crest of a hill.
- Your vehicle is strongly shaken on uneven road surfaces.
- When objects on the road (curb, guard rail, pylons, etc.) are recognized as white (or yellow) lines.
- Driving on rough or unpaved roads, or over bumpy surfaces.
- Driving on roads with double lane lines.
- Driving on snowy or slippery roads.
- Passing through an exit or an interchange.
- The pavement is only partially visible due to snow or puddles on the road.
- Driving on unpaved or rutted roads.
- White (or yellow) lines are not recognized correctly due to road conditions such as curves, twists, or hills.

## ■ Vehicle conditions

- When lighting is weak due to dirt covering the headlight lenses, or there is poor visibility in a dark place due to the headlights being improperly adjusted.
- The front of the camera is obstructed by dirt, fog, rain, mud, wet snow, accessories, decals, stickers, film, etc.
- Driving at night or in a dark place (e.g., a tunnel) with the headlights off.
- When the driver operates the brake pedal and steering wheel.

- There is residue on the windshield from the windshield wipers.
- The inside of the windshield is fogged.
- An abnormal tire or wheel condition (incorrect sizes, varied sizes or construction, improperly inflated, compact spare tire\*, etc.).
- The vehicle is tilted due to heavy load in the cargo area or rear seats.
- The suspension has been modified.

### ■ Examples of limitations on detection due to the condition of oncoming vehicles

- The oncoming vehicle or vehicle ahead of you is sideways.
- The oncoming vehicle jumps out in front of you.
- When the oncoming vehicle blends in with the background, preventing the system from recognizing it.
- The headlights of an oncoming vehicle are lit on one side or not lit on either side in a dark place.
- The distance between your vehicle and the oncoming vehicle is too short.
- Part of the oncoming vehicle is not visible due to the vehicle ahead of you.
- There are multiple oncoming lanes or turning lanes.
- The vehicle in the adjacent lane is parked or moving at an extremely slow speed.
- When the oncoming vehicle is specially-shaped.
- When the camera cannot correctly identify the shape of the oncoming vehicle.

### ■ With Little Chance of a Collision

The Road Departure Mitigation system may activate in the below conditions.

- When driving through curves, your vehicle comes to a point where an oncoming vehicle is right in front of you.

\*: Not available on all models

# Adaptive Cruise Control (ACC) with Low Speed Follow

## About ACC with Low Speed Follow

Helps maintain a constant vehicle speed and a set following-interval behind a vehicle detected ahead of yours and, if the detected vehicle comes to a stop, can decelerate and stop your vehicle, without you having to keep your foot on the brake or the accelerator.

 Front Wide View Camera ▶ P.280

### Important Reminder

As with any system, there are limits to ACC with Low Speed Follow. Use the brake pedal whenever necessary, and always keep a safe interval between your vehicle and other vehicles.

## WARNING

Improper use of ACC with Low Speed Follow can lead to a crash. Use ACC with Low Speed Follow only when driving on motorways and in good road and weather conditions.

ACC with Low Speed Follow has limited braking capability and may not stop your vehicle in time to avoid a collision with a vehicle that quickly stops in front of you. Always be prepared to apply the brake pedal if the conditions require.

Exiting a vehicle that has been stopped while the ACC with Low Speed Follow system is operating can result in the vehicle moving without operator control. A vehicle that moves without operator control can cause a crash, resulting in serious injury or death.

Never exit a vehicle when the vehicle is stopped by ACC with Low Speed Follow.





Do not use ACC with Low Speed Follow under the following conditions:

- On roads with frequent lane change or continuous stop and go traffic
- On roads with sharp turns
- On roads with undulating slopes
- On roads with steep uphill or steep downhill slopes
- On roads with toll collection facilities or other objects between lanes of traffic, or in parking areas, or facilities with drive through access
- On roads with slippery or icy surfaces

## How to Activate ACC with Low Speed Follow



- [1] Press the  button (1) while the shift position is in **D** or **S**.  
 » The  indicator (white) (2) comes on.

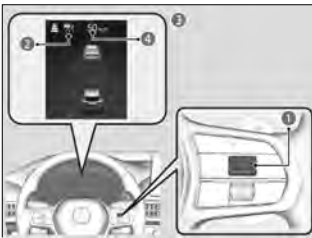

- [2] Press the **RES/+**/**SET/-** switch (1) up or down.  
 » The system will start operating at the set speed.  
 » The icons and set speed will be displayed on the gauge.

- 2**  Indicator (Green, White/Green)  
**3** On when ACC with Low Speed Follow begins  
**4** Set Vehicle Speed (White)

- ACC with Low Speed Follow does not operate while the brake pedal is depressed.
- When driving at 20 mph (30 km/h) or less, the vehicle speed is set to 20 mph (30 km/h). If your vehicle is stationary, you can set the vehicle speed even with the brake pedal depressed.
- When you use ACC with Low Speed Follow, Straight Driving Assist (a feature of the Electric Power Steering system) is activated.  
 By enabling the steering system to automatically compensate for natural steering pull, Straight Driving Assist makes it easier for you to keep your vehicle in a straight line.
- When not using ACC with Low Speed Follow, press the  button to turn off the system.

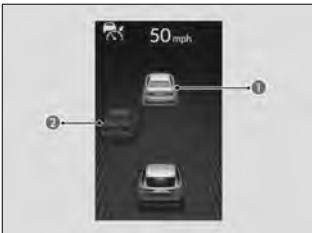

If a vehicle ahead enters the detectable range, icon (1) appears, and the system adjusts your vehicle's speed within the set range in order to keep the vehicle's set following-interval.

- 1** Control target vehicle  
**2** Outside of control target vehicle



If there is no vehicle ahead, your vehicle maintains the set speed. If a vehicle ahead leaves due to actions such as changing lanes, the system will slowly accelerate to the set speed and then maintain it.



Your vehicle also stops automatically. The message (1) appears on the gauge. When the vehicle ahead of you starts again, if you press the **RES/+ / SET/-** switch up or down, or depress the accelerator pedal, ACC with Low Speed Follow operates again within the previously set speed.

» When your vehicle stops automatically because a vehicle detected ahead of you has stopped, the interval between the two vehicles will vary based on the interval setting.

2  Indicator (Green)



If no vehicle is ahead of you before you resume driving, depress the accelerator pedal and ACC with Low Speed Follow will operate again within the prior set speed.

1  Indicator (White/Green)

- When a vehicle whose speed is slower than your set speed comes in or cuts in front of you and is detected by the camera, your vehicle starts to slow down.
- Even if the interval between your vehicle and the vehicle detected ahead is short, ACC with Low Speed Follow may start accelerating your vehicle under the following circumstances:
  - » The vehicle ahead of you is going at almost the same speed as, or faster than, your vehicle.
  - » A vehicle that cuts in front of you is going faster than your vehicle, gradually increasing the interval between the vehicles.
- While driving down steep hills, ACC with Low Speed Follow brakes to inhibit excessive acceleration for maintaining the set speed. However, the vehicle speed may become faster than the set speed.
- When the vehicle ahead of you moves away, such as when entering an interchange or rest area, ACC with Low Speed Follow may continue to maintain the set following-interval for a short time.
- When ACC with Low Speed Follow slows your vehicle by applying the brakes, your vehicle's brake lights will illuminate.

- ACC with Low Speed Follow may temporarily control the interval between your vehicle and the vehicle in adjacent lane or surroundings of your vehicle depending on the road conditions (e.g., curves) or vehicle conditions (e.g., operating the steering wheel or the vehicle location in the lane).

If the vehicle ahead of you slows down abruptly, or if another vehicle cuts in front of you, the beeper (1) sounds and a message appears.

» Depress the brake pedal, and keep an appropriate interval from the vehicle ahead.



- You can temporarily increase the vehicle speed. In this case, there is no audible or visual alert even if a vehicle is in the ACC with Low Speed Follow range. ACC with Low Speed Follow stays on unless you cancel it. Once you release the accelerator pedal, the system resumes an appropriate speed for keeping the following-interval while a vehicle ahead is within the ACC with Low Speed Follow range.



You can also set the system to beep when a vehicle detected in front of you comes in and goes out of the ACC with Low Speed Follow detecting range.

▼ **Models with 9" Color Touchscreen**

🔍 Vehicle Settings\* ▶ P.352

▼ **Models with 9" Color Touchscreen with Google built-in**

🔍 Customized Features ▶ P.249



You can switch the displayed set speed measurements between mph and km/h.

🔍 Speed/distance units ▶ P.354

▼ **Models with 9" Color Touchscreen**

🔍 Vehicle Settings\* ▶ P.352

▼ **Models with 9" Color Touchscreen with Google built-in**

🔍 Customized Features ▶ P.249

\*: Not available on all models



## To Adjust the Vehicle Speed

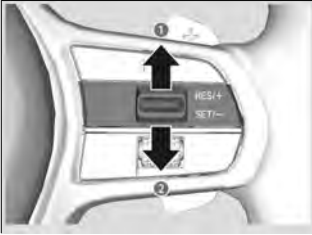

### 1 Pressing the RES/+ / SET/- switch up

- › Each press increases speed by about 1 mph or 1 km/h.
- › Press and hold to increase speed by about 5 mph or 5 km/h.

### 2 Pressing the RES/+ / SET/- switch down

- › Each press decreases speed by about 1 mph or 1 km/h.
- › Press and hold to decrease speed by about 5 mph or 5 km/h.

- If a vehicle detected ahead is going at a speed slower than your increased set speed, ACC with Low Speed Follow may not accelerate your vehicle. This is to maintain the set interval between your vehicle and the vehicle ahead.
- When you depress the accelerator pedal and then press down and release the RES/+ / SET/- switch, the current speed of the vehicle is set.

## To Set or Change Following-interval



Press the Interval button (1) to change the ACC with Low Speed Follow following-interval.

- › Each time you press the button, the following-interval (the interval behind a vehicle detected ahead of you) setting cycles through nearest, mid, far, and furthest following-intervals.
- › Determine the most appropriate following-interval setting based on your specific driving conditions. Be sure to adhere to any following-interval requirements set by local regulation.
- › The higher your vehicle's following-speed is, the higher the nearest, mid, far, or furthest following-interval becomes.



The distance between vehicles is:

- About 87 feet (27 m) (vehicle speed is 50 mph [80 km/h])
- About 108 feet (33 m) (vehicle speed is 62 mph [100 km/h])

### 1 Adaptive Cruise Control (ACC) with Low Speed Follow Interval Indicator



The distance between vehicles is:

- About 115 feet (35 m) (vehicle speed is 50 mph [80 km/h])
- About 142 feet (43 m) (vehicle speed is 62 mph [100 km/h])



The distance between vehicles is:

- About 144 feet (44 m) (vehicle speed is 50 mph [80 km/h])
- About 181 feet (55 m) (vehicle speed is 62 mph [100 km/h])



The distance between vehicles is:

- About 177 feet (54 m) (vehicle speed is 50 mph [80 km/h])
- About 220 feet (67 m) (vehicle speed is 62 mph [100 km/h])

## To Cancel

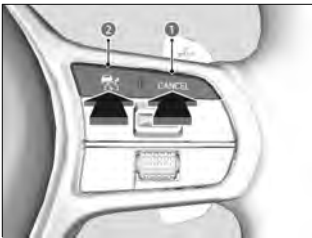

Any of the following operations will cause the ACC with Low Speed Follow to be canceled.

- Press the **CANCEL** button (1).
  - » The indicator (green, white/green) on the gauge changes to the indicator (white).
- Depress the brake pedal while the vehicle is moving forward.
  - » The indicator (green, white/green) on the gauge changes to the indicator (white).
- Press the button (2).
  - » indicator (green, white/green) goes off.

## Resuming the prior set speed





When you turn off ACC with Low Speed Follow by pressing the **CANCEL** button or depressing the brake pedal, the prior set speed (1) is displayed on the gauge in gray.

You can activate ACC with Low Speed Follow with the prior set speed displayed on the gauge (in gray) by pressing the **RES/+SET/-** switch up.

### 2 Indicator (White)

## To Switch the Cruise Mode



Press and hold the  button (3) for one second.  
 » The  indicator (white) (4) on the gauge changes to the  indicator (white) (5) and switches to the cruise mode.

To switch back to ACC with Low Speed Follow, press and hold the interval button again for one second.

- 1 Display for ACC with Low Speed Follow
- 2 Display for Cruise Mode

You cannot switch ACC with Low Speed Follow to Cruise Control when setting a vehicle speed or activating ACC with Low Speed Follow.

 Always be aware which mode you are in.  
 When you are driving in Cruise mode, the system will not assist you to maintain a following-interval from a vehicle ahead of you.

## How to Activate Cruise Mode



When driving at 20 mph (30 km/h) or above, press the **RES/+ / SET/-** switch up or down.

» The system will start operating at the set speed.  
 » The icons and set speed will be displayed on the gauge.







- 1  Indicator (Green)
- 2 Set Vehicle Speed (White)

## To Adjust the Vehicle Speed

The adjusting procedure for the vehicle speed is the same as for ACC with Low Speed Follow.

## To Cancel

Cruise control is canceled when you do any of the following or when your vehicle speed drops below 17 mph (25 km/h):

- Press the **CANCEL** button.
  - » The  indicator (green) on the gauge changes to the  indicator (white).
- Depress the brake pedal.
  - » The  indicator (green) on the gauge changes to the  indicator (white).
- Press the  button.
  - » The  indicator (green) goes off.

## Resuming the prior set speed



### 2 Indicator (White)

When you turn off cruise control by pressing the **CANCEL** button or depressing the brake pedal, the prior set speed (1) is displayed on the gauge in gray.

You can activate cruise control with the prior set speed displayed on the gauge (in gray) and by pressing the **RES/+ / SET/-** switch up while driving at 20 mph (30 km/h) or above.

## ACC with Low Speed Follow Limitations

The system may automatically shut off under certain conditions. Some examples of these conditions are listed below. Other conditions may reduce some of the ACC with Low Speed Follow functions.

### Environmental conditions

- Driving in bad weather (rain, fog, snow, etc.).
- Sudden changes between light and dark, such as the entrance or exit of a tunnel or the shadows of trees, buildings, etc.
- Strong light is reflected onto vehicles or road surfaces.
- Water is sprayed by or snow blown from a vehicle ahead.
- Driving at night or in a dark place such as a tunnel (due to low-light conditions, the whole vehicle may not be illuminated).
- Driving into low sunlight (e.g., at dawn or dusk).

### Roadway conditions

- Driving on curvy, winding, undulating, or sloping roads.
- Driving on rutted roads (snowy or unpaved roads, etc.).

- Puddles or a film of water is on the road surface.
- Your vehicle is strongly shaken on uneven road surfaces.

### Vehicle conditions

- The vehicle is tilted due to heavy load in the cargo area or rear seats.
- The front of the camera is obstructed by dirt, fog, rain, mud, wet snow, accessories, decals, stickers, film, etc.
- Driving at night or in a dark place (e.g., a tunnel) with the headlights off.
- There is residue on the windshield from the windshield wipers.
- The inside of the windshield is fogged.
- When lighting is weak due to dirt covering the headlight lenses, or there is poor visibility in a dark place due to the headlights being improperly adjusted.
- An abnormal tire or wheel condition (incorrect sizes, varied sizes or construction, improperly inflated, compact spare tire\*, etc.).
- The suspension has been modified.

### Examples of conditions under which the camera may not correctly detect the vehicle ahead of you

- A vehicle suddenly crosses in front of you.
- The interval between your vehicle and the vehicle ahead of you is too short.
- When the vehicle ahead of you blends in with the background, preventing the system from recognizing it.
- When the height of a vehicle ahead of you is low.
- The headlights of the vehicle ahead of you are lit on one side or not lit on either side in a dark place.

### Examples of conditions under which the system may not work properly

- A vehicle ahead of you stops and the speed difference between your vehicle and the vehicle ahead of you is significantly large.
- When the vehicle ahead of you slows suddenly.
- When a vehicle ahead of you is specially-shaped.
- When a vehicle is lower in the rear than the front such as trucks that are not carrying a load, or a narrow vehicle.
- When your vehicle or the vehicle ahead of you is driving on the edge of the lane.
- When the vehicle ahead of you is a narrow vehicle such as a motorcycle.
- When the minimum ground clearance of a vehicle ahead of you is extremely high.
- When the camera cannot correctly identify the shape of the vehicle ahead of you.

### Automatic cancellation

The beeper sounds and a message appears on the driver information interface when ACC with Low Speed Follow is automatically canceled. Any of these conditions may cause the ACC with Low Speed Follow to automatically cancel:

\*: Not available on all models

- Bad weather (rain, fog, snow, etc.)
- The vehicle ahead of you cannot be detected.
- An abnormal tire condition is detected, or the tires are skidding.
- Driving on a mountainous road for extended periods, or driving off road.
- Abrupt steering wheel movement.
- When the ABS, VSA®, CMBS™, or Low Speed Braking Control\* is activated.
- When the VSA® system indicator comes on.
- When the vehicle is stopped on a very steep slope.
- When you manually apply the parking brake.
- Water is sprayed by or snow blown from a vehicle ahead.
- Driving into low sunlight (e.g., at dawn or dusk).
- When the detected vehicle within the ACC with Low Speed Follow range is too close to your vehicle.
- When accelerating rapidly.
- The front of the camera is obstructed by dirt, fog, rain, mud, wet snow, accessories, decals, stickers, film, etc.
- The vehicle is loaded heavy load in the cargo area or rear seats.
- When passing through a dark place, such as a tunnel.
- When the parking brake and brake system indicator (amber) comes on.
- The vehicle has repeatedly applied the brakes to maintain the set speed (for example, you are descending a long slope).
- When the system doesn't detect any driving actions from the driver for a certain amount of time while the LKAS or Traffic Jam Assist is also activated.
- The engine is stopped.
- The driver's seat belt is unfastened when the vehicle is stationary.
- The vehicle stops for more than 10 minutes.

\*: Not available on all models

# Lane Keeping Assist System (LKAS)

## About LKAS

Provides steering input to help keep the vehicle in the middle of a detected lane and provides tactile and visual alerts if the vehicle is detected drifting out of its lane.

🔍 Front Wide View Camera ▶ P.280

### Important Safety Reminders

The LKAS is for your convenience only. It is not an autonomous driving system and always requires driver attention and control. The system does not work if you take your hands off the steering wheel or fail to steer the vehicle.

The LKAS is convenient when it is used on expressways or freeways. It is always your responsibility to safely operate the vehicle and avoid collisions.

❗ If the vehicle drifts toward either left or right lane line due to the system applying torque, turn off the LKAS and have your vehicle checked by a dealer.

## Lane Keep Support Function

Provides assistance to keep the vehicle in the center of the lane. When the vehicle nears a white or yellow line, steering force of the electric power steering will become stronger.

## Lane Departure Warning Function

In some driving situations, when the system detects that the vehicle has departed from its lane, the LKAS alerts you with slight steering wheel vibration as well as a warning display.

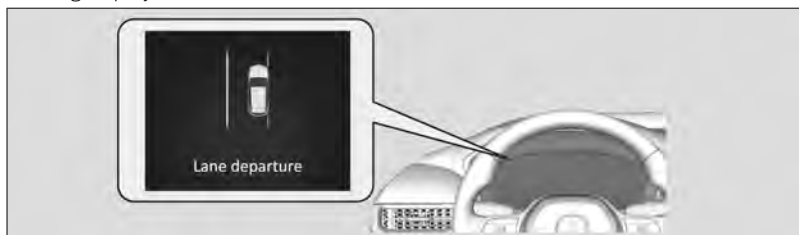

## Operating Conditions

- The lane in which you are driving has detectable lane markers on both sides, and your vehicle is in the center of the lane.
- You are driving on a straight or slightly curved road.
- The turn signals are off.
- The brake pedal is not suddenly depressed.
- The vehicle is traveling between about 45 and 90 mph (72 and 145 km/h).

## How to Activate LKAS



[1] Press the  button.

- » LKAS indicator (white) (1) appears on the gauge. The system is standby.
- » If traffic lane lines are detected, white lines (2) appear on the gauge.



[2] Keep your vehicle near the center of the lane while driving.

- » The system starts operating when the LKAS indicator (green) (1) and the green lines (2) appear.

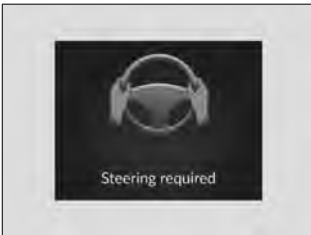

If the driver takes their hands off the steering wheel or does not adequately maintain control of steering, the warning display will appear. If the driver does not grip the steering wheel after the warning display has repeatedly appeared, a warning buzzer will sound and LKAS will be canceled.

## To Cancel

Press the  button.

- » To operate LKAS, press the  button again.
- » The LKAS is turned off every time you stop the engine, even if you turned it on the last time you drove the vehicle.



## The LKAS may be automatically suspended when:

When the LKAS is suspended under the following circumstances, the LKAS indicator changes green to white, and the beeper sounds (if activated).

- Your vehicle is driving to the right or the left of the lane.
- The system fails to detect lane lines.
- The steering wheel is turned quickly.
- You fail to steer the vehicle.
- Driving through a sharp curve.
- The ABS, VSA®, or CMBS™ is activated.
- The brake pedal is suddenly depressed.
- Driving at a speed in excess of approximately 94 mph (150 km/h).

Once these conditions no longer exist, the LKAS automatically resumes.



You can change the LKAS suspended beep on and off.

### ▼ Models with 9" Color Touchscreen

🔍 Vehicle Settings ▶ P.352

### ▼ Models with 9" Color Touchscreen with Google built-in

🔍 Customized Features ▶ P.249

## LKAS Limitations

The system may not detect lane markings (in white or yellow), and LKAS may not function properly under certain conditions, including the following:

### ■ Environmental conditions

- There is little contrast between lane lines and the roadway surface.
- Driving in bad weather (rain, fog, snow, etc.).
- Driving on a snowy or wet roadway.
- Driving into low sunlight (e.g., at dawn or dusk).
- Shadows of adjacent objects (trees, buildings, guard rails, vehicles, etc.) are parallel to white (or yellow) lines.
- Sudden changes between light and dark, such as the entrance or exit of a tunnel or the shadows of trees, buildings, etc.
- Driving at night or in a dark place such as a tunnel (due to low-light conditions, lane lines or the road surface may not be illuminated).
- The distance between your vehicle and the vehicle ahead of you is too short, and lane lines and the road surface are not visible.
- Strong light is reflected onto the roadway.

\*: Not available on all models

## Roadway conditions

- Driving on a road with temporary lane markings.
- Faint, multiple, or varied lane markings are visible on the roadway due to road repairs or deteriorated lane markings.
- The roadway has merging, split, or crossing lines, such as at an intersection or crosswalk.
- The lane markings are extremely narrow, wide, or changing.
- Part of the lane markings are hidden by an object, such as a vehicle.
- The road is hilly or the vehicle is approaching the crest of a hill.
- Your vehicle is strongly shaken on uneven road surfaces.
- When objects on the road (curb, guard rail, pylons, etc.) are recognized as white (or yellow) lines.
- Driving on rough or unpaved roads, or over bumpy surfaces.
- Driving on roads with double lane lines.
- Driving on snowy or slippery roads.
- The pavement is only partially visible due to snow or puddles on the road.
- There is a film of water or puddles on the road surface.
- White (or yellow) lines are not recognized correctly due to road conditions such as curves, twists, or hills.
- Driving on unpaved or rutted roads.
- Passing through an exit or an interchange.

## Vehicle conditions

- When lighting is weak due to dirt covering the headlight lenses, or there is poor visibility in a dark place due to the headlights being improperly adjusted.
- The front of the camera is obstructed by dirt, fog, rain, mud, wet snow, accessories, decals, stickers, film, etc.
- Driving at night or in a dark place (e.g., a tunnel) with the headlights off.
- There is residue on the windshield from the windshield wipers.
- The inside of the windshield is fogged.
- An abnormal tire or wheel condition (incorrect sizes, varied sizes or construction, improperly inflated, compact spare tire\*, etc.).
- The vehicle is tilted due to a heavy load in the cargo area or rear seats.
- The suspension has been modified.

\*: Not available on all models

# Traffic Jam Assist

## About Traffic Jam Assist

The Traffic Jam Assist system uses a camera mounted to the upper portion of the windshield to detect and monitor left and right white (or yellow) traffic lane lines. Based on inputs from the camera, the system can apply steering torque to keep your vehicle in the center of the detected lane.

 Front Wide View Camera ▶ P.280

### Important Safety Reminders

Traffic Jam Assist is for your convenience only. It is not an autonomous driving system and always requires driver attention and control. The system does not work if you take your hands off the steering wheel or fail to steer the vehicle.

Traffic Jam Assist is convenient when it is used on expressways or freeways.

It is always your responsibility to safely operate the vehicle and avoid collisions.



Do not use Traffic Jam Assist in any of the following situations:

- You are traveling on a road with sharp curves.
  - » The system may not allow your vehicle to respond in a manner best suited for the road conditions.
- You are entering a toll booth, interchange, service area, or parking area.
- You are driving in adverse weather (rain, fog, snow, etc.).
- The surface of the road is slippery; for example, it is icy or covered with snow.
  - » The tires may slip, causing you to lose control of the vehicle.



If your vehicle veers too far to the right or the left of the white (or yellow) traffic lane lines while Traffic Jam Assist is active, deactivate Traffic Jam Assist and have your vehicle checked by a dealer.

## Lane Keep Support Function

When you are in heavy traffic and Lane Keeping Assist System (LKAS) is active, the traffic jam assist system, upon detecting the traffic lane lines, will apply steering torque to help keep your vehicle in the center of the lane.

- » When the driver takes full control of the steering, the steering assist function is temporarily canceled.
- » When the driver takes full control of the steering, the steering assist function is temporarily canceled. The torque applied to the steering may not be noticeable when the driver has full control of the steering, or when the surface of the road is rough or uneven.

## Lane Departure Warning Function

In some driving situations, when the system detects that the vehicle has departed from its lane, Traffic Jam Assist alerts you with slight steering wheel vibration and visual warnings.

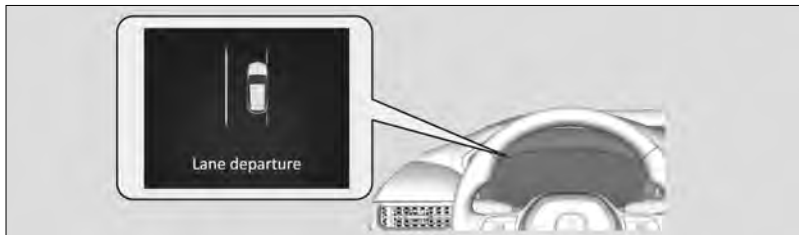

## Operating Conditions

- LKAS is activated.
- The lane in which you are driving has detectable lane markers on both sides, and your vehicle is in the center of the lane.
- You are driving on a straight or slightly curved road.
- The driver is gripping the steering wheel.
- The vehicle is traveling between about 0 and 45 mph (0 and 72 km/h).

Refer to the following for proper handling of LKAS:

[Q About LKAS ▶P.310](#)

Refer to the following for operating device and displays:

[Q Device for Operating Each Function and Gauge Content ▶P.279](#)

## How to Activate Traffic Jam Assist



Keep your vehicle near the center of the lane while driving.

» The LKAS indicator (1) changes from white to green, and white lines (2) change to green once the system starts operating after detecting the left and right lane markings.

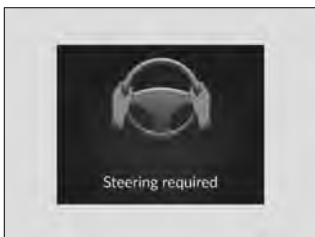

If the driver takes their hands off the steering wheel or does not adequately maintain control of steering, the warning display will appear. If the driver does not grip the steering wheel after the warning display has repeatedly appeared, a warning buzzer will sound and Traffic Jam Assist will be canceled.

## Cancelling Traffic Jam Assist

Press the  button to cancel Traffic Jam Assist.

» To operate Traffic Jam Assist, press the  button again.

## Traffic Jam Assist may be automatically suspended when:

- The system fails to detect lane lines.
- The steering wheel is turned sharply.
- You fail to steer the vehicle.
- You are driving through a sharp curve.
- The ABS, VSA®, CMBS™, or Low Speed Braking Control is activated.
- Your vehicle is driving to the right or the left of the lane.
- The brake pedal is suddenly depressed.

Once these conditions no longer exist, Traffic Jam Assist automatically resumes.



You can change the setting for the Traffic Jam Assist suspended beep on and off when you select the **Lane keeping assist suspend beep** on the driver information interface\* or the **Lane Keeping Assist Suspend Beep** on the audio/information screen\*.

▼ **Models with 9" Color Touchscreen**

🔍 Vehicle Settings ▶ P.352

▼ **Models with 9" Color Touchscreen with Google built-in**

🔍 Customized Features ▶ P.249

## Traffic Jam Assist Limitations

The system may not detect lane markings and therefore may not keep the vehicle in the middle of the lane under certain conditions, including the following:

### ■ Environmental conditions

- There is little contrast between lane lines and the roadway surface.
- Driving in bad weather (rain, fog, snow, etc.).
- Driving on a snowy or wet roadway.
- Driving into low sunlight (e.g., at dawn or dusk).
- Shadows of adjacent objects (trees, buildings, guard rails, vehicles, etc.) are parallel to white (or yellow) lines.
- Sudden changes between light and dark, such as the entrance or exit of a tunnel or the shadows of trees, buildings, etc.
- Driving at night or in a dark place such as a tunnel (due to low-light conditions, lane lines or the road surface may not be illuminated).
- When the lane lines or road surface are not visible, such as when the distance to the vehicle in front of you is extremely short or when at an intersection.
- Strong light is reflected onto the roadway.

### ■ Roadway conditions

- Driving on a road with temporary lane markings.
- Faint, multiple, or varied lane markings are visible on the roadway due to road repairs or deteriorated lane markings.
- The roadway has merging, split, or crossing lines, such as at an intersection or crosswalk.
- The lane markings are extremely narrow, wide, or changing.
- Part of the lane markings are hidden by an object, such as a vehicle.
- The road is hilly or the vehicle is approaching the crest of a hill.
- Your vehicle is strongly shaken on uneven road surfaces.
- When objects on the road (curb, guard rail, pylons, etc.) are recognized as white (or yellow) lines.

\*: Not available on all models

- Driving on rough or unpaved roads, or over bumpy surfaces.
- Driving on roads with double lane lines.
- Driving on snowy or slippery roads.
- The pavement is only partially visible due to snow or puddles on the road.
- There is a film of water or puddles on the road surface.
- White (or yellow) lines are not recognized correctly due to road conditions such as curves, twists, or hills.
- Driving on unpaved or rutted roads.
- Passing through an exit or an interchange.

### Vehicle conditions

- When lighting is weak due to dirt covering the headlight lenses, or there is poor visibility in a dark place due to the headlights being improperly adjusted.
- The front of the camera is obstructed by dirt, fog, rain, mud, wet snow, accessories, decals, stickers, film, etc.
- Driving at night or in a dark place (e.g., a tunnel) with the headlights off.
- There is residue on the windshield from the windshield wipers.
- The inside of the windshield is fogged.
- An abnormal tire or wheel condition (incorrect sizes, varied sizes or construction, improperly inflated, compact spare tire\*, etc.).
- The vehicle is tilted due to a heavy load in the cargo area or rear seats.
- The suspension has been modified.

\*: Not available on all models

# Traffic Sign Recognition System

## About Traffic Sign Recognition System

While driving, road signs (such as speed limit signs) detected by the front wide view camera are displayed on the gauge to inform you of road sign information.

Q Front Wide View Camera ▶ P.280



When the camera detects traffic signs while the vehicle is being driven, the system displays recognized signs in your vehicle for a programmed time and distance. If a speed limit sign (1) is detected and the vehicle exceeds the speed limit by a programmed threshold, the speed limit sign icon will blink.

» If the system does not detect any traffic signs while you are driving, the sign icon will not be displayed.

- Not all signs may be displayed, but any signs posted on roadsides should not be ignored. The system does not work on the designated traffic signs of all the countries you travel, nor in all situations. Do not rely too much on the system. Always drive at speeds appropriate for the road conditions.
- Never apply a film or attach any objects to the windshield that could obstruct the camera's field of vision and cause the system to operate abnormally. Scratches, nicks, and other damage to the windshield within the camera's field of vision can cause the system to operate abnormally. If this occurs, we recommend that you replace the windshield with a Genuine Acura replacement windshield. Making even minor repairs within the camera's field of vision or installing an aftermarket replacement windshield may also cause the system to operate abnormally. After replacing the windshield, have a dealer recalibrate the camera. Proper calibration of the camera is necessary for the system to operate properly.
- If the system does not detect any traffic signs while you are driving, the sign icon will not be displayed.
- To help reduce the likelihood that high interior temperatures will cause the camera's sensing system to shut off, find a shady area or face the front of the vehicle away from the sun when parking. If you use a reflective sun shade, do not allow it to cover the camera housing. Covering the camera can concentrate heat on it.
- The system's ability to accurately notify the driver of the speed limit is dependent on certain conditions such as the units displayed on the traffic sign as well as the speed and direction of travel of the vehicle. In some cases, the system may display false warnings or other inaccurate information.





You can turn the Traffic Sign Recognition System on and off.

▼ **Models with 9" Color Touchscreen**

🔍 Vehicle Settings\* ▶ P.352

▼ **Models with 9" Color Touchscreen with Google built-in**

🔍 Customized Features ▶ P.249



If your vehicle exceeds the detected speed limit, an icon representing the speed limit sign for the current area will blink in the display.

▼ **Models with 9" Color Touchscreen**

🔍 Vehicle Settings\* ▶ P.352

▼ **Models with 9" Color Touchscreen with Google built-in**

🔍 Customized Features ▶ P.249



The unit for speed limits (mph or km/h) varies from country to country. Just after entering a country whose unit differs from the one of the country from which you came, The Traffic Sign Recognition System may not work correctly.

▼ **Models with 9" Color Touchscreen**

🔍 Vehicle Settings\* ▶ P.352

▼ **Models with 9" Color Touchscreen with Google built-in**

🔍 Customized Features ▶ P.249



When the traffic sign recognition system malfunctions,  appears on the gauge. If this icon does not disappear, have your vehicle checked by a dealer.

## Operating Conditions

The sign icon also may switch to another one or disappear when:

- The other designated limit is detected.
- You make a turn with a turn signal at an intersection.

## Traffic Sign Recognition System Limitations

The Traffic Sign Recognition system may incorrectly recognize, be slow to identify, or fail to recognize the traffic sign in the following cases.

\*: Not available on all models

## Environmental conditions

- Driving into low sunlight (e.g., at dawn or dusk).
- Strong light is reflected onto the roadway.
- Driving at night or in dark areas such as long tunnels.
- Driving in bad weather (rain, fog, snow, etc.).
- Sudden changes between light and dark, such as the entrance or exit of a tunnel or the shadows of trees, buildings, etc.
- Water is sprayed by or snow blown from a vehicle ahead.

## Roadway conditions

- Your vehicle is strongly shaken on uneven road surfaces.

## Vehicle conditions

- When lighting is weak due to dirt covering the headlight lenses, or there is poor visibility in a dark place due to the headlights being improperly adjusted.
- The front of the camera is obstructed by dirt, fog, rain, mud, wet snow, accessories, decals, stickers, film, etc.
- Driving at night or in a dark place (e.g., a tunnel) with the headlights off.
- There is residue on the windshield from the windshield wipers.
- The inside of the windshield is fogged.
- An abnormal tire or wheel condition (incorrect sizes, varied sizes or construction, improperly inflated, compact spare tire\*, etc.).
- The vehicle is tilted due to heavy load in the cargo area or rear seats.
- The suspension has been modified.

## The position or the condition of the traffic sign

- The sign is in a place that makes it hard to find.
- The sign is located far away from your vehicle.
- The sign is located where it is hard for headlight beams to reach.
- The sign is on a corner or bend in the road.
- The sign is faded or bent.
- The sign is rotated or damaged.
- The sign is covered with mud, snow, or frost.
- Part of the sign is hidden by the trees, or is in the shadow of a vehicle or other object.
- Light (such as a streetlight) is reflected on the surface of the sign, or it is hidden in shadow.
- The sign is too bright or too dark (electric signs).
- Small signs (auxiliary signs, etc.).

## Other conditions

- When you are driving at a high speed.

\*: Not available on all models

The Traffic Sign Recognition System may not operate correctly, such as displaying signs that do not adhere to the actual regulations for the roadway or do not exist at all in the following cases.

- » A speed limit sign may display at a higher or lower speed than the actual speed limit.
- There is a supplementary sign with further information such as weather, time, vehicle type, school zone, etc.
- Figures on the sign are hard to read (electric signs, numbers on the sign are blurred, etc.).
- The sign is in the vicinity of the lane you are driving in, even though it is not for the lane, such as a speed limit sign situated at an exit or an intersection between the side road and the main road.
- There are things that look similar in color or shape to recognized objects (similar sign, electric sign, signboard, structure, etc.).

# Blind Spot Information System

## About Blind Spot Information System

When the system detects vehicles approaching from behind in adjacent lanes, the appropriate indicator comes on, providing assistance when you change lanes.



When the system detects a vehicle, the blind spot information system alert indicator (1) on the outside door mirror on both sides comes on in the following situations:

- A vehicle approaches you from behind to overtake you at a speed difference of no more than about 31 mph (50 km/h).
- You pass a vehicle at a speed difference of no more than about 12 mph (20 km/h).

When you operate the turn signal lever in the direction of a detected vehicle, the blind spot information indicator blinks and the beeper sounds.



You can change the setting for the blind spot information system.

### ▼ Models with 9" Color Touchscreen

🔍 Vehicle Settings ▶ P.352

### ▼ Models with 9" Color Touchscreen with Google built-in

🔍 Customized Features ▶ P.249

## Important Safety Reminder

Like all assistance systems, the blind spot information system has limitations. Always look in your mirrors, to either side of your vehicle, and behind you for other vehicles before changing lanes. Overreliance on the blind spot information system may result in a collision.

## System Operation

The system activates when your vehicle is moving forward at about 20 mph (32 km/h) or above.

\*: Not available on all models

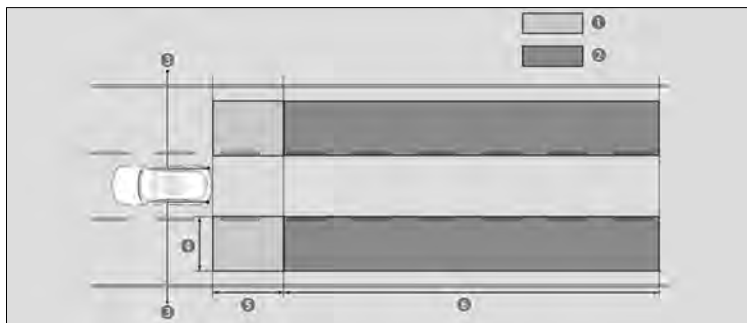

1 Alert Zone 1

2 Alert Zone 2

3 Radar sensors: underneath the rear bumper corners

4 1.6 ~ 10 feet (0.5 ~ 3 meters) from vehicle side.

5 10 feet (3 meters) from rear bumper.

6 10 ~ 82 feet (3 ~ 25 meters) behind from rear bumper. (The faster the approaching vehicle, the further away it will be detected.)

- The initially set alert zone is alert zone 1. Over time, after the vehicle has been driven on straight roads with traffic and roadside objects, the system will adapt and expand the alert zone (alert zone 1 and 2).
- If the rear bumper or any system components are repaired, the system will revert to alert zones 1 only until it is able to adapt and expand to alert zone 1 and 2.

## Blind Spot Information System On and Off

You can turn the system on and off using the driver information interface.

Q Switching the Display ▶P.346

Q Safety Support ▶P.350

- The blind spot information system will stay on the previously selected on or off setting each time you start the engine.

## Blind Spot Information System Limitations

### For proper blind spot information system operation:

- Always keep the rear bumper and area around the radar sensors clean.
- Do not cover the rear bumper corner area with labels or stickers of any kind.

### The blind spot information system alert indicator may not come on under the following conditions:

- There is a large speed difference between your vehicle and the vehicle in the adjacent lane.

- A vehicle is parked in a side lane.
- An object not detected by the radar sensors approaches or passes your vehicle.
- The vehicle driving in the adjacent lane is a motorcycle or other small vehicle.

**The blind spot information system may not operate correctly under the following conditions:**

- Making a turn at an intersection.
- Objects (guard rails, poles, trees, etc.) are detected.
- An object that does not reflect radio waves well or a motorcycle is in the alert zone.
- Driving on a curved road.
- A vehicle is moving from a far lane to an adjacent lane.
- The system picks up signal interference such as other radar sensors from another vehicle or strong radio wave transmitted from a facility nearby.
- The rear bumper or the area around the radar sensors is obstructed by dirt, mud, snow, ice, etc.
- The rear bumper or the area around the radar sensors has been damaged or deformed.
- In bad weather (heavy rain, snow, and fog).
- Making a short turn or driving on a bumpy road that slightly tilts the vehicle.
- An object such as a bicycle rack is attached to the rear of the vehicle.



Have your vehicle checked by a dealer if the rear bumper or area around the radar sensors is strongly impacted, or if the rear bumper or any system components need to be repaired.

# Cross Traffic Monitor

## About Cross Traffic Monitor

Monitors the rear corner areas using the radar sensors when reversing, and alerts you if a vehicle approaching from a rear corner is detected.

The system is convenient when you are backing out of a parking space.

### ⚠ CAUTION

Cross Traffic Monitor cannot detect all approaching vehicles and may not detect an approaching vehicle at all.

Failure to visually confirm that it is safe to back up the vehicle before doing so may result in a collision.

Do not solely rely on the system when reversing; always also use your mirrors, and look behind and to the sides of your vehicle before reversing.

## System Operation

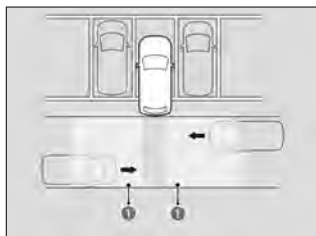

### 1 Detection Range

When the vehicle speed is less than about 3 mph (5 km/h), the shift position is in **R**, and the system is ON, the system will detect vehicles approaching from either rear corner and alert you with a buzzer and a visual indication.

The system will not detect a vehicle that approaches from directly behind your vehicle, nor will it provide alerts about a detected vehicle when it moves directly behind your vehicle.

The system does not provide alerts for a vehicle that is moving away from your vehicle, and it may alert for pedestrians, bicycles, or stationary objects.

## About Screen Display

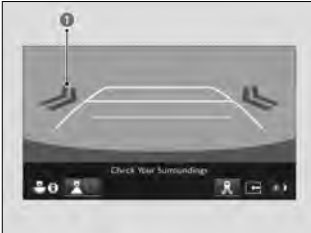

### ▼ Models with 9" Color Touchscreen with Google built-in

An arrow icon (1) appears on the side a vehicle is approaching.



### ▼ Models with 9" Color Touchscreen



- If the  changes to  in amber when the transmission is in **R**, mud, snow or ice, etc. may have accumulated in the vicinity of the sensor. The system is temporarily canceled. Check the bumper corners for any obstructions, and thoroughly clean the area if necessary.
- If the  comes on when the transmission is in **R**, there may be a problem with the Cross Traffic Monitor system. Do not use the system and have your vehicle checked by a dealer.
- If the display remains the same with the transmission in **R**, there may be a problem with the rear camera system and the Cross Traffic Monitor system. Do not use the system and have your vehicle checked by a dealer.



## Cross Traffic Monitor On and Off

### ▼ Models with 9" Color Touchscreen with Google built-in

The system can be turned on and off on the audio/information screen by selecting the Cross Traffic Monitor icon (1).



### ▼ Models with 9" Color Touchscreen



You can also switch the system on and off using the audio/information screen.

#### ▼ Models with 9" Color Touchscreen

🔍 Customized Features ▶ P.214

#### ▼ Models with 9" Color Touchscreen with Google built-in

🔍 Customized Features ▶ P.249

## Cross Traffic Monitor Limitations

Cross Traffic Monitor may not detect or may delay detecting an approaching vehicle, or may alert detection without an approaching vehicle under the following conditions:

- An obstacle, such as another vehicle or a wall near your vehicle's rear bumper, is blocking the radar sensor's scope.
- Your vehicle is moving at a speed of about 3 mph (5 km/h) or higher.
- A vehicle is approaching at a speed other than between about 6 mph (10 km/h) and 16 mph (25 km/h).
- The system picks up external interference such as other radar sensors from another vehicle or strong radio waves transmitted from a facility nearby.

- Either corner of the rear bumper is covered with snow, ice, mud or dirt.
- When there is bad weather.
- Your vehicle is on an incline.
- Your vehicle is tilted due to a heavy load in the rear.
- Your vehicle is reversing towards a wall, a pole, a vehicle, and so on.
- Driving on snowy or slippery roads.

 If the rear bumper or the sensors have been improperly repaired or the rear bumper has been deformed, have your vehicle checked by a dealer.

 For proper operation, always keep the rear bumper corner area clean. Do not cover the rear bumper corner area with labels or stickers of any kind.

# Parking Sensor System\*

## About Parking Sensor System

The corner and center sensors monitor obstacles around your vehicle, and the beeper and display let you know the approximate distance between your vehicle and the obstacle.

 Sonar Sensors ▶P.281



Even when the system is on, always confirm if there is no obstacle near your vehicle before parking.

## The Sensor Location and Range

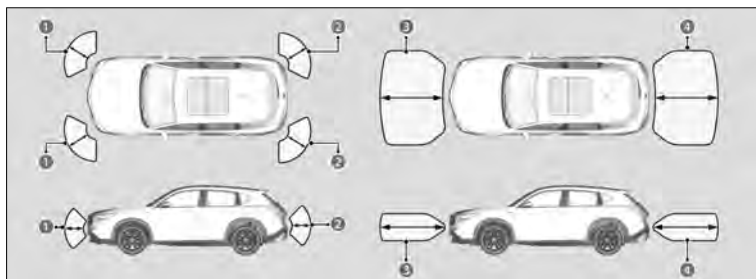

- ① Front Corner Sensors
- ② Rear Corner Sensors
- ③ Front Center Sensors
- ④ Rear Center Sensors

## Parking Sensor System On and Off

You can turn the system on and off using the driver information interface.

 Switching the Display ▶P.346

 Safety Support ▶P.350

- The system is in the previously selected on or off setting each time you turn the engine on.



You can turn the rear parking sensor system on and off.

 Customized Features ▶P.249

\*: Not available on all models

## Screen Operation



You can switch between split view off (1) and split view on (2) by touching the split screen tab (3).

## Operations When an Obstacle Has Been Detected

The front corner, rear corner, and rear center sensors start to detect an obstacle when the transmission is in **R**, and the vehicle speed is less than 5 mph (8 km/h).

The front corner and front center sensors start to detect an obstacle when the shift position is in any position other than **P** or **R**, and the vehicle speed is less than 5 mph (8 km/h).

» When the system detects that the distance between your vehicle and any obstacles in front of it is decreasing, the forward camera image\* will display on the screen. When obstacles are no longer detected, the display will return to the previous screen.



You can customize whether or not to display the forward camera image when an obstacle is detected.

Customized Features ▶ P.249



The indicators show the location of the detected location on the driver information interface.

**1** Indicator

\*: Not available on all models

The indicators (1) also show the position of the detected location on the audio/information screen.



Color of Indicator	Interval between beeps	Distance between the Bumper and Obstacle	
		Corner Sensors	Center Sensors
Yellow <sup>*1</sup>	Moderate	-	Front: About 33-26 in (85-65 cm) Rear: About 43-24 in (110-60 cm)
Amber	Short	About 24-18 in (60-45 cm)	Front: About 26-22 in (65-55 cm) Rear: About 24-18 in (60-45 cm)
	Very short	About 18-14 in (45-35 cm)	Front: About 22-18 in (55-45 cm) Rear: About 18-14 in (45-35 cm)
Red	Continuous	About 14 in (35 cm) or less	Front: About 18 in (45 cm) or less Rear: About 14 in (35 cm) or less

\*1: When the indicator is yellow, only the center sensors detect obstacles.

To temporarily turn off the beeper, press the right selector wheel while it is sounding. Temporary OFF will be canceled when the shift position is switched or the vehicle speed reaches 9mph (14km/h) or higher.

## Parking Sensor System Limitations

The system may not work properly when:

- The sensors are covered with snow, ice, mud, or dirt.
- The vehicle has been out in hot or cold weather.
- There is something nearby that emits ultrasonic waves or high frequency sounds.
- Driving in bad weather (rain, fog, snow, etc.).

The system may not detect these obstacles:

- Thin or low objects.

- Sonic-absorptive materials, such as snow, cotton, or sponge.
- Objects directly under the bumper.

The system may falsely detect obstacles in the following situations:

- The vehicle is on uneven surface, such as grass, bumps, or a hill.
- When close to other vehicles with sonar sensors or other objects that emit ultrasonic waves.
- There is splashing water near the sensors due to heavy rains, etc.



Do not put any accessories on or around the sensors.

If you put any accessories (such as a bicycle rack) on or around the rear sensors, the system may activate if it detects these accessories as an obstacle. In this case, turn off the rear sensor.

 Customized Features ▶ P.249

# About Your Instrument Panel

## **Indicators**

Indicator List..... 335

When Indicators Come On/Blink..... 337

## **Gauges**

Types of Gauges..... 342

## **Driver Information Interface**

About the Driver Information Interface..... 346

Driver Information Interface Right Side Area... 346

Driver Information Interface Left Side Area... 355

# Indicators

## Indicator List

<p><b>▼ U.S.</b> *1</p> <p><b>BRAKE</b></p> <p>Parking Brake and Brake System Indicator (Red) Q, P.337</p>	<p><b>▼ Canada</b> *1</p>  <p>Parking Brake and Brake System Indicator (Red) Q, P.337</p>	<p><b>▼ U.S.</b> *1</p> <p><b>BRAKE SYSTEM</b></p> <p>Parking Brake and Brake System Indicator (Amber) Q, P.338</p>	<p><b>▼ Canada</b> *1</p>  <p>Parking Brake and Brake System Indicator (Amber) Q, P.338</p>	<p><b>Battery</b> *1</p>  <p>12-Volt Battery Charging System Indicator Q, P.338</p>
 <p>Seat Belt Reminder Indicator Q, P.338</p>	 <p>Supplemental Restraint System Indicator Q, P.338</p>	 <p>Malfunction Indicator Lamp Q, P.338</p>	 <p>Low Fuel Indicator Q, P.339</p>	 <p>Anti-lock Brake System (ABS) Indicator Q, P.339</p>
 <p>Vehicle Stability Assist™ (VSA®) System Indicator Q, P.339</p>	 <p>Vehicle Stability Assist™ (VSA®) OFF Indicator Q, P.339</p>	 <p>Electric Power Steering (EPS) System Indicator Q, P.340</p>	 <p>Low Tire Pressure/TPMS Indicator Q, P.340</p>	 <p>System Message Indicator Q, P.355</p>
 <p>Transmission System Indicator Q, P.340</p>	<p><b>D</b></p> <p>Shift Position Indicator Q, P.110</p>	<p><b>M 2</b></p> <p>M (7-speed manual shift mode) Indicator/Shift Indicator Q, P.110</p>	<p><b>NORMAL</b></p> <p>NORMAL Mode Indicator Q, P.152</p>	<p><b>COMFORT</b></p> <p>COMFORT Mode Indicator Q, P.152</p>
<p><b>SPORT</b></p> <p>SPORT Mode Indicator Q, P.152</p>	<p><b>SNOW</b></p> <p>SNOW Mode Indicator Q, P.152</p>	<p><b>INDIVIDUAL</b></p> <p>INDIVIDUAL Mode Indicator* Q, P.152</p>	 <p>Adaptive Cruise Control (ACC) with Low Speed Follow Interval Indicator Q, P.304</p>	 <p>Hill Descent Control System Indicator (White/Green) Q, P.159</p>

\*: Not available on all models



 <p>Automatic Brake Hold System Indicator Q, P.117</p>	<p>▼ U.S. *1</p>  <p>Automatic Brake Hold Indicator Q, P.117</p>	<p>▼ Canada *1</p>  <p>Automatic Brake Hold Indicator Q, P.117</p>	 <p>Cruise Mode Indicator (White/Green) Q, P.306</p>	 <p>Turn Signal Indicators Q, P.138</p>
 <p>Hazard Warning Indicators</p>	 <p>Lights On Indicator Q, P.138</p>	 <p>Auto High-Beam Indicator Q, P.141</p>	 <p>Fog Light Indicator* Q, P.141</p>	 <p>High Beam Indicator Q, P.140</p>
 <p>Auto Idle Stop System Indicator (Amber) Q, P.340</p>	 <p>Auto Idle Stop Indicator (Green) Q, P.154</p>	 <p>Auto Idle Stop OFF Indicator Q, P.156</p>	 <p>Auto Idle Stop Suspend Indicator Q, P.154</p>	 <p>Adaptive Cruise Control (ACC) with Low Speed Follow Indicator (Amber) Q, P.340</p>
 <p>Adaptive Cruise Control (ACC) with Low Speed Follow Indicator (White/Green) Q, P.279</p>	 <p>Lane Keeping Assist System (LKAS) Indicator (Amber) Q, P.340</p>	 <p>Lane Keeping Assist System (LKAS) Indicator (White/Green) Q, P.279</p>	 <p>Safety Support Indicator (Amber) Q, P.341</p>	 <p>Safety Support Indicator (Green/Gray) Q, P.350</p>
 <p>Immobilizer System Indicator Q, P.49</p>	 <p>Security System Alarm Indicator Q, P.50</p>			

\*1: When you set the power mode to ON, these indicators come on to indicate that system checks are being performed. They go off a few seconds later or after the engine has started. If an indicator does not come on or turn off, there may be a malfunction in the corresponding system. To resolve the issue, follow the instructions in the owner's manual.

\*: Not available on all models

## When Indicators Come On/Blink

Indicators come on/blink depending on the condition of the vehicle. Messages may be displayed at the same time. Please take the appropriate action outlined in the message, such as having your vehicle checked by a dealer.

If a message is displayed saying the vehicle cannot be driven, immediately stop in a safe place and contact a dealer.

After reconnecting the 12-volt battery, if multiple indicators come on and **Systems initializing** is displayed, drive a short distance at more than 12 mph (20 km/h). If the indicators do not go off, have your vehicle checked by a dealer.

▼ U.S.	▼ Canada	
<b>BRAKE</b>		
<b>Parking Brake and Brake System Indicator (Red)</b>		

Comes on when the parking brake is applied, and goes off when it is released.

Comes on when the brake fluid level is low.

- » Depress the brake pedal lightly to check pedal pressure.
- » If normal, check the brake fluid level the next time you stop.

 **Checking the Brake Fluid** ▶ P.374

- » If abnormal, take immediate action. If necessary, downshift the transmission to slow the vehicle using engine braking.
- Have your vehicle repaired immediately. It is dangerous to drive with low brake fluid. If there is no resistance from the brake pedal, stop immediately in a safe place. If necessary, downshift the gears.

Comes on if there is a problem with the brake system.

- If the Parking Brake and Brake System Indicator (Red) and Parking Brake and Brake System Indicator (Amber) come on simultaneously, the braking system may be less effective than usual. Make sure to depress the brake pedal firmly. Immediately stop in a safe place and contact a dealer.
- If the Parking Brake and Brake System Indicator (Red) and **ABS** indicator come on simultaneously, the electronic brake distribution system is not working. This can result in vehicle instability under sudden braking. Have your vehicle inspected by a dealer immediately.

Blinks if there is a problem with the electric parking brake.

- » Do not use the parking brake.
- » Put the transmission into **P** to prevent the vehicle from moving, as the parking brake may not work.
- If the Parking Brake and Brake System Indicator (Red) blinks at the same time when the Parking Brake and Brake System Indicator (Amber) comes on, the parking brake may not work. Avoid using the parking brake and have your vehicle checked by a dealer immediately.

▼ U.S.

▼ Canada

 **BRAKE  
SYSTEM****Parking Brake and Brake System Indicator (Amber)**

Comes on if there is a problem with a system related to braking other than the conventional brake system.

Comes on if there is a problem with the electric parking brake system and/or the automatic brake hold system.

» Do not use the parking brake.

**12-Volt Battery Charging System Indicator**

Comes on when there is a problem with the charging system.

**Seat Belt Reminder Indicator**

Comes on or blinks when any seat belts are unfastened.

» Securely fasten seat belts immediately.

- Comes on or blinks when a seat belt in the rear seat is unfastened. Turns off momentarily.
- If this indicator stays on after you and/or the passengers have fastened the seat belt(s), a detection error may have occurred in the sensor. Have your vehicle checked by a dealer.
- You can check whether each seat belt is fastened on the driver information interface.

 [Switching the Display](#) ▶ P.346

**Supplemental Restraint System Indicator**

Comes on if a problem with the airbag system or seat belt tensioners is detected.

 [About Your Airbags](#) ▶ P.33

**Malfunction Indicator Lamp**

After you have set the power mode to ON, the vehicle performs system checks.

However, if the readiness codes have not been set by that time, this indicator will blink five times and then go off.

» Readiness codes are part of the on-board diagnostics for the emissions control systems.

 [Testing of Readiness Codes](#) ▶ P.440

Comes on if there is a problem with the engine's emissions control systems.

- If you drive with the malfunction indicator lamp on, the emissions control system and the engine could be damaged.

Blinks when a misfire in the engine's cylinders is detected.

» Park the vehicle in a safe place with no flammable items and wait at least 10 minutes or more with the engine stopped until it cools.



### Low Fuel Indicator

Comes on when the fuel reserve is running low (approximately 2.1 U.S. gal/8.0 Liter left).

 [Range](#) ▶ P.346

Blinks if there is a problem with the fuel gauge.



### Anti-lock Brake System (ABS) Indicator

Comes on if there is a problem with the ABS.

- With this indicator on, your vehicle still has normal braking ability but no ABS function. This can result in vehicle instability under sudden braking, so avoid situations such as highway driving.



### Vehicle Stability Assist™ (VSA®) System Indicator

Blinks when VSA® is active.

Comes on if there is a problem with the VSA® system, brake assist system, hill start assist system, starting assist brake function, or agile handling assist.

- With this indicator on, your vehicle still has normal braking ability.



### Vehicle Stability Assist™ (VSA®) OFF Indicator

Comes on when you partially disable VSA®.

 [Vehicle Stability Assist™ \(VSA®\), aka Electronic Stability Control \(ESC\), System](#) ▶ P.160



### Electric Power Steering (EPS) System Indicator

Comes on if there is a problem with the EPS system.

» Stop your vehicle in a safe place. If this indicator stays on after restarting the engine, take your vehicle to a dealer for an inspection immediately.



### Low Tire Pressure/TPMS Indicator

Comes on if the tire pressure of any of the tires becomes low.

» Stop in a safe place, check tire pressures, and inflate the tire(s) if necessary.

If this indicator stays on after blinking, there is a problem with the TPMS with Tire Fill Assist.

#### ▼ Models with compact spare tire

- This indicator also comes on when a compact spare tire is installed.



### Transmission System Indicator

Blinks if the transmission system has a problem.



### Auto Idle Stop System Indicator (Amber)

Blinks if there is a problem with the Auto Idle Stop system.



### Adaptive Cruise Control (ACC) with Low Speed Follow Indicator (Amber)

Comes on if there is a problem with ACC with Low Speed Follow.

- Comes on if the vehicle is tilted due to heavy luggage in the cargo space or rear seats.



### Lane Keeping Assist System (LKAS) Indicator (Amber)

Comes on if there is a problem with the LKAS.

- Comes on if the vehicle is tilted due to heavy luggage in the cargo space or rear seats.



## Safety Support Indicator (Amber)

Comes on if there is a problem with any of the safety support systems.

About Safety Support ▶ P.350

- Comes on if the vehicle is tilted due to heavy luggage in the cargo space or rear seats.

### ▼ Models with parking sensor system

Comes on if there is a problem with the parking sensor.

- » Check if the area around the sensor(s) is covered with mud, ice, snow, etc.

About Parking Sensor System ▶ P.330

Comes on when driver assist system functions are limited because the camera's temperature is too high.

Front Wide View Camera ▶ P.280

Comes on when driver assist system functions are limited because of poor camera visibility due to poor weather such as rain, fog, snow; or due to dark surroundings such as in early morning, late evening, or the inside of a tunnel at night.

- Comes on when the area around the camera is covered by obstacles.

Front Wide View Camera ▶ P.280

Comes on when the blind spot information system's sensor is dirty.

- » Park in a safe place and check the vicinity of the blind spot information system sensor and remove any obstacles.

About Blind Spot Information System ▶ P.323

Comes on when the temperature of the blind spot information system sensor is high.

- » The system will return to normal when the temperature cools down.

### ▼ Models with Low Speed Braking Control

Comes on when the Low Speed Braking Control System's functions are limited because the sonar sensor is covered by obstacles.

Sonar Sensors ▶ P.281

About Low Speed Braking Control ▶ P.291

# Gauges

## Types of Gauges



- 1 Temperature Gauge
- 2 Tachometer
- 3 Traffic Sign Recognition System
- 4 Speedometer
- 5 Fuel Gauge
- 6 Odometer
- 7 Current Mode for Adaptive Cruise Control (ACC) with Low Speed Follow, the Lane Keeping Assist System (LKAS), and Traffic Jam Assist
- 8 Outside Temperature

## Speedometer

Displays your driving speed.

- You can change the Speed/Distance units.

[Q Speed/distance units](#) ▶ P.354

### ▼ Models with 9" Color Touchscreen

[Q Vehicle Settings\\*](#) ▶ P.352

### ▼ Models with 9" Color Touchscreen with Google built-in

[Q Customized Features](#) ▶ P.249

\*: Not available on all models

## ▼ U.S. models



- If you change the unit from miles and mph to km and km/h, the current vehicle speed in mph appears next to the digital speedometer.

## ① Vehicle Speed in mph

## Tachometer

Shows the number of engine revolutions per minute.

## Fuel Gauge

Displays the amount of fuel left in the fuel tank.

- You should refuel when the reading approaches **E**.
- Running out of fuel can cause the engine to misfire, damaging the catalytic converter.
- After lightly refueling, or depending on your vehicle's condition, the actual amount of remaining fuel may differ from the fuel gauge reading.

## Temperature Gauge

Displays the temperature of the engine coolant. Normally, the reading should not reach the **H** mark while driving.

Driving with the temperature gauge reading near the **H** can cause serious engine damage. Pull safely to the side of the road and allow engine temperature to return to normal.

[How to Handle Overheating](#) ▶ P.418

## Outside Temperature

Shows the outside temperature.

- The temperature sensor is in the front bumper.
- Your vehicle, surrounding vehicles, and road heat can affect the temperature reading when your vehicle speed is less than 19 mph (30 km/h). Also, the display is not updated until the temperature reading has stabilized. This may take several minutes.





You can adjust the temperature displayed on the gauge.

▼ **Models with 9" Color Touchscreen**

🔍 Vehicle Settings ▶ P.352

▼ **Models with 9" Color Touchscreen with Google built-in**

🔍 Customized Features ▶ P.249

## Traffic Sign Recognition System



Shows certain detected traffic signs while driving. If speed limit warning is activated, the sign icon blinks when the maximum speed of the traffic sign detected is exceeded by a threshold, when compared with the vehicle speed.

🔍 About Traffic Sign Recognition System ▶ P.319

- The default speed limit warning threshold is the maximum speed of the traffic sign detected.



You can adjust the threshold for speed limit warning.

▼ **Models with 9" Color Touchscreen**

🔍 Vehicle Settings ▶ P.352

▼ **Models with 9" Color Touchscreen with Google built-in**

🔍 Customized Features ▶ P.249

## Current Mode for Adaptive Cruise Control (ACC) with Low Speed Follow, the Lane Keeping Assist System (LKAS), and Traffic Jam Assist

Shows the current mode for ACC with Low Speed Follow, LKAS, and Traffic Jam Assist.

🔍 About ACC with Low Speed Follow ▶ P.300

🔍 About LKAS ▶ P.310

🔍 About Traffic Jam Assist ▶ P.314

\*: Not available on all models

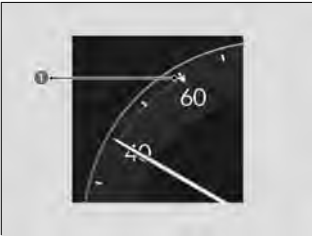

- When you set speed for ACC with Low Speed Follow or cruise control, a set speed mark will be displayed on the speedometer.

## 1 Set Speed

## Odometer

---

Shows the total distance that your vehicle has traveled.

# Driver Information Interface

## About the Driver Information Interface



1 Driver Information Interface  
Left Side Area

2 Driver Information Interface  
Right Side Area

The driver information interface shows your vehicle's condition and alerts you with a warning message when an abnormality is detected.

When a warning message displays, please check the message and contact a dealer to have the vehicle inspected if necessary.

Please refer to the pages below if the **Engine oil pressure low** or **Engine temperature too hot** message is displayed.

Q If the Engine oil pressure low. Warning Appears  
▶ P.420

Q How to Handle Overheating ▶ P.418

## Driver Information Interface Right Side Area

### Switching the Display



1 Right Selector Wheel

Roll the right selector wheel to view different types of content.

- You can add or delete the meter contents.

Q Gauge Display Settings ▶ P.354

### Range

Shows the estimated distance you can travel on the remaining fuel. This estimated distance is based on the vehicle's current fuel economy.

- The driving range displayed is only an estimate and may differ from the actual distance the vehicle can travel.

## Average Fuel Economy

Shows the average fuel economy for trip meters A and B in set intervals.

- The average fuel economy displayed may differ from the amount consumed while actually driving.
- If it was reset while parked or driving at a low speed, calculation of fuel economy will start after you resume normal driving.

## Instant Fuel Economy

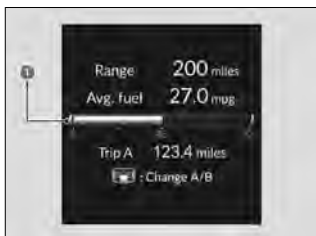

Shows the instant fuel economy as a bar graph.

### 1 Instant Fuel Economy

## Trip Meter

Shows the total distance driven since the last reset.

Press the right selector wheel to switch between trip meter A and trip meter B.

Meters A and B can be used to measure two separate trips.

- To reset the trip meter, display it, press and hold the right selector wheel, and then select **Reset**. The trip meter is reset to 0.0. Additionally, average fuel economy, average speed, and elapsed time will also be reset.
- When the trip meter exceeds 9999.9 miles or kilometers, it resets to 0.0.



The trip meter can reset automatically after refueling.

▼ **Models with 9" Color Touchscreen**

🔍 Vehicle Settings ▶ P.352

▼ **Models with 9" Color Touchscreen with Google built-in**

🔍 Customized Features ▶ P.249

## Average Speed

Shows the average speed since Trip A or Trip B was reset.

## Elapsed Time

Shows the time elapsed since Trip A or Trip B was reset.

\*: Not available on all models

## Navigation\*

### Compass

Shows the compass screen.

### Turn-by-Turn Directions

When driving guidance is provided by Google Maps, Apple CarPlay, or Android Auto, turn-by-turn directions to your destination appear.

Q Google built-in ▶ P.240

Q Apple CarPlay ▶ P.234

Q Android Auto™ ▶ P.237

- Navigation features may not be available for all devices or apps.



You can select whether to have the turn-by-turn display come on or not during the route guidance.

Q Customized Features ▶ P.249

## Driver Attention Monitor

The Driver Attention Monitor analyzes steering inputs to determine if the vehicle is being driven in a manner consistent with drowsy or inattentive driving. If it determines that the vehicle is being driven in such a manner, it will display the degree of the driver's attention on the driver information interface.



When you select **Driver attention** on the driver information interface, bars on it light up in white to indicate the degree of the driver's attention.

Q Switching the Display ▶ P.346

### 1 Level



If two bars light up, the **Driver attention level low** message will appear.

\*: Not available on all models

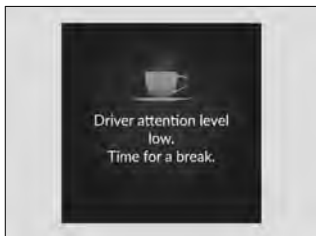

If one bar lights up, the **Driver attention level low. Time for a break** message will appear, a beep will sound, and the steering wheel will vibrate.

If this message appears, stop in a safe location and rest for as long as needed.

The message will disappear when the right selector wheel is rolled or when the system has determined that the driver is driving normally.

If the driver does not take a break and the monitor continues to detect that the driver is very tired, the message will appear again after approximately 15 minutes, accompanied by a beep and steering wheel vibrations.

The message does not appear when the traveling time is 30 minutes or less.

- The Driver Attention Monitor cannot always detect if the driver is tired or inattentive.
- Regardless of the system's feedback, if you are feeling tired, stop in a safe location and rest for as long as needed.



You can change the system settings.

▼ **Models with 9" Color Touchscreen**

🔍 Vehicle Settings ▶ P.352

▼ **Models with 9" Color Touchscreen with Google built-in**

🔍 Customized Features ▶ P.249

## ■ The Driver Attention Monitor resets when:

- The engine is turned off.
- The driver unfastens the seat belt and opens the door while the vehicle is stopped.

## ■ For the Driver Attention Monitor to function:

- The vehicle must be traveling above 25 mph (40 km/h).
- The electric power steering (EPS) system indicator must be off.
- The bars on the driver information interface remain grayed-out unless the Driver Attention Monitor is functioning.

\*: Not available on all models

## **Depending on driving conditions or other factors, the Driver Attention Monitor may not function in the following circumstances:**

- The steering assist function of the Lane Keeping Assist System (LKAS) or Traffic Jam Assist is active.

 [About LKAS](#) ▶ P.310

 [About Traffic Jam Assist](#) ▶ P.314

- The condition of the road is poor; e.g., the surface is unpaved or bumpy.
- It is windy.
- The driver is frequently operating the vehicle in an assertive manner, such as changing lanes or accelerating.

## **AWD Torque Distribution Monitor\***

The indicators on the display show the amount of torque being transferred to the right front, left front, right rear, and left rear wheels.

 [All-Wheel Drive \(AWD\) with Intelligent Control System\\*](#) ▶ P.161

## **Seat Belts**

Occurs, under specified conditions, when seat belts are latched or unlatched.

 [Seat Belt Reminder](#) ▶ P.78

## **Maintenance**

Shows the remaining oil life and Maintenance Minder™.

 [About Maintenance Minder™](#) ▶ P.361

## **Tire Pressure Monitor**

Shows each tire's pressure.

 [Tire Pressure Monitoring System \(TPMS\) with Tire Fill Assist](#) ▶ P.162

## **Safety Support**

Safety Support indicates the operating status of the following systems.

\*: Not available on all models

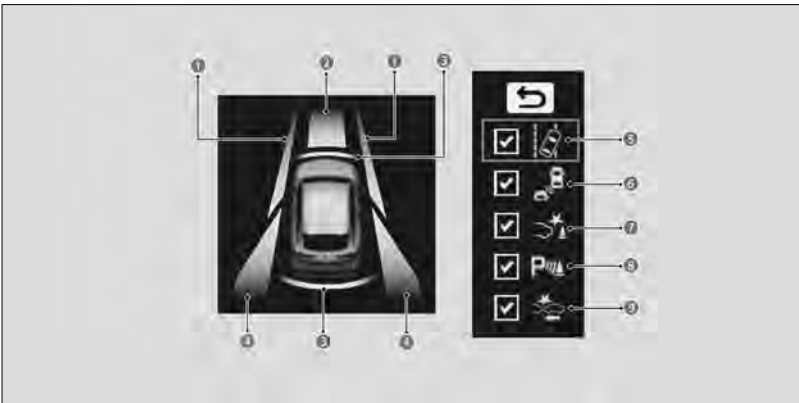

- 1 Operating Status for Road Departure Mitigation System
- 2 Operating Status for CMBS™
- 3 Operating Status for Low Speed Braking Control\* and Parking Sensor System
- 4 Operating Status for Blind Spot Information System
- 5 Road Departure Mitigation System
- 6 Blind Spot Information System
- 7 Low Speed Braking Control\*
- 8 Parking Sensor System
- 9 CMBS™

The following colors indicate the status of any of the above-mentioned systems:

- Green: The system is on.
- Gray: The system is off.
- Amber: There is a problem with the system.

- To turn each system on or off, first press the right selector wheel to switch displays. From the next display, you can select which system to turn on or off.

[Q About CMBS™ ▶P.284](#)

[Q About Low Speed Braking Control ▶P.291](#)

[Q About Road Departure Mitigation System ▶P.296](#)

[Q About Blind Spot Information System ▶P.323](#)

[Q About Parking Sensor System ▶P.330](#)

- When all features are ON, the  safety support indicator lights up in green. It lights up in green/gray when one or some of the features are ON, and it lights up in gray when all features are OFF.
- See below if the indicator lights up in amber.

[Q Safety Support Indicator \(Amber\) ▶P.341](#)

\*: Not available on all models



### ▼ Models with Low Speed Braking Control

- Even when the Low Speed Braking Control icon is green, if the **Rear Sensor Setting** is turned off, the brake assist will not operate when reversing.

🔍 Customized Features ▶ P.249

- Even when the parking sensor system icon is green, if the **Rear Sensor Setting** is turned off, the rear parking sensor will not operate when reversing.

🔍 Customized Features ▶ P.249

## Brightness

Display the adjustment for instrument panel brightness.

When the power mode is in ON, you can use the right selector wheel to adjust instrument panel brightness.

**Brighten:** Roll the right selector wheel up.

**Dim:** Roll the right selector wheel down.

Press the right selector wheel to exit.

- The brightness of the gauge is automatically adjusted depending on the ambient brightness.
  - » The brightness decreases when the ambient light is dark.
  - » The brightness increases when the ambient light is bright.
- You can change the setting even when the ambient lighting is bright, but the brightness of the gauge won't change.

## Vehicle Settings\*

### ■ How to change settings

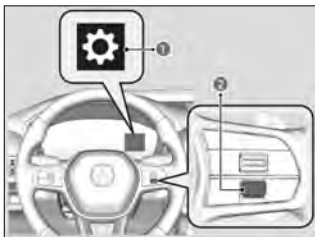

Select the  screen by rolling the right selector wheel while the power mode is in ON and the shift position is in **P**. After pressing the right selector wheel, select the settings you wish to change.

1 Driver Information Interface

2 Right Selector Wheel

### ■ Setting items

**Driver assist system setup**

**Forward collision warning distance**

Long/Normal<sup>1</sup>/Short

**ACC forward vehicle detect beep**

ON/OFF<sup>1</sup>

\*: Not available on all models

**Road departure mitigation setting**

Narrow/Normal<sup>\*1</sup>/Wide/Warning Only

**Lane keeping assist suspend beep**

ON/OFF<sup>\*1</sup>

**Blind spot information**

Audible and visual alert<sup>\*1</sup>/Visual alert

**Traffic sign recognition system display setting**

ON<sup>\*1</sup>/OFF

**Traffic sign recognition system exceeding speed warning**

ON/OFF<sup>\*1</sup>

**Speed limit warning threshold setting**

Speed limit<sup>\*1</sup>/Speed limit +3mph/  
Speed limit +5mph/Speed limit  
+10mph (U.S.)

Speed limit<sup>\*1</sup>/Speed limit +5km/h/  
Speed limit +10km/h/Speed limit  
+15km/h (Canada)

**Driver attention monitor**

Tactile and audible alert<sup>\*1</sup>/Tactile  
alert/OFF

**Meter setup**

**Language selection**

English<sup>\*1</sup>/Français/Español

**Adjust outside temp. display**

-5 °F ~ ±0 °F<sup>\*1</sup> ~ +5 °F (U.S.)

-3 °C ~ ±0 °C<sup>\*1</sup> ~ +3 °C (Canada)

**“Trip A” reset timing**

When fully refueled/IGN OFF/  
Manually reset<sup>\*1</sup>

**“Trip B” reset timing**

When fully refueled/IGN OFF/  
Manually reset<sup>\*1</sup>

**Adjust alarm volume**

High/Mid<sup>\*1</sup>/Low

**Rear seat reminder**

ON<sup>\*1</sup>/OFF

**Speed/distance units**

km/h · km/mph · miles<sup>\*1</sup> (U.S.)

km/h · km<sup>\*1</sup>/mph · miles (Canada)

**Keyless access setup**

**Door unlock mode**

Driver door only<sup>\*1</sup>/All doors

**Keyless access light flash**

ON<sup>\*1</sup>/OFF

**Keyless access beep**

ON<sup>\*1</sup>/OFF

**Remote start system ON/OFF\***

ON<sup>\*1</sup>/OFF

**Lighting setup**

**Auto high-beam**

ON<sup>\*1</sup>/OFF

**Interior light dimming time**

60sec/30sec<sup>\*1</sup>/15sec

**Headlight auto off timer**

60sec/30sec/15sec<sup>\*1</sup>/0sec

**Auto light sensitivity\***

Max/High/Mid<sup>\*1</sup>/Low/Min

**Auto headlight ON with wiper ON**

ON<sup>\*1</sup>/OFF

\*: Not available on all models

**Door setup****Auto door lock**

With vehicle speed<sup>\*1</sup>/Shift from P/  
OFF

**Auto door unlock**

All doors when driver's door opens<sup>\*2</sup>/  
All doors when shifted to Park/All  
doors when ignition switched OFF/  
OFF

**Walk away auto lock**

ON/OFF<sup>\*1</sup>

**Keyless lock answer back**

ON<sup>\*1</sup>/OFF

**Keyless remote power window control**

ON<sup>\*1</sup>/OFF

**Lockout prevention**

ON<sup>\*1</sup>/OFF

**Lock presetting**

ON<sup>\*1</sup>/OFF

**Power tailgate setup****Keyless open mode**

Anytime<sup>\*1</sup>/When unlocked

**Power open by outer handle**

ON (Power/Manual)<sup>\*2</sup>/OFF (Manual  
only)

**Climate control setup****Driver seat automatic climate control**

ON<sup>\*1</sup>/OFF

**Passenger seat automatic climate control**

ON<sup>\*1</sup>/OFF

**Maintenance reset**

(Selects Reset Items)

**Default all**

Cancel/Set

\*1: Default Setting

**Gauge Display Settings****Speed/distance units**

Enables you to set the displayed measurements to read in either miles and mph or km and km/h.

- [1] Press the right selector wheel when you select the **Gauge display settings** on the driver information interface.
- [2] Roll the right selector wheel to scroll to select **Speed/distance units**, then press the right selector wheel.
- [3] Roll the right selector wheel to scroll to select your desired settings, then press the right selector wheel.

**Arrange content on the right side area**

You can choose which contents to display on the right side area.

- [1] Press the right selector wheel when you select the **Gauge display settings** on the driver information interface.

- [2] Roll the right selector wheel to scroll to select **Hide/show**, then press the right selector wheel.
- [3] Roll the right selector wheel to scroll between contents, then press the right selector wheel to check or uncheck them.
  - Contents that are gray cannot be removed from the right side area.
  - When you customize settings, shift to **P**.

## Warnings

You can check if there are any active warning messages.

- If there are multiple warnings, you can roll the right selector wheel to see other warnings.
- When there is a warning message, the  system message indicator lights up.

## Driver Information Interface Left Side Area

Shows the current mode for audio and phone information, etc.

 Audio Remote Controls ▶ P.193

### ▼ Models with 9" Color Touchscreen

 Bluetooth® HandsFreeLink® ▶ P.209

### ▼ Models with 9" Color Touchscreen with Google built-in

 Bluetooth® HandsFreeLink® ▶ P.244

## Clock

Shows the clock.

- You can choose whether the clock is displayed on the driver information interface.

 Customize Display ▶ P.355

### ■ Clock Setup

Manual time adjustment is not necessary because the clock is using satellite information.

For details on other settings, please refer to the Navigation or Audio instruction manuals for your vehicle.

## Customize Display

- When you customize settings, shift to **P**.

## ■ Arrange audio source on the left side area

You can choose which sources to display on the audio source screen.

- [1] Roll the left selector wheel until **Customize display** is selected, then press the left selector wheel.
- [2] Roll the left selector wheel to scroll to select **Hide/show**, then press the left selector wheel.
- [3] Roll the left selector wheel to scroll between audio sources, then press the left selector wheel to check or uncheck them.

## ■ Turn the displaying on the left side area on and off

You can select whether the current audio information and clock appear on the left side area.

- [1] Roll the left selector wheel until **Customize display** is selected, then press the left selector wheel.
- [2] Roll the left selector wheel to scroll to select **Audio & clock**, then press the left selector wheel.
- [3] Roll the left selector wheel to scroll to select your desired settings, then press the left selector wheel.

## Before Performing Maintenance

Inspection and Maintenance	358
Maintenance Safety	359
Vehicle Safety	359

## Maintenance Minder™

About Maintenance Minder™	361
To Use Maintenance Minder™	361

## Maintenance Under the Hood

Maintenance Items Under the Hood	366
Opening the Hood	366
Recommended Engine Oil	368
Oil Check	369
Adding Engine Oil	369
Changing the Engine Oil and Oil Filter	370
Engine Coolant	371
Transmission Fluid	373
Brake Fluid	374
Refilling Window Washer Fluid	374

## Checking and Maintaining Wiper Blades

Lifting the Front Wiper Arms	376
Changing the Front Wiper	376
Changing the Rear Wiper Blade Rubber	377

## Checking and Maintaining Tires

Checking Tires	378
Tire Fill Assist	379
Tire and Loading Information Label	379
Tire Labeling	380
DOT Tire Quality Grading (U.S. Vehicles)	382
Wear Indicators	384
Tire Service Life	384
Tire and Wheel Replacement	384
Winter Tires	385
Tire Rotation	385

## 12-Volt Battery

Maintaining 12-Volt Battery	387
Checking the 12-Volt Battery	388
Charging the 12-Volt Battery	388

## Climate Control System Maintenance

Air Conditioning	389
------------------	-----

## Cleaning

Interior Care	390
Exterior Care	391

# Before Performing Maintenance

## Inspection and Maintenance

For your safety, perform all listed inspections and maintenance to keep your vehicle in good condition.

If you become aware of any abnormality (noise, smell, insufficient brake fluid, oil residue on the ground, etc.), have your vehicle inspected by a dealer. (Note, however, that service at a dealer is not mandatory to keep your warranties in effect.)

### Periodic inspections

- Check the brake fluid level monthly.

 Brake Fluid ▶P.374

- Check the tire pressure monthly. Examine the tread for wear and foreign objects.

 Checking Tires ▶P.378

- Check the operation of the exterior lights monthly.

 About the vehicle's LED exterior lighting ▶P.396

- Check the condition of the wiper blades at least every six months.

 Changing the Front Wiper ▶P.376

 Changing the Rear Wiper Blade Rubber ▶P.377

### Routine inspections

Perform inspections before long distance trips, when washing the vehicle, or when refueling.

### ▼ U.S. models

**Maintenance, replacement, or repair of emissions control devices and systems may be done by any automotive repair establishment or individuals using parts that are “certified” to EPA standards.**

According to state and federal regulations, failure to perform maintenance on the maintenance main items marked with # will not void your emissions warranties. However, all maintenance services should be performed in accordance with the intervals indicated by the driver information interface.

 Maintenance Service Items ▶P.362

If you want to perform complex maintenance tasks that require more skills and tools, you can purchase a subscription to the Service Express website at [www.techinfo.acura.com](http://www.techinfo.acura.com).

 If necessary ▶P.443

If you want to perform maintenance yourself, make sure that you have the necessary tools and skills first. After performing maintenance, update the records in the separate maintenance booklet.

### WARNING

Improperly maintaining this vehicle or failing to correct a problem before driving can cause a crash in which you or a passenger can be seriously hurt or killed.

Always follow the inspection and maintenance recommendations according to the schedules in this owner's manual.

### WARNING

Failure to properly follow maintenance instructions and precautions can cause you or a passenger to be seriously hurt or killed.

Always follow the procedures and precautions in this owner's manual.

## Maintenance Safety

6

Maintenance

- To reduce the possibility of fire or explosion, keep cigarettes, sparks, and flames away from the 12-volt battery and all fuel related parts.
- Never leave rags, towels, or other flammable objects under the hood.
  - » Heat from the surrounding parts can ignite them, causing a fire.
- Engine exhaust contains carbon monoxide, which is poisonous and can kill you.
  - » Only operate the engine if there is sufficient ventilation.
- To clean parts, use a commercially available degreaser or parts cleaner, not gasoline.
- Wear eye protection and protective clothing when working with the 12-volt battery or compressed air.

## Vehicle Safety

- The vehicle must be in a stationary condition.
  - » Make sure your vehicle is parked on level ground, the parking brake is set, and the engine is off.
- Make sure that the radiator fan is stopped before inspecting the engine compartment.
  - » Depending on the vehicle condition, the radiator fan may operate even when the power mode is in VEHICLE OFF.
- Be aware that hot parts can burn you.
  - » Make sure to let the engine and exhaust system cool thoroughly before touching vehicle parts.



- Be aware that moving parts can injure you.
  - » Do not start the engine unless instructed, and keep your hands and limbs away from moving parts.
  - » Do not open the hood while the Auto Idle Stop function is activated.
- The use of Acura Genuine Parts and fluids is recommended when maintaining and servicing your vehicle. Acura Genuine Parts are manufactured according to the same high quality standards used in Acura vehicles.

# Maintenance Minder™

## About Maintenance Minder™

If the engine oil life is less than 15%, you will see the Maintenance Minder messages appear on the driver information interface every time you set the power mode to ON. The messages notify you when to change the engine oil, or when to bring your vehicle to a dealer for indicated maintenance services.

## To Use Maintenance Minder™

### Displaying the Maintenance Minder Information

Maintenance items, which should be serviced at the same time that you replace the engine oil, appear on the driver information interface.

You can view them on the engine oil life screen at any time.

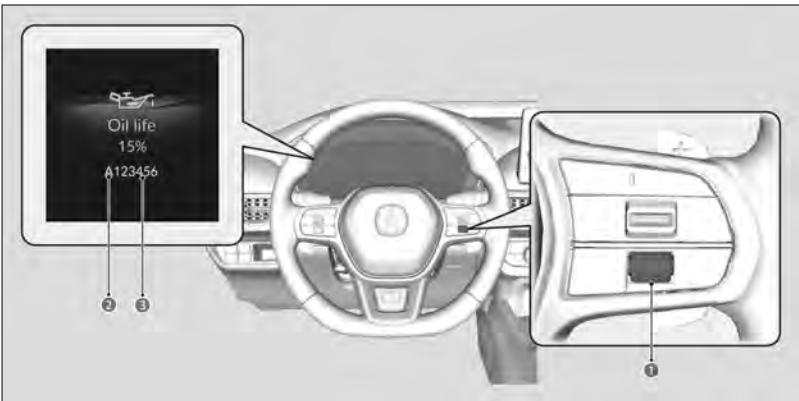

- [1] Set the power mode to ON.
- [2] Roll the right selector wheel until the Maintenance Minder screen is displayed. The engine oil life appears on the driver information interface along with maintenance items due soon.



- ① Right Selector Wheel
- ② Main Item
- ③ Sub Item

Based on the engine operating conditions, the remaining engine oil life is calculated and displayed as a percentage.

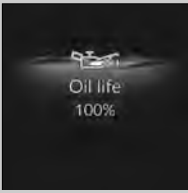
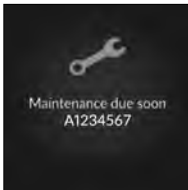
## Maintenance Minder Information on the Driver Information Interface

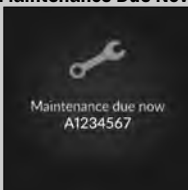
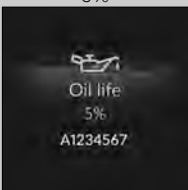
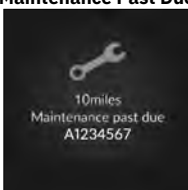
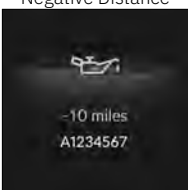
Maintenance Message	Oil Life Display	Explanation	Information
—		When you select the Maintenance Minder screen, it displays codes for maintenance items due at the next engine oil change, along with the percentage of engine oil life remaining.	—
<b>Maintenance Due Soon</b> 	15% 	The remaining engine oil life is 15 to 6 percent. Roll the right selector wheel to switch to another display.	The engine oil is approaching the end of its service life, and the maintenance items should be inspected and serviced soon.
<b>Maintenance Due Now</b> 	5% 	The remaining engine oil life is 5 to 1 percent. Roll the right selector wheel to switch to another display.	The engine oil has almost reached the end of its service life, and the maintenance items should be inspected and serviced as soon as possible.
<b>Maintenance Past Due</b> 	Negative Distance 	The remaining engine oil life has passed its service life, and a negative distance appears. Roll the right selector wheel to switch to another display.	The engine oil life has passed. The maintenance items must be inspected and serviced immediately.

The system message indicator (  ) comes on along with the Maintenance Minder message.

## Maintenance Service Items

### ▼ U.S. models

CODE	Maintenance Main Items
------	------------------------

A	<ul style="list-style-type: none"> <li>• Replace engine oil*<sup>1</sup></li> </ul>
B	<ul style="list-style-type: none"> <li>• Replace engine oil*<sup>1</sup> and oil filter</li> <li>• Inspect front and rear brakes</li> <li>• Check expiration date for tire repair kit bottle</li> <li>• Inspect these items:             <ul style="list-style-type: none"> <li>• Tie rod ends, steering gearbox, and boots</li> </ul> </li> <li>• Suspension components</li> <li>• Driveshaft boots</li> <li>• Brake hoses and lines (including ABS/VSA®)</li> <li>• All fluid levels and condition of fluids</li> <li>• Exhaust system#</li> <li>• Fuel lines and connections#</li> </ul>

CODE	Maintenance Sub Items
1	<ul style="list-style-type: none"> <li>• Rotate tires</li> </ul>
2	<ul style="list-style-type: none"> <li>• Replace air cleaner element*<sup>2</sup></li> <li>• Replace dust and pollen filter*<sup>3</sup></li> <li>• Inspect drive belt</li> </ul>
3	<ul style="list-style-type: none"> <li>• Replace transmission fluid*<sup>4</sup></li> </ul>
4	<ul style="list-style-type: none"> <li>• Replace spark plugs</li> <li>• Inspect valve clearance*<sup>5</sup></li> </ul>
5	<ul style="list-style-type: none"> <li>• Replace engine coolant</li> </ul>
6	<ul style="list-style-type: none"> <li>• Replace rear differential fluid</li> </ul>
7	<ul style="list-style-type: none"> <li>• Replace brake fluid*<sup>6</sup></li> </ul>

\*1: If a message does not appear more than 12 months after the display is reset, change the engine oil every year.

\*2: If you drive in dusty conditions, replace every 15,000 miles (24,000 km).

\*3: If you drive primarily in urban areas that have high concentrations of soot in the air from industry and from diesel powered vehicles, replace every 15,000 miles (24,000 km).

\*4: Driving in mountainous areas at very low vehicle speeds or trailer towing results in higher transmission temperatures. This requires transmission fluid changes more frequently than recommended by the Maintenance Minder. If you regularly drive your vehicle under these conditions, have the transmission fluid changed every 25,000 miles (40,000 km). (For CVT only)

\*5: Adjust the valves during services A, B, 1, 2, or 3 if they are noisy.

\*6: If a Maintenance Minder Indicator does not appear more than 36 months after the display for item 7 is reset, change the brake fluid every 3 years.

#: See information on maintenance and emissions warranty.

 About Warranty Coverages ► P.441

### ▼ Canadian models

CODE	Maintenance Main Items
A	<ul style="list-style-type: none"> <li>• Replace engine oil*1</li> </ul>
0	<ul style="list-style-type: none"> <li>• Replace engine oil*1 and oil filter</li> </ul>

CODE	Maintenance Sub Items
1	<ul style="list-style-type: none"> <li>• Rotate tires</li> </ul>
2	<ul style="list-style-type: none"> <li>• Replace air cleaner element*2</li> <li>• Replace dust and pollen filter*3</li> <li>• Inspect drive belt</li> </ul>
3	<ul style="list-style-type: none"> <li>• Replace transmission fluid*4</li> </ul>
4	<ul style="list-style-type: none"> <li>• Replace spark plugs</li> <li>• Inspect valve clearance*5</li> </ul>
5	<ul style="list-style-type: none"> <li>• Replace engine coolant</li> </ul>
6	<ul style="list-style-type: none"> <li>• Replace rear differential fluid</li> </ul>
7	<ul style="list-style-type: none"> <li>• Replace brake fluid*6</li> </ul>
9	<ul style="list-style-type: none"> <li>• Service front and rear brakes</li> <li>• Check expiration date for tire repair kit bottle</li> <li>• Inspect these items:               <ul style="list-style-type: none"> <li>• Tie rod ends, steering gearbox, and boots</li> <li>• Suspension components</li> <li>• Driveshaft boots</li> <li>• Brake hoses and lines (including ABS/VSA®)</li> <li>• All fluid levels and condition of fluids</li> <li>• Exhaust system#</li> <li>• Fuel lines and connections#</li> </ul> </li> </ul>

\*1: If a message does not appear more than 12 months after the display is reset, change the engine oil every year.

\*2: If you drive in dusty conditions, replace every 15,000 miles (24,000 km).

\*3: If you drive primarily in urban areas that have high concentrations of soot in the air from industry and from diesel powered vehicles, replace every 15,000 miles (24,000 km).

\*4: Driving in mountainous areas at very low vehicle speeds or trailer towing results in higher transmission temperatures. This requires transmission fluid changes more frequently than recommended by the Maintenance Minder. If you regularly drive your vehicle under these conditions, have the transmission fluid changed every 25,000 miles (40,000 km). (For CVT only)

\*5: Adjust the valves during services A, 0, 9, 1, 2, or 3 if they are noisy.

\*6: If a Maintenance Minder Indicator does not appear more than 36 months after the display for item 7 is reset, change the brake fluid every 3 years.

#: See information on maintenance and emissions warranty.

 [About Warranty Coverages](#) ▶ P.441

## Resetting the Display

Reset the maintenance minder information display if you have performed the maintenance service.

- [1] Set the power mode to ON.
- [2] Roll the right selector wheel until the Maintenance Minder screen is displayed.
- [3] Press and hold the right selector wheel for about 10 seconds to enter the reset mode.
- [4] Roll the right selector wheel to select a maintenance item to reset, or to select **All due items** (you can also select **Cancel** to end the process).
- [5] Press the right selector wheel to reset the selected item.
- [6] Repeat from step 3 for other items you wish to reset.



Failure to reset the Maintenance Minder™ display after a maintenance service results in the system showing incorrect maintenance intervals, which can lead to serious mechanical problems.

The dealer will reset the Maintenance Minder™ display after completing the required maintenance service. If someone other than a dealer performs maintenance service, reset the Maintenance Minder™ display yourself.

### ▼ Models with 9" Color Touchscreen with Google built-in

You can also reset the Maintenance Minder™ display using the audio/information screen.

 [How to Customize the Vehicle Settings](#) ▶ P.254

# Maintenance Under the Hood

## Maintenance Items Under the Hood

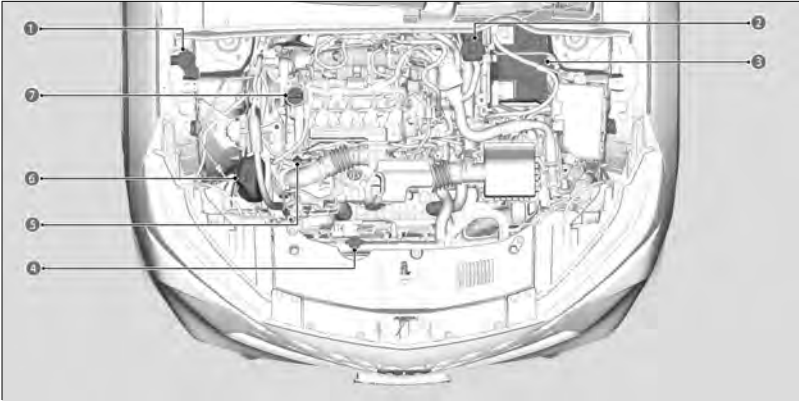

- 1 Washer Fluid (Blue Cap)
- 2 Brake Fluid (Black Cap)
- 3 12-Volt Battery
- 4 Radiator Cap
- 5 Engine Oil Dipstick (Orange)
- 6 Engine Coolant Reserve Tank
- 7 Engine Oil Fill Cap

## Opening the Hood

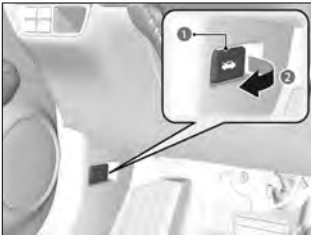

- 1 Hood Release Handle
- 2 Pull

- [1] Pull the hood release handle under the driver's side lower outside corner of the dashboard.
  - » The hood will pop up slightly.

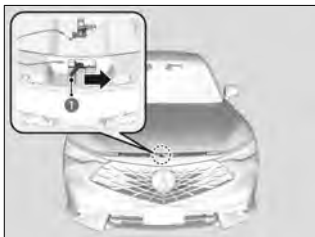

- [2] Push the hood latch lever (located under the front edge of the hood to the center) to the side and raise the hood. Once you have raised the hood slightly, you can release the lever.

### 1 Lever

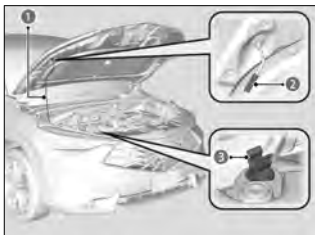

- [3] Remove the support rod from the clamp using the grip. Mount the support rod in the hood.

### 1 Support Rod

### 2 Grip

### 3 Clamp

- Park the vehicle on a level surface, and set the parking brake.
- When closing the hood, check that the hood is securely latched.
- If the hood latch lever moves stiffly, or if you can open the hood without lifting the lever, the latch mechanism should be cleaned and lubricated.

## ⚠ WARNING

The hood support rod can become very hot due to heat from the engine. To ensure against possible burns, do not handle the metal section of the rod. Use the foam grip instead.



Do not open the hood while the Auto Idle Stop function is activated.



Do not open the hood when the wiper arms are raised. The hood will strike the wipers, resulting in possible damage to the hood and/or the wipers.



## Recommended Engine Oil

Use a Genuine Acura Motor Oil or another commercial engine oil of suitable viscosity for the ambient temperature as shown.

Oil is a major contributor to your engine's performance and longevity. If you drive the vehicle with insufficient or deteriorated oil, the engine may fail or be damaged.

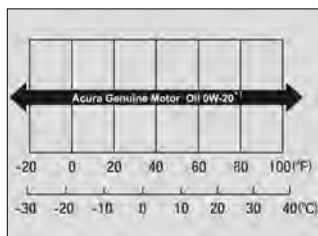

### Genuine Engine Oil

- Acura Genuine Motor Oil

\*1: Formulated to improve fuel economy.

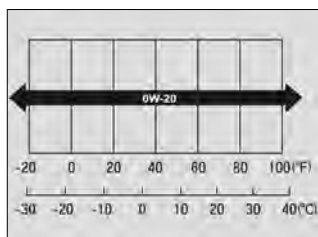

### Commercial Engine Oil

- API service SN or higher grade fuel-efficient oil
- API Certification Mark "Starburst"



The seal shown left indicates the oil is energy conserving and that it meets the American Petroleum Institute's latest requirements.

### Engine oil additives

Your vehicle does not require oil additives. In fact, they may adversely affect the engine performance and durability.

### Synthetic oil

You may also use synthetic motor oil if it is labeled with the API Certification Seal and is the specified viscosity grade.

## Oil Check

We recommend that you check the engine oil level every time you refuel.

Park the vehicle on level ground.

Wait approximately three minutes after turning the engine off before you check the oil.

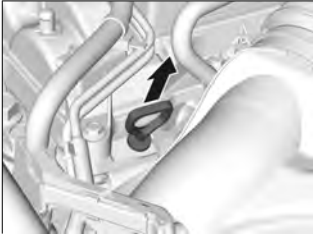

- [1] Remove the dipstick (orange).
- [2] Wipe the dipstick with a clean cloth or paper towel.
- [3] Insert the dipstick back all the way into its hole.

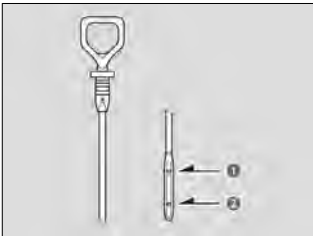

- [4] Remove the dipstick again, and check the level. It should be between the upper and lower marks. Add oil if necessary.

- ① Upper Mark
- ② Lower Mark

If the oil level is near or below the lower mark, slowly add oil, being careful not to overfill.

## Adding Engine Oil



- [1] Unscrew and remove the engine oil fill cap.
- [2] Add oil slowly.
- [3] Reinstall the engine oil fill cap, and tighten it securely.
- [4] Wait for three minutes and recheck the engine oil dipstick.

- ① Engine Oil Fill Cap

**!** Do not fill the engine oil above the upper mark. Overfilling the engine oil may result in leaks and engine damage.

If any oil spills, wipe it away immediately. Spilled oil may damage the engine compartment components.

## Changing the Engine Oil and Oil Filter

You must change the engine oil and oil filter regularly in order to maintain the engine's lubrication. The engine may be damaged if they are not changed regularly.

Change the oil and filter in accordance with the maintenance message on the driver information interface.

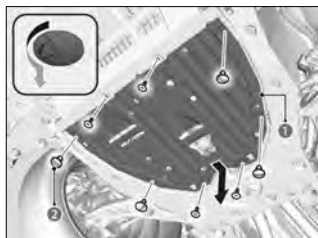

- [1] Run the engine until it reaches normal operating temperature, and then turn the engine off.
- [2] Open the hood and remove the engine oil fill cap.
- [3] Remove the Phillips-head screws and slotted head screws **(2)** by turning 90° counter-clockwise on the undercarriage and remove the under cover.

### **1** Under Cover

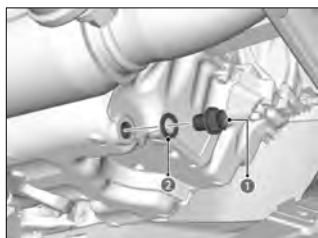

- [4] Remove the drain bolt and washer from the bottom of the engine, and drain the oil into a suitable container.

### **1** Drain Bolt

### **2** Washer

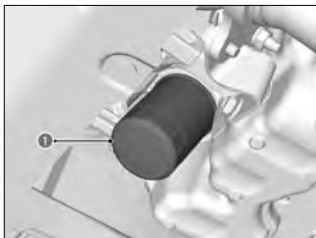

## 1 Oil Filter

- [5] Remove the oil filter and dispose of the remaining oil.
- [6] Check that the filter gasket is not stuck to the engine contact surface.
  - » If it is stuck, you must detach it.
- [7] Wipe away dirt and dust adhering to the contact surface of the engine block, and install a new oil filter.
  - » Apply a light coat of new engine oil to the filter gasket.
- [8] Put a new washer on the drain bolt, then reinstall the drain bolt.
  - » Tightening torque: 29 lbf-ft (40 N·m, 4.0 kgf·m)
- [9] Pour the recommended engine oil into the engine.
  - » Engine oil change capacity (including filter): 3.7 US qt (3.5 L)
- [10] Reinstall the engine oil fill cap securely and start the engine.
- [11] Run the engine for a few minutes, and then check that there is no leak from the drain bolt or oil filter.
- [12] Stop the engine, wait for three minutes, and then check the oil level on the dipstick.
  - » If necessary, add more engine oil.

You will need a special wrench to replace the oil filter. You can buy this wrench from a dealer.

When installing the new oil filter, follow the instructions supplied with the oil filter. Reinstall the engine oil fill cap. Start the engine. If the low oil pressure warning appears, turn off the engine, and check your work.

**!** You may damage the environment if you do not dispose of the oil in a suitable way. If you are changing the oil by yourself, appropriately dispose of the used oil. Put the oil in a sealed container and take it to a recycling center. Do not throw the oil away into a garbage can or onto the ground.

## Engine Coolant

Specified coolant: Acura Long Life Antifreeze/Coolant Type 2

This coolant is premixed with 50% antifreeze and 50% water. Do not add any straight antifreeze or water.

We recommend you check the engine coolant level every time you refuel. Check the reserve tank first. If it is completely empty, also check the coolant level in the radiator. Add the engine coolant accordingly.

If Acura antifreeze/coolant is not available, you may use another major brand of non-silicate coolant as a temporary replacement. Check that it is a high quality coolant recommended for aluminum engines. Continued use of any non-Acura coolant can result in corrosion, causing the cooling system to malfunction or fail. Have the cooling system flushed and refilled with Acura antifreeze/coolant as soon as possible.

Do not add rust inhibitors or other additives to your vehicle's cooling system. They may not be compatible with the coolant or with the engine components.

## ⚠ WARNING

Removing the radiator cap while the engine is hot can cause hot coolant to spray out, seriously scalding you.

Always let the engine and radiator cool down before removing the radiator cap.

! Genuine Acura engine coolant is a 50/50 mixture of antifreeze and water that can withstand freezing at temperatures as low as about  $-31^{\circ}\text{F}$  ( $-35^{\circ}\text{C}$ ). If your vehicle is consistently subjected to temperatures below this, the concentration of antifreeze in the coolant should be increased. Consult a dealer for details.

## Reserve Tank



- [1] **Make sure the engine and radiator are cool.**
- [2] Check the amount of coolant in the reserve tank.
  - » If the coolant level is below the **MIN** mark, add the specified coolant until it reaches the **MAX** mark.
- [3] Inspect the cooling system for leaks.

- 1 Reserve Tank
- 2 MAX
- 3 MIN

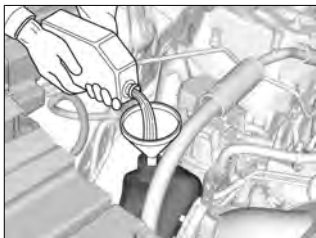

## Radiator

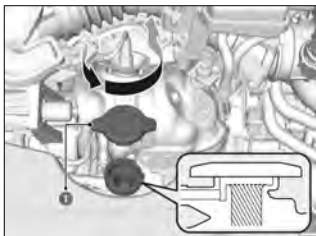

### 1 Radiator Cap

- [1] **Make sure the engine and radiator are cool.**
- [2] Turn the radiator cap 1/8th turn counterclockwise and relieve any pressure in the cooling system.
- [3] Turn the radiator cap counterclockwise to remove it.
- [4] The coolant level should be up to the base of the filler neck. Add coolant if it is low.
- [5] Put the radiator cap back on, and tighten it fully.

**!** Pour the fluid slowly and carefully so you do not spill any. Clean up any spills immediately; they can damage components in the engine compartment.

## Transmission Fluid

### Continuously Variable Transmission (CVT) Fluid

Specified fluid: Acura HCF-2

Have a dealer check the fluid level and replace if necessary.

**!** Do not mix Acura HCF-2 with other transmission fluids. Using a transmission fluid other than Acura HCF-2 may adversely affect the operation and durability of your vehicle's transmission, and damage the transmission. Any damage caused by using a transmission fluid that is not equivalent to Acura HCF-2 is not covered by Acura's new vehicle limited warranty.

## Brake Fluid

Specified fluid: Acura Heavy Duty Brake Fluid DOT 3

If the specified brake fluid is not available, you should use only DOT 3 or DOT 4 fluid from a sealed container as a temporary replacement.

Using any non-Acura brake fluid can cause corrosion and decrease the longevity of the system. Have the brake system flushed and refilled with Acura Heavy Duty Brake Fluid DOT 3 as soon as possible.

If the brake fluid level is at or below the **MIN** mark, have a dealer inspect the vehicle for leaks or worn brake pads as soon as possible.

**!** Brake fluid marked DOT 5 is not compatible with your vehicle's braking system and can cause extensive damage.

### Checking the Brake Fluid

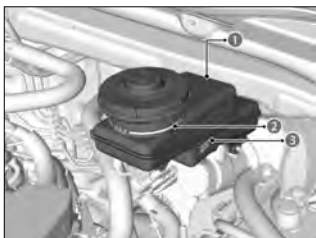

The fluid level should be between the **MIN** and **MAX** marks on the side of the reserve tank.

- ① Reserve Tank
- ② MAX
- ③ MIN

## Refilling Window Washer Fluid



If the level is low, add washer fluid.

#### ▼ Canadian models

If the washer fluid is low, a message appears on the driver information interface.

Pour the washer fluid carefully. Do not overflow the reservoir.



Do not use engine antifreeze or a vinegar/water solution in the windshield washer reservoir.

Antifreeze can damage your vehicle's paint. A vinegar/water solution can damage the windshield washer pump.

Use only commercially available windshield washer fluid.

Avoid prolonged use of hard water to prevent lime scale buildup.



# Checking and Maintaining Wiper Blades

## Lifting the Front Wiper Arms



- [1] Set the power mode to ON, then to VEHICLE OFF.
- [2] Within 10 seconds of setting the power mode to VEHICLE OFF, hold the wiper switch in the **MIST** position for more than two seconds.
  - » Both wiper arms are set to the maintenance position as shown in the image.



- [3] Lift both wiper arms.

## Changing the Front Wiper

If the wiper blade rubber has deteriorated, it will leave streaks and become noisy, and the hard surfaces of the blade may scratch the window glass.

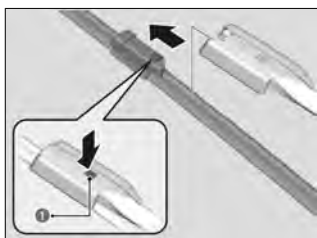

- [1] Lift both wiper arms.
- [2] Depress the lock tab, then slide the wiper blade off the wiper arm.
- [3] Slide the new wiper blade onto the wiper arm until it clicks into place.
- [4] Lower both wiper arms.
- [5] Set the power mode to ON, then set the wiper switch to the MIST position once.
  - » The wiper arms return to the standard position.

### 1 Tab

- Avoid dropping the wiper arm onto the windshield, as it may damage the wiper arm and/or the windshield.
- **When lifting the wiper arms, always follow the instructions to move them into the maintenance position.**  
The wiper arms may be damaged if they are moved manually.

## Changing the Rear Wiper Blade Rubber

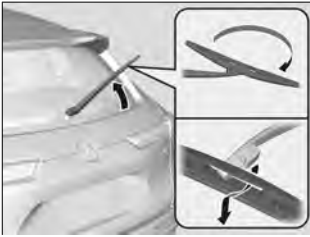

[1] Raise the wiper arm off.

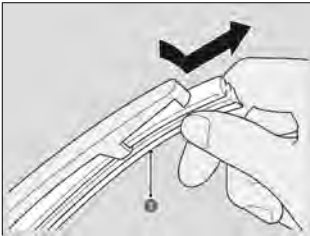

[2] Slide the wiper blade out from the end with the indent.

### 1 Blade

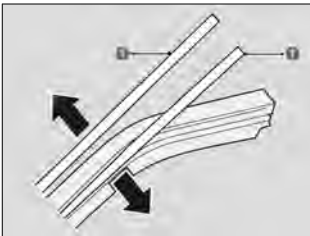

[3] Remove the retainers from wiper blade and mount to a new rubber blade.

### 1 Retainer

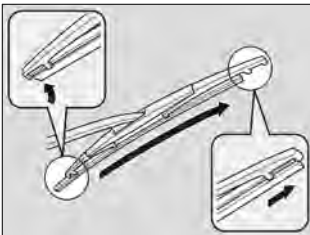

[4] Slide the new wiper blade onto the holder.  
» Make sure it is engaged correctly, then install the wiper blade assembly onto the wiper arm.

- Avoid dropping the wiper arm, as it may damage the rear window.
- Do not try to forcefully lift up the wiper arm.  
The wiper arm may be damaged if it is lifted too high.

# Checking and Maintaining Tires

## Checking Tires

Have a dealer check the tires if you feel a consistent vibration while driving. New tires and any that have been removed and reinstalled should be properly balanced.

- Measure the air pressure when tires are cold. This means the vehicle has been parked for at least three hours, or driven less than 1 mile (1.6 km). If necessary, add or release air until the specified pressure is reached.
- If checked when hot, tire pressure can be as much as 4 – 6 psi (30 – 40 kPa, 0.3 – 0.4 kgf/cm<sup>2</sup>) higher than if checked when cold.

### WARNING

Using tires that are excessively worn or improperly inflated can cause a crash in which you can be seriously hurt or killed.

Follow all instructions in this owner's manual regarding tire inflation and maintenance.

### High speed driving

We recommend that you do not drive faster than the posted speed limits and conditions allow. If you drive at sustained high speeds (over 99 mph or 160 km/h), adjust the cold tire pressures as shown below to avoid excessive heat buildup and sudden tire failure.

Tire Size	235/45R19
Pressure	Front: 36 psi (250 kPa, 2.5 kgf/cm <sup>2</sup> ) Rear: 36 psi (250 kPa, 2.5 kgf/cm <sup>2</sup> )

## Tire Requirements for Safe Driving

To safely operate your vehicle, your tires must be of the proper type and size, in good condition with adequate tread, and properly inflated.

- Tires are the correct size and type.
- The ground beneath the tires is in good condition.
- The tire pressure is correct.
- The tires do not have any wear, scratches, cracks, or foreign objects.

### Inflation guidelines

Properly inflated tires provide the best combination of handling, tread life, and comfort. Refer to the driver's doorjamb label or specifications page for the specified pressure.

Underinflated tires wear unevenly, adversely affect handling and fuel economy, and are more likely to fail from overheating.

Overinflated tires make your vehicle ride harshly, are more prone to road hazards, and wear unevenly.

Every day before you drive, look at each of the tires. If one looks lower than the others, check the pressure with a tire gauge.

At least once a month or before long trips, use a gauge to measure the pressure in all tires, including the spare\*. Even tires in good condition can lose 1 – 2 psi (10 – 20 kPa, 0.1 – 0.2 kgf/cm<sup>2</sup>) per month.

### Inspection guidelines

Every time you check inflation, also examine the tires and valve stems.

Look for:

- Bumps or bulges on the side or in the tread. Replace the tire if you find any cuts, splits, or cracks in the side of the tire. Replace it if you see fabric or cord.
- Remove any foreign objects and inspect for air leaks.
- Uneven tread wear. Have a dealer check the wheel alignment.
- Excessive tread wear.
- Cracks or other damage around valve stem.

## Tire Fill Assist

TPMS with Tire Fill Assist provides visual and audible assistance during tire pressure adjustment. With the power mode in ON and the transmission in **P**, while you adjust tire pressure up or down, the system alerts you as follows:

Below recommended pressure: The beeper sounds and exterior lights flash once every five seconds.

At recommended pressure: The beeper sounds and exterior lights flash rapidly for three seconds with five seconds intervals. Stop filling the tire.

Above recommended pressure: The beeper sounds and lights flash twice every two seconds.

When a certain amount of time has passed since activation, Tire Fill Assist will be canceled until you set the power mode to OFF.

You cannot use Tire Fill Assist if the engine was started by the remote engine start, or if there is a malfunction in the system. If Tire Fill Assist does not work, use a tire pressure gauge.

## Tire and Loading Information Label

The label attached to the driver's doorjamb provides necessary tire and loading information.

\*: Not available on all models

## Label Example

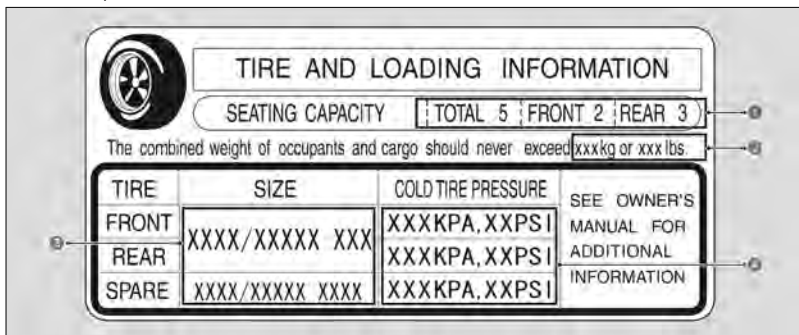

The tire and loading information label attached to the driver's doorjamb contains:

- 1 The number of people your vehicle can carry.
- 2 The total weight your vehicle can carry. Do not exceed this weight.
- 3 The original tire sizes for front, rear, and spare.
- 4 The proper cold tire pressure for front, rear, and spare.

## Tire Labeling

### Example

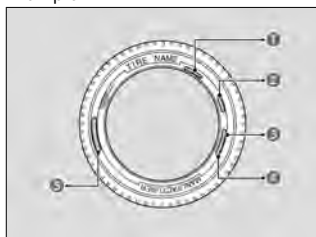

- 1 Tire Size
- 2 Tire Identification Number (TIN)
- 3 Maximum Tire Load
- 4 Maximum Tire Pressure
- 5 Tire Size

The tires that came on your vehicle have a number of markings. Those you should be aware of are described as shown.

## Tire Sizes

Whenever tires are replaced, they should be replaced with tires of the same size. Following is an example of tire size with an explanation of what each component means.

### **P235/60 R18 102T**

P: Vehicle type (P indicates passenger vehicle).

235: Tire width in millimeters.

60: Aspect ratio (the tire's section height as a percentage of its width).

R: Tire construction code (R indicates radial).

18: Rim diameter in inches.

102: Load index (a numerical code associated with the maximum load the tire can carry).

T: Speed symbol (an alphabetical code indicating the maximum speed rating).

## Tire Identification Number (TIN)

The tire identification number (TIN) is a group of numbers and letters that look like the examples in the side column. TIN is located on the sidewall of the tire.

There are two different formats that TIN may be listed in.

### ▼ Format A

#### **DOT B97R FW6X 2209**

DOT: This indicates that the tire meets all requirements of the U.S. Department of Transportation.

B97R: Manufacturer's identification mark.

FW6X: Tire type code.

2209: Date of manufacture (22: Week, 09: Year).

### ▼ Format B

#### **DOT 1A3 OFBEKP 1522**

DOT: This indicates that the tire meets all requirements of the U.S. Department of Transportation.

1A3: PLANT CODE

OFBEKP: MANUFACTURE CODE

1522: DATE CODE (15: Week, 22: Year)

## Glossary of Tire Terminology

**Cold Tire Pressure**— The tire air pressure when the vehicle has been parked for at least three hours or driven less than 1 mile (1.6 km).

**Load Rating**— Means the maximum load that a tire is rated to carry for a given inflation pressure.

**Maximum Inflation Pressure**— The maximum tire air pressure that the tire can hold.

**Maximum Load Rating**– Means the load rating for a tire at the maximum permissible inflation pressure for that tire.

**Recommended Inflation Pressure**– The cold tire inflation pressure recommended by the manufacturer.

**Treadwear Indicators (TWI)**– Means the projections within the principal grooves designed to give a visual indication of the degrees of wear of the tread.

## DOT Tire Quality Grading (U.S. Vehicles)

The tires on your vehicle meet all U.S. Federal Safety Requirements. All tires are also graded for treadwear, traction, and temperature performance according to Department of Transportation (DOT) standards. The following explains these gradings.

### Uniform Tire Quality Grading

Quality grades can be found where applicable on the tire sidewall between tread shoulder and maximum section width. For example:

**Treadwear 200**

**Traction AA**

**Temperature A**

All passenger car tires must conform to Federal Safety Requirements in addition to these grades.

### Treadwear

The treadwear grade is a comparative rating based on the wear rate of the tire when tested under controlled conditions on a specified government test course. For example, a tire graded 150 would wear one and one-half (1 1/2) times as well on the government course as a tire graded 100. The relative performance of tires depends upon the actual conditions of their use, however, and may depart significantly from the norm due to variations in driving habits, service practices and differences in road characteristics and climate.

## Traction

The traction grades, from highest to lowest, are AA, A, B, and C. Those grades represent the tire's ability to stop on wet pavement as measured under controlled conditions on specified government test surfaces of asphalt and concrete. A tire marked C may have poor traction performance.

Warning: The traction grade assigned to this tire is based on straight-ahead braking traction tests, and does not include acceleration, cornering, hydroplaning, or peak traction characteristics.

## Temperature

The temperature grades are A (the highest), B, and C, representing the tire's resistance to the generation of heat and its ability to dissipate heat when tested under controlled conditions on a specified indoor laboratory test wheel. Sustained high temperature can cause the material of the tire to degenerate and reduce tire life, and excessive temperature can lead to sudden tire failure. The grade C corresponds to a level of performance which all passenger car tires must meet under the Federal Motor Vehicle Safety Standard No. 109. Grades B and A represent higher levels of performance on the laboratory test wheel than the minimum required by law.

Warning: The temperature grade for this tire is established for a tire that is properly inflated and not overloaded. Excessive speed, underinflation, or excessive loading, either separately or in combination, can cause heat buildup and possible tire failure.



## Wear Indicators

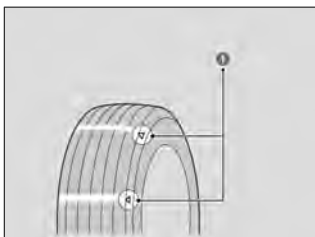

The groove where the wear indicator is located is about 1/16 inch (about 1.6 mm) shallower than elsewhere on the tire. If the tread has worn so that the indicator is exposed, replace the tire.

**Worn out tires have poor traction on wet roads.**

### 1 Wear Indicator

## Tire Service Life

The life of your tires is dependent on many factors, including driving habits, road conditions, vehicle loading, inflation pressure, maintenance history, speed, and environmental conditions (even when the tires are not in use).

In addition to regular inspections and inflation pressure maintenance, it is recommended that you have annual inspections performed once the tires reach five years old. All tires, including the spare\*, should be removed from service after 10 years from the date of manufacture, regardless of their condition or state of wear.

## Tire and Wheel Replacement

Replace your tires with radials of the same size, load range, speed rating, and maximum cold tire pressure rating (as shown on the tire's sidewall). Using tires of a different size or construction can cause certain vehicle systems such as the ABS and Vehicle Stability Assist™ (VSA™) system to work incorrectly.

It is best to replace all four tires at the same time. If that isn't possible, replace the front or rear tires in pairs.

Whenever you have a tire replaced or reset, make sure that the rubber valve stem is replaced and that the TPMS sensor is transferred from the old valve stem to the new one.

If you replace a wheel, make sure that the wheel's specifications match those of the original wheels.

### **⚠ WARNING**

Installing improper tires on your vehicle can affect handling and stability. This can cause a crash in which you can be seriously hurt or killed. Always use the size and type of tires recommended in this owner's manual.

\*: Not available on all models

## Winter Tires

If driving on snowy or frozen roads, mount all season marked **M+S** tires, or snow tires; reduce speed; and maintain sufficient distance between vehicles when driving. Be particularly careful when operating the steering wheel or brakes to prevent skidding.

Use snow tires, or all season tires when necessary or according to the law.

You cannot use tire chains.

Attempting to use them may damage the body, suspension, and brake lines, etc.

## Tire Rotation

Rotating tires according to the maintenance schedule helps to distribute wear more evenly and increase tire life.

### Tires without rotation marks

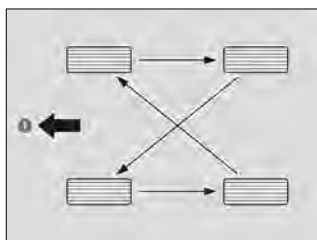

1 Front

### Tires with rotation marks

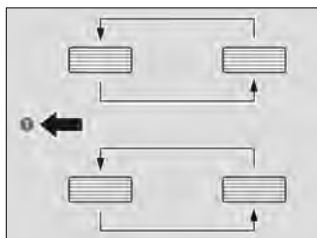

1 Front

Wheel nut torque for the tires that come standard-equipped with your vehicle is as follows.

#### Wheel nut torque:

80 lbf·ft (108 N·m, 11 kgf·m)

Whenever tires are rotated, you must calibrate the TPMS.

# 12-Volt Battery

## Maintaining 12-Volt Battery

When you find corrosion, clean the 12-volt battery terminals by applying a baking powder and water solution.

Clean the terminals with a damp towel. Cloth/towel dry the 12-volt battery. Coat the terminals with grease to help prevent future corrosion.

When replacing the 12-volt battery, the replacement must be of the same specifications.

Consult a dealer for more information.

### WARNING

The 12-volt battery gives off explosive hydrogen gas during normal operation.

A spark or flame can cause the 12-volt battery to explode with enough force to kill or seriously hurt you.

When conducting any 12-volt battery maintenance, wear protective clothing and a face shield, or have a skilled technician do it.

**WARNING:** Battery post, terminals, and related accessories contain lead and lead compounds.

### **Wash your hands after handling.**

The 12-volt battery installed in this vehicle is specifically designed for a model with Auto Idle Stop or System Updates\*.

Using a 12-volt battery other than this specified type may shorten the battery life, and prevent Auto Idle Stop or System Updates\* from activating. If you need to replace the battery, make sure to select the specified type and size. Ask a dealer for more details.

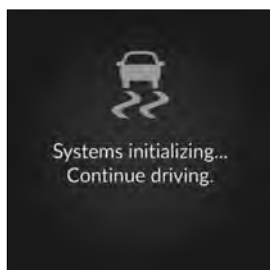

After re-connecting the 12-volt battery: if various indicators come on and the message on the left is displayed on the driver information interface, drive a short distance at a speed of 12 mph (20 km/h) or higher. If the indicator does not go off, have your vehicle checked by a dealer.

\*: Not available on all models

## Checking the 12-Volt Battery

The condition of the 12-volt battery is monitored by a sensor located on the negative terminal of the 12-volt battery. If there is a problem with this sensor, the driver information interface will display a warning message. If this happens, have your vehicle inspected by a dealer.

Check the 12-volt battery terminals for corrosion monthly.

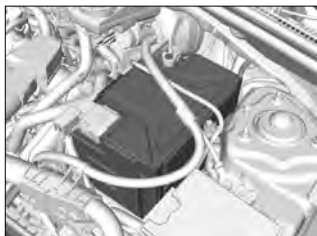

If your vehicle's 12-volt battery is disconnected or goes dead:

- The audio system is disabled.
- The clock resets.
- The immobilizer system needs to be reset.

**Q** Immobilizer System Indicator ▶ P.335

## Charging the 12-Volt Battery

Disconnect both 12-volt battery cables to prevent damaging your vehicle's electrical system.

Always disconnect the negative (-) cable first, and reconnect it last.

### ▼ Models with System Updates

If the battery cable is removed while a system update is being performed, the electrical system can be permanently damaged. Only remove the battery cable when a system update is not being performed.

# Climate Control System Maintenance

## Air Conditioning

To ensure proper and safe operation, the Society of Automotive Engineers (SAE J2845) recommends that the refrigerant system only be serviced by trained and certified technicians.

Never repair or replace the air conditioning evaporator (cooling coil) with one removed from a used or salvaged vehicle.

New replacement mobile air conditioning evaporators must be certified (and labeled) as meeting SAE Standard J2842.

Refrigerant in your vehicle's air conditioning system is flammable and can be ignited during servicing if proper procedures are not followed.

The air conditioner label is found under the hood:

 Label Locations ▶ P.47

 About Specifications ▶ P.434

### ▼ Canadian models



- 1 Caution
- 2 Flammable Refrigerant
- 3 Requires Registered Technician to Service
- 4 Air Conditioning System



Vented refrigerant is harmful to the environment.

To avoid refrigerant from venting, never replace the evaporator with one removed from a used or salvaged vehicle.

The climate control system is equipped with a dust and pollen filter that collects pollen, dust, and other debris in the air. The Maintenance Minder™ messages will let you know when to replace the filter.

We recommend that you replace the dust and pollen filter sooner when using your vehicle in areas with high concentrations of dust.

# Cleaning

## Interior Care

Use a damp cloth with a mixture of mild detergent and warm water to remove dirt. Use a clean cloth to remove detergent residue.

**!** Do not spill liquids inside the vehicle. Electrical devices and systems may malfunction if liquids are splashed on them.

**!** Do not use silicone-based sprays on electrical devices such as audio devices and switches. Doing so may cause the items to malfunction or cause a fire inside the vehicle. If a silicone-based spray is inadvertently used on electrical devices, consult a dealer.

**!** Depending on their composition, chemicals and liquid aromatics may cause discoloration, wrinkles, and cracking to resin-based parts and textiles. Do not use alkali solvents or organic solvents such as benzene or gasoline.

**!** After using chemicals, make sure to gently wipe them away using a dry cloth. Do not place used cloths on top of resin-based parts or textiles for long periods of time without washing.

### Cleaning seat belts

Use a soft brush with a mixture of mild soap and warm water to clean the seat belts. Let the belts air dry. Wipe the openings of the seat belt anchors using a clean cloth.

### Cleaning the window

Wipe using a glass cleaner.

❗ Wires are mounted to the inside of the rear window. Wipe along the same direction as the wires with a soft cloth so as not to damage them.

❗ Be careful not to spill fluids, such as water or glass cleaner, on or around the cover of the electrical components around the rearview mirror.

## Floor mats

### Example

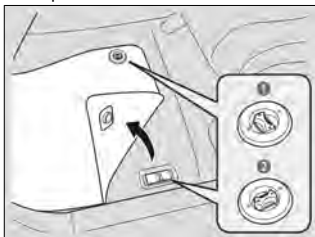

The driver's floor mat hooks over floor anchors, which keep the mat from sliding forward.

**Do not put any additional floor mats on top of the anchored mat.**

- 1 Unlock
- 2 Lock

If you use any floor mats that were not originally provided with your vehicle, make sure they are designed for your specific vehicle, fit correctly, and are securely anchored by the floor anchors.

Position any rear seat floor mats properly. If not properly positioned, the floor mats can interfere with the front seat functions.

## Exterior Care

Dust off the vehicle body after you drive. Regularly inspect your vehicle for scratches on painted surfaces. A scratch on a painted surface can result in body rust. If you find a scratch, promptly repair it.

## Washing the vehicle

Wash the vehicle regularly. Wash more frequently when driving in the following conditions:

- If driving on roads with road salt.
- If driving in coastal areas.
- If tar, soot, bird droppings, insects, or tree sap is stuck to painted surfaces.



Do not spray water into the air intake vents. It can cause a malfunction.

If water and any chemicals are on the brakes when your vehicle is being washed, drive a short distance and apply the brakes several times before parking. Parking while brakes are wet may cause them to be stuck by rust.

- Lock the doors when washing the vehicle. Do not spray water onto the fuel fill door directly. A high-pressure spray may cause it to open.

Do not spray water onto the capless unit when the fuel fill door is open. It can cause damage to the fuel system or engine.

- If you need to lift the wiper arms away from the windshield, first set the wiper arms to the maintenance position.

 [Lifting the Front Wiper Arms](#) ▶ P.376

## ■ Using high pressure cleaners

- Keep sufficient distance between the cleaning nozzle and the vehicle body.
- Take particular care around the windows. Standing too close may cause water to enter the vehicle interior.
- Do not spray high pressure water directly into the engine compartment. Instead, use low pressure water and a mild detergent.
- Do not spray water directly onto the camera or the area around it. Water may enter the lens and cause the camera to malfunction.
- Chemical solvents and strong cleaners can damage the paint, metal, and plastic on your vehicle. Wipe away spills immediately.

## ■ Maintaining the bumpers and other resin-coated parts

If you get gasoline, oil, engine coolant, or 12-volt battery fluid on resin-coated parts, they may stain or the coating may peel. Promptly wipe it away using a soft cloth and clean water.

- Ask a dealer about the correct coating material when you want to repair the painted surface of the parts made of resin.

## ■ Cleaning the window

Wipe using a glass cleaner.

## ■ Maintaining aluminum wheels

Aluminum is susceptible to deterioration caused by salt and other road contaminants. When necessary, as early as possible use a sponge and mild detergent to wipe away these contaminants. Do not use a stiff brush or harsh chemicals (including some commercial wheel cleaners). These can damage the protective finish on aluminum alloy wheels, resulting in corrosion. Depending on the type of finish, the wheels also may lose their luster or appear burnished. To avoid water stains, wipe the wheels dry with a cloth while they are still wet.

# Handling the Unexpected

## Tools

Types of Tools..... 394

## When a Lightbulb Goes Out

About the Vehicle's LED Exterior Lighting..... 396

## Remote Transmitter Care

Replacing the Remote Battery..... 397

## If a Tire Goes Flat

Temporarily Repairing a Flat Tire..... 399

Injecting Sealant and Air..... 401

Inflating an Under-inflated Tire..... 405

Changing a Flat Tire..... 407

## Engine Does Not Start

Checking the Engine..... 412

If the Keyless Remote Battery is Weak..... 413

Emergency Engine Stop..... 413

Emergency Engine Start..... 413

## If the 12-volt Battery Is Dead

Jump Starting Procedure..... 415

What to Do After the Engine Starts..... 416

## Shift Lever Does Not Move

Releasing the Lock..... 417

## Overheating

How to Handle Overheating..... 418

## When a Warning Appears

If the **Engine oil pressure low** Warning Appears..... 420

## Fuses

Checking Fuses..... 421

Interior Fuse Box..... 423

Interior Sub Fuse Box..... 424

Inspecting and Changing Fuses..... 425

## Emergency Towing

About Towing..... 427

## If You Cannot Unlock the Fuel Fill Door

What to Do If Unable to Unlock the Fuel Fill Door..... 428

## If You Cannot Open the Tailgate

What to Do If Unable to Open the Tailgate..... 429

## Refueling

Refueling From a Portable Fuel Container..... 430

## Emergency Call (eCall)\*

Automatic Emergency Call..... 431

Manual Emergency Call..... 432

\*: Not available on all models

# Tools

## Types of Tools

### ▼ Models with temporary tire repair kit



- 1 Tool Case
- 2 Funnel

### ▼ Models with spare tire

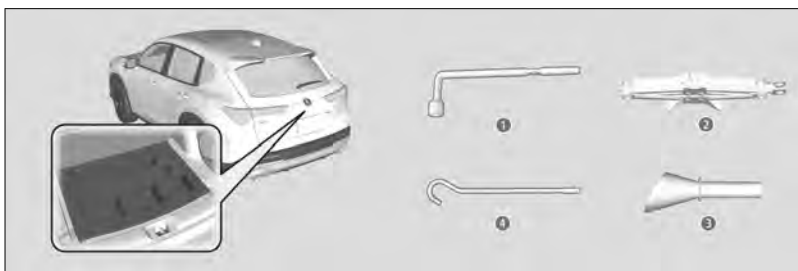

- 1 Wheel Nut Wrench/Jack Handle
- 2 Jack
- 3 Funnel
- 4 Jack Handle Bar

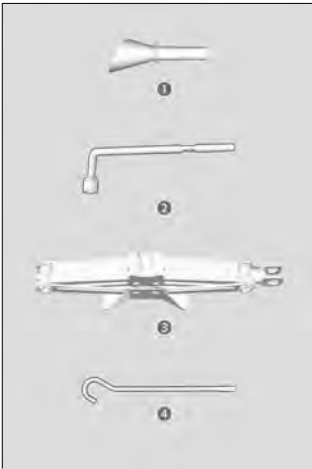

▼ All models

- 1 Funnel

▼ Models with spare tire

- 2 Wheel Nut Wrench/Jack Handle
- 3 Jack
- 4 Jack Handle Bar

The tools are stored in the cargo area.

# When a Lightbulb Goes Out

## About the Vehicle's LED Exterior Lighting

The following lights are LED lights. Have an authorized Acura dealer inspect and replace them.

- Headlights
- Front Turn Signal Lights
- Parking/Chicane™ Daytime Running Lights
- Front Side Marker Lights
- Fog Lights\*
- Side Turn Signal/Emergency Indicator Lights (on Door Mirrors)
- Brake Lights
- Chicane™ Taillights
- High-Mount Brake Light
- Rear Turn Signal Lights
- Rear Side Marker/Chicane™ Taillights
- Back-Up Lights
- Rear License Plate Light

The headlight aim is set by the factory, and does not need to be adjusted. However, if you regularly carry heavy items in the cargo area, have the aiming readjusted at a dealer or by a qualified technician.

\*: Not available on all models

# Remote Transmitter Care

## Replacing the Remote Battery

If the indicator does not come on when the button is pressed, replace the battery.

### **⚠ WARNING**

#### **CHEMICAL BURN HAZARD**

The battery that powers the remote transmitter can cause severe internal burns and can even lead to death if swallowed.

Keep new and used batteries away from children.

If you suspect that a child has swallowed the battery, seek medical attention immediately.



An improperly disposed of battery can damage the environment. Always confirm local regulations for battery disposal.

Replacement batteries are commercially available or at a dealer.

## Keyless Remote

### ▼ Models without two-way keyless remote

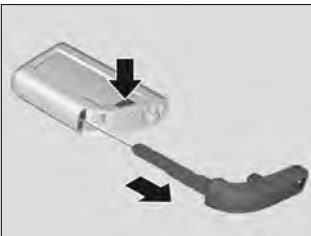

[1] Remove the built-in key.

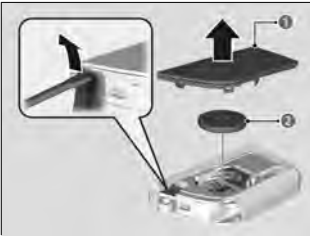

- [2] Pry on the edge of the cover using a flat-tip screwdriver to remove the cover.
- [3] Make sure to replace the battery with the correct polarity.

- 1 Cover
- 2 Battery

#### ▼ Models with two-way keyless remote

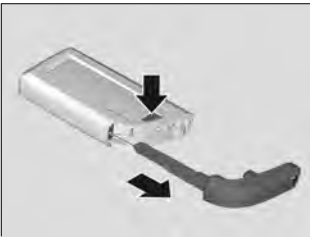

- [1] Remove the built-in key.

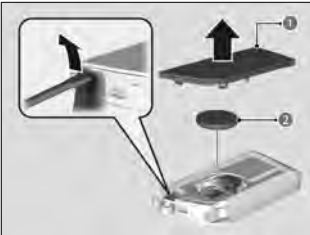

- [2] Pry on the edge of the cover using a flat-tip screwdriver to remove the cover.
- [3] Make sure to replace the battery with the correct polarity.

- 1 Cover
- 2 Battery

Battery type: CR2032

- Wrap a flat-tip screwdriver with a cloth to prevent scratching the keyless remote

# If a Tire Goes Flat

## ▼ Models with temporary tire repair kit

### Temporarily Repairing a Flat Tire

If the tire has a large cut or is otherwise severely damaged, you will need to have the vehicle towed. If the tire only has a small puncture, from a nail for instance, you can use the temporary tire repair kit so that you can drive to the nearest service station for a more permanent repair.

#### ■ How to park your vehicle

If a tire goes flat while driving, grasp the steering wheel firmly, and brake gradually to reduce speed. Then, stop in a safe place.

- [1] Park the vehicle on a firm, level, non-slippery surface and apply the parking brake.
- [2] Put the transmission into **P**.
- [3] Turn on the hazard warning lights and set the power mode to OFF.

**!** The kit should not be used in the following situations. Instead, contact a dealer or roadside assistance to have the vehicle towed.

- The tire sealant has expired.
- More than one tire is punctured.
- The puncture or cut is larger than 3/16 inch (4 mm).
- The tire side wall is damaged or the puncture is outside the tire area.
- Damage has been caused by driving with the tire extremely under inflated.
- The tire bead is no longer seated.
- The rim is damaged.

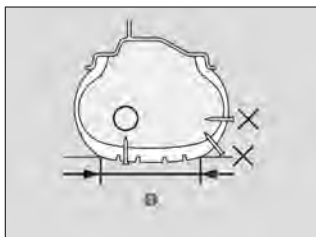

**1** Contact Area



**!** Do not remove a nail or screw that punctured the tire.  
If you remove it from the tire, you may not be able to repair the puncture using the kit.

**!** Do not continue driving with the temporarily repaired tire.  
Do not use the temporary repairs for any purpose other than moving your vehicle to the nearest service station to receive professional repairs.

**!** Do not use a puncture-repairing agent other than the one provided in the kit that came with your vehicle.  
If a different agent is used, you may permanently damage the tire pressure sensor.

## Getting Ready to Temporarily Repair the Flat Tire

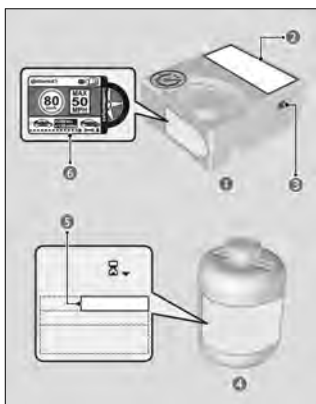

- 1 Air Compressor
- 2 Instruction Label
- 3 Air Compressor Switch
- 4 Sealant Bottle
- 5 Expiration Date
- 6 Speed Restriction Label

- Speed restriction label is applied to the side of the temporary tire repair kit.
- When making a temporary repair, carefully read the instruction manual provided with the kit.

**!** When using the compressor, please note the following points.

- Avoid getting water on it during rain.
- Do not place the product directly on a sandy or dusty area before using it, as inhaling dust may cause a malfunction.
- Do not lubricate with oil or lubricant.
- Never disassemble or modify the product.
- Do not subject the compressor to any impacts. This may cause a malfunction.

## Taking out the Tire Repair Kit



- [1] Open the lid.
- [2] Take the kit out of the case.
- [3] Place the kit (1) face up on flat ground near the flat tire and away from traffic. Do not place the kit on its side.



## Injecting Sealant and Air



- [1] Take the air compressor hose (2) and plug cord (1) out of the back of the air compressor.



- [2] Remove the cap from the air compressor.



[3] Shake the bottle well.



[4] Remove the bottle cap (1).  
» Do not remove the sealed cover (2).



[5] Screw the sealed bottle onto the air compressor.  
» Screw the bottle tightly so that it does not become loose.

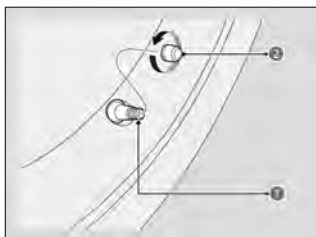

[6] Unscrew the valve cap.

- 1 Valve
- 2 Valve Cap

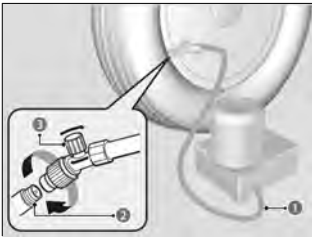

- [7] Screw the air compressor hose (1) onto the tire valve (2).
- » Make sure the air valve (3) is closed and the air compressor is turned off.

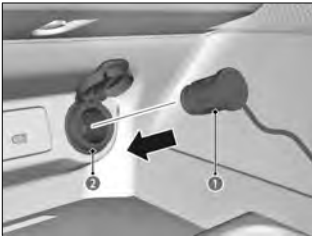

- [8] Plug (1) in the compressor to the accessory power socket (2).

» Be careful not to pinch the cord in a door or window.

**Q Accessory Power Sockets ▶ P.169**

» Do not plug any other electric devices into other accessory power sockets.

- [9] Start the engine.

» Keep the engine running while injecting air.

**Q Carbon Monoxide Gas ▶ P.31**

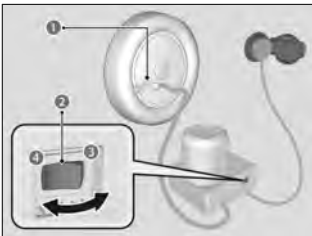

- [10] Turn the air compressor on and inflate the tire to the specified air pressure.
- » The compressor starts injecting sealant and air into the tire.
  - » Refer to the driver's doorjamb label for the specified pressure.

- [11] After the air pressure reaches the specified pressure, turn off the compressor.

» Check the air pressure gauge on the air compressor.

» If overinflated, release the air by turning the air valve (1). Be careful not to spill any sealant.

- [12] Unplug the plug from the accessory power socket.

- [13] Unscrew the air compressor hose from the tire valve. Install the hose cap.

» Be careful not to spill any sealant when the hose is disconnected. Wipe away any spills.

- [14] Store the tire repair kit in the cargo area.

» Do not remove the sealant bottle from the air compressor.

- 2 Switch
- 3 ON
- 4 OFF

- Keep the engine on while injecting sealant and air.
- Until the sealant injection is complete, the pressure shown on the pressure gauge will appear higher than actual. After the sealant injection is complete the pressure will drop and then begin to rise again as the tire is inflated with air. This is normal.

- To accurately measure the air pressure using the gauge, turn the air compressor off only after the sealant injection is complete.
- If the required air pressure is not reached within 10 minutes, the tire may be too severely damaged for the kit to provide the necessary seal and your vehicle will need to be towed.
- See an Acura dealer for a replacement sealant bottle and proper disposal of an empty bottle.
- Turn the air compressor off when connecting the compressor hose.
- You hear a motor sound coming from the activated air compressor.
- Inform the use of tire sealant when you ask an Acura dealer or the road assistant service for replacing or repairing the flat tire.
- Store the empty bottle in its original position.



Do not operate the temporary tire repair kit compressor for more than 15 minutes.

The compressor can overheat and become permanently damaged.



Keep the sealant bottle out of the reach of children.



In cold temperatures, the sealant may not flow easily.

In this situation, warm it by keeping the bottle in the passenger compartment before using.



The sealant is latex based and can permanently stain clothing and other materials. Be careful during handling and wipe up any spills immediately.

## WARNING

Tire sealant contains substances that are harmful and can be fatal if swallowed.

If accidentally swallowed, do not induce vomiting. Drink plenty of water and get medical attention immediately.

For skin or eye contact, flush with cool water and get medical attention if necessary.

## WARNING

Running the engine with the vehicle in an enclosed or even partly enclosed area can cause a rapid buildup of toxic carbon monoxide.

Breathing this colorless, odorless gas can cause unconsciousness and even death.

Only run the engine to power the air compressor with the vehicle outdoors.

## Distributing the Sealant in the Tire



- [1] Apply the speed restriction label to the location as shown.
- [2] Drive the vehicle for about 10 minutes or 1 to 6 miles (3 to 10 kilometers).
  - » Do not exceed 50 mph (80 km/h).
- [3] Stop the vehicle in a safe place.



- 1 Air Compressor
- 2 ON
- 3 OFF

- [4] Recheck the air pressure using the gauge on the air compressor.
  - » Do not turn the air compressor on to check the pressure.
- [5] If the air pressure is

**Q Inflating an Under-inflated Tire ▶P.405**

- Less than 19 psi (130 kPa):  
Do not add air or continue driving. The leak is too severe. Call for help and have your vehicle towed.
- Specified air pressure (see the label on driver's doorjamb) or more:  
Continue driving until you reach the nearest service station. Do not exceed 50 mph (80 km/h).
- Greater than 19 psi (130 kPa), but less than specified air pressure (see the label on driver's doorjamb):  
Inflate the tire to the specified air pressure.

**Q Inflating an Under-inflated Tire ▶P.405**

And repeat steps 2 to 4 until you reach the nearest service station. Do not exceed 50 mph (80 km/h).

- » The distance to the nearest service station has to be within about 124 miles (200 kilometers).

- [6] Repackage and properly stow the kit.

**!** Refer to the driver's doorjamb label for the specified pressure.

## Inflating an Under-inflated Tire

You can use the kit to inflate a non-punctured under-inflated tire.

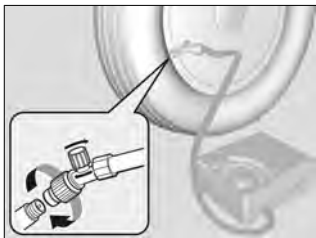

- [1] Take the air compressor out of the cargo area.
- [2] Place the kit face up on flat ground near the tire to be inflated, away from traffic. Do not place the kit on its side.
- [3] Remove the valve cap.
- [4] Attach the hose onto the tire valve. Screw it until it is tight.
  - » Make sure the air valve is closed.

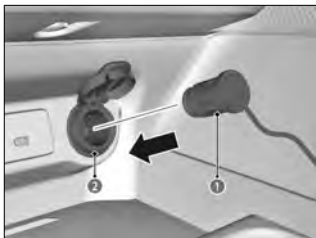

- [5] Plug **(1)** in the compressor to the accessory power socket **(2)**.
  - » Be careful not to pinch the cord in a door or window.

[Q Accessory Power Sockets](#) ▶ P.169

- » Do not plug any other electric devices into other accessory power sockets.

- [6] Start the engine.
  - » Keep the engine running while injecting air.

[Q Carbon Monoxide Gas](#) ▶ P.31

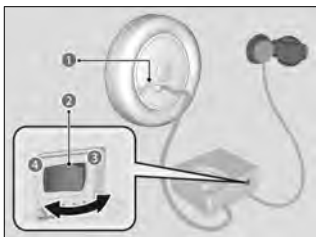

- 1** Air Valve
- 2** Switch
- 3** ON
- 4** OFF

- [7] Turn on the air compressor switch to inflate the tire.
  - » The compressor starts to inject air into the tire.
  - » If you have started the engine, leave it running while injecting air.
- [8] Inflate the tire to the specified air pressure.
- [9] Turn off the air compressor.
  - » Check the pressure gauge on the air compressor.
  - » If overinflated, turn the air valve to deflate.
- [10] Turn off the engine, then unplug the air compressor from the accessory power socket.
- [11] Unscrew the air compressor hose from the tire valve. Reinstall the valve cap.
- [12] Store the air compressor in the cargo area.

- Keep the engine on while injecting sealant and air.
- Do not operate the temporary tire repair kit compressor for more than 15 minutes. The compressor can overheat and become permanently damaged.

**⚠ WARNING**

Running the engine with the vehicle in an enclosed or even partly enclosed area can cause a rapid buildup of toxic carbon monoxide.

Breathing this colorless, odorless gas can cause unconsciousness and even death.

Only run the engine to power the air compressor with the vehicle outdoors.

**▼ Models with spare tire****Changing a Flat Tire**

If a tire goes flat while driving, grasp the steering wheel firmly and brake gradually to reduce speed. Then, stop in a safe place. Replace the flat tire with a spare tire. Go to a dealer as soon as possible to have the regular tire repaired or replaced.

- [1] Park the vehicle on a firm, level, non-slippery surface and apply the parking brake.
- [2] Put the transmission into **P**.
- [3] Turn on the hazard warning lights and turn off the engine.

Follow compact spare precautions:

Periodically check the tire pressure of the compact spare. It should be set to the specified pressure.

Specified Pressure: 60 psi (420 kPa, 4.2 kgf/cm<sup>2</sup>)

When driving with the compact spare tire, keep the vehicle speed under 50 mph (80 km/h). Replace with a full-size tire as soon as possible.

The compact spare tire and wheel in your vehicle are specifically for this model. Do not use them with another vehicle. Do not use another type of compact spare tire or wheel with your vehicle.

Do not mount tire chains on a compact spare tire.

If a chain-mounted front tire goes flat, remove one of the full-size rear tires and replace it with the compact spare tire. Remove the flat front tire and replace it with the full-size tire that was removed from the rear.

Mount the tire chains on the front tire.



Do not use the jack if it doesn't work properly.  
Call your dealer or a professional towing service.



## Getting Ready to Replace the Flat Tire



- [1] Open the lid.
- [2] Take the jack, wheel nut wrench, and jack handle bar out of the tool case; unscrew the wing bolt and remove the spacer cone, then remove the spare tire.

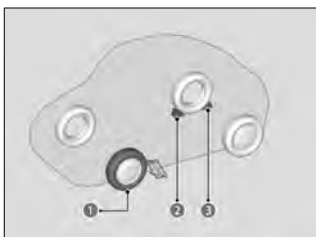

- [3] Place a wheel block or rock in front (2) and rear (3) of the wheel diagonal to the flat tire (1).



- [4] Place the compact spare tire (wheel side up) under the vehicle body, near the tire that needs to be replaced.



- [5] Loosen each wheel nut about one turn using the wheel nut wrench.

## How to Set Up the Jack

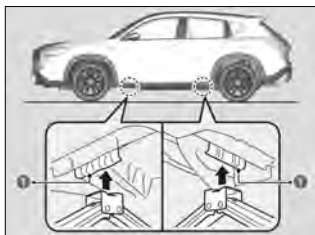

- [1] Place the jack under the jacking point (1) closest to the tire to be changed.

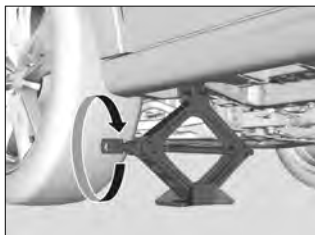

- [2] Turn the end bracket clockwise as shown in the image until the top of the jack contacts the jacking point.  
 » Make sure that the jacking point tab is resting in the jack notch.

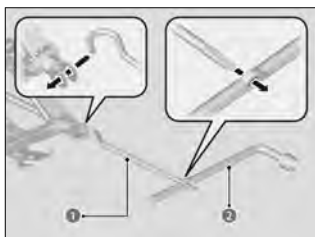

- [3] Raise the vehicle using the jack handle bar (1) and the jack handle (2) until the tire is off the ground.

### **⚠ WARNING**

The vehicle can easily roll off the jack, seriously injuring anyone underneath.

Follow the directions for changing a tire exactly, and no person should place any portion of their body under a vehicle that is supported by a jack.



Use the jack provided in your vehicle.

Other jacks may not support the weight ("load") or may not fit the jacking point.

**⚠ CAUTION**

The following instructions must be followed to use the jack safely:

- Do not use while the engine is running.
- Do not use with people or cargo in the vehicle.
- Use only where the ground is firm and level.
- Use only at the jacking points.
- Do not get in the vehicle while using the jack.
- Do not put anything on top of or underneath the jack.

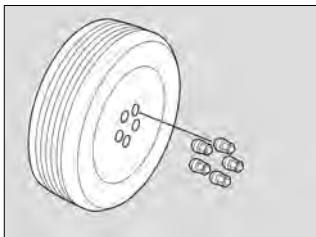
**Replacing the Flat Tire**

- [1] Remove the wheel nuts and flat tire.



- [2] Wipe the mounting surfaces of the wheel with a clean cloth.  
 [3] Mount the compact spare tire.  
 [4] Screw the wheel nuts until they touch the lips around the mounting holes, then stop rotating.

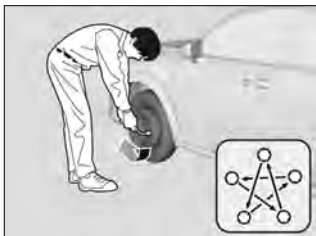

- [5] Lower the vehicle and remove the jack. Tighten the wheel nuts in the order indicated in the image. Go around tightening the nuts two to three times in this order. Wheel nut torque:  
 80 lbf·ft (108 N·m, 11 kgf·m)

Do not over tighten the wheel nuts by applying extra torque using your foot or a pipe.

## Storing the Flat Tire

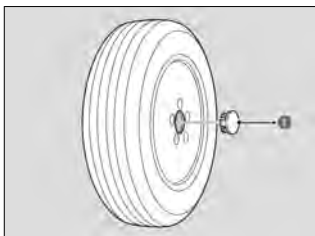

[1] Remove the center cap (1).



[2] Place the flat tire face down in the spare tire well.

[3] Remove the spacer cone from the wing bolt, flip it over, and insert it back on the bolt. Secure the flat tire with the wing bolt.

[4] Securely store the jack, wheel nut wrench, and jack handle bar back in the tool case.

[5] Store the case in the cargo area.

### ⚠ WARNING

Loose items can fly around the interior in a crash and can seriously injure the occupants.

Store the wheel, jack, and tools securely before driving.

7

Handling the Unexpected

## TPMS and the Spare Tire

If you replace a flat tire with the spare tire, the Low Tire Pressure/TPMS indicator comes on while you are driving. After driving for a few miles (kilometers), **Tire pressure monitor system problem. Check tire pressure. See your dealer.** will appear on the driver information interface and the indicator will start blinking for a short time and then stay on; however, this is normal and is no cause for concern. If you replace the tire with a full-size tire, the warning message on the driver information interface and the Low Tire Pressure/TPMS indicator will go off after a few miles (kilometers).

The system cannot monitor the pressure of the spare tire. Manually check the spare tire pressure to be sure that it is correct.

Use the TPMS specific wheels. Each is equipped with a tire pressure sensor mounted inside the tire behind the valve stem.

# Engine Does Not Start

## Checking the Engine

If the engine does not start, check the following items and take appropriate action.

### Starter doesn't turn or turns over slowly.

The 12-volt battery may be dead. Check each of the items on the right and respond accordingly.

- Check for a message on the driver information interface.

If the **To start, touch start button with emblem side of remote** message appears:

 [If the Keyless Remote Battery is Weak ▶P.413](#)

- Check the fuses.

Check all fuses, or have your vehicle checked by a dealer.

 [Inspecting and Changing Fuses ▶P.425](#)

### The starter turns over normally but the engine doesn't start.

There may be a problem with a fuse. Check each of the items on the right and respond accordingly.

- Review the engine start procedure.

Follow its instructions, and try to start the engine again.

 [Starting the Engine ▶P.105](#)

- Check the immobilizer system indicator.

When the immobilizer system indicator is blinking, the engine cannot be started.

 [Immobilizer System ▶P.49](#)

 [Indicator List ▶P.335](#)

- Check the fuel level.

There should be enough fuel in the tank.

 [Fuel Gauge ▶P.343](#)

- Check the fuses.

Check all fuses, or have the vehicle checked by a dealer.

 [Inspecting and Changing Fuses ▶P.425](#)

- If the problem continues:

 [About Towing ▶P.427](#)

- If you must start the vehicle immediately, use an assisting vehicle or booster battery to jump start it.

 [Jump Starting Procedure ▶P.415](#)

- Depending on the situation, it may be possible to temporarily start the engine using the emergency starting procedure.

## If the Keyless Remote Battery is Weak

Follow the steps below if **ENGINE START/STOP** button does not turn on the power or start the engine.

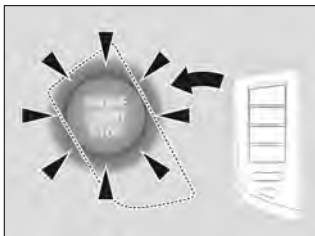

- [1] Press the **ENGINE START/STOP** button.
- [2] Touch the center of the **ENGINE START/STOP** button with the keyless remote within 30 seconds. The buttons on the keyless remote should be facing you.
- [3] Depress and hold the brake pedal, then press the **ENGINE START/STOP** button within 10 seconds.
  - » If you don't depress the pedal, the mode will change to ACCESSORY.

## Emergency Engine Stop

The **ENGINE START/STOP** button may be used to stop the engine due to an emergency situation even while driving. If you must stop the engine, do either of the following operations:

- Press and hold the **ENGINE START/STOP** button for about two seconds.
- Firmly press the **ENGINE START/STOP** button three times.
- The steering wheel will not lock.

**!** If the power mode is set to ACCESSORY while driving, the engine will shut down and all steering and brake power assist functions will stop, making it difficult to control the vehicle.

## Emergency Engine Start

If the engine cannot be started using the normal starting procedure, you may be able to start using the emergency starting procedure below.

Do not use this procedure if it is not an emergency.

- [1] Make sure the parking brake is applied.
- [2] Check that the transmission is in **P**, then set the power mode to ACCESSORY.
- [3] Firmly depress the brake pedal, then press and hold the **ENGINE START/STOP** button for at least 15 seconds.

This should be considered a system malfunction even if you are able to start the engine using the above procedure.

Have your vehicle checked by a dealer immediately.

Refer to the following if you cannot move the shift lever out of the **P** position.

 Releasing the Lock ▶ P.417

# If the 12-volt Battery Is Dead

## Jump Starting Procedure

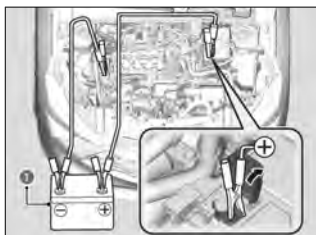

- [1] Turn off the power to electric devices, such as audio and lights.
- [2] Set your vehicle and the assisting vehicle's power modes to OFF.
- [3] Connect the first jumper cable to the  $\oplus$  terminal of your vehicle's 12-volt battery.
- [4] Connect the other end of the first jumper cable to the  $\oplus$  terminal of the assisting vehicle's battery (1).

» When using an automotive battery charger to boost your 12-volt battery, select a lower charging voltage than 15-volt. Check the charger manual for the proper setting.

- [5] Connect the second jumper cable to the  $\ominus$  terminal of the assisting vehicle's battery.
- [6] Connect the other end of the second jumper cable to your vehicle's engine mounting bolt (1).
- [7] Start the assisting vehicle's engine and increase its RPM slightly.
- [8] Start your vehicle's engine.

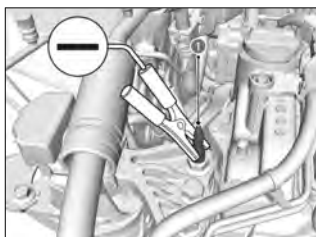

- Use a 12-volt booster battery only.

**!** Securely attach the jumper cables' clips so that they do not come off when the engine vibrates. Be careful not to tangle the jumper cables or allow the cable ends to touch each other while attaching or detaching the jumper cables.

**!** 12-volt battery performance degrades in cold conditions and may prevent the engine from starting.





## WARNING

A 12-volt battery can explode if you do not follow the correct procedure, seriously injuring anyone nearby.  
Keep all sparks, open flames, and smoking materials away from the battery.

## What to Do After the Engine Starts

Once your vehicle's engine has started, remove the jumper cables in the following order.

- [1] Disconnect the jumper cable from your vehicle's ground.
- [2] Disconnect the other end of the jumper cable from the booster battery  terminal.
- [3] Disconnect the jumper cable from your vehicle's battery  terminal.
- [4] Disconnect the other end of the jumper cable from the booster battery  terminal.

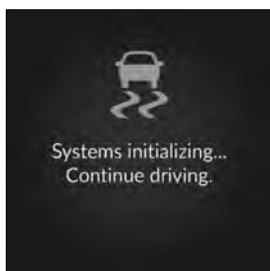

After re-connecting the 12-volt battery: if various indicators come on and the message on the left is displayed on the driver information interface, drive a short distance at more than 12 mph (20km/h). If the indicator does not go off, have your vehicle checked by a dealer.

# Shift Lever Does Not Move

## Releasing the Lock

Follow the procedure below if you cannot move the shift lever out of the **P** position.



- [1] Set the parking brake.
- [2] Remove the built-in key from the keyless remote.
- [3] Insert the key into the shift lock release slot.

### 1 Slot



- [4] While pushing the key down, press the shift lever release button, and place the shift lever into **N**.
  - » The lock is now released. Have the shift lever checked by a dealer as soon as possible.

### 1 Release Button

# Overheating

## How to Handle Overheating



Overheating symptoms are as follows:

- The temperature gauge is at the **H** mark or the engine suddenly loses power.
- The **Engine temperature too hot. Do not drive. Allow engine to cool.** message appears on the driver information interface.
- Steam or spray comes out of the engine compartment.

### WARNING

Steam and spray from an overheated engine can seriously scald you.  
Do not open the hood if steam is coming out.

### WARNING

Removing the radiator cap while the engine is hot can cause hot coolant to spray out, seriously scalding you.  
Always let the engine and radiator cool down before removing the radiator cap.

 Continuing to drive with the temperature gauge at the **H** mark may damage the engine.

 Continuing to drive with the **Engine temperature too hot. Do not drive. Allow engine to cool.** message on the driver information interface may damage the engine.

## The Engine temperature too hot. Do not drive. Allow engine to cool. Message Appears on the Driver Information Interface

- [1] Immediately park the vehicle in a safe place.
- [2] Turn off all accessories and turn on the hazard warning lights.
  - » No steam or spray present: Keep the engine running and open the hood.
  - » Steam or spray is present: Turn off the engine and wait until it subsides. Then, open the hood.



- 1 Reserve Tank
- 2 MAX
- 3 MIN

- [3] Check that the cooling fan is operating and stop the engine once the temperature gauge goes down.
  - » If the cooling fan is not operating, immediately stop the engine.
- [4] Once the engine has cooled down, inspect the coolant level and check the cooling system components for leaks.
  - » If the coolant level in the reserve tank is low, add coolant until it reaches the **MAX** mark.
  - » If there is no coolant in the reserve tank, check that the radiator is cool. Cover the radiator cap with a heavy cloth and open the cap. If necessary, add coolant up to the base of the filler neck, and put the cap back on.

- If the coolant is leaking, contact a dealer for repairs.

Use water as an emergency/temporary measure only. Have a dealer flush the system with proper antifreeze as soon as possible.

# When a Warning Appears

## If the Engine oil pressure low. Warning Appears



Engine oil pressure  
low.  
Stop engine.  
Do not drive.



Running the engine with low oil pressure can cause serious mechanical damage almost immediately.



### Reasons for the warning to appear

Appears when the engine oil pressure is low.

### What to do as soon as the warning appears

- [1] Immediately park the vehicle on level ground in a safe place.
- [2] If necessary, turn the hazard warning lights on.

### What to do after parking the vehicle

- [1] Stop the engine and let it sit for approximately three minutes.
  - [2] Open the hood and check the oil level.
    - » Add oil as necessary.
-  Oil Check  P.369
- [3] Start the engine and check the low oil pressure warning.
    - » The warning disappears: Start driving again.
    - » The warning does not disappear within 10 seconds: Immediately stop the engine and contact a dealer for repairs.

# Fuses

## Checking Fuses

If any electrical devices are not working, set the power mode to VEHICLE OFF and check to see if any applicable fuse is blown.

### Engine Compartment Fuse Box

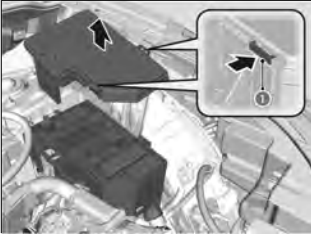

Located on the driver's side.  
» Push the tabs (1) to open the box.

Fuse locations are shown on the fuse box cover or image below.  
Locate the fuse in question by the fuse number.

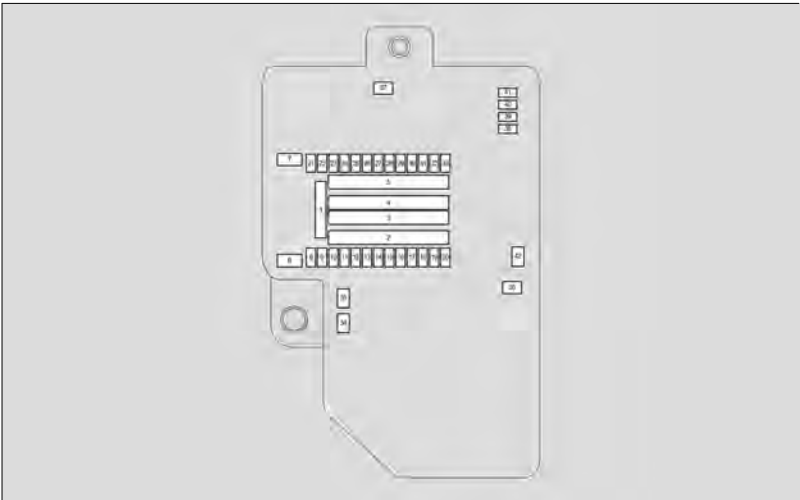

## Circuit Protected and Fuse Rating

	Circuit Protected	Amps
1	— BATTERY	150 A
	— A/C PTC1*	(40 A)
	— A/C PTC3*	(40 A)
2	— F/BOX OPTION1	60 A
	— AUDIO AMP*	(40 A)
	— F/BOX OPTION2	40 A
	— —	30 A
	— F/BOX MAIN	60 A
3	— —	30 A
	— —	30 A
	— —	70 A
	— RR DEFROSTER	30 A
	— PTG MTR	40 A
	— —	30 A
	— HTR MTR	40 A
	— BOOSTER MTR	40 A
	— ABS/VSA MTR	40 A
	— —	40 A
4	— DC/DC1	30 A
	— IG MAIN	30 A
	— —	30 A
	— IG MAIN2	30 A
	— ST MAGNETIC SW	30 A
	— WIPER	30 A
	— EPS	70 A
5	— —	30 A
	— ABS/VSA FSR	40 A
	— MAIN FAN	30 A
	— F/BOX MAIN2	40 A
6	— SUB FAN	30 A
7	— DC/DC2	30 A
8	— —	—
9	— SUNSHADE*	(20 A)

	Circuit Protected	Amps
10	— —	—
11	— FR DEICER	(15 A)
12	— —	—
13	— H/STRG	(10 A)
14	— —	—
15	— FR FOG*	10 A
16	— MG CLUTCH	10 A
17	— WASHER	15 A
18	— HORN	10 A
19	— BACK UP	10 A
20	— —	—
21	— R/M1	20 A
22	— DBW	15 A
23	— R/M2	20 A
24	— BACKUP FI-ECU	10 A
25	— IGP	15 A
26	— TCU	15 A
27	— LCM L	20 A
28	— INJ	20 A
29	— STOP	10 A
30	— LCM R	20 A
31	— IG COIL	15 A
32	— —	—
33	— HAZARD	10 A
34	— —	—
35	— —	—
36	— —	—
37	— BACKUP2	30 A
38	— —	—
39	— —	—
40	— VBACT	7.5 A
41	— IGPS LAF	7.5 A
42	— MON2	10 A

\*: Not available on all models

## Interior Fuse Box

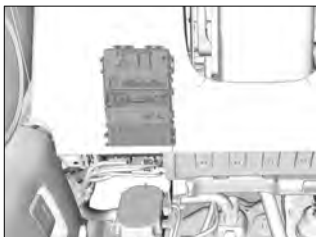

Located under the dashboard.

Fuse locations are shown on the image below.

Locate the fuse in question by the fuse number in the image and chart.

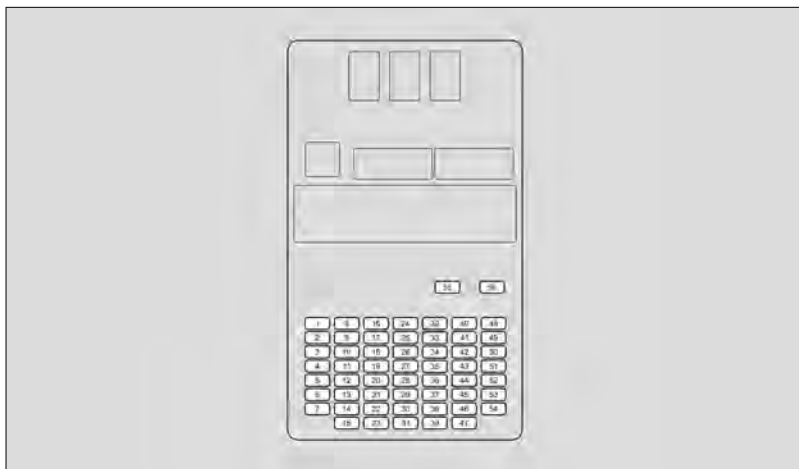

### Circuit Protected and Fuse Rating

	Circuit Protected	Amps
1	— P/W DR	20 A
2	— P/W AS	20 A
3	— P/W RR R	20 A
4	— P/W RR L	20 A
5	— OPTION	10 A
6	— SRS	10 A
7	— —	—

	Circuit Protected	Amps
8	— —	—
9	— FR ACC SOCKET	20 A
10	— DOOR LOCK	20 A
11	— METER	10 A
12	— ST CUT RLY	10 A
13	— OPTION2 (EBB)	10 A
14	— OPTION6 (VB SOL)	10 A



	Circuit Protected	Amps
15	DR DOOR UNLOCK	10 A
16	SUNROOF	20 A
17	—	—
18	—	—
19	INTR LT	7.5 A
20	—	—
21	CARGO ACC SOCKET	20 A
22	SMART	10 A
23	DR DOOR LOCK	10 A
24	—	—
25	IMG	10 A
26	SRS	10 A
27	ACG	10 A
28	OPTION5 (ABS)	10 A
29	FUEL PUMP	15 A
30	L SIDE DOOR UNLOCK	10 A
31	R SIDE DOOR UNLOCK	10 A
32	FR USB	10 A
33	RR USB*	(10 A)
34	—	—
35	CTR DISP	(7.5 A)

	Circuit Protected	Amps
36	PTG CLOSER	20 A
37	—	—
38	—	—
39	R SIDE DOOR LOCK	10 A
40	P/SEAT REC / RR HI	20 A
41	P/SEAT SLIDE / FR HI	20 A
42	—	—
43	OPTION	10 A
44	DRL	10 A
45	ACC	10 A
46	ACC KEY LOCK	10 A
47	L SIDE DOOR LOCK	10 A
48	H/SEAT	20 A
49	AS P/SEAT REC*	(20 A)
50	P/LUMBAR DR*	(10 A)
51	—	—
52	E-DPS	20 A
53	AS P/SEAT SLI*	(20 A)
54	OPTION1 / FUEL LID	10 A
55	—	—
56	—	—

## Interior Sub Fuse Box

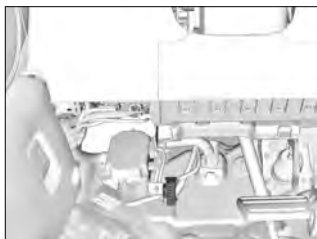

Located under the dashboard.

Fuse locations are shown on the image below.

Locate the fuse in question by the fuse number in the image and chart.

\*: Not available on all models



## Circuit Protected and Fuse Rating

	Circuit Protected	Amps
A	- BACKUP2 AUDIO	15 A
B	- VSA VST	7.5 A
C	- METER VST	5 A
D	- BACK UP2 AIRCON	7.5 A

	Circuit Protected	Amps
E	- -	-
F	- ACC VST	7.5 A
G	EOP	7.5 A

## Inspecting and Changing Fuses



- [1] Set the power mode to VEHICLE OFF. Turn headlights and all accessories off.
- [2] Remove the fuse box cover.
- [3] Check the main fuse in the engine compartment fuse box.
  - » Look at the fuse through the hole.
  - » If the fuse is blown, have it replaced by a dealer.

### 1 Hole

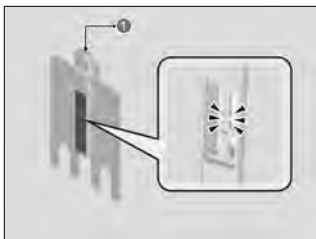

### 1 Main Fuse

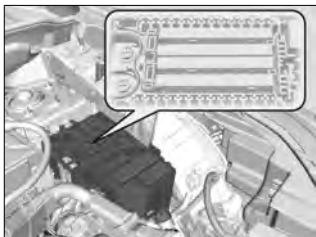

- [4] Check the combined fuses in the engine compartment fuse box.
- » Look into the space between the fuses.
  - » If the fuse is blown, have it replaced by a dealer.

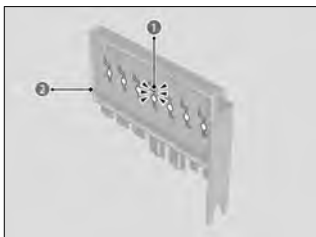

- 1 Blown Fuse
- 2 Combined Fuse

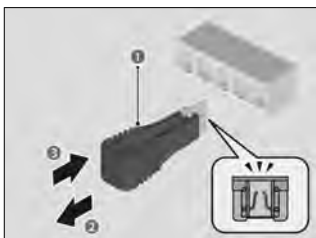

- [5] Inspect the small fuses in the engine compartment and the vehicle interior.
- » If there is a blown fuse, remove it with the fuse puller and replace it with a new one.

- 1 Fuse Puller
- 2 Remove
- 3 Replace

- Replacing a fuse with one that has a higher rating greatly increases the chances of damaging the electrical system.
- Use the charts to locate the fuse in question and confirm the specified amperage on the fuse label.
- Replace with a fuse of the same specified amperage.

There is a fuse puller in the engine compartment fuse box cover.

# Emergency Towing

## About Towing

### Flatbed Equipment

#### ▼ 2WD Models

The operator loads your vehicle on the back of a truck. This is the best way to transport your vehicle.

#### ▼ AWD Models

The operator loads your vehicle on the back of a truck. This is the only way you can safely transport your vehicle. Any other towing method will damage the vehicle's drive system.

### Wheel Lift Equipment

#### ▼ 2WD Models

The tow truck uses two pivoting arms that go under the front tires and lift them off the ground. The rear tires remain on the ground. This is an acceptable way to tow your vehicle.

#### ▼ All Models

Call a professional towing service if you need to tow your vehicle.

- Trying to lift or tow your vehicle by the bumpers will cause serious damage. The bumpers are not designed to support the vehicle's weight.

#### ▼ 2WD Models

- Make sure the parking brake is released. If you cannot release the parking brake, your vehicle must be transported by the flatbed equipment.

 [Parking Brake](#) ▶ [P.114](#)

Never tow your vehicle with just a rope or chain.

It is very dangerous because ropes or chains may shift from side to side or break.



Improper towing such as towing behind a motorhome or other motor vehicle can damage the transmission.

# If You Cannot Unlock the Fuel Fill Door

## What to Do If Unable to Unlock the Fuel Fill Door

If you cannot unlock the fuel fill door, use the following procedure.



[1] Open the tailgate and remove the cover.

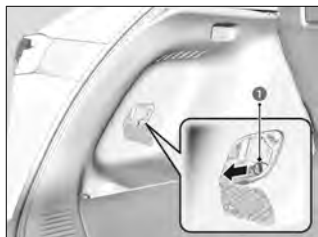

[2] Pull the release cord as shown.

» You can open the fuel fill door.

 How to Refuel  P.134

### 1 Release Cord

After taking these steps, contact a dealer to have the vehicle checked.

# If You Cannot Open the Tailgate

## What to Do If Unable to Open the Tailgate

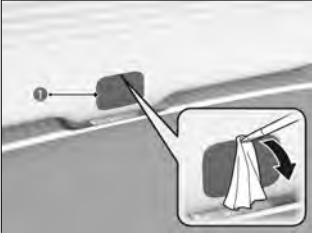

- [1] Use a flat-tip screwdriver and remove the cover on the back of the tailgate.
  - » Wrap the flat-tip screwdriver with a cloth to prevent scratches.

### 1 Cover

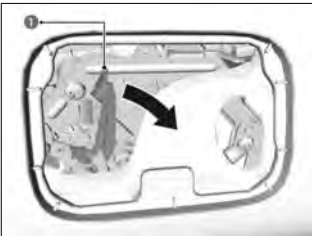

- [2] Push the release lever until the tailgate unlocks. Push the hatch up to open.

### 1 Lever

- Wrap the flat-tip screwdriver with a cloth to prevent scratches.
- Following up:  
After taking these steps, contact a dealer to have the vehicle checked.

# Refueling

## Refueling From a Portable Fuel Container



**1** Funnel

[1] Turn off the engine.

[2] Open the fuel fill door.

[How to Refuel](#) ▶ P.134

[3] Take the funnel out of the tool case in the cargo area.

[Types of Tools](#) ▶ P.394

[4] Place the end of the funnel on the lower part of filler opening, then insert it slowly and fully.

» Make sure that the end of the funnel goes down along with the filler pipe.

[5] Fill the tank with fuel from the portable fuel container.

» Pour fuel carefully so you do not spill any.

[6] Remove the funnel from the filler neck.

» Wipe up any fuel from the funnel before storing it.

[7] Shut the fuel fill door by hand.

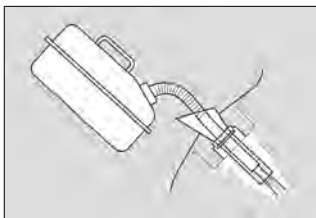

Do not insert the nozzle of a portable fuel container or any funnel other than the one provided with your vehicle. Doing so can damage the fuel system.

Do not try to pry open or push open the sealed fuel tank with foreign objects. This can damage the fuel system and its seal.

Make sure the fuel in the portable fuel container is gasoline before you refuel.

### **WARNING**

Gasoline is highly flammable and explosive.

You can be burned or seriously injured when handling fuel.

- Stop the engine, and keep heat, sparks, and flames away.
- Handle fuel only outdoors.
- Wipe up spills immediately.

# Emergency Call (eCall)\*

## Automatic Emergency Call



If your vehicle is involved in a collision, the vehicle will attempt to connect to an operator. Once a connection is established, your location information will be sent to an operator with whom you will be able to speak.

### 1 eCall Indicator

When an emergency call is initiated, the vehicle speakers are disabled so that you can hear the operator.

When the power mode is set to ON, the eCall indicator lights up in green for 1 second, then in red for 1 second.

If the eCall system is working properly, the indicator will light up in green.

- Green: eCall system is ready.
- Blinking in green: eCall system is connected and making an eCall to an operator.
- Repeating a pattern of short flashes of the red light: The eCall system has failed to connect to an operator. The eCall indicator will continue this pattern for five seconds, then it will light up in green.

If the eCall system is disabled in the event of a critical system failure, the following warning will be given to the occupants of the vehicle:

- Red or blacked out: A problem with the eCall system has occurred. If the indicator stays red or blacked out even after you have restarted the vehicle, have the system check by a dealer.



Your vehicle may NOT be able to connect to an operator if:

The 12-volt battery is too low.

Your vehicle is in an area without adequate cellular coverage.

There is a problem with the eCall system itself or its peripheral equipment such as the microphone or speakers.

\*: Not available on all models



## Manual Emergency Call

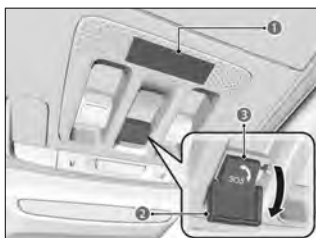

If you need to make an emergency call, you can establish a connection manually. Press the **SOS** button.

To cancel a call, press the **SOS** button for more than two seconds, before 10 seconds have elapsed since the **SOS** button was pressed.

- 1 Microphone
- 2 Cover
- 3 **SOS** Button

The **SOS** button is protected by a cover. Open the cover to gain access.

When an emergency call is initiated, the vehicle speakers are disabled so that you can hear the operator.

! Do NOT press the button while you are driving. If you need to contact an operator, park the vehicle in a safe place before you make a call.

! If the eCall system at first fails to connect to an operator, it will try again until a connection is established. However, if two minutes have elapsed since the first try was attempted, the system will no longer attempt to establish a connection.

! The **SOS** button does not cancel a call once the system is connected to an operator.

## **Specifications**

About Specifications..... 434

## **Identification Numbers**

Vehicle Identification Number (VIN), Engine  
Number, and Transmission Number..... 436

## **Devices that Emit Radio Waves**

About Devices that Emit Radio Waves..... 437

## **Reporting Safety Defects**

About Reporting..... 438

## **Emissions Testing**

Testing of Readiness Codes..... 440

## **Warranty Coverages**

About Warranty Coverages..... 441

## **Authorized Manuals**

If necessary..... 443

## **Client Service Information**

Contacts..... 444

## **Open Source License**

Summary..... 446

# Specifications

## About Specifications

### Basic Information

Model	ADX
No. of Passengers:	
Front	2
Rear	3
Total	5
Weights:	
Gross Vehicle Weight Rating	See the certification label on the driver's doorjamb
Gross Axle Weight Rating (Front)	See the certification label on the driver's doorjamb
Gross Axle Weight Rating (Rear)	See the certification label on the driver's doorjamb

### Air Conditioning

Refrigerant Type	HFO-1234yf (R-1234yf)
Charge Quantity	14.3 – 16.0 oz (405 – 455 g)
Lubricant Type	RB100EV-01 (POE)
Quantity	6.71 – 7.50 cu-in (110 – 123 cm <sup>3</sup> )

### Engine Specifications

Displacement	91.38 cu-in (1,498 cm <sup>3</sup> )
Spark Plugs	NGK DILKAR8P8SY

### Fuel

Type	Unleaded premium gasoline, pump octane number 91 or higher
Fuel Tank Capacity	14.0 US gal (53.0 L)

### Washer Fluid

Tank Capacity	U.S.: 1.6 US qt (1.5 L) Canada: 4.8 US qt (4.5 L)
---------------	--

### Light Bulbs

Headlights (High/Low Beam)	LED
Front Turn Signal Lights	LED
Parking/Chicane™ Daytime Running Lights	LED
Front Side Marker Lights	LED
Fog Lights*	LED
Side Turn Signal Lights (on Door Mirrors)	LED
Brake Lights	LED
Chicane™ Taillights	LED
Rear Turn Signal Lights	LED
Rear Side Marker/Chicane™ Taillights	LED
Back-Up Lights	LED
High-Mount Brake Light	LED
Rear License Plate Light	LED
Front and Rear Map Lights	LED
Cargo Area Lights	LED
Vanity Mirror Lights	LED
Center Console Light	LED
Glove Box Light	LED
Foot Lights*	LED
Door Inner Handle Lights*	LED
Ambient Lights	LED

### Brake Fluid

Specified	Acura Heavy Duty Brake Fluid DOT 3
-----------	------------------------------------

\*: Not available on all models

**Continuously Variable Transmission Fluid**

<b>Specified</b>	Acura HCF-2	
<b>Capacity</b>	<b>Change</b>	3.7 US qt (3.5 L) <sup>*1</sup>
		4.1 US qt (3.9 L) <sup>*2</sup>

\*1: 2WD models

\*2: AWD models

**Rear Differential Fluid\***

<b>Specified</b>	Acura DPSF-II	
<b>Capacity</b>	<b>Change</b>	1.318 US qt (1.247 L)

**Engine Oil**

<b>Recommendation</b>	<ul style="list-style-type: none"> <li>Acura Genuine Motor Oil 0W-20</li> <li>API service SN or higher grade 0W-20</li> </ul>	
	<b>Capacity</b>	<b>Change</b>
<b>Capacity</b>	<b>Change including filter</b>	3.7 US qt (3.5 L)

**Engine Coolant**

<b>Specified</b>	Acura Long Life Antifreeze/Coolant Type 2	
<b>Ratio</b>	50/50 with distilled water	
<b>Capacity</b>	1.61 US gal (6.09 L)	
	(change including the remaining 0.17 US gal (0.65 L) in the reserve tank)	

**Tire**

<b>Regular</b>	<b>Size</b>	225/55R18 98H 235/45R19 95H
	<b>Pressure psi (kPa [kgf/cm<sup>2</sup>])</b>	Front: 35 (240 [2.4]) Rear: 33 (230 [2.3])
	<b>Size</b>	T135/90D17 104M
<b>Compact Spare*</b>	<b>Pressure psi (kPa [kgf/cm<sup>2</sup>])</b>	60 (420 [4.2])
<b>Wheel Size</b>	<b>Regular</b>	18 x 7J <sup>*1</sup> 19 x 8J <sup>*2</sup>
	<b>Compact Spare*</b>	17 x 4T

For the tire size and pressure information, see the label on driver's doorjamb.

\*1: Models with 18 inch wheel

\*2: Models with 19 inch wheel

\*: Not available on all models

# Identification Numbers

## Vehicle Identification Number (VIN), Engine Number, and Transmission Number

Your vehicle has a 17-digit vehicle identification number (VIN) used to register your vehicle for warranty purposes, and for licensing and insuring your vehicle. The locations of your vehicle's VIN, engine number, and transmission number are shown as follows.

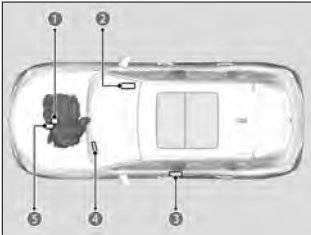

- ❶ Engine Number
- ❷ Vehicle Identification Number
- ❸ Certification Label/Vehicle Identification Number
- ❹ Vehicle Identification Number
- ❺ Continuously Variable Transmission Number

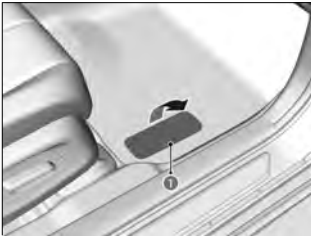

The interior vehicle identification number (VIN) is located under the cover.

- ❶ Cover

# Devices that Emit Radio Waves

## About Devices that Emit Radio Waves

Each radio frequency device installed in the vehicle conforms to the requirements and standards of the regulation listed below:

As required by the FCC:

This device complies with Part 15 of the FCC rules. Operation is subject to the following two conditions: (1) This device may not cause harmful interference, and (2) this device must accept any interference received, including interference that may cause undesired operation.

Changes or modifications not expressly approved by the party responsible for compliance could void the user's authority to operate the equipment.

This device complies with Industry Canada licence-exempt RSS standard(s). Operation is subject to the following two conditions: (1) this device may not cause interference, and (2) this device must accept any interference, including interference that may cause undesired operation of the device.

### ▼ Canadian models

#### Telematics Control Unit

ISED RF exposure

IC Radiation Exposure Statement:

This equipment complies with IC radiation exposure limits set forth for an uncontrolled environment.

This equipment should be installed and operated with minimum distance 20 cm between the radiator & your body.

**NOTE: THE MANUFACTURER IS NOT RESPONSIBLE FOR ANY RADIO OR TV INTERFERENCE CAUSED BY UNAUTHORIZED MODIFICATIONS TO THIS EQUIPMENT. SUCH MODIFICATIONS COULD VOID THE USER'S AUTHORITY TO OPERATE THE EQUIPMENT.**

# Reporting Safety Defects

## About Reporting

In the U.S.

If you believe that your vehicle has a defect which could cause a crash or could cause injury or death, you should immediately inform the National Highway Traffic Safety Administration (NHTSA) in addition to notifying American Honda Motor Co., Inc.

If NHTSA receives similar complaints, it may open an investigation, and if it finds that a safety defect exists in a group of vehicles, it may order a recall and remedy campaign. However, NHTSA cannot become involved in individual problems between you, your dealer, or American Honda Motor Co., Inc.

To contact NHTSA, you may call the Vehicle Safety Hotline toll-free at 1-888-327-4236 (TTY: 1-877-561-7439); go to <http://www.safercar.gov>; or write to: Administrator, NHTSA, 1200 New Jersey Avenue, SE., Washington, DC 20590. You can also obtain other information about motor vehicle safety from <http://www.safercar.gov>.

In Canada

If you believe that your vehicle has a defect which could cause a crash or could cause injury or death, you should immediately inform Honda Canada Inc. and you may also inform Transport Canada.

If Transport Canada receives similar complaints, it may open an investigation, and if it finds that a safety defect exists in a group of vehicles, it may lead to a recall and remedy campaign. However, Transport Canada cannot become involved in individual problems between you, your dealer, or Honda Canada Inc.

To contact Transport Canada's Defect Investigations and Recalls Division, you may call 1-800-333-0510. For more information on reporting safety defects or about motor vehicle safety, go to <http://www.tc.gc.ca/roadsafety>.



# Emissions Testing

## Testing of Readiness Codes

Your vehicle has readiness code as part of the onboard self diagnostic system.

Some states use these codes for testing to verify whether your vehicle's emissions components are working properly.

The codes may not be read properly if testing is performed just after the battery has gone dead or been disconnected.

To check if they are set, set the power mode to ON, without starting the engine. The malfunction indicator lamp will come on for several seconds. If it then goes off, the readiness codes are set. If it blinks five times, the readiness codes are not set.

If you are required to have your vehicle tested before the readiness codes are ready, prepare the vehicle for retesting by doing the following:

- [1] Fill the gas tank to approximately 3/4 full.
- [2] Drive the vehicle for about 10 minutes, reaching 50 to 60 mph (80 to 97 km/h) at least once during this drive.
- [3] Park the vehicle and leave the engine off for 6 hours or more.
- [4] Make sure the ambient temperature is between 40°F and 95°F (4°C and 35°C).
- [5] Start the engine without touching the accelerator pedal, and let it idle for 20 seconds.
- [6] Keep the vehicle in **P**. Increase the engine speed to 2,000 rpm, and hold it there for about 3 minutes.
- [7] Let the engine idle with your foot off the accelerator for 20 seconds.
- [8] Select a nearby, lightly traveled major highway where you can maintain a speed of 50 to 60 mph (80 to 97 km/h) for at least 20 minutes. Drive on the highway in **D**. Do not use cruise control. When traffic allows, drive for 90 seconds without moving the accelerator pedal. (Vehicle speed may vary slightly; this is okay.) If you cannot do this for a continuous 90 seconds because of traffic conditions, drive for at least 30 seconds, then repeat it two more times (for a total of 90 seconds).
- [9] Drive in city or suburban traffic for at least 10 minutes. When traffic conditions allow, let the vehicle coast for several seconds without using the accelerator pedal or the brake pedal.
- [10] Park the vehicle and leave the engine off for 30 minutes.
- [11] If this procedure is done immediately after losing 12-volt battery power, several additional hours of driving may be required to set all codes.

If a testing facility determines that the readiness codes are not set, you may be requested to return at a later date to complete the test.

If the testing facility determines the readiness codes are still not set, see a dealer.

# Warranty Coverages

## About Warranty Coverages

### U.S. Owners

Your new vehicle is covered by these warranties:

**New Vehicle Limited Warranty** – covers your new vehicle, except for the emissions control systems and accessories, against defects in materials and workmanship.

**Emissions Control Systems Defects Warranty and Emissions Performance Warranty** – these two warranties cover your vehicle's emissions control systems. Time, mileage, and coverage are conditional. Please read your warranty booklet for exact information.

**Seat Belt Limited Warranty** – a seat belt that fails to function properly is covered by a limited warranty. Please read your warranty booklet for details.

**Rust Perforation Limited Warranty** – all exterior body panels are covered against rusting from the inside out for the specified time period, regardless of mileage.

**Accessory Limited Warranty** – Acura accessories are covered under this warranty. Time and mileage limits depend on the type of accessory and other factors. Please read your warranty booklet for details.

**Replacement Parts Limited Warranty** – covers all Acura replacement parts against defects in materials and workmanship.

**Replacement 12-Volt Battery Limited Warranty** – provides prorated coverage for a replacement battery purchased from your dealer.

**Replacement Muffler Lifetime Limited Warranty** – provides coverage for as long as the purchaser of the muffler owns the vehicle.

Restrictions and exclusions apply to all these warranties. Please read the Acura warranty information booklet that came with your vehicle for precise information on warranty coverages. Your vehicle's original tires are covered by their manufacturer. Tire warranty information is in a separate booklet.

## ■ Statement on Warranty Coverage for Aftermarket and Recycled Parts

The Magnuson-Moss Warranty Act, 15 U.S.C. s.2301 et seq., makes it illegal for motor vehicle manufacturers to void a motor vehicle warranty or deny warranty coverage solely because an aftermarket or recycled part has been used to repair the vehicle or someone other than the authorized service provider performed service on the vehicle.

This provision does not apply to a new motor vehicle purchased solely for commercial or industrial use.

Under federal law, a manufacturer may deny warranty coverage and charge for repairs to a vehicle if it is discovered that an aftermarket or recycled part installed on the vehicle is defective or was installed incorrectly and caused damage to another part of the vehicle otherwise covered under warranty.

The Federal Trade Commission requires that a manufacturer demonstrate that an aftermarket or recycled part or service performed by a person other than an authorized service provider caused damage to another part of the vehicle otherwise covered under warranty before denying warranty coverage.

Additionally, federal law allows a manufacturer to void a motor vehicle warranty or deny warranty coverage if the manufacturer provides the article or service to consumers free of charge under the warranty or the manufacturer has secured a waiver from the Federal Trade Commission.

## ■ Canadian Owners

Please refer to the warranty manual that came with your vehicle.

## ■ EPA Contact Information

An owner may obtain further information concerning emission warranties or report violations of the terms of the emission warranties by contacting:

Director,  
Light-Duty Vehicle Center,  
U.S. Environmental Protection Agency,  
Attention: Warranty Claim  
2000 Traverwood Drive,  
Ann Arbor, MI 48105;  
[complianceinfo@epa.gov](mailto:complianceinfo@epa.gov)

# Authorized Manuals

## If necessary

### Service Express

For electronic copies of service publications, you can purchase a subscription to Service Express. Visit [www.techinfo.acura.com](http://www.techinfo.acura.com) for pricing and options.

### For U.S. Owners

Manuals can be purchased from Helm Incorporated. You can order a manual by phone at 1 (800) 782-4356 (credit card orders only), or online at [www.helminc.com](http://www.helminc.com).

### For Canadian Owners

Please contact a dealer to order any manuals that you may require.

# Client Service Information

## Contacts

Acura dealership personnel are trained professionals able to deal with any problems you may encounter with your vehicle. If, however, you are faced with a problem that they cannot resolve to your satisfaction, contact Acura Client Relations/Services.

### U.S. Owners

American Honda Motor Co., Inc.  
Acura Client Relations  
Mail Stop CHI-4  
1919 Torrance Blvd.  
Torrance, CA 90501-2746  
Tel: 1 (800) 382-2238

### Canadian Owners

Honda Canada Inc.  
Acura Client Services  
180 Honda Boulevard  
Markham, ON  
L6C 0H9  
Tel: 1-888-9-ACURA-9  
Fax: 1-877-939-0909  
E-mail: [acura\\_cr@ch.honda.com](mailto:acura_cr@ch.honda.com)

### In Puerto Rico and the U.S. Virgin Islands

Bella International  
P.O. Box 190816  
San Juan, PR 00919-0816  
Tel: 1 (787) 620-7546

### In Guam

Triple J Autogroup  
157 S. Marine Corps Drive  
Tamuning, GU 96913  
Tel: (671) 648-2277

When you call or write, please give us the following information:

- Vehicle Identification Number

 Vehicle Identification Number (VIN), Engine Number, and Transmission Number  
▶ P.436

- Date of purchase
- Odometer reading of your vehicle
- Your name, address, and telephone number
- A detailed description of the problem
- Name of the dealer who sold the vehicle to you

# Open Source License

## Summary

### ■ Meter Open Source License

The software embedded in this product includes open source software. Refer to the following website for details regarding the open source software.

[https://www.nippon-seiki.co.jp/business\\_ic\\_meter/](https://www.nippon-seiki.co.jp/business_ic_meter/)

### ■ TCU Open Source License

To obtain the source code under GPL, LGPL, MPL, and other open source licenses that have the obligations to disclose source code, that is contained in this product, and to access all referred license terms, copyright notices and other relevant documents please visit <https://opensource.lge.com>. LG Electronics will also provide open source code to you on CD-ROM for a charge covering the cost of performing such distribution (such as the cost of media, shipping, and handling) upon email request to [opensource@lge.com](mailto:opensource@lge.com). This offer is valid to anyone in receipt of this information for a period of three years after our last shipment of this product.

### ▼ Models with 9" Color Touchscreen

### ■ Audio Open Source License

This product contains software modules available for use under open-source licenses. For detailed information and relevant source code, refer to the following URL.

<https://forvia.top/oss/honda/25sa/>

# Index

## Numbers

- 12-volt Battery ..... 387
  - If the Battery Is Dead ..... 415
  - Maintenance (Checking the 12-volt Battery) ..... 387
  - Maintenance (Replacing) ..... 387
- 12-Volt Battery Charging System Indicator ..... 338
- 7-Speed Manual Shift Mode ..... 111
- 9" Color Touchscreen ..... 199
- 9" Color Touchscreen with Google built-in ..... 218

## A

- ABS (Anti-lock Brake System) ..... 119
- Accessory Power Socket ..... 169
- Acura Integrated Dynamics System ..... 152
  - Dynamic Mode Switch ..... 152
- AcuraLink® ..... 231
- AcuraWatch™ ..... 278
- Adaptive Cruise Control (ACC) with Low Speed Follow ..... 300
  - Indicator (Amber) ..... 340
  - Indicator (White/Green) ..... 301
- Adding the Coolant ..... 373
- Additives
  - Coolant ..... 371
  - Engine Oil ..... 368
  - Washer ..... 374
- Additives, Engine Oil ..... 368
- Adjusting
  - Front Seats ..... 70
  - Head Restraints ..... 70, 72
  - Mirrors ..... 85
  - Rear Seats ..... 72
  - Steering Wheel ..... 67
- Agile Handling Assist ..... 161
- Air Conditioning System (Climate Control System) ..... 184
  - Changing the Mode ..... 184
  - Defrosting the Windshield and Windows ..... 149
  - Dust and Pollen Filter ..... 389
  - Recirculation/Fresh Air Mode ..... 184
  - Sensors ..... 187
  - Synchronization Mode ..... 186
  - Using Automatic Climate Control ..... 185
- Air Pressure ..... 435
- Airbags ..... 33
  - Advanced Airbags ..... 37

- After a Collision ..... 33
- Airbag Care ..... 45
- Event Data Recorder ..... 4
- Front Airbags (SRS) ..... 35
- Indicator ..... 43, 338
- Knee Airbags ..... 39
- Passenger Airbag Off Indicator ..... 44
- Sensors ..... 34
- Side Airbags ..... 40
  - Side Curtain Airbags ..... 42
- All-Wheel Drive (AWD) ..... 161
- AM/FM Radio ..... 201, 225
- Android Auto™ ..... 208, 237
- Anti-lock Brake System (ABS) ..... 119
  - Indicator ..... 339
- Apple CarPlay ..... 206, 234
- Armrest
  - Front Seat ..... 72
  - Rear Seat ..... 73
- AT&T Hotspot ..... 233
- Audio Playback via Bluetooth® Device ..... 229
- Audio Remote Controls ..... 193
- Audio System
  - About Audio Playback ..... 202, 227
  - Adjusting the Sound ..... 200, 223
  - Alexa Built-In ..... 224
  - AM/FM Radio ..... 201, 225
  - Android Auto™ ..... 208, 237
  - Apple CarPlay ..... 206, 234
  - Bluetooth® Audio ..... 205
  - Bluetooth® Audio ..... 229
  - Display Setup ..... 200, 223
  - General Information ..... 259
  - Google built-in ..... 240
  - Home Screen ..... 219
  - How to Update Wirelessly ..... 220
  - Reactivating ..... 188
  - Remote Controls ..... 193
  - Selecting an Audio Source ..... 189, 190
  - Status bar ..... 189, 191
  - System Updates ..... 220
  - Theft Protection ..... 188
  - USB Flash Drives ..... 204, 228, 259
  - USB Ports ..... 192
  - Wired Connection ..... 203, 227
- Authorized Manuals ..... 443
- Auto Door Locking/Unlocking ..... 64



Auto High-Beam	141
Indicator	141
Auto Idle Stop	154
OFF Button	156
Automatic Brake Hold	116
Indicator	118
Automatic Brake Hold System	
Indicator	117
Automatic Folding Door Mirror	86
Automatic Intermittent Wipers	147
Automatic Lighting	138
Average Fuel Economy	347
Average Speed	347
AWD (All-Wheel Drive)	161
AWD Torque Distribution Monitor	350

## B

Battery	387
12-Volt Battery Charging System Indicator	338
Maintenance (Checking the Battery)	388
Maintenance (Replacing)	397
Belts (Seat)	77
Beverage Holders	175
Blind Spot Information System	323
Bluetooth® Audio	205
Bluetooth® Audio	229
Bluetooth® HandsFreeLink®	209
Bluetooth® HandsFreeLink®	244
Booster Seats (For Children)	30
Brake System	
Anti-lock Brake System (ABS)	119
Automatic Brake Hold	116
Brake Assist System	113
Fluid	374
Foot Brake	113
Indicator (Amber)	338
Indicator (Red)	337
Parking Brake	114
Brightness	352
Built-in Key	52
Bulb Replacement	396
Back-Up Lights	396
Brake Lights	396
Chicane™ Taillights	396
Fog Lights	396
Front Side Marker Lights	396
Front Turn Signal Lights	396
Headlights	396
High-Mount Brake Light	396
Parking/Chicane™ Daytime Running Lights	396
Rear License Plate Light	396
Rear Side Marker/Chicane™ Taillights	396
Rear Turn Signal Lights	396
Side Turn Signal/Emergency Indicator Lights (on Door Mirrors)	396
Bulb Specifications	434

## C

Carbon Monoxide Gas	31
Cargo Area Cover	174
Carrying Cargo	18, 97
CAMERA Button	126
Center Console Box	169
Certification Label	436
Changing Bulbs	396
Chicane™ Daytime Running Lights	141
Child Safety	19
Childproof Door Locks	65
Child Seat	19
Booster Seats	30
Child Seat for Infants	20
Child Seat for Small Children	21
Installing a Child Seat with a Lap/Shoulder Seat Belt	25
Larger Children	29
Rear-facing Child Seat	21
Selecting a Child Seat	22
Using a Tether	27
Childproof Door Locks	65
Cleaning the Exterior	391
Cleaning the Interior	390
Client Service Information	444
Climate Control System	184
Changing the Mode	184
Defrosting the Windshield and Windows	149
Dust and Pollen Filter	389
Recirculation/Fresh Air Mode	184
Sensors	187
Synchronization Mode	186
Using Automatic Climate Control	185
Clock	355
Adjusting the Clock	199, 222
CMBS™ (Collision Mitigation Braking System™)	284
Coat Hook	173

Collision Mitigation Braking System™ (CMBS™) ..... 284

Compact Spare Tire ..... 407, 435

Continuously Variable Transmission ..... 121

- Creeping ..... 121
- Fluid ..... 373
- Kickdown ..... 121
- Operating the Shift Lever ..... 110
- Shift Lever Does Not Move ..... 417
- Shifting ..... 110

Coolant (Engine) ..... 371

- Adding to the Engine Coolant Reserve Tank ..... 372
- Adding to the Radiator ..... 373
- Overheating ..... 418

Creeping (Continuously Variable Transmission) ..... 121

Cross Traffic Monitor ..... 326

Cup Holders ..... 175

Current Mode for Adaptive Cruise Control (ACC) with Low Speed Follow, the Lane Keeping Assist System (LKAS), and Traffic Jam Assist ..... 344

Customize Display ..... 355

Customized Features ..... 214, 249, 352

## D

Dead Battery ..... 415

Defaulting All the Settings ..... 217, 258

Defrosting the Windshield and Windows ..... 149

Devices that Emit Radio Waves ..... 437

Dimming

- Rearview Mirror ..... 85

Dipstick (Engine Oil) ..... 369

Directional Signals (Turn Signal) ..... 138

Door Mirrors ..... 85

Doors

- Auto Door Locking ..... 64
- Auto Door Unlocking ..... 64
- Door and Tailgate Open Message ..... 17
- Keys ..... 48
- Locking/Unlocking the Doors from Inside ..... 63

DOT Tire Quality Grading ..... 382

Driver Attention Monitor ..... 348

Driver Information Interface ..... 346, 355

- Switching the Display ..... 346

Driving

- Braking ..... 113
- Continuously Variable Transmission ..... 121

- Off-Highway Driving Guidelines ..... 101
- Shifting Position ..... 110
- Starting the Engine ..... 105

Driving Position Memory System ..... 74

Dust and Pollen Filter ..... 389

Dynamic Mode Switch ..... 152

## E

Elapsed Time ..... 347

Electric Power Steering (EPS) System

- Indicator ..... 340

Electronic Stability Control (ESC) ..... 160

Emergency ..... 427

Emissions Testing (Readiness Codes) ..... 440

Engine ..... 436

- Coolant ..... 371
- If the Battery Is Dead ..... 415
- Oil ..... 368
- Remote Engine Start ..... 106
- Starting ..... 105

Engine Coolant ..... 371

- Adding to the Engine Coolant Reserve Tank ..... 372
- Adding to the Radiator ..... 373
- Overheating ..... 418
- Temperature Gauge ..... 343

Engine oil pressure low Warning ..... 420

Engine Oil ..... 368

- Adding ..... 369
- Checking ..... 369
- Engine oil pressure low Warning ..... 420
- Recommended Engine Oil ..... 368

Exhaust Gas Hazard (Carbon Monoxide) ..... 31

Exterior Mirrors ..... 85

## F

Filters

- Dust and Pollen ..... 389
- Oil ..... 370

Flat Tire ..... 399

Fluids

- Brake ..... 374
- Continuously Variable Transmission ..... 373
- Engine Coolant ..... 371
- Windshield Washer ..... 374

FM/AM Radio ..... 201, 225

Fog Lights ..... 141

- Indicator ..... 141

- Folding Down the Rear Seats ..... 73
  - Foot Brake ..... 113
  - Front Airbags (SRS) ..... 35
  - Front Seats
    - Adjusting ..... 70
  - Front Wide View Camera ..... 280
  - Fuel ..... 133
    - Average Fuel Economy ..... 347
    - Economy ..... 136
    - Gauge ..... 343
    - Instant Fuel Economy ..... 347
    - Low Fuel Indicator ..... 339
    - Range ..... 346
    - Recommendation ..... 133
    - Refueling ..... 133
  - Fuel Economy ..... 136
  - Fuel Fill Door ..... 134
    - Unable to Unlock ..... 428
  - Fuses ..... 421
    - Inspecting and Changing ..... 425
    - Locations ..... 421, 423, 424
- G**
- Gasoline (Fuel) ..... 133
    - Average Fuel Economy ..... 347
    - Economy ..... 136
    - Gauge ..... 343
    - Information ..... 133
    - Instant Fuel Economy ..... 347
    - Low Fuel Indicator ..... 339
    - Recommendation ..... 133
    - Refueling ..... 133
  - Gauge Display Settings ..... 354
  - Gauges ..... 342
  - Glove Box ..... 169
  - Google built-in ..... 240
- H**
- HandsFreeLink® (HFL) ..... 209
    - Emergency Call (eCall) ..... 431
    - Favorite Contacts ..... 211
    - HFL Status Display ..... 210
    - Making a Call ..... 212
    - Options During a Call ..... 214
    - Phone Setup ..... 214
    - Receiving a Call ..... 213
  - HandsFreeLink® (HFL) ..... 244
    - Automatic Transferring ..... 249
    - Favorite Contacts ..... 246
    - HFL Menus ..... 249
    - HFL Status Display ..... 245
    - Making a Call ..... 247
    - Options During a Call ..... 249
    - Phone Setup ..... 249
    - Receiving a Call ..... 248
    - Ringtones ..... 249
  - Hazard Warning Button ..... 11
  - HD Radio™ ..... 225
  - Head Restraints ..... 69, 70, 72
  - Headlights ..... 138
    - Aiming ..... 396
    - Auto High-Beam ..... 141
    - Operating ..... 138
  - Heated Steering Wheel ..... 179
  - Heated Windshield ..... 151
  - Heater (Steering Wheel) ..... 179
  - Heaters (Seat) ..... 177
  - HFL (HandsFreeLink®) ..... 209, 244
  - High Beam Indicator ..... 140
  - Hill Descent Control System ..... 158
  - Hill Start Assist System ..... 120
  - Honda App License Agreement ..... 260
- I**
- iPhone ..... 259
  - iPod ..... 259
  - Identification Numbers
    - Engine and Transmission ..... 436
    - Vehicle Identification ..... 436
  - Immobilizer System ..... 49
    - Indicator ..... 49
  - Important Handling Information ..... 15
  - Indicators ..... 335
    - 12-Volt Battery Charging System ..... 338
    - Adaptive Cruise Control (ACC) with Low Speed Follow (Amber) ..... 340
    - Adaptive Cruise Control (ACC) with Low Speed Follow (White/Green) ..... 301
    - Anti-lock Brake System (ABS) ..... 339
    - Auto High-Beam ..... 141
    - Auto Idle Stop System (Amber) ..... 340
    - Automatic Brake Hold ..... 118
    - Automatic Brake Hold System ..... 117
    - Electric Power Steering (EPS) System ..... 340
    - Engine oil pressure low Warning ..... 420
    - Fog Light ..... 141

High Beam Indicator	140
Hill Descent Control System	159
Immobilizer System	49
Lane Keeping Assist System (LKAS) (Amber)	340
Lane Keeping Assist System (LKAS) (White/Green)	311
Lights On	138
Low Fuel	339
Low Tire Pressure/TPMS	162, 340
Malfunction Indicator Lamp	338
Parking Brake and Brake System (Amber)	338
Parking Brake and Brake System (Red)	337
Safety Support (Amber)	341
Safety Support (Green/Gray)	351
Seat Belt Reminder	78, 338
Security System Alarm	50
Shift Position	110
Supplemental Restraint System	44, 338
System Message	355
Transmission System	340
Turn Signal Indicators	138
Vehicle Stability Assist™ (VSA®) OFF	161, 339
Vehicle Stability Assist™ (VSA®) System	160, 339
Instant Fuel Economy	347
Integrated Dynamics System	152
Dynamic Mode Switch	152
Interior Lights	167
Interior Rearview Mirror	85

**J**

Jack (Wheel Nut Wrench)	409
Jump Starting	415

**K**

Key Number Tag	52
Keyless Access System	55
Keys	48
Key Number Tag	52
Rear Door Won't Open	65
Remote Transmitter	54
Two-way Keyless Remote	62
Kickdown (Continuously Variable Transmission)	121
Knee Airbags	39

**L**

Lane Keeping Assist System (LKAS)	310
Indicator (Amber)	340
Indicator (White/Green)	311
LATCH (Child Seats)	23
Lights	138, 396
Automatic	138
Bulb Replacement	396
Chicane™ Daytime Running Lights	141
Fog Lights	141
High Beam Indicator	140
Interior	167
Lights On Indicator	138
Turn Signals	138
Load Limits	97
Locking/Unlocking	54
Auto Door Locking	64
Auto Door Unlocking	64
Childproof Door Locks	65
From Inside	63
From Outside	60
Using a Key	60
Using the Keyless Access System	55
Using the Remote Transmitter	54
Low Fuel Indicator	339
Low Speed Braking Control	291
Lower Anchors	23
Luggage (Maximum Load Limit)	97

**M**

Maintenance	358
12-volt Battery	387
Brake Fluid	374
Cleaning	390
Climate Control System	389
Coolant	371
Maintenance Minder™	361
Oil	369
Radiator	373
Remote Transmitter	397
Replacing Light Bulbs	396
Safety	359
Service Items	362
Tires	378
Transmission Fluid	373
Under the Hood	366
Malfunction Indicator Lamp	338

- Map Lights ..... 168
- Maximum Load Limit ..... 97
- Meters, Gauges ..... 342
- Mirrors ..... 85
- Adjusting ..... 85
  - Door ..... 85
  - Interior Rearview ..... 85
- Modifications (and Accessories) ..... 32
- Moonroof ..... 180
- Multi View Camera System ..... 125
- ## N
- Navigation ..... 348
- Numbers (Identification) ..... 436
- ## O
- Odometer ..... 345
- Off-Highway Driving Guidelines ..... 101
- Oil (Engine) ..... 368
- Adding ..... 369
  - Checking ..... 369
  - Engine oil pressure low Warning ..... 420
  - Recommended Engine Oil ..... 368
  - Viscosity ..... 368
- Open Source Licenses ..... 271, 446
- Opening
- Tailgate ..... 429
- Opening/Closing
- Hood ..... 366
  - Moonroof ..... 180
  - Panoramic Roof ..... 181
  - Power Windows ..... 87
  - Tailgate ..... 91
- Operating the Shift Lever ..... 110
- Outside Temperature ..... 343
- Overheating ..... 418
- ## P
- Paddle Shifters (7-Speed Manual Shift Mode) ..... 111
- Panic Mode ..... 51
- Panoramic Roof ..... 181
- Parking ..... 122
- Parking Brake ..... 114
- Parking Brake and Brake System (Amber) ..... 338
- Parking Brake and Brake System (Red) ..... 337
- Parking Sensor System ..... 330
- Passenger Airbag Off Indicator ..... 44
- Playing *Bluetooth*® Audio ..... 205
- Power Tailgate ..... 91
- Power Windows ..... 87
- Precautions While Driving
- Rain ..... 19
- Pregnant Women ..... 81
- Puncture (Tire) ..... 399
- ## R
- Radiator ..... 373
- Radio (AM/FM) ..... 201, 225
- Radio Data System (RDS) ..... 201, 226
- Range ..... 346
- RDS (Radio Data System) ..... 201, 226
- Readiness Codes (Emissions Testing) ..... 440
- Rear Defogger/Heated Door Mirror Button ..... 149
- Rear Seat Reminder ..... 76
- Rear Seats (Folding Down) ..... 73
- Rear View Camera ..... 123
- Rearview Mirror ..... 85
- Refueling ..... 133
- Fuel Gauge ..... 343
  - Gasoline ..... 133, 434
  - Low Fuel Indicator ..... 339
- Regulations ..... 163, 382, 437
- Remote Engine Start ..... 106
- Remote Transmitter ..... 54
- Replacement
- 12-volt Battery ..... 387
  - Bulbs ..... 396
  - Fuses ..... 421
  - Tires ..... 378, 407
  - Wiper Blade Rubber ..... 376
- Reporting Safety Defects ..... 438
- Resetting a Trip Meter ..... 347
- Road Departure Mitigation System ..... 296
- On and Off ..... 297
- ## S
- Safe Driving ..... 14
- Safety Check ..... 17
- Safety Labels ..... 47
- Safety Message ..... 1
- Safety Support ..... 350
- Indicator (Amber) ..... 341
  - Indicator (Green/Gray) ..... 351
- Seat Belts ..... 77, 350
- Adjusting the Shoulder Anchor ..... 82

Automatic Seat Belt Tensioners	79
Checking	83
Detachable Anchor	82
Fastening	80
Installing a Child Seat with a Lap/Shoulder Seat Belt	25
Pregnant Women	81
Reminder	78
Warning Indicator	78, 338
Seat Heaters	177
Seats	68
Adjusting	68
Front Seats	70
Rear Seats	72
Seat Heaters	177
Ventilation	177
Security System	50
Immobilizer System Indicator	49
Security System Alarm Indicator	50
Selecting a Child Seat	22
Settings	352
Shift Lever	110
Releasing	417
Won't Move	417
Shift Position Indicator	110
Shifting (Transmission)	110
Shoulder Anchor	82
Side Airbags	40
Side Curtain Airbags	42
Snow Tires	385
Sonar Sensors	281
Spare Tire	407, 435
Spark Plugs	434
Specifications	434
Specified Fuel	133, 434
Speed/Distance Units	354
Speedometer	342
SRS Airbags (Airbags)	35
Starting Assist Brake Function	158
Starting the Engine	105
Does Not Start	412
If the Battery Is Dead	415
Steering Wheel	67
Adjusting	67
Heater	179
Stopping	106
Sunglasses Holder	174
Supplemental Restraint System (SRS)	35

Switches (Around the Steering Wheel)	11, 12
System Message Indicator	355
System Updates	220

## T

Tachometer	343
Tailgate	90
Opening/Closing	90
Unable to Open	429
Temperature	
Gauge	343
Outside Temperature	343
Temperature Sensor	343
Temporary Tire Repair Kit	400
Tie-down Anchors	173
Tire Pressure Monitoring System (TPMS) with Tire Fill Assist	162
Indicator	340
Tire Repair Kit	399
Tires	378
Air Pressure	435
Checking and Maintaining	378
Flat Tire (Puncture)	399, 407
Inspection	379
Labeling	379
Puncture (Flat Tire)	399, 407
Regulations	382
Rotation	385
Spare	407
Spare Tire	435
Temporary Tire Repair Kit	400
Tire Chains	385
Wear Indicators	384
Winter	385
Tools	394
Towing a Trailer	100
Load Limits	97
Towing Behind a Motorhome	100
Towing Your Vehicle	100
Behind a Motorhome	100
Emergency	427
TPMS (Tire Pressure Monitoring System) with Tire Fill Assist	162
Indicator	340
Traffic Jam Assist	314
Traffic Sign Recognition System	319, 344
Transmission	110
7-Speed Manual Shift Mode	111

- Continuously Variable Transmission ..... 110
  - Fluid ..... 373
  - Indicator ..... 340
  - Number ..... 436
  - Shift Position Indicator ..... 110
  - Trip Meter** ..... 347
  - Troubleshooting**
    - Blown Fuse ..... 421
    - Emergency Towing ..... 427
    - Engine Won't Start ..... 412
    - Flat Tire/Puncture ..... 399
    - Overheating ..... 418
    - Premium Gasoline ..... 133
    - Puncture/Flat Tire ..... 399, 407
    - Rear Door Won't Open ..... 65
    - Shift Lever Won't Move ..... 417
    - Warning Indicators ..... 335
  - Turbo Engine Vehicle** ..... 137
  - Turn Signals** ..... 138
    - Indicators (Instrument Panel) ..... 138
  - Two-way Keyless Remote** ..... 62
- U**
- Under-Floor Storage Area ..... 176
  - Unlocking the Doors ..... 54
  - USB Flash Drives ..... 204, 228, 259
  - USB Ports ..... 192
- V**
- Vanity Mirrors ..... 9
  - Vehicle Identification Number ..... 436
  - Vehicle Settings ..... 352
  - Vehicle Stability Assist™ (VSA®) ..... 160
    - Off Indicator ..... 339
    - OFF Button ..... 161
    - System Indicator ..... 339
  - Viscosity (Oil) ..... 368, 435
  - VSA® (Vehicle Stability Assist™) ..... 160
- W**
- Walk Away Auto Lock® ..... 58
  - Warning ..... 355
  - Warning Indicator On/Blinking ..... 337
  - Warning Labels ..... 47
  - Warranties (Warranty Manual provided separately) ..... 441
  - Watts ..... 434
  - Wear Indicators (Tire) ..... 384
  - Wheel Nut Wrench (Jack Handle) ..... 409
  - Wi-Fi Connection ..... 232
  - Window Washers**
    - Adding/Refilling Fluid ..... 374
    - Switch ..... 145
  - Windows (Opening and Closing)** ..... 87
  - Windshield**
    - Cleaning ..... 390, 392
    - Defrosting/Defogging ..... 149
    - Washer Fluid ..... 374
    - Wiper Blades ..... 376
    - Wipers and Washers ..... 145
  - Winter Tires**
    - Snow Tires ..... 385
    - Tire Chains ..... 385
  - Wipers and Washers** ..... 145
    - Automatic Intermittent Wipers ..... 147
    - Checking and Replacing Wiper Blades ..... 376
    - Front ..... 145
    - Rear ..... 147
  - Wired Connection** ..... 203, 227
  - Wireless Charger** ..... 170
  - Worn Tires** ..... 378



MYGARAGE.ACURA.COM (U.S.A.)  
ACURA.CA (CANADA)

313BH600  
OM-27360  
00X31-3BH-6001

2025 ACURA ADX OWNER'S MANUAL  
©2025 HONDA MOTOR CO., LTD. — ALL RIGHTS RESERVED

PRINTED IN THE U.S.A.