

FORD **EXPEDITION** Owner's Manual

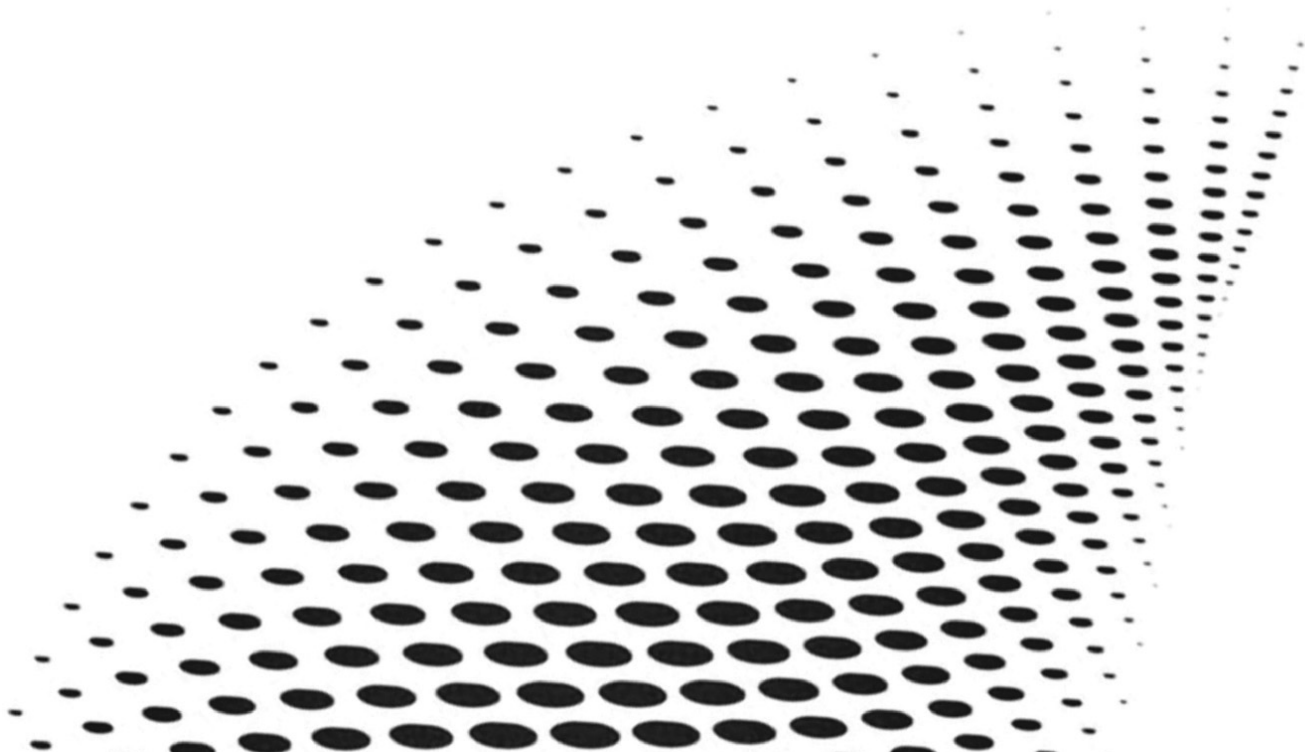

The information contained in this publication was correct at the time of release. In the interest of continuous development, we reserve the right to change specifications, design or equipment at any time without notice or obligation. No part of this publication may be reproduced, transmitted, stored in a retrieval system or translated into any language in any form by any means without our written permission. Errors and omissions excepted.

© Ford Motor Company 2024

All rights reserved.

Part Number: -202406-20240624195352

California Proposition 65



WARNING: Operating, servicing and maintaining a passenger vehicle or off-highway motor vehicle can expose you to chemicals including engine exhaust, carbon monoxide, phthalates, and lead, which are known to the State of California to cause cancer and birth defects or other reproductive harm. To minimize exposure, avoid breathing exhaust, do not idle the engine except as necessary, service your vehicle in a well-ventilated area and wear gloves or wash your hands frequently when servicing your vehicle. For more information go to www.P65Warnings.ca.gov/passenger-vehicle.



WARNING: Battery posts, terminals and related accessories contain lead and lead compounds, chemicals known to the State of California to cause cancer and reproductive harm. **Wash your hands after handling.**

Table of Contents

Contacting Us

Contacting Us15

Introduction

About This Publication17

Using This Publication18

Symbols Glossary

Symbols Used on Your Vehicle19

Symbols Used On Your Instrument Cluster
.....21

Data Privacy

Data Privacy24

Service Data25

Event Data25

Settings Data26

Connected Vehicle Data26

Mobile Device Data27

Emergency Call System Data27

Environment

Protecting the Environment28

Visual Search

Interior Overview29

Exterior Overview31

Child Safety

Child Safety Precautions33

Child Restraint Anchor Points34

Child Restraints35

Installing Child Restraints38

Booster Seats41

Child Safety Locks44

Seatbelts

Seatbelt Precautions45

Fastening and Unfastening the Seatbelts
.....46

Sensitive Locking Mode47

Automatic Locking Mode47

Adjusting the Seatbelts During Pregnancy
.....48

Adjusting the Seatbelt Height48

Seatbelt Reminder49

Checking the Seatbelts50

Seatbelt Extensions51

Personal Safety System™

What Is the Personal Safety System52

How Does the Personal Safety System
Work52

Personal Safety System Components52

Airbags

How Do the Front Airbags Work53

How Do the Side Airbags Work53

How Does the Safety Canopy™ Work54

Airbag Precautions55

Properly Adjusting the Driver and Front
Passenger Seats56

Children and Airbags56

Front Passenger Sensing System57

Crash Sensors and Airbag Indicator60

Disposing of Airbags61

911 Assist - Vehicles With: Emergency Assistance

What Is 911 Assist62

How Does 911 Assist Work62

Emergency Call Requirements62

Emergency Call Limitations63

Keys and Remote Controls

Remote Control Limitations64

Using the Remote Control64

Removing the Key Blade65

Sounding the Panic Alarm65

Table of Contents

Locating Your Vehicle	65
Changing the Remote Control Battery	65
Replacing a Lost Key or Remote Control	66
Programming the Remote Control	66
Keys and Remote Controls Audible Warnings	67
Keys and Remote Controls – Troubleshooting	68
Phone as a Key	
What Is Phone as a Key	69
Phone as a Key Limitations	69
Programming Your Phone	69
Using the Valet Mode	69
Using the Backup Start Passcode	70
Phone as a Key – Troubleshooting	71
Doors and Locks	
Operating the Doors From Outside Your Vehicle	73
Operating the Doors From Inside Your Vehicle	73
Autounlock	74
Autolock	74
Mislock	74
Doors and Locks Audible Warnings	75

Doors and Locks – Troubleshooting	75
---	----

Keyless Entry

What Is Keyless Entry	76
Keyless Entry Limitations	76
Keyless Entry Settings	76
Using Keyless Entry	76
Keyless Entry – Troubleshooting	77

Keyless Entry Keypad

What Is the Keyless Entry Keypad	78
Keyless Entry Keypad Limitations	78
Locating the Keyless Entry Keypad	78
Keyless Entry Keypad Master Access Code	78
Keyless Entry Keypad Personal Access Codes	79
Using the Keyless Entry Keypad	80
Keyless Entry Keypad – Troubleshooting	80

Easy Entry and Exit

How Does Easy Entry and Exit Work	81
Switching Easy Entry and Exit On and Off	81

Splitgate

Opening and Closing the Splitgate	82
Opening the Open on Approach Splitgate	83
Open on Approach Settings	84
Splitgate Settings	84
Opening and Closing the Liftgate	84
Liftgate Settings	86
Opening and Closing the Tailgate	87
Tailgate Settings	87
Splitgate – Troubleshooting	87

Security

Passive Anti-Theft System	90
Anti-Theft Alarm System	90
Security – Troubleshooting	91

Power Running Boards

Power Running Board Precautions	93
Power Running Board Settings	93
Power Running Boards – Troubleshooting	94

Steering Wheel

Using the Controls on the Steering Wheel	95
--	----

Table of Contents

Adjusting the Steering Wheel - Vehicles With: Manual Adjustable Steering Column	96
Adjusting the Steering Wheel - Vehicles With: Power Adjustable Steering Column	96
Resetting the Stopping Position - Vehicles With: Power Adjustable Steering Column	97
Horn	97
Switching the Heated Steering Wheel On and Off - Vehicles With: Heated Steering Wheel	97

Adjustable Pedals

Adjusting the Pedals	98
----------------------------	----

Wipers and Washers

Wipers	99
Autowipers	99
Switching the Rear Window Wiper On and Off	100
Reverse Wipe	100
Checking the Wiper Blades	100
Replacing the Front Wiper Blades	100
Replacing the Rear Wiper Blades	101
Washers	102

Wipers and Washers – Troubleshooting	104
--	-----

Exterior Lighting

Exterior Lighting Control	105
Headlamps	105
Headlamps – Troubleshooting	106
Autolamps	106
Exterior Lamps	107
Exterior Zone Lighting	109
Automatic High Beam Control	110
Automatic High Beam Control – Troubleshooting	113

Interior Lighting

Switching All of the Interior Lamps On and Off	114
Switching the Front Interior Lamps On and Off	114
Switching the Rear Interior Lamps On and Off	114
Interior Lamp Function	114
Adjusting the Instrument Panel Lighting Brightness	115
Ambient Lighting	115
Interior Lighting – Troubleshooting	115

Windows

Opening and Closing the Windows	116
Global Opening and Closing	116
Window Bounce-Back	117
Locking the Rear Window Controls	118

Interior Mirror

Interior Mirror Precautions	119
Manually Dimming the Interior Mirror	119
Auto-Dimming Interior Mirror	119

Exterior Mirrors

Adjusting the Exterior Mirrors	120
Folding the Exterior Mirrors - Vehicles With: Manual Folding Mirrors	120
Folding the Exterior Mirrors - Vehicles With: Power Folding Mirrors	121
Auto-Dimming Exterior Mirror	121

Glass Roof

Opening and Closing the Sunshade	122
Opening and Closing the Glass Roof	122
Venting the Glass Roof	123
Glass Roof Bounce-Back	123

Table of Contents

Instrument Cluster

Instrument Cluster Overview	124
Tachometer	125
Speedometer	125
Fuel Gauge	125
Engine Coolant Temperature Gauge	125

Trip Computer

Accessing the Trip Computer	126
Resetting the Trip Computer	126

Remote Start

Using Remote Start - Vehicles With: Ford Mobile App/Phone as a Key	127
Using Remote Start - Vehicles With: Remote Control	127
Remote Start Settings	128

Climate Control

Identifying the Climate Control Unit	129
Switching Climate Control On and Off	129
Switching Recirculated Air On and Off	129
Switching Air Conditioning On and Off	129
Switching Defrost On and Off	129

Switching Maximum Defrost On and Off	129
Switching Maximum Cooling On and Off	130
Switching the Heated Rear Window On and Off	130
Setting the Blower Motor Speed	130
Switching the Heated Mirrors On and Off	130
Setting the Temperature	130
Directing the Flow of Air	131
Locking the Rear Passenger Climate Controls	131
Auto Mode	131
Climate Control Hints	133
Air Conditioning System Refrigerant	134

Rear Passenger Climate Control

Identifying the Rear Passenger Climate Control Unit	135
Switching the Rear Passenger Climate Controls On and Off	135
Setting the Blower Motor Speed	135
Setting the Temperature	135
Directing the Flow of Air	135
Rear Auto Mode	136

Rear Passenger Climate Control Indicators	136
--	-----

Interior Air Quality

What Is the Cabin Air Filter	137
Replacing the Cabin Air Filter	137

Front Seats

Front Seat Precautions	138
Sitting in the Correct Position	138
Manual Seats	139
Power Seats	141
Massage Seats	144
Heated Seats	145
Ventilated Seats	146

Rear Seats

Manual Seats	147
Power Seats	152
Heated Seats	155

Rear Occupant Alert System

What is the Rear Occupant Alert System	157
How Does the Rear Occupant Alert System Work	157

Table of Contents

Rear Occupant Alert System Precautions	157
Rear Occupant Alert System Limitations	157
Rear Occupant Alert System Settings	158
Rear Occupant Alert System Indicators	158
Rear Occupant Alert System Audible Warnings	159

Garage Door Opener

Garage Door Opener Introduction	160
Garage Door Opener Precautions and Frequencies	160
Programming the Garage Door Opener	161

USB Ports

Locating the USB Ports	164
Playing Media Using the USB Port	164
Charging a Device	164

Power Outlet - Vehicles With: 110-120V Power Outlet/120V Power Outlet

What Is the Power Outlet	166
Power Outlet Precautions	166
Power Outlet Limitations	166

Locating the Power Outlets	166
Power Outlet Indicators	167

Power Outlet - Vehicles With: 12V Power Outlet

What Is the Power Outlet	168
Power Outlet Precautions	168
Locating the Power Outlets	168

Wireless Accessory Charger

What Is the Wireless Accessory Charger	169
Wireless Accessory Charger Precautions	169
Locating the Wireless Accessory Charger	169
Charging a Wireless Device	169

Storage

Overhead Storage	171
Glove Compartment	171
Center Console	171
Under Floor Storage	172

Starting and Stopping the Engine

Starting and Stopping the Engine – Precautions	173
Push Button Ignition Switch	173
Starting the Engine	174
Engine Block Heater	174
Stopping the Engine	175
Automatic Engine Stop	176
Accessing the Passive Key Backup Position	176
Starting and Stopping the Engine – Troubleshooting	178

Auto-Start-Stop

What Is Auto-Start-Stop	181
Auto-Start-Stop Precautions	181
Switching Auto-Start-Stop On and Off	181
Stopping the Engine	181
Restarting the Engine	181
Auto-Start-Stop Indicators	181
Auto-Start-Stop – Troubleshooting	182

Fuel and Refueling

Fuel and Refueling Precautions	184
Fuel Quality	184

Table of Contents

Locating the Fuel Filler Funnel	185	Four-Wheel Drive Precautions	198	Electronic Locking Differential Indicators	211
Running Out of Fuel	185	Four-Wheel Drive Limitations	199	Electronic Locking Differential – Troubleshooting	211
Refueling	187	Selecting a Four-Wheel Drive Mode	199	Brakes	
Fuel Tank Capacity	188	Four-Wheel Drive Modes	200	Brake Precautions	212
Fuel and Refueling – Troubleshooting	189	Four-Wheel Drive Indicators	201	Anti-Lock Braking System	212
Catalytic Converter		Transfer Case Fluid Capacity and Specification	201	Brake Over Accelerator	212
What Is the Catalytic Converter	190	Four-Wheel Drive – Troubleshooting	202	Locating the Brake Fluid Reservoir	212
Catalytic Converter Precautions	190	Front Axle		Checking the Brake Fluid	212
Catalytic Converter – Troubleshooting	190	Front Axle Fluid Capacity and Specification	205	Brake Fluid Specification	213
Automatic Transmission		Rear Axle		Brakes – Troubleshooting	214
Automatic Transmission Positions	192	Rear Axle Fluid Capacity and Specification	206	Electric Parking Brake	
Manually Shifting Gears	193	Electronic Locking Differential		What Is the Electric Parking Brake	216
Temporary Neutral Mode	194	What Is the Electronic Locking Differential	209	Applying the Electric Parking Brake	216
Automatic Return to Park (P)	195	How Does the Electronic Locking Differential Work	209	Applying the Electric Parking Brake in an Emergency	216
Shifting Your Immobile Vehicle Out of Park (P)	195	Electronic Locking Differential Precautions	209	Manually Releasing the Electric Parking Brake	216
Automatic Transmission Audible Warnings	196	Switching the Electronic Locking Differential On and Off	209	Automatically Releasing the Electric Parking Brake	217
Using Progressive Range Selection	196			Electric Parking Brake Audible Warning	217
Automatic Transmission Fluid Capacity and Specification	196			Releasing the Electric Parking Brake if the Vehicle Battery Has Run Out of Charge	217
Four-Wheel Drive					
How Does Four-Wheel Drive Work	198				

Table of Contents

Electric Parking Brake – Troubleshooting	217
--	-----

Reverse Brake Assist

What Is Reverse Brake Assist	219
How Does Reverse Brake Assist Work	219
Reverse Brake Assist Precautions	219
Switching Reverse Brake Assist On and Off	220
Overriding Reverse Brake Assist	220
Reverse Brake Assist Indicators	220
Reverse Brake Assist – Troubleshooting	221

Hill Start Assist

What Is Hill Start Assist	223
How Does Hill Start Assist Work	223
Hill Start Assist Precautions	223
Hill Start Assist – Troubleshooting	223

Auto Hold

How Does Auto Hold Work	224
Switching Auto Hold On and Off	224
Using Auto Hold	224
Auto Hold Indicators	224

Traction Control

What Is Traction Control	225
How Does Traction Control Work	225
Switching Traction Control On and Off	225
Traction Control Indicator	225
Traction Control – Troubleshooting	226

Stability Control

How Does Stability Control Work	227
Switching Stability Control On and Off	228
Stability Control Indicator	230

Trail Control

What Is Trail Control	231
Switching Trail Control On and Off	231
Setting the Trail Control Speed	231
Canceling the Set Speed	231
Trail Control Indicators	231
Trail One Pedal Drive	232
Trail One Pedal Drive – Troubleshooting	233
Trail Control – Troubleshooting	234

Trail Turn Assist

What Is Trail Turn Assist	236
Trail Turn Assist Precautions	236
Trail Turn Assist Limitations	236
Switching Trail Turn Assist On and Off	236
Trail Turn Assist Indicators	236
Trail Turn Assist – Troubleshooting	237

Hill Descent Control

What Is Hill Descent Control	238
How Does Hill Descent Control Work	238
Hill Descent Control Precautions	238
Switching Hill Descent Control On and Off	238
Setting the Hill Descent Speed	238
Hill Descent Control Indicator	238
Hill Descent Control – Troubleshooting	239

Steering

Electric Power Steering	240
Steering – Troubleshooting	240

Parking Aids

Parking Aid Precautions	243
-------------------------------	-----

Table of Contents

Switching Parking Aid On and Off	243
Rear Parking Aid	244
Front Parking Aid	244
Parking Aid Indicators	246
Parking Aids – Troubleshooting	247

Rear View Camera

What Is the Rear View Camera	248
Rear View Camera Precautions	248
Locating the Rear View Camera	248
Rear View Camera Guide Lines	249
Rear View Camera Settings	249

360 Degree Camera

What Is the 360 Degree Camera	251
How Does the 360 Degree Camera Work	251
360 Degree Camera Precautions	251
360 Degree Camera Limitations	251
Locating the 360 Degree Cameras	251
360 Degree Camera Guide Lines	252
360 Degree Camera Settings	253

Adaptive Cruise Control

How Does Adaptive Cruise Control With Stop and Go Work	255
--	-----

Adaptive Cruise Control Precautions	255
Adaptive Cruise Control Limitations	256
Switching Adaptive Cruise Control On and Off	258
Adaptive Cruise Control Automatic Cancellation	259
Setting the Adaptive Cruise Control Speed	259
Setting the Adaptive Cruise Control Gap	260
Canceling the Set Speed	261
Resuming the Set Speed	261
Overriding the Set Speed	262
Adaptive Cruise Control Indicators	263
Switching From Adaptive Cruise Control to Cruise Control	263
Lane Centering	263
Lane Centering – Troubleshooting	266
Predictive Speed Assist	267
Predictive Speed Assist – Troubleshooting	269
Adaptive Cruise Control – Troubleshooting	270

BlueCruise

What Is BlueCruise	271
How Does BlueCruise Work	271
BlueCruise Precautions	271

BlueCruise Requirements	272
BlueCruise Limitations	273
BlueCruise Settings	273
Switching BlueCruise On and Off	273
BlueCruise Alerts	274
BlueCruise Automatic Cancellation	274
BlueCruise Indicators	275
Lane Change Assist	276
Lane Change Assist – Troubleshooting	277
In-Lane Repositioning	277
BlueCruise – Troubleshooting	278

Drive Mode Control

What Is Drive Mode Control	280
How Does Drive Mode Control Work	280
Selecting a Drive Mode - 4x2	280
Selecting a Drive Mode - 4x4	280
Drive Modes	281
Drive Mode Control – Troubleshooting	283

Lane Keeping System

What Is the Lane Keeping System	286
How Does the Lane Keeping System Work	286
Lane Keeping System Precautions	286

Table of Contents

Lane Keeping System Limitations	286
Switching the Lane Keeping System On and Off	287
Switching the Lane Keeping System Mode	287
Lane Keeping System Settings	287
Alert Mode	288
Aid Mode	288
Alert and Aid Mode	288
Lane Keeping System Indicators	289
Blind Spot Assist	290
Blind Spot Assist with Trailer Coverage	290
Lane Keeping System – Troubleshooting	294

Blind Spot Information System

What Is Blind Spot Information System	296
How Does Blind Spot Information System Work	296
Blind Spot Information System Precautions	296
Blind Spot Information System Limitations	296
Blind Spot Information System Requirements	297

Switching Blind Spot Information System On and Off	297
Locating the Blind Spot Information System Sensors	297
Blind Spot Information System With Trailer Coverage	297
Blind Spot Information System Indicators	299
Blind Spot Information System – Troubleshooting	300

Exit Warning

What is Exit Warning	301
How Does Exit Warning Work	301
Exit Warning Precautions	301
Exit Warning Limitations	302
Exit Warning Indicators	302
Switching Exit Warning On and Off	302
Locating the Exit Warning Sensors	303
Exit Warning – Troubleshooting	303

Cross Traffic Alert

What Is Cross Traffic Alert	304
How Does Cross Traffic Alert Work	304
Cross Traffic Alert Precautions	304
Cross Traffic Alert Limitations	305

Switching Cross Traffic Alert On and Off	306
Locating the Cross Traffic Alert Sensors	306
Cross Traffic Alert Indicators	306
Cross Traffic Alert – Troubleshooting	307

Pre-Collision Assist

What Is Pre-Collision Assist	308
How Does Pre-Collision Assist Work	308
Pre-Collision Assist Precautions	308
Pre-Collision Assist Limitations	309
Switching Pre-Collision Assist On and Off	311
Locating the Pre-Collision Assist Sensors	312
Forward Collision Warning	312
Automatic Emergency Braking	313
Evasive Steering Assist	313
Pre-Collision Assist – Troubleshooting	314

Speed Sign Recognition

What Is Speed Sign Recognition	316
How Does Speed Sign Recognition Work	316
Speed Sign Recognition Precautions	316

Table of Contents

Speed Sign Recognition Limitations	316
Speed Sign Recognition Indicators	317
Speed Sign Recognition Settings	317
Speed Sign Recognition – Troubleshooting	317

Driver Alert

What Is Driver Alert	319
How Does Driver Alert Work	319
Driver Alert Precautions	319
Driver Alert Limitations	319
Switching Driver Alert On and Off	320
Driver Alert Indicators	320
Driver Alert – Troubleshooting	320

Load Carrying

Load Carrying Precautions	321
Locating the Safety Compliance Certification Labels	321
What Is the Gross Axle Weight Rating	322
What Is the Gross Vehicle Weight Rating	322
What Is the Gross Combined Weight Rating	322
Calculating Payload	322
Calculating the Load Limit	323
Roof Rack	324

Luggage Compartment

Luggage Compartment Precautions	326
Installing and Removing the Luggage Compartment Cargo Net	326
Adjusting the Luggage Compartment Load Floor	327
Adjusting the Luggage Compartment Divider	328
Luggage Compartment Anchor Points	329

Connecting a Trailer

Connecting a Trailer Precautions	330
Hitches	330
Connecting a Trailer	332
Trailer Lighting Check	333
Connecting a Trailer – Troubleshooting	334

Towing a Trailer

Towing a Trailer Precautions	335
Trailer Brake Precautions	335
Towing a Trailer Limitations	336
Loading Your Trailer	336
Trailer Towing Hints	336
Launching or Retrieving a Boat or Personal Watercraft	337

Towing Weights and Dimensions	338
Towing a Trailer – Troubleshooting	340

Integrated Trailer Brake Controller

What Is the Integrated Trailer Brake Controller	342
Integrated Trailer Brake Controller Precautions	342
Using the Integrated Trailer Brake Controller	342
Adjusting the Integrated Trailer Brake Controller Mode	344
Integrated Trailer Brake Controller – Troubleshooting	345

Trailer Sway Control

How Does Trailer Sway Control Work	347
Trailer Sway Control Precautions	347
Switching Trailer Sway Control On and Off	347

Trailer Hitching Assistance

What Is Trailer Hitching Assistance	348
How Does Trailer Hitching Assistance Work	348
Trailer Hitching Assistance Precautions	348

Table of Contents

Trailer Hitching Assistance Limitations	349
Switching Trailer Hitching Assistance On and Off	349
Using Trailer Hitching Assistance	350
Trailer Hitching Assistance Indicators	351

Trailer Backup Assistance

What is Trailer Backup Assistance	352
How Does Trailer Backup Assistance Work	352
Trailer Backup Assistance Precautions	352
Setting Up the Trailer Backup Assistance for a Conventional Trailer	352
Switching Trailer Backup Assistance On and Off	355
Using the Trailer Backup Assistance Controller	355
Using the Trailer Backup Assistance Views	356
Trailer Backup Assistance – Troubleshooting	358

Trailer Reverse Guidance

What Is Trailer Reverse Guidance	362
How Does Trailer Reverse Guidance Work	362

Trailer Reverse Guidance Precautions	362
Setting Up Trailer Reverse Guidance for a Conventional Trailer	362
Switching Trailer Reverse Guidance On and Off	365
Using Trailer Reverse Guidance Views	365
Trailer Reverse Guidance – Troubleshooting	366

Driving Hints

Breaking-In	370
Driving Economically	370
Driving in Cold Weather	370
Driving Through Mud and Water	371
Driving on Hilly or Sloping Terrain	371
Driving In Sand	371
Driving Through Shallow Water	372
Floor Mats	372

Crash and Breakdown Information

Roadside Assistance	374
Switching the Hazard Flashers On and Off	375
Jump Starting the Vehicle	375
Post-Crash Alert System	377
Post-Collision Braking	378

Automatic Crash Shutoff	378
Recovery Towing	379
Transporting the Vehicle	380
Fail-Safe Cooling	380

Towing Your Vehicle

Towing Your Vehicle Precautions	382
Recreationally Towing Your Vehicle - 4x4	382
Recreationally Towing Your Vehicle - 4x2	384
Emergency Towing	384
Towing Your Vehicle – Troubleshooting	384

Fuses

Fuse Precautions	385
Under Hood Fuse Box	385
Interior Fuse Box	391
Identifying Fuse Types	395
Fuses – Troubleshooting	395

Maintenance

Maintenance Precautions	396
Opening and Closing the Hood	396
Under Hood Overview	397
Engine Oil	398

Table of Contents

Engine Air Filter	401
Coolant	402
Changing the Fuel Filter	407
Drive Belt Routing Overview	407
12V Battery	407
12V Battery – Troubleshooting	410
Adjusting the Headlamps	411
Exterior Bulbs	413
Interior Bulbs	414

Vehicle Specifications

Engine Specifications	415
Motorcraft Parts	416

Vehicle Care

Cleaning Products	417
Cleaning the Exterior	418
Cleaning the Interior	419
Repairing Minor Paint Damage	421
Waxing Your Vehicle	422

Storing Your Vehicle

Preparing Your Vehicle for Storage	423
Removing Your Vehicle From Storage	424

Wheel and Tire Information

Locating the Tire label	425
Department of Transportation Uniform Tire Quality Grades	425
Information on the Tire Sidewall	426
Glossary of Tire Terminology	431
Tire Replacement Requirements	432
Using Snow Chains	434

Tire Care

Checking the Tire Pressures	437
Inflating the Tires	437
Inspecting the Tire for Wear	438
Inspecting the Tire for Damage	439
Inspecting the Wheel Valve Stems	443
Tire Rotation	443

Tire Pressure Monitoring System

What Is the Tire Pressure Monitoring System	445
Tire Pressure Monitoring System Overview	445
Tire Pressure Monitoring System Precautions	446
Tire Pressure Monitoring System Limitations	446

Viewing the Tire Pressures	447
Resetting Tire Pressure Monitoring System	447
Tire Pressure Monitoring System – Troubleshooting	448

Changing a Road Wheel

Changing a Flat Tire	450
Wheel Nuts	456

Vehicle Identification

Vehicle Identification Number	457
-------------------------------------	-----

Connected Vehicle

What Is a Connected Vehicle	458
Connected Vehicle Requirements	458
Connected Vehicle Limitations	458
Connecting the Vehicle to a Mobile Network	458
Connecting the Vehicle to a Wi-Fi Network	458
Connected Vehicle Settings	459
Connected Vehicle – Troubleshooting	459

Vehicle Hotspot

Setting Up a Vehicle Hotspot	461
------------------------------------	-----

Table of Contents

Vehicle Hotspot Settings461

Audio System

Audio System Precautions462
Switching the Audio Unit On and Off462
Selecting the Audio Source462
Media Control Buttons462
Adjusting the Volume463
Setting a Memory Preset463
Locking the Rear Passenger Audio Controls
.....463
Adjusting the Sound Settings463
Setting the Clock and Date463
AM/FM Radio464
Digital Radio464
Satellite Radio465

Rear Passenger Audio Controls

Identifying the Rear Passenger Audio
Controls468
Switching the Rear Passenger Audio
Controls On and Off468
Selecting the Audio Source468
Playing and Pausing the Audio Source
.....468
Adjusting the Volume468

Switching Shuffle Mode On and Off468
Switching Repeat Mode On and Off468
Changing the Radio Station468

Center Display

Center Display Overview469
Status Bar469
Apps470
Controls470
Customizing the Instrument Panel Display
.....470
Settings471
Rebooting the Displays471

Voice Interaction

What is Voice Interaction472
Setting Your Default Assistant472
Alexa Built-In472
Google Assistant473

Phone

Phone Precautions475
Connecting Your Phone475
Phone Menu475
Making and Receiving a Phone Call476

Sending and Receiving a Text Message
.....477
Switching Text Message Notification On
and Off478
Switching Apple CarPlay On and Off478
Switching Android Auto™ On and Off478

Bluetooth®

Connecting a Bluetooth® Device479
Playing Media Using Bluetooth®479

Personal Profiles

How Do Personal Profiles Work480
Enabling or Disabling Personal Profiles
.....480
Creating a Personal Profile480
Using the Memory Function480
Linking or Unlinking a Personal Profile to a
Remote Control481
Linking or Unlinking a Personal Profile to a
Device481

Navigation

Connected Navigation482

Vehicle Software Updates

Vehicle Software Updates483

Table of Contents

Software Update Settings483
Software Update Indicators484

Vehicle System Reset

Performing a System Reset485

Accessories

Accessories486

Ford Protect

What Is Ford Protect488

Scheduled Maintenance

Scheduled Maintenance490
General Maintenance Information493

Customer Information

Rollover Warning498
The Better Business Bureau Auto Line
Program - United States of America
.....498
The Mediation and Arbitration Program -
Canada499
Reporting Safety Defects in the United
States499
Reporting Safety Defects in Canada500
Radio Frequency Certification Labels501

Perchlorate562
Replacement Parts Recommendation
.....562
Mobile Communications Equipment563
Emission Law - United States of America
.....563
Export Unique Options564
Warranty Information564

Appendices

Electromagnetic Compatibility567

Contacting Us

If you require assistance or clarification on policies or procedures, please contact the customer relationship center.

United States

Ford Motor Company
Customer Relationship Center
PO Box 6248
Dearborn, MI 48126
1-800-392-3673 (FORD)
TDD for the hearing impaired:
7-1-1 (where offered by your telephone service provider)
www.ford.com/help/contact/

Ford Credit - US Only

Ford Credit offers a full range of financing and lease plans to help you acquire your vehicle. If you have financed or leased your vehicle through Ford Credit, thank you for your business.

For assistance call 1-800-727-7000, or for more information about Ford Credit and access to an account manager, visit www.ford.com/finance.

Canada

Customer Relationship Centre
Ford Motor Company of Canada Limited
P.O. Box 2000
Oakville, Ontario L6J 5E4
1-800-565-3673 (FORD)
TDD for the hearing impaired:
7-1-1 (where offered by your telephone service provider)
www.ford.ca

Australia

Ford Motor Company of Australia Pty Ltd.
Customer Relationship Centre
Private Mail Bag 5
Campbellfield, Victoria, 3061
Telephone: (13 FORD) 13 3673
E-mail: foacust1@ford.com

New Zealand

Ford Motor Company
Attention: Customer Relationship Centre
Private Bag 76912
Manukau City 2241
Telephone: 0800 367 369 (FORDNZ)
E-mail: fnzcust@ford.com

China - Imported Vehicle

Customer Relationship Center
Telephone: 400-690-1886
Website: <https://www.ford.com.cn/>

China - Chang'An Ford

Customer Relationship Center
Telephone: 800-810-8168
Mobile: 400-887-7766
Website: <https://www.ford.com.cn/>

Asia Pacific Direct Markets (APDM)

E-mail: apemcrc@ford.com

Caribbean, Central America and Israel

Ford Motor Company
Ford Export Operations
Attention: Owner Relations
1555 Fairlane Drive
Fairlane Business Park #3
Allen Park, MI 48101
Fax: (313) 390-0804
Telephone: (800) 841-3673
E-mail: atnclien@ford.com

Contacting Us

U.S. Virgin Islands and Puerto Rico

Ford Motor Company
Ford Export Operations
Attention: Owner Relations
1555 Fairlane Drive
Fairlane Business Park #3
Allen Park, MI 48101
Telephone: (800) 841-3673
E-mail: atnclien@ford.com

Argentina

Telephone: 0800-888-3673

Brazil

Website: www.ford.com.br
Telephone: 0800-703-3673
E-mail: central@ford.com

North Africa

E-mail: nafcrc@ford.com

South Africa

Telephone: 0860011022
Email: fordcrc2@ford.com

Sub-Saharan Africa

E-mail: ssacrc@ford.com

Puerto Rico

Ford International Business Development,
Inc.
P.O. Box 11957
Caparra Heights Station
San Juan, PR 00922-1957
1-800-392-3673 (FORD)
Fax: (313) 390-0804
E-mail: prcac@ford.com
www.ford.com.pr

Middle East

Ford Middle East Customer Relationship
Center
P.O. Box 21740
Dubai, United Arab Emirates
Telephone: 80004441066
Toll-free number for the Kingdom of Saudi
Arabia: 8008443673
Mobily and Zain cell phone users in Saudi
Arabia: 800850078
Kuwait: 22280384
Local telephone number for Kuwait: +965 1
898900
Fax: +971 4 3327266
E-mail: menacac@ford.com
www.me.ford.com

South Korea

Customer Relationship Center
Telephone: +82-02-1600-6003
E-mail: infokr1@ford.com
Emergency Dispatch Service call:
080-300-3673

Philippines

Telephone: 02-88669408
Email: emailus@ford.com

Taiwan

Telephone: 0800-032100
705 Zhonghua Rd., Sec. 1
Zhongli District, Taoyuan, Taiwan, 32068

Thailand

Telephone: 1383
E-mail: fordthai@ford.com

Vietnam

Telephone: 1800588888
E-mail: fordvn@ford.com

Introduction

ABOUT THIS PUBLICATION



WARNING: Driving while distracted can result in loss of vehicle control, crash and injury. We strongly recommend that you use extreme caution when using any device that may take your focus off the road. Your primary responsibility is the safe operation of your vehicle. We recommend against the use of any hand-held device while driving and encourage the use of voice-operated systems when possible. Make sure you are aware of all applicable local laws that may affect the use of electronic devices while driving.



WARNING: You risk death, fire, or serious injury to yourself and others if you do not follow the instruction highlighted by the warning symbol.

Thank you for choosing Ford. We recommend that you take some time to get to know your vehicle in order to benefit from greater safety and pleasure from driving it. Use this publication, whether in-vehicle center display screen, print, in Ford mobile app or online, to familiarize yourself with the features on your vehicle.

Note: Use and operate your vehicle in line with all applicable laws and regulations.

Note: Pass on all printed owner's information when selling this vehicle.

Features and Options

This publication describes product features and options available throughout the range of available models, sometimes even before they are generally available. It could describe options that are not available on the vehicle you have purchased.

Providing Feedback

If you would like to provide feedback to the Owner's Manual team, please email us at OWNERMANUALFEEDBACK@ford.com.

You will not receive a direct email response. Your submission will be investigated and necessary changes will be made to the Owner's Manual content.

To help investigate your submission, please include the following information:

- Your vehicle model
- The country in which your vehicle was purchased
- The Owner's Manual section needing investigation

Illustrations

Note: Some of the illustrations in this publication could show features as used in different models, so could appear different to you on your vehicle.

Location of Components

This manual may qualify the location of a component as left-hand side or right-hand side. The side is determined when facing forward in the seat.

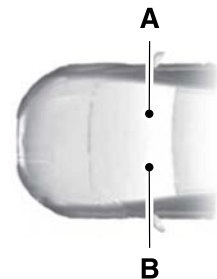

- A Right-hand side.
- B Left-hand side.

Introduction

Accessing the Digital Owner's Manual

The online version of the Owner's Manual may contain the very latest information, which may vary slightly from the in-vehicle digital Owner's Manual originally provided with your vehicle. We recommend updating the in-vehicle digital Owner's Manual when prompted using Over The Air updates.

Vehicles with a Portrait Center Display Screen

The Owner's Manual application is located in the Apps list.

Vehicles with a Landscape Center Display Screen

Depending on your vehicle, the Owner's Manual application is located in either the Apps list or the Features list.

Accessing the Online and Printed Owner's Manual

Online Owner's Manual

- Through your device's app store, you can download the Ford mobile app.
- You can visit the local Ford Website.

Note: To find the local Ford website, visit <https://corporate.ford.com/operations/locations/global-links.html>.

Note: We strongly recommend downloading a copy of the Owner's Manual and having it with you whenever you drive, and to view the information if you are unable to be inside the vehicle.

Printed Owner's Manual

In U.S. and Canada, visit www.helminc.com or see an authorized dealer.

In Europe, visit www.z-order.de or see an authorized dealer.

For all other Countries, see your authorized dealer.

USING THIS PUBLICATION

To quickly locate information about your vehicle, use the word search within the Owner's Manual application.

Symbols Glossary

SYMBOLS USED ON YOUR VEHICLE

These are some of the symbols you may see on your vehicle.



Airbag



Air conditioning system



Air conditioning system lubricant type



Anti-lock braking system



Avoid smoking, flames or sparks



Battery



Battery acid



Blower motor



Brake fluid - non petroleum based



Brake system



Brake system



Cabin air filter



Check fuel cap



Child safety door lock or unlock



Child seat lower anchor



Child seat tether anchor



Cruise control



Do not open when hot



Electric Parking brake



Engine air filter



Engine coolant



Engine coolant temperature



Engine oil



Explosive gas



Fan warning



Fasten seatbelt

































Flammable



Front fog lamps

Symbols Glossary

	Fuel pump reset		Keep out of reach of children		Passenger airbag activated
	Fuse compartment		Lighting control		Passenger airbag deactivated
	Hazard flashers		Low fuel level		Power steering fluid
	Headlamp high beams		Low tire pressure warning		Power windows front/rear
	Headlamps on		Maintain correct fluid level		Power window lockout
	Heated rear window		Malfunction Indicator Lamp (MIL)		Requires registered technician
	Hill descent control		Note operating instructions		Safety alert
	Horn control		Panic alarm		See Owner's Manual
	Interior luggage compartment release		Parking aid		See Service Manual
	Jack		Parking lamps		Side airbag

Symbols Glossary



Shield the eyes



Stability control



Stability control off



Trail control



Turn Signal



Windshield defrosting system



Windshield wiping system



Windshield wash and wipe

SYMBOLS USED ON YOUR INSTRUMENT CLUSTER

Depending on your vehicle options, market, and instrument cluster type, not all symbols shown are available.

Lighting and Signaling



High beams. See **Headlamp Indicators** (page 105).



Auto high beams. See **Automatic High Beam Control Indicators** (page 112).



Front fog lamps. See **Using the Front Fog Lamps** (page 108).



Off road auxiliary lighting active. See **Using the Off-Road Driving Lamps** (page 108).



Turn signal - right. See **Using the Turn Signal Lamps** (page 107).



Turn signal - left. See **Using the Turn Signal Lamps** (page 107).



Positioning/side lights. See **Headlamp Indicators** (page 105).



Exterior bulb failure. See **Exterior Bulb Specification Chart** (page 413).

Brakes



Brake failure. See **Brakes – Warning Lamps** (page 214).



Brake failure. See **Brakes – Warning Lamps** (page 214).



Electric parking brake fault. See **Electric Parking Brake – Warning Lamps** (page 217).



Anti-lock brake system malfunction. See **Brakes – Warning Lamps** (page 214).



Automatic brake hold. See **Auto Hold Indicators** (page 224).



Automatic brake hold off or unavailable. See **Auto Hold Indicators** (page 224).

Visibility



Windshield washer fluid level. See **Wipers and Washers – Warning Lamps** (page 104).

Symbols Glossary

Engine



Check engine. See **Coolant – Warning Lamps** (page 406).



Engine oil pressure. See **Starting and Stopping the Engine – Warning Lamps** (page 178).



Engine coolant temperature. See **Coolant – Warning Lamps** (page 406).



Auto Start/Stop. See **Auto-Start-Stop Indicators** (page 181).



Auto Start/Stop off or unavailable. See **Auto-Start-Stop Indicators** (page 181).



Vehicle maintenance.

Fuel



Fuel. See **Fuel and Refueling – Warning Lamps** (page 189).

Transmission



Non-emission powertrain fault. See **Starting and Stopping the Engine – Warning Lamps** (page 178). See **Four-Wheel Drive – Warning Lamps** (page 202).

Vehicle Handling



Selectable drive mode - normal. See **Normal** (page 281). See **Normal** (page 281).



Selectable drive mode - ECO. See **Eco** (page 281). See **Eco** (page 281).



Selectable drive mode - sport. See **Sport** (page 283). See **Sport** (page 283).



Selectable drive mode - tow/haul. See **Tow/Haul** (page 283). See **Tow/Haul** (page 283).



Selectable drive mode - slippery. See **Slippery** (page 282). See **Slippery** (page 282).



Selectable drive mode - rock crawl. See **Rock Crawl** (page 282).



Selectable drive mode - off-road. See **Off-Road** (page 281).



Steering system fault. See **Steering – Information Messages** (page 241).



Differential lock - rear axle. See **Electronic Locking Differential Indicators** (page 211).



Off road turn assist - right. See **Trail Turn Assist Indicators** (page 236).



Off road turn assist - left. See **Trail Turn Assist Indicators** (page 236).



One pedal drive. See **Trail One Pedal Drive Indicators** (page 233).



4X2. See **Four-Wheel Drive Indicators** (page 201).



4X4 auto. See **Four-Wheel Drive Indicators** (page 201).



4X4 high. See **Four-Wheel Drive Indicators** (page 201).

Symbols Glossary



4x4 low. See **Four-Wheel Drive Indicators** (page 201).

Driver Assistance



Cruise control. See **Switching From Adaptive Cruise Control to Cruise Control** (page 263).



Adaptive cruise control. See **Adaptive Cruise Control Indicators** (page 263).



Hill descent control. See **Hill Descent Control Indicator** (page 238).



Trail control. See **Trail Control Indicators** (page 231).



Lane keeping assist. See **Lane Keeping System Indicators** (page 289).



Lane keeping assist off. See **Lane Keeping System Indicators** (page 289).



Lane centering assist. See **Lane Centering Indicators** (page 266).

Safety



Seatbelt. See **Seatbelt Reminder Indicators** (page 49).



Airbag. See **Crash Sensors and Airbag Indicator** (page 60).



Stability control system active or not available. See **Stability Control Indicator** (page 230).



Stability control system off. See **Stability Control Indicator** (page 230).



Tire failure/Low tire pressure. See **Tire Pressure Monitoring System – Warning Lamps** (page 448).



Forward collision warning system off or unavailable. See **Pre-Collision Assist – Warning Lamps** (page 314).



Blind spot information system off or unavailable. See **Switching Blind Spot Information System On and Off** (page 297).



Door(s) ajar. See **Doors and Locks – Warning Lamps** (page 75).

Security



Hood release/ajar. See **Opening and Closing the Hood** (page 396).



Liftgate and tailgate release. See **Splitgate – Warning Lamps** (page 87).

Electrical Systems



Battery charge level. See **12V Battery – Warning Lamps** (page 410).

Data Privacy



WARNING: Do not connect wireless plug-in devices to the data link connector. Unauthorized third parties could gain access to vehicle data and impair the performance of safety related systems. Only allow repair facilities that follow our service and repair instructions to connect their equipment to the data link connector.

We respect your privacy and are committed to protecting it. The information contained in this publication was correct at the time of release, but as technology rapidly changes, we recommend that you visit the local Ford website for the latest information.

Your vehicle has electronic control units that have data recording functionality and the ability to permanently or temporarily store data. This data could include information on the condition and status of your vehicle, vehicle maintenance requirements, events and malfunctions. The types of data that can be recorded are described in this section. Some of the data recorded is stored in event logs or error logs.

Note: *Error logs are reset following a service or repair.*

Note: *We may provide information in response to requests from law enforcement, other government authorities and third parties acting with lawful authority or through a legal process. Such information could be used by them in legal proceedings.*

Data recorded includes, for example:

- Operating states of system components, for example fuel level, tire pressure and battery charge level.
- Vehicle and component status, for example wheel speed, deceleration, lateral acceleration and seatbelt status.
- Events or errors in essential systems, for example headlamps and brakes.
- System responses to driving situations, for example airbag deployment and stability control.
- Environmental conditions, for example temperature.

Some of this data, when used in combination with other information, for example an accident report, damage to a vehicle or eyewitness statements, could be associated with a specific person.

Services That We Provide

If you use our services, we collect and use data, for example account information, vehicle location and driving characteristics, that could identify you. We transmit this data through a dedicated, protected connection. We only collect and use data to enable your use of our services to which you have subscribed, with your consent or where permitted by law. For additional information, see the terms and conditions of the services to which you have subscribed.

For additional information about our privacy policy, refer to the local Ford website.

Services That Third Parties Provide

We recommend that you review the terms and conditions and data privacy information for any services equipped with your vehicle or to which you subscribe. We take no responsibility for services that third parties provide.

Where equipped, SiriusXM with 360L could use the modem. To disable, turn off the SiriusXM with 360L or Vehicle Connectivity setting. See **Enabling and Disabling the Modem** (page 458).

Data Privacy

Note: *Consistent with your data and connectivity settings, data may be accessed by third parties.*

SERVICE DATA

Service data recorders in your vehicle are capable of collecting and storing diagnostic information about your vehicle. This potentially includes information about the performance or status of various systems and modules in the vehicle, such as engine, throttle, steering or brake systems. In order to properly diagnose and service your vehicle, Ford Motor Company (Ford of Canada in Canada), and service and repair facilities may access or share among them vehicle diagnostic information received through a direct connection to your vehicle when diagnosing or servicing your vehicle. Additionally, Ford Motor Company (Ford of Canada, in Canada) may, where permitted by law, use vehicle diagnostic information for vehicle improvement or with other information we may have about you, for example, your contact information, to offer you products or services that may interest you. Data may be provided to our service providers such as part suppliers that may help diagnose malfunctions, and who are similarly obligated to protect data. We retain

this data only as long as necessary to perform these functions or to comply with law. We may provide information where required in response to official requests to law enforcement or other government authorities or third parties acting with lawful authority or court order, and such information may be used in legal proceedings. For U.S. only (if equipped), if you choose to use connected apps and services, you consent that certain diagnostic information may also be accessed electronically by Ford Motor Company and Ford authorized service facilities, and that the diagnostic information may be used to provide services to you, personalizing your experience, troubleshoot, and to improve products and services and offer you products and services that may interest you, where permitted by law. For Canada only, for more information, please review the Ford of Canada privacy policy at www.ford.ca, including our U.S. data storage and use of service providers in other jurisdictions who may be subject to legal requirements in Canada, the United States and other countries applicable to them, for example, lawful requirements to disclose personal information to governmental authorities in those countries.

EVENT DATA

This vehicle is equipped with an event data recorder. The main purpose of an event data recorder is to record, in certain crash or near crash-like situations, such as an airbag deployment or hitting a road obstacle; this data will assist in understanding how a vehicle's systems performed. The event data recorder is designed to record data related to vehicle dynamics and safety systems for a short period of time, typically 30 seconds or less.

The event data recorder in this vehicle is designed to record such data as:

- How various systems in your vehicle were operating.
- Whether or not the driver and passenger seatbelts were buckled/fastened.
- How far (if at all) the driver was depressing the accelerator and/or the brake pedal.
- How fast the vehicle was traveling.
- Where the driver was positioning the steering wheel.

This data can help provide a better understanding of the circumstances in which crashes and injuries occur.

Data Privacy

Note: *Event data recorder data is recorded by your vehicle only if a non-trivial crash situation occurs; no data is recorded by the event data recorder under normal driving conditions and no personal data or information (for example name, gender, age, and crash location) is recorded. However, parties, such as law enforcement, could combine the event data recorder data with the type of personally identifying data routinely acquired during a crash investigation.*

To read data recorded by an event data recorder, special equipment is required, and access to the vehicle or the event data recorder is needed. In addition to the vehicle manufacturer, other parties, such as law enforcement, that have such special equipment, can read the information if they have access to the vehicle or the event data recorder.

BlueCruise Data (If Equipped)

If BlueCruise is active in certain crash or near crash-like situations, such as an airbag deployment or hitting a road obstacle, the system may record driver attentiveness, based on the direction of eyes and duration, and photographs of the driver seat area.

Note: *No data is recorded under normal driving conditions.*

SETTINGS DATA

Your vehicle has electronic control units that have the ability to store data based on your personalized settings. The data is stored locally in the vehicle or on devices that you connect to it, for example, a USB drive or mobile device. You can delete some of this data and also choose whether to share it through the services to which you subscribe. See **Settings** (page 471).

Comfort and Convenience Data

Data recorded includes, for example:

- Seat and steering wheel position.
- Climate control settings.
- Radio presets.

Entertainment Data

Data recorded includes, for example:

- Music, videos or album art.
- Contacts and corresponding address book entries.
- Navigation destinations.

CONNECTED VEHICLE DATA

The modem has a SIM. The modem was enabled when your vehicle was built and periodically sends messages to stay connected to the cell phone network, receive automatic software updates and send vehicle-related information to us, for example diagnostic information. These messages could include information that identifies your vehicle, the SIM and the electronic serial number of the modem. Cell phone network service providers could have access to additional information, for example cell phone network tower identification. For additional information about our privacy policy, visit www.FordConnected.com or refer to your local Ford website.

Note: *The modem may continue to send this information unless you disable the modem or stop the modem from sharing vehicle data by changing the connectivity settings. See **Connected Vehicle** (page 458).*

Note: *The service can be unavailable or interrupted for a number of reasons, for example environmental or topographical conditions and data plan coverage.*

Note: *To find out if your vehicle has connectivity technology, visit www.FordConnected.com.*

Data Privacy

MOBILE DEVICE DATA

If you connect a mobile device to your vehicle, you can display data from your device on the touchscreen for example, music and album art. You can grant apps permission to access your connected vehicle information with mobile apps on your device through the system.

The mobile apps function operates by your connected device sending data to us in the United States. The data is encrypted and includes, for example, the vehicle identification number of your vehicle, the operating system module serial number, odometer, enabled apps, usage statistics and debugging information. We retain it only as long as necessary to provide the service, to troubleshoot, for continuous improvement and to offer you products and services that may be of interest to you according to your preferences and where allowed by law.

If you connect a cell phone to the system, the system creates a profile that links to that cell phone. The cell phone profile enables more mobile features and efficient operation. The profile contains, for example data from your phonebook, read and unread text messages and call history, including history of calls when your cell phone was not connected to the system.

If you connect a media device, the system creates and retains a media device index of supported media content. The system also records a short diagnostic log of approximately 10 minutes of all recent system activity.

The cell phone profile, media device index and diagnostic log remain in your vehicle unless you delete them and are generally accessible only in your vehicle when you connect your cell phone or media device. If you no longer plan to use the system or your vehicle, we recommend you use the applicable reset function to erase the stored information. See **Performing a System Reset** (page 485).

System data cannot be accessed without special equipment and access to your vehicle's module.

For additional information about our privacy policy, refer to the local Ford website.

Note: To find out if your vehicle has connectivity technology, visit www.FordConnected.com.

EMERGENCY CALL SYSTEM DATA

When the emergency call system is active, it may disclose to emergency services that your vehicle has been in a crash involving the deployment of an airbag or activation of the fuel pump shut-off. Certain versions or updates to the emergency call system may also be capable of electronically or verbally disclosing to emergency services operators your vehicle location or other details about your vehicle or crash to assist emergency services operators to provide the most appropriate emergency services. If you do not want to disclose this information, do not activate the emergency call system.

Note: You cannot deactivate emergency call systems that are required by law.

Environment

PROTECTING THE ENVIRONMENT

Sustainability is a priority at Ford. We are constantly looking for ways to reduce our impact on the planet while providing customers with great products and delivering a strong business. You should play your part in protecting the environment. Correct vehicle usage and the authorized disposal of waste, cleaning and lubrication materials are significant steps toward this aim.

For additional information about our sustainability progress and initiatives, visit www.sustainability.ford.com.

Visual Search

INTERIOR OVERVIEW

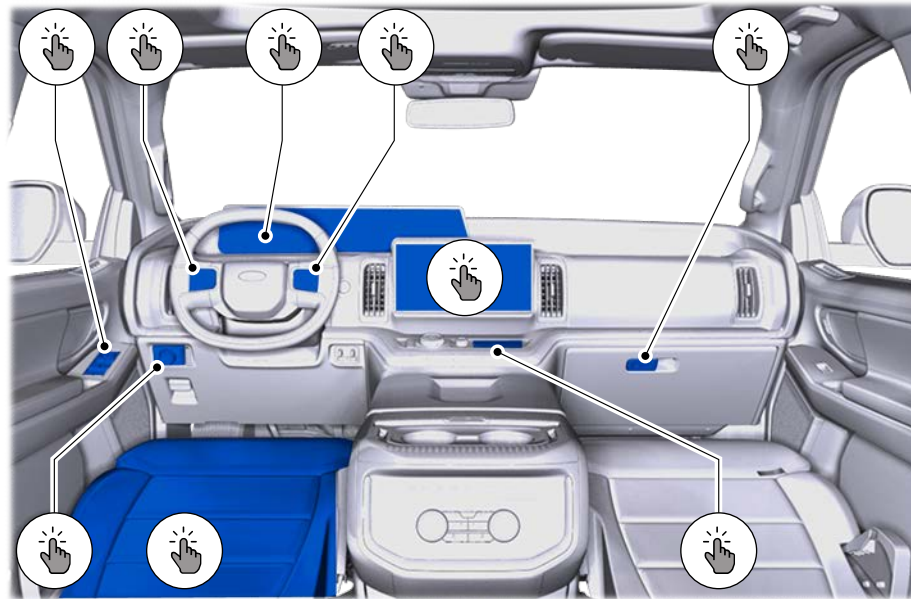

Visual Search

- A See **Adjusting the Exterior Mirrors** (page 120).
- B See **Switching Adaptive Cruise Control On and Off** (page 258).
- C See **Instrument Cluster Overview** (page 124).
- D See **Using the Controls on the Steering Wheel** (page 95).
- E See **Opening the Glove Compartment** (page 171).
- F See **Center Display Overview** (page 469).
- G See **Switching the Hazard Flashers On and Off** (page 375).
- H See **Sitting in the Correct Position** (page 138).
- I See **Selecting a Drive Mode** (page 280).

Visual Search

EXTERIOR OVERVIEW

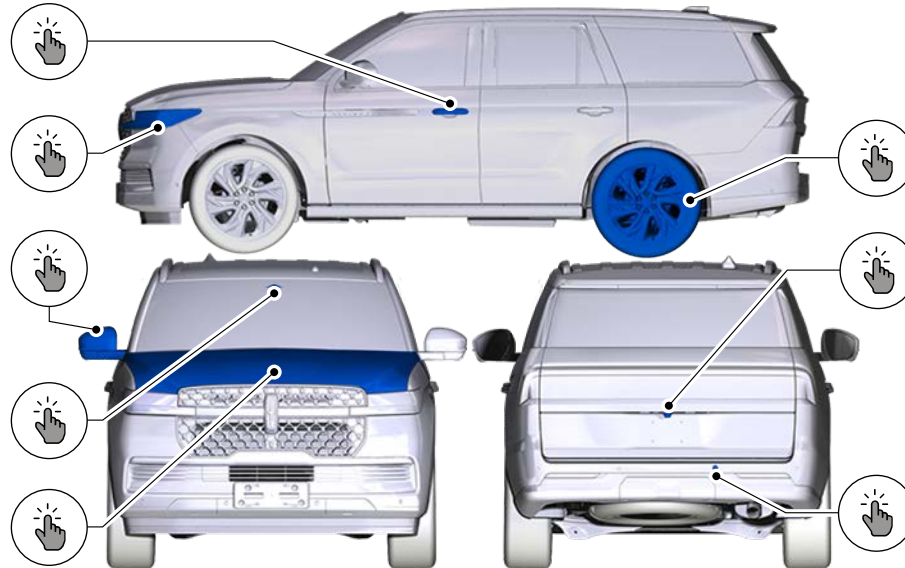

Visual Search

- A See **Unlocking and Locking the Doors Using the Remote Control** (page 73).
- B See **Changing a Flat Tire** (page 450).
- C See **Locating the 360 Degree Cameras** (page 251).
- D See **Locating the Rear Parking Aid Sensors** (page 244).
- E See **Opening and Closing the Hood** (page 396).
- F See **Locating the Pre-Collision Assist Sensors** (page 312).
- G See **Folding the Exterior Mirrors** (page 120).
- H See **Using the High Beam Headlamps** (page 105).

Child Safety

CHILD SAFETY PRECAUTIONS

 **WARNING:** Always make sure your child is secured properly in a device that is appropriate for their height, age and weight. Child safety restraints must be bought separately from your vehicle. Failure to follow these instructions and guidelines may result in an increased risk of serious injury or death to your child.

 **WARNING:** All children are shaped differently. The National Highway Traffic Safety Administration and other safety organizations, base their recommendations for child restraints on probable child height, age and weight thresholds, or on the minimum requirements of the law. We recommend that you check with a NHTSA Certified Child Passenger Safety Technician (CPST) to make sure that you properly install the child restraint in your vehicle and that you consult your pediatrician to make sure you have a child restraint appropriate for your child. To locate a child restraint fitting station and CPST, contact NHTSA toll free at 1-888-327-4236 or go to www.nhtsa.dot.gov. In Canada, contact Transport Canada toll free at

1-800-333-0371 or go to www.tc.gc.ca to find a Child Car Seat Clinic in your area. Failure to properly restrain children in child restraints made especially for their height, age and weight, may result in an increased risk of serious injury or death to your child.

 **WARNING:** On hot days, the temperature inside the vehicle can rise very quickly. Exposure of people or animals to these high temperatures for even a short time can cause death or serious heat related injuries, including brain damage. Small children are particularly at risk.

 **WARNING:** Do not place a rearward facing child restraint in front of an active airbag. Failure to follow this instruction could result in personal injury or death.

 **WARNING:** Properly secure children 12 years old and under in a rear seating position whenever possible. If you are unable to properly secure all children in a rear seating position, properly secure the largest child on the front seat. If you must use a forward facing child restraint on the front seat, move the seat as far back as possible. Failure to follow these instructions could result in personal injury or death.

 **WARNING:** Always carefully follow the instructions and warnings provided by the manufacturer of any child restraint to determine if the restraint device is appropriate for your child's size, height, weight, or age. Follow the child restraint manufacturer's instructions and warnings provided for installation and use in conjunction with the instructions and warnings provided by your vehicle manufacturer. A safety seat that is improperly installed or utilized, is inappropriate for your child's height, age, or weight or does not properly fit the child may increase the risk of serious injury or death.

 **WARNING:** Do not allow a passenger to hold a child on their lap when your vehicle is moving. Failure to follow this instruction could result in personal injury or death in the event of a sudden stop or crash.

 **WARNING:** Do not use pillows, books or towels to boost your child's height. Failure to follow this instruction could result in personal injury or death.

Child Safety

WARNING: Properly secure child restraints or booster seats when they are not in use. They could become projectiles in a sudden stop or crash. Failure to follow this instruction could result in personal injury or death.

WARNING: Do not put the shoulder section of the seatbelt or allow the child to put the shoulder section of the seatbelt under their arm or behind their back. Failure to follow this instruction could reduce the effectiveness of the seatbelt and increase the risk of injury or death in a crash.

WARNING: Do not leave children or pets unattended in your vehicle. Failure to follow this instruction could result in personal injury or death.

When installing a child restraint with seatbelts:

- Place the vehicle seat in the upright position before you install the child restraint.
- Use the correct seatbelt buckle for that seating position.

- Insert the belt tongue into the buckle. Make sure the tongue is securely fastened in the buckle.
- Keep the buckle release button pointing up and away from the child restraint, with the tongue between the child restraint and the release button, to prevent accidental unbuckling.
- Put the seatbelt in the automatic locking mode.

CHILD RESTRAINT ANCHOR POINTS

WHAT ARE THE CHILD RESTRAINT ANCHOR POINTS

Anchor points allow you to quickly and safely install a child restraint.

LOCATING THE CHILD RESTRAINT LOWER ANCHOR POINTS

Second Row Bench Seat

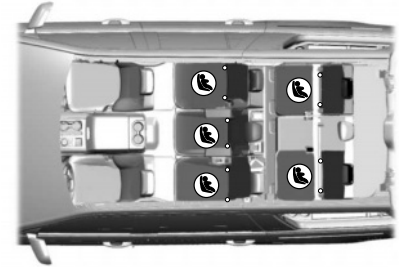

Second Row Bucket Seats

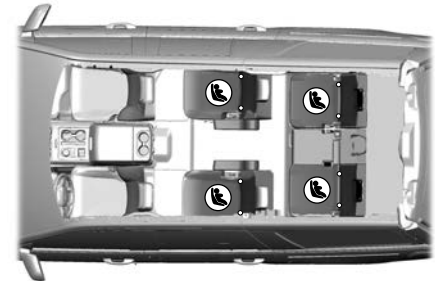

Child Safety

LOCATING THE CHILD RESTRAINT TOP TETHER ANCHOR POINTS

Second Row Bench Seat

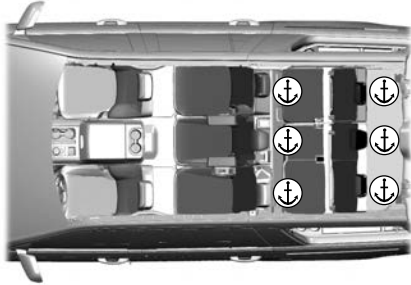

Second Row Bucket Seats

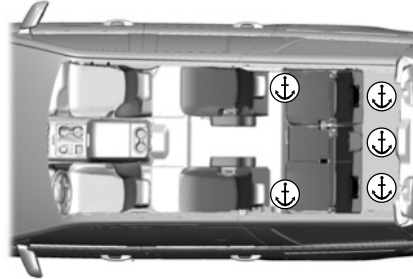

CHILD RESTRAINTS

CHILD RESTRAINT POSITION INFORMATION

Install the child restraint tightly against the vehicle seat. It may be necessary to lift or remove the head restraint.

Rear Facing Child Restraints

Combined Weight of Child and Child Restraint	LATCH (Lower Anchors Only)	Seatbelt Only
Up to 65 lb (29 kg)	X	X
Over 65 lb (29 kg)		X

Child Safety

Forward Facing Child Restraints

Combined Weight of Child and Child Restraint	LATCH (Lower Anchors and Top Tether Anchor)	Seatbelt and Top Tether Anchor	Seatbelt and LATCH (Lower Anchors and Top Tether Anchor)
Up to 65 lb (29 kg)	X	X	X
Over 65 lb (29 kg)		X	X

Child Safety

CHILD RESTRAINTS RECOMMENDATION

Child Size, Height, Weight, or Age	Recommended Restraint Type
Children weighing 40 lb (18 kg) or less (generally age four or younger).	Use a child restraint (sometimes called an infant carrier, convertible seat, or toddler seat).
Children who have outgrown or no longer properly fit in a child restraint (generally children who are less than 57 in (1.45 m) tall, are greater than age four and less than age 12, and between 40 lb (18 kg) and 80 lb (36 kg) and upward to 100 lb (45 kg) if recommended by your child restraint manufacturer).	Use a belt-positioning booster seat.
Children who have outgrown or no longer properly fit in a belt-positioning booster seat (generally children who are at least 57 in (1.45 m) tall or greater than 80 lb (36 kg) or 100 lb (45 kg) if recommended by child restraint manufacturer).	Use a vehicle seatbelt having the lap belt snug and low across the hips, shoulder belt centered across the shoulder and chest, and seat backrest upright.

You are required by law to properly use child restraints for infants and toddlers in the United States, Canada and Mexico.

Many states and provinces require that small children use approved booster seats until they reach age eight, a height of 57 in (1.45 m) tall, or 80 lb (36 kg). Check your local and state or provincial laws for specific requirements about the safety of children in your vehicle.

When possible, properly restrain children 12 years of age and under in a rear seating position of your vehicle. Accident statistics suggest that children are safer when properly restrained in the rear seating positions than in a front seating position.

When installing a rear facing child restraint, adjust the vehicle seats to avoid interference between the child restraint and the vehicle seat in front of the child restraint.

Child Safety

INSTALLING CHILD RESTRAINTS

USING SEATBELTS

 **WARNING:** Depending on where you secure a child restraint, and depending on the child restraint design, you may block access to certain seatbelt buckle assemblies and LATCH lower anchors, rendering those features potentially unusable. To avoid risk of injury, make sure occupants only use seating positions where they are able to be properly restrained.

Note: Although the child restraint illustrated is a forward facing child restraint, the steps are the same for installing a rear facing child restraint.

Perform the following steps when installing a child restraint with seatbelts.

1. Position the child restraint in a seat with a seatbelt.



2. Pull down on the shoulder belt and then grasp the shoulder belt and lap belt together.



3. While holding the shoulder and lap belt portions together, route the tongue through the child restraint according to the child restraint manufacturer's instructions. Make sure you did not twist the belt webbing.

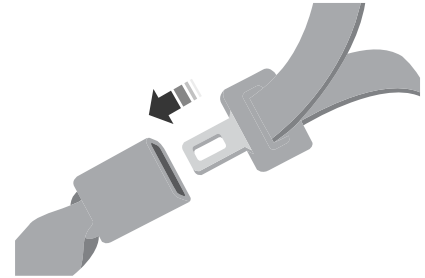

4. Insert the belt tongue into the proper buckle for that seating position until the latch engages. Make sure the tongue is latched securely by pulling on it.

Child Safety



5. To put the retractor in the automatic locking mode, grasp the shoulder portion of the belt and pull downward until you pull all of the seatbelt out.

Note: *The automatic locking mode is available on the front passenger and rear seats. This vehicle does not require the use of a locking clip.*

6. Allow the belt to retract to remove slack. The seatbelt clicks as it retracts to indicate it is in the automatic locking mode.

7. Pull the seatbelt out of the retractor to make sure the retractor is in the automatic locking mode. You should not be able to pull more belt out. If the retractor is not locked, unbuckle the belt and repeat Steps 5 and 6.



8. Remove remaining slack from the belt. Force the seat down with extra weight, for example, by pressing down or kneeling on the child restraint while pulling up on the shoulder belt in order to force slack from the belt. This is necessary to remove the remaining slack that exists once you

add the extra weight of the child to the child restraint. It also helps to achieve the proper snugness of the child restraint to your vehicle. Sometimes, a slight lean toward the buckle helps to remove remaining slack from the belt.

9. If the child restraint has a tether strap, attach it.

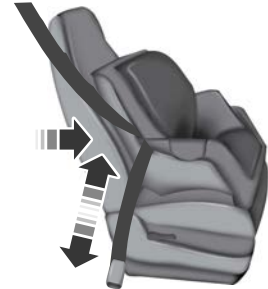

10. Before placing the child in the seat, forcibly move the seat forward and back to make sure the seat is securely held in place.

To check this, grab the seat at the belt path and attempt to move it side to side and forward and back. There should be no more than 1 in (2.5 cm) of movement.

Child Safety

We recommend checking with a NHTSA Certified Child Passenger Safety Technician to make certain the child restraint is properly installed. In Canada, check with Transport Canada for referral to a Child Car Seat Clinic.

USING LOWER ANCHORS AND TETHERS FOR CHILDREN



WARNING: Do not attach two child safety restraints to the same anchor. In a crash, one anchor may not be strong enough to hold two child safety restraint attachments and may break, causing serious injury or death.



WARNING: Depending on where you secure a child restraint, and depending on the child restraint design, you may block access to certain seatbelt buckle assemblies and LATCH lower anchors, rendering those features potentially unusable. To avoid risk of injury, make sure occupants only use seating positions where they are able to be properly restrained.

The Lower Anchors and Tethers for Children (LATCH) system has three vehicle anchor points:

- Two lower anchors where the vehicle seat backrest and seat cushion meet, called the seat bight.
- One top tether anchor behind that seating position.

LATCH compatible child restraints have two rigid or webbing mounted attachments. These attachments connect to the two lower anchors at the LATCH equipped seating positions in your vehicle. This type of attachment method eliminates the need to use seatbelts to attach the child restraint.

However, you can still use the seatbelt to attach the child restraint if the lower anchors are not used. For forward-facing child restraints, you must also attach the top tether strap to the proper top tether anchor if a top tether strap has been provided with your child restraint.

Follow the instructions later in this chapter on attaching child restraints with tether straps.

INSTALLING A CHILD RESTRAINT IN A CENTER SEAT



WARNING: The standardized spacing for LATCH lower anchors is 11 in (280 mm) center to center. Do not use LATCH lower anchors for the center seating position unless the child restraint manufacturer's instructions permit and specify using anchors spaced at least as far apart as those in this vehicle.

The lower anchors at the center of the second-row rear seat are spaced 11 in (280 mm) apart. The lower anchors at the center of the third-row rear seats are spaced 19 in (488 mm) apart. The standardized spacing for LATCH lower anchors is 11 in (280 mm) center to center.

You cannot install a child restraint with rigid LATCH attachments at the third-row center seating position. You can only use LATCH compatible child restraints with attachments on belt webbing at this seating position provided that the child restraint manufacturer's instructions permit use with the anchor spacing stated. Do not attach a child restraint to any lower anchor if another child restraint is attached to that anchor.

Child Safety

Each time you use the child restraint, check that the seat is properly attached to the lower anchors and tether anchor, if applicable. Tug the child restraint from side to side and forward and back where it is secured to the vehicle. The seat should move less than 1 in (2.5 cm).

If you did not properly anchor the child restraint, the risk of a child being injured in a crash greatly increases.

COMBINING THE SEATBELT AND LOWER ANCHORS FOR ATTACHING CHILD RESTRAINTS

When used in combination, you may attach either the seatbelt or the LATCH lower anchors first, provided a proper installation is achieved. Attach the tether strap afterward, if it is included with the child restraint.

USING TETHER STRAPS

Many forward-facing child restraints include a tether strap which extends from the back of the child restraint and hooks to an anchoring point called the top tether anchor. Tether straps are available as an accessory for many older child restraints.

Contact the manufacturer of your child restraint for information about ordering a tether strap, or to obtain a longer tether strap if the tether strap on your child restraint does not reach the appropriate top tether anchor in the vehicle.

Attach the tether strap only to the appropriate tether anchor. The tether strap may not work properly if attached somewhere other than the correct tether anchor.

If you install a child restraint with rigid LATCH attachments, do not tighten the tether strap enough to lift the child restraint off the vehicle seat cushion when the child is seated in it. Keep the tether strap just snug without lifting the front of the child restraint. Keeping the child restraint just touching the vehicle seat gives the best protection in a severe crash.

Once you have installed the child restraint using either the seatbelt, the lower anchors of the LATCH system, or both, you can attach the top tether strap.

BOOSTER SEATS

Use a belt-positioning booster seat for children who have outgrown or no longer properly fit in a child restraint and meet the following criteria.

- Generally children who are less than 57 in (1.45 m) tall.
- Are greater than age four (4) and less than age twelve (12).
- Are between 40 lb (18 kg) and 80 lb (36 kg) and upward to 100 lb (45 kg).

Many state and provincial laws require that children use approved booster seats until they reach age eight, a height of 57 in (1.45 m) tall, or 80 lb (36 kg).

Booster seats should be used until you can answer yes to all of these questions when seated without a booster seat:

Child Safety

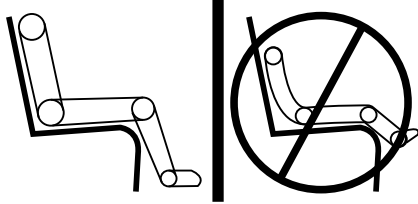

Types of Booster Seats



- Backless booster seats

If your backless booster seat has a removable shield, remove the shield.

If a vehicle seating position has a low seat backrest or no head restraint, a backless booster seat may place your child's head, as measured at the tops of the ears, above the top of the seat. In this case, move the backless booster to another seating position with a higher seat backrest or head restraint and lap and shoulder belts, or consider using a high-back booster seat.



- High-back booster seats

If, with a backless booster seat, you cannot find a seating position that adequately supports your child's head, a high-back booster seat would be a better choice.

Children and booster seats vary in size and shape. Choose a booster that keeps the lap belt low and snug across the hips, never up across the stomach, and lets you adjust the shoulder belt to cross the chest and rest snugly near the center of the shoulder.

The following drawings compare the ideal fit to a shoulder belt uncomfortably close to the neck and a shoulder belt that could slip off the shoulder. The drawings also show how the lap belt should be low and snug across the child's hips.

- Can the child sit all the way back against their vehicle seat backrest with knees bent comfortably at the edge of the seat cushion?
- Can the child sit without slouching?
- Does the lap belt rest low across the hips?
- Is the shoulder belt centered on the shoulder and chest?
- Can the child stay seated like this for the whole trip?

Always use booster seats in conjunction with your vehicle lap and shoulder belt.

Child Safety



Child Safety

If the booster seat slides on the vehicle seat upon which it is being used, placing a rubberized mesh sold as shelf or carpet liner under the booster seat may improve this condition. Do not use any item thicker than this under the booster seat. Check with the booster seat manufacturer's instructions.

CHILD SAFETY LOCKS



WARNING: You cannot open the rear doors from inside if you have put the child safety locks on.



A child safety lock is on the rear edge of each rear door and must be set separately for each door.

Left-Hand Side

Turn it clockwise to switch the child lock on and counterclockwise to switch it off.

Right-Hand Side

Turn it counterclockwise to switch the child lock on and clockwise to switch it off.

Note: To make sure the child safety lock is on, pull the inside door handle twice to verify the door does not open.

Note: To open the rear doors from inside the vehicle when the child lock is engaged, roll down the rear window and use the outside door handle. Or have someone outside the vehicle open the door.

Seatbelts

SEATBELT PRECAUTIONS

 **WARNING:** Always drive and ride with your seatback upright and the lap belt snug and low across the hips.

 **WARNING:** Children must always be properly restrained.

 **WARNING:** Do not allow a passenger to hold a child on their lap when your vehicle is moving. Failure to follow this instruction could result in personal injury or death in the event of a sudden stop or crash.

 **WARNING:** All occupants of your vehicle, including the driver, should always properly wear their seatbelts, even when an airbag supplemental restraint system is provided. Failure to properly wear your seatbelt could seriously increase the risk of injury or death.

 **WARNING:** It is extremely dangerous to ride in a cargo area, inside or outside of a vehicle. In a crash, people riding in these areas are more likely to be seriously injured or killed. Do not allow people to ride in any area of your vehicle that is not equipped with seats and seatbelts. Make sure everyone in your vehicle is in a seat and properly using a seatbelt. Failure to follow this warning could result in serious personal injury or death.

 **WARNING:** In a rollover crash, an unbelted person is significantly more likely to die than a person wearing a seatbelt.

 **WARNING:** Each seating position in your vehicle has a specific seatbelt assembly made up of one buckle and one tongue designed to be used as a pair. Use the shoulder belt on the outside shoulder only. Never wear the shoulder belt under the arm. Never use a single seatbelt for more than one person.

 **WARNING:** Even with advanced restraints systems, properly restrain children 12 and under in a rear seating position. Failure to follow this could seriously increase the risk of injury or death.

 **WARNING:** Seatbelts and seats may be hot in a vehicle that is in the sunshine. The hot seatbelts or seats may burn a small child. Check seat covers and buckles before you place a child anywhere near them.

 **WARNING:** If your vehicle is involved in a crash, have the seatbelts and associated components inspected as soon as possible. Failure to follow this instruction could result in personal injury or death.

All seating positions in this vehicle have seatbelts. All occupants of the vehicle should properly wear their seatbelts, even when an airbag supplemental restraint system is provided.

The seatbelt system consists of:

- Lap and shoulder seatbelts.
- A shoulder seatbelt with automatic locking mode, except driver seatbelt.
- Height adjusters at the front outermost seating positions.
- Seatbelt pretensioners at the front row and second row outermost seating positions.

Seatbelts



A seatbelt warning light and chime.



Crash sensors and monitoring system with readiness indicator.

The seatbelt pretensioners are designed to tighten the seatbelts when activated. In frontal and near-frontal crashes, the seatbelt pretensioners may be activated alone or, if the crash is of sufficient severity, together with the front airbags. In side crashes and rollovers, the pretensioners will be activated when the Safety Canopy is activated.

FASTENING AND UNFASTENING THE SEATBELTS

All seatbelts in your vehicle are a three-point combination lap and shoulder seatbelt.

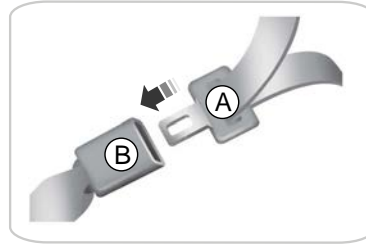

- A Seatbelt tongue.
- B Seatbelt buckle.

1. Pull the seatbelt out steadily.

Note: It may lock if you pull it sharply or if the vehicle is on a slope.

2. Insert the tongue into the buckle.
3. Pull the seatbelt tight to remove any slack.

Unfastening the Seatbelts

1. Press the red button on the buckle to release the seatbelt.
2. Hold the seatbelt tongue and let it retract completely and smoothly to its stowed position.

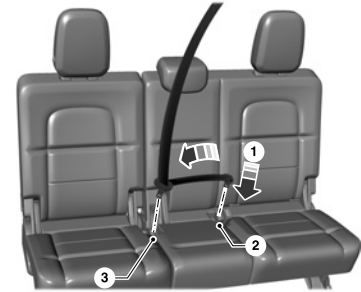

The retractor for the third row center seatbelt is in the roof.

To fasten the seatbelt:

1. Pull the belt out steadily. It may lock if you pull it sharply or if the vehicle is on a slope.
2. Insert the smaller tongue into the smaller buckle to the left of the center seat.

Seatbelts

3. Pull the larger tongue across the lap and insert it into the buckle to the right of the center seat.

Note: *If in constant use, you can leave the belt buckled in the smaller buckle. When it is not in use, or when you fold or move the rear seats, you should release the belt from the smaller buckle. Using the tongue of the adjacent seatbelt, press the red button on the smaller buckle.*

SENSITIVE LOCKING MODE

WHAT IS SENSITIVE LOCKING MODE

Sensitive locking mode is a seatbelt retractor feature that allows shoulder belt length adjustment according to your movements and locking in response to vehicle movement.

HOW DOES SENSITIVE LOCKING MODE WORK

If the driver suddenly brakes, turns a corner sharply, or the vehicle receives an impact of about 5 mph (8 km/h) or more, the seatbelts lock to help reduce forward movement of the driver and passengers.

In addition, the seatbelt retractor locks if you pull the seatbelt webbing out too quickly. If the retractor locks, slowly lower the height adjuster to allow the seatbelt to retract.

If the retractor does not unlock, pull the seatbelt out slowly then feed a small length of webbing back toward the stowed position.

For rear seatbelts, recline the rear seat backrest or push the seat backrest cushion away from the seatbelt. Feed a small length of webbing back toward the stowed position.

AUTOMATIC LOCKING MODE

WHAT IS AUTOMATIC LOCKING MODE

This feature keeps the seatbelts pre-locked. The belt still retracts to remove any slack in the shoulder belt.

WHEN TO USE AUTOMATIC LOCKING MODE

Use this mode any time you install a child restraint in the front passenger seating position or any rear seating position. Properly restrain children 12 years old and under in a rear seat whenever possible.

Note: *Automatic locking mode is not available on the driver seatbelt.*

ENGAGING AUTOMATIC LOCKING MODE



1. Fasten the combination lap and shoulder belt.
2. Grasp the shoulder portion and pull downward until you pull the entire belt out.
3. Allow the belt to retract. As the belt retracts, you will hear a clicking sound. This indicates the seatbelt is now in the automatic locking mode.

Seatbelts

DISENGAGING AUTOMATIC LOCKING MODE

Unbuckle the combination lap and shoulder belt and allow it to retract completely to disengage the automatic locking mode and activate the vehicle sensitive locking mode.

ADJUSTING THE SEATBELTS DURING PREGNANCY

WARNING: Always ride and drive with your seatback upright and properly fasten your seatbelt. Fit the lap portion of the seatbelt snugly and low across the hips. Position the shoulder portion of the seatbelt across your chest. Pregnant women must follow this practice. See the following figure.

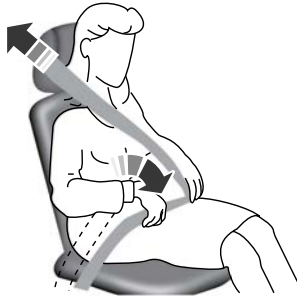

Pregnant women should always wear their seatbelt. Position the lap belt portion of a combination lap and shoulder belt low across the hips below the belly and worn as tight as comfort allows. Position the shoulder belt to cross the middle of the shoulder and the center of the chest.

ADJUSTING THE SEATBELT HEIGHT

WARNING: Position the seatbelt height adjuster so that the seatbelt rests across the middle of your shoulder. Failure to adjust the seatbelt correctly could reduce its effectiveness and increase the risk of injury in a crash.



1. Press the button and slide the height adjuster up or down.
2. Release the button and pull down on the height adjuster to make sure it is locked in place.

Seatbelts

SEATBELT REMINDER

HOW DOES THE SEATBELT REMINDER WORK



WARNING: The system will only provide protection when you use the seatbelt correctly.

This feature provides an audible or visual alert when you or an occupant unfastens a seatbelt.

The alert remains on until:

- You open and close a door.
- You fasten the seatbelt for any seat that is occupied.
- You switch the vehicle off and then on.

SEATBELT REMINDER INDICATORS



This lamp illuminates if you do not fasten your seatbelt when you switch the ignition on. The lamp switches off when you fasten your seatbelt or about one minute has elapsed.

When the initial warning expires for the driver, more warnings are provided for the driver and front passenger. This lamp illuminates if you or your front passenger do not fasten the seatbelt buckle and the vehicle speed exceeds 6 mph (10 km/h).

Note: To avoid inadvertent warnings, do not place large objects on the front passenger seat.

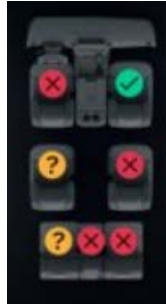

This warning displays if an occupant unfastens the rear seatbelt buckle or it becomes unfastened.



- A Seatbelt fastened.
- B Seatbelt not fastened.
- C Fault.
- D Seatbelt recently unfastened.

Note: If a rear seat is unoccupied, or an occupant never fastens the seatbelt buckle to begin with, the warning will not display.

Note: Front seating positions appear in this warning display. Warnings for unfastened front seatbelt buckles appear in the initial warning lamp.

Seatbelts

SEATBELT REMINDER AUDIBLE WARNINGS

A warning tone sounds if you do not fasten your seatbelt when you switch the ignition on. The tone switches off when you fasten your seatbelt or about one minute elapses.

When the initial warning expires for the driver, more warnings are provided for the driver and front passenger. This warning tone sounds if you or your front passenger do not fasten the seatbelt buckle and the vehicle speed exceeds 6 mph (10 km/h).

This tone also sounds if an occupant unfastens the rear seatbelt buckle or it becomes unfastened.

SWITCHING THE SEATBELT REMINDER ON AND OFF



WARNING: While the system allows you to deactivate it, this system is designed to improve your chances of being safely belted and surviving an accident. We recommend you leave the system activated for yourself and others who may use the vehicle.

Note: *The driver and front passenger warnings switch off independently. When you perform this procedure for one seating position and the other seat is occupied, fasten the other seat.*

Read Steps 1-4 before proceeding with the programming procedure.

Make sure that:

- You set the parking brake.
 - The transmission is in park (P).
 - The ignition is off.
 - You close all vehicle doors.
 - You unfasten the driver and front passenger seatbelts.
1. Start the engine.
 2. Wait a short period of time until the seatbelt warning light switches off. After Step 2, wait an additional five seconds before proceeding with Step 3. Once you start Step 3, complete the procedure within 30 seconds.
 3. For the seating position you are switching off, fasten then unfasten the seatbelt four times at a moderate speed, ending in the unfastened state. After each unfasten, the seatbelt warning light switches on and off with each fasten.
 4. The seatbelt warning light flashes for confirmation.

This switches the feature off for that seating position if it is currently on.

This switches the feature on for that seating position if it is currently off.

CHECKING THE SEATBELTS

Check the seatbelts and child restraints periodically to make sure they work properly and are not damaged. Make sure there are no nicks, tears or cuts. Replace if necessary.

Check the following seatbelt assemblies after a crash.

- Retractors.
- Buckles.
- Front seatbelt buckle assemblies.
- Shoulder belt height adjusters.
- Shoulder belt guide on seat backrest.
- Child restraint LATCH and tether anchors.
- Attaching hardware.

Read the child restraint manufacturer's instructions for additional inspection and maintenance information specific to the child restraint.

Seatbelts

We recommend that all seatbelt assemblies in use in vehicles involved in a crash be replaced. However, if the crash was minor and an authorized dealer finds that the belts do not show damage and continue to operate properly, they do not need to be replaced. Seatbelt assemblies not in use during a crash should also be checked and replaced if either damage or improper operation is noted.

Properly care for seatbelts. See **Cleaning Seatbelts** (page 421).

SEATBELT EXTENSIONS

 **WARNING:** Persons who fit into the vehicle's seatbelt should not use an extension. Unnecessary use could result in serious personal injury in the event of a crash.

 **WARNING:** Only use extensions provided free of charge by our dealers. The dealer will provide an extension designed specifically for this vehicle, model year and seating position. The use of an extension intended for another vehicle, model year or seating position may not offer you the full protection of your vehicle's seatbelt restraint system.

 **WARNING:** Never use seatbelt extensions to install child restraints.

 **WARNING:** Do not use extensions to change the way the seatbelt fits across the torso, over the lap or to make the seatbelt buckle easier to reach.

If, because of body size or driving position, it is not possible to properly fasten the seatbelt over your lap and shoulder, an extension that is compatible with the seatbelts is available free of charge from our dealers. Only use our seatbelt extensions made by the original equipment seatbelt manufacturer with our seatbelts. Ask your authorized dealer if your extension is compatible with your vehicle restraint system.

Personal Safety System™

WHAT IS THE PERSONAL SAFETY SYSTEM

An advanced safety system that protects occupants in frontal crashes.

HOW DOES THE PERSONAL SAFETY SYSTEM WORK

This system provides an improved level of frontal crash protection to front seat occupants and is designed to reduce the risk of airbag-related injuries. The system analyzes occupant conditions and crash severity before activating the appropriate safety devices. During a crash, the restraints control module may deploy the seatbelt pretensioners, and one or both stages of the dual-stage airbags based on crash severity and occupant conditions.

PERSONAL SAFETY SYSTEM COMPONENTS

- Driver and passenger dual-stage airbag supplemental restraints.
- Front seat outermost seatbelts with pretensioners, energy management retractors and seatbelt usage sensors.

- Driver seat position sensor.
- Front passenger sensing system.
- Passenger airbag off and on indicators.
- Front crash severity sensors.
- Restraints control module with impact and safing sensors.
- Restraint system warning light and tone.
- The electrical wiring for the airbags, crash sensors, seatbelt pretensioners, front seatbelt usage sensors, driver seat position sensor, front passenger sensing system and indicator lights.

Airbags

HOW DO THE FRONT AIRBAGS WORK

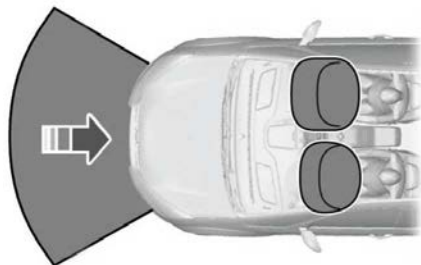

The driver and front passenger airbags deploy during significant frontal and near frontal crashes.

The driver and passenger front airbag system consists of:

- Driver and passenger airbag modules.
- Front passenger sensing system.
- Crash sensors and monitoring system with readiness indicator. See **Crash Sensors and Airbag Indicator** (page 60).

The airbags are a supplemental restraint system and are designed to work with the seatbelts to help protect the driver and right front passenger from certain upper body injuries. Airbags do not inflate slowly; there is a risk of injury from a deploying airbag.

Note: *You will hear a loud bang and see a cloud of harmless powdery residue if an airbag deploys. This is normal.*

The airbags inflate and deflate rapidly upon activation. After airbag deployment, it is normal to notice a smoke-like, powdery residue or smell the burnt propellant. This may consist of cornstarch, talcum powder (to lubricate the bag) or sodium compounds (for example, baking soda) that result from the combustion process that inflates the airbag. Small amounts of sodium hydroxide may be present which may irritate the skin and eyes, but none of the residue is toxic.

Contact with a deploying airbag may cause abrasions or swelling. Temporary hearing loss is also a possibility as a result of the noise associated with a deploying airbag.

Because airbags must inflate rapidly and with considerable force, there is the risk of death or serious injuries such as fractures, facial and eye injuries or internal injuries, particularly to occupants who are not properly restrained or are otherwise out of position at the time of airbag deployment. Thus, it is extremely important that occupants be properly restrained as far away from the airbag module as possible.

Routine maintenance of the airbags is not required.

HOW DO THE SIDE AIRBAGS WORK



WARNING: Do not place objects or mount equipment on or near the airbag cover, on the side of the front seat backrests, or in areas that may come into contact with a deploying airbag. Failure to follow this instruction could result in personal injury or death.

Airbags

⚠ WARNING: Do not use accessory seat covers. The use of accessory seat covers may prevent the deployment of the airbags and the seatbelt from retracting correctly which could increase the risk of injuries in a crash.

⚠ WARNING: Do not lean your head on the door. The side airbag could injure you as it deploys from the side of the seatback.

The side airbags are on the outermost side of the front seat backrests. In certain sideways crashes or rollovers, the airbags inflate. The airbag was designed to inflate between the door panel and occupant to further enhance the protection provided to occupants in side impact crashes.



The system consists of:

- A label or embossed side panel indicating that the vehicle has side airbags.
- Side airbags inside the driver and front passenger seat backrests.
- Crash sensors and monitoring system with a readiness indicator. See **Crash Sensors and Airbag Indicator** (page 60).

HOW DOES THE SAFETY CANOPY™ WORK

⚠ WARNING: Do not place objects or mount equipment on or near the headliner at the siderail that may come into contact with a deploying curtain airbag. Failure to follow these instructions may increase the risk of personal injury in the event of a crash.

⚠ WARNING: Do not lean your head on the door. The curtain airbag could injure you as it deploys from the headliner.

⚠ WARNING: To reduce risk of injury, do not obstruct or place objects in the deployment path of the airbag.

The Safety Canopy deploys during significant side crashes or when a certain likelihood of a rollover event is detected by the rollover sensor. The Safety Canopy is mounted to the roof side-rail sheet metal, behind the headliner, above each row of seats. In certain sideways crashes or rollover events, the

Airbags

Safety Canopy will be activated, regardless of which seats are occupied. The Safety Canopy inflates between the side window area and occupants to further enhance protection provided in side impact crashes and rollover events.

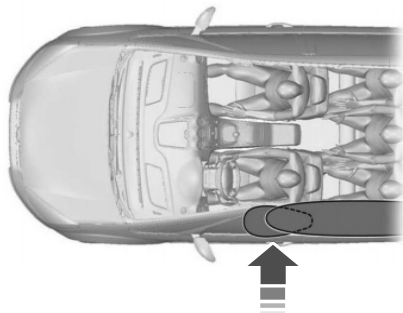

The system consists of the following:

- Safety Canopy curtain airbags above the trim panels over the front and rear side windows identified by a label or wording on the headliner or roof-pillar trim.
- A flexible headliner which opens above the side doors to allow air curtain deployment



• Crash sensors and monitoring system with a readiness indicator. See **Crash Sensors and Airbag Indicator** (page 60).

Properly restrain children 12 years old and under in the rear seats. The Safety Canopy will not interfere with children restrained using a properly installed child or booster seat because it is designed to inflate downward from the headliner above the doors along the side window opening.

AIRBAG PRECAUTIONS



WARNING: Airbags do not inflate slowly or gently, and the risk of injury from a deploying airbag is the greatest close to the trim covering the airbag module.



WARNING: All occupants of your vehicle, including the driver, should always properly wear their seatbelts, even when an airbag supplemental restraint system is provided. Failure to properly wear your seatbelt could seriously increase the risk of injury or death.



WARNING: Properly secure children 12 years old and under in a rear seating position whenever possible. If you are unable to properly secure all children in a rear seating position, properly secure the largest child on the front seat. If you must use a forward facing child restraint on the front seat, move the seat as far back as possible. Failure to follow these instructions could result in personal injury or death.



WARNING: Do not place your arms on the airbag cover or through the steering wheel. Failure to follow this instruction could result in personal injury.





WARNING: Keep the areas in front of the airbags free from obstruction. Do not affix anything to or over the airbag covers. Objects could become projectiles during airbag deployment. Failure to follow this instruction could result in personal injury or death.





WARNING: To reduce risk of injury, do not obstruct or place objects in the deployment path of the airbag.

Airbags

 **WARNING:** Do not place a rearward facing child restraint in front of an active airbag. Failure to follow this instruction could result in personal injury or death.

 **WARNING:** Do not attempt to service, repair, or modify the supplementary restraint system or associated components. Failure to follow this instruction could result in personal injury or death.

 **WARNING:** Several airbag system components get hot after inflation. To reduce the risk of injury, do not touch them after inflation.

 **WARNING:** If a supplementary restraint system component has deployed, it will not function again. Have the system and associated components inspected as soon as possible. Failure to follow this instruction could result in personal injury or death.

PROPERLY ADJUSTING THE DRIVER AND FRONT PASSENGER SEATS

 **WARNING:** National Highway Traffic Safety Administration (NHTSA) recommends a minimum distance of at least 10 in (25 cm) between an occupant's chest and the driver airbag module.

To properly position yourself away from the airbag:

- Move your seat to the rear as far as you can while still reaching the pedals comfortably.
- Recline the seat slightly one or two degrees from the upright position.

After all occupants have adjusted their seats and put on seatbelts, it is very important that they continue to sit properly. Properly seated occupants sit upright, lean against the seat backrest, and center themselves on the seat cushion, with their feet comfortably extended on the floor. Sitting improperly can increase

the chance of injury in a crash event. For example, if an occupant slouches, lies down, turns sideways, sits forward, leans forward or sideways, or puts one or both feet up, the chance of injury during a crash greatly increases.

CHILDREN AND AIRBAGS

 **WARNING:** Do not place a rearward facing child restraint in front of an active airbag. Failure to follow this instruction could result in personal injury or death.



Airbags

Children must always be properly restrained. Accident statistics suggest that children are safer when properly restrained in the rear seating positions than in the front seating position. Failure to follow these instructions may increase the risk of injury in a crash.

If two adults and a child occupy a vehicle without rear seats, properly restrain the child in the center front seat unless doing so would interfere with driving your vehicle. This provides lap and shoulder belt protection for all occupants, and airbag protection for the adults. A child or infant properly restrained in the center front seat should have a reduced risk to serious injury from the airbags.

FRONT PASSENGER SENSING SYSTEM

WHAT IS THE FRONT PASSENGER SENSING SYSTEM

This system detects a properly seated occupant and determines if the front passenger airbag should be enabled.

HOW DOES THE FRONT PASSENGER SENSING SYSTEM WORK

The system uses a passenger airbag status indicator which illuminates indicating that the front passenger frontal airbag is either enabled or disabled.

Note: *When you first switch the ignition on, the passenger airbag status indicator off and on lamps illuminate for a short period to confirm they are functional.*



The indicator lamps are in the overhead console.

The front passenger sensing system is designed to disable the front passenger frontal airbag under these conditions:

- The front passenger seat is unoccupied.
- The system determines an infant is present in a child restraint.

- A passenger takes their weight off of the seat for a period of time.
- If there is a problem with the airbag system or the passenger sensing system.

Note: *Even with this technology, parents are strongly encouraged to always properly restrain children in the rear seat.*

- When the front passenger sensing system disables the front passenger frontal airbag, the passenger airbag status indicator illuminates the off lamp.
- If you have installed the child restraint and the passenger airbag status indicator illuminates the on lamp, switch your vehicle off, remove the child restraint from your vehicle and reinstall the restraint following the child restraint manufacturer's instructions.

The front passenger sensing system works with sensors that are part of the front passenger seat and seatbelt. The sensors are designed to detect the presence of a properly seated occupant and determine if the front passenger frontal airbag should be enabled.

- When the front passenger sensing system enables the front passenger frontal airbag, the passenger airbag status indicator illuminates the on lamp.

Airbags

If a person of adult size is sitting in the front passenger seat, but the passenger airbag status indicator off lamp is illuminated, it is possible that the person is not sitting properly in the seat. If this happens:

- Switch your vehicle off and ask the person to place the seat backrest in an upright position.
- Have the person sit upright in the seat, centered on the seat cushion, with the person's legs comfortably extended.
- Restart your vehicle and have the person remain in this position for about two minutes. This allows the system to detect that person and enable the passenger frontal airbag.
- If the indicator off lamp remains illuminated even after this, you should advise the person to ride in the rear seat.

After all occupants have adjusted their seats and put on seatbelts, it is very important that they continue to sit upright, leaning against the seat backrest, and centered on the seat cushion, with their feet comfortably extended on the floor.

Sitting improperly can increase the chance of injury in a crash event. For example, if an occupant slouches, lies down, turns sideways, sits forward, leans forward or sideways, or puts one or both feet up, the chance of injury during a crash greatly increases.

If you think that the state of the passenger airbag status indicator lamp is incorrect, check for the following:

- Objects lodged underneath the seat.
- Objects between the seat cushion and the center console.
- Objects hanging off the seat backrest.
- Objects stowed in the seat backrest map pocket.
- Objects placed on the occupant's lap.
- Cargo interference with the seat
- Other passengers pushing or pulling on the seat.
- Rear passenger feet and knees resting or pushing on the seat.

The listed conditions could cause the weight of a properly seated occupant to be incorrectly interpreted by the front passenger sensing system. The person in the front passenger seat could appear heavier or lighter due to the conditions listed.



Make sure the front passenger sensing system is operating properly. See **Crash Sensors and Airbag Indicator** (page 60).

If the airbag readiness light is on, do the following:

- Pull your vehicle over.
- Switch your vehicle off.
- Check for any objects lodged underneath the front passenger seat or cargo interfering with the seat.
- Remove the obstruction if found.
- Restart your vehicle.
- Wait at least two minutes and verify that the airbag readiness light in the instrument cluster is no longer illuminated.
- If the airbag readiness light in the instrument cluster remains illuminated, there may be a problem due to the front passenger sensing system.

Do not attempt to repair or service the system. Take your vehicle in for service immediately.

Airbags

If it is necessary to modify an advanced front airbag system to accommodate a person with disabilities, contact your Customer Relationship Center. See **Contacting Us** (page 15).

FRONT PASSENGER SENSING SYSTEM PRECAUTIONS

 **WARNING:** Sitting improperly, out of position or with the seatback reclined too far can take weight off the seat cushion and affect the decision of the passenger sensing system, resulting in serious injury or death in the event of a crash. Always sit upright against your seat back, with your feet on the floor.

 **WARNING:** Any alteration or modification to the front passenger seat may affect the performance of the front passenger sensing system. This could seriously increase the risk of injury or death.

 **WARNING:** Do not place objects under the front passenger seat or between the seat and the center console. Failure to follow this instruction may interfere with the front passenger seat sensing system and increase the risk of injury or death in a crash.

 **WARNING:** Check the passenger airbag indicator lamp for proper airbag status. Failure to follow this instruction could result in personal injury or death.

FRONT PASSENGER SENSING SYSTEM INDICATORS

Occupant	Passenger Airbag Status Indicator	Passenger Airbag
Empty	OFF: Illuminated	Disabled
	ON: Not Illuminated	
Child	OFF: Illuminated	Disabled

Airbags

Occupant	Passenger Airbag Status Indicator	Passenger Airbag
	ON: Not Illuminated	
Adult	OFF: Not Illuminated	Enabled
	ON: Illuminated	

CRASH SENSORS AND AIRBAG INDICATOR



WARNING: Modifying or adding equipment to the front of your vehicle could affect the performance of the airbag system, increasing the risk of injury. This includes the hood, bumper system, frame, front body structure, tow hooks, hood pins, push bar and snowplows.

Your vehicle has a collection of crash and occupant sensors. These sensors provide information to the restraints control module which activates the following:

- Front seatbelt pretensioners.
- Adaptive steering column.
- Driver airbag.
- Passenger airbag.

- Seat mounted side airbags.
- Safety Canopy.

Based on the type of crash, the restraints control module deploys the appropriate safety devices.

The restraints control module also monitors the readiness of the above safety devices plus the crash and occupant sensors. The readiness of the safety system is indicated by a warning indicator light in the instrument cluster or by a backup tone if the warning light is not working. Routine maintenance of the airbag is not required.

A difficulty with the system is indicated by one or more of the following:



The readiness light will not illuminate immediately after you switch the ignition on.

- The readiness light either flashes or stays on.
- You hear a series of five tones. The tone pattern repeats periodically until the problem, the light or both are repaired.

If any of these things happen, even intermittently, have the supplemental restraint system serviced immediately. Unless serviced, the system may not function properly in the event of a crash.

Airbags

The fact that the seatbelt pretensioners or front airbags did not activate for both front seat occupants in a crash does not mean that something is wrong with the system. Rather, it means the restraints control module determined the accident conditions (crash severity, seatbelt usage) were not appropriate to activate these safety devices.

- The front airbags activate only in frontal and near-frontal crashes. Front airbags may activate in rollovers, side impacts or rear impacts if the crash causes sufficient frontal deceleration.
- The seatbelt pretensioners activate in frontal, near-frontal and side crashes, and in rollovers.
- The side airbags inflate in certain side impact crashes or rollover events. Side airbags may activate in other types of crashes if the vehicle experiences sufficient sideways motion or deformation.
- The Safety Canopy inflates in certain side impact crashes or rollover events. The Safety Canopy may activate in other types of crashes if the vehicle experiences sufficient sideways motion or deformation, or a certain likelihood of rollover.

DISPOSING OF AIRBAGS

Contact your authorized dealer as soon as possible. Airbags must be disposed of by qualified personnel.

911 Assist - Vehicles With: Emergency Assistance

WHAT IS 911 ASSIST

911 Assist is a feature that can call for help.

For more information, visit www.owner.ford.com.

HOW DOES 911 ASSIST WORK

If a crash deploys an airbag, excluding knee airbags and rear inflatable seatbelts, or activates the fuel pump shut-off, your vehicle may be able to contact emergency services by dialing 911 through a paired and connected **Bluetooth®** enabled phone.

Not all crashes deploy an airbag or activate the fuel pump shut-off. If a connected cell phone sustains damage or loses its connection to the operating system during a crash, the system searches for and tries to connect to a previously paired cell phone. The 911 Assist feature attempts to call the emergency services.

Before making the call:

- 911 Assist feature provides about 10 seconds to cancel the call. If you fail to cancel the call, the system attempts to dial 911.
- 911 Assist says the following, or a similar message: the system will attempt to call 911, to cancel the call, press Cancel on your screen or press and hold the phone button on your steering wheel.

If you do not cancel the call, 911 Assist makes a successful call a pre-recorded message plays for the 911 operator. The occupants in your vehicle are able to talk with the operator. Be prepared to provide your name, phone number and location immediately because not all 911 systems are capable of receiving this information electronically.

During an emergency call the system transmits vehicle data to the emergency service.

EMERGENCY CALL REQUIREMENTS



WARNING: Do not wait for 911 Assist to make an emergency call if you can do it yourself. Dial emergency services immediately to avoid delayed response time which could increase the risk of serious injury or death after a crash. If you do not hear 911 Assist within five seconds of the crash, the system or phone may be damaged or non-functional.



WARNING: Always place your phone in a secure location in your vehicle so it does not become a projectile or get damaged in a crash. Failure to do so may cause serious injury to someone or damage the phone which could prevent 911 Assist from working properly.



WARNING: Unless the 911 Assist setting is set on before a crash, the system will not dial for help which could delay response time, potentially increasing the risk of serious injury or death after a crash.

911 Assist - Vehicles With: Emergency Assistance

- The operating system must be powered and working properly at the time of the incident and throughout feature activation and use.
- The 911 Assist feature must be set on before the incident.
- You must pair and connect a **Bluetooth®** enabled and compatible cell phone to the operating system.
- A connected **Bluetooth®** enabled phone must have the ability to make and maintain an outgoing call at the time of the incident.
- A connected **Bluetooth®** enabled phone must have adequate network coverage, battery power and signal strength.
- The vehicle must have battery power and be located in the U.S., Canada or in a territory in which 911 is the emergency number.

Note: *If any user sets 911 Assist to on or off, that setting applies for all paired phones. If 911 Assist is switched off and the phone is connected to the operating system, an icon displays on the status bar.*

Note: *Every phone operates differently. While 911 Assist works with most cellular phones, some may have trouble using this feature.*

EMERGENCY CALL LIMITATIONS

The 911 Assist feature only operates in the U.S., Canada or in a territory in which 911 is the emergency number.

This feature does not operate properly if:

- Your cellular phone or 911 Assist hardware sustains damage in a crash.
- The vehicle's battery or the operating system has no power.
- The phone(s) thrown from your vehicle are the ones paired and connected to the system.

Keys and Remote Controls

REMOTE CONTROL LIMITATIONS

 **WARNING:** Changes or modifications not expressly approved by the party responsible for compliance could void the user's authority to operate the equipment. The term "IC:" before the radio certification number only signifies that Industry Canada technical specifications were met.

This device complies with Part 15 of the FCC Rules and with Industry Canada license-exempt RSS standard(s). Operation is subject to the following two conditions: (1) This device may not cause harmful interference, and (2) This device must accept any interference received, including interference that may cause undesired operation.

Make sure a valid remote control is within 3 ft (1 m) from the front door handles and rear of vehicle.

The system may not function if:

- The remote control remains stationary for about a minute.
- The vehicle battery has no charge.
- The remote control battery has no charge.

- There is interference causing issues with the remote control frequencies.
- The remote control is too close to metal objects or electronic devices, for example keys or a cell phone.

USING THE REMOTE CONTROL

 **WARNING:** Do not leave a key or remote control unattended in the vehicle. Children or pets could operate the power windows, moonroof or other controls. Failure to follow this instruction could result in personal injury or death.

Use your remote control to access various vehicle systems.

Note: *The buttons on your remote may vary depending on the vehicle region or options.*

Unlock

 Press the button to unlock all doors. See **Unlocking and Locking the Doors Using the Remote Control** (page 73).

Lock

 Press the button to lock all doors. See **Unlocking and Locking the Doors Using the Remote Control** (page 73).

Remote Start

 Press the button twice within three seconds to remote start. See **Starting a Gasoline Engine** (page 174).

Opening and Closing the Splitgate

 Press the button twice within three seconds to open and close the splitgate. See **Opening and Closing the Splitgate** (page 82).

Panic Alarm

 Press the button to sound the panic alarm. See **Sounding the Panic Alarm** (page 65).

Keys and Remote Controls

REMOVING THE KEY BLADE



Push the release button on your passive key and pull the key blade out.

SOUNDING THE PANIC ALARM



Press the button to sound the panic alarm. Press the button again or switch the ignition on to turn it off.

Note: *The panic alarm only operates when the ignition is off.*

LOCATING YOUR VEHICLE



Press the lock button twice within three seconds. The turn signal lamps flash. We recommend you use this method to locate your vehicle.

CHANGING THE REMOTE CONTROL BATTERY



WARNING: Keep batteries away from children to prevent ingestion. Failure to follow this instruction could result in personal injury or death. If ingested, immediately seek medical attention.



WARNING: If the battery compartment does not securely close, stop using the remote control and replace it as soon as possible. In the meantime, keep the remote control away from children. Failure to follow this instruction could result in personal injury or death.

The remote control uses one coin-type 3-volt lithium battery CR2450 or equivalent.



1. Push the release button and pull the key blade out.

Keys and Remote Controls

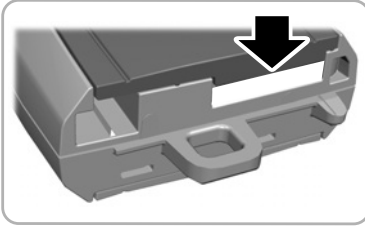

2. Twist a thin coin under the tab hidden behind the key blade head to remove the battery cover.

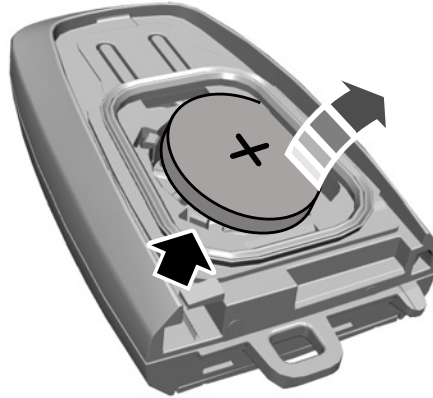

3. Insert a screwdriver, and carefully remove the battery.
4. Install a new battery with the + facing upward.
5. Reinstall the battery housing cover onto the transmitter and install the key blade.



Dispose of old batteries in an environmentally friendly way. Seek advice from your local authority about recycling old batteries.

Note: Do not wipe off any grease on the battery terminals or on the back surface of the circuit board.

Note: Replacing the battery does not erase the programmed key from your vehicle. The remote control should operate normally.

REPLACING A LOST KEY OR REMOTE CONTROL

You can purchase replacement keys or remote controls from an authorized dealer. Authorized dealers can program remote controls for your vehicle.

PROGRAMMING THE REMOTE CONTROL

Note: You can program a maximum of four remote controls to your vehicle.

Note: If your programmed remote controls are lost or stolen and you do not have an extra coded remote, you need to have your vehicle towed to an authorized dealer. Store an extra programmed remote away from your vehicle in a safe place to help prevent any inconvenience. Contact an authorized dealer to purchase additional spare or replacement remotes.

Keys and Remote Controls

You must have two previously programmed remote controls inside your vehicle and the new unprogrammed remote controls readily accessible. Contact an authorized dealer to have the spare remote control programmed if two previously programmed remotes are not available. Make sure that your vehicle is off before beginning this procedure. Make sure that you close all the doors before beginning and that they remain closed throughout the procedure. Perform all steps within 30 seconds of starting the sequence. Stop and wait for at least one minute before starting again if you perform any steps out of sequence.

Read and understand the entire procedure before you begin.

1. Place the first programmed remote in the backup slot inside the center console, with your foot off the brake pedal press and release the push button ignition switch. See **Accessing the Passive Key Backup Position** (page 176).

2. Wait five seconds and then press and release the push button ignition switch again.
3. Remove the remote control.
4. Within 10 seconds, place a second programmed remote control in the backup slot. Press and release the push button ignition switch.
5. Wait five seconds and then press and release the push button ignition switch again. Keep the ignition on for at least three seconds, but no more than 10 seconds.
6. Remove the remote control.
7. Place the unprogrammed remote control in the backup slot and press and release the push button ignition switch.

Programming is now complete. With your foot on the brake pedal, press the push button ignition switch to verify the remote control functions operate and your vehicle starts with the new remote control.

If programming was not successful, wait 10 seconds and repeat Steps 1 through 7. If you are still unsuccessful, take your vehicle to an authorized dealer.

KEYS AND REMOTE CONTROLS AUDIBLE WARNINGS

Key In Reminder

Sounds when the following conditions are met:

- Vehicle is out of park (P).
- You switch the vehicle off.
- You open the driver's door.
- You have left the key inside the vehicle.

Keys and Remote Controls

KEYS AND REMOTE CONTROLS – TROUBLESHOOTING

KEYS AND REMOTE CONTROLS – INFORMATION MESSAGES

Message	Action
Key Battery Low Replace Soon	Replace remote control battery.

Phone as a Key (If Equipped)

WHAT IS PHONE AS A KEY

Phone as a Key allows you to use your phone in place of a passive key.

You can use your phone for the following functions:

- Remote locking and unlocking.
- Passive entry and exit.
- Passive start and drive the vehicle.
- Remote start.
- Memory function recall.

PHONE AS A KEY LIMITATIONS

Limitations can vary based on the make and model of your phone, phone location and physical obstructions.

The following items could impact Phone as a Key performance or prevent functionality in some cases:

- The typical operating range for Phone as a Key is 131 ft (40 m).
- Your **Bluetooth**® connection is not enabled, is disrupted, or out of range.
- Phone as a Key is not active or enabled on at least one phone.

- Your vehicle battery has depleted.
- Your phone battery has depleted.
- Interference from other devices using radio frequencies or physical obstructions.
- Your phone is too close to metal objects or other electronic devices.

Note: *Do not leave a duplicate coded key in the vehicle. Always take your keys and phone and lock all doors when leaving the vehicle.*

PROGRAMMING YOUR PHONE

To program your device as Phone as a Key:

1. Visit your device's app store to download the Ford mobile app.
2. Create a new account or sign in to an existing account on the Ford mobile app.
3. Add the vehicle identification number to your account and follow the prompts in the Ford mobile app to complete the authorization process.
4. After the authorization is complete, you can set up Phone as a Key following the prompts in the Ford mobile app.

5. After Phone as a Key is set up, you can set up the backup start passcode by following the prompts on your touchscreen.

Note: *Keep your new backup start passcode with you in case of an emergency.*

Resetting Phone as a Key

To reset Phone as a Key from your vehicle See **Performing a System Reset** (page 485).

USING THE VALET MODE

Classic Valet Mode

Enabling Valet Mode

Make sure the remote control is in your vehicle.

1. From the controls menu, press Valet Mode.
2. Enter a four digit code to lock the touchscreen.
3. Reenter the same four digit code to complete enabling valet mode.

Disabling Valet Mode

1. Press Exit Valet Mode.

Phone as a Key (If Equipped)

2. Enter your four digit code to disable valet mode and unlock your touchscreen.

Enhanced Valet Mode

Enabling Valet Mode

Have your backup start passcode completely set up before using valet mode. See **Programming Your Phone** (page 69).

Note: If your vehicle detects a remote control, the system defaults to classic valet mode.

1. From the controls menu, press Valet Mode.

Note: If the system detects a valid Phone as a Key, a valet passcode displays on both the touchscreen and mobile app.

Note: If the system does not detect a valid Phone as a Key, it prompts you to enter your backup start passcode on the touchscreen. Once validated, a valet passcode displays on the touchscreen.

2. Provide the valet the first five digits of the valet passcode to enter on the keyless entry keypad to unlock your vehicle.
3. Provide the valet the eight-digit valet passcode to enter on the touchscreen to start and drive your vehicle.

Disabling Valet Mode

1. Press Exit Valet Mode.

Note: If the system detects a valid Phone as a Key, valet mode disables.

Note: If the system does not detect a valid Phone as a Key, it prompts you to enter your backup start passcode. Once validated, valet mode disables.

USING THE BACKUP START PASSCODE

Make sure you have Phone as a Key active on at least one phone to use the previously created backup start passcode. See **Programming Your Phone** (page 69).

1. Press the brake pedal and the push button ignition switch. If the system does not detect a valid Phone as a Key or remote control, a message appears on the touchscreen and the system prompts you for your backup start passcode.

Note: The touchscreen times out after 30 seconds with no interaction.

Note: If the backup start passcode screen does not appear, press the brake pedal and push button ignition switch again.

2. Use the touchscreen to enter your backup start passcode.
3. After entering your backup start passcode, press return within 30 seconds.
4. Once the system validates the backup start passcode, a message alerts you to start your vehicle.
5. Press the brake pedal and the push button ignition switch within 20 seconds to start the vehicle.
6. If your vehicle does not start, repeat steps 1-5.

System Lockout

The system locks after five combined incorrect attempts of the following:

- Entering a backup start passcode.
- Resetting a current passcode.
- Entering a valet mode passcode.

Note: The system remains locked for a short period of time. After that the system allows passcodes to be entered again.

Phone as a Key (If Equipped)

PHONE AS A KEY – TROUBLESHOOTING

PHONE AS A KEY – FREQUENTLY ASKED QUESTIONS

How can I tell if my vehicle has Phone as a Key?

- The vehicle's touchscreen shows the Phone as a Key reset option.
- Additional control buttons appear on the home screen of the Ford mobile app if you have already set up Phone as a Key on your vehicle through the Ford mobile app.

What happens if I cannot unlock the vehicle with Phone as a Key?

- Attempt to move your phone closer to the vehicle.
- Check that the Ford mobile app is still running and that the Phone as a Key control screen shows **Bluetooth®** is connected. If the phone is connected, attempt to press the remote unlock button in the Ford mobile app. If the phone is not connected or the remote unlock button does not work in the Ford mobile app, attempt to force close and restart the app.

Why do I get a **No Key Detected** message in the instrument cluster display when I am using Phone as a Key and my phone is in the car?

- Your phone's **Bluetooth®** connection has been disrupted or is not connected. Try reconnecting your phone's **Bluetooth®** connection.
- Move the phone closer to the center of the vehicle near the cup holder or center console.
- Verify Phone as a Key is still active, enabled and has not been revoked.

What do I do if my phone is lost, damaged or the battery has depleted?

- Use the backup start passcode that you created. See **Using the Backup Start Passcode** (page 70).

How many phones can I use for Phone as a Key?

- You can program and activate up to four phones with Phone as a Key to control your vehicle.

How does a valet drive my car if I only use Phone as a Key?

- Have the valet use the temporary valet passcode that you created. See **Using the Valet Mode** (page 69).

I uninstalled my Ford mobile app and reinstalled it. Why am I not able to set up Phone as a Key again?

- Using the key list in the Ford mobile app remove the key that was previously associated with your phone.
- Reset Phone as a Key from your vehicle, and then set up Phone as a Key again. See **Programming Your Phone** (page 69).

Phone as a Key (If Equipped)

Why can I not remotely start the vehicle with Phone as a Key?

- Using the Ford mobile app, verify your Phone as a Key setup is complete and **Bluetooth®** is connected on at least one phone. If Phone as a Key setup is not complete, complete the setup as prompted from the Ford mobile app. See **Programming Your Phone** (page 69).

Doors and Locks

OPERATING THE DOORS FROM OUTSIDE YOUR VEHICLE

UNLOCKING AND LOCKING THE DOORS USING THE REMOTE CONTROL

You can only use the remote control when your vehicle is stationary.

Unlocking the Doors



Press the button to unlock all doors. One long flash of the turn signal lamps confirms that your vehicle has unlocked.

Locking the Doors



Press the button to lock all doors. One short flash of the turn signal lamps confirms that your vehicle has locked.

UNLOCKING AND LOCKING THE DOORS USING THE KEY BLADE

If there is a power door lock fault you can use the key blade to lock and unlock the doors.

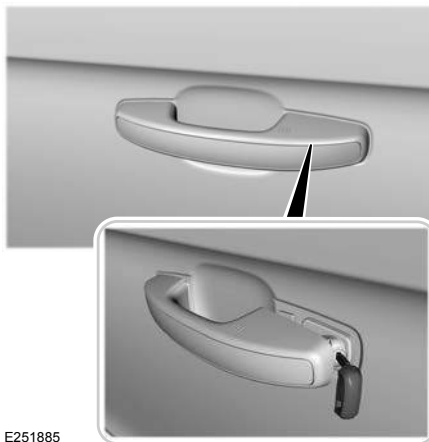

E251885

Turn clockwise to lock.

Turn counterclockwise to unlock.

OPERATING THE DOORS FROM INSIDE YOUR VEHICLE

UNLOCKING AND LOCKING THE DOORS USING THE CENTRAL LOCKING

The power door lock control is on the front doors.



Press the button to unlock all doors.



Press the button to lock all doors.

Note: The central locking only operates if the front doors are fully closed.

OPENING THE DOORS FROM INSIDE YOUR VEHICLE

Pull the interior door handle twice to unlock and open a rear door. The first pull unlocks the door and the second pull opens the door.

Doors and Locks

AUTOUNLOCK

WHAT IS AUTOUNLOCK

Autounlock is a feature that centrally unlocks the vehicle doors when your vehicle comes to a stop and you open the driver door.

AUTOUNLOCK REQUIREMENTS

Autounlock unlocks all the doors after:

1. The vehicle speed exceeds 12 mph (20 km/h).
2. Your vehicle comes to a stop.
3. You open the driver door.

Note: *Autounlock operates for only 10 minutes after the ignition is switched off.*

SWITCHING AUTOUNLOCK ON AND OFF

1. From the settings menu, press Vehicle.
2. Press Locks.
3. Switch Autounlock on or off.

AUTOLOCK (IF EQUIPPED)

WHAT IS AUTOLOCK

Autolock is a locking feature that centrally locks your vehicle doors when driving.

AUTOLOCK REQUIREMENTS

Autolock locks all the doors after:

1. All doors are closed and the ignition is on.
2. Your vehicle speed exceeds 12 mph (20 km/h).

Autolock repeats if:

1. Your vehicle is stopped.
2. Any door is opened and closed again.
3. Your vehicle speed exceeds 12 mph (20 km/h).

SWITCHING AUTOLOCK ON AND OFF

1. From the settings menu, press Vehicle.
2. Press Locks.
3. Switch Autolock on or off.

MISLOCK

WHAT IS MISLOCK

Mislock is a locking feature that warns you if your vehicle has not locked.

MISLOCK LIMITATIONS

When you press the lock button once, the turn signals do not flash if:

- Any door or the tailgate is open.
- The hood is open.

If you switch mislock off, the horn does not sound if you press the lock button on the remote control when a door is open.

SWITCHING MISLOCK ON AND OFF

1. From the settings menu, press Vehicle.
2. Press Locks.
3. Switch Mislock chirp on or off.

Doors and Locks

DOORS AND LOCKS AUDIBLE WARNINGS

Door Ajar Audible Warning

Sounds when any front door is not fully closed and your vehicle is moving.

DOORS AND LOCKS – TROUBLESHOOTING

DOORS AND LOCKS – WARNING LAMPS

Door Ajar Warning Lamp



Illuminates when you switch the ignition on and remains on if any door or the hood is open.

DOORS AND LOCKS – INFORMATION MESSAGES

Message	Details
Driver Door Ajar	Displays if a door is open. Fully close the door.
Passenger Door Ajar	
Rear Left Door Ajar	
Rear Right Door Ajar	
Hood Ajar	Displays if a hood is open. Fully close the hood.

Keyless Entry

WHAT IS KEYLESS ENTRY

The system allows you to lock and unlock your vehicle without taking the passive key out of your pocket or purse.

KEYLESS ENTRY LIMITATIONS

Make sure your remote control is within 3 ft (1 m) from the front door handles and the splitgate.

The system could not function if:

- The remote control remains stationary for about a minute.
- The vehicle battery has no charge.
- The remote control battery has no charge.
- There is interference causing issues with the remote control frequencies.
- The remote control is too close to metal objects or electronic devices, for example keys or a cell phone.

KEYLESS ENTRY SETTINGS

Reprogramming the Unlocking Function (If Equipped)

You can enable the two-stage unlocking function allowing you to unlock only the driver door when you touch the unlock sensor.

Press and hold both the lock and unlock buttons on the remote control for four seconds to disable or enable two-stage unlocking.

If you program the unlocking function so that only the driver door unlocks, you can unlock all of the other doors from inside your vehicle using the power door lock control. You can unlock individual doors by pulling the interior door handles on those doors.

Key Detection Alert

Displays a message in the instrument cluster if no valid key is detected, when you exit your vehicle with a key, after the last front door is closed and your keyless vehicle is in run, indicating your vehicle is still on. An audible alert sounds if you have driven the vehicle and reached a speed of 16 mph (25 km/h) and the above mentioned conditions are met.

You can switch the audible alert on or off.

1. From the settings menu, press Vehicle.
2. Switch Key Detection Alert On or Off.

USING KEYLESS ENTRY

Unlocking the Doors



With your passive key within 3 ft (1 m) of your vehicle, touch the unlock sensor on the back of the door handle for a brief period and then pull on the door handle to unlock, being careful not to touch the lock sensor at the same time or pull on the door handle too quickly. The intelligent access system requires a brief delay to authenticate your intelligent access key.

Keyless Entry

Using the Power Splitgate with Passive Key

With your passive key within 3 ft (1 m) of your vehicle, press the exterior liftgate release button to unlock and open liftgate. Then press the tailgate control button to open the tailgate. See **Opening and Closing the Splitgate** (page 82).

Locking the Doors



With your passive key within 3 ft (1 m) of your vehicle, touch the outer door handle lock sensor for approximately one second to lock, being careful not to touch the unlock sensor on the back of the door handle at the same time. After locking, you can immediately pull on the door handle to confirm locking occurred without inadvertently unlocking.

KEYLESS ENTRY – TROUBLESHOOTING

KEYLESS ENTRY – FREQUENTLY ASKED QUESTIONS

Why does the keyless entry system not function?

If the system does not function it may be limited. See **Keyless Entry Limitations** (page 76). If the system still does not function use the remote control or the key blade to lock and unlock your vehicle.

Why can I not lock my vehicle?

If you electronically lock your vehicle with a rear door or the liftgate open, the system searches for a passive key inside your vehicle after you close the last door. If the system detects a key, all doors unlock indicating that a key is inside. Your vehicle locks if another passive key is within the detection range after you close the last door.

Keyless Entry Keypad

WHAT IS THE KEYLESS ENTRY KEYPAD

The keyless entry keypad allows you to lock and unlock your vehicle using the keypad on the window trim.

Note: *The keypad uses either a five-digit or a seven-digit access code. You can view the master access code in the instrument cluster display to find the type of the code in your vehicle. See **Keyless Entry Keypad Master Access Code** (page 78).*

KEYLESS ENTRY KEYPAD LIMITATIONS

The system may not function if:

- The vehicle battery has no charge.

LOCATING THE KEYLESS ENTRY KEYPAD

The keypad is near the driver window and illuminates when you touch it.

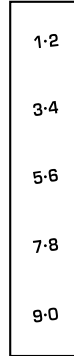

KEYLESS ENTRY KEYPAD MASTER ACCESS CODE

What is the Master Access Code

The master access code is a factory-set entry code. You can operate the keypad with the master access code at any time. The master access code can be displayed in the instrument cluster display.

Displaying the Master Access Code in the Instrument Cluster Display

Read and understand the following before you begin the process.

- You must have two keys inside your vehicle.
- Make sure that you close all the doors and that they remain closed throughout the procedure.
- Do not place the device on the wireless accessory charging area during the procedure.

Note: *Perform all steps within 30 seconds of starting the sequence. If you perform any of the steps out of sequence, stop and wait for at least one minute before starting again.*

1. Turn the vehicle off.
2. Place the first key into the backup slot.
3. Turn on the vehicle, without pressing the brake pedal, and wait for a few seconds.
4. Turn off the vehicle and replace the first key with the second key.
5. Turn on the vehicle, without pressing the brake pedal.

The master access code appears in the instrument cluster display for a few seconds.

Keyless Entry Keypad

Note: The code may not display until after other warning messages display.

KEYLESS ENTRY KEYPAD PERSONAL ACCESS CODES

Programming a Personal Entry Code

1. Enter your master access code.
2. Press **1-2** on the keypad within five seconds.
3. Enter your personal access code. You must do this within five seconds of completing Step 2.

Note: The personal access code must have the same number of digits as your master access code. See **Keyless Entry Keypad Master Access Code** (page 78).

4. Press **1-2** on the keypad to save personal code 1.

The doors lock then unlock to confirm that programming was successful.

To program additional personal entry codes, repeat Steps 1 through 3, then for Step 4:

- Press **3-4** to save personal code 2.
- Press **5-6** to save personal code 3.

- Press **7-8** to save personal code 4.
- Press **9-0** to save personal code 5.

If your vehicle comes with the operating system, you can also program the system with one personal entry code.

Note: Programming a code using the operating system overwrites any code that was already saved on the position 9-0 of the keypad.

Hints:

- Do not use the same number for all the digits in the code.
- Do not use the numbers in sequential order.
- The master access code works even if you have set your own personal code.

Erasing a Personal Code

1. Enter the master access code.
2. Press and release **1-2** on the keypad within five seconds.
3. Press and hold **1-2** for two seconds. You must do this within five seconds of completing Step 2.

All personal codes erase and only the master access code works.

Anti-Scan Feature

The keypad goes into an anti-scan mode if you enter the wrong code seven times. This mode turns off the keypad for one minute and the keypad lamp flashes.

The anti-scan feature turns off after:

- One minute of keypad inactivity.
- You press the unlock button on the remote control.
- You switch the ignition on.
- You unlock your vehicle using keyless entry.

Keyless Entry Keypad

USING THE KEYLESS ENTRY KEYPAD

Unlocking the Driver Door

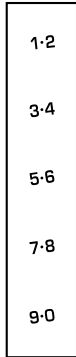

Enter the master access code or your personal access code. You must press each number within five seconds of each other.

Note: All doors unlock if the two-stage unlocking feature is disabled. See **Keyless Entry Settings** (page 76).

Unlocking All Doors

Enter the factory-set code or your personal code, then press **3-4** within five seconds.

Locking the Doors

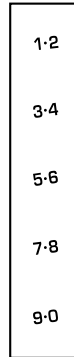

Press and hold **7-8** and **9-0** at the same time with the driver door closed.

Note: You do not need to enter the code first.

KEYLESS ENTRY KEYPAD – TROUBLESHOOTING

KEYLESS ENTRY KEYPAD – FREQUENTLY ASKED QUESTIONS

Why does the keypad not accept the access code?

- If you enter the access code too fast on the keypad, the unlock function may not work. Slowly re-enter the access code.

Why does the keypad not function?

- The keypad goes into an anti-scan mode if you enter a wrong code seven times. The anti-scan mode disables the keypad for one minute and the red light flashes.

Easy Entry and Exit

HOW DOES EASY ENTRY AND EXIT WORK

Easy entry and exit moves the driver seat rearward and the steering column up when you switch the ignition off. The driver seat and steering column return to their previous positions when you switch the ignition on.

Note: *Depending on your vehicle, the column may move up and in.*

SWITCHING EASY ENTRY AND EXIT ON AND OFF

1. From the settings menu, press Vehicle.
2. Press Easy Entry/Exit.

If you press any adjustment button when in easy exit mode, the system cancels the operation.

Splitgate

OPENING AND CLOSING THE SPLITGATE

 **WARNING:** It is extremely dangerous to ride in a cargo area, inside or outside of a vehicle. In a crash, people riding in these areas are more likely to be seriously injured or killed. Do not allow people to ride in any area of your vehicle that is not equipped with seats and seatbelts. Make sure everyone in your vehicle is in a seat and properly using a seatbelt. Failure to follow this warning could result in serious personal injury or death.

 **WARNING:** Make sure that you fully close the splitgate to prevent exhaust fumes from entering your vehicle. If you are unable to fully close the splitgate, open the air vents or the windows to allow fresh air to enter your vehicle. Failure to follow this instruction could result in personal injury or death.

 **WARNING:** Keep keys or remote control out of reach of children. Do not allow children to operate or play near an open or moving power splitgate. You should supervise the operation of the power splitgate at all times.

Note: Be careful when opening or closing the splitgate in a garage or other enclosed area to avoid damaging the splitgate.

Note: Do not hang anything, for example a bike rack, from the glass or splitgate. This could damage the splitgate and its components.

Note: Do not leave the splitgate open while driving. This could damage the splitgate and its components.

Opening the Splitgate

 **WARNING:** Make sure all persons are clear of the power splitgate area before opening or closing the splitgate.

Opening the Splitgate from Inside Your Vehicle

Opening the splitgate using the instrument panel button



With the transmission in park (P), press the button on the instrument panel to open both liftgate and tailgate.

Opening the splitgate using the touchscreen

1. Press to open the controls screen.



2. Press the button to open both liftgate and tailgate.

Opening the Splitgate From Outside Your Vehicle

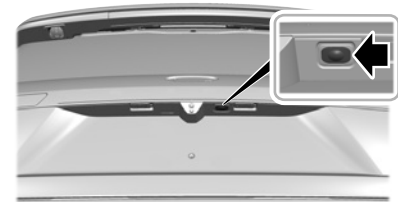

Splitgate

Press the liftgate button to access the tailgate control button.

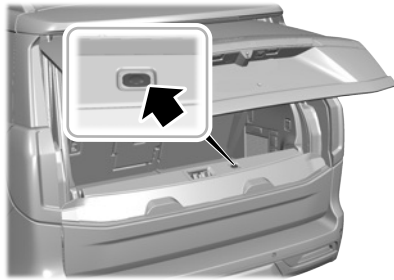

Press the control button to open the tailgate.

Opening the Splitgate Using the Remote Control



Press the button twice within three seconds to open both the liftgate and tailgate.

Closing the Splitgate



WARNING: Make sure all persons are clear of the power splitgate area before opening or closing the splitgate.

Note: Make sure that you fully close the splitgate to prevent cargo from falling out.

Note: The splitgate does not close if the vehicle speed is at or above 2.5 mph (4 km/h).

Closing the Splitgate from Inside Your Vehicle

Closing the splitgate using the instrument panel button



With the transmission in park (P), press the button on the instrument panel to close both the liftgate and tailgate.

Closing the splitgate using the touchscreen

1. Press to open the controls screen.



2. Press the button to close both the liftgate and tailgate.

Closing the Splitgate Using the Remote Control



Press the button twice within three seconds to close both the liftgate and tailgate.

OPENING THE OPEN ON APPROACH SPLITGATE

You can open both the liftgate and tailgate using your passive key if the following conditions are met



A	Dwell Zone
---	------------

- The passive key is within 3 ft (1 m) behind the vehicle for approximately 4 seconds.
- The vehicle is turned off or remotely started or in park (P) and locked.
- The vehicle is not in towing, valet or transport modes.

Note: Before the splitgate opens, the hazard warning lamps flash and a tone sounds.

Note: Do not leave the splitgate open while driving. This could damage the splitgate and its components.

Splitgate

OPEN ON APPROACH SETTINGS

Switching Open On Approach on and off

1. From the settings menu, press Vehicle.
2. Press Splitgate.
3. Press Power Splitgate
4. You can switch the Open On Approach on or off on your touchscreen.

Keyfob and Open on Approach Configuration

You can set the remote control to open either the liftgate only or the liftgate and tailgate, through the touchscreen.

1. From the settings menu, press Vehicle.
2. Press Splitgate.
3. Press Power Splitgate
4. Press Keyfob and Open on Approach.

SPLITGATE SETTINGS

1. From the settings menu, press vehicle.
2. Press Splitgate.
3. You can switch the power splitgate on or off on your touchscreen.

Note: When switched off, the splitgate only unlatches and does not power open or close.

OPENING AND CLOSING THE LIFTGATE



WARNING: It is extremely dangerous to ride in a cargo area, inside or outside of a vehicle. In a crash, people riding in these areas are more likely to be seriously injured or killed. Do not allow people to ride in any area of your vehicle that is not equipped with seats and seatbelts. Make sure everyone in your vehicle is in a seat and properly using a seatbelt. Failure to follow this warning could result in serious personal injury or death.



WARNING: Make sure that you fully close the liftgate to prevent exhaust fumes from entering your vehicle. If you are unable to fully close the liftgate, open the air vents or the windows to allow fresh air to enter your vehicle. Failure to follow this instruction could result in personal injury or death.



WARNING: Keep keys out of reach of children. Do not allow children to operate or play near an open or moving power liftgate. You should supervise the operation of the power liftgate at all times.

Note: Make sure the area behind your vehicle is free from obstruction and that there is enough room for you to operate the liftgate. Make sure that you close the liftgate before operating or moving your vehicle, especially in an enclosure like a garage or a parking structure. This could damage the liftgate and its components.

Note: Be careful when opening or closing the liftgate in a garage or other enclosed area to avoid damaging the liftgate.

Note: Do not hang anything, for example a bike rack, from the glass or liftgate. This could damage the liftgate and its components.

Opening the Liftgate



WARNING: Make sure all persons are clear of the power liftgate area before opening or closing the liftgate.

Splitgate

Note: Do not leave the liftgate open while driving. This could damage the liftgate and its components.

Opening the Liftgate from Inside your Vehicle

Opening the liftgate using the instrument panel button



With the transmission in park (P), press the button on the instrument panel.

Opening the liftgate using the touchscreen

1. Press to open the controls screen.
- 2.



Press the button to open the liftgate.

Opening the Liftgate From Outside Your Vehicle

1. Unlock the liftgate with the remote control or power door unlock control. If a passive key is within 3 ft (1 m) of the liftgate, the liftgate unlocks when you press the liftgate release button.



2. Press and release the liftgate control button.

Note: Allow the power system to open the liftgate. Manually pushing or pulling the liftgate could activate the system's obstacle detection feature and stop the power operation or reverse its direction, replicate a strut failure, or damage mechanical components.

Opening the Liftgate Using the Remote Control



Press the button twice within three seconds.

Closing the Liftgate



WARNING: Make sure all persons are clear of the power liftgate area before opening or closing the liftgate.

Note: Make sure that you close the liftgate before operating or moving your vehicle, especially in an enclosure like a garage or a parking structure. This could damage the liftgate and its components.

Closing the Liftgate From Inside Your Vehicle

Closing the liftgate using the instrument panel button



With the transmission in park (P), press the button on the instrument panel.

Closing the liftgate using the touchscreen

1. Press to open the controls screen.
- 2.



Press the button to open the liftgate.

Splitgate

Closing the Liftgate From Outside Your Vehicle

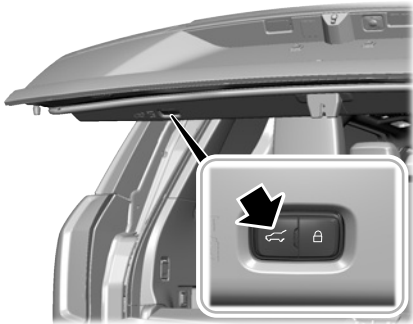

Press the liftgate button.

Closing the Liftgate Using the Remote Control



Press the button twice within three seconds. A tone sounds when the liftgate begins to close.

Note: The tailgate also closes along with the liftgate if the tailgate is ajar.

LIFTGATE SETTINGS

Switching the Power Liftgate On or Off

1. From the settings menu, press vehicle.
2. Press liftgate.
3. You can switch the power liftgate on or off on your touchscreen.

Note: When switched off, the liftgate only unlatches and does not power open or close.

Setting the Liftgate Opening Height

1. Open the liftgate.
2. Stop the liftgate movement by pressing the control button on the liftgate when it reaches the desired height.
3. Press and hold the control button on the liftgate until a tone sounds, indicating programming is complete.

Note: Once the liftgate stops moving, you can manually move it to the desired height.

Note: You can only use the liftgate control button to program the height.

Note: You cannot program the height if the liftgate position is too low.

4. The power liftgate now opens at the programmed height. To change the programmed height, repeat the steps.

Note: You can fully open the liftgate by manually pushing it upward to the maximum open position if it opens in a lower position.

Note: The system recalls the new programmed height until you reprogram it, even if you disconnect the battery.

Liftgate Obstacle Detection

Opening and Closing the Liftgate

The system stops and a tone sounds when the liftgate detects an obstacle. Once you remove the obstacle, you can continue to operate the liftgate.

Note: To prevent accidental obstacle detection, let the power liftgate close completely before you enter your vehicle.

Splitgate

OPENING AND CLOSING THE TAILGATE

Opening the Tailgate from Outside Your Vehicle

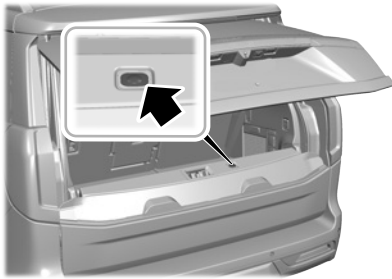

1. Press the liftgate button to access the tailgate control button.
2. Press the control button to open the tailgate.

Note: You may need to unlock the liftgate first.

Note: Allow the power system to open the tailgate. Manually pushing or pulling the tailgate could activate the system's obstacle detection feature and stop the power operation or reverse its direction, replicate a strut failure, or damage mechanical components.

Closing the Tailgate from Outside Your Vehicle

You can close the tailgate by pressing the control button.

TAILGATE SETTINGS

Tailgate Obstacle Detection

The system stops and a tone sounds when the tailgate detects an obstacle. Once you remove the obstacle, you can continue to operate the tailgate.

Note: To prevent accidental obstacle detection, let the power tailgate close before you enter your vehicle.

SPLITGATE – TROUBLESHOOTING

SPLITGATE – WARNING LAMPS



Illuminates when the liftgate is not completely closed.



Illuminates when the liftgate glass is not completely closed.



Illuminates when the splitgate is not completely closed.

Splitgate

SPLITGATE – INFORMATION MESSAGES

Message	Action
Liftgate Ajar	The liftgate is not completely closed. Close the liftgate.
Liftgate and Tailgate Ajar	The liftgate and tailgate are not completely closed.

Splitgate

SPLITGATE – FREQUENTLY ASKED QUESTIONS

Why won't my power splitgate open?

Make sure the splitgate is in power mode. Make sure the transmission is in park (P), make sure nothing is obstructing the splitgate path or causing resistance (tonneau cover or other aftermarket accessory, freezing conditions or being parked downhill). If you have continued issues, the battery voltage may be low or other system issues. See an authorized dealer.

Why won't my power splitgate close?

Make sure the splitgate is in power mode. Your vehicle speed is at or above 2.5 mph (4 km/h), the splitgate encountered an obstacle or freezing conditions. After removing the obstacles, manually close the tailgate to resume normal operation. If you have continued issues, the battery voltage may be low or other system issues. See an authorized dealer.

Why won't my power liftgate function?

It can happen in freezing conditions or when parking on downhill slopes. Make sure the power liftgate is enabled. Make sure the transmission is in park (P), make sure nothing is obstructing the liftgate path and there is not excessive weight on the liftgate. If there are continued issues, the battery voltage may be low or there may be other system issues. See an authorized dealer.

Security

PASSIVE ANTI-THEFT SYSTEM

WHAT IS THE PASSIVE ANTI-THEFT SYSTEM

The passive anti-theft system prevents someone from starting your vehicle with an incorrectly coded key.

Note: *Do not leave a duplicate coded key in your vehicle. Always take the keys and lock all the doors when leaving your vehicle.*

HOW DOES THE PASSIVE ANTI-THEFT SYSTEM WORK

The passive anti-theft system arms when you switch your vehicle off.

It disarms when you switch your vehicle on with a correctly coded key.

Note: *The system is not compatible with non-Ford aftermarket remote start systems.*

Note: *Do not leave a duplicate coded key in your vehicle. Always take the keys and lock all doors when leaving your vehicle.*

ANTI-THEFT ALARM SYSTEM

WHAT IS THE ANTI-THEFT ALARM SYSTEM

The anti-theft alarm system warns you of an unauthorized entry to your vehicle.

HOW DOES THE ANTI-THEFT ALARM SYSTEM WORK

When armed, the anti-theft alarm is triggered in any of the following ways:

- Opening a door, the tailgate or hood without a correctly coded key or remote control.
- If you turn the power on without a correctly coded key.
- Disconnecting the battery.
- Disconnecting the trailer. See **Connecting a Trailer** (page 330).

Any further attempts to carry out one of the above, sounds the alarm again.

If the anti-theft alarm is triggered, the alarm horn sounds for 30 seconds and the turn signals flash for five minutes.

WHAT IS THE PERIMETER ALARM

The perimeter alarm is designed to detect unauthorized access to your vehicle.

ARMING THE ANTI-THEFT ALARM SYSTEM

The alarm is ready to arm when you switch your vehicle off.

Lock your vehicle with your remote control to arm the alarm.

DISARMING THE ANTI-THEFT ALARM SYSTEM

Disarm the alarm by performing any of the following actions:

- Unlock the doors or luggage compartment with the remote control.
- Switch your vehicle on or start your vehicle.

Security

SECURITY – TROUBLESHOOTING

SECURITY – INFORMATION MESSAGES

Message	Details
No Key Detected	The system has not detected a correctly coded key.
Starting System Fault	The system has malfunctioned. Have your vehicle checked as soon as possible.
Vehicle Alarm To Stop Alarm, Start Vehicle.	Displays when the alarm has been triggered due to unauthorized entry.
Alarm	

Security

SECURITY – FREQUENTLY ASKED QUESTIONS

What should I do if there is a potential alarm problem with my vehicle?

- Take all remote controls to an authorized dealer if there is a potential alarm problem with your vehicle.

What should I do if my vehicle is unable to start with a correctly coded key?

- Have your vehicle checked as soon as possible.

Power Running Boards (If Equipped)

POWER RUNNING BOARD PRECAUTIONS



WARNING: Do not step on a running board that is moving or not fully deployed. Failure to follow this instruction may result in personal injury.



WARNING: Switch off the running boards before jacking or placing any object under your vehicle. Failure to follow this instruction may result in personal injury or property damage.



WARNING: Never place your hands or feet near a moving running board. Failure to follow this instruction may cause personal injury.

Note: *The power running boards could be exposed to factors such as ice, mud, or rocks, causing the running boards to not deploy or stow properly. The power running boards resume normal operation once the mechanical device that allows movement of the running boards is cleaned and lubricated following the maintenance instructions.*

POWER RUNNING BOARD SETTINGS

1. From the settings menu, press Vehicle.
2. Press Power Running Board.
3. Press a setting.

Running Boards (Modes)

Note: *When the vehicle speed is more than 3 mph (5 km/h), the option to select the modes disables, to avoid unintended operation.*

Note: *The power running boards reverse direction and move to the end of travel if they encounter an object when moving. Keep the power running boards and brackets clean for optimum performance.*

Off

The power running boards remain stowed, regardless of door position.

Auto

The power running boards deploy when you unlock or open the door.

The power running boards stow if any of the following occur:

- After a few seconds when you close the doors.
- Instantly after you close and lock the doors.
- If you unlock the door but do not open it, after the time out.
- When the vehicle speed is more than 3 mph (5 km/h).

Note: *When you select this mode, an option displays that allows you to select how long the running boards stay deployed without opening the door.*

Out

The power running boards remain deployed, regardless of door position. The power running boards stow when the vehicle speed is more than 3 mph (5 km/h), and the mode changes to **Auto**. You need to select **Out** mode again if you want the power running boards to stay deployed at the end of each trip.

Power Running Boards (If Equipped)

POWER RUNNING BOARDS – TROUBLESHOOTING

POWER RUNNING BOARDS – FREQUENTLY ASKED QUESTIONS

Why are my power running boards not deploying and/or stowing as expected?

- The power running boards may produce unwanted noises, move in and out randomly, move slowly, or get stuck mid-travel when the power running boards mechanism has trapped debris such as mud, dirt, snow, ice, and/or salt. If this happens, follow the maintenance procedure below.

What maintenance should my power running boards have?

- Set the running boards to the deployed position by selecting the out mode. Wash the system, in particular the front and rear hinge arms, with a high-pressure car wash wand. Avoid using a wand that is not designed for car wash use, as excessive water pressure could damage nearby components.

- Apply Motorcraft penetrating and lock lubricant to clean the bushing locations on both running board hinges. This removes any embedded rust or debris that pressure washing may not have removed. If any leftover debris or rust is present after using the penetrating lubricant, use a pressure washer to remove it.
- To help prevent power running board deployment issues, use lithium grease to help keep debris away from the moving parts of the running board. Apply Motorcraft® multi-purpose grease on each bushing location and the motor output shaft.
- Remember to properly clean the power running boards every time you notice slow movement or improper behavior. Apply multi-purpose grease to the mechanism every 6 months.

Steering Wheel

USING THE CONTROLS ON THE STEERING WHEEL

WARNING: Driving while distracted can result in loss of vehicle control, crash and injury. We strongly recommend that you use extreme caution when using any device that may take your focus off the road. Your primary responsibility is the safe operation of your vehicle. We recommend

against the use of any hand-held device while driving and encourage the use of voice-operated systems when possible. Make sure you are aware of all applicable local laws that may affect the use of electronic devices while driving.

The steering wheel control has nine possible locations. When activated, a control mirror in the instrument cluster display reflects the available controls.

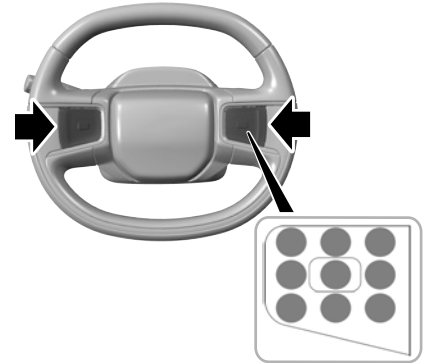

Instrument Cluster Display Control Mirror

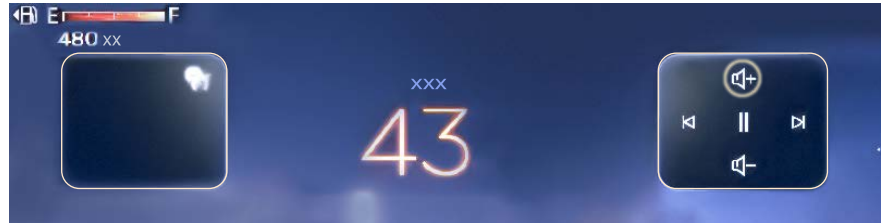

Steering Wheel

1. Press any area on the control to activate the control mirror in the instrument cluster display. The control mirror highlights the locations you press. Any applicable text of the active location appears below the control mirror in the instrument cluster display.

Note: Applicable text displays in the instrument cluster for right-hand controls only.

2. Using the control mirror, press the corresponding location on the steering wheel control to select the option you prefer.

Note: The instrument cluster display control mirror times out after a few seconds.

ADJUSTING THE STEERING WHEEL - VEHICLES WITH: MANUAL ADJUSTABLE STEERING COLUMN

 **WARNING:** Do not adjust the steering wheel when your vehicle is moving.

Note: Make sure that you are sitting in the correct position. See **Sitting in the Correct Position** (page 138).

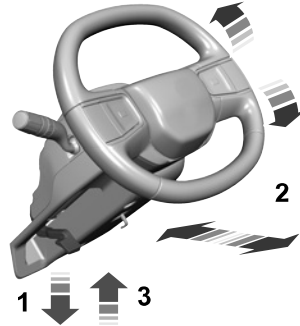

1. Unlock the steering column.
2. Adjust the steering wheel to the position you prefer.
3. Lock the steering column.

ADJUSTING THE STEERING WHEEL - VEHICLES WITH: POWER ADJUSTABLE STEERING COLUMN

 **WARNING:** Do not adjust the steering wheel when your vehicle is moving.

Note: Make sure that you are sitting in the correct position. See **Sitting in the Correct Position** (page 138).

The control is on the right-hand side of the steering wheel. See **Using the Controls on the Steering Wheel** (page 95).

1.  Using the controls on the steering wheel, press the driver adjustment menu.

Note: The available controls appear in the instrument cluster display.

2.  Press the button to access the steering wheel adjust option.

Steering Wheel

3.  Press the directional arrows to adjust the steering wheel.

You can save and recall the steering wheel position with the memory function. See **Using the Memory Function** (page 480).

RESETTING THE STOPPING POSITION - VEHICLES WITH: POWER ADJUSTABLE STEERING COLUMN

Note: The steering wheel stops when it detects an obstruction. This sets a new stopping position.

To reset the steering column to its normal stopping position:

1. Confirm there is nothing obstructing the motion of the steering column.
2. Press and hold the steering column control until the steering column stops moving.
3. Press the steering column control again.

Note: The steering column may start to move again.

4. When the steering column stops, continue holding the control for a few seconds.
5. Repeat for each direction, as necessary.

HORN



Press on the center of the steering wheel near the horn icon to activate the horn.

SWITCHING THE HEATED STEERING WHEEL ON AND OFF - VEHICLES WITH: HEATED STEERING WHEEL



WARNING: Use caution when using the heated steering wheel if you are unable to feel pain to your skin because of advanced age, chronic illness, diabetes, spinal cord injury, medication, exhaustion or other physical conditions. Failure to follow this instruction could result in personal injury, especially if the heated steering wheel is used for long periods of time.



To activate the heated steering wheel, press the button on the touchscreen. An indicator illuminates when the heated steering wheel is on. To turn it off, press the heated steering wheel button again.

Note: The engine must be running to use the heated steering wheel.

Note: A sensor regulates the temperature of the steering wheel.

Note: The heated steering wheel may remain on after remote starting your vehicle, depending on the remote start settings. It may also turn on when you start your vehicle if it was on the last time the engine was switched off.

Note: In warm temperatures, the steering wheel quickly reaches its maximum temperature and the system reduces the current to the heating element. This could cause you to think that the system has stopped working but it has not. This is normal.

Adjustable Pedals

ADJUSTING THE PEDALS



WARNING: Do not use the pedal adjustment controls when the vehicle is moving. Failure to follow this instruction could result in personal injury or death.

The controls are on the right-hand side of the steering wheel. See **Using the Controls on the Steering Wheel** (page 95).

1.



Using the controls on the steering wheel, press the driver adjustment menu.

Note: *The available controls appear in the instrument cluster display.*

2.



Press the button to access the adjustable pedal option.

3.



Press the area on the steering wheel controls to move the pedals toward you as shown in the instrument cluster display.

4.



Press the area on the steering wheel controls to move the pedals away from you as shown in the instrument cluster display.



Press the button to go back to the previous menu.

Memory Foot pedals (If Equipped)

You can save and recall the pedal positions through the memory function. See **Using the Memory Function** (page 480).

Wipers and Washers

WIPERS

WIPER PRECAUTIONS

Do not operate the wipers on a dry windshield. This could scratch the glass or damage the wiper blades. Use the windshield washers before wiping a dry windshield.

Fully defrost the windshield before you switch the windshield wipers on.

Switch the windshield wipers off before entering a car wash.

SWITCHING WINDSHIELD WIPERS ON AND OFF

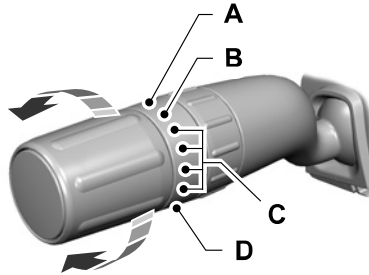

- A High-speed wipe.
- B Low-speed wipe.
- C Auto Wipe/Intermittent wipe.
- D Off.



Use the rotary control.

AUTOWIPERS (IF EQUIPPED)

WHAT ARE AUTOWIPERS

Autowipers turns on and controls the speed and frequency of the windshield wipers.

AUTOWIPERS SETTINGS

1. From the settings menu, press Vehicle.
2. Press Wipers.
3. Switch Rain sensing on or off.

Note: When you switch the feature off, the wipers do not operate based on the rain sensor. When you switch on the windshield wipers to the intermittent wipe position with the feature off, the wipers use the wipe speed set by the rotary control.

Wipers and Washers

ADJUSTING THE SENSITIVITY OF THE RAIN SENSOR

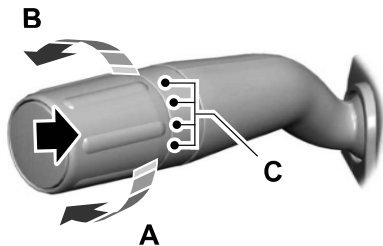

- A Low sensitivity.
- B High sensitivity.
- C Intermittent wipe/Autowipers.

Use the rotary control to set the rain sensor sensitivity.

Note: Use intermittent wipe positions to adjust the rain sensor sensitivity. See **Switching Windshield Wipers On and Off** (page 99).

When you select low sensitivity, the wipers operate when the sensor detects a large amount of water on the windshield.

When you select high sensitivity, the wipers operate when the sensor detects a small amount of water on the windshield.

SWITCHING THE REAR WINDOW WIPER ON AND OFF



Rotate the control away from you for a long wipe interval.

Rotate the control toward you for a short wipe interval.

REVERSE WIPE

WHAT IS REVERSE WIPE

Reverse wipe turns on the rear window wiper when you shift into reverse (R) and the windshield wipers are on.

REVERSE WIPE SETTINGS

1. From the settings menu, press Vehicle.
2. Press Wipers.
3. Switch Rear wiper on or off.

CHECKING THE WIPER BLADES



Run the tip of your fingers over the edge of the blade to check for roughness.

REPLACING THE FRONT WIPER BLADES

Make sure your vehicle is off before beginning this procedure.

Wipers and Washers



1. Pull the wiper blade and arm away from the glass.

Note: Do not hold the wiper blade to lift the wiper arm.

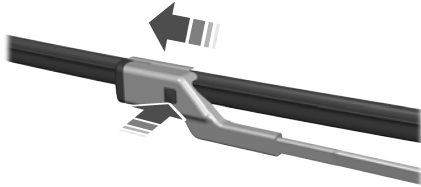

2. Press the wiper blade locking clip.
3. Remove the wiper blade.

Note: Make sure that the wiper arm does not spring back against the glass when the wiper blade is not attached.

4. To install, reverse the removal procedure.

Note: Make sure that the wiper blade locks into place.

REPLACING THE REAR WIPER BLADES

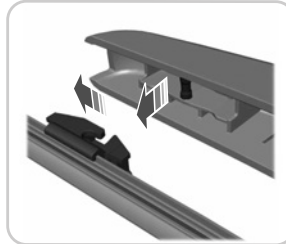
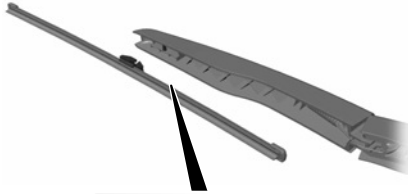

1. Lift the wiper arm.

Note: Do not hold the wiper blade to lift the wiper arm.

Note: Do not lift the wiper arm beyond the limited service-up position, as this might cause damage to the wiper arm. The limited service-up position is intended to protect the wiper arm against car washes.

2. Remove the wiper blade.

Note: Make sure that the wiper arm does not spring back against the glass when the wiper blade is not attached.

3. To install, reverse the removal procedure.

Note: Make sure that the wiper blade locks into place.

Wipers and Washers

WASHERS

WASHER PRECAUTIONS

 **WARNING:** If you operate your vehicle in temperatures below 41°F (5°C), use washer fluid with antifreeze protection. Failure to use washer fluid with antifreeze protection in cold weather could result in impaired windshield vision and increase the risk of injury or accident.

Do not operate the washers when the washer reservoir is empty. This could cause the washer pump to overheat.

Keep the outside of the windshield clean. The rain sensor is very sensitive and the wipers may operate if dirt, mist or insects hit the windshield.

USING THE WINDSHIELD WASHER

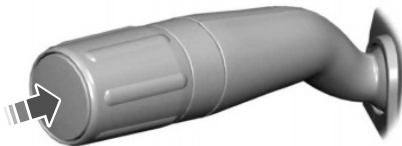

Press and hold the button at the end of the lever to operate the windshield washer.

Note: A *courtesy wipe* occurs a short time after the wipers stop to clear any remaining washer fluid when switched on. See **Switching the Courtesy Wipe On and Off** (page 102).

SWITCHING THE COURTESY WIPE ON AND OFF

1. From the settings menu, press Vehicle.
2. Press Wipers.
3. Switch Courtesy Wipe on or off.

Note: When you switch the feature on, the wipers make an additional single wipe at the end of the washer request. When you switch it off, the wipers finish the current washer request.

USING THE REAR WINDOW WASHER



Rotate the control to the top or bottom position and hold it to operate the rear window washer.

Wipers and Washers

ADDING WASHER FLUID

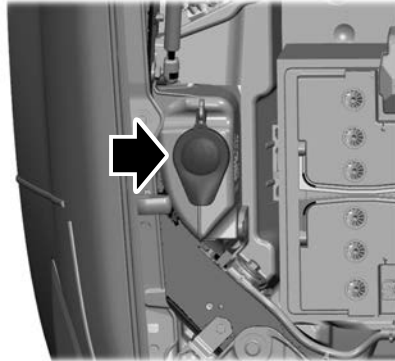

WASHER FLUID SPECIFICATION

Capacities

Variant	Quantity
All.	Fill as required.

Wipers and Washers

Materials

Name	Specification
Motorcraft® Premium Windshield Wash Concentrate with Bitterant(U.S.) Motorcraft® Premium Quality Windshield Washer Fluid -35 °C / Liquide lave-glace de haute qualité -35 °C Motorcraft®(Canada) ZC-32-B2(U.S.) CXC-37-M(Canada)	WSS-M14P19-A

WIPERS AND WASHERS – TROUBLESHOOTING

WIPERS AND WASHERS – WARNING LAMPS



Illuminates when the windshield washer fluid is low.

WIPERS AND WASHERS – FREQUENTLY ASKED QUESTIONS

Why are there streaks and smears on the windshield?

- The wiper blades could be dirty, worn or damaged. Check the wiper blades. See **Checking the Wiper Blades** (page 100). If the wiper blades are dirty, clean them with washer fluid or water applied with a soft sponge or cloth. If the wiper blades are worn or damaged, install new ones. See **Replacing the Front Wiper Blades** (page 100).

Exterior Lighting

EXTERIOR LIGHTING CONTROL



Press the button on the touchscreen to access the lighting menu.



- A Headlamps on.
- B Autolamps on.
- C Parking lamps on.
- D Lamps off.

Note: *The lighting control defaults to autolamps every time you switch your vehicle on.*

HEADLAMPS

USING THE HIGH BEAM HEADLAMPS

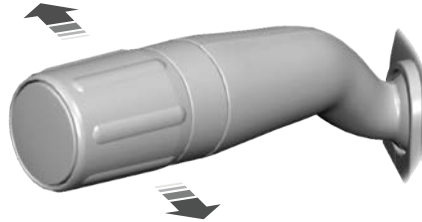

Push the lever away from you to switch the high beams on.

Push the lever forward again or pull the lever toward you to switch the high beams off.

Slightly pull the lever toward you and release it to flash the headlamps.

Note: *Continuous activation only occurs with the headlamps on.*

SWITCHING HEADLAMP EXIT DELAY ON AND OFF

To switch headlamp exit delay on, pull the turn signal lever toward you when the headlamps are off and the ignition is off. A short tone sounds when the system is on.

To switch headlamp exit delay off, pull the turn signal lever toward you again or switch your vehicle on.

Note: *The headlamps turn off after three minutes with any door open or 30 seconds after the last door closes.*

HEADLAMP INDICATORS

Lamps On



Illuminates when you switch the low beam headlamps or the parking lamps on.

Headlamp High Beam



Illuminates when you switch the high beam headlamps on.

Exterior Lighting

HEADLAMPS – TROUBLESHOOTING

HEADLAMPS – FREQUENTLY ASKED QUESTIONS

Why is there condensation in the headlamps?

- Headlamps have vents to accommodate normal changes in air pressure. Condensation can be a natural by-product of this design. When moist air enters the lamp assembly through the vents, there is a possibility that condensation can occur when the temperature is cold. When normal condensation occurs, a fine mist can form on the interior of the lens. The fine mist eventually clears and exits through the vents during normal operation.

How much condensation is acceptable?

- The presence of a fine mist, for example no streaks, drip marks or large droplets. A fine mist covers less than 50% of the lens.

How long does it take for the acceptable condensation to clear?

- Clearing time can take as long as 48 hours under dry weather conditions.

How much condensation is unacceptable?

- A water puddle inside the lamp. Streaks, drip marks or large droplets present on the interior of the lens.

What should I do if unacceptable condensation is present?

- Have your vehicle checked as soon as possible.

Why do my headlamps turn off when I have them switched on when I switch my vehicle off?

- The battery saver turns the headlamps off after a short period of time after you switch your vehicle off.

AUTOLAMPS

WHAT ARE AUTOLAMPS



WARNING: The system does not relieve you of your responsibility to drive with due care and attention. You may need to override the system if it does not turn the headlamps on in low visibility conditions, for example daytime fog.

Autolamps turn the headlamps on in low light situations or when the windshield wipers operate.

AUTOLAMP SETTINGS

Autolamp Exit Delay

You can adjust the amount of time the autolamps remain on after you switch off your vehicle. Use the touchscreen to choose a delay setting.

1. From the settings menu, press Vehicle.
2. Press Lighting.
3. Press Autolamp Delay.
4. Select a setting.

Exterior Lighting

Note: If the setting is off, the external lamps switch off immediately when you shut down your vehicle.

Note: You can pull the turn signal toward you to manually switch off the autolamp exit delay.

EXTERIOR LAMPS

USING THE TURN SIGNAL LAMPS

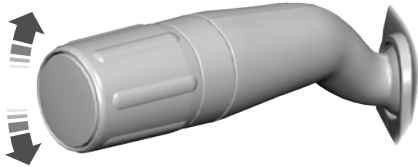

Push the lever up or down to switch the turn signal lamps on.

Set the lever to the middle position to switch the turn signal lamps off.

Note: Tap the lever up or down to make the turn signal lamps flash three times.

Turn Signal Lamp Indicator



It flashes when you switch the turn signal lamps on.

Note: An increase in the rate of flashing warns of a failed turn signal lamp.

SWITCHING THE DAYTIME RUNNING LAMPS ON AND OFF - VEHICLES WITH: CONFIGURABLE DAYTIME RUNNING LAMPS



WARNING: The daytime running lamps system does not activate the rear lamps and may not provide adequate lighting during low visibility driving conditions. Make sure you switch the headlamps on, as appropriate, during all low visibility conditions. Failure to do so may result in a crash.

1. From the settings menu, press Vehicle.
2. Press Lighting.
3. Switch Daytime Running Lights on or off.

The daytime running lamps turn on when all of the following occur:

- You switch the system on.
- You switch your vehicle on.
- The transmission is not in park (P) for vehicles with automatic transmissions or you release the parking brake for vehicles with manual transmissions.
- The lighting control is in the autolamps position.
- The headlamps are off.

Note: Other lighting control positions do not turn on the daytime running lamps.

SWITCHING THE DAYTIME RUNNING LAMPS ON AND OFF - VEHICLES WITH: DAYTIME RUNNING LAMPS (DRL)



WARNING: The daytime running lamps system may not activate the rear lamps and may not provide adequate lighting during low visibility driving conditions. Make sure you switch the headlamps on, as appropriate, during all low visibility conditions. Failure to do so may result in a crash.

Exterior Lighting

Daytime running lamps are always on unless you switch on the headlamps or your vehicle is in park (P).

USING THE FRONT FOG LAMPS (if Equipped)

To switch the lamps on or off:

1. Set the lighting control to parking lamps, headlamps or autolamps on the touchscreen.

Note: When the lighting control is set to autolamps, during the day you can switch on the front fog lamps; the system will then turn on the low beam lamps.

2.  Press the button on the lighting menu to switch the front fog lamps on or off.

Note: Only switch the front fog lamps on during reduced visibility.

Note: The brightness of the daytime running lamps may decrease when you switch the front fog lamps on.

Note: The front fog lamps automatically switch off when you or the system activate the high beams.

Front Fog Lamps Indicator



It illuminates when you switch the front fog lamps on.

SWITCHING THE REAR FLOODLAMPS ON AND OFF

The rear floodlamps automatically turn on when you open the liftgate.

Note: The rear floodlamps turn off approximately 10 minutes after the liftgate is opened.



You can also press the button in the cargo area to switch the rear floodlamps on and off.



Note: The rear floodlamps turn off approximately 30 minutes after you switch them on manually.

Note: The rear floodlamps automatically turn off when the liftgate is closed.

USING THE OFF-ROAD DRIVING LAMPS

The grille-mounted lamps provide supplementary lighting for off-road driving. It is your responsibility to use these lamps only when your vehicle is off-road.

To activate the lamps, follow steps 1-5. If the lamps are already active, skip to step 6.

1.  Press the button on the touchscreen.
2. Press Lighting.
3. Make sure the exterior lighting control is set to headlamps or autolamps.
4. Press Off-Road.
5.  Press the off-road lamps button on the touchscreen. A message may appear on the screen.

Note: If the high beams are already on, then the off-road lamps will switch on.

Note: The off-road lamps do not function with auto high beams.

6. Switch the high beams on. See **Using the High Beam Headlamps** (page 105).

Exterior Lighting

To switch the lamps off, perform any one of the following:

- Switch the high beams off. See **Using the High Beam Headlamps** (page 105).
- Press the off-road lamps button on the touchscreen.
- Switch the exterior lighting control to the off position.
- Switch your vehicle off.

Note: Switching your vehicle off disables the off-road lamps. You will need to enable them in the touchscreen again when you switch on your vehicle.

Off-Road Driving Lamps Indicator



Illuminates when you switch the off-road lamps on.

EXTERIOR LAMPS ON AUDIBLE WARNING

Sounds when you open the driver door and the exterior lamps are on.

EXTERIOR ZONE LIGHTING (IF EQUIPPED)

WHAT IS EXTERIOR ZONE LIGHTING

Exterior zone lighting divides the exterior lighting into zones and allows you to switch them on and off to provide lighting around the perimeter of your vehicle.

USING THE EXTERIOR ZONE LIGHTING

From the lighting control menu, press Zone.

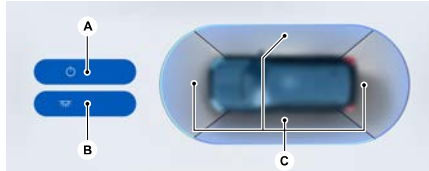

- A On and off button.
- B All zones on and off.
- C Individual zones on and off.

You can use zone lighting when your vehicle is on or off. When it is off, the lighting turns off after a certain period of time.

You can also use individual zone controls to switch on each zone.

Note: Make sure to remove exterior lighting covers when using zone lighting.

Note: When your vehicle is off and the timer has one minute remaining, the turn signals flash six times.

Note: Indicators on the touchscreen illuminate when the lights outside of the zone lighting control are on.

Note: You can remotely control the zone lighting using the FordPass app.

Zone Lighting Settings

From the Zone menu, touch the Settings button to access zone lighting settings.

Enable Autolamp Override

This setting allows the vehicle to override the autolamps when zone lighting is on.

When you access zone lighting for the first time, you can choose this setting. You can change this setting at any time.

Exterior Lighting

Enable Reversing Lamps

This setting allows the feature to turn on reversing lamps when you activate the rear zone.

AUTOMATIC HIGH BEAM CONTROL

HOW DOES AUTOMATIC HIGH BEAM CONTROL WORK

Automatic high beam control turns the high beams on if it is dark enough and no other traffic is present. If it detects an approaching vehicle's headlamps or tail lamps, or street lighting ahead, the system turns the high beams off.

A camera sensor, centrally mounted behind the windshield of your vehicle, continuously monitors conditions to turn the high beams on and off.

Exterior Lighting

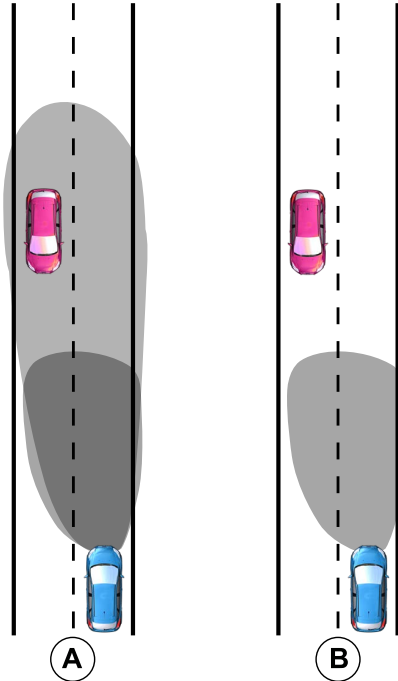



- A Without automatic high beam control.
- B With automatic high beam control.

AUTOMATIC HIGH BEAM CONTROL PRECAUTIONS

 **WARNING:** The system does not relieve you of your responsibility to drive with due care and attention. You may need to override the system if it does not turn the high beams on or off.

 **WARNING:** The system may not switch the high beams off if the lights of oncoming vehicles are hidden by obstacles, for example guard rails.

 **WARNING:** You may need to override the system when approaching other road users.

 **WARNING:** In situations with poor visibility, such as fog, heavy rain or other inclement weather, you may need to override or completely switch off the system.

AUTOMATIC HIGH BEAM CONTROL REQUIREMENTS

The system turns the high beams on if all of the following occur:

- You switch the system on.
- You set the lighting control to the autolamps position.
- The ambient light level is low enough that you require high beams.
- There is no traffic in front of your vehicle.
- The vehicle speed is greater than approximately 25 mph (40 km/h).

AUTOMATIC HIGH BEAM CONTROL LIMITATIONS

The system turns the high beams off if any of the following occur:

- You switch the system off.
- You set the lighting control to any position except autolamps.
- The ambient light level is high enough that you do not require high beams.
- The system detects an approaching vehicle's headlights or a leading vehicle's tail lamps.

Exterior Lighting

- The system detects severe rain, snow or fog.
- The system detects street lighting.
- The camera has reduced visibility.
- The vehicle speed falls below approximately 19 mph (30 km/h).

Note: *The deactivation speed may be lower on curves.*

SWITCHING AUTOMATIC HIGH BEAM CONTROL ON AND OFF

You can switch the feature on and off using the touchscreen.

AUTOMATIC HIGH BEAM CONTROL INDICATORS



Illuminates to confirm when the system is ready to assist.

OVERRIDING AUTOMATIC HIGH BEAM CONTROL

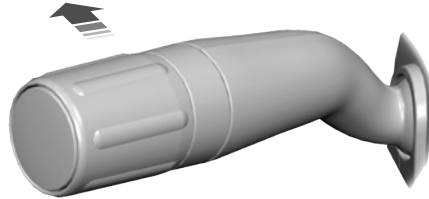

Push the lever away from you to switch the high beams on.

Push the lever away from you again to switch the high beams off.

Push the lever away from you for a third time to switch automatic high beam control back on.

Exterior Lighting

AUTOMATIC HIGH BEAM CONTROL – TROUBLESHOOTING

AUTOMATIC HIGH BEAM CONTROL – INFORMATION MESSAGES

Message	Details
Front Camera Low Visibility Clean Screen	The camera has reduced visibility. Clean the windshield. If the message continues to appear, have your vehicle checked as soon as possible.
Front Camera Temporarily Not Available	The camera has malfunctioned. Wait a short period of time for the camera to cool down. If the message continues to appear, have your vehicle checked as soon as possible.
Front Camera Malfunction Service Required	The camera has malfunctioned. Have your vehicle checked as soon as possible.

Interior Lighting

SWITCHING ALL OF THE INTERIOR LAMPS ON AND OFF

The lamps turn on under the following conditions:

- You open any door.
- You press a button on the remote control.
- You press the all lamps on button on the overhead console.



Press to switch all interior lamps on or off.

SWITCHING THE FRONT INTERIOR LAMPS ON AND OFF

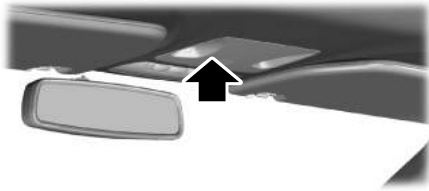

The front interior lamp switches are on the overhead console.

Note: *The position of each button on the overhead console depends on your vehicle.*

Individual Map Lamps



Press to switch the left-hand individual dome lamp on and off.



Press to switch the right-hand individual dome lamp on and off.

SWITCHING THE REAR INTERIOR LAMPS ON AND OFF



The rear interior lamps may be above the rear seat or above the rear windows.



Press to switch the lamps on or off.

Note: *If you switch the rear lamps on through the overhead console, you cannot switch them off with the rear lamp switch.*

INTERIOR LAMP FUNCTION

WHAT IS THE INTERIOR LAMP FUNCTION

The interior lamp function switches the courtesy and door lamps on or off.

SWITCHING THE INTERIOR LAMP FUNCTION ON AND OFF



Press to switch the interior lamp function on and off.

Note: *The indicator lamp illuminates amber when the door function is off.*

Interior Lighting

ADJUSTING THE INSTRUMENT PANEL LIGHTING BRIGHTNESS

1. From the controls menu, press Lighting.
2. Press Interior.
3. Drag the slider to adjust the brightness of the instrument panel lighting.

Note: *There are six stages of brightness adjustments available during the day and twelve stages of brightness adjustments are available at night.*

AMBIENT LIGHTING (IF EQUIPPED)

SWITCHING AMBIENT LIGHTING ON AND OFF

1. From the controls menu, press Ambient Lighting.
2. Press a color to switch ambient lighting on.

3.  Press the power button to switch ambient lighting off.

Note: *The power button icon appears in whichever ambient lighting color you select.*

ADJUSTING AMBIENT LIGHTING

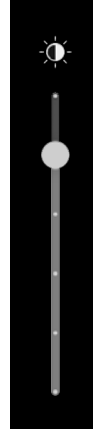

Drag the slider up or down to adjust the ambient lighting intensity.

INTERIOR LIGHTING – TROUBLESHOOTING

INTERIOR LIGHTING – FREQUENTLY ASKED QUESTIONS

Why do my courtesy lamps or interior lamps turn off when I have them switched on when I switch my vehicle off?

- The battery saver turns the courtesy lamps and interior lamps off after a short period of time after you switch your vehicle off.

Windows

OPENING AND CLOSING THE WINDOWS



WARNING: Do not leave children or pets unattended in your vehicle and do not let children play with the power windows. Failure to follow this instruction could result in personal injury or death.



WARNING: When closing the power windows, verify that they are free of obstructions and make sure children and pets are not in the proximity of the window openings. Failure to follow this instruction could result in personal injury or death.



WARNING: If an obstruction is detected, release the switch and reverse the window immediately. Failure to follow this instruction could result in personal injury or death.



WARNING: Do not leave a key or remote control unattended in the vehicle. Children or pets could operate the power windows and could become trapped in a closing window. Failure to follow this instruction could result in personal injury or death.



Press the window control switch to open the window. Lift the window control switch to close the window.

Note: *The power windows operate with the ignition on, and for several minutes after you switch the ignition off or until you open a front door.*

To reduce wind noise or pulsing noise when one window is open, slightly open the opposite window.

One-Touch Open

Fully press the window control switch and release it. Press again or lift it to stop the window.

One-Touch Close

Fully lift the window control switch and release it. Press again or lift it to stop the window.

Resetting One-Touch Open and Close

If the one-touch open and close feature fails, please reset it according to the following steps:

Carry out all steps within 30 seconds of starting the sequence.

1. Close the window.
2. Press and hold the window control switch until the window is fully open. Keep the window control switch pressed for a few seconds.
3. Lift and hold the window control switch until the window is fully closed. Keep the window control switch held for a few seconds.
4. Press and hold the window control switch until the window is fully open. Keep the window control switch pressed for a few seconds.
5. Lift and hold the window control switch until the window is fully closed. Keep the window control switch held for a few seconds.

Note: *Repeat the procedure if the window does not close when you use one-touch.*

GLOBAL OPENING AND CLOSING

WHAT IS GLOBAL OPENING AND CLOSING

You can use the remote control to operate the windows with the ignition off.

Windows

USING GLOBAL OPENING

1. Press and release the unlock button on the remote control.
2. Within one second, press and hold the unlock button on the remote control.
3. Release the button when the windows start to open.

Press the lock or the unlock button on the remote control to stop global opening.

Note: *Global opening will only respond to a press and hold of the unlock button for a short period of time after the unlock button is pressed on the remote control.*

SWITCHING GLOBAL OPENING ON AND OFF

1. From the settings menu, press Vehicle.
2. Press Windows.
3. Switch Remote open on or off.

USING GLOBAL CLOSING



WARNING: When closing the power windows, verify that they are free of obstructions and make sure children and pets are not in the proximity of the window openings. Failure to follow this instruction could result in personal injury or death.

1. Press and hold the lock button on the remote control.
2. Release the button when the windows start to close.

Press the lock or the unlock button on the remote control to stop global closing.

Note: *Bounce-back is on during global closing. See **What Is Window Bounce-Back** (page 117).*

SWITCHING GLOBAL CLOSING ON AND OFF

1. From the settings menu, press Vehicle.
2. Press Windows.
3. Switch Remote close on or off.

WINDOW BOUNCE-BACK

WHAT IS WINDOW BOUNCE-BACK

The window stops and reverses if it detects an obstruction when closing.

OVERRIDING WINDOW BOUNCE-BACK



WARNING: If you override bounce-back, the window does not reverse if it detects an obstacle. Take care when closing the windows to avoid personal injury or damage to your vehicle.

1. Close the window until it reaches the point of resistance and let it reverse.
2. Lift and hold the window control switch within two seconds to override bounce-back and close the window. Bounce-back is now disabled and you can close the window manually.

Note: *The window goes past the point of resistance and you can fully close it.*

Note: *If the window does not close, have your vehicle checked as soon as possible.*

Windows

LOCKING THE REAR WINDOW CONTROLS



WARNING: When children and pets are in the rear seat, use the power window lockout button to prevent accidental operation of the power windows.



Press the window control switch to lock or unlock the rear window controls. It illuminates when you lock the rear window controls.

Interior Mirror

INTERIOR MIRROR PRECAUTIONS



WARNING: Do not adjust the mirrors when your vehicle is moving. This could result in the loss of control of your vehicle, serious personal injury or death.

Note: Do not clean the mirror housing or glass with harsh abrasives, fuel or other petroleum-based cleaning products.

MANUALLY DIMMING THE INTERIOR MIRROR

Pull the tab below the mirror toward you to reduce glare at night.

AUTO-DIMMING INTERIOR MIRROR (IF EQUIPPED)

WHAT IS THE AUTO-DIMMING INTERIOR MIRROR

The mirror dims to reduce the effect of bright light from behind. It returns to normal when the bright light from behind is no longer present or if you shift into reverse (R).

AUTO-DIMMING INTERIOR MIRROR LIMITATIONS

Do not block the sensors on the front and back of the mirror.

Note: A rear center passenger or raised rear center head restraint could prevent light from reaching the sensor.

Exterior Mirrors

ADJUSTING THE EXTERIOR MIRRORS

WARNING: Do not adjust the mirrors when your vehicle is moving. This could result in the loss of control of your vehicle, serious personal injury or death.

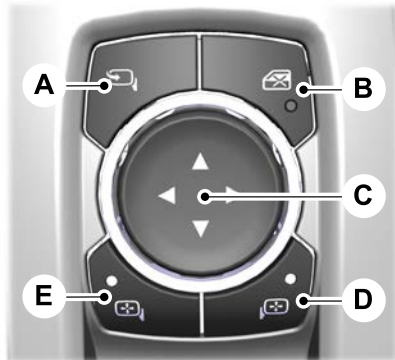

- A Power fold.
- B Window lock.
- C Adjustment control.

- D Right-hand mirror.
- E Left-hand mirror.

To adjust the mirrors, switch your vehicle on and place the ignition in accessory or start.

1. Select the mirror you want to adjust. The control light turns on.
2. Use the adjustment control to adjust the position of the mirror.
3. Press the mirror control again. The control light turns off.

FOLDING THE EXTERIOR MIRRORS - VEHICLES WITH: MANUAL FOLDING MIRRORS

Push the mirror toward the door window glass. Make sure that you fully engage the mirror in its support when returning it to its original position.

Heated Exterior Mirrors

See **Switching the Heated Mirrors On and Off** (page 130).

Memory Mirrors

You can save and recall the mirror positions through the memory function. See **Using the Memory Function** (page 480).

Directional Indicator Mirrors (If Equipped)

When your vehicle is running, the forward-facing portion of the appropriate mirror housing blinks when you switch on the turn signal.

Puddle Lamps

The puddle lamps turn on when you approach your vehicle with a remote control or phone. If your vehicle has auto-folding mirrors, the puddle lamps are only on if the mirrors are unfolded and turn off when the mirrors fold.

360 Degree Camera

See **Locating the 360 Degree Cameras** (page 251).

Blind Spot Information System

See **What Is Blind Spot Information System** (page 296).

Exterior Mirrors

FOLDING THE EXTERIOR MIRRORS - VEHICLES WITH: POWER FOLDING MIRRORS

With the auto-fold feature enabled, the exterior mirrors fold in toward the glass after you place the transmission into park (P), turn off the vehicle, open and close the driver side door and lock the vehicle. The exterior mirrors unfold and return to their driving position after you unlock the vehicle.



For tight parking conditions, press the control to fold the mirrors.

Press the control again to unfold the mirrors.

If you press the control to fold in the mirrors with auto-fold on, the mirrors do not unfold when you unlock your vehicle.

Note: *The power folding mirrors operate with the ignition on, and for several minutes after you switch the ignition off.*

Note: *If you fold and unfold the mirrors several times within one minute, the power fold function may turn off to protect the motors from overheating.*

Switching Auto-fold On and Off

1. From the settings menu, press Vehicle.
2. Press Mirrors.
3. Switch Autofold on or off.

Loose, Noisy or Intermittently Working Mirrors

If you manually fold the power folding mirrors, they may not work properly even after you reposition them. Reset the mirrors if:

- They vibrate when you drive.
- They feel loose.
- They do not stay in the folded or unfolded position.
- One of the mirrors is not in its normal driving position.
- The mirrors are intermittently working.

To reset the power fold feature, use the power folding mirror control to fold and unfold the mirrors. You may hear a loud noise as you reset the power folding mirrors. This sound is normal. Operate the power folding mirrors an additional 3 to 4 times to synchronize the mirrors.

If the above process does not help you to fix the mirror, perform the following steps.

1. Fold or retract both mirrors manually.
2. Using the power folding control switch, operate the mirrors until you hear an audible click.
3. Operate the power folding an additional 3 to 4 times to synchronize the mirrors.

Repeat this process as needed each time you manually fold the mirrors.

AUTO-DIMMING EXTERIOR MIRROR (IF EQUIPPED)

WHAT IS THE AUTO-DIMMING EXTERIOR MIRROR

The driver exterior mirror dims when the interior auto-dimming mirror turns on.

Glass Roof

OPENING AND CLOSING THE SUNSHADE

 **WARNING:** Do not leave a key or remote control unattended in the vehicle. Children or pets could operate the sunshade and get caught in a closing sunshade. Failure to follow this instruction could result in personal injury.

 **WARNING:** Do not leave children or pets unattended in your vehicle and do not let children play with the sunshade. Failure to follow this instruction could result in personal injury.

The controls are on the overhead console.

Opening the Sunshade



Press and release the switch to activate the one-touch open feature. To stop movement, press the switch a second time. The sunshade also opens when you open the glass roof.

Note: *The sunshade stops short of its fully opened position for the comfort of rear passengers. To fully open the sunshade, press the switch again.*

Closing the Sunshade

 **WARNING:** When closing the sunshade, verify that it is free of obstructions and make sure children and pets are not in the proximity of the sunshade. Failure to follow this instruction could result in personal injury.

 **WARNING:** If an obstruction is detected, press the switch a second time and reverse the sunshade immediately. Failure to follow this instruction could result in personal injury.





Press and release the switch to activate the one-touch close feature. To stop movement, press the switch a second time.

Note: *If fully open, the sunshade stops after covering the rear glass panel. Press and release again to fully close the sunshade.*

Note: *If the glass roof is either in the open or vent position and the sunshade is in the mid-open position, press and release the switch to close the glass roof first and then the sunshade.*

OPENING AND CLOSING THE GLASS ROOF

 **WARNING:** Do not allow anyone to stand or place any portion of their body through the open glass roof while the vehicle is in motion. Make sure everyone in your vehicle is in a seat and properly using a seatbelt. Failure to follow this warning could result in serious injury or death in the event of a sudden stop or crash.

 **WARNING:** Do not leave children or pets unattended in your vehicle and do not let children play with the glass roof. Failure to follow this instruction could result in personal injury.

 **WARNING:** Do not leave a key or remote control unattended in the vehicle. Children or pets could operate the glass roof and could become trapped in a closing glass roof. Failure to follow this instruction could result in personal injury or death.

The controls are on the overhead console.

Glass Roof

Opening the Glass Roof



Press and release the switch to activate the one-touch open feature. To stop movement, press the switch a second time.

Note: *The glass roof stops short of the fully opened position to reduce wind noise or rumbling that may happen with the glass roof fully open.*

Press and release the switch again to fully open the glass roof.

Closing the Glass Roof



WARNING: When closing the glass roof, verify that it is free of obstructions and make sure children and pets are not in the proximity of the glass roof. Failure to follow this instruction could result in personal injury or death.



WARNING: If an obstruction is detected, release the switch and reverse the glass roof immediately. Failure to follow this instruction could result in personal injury or death.



Press and release the switch to activate the one-touch close feature, from either the open or vent positions. To stop movement, press the switch a second time.

VENTING THE GLASS ROOF



WARNING: Do not leave children or pets unattended in your vehicle and do not let children play with the glass roof. Failure to follow this instruction could result in personal injury.

The glass roof controls are on the overhead console.



With the glass roof in the closed position, press and release the switch to vent the glass roof. To close the glass roof from the vent position, press and release the switch again.

GLASS ROOF BOUNCE-BACK

WHAT IS GLASS ROOF BOUNCE-BACK

The glass roof stops and reverses some distance if it detects an obstacle when closing.

OVERRIDING GLASS ROOF BOUNCE-BACK

Press and hold the close switch within two seconds after the glass roof comes to a stop.

Instrument Cluster

INSTRUMENT CLUSTER OVERVIEW



- A Fuel gauge.
- B Speedometer.
- C Information on demand areas.
- D Engine coolant temperature gauge.
- E Transmission position indicator.
- F Compass.
- G Outside air temperature.
- H Odometer.
- I Distance to empty.

Instrument Cluster

TACHOMETER

Indicates the engine speed.

SPEEDOMETER

Indicates the vehicle speed.

FUEL GAUGE

WHAT IS THE FUEL GAUGE

Indicates approximately how much fuel is in the fuel tank.

FUEL GAUGE LIMITATIONS

The fuel gauge may not provide an accurate reading when your vehicle is on an incline.

LOCATING THE FUEL FILLER DOOR

The arrow adjacent to the fuel pump symbol indicates on which side of your vehicle the fuel filler door is located.

WHAT IS THE LOW FUEL REMINDER

A low fuel level reminder displays and sounds when the distance to empty reaches 50 mi (80 km), 25 mi (40 km), 10 mi (20 km) and 0 mi (0 km).

Note: *The low fuel reminder can appear at different fuel gauge positions depending on fuel economy conditions. This variation is normal.*

WHAT IS DISTANCE TO EMPTY

Indicates the approximate distance your vehicle can travel on the fuel remaining in the tank. Changes in driving pattern can cause the value to not only decrease but also increase or stay constant for periods of time.

ENGINE COOLANT TEMPERATURE GAUGE

Indicates the engine coolant temperature.

Trip Computer

ACCESSING THE TRIP COMPUTER

1. Access the instrument panel display screen. See **Customizing the Instrument Panel Display** (page 470).
2. Press a trip tile.

Note: *The active trip tile displays in the active tile area.*

RESETTING THE TRIP COMPUTER

The trip tile must be in the active tile area to reset it.

1. Access the instrument panel display screen. See **Customizing the Instrument Panel Display** (page 470).
2. Press the trip tile in the active tile area.
3. Press reset.

Remote Start

USING REMOTE START - VEHICLES WITH: FORD MOBILE APP/PHONE AS A KEY



WARNING: Do not start the engine in a closed garage or in other enclosed areas. Exhaust fumes are toxic. Always open the garage door before you start the engine. Failure to follow this instruction could result in personal injury or death.



WARNING: Do not keep electrical devices plugged in the power outlet whenever the device is not in use. Power outlets power up during remote start.

The system allows you to remotely start your vehicle to heat or cool the interior to a preset temperature.

Follow the instructions in the vehicle app to start and stop your vehicle.

Note: *The vehicle app must be paired with your vehicle to remotely start using the app.*

Note: *Depending on your vehicle app, you may need to be within a certain range for the vehicle to successfully remote start.*

When you successfully remote start your vehicle:

- The vehicle doors lock.
- The turn signal lamps flash twice.
- The parking lamps turn on when the vehicle is running.
- The vehicle remains secured when you have remotely started the vehicle. A valid key must be inside your vehicle to switch your vehicle on and drive your vehicle.
- All other vehicle systems remain off when you have remotely started the vehicle.

The horn sounds if the system fails to start.

Note: *You cannot adjust any comfort settings until you switch your vehicle on from inside your vehicle.*

Remote start does not work under the following conditions:

- Remote start is not enabled.
- The alarm horn is sounding.
- The hood is open.
- The transmission is not in park (P).
- Your vehicle is already on.

Note: *Do not use remote start if your fuel level is low.*

Note: *A maximum of two remote starts are allowed. After that you have to switch your vehicle on and off before you can use remote start again.*

USING REMOTE START - VEHICLES WITH: REMOTE CONTROL



WARNING: Do not start the engine in a closed garage or in other enclosed areas. Exhaust fumes are toxic. Always open the garage door before you start the engine. Failure to follow this instruction could result in personal injury or death.



WARNING: Do not keep electrical devices plugged in the power outlet whenever the device is not in use. Power outlets power up during remote start.

The system allows you to remotely start your vehicle to heat or cool the interior to a preset temperature.

1.



Press the button on the remote control.

Remote Start

2.  Press the button twice within a few seconds.

When you successfully remote start your vehicle:

- The vehicle doors lock.
- The turn signal lamps flash twice.
- The parking lamps turn on when the vehicle is running.
- The vehicle remains secured when you have remotely started the vehicle. A valid key must be inside your vehicle to switch your vehicle on and drive your vehicle.
- All other vehicle systems remain off when you have remotely started the vehicle.

The horn sounds if the system fails to start.

Note: *You cannot adjust any comfort settings until you switch your vehicle on from inside your vehicle.*

Remote start does not work under the following conditions:

- Remote start is not enabled.
- The alarm horn is sounding.
- The hood is open.
- The transmission is not in park (P).
- Your vehicle is already on.

Note: *Do not use remote start if your fuel level is low.*

Note: *A maximum of two remote starts are allowed. After that you have to switch your vehicle on and off before you can use remote start again.*



To remotely stop your vehicle, press the button.

REMOTE START SETTINGS

1. From the settings menu, press Vehicle.
2. Press Remote Start Setup.

You can adjust the following in the remote start settings menu:

- Enable or disable remote start.
- Climate control settings.
- Heated seat settings.
- Heated steering wheel settings.
- Remote start duration.

Climate Control

IDENTIFYING THE CLIMATE CONTROL UNIT



Depending on your vehicle options, the controls could look different than what you see here.

SWITCHING CLIMATE CONTROL ON AND OFF



Press the button to access the climate controls.



Press the button.

SWITCHING RECIRCULATED AIR ON AND OFF



Press the button to access the climate controls.



Press the button to recirculate air currently in the passenger compartment.

Note: *Recirculated air may turn off automatically, or prevent you from switching on in all air flow modes except MAX A/C to reduce the risk of fogging. Recirculation may also turn on and off automatically in various air distribution control combinations to improve heating or cooling efficiency.*

SWITCHING AIR CONDITIONING ON AND OFF



Press the button.

Note: *Under certain conditions, the air conditioning compressor could continue to operate after you switch air conditioning off.*

Note: *To keep the system and its components fully functional, switch air conditioning on and let your vehicle idle at least once per month for a minimum of two minutes.*

SWITCHING DEFROST ON AND OFF



Press the button to access the climate controls.



Press the button.

SWITCHING MAXIMUM DEFROST ON AND OFF



Press the button.

Air flows through the windshield air vents, the temperature is set to the highest setting, and the blower motor adjusts to the highest speed.

You can also use this setting to defog and clear the windshield of a thin covering of ice.

Climate Control

Note: To prevent window fogging, you cannot select recirculated air when maximum defrost is on.

Note: The heated rear window and heated mirrors also turn on when you select maximum defrost.

Note: When maximum defrost is on, the air conditioning compressor may continue to operate even though you switch off the A/C.

SWITCHING MAXIMUM COOLING ON AND OFF



Press the button.

Note: When you switch maximum cooling off, air conditioning remains on.

SWITCHING THE HEATED REAR WINDOW ON AND OFF



Press the button to clear the rear window of thin ice and fog. The heated rear window turns off after a short period of time.

Note: Do not use harsh chemicals, razor blades or other sharp objects to clean or remove decals from the inside of the heated rear window as this could cause damage to the heated rear window grid lines not covered by the vehicle Warranty.

SETTING THE BLOWER MOTOR SPEED



Press the button to switch the blower motor on.



Slide the control to set the blower motor speed.

SWITCHING THE HEATED MIRRORS ON AND OFF

When you switch the heated rear window on, the heated exterior mirrors turn on. See **Switching the Heated Rear Window On and Off** (page 130).

Note: Do not remove ice from the mirrors with a scraper or adjust the mirror glass when it is frozen in place.

Note: Do not clean the mirror housing or glass with harsh abrasives, fuel or other petroleum-based cleaning products. The vehicle warranty may not cover damage caused to the mirror housing or glass.

Note: The engine must be running or your vehicle must be ready to drive to switch the system on.

SETTING THE TEMPERATURE



Adjusting the arrows on either side of the climate control sets the temperature for the respective sides.

< Press the arrow to decrease the temperature.

> Press the arrow to increase the temperature.

Note: The blue arrow decreases and the red arrow increases the temperature. Pressing the temperature value allows you to control it using the slider.



Press the button to switch dual mode on.

Climate Control

DIRECTING THE FLOW OF AIR

Directing Air to the Windshield Air Vents



Press the button on the touchscreen to access the climate controls.



Press the button.

Directing Air to the Instrument Panel Air Vents



Press the button on the touchscreen to access the climate controls.



Press the button.

Directing Air to the Footwell Air Vents



Press the button on the touchscreen to access the climate controls.



Press the button.

LOCKING THE REAR PASSENGER CLIMATE CONTROLS

To access the rear climate lockout menu:

1. From the controls menu, press Parental Controls.

2.



Press rear climate to lock and unlock the controls.

AUTO MODE

SWITCHING AUTO MODE ON AND OFF



Press the button to switch auto mode on. Repeatedly press the button to adjust auto mode.

Note: When you switch auto mode on, lights on the blower motor control do not illuminate to indicate the blower motor speed.

Adjust the blower motor control or air distribution control to switch auto mode off.

AUTO MODE INDICATORS

The indicators are on the Auto Mode button.

Climate Control

Auto Mode Indicator Status	Description
One indicator illuminated.	The blower motor speed is reduced. Use this setting to minimize the amount of noise from the blower motor. This setting increases the time taken to cool the interior.
Two indicators illuminated.	The blower motor speed is moderate.
Three indicators illuminated.	The blower motor speed is increased. Use this setting to reduce the time taken to cool the interior. This setting increases the amount of noise from the blower motor.

Climate Control

SWITCHING DUAL MODE ON AND OFF



Press the button.

CLIMATE CONTROL HINTS

General Hints

- Prolonged use of recirculated air may cause the windows to fog up.
- You may feel a small amount of air from the footwell air vents regardless of the air distribution setting.
- To reduce humidity build-up inside your vehicle, do not drive with the system switched off or with recirculated air always switched on.
- Do not place objects under the front seats as this may interfere with the airflow to the rear seats.
- Remove any snow, ice or leaves from the air intake area at the base of the windshield.
- To improve the time to reach a comfortable temperature in hot weather, drive with the windows open until you feel cold air through the air vents.

Automatic Climate Control

- Adjusting the settings when your vehicle interior is extremely hot or cold is not necessary. Automatic mode is best recommended to maintain set temperature.
- The system adjusts to heat or cool the interior to the temperature you select as quickly as possible.
- For the system to function efficiently, the instrument panel and side air vents should be fully open.
- If you press **AUTO** during cold outside temperatures, the system directs air flow to the windshield and side window air vents. In addition, the blower motor may run at a slower speed until the engine warms up.
- If you press **AUTO** during hot temperatures and the inside of the vehicle is hot, the system uses recirculated air to maximize interior cooling. Blower motor speed may also reduce until the air cools.

Quickly Heating the Interior

1. Press **AUTO**.
2. Adjust the temperature function to the setting you prefer.

Recommended Settings for Heating

1. Press **AUTO**.
2. Adjust the temperature function to the setting you prefer. Use 72°F (22°C) as a starting point, then adjust the setting as necessary.

Quickly Cooling the Interior

1. Press **MAX A/C**.
2. Drive with the windows open for a short period of time.

Recommended Settings for Cooling

1. Press **AUTO**.
2. Adjust the temperature function to the setting you prefer. Use 72°F (22°C) as a starting point, then adjust the setting as necessary.

Defogging the Side Windows in Cold Weather

1. Press and release defrost or maximum defrost.
2. Adjust the temperature control to the setting you prefer. Use 72°F (22°C) as a starting point, then adjust the setting as necessary.

Climate Control

AIR CONDITIONING SYSTEM REFRIGERANT



WARNING: The air conditioning refrigerant system contains refrigerant under high pressure. Only qualified personnel should service the air conditioning refrigerant system. Opening the air conditioning refrigerant system can cause personal injury.

Your vehicle has an under hood label that identifies the refrigerant used by the air conditioning system.

Note: Only allow a trained and certified technician service the refrigerant system to ensure proper and safe operation, per the society of automotive engineers J2845.

Note: Never repair or replace the air conditioning evaporator with one from a salvage vehicle. Only replace it with a new evaporator to ensure proper and safe operation.

The meaning of each symbol on the under hood label are as follows:



Caution



Air conditioning system.



System lubricant type.



See vehicle service manual for service information.



Requires registered technician to service.



Flammable refrigerant.



Replace safety system components. Do not repair, reuse or try to salvage.

Rear Passenger Climate Control

IDENTIFYING THE REAR PASSENGER CLIMATE CONTROL UNIT



Note: Depending on your vehicle option package, the controls could look different from what you see here.

SWITCHING THE REAR PASSENGER CLIMATE CONTROLS ON AND OFF



Press and release the button to switch the rear climate control on or off.

Note: If the system is on and Max Defrost is switched on through the front climate controls, the system turns off. It turns back on when Max Defrost is switched off.

Note: If Max Defrost is switched on, the system can be turned on at the same time.

SETTING THE BLOWER MOTOR SPEED

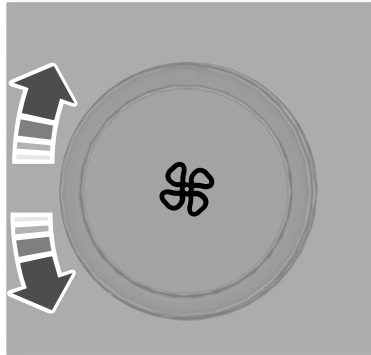

Turn the control to adjust the volume of air circulated in the rear passenger compartment.

SETTING THE TEMPERATURE

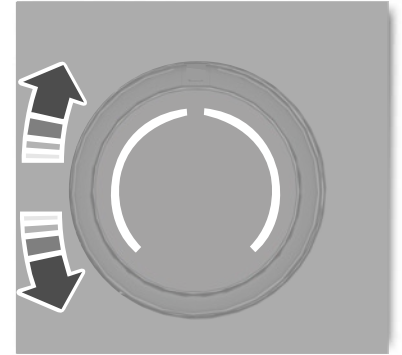

Turn the control to set the temperature in the rear passenger compartment.

DIRECTING THE FLOW OF AIR

Directing Air to the Overhead Air Vents



Press and release the button to direct airflow to the overhead air vents.

Rear Passenger Climate Control

Directing Air to the Rear Footwell Air Vents



Press and release the button to direct airflow to rear footwell air vents.

REAR AUTO MODE

SWITCHING REAR AUTO MODE ON AND OFF



Press and release the button to switch on rear automatic operation, then set the temperature.

REAR PASSENGER CLIMATE CONTROL INDICATORS



When illuminated, you can only operate the rear passenger settings through the front controls.

Interior Air Quality

WHAT IS THE CABIN AIR FILTER

The cabin air filter improves the quality of air in your vehicle by trapping dust, pollen and other particles.

REPLACING THE CABIN AIR FILTER

Replace the filter at regular intervals. See **Scheduled Maintenance** (page 490).

The cabin air filter is behind the glove compartment.

To remove the lower glove compartment and access the filter:

1. Open the glove compartment.

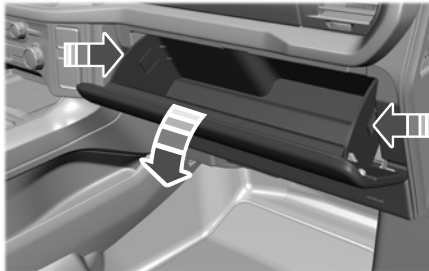

2. Press the tab on each side.
3. Fully lower the glove compartment.
4. Pull the glove compartment toward you.
5. Unclip both sides of the filter door and swing the door down to access the filter.

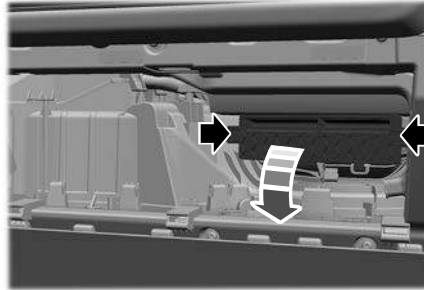

6. Remove the old filter and replace with a new filter.

Front Seats

FRONT SEAT PRECAUTIONS

WARNING: Sitting improperly, out of position or with the seatback reclined too far can take weight off the seat cushion and affect the decision of the passenger sensing system, resulting in serious injury or death in the event of a crash. Always sit upright against your seat back, with your feet on the floor.

WARNING: Do not recline the seat backrest too far as this can cause the occupant to slide under the seatbelt, resulting in personal injury in the event of a crash.

WARNING: Do not place objects higher than the top of the seat backrest. Failure to follow this instruction could result in personal injury or death in the event of a sudden stop or crash.

WARNING: Do not adjust the driver seat or seat backrest when your vehicle is moving. This may result in sudden seat movement, causing the loss of control of your vehicle.

SITTING IN THE CORRECT POSITION

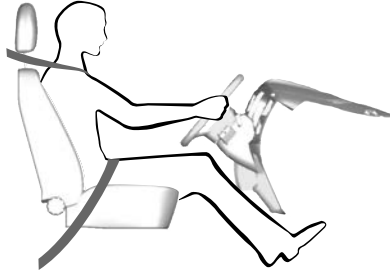

When you use them properly, the seat, head restraint, seatbelt and airbags will provide optimum protection in the event of a crash.

We recommend that you follow these guidelines:

- Sit in an upright position with the base of your spine as far back as possible.
- Do not recline the seat backrest so that your torso is more than 30 degrees from the upright position.

- Adjust the head restraint so that the top of it is level with the top of your head and as far forward as possible. Make sure that you remain comfortable.
- Keep sufficient distance between yourself and the steering wheel. We recommend a minimum of 10 in (25 cm) between your breastbone and the airbag cover.
- Hold the steering wheel with your arms slightly bent.
- Bend your legs slightly so that you can press the pedals fully.
- Position the shoulder strap of the seatbelt over the center of your shoulder and position the lap strap tightly across your hips.

Make sure that your driving position is comfortable and that you can maintain full control of your vehicle.

Front Seats

MANUAL SEATS (IF EQUIPPED)

HEAD RESTRAINT COMPONENTS

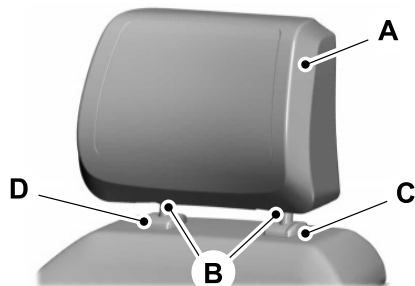

The head restraints consist of:

- A An energy absorbing head restraint.
- B Two steel stems.
- C Guide sleeve adjust and release button.
- D Guide sleeve unlock and remove button (If equipped).

ADJUSTING THE HEAD RESTRAINT

⚠ WARNING: Fully adjust the head restraint before you sit in or operate your vehicle. This will help minimize the risk of neck injury in the event of a crash. Do not adjust the head restraint when your vehicle is moving.

⚠ WARNING: The head restraint is a safety device. Whenever possible it should be installed and properly adjusted when the seat is occupied. Failure to adjust the head restraint properly could reduce its effectiveness during certain impacts.

⚠ WARNING: Adjust the head restraints for all passengers before you drive your vehicle. This will help minimize the risk of neck injury in the event of a crash. Do not adjust the head restraints when your vehicle is moving.

Note: *Adjust the seat backrest to an upright driving position before adjusting the head restraint. Adjust the head restraint so that the top of it is level with the top of your head and as far forward as possible. Make sure that you remain comfortable. If you are extremely tall, adjust the head restraint to its highest position.*

Pull the head restraint up to raise it.

To lower the head restraint:

1. Press and hold the adjust and release button.
2. Push the head restraint down.



For vehicles with tilting head restraints:

1. Adjust the seat backrest to an upright driving or riding position.
2. Pivot the head restraint forward toward your head to the preferred position.

After the head restraint reaches the forward-most tilt position, pivot it forward again to release it to the rearward, untilted position.

Front Seats

Note: Do not attempt to force the head restraint backward after it is tilted. Instead, continue tilting it forward until the head restraint releases to the upright position.

REMOVING THE HEAD RESTRAINT

1. Pull up the head restraint until it reaches the highest adjustment position.
2. Press and hold the adjust and release button and the unlock and remove button.
3. Pull up the head restraint.

Note: You cannot remove head restraints that have audio system speakers.

INSTALLING THE HEAD RESTRAINT

Align the steel stems into the guide sleeves and push the head restraint down until it locks.

MOVING THE SEAT BACKWARD AND FORWARD

 **WARNING:** Make sure the seat fully locks into place by rocking it backward and forward. Not securing the seat into the locked position can be dangerous in a crash and could cause serious personal injury or death.



ADJUSTING THE SEAT BACKREST

(If Equipped)

 **WARNING:** Reclining the seatback can cause an occupant to slide under the seat's seatbelt, resulting in severe personal injuries in the event of a crash.

 **WARNING:** Always drive and ride with your seatback upright and the lap belt snug and low across the hips.

 **WARNING:** Do not place cargo or any objects behind the seat backrest before returning it to the original position. Pull on the seat backrest to make sure that it has fully latched after returning the seat backrest to its original position. An unlatched seat may become dangerous if you stop suddenly or have a crash.

Front Seats



The head restraints consist of:

- A An energy absorbing head restraint.
- B Two steel stems.
- C Guide sleeve adjust and release button.
- D Guide sleeve unlock and remove button (If equipped).

WARNING: Adjust the head restraints for all passengers before you drive your vehicle. This will help minimize the risk of neck injury in the event of a crash. Do not adjust the head restraints when your vehicle is moving.

To raise the head restraint, pull the head restraint up.

To lower the head restraint:

1. Press and hold the adjust and release button.
2. Push the head restraint down.

To tilt the head restraint:



POWER SEATS

HEAD RESTRAINT COMPONENTS

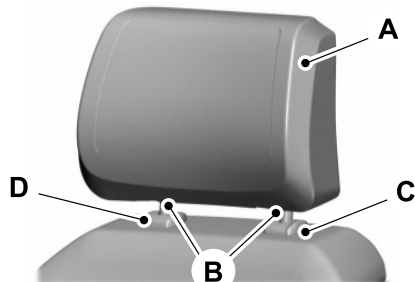

ADJUSTING THE HEAD RESTRAINT

WARNING: Fully adjust the head restraint before you sit in or operate your vehicle. This will help minimize the risk of neck injury in the event of a crash. Do not adjust the head restraint when your vehicle is moving.

WARNING: The head restraint is a safety device. Whenever possible it should be installed and properly adjusted when the seat is occupied. Failure to adjust the head restraint properly could reduce its effectiveness during certain impacts.

Front Seats

1. Adjust the seat backrest to an upright driving or riding position.
2. Pivot the head restraint forward toward your head to the preferred position.

After the head restraint reaches the forward-most tilt position, pivot it forward again to release it to the rearward, untilted position.

Note: Do not attempt to force the head restraint backward after it is tilted. Instead, continue tilting it forward until the head restraint releases to the upright position.

REMOVING THE HEAD RESTRAINT

1. Pull up the head restraint until it reaches its highest position.
2. Press and hold the adjust and release button and the unlock and remove button.
3. Pull up the head restraint.

Note: You cannot remove head restraints that have audio system speakers.

INSTALLING THE HEAD RESTRAINT

Align the steel stems into the guide sleeves and push the head restraint down until it locks.

INSTALLING AND REMOVING A DEVICE

 **WARNING:** Make sure to fully engage the locking lever and properly secure the device. Failure to follow this instruction could result in personal injury in the event of a sudden stop or crash.

The device holder on the back of the front head restraints provides the rear seat occupants with the ability to store and use their personal devices.

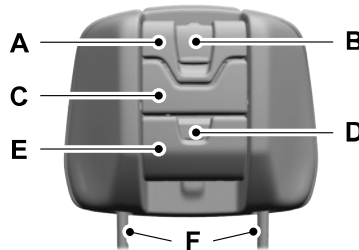

- A Upper door.
- B Locking lever.

- C Middle door.
- D Charge port.
- E Lower door.
- F Head restraint stems.

Installing a Device

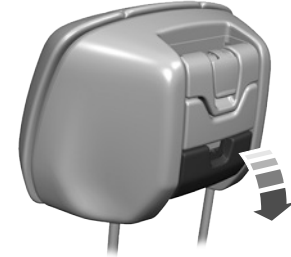

1. Pull the lower door downward. The upper door will automatically rotate upward as the lower door is pulled down.
2. Insert the device between the upper door and the lower door.

Front Seats

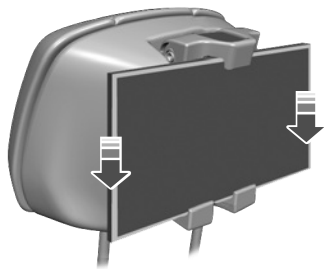

3. Continue to pull downward to fully open the doors to accommodate your device. The doors close around the device when you have it in place.

Note: Make sure the device is securely held once the doors close around it.

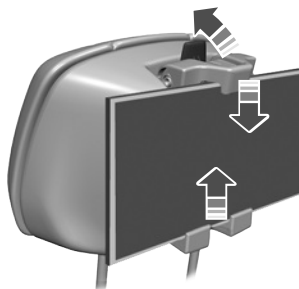

4. Secure the device by rotating the locking lever forward on the upper door.

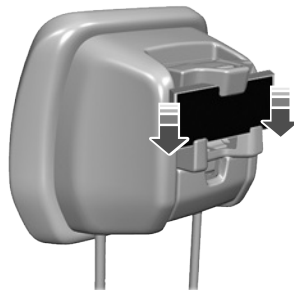

For smaller devices, make sure the device is securely held between the upper door and the middle door. Then rotate the locking lever forward to secure the device in place.

Removing a Device

1. Rotate the tab on the locking lever downward to release the locking lever.
2. Grab both sides of the device and pull downward.
3. Pull downward on the lower door to release the clamp and remove the device from the holder.

MOVING THE SEAT BACKWARD AND FORWARD

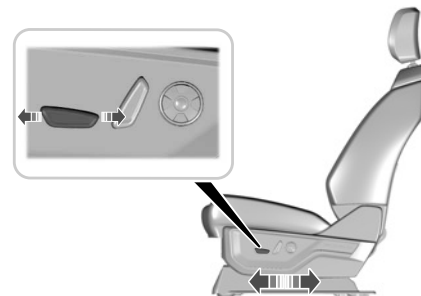

Front Seats

ADJUSTING THE SEAT CUSHION

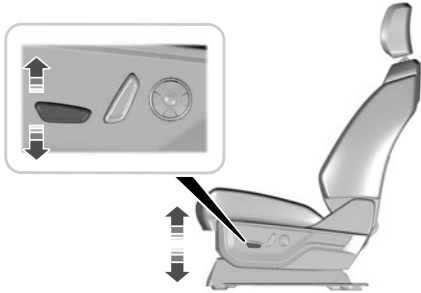

You can also adjust this feature through the touchscreen.

ADJUSTING THE SEAT BACKREST

WARNING: Do not adjust the driver seat or seat backrest when your vehicle is moving. This may result in sudden seat movement, causing the loss of control of your vehicle.

WARNING: Do not place cargo or any objects behind the seatback before returning it to the original position.

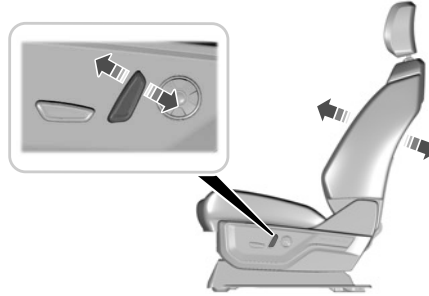

You can also adjust this feature through the touchscreen.

ADJUSTING THE SEAT HEIGHT



ADJUSTING THE LUMBAR SUPPORT

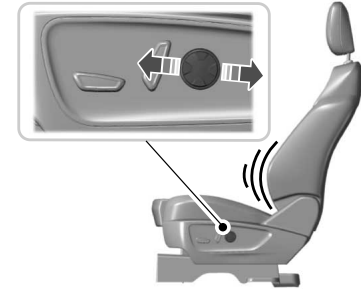

MASSAGE SEATS (IF EQUIPPED)

MASSAGE SEAT LIMITATIONS

The vehicle must be running or in accessory mode to activate the seats.

The passenger side massage is available if the occupant meets the seat sensor weight requirements.

Front Seats

Allow a few seconds for any selection to activate. Selecting a different adjustment cancels the current one in progress. When the seat backrest and cushion are both active, the massage alternates between zones.

ADJUSTING THE MASSAGE SEAT SETTINGS

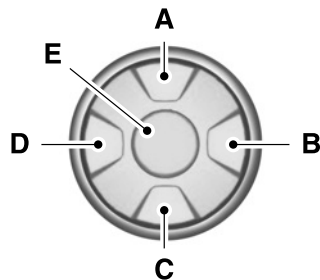

- A Select the previous massage pattern or lumbar area.
- B Decrease the massage or lumbar Intensity.
- C Select the next massage pattern or lumbar area.

- D Increase the massage or lumbar Intensity.
- E Select the massage or lumbar mode.

You can also adjust this feature through the touchscreen.

HEATED SEATS (IF EQUIPPED)

HEATED SEAT PRECAUTIONS

WARNING: Use caution when using the heated seat if you are unable to feel pain to your skin because of advanced age, chronic illness, diabetes, spinal cord injury, medication, alcohol use, exhaustion or other physical conditions. The heated seat could cause burns even at low temperatures, especially if used for long periods of time. Failure to follow this instruction could result in personal injury.

WARNING: Do not poke sharp objects into the seat cushion or seat backrest. This could damage the heated seat element and cause it to overheat. Failure to follow this instruction could result in personal injury.

WARNING: Do not place anything on the seat that blocks the heat, for example a seat cover or a cushion. This could cause the seat to overheat. Failure to follow this instruction could result in personal injury.

Do not:

- Place heavy objects on the seat.
- Operate the heated seat if water or any other liquid spills on the seat. Allow the seat to dry.

SWITCHING THE HEATED SEATS ON AND OFF

The vehicle must be running to use this feature.

Front Seats



Press the heated seat symbol to cycle through the various heat settings and off. More indicator lights indicate warmer settings.

Note: *The heated seats may remain on after you remote start your vehicle, based on your remote start settings. The heated seats may also turn on when you start your vehicle if they were on when you switched your vehicle off.*

Automatic Climate Controlled Seats

(If Equipped)

When you switch the auto setting on, the climate controlled seats switch between the heated seats and ventilated seats to match your climate control setting.

VENTILATED SEATS (IF EQUIPPED)

VENTILATED SEAT PRECAUTIONS

Do not:

- Spill liquid on the front seats. This may cause the air vent holes to become blocked and not work properly.
- Place cargo or objects under the seats. They may block the air intake causing the air vents to not work properly.

SWITCHING THE VENTILATED SEATS ON AND OFF

The vehicle must be running to use this feature.



Press this symbol on the climate controls or the touchscreen to cycle through the various ventilation settings and off. More indicator lights indicate higher fan speeds.

Note: *When you switch the climate control fan speed and the ventilated seats to their maximum settings, the ventilated seats provide increased cooling.*

If the engine falls below 350 RPM while the ventilated seats are on, the feature turns itself off unless the vehicle is in Auto-Start-Stop mode. You may need to reactivate the ventilated seats.

Note: *The ventilated seats may remain on after you remote start your vehicle, based on your remote start settings. The ventilated seats may also turn on when you start your vehicle if they were on when you switched your vehicle off.*

Rear Seats

MANUAL SEATS

HEAD RESTRAINT COMPONENTS

The second row outermost head restraints are not adjustable or foldable.

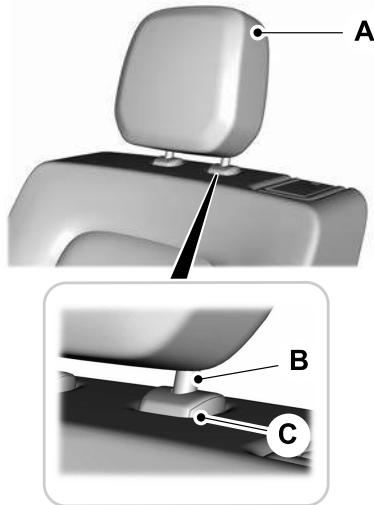

The head restraints consist of:

- A An energy absorbing foam and structure.
- B Two steel stems.
- C Guide sleeve unlock and remove button.

Second and Third Row Center Head Restraint

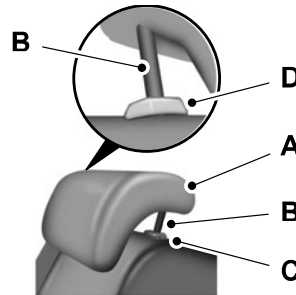

The head restraint consists of:

- A An energy absorbing foam and structure.
- B Two steel stems.

- C Guide sleeve adjust and release button.
- D Guide sleeve unlock and remove button.

Third Row Head Restraints

The third row outermost head restraints are non-adjustable, but you may be able to fold them.

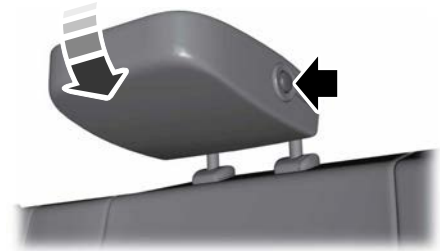

The head restraints consist of:

- A trimmed energy absorbing foam and structure.
- A fold button, if equipped.

Rear Seats

ADJUSTING THE HEAD RESTRAINT

WARNING: Fully adjust the head restraint before you sit in or operate your vehicle. This will help minimize the risk of neck injury in the event of a crash. Do not adjust the head restraint when your vehicle is moving.

WARNING: The head restraint is a safety device. Whenever possible it should be installed and properly adjusted when the seat is occupied. Failure to adjust the head restraint properly could reduce its effectiveness during certain impacts.

WARNING: Adjust the head restraints for all passengers before you drive your vehicle. This will help minimize the risk of neck injury in the event of a crash. Do not adjust the head restraints when your vehicle is moving.

For the second and third row center head restraint, pull the head restraint up to raise it.

To lower the head restraint:

1. Press and hold the guide sleeve adjust and release button.
2. Push the head restraint down.

To fold the third row outermost head restraints:

1. Press the fold button.
2. Pull the head restraint up to place it back to the upright position.

REMOVING THE HEAD RESTRAINT

For the second and third row outermost head restraints:

1. Pull the head restraint up until it reaches its highest position.
2. Press and hold the guide sleeve unlock and remove button.
3. Pull the head restraint up.

For the second and third row center head restraints:

1. Pull the head restraint up until it reaches its highest position.
2. Press and hold guide sleeve adjust and release button and the guide sleeve unlock and remove button.
3. Pull the head restraint up.

INSTALLING THE HEAD RESTRAINT

Align the steel stems into the guide sleeves and push the head restraint down until it locks.

MOVING THE SEAT BACKWARD AND FORWARD

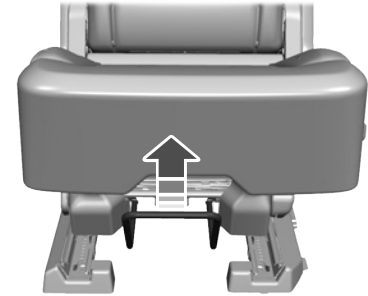

Lift the handle to move the second row seat forward or backward.

Note: Move the seat forward to keep a child in a child restraint close to the front seat occupants. Move the seat to the full rearward position when it is occupied by older children or adults, including children in booster seats.

Rear Seats

ADJUSTING THE SEAT BACKREST

WARNING: Reclining the seatback can cause an occupant to slide under the seat's seatbelt, resulting in severe personal injuries in the event of a crash.



The release handle is on the outermost side of the seat cushion. Lift it to adjust the seat backrest to your preferred position.

Adjusting the Center Seat Backrest



The release strap is on the top of the seat backrest. Lift it to adjust the seat backrest to your preferred position.

FOLDING THE SEAT BACKREST

WARNING: To prevent possible damage to the seat or seatbelts, make sure that the seatbelts are not fastened before folding the seatback.



1. Locate the handle on the outermost side of the seat cushion.
2. Pull up on the handle to fold the seat backrest.

Note: Use caution when folding the seat backrest to the flat position as the seat moves forward when you lift the release handle.

Rear Seats

Folding the Third Row Center Seat

(If Equipped)

WARNING: To prevent possible damage to the seat or seatbelts, make sure that the seatbelts are not fastened before folding the seatback.



The release strap is on the upper right seat backrest. Pull the strap to release the folding seat latch.

Note: Use the same release strap to recline the seat backrest.

UNFOLDING THE SEATS

WARNING: Do not place cargo or any objects behind the seat backrest before returning it to the original position. Pull on the seat backrest to make sure that it has fully latched after returning the seat backrest to its original position. An unlatched seat may become dangerous if you stop suddenly or have a crash.

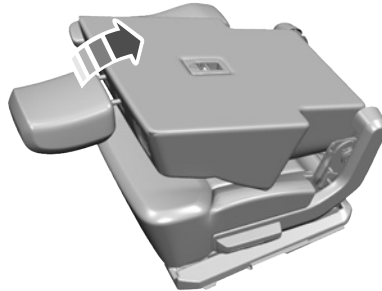

1. Lift the seat backrest toward the rear of the vehicle.
2. Rotate the seat backrest until it engages, locking it in the upright position.

ACCESSING THE THIRD ROW SEATS

(If Equipped)

WARNING: Make sure that the seats and the seat backrests are secure and fully locked. Failure to follow this instruction could result in personal injury or death in a sudden stop or crash.

WARNING: Check under the seat cushion to make sure no cargo or objects are under the seat cushion before returning the seat cushion to its original position, and that the seat cushion locks into place. Failure to do so may prevent the seat from operating properly in the event of a crash, which could increase the risk of serious injury.

WARNING: Do not place cargo or any objects behind the seat backrest before returning it to the original position. Pull on the seat backrest to make sure that it has fully latched after returning the seat backrest to its original position. An unlatched seat may become dangerous if you stop suddenly or have a crash.

Rear Seats

Note: You can move the outermost seats forward to allow access to the seats in the third row.

This feature allows for easier entry and exit to and from the third row seat.



1. Press the button on the top of the seat backrest.
2. Tilt the entire seat forward.
3. Slide the seat forward until it stops.

To return the seat to the seating position, slide the seat rearward while pulling down on the seat backrest until the latch fully engages.

To move the seat further back, pull the lever under the front of the seat and slide it backward.

Note: You can slide the outermost seats forward when using a child restraint.

Adjusting the Second Row Outermost Seats for Easy Exit

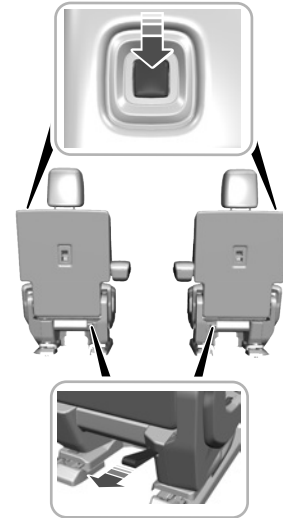

When exiting your vehicle from the third row seats, press the button on the top of the seat backrest. Then, push the seat forward until it stops.

Rear Seats

Note: If your vehicle loses power, pull the release strap at the rear of the seats.

POWER SEATS (IF EQUIPPED)

HEAD RESTRAINT COMPONENTS

The second row outermost head restraints are not adjustable or foldable.

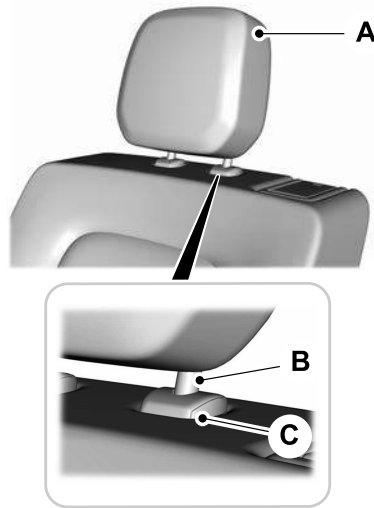

The head restraints consist of:

- A An energy absorbing foam and structure.
- B Two steel stems.
- C Guide sleeve unlock and remove button.

Second and Third Row Center Head Restraint

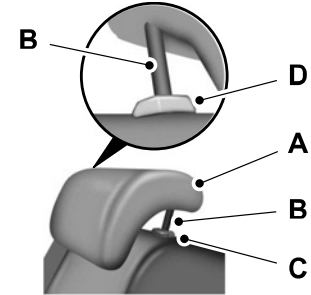

The head restraint consists of:

- A An energy absorbing foam and structure.
- B Two steel stems.
- C Guide sleeve adjust and release button.
- D Guide sleeve unlock and remove button.

Rear Seats

ADJUSTING THE HEAD RESTRAINT

WARNING: Fully adjust the head restraint before you sit in or operate your vehicle. This will help minimize the risk of neck injury in the event of a crash. Do not adjust the head restraint when your vehicle is moving.

WARNING: The head restraint is a safety device. Whenever possible it should be installed and properly adjusted when the seat is occupied. Failure to adjust the head restraint properly could reduce its effectiveness during certain impacts.

WARNING: Adjust the head restraints for all passengers before you drive your vehicle. This will help minimize the risk of neck injury in the event of a crash. Do not adjust the head restraints when your vehicle is moving.

For the second and third-row center head restraint, pull the head restraint up to raise it.

To lower the head restraint:

1. Press and hold the adjust and release button.
2. Push the head restraint down.



Press the button on the head restraint or the button on the overhead console to fold the third-row outermost head restraints. Pull the head restraint up to place it in the upright position.

Note: *These head restraints fold when you press the fold flat button.*

REMOVING THE HEAD RESTRAINT

For the second row outermost head restraints:

1. Pull the head restraint up until it reaches its highest position.
2. Press and hold the guide sleeve unlock and remove button.
3. Pull the head restraint up.

The third row outermost head restraints are fixed and cannot be removed.

For the second and third row center head restraints:

1. Pull the head restraint up until it reaches its highest position.
2. Press and hold guide sleeve adjust and release button and the guide sleeve unlock and remove button.
3. Pull the head restraint up.

INSTALLING THE HEAD RESTRAINT

Align the steel stems into the guide sleeves and push the head restraint down until it locks.

Rear Seats

ADJUSTING THE SEAT BACKREST

WARNING: Do not recline a rear seat on which a child restraint is installed. Failure to follow this instruction could reduce the effectiveness of the child restraint.

The third-row power recline buttons are on the quarter trim panel on each side of the vehicle.

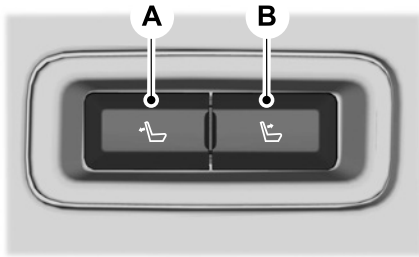

- A Moves the seat backrest rearward.
- B Moves the seat backrest forward.

FOLDING THE SEAT BACKREST

The control buttons are on the left-hand rear quarter trim panel and are accessible from the liftgate area.

Second Row Bench Seats

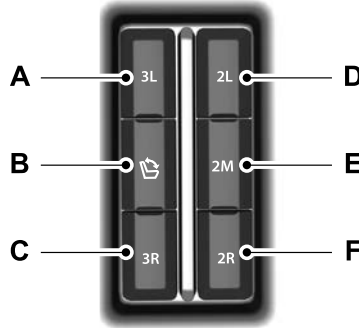

Second Row Captain Chairs

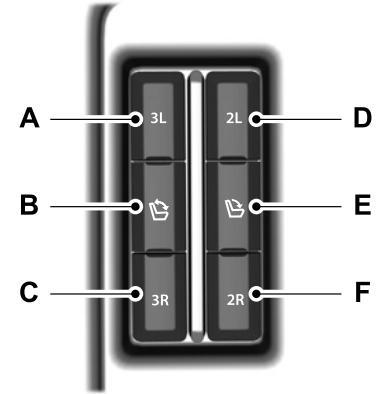

- A Folds the left-hand third-row seat.
- B Folds both third-row seats.
- C Folds the right-hand third-row seat.
- D Folds the left-hand second-row seat.

Rear Seats

- E Folds the second-row bench center seat or both second-row captain chair seats.
- F Folds the right-hand second-row seat.

Note: The power fold seats operate for 10 minutes after you switch the ignition off. The transmission must be in park (P) and the liftgate, or liftgate glass must be open. Similar to the battery saver feature, the power rear seats disable 10 minutes after you switch the ignition off.

Note: Be sure the third-row center head restraint is in the lowered position before you power the rear seats down. For power head restraints, the third-row outermost head restraints fold automatically when you press the fold button. For manual head restraints, the head restraints must be folded with the head restraint fold button prior to folding the seat backrest.

UNFOLDING THE SEAT BACKREST

To return the second-row seat backrest to the original position, rotate the seat backrest up until it latches in the upright position. The seat backrest clicks when it is locked into position.

To return the third-row seat backrest to the original position, press the corresponding control again.

Note: If the third row seat does not completely fold or unfold, press and hold the seat button until the seat folds and unfolds twice.

If the power rear seat is disabled after 10 minutes, you can enable the seat by:

- Opening any door.
- Pressing the unlock button on the key fob.
- Pressing any keyless entry keypad button.
- Switching the ignition on.

Folding Down the Rear Seats to the Load Floor

 **WARNING:** To prevent possible damage to the seat or seatbelts, make sure that the seatbelts are not fastened before folding the seatback.

 **WARNING:** Do not place cargo or any objects behind the seatback before returning it to the original position.

The third-row seats have obstacle detection that prevents the seats from folding or returning if they are obstructed.

HEATED SEATS (IF EQUIPPED)

HEATED SEAT PRECAUTIONS

 **WARNING:** Use caution when using the heated seat if you are unable to feel pain to your skin because of advanced age, chronic illness, diabetes, spinal cord injury, medication, alcohol use, exhaustion or other physical conditions. The heated seat could cause burns even at low temperatures, especially if used for long periods of time. Failure to follow this instruction could result in personal injury.

 **WARNING:** Do not poke sharp objects into the seat cushion or seat backrest. This could damage the heated seat element and cause it to overheat. Failure to follow this instruction could result in personal injury.

Rear Seats



WARNING: Do not place anything on the seat that blocks the heat, for example a seat cover or a cushion. This could cause the seat to overheat. Failure to follow this instruction could result in personal injury.

Do not:

- Place heavy objects on the seat.
- Operate the heated seat if water or any other liquid spills on the seat. Allow the seat to dry.

SWITCHING THE HEATED SEATS ON AND OFF

The vehicle must be running to use this feature.

The rear seat heat controls are on the rear of the center console.



Press the heated seat symbol to cycle through the various heat settings and off. More indicator lights indicate warmer settings.

Note: *The heated seats may remain on after you remote start your vehicle, based on your remote start settings. The heated seats may also turn on when you start your vehicle if they were on when you switched your vehicle off.*

Rear Occupant Alert System

WHAT IS THE REAR OCCUPANT ALERT SYSTEM

The rear occupant alert system monitors vehicle conditions and notifies you to check for rear seat occupants when you switch the ignition off. The notifications can be in the form of warnings inside the vehicle and sounding of the horn if activated for a short period of time.

HOW DOES THE REAR OCCUPANT ALERT SYSTEM WORK

The system monitors the activity of the buckle on the rear seatbelt and the opening and closing of the rear doors to indicate the potential presence of an occupant in the rear seat.

When **Child Seat Installed** is selected, the system monitors only the opening and closing of the rear doors to indicate the potential presence of an occupant in the rear seat.

When **Child Seat Installed** is not selected, the system monitors the rear seatbelt buckle activity and the opening and closing of the rear doors to indicate the potential presence of an occupant in the rear seat.

A message displays in the touchscreen and an audible warning sounds when you switch the ignition off after any of the following conditions have been met:

- A rear door is opened or closed while the ignition is on.
- You switch the ignition on within 15 minutes of a rear door opening and closing.
- You switch the ignition on within 15 minutes of the alert having displayed or sounded.

If you do not open a rear door within a short period of time of the message appearing in the center display, the first audible warning sounding and driver door open to close, the horn sounds for a short period of time.

Note: *Horn sounds only when the **Rear Occupant Alert** is set to **Alert & Horn**. If you change the setting, then there is no horn sound.*

REAR OCCUPANT ALERT SYSTEM PRECAUTIONS



WARNING: On hot days, the temperature inside the vehicle can rise very quickly. Exposure of people or animals to these high temperatures for even a short time can cause death or serious heat related injuries, including brain damage. Small children are particularly at risk.



WARNING: Do not leave children or pets unattended in your vehicle. Failure to follow this instruction could result in personal injury or death.

REAR OCCUPANT ALERT SYSTEM LIMITATIONS

The system does not detect the presence of objects or passengers in the rear seat. It monitors the activity of the buckle on the rear seatbelt and the opening and closing of the rear doors.

Note: *It is possible to receive an alert when there is no rear seat occupant, but alert conditions are met.*

Rear Occupant Alert System

Note: It is possible to receive no alert when there is an occupant in the rear seat, if alert conditions are not met. For example, if a rear seat occupant does not enter the vehicle through a rear door.

REAR OCCUPANT ALERT SYSTEM SETTINGS

1. From the settings menu, press Vehicle.
2. Press Rear Occupant Alert.
3. Select Alert & Horn or Alert Only or Off.

Note: The default setting is Alert Only.

Note: If you choose Alert only, the horn does not sound even when the alert conditions are met.

Note: Performing a system reset causes the system to switch on again.

Switching Child Seat Installed On and Off

When the system is switched on, it monitors the opening and closing of the rear doors to indicate the potential presence of an occupant in the rear seat.

1. From the settings menu, press Vehicle.
2. Press Rear Occupant Alert.

3. Switch Child Seat Installed on or off.

Note: The default setting is on.

Switch the system on when the child restraint is mounted on any of the following:

- Forward facing seat.
- Rear facing seat.
- Toddler in a LATCH system child seat.

Switch the system off when the child is using any of the following:

- Seatbelt.
- Booster seat.

Semiannual Reminder

When you switch the system off, a message appears every six months as a reminder that the system is off. You can switch the system back on or leave it off.

REAR OCCUPANT ALERT SYSTEM INDICATORS



Message
Check rear seats for occupants.

Displays when you switch the power off after the alert conditions are met.

The message displays for a short period of time. Press **Close** to acknowledge and remove the message.

Rear Occupant Alert System

Note: *Depending on your center display system version, the graphic may look different from what you see here.*

REAR OCCUPANT ALERT SYSTEM AUDIBLE WARNINGS

The first audible warning is an alert tone within the vehicle, which sounds when you switch your vehicle off after the alert conditions are met. The warning sounds for a short period of time.

The second audible warning is from the horn. It sounds when you do not open a rear door within a short period of time of the message appearing in the center display, the first audible warning sounding, and driver door open to close. The warning sounds for a short period of time.

Garage Door Opener (If Equipped)

GARAGE DOOR OPENER INTRODUCTION

HomeLink Wireless Control System

The universal garage door opener replaces the common handheld garage door opener with a three-button transmitter integrated into the driver-side sun visor.



How Does The Garage Door Opener Work

The system includes two primary features, a garage door opener and a platform for remote activation of devices within the home. You can program garage doors as well as entry gate operators, security systems, entry door locks and home or office lighting.

Garage Door Opener Limitations

Canadian radio-frequency laws require transmitter signals to time out, or quit, after several seconds – which may not be long enough for HomeLink to pick up the signal. U.S. gate operators time-out in the same manner.

GARAGE DOOR OPENER PRECAUTIONS AND FREQUENCIES

Garage Door Opener Precautions

 **WARNING:** Do not use the system with any garage door opener that does not have the safety stop and reverse feature as required by U.S. Federal Safety Standards (this includes any garage door opener manufactured before April 1, 1982). A garage door opener which cannot detect an object, signaling the door to stop and reverse, does not meet current federal safety standards. Using a garage door opener without these features increases the risk of serious injury or death.

Garage Door Opener (If Equipped)

FCC and RSS-210 Industry Canada Compliance



WARNING: Changes or modifications not expressly approved by the party responsible for compliance could void the user's authority to operate the equipment. The term "IC:" before the radio certification number only signifies that Industry Canada technical specifications were met.

This device complies with Part 15 of the FCC Rules and with RSS-210 of Industry Canada. Operation is subject to the following two conditions: (1) this device may not cause harmful interference, and (2) this device must accept any interference received, including interference that may cause undesired operation.

This equipment complies with FCC radiation exposure limits set forth for an uncontrolled environment. End Users must follow the specific operating instructions for satisfying RF exposure compliance. This transmitter must be at least 8 in (20 cm) from the user and must not be co-located or operating in conjunction with any other antenna or transmitter.

PROGRAMMING THE GARAGE DOOR OPENER

To clear all stored codes in the garage door opener in your vehicle, use the **clear** function. To override one button, use the **reprogram** function.

Note: Make sure that the garage door and security device are free from obstruction when you are programming. Do not program the system with the vehicle in the garage.

Clearing the Garage Door Opener

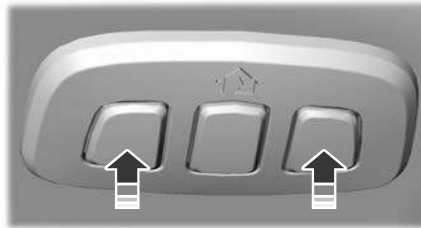

To clear all stored codes in the garage door opener in the vehicle:

1. Press and hold the outer two function buttons simultaneously for approximately 10 seconds until the indicator above the buttons flashes rapidly.
2. When the indicator flashes, release the buttons.

Note: This clears all stored codes. You cannot erase individual buttons.

Note: You can program a maximum of three devices. To change or replace any of the three devices after they have been initially programmed, you must either clear all codes, or reprogram each individual button.

Note: We recommend that upon the sale or lease termination of your vehicle, you erase the programmed function buttons for security reasons.

Reprogramming the Garage Door Opener

If a button on your garage door opener has already been programmed, you can override it. To program a device to a previously trained button:

1. Press and hold the desired button for approximately 20 seconds until the indicator begins to flash.

Garage Door Opener (If Equipped)

- Without releasing the button, proceed to Step 3 of **Programming the Garage Door Opener to your Handheld Transmitter**.

Programming the Garage Door Opener to your Handheld Transmitter

Note: The programming steps below assume you are programming a HomeLink that was not previously programmed. If your HomeLink was previously programmed, you may need to **clear** or **reprogram** your HomeLink buttons.

Note: Put a new battery in the handheld transmitter. This allows for quicker training and accurate transmission of the radio-frequency signal.

Note: Make sure that the garage door and security device are free from obstruction when you are programming. Do not program the system with the vehicle in the garage.



To program your in-vehicle HomeLink function button with your handheld transmitter:

- With your vehicle parked outside of the garage, switch your vehicle on, but do not start your vehicle.
- Press and release one of the three HomeLink function buttons that you would like to program.

Note: The indicator should begin to flash. If the indicator does not flash, press and hold the function button for 20 seconds until the indicator begins to flash.

- Hold your handheld garage door transmitter 1–3 in (2–8 cm) away from the HomeLink button you want to program.

- Press and hold the handheld transmitter button you want to program while watching the indicator on HomeLink. Continue to hold the handheld button until the HomeLink indicator flashes rapidly or is continuously on.

Note: You may need to use a different method if you live in Canada or have difficulties programming your gate operator or garage door opener.

- Press and hold the HomeLink button you programmed for two seconds, then release. You may need to do this twice to activate the door.

Note: If the indicator stays on, the programming is complete.

Note: If the HomeLink indicator flashes rapidly, repeat Step 5.

Note: If your device still does not operate, you must program your garage door.

- To program additional buttons, repeat Steps 1–4.

Note: Make sure you keep the original remote control transmitter for use in other vehicles as well as for future system programming.

Garage Door Opener (If Equipped)

Programming the Garage Door Opener to your Garage Door Opener Motor

Note: Make sure that the garage door and security device are free from obstruction when you are programming. Do not program the system with the vehicle in the garage.



1. Press the learn button on the garage door opener motor and then you have 30 seconds to complete the next two steps.
2. Return to your vehicle.



3. Press and hold one of the three HomeLink function buttons you want to program for two seconds, then release.
4. Repeat Step 3. Depending on your brand of garage door opener, you may need to repeat this sequence a third time.

Programming the Garage Door Opener to your Gate Opener Motor

Gate Operator / Canadian Programming

Canadian radio-frequency laws require transmitter signals to time-out (or quit) after several seconds of transmission – which may not be long enough for HomeLink to pick up the signal during programming. Similar to this Canadian law, some U.S. gate operators are designed to time-out in the same manner.

Note: If programming a garage door opener or gate operator, it is advised that you unplug the device during the **cycling** process to prevent possible overheating.

1. Press and release your handheld transmitter, **every two seconds**, until the HomeLink indicator flashes rapidly or is continuously on.
2. Release the handheld transmitter button.
3. Press and hold the HomeLink function button you want to program for two seconds, then release. You may need to do this twice to activate the door.

Note: If the indicator stays on, the programming is complete.

Note: If the HomeLink indicator flashes rapidly, repeat Step 3.

4. To program additional buttons, repeat Steps 1–4.

USB Ports

LOCATING THE USB PORTS

Data Transfer USB Ports



The USB ports could be in the following locations:

- On the lower instrument panel.
- Inside the center console.

Note: These USB ports can also charge devices.

Note: Not all USB ports in your vehicle have data transfer capabilities.

Note: We recommend using only USB-IF certified cables and adapters. Non-certified cables and adapters may not work.

Charge Only USB Ports



The USB ports could be in the following locations:

- On the lower instrument panel.
- On the upper instrument panel.
- Inside the media bin.

- Inside the center console.
- On the rear of the center console.
- Behind the first row seats.
- In the cargo area.

PLAYING MEDIA USING THE USB PORT



WARNING: Driving while distracted can result in loss of vehicle control, crash and injury. We strongly recommend that you use extreme caution when using any device that may take your focus off the road. Your primary responsibility is the safe operation of your vehicle. We recommend against the use of any hand-held device while driving and encourage the use of voice-operated systems when possible. Make sure you are aware of all applicable local laws that may affect the use of electronic devices while driving.

Connect your device to a data transfer USB port.



Press the audio button on the feature bar.

Select **Sources**.



Select the USB option.



Press to play a track. Press again to pause the track.



Press to skip to the next track.

Press and hold to fast forward through the track.



Press once to return to the beginning of a track. Repeatedly press to return to previous tracks.

Press and hold to fast rewind.

CHARGING A DEVICE

Connect your device to the USB port.

Data Transfer USB Ports



You can charge your device through the data transfer USB port when the touchscreen is on.

USB Ports

Charge Only USB Ports



You can charge your device through the charge only USB port when the vehicle is in accessory mode or when the vehicle is running.

Power Outlet - Vehicles With: 110-120V Power Outlet/120V Power Outlet

WHAT IS THE POWER OUTLET

The power outlet is a socket that connects an electrical device to your vehicle's power supply.

POWER OUTLET PRECAUTIONS

 **WARNING:** Do not keep electrical devices plugged into the power outlet whenever the device is not in use. The outlet provides power when the vehicle is on. Failure to follow this instruction could result in personal injury.

 **WARNING:** Do not use an extension cord or connect multiple devices to the power outlet. Doing so could result in overloading the power outlet. Failure to follow this instruction could result in fire, personal injury or property damage.

Note: The power outlet provides up to 400 Watts when the ignition is on. This wattage is divided between multiple outlets when in use at the same time.

Note: The power outlet turns off when you switch off the ignition, or when the battery voltage drops below 11 volts.

POWER OUTLET LIMITATIONS

You should not use the power outlet for these types of electric devices:

- Cathode ray tube type televisions.
- Motor loads, such as vacuum cleaners, electric saws or other electric power tools and compressor-driven refrigerators.
- Measuring devices which process precise data, such as medical equipment or measuring equipment.
- Other appliances requiring an extremely stable power supply, such as microcomputer-controlled electric blankets or touch sensor lamps.

Note: Some devices may exceed the power rating on the device label when they are initially plugged-in and may require you to press the device power button more than one time in order to allow a soft start. After multiple attempts, if the device remains off, please consider that your device may require more than the available power.

Note: The power outlet provides full available power when the vehicle is in park (P). Power availability may be reduced when the vehicle is in drive (D). If more than one outlet is available in the vehicle, power is divided between the outlets that are in use at the same time.

LOCATING THE POWER OUTLETS

The power outlets are located on the rear of the center console and in the cargo area.

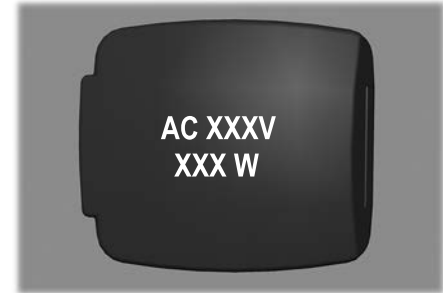

Power Outlet - Vehicles With: 110-120V Power Outlet/120V Power Outlet

POWER OUTLET INDICATORS

The power outlet indicator illuminates to let you know the status of the system.

Indicator Status	Description
On	When the indicator light is on, the outlet is providing power.
Off	When the indicator light is off, there is no power to the outlet.
Flashing	When the indicator light is flashing, the outlet is in a fault mode.

4. With your vehicle on, make sure the indicator light remains on.
5. Make sure your device does not exceed the power limits and then plug in your device.

Note: *If a fault occurs again, your device may exceed the capacity available from the power outlet.*

Fault mode

The power outlet temporarily turns off power if the device exceeds the watt limit.

1. Unplug your device.
2. Switch your vehicle off to let the system cool and reset the fault mode.
3. Switch your vehicle back on, but do not plug your device back in.

Power Outlet - Vehicles With: 12V Power Outlet

WHAT IS THE POWER OUTLET

The power outlet can power devices using a 12 V outlet adapter.

POWER OUTLET PRECAUTIONS



WARNING: Do not plug electrical devices into the power outlets that exceed the maximum power rating. Incorrect use of the power outlets can cause damage not covered by the vehicle warranty, and can result in fire or personal injury.

When you switch the vehicle on, you can use the power outlets to power 12 V appliances with a maximum current rating of 15 A.

To prevent damage to the vehicle's battery:

- Do not use the power outlets over the vehicle capacity of 12 V DC 180 W or a fuse could blow.
- Do not plug in any device that supplies power to the vehicle through the power outlets. This could result in damage to vehicle systems.

- Do not hang any accessory from the accessory plug. Always keep the power outlets caps closed when not in use.
- Do not insert objects other than an accessory plug into the power outlets.
- On the passenger side floor panel.
- 3rd row on the quarter trim panels.

To prevent the battery from running out of charge:

- Do not use the power outlets longer than necessary when the vehicle is off.
- Do not leave devices plugged in overnight or when you park your vehicle for extended periods.
- Using devices for extended periods may require starting and running the engine to recharge the battery.

LOCATING THE POWER OUTLETS

Power outlets may be in the following locations:

- On the lower instrument panel.
- Inside the center console.
- On the front of the center console.
- On the rear of the center console.
- In the cargo area.

Wireless Accessory Charger (If Equipped)

WHAT IS THE WIRELESS ACCESSORY CHARGER

The wireless accessory charger allows you to charge one compatible Qi wireless charging device on the charging area.

WIRELESS ACCESSORY CHARGER PRECAUTIONS



WARNING: Wireless charging devices can affect the operation of implanted medical devices, including cardiac pacemakers. If you have any implanted medical devices, we recommend that you consult with your physician.



WARNING: Remove all metal objects like coins and keys from the charging surface and remove any metal objects attached to your mobile phone before placing the device on the charging surface. Some mobile devices or cases may attract metal objects. Metal objects on the

charging surface or attached to the phone may become hot while charging is active. If an object is left on or near the charging surface or attached to the phone while the device is charging, let the objects cool before removing to prevent personal injury.

Keep the charging area clean and remove foreign objects prior to charging a device.

Do not place items with a magnetic strip or radio-frequency identification chip, for example passports, parking tickets, transportation passes or credit cards, near the charging area when charging a device. Damage could occur to the magnetic strip or radio-frequency identification chip.

Do not place metal objects, for example remote controls, coins and candy wrappers, on or near the charging area when charging a device. Metal objects may heat up and degrade the charging performance, in addition to causing interruptions in charging.

Charging could be interrupted, degraded, or could stop if any of the following occur:

- The system detects a foreign object.
- The device is misaligned on the charging area.
- The device moves on the active charging area when the vehicle is in motion.

- The vehicle ambient temperature is too high.
- You attempt to charge a non-Qi compatible device on the wireless charger.

Note: *During charging, the device and the charger could heat up, this is normal. If the battery gets hotter than usual, the device may stop charging.*

LOCATING THE WIRELESS ACCESSORY CHARGER



The charging area is on the center console or in the media bin below the instrument panel.

CHARGING A WIRELESS DEVICE

Place the device on the center of the charging surface with the charging side down. The charging stops after your device reaches a full charge.

You can use the charger when the vehicle is in accessory mode, when the vehicle is running or when the touchscreen is on.

Wireless Accessory Charger (If Equipped)



Displays on the status bar when wireless charging is in progress.



Displays on the status bar when wireless charging has been interrupted.

Note: *The charging performance may be affected if your device is in a case. It may be necessary to remove the case to wirelessly charge your device.*

Note: *Software and firmware updates may affect device compatibility, including the use of unofficial software or firmware. You should verify charging functionality with your specific devices in-vehicle.*

Storage

OVERHEAD STORAGE

OPENING THE OVERHEAD STORAGE COMPARTMENT

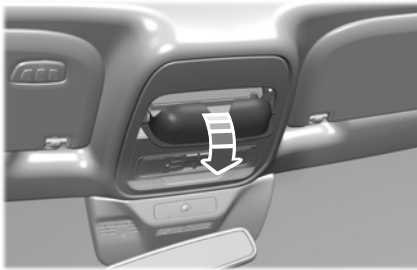

Press near the rear edge of the door to open it.

GLOVE COMPARTMENT

OPENING THE GLOVE COMPARTMENT



Pull the latch to the left to open.

CENTER CONSOLE

OPENING THE CENTER CONSOLE

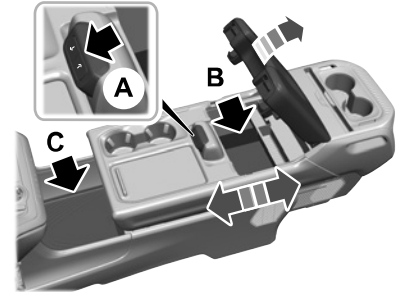

- A Console slide buttons.
- B Main bin.
- C Secondary bin.

Pull up on the armrest handle to access the center console main bin.

Press the forward slide button to move the upper portion of the center console. This allows access to the secondary bin.

Storage

UNDER FLOOR STORAGE

LOCATING THE REAR UNDER FLOOR STORAGE

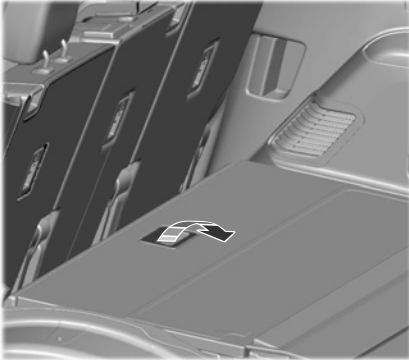



Starting and Stopping the Engine

STARTING AND STOPPING THE ENGINE – PRECAUTIONS

 **WARNING:** Extended idling at high engine speeds can produce very high temperatures in the engine and exhaust system, creating the risk of fire or other damage.

 **WARNING:** Do not park, idle or drive your vehicle on dry grass or other dry ground cover. The emission system heats up the engine compartment and exhaust system, creating the risk of fire.

 **WARNING:** Do not start the engine in a closed garage or in other enclosed areas. Exhaust fumes are toxic. Always open the garage door before you start the engine. Failure to follow this instruction could result in personal injury or death.

 **WARNING:** Do not use starting fluid, for example ether, in the air intake system. Such fluid could cause immediate explosive damage to the engine and possible personal injury.

 **WARNING:** Exhaust leaks may result in entry of harmful and potentially lethal fumes into the passenger compartment. If you smell exhaust fumes inside your vehicle, have your vehicle inspected immediately. Do not drive if you smell exhaust fumes.

The powertrain control system meets all Canadian interference-causing equipment standard requirements regulating the impulse electrical field or radio noise.

If you stop your vehicle and leave the engine idling for long periods, we recommend that you do one of the following:

- Open the windows at least 1 in (2.5 cm).
- Set your climate control to outside air.

PUSH BUTTON IGNITION SWITCH



Switching the Ignition Off

When the ignition is on or in accessory mode, press the push button ignition switch once without your foot on the brake pedal.

Switching the Ignition to Accessory Mode

When the ignition is off, press the push button ignition switch once without your foot on the brake pedal.

All electrical circuits and accessories are operational and the warning lamps and indicators illuminate.

Note: *Your vehicle has a battery saver feature that shuts your vehicle off when it detects a certain amount of battery drain, or after approximately 30 minutes of inactivity in accessory mode.*

Note: *The system may not function if the passive key is close to metal objects or electronic devices, for example keys or a cell phone.*

Note: *You need a valid passive key inside your vehicle to switch the ignition on and start the engine.*

Starting and Stopping the Engine

STARTING THE ENGINE

STARTING A GASOLINE ENGINE

Before starting your vehicle, check the following:

- Make sure that the parking brake is on.
- Make sure that the transmission is in park (P).

1. Fully press the brake pedal.

Note: Do not touch the accelerator pedal.



2. Press the push button ignition switch.

Note: The engine may continue cranking for up to 15 seconds or until it starts.

Note: The engine takes longer to start at lower temperatures. It may crank for several seconds when very cold.

RESTARTING THE ENGINE AFTER STOPPING IT

The system allows you to start the engine within 10 seconds of switching it off, even if it does not detect a valid passive key.

Within 10 seconds of switching the engine off, fully press the brake pedal and press the push button ignition switch. After 10 seconds, you can no longer start the engine if the system does not detect a valid passive key.

When you start the engine, it remains running until you press the push button ignition switch, even if your vehicle does not detect a valid passive key. If you open and close a door when the engine is running, the system searches for a valid passive key.

ENGINE BLOCK HEATER (IF

EQUIPPED)

ENGINE BLOCK HEATER PRECAUTIONS



WARNING: Failure to follow engine block heater instructions could result in property damage or serious personal injury.



WARNING: Do not use your heater with ungrounded electrical systems or two-pronged adapters. There is a risk of electrical shock.



WARNING: Do not fully close the hood, or allow it to drop under its own weight when using the engine block heater. This could damage the power cable and may cause an electrical short resulting in fire, injury and property damage.

We recommend that you do the following for a safe and correct operation:

- Use a 16-gauge outdoor extension cord that is product certified by Underwriter's Laboratory (UL) or Canadian Standards Association (CSA). This extension cord must be suitable for use outdoors, in cold temperatures, and be clearly marked Suitable for Use with Outdoor Appliances. Do not use an indoor extension cord outdoors. This could result in an electric shock or become a fire hazard.
- Use as short an extension cord as possible.
- Do not use multiple extension cords.

Starting and Stopping the Engine

- Make sure that when in operation, the extension cord plug and engine block heater cord plug connections are free and clear of water. This could cause an electric shock or fire.
- If the engine block heater cord is under the hood, do not remove the wiring from its original location. Do not close the hood on the extension wiring.
- Park your vehicle in a clean area, clear of combustible materials.
- Firmly connect the engine block heater cord and the extension cord.
- Check the extension cord for heat anywhere when the system has been operating for approximately 30 minutes.
- Unplug and properly stow the system before starting and driving your vehicle. The protective cover seals the terminals of the engine block heater cord plug when not in use.
- Check the engine block heater system for proper operation before winter.

HOW DOES THE ENGINE BLOCK HEATER WORK

The engine block heater warms the engine coolant. This allows the climate control system to quickly respond. The equipment includes a heater element installed in the engine block and a wire harness. You can connect the system to a grounded 110 volt AC electrical source.

Note: *The engine block heater is most effective when outdoor temperatures are below 0°F (-18°C). We recommend the use of engine block heater to improve engine cold start performance.*

USING THE ENGINE BLOCK HEATER

Make sure the receptacle terminals are clean and dry prior to use. Clean them with a dry cloth if necessary.

The heater uses 0.4 to 1.0 kilowatt-hours of energy per hour of use. The system does not have a thermostat. It achieves maximum temperature after approximately three hours of operation. Using the engine block heater longer than three hours does not improve system performance and unnecessarily uses electricity.

STOPPING THE ENGINE

STOPPING THE ENGINE WHEN YOUR VEHICLE IS STATIONARY

1. Shift into park (P).
2. Apply the parking brake.
3. Wait until the engine reaches idle speed.



4. Press the push button ignition switch.

STOPPING THE ENGINE WHEN YOUR VEHICLE IS MOVING



WARNING: Switching off the engine when your vehicle is still moving results in a significant decrease in braking assistance. Higher effort is required to apply the brakes and to stop your vehicle. A significant decrease in steering assistance could also occur. The steering does not lock, but

Starting and Stopping the Engine

higher effort could be required to steer your vehicle. When you switch the ignition off, some electrical circuits, for example airbags, also turn off. If you unintentionally switch the ignition off, shift into neutral (N) and restart the engine.

Only in case of emergency, do the following:



1. Press and hold the push button ignition switch until the engine stops, or press it three times within two seconds.
2. Shift into neutral (N) and use the brakes to safely bring your vehicle to a complete stop.
3. Shift into park (P).
4. Apply the parking brake.

AUTOMATIC ENGINE STOP

WHAT IS AUTOMATIC ENGINE STOP

Automatic engine stop is a feature that switches the engine off if it has been idling for an extended period to help you save fuel.

HOW DOES AUTOMATIC ENGINE STOP WORK

Automatic engine stop turns the engine off. The ignition also turns off in order to save battery power. Before the engine shuts down, a message appears in the information display showing a timer counting down. If you do not intervene within 30 seconds, the engine shuts down. Another message appears in the information display to inform you that the engine has shut down in order to save fuel. Start your vehicle as you normally do.

SWITCHING AUTOMATIC ENGINE STOP ON AND OFF

1. From the settings menu, press Vehicle.
2. Switch 30min Max Idle on or off.

Note: *You cannot permanently switch off the automatic shutdown. If you switch it off, it turns on each time you switch the ignition on.*

OVERRIDING AUTOMATIC ENGINE STOP

You can stop the engine shutdown, or reset the timer, at any point before the 30-second countdown has expired by doing any of the following:

- Pressing the brake pedal or accelerator pedal.
- Pressing the **OK** or **RESET** button during the countdown.

Note: *You cannot permanently switch off the automatic engine shutdown feature. When you switch it off temporarily, it turns on at the next ignition cycle.*

ACCESSING THE PASSIVE KEY BACKUP POSITION

If you are unable to start your vehicle, do the following:

Starting and Stopping the Engine

Vehicles without armrest



1. With the buttons facing up, insert the passive key into the backup slot.
2. With the key in this position, press the brake pedal, then press the push button ignition switch to switch the ignition on and start your vehicle.

Vehicles with armrest

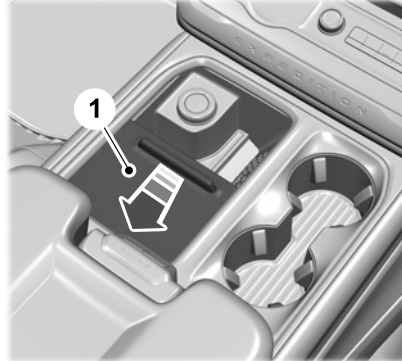

1. Access the backup slot.

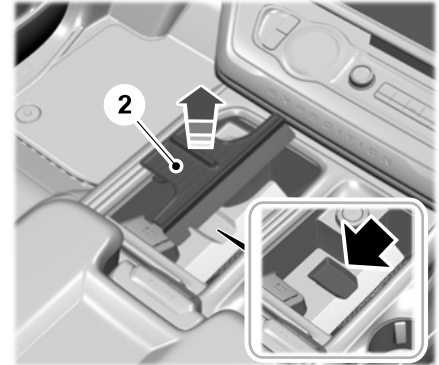

2. With the buttons facing up, place the passive key into the backup slot.
3. With the key in this position, press the brake pedal, then press the push button ignition switch to switch the ignition on and start your vehicle.

Starting and Stopping the Engine

STARTING AND STOPPING THE ENGINE – TROUBLESHOOTING

STARTING AND STOPPING THE ENGINE – WARNING LAMPS

Malfunction Indicator Lamp



If it illuminates when the engine is running, the on-board diagnostics system is detecting a malfunction of the vehicle emission control system.

If it flashes, engine misfire could be occurring. Increased exhaust gas temperatures could damage the catalytic converter or other vehicle components. Avoid heavy acceleration and deceleration, and have your vehicle checked as soon as possible.

Powertrain Warning Lamp



If it illuminates when the engine is running, this indicates a powertrain or four-wheel drive fault. If it flashes when you are driving, immediately reduce the vehicle speed. Avoid heavy acceleration and deceleration, and have your vehicle checked as soon as possible.

If both lamps illuminate when the engine is running, stop your vehicle as soon as it is safe to do so. Continuing to drive your vehicle could cause reduced power or the engine to stop. Switch the ignition off and attempt to restart the engine. Have your vehicle checked as soon as possible.

Oil Pressure Warning Lamp



It illuminates when you switch the ignition on. If it illuminates when the engine is running, this indicates a malfunction. Stop your vehicle and switch the engine off. Check the engine oil level. If the oil level is sufficient, this indicates a system malfunction. Have your vehicle checked as soon as possible.

STARTING AND STOPPING THE ENGINE – INFORMATION MESSAGES

Message	Action
Cranking Time Exceeded	Displays if you exceed the starting time limit. You cannot attempt to start the engine for 15 minutes. If you cannot start the engine after 15 minutes passes, have your vehicle immediately checked.
Starting System Fault	Displays if you are unable to start your vehicle with a correctly coded key. The system has detected a fault that requires service. Have your vehicle checked as soon as possible.
No Key Detected	Displays if the system does not detect a valid passive key.

Starting and Stopping the Engine

STARTING AND STOPPING THE ENGINE – FREQUENTLY ASKED QUESTIONS

Why is the engine idle speed high when I start the engine?

- The speed the engine idles immediately after starting is optimized to minimize vehicle emissions and maximize cabin comfort and fuel economy.

Why is the engine not cranking?

The engine will not crank if:

- The system does not detect a valid passive key.
- The passive key battery has no charge.
- The vehicle battery does not have sufficient charge.
- The brake pedal is not pressed for automatic transmissions or the clutch pedal is not pressed for manual transmissions.
- The transmission is not in the park (P) or neutral (N) for automatic transmissions.
- The starting system has been disabled after multiple attempts of starting the engine.

What should I do if the starting system is disabled?

- You can only attempt to start the engine for a set number of times before the starting system temporarily disables. If you exceed the limit, a message may appear and you need to wait at least 15 minutes to start the engine again.

What should I do if the engine does not start?

- If you cannot start the engine after three attempts, wait 10 seconds and do the following:
 1. Fully press the brake pedal for automatic transmissions or clutch pedal for manual transmissions.

Note: *Make sure that the parking brake is applied.*

Note: *Make sure that the transmission is in park (P) or neutral (N) for automatic transmissions.*

2. Fully press and hold the accelerator pedal.
3. Press the push button ignition switch. See **Push Button Ignition Switch** (page 173).

Note: *The engine cranks for a short period of time and then stops.*

4. Release the accelerator pedal.
5. Press the push button ignition switch. See **Push Button Ignition Switch** (page 173).

Why do I experience different driving characteristics?

- If you disconnect the battery, your vehicle may exhibit some unusual driving characteristics for about 5 mi (8 km) after you reconnect it. This is because the engine management system must realign itself with the engine. You can disregard any unusual driving characteristics during this period.

Why does the system not detect a passive key?

- If the system does not detect a passive key and you are unable to start the engine, insert the passive key into the backup position and press the push button ignition switch to start the engine. See **Accessing the Passive Key Backup Position** (page 176).

Starting and Stopping the Engine

What happens when driving the vehicle without a valid key?

- A message displays in the instrument cluster if no valid key is detected, when you exit your vehicle with a key, after the last front door is closed and your keyless vehicle is in run, indicating your vehicle is still on. The horn sounds if you have driven the vehicle and reached a speed of 16 mph (25 km/h) and the above conditions are met.

You can switch the key detection audible alert on or off. See **Keyless Entry Settings** (page 76).

Auto-Start-Stop

WHAT IS AUTO-START-STOP

The system is designed to help reduce fuel consumption and CO₂ emissions by stopping the engine when it is idling, for example at traffic lights.

AUTO-START-STOP PRECAUTIONS



WARNING: Apply the parking brake, shift into park (P), switch the ignition off and remove the key before you leave your vehicle. Failure to follow this instruction could result in personal injury or death.



WARNING: Apply the parking brake, shift into park (P), switch the ignition off and remove the key before you open the hood or have any service or repair work completed. If you do not switch the ignition off, the engine could restart at any time. Failure to follow this instruction could result in personal injury or death.

SWITCHING AUTO-START-STOP ON AND OFF

The system turns on when you switch the ignition on.



Press the button to switch the system off.

Note: *OFF* illuminates in the switch.

Note: *Deactivating the system using the button lasts only one key cycle.*

Press the button again to switch the system back on.

Note: *The system turns off if it detects a malfunction. If the system malfunctions, have your vehicle checked as soon as possible.*

STOPPING THE ENGINE

Stop your vehicle, keep your foot on the brake pedal and the transmission in drive (D).

RESTARTING THE ENGINE

Release the brake pedal or press the accelerator pedal.

A message appears in the instrument cluster display if the system requires you to take action.

AUTO-START-STOP INDICATORS



WARNING: The system may require the engine to automatically restart when the auto-start-stop indicator illuminates green or flashes amber. Failure to follow this instruction could result in personal injury.



The auto-start-stop indicator illuminates green when the engine stops. It flashes amber and a message appears when you need to take action. It illuminates gray when the system is not available.



The auto-start-stop indicator illuminates gray with a strikethrough when you disabled the feature.

Auto-Start-Stop

AUTO-START-STOP – TROUBLESHOOTING

AUTO-START-STOP – INFORMATION MESSAGES

A message appears in the instrument cluster display if the system requires you to take action.

Message	Condition	Action
Auto StartStop Press Brake to Start Engine	The system needs to restart the engine but requires your confirmation.	Press the brake pedal to restart the engine.
Auto StartStop Press a Pedal to Start Engine	The system needs to restart the engine but requires your confirmation.	Press the brake pedal or the accelerator pedal to restart the engine.

Auto-Start-Stop

AUTO-START-STOP – FREQUENTLY ASKED QUESTIONS

Why does the engine not always stop when I expect it to?

The system is designed to work in a way that complements other vehicle systems, allowing them to operate at optimum performance.

The system does not stop the engine if:

- The driver door is open.
- Your vehicle is at high altitude.
- The heated windshield is on.
- The engine is warming up.
- The outside temperature is too low or too high.
- The battery charge is low.
- The battery temperature is outside the optimal operating range.
- The engine is required to run to maintain interior climate and reduce fogging.

Why does the engine sometimes restart when I do not expect it to?

The system is designed to work in a way that complements other vehicle systems, allowing them to operate at optimum performance.

The system restarts the engine if:

- You switch the heated windshield on.
- You switch maximum defrost on.
- Your vehicle starts to roll downhill in neutral.
- The engine is required to run to maintain adequate brake system assistance.
- The engine is required to run to maintain interior climate and reduce fogging.

Can I permanently switch the system off?

No. The system plays an important role in reducing the fuel consumption and the CO₂ emissions.

Will the frequent engine starts cause parts to wear out?

Your vehicle has an enhanced battery and starter motor that are designed for the increased number of engine starts.

Fuel and Refueling

FUEL AND REFUELING PRECAUTIONS



WARNING: Fuels can cause serious injury or death if misused or mishandled.



WARNING: Fuel may contain benzene, which is a cancer-causing agent.



WARNING: Read and follow all the instructions on the pump island.



WARNING: When refueling always shut the engine off and never allow sparks or open flames near the fuel tank filler valve. Never smoke or use a cell phone while refueling. Fuel vapor is extremely hazardous under certain conditions. Avoid inhaling excess fumes.

Follow these guidelines when refueling:

- Extinguish all smoking materials and any open flames before refueling your vehicle.
- Switch the engine off before refueling.

- Automotive fuels can be harmful or fatal if swallowed. Fuel is highly toxic and if swallowed can cause death or permanent injury. If fuel is swallowed immediately call a physician, even if no symptoms are immediately apparent. The toxic effects of fuel may not be apparent for hours.
- Avoid inhaling fuel vapors. Inhaling fuel vapor can lead to eye and respiratory tract irritation. In severe cases, excessive or prolonged breathing of fuel vapor can cause serious illness and permanent injury.
- Avoid getting fuel in your eyes. If you splash fuel in your eyes, immediately remove contact lenses, if worn, flush with water for 15 minutes and seek medical attention. Failure to seek proper medical attention could lead to permanent injury.
- Fuels can be harmful if absorbed through the skin. If you splash fuel on your skin, clothing or both, promptly remove contaminated clothing and thoroughly wash your skin with soap and water. Repeated or prolonged skin contact causes skin irritation.
- Be particularly careful if you are taking Antabuse or other forms of Disulfiram for the treatment of alcoholism. Breathing fuel vapors could cause an adverse reaction, serious personal injury or sickness. Immediately call a physician if you experience any adverse reactions.

FUEL QUALITY

SELECTING THE CORRECT FUEL

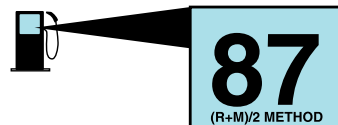

Fuel and Refueling

Your vehicle operates on regular unleaded gasoline with a minimum pump (R+M)/2 octane rating of 87.

Some fuel stations, particularly those in high altitude areas, offer fuels posted as regular unleaded gasoline with an octane rating below 87. The use of these fuels could result in engine damage that will not be covered by the vehicle Warranty.

For best overall vehicle and engine performance, premium fuel with an octane rating of 91 or higher is recommended. The performance gained by using premium fuel is most noticeable in hot weather as well as other conditions, for example when towing a trailer. See **Towing a Trailer** (page 335).

Do not be concerned if the engine sometimes knocks lightly. However, if the engine knocks heavily while using fuel with the recommended octane rating, contact an authorized dealer to prevent any engine damage.

We recommend Top Tier detergent gasolines, where available to help minimize engine deposits and maintain optimal vehicle and engine performance.

For additional information, visit www.toptiergas.com.

Note: *Use of any fuel for which the vehicle was not designed can impair the emission control system, cause loss of vehicle performance, and cause damage to the engine which may not be covered by the vehicle Warranty.*

Do not use:

- Diesel fuel.
- Fuels containing kerosene or paraffin.
- Fuel containing more than 15% ethanol (E15) or E85 fuel.
- Fuels containing methanol.
- Fuels containing metallic-based additives, including manganese-based compounds.
- Fuels containing the octane booster additive, methylcyclopentadienyl manganese tricarbonyl (MMT).
- Leaded fuel, using leaded fuel is prohibited by law.

The use of fuels with metallic compounds such as methylcyclopentadienyl manganese tricarbonyl, which is a manganese-based fuel additive, will impair engine performance and affect the emission control system.

LOCATING THE FUEL FILLER FUNNEL

The fuel filler funnel is in the rear floor compartment with the jack and tools.

RUNNING OUT OF FUEL

FILLING A PORTABLE FUEL CONTAINER



WARNING: Flow of fuel through a fuel pump nozzle can produce static electricity. This can cause a fire if you are filling an ungrounded fuel container.

Use the following guidelines to avoid electrostatic charge build-up, which can produce a spark, when filling an ungrounded fuel container:

- Only use an approved fuel container to transfer fuel to your vehicle. Place the container on the ground when filling it.
- Do not fill a fuel container when it is inside your vehicle (including the cargo area).

Fuel and Refueling

- Keep the fuel pump nozzle in contact with the fuel container when filling it.
- Do not use a device that holds the fuel pump nozzle lever in the fill position.

ADDING FUEL FROM A PORTABLE FUEL CONTAINER

 **WARNING:** Do not insert the nozzle of a fuel container or an aftermarket funnel into the fuel filler neck. This may damage the fuel system filler neck or its seal and cause fuel to run onto the ground.

 **WARNING:** Do not pry open the fuel tank filler valve. This could damage the fuel system. Failure to follow this instruction could result in fire, personal injury or death.

 **WARNING:** Do not dispose of fuel in the household refuse or the public sewage system. Use an authorized waste disposal facility.

When refueling the vehicle fuel tank from a fuel container, use the fuel filler funnel included with your vehicle. See **Locating the Fuel Filler Funnel** (page 185).

Note: Do not use aftermarket funnels as they may not work with the capless fuel system and can damage it.

When refueling the vehicle fuel tank from a fuel container, do the following:

1. Fully open the fuel filler door.



2. Fully insert the fuel filler funnel into the fuel filler inlet.
3. Add fuel to your vehicle from the fuel container.
4. Remove the fuel filler funnel.
5. Fully close the fuel filler door.

6. Clean the fuel filler funnel and place it back in your vehicle or correctly dispose of it.

Note: If your vehicle runs out of fuel add a minimum of 1.3 gal (5 L) of fuel to restart the engine.

Note: You may need to switch the ignition from off to on several times after refueling to allow the fuel system to pump the fuel from the tank to the engine. When restarting, cranking time takes a few seconds longer than normal.

Note: Extra funnels can be purchased from an authorized dealer if you choose to dispose of the funnel.

Fuel and Refueling

REFUELING

REFUELING SYSTEM OVERVIEW

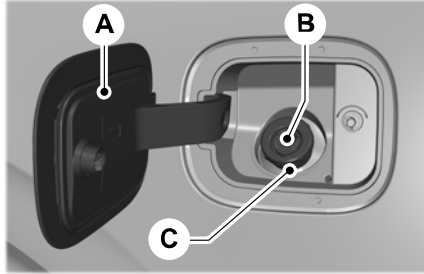

- A Fuel filler door.
- B Fuel filler inlet.
- C Fuel tank filler pipe.

REFUELING YOUR VEHICLE

⚠ WARNING: When refueling always shut the engine off and never allow sparks or open flames near the fuel tank filler valve. Never smoke or use a cell phone while refueling. Fuel vapor is extremely hazardous under certain conditions. Avoid inhaling excess fumes.

⚠ WARNING: Fuel vapor burns violently and a fuel fire can cause severe injuries.

⚠ WARNING: The fuel system may be under pressure. If you hear a hissing sound near the fuel filler inlet, do not refuel until the sound stops. Otherwise, fuel may spray out, which could cause serious personal injury.

⚠ WARNING: Keep children away from the fuel pump. Never let children pump fuel.

⚠ WARNING: Do not pry open the fuel tank filler valve. This could damage the fuel system. Failure to follow this instruction could result in fire, personal injury or death.

⚠ WARNING: Stay outside your vehicle and do not leave the fuel pump unattended when refueling your vehicle.

⚠ WARNING: Do not remove the fuel pump nozzle from its fully inserted position when refueling.

⚠ WARNING: Stop refueling when the fuel pump nozzle automatically shuts off for the first time. Failure to follow this will fill the expansion space in the fuel tank and could lead to fuel overflowing.

⚠ WARNING: Do not overfill the fuel tank. The pressure in an overfilled tank may cause leakage and lead to fuel spray and fire.

⚠ WARNING: Wait at least five seconds before removing the fuel pump nozzle to allow any residual fuel to drain into the fuel tank.

1. Fully open the fuel filler door.
2. Select the correct fuel pump nozzle for your vehicle.

Fuel and Refueling

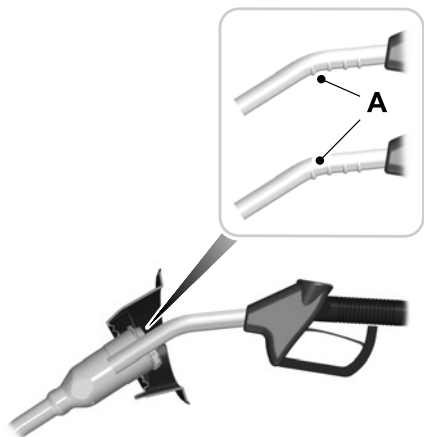

3. Insert the fuel pump nozzle up to the first notch. Keep the fuel pump nozzle resting on the fuel tank filler pipe.

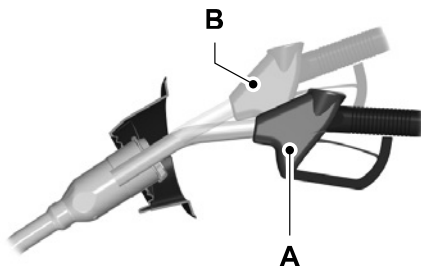

4. Hold the fuel pump nozzle in position A when refueling. Holding the fuel pump nozzle in position B can affect the flow of fuel and shut off the fuel pump nozzle before the fuel tank is full.

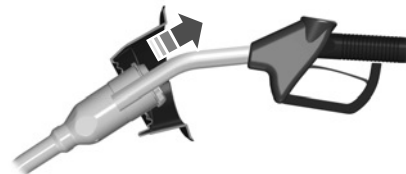

5. When the pump shuts off, wait five seconds, then raise the fuel pump nozzle and slowly remove it.
6. Fully close the fuel filler door.

Note: Do not attempt to start the engine if you have filled the fuel tank with incorrect fuel. Incorrect fuel use could cause damage not covered by the vehicle Warranty. Have your vehicle immediately checked.

FUEL TANK CAPACITY

Capacities

Variant	Quantity
Base.	23.6 gal (89.3 L)
Expedition MAX.	27.8 gal (105.2 L)

Fuel and Refueling

Advertised Capacity

The advertised capacity is the maximum amount of fuel that you can add to the fuel tank when the fuel gauge indicates empty.

In addition, the fuel tank contains an empty reserve. The empty reserve is an unspecified amount of fuel that remains in the fuel tank when the fuel gauge indicates empty.

Note: *When refueling your vehicle after the fuel gauge indicates empty, you might not be able to refuel the full amount of the advertised capacity due to the empty reserve still present in the fuel tank.*

FUEL AND REFUELING – TROUBLESHOOTING

FUEL AND REFUELING – WARNING LAMPS



If it illuminates when you are driving, refuel as soon as possible.

FUEL AND REFUELING – INFORMATION MESSAGES

Refueling System Warning

If the fuel tank filler valve does not fully close, a message could appear in the instrument cluster display.

Message
Check Fuel Fill Inlet

If the message appears, do the following:

1. Stop your vehicle as soon as it is safe to do so and switch the engine off.
2. Shift into park (P) or neutral (N).
3. Apply the parking brake.
4. Fully open the fuel filler door.
5. Check the fuel tank filler valve for any debris that may be restricting its movement.
6. Remove any debris from the fuel tank filler valve.

7. Fully insert a fuel pump nozzle or the fuel filler funnel provided with your vehicle into the fuel filler pipe. See **Locating the Fuel Filler Funnel** (page 185). This action should dislodge any debris that may be preventing the fuel tank filler valve from fully closing.
8. Remove the fuel pump nozzle or fuel filler funnel from the fuel filler pipe.
9. Fully close the fuel filler door.

Note: *The message may not immediately reset. If the message continues to appear and a warning lamp illuminates, have your vehicle checked as soon as possible.*

Catalytic Converter

WHAT IS THE CATALYTIC CONVERTER

The catalytic converter is part of your vehicle's emissions system and filters harmful pollutants from the exhaust gas.

CATALYTIC CONVERTER PRECAUTIONS

 **WARNING:** Do not park, idle or drive your vehicle on dry grass or other dry ground cover. The emission system heats up the engine compartment and exhaust system, creating the risk of fire.

 **WARNING:** The normal operating temperature of the exhaust system is very high. Never work around or attempt to repair any part of the exhaust system until it has cooled. Use special care when working around the catalytic converter. The catalytic converter heats up to a very high temperature after only a short period of engine operation and stays hot after the engine is switched off.

 **WARNING:** Exhaust leaks may result in entry of harmful and potentially lethal fumes into the passenger compartment. If you smell exhaust fumes inside your vehicle, have your vehicle inspected immediately. Do not drive if you smell exhaust fumes.

To avoid damaging the catalytic converter:

- Do not crank the engine for more than 10 seconds at a time.
- Do not run the engine with a spark plug lead disconnected.
- Do not push-start or tow-start your vehicle. Use booster cables. See **Jump Starting the Vehicle** (page 376).
- Use the correct fuel. See **Fuel and Refueling** (page 184).
- Do not switch the ignition off when your vehicle is moving.
- Avoid running out of fuel.
- Have the items listed in scheduled maintenance information performed according to the specified schedule.

Note: Do not make any unauthorized changes to your vehicle or engine. By law, vehicle owners and anyone who manufactures, repairs, or services a fleet of vehicles are not permitted to intentionally remove an emission control device or prevent it from working.

CATALYTIC CONVERTER – TROUBLESHOOTING

CATALYTIC CONVERTER – WARNING LAMPS

Your vehicle has an on-board diagnostics system that monitors the emission control system. If any of the following warning lamps illuminate, this may indicate that the on-board diagnostics system has detected an emission control system malfunction.

Catalytic Converter



Continuing to drive your vehicle may cause reduced power or the engine to stop. Failure to respond to a warning lamp may cause damage that your vehicle Warranty may not cover. Have your vehicle checked as soon as possible.

Automatic Transmission

AUTOMATIC TRANSMISSION POSITIONS

AUTOMATIC TRANSMISSION PRECAUTIONS

WARNING: Apply the parking brake, shift into park (P), switch the vehicle off and remove the key or remote control before you leave your vehicle. Failure to follow this instruction could result in personal injury or death.

WARNING: When your vehicle is stationary, keep the brake pedal fully pressed when shifting gears. Failure to follow this instruction could result in personal injury, death or property damage.

WARNING: Do not apply the brake pedal and accelerator pedal simultaneously. Applying both pedals simultaneously for more than a few seconds limits vehicle performance, which may result in difficulty maintaining speed in traffic and could lead to serious injury.

SHIFTING YOUR VEHICLE INTO GEAR

The selector is on the instrument panel.



1. Press and hold the brake pedal.
2. Rotate the outer ring to select a position.
Note: The position illuminates on the selector.
Note: Your vehicle cannot shift from drive (D) to park (P) with a clockwise rotation. Your vehicle cannot shift from park (P) to drive (D) with a counterclockwise rotation.
3. Press the low (L) or manual (M) or sport (S) button when your vehicle is in drive (D) to enter or exit mode.

PARK (P)

WARNING: Shift into park (P) only when your vehicle is stationary.

In park (P) power is not transmitted to the driven wheels.

Note: A tone sounds if you attempt to exit your vehicle without the vehicle in park (P).

Note: Your vehicle may not shift out of park (P) if the 12 V battery has run out of charge.

Note: Your vehicle may not shift out of park (P) if a fuse is blown.

Note: Your vehicle may not shift out of park (P) unless the key or remote control is inside your vehicle.

Note: The electronic parking brake could apply when you power your vehicle on with the selector in park (P).

Note: The electronic parking brake could apply if you shift to park (P) without fully pressing the brake pedal.

Note: The electronic parking brake could apply if you shift to park (P) on a slope.

Automatic Transmission

Note: Do not manually release the parking brake when the selector is in park (P). See **Automatically Releasing the Electric Parking Brake** (page 217).

Note: Your vehicle could shift into park (P) if you attempt to exit your vehicle without the vehicle in park (P). See **Temporary Neutral Mode** (page 194).

Note: A tone could sound when you select park (P).

REVERSE (R)

 **WARNING:** Shift into reverse (R) only when your vehicle is stationary.

In reverse (R) power is transmitted to the driven wheels.

NEUTRAL (N)

 **WARNING:** In neutral (N) your vehicle is free to roll.

In neutral (N) power is not transmitted to the driven wheels.

DRIVE (D)

In drive (D) power is transmitted to the driven wheels.

Note: Progressive range selection is available in drive (D). See **Using Progressive Range Selection** (page 196).

MANUAL (M)

In manual (M) you can select a specific gear. See **Manually Shifting Gears** (page 193).

Note: We recommend using this mode for driving on hilly or mountainous roads or when towing a trailer. See **Towing a Trailer** (page 335).

AUTOMATIC TRANSMISSION POSITION INDICATORS

The instrument cluster displays the current position.



Note: The position could illuminate on the transmission selector.

MANUALLY SHIFTING GEARS

Shifting Using the Buttons on the Rotary Shifter

The instrument cluster displays the current gear. The current gear flashes when your vehicle cannot shift into the requested gear. Your vehicle does not shift if the requested gear raises or lowers the engine speed beyond the limit.

Your vehicle could shift when you fully press the accelerator or brake pedal.

Note: Prolonged driving with high engine speed could cause vehicle damage not covered by vehicle warranty.

Automatic Transmission

Note: Drive modes could affect when the vehicle shifts into the requested gear.



Manually Shifting Gears in Manual (M)

Use this feature to select a specific gear.

Note: We recommend using this feature for engine braking, driving on hilly or mountainous roads, or when towing a trailer. See **Towing a Trailer** (page 335).

- Shift to manual (M) or with the selector in drive (D) press the manual (M) button to switch the feature on.
- Press the upper (+) button to upshift.
- Press the lower (-) button to downshift.
- Shift to drive (D) or press the manual (M) button again to switch the feature off.

TEMPORARY NEUTRAL MODE

How Does Temporary Neutral Mode Work

Use this mode to keep your vehicle in neutral (N), for a limited time, when you exit your vehicle or switch your vehicle off. For example, if you exit your vehicle before an automatic car wash.

Note: You do not need to use this mode at an automatic car wash if you shift into neutral (N) and stay in your vehicle with power on.

Note: Do not tow your vehicle in this mode.

Note: Automatic return to park (P) is delayed when your vehicle is in this mode. See **Automatic Return to Park (P)** (page 195).

Temporary Neutral Mode Limitations

This mode could be unavailable if your 12 V battery charge level is low. Connect an external power source and attempt the procedure again.

Your vehicle could shift to park (P) after 30 minutes, or when the vehicle battery charge level is low. Prolonged use of this mode can cause the 12 V battery to run out of charge.

This mode could be unavailable if your vehicle is below operating temperature. Warm up your vehicle and attempt the procedure again.

Do not tow your vehicle in this mode. Failure to follow these instructions could result in vehicle damage not covered by the vehicle warranty.

Entering Temporary Neutral Mode

1. Bring your vehicle to a complete stop.
2. Press and hold the brake pedal.
3. Power your vehicle on.
4. Shift into neutral (N).

Note: An instructional message appears.

5. Press the manual (M) button within a few seconds.

Note: A confirmation message appears when your vehicle enters the mode.

6. Release the brake pedal.

Note: Your vehicle is free to roll.

7. Switch your vehicle off.

Note: Do not tow your vehicle in this mode.

Note: The neutral (N) indicator on the transmission selector may flash in this mode.

Automatic Transmission

Exiting Temporary Neutral Mode

1. Press the brake pedal.
2. Shift into park (P), or power your vehicle on and shift into drive (D) or reverse (R).

AUTOMATIC RETURN TO PARK (P)

How Does Automatic Return to Park (P) Work

Your vehicle shifts into park (P) when your vehicle is stationary and any of the following occur:

- You switch the vehicle off.
- You open the driver door with the driver seatbelt unfastened.
- You unfasten the driver seatbelt when the driver door is open.

Note: Do not use automatic return to park (P) when your vehicle is moving, except in an emergency. See **Starting and Stopping the Engine** (page 173).

Automatic Return to Park (P) Limitations

Automatic return to park (P) may not work if any of the following occur:

- The driver door ajar sensor is malfunctioning.
 - The driver seatbelt sensor is malfunctioning.
- See an authorized dealer if any of the following occur:
- Seatbelt indicator illuminates or tone sounds with the driver seatbelt fastened.
 - Door ajar indicator does not illuminate with the driver door open.
 - Door ajar indicator illuminates with the driver door closed.
 - Transmission not in park message appears, with the driver door closed, after you shift out of park (P).

SHIFTING YOUR IMMOBILE VEHICLE OUT OF PARK (P)



WARNING: When doing this procedure, you need to take your vehicle out of park (P) which means your vehicle can roll freely. To avoid unwanted vehicle movement, apply the parking brake prior to doing this procedure. Use wheels chocks if appropriate.

Use this procedure to shift your vehicle out of park (P) in the event of an electrical malfunction or emergency.

Note: This mode could be unavailable if your 12 V battery charge level is low. Connect an external power source and attempt the procedure again.

Note: Your vehicle could shift to park (P) after 30 minutes, or when the vehicle battery charge level is low. Prolonged use of this mode can cause the 12 V battery to run out of charge.

Note: This mode could be unavailable if your vehicle is below operating temperature. Warm up your vehicle and attempt the procedure again.

Note: Do not tow your vehicle in this mode. Failure to follow these instructions could result in vehicle damage not covered by the vehicle warranty.

Shifting Your Vehicle Out of Park (P)

1. Apply the parking brake.

Note: If the battery is out of charge, use an external power source to apply the parking brake.

2. Power your vehicle on without your foot on the brake pedal.
3. Fully press and hold the brake pedal.

Automatic Transmission

4. Fully press and hold the accelerator pedal.
5. Shift into neutral (N).
6. Press the low (L) or manual (M) or sport (S) button within a few seconds.
7. Attempt to start your vehicle.

Note: A confirmation message appears when your vehicle enters the mode.

Note: You must complete this procedure within 15 seconds. If your vehicle shifts into park (P) attempt the procedure again.

8. Release accelerator and brake pedals.
9. Release the parking brake.

Note: Your vehicle is free to roll.

10. Switch your vehicle off.

Note: Do not tow your vehicle in this mode.

Returning Your Vehicle to Normal Mode

1. Press the brake pedal.

2. Shift into park (P).

AUTOMATIC TRANSMISSION AUDIBLE WARNINGS

Transmission Not In Park (P) Audible Warning

Sounds if you open the driver door before shifting into park (P).

USING PROGRESSIVE RANGE SELECTION

Progressive range selection gives you the ability to lock out gears from the automatic shifting range. This could provide you with an improved driving experience by reducing transmission shifts, for example in slippery conditions or steep slopes or when towing a trailer. See **Towing a Trailer** (page 335).

With the transmission in drive (D), press the minus (-) button to begin switching the feature on.

Press the minus (-) button again to continue locking out higher gears. Beginning with the highest gear, the instrument cluster indicates the current gear and highest gear available. For example, press the minus (-) button twice to lock out 10th and 9th gears.

Note: The instrument cluster indicates the current gear and highest gear available.

Press the plus (+) button to unlock gears to allow the transmission to shift to higher gears.

Note: The transmission automatically shifts within the gear range you select.

AUTOMATIC TRANSMISSION FLUID CAPACITY AND SPECIFICATION

Automatic Transmission

Materials

Name	Specification
Motorcraft® MERCON® ULV Automatic Transmission Fluid(U.S.) Motorcraft® MERCON® ULV Automatic Transmission Fluid / MERCON® ULV huile pour boîtes automatique Motorcraft®(Canada) XT-12-QULV(U.S. & Canada)	WSS-M2C949-A,

Note: *Only use transmission fluid that conforms to the defined specification. Use of other fluids could result in vehicle damage not covered by the vehicle warranty.*

Four-Wheel Drive

HOW DOES FOUR-WHEEL DRIVE WORK

Using the 2-Speed Automatic Four-Wheel Drive System

The 2-speed automatic four-wheel drive system utilizes an electronically controlled on-demand 2-speed transfer case. This system monitors various vehicle sensory inputs to provide an increased level of performance. This system offers the driver two-wheel drive high, four-wheel drive auto, four-wheel drive high, and four-wheel drive low as available modes of operation. When you select four-wheel drive auto the system continuously varies power to the front wheels for optimum performance for all on-road conditions. When you select either four-wheel drive high or four-wheel drive low with the appropriate drive modes, the four-wheel drive system provides electronically locked power to the front and rear wheels for use in off-road or slippery conditions such as deep snow, sand or mud. Selecting four-wheel drive low also provides additional gearing for increased torque multiplication for conditions like deep sand, snow, steep slopes, or pulling heavy objects.

See **Selecting a Drive Mode** (page 280). Additionally, the system is capable of recreational flat towing by putting the transfer case into neutral (N). See **Recreationally Towing Your Vehicle** (page 382).

There is further information on driving in unique driving conditions. See **Driving Hints** (page 370).

FOUR-WHEEL DRIVE PRECAUTIONS



WARNING: Vehicles with a higher center of gravity (utility and four-wheel drive vehicles) handle differently than vehicles with a lower center of gravity (passenger cars). Avoid sharp turns, excessive speed and abrupt steering in these vehicles. Failure to drive cautiously increases the risk of losing control of your vehicle, vehicle rollover, personal injury and death.



WARNING: Do not become overconfident in the ability of four-wheel drive vehicles. Although a four-wheel drive vehicle may accelerate better than a two-wheel drive vehicle in low traction situations, it won't stop any faster than two-wheel drive vehicles. Always drive at a safe speed.

Truck and utility vehicles can differ from some other vehicles. Your vehicle could be higher to allow it to travel over rough terrain without getting stuck or damaging underbody components. The differences that make your vehicle so versatile also make it handle differently than an ordinary passenger car. Always maintain steering wheel control, especially in rough terrain. Since sudden changes in terrain can result in abrupt steering wheel motion, make sure you grip the steering wheel from the outside. Do not grip the spokes. Drive cautiously to avoid vehicle damage from concealed objects such as rocks and stumps. Drive slower in strong crosswinds which can affect the normal steering characteristics of your vehicle. Be extremely careful when driving on pavement made slippery by loose sand, water, gravel, snow or ice.

Four-Wheel Drive

Note: Do not use four-wheel drive high or four-wheel drive low mode on dry, hard surfaced roads. Doing so can produce excessive noise, increase tire wear and can damage drive components.

FOUR-WHEEL DRIVE LIMITATIONS

Operating Four-Wheel Drive with a Spare or Mismatched Tires (if Equipped)

On four-wheel drive vehicles, the size of the spare tire can affect the four-wheel drive system. If there is a significant difference between the size of the spare tire and the remaining tires, you could have limited four-wheel drive functionality. When driving with the full-size dissimilar spare wheel and tire assembly, we recommend that you do not:

- Exceed 50 mph (80 km/h) with a four-wheel drive mode turned on.
- Use a four-wheel drive mode on dry pavement.
- Activate a four-wheel drive mode unless the vehicle is stationary.

Driving with the full-size dissimilar spare wheel and tire assembly can limit four-wheel drive functionality. You can experience the following:

- Additional noise from the transfer case or other drive components.
- Difficulty shifting out of a mechanically locked four-wheel drive mode.

Use of a dissimilar spare wheel and tire assembly can lead to impairment of the following:

- Comfort and noise.
- Winter weather driving capability.
- Wet driving capability.
- Four-wheel drive capability.

Note: Your vehicle could have a front air dam that can become damaged, due to reduced ground clearance, when taking your vehicle off-road. You can remove this air dam by removing the eight bolts that secure it.

Note: Your vehicle could have side steps that can become damaged, due to reduced ground clearance, when taking your vehicle off-road. Remove side steps before driving your vehicle off-road.

SELECTING A FOUR-WHEEL DRIVE MODE



The four-wheel drive mode control is located on the left-hand side of the instrument panel.

Four-Wheel Drive

To select a four-wheel drive mode, press the four-wheel drive mode control button of the desired mode. You can select two-wheel drive high (2H), four-wheel drive auto (4A) or four-wheel drive high (4H) at a stop or while driving. Once the shift is complete, the information display shows the selected four-wheel drive mode. While shifts are in progress, the lights on the four-wheel drive control switch flashes until your vehicle achieves the desired shift.

Note: *When shifting to and from four-wheel drive, the information display shows the shifting in progress message indicating that the system is in the process of making a shift.*

Note: *Do not perform this operation if the rear wheels are slipping or while applying the accelerator pedal.*

If the system detects a fault, a warning message appears in the information display. See **Four-Wheel Drive – Information Messages** (page 203).

Shifting to or from Four-Wheel Drive Low (4L)

To select or exit four-wheel drive low (4L):

1. Bring your vehicle to a speed of 3 mph (5 km/h) or less.
2. Place the transmission in neutral (N)

3. Press the desired four-wheel drive button on the four-wheel drive mode control switch.

The information display shows a message indicating a four-wheel drive shift is in progress. If any of the above shift conditions are not present, the shift does not occur and the information display shows information guiding the driver through the proper shifting procedures. If there is a transfer case tooth blockage, a message displays in the information display. To alleviate this condition, place the transmission in a forward gear, move your vehicle forward approximately 5 ft (1.5 m), and shift the transmission back to neutral (N) to allow the transfer case to complete the range shift.

Note: *You could hear some noise as the system shifts or engages which is normal.*

If the system detects a fault, a warning message appears in the information display. See **Four-Wheel Drive – Information Messages** (page 203).

FOUR-WHEEL DRIVE MODES

TWO-WHEEL DRIVE HIGH

Two-wheel drive high is for general on-road driving. Power is sent to the rear wheels only.

Note: *Two-wheel drive high can turn on or off based on Drive Mode selection. See **Selecting a Drive Mode** (page 280).*

FOUR-WHEEL DRIVE AUTO

Four-wheel drive auto provides electronically controlled four-wheel drive power to both the front and rear wheels, as required, for increased traction in varying on-road conditions. The four-wheel drive auto tuning varies based on selected Drive Mode. See **Selecting a Drive Mode** (page 280).

Note: *Four-wheel drive auto can turn on or off automatically based on Drive Mode selection. See **Selecting a Drive Mode** (page 280).*

Four-Wheel Drive

FOUR-WHEEL DRIVE HIGH

Four-wheel drive high provides electronically locked four-wheel drive power to both the front and rear wheels for use in off-road or winter conditions such as deep snow, sand or mud. This mode is not for use on dry pavement.

Note: *Four-wheel drive high can turn on or off automatically based on Drive Mode selection. See **Selecting a Drive Mode** (page 280).*

FOUR-WHEEL DRIVE LOW

Four-wheel drive low provides electronically locked four-wheel drive power to both the front and rear wheels for use on low traction surfaces, but does so with additional gearing for increased torque multiplication. This mode is only for off-road conditions such as deep sand, steep slopes, or pulling heavy objects.

Capacities

Variant	Quantity
Four-wheel drive.	1.4–1.6 qt (1.3–1.5 L)

Note: *Four-wheel drive low can turn on or off automatically based on drive mode selection. See **Selecting a Drive Mode** (page 280).*

FOUR-WHEEL DRIVE INDICATORS

Two-wheel Drive High



Momentarily illuminates when you select two-wheel drive high.

Four-wheel Drive Auto



Continuously illuminates when you select four-wheel drive auto.

Four-wheel Drive High



Continuously illuminates when you select four-wheel drive high.

Four-wheel Drive Low



Continuously illuminates when you select four-wheel drive low.

TRANSFER CASE FLUID CAPACITY AND SPECIFICATION

Use fluid that meets the defined specification and viscosity grade.

If you do not use fluid that meets the defined specification and viscosity grade, it could result in:

- Component damage that your vehicle warranty does not cover.
- Reduced vehicle performance.

Four-Wheel Drive

Materials

Name	Specification
Motorcraft® MERCON® LV Automatic Transmission Fluid(U.S.) Motorcraft® MERCON® LV Automatic Transmission Fluid / Huile pour boîte automatique MERCON® LV Motorcraft®(Canada) XT-10-QLVC(U.S.) CXT-10-LV6(Canada)	WSS-M2C938-A

FOUR-WHEEL DRIVE – TROUBLESHOOTING

FOUR-WHEEL DRIVE – WARNING LAMPS



Illuminates when a four-wheel drive or power train fault is present.

Note: *When a system fault is present, the system can typically remain in whichever mode was selected prior to the fault condition occurring. It does not default to two-wheel drive in all circumstances. When this warning displays, have your vehicle serviced by an authorized dealer.*

Four-Wheel Drive

FOUR-WHEEL DRIVE – INFORMATION MESSAGES

Message	Action
Check 4x4	A four-wheel drive system fault is present. Have your vehicle checked as soon as possible.
4x4 Shift in Progress	The four-wheel drive system is making a shift.
For 4x4 LOW Shift to N	Displays when you attempt to switch to four-wheel drive low mode and you do not shift the transmission to neutral (N) first.
For 4x4 LOW Slow to 3 MPH	Displays when you attempt to switch to four-wheel drive low mode and your vehicle's speed is greater than 3 mph (5 km/h).
For 4x4 LOW Slow to 5 km/h	
To Exit 4x4 LOW Shift to N	Displays when you attempt to switch from four-wheel drive low mode and you do not shift the transmission to neutral (N) first.
To Exit 4x4 LOW Slow to 3 MPH	Displays when you attempt to switch from four-wheel drive low mode and your vehicle's speed is greater than 3 mph (5 km/h).
To Exit 4x4 LOW Slow to 5 km/h	
Shift Delayed Drive Forward	Displays when there is a transfer case gear tooth blockage while shifting to or from four-wheel drive low mode or to the neutral (N) state. Place the transmission in a forward gear, move your vehicle forward approximately 5 ft (1.5 m), and shift the transmission back to neutral (N) to allow the transfer case to complete the range shift.
4x4 Temporarily Disabled	Displays when the four-wheel system detects elevated system temperature and temporarily stops providing power to the front wheels. The system automatically resumes normal function when the system temperature returns to normal.

Four-Wheel Drive

Message	Action
4x4 Restored	Displays when the four-wheel drive system resumes normal function.
4X4 Temporarily Locked	Displays when the four-wheel drive system detects driving conditions which temporarily require greater four-wheel drive performance. The system automatically resumes normal function after the system no longer detects these driving conditions.
Shift to Neutral	Displays when the system requires an additional transmission shift to neutral (N) to complete a transfer case shift.

Front Axle

FRONT AXLE FLUID CAPACITY AND SPECIFICATION

Use fluid that meets the defined specification and viscosity grade.

If you do not use fluid that meets the defined specification and viscosity grade, it could result in:

- Component damage that your vehicle warranty does not cover.
- Reduced vehicle performance.

Capacities

Variant	Quantity
Four-wheel drive.	1.8 qt (1.7 L)

Materials

Name	Specification
Motorcraft® SAE 75W-85 Premium Synthetic Hypoid Gear Lubricant (U.S.) Motorcraft® SAE 75W-85 Premium Synthetic Hypoid Gear Lubricant / Huile synthétique de haute qualité pour engrenages hypoides SAE 75W-85 Motorcraft® (Canada) XY-75W85-QL (U.S. & Canada)	WSS-M2C942-A

Rear Axle

REAR AXLE FLUID CAPACITY AND SPECIFICATION

Use fluid that meets the defined specification and viscosity grade.

If you do not use fluid that meets the defined specification and viscosity grade, it could result in:

- Component damage that your vehicle warranty does not cover.
- Reduced vehicle performance.

Rear Axle - 8.8

Capacities

Variant	Quantity
All.	1.8–2.0 qt (1.66–1.89 L)

Materials

Name	Specification
Motorcraft® SAE 75W-85 Premium Synthetic Hypoid Gear Lubricant(U.S.) Motorcraft® SAE 75W-85 Premium Synthetic Hypoid Gear Lubricant / Huile synthétique de haute qualité pour engrenages hypoides SAE 75W-85 Motorcraft®(Canada) XY-75W85-QL(U.S. & Canada)	WSS-M2C942-A

Rear Axle

Rear Axle - 9.75 with open differential

Capacities

Variant	Quantity
All.	2.00–2.25 qt (1.89–2.13 L)

Materials

Name	Specification
Motorcraft® SAE 75W-85 Premium Synthetic Hypoid Gear Lubricant (U.S.) Motorcraft® SAE 75W-85 Premium Synthetic Hypoid Gear Lubricant / Huile synthétique de haute qualité pour engrenages hypoides SAE 75W-85 Motorcraft® (Canada) XY-75W85-QL (U.S. & Canada)	WSS-M2C942-A

Rear Axle - 9.75 with electric locking differential

Capacities

Variant	Quantity
All.	2.00–2.25 qt (1.89–2.13 L)

Rear Axle

Materials

Name	Specification
Motorcraft® SAE 75W-85 Premium Synthetic Hypoid Gear Lubricant(U.S.) Motorcraft® SAE 75W-85 Premium Synthetic Hypoid Gear Lubricant / Huile synthétique de haute qualité pour engrenages hypoides SAE 75W-85 Motorcraft®(Canada) XY-75W85-QL(U.S. & Canada)	WSS-M2C942-A

Electronic Locking Differential (If Equipped)

WHAT IS THE ELECTRONIC LOCKING DIFFERENTIAL

The electronic locking differential is a device housed in the rear axle, and can provide additional traction when needed.

HOW DOES THE ELECTRONIC LOCKING DIFFERENTIAL WORK

You can activate the differential electronically and shift it on the fly within the operating speed range. The electronic differential disengages when the vehicle speed exceeds a set value, and reengages when the vehicle speed goes below a set value. See **Switching the Electronic Locking Differential On and Off** (page 209). It also engages based on certain selected drive modes. See **Selecting a Drive Mode** (page 280). The electronic locking differential is for use in mud, rocks, sand, or any off-road condition where you need maximum traction.

Note: *The electronic locking differential can activate or deactivate automatically based on speed, four-wheel drive mode, and drive mode selection. See **Switching the Electronic Locking Differential On and Off** (page 209).*

Note: *The electronic locking differential is for off-road use only and is not for use on dry pavement. Using the electronic locking differential on dry pavement results in increased tire wear, noise and vibration.*

Note: *Do not perform this operation when cruise control or trail control are selected and active. The system may not engage as expected.*

ELECTRONIC LOCKING DIFFERENTIAL PRECAUTIONS

Operating the Electronic Locking Differential with a Spare or Mismatched Tires

On vehicles with an electronic locking differential, the size of the spare tire can affect performance of the system. If there is a significant difference between the two rear tires, you may have limited electronic locking differential functionality. If the system has difficulty disengaging, release the accelerator pedal and turn the steering wheel in the opposite direction when rolling. We recommend engaging and disengaging the electronic locking differential at a stop when you mount a spare on the rear axle.

SWITCHING THE ELECTRONIC LOCKING DIFFERENTIAL ON AND OFF

The button to activate and deactivate the electronic locking differential is in the center of the drive mode control.

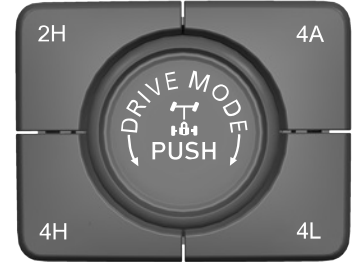

To manually activate or deactivate the electronic locking differential, press the electronic locking differential button.

Note: *The electronic locking differential can automatically activate or deactivate based on speed, four-wheel drive mode, and drive mode selection. See **Selecting a Drive Mode** (page 280).*

Electronic Locking Differential (If Equipped)

4X4 Rear Electronic Locking Differential Engagement Speed and Availability

Drive Modes	Maximum Engagement Speed	Automatic Disengagement Speed	Automatic Re-Engagement Speed
Normal (2H, 4A, 4H)	20 mph (30 km/h)	25 mph (41 km/h)	20 mph (30 km/h)
Eco (2H, 4A, 4H)	20 mph (30 km/h)	25 mph (41 km/h)	20 mph (30 km/h)
Sport (2H, 4A, 4H)	20 mph (30 km/h)	25 mph (41 km/h)	20 mph (30 km/h)
Slippery (4A, 4H)	20 mph (30 km/h)	25 mph (41 km/h)	20 mph (30 km/h)
Off Road (4H, 4L) ¹	No Speed Limit	No Speed Limit	No Speed Limit
Rock Crawl (4L) ¹	No Speed Limit	No Speed Limit	No Speed Limit
Tow/Haul Mode	20 mph (30 km/h)	25 mph (41 km/h)	20 mph (30 km/h)

¹Automatically engages when you select these drive modes. You have the ability to manually override the automatic engagement by pressing the electronic locking differential button.

4WD Mode	Maximum Engagement Speed	Automatic Disengagement Speed	Automatic Re-Engagement Speed
Four-Wheel Drive Low (4L)	No speed Limit	No speed Limit	No speed Limit

Note: The electronic locking differential may not engage if you press the accelerator pedal during an engagement attempt. A message could display in the instrument cluster display instructing you to release the accelerator pedal.

Note: If the electronic locking differential has difficulty disengaging, release the accelerator pedal and turn the steering wheel in the opposite direction while the vehicle is moving.

Note: The electronic locking differential is for off-road use only and is not for use on dry pavement. Using the electronic locking differential on dry pavement results in increased tire wear, noise and vibration.

Electronic Locking Differential (If Equipped)

Note: Do not perform this operation when cruise control or trail control are selected and active. The system may not engage as expected.

ELECTRONIC LOCKING DIFFERENTIAL INDICATORS



If both rear wheel axle shafts lock together, the instrument cluster indicator is amber, providing additional traction.

If you select the electronic locking differential and the instrument cluster indicator is gray or turns from amber to gray while driving, one of the following has occurred:

- The vehicle speed is too high.
- The accelerator pedal is too high during an engagement attempt.
- The vehicle is experiencing an anti-lock brake activation.

- The left and right wheel speed difference is too high during an engagement attempt.
- The system has malfunctioned and accompanies a check locking differential message in the instrument cluster display. See your dealer as soon as possible.
- The system battery voltage is too low and may require the engine to be running.

Note: If the vehicle is experiencing an anti-lock braking event, the electronic locking differential could momentarily disengage.

ELECTRONIC LOCKING DIFFERENTIAL – TROUBLESHOOTING

ELECTRONIC LOCKING DIFFERENTIAL – INFORMATION MESSAGES

Message	Details
To Engage Locking Differential Slow to 20 mph (30 km/h)	The electronic locking differential has been requested and will engage when the speed condition is met.
To Engage Locking Differential Release Accelerator Pedal	Release the accelerator pedal in order to engage.
Check Locking Differential	An electronic locking differential system fault is present. Contact an authorized dealer as soon as possible.

Brakes

BRAKE PRECAUTIONS

Wet brakes result in reduced braking efficiency. Gently press the brake pedal a few times when leaving a car wash or driving from standing water to dry the brakes.

Note: *Depending on applicable laws and regulations in the country for which your vehicle was originally built, your brake lamps may flash during heavy braking. Following this, your hazard lights may also flash when your vehicle comes to a stop.*

ANTI-LOCK BRAKING SYSTEM

ANTI-LOCK BRAKING SYSTEM LIMITATIONS

The anti-lock braking system does not eliminate the risk of crash when:

- You drive too closely to the vehicle in front of you.
- Your vehicle is hydroplaning.
- You take corners too fast.
- The road surface is poor.

Note: *If the system activates, the brake pedal could pulse and travel further. Maintain pressure on the brake pedal.*

BRAKE OVER ACCELERATOR

In the event the accelerator pedal becomes stuck or entrapped, apply steady and firm pressure to the brake pedal to slow the vehicle and reduce engine power. If you experience this condition, apply the brakes and bring your vehicle to a safe stop. Move the transmission to park (P), switch the engine off and apply the parking brake. Inspect the accelerator pedal for any interference. If none are found and the condition persists, have your vehicle towed to the nearest authorized dealer.

LOCATING THE BRAKE FLUID RESERVOIR

See **Under Hood Overview** (page 397).

CHECKING THE BRAKE FLUID

 **WARNING:** Do not use any fluid other than the recommended brake fluid as this will reduce brake efficiency. Use of incorrect fluid could result in the loss of vehicle control, serious personal injury or death.

 **WARNING:** Only use brake fluid from a sealed container. Contamination with dirt, water, petroleum products or other materials may result in brake system damage or failure. Failure to adhere to this warning could result in the loss of vehicle control, serious personal injury or death.

 **WARNING:** Do not allow the fluid to touch your skin or eyes. If this happens, rinse the affected areas immediately with plenty of water and contact your physician.

 **WARNING:** The brake system could be affected if the brake fluid level is below the **MIN** mark or above the **MAX** mark on the brake fluid reservoir.

1. Park your vehicle on a level surface.

Brakes



2. Look at the brake fluid reservoir to see where the brake fluid level is relative to the **MIN** and the **MAX** marks on the reservoir.

Note: To avoid fluid contamination, the reservoir cap must remain in place and fully tight, unless you are adding fluid.

Only use fluid that meets our specifications. See **Brake Fluid Specification** (page 213).

BRAKE FLUID SPECIFICATION

Use fluid that meets the defined specification and viscosity grade.

If you do not use fluid that meets the defined specification and viscosity grade, it could result in:

- Component damage that your vehicle warranty does not cover.
- Reduced brake performance.

Note: We recommend you to use Dot 4 Low Viscosity (LV) High Performance Brake Fluid meeting WSS-M6C65-A2 specifications or ISO 4925 Class 6 standards. If you use any fluid other than the recommended fluid, it could cause reduced brake performance and not meet our performance standards. Keep brake fluid clean and dry. Contamination with dirt, water, petroleum products or other materials could result in brake system damage and possible failure.

Capacities

Variant	Quantity
All.	Fill as required.

Brakes

Materials

Name	Specification
Motorcraft® DOT 4 LV High Performance Motor Vehicle Brake Fluid (U.S.) Motorcraft® DOT 4 LV High Performance Motor Vehicle Brake Fluid / Liquide de frein automobile haute performance DOT 4 LV Motorcraft® (Canada) PM-20 (U.S. & Canada)	WSS-M6C65-A2

BRAKES – TROUBLESHOOTING

BRAKES – WARNING LAMPS



WARNING: Driving your vehicle with the warning lamp on is dangerous. A significant decrease in braking performance may occur. It may take you longer to stop your vehicle. Have your vehicle checked as soon as possible. Driving extended distances with the parking brake engaged can cause brake failure and the risk of personal injury.



If the ABS indicator illuminates when you are driving, this indicates a malfunction. Your vehicle continues to have normal braking without the anti-lock braking system function. See an authorized dealer.

It also momentarily illuminates when you switch the ignition on to confirm the lamp is functional. If it does not illuminate when you switch the ignition on, or begins to flash at any time, have the system checked by an authorized dealer.



The brake indicator momentarily illuminates when you switch the ignition on to confirm the lamp is functional. It may also illuminate when you apply the parking brake and the ignition is on. If it illuminates when your vehicle is moving, make sure the parking brake is disengaged. If the parking brake is disengaged, this indicates low brake fluid level or a brake system fault. See an authorized dealer.

Note: *Lamps may vary depending on region.*

Brakes

BRAKES – FREQUENTLY ASKED QUESTIONS

Is it normal for my brakes to make noise?

Occasional brake noise is normal. If a metal-to-metal, continuous grinding, or squeal sound is present, the brake lining could be worn. Have the system checked.

There is an electrical motor sound when I press on the brake pedal or activate the park brake switch. Is this normal?

Yes, those sounds are the electronic brake booster or the electronic park brake operating.

Note: *Brake dust could accumulate on the wheels, even under normal driving conditions. Some dust is normal as the brakes wear and does not contribute to brake noise. See **Cleaning Wheels** (page 418).*

Electric Parking Brake

WHAT IS THE ELECTRIC PARKING BRAKE

The electric parking brake is used to hold your vehicle on slopes and flat roads.

APPLYING THE ELECTRIC PARKING BRAKE

 **WARNING:** Apply the parking brake, shift into park (P), switch the ignition off and remove the key before you leave your vehicle. Failure to follow this instruction could result in personal injury or death.

 **WARNING:** If you drive extended distances with the parking brake applied, you could cause damage to the brake system.

 **WARNING:** The electric parking brake does not operate if the vehicle battery has run out of charge.

 **WARNING:** If the parking brake is fully released, but the brake warning lamp remains illuminated, the brakes may not be working properly. Have your vehicle checked as soon as possible.



The switch is on the lower part of the instrument panel.

Pull the switch up to apply the electric parking brake. The red warning lamp flashes, then steadily illuminates when the parking brake is applied.

Note: You can apply the electric parking brake when the ignition is off.

Note: The electric parking brake could automatically apply when park (P) is selected. See **Park (P)** (page 192).

APPLYING THE ELECTRIC PARKING BRAKE IN AN EMERGENCY

You can use the electric parking brake to slow or stop your vehicle in an emergency.

Pull the switch up and hold it.

The red warning lamp illuminates, a tone sounds and the stoplamps turn on when you use the electric parking brake in an emergency.

The electric parking brake continues to slow your vehicle down unless you release the switch.

Note: Do not apply the electric parking brake when your vehicle is moving, except in an emergency. If you repeatedly use the electric parking brake to slow or stop your vehicle, you could cause damage to the brake system.

MANUALLY RELEASING THE ELECTRIC PARKING BRAKE

1. Switch the ignition on.
2. Press and hold the brake pedal.
3. Push the switch down.

The red warning lamp turns off.

Pulling Away When Towing a Trailer Uphill

1. Press and hold the brake pedal.
2. Pull the switch upward and hold it.
3. Shift into gear.

Electric Parking Brake

4. Press the accelerator pedal until engine has developed sufficient torque to prevent your vehicle from rolling down the hill.
5. Release the switch and pull away in a normal manner.

AUTOMATICALLY RELEASING THE ELECTRIC PARKING BRAKE

1. Close the driver door.
2. Shift into gear.
3. Press the accelerator pedal and pull away in a normal manner.

ELECTRIC PARKING BRAKE AUDIBLE WARNING

Sounds when the parking brake is on and your vehicle is moving. If the warning tone continues after you have released the parking brake, this indicates a malfunction. Have your vehicle checked as soon as possible.

RELEASING THE ELECTRIC PARKING BRAKE IF THE VEHICLE BATTERY HAS RUN OUT OF CHARGE

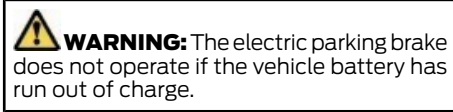

Connect a booster battery to the vehicle battery to release the electric parking brake if the vehicle battery has run out of charge. See **Jump Starting the Vehicle** (page 376).

ELECTRIC PARKING BRAKE – TROUBLESHOOTING

ELECTRIC PARKING BRAKE – WARNING LAMPS

Brake System

BRAKE Lamp illuminates red when you apply the parking brake and your vehicle is on. If the lamp flashes when the parking brake has been released, this indicates the parking brake system requires service.

Have your vehicle checked as soon as possible.

Note: Lamps may vary depending on region.

Electric Parking Brake



⚡ When the lamp illuminates yellow, it indicates a malfunction in the electric parking brake. Have your vehicle checked as soon as possible.

Note: Lamps may vary depending on region.

Electric Parking Brake

ELECTRIC PARKING BRAKE – INFORMATION MESSAGES

Message	Action
To Release: Press Brake and Switch	The electric parking brake is set and a manual release is attempted without the brake pedal being pressed.
Park Brake Use Switch to Release	The electric parking brake is set and an automatic release is attempted but cannot be performed. Perform a manual release.
Release Park Brake	The electric parking brake is set and your vehicle speed exceeds 3 mph (5 km/h). Release the electric parking brake before continuing to drive.
Park Brake Not Applied	The electric parking brake is not fully applied.
Park Brake Not Released	The electric parking brake is not fully released.
Brake maintenance mode	The electric parking brake system has been put into a special mode to allow brake service. Have the system checked as soon as possible.
Park Brake Limited Function Service Required	The electric parking brake system has detected a condition that requires service. Some functionality may still be available. Have the system checked as soon as possible.
Park Brake Malfunction Service Now	The electric parking brake system has detected a condition that requires service. Have the system checked as soon as possible.

Reverse Brake Assist

WHAT IS REVERSE BRAKE ASSIST

Reverse brake assist is designed to reduce impact damage or assist in avoiding a collision while in reverse (R).

HOW DOES REVERSE BRAKE ASSIST WORK

Reverse brake assist functions when in reverse (R) and traveling at a speed of 1–7 mph (2–12 km/h).

If the system detects an obstacle behind your vehicle, it provides a warning through the rear parking aid or cross traffic alert system.

REVERSE BRAKE ASSIST PRECAUTIONS

 **WARNING:** You are responsible for controlling your vehicle at all times. The system is designed to be an aid and does not relieve you of your responsibility to drive with due care and attention. Failure to follow this instruction could result in the loss of control of your vehicle, personal injury or death.

 **WARNING:** To help avoid personal injury, always use caution when in reverse (R) and when using the sensing system.

 **WARNING:** The system may not operate properly during severe weather conditions, for example snow, ice, heavy rain and spray. Always drive with due care and attention. Failure to take care may result in a crash.

 **WARNING:** Traffic control systems, fluorescent lamps, inclement weather, air brakes, external motors and fans may affect the correct operation of the sensing system. This may cause reduced performance or false alerts.

 **WARNING:** Some situations and objects prevent hazard detection. For example low or direct sunlight, inclement weather, unconventional vehicle types, and pedestrians. Apply the brakes when necessary. Failure to follow this instruction could result in the loss of control of your vehicle, personal injury or death.

 **WARNING:** Do not use the system with accessories that extend beyond the front or rear of your vehicle, for example a trailer hitch or bike rack. The system is not able to make corrections for the additional length of the accessories.

The system only applies the brakes for a short period of time when an event occurs. Act as soon as you notice the brakes apply to remain in control of the vehicle. If you do not intervene the vehicle may start to move again.

Note: *Certain add-on devices around the bumper or fascia may create false alerts. For example, large trailer hitches, bicycle or surfboard racks, license plate brackets, bumper covers or any other device that may block the normal detection zone of the system. Remove the add-on device to prevent false alerts.*

Reverse Brake Assist

Note: The system does not react to small or moving objects, particularly those close to the ground.

Note: The system does not operate during hard acceleration or steering.

Note: If your vehicle sustains damage to the bumper or fascia leaving it misaligned or bent, it could alter the sensing zone causing inaccurate measurement of obstacles or false alerts.

Note: Vehicle loading and suspension changes can impact the angle of the sensors and may change the normal detection zone of the system resulting in inaccurate measurement of obstacles or false alerts.

Note: When you connect a trailer, the system may detect the trailer and provide an alert, or the system turns off. If the system does not turn off, manually switch the system off after you connect the trailer.

Note: You may experience reduced system performance on road surfaces that limit deceleration. For example, roads with ice, loose gravel, mud or sand.

SWITCHING REVERSE BRAKE ASSIST ON AND OFF

1. From the settings menu, press Driver Assistance.
2. Switch Reverse Brake Assist on or off.

Note: The system is unavailable when rear parking aid or cross traffic alert is off.

The default setting is on in some regions.

OVERRIDING REVERSE BRAKE ASSIST

There could be instances when unexpected or unwanted braking occurs. Firmly pressing the accelerator pedal or switching the feature off overrides the system.

REVERSE BRAKE ASSIST INDICATORS

If the system determines that a collision with an obstacle may occur, full braking may apply.



A message and warning indicator appear when the system applies the brakes.

Reverse Brake Assist

REVERSE BRAKE ASSIST – TROUBLESHOOTING

REVERSE BRAKE ASSIST – INFORMATION MESSAGES

Message	Description
Reverse Brake Assist	Displays for a few seconds when the system applies the brakes.
Reverse Brake Assist Not Available See Manual	Displays when a related system or feature error occurs. Make sure the exterior cameras are clean and not obstructed. Drive the vehicle on a straight road for a short period. If the message remains, have the system checked as soon as possible.
Reverse Brake Assist Fault	Displays when a system error has occurred. Have your vehicle checked as soon as possible.
Reverse Brake Assist Off	Displays when reverse brake assist is off.

Reverse Brake Assist

REVERSE BRAKE ASSIST – FREQUENTLY ASKED QUESTIONS

Why is reverse brake assist unavailable?

- Make sure you switch the system on. See **Switching Reverse Brake Assist On and Off** (page 220).
- Make sure that the liftgate or tailgate, hood and all doors are closed.
- Make sure the cross traffic alert system is on. See **What Is Cross Traffic Alert** (page 304).
- Make sure the rear parking aid system is on. See **What is the Rear Parking Aid** (page 244).
- Make sure that traction control is on. See **Switching Traction Control On and Off** (page 225).
- Your vehicle may have sustained a rear end impact. Have the sensors checked for proper coverage and operation.

- Make sure the exterior cameras are not dirty or obstructed. If dirty, clean the cameras. If the reverse brake assist unavailable message still appears after cleaning the cameras, wait a short time for the message to clear. If the message does not clear, drive the vehicle on a straight road for a short period. If the message remains, have the system checked.
- Make sure the sensors are not blocked or faulted. See **Locating the Rear Parking Aid Sensors** (page 244). See **Locating the Cross Traffic Alert Sensors** (page 306).
- You recently had your vehicle serviced, or the battery disconnected. Drive your vehicle a short distance to resume system operation.
- The system does not function when you connect a trailer. Operation resumes when you disconnect the trailer.

Note: *If you are still having problems with reverse brake assist, have the system checked as soon as possible.*

Hill Start Assist

WHAT IS HILL START ASSIST

Hill Start Assist applies the brakes to hold your vehicle after you bring it to a stop on a slope. This makes it easier for you to pull away without using the parking brake.

HOW DOES HILL START ASSIST WORK

When the system activates, your vehicle remains stationary for a few seconds after you release the brake pedal. This gives you time to move your foot from the brake pedal to the accelerator pedal. The brakes release when you apply the accelerator pedal and the vehicle begins to move forward, or the system exceeds the time allowed for automatically applying the brakes.

The system activates when your vehicle is in any forward gear and facing uphill, or when your vehicle is in reverse (R) and facing downhill.

HILL START ASSIST PRECAUTIONS



WARNING: The system does not replace the parking brake. When you leave your vehicle, always apply the parking brake.



WARNING: You must remain in your vehicle when the system turns on. At all times you are responsible for controlling your vehicle, supervising the system, and intervening if required. Failure to follow this instruction could result in the loss of control of your vehicle, personal injury or death.



WARNING: The system turns off if there is a malfunction.

HILL START ASSIST – TROUBLESHOOTING

HILL START ASSIST – INFORMATION MESSAGES

Message	Details
Hill Start Assist Not Available	Displays when system is not available. Have your vehicle checked as soon as possible.

Auto Hold

HOW DOES AUTO HOLD WORK

Auto hold applies the brakes to hold your vehicle after you bring the vehicle to a stop. This can help when waiting on a hill or in traffic.

SWITCHING AUTO HOLD ON AND OFF



WARNING: The system does not replace the parking brake. When you leave your vehicle, always apply the parking brake.



WARNING: You must remain in your vehicle when the system turns on. At all times you are responsible for controlling your vehicle, supervising the system, and intervening if required. Failure to follow this instruction could result in the loss of control of your vehicle, personal injury or death.



WARNING: The system will turn off if a malfunction is apparent. Failure to take care may result in the loss of control of your vehicle, serious personal injury or death.

1. From the controls menu, switch Auto hold on or off.

Note: You can only switch the system on after you close the driver door and start the engine.

Note: The system remembers the last setting when you start your vehicle.

Make sure you switch the system off before towing with your vehicle or before using an automatic car wash.

USING AUTO HOLD

1. Bring your vehicle to a complete stop. The auto hold active indicator illuminates in the instrument cluster display.
2. Release the brake pedal. The system holds your vehicle at a standstill. The auto hold active indicator remains illuminated in the instrument cluster display.
3. Apply the accelerator and drive off in a normal manner. The system releases the brakes and the auto hold active indicator switches off.

Note: The system only activates if you apply enough pressure to the brake pedal to bring the vehicle to a standstill.

Note: Under certain conditions, the system could apply the electric parking brake. The brake system warning lamp illuminates. The electric parking brake releases when you press the accelerator pedal. See **Automatically Releasing the Electric Parking Brake** (page 217).

Note: The system switches off if you shift into reverse (R) or neutral (N) while pressing the brake pedal.

There could be actions that can cause the auto hold system not to work when the following occur:

- Your vehicle is in temporary neutral mode.
- The driver door is open.
- You shift into reverse (R) or neutral (N) before the system is active.

AUTO HOLD INDICATORS



Illuminates when the system is active.



Illuminates when the system is on but cannot hold your vehicle at a standstill at this particular time.

Traction Control

WHAT IS TRACTION CONTROL

The traction control system helps to avoid drive wheel spin and loss of traction.

HOW DOES TRACTION CONTROL WORK

If your wheels begin to spin, the loss of traction can compromise steering control and stability of the vehicle. The traction control system applies the brakes to individual wheels and when needed, reduces engine power at the same time to increase traction.

SWITCHING TRACTION CONTROL ON AND OFF



WARNING: Operating your vehicle with the traction control disabled could lead to an increased risk of loss of vehicle control, vehicle rollover, personal injury and death.



The traction control system turns on each time you switch the ignition on.

The button for the stability and traction control system is on the instrument panel.

Press and release the button to switch traction control off. The stability control system remains fully active, to switch it off, press and hold the button for a few seconds, then release.

When you switch traction control off, a message and an illuminated icon appear on the instrument cluster.

Press the switch again to turn the traction control system back on to normal operation.

If your vehicle is stuck in mud or snow, switching traction control off may be beneficial as this allows the wheels to spin.

TRACTION CONTROL INDICATOR

Stability and Traction Control Indicator



If the indicator does not illuminate when you switch the ignition on, or remains on when the engine is running, this indicates a malfunction. Have your vehicle checked by an authorized dealer as soon as possible.



The traction control off indicator illuminates when you switch the traction control system off, or when an alternative stability control mode is selected that requires the traction control off depending on the drive mode selected.

Traction Control

TRACTION CONTROL – TROUBLESHOOTING

TRACTION CONTROL – WARNING LAMPS

System Messages

TRACTION CONTROL – INFORMATION MESSAGES



The traction control light temporarily illuminates on start-up and flashes when activated by a driving condition. The light stays on if a problem occurs in the system.



The traction control off light temporarily illuminates on start-up and stays on:

- When you switch the traction control system off.
- When you select an alternative stability control mode.

Message	Action
Service AdvanceTrac	The system detects a condition that requires service. Contact an authorized dealer as soon as possible.
AdvanceTrac Off	The status of the AdvanceTrac system after you switched it off.
AdvanceTrac On	The status of the AdvanceTrac system after you switched it on.
Traction Control Off	The status of the traction control system after you switched it off.
Traction Control On	The status of the traction control system after you switched it on.

Stability Control

HOW DOES STABILITY CONTROL WORK



WARNING: Vehicle modifications involving braking system, aftermarket roof racks, suspension, steering system, tire construction and wheel and tire size may change the handling characteristics of your vehicle and may adversely affect the performance of the electronic stability control system. In addition, installing any stereo speakers may interfere with and adversely affect the electronic stability control system. Reducing the effectiveness of the electronic stability control system could lead to an increased risk of loss of vehicle control, vehicle rollover, personal injury and death.



WARNING: Remember that even advanced technology cannot defy the laws of physics. It's always possible to lose control of a vehicle due to inappropriate driver input for the conditions. Aggressive driving on any road condition can cause you to lose control of your vehicle increasing the risk of personal injury or property damage. Activation of the electronic stability control system is an indication that

at least some of the tires have exceeded their ability to grip the road; this could reduce the operator's ability to control the vehicle potentially resulting in a loss of vehicle control, vehicle rollover, personal injury and death.



WARNING: You are responsible for controlling your vehicle at all times. The system is designed to be an aid and does not relieve you of your responsibility to drive with due care and attention. Failure to follow this instruction could result in the loss of control of your vehicle, personal injury or death.

If a driving condition activates either the stability control or traction control you may experience the following conditions:

- The stability and traction control light flashes.
- Your vehicle slows down.
- Reduced engine power.

The stability control system has several features built into it to help you maintain control of your vehicle:

Electronic Stability Control

Electronic stability control enhances your vehicle's ability to prevent skids or lateral slides by applying brakes to one or more of the wheels individually and, if necessary, reducing engine power.

Roll Stability Control

Roll stability control enhances your vehicle's ability to prevent rollovers by detecting your vehicle's roll motion and the rate at which it changes by applying the brakes to one or more wheels individually.

Curve Control

Curve control enhances your vehicle's ability to follow the road when cornering severely or avoiding objects in the roadway. Curve control operates by reducing engine power and, if necessary, applying brakes to one or more of the wheels individually.

Side Wind Stabilization

Side wind stabilization is an advanced feature that works by carefully applying the brakes on one side of the vehicle to reduce the effect of a side wind gust on the vehicle's path.

Stability Control

Traction Control

Traction control enhances your vehicle's ability to maintain traction of the wheels by detecting and controlling wheel spin. See **Traction Control** (page 225).

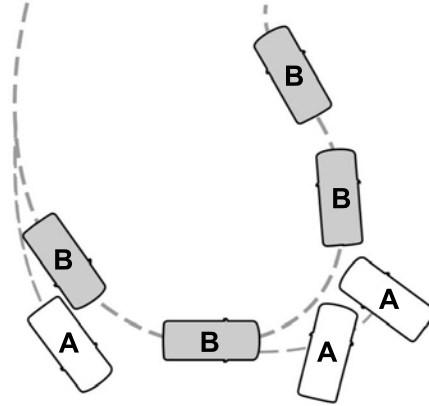

- A Vehicle without stability control skidding off its intended route.
- B Vehicle with stability control maintaining control on a slippery surface.

SWITCHING STABILITY CONTROL ON AND OFF

The system turns on each time you switch the ignition on.

You can switch the electronic stability control system off by pressing and holding the ESC off button for over 5 seconds, or you can press the button again to switch the system on.

Shifting the transmission into reverse (R) will disable the system.

You can switch the traction control system off or on independently. See **Switching Traction Control On and Off** (page 225).

Stability Control

Stability Control and Traction Control with Roll Stability Control

	Stability Control OFF Light	Roll Stability Control³	Electronic Stability Control³	Traction Control System³
Default at start-up	Illuminated during bulb check	Enabled	Enabled ³	Enabled
Button pressed momentarily	illuminated	Enabled	Enabled ³	Disabled ¹
Button Pressed and held for 5 - 15 seconds	illuminated	Enabled	Disabled ²	Disabled ¹
Button not pressed and transfer case is switched to 4x4 Low or put into Rock Crawl Mode	illuminated	Disabled	Disabled	Disabled ¹

¹ The Traction Control system can still be enabled but with tighter or looser thresholds.

² When you press and hold the button, a progress bar will display to show the button hold time progress.

³ Functions can vary depending on what selectable drive mode the vehicle is currently in.

Stability Control

STABILITY CONTROL INDICATOR



If it does not illuminate when you switch the power on, or remains on, this indicates a malfunction. Have your vehicle checked by an authorized dealer as soon as possible.

Trail Control (If Equipped)

WHAT IS TRAIL CONTROL



WARNING: The system does not control speed in low traction conditions or extremely steep slopes. The system is designed to be an aid and does not relieve you of your responsibility to drive with due care and attention. Failure to follow this instruction could result in personal injury.



WARNING: The system does not replace the parking brake. When you leave your vehicle, always apply the parking brake.

Trail control lets you focus on steering during low-speed and off-road use by controlling your vehicle's acceleration and braking to maintain the speed that you set.

You may hear a noise from the anti-lock brake system pump motor when you use the system. This is normal.

SWITCHING TRAIL CONTROL ON AND OFF



Press the trail features button on the instrument panel. Once switched on, use the SET + or SET - button to activate trail control.

The system switches off if you press the button again or exceed 40 mph (64 km/h).

Note: Trail one pedal drive initially engages when the trail features button is pressed. Trail control activates when the SET +/- button is pressed.

SETTING THE TRAIL CONTROL SPEED

Note: The buttons are on the steering wheel.

Drive to the speed you prefer.



Press the button to set or increase the set speed. Press and hold to adjust the speed in larger increments.



Press the button to set or decrease the set speed. Press and hold to adjust the speed in larger increments.

Note: The indicator changes color.

You can also adjust the set speed by braking, then pressing the + or - button.

Note: Pressing the brake pedal does not switch off the system.

CANCELING THE SET SPEED



Press the button.

TRAIL CONTROL INDICATORS



When trail control is active, the indicator illuminates green in the instrument cluster. When the system is switched on but is unavailable or in standby mode, it illuminates gray.

Trail Control (If Equipped)

TRAIL ONE PEDAL DRIVE

WHAT IS TRAIL ONE PEDAL DRIVE

Trail one pedal drive allows you to accelerate and brake using only the accelerator pedal. The system assists when driving through difficult off-road terrain. Pressing the accelerator pedal down accelerates your vehicle and releasing pressure on the accelerator pedal, with your foot still on the pedal, slows your vehicle down. Releasing the accelerator pedal may allow your vehicle to come to a complete stop, some situations may require you to press the brake pedal to come to a complete stop.

TRAIL ONE PEDAL DRIVE PRECAUTIONS



WARNING: This system does not automatically brake your vehicle. This system is an extra driving aid. It does not replace your attention and judgment, or the need to apply the brakes. If you do not apply the brakes when necessary, you may collide with another vehicle or other objects.

Shifting into drive (D) or reverse (R) does not cause the vehicle to move.

You can press the brake pedal to increase braking. This does not turn the system off.

Trail one pedal drive could apply the parking brake when your vehicle is not moving and not in park (P).

Note: Always check the transmission selection before accelerating.

Note: Only use trail one pedal drive on slippery or loose surfaces. Using trail one pedal drive on dry, hard surfaces could produce some vibration, driveline bind up and potential excessive tire and vehicle wear.

Note: Trail one pedal drive helps get the most from your vehicle in off road situations. On high performance trim levels, trail one pedal drive may feel more aggressive.

TRAIL ONE PEDAL DRIVE LIMITATIONS

Trail one pedal drive is unavailable when any of the following occur:

- Your vehicle is not in four-wheel drive high (4H) or four-wheel drive low (4L) modes.
- Using cruise control.

- Using trail control.
- You exceed 30 mph (48 km/h).

Releasing the accelerator pedal may allow your vehicle to come to a complete stop, some situations may require you to press the brake pedal to come to a complete stop.

SWITCHING TRAIL ONE PEDAL DRIVE ON AND OFF

Switching Trail One Pedal Drive On



Press the trail features button when in four-wheel drive high or four-wheel drive low to activate trail one pedal drive.

Switching Trail One Pedal Drive Off

Press the trail features button again to switch trail one pedal drive off.

Selecting a driveline mode other than four-wheel drive high or four-wheel drive low switches trail one pedal drive off.

If you exceed 40 mph (65 km/h) trail one pedal drive switches off.

Trail Control (If Equipped)

SET+

Pressing either button when trail one pedal drive is active turns trail control on and places trail one pedal drive into standby mode.

SET-

Switching from Trail Control to Trail One Pedal Drive



When using trail control in four-wheel drive high or four-wheel drive low modes, you can switch to trail one pedal drive by pressing the button on the steering wheel.

TRAIL ONE PEDAL DRIVE INDICATORS



When trail one pedal drive is active, the indicator displays green in the instrument cluster. When the system is switched on but is unavailable or in standby mode, it displays grey.

TRAIL ONE PEDAL DRIVE – TROUBLESHOOTING

TRAIL ONE PEDAL DRIVE – INFORMATION MESSAGES

Message	Action
Trail 1-Pedal Drive Active Use SET Button for Trail Control	Displays when trail one pedal drive is active, use the SET+ or SET- to switch to trail control.
Trail Control with Trail 1- Pedal Drive Off	Displays when you switch trail one pedal drive off.
Trail Control Enabled Use SET button to Set Speed Trail 1-Pedal Drive Available in 4H or 4L	Trail control is in a driveline state not supported for trail one pedal drive. Set a speed to activate trail control or change the driveline state to four-wheel drive high (4H) or four-wheel drive low (4L) modes to activate trail one pedal drive.
Trail Control Active Use CANCEL button to resume Trail 1-Pedal Drive	Displays when trail control is active and allows you to resume using trail one pedal drive when you press the CANCEL button.

Trail Control (If Equipped)

TRAIL CONTROL – TROUBLESHOOTING

TRAIL CONTROL – INFORMATION MESSAGES

Message	Details
Reduce Speed To Enter Trail Control	Displays when you must reduce your vehicle speed to use trail control.
Trail Control Not Available with Park Brake Applied	Displays when you must release the park brake to use trail control.
Trail Control Not Available While Pro Trailer Backup Assist™ Active	Displays when you must switch off the trailer backup assist to use trail control.
Trail Control Off Driver Resume Control	Displays when a system fault has occurred when trail control was active and the driver must resume control.
Trail Control Fault See Manual	Displays when a system fault is present. See the trail control section in your Owner's Manual. See your authorized dealer for diagnosis.
Trail Control To Activate Select Gear	Displays when you must be in drive (D), neutral (N) or reverse (R) to use trail control.
Trail Control Not Available with Cruise Control Active	Displays when you must switch the cruise control off to use trail control.
Trail Control Not Available with Driver Door Open	Displays when you must close the driver door to use trail control.
Set Trail Control to 1 MPH to Aid in Getting Unstuck in Sand	Displays when the system detects you may be stuck in sand and recommends using trail control on to the lowest set speed. Doing this could slowly pull sand under the tires to free the vehicle.
Set Trail Control to 2 km/h to Aid in Getting Unstuck in Sand	
Descent Control Now Active Press Trail Control Switch To Exit	You switched off trail control propulsion; however, the system still applies the brakes if descending a hill. Press the trail control button to switch this feature off, you can then switch it back on.

Trail Control (If Equipped)

Message	Details
Trail Control Not Available with Seatbelt Off	The system requires you to put your seatbelt on before you can use the trail control feature.
Trail Control Active Use CANCEL button to resume Trail 1-Pedal Drive	Displays when only trail control is active and allows you to resume using trail one pedal drive.

Trail Turn Assist (If Equipped)

WHAT IS TRAIL TURN ASSIST

Trail turn assist can reduce the turning radius of your vehicle by applying the brakes to the inside rear wheel in low-speed, high steering-angle maneuvers.

TRAIL TURN ASSIST PRECAUTIONS

Note: Do not use trail turn assist on dry, hard surfaced roads. Doing so can produce excessive noise, increase tire wear and may damage drive line, or braking components. Trail turn assist is only intended for slippery, or loose surfaces.

You may hear noise from the anti-lock brake system while trail turn assist is active. This is normal operation.

TRAIL TURN ASSIST LIMITATIONS

Trail turn assist can only be used when the vehicle's four-wheel drive system is in the four-wheel drive high (4H), or four-wheel drive low (4L) modes.

Trail Turn Assist cannot be used when the vehicle's rear differential is locked. If the rear differential has recently been locked prior to Trail Turn Assist being turned on, Trail Turn Assist may not activate until it can confirm that the rear differential is unlocked.

SWITCHING TRAIL TURN ASSIST ON AND OFF

You can switch trail turn assist on or off from the touchscreen.

1. From the controls menu, switch Trail Turn Assist on or off.

Once switched on, trail turn assist activates when:

- Vehicle speed is less than 12 mph (19.3 km/h).
- Vehicle is in four-wheel drive high (4H) or four-wheel drive low (4L).
- Steering wheel is almost fully turned to the left or right.
- Rear differential is fully unlocked.

You can deactivate trail turn assist by performing any of the following:

- Selecting two-wheel drive high (2H) or four-wheel drive auto (4A).
- Reducing the steering wheel input.
- Switch on the rear locking differential.

Trail turn assist remains on, even if deactivated, until you switch it off in the touchscreen. You can switch off trail turn assist through the touchscreen at any time.

TRAIL TURN ASSIST INDICATORS



When trail turn assist is on, one of these two indicators will be displayed, depending on the direction of the vehicle's last turn. When the feature is available but not in use, the indicator will be gray.

When the feature is active the indicator will be green.

Trail Turn Assist (If Equipped)

TRAIL TURN ASSIST – TROUBLESHOOTING

TRAIL TURN ASSIST – INFORMATION MESSAGES

Message	Details
Trail Turn Assist Available in 4L or 4H	Switch to four-wheel drive low (4L) or four-wheel drive high (4H) to activate trail turn assist. See Selecting a Four-Wheel Drive Mode (page 199).
Trail Turn Assist Not Available See Manual	Trail turn assist system malfunction could be present. If this condition persists, have your vehicle serviced.
Trail Turn Assist ON	You have activated trail turn assist.
Trail Turn Assist OFF	You have switched trail turn assist off.

TRAIL TURN ASSIST – FREQUENTLY ASKED QUESTIONS

Why does Trail Turn Assist not activate after unlocking the rear differential?

The rear differential may not be fully disengaged. When possible, turn off the rear axle locker while driving straight before using trail turn assist. If you are already in a tight turn when you encounter this situation, driving the vehicle for a short distance in reverse could allow the differential to fully disengage.

Hill Descent Control (If Equipped)

WHAT IS HILL DESCENT CONTROL

Hill descent control allows the driver to set and maintain vehicle speed while descending steep slopes in various surface conditions.

HOW DOES HILL DESCENT CONTROL WORK

Hill descent control can maintain vehicle speeds on downhill slopes between 2–20 mph (3–32 km/h). Above 20 mph (32 km/h), the system remains on but the descent speed cannot be set or maintained.

Note: *The system does not function below 2 mph (3 km/h).*

The system requires a cool down interval after a period of sustained use. Hill descent control provides a warning in the message center and a tone sounds when the system is about to disengage for cooling. At this time, manually apply the brakes as needed to maintain descent speed.

Note: *The amount of time that the system can remain active before cooling varies with conditions.*

HILL DESCENT CONTROL PRECAUTIONS



WARNING: The system does not control speed in low traction conditions or extremely steep slopes. The system is designed to be an aid and does not relieve you of your responsibility to drive with due care and attention. Failure to follow this instruction could result in personal injury.



WARNING: Hill descent control cannot control descent in all surface conditions and circumstances, such as ice or extremely steep grades. Hill descent control is a driver assist system and cannot substitute for good judgment by the driver. Failure to do so may result in loss of vehicle control, crash or serious injury.



WARNING: The system does not replace the parking brake. When you leave your vehicle, always apply the parking brake and shift the transmission into park (P) for automatic transmission or first gear for manual transmission.

SWITCHING HILL DESCENT CONTROL ON AND OFF



Press the button on the center console. A light illuminates in the control and a tone sounds when the system is active.

SETTING THE HILL DESCENT SPEED

To increase or decrease the descent speed, press the accelerator or brake pedal, or use the SET + and SET - buttons on the steering wheel. Once you reach the preferred speed remove your feet from the pedals.

HILL DESCENT CONTROL INDICATOR



Illuminates when you switch hill descent control on.

Hill Descent Control (If Equipped)

HILL DESCENT CONTROL – TROUBLESHOOTING

HILL DESCENT CONTROL – INFORMATION MESSAGES

Message	Action
For Hill Descent Reduce Speed XX MPH/km/h or Less	Your vehicle speed requirement for off-road mode entry has not been met.
For Hill Descent Select Gear	You need to select a transmission gear for hill descent mode.
Hill Descent Driver Resume Control	Hill descent control mode is deactivated and you must resume control.
Hill Descent Control Fault	A hill descent system fault is present.
Hill Descent Control Off System Cooling	The hill descent system is cooling due to overuse.
Hill Descent Control not available with Cruise Control Active	The hill descent system cannot activate while Cruise Control is actively controlling speed.

Steering

ELECTRIC POWER STEERING

HOW DOES ELECTRIC POWER STEERING WORK

The electric power steering system assists the brake system to help operate advanced stability control and accident avoidance systems.

If your vehicle loses electrical power or detects a concern when you are driving, the system switches to reduced steering assist or manual steering. Additionally, whenever disconnecting the battery or installing a new one, you must drive your vehicle a short distance before the system relearns the strategy and reactivates all systems.

ELECTRIC POWER STEERING PRECAUTIONS



WARNING: The electric power steering system has diagnostic checks that continuously monitor the system. If a fault is detected, a message displays in the information display. Stop your vehicle as soon as it is safe to do so. Switch the

vehicle off. After at least 10 seconds, switch the vehicle on and watch the information display for a steering system warning message. If a steering system warning message returns, have the system checked as soon as possible.



WARNING: If the system detects an error, you may not feel a difference in the steering, however a serious condition may exist. Have your vehicle checked as soon as possible. Failure to do so may result in loss of steering control.

Adapt your speed and driving behavior according to reduced steering assist.

Extreme continuous steering may increase the effort to steer. This occurs to prevent internal overheating and damage to the steering system. If this occurs, you will not lose the ability to steer your vehicle manually nor will it cause damage to the system. Normal steering and driving allows the system to cool down and steering assist returns to normal.

Note: *There is no fluid reservoir to check or fill.*

When your vehicle is still moving, a significant decrease in steering assistance or a loss of steering assistance could occur if:

- You switch your vehicle off.
- Your vehicle loses electrical power.
- Your vehicle detects a concern.

When your vehicle is off and your vehicle begins moving, there is no steering assistance.

STEERING – TROUBLESHOOTING

STEERING – WARNING LAMPS



The electric power steering system indicator illuminates if the system detects a fault during the continuous diagnostic checks.

Note: *If a red warning message displays, stop your vehicle as soon as it is safe to do so.*

Steering

STEERING – INFORMATION MESSAGES

Message	Action
Steering Fault Service Now	The power steering system has detected a condition that requires service. Have your vehicle checked as soon as possible.
Steering Loss Stop Safely	The power steering system is not working. Stop your vehicle in a safe place. Have your vehicle checked as soon as possible.
Steering Assist Fault Service Required	The power steering system has detected a condition that requires service. Have your vehicle checked as soon as possible.
Steering Lock Malfunction Service Now	The steering system has detected a condition that requires service. Have your vehicle checked as soon as possible.

Steering

STEERING – FREQUENTLY ASKED QUESTIONS

Why does it seem that the steering is wandering or pulling?

- Check your vehicle for an improperly inflated or uneven tire, loose or worn suspension or steering components, or improper vehicle alignment.

The system is functioning properly and the components have been checked, why is the steering system continuing to pull or wander?

- A high crown in the road or crosswinds could make the steering system feel like it is wandering or pulling.

Parking Aids

PARKING AID PRECAUTIONS

 **WARNING:** To help avoid personal injury, always use caution when in reverse (R) and when using the sensing system.

 **WARNING:** The system may not detect objects with surfaces that absorb reflection. Always drive with due care and attention. Failure to take care may result in a crash.

 **WARNING:** Traffic control systems, fluorescent lamps, inclement weather, air brakes, external motors and fans may affect the correct operation of the sensing system. This may cause reduced performance or false alerts.

 **WARNING:** The system may not detect small or moving objects, particularly those close to the ground.

 **WARNING:** The parking aid system can only assist you to detect objects when your vehicle is moving at parking speeds. To help avoid personal injury you must take care when using the parking aid system.

 **WARNING:** The system may not function if the sensor is blocked.

 **WARNING:** In cold and severe weather conditions the system may not function. Rain, snow and spray can all limit sensor performance.

 **WARNING:** If damage occurs in the immediate area surrounding the sensor, have your vehicle checked as soon as possible.

Note: *If your vehicle sustains damage leaving the sensors misaligned, this will cause inaccurate measurements or false alerts.*

When you connect a trailer to your vehicle, the rear parking aid detects the trailer and provides an alert. Disable the parking aid when you connect a trailer to prevent the alert.

Note: *Connected trailers might be detected by the vehicle and parking aid turns off automatically in those instances.*

Note: *Certain add-on devices installed around the bumper or fascia may create false alerts. For example, large trailer hitches, bike or surfboard racks, license plate brackets, bumper covers or any other device could block the normal detection zone of the parking aid system. Aftermarket spare tires or spare tire covers mounted to the rear tailgate could cause false alerts from the park aid system. Remove the add-on device to prevent false alerts.*

Note: *Keep the sensors free from snow, ice and large accumulations of dirt. If the sensors are covered, the system's accuracy can be affected.*

Do not clean the sensors with sharp objects.

SWITCHING PARKING AID ON AND OFF

Muting the Audible Tone

 Press the parking aid button and use the menu to switch the system's audible tone on and off.

 You can also switch the tone on and off by shifting into reverse (R) and pressing the button on the rear view camera display screen.

Parking Aids

REAR PARKING AID

WHAT IS THE REAR PARKING AID

Rear parking sensors detect objects behind your vehicle when in reverse (R).

REAR PARKING AID LIMITATIONS

There is a decreased coverage area at the outer corners.

The rear parking aid sensors are active when your vehicle is in reverse (R) and the vehicle speed is less than 5 mph (8 km/h).

The sensor coverage area is up to 71 in (180 cm) from the rear bumper.

The rear parking aid detects large objects when you shift into reverse (R) and any of the following occur:

- Your vehicle is moving backward at a low speed.
- Your vehicle is stationary but an object is approaching the rear of your vehicle at a low speed.
- Your vehicle is moving backward at a low speed and an object is moving towards your vehicle, for example another vehicle at a low speed.

The system shall provide no audible warning for the object behind the vehicle when in neutral (N) gear.

LOCATING THE REAR PARKING AID SENSORS



The rear parking aid sensors are in the rear bumper.

REAR PARKING AID AUDIBLE WARNINGS

A warning tone sounds when your vehicle approaches an object. As your vehicle moves closer to an object, the rate of the tone increases. The warning tone continuously sounds when an object is 12 in (30 cm) or less from the rear bumper.

If your vehicle remains stationary for a few seconds, the audible warning turns off. If your vehicle moves backward the tone sounds again.

Note: *When the parking aid system sounds a tone, the audio system may reduce the set volume.*

FRONT PARKING AID

WHAT IS THE FRONT PARKING AID

Front parking sensors detect objects in front of your vehicle.

Parking Aids

FRONT PARKING AID LIMITATIONS

The front parking aid sensors are active when your vehicle is in any position other than park (P) and the vehicle speed is less than 5 mph (8 km/h).

The sensor coverage area is up to 28 in (70 cm) from the front bumper.

If your vehicle is in reverse (R), the front parking aid detects objects and provides an audible warning when your vehicle is moving at a low speed and when an object is moving toward your vehicle, for example, another vehicle at a low speed. If your vehicle remains stationary for a few seconds, the audible warning turns off. Visual indication is always active in reverse (R).

If your vehicle is in any forward gear, the front parking aid provides audible warnings and a visual indication when your vehicle is moving at a speed of 5 mph (8 km/h) or below and the system detects an object within the detection zone. If your vehicle remains stationary for a few seconds, the visual indication and audible warning turns off.

If your vehicle is in neutral (N), the front and rear sensors provide a visual indication only when your vehicle is moving below a speed of 5 mph (8 km/h) and the system detects obstacles inside the detection areas. Once your vehicle stops, the visual indication and audible warning stops after a few seconds.

LOCATING THE FRONT PARKING AID SENSORS



The front parking aid sensors are in the front bumper.

FRONT PARKING AID AUDIBLE WARNINGS

A warning tone sounds when there is an object within 28 in (70 cm) from the front bumper. As your vehicle moves closer to an object, the rate of the tone increases.

The warning tone continuously sounds when an object is 12 in (30 cm) or less from the front bumper.

Note: *If the detected object is 12 in (30 cm) or less from your vehicle, visual indication remains on.*

Parking Aids

PARKING AID INDICATORS

Parking Aid Indicators Shown When 360 Degree Camera Views are not Available



The system provides object distance indication through the touchscreen.

- As the distance to an object decreases, the indicators change color. The indicators for closer objects appear closer to the vehicle icon.
- The indicators are green when the object is at the farthest detection point. As the object gets closer, the indicators turn amber. When the object is at the closest detection point, the indicators turn red.
- If there is no object detected, the distance indicators are not activated.

The activated visual indicators continue displaying when your vehicle is stopped in reverse (R). If stopped in drive (D) or neutral (N), the activated visual indicators disappear after four seconds.

Note: *If stopped in drive (D) or neutral (N) with rear camera delay mode showing the rear camera view, the activated visual indicators continue displaying.*

Parking aids are not available in the following situations:

- The system is switched off.
- A trailer is connected.
- Sensors are blocked.
- A system fault occurs.

Note: *If the parking aids are not available, the distance indicators do not display. See **Parking Aids – Troubleshooting** (page 247).*

Note: *Front park aid indicators may not be available.*

Parking Aid Indicators Shown in 360 Degree Camera Views (If Equipped)

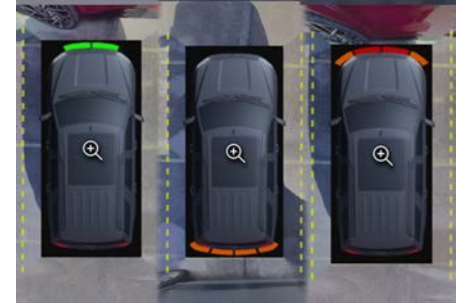

The system provides object distance indication through the touchscreen.

Parking Aids

- As the distance to an object decreases, the indicators change color.
- The indicators are green when the object is at the farthest detection point. As the object gets closer, the indicators turn amber. When the object is at the closest detection point, the indicators turn red.
- If there is no object detected, the distance indicators are not activated.

The activated visual indicators continue displaying when your vehicle is stopped in reverse (R). If stopped in drive (D) or neutral (N), the activated visual indicators disappear after four seconds.

Note: *If stopped in drive (D) or neutral (N) with rear camera delay mode showing the rear camera view, the activated visual indicators continue displaying.*

Parking aids are not available in the following situations:

- The system is switched off.
- A trailer is connected.
- Sensors are blocked. The distance indicators appear white.
- A system fault occurs.

Note: *If the parking aids are not available, the distance indicators do not display. See **Parking Aids – Troubleshooting** (page 247).*

PARKING AIDS – TROUBLESHOOTING

PARKING AIDS – INFORMATION MESSAGES

If a fault is present in the parking aids, a warning message appears in the instrument cluster or the touchscreen.

Message	Action
Park Aid Fault	The system detects a condition that requires service. Have your vehicle checked as soon as possible. You may be able to resolve by cleaning the sensors and restarting your vehicle.
Parking Sensors Blocked	Inclement weather, ice, mud, or water is blocking the sensor, causing the system to become unavailable. You can typically clean the sensor to resolve.
Trailer Connected	An electrical trailer connection is sensed during a given ignition cycle.

Rear View Camera

WHAT IS THE REAR VIEW CAMERA

The rear view camera provides a video image of the area behind your vehicle when the transmission is in reverse (R).



You can access the rear view camera by pressing the button on the touchscreen.

REAR VIEW CAMERA PRECAUTIONS



WARNING: The rear view camera system is a reverse aid supplement device that still requires the driver to use it in conjunction with the interior and exterior mirrors for maximum coverage.



WARNING: Objects that are close to either corner of the bumper or under the bumper, might not be seen on the screen due to the limited coverage of the camera system.



WARNING: Objects above the camera may not be visible. Check the area behind your vehicle when necessary.



WARNING: Reverse your vehicle slowly. Failure to follow this instruction could result in the loss of control of your vehicle, personal injury or death.



WARNING: Use caution when the liftgate or tailgate is ajar. If the liftgate or tailgate is ajar, the camera will be out of position and the video image could be incorrect. All guide lines disappear when the liftgate or tailgate is ajar. Failure to follow this instruction could result in personal injury.



WARNING: Do not switch the camera features on or off when your vehicle is moving.

Note: *When towing, the camera only sees what you are towing. This might not provide adequate coverage and you might not see some objects. In some vehicles, the guidelines may disappear when you connect the trailer tow connector.*

LOCATING THE REAR VIEW CAMERA

The rear view camera is on the liftgate or tailgate. It provides a view of the area behind your vehicle.

Rear View Camera

REAR VIEW CAMERA GUIDE LINES

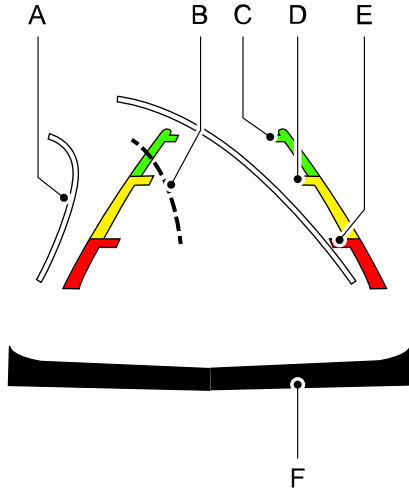

- A Active guide lines.
- B Centerline.
- C Fixed guide line: Green zone.

- D Fixed guide line: Yellow zone.
- E Fixed guide line: Red zone.
- F Rear bumper.

Active guide lines only show with fixed guide lines. To use active guide lines, turn the steering wheel to point the guide lines toward an intended path. If the steering wheel position changes while reversing, your vehicle might deviate from the intended path.

The fixed and active guide lines fade in and out depending on the steering wheel position. The active guide lines do not display when the steering wheel position is straight.

Use caution while reversing. Objects in the red zone are closest to your vehicle and objects in the green zone are farther away. Objects get closer to your vehicle as they move from the green zone to the yellow or red zones. Use the side view mirrors and rear view mirror to get better coverage on both sides and rear of your vehicle.

Note: Active guide lines and fixed guide lines are only available when the transmission is in reverse (R).

Note: The centerline is only available if the active or fixed guide lines are on.

Note: Not all camera modes work properly without an auxiliary camera.

REAR VIEW CAMERA SETTINGS

ZOOMING THE REAR VIEW CAMERA IN AND OUT



WARNING: When manual zoom is on, the full area behind your vehicle may not show. Be aware of your surroundings when using the manual zoom feature.

Selectable settings for this feature are zoom in (+) and zoom out (-). Press the symbol on the camera screen to change the view. The default setting is zoom off.

This allows you to get a closer view of an object behind your vehicle. The zoomed image keeps the bumper in the image to provide a reference. The zoom is only active while the transmission is in reverse (R).

Note: Zooming in also engages park hold which applies the electric park brake when you shift to park (P). When you press the zoom button, the electronic park hold button illuminates on the touchscreen. See **Connecting a Trailer** (page 330).

Rear View Camera

Note: Manual zoom is only available when the transmission is in reverse (R).

Note: Only the centerline shows when you enable manual zoom.

SWITCHING REAR VIEW CAMERA DELAY ON AND OFF

You can switch rear view camera delay on and off under the settings menu, and then the driver assistance menu.

When shifting the transmission out of reverse (R) and into any gear other than park (P), the camera image remains in the display until the vehicle speed reaches approximately 5 mph (8 km/h) or you shift your vehicle into park (P).

SWITCHING THE REAR VIEW CAMERA VIEW



Rear normal view provides a view of what is directly behind your vehicle. This view is available at all speeds in reverse (R), drive (D) and neutral (N). When your vehicle is not in reverse (R), this view may be displayed with different text or graphics.



Rear split view provides a wide-angle view of what is behind your vehicle.



The hitch view provides a wide-angle view of the area around the tow hitch. This view is available at all speeds in reverse (R), drive (D) and neutral (N).



Trailer AUX camera shows a view of what is behind your trailer. This camera is purchased and installed separately.



Zooms in on the view and park hold is activated when your vehicle is in park (P). See **Connecting a Trailer** (page 330).

360 Degree Camera

WHAT IS THE 360 DEGREE CAMERA

The 360 degree camera system consists of front, side and rear cameras which provide visibility around your vehicle.

HOW DOES THE 360 DEGREE CAMERA WORK

The 360 degree camera system:

- Allows you to see what is directly in front of or behind your vehicle.
- Helps you when parallel parking and centering in a parking space.
- Provides a cross traffic view in front of and behind your vehicle.
- Allows you to see a top-down view of the area outside your vehicle, including the blind spots and obstacles near your vehicle.

360 DEGREE CAMERA PRECAUTIONS

 **WARNING:** The 360 degree camera system still requires the driver to use it in conjunction with looking out of the windows, and checking the interior and exterior mirrors for maximum coverage.

 **WARNING:** Objects that are close to either corner of the bumper or under the bumper, might not be seen on the screen due to the limited coverage of the camera system.

 **WARNING:** Use caution when turning camera features on or off when the transmission is not in park (P). Make sure your vehicle is not moving.

 **WARNING:** You are responsible for controlling your vehicle at all times. The system is designed to be an aid and does not relieve you of your responsibility to drive with due care and attention. Failure to follow this instruction could result in the loss of control of your vehicle, personal injury or death.



WARNING: Use caution when the rear cargo door is ajar. If the rear cargo door is ajar, the camera will be out of position and the video image could be incorrect. All guide lines disappear when the rear cargo door is ajar. Failure to follow this instruction could result in personal injury.



WARNING: When manual zoom is on, the full area behind your vehicle may not show. Be aware of your surroundings when using the manual zoom feature.

360 DEGREE CAMERA LIMITATIONS

Note: Use caution if a door is ajar. The camera could be out of position and the image could be incorrect.

LOCATING THE 360 DEGREE CAMERAS

Rear View Camera

The rear view camera is on the liftgate or tailgate. It provides a view of the area behind your vehicle.

360 Degree Camera

Front View Camera

The front view camera is in the grille. It provides a view of the area in front of your vehicle.

Side View Camera

The side view camera is on the outside mirror. It provides a view of the area on the sides of your vehicle.

360 DEGREE CAMERA GUIDE LINES

Note: Active guide lines are only available when the transmission is in reverse (R).

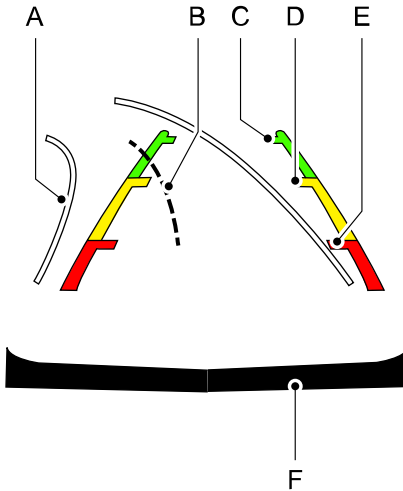

- A Active guide lines.
- B Centerline.
- C Fixed guide line: Green zone.
- D Fixed guide line: Yellow zone.

- E Fixed guide line: Red zone.
- F Rear bumper.

Active guide lines only show with fixed guide lines. Turn the steering wheel to point the guide lines toward an intended path. If the steering wheel position changes when reversing, your vehicle could deviate from the intended path.

The fixed and active guide lines fade in and out depending on the steering wheel position. The active guide lines do not display when the steering wheel position is straight.

Objects in the red zone are closest to your vehicle and objects in the green zone are farther away. Objects get closer to your vehicle as they move from the green zone to the yellow or red zones. Use the side view mirrors and rear view mirror to get better coverage on both sides and rear of your vehicle.

360 Degree Camera

Keep Out Zone

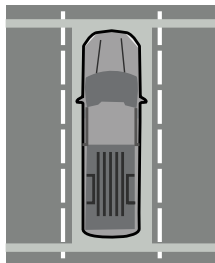

The keep out zone is represented by the yellow dotted lines running parallel to your vehicle.

360 DEGREE CAMERA SETTINGS

SWITCHING THE 360 DEGREE CAMERA ON AND OFF



The 360 degree camera system button is located near the touchscreen and allows you to toggle the front camera on or off. The front and rear cameras have multiple screens which consist of:

- Normal view.
- Normal view with 360.
- Split view.

Note: *The rear view camera activates when you switch into reverse (R). Additional views are then accessible on the touchscreen.*

When in park (P), neutral (N) or drive (D), only the front views display when you press the camera button. When in reverse (R), only the rear views display when you press the button.

Note: *The front camera views remain on when your vehicle is in motion at low speed. The rear camera views remain on at all speeds when in reverse (R). Some rear camera views are available in neutral (N) and in drive (D) at all speeds.*

SWITCHING THE 360 DEGREE CAMERA VIEW



Front normal view provides a view of what is directly in front of your vehicle.



Front split view provides a wide-angle view of what is in front of your vehicle.



Normal + 360 degree view contains the normal camera view next to a 360 degree camera view.



Rear normal view provides a view of what is directly behind your vehicle. The rear normal view is available at all speeds in reverse (R), drive (D), and neutral (N). When not in reverse (R), this view may display with differentiating text or graphics.

360 Degree Camera



Rear split view provides a wide-angle view of what is behind your vehicle.



The hitch view provides a view of the area around the tow hitch. View is available at all speeds in reverse (R), drive (D), and neutral (N).



Trailer reverse guidance shows the sides of your truck and trailer. See **Trailer Reverse Guidance** (page 362).



50/50 split view provides a view of both sides of your vehicle and trailer, if connected. This view is available at all speeds in park (P), neutral (N), and drive (D).



Zooms in on the rear normal view and park hold activates when you shift your vehicle to park (P). See

Connecting a Trailer (page 330).



Provides access to multiple zoom options by touching the zoom button on the 360 degree camera view. View options include the ability to zoom to your vehicle corners or to the front or rear of your vehicle. Depending on what gear and which drive mode you select, guidelines may be available. See **360 Degree Camera Guide Lines** (page 252).

Note: *The hitch view, rear camera view, and 50/50 view are available at all speeds.*

Automatic Camera Views

When using the turn signals, a view from the corresponding side camera displays on the screen.

When front park aid distance indicators reach the red zone, the front camera automatically displays a view of the area ahead of your vehicle.

When entering off-road drive modes, a front camera view automatically displays with vehicle path guidelines.

Adaptive Cruise Control

HOW DOES ADAPTIVE CRUISE CONTROL WITH STOP AND GO WORK

Adaptive cruise control with stop and go uses radar and camera sensors to maintain a set gap between your vehicle and the vehicle in front of you while following it to a complete stop. Stop and go can also be set to follow a vehicle directly in front of you and adjust the set speed, while you are at a complete stop.

ADAPTIVE CRUISE CONTROL PRECAUTIONS

 **WARNING:** You are responsible for controlling your vehicle at all times. The system is designed to be an aid and does not relieve you of your responsibility to drive with due care and attention. Failure to follow this instruction could result in the loss of control of your vehicle, personal injury or death.

 **WARNING:** Do not use adaptive cruise control on winding roads, in heavy traffic or when the road surface is slippery. This could result in loss of vehicle control, serious injury or death.

 **WARNING:** Pay close attention to changing road conditions such as entering or leaving a highway, on roads with intersections or roundabouts, roads without visible lanes of travel, roads that are unpaved, or steep slopes. Failure to follow this instruction could result in the loss of control of your vehicle, personal injury or death.

 **WARNING:** The system is not a crash warning or avoidance system.

 **WARNING:** Do not use the system when towing a trailer that has aftermarket electronic trailer brake controls. Failure to follow this instruction could result in the loss of control of your vehicle, personal injury or death.

 **WARNING:** Do not use tire sizes other than those recommended because this can affect the normal operation of the system. Failure to do so may result in a loss of vehicle control, which could result in serious injury.

 **WARNING:** Do not use the system with a snow plow blade installed.

 **WARNING:** In situations with poor visibility, such as fog, heavy rain or other inclement weather, you may need to override or completely switch off the system.

When Following a Vehicle

 **WARNING:** When following a vehicle that is braking, your vehicle does not always decelerate quickly enough to avoid a crash without driver intervention. Apply the brakes when necessary. Failure to follow this instruction could result in personal injury or death.

Adaptive Cruise Control

Hilly Condition Usage

Select a lower gear when the system is active in situations such as prolonged downhill driving on steep slopes, for example in mountainous areas.

ADAPTIVE CRUISE CONTROL LIMITATIONS

Sensor Limitations

WARNING: On rare occasions, detection issues can occur due to the road infrastructures, for example bridges, tunnels and safety barriers. In these cases, the system may brake late or unexpectedly. At all times, you are responsible for controlling your vehicle, supervising the system and intervening, if required.

WARNING: If the system malfunctions, have your vehicle checked as soon as possible.

WARNING: Large contrasts in outside lighting can limit sensor performance.

WARNING: The system only warns of vehicles detected by the radar sensor. In some cases there may be no warning or a delayed warning. Apply the brakes when necessary. Failure to follow this instruction could result in personal injury or death.

WARNING: The system may not detect stationary or slow moving vehicles below 6 mph (10 km/h).

WARNING: The system does not detect pedestrians or objects in the road.

WARNING: The system does not detect oncoming vehicles in the same lane.

WARNING: The system may not operate properly if the sensor is blocked. Keep the windshield free from obstruction.

WARNING: The system may incorrectly track lane markings as other structures or objects. This can result in a false or missed warning.

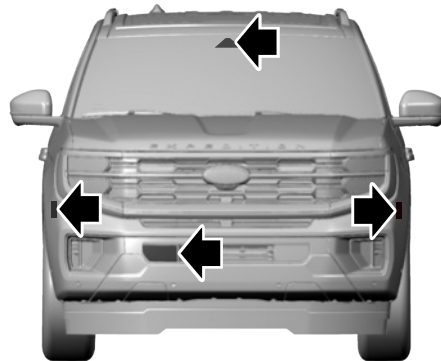

1. Camera.
2. Radar sensor.

The camera is on the windshield behind the interior mirror.

The radar sensor is in the lower grille.

Note: You cannot see the sensor. It is behind a fascia panel.

Note: Keep the front of your vehicle free of dirt, metal badges or objects. Vehicle front protectors, aftermarket lights, additional paint or plastic coatings could also degrade sensor performance.

Adaptive Cruise Control

A message displays if something obstructs the camera or the sensor. When something blocks the sensor, the system cannot detect a vehicle ahead and does not function. See **Adaptive Cruise Control – Information Messages** (page 270).

The radar sensor has a limited field of view. It may not detect vehicles at all or detect a vehicle later than expected in some situations. The lead vehicle image does not illuminate if the system does not detect a vehicle in front of you.

Adaptive Cruise Control

Detection Issues Can Occur:

A

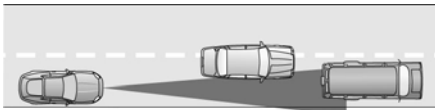

B

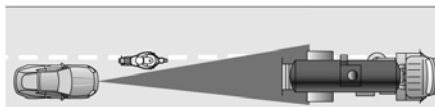

C

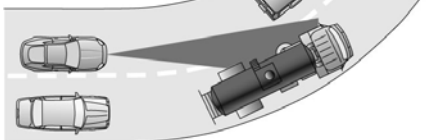

- A When driving on a different line than the vehicle in front.
- B With vehicles that edge into your

lane. The system can only detect these vehicles once they move fully into your lane.

- C There may be issues with the detection of vehicles in front when driving into and coming out of a bend or curve in the road.

In these cases, the system may unexpectedly brake or brake late.

If something hits the front end of your vehicle or damage occurs, the radar-sensing zone may change. This could cause missed or false vehicle detection.

Optimal system performance requires a clear view of the road by the windshield camera.

Optimal performance may not occur if:

- The camera is blocked.
- There is poor visibility or lighting conditions.
- There are bad weather conditions.

SWITCHING ADAPTIVE CRUISE CONTROL ON AND OFF

The cruise controls are on the steering wheel.

Switching Adaptive Cruise Control On



Press the button to activate the system. When the system activates, the set speed is equal to whichever is greater, the current vehicle speed, or 15 mph (20 km/h). If the speed is too low, or other conditions are not correct for adaptive cruise control activation, the system enters standby mode. When you are below 15 mph (20 km/h), adaptive cruise control does not activate unless you are following another vehicle.

The indicator, current gap setting and set speed appear in the instrument cluster display.

Switching Adaptive Cruise Control Off



Press the button when the system is active or switch the vehicle off.

Note: When you switch the system off, the set speed clears.

Adaptive Cruise Control

ADAPTIVE CRUISE CONTROL AUTOMATIC CANCELLATION

The system may cancel if:

- The tires lose traction.
- You apply the parking brake.

The system may cancel and set the parking brake if:

- You unbuckle the seatbelt and open the driver door after adaptive cruise control stops your vehicle.
- Adaptive cruise control holds your vehicle at a stop continuously for more than three minutes.

The system may deactivate or prevent activating when requested if:

- The vehicle has a blocked sensor.
- The brake temperature is too high.
- There is a failure in the system or a related system.

SETTING THE ADAPTIVE CRUISE CONTROL SPEED

Drive to the speed you prefer.

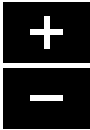

Press either button to set the current speed.

Take your foot off the accelerator pedal.

The indicator, current gap setting and set speed appear in the instrument cluster display.



A vehicle image illuminates if there is a vehicle detected in front of you.

Note: When adaptive cruise control is active, the speedometer may vary slightly from the set speed displayed in the instrument cluster display.

Setting the Adaptive Cruise Speed from a Complete Stop

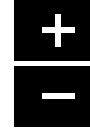

Press the + or - buttons while keeping the brake pedal fully depressed.

The set speed adjusts to 15 mph (20 km/h).

The indicator, current gap setting and set speed appear in the instrument cluster display.

Note: The system activates from a complete stop only when it detects a lead vehicle in close proximity.

Manually Changing the Set Speed



Press the button to increase the set speed in small increments. Press and hold the button to increase the set speed in large increments. Release the button when the set speed is equal to the desired speed.



Press the button to decrease the set speed in small increments. Press and hold the button to decrease the set speed in large increments. Release the button when the set speed is equal to the desired speed.

Adaptive Cruise Control

You can also press the accelerator or brake pedal until you reach the speed you prefer. Press either button to select the current speed as the set speed.

The system could apply the brakes to slow your vehicle to the new set speed. The set speed continuously displays in the instrument cluster display when the system is active.

Setting the Adaptive Cruise Speed from Standby Mode



Press the button from standby mode to set the cruise control speed to the current vehicle speed.

SETTING THE ADAPTIVE CRUISE CONTROL GAP

You can decrease or increase the distance between your vehicle and the vehicle in front by pressing the gap control.



Press the button to increase the gap setting.



Press the button to decrease the gap setting.



The selected gap appears in the instrument cluster display as shown by the bars in the image.

Note: The gap setting is time dependent and therefore, the distance adjusts with your vehicle speed.

Note: It is your responsibility to select a gap appropriate to the driving conditions.

Adaptive Cruise Control Gap Settings

Graphic Display, Bars Indicated Between Vehicles	Gap Distance	Dynamic Behavior
1	Closest	Sport
2	Close	Normal
3	Medium	Normal
4	Far	Comfort

Each time you switch the system on, it selects the last chosen gap setting.

Following a Vehicle

When a vehicle ahead of you enters the same lane or a slower vehicle is ahead in the same lane, the vehicle speed adjusts to maintain the gap setting.

Note: When you are following a vehicle and you switch on a turn signal, adaptive cruise control may provide a temporary acceleration to help you pass.

Adaptive Cruise Control

Your vehicle maintains a consistent gap from the vehicle ahead until:

- The vehicle in front of you accelerates to a speed above the set speed.
- The vehicle in front of you moves out of the lane you are in.
- You set a new gap distance.

The system applies the brakes to slow down your vehicle to maintain a safe gap distance from the vehicle in front of you. The system only applies limited braking. You can override the system by applying the brakes.

Note: *The brakes may emit noise when applied by the system.*

If the system determines that its maximum braking level is not sufficient, an audible warning sounds, a message appears in the instrument cluster display and an indicator flashes when the system continues to brake. Take immediate action.

CANCELING THE SET SPEED

CNL

Press the button or tap the brake pedal.

The set speed does not erase.

RESUMING THE SET SPEED

RES

Press the button.

The vehicle speed returns to the previously set speed and gap setting. The set speed displays continuously in the information display when the system is active.

Note: *Only use resume if you are aware of the set speed and intend to return to it.*

Resuming the Set Speed from a Complete Stop

Without an Active BlueCruise Service Plan:

If your vehicle follows a vehicle to a complete stop and remains stationary for less than a few seconds, your vehicle accelerates from a stationary position to follow the vehicle ahead.

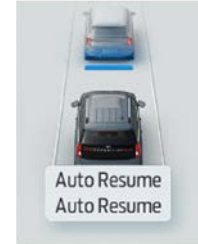

With an Active BlueCruise Service Plan:

If your vehicle follows a vehicle to a complete stop and remains stationary for less than approximately three minutes, your vehicle accelerates from a stationary position to follow the vehicle ahead.

The following conditions must be met before your vehicle auto-resumes:

- You are facing forward and paying attention to the road ahead.
- The road is clear of obstacles such as pedestrians or other vehicles crossing your path.

Adaptive Cruise Control

If your vehicle follows a vehicle to a complete stop and remains stationary for more than a

few seconds, an indicator and message displays.

Information Messages

Message	Details
Auto-Resume	(Only available with an active BlueCruise service plan). The vehicle is stopped behind a lead vehicle and all conditions are met for the vehicle to accelerate with the lead vehicle once the lead vehicle begins to accelerate.
Press button to resume	If the lead vehicle begins to move and all of the auto-resume conditions are not met, you are prompted to press the resume button. Pay attention to the road ahead and surroundings to make sure that it is safe to resume. Press and release the button or use the accelerator pedal to resume following the lead vehicle.
Stopped	Cruise control does not automatically resume when this display is active. Use the accelerator pedal to resume.

Note: *If approximately three minutes at a stop is exceeded, the vehicle cancels adaptive cruise control and the electric parking brake is set. The driver is required to resume control of the vehicle and release the electric parking brake.*

OVERRIDING THE SET SPEED



WARNING: If you override the system by pressing the accelerator pedal, it does not automatically apply the brakes to maintain a gap from any vehicle ahead.

When you press the accelerator pedal, you override the set speed and gap distance.

Use the accelerator pedal to intentionally exceed the set speed limit.

When you override the system, the indicator remains blue, the set speed is dimmed and the lead vehicle icon does not appear in the instrument cluster display.

Adaptive Cruise Control

The system resumes operation when you release the accelerator pedal. The vehicle speed decreases to the set speed, or a lower speed if following a slower vehicle.

ADAPTIVE CRUISE CONTROL INDICATORS



Illuminates when you switch adaptive cruise control on. The color of the indicator changes to indicate the system status.

White indicates the system is on but inactive.
Blue indicates that you set the speed and the system is active.

SWITCHING FROM ADAPTIVE CRUISE CONTROL TO CRUISE CONTROL



WARNING: Normal cruise control will not brake when your vehicle is approaching slower vehicles. Always be aware of which mode you have selected and apply the brakes when necessary.

1. From the settings menu, press Driver Assistance.
2. Press Cruise Control.
3. Press Normal Cruise Control.



The cruise control indicator replaces the adaptive cruise control indicator if you select normal cruise control. The gap setting does not display, and the system does not respond to lead vehicles. Automatic braking remains active to maintain set speed. The system remembers the last setting when you start your vehicle.

LANE CENTERING

HOW DOES LANE CENTERING WORK

Adaptive cruise control with lane centering uses the vehicle's front radar sensor and front windshield camera sensor, together with the steering sensor to operate.

Using these sensors, the system applies continuous steering assistance towards driving in the middle of the lane.

Note: *The gap setting for adaptive cruise control with lane centering, operates in the same way as normal adaptive cruise control.*

LANE CENTERING PRECAUTIONS



WARNING: Do not use the system when towing a trailer. Failure to follow this instruction could result in the loss of control of your vehicle, personal injury or death.



WARNING: Do not use the system if any changes or modifications to the steering wheel have been made. Any changes or modifications to the steering wheel could affect the functionality or performance of the system. Failure to follow this instruction could result in the loss of control of your vehicle, personal injury or death.

Adaptive cruise control precautions apply to lane centering unless stated otherwise or contradicted by a lane centering precaution. See **Adaptive Cruise Control Precautions** (page 255).

LANE CENTERING REQUIREMENTS

You must keep your hands on the steering wheel at all times.

Adaptive Cruise Control

Lane centering only activates when all of the following occur:

- Adaptive cruise control with lane centering is enabled in the touchscreen. See **Switching Lane Centering On and Off** (page 264).
- You have adaptive cruise control with stop and go enabled and set.
- The steering system detects your hands on the steering wheel.
- The system detects both lane markings when driving on a straight road.
- Your vehicle is initially centered in the lane between two visible line markings.
- A trailer is not detected.

Note: *If the system does not detect valid lane line markings, the system remains in standby until valid line markings are available.*

Note: *If the system does not detect your hands on the steering wheel, apply a slight force to the steering wheel.*

LANE CENTERING LIMITATIONS

Adaptive cruise control limitations apply to lane centering unless stated otherwise or contradicted by a lane centering limitation. See **Lane Centering Requirements** (page 263).

Lane Centering may not be able to center your vehicle in the lane in any of the following conditions:

- The lane is too narrow or wide.
- The curve in the road is too tight.
- The system does not detect the minimum required lane markings or when lanes merge or split.
- When the required steering effort to maintain lane center exceeds the lane centering system limit.
- When driving in areas that are under construction or when road work is in progress.
- If the front windshield camera and/or the front radar are blocked.
- When using a spare tire.
- Inclement weather conditions including, but not limited to, high wind, heavy rain, and fog.
- Driving into direct sunlight.

- When modification to the steering system has been made, including alterations to the steering wheel.
- When a trailer is detected, the system disables lane centering. See **Lane Centering Precautions** (page 263).

Note: *The system steering assistance is limited and may not have sufficient effort for all driving situations and/or conditions, such as driving through tight curves or driving through curves at high speeds.*

Note: *In exceptional conditions, the system may deviate from the lane center.*

SWITCHING LANE CENTERING ON AND OFF

You must keep your hands on the steering wheel at all times.

The controls are on the steering wheel.



Press the button.

The indicator appears in the instrument cluster. When the lane centering system is on, the color of the indicator changes to indicate the system status.

Adaptive Cruise Control

You can override the system at any time by steering your vehicle.

Note: *The lane centering requirements must be met before you can enable the feature. See **Lane Centering Requirements** (page 263).*

Enabling and Disabling Lane Centering

1. From the settings menu, press Driver Assistance.
2. Press Cruise Control.
3. Press Adaptive Cruise Control.
4. Switch Lane Centering on or off.

LANE CENTERING ALERTS

You must keep your hands on the steering wheel at all times.

When the system is active and detects no steering activity for a period of time, the system alerts you to put your hands on the steering wheel. If you do not react to the warnings the system quickly applies and releases the brakes, activates the hazard lights, and slows your vehicle to a stop within the lane of travel while maintaining steering control. See **Lane Centering Automatic Cancellation** (page 265).

The system also alerts you if your vehicle crosses lane markings without detected steering activity.

Note: *The system could detect a light grip or touch on the steering wheel as hands-off driving.*

LANE CENTERING AUTOMATIC CANCELLATION

When an external condition cancels the system, for example, no lane markings available, an audible warning sounds and a message appears in the instrument cluster display.

When an external condition cancels the system, and your hands are not on the steering wheel, the system immediately alerts you to take control of the vehicle.

If this alert is ignored, the system quickly applies and releases the brakes, activates the hazard lights, and slows your vehicle to a stop within the lane of travel.

If your vehicle slows down or stops and you resume control, a message appears to prompt you to press the accelerator pedal to allow the system to resume.

Note: *If the system detects significant inactivity, a 'Lane Centering Unavailable' message displays in the instrument cluster and lane centering is disabled until the next time you start your vehicle.*

Automatic cancellation can also occur if:

- The lane becomes too wide or too narrow.
- The system cannot detect valid lane markings.
- Lane markings cross over one another.
- The curve of the road is too sharp.

LANE CENTERING MANUAL CANCELLATION

When you perform the following actions, adaptive cruise control with lane centering will cancel:

- The brake pedal is pressed.
- Adaptive cruise control button on the steering wheel is switched off.

The lane centering system is momentarily suppressed when either of the following actions are performed:

- Turn signal indicator is latched or tapped.
- You steer the vehicle out of lane.

Adaptive Cruise Control

LANE CENTERING INDICATORS



Illuminates when you switch lane centering on. The color of the indicator changes to indicate the system status.

Gray status indicates the system is on but in standby mode.

Green status indicates the system is enabled and applying steering assistance to keep the vehicle in the center of the lane.

Amber status with an audible tone, that then changes to gray status, indicates a system automatic cancellation.

LANE CENTERING – TROUBLESHOOTING

LANE CENTERING – INFORMATION MESSAGES

Note: Depending on your vehicle options and instrument cluster type, some messages can appear different or not at all.

Message	Details
Keep Hands on Steering Wheel	You must return your hands to the steering wheel and provide steering input to cancel the message.
Lane Centering Assist Not Available	Lane centering is currently not available, due to conditions that prevent the system from becoming active. To reset the system, when the vehicle is stationary, return the gear selector to park (P) and turn the vehicle off. Then, restart the vehicle with your foot on the brake pedal.
Resume Control	Adaptive cruise control with lane centering is about to cancel. You must immediately take full control of the vehicle.
Press Accelerator Pedal to Resume	Adaptive cruise control with lane centering is in standby mode. When safe to do so, you can resume adaptive cruise control with lane centering by applying pressure on the accelerator pedal. Alternatively, you can also re-enable adaptive cruise control with lane centering by pressing the resume button on the steering wheel.

Adaptive Cruise Control

PREDICTIVE SPEED ASSIST (IF EQUIPPED)

HOW DOES PREDICTIVE SPEED ASSIST WORK

Predictive Speed Assist works with adaptive cruise control and adjusts the vehicle speed to the road geometry and to the speed limit detected by the speed sign recognition system. As the system identifies curves and highway exits, the vehicle speed temporarily decreases ahead of and during the changing road geometry. When passing new speed signs, the set speed updates. See **Predictive Speed Assist Precautions** (page 267).

There are limitations that affect the accuracy of the speed sign recognition system and its ability to determine the current speed limit. Predictive speed assist and its ability to determine the current speed limit shares these limitations. See **Speed Sign Recognition** (page 316).

Note: *The adaptive cruise control gap setting operates normally when the feature is enabled.*

PREDICTIVE SPEED ASSIST PRECAUTIONS



WARNING: You are responsible for controlling your vehicle at all times. The system is designed to be an aid and does not relieve you of your responsibility to drive with due care and attention. Failure to follow this instruction could result in the loss of control of your vehicle, personal injury or death.



WARNING: Pay close attention to changing road conditions. You may need to override the system by pressing the brake or accelerator pedal if the adjusted speed becomes higher or lower than necessary.



WARNING: The system only provides limited braking. Your vehicle may not always decelerate quickly enough to avoid a crash without driver intervention. Apply the brakes when necessary.



WARNING: The system does not activate the turn signal.

Adaptive cruise control precautions apply to predictive speed assist unless stated otherwise or contradicted by a predictive speed assist precaution. See **Adaptive Cruise Control Precautions** (page 255).

The system only applies limited braking. You can override the system with the accelerator pedal or cancel the system by applying the brakes.

The system may adapt to various factors such as time of day, lane width. This could influence speed adjustments and accelerations.

The system may adapt to various drive modes. See **Drive Mode Control** (page 280). This could influence speed adjustments and accelerations.

Note: *The system does not activate the turn signal automatically.*

Adaptive Cruise Control

PREDICTIVE SPEED ASSIST LIMITATIONS



WARNING: The system may not always adjust vehicle speed in certain road or weather conditions such as crossing traffic, yield or stop signs, right of way, traffic lights, speed bumps, rain, snow, fog. You must always apply the brake or accelerator pedal when necessary.

The road geometry and speed limit information provided by the navigation map data could be inaccurate or out of date.

The system may not detect and read speed limit signs with conditional information, for example, when a sign is flashing, during specific time ranges, or when children are present.

Note: *The system does not set the vehicle speed to speed limits shown with a supplementary traffic sign.*

Under certain conditions, the system may not adjust the vehicle speed until after your vehicle passes the speed limit.

Detection of road geometry operates only where related information is available. Road geometry information may not be available in some areas.

SWITCHING PREDICTIVE SPEED ASSIST MODE ON AND OFF

1. From the settings menu, press Driver Assistance.
2. Press Cruise Control.
3. Press Adaptive Cruise Control.
4. Switch Predictive Speed Assist on or off.

ADJUSTING THE SET SPEED TOLERANCE

1. From the settings menu, press Driver Assistance.
2. Press Cruise Control.
3. Press Adaptive Cruise Control.
4. Switch Predictive Speed Assist on.
5. Press Tolerance.
6. Adjust the slider to set the tolerance.

Note: *You can set tolerance for vehicle speed adjustment based on speed sign recognition only.*

PREDICTIVE SPEED ASSIST ALERTS

If the speed sign recognition system detects a speed limit below the minimum adaptive cruise control set speed, a tone sounds and the system returns to standby mode.

PREDICTIVE SPEED ASSIST INDICATORS

A blue marker around the speed sign and a blue arrow next to the set speed indicates that the system is active.

Speed sign indicator

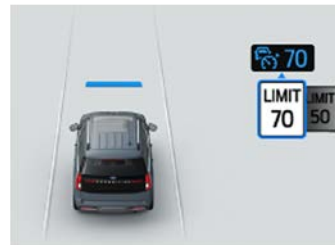

Adaptive Cruise Control

When the system detects a new speed sign, a gray indicator appears above the set speed while the system adjusts the vehicle speed to the speed limit. When the speed limit is reached, the set speed updates and the gray indicator disappears.

Road geometry indicator

When the system detects a curve or highway exit, the vehicle starts to decelerate, and the indicator appears and changes color.

Road geometry indicator symbols



Left curve.



Right curve.

PREDICTIVE SPEED ASSIST – TROUBLESHOOTING

PREDICTIVE SPEED ASSIST – INFORMATION MESSAGES

Message	Details
Adaptive Cruise Control Speed Sign Recognition Not Available	Navigation system based speed limit information is not available. If the message continues to appear, have your vehicle checked as soon as possible.
Driver Resume Control	The system is going to cancel and you must take control.

Adaptive Cruise Control

ADAPTIVE CRUISE CONTROL – TROUBLESHOOTING

ADAPTIVE CRUISE CONTROL – INFORMATION MESSAGES

Note: The system could abbreviate or shorten certain messages depending upon which cluster type you have.

Note: Depending on your vehicle options and instrument cluster type, not all messages display or are available.

Message	Details
Front Sensor Not Aligned	Contact an authorized dealer to have the radar checked for proper coverage and operation.
Cruise Control Not Available	Conditions exist preventing the system from being available.
Adaptive Cruise Control Not Available Sensor Blocked See Manual	You have a blocked radar because of poor radar visibility due to inclement weather or ice, mud, or water in front of the sensor. You can typically clean the sensor to resolve this issue. Due to the nature of sensor technology, it is possible to get a blockage warning with no actual block. This happens, for example, when driving in sparse rural or desert environments. A false blocked condition either self clears, or clears after you restart your vehicle.
Normal Cruise Active Adaptive Braking Off	You have selected normal cruise control. The system does not brake or react to traffic.
Adaptive Cruise - Driver Resume Control	Displays when the adaptive cruise control is going to cancel and you must take control.
Cruise Control Speed Too Low to Activate	Displays when the vehicle speed is too slow to activate the adaptive cruise control and there is no lead vehicle in range.

BlueCruise (If Equipped)

WHAT IS BLUECRUISE

BlueCruise keeps your vehicle centered in the lane and offers a hands-free driving mode in certain situations when using adaptive cruise control.

HOW DOES BLUECRUISE WORK

BlueCruise uses cameras to monitor your vehicle position within a lane and applies steering support to keep your vehicle centered in the lane.

Using the cameras and location information, BlueCruise allows you to remove your hands from the steering wheel and offers a hands-free driving mode in certain areas.

When active, BlueCruise uses a driver facing camera and infrared lighting to monitor your eyes and head position to detect if you are distracted. If the system determines you are distracted, it alerts you to return your eyes to the road.

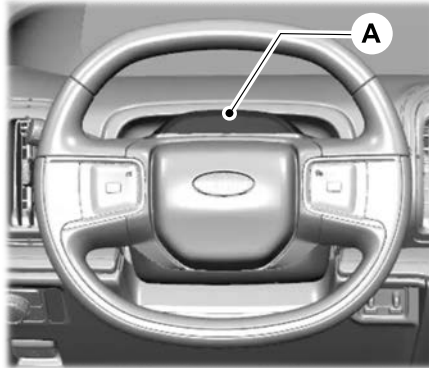

A Lighting area and camera.

Note: *When BlueCruise is active, in certain crash or near crash-like situations, such as an air bag deployment or hitting a road obstacle, camera data may record through the vehicle event data recorder. See **Event Data** (page 25).*

Note: *No data records under normal driving conditions.*

BLUECRUISE PRECAUTIONS

WARNING: You are responsible for keeping your eyes on the road at all times. The system is designed to be an aid and does not relieve you of your responsibility to drive with due care and attention. Failure to follow this instruction could result in the loss of control of your vehicle, personal injury or death.

WARNING: You are responsible for controlling your vehicle at all times. The system is designed to be an aid and does not relieve you of your responsibility to drive with due care and attention. Failure to follow this instruction could result in the loss of control of your vehicle, personal injury or death.

WARNING: Do not use the system when towing a trailer. Failure to follow this instruction could result in the loss of control of your vehicle, personal injury or death.

BlueCruise (If Equipped)

 **WARNING:** Obstructions to the driver facing camera or infrared lighting could prevent the system from properly operating. Keep the camera and lighting areas free from obstruction. Failure to follow this instruction could result in the loss of control of your vehicle, personal injury or death.

 **WARNING:** Do not use the system if any changes or modifications to the steering wheel have been made. Any changes or modifications to the steering wheel could affect the functionality or performance of the system. Failure to follow this instruction could result in the loss of control of your vehicle, personal injury or death.

 **WARNING:** The system may not function if the sensor is blocked.

 **WARNING:** Pay close attention to changing road conditions such as entering or leaving a highway, on roads with intersections or roundabouts, roads without visible lanes of travel, roads that are unpaved, or steep slopes, railroad crossings, pedestrian crossings, and school zones. Failure to follow this instruction could result in the loss of control of your vehicle, personal injury or death.

 **WARNING:** The system is not a crash warning or avoidance system.

 **WARNING:** Large contrasts in outside lighting can limit sensor performance.

 **WARNING:** The system attempts to keep your vehicle in the center of the lane as well as maintain speed and gap control. The system may not be able to perform these tasks in all situations. Do not use the system in complex or uncertain driving conditions. Failure to follow this instruction could result in the loss of control of your vehicle, personal injury or death.

 **WARNING:** Your vehicle could drift out of the lane of travel. Always be prepared to manually steer your vehicle. Failure to follow this instruction could result in the loss of control of your vehicle, personal injury or death.

 **WARNING:** The system will not operate if the sensor cannot track the road lane markings.

BLUECRUISE REQUIREMENTS

BlueCruise only activates when all of the following occur:

- BlueCruise service plan is active. See Ford.com (<https://www.ford.com/connectedservices/>) or the Ford mobile app for details.
- Modem is enabled. See **Connecting the Vehicle to a Mobile Network** (page 458).
- BlueCruise is enabled in your center display screen. See **BlueCruise Settings** (page 273).
- Adaptive cruise control is switched on.

BlueCruise (If Equipped)

- Automatic Emergency Braking is switched on. See **Switching Automatic Emergency Braking On and Off** (page 313).
- The driver seatbelt is fastened.
- The system detects both lane markings.
- Your hands are on the steering wheel.
- Your eyes are on the road.

Note: For hands-free mode to work, your vehicle must be on certain limited access divided freeways.

Note: The system may require updated software for hands-free mode. See **Vehicle Software Updates** (page 483).

Note: Without an active BlueCruise subscription, your vehicle is still capable of lane centering. This system requires you to keep your hands on the steering wheel at all times. See **Lane Centering Requirements** (page 263).

BLUECRUISE LIMITATIONS

Any of the following conditions could result in BlueCruise not correctly operating:

- You do not have your vehicle centered in the lane.
- The lane is too narrow or too wide.

- The system does not detect at least one lane marking or when lanes merge or split.
- You are applying a low amount of steering input.
- You are using the system in areas under construction.
- If you make any aftermarket modifications to the steering system.
- You are using a spare tire.

The driver-facing camera may not operate correctly due to any of the following:

- You have visual impairment, such as an eye misalignment, or have had eye surgery.
- You cover your facial features by a mask, hat or other items.
- The lighting conditions significantly change.
- You are not in the camera's field of view.
- You position or tilt yourself to one side.
- You are moving around extensively.
- You are wearing glasses or sunglasses that are too dark or reflective.

Note: The system has limited steering assistance and may not be sufficient for all driving situations.

Note: In exceptional conditions, such as inclement weather or direct sunlight, the system could deviate from the center line.

Note: The information provided by the navigation map data could be inaccurate or out of date.

BLUECRUISE SETTINGS

Enabling BlueCruise

1. From the settings menu, press Driver Assistance.
2. Press Adaptive Cruise Control.
3. Press Lane Centering with Hands-Free.

Enabling Activation Prompts

1. From the settings menu, press Driver Assistance.
2. Press Adaptive Cruise Control.
3. Press Activation Prompts.

SWITCHING BLUECRUISE ON AND OFF

Switching BlueCruise On

The controls are on the steering wheel.

BlueCruise (If Equipped)

Using Activation Prompts



When the prompt appears, press the button to switch BlueCruise on.

The indicator appears in the instrument cluster. When the system is on, the indicator color changes to indicate the system status.

Note: *You must enable activation prompts in the touchscreen.*

Using Steering Wheel Controls



Press the adaptive cruise control button to activate BlueCruise.

Switching BlueCruise Off



Press the adaptive cruise control button when the system is active or in standby mode.

BlueCruise turns off through each ignition cycle.

BLUECRUISE ALERTS

When BlueCruise is providing hands-on driving or transitioning to hands-on driving from hands-free driving and detects no steering activity for a certain period of time, the system alerts you with an audible warning and a message in the instrument cluster display to put your hands on the steering wheel.

When BlueCruise is providing hands-on or hands-free driving and detects you are not looking at the road for a certain period of time, the system alerts you to return your eyes to the road. Depending on where you are looking, the alert can be a message in the instrument cluster and an audible warning.

If you do not react to the warnings, the system alerts you to take control of your vehicle, quickly applies and releases the brakes, activates the hazard lights, and slows your vehicle to a stop within the lane of travel while maintaining steering control.

If your vehicle slows down or stops and you resume control, a message appears to prompt you to press the accelerator pedal to allow the system to resume.

Note: *If the system detects significant inactivity, it disables until the next time you start your vehicle.*

BLUECRUISE AUTOMATIC CANCELLATION

When an external condition cancels BlueCruise, for example, no lane markings available, a message appears in the instrument cluster, and an audible warning sounds.

RES

If your vehicle starts to slow down, you must take control by returning your attention to the road and your hands to the steering wheel. Then press and release the button to reactivate BlueCruise.

System cancellation can also occur if:

- The lane becomes too narrow.
- The system cannot detect valid lane markings.
- Lane markings cross.
- Your eyes are not on the road or your hands are not on the steering wheel.

If you have your hands on the steering wheel and your eyes are on the road when the feature is active and a cancellation occurs, the system displays a canceled graphic in the instrument cluster and sounds an audible warning.

BlueCruise (If Equipped)

If you are not paying attention to the road or your hands are not on the steering wheel and a cancellation occurs, the system displays a message in the instrument cluster, and sounds an audible warning until you resume control.

If you do not resume control in time, BlueCruise quickly activates and releases the brakes, activates the hazard lights, and slows your vehicle to a stop within the lane of travel while maintaining steering control.

If your vehicle slows down or stops and you resume control, a message appears to prompt you to press the accelerator pedal to allow the system to resume.

Note: *If the system detects repeated inactivity, it disables until the next time you start your vehicle.*

BLUECRUISE INDICATORS



When on, the color of the indicator changes to indicate the status.

Gray indicates BlueCruise is on but inactive.

Green indicates BlueCruise is active and applying continuous steering support.

Blue indicates BlueCruise is active and hands-free driving mode is available.

Hands-On Driving Support Available



When this indicator is present, you must keep your hands on the steering wheel.

Hands-Free Driving Support Available

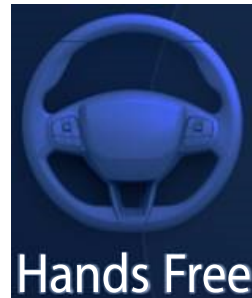

A graphic in the instrument cluster of a steering wheel without hands indicates the hands-free driving mode is available.

When this indicator is present, you can remove your hands from the steering wheel.

BlueCruise (If Equipped)

LANE CHANGE ASSIST

HOW DOES LANE CHANGE ASSIST WORK



Lane change assist can automatically perform a single lane change when you request the lane change using the turn signal lever. This feature is available down to 40 mph (65 km/h).

WARNING: You are responsible for controlling your vehicle at all times. The system is designed to be an aid and does not relieve you of your responsibility to drive with due care and attention. Failure to follow this instruction could result in the loss of control of your vehicle, personal injury or death.

WARNING: Do not use the lane change assist system as a replacement for using the interior and exterior mirrors or looking over your shoulder before changing lanes. The lane change assist system is not a replacement for careful driving.

1. Make sure the lane you are requesting is clear of traffic or obstacles.
2. Tap or latch the lever in the direction of your planned lane change.
3. Once the lane change is complete, move the turn signal lever back to the middle position if necessary.

Note: When using lane change assist you can tap or latch the lever.

Lane Change Suggestion

If you are approaching or have been following a slower moving vehicle, the system may suggest a lane change to pass that vehicle using an available passing lane.

LANE CHANGE ASSIST LIMITATIONS

Lane change assist will not perform the requested maneuver if traffic is identified in the selected lane.

SWITCHING LANE CHANGE ASSIST ON AND OFF

1. From the settings menu, press Driver Assistance.
2. Press Cruise Control.
3. Press Lane Change Assist to toggle the system on and off.

LANE CHANGE ASSIST CANCELLATION

To cancel lane change assist, manually steer your vehicle or return the turn signal lever to the middle position.

BlueCruise (If Equipped)

LANE CHANGE ASSIST – TROUBLESHOOTING

LANE CHANGE ASSIST – INFORMATION MESSAGES

Message	Details
Lane busy	The lane you have selected to enter has a vehicle or obstacle.
No lane seen	A lane is not recognized or available to perform the requested maneuver.
Changing lanes	The requested lane change is being performed.
Lane change possible	If desired, press the turn signal lever in the direction indicated by the lane change suggestion to initiate the lane change.

Note: *The instrument cluster display may abbreviate or shorten certain messages.*

IN-LANE REPOSITIONING

HOW DOES IN-LANE REPOSITIONING WORK

BlueCruise with in-lane repositioning uses the vehicle's front and corner radar sensors together with the front windshield camera sensor to operate.

Using these sensors, the system automatically adjusts your vehicle's position in the lane based on the current driving situation.

Note: *In-lane repositioning is active only when BlueCruise is enabled while traveling on divided highways and when any of the following occur:*

- Passing or being passed by adjacent lane vehicles in close proximity.
- In a curve.
- Driving in outer lanes.

Note: *In certain situations, the vehicle may bias without showing the indicators.*

Note: *Keep the front of your vehicle free of dirt, metal badges or objects. Vehicle front protectors, aftermarket lights, additional paint or plastic coatings could also degrade sensor performance.*

Note: *The radar sensor has a limited field of view. It may not detect vehicles at all or detect a vehicle later than expected in some situations.*

BlueCruise (If Equipped)

SWITCHING IN-LANE REPOSITIONING ON AND OFF

1. From the settings menu, press Driver Assistance.
2. Press Cruise Control.
3. Press Adaptive Cruise Control.
4. Press Lane Centering.
5. Press In-Lane Repositioning to toggle the system on or off.

IN-LANE REPOSITIONING INDICATORS



Biased towards right-hand side of the lane.



Biased towards left-hand side of the lane.

BLUECRUISE – TROUBLESHOOTING

BLUECRUISE – INFORMATION MESSAGES

Depending on your vehicle options and instrument cluster type, not all messages display or are available.

BlueCruise (If Equipped)

Message	Details
Keep Hands on Steering Wheel	Make sure you return your hands to the steering wheel and provide steering input.
Resume Control	The system is going to cancel and you must take control by returning your attention to the road and your hands to the steering wheel.
Watch the Road	Return your attention to the road.
BlueCruise not available	Conditions exist preventing the system from being available. If the message continues to display, have the system checked as soon as possible.
Press Accelerator Pedal to Resume	Press the accelerator pedal and follow the prompts.
Driver monitor camera cannot detect face See manual	Make sure your facial features are visible and in the field of view of the driver facing camera.
Driver monitor camera is blocked See manual	Make sure your hands, arms or other objects are not obscuring the camera.
Driver monitor camera fault See manual	Conditions exist preventing the system from being available. If the message continues to display, have the system checked as soon as possible.
BlueCruise On Watch the road Be prepared to resume control	BlueCruise is active, keep your attention on the road.
BlueCruise available Press {ICON} to activate	The system is in standby mode, press the button on the steering wheel to activate.

Note: *The instrument cluster display may abbreviate or shorten certain messages.*

Drive Mode Control

WHAT IS DRIVE MODE CONTROL

This feature connects multiple vehicle systems through a single interface, providing you with enhanced vehicle control and driving dynamics for different driving scenarios, terrains, weather, or various road conditions.

HOW DOES DRIVE MODE CONTROL WORK

When a drive mode is selected it alters various electrical and mechanical systems within the vehicle to a predetermined configuration. The systems altered and features available will depend on which mode is selected.

Note: : The electronic locking differential is available and automatically engages in some drive modes. See **Electronic Locking Differential** (page 209).

Note: Your vehicle reverts to normal mode each time you start it. If you shut your vehicle off in a drive mode other than normal mode, at startup the instrument cluster screen displays a pop-up asking if you would like to return to your last used drive mode. If you select yes to the pop up, your vehicle returns to the last selected drive mode and driveline state. If you select no, your vehicle reverts the driveline to last used state. If you do not select yes or no, the pop-up message times out, your vehicle remains in normal mode, and the four-wheel driveline setting remains in its last used setting.

SELECTING A DRIVE MODE - 4X2

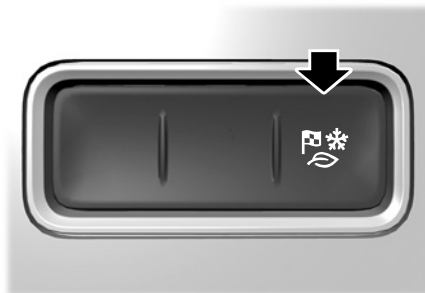

Press the drive mode button located on the center console to open the drive mode menu on the center display. Select a drive mode from the menu on the center display. Subsequent presses of the drive mode button deactivates the drive mode selection menu on the center display.

Note: Drive mode changes may not be available when the ignition is off.

SELECTING A DRIVE MODE - 4X4



Drive Mode Control

Rotate the controller located on the instrument panel. Rotate the drive mode controller once to activate the drive mode selection menu in the display. Rotate the controller a second time to select and engage the drive mode.

Note: *Button icons vary depending on the vehicle's configuration.*

DRIVE MODES

ECO - 4X2



This mode decreases accelerator pedal responsiveness to soften driver inputs and encourage efficient driving. Depending on your vehicle's options, adaptive cruise control is slower to return to the set speed and auto start-stop engages more often. The system decreases air conditioning output to conserve energy when set to auto mode. Use this mode for fuel efficient driving which allows for an extended vehicle range.

ECO - 4X4



This mode decreases accelerator pedal responsiveness to soften driver inputs and encourage efficient driving. Depending on your vehicle's options, adaptive cruise control is slower to return to the set speed and auto start-stop engages more often. The system decreases the air conditioning output to conserve energy when set to Auto Mode.

Use this mode for fuel efficient driving which allows for an extended driving range.

Note: *The electronic locking differential is available below 25 mph (40 km/h). See **Switching the Electronic Locking Differential On and Off** (page 209).*

NORMAL - 4X2



This mode adjusts all systems to their base settings and balances vehicle performance for all around drivability. Each time you switch your vehicle off it defaults to this mode. Use this mode for everyday driving, such as city and highway routes or commuting.

NORMAL - 4X4



This mode adjusts all systems to their base settings and balances vehicle performance for all around drivability. Each time you switch your vehicle off it defaults to this mode.

Use this mode for everyday driving, such as city and highway routes or commuting.

Note: *All four-wheel drive modes are selectable when in normal mode.*

Note: *The electronic locking differential is available below 25 mph (40 km/h). See **Switching the Electronic Locking Differential On and Off** (page 209).*

OFF-ROAD - 4X4



This mode lowers accelerator pedal responsiveness and delays transmission upshifts for improved vehicle control in low speed off-road environments. Traction and stability controls allow the wheels to spin to maintain vehicle momentum and clear debris from the tires for improved traction.

Depending on your vehicle's options, the system inhibits auto start stop and engages the rear electronic locking differential.

Drive Mode Control

Use this mode for driving through mud, sand, and rough, uneven off-road terrains.

Note: *Four-wheel drive high (4H) is the default four-wheel drive mode. Depending on your vehicle options, four-wheel drive auto (4A) or two-wheel drive high (2H) is not available.*

Note: *The electronic locking differential engages when you select this mode at any speed, and you can disengage it at any time using the button. See **Switching the Electronic Locking Differential On and Off** (page 209).*

Note: *This mode is for Off-Road use only. Do not use this mode when driving on pavement. Depending on the four-wheel drive mode selection, this could cause driveline bind up and damage the system. See **Four-Wheel Drive** (page 198).*

ROCK CRAWL



This mode lowers accelerator pedal responsiveness and holds the transmission in lower gears to enhance vehicle control for low speed rock crawling. The system switches the traction and stability controls to their rock crawl settings.

Use this mode when crossing aggressive terrain including rocks, mountain trails, and boulders.

Note: *Four-wheel drive low (4L) is the only four-wheel drive mode available.*

Note: *This mode is for Off-Road use only. Do not use this mode when driving on pavement. This could cause driveline bind up and damage the system depending on the four-wheel drive mode you select. See **Four-Wheel Drive** (page 198).*

SLIPPERY - 4X2



This mode lowers accelerator pedal responsiveness, adjusts transmission shift points, and optimizes traction and stability controls to help mitigate wheel spin and maintain vehicle control in slick driving conditions. Depending on your vehicle's options, this feature adjusts all-wheel drive control to provide optimum traction for slippery surfaces.

Use this mode for less than ideal road conditions such as snow and ice covered roads or for firm surfaces that are covered with loose or slippery materials.

Note: *Do not use this mode when driving on dry pavement.*

SLIPPERY - 4X4



This mode lowers accelerator pedal responsiveness, adjusts transmission shift points, and optimizes traction and stability controls to help mitigate wheel spin and maintain vehicle control in slick driving conditions. Depending on your vehicle's options, this feature adjusts all-wheel drive control to provide optimum traction for slippery surfaces.

Use this mode for less than ideal road conditions such as snow and ice covered roads or for firm surfaces that are covered with loose or slippery materials.

Note: *Do not use this mode when driving on dry pavement. This could cause driveline bind up and damage the system depending on the four-wheel drive mode selection. See **Four-Wheel Drive** (page 198).*

Note: *The electronic locking differential is available below 25 mph (40 km/h). See **Switching the Electronic Locking Differential On and Off** (page 209).*

Drive Mode Control

SPORT - 4X2



This mode increases accelerator pedal responsiveness and holds the transmission in lower gears longer for enhanced acceleration. The system switches the chassis controls to their sport settings. Depending on your vehicle's options, this feature sets the exhaust sound to a louder tone, inhibits auto-start stop, increases steering effort, and it adjusts the suspension for enhanced driver connectivity and responsive driving dynamics.

Use this mode for a sportier and engaging driving experience.

SPORT - 4X4



This mode increases accelerator pedal responsiveness and holds the transmission in lower gears longer for enhanced acceleration. The system switches the chassis controls to their sport settings. Depending on your vehicle's options, this feature sets the exhaust to a louder tone, inhibits auto-start stop, increases steering torque buildup, and it adjusts the suspension for enhanced driver connectivity and responsive driving dynamics.

Use this mode for a sportier and engaging driving experience.

Note: *The electronic locking differential is available below 25 mph (40 km/h). See **Switching the Electronic Locking Differential On and Off** (page 209).*

TOW/HAUL - 4X2



For improved vehicle operation when towing a trailer or hauling a heavy load. This mode moves upshifts to higher engine speeds to reduce the frequency of transmission shifting. It also provides downshift engine braking to assist in maintaining vehicle speed when descending a slope. Depending on your vehicle's options, the system enhances steering response to assist in controlling the vehicle when towing or hauling and auto-start stop is inhibited.

TOW/HAUL - 4X4



For improved vehicle operation when towing a trailer or hauling a heavy load. This mode moves upshifts to higher engine speeds to reduce the frequency of transmission shifting. It also provides downshift engine braking to assist

in maintaining vehicle speed when descending a slope. Depending on your vehicle's options, the system enhances steering response to assist in controlling the vehicle when towing or hauling and auto-start stop is inhibited.

Note: *The electronic locking differential is available below 25 mph (40 km/h). See **Switching the Electronic Locking Differential On and Off** (page 209).*

DRIVE MODE CONTROL – TROUBLESHOOTING

DRIVE MODE CONTROL – WARNING LAMPS



Some drive modes reduce traction and stability control performance and the indicator illuminates in the instrument cluster.

Note: *The system has diagnostic checks that continuously monitor the system for proper operation. If a mode is unavailable due to a system fault, the drive mode system defaults to normal. When the system defaults to normal, the driveline settings remain the same as prior to the system fault.*

Drive Mode Control

DRIVE MODE CONTROL – INFORMATION MESSAGES

Message	Details
Drive Mode Not Available	The drive mode selection is temporarily unavailable. The default drive mode is active.

Drive Mode Control

DRIVE MODE CONTROL – FREQUENTLY ASKED QUESTIONS

Why did the system default to normal mode?

- If a mode is unavailable due to a system fault, it defaults to normal mode and the driveline settings remain the same as prior to the system fault.

Can I switch drive modes while I am driving?

- In most instances, you can switch drive modes while you are driving (if you maintain attention on the road), or while the vehicle is stationary. However, you should not switch the vehicle into a drive mode intended for off-road or track use while driving on paved, public roads. For example, while driving on a paved highway, it would be acceptable to switch from normal mode to eco mode, but not to off-road mode.

How long does it take for the vehicle to switch modes after I make a selection?

- After switching modes, the new drive mode will activate within several seconds, if all the appropriate pre-conditions are met.

How should I decide which drive mode to use?

- Selecting a drive mode usually depends on the driving experience you would like to have, and the driving conditions. For example, if you want to have a more exciting on-road driving experience, you could switch into sport mode. If you find yourself driving on slick roads, you could switch into slippery mode.

Will drive modes impact my vehicle's fuel consumption?

- Drive modes can have an impact on your vehicle's fuel consumption. In addition to the active mode, your driving style will also affect the fuel consumption.

Lane Keeping System

WHAT IS THE LANE KEEPING SYSTEM

The lane keeping system alerts you by providing temporary steering assistance or steering wheel vibration when it detects an unintended lane departure.

HOW DOES THE LANE KEEPING SYSTEM WORK

The lane keeping system uses a forward looking camera mounted on the windshield to monitor vehicle movement within the lane of travel.

When the camera detects a drift out of the lane of travel, the lane keeping system alerts the driver by vibrating the steering wheel, or aids the driver by providing a small steering input to move the vehicle back into the lane of travel.

The driver can select one of three modes:

- Alert (if equipped)
- Aid
- Alert + Aid

LANE KEEPING SYSTEM PRECAUTIONS

 **WARNING:** You are responsible for controlling your vehicle at all times. The system is designed to be an aid and does not relieve you of your responsibility to drive with due care and attention. Failure to follow this instruction could result in the loss of control of your vehicle, personal injury or death.

 **WARNING:** The system will not operate if the sensor cannot track the road lane markings.

 **WARNING:** The sensor may incorrectly track lane markings as other structures or objects. This can result in a false or missed warning.

 **WARNING:** In cold and severe weather conditions the system may not function. Rain, snow and spray can all limit sensor performance.

 **WARNING:** The system may not operate properly if the sensor is blocked. Keep the windshield free from obstruction.

 **WARNING:** If damage occurs in the immediate area surrounding the sensor, have your vehicle checked as soon as possible.

 **WARNING:** The system may not correctly operate if your vehicle is fitted with a suspension kit not approved by us.

 **WARNING:** Large contrasts in outside lighting can limit sensor performance.

LANE KEEPING SYSTEM LIMITATIONS

The lane keeping system only operates when the vehicle speed is greater than 40 mph (64 km/h).

The system works when the camera can detect at least one lane marking or the edge of the road.

Note: When you select Aid or Alert and Aid mode and the system detects no steering activity for a short period of time, the system alerts you to put your hands on the steering wheel. The system may detect a light grip or touch on the steering wheel as hands-off driving.

Lane Keeping System

The lane keeping system may not correctly operate in any of the following conditions:

- The lane keeping system does not detect at least one lane marking or the edge of the road.
- You switch the turn signal on.
- You apply direct steering, accelerate fast or brake hard.
- The vehicle speed is less than 40 mph (64 km/h).
- The anti-lock brake, stability control or traction control system activates.
- The lane is too narrow.
- Something is obscuring the camera or it is unable to detect the lane markings due to environment, traffic or vehicle conditions.
- Entering or exiting a tight curve when driving at high speeds.

The lane keeping system may not correct lane positioning in any of the following conditions:

- High winds.
- Uneven road surfaces.
- Heavy or uneven loads.
- Incorrect tire pressure.

SWITCHING THE LANE KEEPING SYSTEM ON AND OFF



Switch the system on and off by accessing the lane keeping system icon through the multi-function button on your steering wheel.

To deactivate the lane keeping system, press the button again.

Note: When switching the system on or off a message appears in the instrument cluster display to show the status.

Note: The system stores the on or off setting until manually changed by you.

SWITCHING THE LANE KEEPING SYSTEM MODE

1. From the settings menu, press Driver Assistance.
2. Press Lane-Keeping System.
3. Press Lane-Keeping Mode.
4. Select a mode.

Note: The system remembers the last setting when you start your vehicle.

LANE KEEPING SYSTEM SETTINGS

Adjusting the Steering Wheel Vibration Intensity

1. From the settings menu, press Driver Assistance.
2. Press Lane Keeping System.
3. Press Lane Keeping Intensity.
4. Select a setting.

Note: This setting is not available in all modes.

Lane Keeping System

ALERT MODE

WHAT IS ALERT MODE

Alert mode vibrates the steering wheel when it detects an unintended lane departure.

HOW DOES ALERT MODE WORK

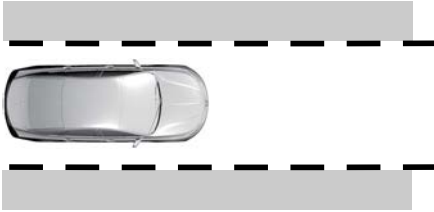

When in alert mode, the lane keeping system alerts you by vibrating the steering wheel. The intensity of the vibration is set through the lane keeping system menu.

AID MODE

WHAT IS AID MODE

Aid mode provides temporary steering assistance toward the center of the lane.

HOW DOES AID MODE WORK

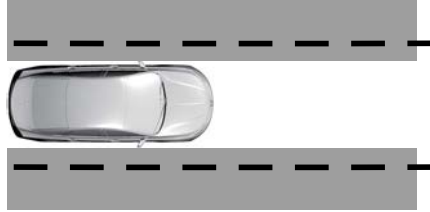

The lane keeping system aids you when an unintentional lane departure occurs. The system provides a small steering input to move the vehicle towards the center of the lane.

ALERT AND AID MODE

WHAT IS ALERT AND AID MODE

Alert and aid mode uses multiple features to keep you in your lane. The system first provides a small steering input to bring your vehicle back towards the center of the lane. If your vehicle moves too far from the center of the lane the system alerts you with vibration in the steering wheel.

Lane Keeping System

HOW DOES ALERT AND AID MODE WORK

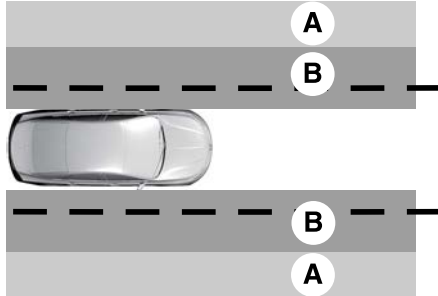

- A Alert.
- B Aid.

The lane keeping system detects a lane departure and provides aid when the vehicles enters **B** and applies the additional alert warning if **A** is entered.

LANE KEEPING SYSTEM INDICATORS



If you switch the lane keeping system on, a graphic with lane markings and an activation icon appear in the instrument cluster display.



If you switch the system off, the lane marking graphics do not display and a deactivation icon appears in the instrument cluster display.

Note: *The overhead vehicle graphic may still display if adaptive cruise control is enabled.*

While the lane keeping system is on, the color of the lane markings change to indicate the system status.

Gray	Green	Yellow	Red
Indicates that the system is temporarily unavailable to provide a warning or intervention on the indicated side.	Indicates that the system is available or ready to provide a warning or intervention on the indicated side.	Indicates that the system is providing or has just provided a lane keeping aid intervention.	Indicates that the system is providing or has just provided a lane keeping alert warning.

Lane Keeping System

BLIND SPOT ASSIST

WHAT IS BLIND SPOT ASSIST

Blind spot assist is an extension of the lane keeping system.

It may help you identify adjacent vehicles during a lane change.

Blind spot assist provides a blind spot warning and steering assistance to help you become aware of and steer away from vehicles in your blind spot during lane changes.

HOW DOES BLIND SPOT ASSIST WORK



Switch the system on and off by accessing the lane keeping system icon through the multi-function button on your steering wheel.

During lane changes, the design of the blind spot assist feature detects vehicles in, or approaching, your blind spot and provides a warning, plus steering assistance to direct your vehicle back into your lane.

When active, this system functions with or without the use of turn signals and hazard flashers.

You must keep your hands on the steering wheel at all times.

BLIND SPOT ASSIST LIMITATIONS

All system limitations present in the basic lane keeping system also apply to blind spot assist.

Blind spot assist does not function under the following conditions:

- No lane markings are detected.
- One or both rear radar sensors become blocked or faulty.
- Attaching bike or cargo racks could cause false alerts due to obstruction of the sensor.

Blind spot assist may have difficulty detecting hazards under the following conditions:

- If a vehicle is approaching in an adjacent lane at a speed higher than your vehicle.
- Bad weather obstructing the sensors.

BLIND SPOT ASSIST WITH TRAILER COVERAGE

WHAT IS BLIND SPOT ASSIST WITH TRAILER COVERAGE

Blind spot assist with trailer coverage is an extension of the lane keeping system.

It may help you identify adjacent vehicles during a lane change.

Blind spot assist provides a blind spot warning and steering assistance to help you become aware of and steer away from vehicles in your blind spot during lane changes.

When attaching a trailer, ensure you have properly set up the trailer coverage settings. See **Blind Spot Information System With Trailer Coverage** (page 297).

Lane Keeping System

HOW DOES BLIND SPOT ASSIST WITH TRAILER COVERAGE WORK



Switch the system on and off by accessing the lane keeping system icon through the multi-function button on your steering wheel.

During lane changes, the design of the blind spot assist feature detects vehicles in, or approaching, your blind spot and provides a warning, plus steering assistance to direct your vehicle back into your lane.

If a supported trailer is connected, the function is reduced to only detecting vehicles on both sides of your vehicle and trailer, extending rearward from the exterior mirrors to the end of your trailer. See **Blind Spot Information System With Trailer Coverage** (page 297).

When active, this system functions with or without the use of turn signals and hazard flashers.

You must keep your hands on the steering wheel at all times.

BLIND SPOT ASSIST WITH TRAILER COVERAGE LIMITATIONS

All system limitations present in the basic lane keeping system also apply to blind spot assist.

Blind spot assist does not function under the following conditions:

- No lane markings are detected.
- One or both rear radar sensors become blocked or faulty.
- You have not configured the attached trailer correctly in the trailer tow menus or you attached an unsupported trailer. The system only supports certain trailer shapes and dimensions.

Note: *Blind spot assist with trailer coverage could have reduced performance if any of the above limitations are present.*

Blind spot assist may have difficulty detecting hazards under the following conditions:

- If a vehicle is approaching in an adjacent lane at a relative speed much higher than your vehicle.
- Bad weather conditions are present that obstruct the sensors.
- Attaching bike or cargo racks could cause false alerts due to obstruction of the sensor.

Lane Keeping System

BLIND SPOT ASSIST WITH TRAILER COVERAGE INDICATORS

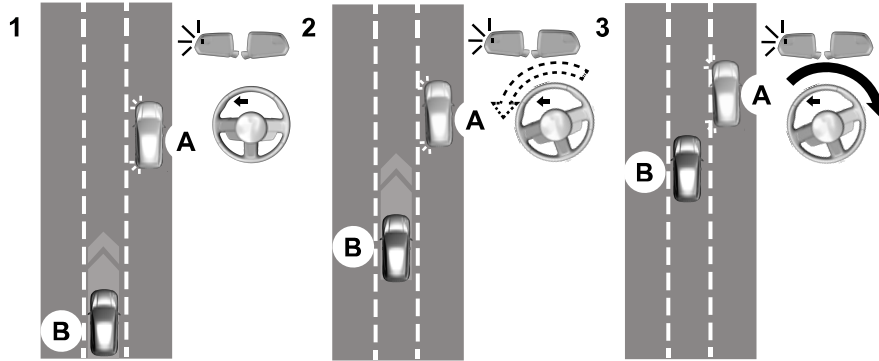

Diagram 1: Vehicle A uses its left turn signal preparing to change from the right lane to the middle lane. Vehicle B is already in the middle lane and just entered Vehicle A's blind spot causing the blind spot information system alert indicator to flash on the exterior mirror.

Diagram 2: The driver of Vehicle A begins to steer into the center lane not aware of Vehicle B.

Diagram 3: Blind spot assist counter steers to help alert the driver of Vehicle A to direct their vehicle back into the right lane to help avoid a possible collision with Vehicle B.

The lane keeping aid warning lamp or yellow lane marking in your instrument cluster display indicate blind spot assist activation. In addition, the blind spot information system alert indicator flashes on the exterior mirror on the same side as the detection. See **Blind Spot Information System** (page 296).

Lane Keeping System

Blind Spot Assist Information Messages

Message	Action
Blind Spot Assist Not Available Trailer Attached	Displays if you attach a trailer to your vehicle with the blind spot information system switched off or you have not configured the trailer.
Blind Spot Assist Not Available Side Sensor Blocked	Displays if your blind spot information system sensors are blocked.
Blind Spot Assist System fault	The system has detected a fault that requires service. Have your vehicle checked as soon as possible.
Trailer Brake Module Fault	Lost communication with the trailer module. Blind spot assist is disabled until the failure is fixed.
Trailer Lighting Module Fault See Manual	Lost communication with the trailer module. Blind spot assist is disabled until the failure is fixed.
Front Camera Fault Service Required	Front camera fault. Blind spot assist is disabled until the failure is fixed.

Lane Keeping System

LANE KEEPING SYSTEM – TROUBLESHOOTING

LANE KEEPING SYSTEM – INFORMATION MESSAGES

Message	Action
Lane Keeping Sys. Malfunction Service Required	The system has malfunctioned. Have your vehicle checked as soon as possible.
Front Camera Temporarily Not Available	The system has detected a condition that has caused the system to be temporarily unavailable.
Front Camera Low Visibility Clean Screen	The system has detected a condition that requires you to clean the windshield in order for it to operate properly.
Front Camera Malfunction Service Required	The system has malfunctioned. Have your vehicle checked as soon as possible.
Keep Hands on Steering Wheel	The system requests that you keep your hands on the steering wheel.

Lane Keeping System

LANE KEEPING SYSTEM – FREQUENTLY ASKED QUESTIONS

Why is the feature not available (lane markings are gray) when I can see the lane markings on the road?

- Your vehicle speed is less than 40 mph (65 km/h).
- The sun is shining directly into the camera lens.
- A quick intentional lane change has occurred.
- You are driving your vehicle too close to the lane markings for an extended interval of time.
- Driving at high speeds in curves.
- The last alert warning or aid intervention occurred a short time ago.
- Ambiguous lane markings, for example, in construction zones.
- Rapid transition from light to dark, or from dark to light.
- Sudden offset in lane markings.
- ABS or AdvanceTrac™ is active.

- There is a camera blockage due to dirt, grime, fog, frost or water on the windshield.
- You are driving too close to the vehicle in front of you.
- Transitioning between no lane markings to lane markings, or vice versa.
- There is standing water on the road.
- Faint lane markings, for example, partial yellow lane markings on concrete roads.
- Lane width is too narrow or too wide.
- You have not calibrated the camera after a windshield replacement.
- Driving on roads with tight curves or uneven surfaces.

Why does the vehicle not come back toward the middle of the lane, as expected, in the Aid, or Aid + Alert mode?

- High cross winds are present.
- There is a large road crown.
- Rough roads, grooves or shoulder drop-offs.
- Heavy, uneven loading of the vehicle or improper tire inflation pressure.

- You changed the tires or modified the suspension.

Blind Spot Information System

WHAT IS BLIND SPOT INFORMATION SYSTEM

Blind spot information system detects vehicles that may have entered the blind spot zone.

HOW DOES BLIND SPOT INFORMATION SYSTEM WORK

Blind spot information system uses sensors on both sides of your vehicle, detecting rearward from the exterior mirrors to approximately 13 ft (4 m) beyond the rear bumper. The detection area extends to approximately 59 ft (18 m) beyond the rear bumper when the vehicle speed is greater than 30 mph (48 km/h) to alert you of faster approaching vehicles.

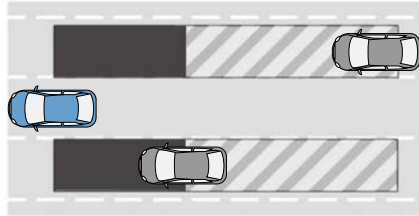

BLIND SPOT INFORMATION SYSTEM PRECAUTIONS

WARNING: Do not use the blind spot information system as a replacement for using the interior and exterior mirrors or looking over your shoulder before changing lanes. The blind spot information system is not a replacement for careful driving.

WARNING: The system may not operate properly during severe weather conditions, for example snow, ice, heavy rain and spray. Always drive with due care and attention. Failure to take care may result in a crash.

Note: Blind spot information system does not prevent contact with other vehicles. It does not detect parked vehicles, pedestrians, animals or other infrastructure.

BLIND SPOT INFORMATION SYSTEM LIMITATIONS

Blind spot information system does not operate in park (P) or reverse (R).

The system may not alert you if a vehicle quickly passes through the detection zone while overtaking.

Note: For vehicles without the trailer coverage feature, we recommend that you switch the blind spot information system off when you attach a trailer.

Blind Spot Information System

BLIND SPOT INFORMATION SYSTEM REQUIREMENTS

Blind spot information system turns on when all the following occur:

- You start your vehicle.
- You shift into drive (D).
- The vehicle speed is greater than 6 mph (10 km/h).

SWITCHING BLIND SPOT INFORMATION SYSTEM ON AND OFF

1. From the settings menu, press Driver Assistance.
2. Switch Blind Spot Information System on or off.

When you switch blind spot information system off, a warning lamp illuminates. When you switch the system on or off, the alert indicators flash twice. A telltale remains illuminated in the instrument cluster when the blind spot information system is switched off in the settings menu.

Note: The system remembers the last setting when you start your vehicle.

LOCATING THE BLIND SPOT INFORMATION SYSTEM SENSORS



The sensors are behind the rear fascia on both sides of your vehicle.

Note: Keep the sensors free from snow, ice and large accumulations of dirt.

Note: Do not cover the sensors with bumper stickers, repair compound or other objects.

Note: Bike and cargo racks could cause false alerts due to obstruction of the sensor. We recommend switching the feature off when using a bike or cargo rack.

Note: Blocked sensors may affect system accuracy.

If the sensors become blocked, a message appears in the instrument cluster display. See **Blind Spot Information System – Information Messages** (page 300). The alert indicators illuminate but the system does not alert you.

BLIND SPOT INFORMATION SYSTEM WITH TRAILER COVERAGE

WHAT IS BLIND SPOT INFORMATION SYSTEM WITH TRAILER COVERAGE

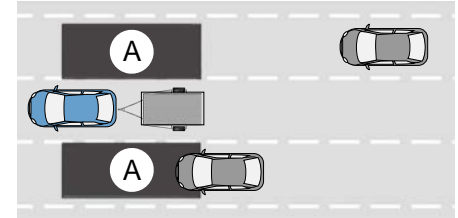

A. Trailer coverage detection zone.

Blind Spot Information System

Blind spot information system detects vehicles that may have entered the blind spot zone. The detection area is on both sides your vehicle and trailer, extending rearward from the exterior mirrors to the end of your trailer.

BLIND SPOT INFORMATION SYSTEM WITH TRAILER COVERAGE LIMITATIONS

Trailer coverage only supports conventional trailers.

Make sure the trailer width is less than or equal to 8.5 ft (2.6 m) and the length is less than 33 ft (10.1 m).

Some trailers could cause a slight change in system performance:

- Large box trailers, including v-nose or horse trailers, could cause false alerts to occur when driving next to infrastructures or near parked cars. A false alert could also occur while making a 90° turn.
- Trailers that have a width greater than 8.5 ft (2.6 m) at the front and have a total length greater than 20 ft (6 m) could cause delayed alerts when a vehicle is passing at high speeds.

- Box trailers that have a width greater than 8.5 ft (2.6 m) at the front could cause early alerts when you pass a vehicle.
- Clam shell or v-nose box trailers with a width greater than 8.5 ft (2.6 m) at the front could cause delayed alerts when a vehicle traveling the same speed as your vehicle merges lanes.

SETTING A TRAILER LENGTH

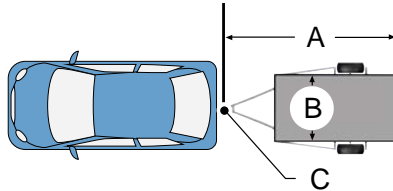

- A Trailer length.
- B Trailer width.
- C Trailer hitch ball.

You can set-up a trailer to work with the blind spot information system through the touchscreen by using the add trailer menu.

1. Input the trailer name and trailer type, conventional, gooseneck or fifth wheel, then save to continue trailer setup.

Note: The system only supports conventional trailers.

2. Trailer width measurement. Measure the width at the front of the trailer. It is not measured at the widest point of the trailer. The maximum width at the front of the trailer the system can support is 8.5 ft (2.6 m).

Note: If the trailer is a bike rack or cargo rack with electrical lighting, enter a length of around 3 ft (1 m). Cross traffic alert remains on for trailers with a length of 3 ft (1 m) or less.

Note: The system requires proper measurement and measure entry to properly function.

SELECTING A TRAILER

When you connect a trailer to your vehicle, the trailer set up menu appears in the touchscreen. This menu allows you to set up a new trailer or choose from a previously set up trailer. A warning message appears and the system turns off if you do not choose or add a new trailer.

Blind Spot Information System

Note: The warning message may not appear until your vehicle reaches 22 mph (35 km/h).

BLIND SPOT INFORMATION SYSTEM INDICATORS



When blind spot information system detects a vehicle, an alert indicator illuminates in the exterior mirror on the side from which the vehicle is approaching. If you turn the turn signal on for that side of your vehicle, the alert indicator flashes.

Blind Spot Information System

BLIND SPOT INFORMATION SYSTEM – TROUBLESHOOTING

BLIND SPOT INFORMATION SYSTEM – INFORMATION MESSAGES

Message	Action
Blind Spot System Fault	A fault with the system has occurred. Have your vehicle checked as soon as possible.
Blind Spot Not Available Sensor Blocked See Manual	Something is blocking the sensors. Clean the sensors.
Blind Spot Alert Deactivated Trailer Attached	The system automatically turns off and displays this message when you connect a trailer to your vehicle under any of the following conditions: <ul style="list-style-type: none">- Your vehicle does not have blind spot information system with trailer coverage.- You switch the blind spot information system off through the touchscreen.- Your trailer exceeds the limits for the system. See Setting a Trailer Length (page 298). Only appears if your vehicle has blind spot information system with trailer coverage.

Note: When connecting a trailer, the system may detect the trailer and turn the system OFF. If the system does not automatically turn OFF, manually switch the blind spot information system OFF. If your vehicle has the blind spot information system with trailer coverage, the system prompts you to set up a trailer that allows the feature to function, if your trailer meets the requirements of the system.

Exit Warning

WHAT IS EXIT WARNING

Exit warning is designed to provide a visual and audible alert when a vehicle occupant opens a door into approaching traffic. It uses radar sensors to alert you to traffic objects approaching your open door.

HOW DOES EXIT WARNING WORK

Exit warning detects traffic objects such as vehicles, cyclists, scooters and motorcycles that approach your vehicle from the rear and cross into the exit warning zone. The exit warning zones are along the left and right sides of your vehicle and extend slightly past a fully open door. The exit warning system becomes active once you have started your vehicle and the vehicle is not moving. Exit warning operates in any gear position.

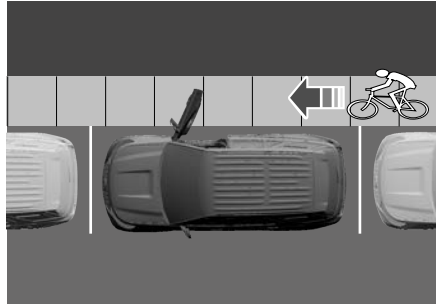



Note: *The system cannot detect animals, slow moving pedestrians or any type of stationary object.*

EXIT WARNING PRECAUTIONS

 **WARNING:** The system is not a crash warning or avoidance system.

 **WARNING:** Always pay attention to the traffic situation and the area around the vehicle.

 **WARNING:** In cold and severe weather conditions the system may not function. Rain, snow and spray can all limit sensor performance.

 **WARNING:** If damage occurs in the immediate area surrounding the sensor, have your vehicle checked as soon as possible.

 **WARNING:** You are responsible for controlling your vehicle at all times. The system is designed to be an aid and does not relieve you of your responsibility to drive, stop and park with due care and attention. Failure to follow this instruction could result in the loss of control of your vehicle, personal injury or death.

 **WARNING:** Exit Warning may not detect objects with surfaces that absorb reflection. Always open doors with due care and attention. Failure to follow this instruction may result in personal injury or property damage.

Exit Warning

EXIT WARNING LIMITATIONS

Exit warning shuts off approximately three minutes after you switch your vehicle off, or immediately after you lock your doors. When your vehicle switches off to conserve battery power on a low battery, exit warning also shuts off. When exit warning turns off, a message appears in the instrument cluster display.

Note: Do not use exit warning as a replacement for paying attention when exiting your vehicle.

Note: The system does not prevent contact with other vehicles by automatically closing the doors.

Note: The system may not inform or alert you if a traffic object is approaching too quickly or if the parking position prevents detection.

Exit Warning and Power Child Lock (If Equipped)

Power child lock remains active and must be manually deactivated. A visual warning occurs if you attempt to switch it off at the same time exit warning detects an approaching traffic object.

A visual warning occurs in this situation.

Note: The driver can override the exit warning with power child lock function by quickly pressing the power child lock deactivation button twice within 5 seconds.

Note: When the exit warning and power child lock function is activated, the doors can still be opened from the outside.

EXIT WARNING INDICATORS



When exit warning detects an approaching traffic object on one side, the corresponding alert indicator in the exterior mirror is illuminated. If exit warning alert or the optional exit warning prevention are active, the same alert indicator flashes. See **Blind Spot Information System Indicators** (page 299).

In addition to the mirror indicator there is also visual indicator in the information display noting what side a traffic object has been detected on.

SWITCHING EXIT WARNING ON AND OFF

You can switch off the exit warning system using the touchscreen.

Note: The system remembers the last setting when you start your vehicle.

Exit Warning

LOCATING THE EXIT WARNING SENSORS



The sensors are behind the rear bumper on both sides of your vehicle.

Note: Keep the sensors free from snow, ice and large accumulations of dirt.

Note: Do not cover the sensors with bumper stickers, repair compound or other objects.

Note: Blocked sensors may affect system accuracy.

Note: The system may not correctly operate when towing a trailer or bike rack.

EXIT WARNING – TROUBLESHOOTING

EXIT WARNING – INFORMATION MESSAGES

Message	Reason
Left/Right Side Check surroundings before exiting	Left/Right exit warning alert or exit warning prevention is active.
Exit Warning turning off. Exit safely	Displays when the exit warning system turns off or shuts down.
Exit Warning System Fault	Displays when the exit warning system detects any system error.

If exit warning detects a fault, the system deactivates and a **System Fault** message appears in the instrument cluster display.

Cross Traffic Alert

WHAT IS CROSS TRAFFIC ALERT

The system is designed to alert you of road users and traffic objects approaching from the rear sides and from behind your vehicle when you shift into reverse (R).

If you continue to reverse after the system alerts you, the system is designed to apply the brakes if it still detects approaching road users or traffic objects. If the system applies the brakes, a message appears in the instrument cluster display.

Note: *There could be instances when unexpected or unwanted braking occurs. You can override this by firmly pressing the accelerator pedal.*

HOW DOES CROSS TRAFFIC ALERT WORK

Cross Traffic Alert is designed to detect road users or traffic objects approaching above a minimum speed of 5 mph (8 km/h). Coverage can decrease when the sensors are partially, mostly or fully obstructed.

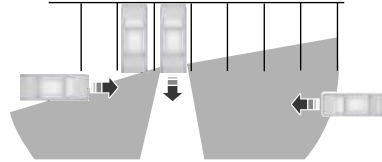

The sensor on the left-hand side is only partially obstructed and zone coverage on the right-hand side is maximized.

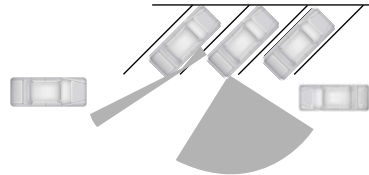

Zone coverage also decreases when parking at narrow angles. The sensor on the left-hand side is mostly obstructed and zone coverage on that side is severely reduced.

Note: *Slowly reversing helps increase the coverage area and effectiveness.*

The system only applies the brakes for a short period of time when an event occurs. Take action as soon as you notice the system applying the brakes in order to remain in control of your vehicle, the system does not do this for you.

CROSS TRAFFIC ALERT PRECAUTIONS

⚠ WARNING: You are responsible for controlling your vehicle at all times. The system is designed to be an aid and does not relieve you of your responsibility to drive with due care and attention. Failure to follow this instruction could result in the loss of control of your vehicle, personal injury or death.

⚠ WARNING: If damage occurs in the immediate area surrounding the sensor, have your vehicle checked as soon as possible.

⚠ WARNING: To help avoid personal injury, always use caution when in reverse (R) and when using the sensing system.

Cross Traffic Alert

 **WARNING:** The system may not operate properly during severe weather conditions, for example snow, ice, heavy rain and spray. Always drive with due care and attention. Failure to take care may result in a crash.

 **WARNING:** The system may not detect objects with surfaces that absorb reflection. Always drive with due care and attention. Failure to take care may result in a crash.

 **WARNING:** Traffic control systems, fluorescent lamps, inclement weather, air brakes, external motors and fans may affect the correct operation of the sensing system. This may cause reduced performance or false alerts.

 **WARNING:** Some situations and objects prevent hazard detection, for example, inclement weather, unconventional vehicle types and pedestrians. Apply the brakes when necessary. Failure to follow this instruction could result in the loss of control of your vehicle, personal injury or death.

 **WARNING:** Do not use the system with accessories that extend beyond the front or rear of your vehicle, for example a trailer hitch or bike rack. The system is not able to make corrections for the additional length of the accessories.

 **WARNING:** Do not use the cross traffic alert system as a replacement for using the interior and exterior mirrors or looking over your shoulder before reversing out of a parking space. The cross traffic alert system is not a replacement for careful driving.

Note: *Certain add-on devices around the bumper or fascia may cause unexpected system behavior. For example, large trailer hitches, bicycle or surfboard racks, license plate brackets, fuel containers, bumper covers or any other device may block the normal detection zone of the system. Remove the add-on device to prevent unexpected system behavior.*

Note: *If your vehicle sustains damage to the bumper or fascia leaving it misaligned or bent, it could alter the sensing zone causing inaccurate measurement of obstacles or false alerts.*

Note: *Vehicle loading and suspension changes can impact the angle of the sensors and may change the normal detection zone of the system resulting in inaccurate measurement of obstacles or false alerts.*

Note: *You may experience reduced system performance on road surfaces that limit deceleration. For example, roads with ice, loose gravel, mud or sand.*

CROSS TRAFFIC ALERT LIMITATIONS

The system may not correctly operate when any of the following occur:

- Something is blocking the sensors.
- Adjacently parked vehicles or objects are obstructing the sensors.
- Traffic objects approach at speeds less than 5 mph (8 km/h) or greater than 37 mph (60 km/h).
- Your vehicle speed is greater than 7 mph (12 km/h).
- You reverse out of an angled parking space.
- If you switch the traction system off, cross traffic alert does not apply the brakes.

Cross Traffic Alert

Note: The system does not alert for small stationary and moving objects.

Cross Traffic Alert Limitations with a Trailer Attached

The system remains on when you attach a trailer to vehicles with blind spot information system with trailer coverage under the following conditions:

- You connect a bike rack or cargo rack with a maximum length of 3 ft (1 m).
- You set the trailer length to 3 ft (1 m) in the touchscreen.

Note: The system may not correctly operate when towing a trailer. For vehicles with an approved trailer tow module and tow bar, the system turns off when you attach a trailer greater than 3 ft (1 m). For vehicles with an aftermarket trailer tow module or tow bar, we recommend that you switch the system off when you attach a trailer.

SWITCHING CROSS TRAFFIC ALERT ON AND OFF

1. From the settings menu, press Driver Assistance.

2. Press Cross Traffic Alert.
3. Switch the feature on or off.

When you switch the system on or off, the alert indicators flash twice.

Note: The system switches on every time you switch the ignition on.

LOCATING THE CROSS TRAFFIC ALERT SENSORS

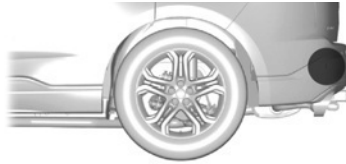

The sensors are behind the rear bumper on both sides of your vehicle.

Note: Keep the sensors free from snow, ice and large accumulations of dirt.

Note: Do not cover the sensors with bumper stickers, repair compound or other objects.

Note: Blocked sensors may affect system accuracy.

Note: Bike and cargo racks could cause false alerts due to obstruction of the sensor. We recommend switching the feature off when using a bike or cargo rack.

If something is blocking the sensors, a message may appear in the information display when you shift into reverse (R).

CROSS TRAFFIC ALERT INDICATORS



When the system detects an approaching vehicle, a tone sounds, an alert indicator illuminates in the relevant exterior mirror and arrows appear in the touchscreen to show from which side the vehicle is approaching.

If the system malfunctions, a message appears. Have your vehicle checked as soon as possible.

Note: In exceptional conditions, the system could alert you or apply the brakes, even when there is nothing in the detection zone, for example a vehicle passing further away from your vehicle.

Cross Traffic Alert

CROSS TRAFFIC ALERT – TROUBLESHOOTING

CROSS TRAFFIC ALERT – INFORMATION MESSAGES

Message	Details
Cross Traffic Alert	Displays when the system detects a vehicle. Check for approaching traffic.
Cross Traffic Not Available Sensor Blocked See Manual	Displays if the cross traffic alert system sensors are blocked. Clean the sensors. If the message continues to appear, have your vehicle checked as soon as possible.
Cross Traffic System Fault	The system has malfunctioned. Have your vehicle checked as soon as possible.
Cross Traffic Alert Deactivated Trailer Attached	Displays if you attach a trailer to your vehicle.
Cross Traffic Alert Applying Brakes	Displays if the system applies the brakes. Check for approaching traffic.

Note: *If your vehicle has reverse brake assist*
See **Reverse Brake Assist – Information Messages** (page 221).

Pre-Collision Assist

WHAT IS PRE-COLLISION ASSIST

Pre-collision assist detects and warns of approaching hazards in the roadway. The system provides multiple levels of assistance to help avoid a collision if your vehicle is rapidly approaching another stationary vehicle, a vehicle traveling in the same direction as yours, or a pedestrian or cyclist within your driving path.

HOW DOES PRE-COLLISION ASSIST WORK

The system warns the driver of potential hazards by providing three levels of assistance.



If your vehicle is rapidly approaching potential hazards the system provides the following levels of functionality:

1. Alert.
2. Brake support.
3. Automatic emergency braking.



Alert: When active, a flashing visual warning appears and an audible warning tone sounds.

Brake Support: The system helps reduce the impact speed by preparing the brakes for rapid braking. The system does not automatically apply the brakes. If you press the brake pedal, the system may apply additional braking up to maximum braking force, even if you lightly press the brake pedal.

Automatic Emergency Braking: Automatic emergency braking may activate if the system determines that a collision is imminent.

Note: *If the pre-collision assist alerts are too frequent or disturbing, you can reduce the alert sensitivity. Setting the low sensitivity results in fewer and later warnings of a potential forward collision. The manufacturer recommends using the high sensitivity setting where possible.*

Note: *Automatic emergency braking performance is not affected by the sensitivity setting.*

Each system has various levels of detection capabilities. See **Pre-Collision Assist Limitations** (page 309).

PRE-COLLISION ASSIST PRECAUTIONS



WARNING: You are responsible for controlling your vehicle at all times. The system is designed to be an aid and does not relieve you of your responsibility to drive with due care and attention. Failure to follow this instruction could result in the loss of control of your vehicle, personal injury or death.





WARNING: The system only provides limited braking. Your vehicle may not always decelerate quickly enough to avoid a crash without driver intervention. Apply the brakes when necessary.





WARNING: The system does not operate during hard acceleration or steering. Failure to take care may lead to a crash or personal injury.

Pre-Collision Assist

 **WARNING:** The system may operate with reduced function during cold and inclement weather conditions. Snow, ice, rain, spray and fog can adversely affect the system. Keep the front camera and radar free of snow and ice. Failure to follow this instruction may result in the loss of control of your vehicle, serious personal injury or death.

 **WARNING:** The system may not function properly if your vehicle is fitted with a replacement windshield not approved by us.

 **WARNING:** Do not perform windshield repairs around the rear-view mirror. Failure to follow this instruction could limit sensor performance.

 **WARNING:** System performance could be reduced in situations where the vehicle camera has limited detection capability. These situations include but are not limited to direct or low sunlight, vehicles at night without tail lights, unconventional vehicle types, pedestrians or cyclists with complex backgrounds,

running pedestrians or fast moving cyclists, partly obscured pedestrians or cyclists, pedestrians or cyclists that the system cannot distinguish from a group. Failure to take care may result in the loss of control of your vehicle, personal injury or death.

 **WARNING:** The system cannot help prevent all crashes. Do not rely on this system to replace driver judgment and the need to maintain a safe distance and speed.

 **WARNING:** Take additional care if your vehicle is heavily loaded or you are towing a trailer. These conditions could result in reduced performance of this system. Failure to follow this instruction could result in the loss of control of your vehicle, personal injury or death.

Note: *Automatic emergency braking may activate when a collision is imminent. The system cannot prevent all crashes, but may reduce crash severity. Do not test automatic emergency braking or forward collision warning. Testing this system must only be conducted by authorized test facilities using specialized equipment. Do not use automatic emergency braking to replace normal braking for any reason. Relying on automatic emergency braking to stop your vehicle may cause an unexpected accident which could lead to serious injury or death.*

Note: *The system does not detect animals.*

PRE-COLLISION ASSIST LIMITATIONS

Pre-collision assist depends on the detection ability of its camera and sensors. Any obstructions or damage to these areas can limit detection or prevent the system from functioning. See **Locating the Pre-Collision Assist Sensors** (page 312).

The system is active at 3 mph (5 km/h) and above.

Pre-Collision Assist

Note: The pre-collision assist system automatically disables if your vehicle has the following drive modes and you select four-wheel drive low or manually disable AdvanceTrac™ and rock crawl mode.

Note: Brake support and automatic emergency braking can detect other vehicles up to the maximum speed of your vehicle.

Pedestrian Detection Limitations

Pedestrian detection is active at speeds up to 50 mph (80 km/h).

Pedestrian detection operates optimally when detected hazards are clearly identifiable. The system can have reduced performance in situations where pedestrians are running, partly obscured, have a complex background, or when the system cannot distinguish them from a group.

Cyclist Detection Limitations

Cyclist detection is active at speeds up to 50 mph (80 km/h).

Cyclist detection functions optimally when detected hazards are clearly identifiable. The system can have reduced performance in situations where cyclists are fast-moving, partly obscured, have a complex background, or where the system cannot distinguish them from a group.

Intersection Assist

The system operates when you turn across the path of an oncoming vehicle, or a pedestrian or cyclist crossing the road. Detection of oncoming vehicles is active if you are driving your vehicle at speeds up to 19 mph (30 km/h). Detection of crossing pedestrians or cyclists at an intersection is active if you are driving your vehicle at speeds up to 19 mph (30 km/h). The system also operates when you approach the path of a crossing vehicle. Detection of crossing vehicles is active if you are driving your vehicle at speeds up to 40 mph (65 km/h).

Note: In the following intersection scenarios, your vehicle is represented in yellow.

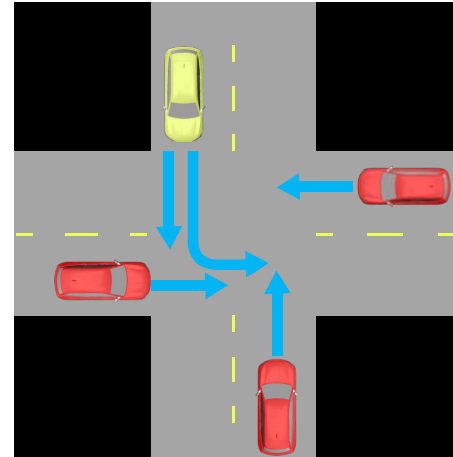

The previous image shows potential intersection scenarios from the perspective of the yellow vehicle. The system may detect the red vehicles if you encounter them within the appropriate detection speed.

Pre-Collision Assist

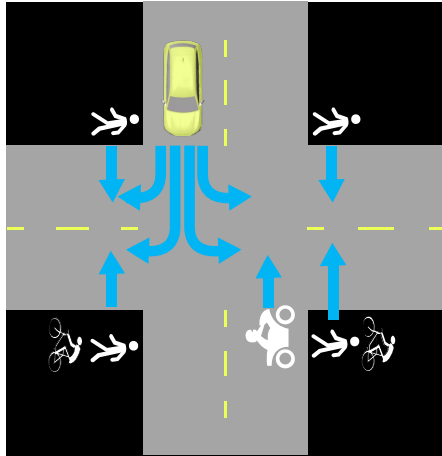

The previous image shows potential motorcycle, bicycle, and pedestrian intersection scenarios from the perspective of the yellow vehicle. The system may detect these threats if you encounter them within the appropriate detection speed.

Pre-Collision Assist - Oncoming Vehicles

This feature expands the function of pre-collision assist to oncoming vehicles within your same lane. The system can help to reduce the severity of a crash by providing a warning to you as well as automatically applying the brakes. Detection of oncoming vehicles is active if you are driving your vehicle above 19 mph (30 km/h).

SWITCHING PRE-COLLISION ASSIST ON AND OFF

You cannot switch the system off.

Adjusting the Pre-Collision Assist Settings

You can adjust the following settings by using the touchscreen controls in the pre-collision assist menu:

- Change alert sensitivity to one of three possible settings.
- If required, switch automatic emergency braking on or off.
- If required, switch evasive steering assist on or off.

Note: Automatic emergency braking and evasive steering assist automatically turn on every time you start your vehicle.

Note: If you switch automatic emergency braking off, evasive steering assist switches off.

Pre-Collision Assist

LOCATING THE PRE-COLLISION ASSIST SENSORS

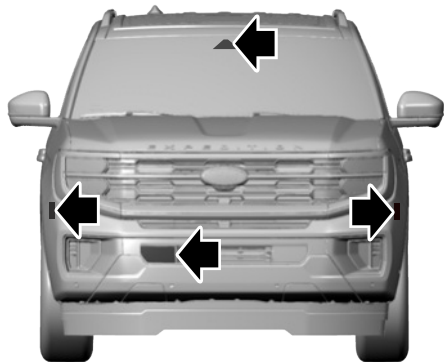

Top: Camera.

Bottom: Radar sensor.

Sides: Corner radar (if equipped).

If a message regarding a blocked sensor or camera appears in the instrument cluster display, something is obstructing the radar or front windshield camera. The radar sensor is behind the fascia in the center of the lower grille. With a blocked sensor or camera, the system may not function, or performance may reduce. See **Pre-Collision Assist – Information Messages** (page 314).

Note: Proper system operation requires a clear view of the road by the camera. Repair any windshield damage in the area of the camera's field of view.

Note: If your vehicle has a radar sensor, and something hits the front end of your vehicle or damage occurs, the radar sensing zone could change. This may cause missed or false vehicle detections. Have your vehicle serviced to have the radar checked for proper coverage and operation.

Note: If your vehicle detects excessive heat at the camera or a potential misalignment condition, a message may display in the instrument cluster display indicating temporary sensor unavailability. When operational conditions are correct, the message disappears. For example, when the ambient temperature around the sensor decreases or the sensor successfully recalibrates.

FORWARD COLLISION WARNING

WHAT IS FORWARD COLLISION WARNING

A warning flashes and an audible warning sounds if your vehicle rapidly approaches another vehicle to warn you of the risk of a crash with the vehicle in front of you.

ADJUSTING THE SENSITIVITY OF FORWARD COLLISION WARNING

1. From the settings menu, press Driver Assistance.
2. Press Pre-Collision Assist.
3. Press Alert Sensitivity.
4. Select a setting.

Pre-Collision Assist

AUTOMATIC EMERGENCY BRAKING

WHAT IS AUTOMATIC EMERGENCY BRAKING

Automatic emergency braking may activate if the system determines that a collision is imminent. The system may help to reduce impact damage or completely avoid the crash.

SWITCHING AUTOMATIC EMERGENCY BRAKING ON AND OFF

1. From the settings menu, press Driver Assistance.
2. Press Pre-Collision Assist.
3. Press Auto Emergency Braking.
4. Switch the feature on or off.

Note: A telltale remains illuminated in the instrument cluster when automatic emergency braking is switched off using the settings menu.

EVASIVE STEERING ASSIST

WHAT IS EVASIVE STEERING ASSIST

If your vehicle is rapidly approaching a road user, evasive steering assist helps you steer around the road user.

After you turn the steering wheel in an attempt to avoid a crash with the road user, the system applies additional steering torque to help you steer around the road user. After you pass the road user, the system applies steering torque when you turn the steering wheel to steer back into the lane. The system deactivates after you fully pass the road user.

Note: Road users are defined as pedestrians or bicyclists in your vehicle's path or another stationary vehicle in the same lane or a vehicle traveling in the same lane in the same direction as you. See **Pre-Collision Assist Precautions** (page 308).

EVASIVE STEERING ASSIST LIMITATIONS

Evasive steering assist only activates when all the following occur:

- Automatic emergency braking and evasive steering assist are on.
- The system detects a road user ahead and starts to apply the brakes.
- You significantly turn the steering wheel to steer around a road user.

Note: Evasive steering assist does not automatically steer around a road user. If you do not turn the steering wheel, evasive steering assist does not activate.

Note: Evasive steering assist does not activate if the distance to the road user ahead is too small and the system cannot avoid a crash.

SWITCHING EVASIVE STEERING ASSIST ON AND OFF

1. From the settings menu, press Driver Assistance.
2. Press Pre-Collision Assist.
3. Press Evasive Steering Assist.
4. Switch the feature on or off.

Pre-Collision Assist

Note: If you switch automatic emergency braking off, evasive steering assist turns off.

Note: Automatic emergency braking and evasive steering assist turn on every time you start your vehicle.

PRE-COLLISION ASSIST – TROUBLESHOOTING

PRE-COLLISION ASSIST – WARNING LAMPS



A telltale illuminates in the instrument cluster display to indicate if the system is disabled, unavailable, or temporarily degraded due to external environmental conditions.

Note: If the telltale illuminates without a corresponding information message, make sure the setting for automatic emergency braking is switched on. See **Switching Automatic Emergency Braking On and Off** (page 313). No action is needed unless an information message appears. See **Pre-Collision Assist Precautions** (page 308).

PRE-COLLISION ASSIST – INFORMATION MESSAGES

Message	Action
Pre-Collision Assist Not Available Sensor Blocked	You have a blocked sensor due to bad weather, ice, mud or water in front of the radar sensor. You can typically clean the sensor to resolve.
Pre-Collision Assist Not Available	A fault with the system has occurred. Have your vehicle checked as soon as possible.

Pre-Collision Assist

PRE-COLLISION ASSIST – FREQUENTLY ASKED QUESTIONS

What should I do if the windshield in front of the camera is dirty or obstructed?

- Clean the outside of the windshield in front of the camera.

What if the windshield in front of the camera is clean, but the message remains in the instrument cluster display?

- Wait a short time. It could take several minutes for the camera to detect that there is no obstruction.

What should I do if the surface of the radar in the grille is dirty or obstructed?

- Clean the grille surface in front of the radar or remove the object causing the obstruction.

What if the surface of the radar in the grille is clean, but the message remains in the instrument cluster display?

- Wait a short time. It could take several minutes for the radar to detect that there is no obstruction.

Can weather or road conditions interfere with the radar signals?

- Yes, weather such as heavy rain, spray or fog as well as water, snow or ice on the surface of the road can interfere with the radar signals. In these situations, the system temporarily disables this feature. Pre-collision assist reactivates a short time after the weather conditions improve.

What if the radar is out of alignment due to a front end impact?

- Have your vehicle serviced to have the radar checked for proper coverage and operation.

Speed Sign Recognition

WHAT IS SPEED SIGN RECOGNITION

Speed sign recognition detects speed limit signs to inform you of the current speed limit. Detected speed signs appear in the instrument cluster display.

HOW DOES SPEED SIGN RECOGNITION WORK

Speed sign recognition uses the front windshield camera to detect speed signs.

If your vehicle has speed sign recognition with Map Data, stored speed sign data may influence the indicated speed limit value.

SPEED SIGN RECOGNITION PRECAUTIONS



WARNING: You are responsible for controlling your vehicle at all times. The system is designed to be an aid and does not relieve you of your responsibility to drive with due care and attention. Failure to follow this instruction could result in the loss of control of your vehicle, personal injury or death.



WARNING: In cold and severe weather conditions the system may not function. Rain, snow and spray can all limit sensor performance.



WARNING: The system may not operate properly if the sensor is blocked. Keep the windshield free from obstruction.



WARNING: Do not perform windshield repairs around the rear-view mirror. Failure to follow this instruction could limit sensor performance.



WARNING: The system may not correctly operate if your vehicle is fitted with a suspension kit not approved by Ford.



WARNING: Not all traffic signs can be recognized by the system and displayed correctly.

Note: Always fit our original parts when replacing headlamp bulbs. Other bulbs may reduce system performance.

SPEED SIGN RECOGNITION LIMITATIONS

Speed sign recognition may not detect the correct speed due to:

- Construction zones.
- Outdated map data.
- Incorrect recognition of speed limits by the sensor of signs on parallel roads or exit ramps.
- Missed recognition of faded, dirty, or distorted signs.

Note: The system may not detect all speed signs and may incorrectly read signs.

Speed Sign Recognition

SPEED SIGN RECOGNITION INDICATORS



When the system detects a speed limit sign, it appears in the instrument cluster display.

Note: *Sign indicator image may vary based on your vehicle's display type.*

SPEED SIGN RECOGNITION SETTINGS

1. From the settings menu, press driver assistance.
2. Press Speed Limit Assist.

You can adjust the following settings:

- Switch the speed warning on or off.
- Set the speed limit tolerance (if equipped).



If you see this icon next to a menu option, press it for more information.

SPEED SIGN RECOGNITION – TROUBLESHOOTING

SPEED SIGN RECOGNITION – INFORMATION MESSAGES

Message	Details
Traffic Sign Reduced Performance See Manual	The traffic sign data provided by the Map Data is unavailable due to weak or no signal. Wait for a short period of time for the signal to improve. If the message continues to appear, have the system checked as soon as possible.

Speed Sign Recognition

SPEED SIGN RECOGNITION – FREQUENTLY ASKED QUESTIONS

Why does the speed limit change without any sign on the road?

- The speed limit changes due to the speed limit data stored in the map data.

Why does speed sign recognition show a wrong speed limit?

- The system shows a wrong speed limit due to incorrect and outdated map data or due to incorrect recognition of the speed limits by the camera.

Driver Alert

WHAT IS DRIVER ALERT

Driver alert alerts you if it determines that you are becoming drowsy or if your driving deteriorates.

HOW DOES DRIVER ALERT WORK

Driver alert determines your alertness level based on your driving behavior in relation to the lane markings and other factors using the front windshield camera.

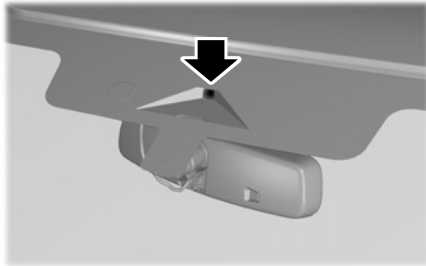

DRIVER ALERT PRECAUTIONS

WARNING: You are responsible for controlling your vehicle at all times. The system is designed to be an aid and does not relieve you of your responsibility to drive with due care and attention. Failure to follow this instruction could result in the loss of control of your vehicle, personal injury or death.

WARNING: Take regular rest breaks if you feel tired. Do not wait for the system to warn you.

WARNING: Certain driving styles may result in the system warning you even if you are not feeling tired.

WARNING: In cold and severe weather conditions the system may not function. Rain, snow and spray can all limit sensor performance.

WARNING: The system will not operate if the sensor cannot track the road lane markings.

WARNING: If damage occurs in the immediate area surrounding the sensor, have your vehicle checked as soon as possible.

WARNING: The system may not correctly operate if your vehicle is fitted with a suspension kit not approved by us.

WARNING: The system may not operate properly if the sensor is blocked. Keep the windshield free from obstruction.

Note: *If something is blocking the camera or damaged the windshield, Driver Alert may not function.*

DRIVER ALERT LIMITATIONS

Driver alert may not function correctly if:

- The sensor cannot track the road lane markings.
- Your vehicle's speed is less than approximately 40 mph (65 km/h).

Driver Alert

SWITCHING DRIVER ALERT ON AND OFF

1. From the settings menu, press Driver Assistance.
2. Press Driver Alert.
3. Switch the feature on or off.

DRIVER ALERT INDICATORS

System Warnings

The warning system has two stages:

1. A temporary warning is issued to advise you to take a rest. This message only appears for a short time.

2. If you do not rest and the system continues to detect that your driving deteriorates, it issues a further warning. This remains in the instrument cluster display until you cancel it.

Note: *The system does not warn you if the vehicle speed falls below approximately 40 mph (65 km/h).*



If there is a fault in the system, a telltale will appear in the instrument cluster display.

DRIVER ALERT – TROUBLESHOOTING

DRIVER ALERT – INFORMATION MESSAGES

Message	Action
Driver Alert Warning Rest Now	Stop and rest as soon as it is safe to do so.
Driver Alert Warning Rest Suggested	Take a rest soon.

Load Carrying

LOAD CARRYING PRECAUTIONS

Keep your loaded vehicle weight within its design rating capability, with or without a trailer. Properly loading your vehicle provides maximum return of vehicle design performance. Before you load your vehicle, become familiar with the following terms for determining your vehicle's weight rating, with or without a trailer, from the vehicle's Tire and Loading Information label or Safety Compliance Certification label.

WARNING: The appropriate loading capacity of your vehicle can be limited either by volume capacity (how much space is available) or by payload capacity (how much weight the vehicle should carry). Once you have reached the maximum payload of your vehicle, do not add more cargo, even if there is space available. Overloading or improperly loading your vehicle can contribute to loss of vehicle control and vehicle rollover.

WARNING: Exceeding the Safety Compliance Certification label vehicle weight limits can adversely affect the performance and handling of your vehicle, cause vehicle damage and can result in the loss of control of your vehicle, serious personal injury or death.

WARNING: Do not use replacement tires with lower load carrying capacities than the original tires because they may lower your vehicle's GVWR and GAWR limitations. Replacement tires with a higher limit than the original tires do not increase the GVWR and GAWR limitations.

WARNING: Do not exceed the GVWR or the GAWR specified on the certification label.



WARNING: Exceeding any vehicle weight rating can adversely affect the performance and handling of your vehicle, cause vehicle damage and can result in the loss of control of your vehicle, serious personal injury or death.

WARNING: When loading the roof racks, we recommend you evenly distribute the load, as well as maintain a low center of gravity. Loaded vehicles, with higher centers of gravity, may handle differently than unloaded vehicles. Take extra precautions, such as slower speeds and increased stopping distance, when driving a heavily loaded vehicle.

The gross combined weight must never exceed the Gross Combined Weight Rating.

LOCATING THE SAFETY COMPLIANCE CERTIFICATION LABELS

Safety Compliance Certification Label Example:

<p>MFD. BY FORD MOTOR CO. DATE: XXXX GVWR: XXXX KG (XXXX LB) FRONT GAWR: XXXX KG (XXXX LB) REAR GAWR: XXXX KG (XXXX LB) XXXX KG (XXXX LB) WITH TIRE XXXX KG (XXXX LB) WITH TIRE XXXXXXXXXXXXXXXX TRES XXXXXXXXXXXXXXXX TRES XXXXXXX TRES XXXXXXX TRES AT XXXX kPa/ XXX PSI (G) AT XXXX kPa/ XXX PSI (G) THE VEHICLE CONFORMS TO ALL APPLICABLE FEDERAL MOTOR VEHICLE SAFETY AND THEIR PRECURSOR STANDARDS IN EFFECT ON THE DATE OF MANUFACTURE SHOWN ABOVE. VIN: XXXXXXXXXXXXXXXXXXXX XXXX TIRE: XXXX XXXX  ECENE: 00 XXXXX 00000 00000 00000 00 00 00 00 00 00 00 00 00 00 00 00 00 00 00 00 00 00 00 00 00 00 00 00 00 00 00 00 00 00 00 00 000000000000 000 000000000000</p>	<p>MFD. BY FORD MOTOR CO. DATE: XXXX GVWR: XXXX KG (XXXX LB) FRONT GAWR/PWB IV / REAR GAWR/PWB IIX XXXX KG (XXXX LB) / XXXX KG (XXXX LB) WET/DYNAMIC TRES/PWB XXXX XXXXXX XXXX XXXXXX XXXXXXX TRES/PWB XXXXXXX TRES/PWB AT XXXX kPa/ XXX PSI (G) AT XXXX kPa/ XXX PSI (G) THE VEHICLE CONFORMS TO ALL APPLICABLE FEDERAL MOTOR VEHICLE SAFETY AND THEIR PRECURSOR STANDARDS IN EFFECT ON THE DATE OF MANUFACTURE SHOWN ABOVE. VIN: XXXXXXXXXXXXXXXXXXXX XXXX TIRE: XXXX XXXX  ECENE: 00 XXXXX 00000 00000 00000 00 00 00 00 00 00 00 00 00 00 00 00 00 00 00 00 00 00 00 00 00 00 00 00 00 00 00 00 00 00 00 00 000000000000 000 000000000000</p>
--	---

Load Carrying

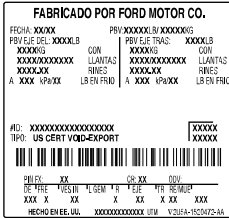

The Safety Compliance Certification label is located on the door pillar, door latch post, or the door edge that meets the door latch post, next to the driver seat.

WHAT IS THE GROSS AXLE WEIGHT RATING

GAWR (Gross Axle Weight Rating)

GAWR is the maximum allowable weight that a single axle (front or rear) can carry. These numbers are on the Safety Compliance Certification label.

WHAT IS THE GROSS VEHICLE WEIGHT RATING

GVWR is the maximum allowable weight of the fully loaded vehicle. This includes all options, equipment, passengers and cargo. It appears on the Safety Compliance Certification label.

WHAT IS THE GROSS COMBINED WEIGHT RATING

Gross Combined Weight Rating (GCWR) is the maximum allowable weight of the vehicle and the loaded trailer, including all cargo and passengers, that the vehicle can handle without risking damage. (Important: The towing vehicle's braking system is rated for operation at Gross Vehicle Weight Rating, not at Gross Combined Weight Rating.) Separate functional brakes should be used for safe control of towed vehicles and for trailers where the Gross Combined Weight of the towing vehicle plus the trailer exceed the Gross Vehicle Weight Rating of the towing vehicle. See **Recommended Towing Weights** (page 338).

CALCULATING PAYLOAD

Tire and Loading Label Information Example:

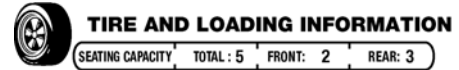

The combined weight of occupants, 385 kg or 850 lbs. and cargo should never exceed

TIRE	SIZE	COLD TIRE PRESSURE
FRONT	235/45R18 94V	235 KPA, 34 PSI
REAR	235/45R18 94V	235 KPA, 34 PSI
SPARE	NONE	NONE

SEE OWNERS
MANUAL FOR
ADDITIONAL
INFORMATION

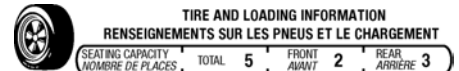

The combined weight of occupants and cargo should never exceed 396 kg or 875 lbs. Le poids total des occupants et du chargement ne doit jamais dépasser

TIRE	SIZE	COLD TIRE PRESSURE
FRONT AVANT	235/40R19 96V	255 KPA, 37 PSI
REAR ARRIERE	235/40R19 96V	255 KPA, 37 PSI
SPARE DE SECOURS	T125/80R16 97M	415 KPA, 60 PSI

SEE OWNER'S
MANUAL FOR
ADDITIONAL
INFORMATION
VOIR LE MANUEL
DE L'USAGER
POUR PLUS DE
RENSEIGNEMENTS

Load Carrying

Payload is the combined weight of cargo and passengers that your vehicle is carrying. The maximum payload for your vehicle appears on the Tire and Loading label. The label is either on the B-pillar or the edge of the driver door. Vehicles exported outside the US and Canada may not have a tire and loading label. Look for “The combined weight of occupants and cargo should never exceed XXX kg or XXX lb” for maximum payload. The payload listed on the Tire and Loading Information label is the maximum payload for your vehicle as built by the assembly plant. If you install any additional equipment on your vehicle, you must determine the new payload. Subtract the weight of the equipment from the payload listed on the Tire and Loading label. When towing, trailer tongue weight or king pin weight is also part of payload.

CALCULATING THE LOAD LIMIT

Steps for determining the correct load limit:

1. Locate the statement "The combined weight of occupants and cargo should never exceed XXX kg or XXX lb." on your vehicle's placard.
2. Determine the combined weight of the driver and passengers that will be riding in your vehicle.

3. Subtract the combined weight of the driver and passengers from XXX kg or XXX lb.
4. The resulting figure equals the available amount of cargo and luggage load capacity. For example, if the “XXX” amount equals 1,400 lb. and there will be five 150 lb. passengers in your vehicle, the amount of available cargo and luggage load capacity is 650 lb. $(1400 - 750 (5 \times 150) = 650 \text{ lb.})$
5. Determine the combined weight of luggage and cargo being loaded on the vehicle. That weight may not safely exceed the available cargo and luggage load capacity calculated in Step 4.
6. If your vehicle will be towing a trailer, load from your trailer will be transferred to your vehicle. Consult this manual to determine how this reduces the available cargo and luggage load capacity of your vehicle.

Helpful examples for calculating the available amount of cargo and luggage load capacity

Suppose your vehicle has a 1400-pound (635-kilogram) cargo and luggage capacity. You decide to go golfing. Is there enough load capacity to carry you, four of your friends and all the golf bags? You and four friends average 220 pounds (99 kilograms) each and the golf bags weigh approximately 30 pounds (13.5 kilograms) each. The calculation would be: $1400 - (5 \times 220) - (5 \times 30) = 1400 - 1100 - 150 = 150$ pounds. Yes, you have enough load capacity in your vehicle to transport four friends and your golf bags. In metric units, the calculation would be: $635 \text{ kilograms} - (5 \times 99 \text{ kilograms}) - (5 \times 13.5 \text{ kilograms}) = 635 - 495 - 67.5 = 72.5$ kilograms.

Suppose your vehicle has a 1400-pound (635-kilogram) cargo and luggage capacity. You and one of your friends decide to pick up cement from the local home improvement store to finish that patio you have been planning for the past two years. Measuring the inside of the vehicle with the rear seat folded down, you have room for twelve 100-pound (45-kilogram) bags of cement. Do you have enough load capacity to transport the cement to your home? If you

Load Carrying

and your friend each weigh 220 pounds (99 kilograms), the calculation would be: $1400 - (2 \times 220) - (12 \times 100) = 1400 - 440 - 1200 = -240$ pounds. No, you do not have enough cargo capacity to carry that much weight. In metric units, the calculation would be: $635 \text{ kilograms} - (2 \times 99 \text{ kilograms}) - (12 \times 45 \text{ kilograms}) = 635 - 198 - 540 = -103$ kilograms. You will need to reduce the load weight by at least 240 pounds (104 kilograms). If you remove three 100-pound (45-kilogram) cement bags, then the load calculation would be: $1400 - (2 \times 220) - (9 \times 100) = 1400 - 440 - 900 = 60$ pounds. Now you have the load capacity to transport the cement and your friend home. In metric units, the calculation would be: $635 \text{ kilograms} - (2 \times 99 \text{ kilograms}) - (9 \times 45 \text{ kilograms}) = 635 - 198 - 405 = 32$ kilograms.

The above calculations also assume that the loads are positioned in your vehicle in a manner that does not overload the front or the rear gross axle weight rating specified for your vehicle on the Safety Compliance Certification label.

ROOF RACK

ROOF RACK PRECAUTIONS



WARNING: Read and follow the manufacturer's instructions when you are fitting a roof rack.



WARNING: When loading the roof racks, we recommend you evenly distribute the load, as well as maintain a low center of gravity. Loaded vehicles, with higher centers of gravity, may handle differently than unloaded vehicles. Take extra precautions, such as slower speeds and increased stopping distance, when driving a heavily loaded vehicle.

Note: *If you use a roof rack, the fuel consumption of your vehicle will be higher and you may experience different driving characteristics.*

Note: *Never place loads directly on the roof panel. The roof panel is not designed to directly carry a load.*

You must place loads directly on the crossbars fitted to the roof rack side rails. When using the roof rack system, we recommend that you use genuine Ford accessory crossbars specifically designed for your vehicle.

Make sure that you securely fasten the load. Check the tightness of the load before driving and at each fuel stop.

Load Carrying

ROOF RACK LOAD CAPACITIES

Description	Maximum Recommended Load
Vehicles with a glass roof.	125 lb (56 kg)
Vehicles without a glass roof.	200 lb (90 kg)

Note: *The maximum roof load is based on evenly distributing the load on the crossbars.*

Note: *When using a roof rack system, you must subtract the weight of the roof rack system from the maximum recommended load to determine your actual maximum cargo load. See the roof rack system manufacturer for more information.*

Luggage Compartment

LUGGAGE COMPARTMENT PRECAUTIONS

 **WARNING:** Make sure that you properly secure objects in the luggage compartment. Failure to follow this instruction could result in personal injury in the event of a sudden stop or crash.

 **WARNING:** Do not place objects on the luggage cover. Failure to follow this instruction could result in personal injury or death in the event of a sudden stop or crash.

 **WARNING:** The appropriate loading capacity of your vehicle can be limited either by volume capacity (how much space is available) or by payload capacity (how much weight the vehicle should carry). Once you have reached the maximum payload of your vehicle, do not add more cargo, even if there is space available. Overloading or improperly loading your vehicle can contribute to loss of vehicle control and vehicle rollover.

 **WARNING:** Make sure that you fully close the liftgate to prevent exhaust fumes from entering your vehicle. If you are unable to fully close the liftgate, open the air vents or the windows to allow fresh air to enter your vehicle. Failure to follow this instruction could result in personal injury or death.

 **WARNING:** Do not exceed the maximum front and rear axle loads for your vehicle.

Note: *When loading long objects into your vehicle, for example pipes, timber or furniture, be careful not to damage the interior trim.*

INSTALLING AND REMOVING THE LUGGAGE COMPARTMENT CARGO NET

 **WARNING:** This net is not designed to restrain objects during a collision or heavy braking.

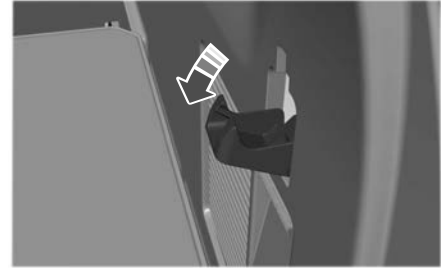

1. Fold down the hooks on the top of the rear quarter trim panel.

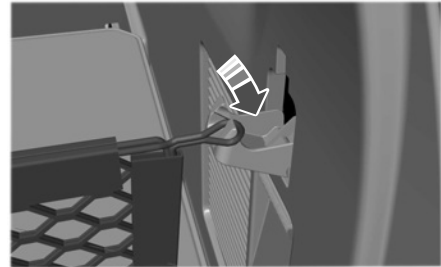

2. Attach the loop end of the net to the upper hook. Use one prong on the hook for the net attachment.

Luggage Compartment

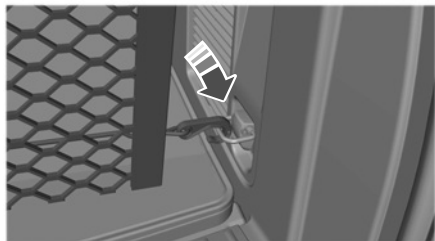

3. Attach the bottom of the net to the lower anchor point.

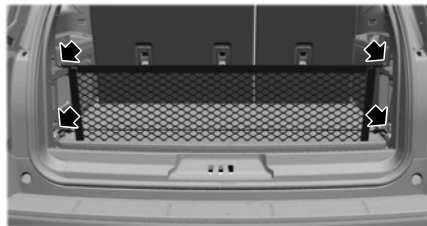

4. Repeat this procedure on the other side of your vehicle.

ADJUSTING THE LUGGAGE COMPARTMENT LOAD FLOOR

Short Wheelbase Load Floor



Lift up on the handle to open the cover.

Note: The board operates with friction hinges. This allows you to put it in any position between a 0° and a 90° angle.

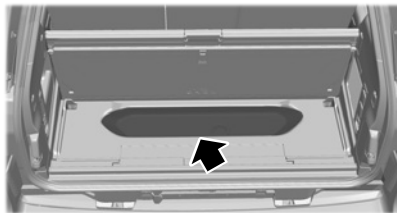

To close, lower the cover.

Long Wheelbase Load Floor

The load floor provides access to two separate storage compartments.

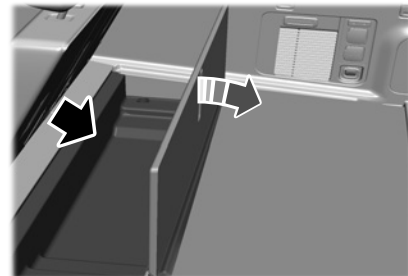

Lift up on the handle and fold the cover back to access the first storage compartment.

Note: The board operates with friction hinges. This allows you to put it in any position between a 0° and a 90° angle.

Luggage Compartment

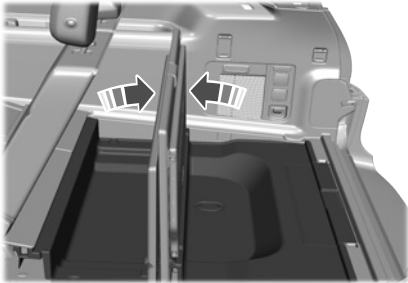

To access the second storage compartment, fold the rear cover.

To close, lower the covers.

ADJUSTING THE LUGGAGE COMPARTMENT DIVIDER

Advanced Luggage Compartment Divider (If Equipped)

WARNING: Do not load any objects on the shelf that may obstruct your vision or strike occupants of the vehicle in the case of a sudden stop or collision.

WARNING: Do not place people or pets on or under the parcel shelf.

Forward Divider



To move the board into the divider position, lift up on the handle and position the board vertically at a 90° angle.

Note: The board operates with friction hinges. This allows you to put it in any position between 0–90° angle.

Cargo Shelf

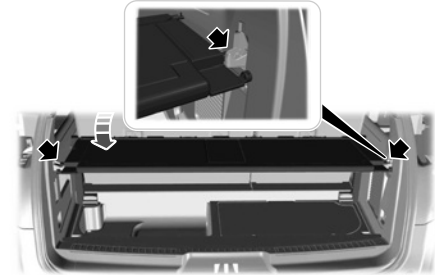

To move the board into the shelf position, lift the board and move it to the horizontal position. Once the board is horizontal, insert the forward-facing nubs into the hooks on either side.

For the short wheelbase, raise the second panel toward the front of the vehicle when you have the seats folded down.

For the long wheelbase, raise the second panel toward the front of the vehicle.

Note: Before moving the board into the shelf position, you may need to flip down the hooks.

Note: Do not put more than 35 lb (15 kg) on the shelf.

Luggage Compartment

Rear Barrier (Bulkhead Position)



To move the board into the rear barrier or bulkhead position, lift the board and move it to the vertical position. Once the board is vertical, insert the rearward facing nubs into the hooks on either side.

Note: Before moving the board into the rear barrier or bulkhead position, you may need to flip down the hooks.

LUGGAGE COMPARTMENT ANCHOR POINTS

LUGGAGE COMPARTMENT ANCHOR POINT PRECAUTIONS



WARNING: Make sure that you properly secure objects in the luggage compartment. Failure to follow this instruction could result in personal injury in the event of a sudden stop or crash.

Connecting a Trailer

CONNECTING A TRAILER PRECAUTIONS

Do not tow a trailer until you drive your vehicle at least 1,000 mi (1,600 km).

Consult your local motor vehicle laws for towing a trailer.

See the instructions included with towing accessories for the proper installation and adjustment specifications.

Service your vehicle more frequently if you tow a trailer. See **Scheduled Maintenance** (page 490).

If you use a rental trailer, follow the instructions the rental agency gives you.

When attaching the trailer wiring connector to your vehicle, only use a proper fitting connector that works with the vehicle and trailer functions.

Account for the trailer coupler weight as part of your vehicle load when calculating the total vehicle weight.

Do not exceed the load limits. See **Calculating the Load Limit** (page 323).

HITCHES

INSTALLING A HITCH



WARNING: Do not cut, drill, weld or modify the trailer hitch. Modifying the trailer hitch could reduce the hitch rating.

Do not use a hitch that either clamps onto the bumper or attaches to the axle. You must distribute the load in your trailer so that 10-15% of the total weight of the trailer is on the tongue. Do not exceed the tongue load rating indicated on the hitch receiver.

Trailer Hitch Cover

Your vehicle has a removable trailer hitch cover. To remove the trailer hitch cover:

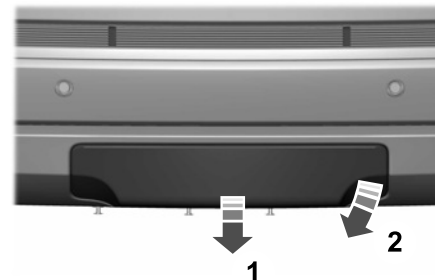

1. Grab the trailer hitch cover at the bottom and pull towards the rear of the vehicle until the bottom of the trailer hitch cover unsnaps from the bumper.
2. Grab the trailer hitch cover at the edge and rotate until the top of the trailer hitch cover unsnaps from the bumper, then remove the trailer hitch cover.

To install the trailer hitch cover:

Connecting a Trailer

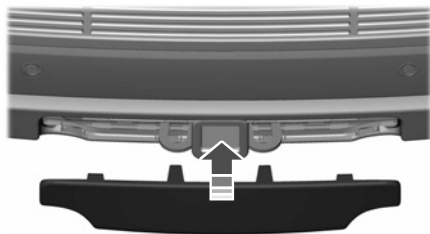

HOOKING UP A TRAILER USING A WEIGHT-DISTRIBUTING HITCH

WARNING: Do not adjust the spring bars so that your vehicle's rear bumper is higher than before attaching the trailer. Doing so will defeat the function of the weight-distributing hitch, which may cause unpredictable handling, and could result in serious personal injury.

A weight-distributing hitch helps distribute tongue load to all towing vehicle and trailer wheels. For more information, visit the links in the following table.

1. Line up the snaps on the trailer hitch cover to the holes on the bumper and push forward until it snaps into place.

Market	Website
United States of America	https://www.fordpro.com/en-us/fleet-vehicles/manuals-and-guides/
Canada (English)	https://www.fordpro.ca/en-ca/fleet-vehicles/manuals-and-guides/
Canada (French)	https://www.fordpro.ca/fr-ca/fleet-vehicles/manuals-and-guides/

Connecting a Trailer

CONNECTING A TRAILER

Recognizing a Trailer

1. Attach the trailer and wiring connector to your vehicle.
2. Switch on your vehicle.
3. Set up a profile for the trailer using the touchscreen.

Note: If your vehicle does not recognize the trailer, press and hold the brake pedal for a few seconds.

Note: Trailer profiles store trailer types, dimensions, preferences, trailer specific mileage and fuel economy.

Note: Disabling the trailer detection notification makes the default trailer profile active when a connection is detected.

Note: Trailer profiles allows you to setup several trailer maintenance reminders and maintenance intervals for multiple trailer components by specifying miles and months in service.



When attaching the trailer wiring connector to your vehicle, only use a proper fitting connector that works with the vehicle and trailer functions.

Trailer Light Check

 **WARNING:** Never connect any trailer lamp wiring to the vehicle's tail lamp wiring; this may damage the electrical system resulting in fire. Contact your authorized dealer as soon as possible for assistance in proper trailer tow wiring installation. Additional electrical equipment may be required.

Most towed vehicles require trailer lamps. Make sure all running lights, brake lights, turn signals and hazard lights are working.

Safety Chains

Install trailer safety chains to the trailer hitch as recommended by the manufacturer. Cross the chains under the trailer coupler and allow enough slack for turning tight corners. Do not allow the chains to drag on the ground.

Note: Do not attach safety chains to the bumper. Always connect the safety chains to the frame or hook retainers of your trailer hitch.

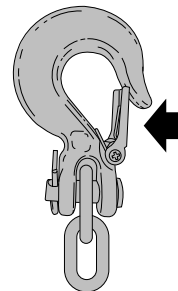

If the trailer safety chain hook has a latch, make sure to fully close the latch.

Connecting a Trailer

TRAILER LIGHTING CHECK



WARNING: Never connect any trailer lamp wiring to the vehicle's tail lamp wiring; this may damage the electrical system resulting in fire. Contact your authorized dealer as soon as possible for assistance in proper trailer tow wiring installation. Additional electrical equipment may be required.

Perform a trailer light illumination sequence to confirm that all lights are functioning by using the Ford mobile app or the vehicle's touchscreen.

Note: *The Ford mobile app allows one person to confirm that all lights are functioning.*

Performing the Trailer Lighting Check Using the Touchscreen

1. Open the towing app using the app launcher. See **Apps** (page 470).
2. Open the towing settings.
3. Press **Trailer Light Check**.
4. Press **Start**.

TRAILER BATTERY CHARGE/ TRAILER POWER FEED

This feature allows the trailer's battery to charge under the following situations:

- Your vehicle is in the accessory or engine run position
- If the vehicle's battery voltage is in optimum condition, above 12.5 volts, and the trailer's battery can still hold a charge, or is not too old.

Note: *The trailer battery charge status appears in the instrument cluster display. See **Instrument Cluster** (page 124).*

The trailer power feed feature allows for a 12 volt power output on a 7-pin connector when the system detects a trailer.

Note: *Trailer power feed can provide a maximum output rate of 15 amps.*

Note: *Never place more demand than 15 amps of power on the trailer power feed, this may damage the trailer lighting.*

Connecting a Trailer

CONNECTING A TRAILER – TROUBLESHOOTING

CONNECTING A TRAILER – INFORMATION MESSAGES

Message	Details
Trailer Disconnected	The system senses a trailer connection becomes disconnected, either intentionally or unintentionally, during a given ignition cycle.
Trailer Wiring Fault	There are certain faults in the vehicle wiring, trailer wiring or brake system.
Trailer Battery Not Charging See Manual	The vehicle battery voltage is low, there is a fault with the trailer battery or the trailer battery voltage is below 8 V.
Trailer Tire Low Specified:	One or more tires on your trailer is below the specified tire pressure.
Trailer Tire Over Temperature	Displays when one or more tires on the trailer is above the recommended temperature.
Trailer Tire Pressure Sensor Fault	A trailer tire pressure sensor is malfunctioning. If the warning stays on or continues to come on, have the system checked as soon as possible.
Trailer Tire Pressure Monitor Fault	The trailer tire pressure monitoring system is malfunctioning. If the warning stays on or continues to come on, have the system checked as soon as possible.
Trailer Tire Pressure Monitor Capability Not Detected	The system cannot detect the trailer tire pressure monitoring system.
Trailer Tire Pressure Indication Not Setup See Manual	The trailer tire pressure monitoring system is not setup.

Towing a Trailer

TOWING A TRAILER PRECAUTIONS

 **WARNING:** Do not exceed the GVWR or the GAWR specified on the certification label.

 **WARNING:** Towing trailers beyond the maximum recommended gross trailer weight exceeds the limit of your vehicle and could result in engine damage, transmission damage, structural damage, loss of vehicle control, vehicle rollover and personal injury.

 **WARNING:** Do not exceed the lowest rating capacity for your vehicle or trailer hitch. Overloading your vehicle or trailer hitch can impair your vehicle stability and handling. Failure to follow this instruction could result in the loss of control of your vehicle, personal injury or death.

 **WARNING:** Make sure that the vertical load on the tow ball is between the minimum and maximum recommended weight at all times. Failure to follow this instruction could result in the loss of control of your vehicle, personal injury or death.

 **WARNING:** Do not cut, drill, weld or modify the trailer hitch. Modifying the trailer hitch could reduce the hitch rating.

 **WARNING:** The anti-lock brake system does not control the trailer brakes.

TRAILER BRAKE PRECAUTIONS

 **WARNING:** Do not connect a trailer's hydraulic brake system directly to your vehicle's brake system. Your vehicle may not have enough braking power and your chances of having a collision greatly increase.

 **WARNING:** Do not tow a trailer fitted with electric trailer brakes unless your vehicle is fitted with a compatible aftermarket electronic trailer brake controller. Failure to follow this instruction could result in the loss of control of your vehicle, personal injury or death. For additional information and assistance, we recommend that you contact an authorized dealer.

Electric brakes and manual, automatic or surge-type trailer brakes are safe if you install them properly and adjust them to the manufacturer's specifications. The trailer brakes must meet local and federal regulations.

Towing a Trailer

The rating for the tow vehicle's braking system operation is at the gross vehicle weight rating, not the gross combined weight rating.

Certain states require functioning trailer brakes for trailers over a specified weight. Be sure to check state regulations for this specified weight.

Ford Motor Company recommends separate functioning brake systems for trailers weighing more than 1,500 lb (680 kg) when loaded.

TOWING A TRAILER LIMITATIONS

The vehicle's load capacity designation is by weight, not by volume, so you cannot necessarily use all available space when loading a vehicle or trailer.

Towing a trailer also depends on additional systems present in your vehicle. See **Lane Centering Precautions** (page 263). See **BlueCruise Precautions** (page 271). See **Adaptive Cruise Control Precautions** (page 255).

Note: *Your vehicle could have reduced performance when operating at high altitudes and when heavily loaded or towing a trailer. When driving at elevation, to match driving performance as perceived at sea level, reduce gross vehicle weight and gross combination weight by 2% per 1,000 ft (300 m) elevation.*

LOADING YOUR TRAILER

To help minimize how trailer movement affects your vehicle when driving:

- Load the heaviest items closest to the trailer floor.
- Load the heaviest items centered between the left and right side trailer tires.

- Load the heaviest items above the trailer axles or just slightly forward toward the trailer tongue. Do not allow the final trailer tongue weight to go above or below 10-15% of the loaded trailer weight. The trailer tongue weight should never exceed 10% of the maximum towing capacity.
- Select a ball mount with the correct rise or drop. When both the loaded vehicle and trailer are connected, the trailer frame should be level, or slightly angled down toward your vehicle, when viewed from the side.

TRAILER TOWING HINTS

Towing a trailer places an extra load on your vehicle's engine, transmission, axle, brakes, tires and suspension. Periodically inspect these components during and after any towing operation.

When driving with a trailer or payload, a slight takeoff vibration or shudder may be present due to the increased payload weight.

Towing a Trailer

Your vehicle may have a temporary or conventional spare tire. A temporary spare tire is different in diameter or width, tread-type, or is from a different manufacturer than the road tires on your vehicle. Consult information on the tire label or Safety Compliance label for limitations when using.

When towing a trailer:

- Obey country specific regulations for towing a trailer.
- Do not drive faster than 70 mph (113 km/h) during the first 500 mi (800 km).
- Do not make full-throttle starts.
- Check your hitch, electrical connections and trailer wheel lug nuts thoroughly after you have traveled 50 mi (80 km).
- When stopped in congested or heavy traffic during hot weather, place the transmission in park (P) to aid engine and transmission cooling and to help A/C performance.
- Turn off the speed control with heavy loads or in hilly terrain. The speed control may turn off when you are towing on long, steep slopes.

- Shift to a lower gear when driving down a long or steep hill. Do not continuously apply the brakes, as they may overheat and become less effective.
- If your transmission has Grade Assist or Tow/Haul, use this feature when towing. This provides engine braking and helps eliminate excessive transmission shifting for optimum fuel economy and transmission cooling.
- Your vehicle has AdvanceTrac with roll stability control. When towing a trailer, additional loads could cause the AdvanceTrac system to engage during cornering maneuvers. Reduce cornering speeds to make sure that you can maintain control of the vehicle and trailer if the AdvanceTrac system engages.
- Allow more distance for stopping with a trailer attached. Anticipate stops and gradually brake.
- Avoid parking on a slope. However, if you must park on a slope, turn the steering wheel to point your vehicle tires away from traffic flow, set the parking brake, place the transmission in park (P) and place wheel chocks in front and back of the trailer wheels.

Note: Chocks are not included with your vehicle.

LAUNCHING OR RETRIEVING A BOAT OR PERSONAL WATERCRAFT

When backing down a ramp during boat launching or retrieval:

- Do not allow the static water level to rise above the bottom edge of the rear bumper.
- Do not allow waves to break higher than 6 in (15 cm) above the bottom edge of the rear bumper.

Exceeding 6 in (15 cm) could allow water to enter vehicle components, causing internal damage to the components and affecting driveability, emissions and reliability.

Note: Replace the rear axle lubricant anytime the rear axle has been submerged in water.

Note: Disconnect the trailer wiring connector before backing the trailer into the water.

Note: Reconnect the trailer wiring connector after removing the trailer from the water.

Towing a Trailer

TOWING WEIGHTS AND DIMENSIONS

RECOMMENDED TOWING WEIGHTS

Market	Website
United States of America	https://www.fordpro.com/en-us/fleet-vehicles/manuals-and-guides/
Canada (English)	https://www.fordpro.ca/en-ca/fleet-vehicles/manuals-and-guides/
Canada (French)	https://www.fordpro.ca/fr-ca/fleet-vehicles/manuals-and-guides/

Towing a Trailer

WHAT IS THE MAXIMUM LOADED TRAILER WEIGHT

The maximum loaded trailer weight is the highest possible weight of a fully loaded trailer the vehicle can tow.

CALCULATING THE MAXIMUM LOADED TRAILER WEIGHT FOR YOUR VEHICLE

1. Start with the gross combined weight rating for your vehicle model and axle ratio.
2. Subtract all of the following that apply to your vehicle:

- Vehicle curb weight.
- Hitch hardware weight, for example a draw bar, ball, locks or weight distributing hardware.
- Driver weight.
- Passenger weight.
- Payload, cargo and luggage weight.
- Aftermarket equipment weight.

This equals the maximum loaded trailer weight for this combination.

Note: *The trailer tongue load is considered part of the payload for your vehicle. Reduce the total payload by the final trailer tongue weight.*

Note: *Consult an authorized dealer to determine the maximum trailer weight allowed for your vehicle if you are not sure.*

Towing a Trailer

TOWING A TRAILER – TROUBLESHOOTING

TOWING A TRAILER – INFORMATION MESSAGES

Message	Details
Trailer Left Turn Lamps Fault Check Lamps	The left-hand trailer turn lamp requires service.
Trailer Right Turn Lamps Fault Check Lamps	The right-hand trailer turn lamp requires service.
Trailer Battery Not Charging See Manual	The vehicle battery voltage is low, there is a fault with the trailer battery or the trailer battery voltage is below 8 V.
Trailer Lighting Module Fault See Manual	The system detects a short created by the trailer lamps. Inspect and repair the trailer wiring, or have the system checked as soon as possible.
Trailer Stop Lamps Fault Check Lamps	The trailer stoplamps require service.
Trailer brake system fault See manual	Verify the trailer brake connections are secure and that the aftermarket trailer brake controller device is correctly installed. Perform a trailer brake and trailer light check if possible. If the message persists, have your vehicle checked as soon as possible.
Trailer brake module fault	Perform a trailer brake and trailer light check if possible. If the message persists, have your vehicle checked as soon as possible.
Trailer Sway Reduce Speed	The trailer sway control detects trailer sway. Reduce the vehicle's speed.
Trailer Tire Over Temperature	Displays when one or more tires on the trailer is above the recommended temperature.
Trailer Tire Low Specified:	One or more tires on your trailer is below the specified tire pressure.

Towing a Trailer

Message	Details
Trailer Tire Pressure Sensor Fault	A trailer tire pressure sensor requires service. If the warning stays on or continues to come on, have the system checked as soon as possible.
Trailer Tire Pressure Monitor Fault	The trailer tire pressure monitoring system requires service. If the warning stays on or continues to come on, have the system checked as soon as possible.
Trailer Tire Pressure Monitor Capability Not Detected	The system cannot detect the trailer tire pressure monitoring system.
Trailer Tire Pressure Indication Not Setup See Manual	The trailer tire pressure monitoring system is not setup.

Integrated Trailer Brake Controller (If Equipped)

WHAT IS THE INTEGRATED TRAILER BRAKE CONTROLLER

The trailer brake controller assists in smooth and effective trailer braking based on the towing vehicle's brake pressure.

INTEGRATED TRAILER BRAKE CONTROLLER PRECAUTIONS



WARNING: Use the integrated trailer brake controller to properly adjust the trailer brakes and check all connections before towing a trailer. Failure to follow this instruction could result in the loss of control of your vehicle, personal injury or death.

- Only use the manual control lever for proper adjustment of the gain during trailer setup. Misuse, such as application during trailer sway, could cause instability of trailer or tow vehicle.
- Avoid towing in adverse weather conditions. The trailer brake controller does not provide anti-lock control of the trailer wheels. Trailer wheels can lock up on slippery surfaces, resulting in reduced stability of trailer and tow vehicle.
- The trailer brake controller is only a factory-installed or dealer-installed item. Ford is not responsible for warranty or performance of the controller due to misuse or customer installation.

Note: Do not attempt removal of the trailer brake controller without consulting the Workshop Manual. Damage to the unit may result.

Note: Make sure to set the integrated trailer brake controller gain to 0 if you are using an aftermarket trailer brake controller.

USING THE INTEGRATED TRAILER BRAKE CONTROLLER

1. Make sure the trailer brakes are in good working condition, functioning normally and properly adjusted. See your trailer dealer if necessary.

Note: An authorized dealer can diagnose the trailer brake controller to determine exactly which trailer fault has occurred. Your vehicle warranty does not cover issues with your trailer.

2. Hook up the trailer and make the electrical connections according to the trailer manufacturer's instructions.

Note: Select default mode if the trailer has surge brakes, or no brakes at all. The system has no effect on the braking performance of the trailer in either of these cases.

Note: If a trailer is connected by a four-pin connector, the trailer braking function will not be supported.

3. When you plug in a trailer with electric or electric-over-hydraulic brakes, a message confirming connection appears in the information display.

Integrated Trailer Brake Controller (If Equipped)

- Use the gain adjustment to find the desired starting point. A gain setting of 6.0 is a good starting point for heavier loads.

Note: Use the following steps to adjust the gain setting whenever road, weather and trailer, or vehicle loading conditions, change from when you initially set the gain.

- In a traffic-free environment, tow the trailer on a dry, level surface and squeeze the manual control lever completely.
- If the trailer wheels lock up, indicated by squealing tires, reduce the gain setting. If the trailer wheels turn freely, increase the gain setting. Repeat Steps 5 and 6 until the gain setting is at a point just below trailer wheel lock-up. If towing a heavier trailer, trailer wheel lock-up may not be attainable even with the maximum gain setting of 10.

Note: Only perform this procedure at speeds of approximately 20–25 mph (30–40 km/h).

Note: The trailer brake controller reduces output at vehicle speeds below 11 mph (18 km/h) so that trailer and vehicle braking is not jerky or harsh. This feature is only available when applying the brakes using your vehicle's brake pedal, not the controller.

Note: Your vehicle's brake system and the trailer brake system work independently of each other. Changing the gain setting on the controller does not affect the operation of your vehicle's brakes whether you attach a trailer or not.

Note: With the proper electrical connection, pressing your vehicle brake pedal or using the manual control lever illuminates both trailer and vehicle brake lamps.

Note: When you switch the engine off, the controller output is disabled and the display and module shut down. The controller module and display turn on when you switch the ignition on.

Adjusting the Trailer Brake Gain

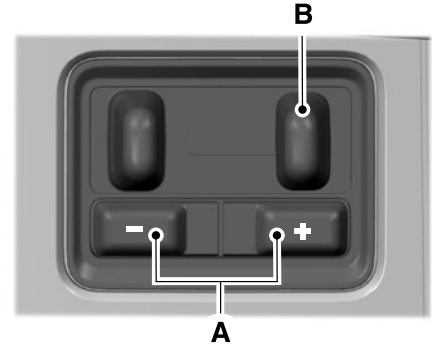

- A Increase or decrease the amount of gain in set increments.
- B Slide the control to engage the trailer control.

Note: Adjust gain setting before using the trailer brake controller for the first time.

Note: The gain should be set to provide the maximum trailer braking assistance while making sure the trailer wheels do not lock when using the brakes. Locked trailer wheels may lead to trailer instability.

Integrated Trailer Brake Controller (If Equipped)

Note: Setting adjustments are saved when a trailer profile is selected.

ADJUSTING THE INTEGRATED TRAILER BRAKE CONTROLLER MODE

Select the correct integrated trailer brake controller mode option using the touchscreen.

Note: Trailer brake gain settings are saved to the active trailer profile.

Selecting the Trailer Brake Type

1. Press **Default** for trailers with electromagnetic drum brake systems or press **Electric over Hydraulic** for trailers with electrically actuated hydraulic brake systems.
2. Press **Save**.

Selecting the Trailer Brake Effort

1. Select a setting for your trailer.

Note: The default value is **Low** and is the recommended setting for most trailers. Select a different setting if your trailer's brakes require more initial voltage, or you prefer more aggressive trailer braking.

2. Press **Save**.

Integrated Trailer Brake Controller (If Equipped)

INTEGRATED TRAILER BRAKE CONTROLLER – TROUBLESHOOTING

INTEGRATED TRAILER BRAKE CONTROLLER – INFORMATION MESSAGES

Message	Action
Trailer Connected	The system detects a correct trailer connection during a given ignition cycle.
Trailer Disconnected	The system detects the trailer wiring connection is disconnected, during a given ignition cycle.
Trailer Wiring Fault	The system detects an electrical fault in the trailer brake circuit. If this message appears without a trailer attached, see your authorized dealer. If a trailer is attached, inspect and repair the trailer wiring.
Trailer Brake Gain: {trailer gain value:#0.0}	Displays the current gain setting for the trailer brake.
Trailer Brake Gain: {trailer gain value:#0.0} No Trailer	Displays the current gain setting for the trailer brake when you do not have a trailer connected.

Integrated Trailer Brake Controller (If Equipped)

INTEGRATED TRAILER BRAKE CONTROLLER – FREQUENTLY ASKED QUESTIONS

How do I determine if there is an issue with the wiring on my vehicle?

- A message displays accompanied by a single tone, when no trailer is connected. This indicates that the issue is between the trailer brake controller and the 7-pin connector at the bumper.

How do I determine if there is an issue with the wiring on my trailer?

- A message only displays with a trailer connected. Consult your trailer dealer for assistance.

Trailer Sway Control

HOW DOES TRAILER SWAY CONTROL WORK

The system applies the brakes to the individual wheels and reduces engine torque to aid vehicle stability.

If the trailer begins to sway, the stability control lamp flashes and the message **Trailer Sway Reduce Speed** appears in the information display.

Stop your vehicle as soon as it is safe to do so. Check the vertical weight on the tow ball and trailer load distribution.

TRAILER SWAY CONTROL PRECAUTIONS



WARNING: Turning off trailer sway control increases the risk of loss of vehicle control, serious injury or death. Ford does not recommend disabling this feature except in situations where speed reduction may be detrimental (such as hill climbing), the driver has significant trailer towing experience, and can control trailer sway and maintain safe operation.

Note: This feature only activates when significant trailer sway occurs.

Note: This feature does not prevent trailer sway, but reduces it once it begins.

Note: This feature cannot stop all trailers from swaying.

Note: In some cases, if vehicle speed is too high, the system may activate multiple times, gradually reducing vehicle speed.

SWITCHING TRAILER SWAY CONTROL ON AND OFF

1. From the settings menu, press Towing.
2. Press settings.
3. Switch Trailer Sway Control.

The system turns on each time you start your vehicle.

Trailer Hitching Assistance

WHAT IS TRAILER HITCHING ASSISTANCE

Trailer hitching assistance helps the driver align the vehicle hitch ball to a trailer coupler.

HOW DOES TRAILER HITCHING ASSISTANCE WORK

Trailer hitching assistance uses the following to detect your trailer:

- Rear view camera.
- Radar.
- Parking aid sensors.
- External rear lighting.

This feature also controls the following to align the hitch ball with the trailer coupler:

- Steering.
- Shifting.
- Braking and acceleration.

Note: Blocked sensors could affect system performance. Do not cover the sensors with bumper stickers, tape, repair compound or other objects.

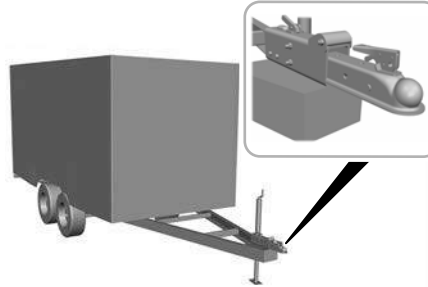

TRAILER HITCHING ASSISTANCE PRECAUTIONS

WARNING: You are responsible for controlling your vehicle at all times. The system is designed to be an aid and does not relieve you of your responsibility to drive with due care and attention. Failure to follow this instruction could result in the loss of control of your vehicle, personal injury or death.

WARNING: The system is not designed to detect cyclists, motorcyclists, pedestrians or animals. Apply the brakes when necessary. Failure to follow this instruction could result in personal injury or death.

WARNING: The system may not operate properly during severe weather conditions, for example snow, ice, heavy rain and spray. Always drive with due care and attention. Failure to take care may result in a crash.

Note: Trailer hitching assistance only works with conventional trailers, couplers and hitch balls.

Note: The hitch ball must be properly installed on the vehicle for the system to function as intended. An improperly installed hitch ball could result in damage to your vehicle or trailer.

Note: Certain aftermarket modifications such as oversized tires or lift kits could make trailer hitching assistance fail or not work as intended.

Note: Keep the sensors and camera free from snow, ice and dirt.

Trailer Hitching Assistance

Note: Clean the camera lens with a soft, lint-free cloth and non-abrasive cleaner.

TRAILER HITCHING ASSISTANCE LIMITATIONS

The system could not function, or could function with reduced performance, during the following:

- When using trailer hitching assistance in tall grass and weeds.
- When safety chains, cables or wiring are dangling near the coupler.
- When using trailer hitching assistance on slippery surfaces.
- When using hitches that raise the hitch ball more than 4 in (10 cm), lower the hitch ball by more than 6 in (16 cm) or extend the hitch ball away from the vehicle more than 12 in (30 cm).
- When using hitches that are less than 10 in (25 cm) from the ground.
- When using objects taller than 8 in (20 cm), such as large blocks under the jack stand.

- When you park the trailer on surfaces that are similar in color to the trailer coupler and hitch ball.
 - A black coupler or hitch ball over a dark asphalt surface.
 - A light color coupler or hitch ball over a light concrete surface.
- When there are low or no light sources, such as at night.
- The system may not work accurately during cold weather conditions. If this occurs, allow the vehicle to reach optimal temperature to resume operation.

For additional information, refer to the Ford Support website.

SWITCHING TRAILER HITCHING ASSISTANCE ON AND OFF

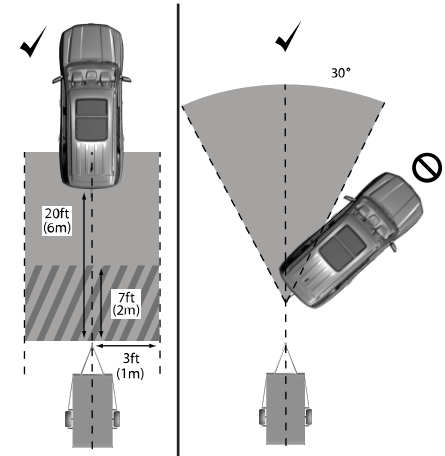

Press the button to switch the system on and off. You can also switch the system off through the touchscreen.

Trailer Hitching Assistance

USING TRAILER HITCHING ASSISTANCE

Before switching on the system, make sure that your vehicle:

- Is within 20 ft (6 m) of the trailer and no closer than 7 ft (2 m).
- Is less than a 30° approach angle to the trailer.
- Is within 3 ft (1 m) of the front of the trailer facing the same direction.
- Is clear of obstacles or other vehicles within 6 ft (1.8 m) on either side of your vehicle or the trailer.
- Has the liftgate in the fully closed position.
- Has radar, sensor, and camera free from snow, ice and dirt.
- Has parking aid sensors switched on in the touchscreen.

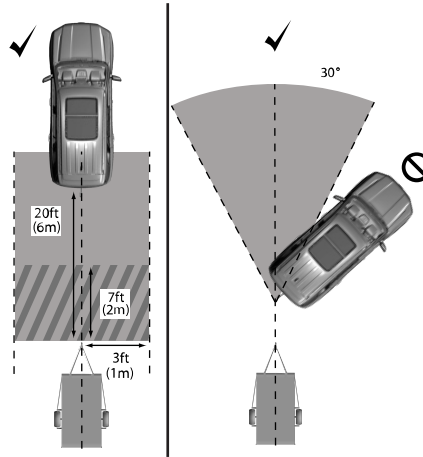

1. Press the Pro Trailer button.

Note: Press the Pro Trailer button to switch the system on and off.

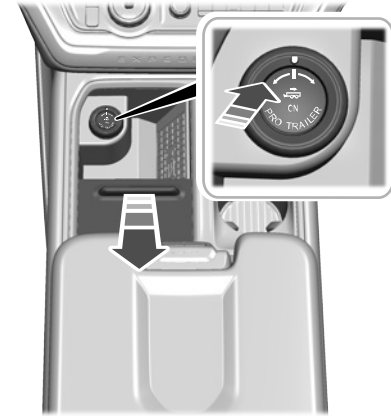

2. Select when asked, Is a trailer connected on the touchscreen to activate the system.
3. Follow the instructions on the touchscreen.

Note: Pressing the Pro Trailer button other than when prompted turns off the system.

Trailer Hitching Assistance

TRAILER HITCHING ASSISTANCE INDICATORS



The white indicator represents the system searching for the trailer. Continue moving the vehicle until the trailer coupler is inside this indicator. The indicator turns green once the trailer coupler is in the correct position.



The bracket shows you the estimated location of your trailer.



The yellow indicator represents that you have positioned your vehicle too close to the trailer and you need to pull away from the trailer until the indicator turns green.

Trailer Hitching Assistance Audible Indicators

A tone sounds as part of normal operation of the system to alert the driver that an action needs to be taken or an event has been completed.

Trailer Backup Assistance (If Equipped)

WHAT IS TRAILER BACKUP ASSISTANCE

Trailer backup assistance utilizes the control knob on the instrument panel to help you steer a trailer. Turn the control knob in the direction you want the trailer to go and the system steers the vehicle.

HOW DOES TRAILER BACKUP ASSISTANCE WORK

Trailer backup assistance uses a sticker to detect the trailer angle relative to the towing vehicle and provides instructions, graphics and camera views on the touchscreen.

TRAILER BACKUP ASSISTANCE PRECAUTIONS



WARNING: Driving while distracted can result in loss of vehicle control, crash and injury. We strongly recommend that you use extreme caution when using any device that may take your focus off the road. Your primary responsibility is the safe operation of your vehicle. We recommend

against the use of any hand-held device while driving and encourage the use of voice-operated systems when possible. Make sure you are aware of all applicable local laws that may affect the use of electronic devices while driving.



WARNING: This system does not automatically brake your vehicle. This system is an extra driving aid. It does not replace your attention and judgment, or the need to apply the brakes. If you do not apply the brakes when necessary, you may collide with another vehicle or other objects.

Note: *The system is not a substitute for safe driving practices. Always be aware of your vehicle and trailer combination, and the surrounding environment.*

Note: *The system does not detect or prevent your vehicle or trailer from making contact with obstacles in the surrounding environment.*

Note: *The front end of your vehicle swings out when changing the direction of the trailer.*

Note: *In certain conditions, the trailer could turn faster or the trailer angle could increase more than anticipated. Always monitor the clearance between the trailer and vehicle and the surroundings.*

SETTING UP THE TRAILER BACKUP ASSISTANCE FOR A CONVENTIONAL TRAILER

CONFIGURING THE TRAILER

You must configure a trailer in the system to use the trailer reversing aids. This is a one-time setup process per trailer and the trailer information is saved in the system for the next time you use that trailer.

The system only works with conventional trailers. It does not work with other types including fifth-wheel and gooseneck trailers. The following illustration shows examples of conventional trailers on the left-hand side.

Trailer Backup Assistance (If Equipped)

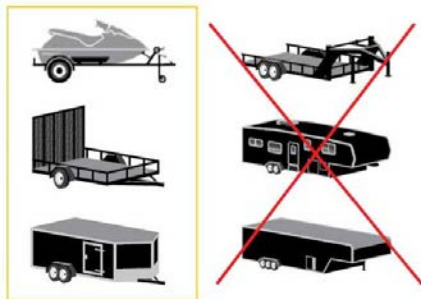

Positioning the Trailer

Hitch the trailer to your vehicle and connect the electrical wiring harness. Check to make sure that the wiring is working.



Park your vehicle and hitched trailer on a level surface.

For best results, make sure that your trailer rides level with the ground when you hitch your vehicle.



Make sure that the trailer and your vehicle are in line with each other. You can do this by putting the transmission in drive (D) and pulling straight forward.

Configuring the Trailer in the Touchscreen

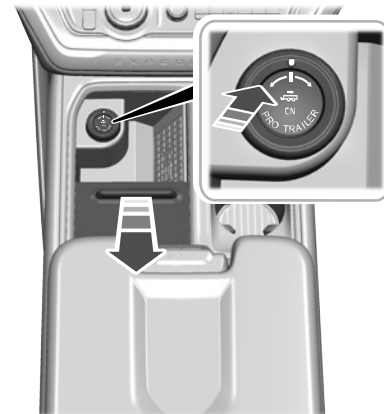

1. Press the button to switch the system on.
2. Press **Add Trailer** on the touchscreen.
3. Follow the directions on the touchscreen to enter the trailer name, then proceed to the sticker setup. See **Applying the Trailer Reversing Aid Sticker** (page 354).

Trailer Backup Assistance (If Equipped)

APPLYING THE TRAILER REVERSING AID STICKER

Place the sticker in an area visible by the rear view camera. The entire sticker must be within 4–19 in (10–48 cm) from the center of the hitch ball, as shown in the following illustration.

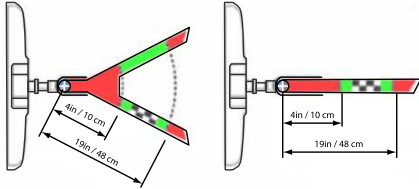

Use the sticker placement card and a tape measure to determine the appropriate area to place the sticker. Make sure the entire sticker is within the green zone between the two arcs or distance markers on the diagram, and is also visible in the rear view camera display.

Once you have found the correct location, place the sticker.

Note: Make sure nothing can obstruct the rear view camera's view of the sticker such as a jack handle or wiring.

Note: Position the sticker on a flat, dry, and clean horizontal surface. For best results, apply the sticker when temperatures are above 32°F (0°C).

Note: Do not move stickers after placing them. Do not reuse any stickers if removed.

Note: You can purchase additional stickers through your authorized dealer.

CALIBRATING THE SYSTEM

Calibrating the system requires driving forward and turning left or right. Follow the instructions on the touchscreen to complete the calibration process.



Note: To calibrate the system, you need an area where you can safely drive forward and turn left or right. An open parking lot is an ideal place to perform the calibration.

Note: Keep the steering wheel straight when instructed to by the touchscreen. If the steering wheel is in a turned position during this instruction, the calibration pauses.

Trailer Backup Assistance (If Equipped)

Note: During calibration, the system determines the trailer length. The system supports trailer lengths of 6–33 ft (1.85–10.05 m) distance from the hitch point to the center of the axle or axles. The system is designed to work with drawbars that have a license plate to hitch ball center measurement of 9–18 in (23–46 cm) when installed. Do not attempt to use drawbars or trailers that have a length outside of this range as the system performance degrades and could cause improper system function.

Note: The touchscreen shows if you are going too slow or fast. Calibration pauses if the speed is outside the required range of 2–9 mph (4–15 km/h).

Note: You need to complete at least a 90° turn, and longer trailers could require a 180° turn. Camera trailer tracking requires the system to locate the hitch ball as well as determine the trailer length. Some trailers could require you to drive straight then turn multiple times before calibration completes. The touchscreen provides instructions and notifies you when calibration completes.

Note: For best results, do not calibrate the system at night when calibrating.

SWITCHING TRAILER BACKUP ASSISTANCE ON AND OFF

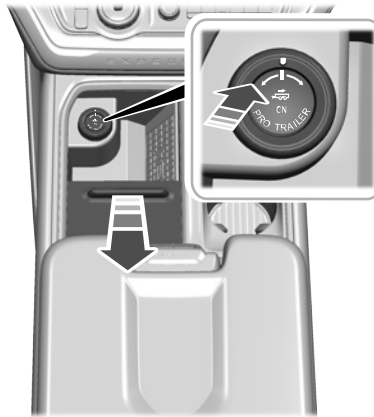

Press the button and use the touchscreen to select the connected trailer.

Note: A trailer must be configured to use trailer backup assistance.

Note: If you use the steering wheel when using trailer backup assistance, the system turns off and a message displays in the touchscreen.

Note: If the trailer was connected just prior to turning the system on, you may need to drive forward to initialize the system. Follow the instructions on the touchscreen to activate the system.

USING THE TRAILER BACKUP ASSISTANCE CONTROLLER

Use the control knob to steer the trailer. Take your hands off the steering wheel and turn the control knob instead. The control knob acts as the steering control for the trailer.

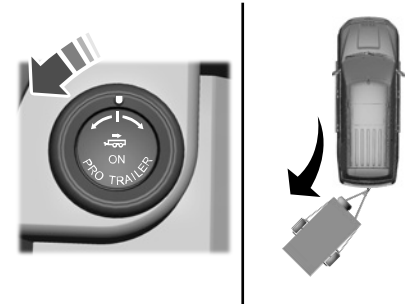

Turn and hold counterclockwise to make the trailer go left.

Trailer Backup Assistance (If Equipped)

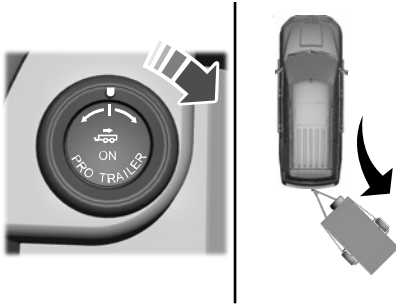

Note: The more you turn the knob, the sharper the trailer turns.

Note: Quickly turning and releasing the knob results in a jerky movement of the vehicle.

Note: You may have to use the knob to correct the trailer direction when attempting to move the trailer straight back under some conditions.

Note: If you want the trailer to turn sharper you can change the trailer angle limit. See **Using the Trailer Backup Assistance Views** (page 356).

USING THE TRAILER BACKUP ASSISTANCE VIEWS

Up to three camera views could be available when using trailer backup assistance. Use the view that helps you the most when reversing your vehicle and trailer.



360° camera view. Shows a 360° view on the right-hand side of the touchscreen with a rear camera view on the left-hand side of the touchscreen.



Rear view camera view. Shows your trailer hitch or what is directly behind your vehicle.



Trailer reverse guidance view. Shows you a view of the sides of your vehicle and the trailer. In auto mode, this view moves as the trailer moves so that you do not have to adjust the camera as you turn. Left and right arrows let you see other camera views.

Auto

Auto. Press to return to auto view.

Note: Auto mode is the default setting.

Hitch Angle Graphic

The hitch angle graphic shows a small representation of your vehicle and trailer with visual feedback to help you monitor the trailer. The graphic shows two different colored lines for the trailer hitch angle. A black line shows you where your trailer is in relation to your vehicle. The white line represents the amount the trailer can turn based on knob input.

The graphic shows a yellow and red zone for the hitch angle to warn you of a high angle condition that could require you to pull forward to reduce the hitch angle. The angle limits for each zone vary based on the trailer length.

Turn and hold clockwise to make the trailer go right.

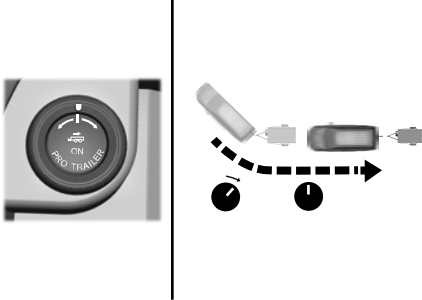

Release the knob when the trailer is moving in the direction you want.

Trailer Backup Assistance (If Equipped)

The yellow zone indicates you are approaching the maximum controllable trailer angle for the system. When the trailer enters this zone, it is more difficult to reduce the trailer turn when backing up. It may be necessary to put your vehicle back into drive (D) and pull forward to get your vehicle and trailer back to an in-line position.

The red zone indicates you have exceeded the maximum controllable trailer angle for the system. Immediately stop reversing. Put your vehicle into drive (D) and pull forward until the trailer is no longer in the red zone.

Setting the Trailer Angle Limit

1. Access the vehicle drawer on the touchscreen.
2. Press **Towing**.
3. Press **Settings**.
4. Press the saved trailer you want to change.
5. Press **Pro Trailer Backup Assist**.
6. Press **Trailer Angle Limit**.
7. Press a setting.

Normal Control Angle

Default setting. This provides a balanced limit that returns from a turn to straight backing with minimal change to the trailer direction.

Max Control Angle

Increases the trailer angle limit close to the maximum controllable angle to allow sharper turns but also causes more change in the trailer direction when straightening out from a turn.

Trailer Backup Assistance (If Equipped)

TRAILER BACKUP ASSISTANCE – TROUBLESHOOTING

TRAILER BACKUP ASSISTANCE – INFORMATION MESSAGES

Message	Description
Detecting Trailer Please Wait...	Displays when the system turns on and is initializing.
Pro Trailer Backup Assist™ System is Not Available	A condition exists that prevents the system from turning on. If the message continues to display, visit your authorized dealer to have your vehicle checked.
Pro Trailer Backup Assist™ Driving Required to Initialize Steering Press Knob to Exit	The steering system needs to learn internal parameters to fully enable the feature. Drive your vehicle straight forward above 25 mph (40 km/h) for approximately 5 minutes.
Pro Trailer Backup Assist™ Stop now Maximum trailer angle Press Knob to Exit	Displays when you reach the maximum controllable trailer angle for the system. Place your vehicle in drive (D) and pull forward to get the truck and trailer back to an in-line position. If this message consistently displays, you may need to repeat the trailer calibration. Delete the trailer from the system and repeat the setup and calibration process.
Stop now. Deactivated by trailer angle.	Displays when you exceed the maximum controllable trailer angle for the system. Place your vehicle in drive (D) and pull forward to get your vehicle and trailer back to an in-line position, then activate the system by selecting the connected trailer and following the instructions on the touchscreen. If this message consistently displays, you may need to repeat the trailer setup and calibration. Delete the trailer from the system and repeat the setup and calibration process.

Trailer Backup Assistance (If Equipped)

Message	Description
Pro Trailer Backup Assist™ Stop Now Take Control of Steering Wheel	Displays when the system can no longer steer the vehicle and you must take over steering.
Pro Trailer Backup Assist™ Trailer Not Detected. Shift to Park Press Knob to Exit	These messages display when the system does not detect the trailer. Make sure the rear camera is clean, and the sticker is clearly visible in the camera image. You can also move the trailer forward or backward to change the trailer position and lighting conditions If these messages continue to display, visit your authorized dealer to have your vehicle checked.
Pro Trailer Backup Assist™ Trailer Not Detected. Refer to Owner's Manual. Press Knob to Exit	
Pro Trailer Backup Assist™ Trailer Not Detected Pull Forward to Initialize Press Knob to Exit	Display when the camera system cannot detect the trailer and requires trailer movement to enable trailer detection. Drive forward above 2 mph (3 km/h) to initialize the system.
Pro Trailer Backup Assist™ Stop Now System Not Active Press Knob to Exit	Displays when your vehicle is backing up but the system is not activated. Select the connected trailer on the touchscreen and follow the instructions to activate the system. This message also displays when you back up during the calibration process.
Pro Trailer Backup Assist™ Backup Slowly Turn Knob to Steer Press Knob to Exit	Displays when the system turns on and is available to use.

Trailer Backup Assistance (If Equipped)

TRAILER BACKUP ASSISTANCE – FREQUENTLY ASKED QUESTIONS

Why does the trailer not reverse straight?

- Verify the sticker is correctly applied. Other factors such as the hitch connection, road camber, road slope and trailer suspension could influence how straight the system can reverse the trailer when the control knob is not turned. You can compensate for the trailer drifting to the right or left by slowly turning the knob until the trailer is following your desired path and holding the knob in that position. Check that the correct trailer is selected in the touchscreen. Verify the sticker is correctly applied and check that the drawbar and the trailer dimensions are within the allowed range. If the trailer consistently does not reverse straight, delete the trailer from the system and repeat the setup process to calibrate the trailer.

What does it mean if the system remains on one message for an extended time during calibration?

- The camera could need to be cleaned, the sticker could be blocked, the drawbar could be outside the allowed range of 9–18 in (23–46 cm) or you could need to move to a different area to change the lighting and background. Verify the sticker is in the proper location. See **Applying the Trailer Reversing Aid Sticker** (page 354). You can move to a different area or change the direction you are driving or set up the system at a different time of day. Some trailers are not compatible with the sticker and camera system.

What does it mean if the system pauses during calibration?

- There could be steering input or trailer movement during the straight drive portion of the calibration process.

What does it mean if the system displays hold steering steady during turn?

- Part of the calibration process for the sticker setup requires a steady turn. If you are continually moving the steering wheel during the turn, this delays the calibration process. To enable the calibration process, hold the steering wheel at the same position when turning.

What does it mean if the system displays that it is not available?

- There could be a sub-system that the system uses that is not correctly operating or there could be a battery voltage issue. If the system continues to display it is not available, visit your authorized dealer to have your vehicle checked.

Trailer Backup Assistance (If Equipped)

What does it mean if the system displays that driving is required to initialize steering?

- The steering system needs to learn internal parameters to fully turn on the feature. Drive your vehicle straight forward above 25 mph (40 km/h) for approximately 5 minutes. This could also occur when your vehicle is new, there is a battery voltage issue or if the steering system has been serviced.

What does it mean if the trailer is at its maximum angle or the system deactivated by trailer angle?

- You are at the maximum controllable trailer angle for the system. Place your vehicle in drive (D) and pull forward to get the truck and trailer back to an in-line position. If this message consistently displays, this could indicate the sticker is incorrectly applied, the trailer needs to be recalibrated or the drawbar or the trailer dimensions are outside of the supported range. The system is designed to work with drawbars that have a license plate to hitch ball center measurement of 9–18 in (23–46 cm) when installed. The system is designed to work with trailers that have a hitch point to center

of the axle or axles measurement of 6–33 ft (1.85–10.05 m). Do not attempt to use drawbars or trailers that have a length outside of this range as the system performance degrades and could cause improper system function. Check that the correct trailer is selected on the touchscreen. Verify the sticker is correctly applied and check that the drawbar and the trailer dimensions are within the allowed range. Then, delete the trailer from the system and repeat the setup process to calibrate the trailer.

What does it mean when the system tells you to take control of the steering wheel?

- The system is no longer steering the vehicle and you must take over steering. There are four reasons the system could display this message. The first reason the system could display this message is that you have touched the steering wheel when the system is steering. The second reason the system could display this message is that you have exceeded the maximum speed for the feature. The third reason the system could display this

message is that the trailer is not detected. The final reason the system could display this message is that an internal condition for system operation is not met that requires your vehicle to return to manual control of the steering.

What does it mean if the system does not detect a trailer?

- The system requires a clear view of the sticker placed on the trailer. You must keep the camera lens and sticker clean for the system to correctly operate. If the system cannot initially detect the trailer, it could be necessary for you to change the lighting conditions by moving your vehicle and trailer or waiting until the conditions change. See **Applying the Trailer Reversing Aid Sticker** (page 354). Some trailers are not compatible with the sticker and camera system.

Note: *The system is designed to be used with the same trailer connection every time you choose the trailer from the touchscreen. When using a different drawbar or a different pinhole on drawbars with more than one, connecting the drawbar to your vehicle affects the trailer position and you may need to repeat the trailer setup and calibration process.*

Trailer Reverse Guidance (If Equipped)

WHAT IS TRAILER REVERSE GUIDANCE

Trailer reverse guidance provides views and graphics on the touchscreen to help you steer your vehicle when you backup a trailer.

HOW DOES TRAILER REVERSE GUIDANCE WORK

Trailer reverse guidance uses a sticker to detect the trailer angle relative to the towing vehicle and provides instructions, graphics and camera views on the touchscreen.

TRAILER REVERSE GUIDANCE PRECAUTIONS



WARNING: Driving while distracted can result in loss of vehicle control, crash and injury. We strongly recommend that you use extreme caution when using any device that may take your focus off the road. Your primary responsibility is the safe operation of your vehicle. We recommend

against the use of any hand-held device while driving and encourage the use of voice-operated systems when possible. Make sure you are aware of all applicable local laws that may affect the use of electronic devices while driving.



WARNING: This system does not automatically brake your vehicle. This system is an extra driving aid. It does not replace your attention and judgment, or the need to apply the brakes. If you do not apply the brakes when necessary, you may collide with another vehicle or other objects.

Note: *The system is not a substitute for safe driving practices. Always be aware of your vehicle and trailer combination, and the surrounding environment.*

Note: *The system does not detect or prevent your vehicle or trailer from making contact with obstacles in the surrounding environment.*

Note: *The front end of your vehicle swings out when changing the direction of the trailer.*

Note: *In certain conditions, the trailer could turn faster or the trailer angle could increase more than anticipated. Always monitor the clearance between the trailer and vehicle and the surroundings.*

SETTING UP TRAILER REVERSE GUIDANCE FOR A CONVENTIONAL TRAILER

CONFIGURING THE TRAILER

You must configure a trailer in the system to use trailer reverse guidance. This is a one-time setup process and the trailer information is saved in the system for the next time you use that trailer.

The system only works with conventional trailers. It does not work with other types including fifth-wheel and gooseneck trailers. The following illustration shows examples of conventional trailers on the left-hand side.

Note: *Trailer reverse guidance camera views are available with no trailer setup. However, complete functionality including graphics and automatic view switching is enabled by setup. Setup is required to enable trailer backup assistance.*

Trailer Reverse Guidance (If Equipped)

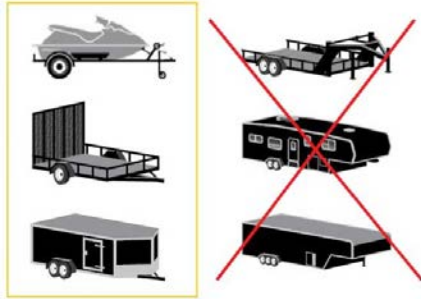

Positioning the Trailer

Hitch the trailer to your vehicle and connect the electrical wiring harness. Check to make sure that the wiring is working. See **Connecting a Trailer** (page 330).



Park your vehicle and hitched trailer on a level surface.

For best results, make sure that your trailer rides level with the ground when you hitch your vehicle. See **Connecting a Trailer** (page 330).



Make sure that the trailer and your vehicle are in line with each other. You can do this by putting the transmission in drive (D) and pulling straight forward.

Configuring the Trailer in the Touchscreen

1. Shift to reverse (R).
2. Press the camera view button.
3. Press the trailer view icon.
4. Press **Add Trailer**.
5. Follow the directions on the touchscreen to enter the trailer name, then proceed to the sticker setup. See **Applying the Trailer Reverse Aid Sticker** (page 363).

APPLYING THE TRAILER REVERSE AID STICKER

Place the sticker in an area visible by the rear view camera. The entire sticker must be within 4–19 in (10–48 cm) from the center of the hitch ball, as shown in the following illustration.

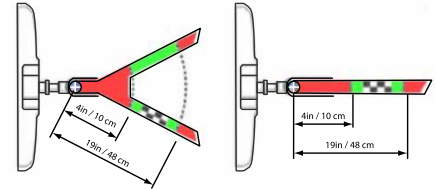

Use the sticker placement card and a tape measure to determine the appropriate area to place the sticker. Make sure the entire sticker is within the green zone between the two arcs or distance markers on the diagram, and is also visible in the rear view camera display.

Once you have found the correct location, place the sticker.

Trailer Reverse Guidance (If Equipped)

Note: Make sure nothing can obstruct the rear view camera's view of the sticker such as a jack handle or wiring.

Note: Position the sticker on a flat, dry, and clean horizontal surface. For best results, apply the sticker when temperatures are above 32°F (0°C).

Note: Do not move stickers after placing them. Do not reuse any stickers if removed.

Note: You can purchase additional stickers through your authorized dealer.

CALIBRATING THE SYSTEM

Calibrating the system requires driving forward and turning left or right. Follow the instructions on the touchscreen to complete the calibration process.



Note: To calibrate the system, you need an area where you can safely drive forward and turn left or right. An open parking lot is an ideal place to perform the calibration.

Note: Keep the steering wheel straight when instructed to by the touchscreen. If the steering wheel is in a turned position during this instruction, the calibration pauses.

Note: During calibration, the system determines the trailer length. The system supports trailer lengths of 6–33 ft (1.85–10.05 m) distance from the hitch point to the center of the axle or axles. The system is designed to work with drawbars that have a license plate to hitch ball center measurement of 9–18 in (23–46 cm) when installed. Do not attempt to use drawbars or trailers that have a length outside of this range as the system performance degrades and could cause improper system function.

Note: The touchscreen shows if you are going too slow or fast. Calibration pauses if the speed is outside the required range of 2–9 mph (4–15 km/h).

Note: You need to complete at least a 90° turn, and longer trailers could require a 180° turn. Camera trailer tracking requires the system to locate the hitch ball as well as determine the trailer length. Some trailers could require you to drive straight then turn multiple times before calibration completes. The touchscreen provides instructions and notifies you when calibration completes.

Note: For best results, do not calibrate the system at night.

Trailer Reverse Guidance (If Equipped)

SWITCHING TRAILER REVERSE GUIDANCE ON AND OFF

Shift into reverse (R), press the rear camera button to expand the menu, press the trailer icon and use the touchscreen to select the connected trailer.

Note: *If the trailer was connected just prior to turning the system on, you may need to drive forward to initialize the system. Follow the instructions on the touchscreen to activate the system.*

USING TRAILER REVERSE GUIDANCE VIEWS

Up to three camera views could be available when using trailer reverse guidance. Use the view that helps you the most when reversing your vehicle and trailer.



360° camera view. Shows a 360° view on the right-hand side of the touchscreen with a rear camera view on the left-hand side of the touchscreen.



Rear view camera view. Shows your trailer hitch or what is directly behind your vehicle.



Trailer reverse guidance view. Shows you a view of the sides of your vehicle and the trailer. In auto mode, this view moves as the trailer moves so that you do not have to adjust the camera as you turn. Left and right arrows let you see other camera views.



Straight backup mode. Shows which way to turn your steering wheel to keep the trailer straight. Use this view when you want to keep your trailer completely in line with your vehicle.

Note: *It may be helpful to shift your vehicle into drive (D), pull forward and straighten out the vehicle and trailer before engaging straight backup mode.*



This takes you back to the 360° camera system and out of the trailer reverse guidance feature.



Auto. Press to return to auto view.

Note: *Auto mode is the default setting.*

Hitch Angle Graphic

The hitch angle graphic shows a small representation of your vehicle and trailer with visual feedback to help you monitor the trailer. The graphic shows two different colored lines for the trailer hitch angle. A black line shows you where your trailer is in relation to your vehicle. The white line represents the amount the trailer can turn based on steering wheel position.

The graphic shows a yellow and red zone for the hitch angle to warn you of a high angle condition that could require you to pull forward to reduce the hitch angle. The angle limits for each zone vary based on the trailer length.

The yellow zone indicates you are approaching the maximum controllable trailer angle for the system. When the trailer enters this zone, it is more difficult to reduce the trailer turn when backing up. It may be necessary to put your vehicle back into drive (D) and pull forward to get your vehicle and trailer back to an in-line position.

The red zone indicates you have exceeded the maximum controllable trailer angle for the system. Immediately stop reversing. Put your vehicle into drive (D) and pull forward until the trailer is no longer in the red zone.

Trailer Reverse Guidance (If Equipped)

TRAILER REVERSE GUIDANCE – TROUBLESHOOTING

TRAILER REVERSE GUIDANCE – INFORMATION MESSAGES

Message	Description
Detecting Trailer Please Wait...	Displays when the system turns on and is initializing.
Trailer Reverse Guidance System is Not Available	A condition exists that prevents the system from turning on. If the message continues to display, visit your authorized dealer to have your vehicle checked.
Trailer Reverse Guidance Driving Required to Initialize Steering Press OK to Exit	The steering system needs to learn internal parameters to fully enable the feature. Drive your vehicle straight forward above 25 mph (40 km/h) for approximately 5 minutes.
Stop now. Deactivated by trailer angle.	Displays when you exceed the maximum controllable trailer angle for the system. Place your vehicle in drive (D) and pull forward to get your vehicle and trailer back to an in-line position, then activate the system by selecting the connected trailer and following the instructions on the touchscreen. If this message consistently displays, you may need to repeat the trailer setup and calibration. Delete the trailer from the system and repeat the setup and calibration process.
Trailer Reverse Guidance Trailer Not Detected. Refer to Owner's Manual. Press OK to Exit	Displays when the system does not detect the trailer. Check that the sticker is correctly applied and the trailer length is within the allowed range. You can also move the trailer forward or backward to change the trailer position and lighting conditions. If these messages continue to display, visit your authorized dealer to have your vehicle checked.

Trailer Reverse Guidance (If Equipped)

Message	Description
Trailer Reverse Guidance Trailer Not Detected Pull Forward to Initialize Press OK to Exit	Displays when your vehicle has not moved after switching on the system or extended operation below 1 mph (1 km/h). Drive forward above 2 mph (3 km/h) to initialize the system.

Trailer Reverse Guidance (If Equipped)

TRAILER REVERSE GUIDANCE – FREQUENTLY ASKED QUESTIONS

What does it mean if the system remains on one message for an extended time during calibration?

- The camera could need to be cleaned, the sticker could be blocked, the drawbar could be outside the allowed range of 9–18 in (23–46 cm) or you could need to move to a different area to change the lighting and background. Verify the sticker is in the proper location. See **Applying the Trailer Reverse Aid Sticker** (page 363). You can move to a different area or change the direction you are driving or setup the system at a different time of day. Some trailers are not compatible with the sticker and camera system.

What does it mean if the system pauses during calibration?

- There could be steering input or trailer movement during the straight drive portion of the calibration process.

What does it mean if the system displays hold steering steady during turn?

- Part of the calibration process for the sticker setup requires a steady turn. If you are continually moving the steering wheel during the turn, this delays the calibration process. To enable the calibration process, hold the steering wheel at the same position when turning.

What does it mean if the system displays that it is not available?

- There could be a sub-system that the system uses that is not correctly operating or there could be a battery voltage issue. If the system continues to display it is not available, visit your authorized dealer to have your vehicle checked.

What does it mean if the system displays that driving is required to initialize steering?

- The steering system needs to learn internal parameters to fully turn on the feature. Drive your vehicle straight forward above 25 mph (40 km/h) for approximately 5 minutes. This could also occur when your vehicle is new, there is a battery voltage issue or if the steering system has been serviced.

What does it mean if the system does not detect a trailer?

- The system requires a clear view of the sticker placed on the trailer. You must keep the camera lens and sticker clean for the system to correctly operate. If the system cannot initially detect the trailer, it could be necessary for you to change the lighting conditions by moving your vehicle and trailer or waiting until the conditions change. See **Applying the Trailer Reverse Aid Sticker** (page 363). Some trailers are not compatible with the sticker and camera system.

Trailer Reverse Guidance (If Equipped)

Note: *The system is designed to be used with the same trailer connection every time you choose the trailer from the touchscreen. When using a different drawbar or a different pin hole on drawbars with more than one, connecting the drawbar to your vehicle affects the trailer position and you may need to repeat the trailer setup and calibration process.*

Driving Hints

BREAKING-IN

Your vehicle requires a break-in period. For the first 1,000 mi (1,600 km), avoid driving at high speeds, heavy braking, aggressive shifting or using your vehicle to tow. During this time, your vehicle may exhibit some unusual driving characteristics.

Note: Do not tow to maximum capacity before 2,500 mi (4,024 km).

DRIVING ECONOMICALLY

The following helps to improve fuel consumption:

- Drive smoothly, accelerate gently and anticipate the road ahead to avoid heavy braking.
- Regularly check your tire pressures and make sure that they are inflated to the correct pressure.
- Follow the recommended maintenance schedule and carry out the recommended checks.
- Plan your journey and check the traffic before you set off. It is more efficient to combine errands into a single trip whenever possible.

- Avoid idling the engine in cold weather or for extended periods. Start the engine only when you are ready to set off.
- Do not carry unnecessary weight in your vehicle as extra weight wastes fuel.
- Do not add unnecessary accessories to the exterior of your vehicle, for example running boards. If you use a roof rack, remember to fold it down or remove it when not in use.
- Do not shift into neutral when you are braking or when your vehicle is slowing down.
- Shut all windows when driving at high speeds.
- Switch off all electric systems when not in use, for example air conditioning. Make sure that you unplug any accessories from the auxiliary power points when not in use.

DRIVING IN COLD WEATHER

The functional operation of some components and systems can be affected at temperatures below approximately -13°F (-25°C).

Driving on Snow and Ice



WARNING: If you are driving in slippery conditions that require tire chains or cables, then it is critical that you drive cautiously. Keep speeds down, allow for longer stopping distances and avoid aggressive steering to reduce the chances of a loss of vehicle control which can lead to serious injury or death. If the rear end of your vehicle slides while cornering, steer in the direction of the slide until you regain control of your vehicle.

On ice and snow, you should drive more slowly than usual. Your vehicle has a four wheel anti-lock brake system, do not pump the brake pedal. See **Anti-Lock Braking System Limitations** (page 212).

In snow and ice, all-wheel drive vehicles have advantages over two-wheel drive vehicles but can still skid. When driving on snowy or icy roads, should you start to slide, turn the steering wheel in the direction of the slide until you regain control.

On snow and ice, avoid suddenly applying power and avoid quick change of direction. Apply the accelerator slowly and steadily when starting from a stop.

Driving Hints

Avoid sudden braking. An all-wheel drive vehicle may accelerate better than a two-wheel drive vehicle in snow and ice. However, an all-wheel drive vehicle will not stop any faster, as braking occurs at all four wheels. Do not become overconfident to road conditions.

DRIVING THROUGH MUD AND WATER

Mud

Be cautious of sudden changes in vehicle speed or direction when you are driving in mud. Even all-wheel drive and four-wheel drive vehicles can lose traction in mud. If your vehicle slides, steer in the direction of the slide until you regain control of your vehicle. After driving through mud, clean off residue stuck to rotating driveshafts and tires. Excess residue can cause an imbalance that could damage drive components.

Note: *If your vehicle gets stuck in mud, it could be rocked out by shifting between forward and reverse gears, stopping between shifts in a steady pattern. Press lightly on the accelerator in each gear.*

Water

If you must drive through water approach it cautiously. See **Driving Through Shallow Water** (page 372).

DRIVING ON HILLY OR SLOPING TERRAIN



WARNING: Extreme care should be used when steering the vehicle in reverse down a slope so as not to cause the vehicle to swerve out of control.

Although natural obstacles could make it necessary to travel diagonally up or down a hill or steep incline, you should try to drive straight up or straight down.

Note: *Avoid turning on steep slopes or hills. A danger lies in losing traction, slipping sideways and possible vehicle rollover. Whenever driving on a hill, determine beforehand the route you can use. Do not drive over the crest of a hill without seeing what conditions are on the other side. Do not drive in reverse over a hill without the aid of an observer.*

Apply just enough power to the wheels to climb the hill. Too much power causes the tires to slip, spin or lose traction, and you could lose control of your vehicle. When descending a steep hill, do not descend the hill in neutral. Avoid sudden hard braking to keep the front wheels rolling and to maintain your vehicle's steering.

Note: *Your vehicle has anti-lock brakes, apply the brakes steadily. Do not pump the brakes.*

DRIVING IN SAND

When driving over sand, try to keep all four wheels on the most solid area of the trail. Steadily drive through the terrain. Apply the accelerator slowly and avoid excessive wheel slip. Do not drive your vehicle in deep sand for an extended period of time. This could overheat the system. A message appears in the instrument cluster display.

Note: *If your vehicle gets stuck in sand, it could be rocked out by shifting between forward and reverse gears, stopping between shifts in a steady pattern. Press lightly on the accelerator pedal in each gear.*

Driving Hints

DRIVING THROUGH SHALLOW WATER

WARNING: Do not attempt to cross a deep or flowing body of water. Failure to follow this instruction could result in the loss of control of your vehicle, personal injury or death.

Note: *Driving through standing water can cause vehicle damage.*

Note: *Engine damage can occur if water enters the air filter.*

Before driving through standing water, check the depth. Never drive through water that is higher than the bottom of the wheel hubs.

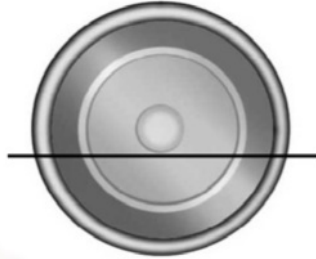

When driving through standing water, drive very slowly and do not stop your vehicle. Your brake performance and traction could be limited. After driving through water and as soon as it is safe to do so:

- Lightly press the brake pedal to dry the brakes and to check that they work.
- Check that the horn works.
- Check that the exterior lights work
- Turn the steering wheel to check that the steering power assist works.

FLOOR MATS

WARNING: Use a floor mat designed to fit the footwell of your vehicle that does not obstruct the pedal area. Failure to follow this instruction could result in the loss of control of your vehicle, personal injury or death.

WARNING: Pedals that cannot move freely can cause loss of vehicle control and increase the risk of serious personal injury.

WARNING: Secure the floor mat to both retention devices so that it cannot slip out of position and interfere with the pedals. Failure to follow this instruction could result in the loss of control of your vehicle, personal injury or death.

WARNING: Do not place additional floor mats or any other covering on top of the original floor mats. This could result in the floor mat interfering with the operation of the pedals. Failure to follow this instruction could result in the loss of control of your vehicle, personal injury or death.

Driving Hints



WARNING: Always make sure that objects cannot fall into the driver foot well while your vehicle is moving. Objects that are loose can become trapped under the pedals causing a loss of vehicle control.



To install floor mats that have eyelets, position the floor mat eyelet over the retention post and press down to lock in position. Repeat for all eyelets on the floor mat.

To remove the floor mats, reverse the installation procedure.

Note: Regularly check the floor mats to make sure they are secure.

Crash and Breakdown Information

ROADSIDE ASSISTANCE

Vehicles Sold in the United States: Getting Roadside Assistance

If you have a vehicle concern, Ford Motor Company offers a complimentary roadside assistance program. This program is separate from the New Vehicle Limited Warranty.

The service is available:

- 24 hours a day, seven days a week.
- For the coverage period supplied with your vehicle.

Knowing your vehicle's VIN, mileage and your specific location allows help to get to you faster.

Roadside Assistance covers:

- A flat tire change with a good spare (except vehicles supplied with a tire inflation kit).
- Battery jump start.
- Lock-out assistance (key replacement cost is the customer's responsibility).

- Fuel delivery — independent service contractors, if not prohibited by state, local or municipal law, shall deliver up to 2 gal (8 L) of gasoline or 5 gal (20 L) of diesel fuel to a disabled vehicle. Roadside assistance limits fuel delivery service to two no-charge occurrences within a 12-month period.
- Winch out — available within 100 ft (30 m) of a paved or county maintained road, no recoveries.
- Towing — independent service contractors, if not prohibited by state, local or municipal law, shall tow Ford eligible vehicles to an authorized dealer within 50 mi (80 km) of the disablement location or to the nearest authorized dealer. If a member requests a tow to an authorized dealer that is more than 50 mi (80 km) from the disablement location, the member shall be responsible for any mileage costs in excess of 50 mi (80 km). Warranty towing, non-warranty towing and collision towing are available.
- Roadside Assistance includes up to \$200 for a towed trailer if the disabled eligible vehicle requires service at the nearest authorized dealer. If the towing vehicle is operational but the trailer is not, then the trailer does not qualify for any roadside services.

Vehicles Sold in the United States: Using Roadside Assistance

United States vehicle customers who require Roadside Assistance, call 1-800-241-3673.

If you need to arrange roadside assistance on your own, Ford Motor Company reimburses a reasonable amount for towing to the nearest dealership within 50 mi (80 km). To obtain reimbursement information, United States vehicle customers call 1-800-241-3673. Customers need to submit their original receipts.

Vehicles Sold in Canada: Getting Roadside Assistance

If you have a vehicle concern, Ford Motor Company of Canada, Limited offers a complimentary roadside assistance program. This program is eligible within Canada or the continental United States.

The service is available 24 hours a day, seven days a week.

Crash and Breakdown Information

This program is separate from the New Vehicle Limited Warranty, but the coverage is concurrent with the powertrain coverage period of your vehicle. Canadian roadside coverage and benefits may differ from the U.S. coverage. For complete details, see your Warranty Guide at www.ford.com/support/warranty/.

Download the Sykes4Ford Roadside Assistance App for access to your roadside assistance services. For more information, scan here:



If you require more information, please call us in Canada at 1-800-665-2006, or visit our website at www.ford.ca.

Ford Motor Company reserves the right to modify or discontinue Roadside Assistance at any time. Certain restrictions apply to Roadside Assistance benefits.

For further details, call
1-800-665-2006 (Canada)
1-800-241-3673 (United States)

SWITCHING THE HAZARD FLASHERS ON AND OFF



The hazard flasher button is on the instrument panel. Press the button to switch the hazard flashers on if your vehicle is creating a safety hazard for other road users.

When you switch the hazard flashers on, all front and rear direction indicators flash.

Note: *The hazard flashers operate when the ignition is in any position, or if the key is not in the ignition. The battery loses charge and could have insufficient power to restart your vehicle.*

Press the button again to switch them off.

JUMP STARTING THE VEHICLE

JUMP STARTING PRECAUTIONS



WARNING: Batteries normally produce explosive gases which can cause personal injury. Therefore, do not allow flames, sparks or lighted substances to come near the battery. When working near the battery, always shield your face and protect your eyes. Always provide correct ventilation.



WARNING: Keep batteries out of reach of children. Batteries contain sulfuric acid. Avoid contact with skin, eyes or clothing. Shield your eyes when working near the battery to protect against possible splashing of acid solution. In case of acid contact with skin or eyes, flush immediately with water for a minimum of 15 minutes and get prompt medical attention. If acid is swallowed, call a physician immediately.





WARNING: Use only adequately sized cables with insulated clamps.

Crash and Breakdown Information

 **WARNING:** Make sure that the cables are clear of any moving parts and fuel delivery system parts.

 **WARNING:** Connect batteries with only the same nominal voltage.

 **WARNING:** Using the jump leads incorrectly or completing the jump start procedure incorrectly can cause the battery to explode, which can lead to severe injuries.

 **WARNING:** All work on the vehicle battery and the electrical system can cause serious chemical burns, fire or electric shocks. Always read the warnings and safety information before carrying out any kind of work on the battery

 **WARNING:** Never charge a 12-volt vehicle battery once it has been frozen. Discharged 12-volt vehicle batteries can even freeze at temperatures of approximately 0°C (+32°F).

 **WARNING:** The battery should be replaced if it is or has ever been frozen.

 **WARNING:** A highly explosive mixture of gases is given off when the vehicle battery is jump started. Always keep fire, sparks, naked flames and lit cigarettes away from the vehicle battery. Never use a mobile telephone when the jump leads are being connected or disconnected.

 **WARNING:** Only charge the battery in a well-ventilated space as the battery emits a highly explosive mixture of gases when the vehicle is being jump started.

 **WARNING:** Never confuse the negative and positive terminals or connect the jump leads incorrectly.

 **WARNING:** Observe the jump lead manufacturer's instructions.

 **WARNING:** If the engine is running while the hood is open, stay clear of moving engine components. Failure to follow this warning could result in serious personal injury or death.

Do not attempt to push-start an automatic transmission vehicle. This could cause transmission damage.

Do not disconnect the battery of the disabled vehicle. This could damage your vehicle's electrical system.

PREPARING THE VEHICLE

Use only a 12 volt supply to start your vehicle. Park the booster vehicle close to the hood of the disabled vehicle, making sure the two vehicles do not touch.

JUMP STARTING THE VEHICLE

Connecting the Jumper Cables

 **WARNING:** Do not connect the negative jumper cable to any other part of your vehicle. Use the ground point.

Note: *If you are using a jump pack or booster box, follow the manufacturer's instructions.*

Crash and Breakdown Information

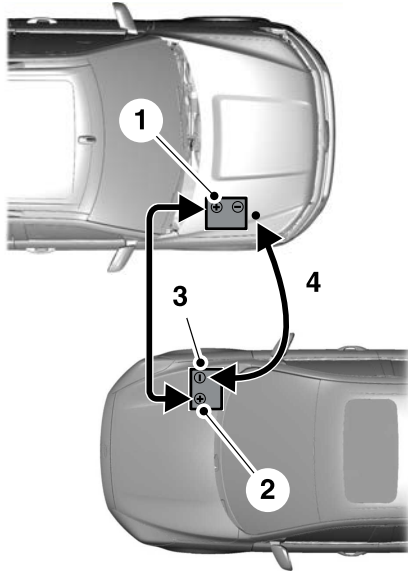

1. Pull the red rubber boot backward. Connect the positive (+) jumper cable to the positive (+) terminal of the discharged battery.

2. Connect the other end of the positive (+) jumper cable to the positive (+) terminal of the booster vehicle battery.
3. Connect the negative (-) jumper cable to the negative (-) terminal of the booster vehicle battery.
4. Make the final connection of the negative (-) jumper cable to an exposed metal part of the disabled vehicle's engine, as shown in the following illustration, away from the battery and fuel injection system, or connect the negative (-) jumper cable to a ground connection point if available.

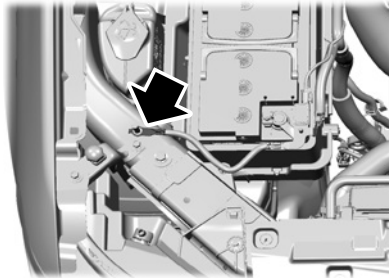

Starting the Engine

1. Start the engine of the booster vehicle and moderately rev the engine, or gently press the accelerator to keep the engine speed between 2000 and 3000 RPM, as shown in your tachometer.
2. Start the engine of the disabled vehicle.
3. Once you start the disabled vehicle, run both vehicle engines for an additional three minutes before disconnecting the jumper cables.

Removing the Jumper Cables

Remove the jumper cables in the reverse order that they were connected.

Note: Do not switch the headlamps on when disconnecting the cables. The peak voltage could blow the bulbs.

POST-CRASH ALERT SYSTEM

WHAT IS THE POST-CRASH ALERT SYSTEM

The system helps draw attention to your vehicle in the event of a serious impact.

Crash and Breakdown Information

HOW DOES THE POST-CRASH ALERT SYSTEM WORK

The system is designed to turn the hazard flashers on, turn the courtesy lamps on, intermittently sound the horn and unlock all doors in the event of a serious impact that deploys an airbag or the seatbelt pretensioners.

POST-CRASH ALERT SYSTEM LIMITATIONS

Depending on applicable laws in the country your vehicle was built for, the horn does not sound in the event of a serious impact.

SWITCHING THE POST-CRASH ALERT SYSTEM OFF

Press the hazard flasher switch, the unlock button on the remote control, the panic button on the remote control or cycle the ignition to switch the system off.

Note: *The alert turns off when the vehicle battery runs out of charge.*

POST-COLLISION BRAKING

How Does Post-Collision Braking Work

In the event of a moderate to severe crash, the braking system reduces the vehicle's speed to prevent or reduce the impact of a potential secondary crash.

Post-Collision Braking Limitations

Post-collision braking does not activate if any of the following occur:

- The anti-lock braking system is damaged during the collision.
- Electronic stability control is disabled.

Overriding Post-Collision Braking

You can override post-collision braking by pressing the brake or accelerator pedal.

Post-Collision Braking Indicators



It flashes when a post-collision braking event is occurring.

AUTOMATIC CRASH SHUTOFF

WHAT IS AUTOMATIC CRASH SHUTOFF

The automatic crash shutoff is designed to stop the fuel going to the engine in the event of a moderate or severe crash.

Note: *Not every impact causes a shutoff.*

AUTOMATIC CRASH SHUTOFF PRECAUTIONS



WARNING: If your vehicle has been involved in a crash, have the fuel system checked. Failure to follow this instruction could result in fire, personal injury or death.

RE-ENABLING YOUR VEHICLE

1. Switch the ignition off.
2. Attempt to start your vehicle.
3. Switch the ignition off.
4. Attempt to start your vehicle.

Note: *If your vehicle does not start after the third attempt, have your vehicle checked as soon as possible.*

Crash and Breakdown Information

RECOVERY TOWING (IF EQUIPPED)

ACCESSING THE FRONT TOWING POINT

 **WARNING:** Using recovery hooks is dangerous and should only be done by a person familiar with proper vehicle recovery safety practices. Improper use of recovery hooks may cause hook failure or separation from the vehicle and could result in serious injury or death.

 **WARNING:** Slowly remove the slack from the recovery strap prior to pulling. Failure to do so can introduce significantly higher loads which can cause the recovery hooks to break off, or the recovery strap to fail which can cause serious injury or death.

 **WARNING:** Never link two straps together with a clevis pin. These heavy metal objects could become projectiles if the strap breaks and can cause serious injury or death.

 **WARNING:** Switch the ignition off before removing the recovery hook. Failure to do so could result in personal injury.

 **WARNING:** The recovery hook can become hot. Let the recovery hook cool down before removing it. Failure to do so could result in personal injury.

Your vehicle has frame-mounted front recovery hooks.

Note: *Do not apply a load to the recovery hooks that is greater than the gross vehicle weight rating of your vehicle.*

Before using recovery hooks:

- Make sure all attaching points are secure and capable of withstanding the applied load.
- Do not use chains, cables or tow straps with metal hook ends.
- Only use recovery straps that have a minimum breaking strength two to three times the gross vehicle weight of the stuck vehicle.
- Make sure the recovery strap is in good condition and free of visible cuts, tears or damage.
- Use a damper device such as a tarp, heavy blanket or piece of carpet, and place it over the recovery strap to help absorb the energy in the event the strap breaks.

- Make sure the stuck vehicle is not loaded heavier than its gross vehicle weight rating specified on the certification label.
- Align the tow vehicle and stuck vehicle in a straight line, within 10 degrees.
- Keep bystanders to the sides of the vehicle, at a distance of at least twice the length of the recovery strap. This helps avoid injury from the hazard of a recovery hook or strap breaking, or a vehicle lurching into their path.

Note: *Use towing equipment that is properly rated for your vehicle. Always carefully follow the instructions and warnings provided by the equipment manufacturer.*

Crash and Breakdown Information

TRANSPORTING THE VEHICLE

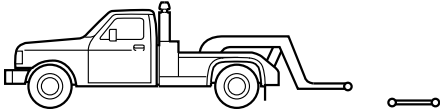

Your manufacturer produces a towing manual for all authorized tow truck operators. Have your tow truck operator refer to this manual for proper hook-up and towing procedures.

We recommend the use of a wheel lift and dollies or flatbed equipment to tow your vehicle. Vehicle damage could occur if towed incorrectly, or by any other means.

Front-wheel and rear-wheel drive vehicles must have their designated drive wheels off the ground regardless of towing direction. Use tow dollies to prevent damage to the transmission.

All-wheel or four-wheel drive vehicles require that all wheels be off the ground using a wheel lift and dollies or flatbed equipment. This prevents damage to the transmission and drive system.

Note: You need to switch on the ignition to unlock the steering.

Note: Make sure you check the steering column before towing. It could lock if the battery is dead.

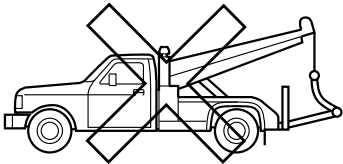
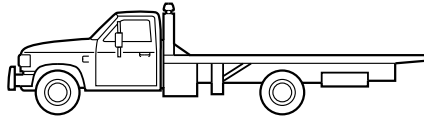

If you need to tow your vehicle, contact a professional towing service or your roadside assistance service provider.

FAIL-SAFE COOLING

WHAT IS FAIL-SAFE COOLING

Fail-safe cooling allows you to temporarily drive your vehicle before any incremental component damage occurs due to overheating.

The fail-safe distance depends on outside temperature, vehicle load and terrain.

HOW DOES FAIL-SAFE COOLING WORK

If the engine reaches a preset over-temperature condition, the engine automatically switches to alternating cylinder operation. Each disabled cylinder acts as an air pump and cools the engine.

When this occurs, your vehicle still operates, however:

- Engine power is limited.
- The air conditioning system turns off.

Continued operation increases the engine temperature, causing the engine to completely shut down. Your steering and braking effort increases in this situation.

Crash and Breakdown Information

When the engine temperature cools, you can re-start the engine.

Note: Have your vehicle checked as soon as possible to minimize engine damage.

DRIVING WHEN FAIL-SAFE MODE IS ACTIVATED



WARNING: Fail-safe mode is for use during emergencies only. Operate your vehicle in fail-safe mode only as long as necessary to bring your vehicle to rest in a safe location and seek immediate repairs. When in fail-safe mode, your vehicle will have limited power, will not be able to maintain high-speed operation, and may completely shut down without warning, potentially losing engine power, power steering assist, and power brake assist, which may increase the possibility of a crash resulting in serious injury.



WARNING: Do not remove the coolant reservoir cap when the engine is on or the cooling system is hot. Wait 10 minutes for the cooling system to cool down. Cover the coolant reservoir cap with a thick cloth to prevent the possibility of scalding and slowly remove the cap. Failure to follow this instruction could result in personal injury.

Continued operation increases the engine temperature, causing the engine to completely shut down. Your steering and braking effort increases in this situation.

When the engine temperature cools, you can re-start the engine. Have your vehicle checked as soon as possible to minimize engine damage.

Your vehicle has limited engine power when in the fail-safe mode, drive your vehicle with caution. Your vehicle does not maintain high-speed operation and the engine may operate poorly.

Remember that the engine is capable of automatically shutting down to prevent engine damage. In this situation:

1. Pull off the road as soon as safely possible and switch the engine off.

2. If you are a member of a roadside assistance program, we recommend that you contact your roadside assistance service provider.
3. If this is not possible, wait for a short period of time for the engine to cool.
4. Check the coolant level. If the coolant level is at or below the minimum mark, add prediluted coolant immediately.
5. When the engine temperature cools, you can re-start the engine. Have your vehicle checked as soon as possible to minimize engine damage.

Note: Driving your vehicle without repair increases the chance of engine damage.

FAIL-SAFE COOLING INDICATORS



If the engine begins to overheat, the coolant temperature gauge moves toward the red zone.



A warning lamp illuminates and a message may appear in the instrument cluster display.

Towing Your Vehicle

TOWING YOUR VEHICLE PRECAUTIONS

Use the following guidelines when towing your vehicle. Failure to follow this instruction could result in vehicle damage not covered by the vehicle warranty.

Note: Make sure you properly secure your vehicle to the tow vehicle.

Note: If you are unsure of the vehicle's configuration, contact an authorized dealer.

RECREATIONALLY TOWING YOUR VEHICLE - 4X4



WARNING: Do not disconnect the battery when recreationally towing your vehicle. This prevents the transfer case from shifting properly and could cause the vehicle to roll, even if the transmission is in park (P).



WARNING: Placing the transfer case in its neutral position could cause your vehicle to freely roll. Make sure you press and hold the brake pedal and the vehicle is in a secure, safe position when you place the transfer case in its neutral position.

Follow these guidelines if you have a need for recreational towing. An example of recreational towing would be towing your vehicle behind a motorhome. These guidelines are to make sure that you do not damage the transmission.

You can only tow your vehicle with all wheels on the ground by placing the transfer case in its neutral position and engaging the recreational tow feature. Perform the following steps after positioning your vehicle behind the tow vehicle and properly securing them together.

Note: Switch your climate control system to recirculated air mode to prevent exhaust fumes from entering your vehicle.

Note: Failure to put the transfer case in its neutral position can damage vehicle components.

Note: You can check the towing status at any time by opening the driver door or turning the ignition to the accessory or on position. Neutral Tow Enabled Leave Transmission in Neutral appears in the instrument cluster display to confirm you can recreationally tow your vehicle.

Note: If your vehicle has an anti-theft alarm, make sure you switch perimeter sensing on when towing. See **Arming the Anti-Theft Alarm System** (page 90).

Switching Neutral Tow On

1. Start your vehicle.
2. Press the 2H button on the four-wheel drive mode control.
3. Place your vehicle in temporary neutral mode. See **Temporary Neutral Mode** (page 194).
4. Switch your vehicle off by pressing the push button ignition switch once or turning the key as far toward the off position as possible. A message appears in the instrument cluster display.
5. Switch your vehicle to accessory mode by pressing the push button ignition switch once without pressing the brake pedal or by turning the key to the on position.

Towing Your Vehicle

6. Press and hold the brake pedal.
7. Access the Vehicle menu in the touchscreen.
8. Press and hold Neutral Tow until a confirmation message appears.

Note: If completed successfully, the instrument cluster display shows Neutral Tow Enabled Leave Transmission in Neutral. This indicates that your vehicle is safe to tow with all wheels on the ground.

Note: If you do not see a confirmation message in the instrument cluster display, you must perform the procedure again from the beginning.

Note: You may hear noise as the transfer case shifts into its neutral position. This is normal.

9. Release the brake pedal.
10. Leave the transmission in neutral (N) and switch your vehicle off by pressing the push button ignition switch once without pressing the brake pedal or turning the key as far toward the off position.

Note: Vehicles with keys do not turn to the off position when the transmission is in neutral (N). You must leave the key in the ignition when towing. Use the keyless entry keypad or an extra set of keys to lock and unlock your vehicle.

Note: For vehicles with electric brake booster, enabling neutral tow deactivates the brake booster. The red brake lamp illuminates in the instrument cluster indicating the brake booster is deactivated.

Switching Neutral Tow Off

1. With your vehicle properly secured to the tow vehicle, press and hold the brake pedal and start the engine.
2. Switch your vehicle off by pressing the push button ignition switch once or turning the key as far towards the off position and release the brake pedal.
3. Place your vehicle in accessory mode by pressing the push button ignition switch once without pressing the brake pedal or by turning the ignition key to the on position.
4. Press and hold the brake pedal.
5. Shift into park (P).
6. Release the brake pedal.

Note: If completed successfully, the instrument cluster displays 2H and Neutral Tow Disabled.

Note: You must perform the switching neutral tow on and switching neutral tow off procedures again from the beginning if the indicator light and message do not display.

Note: You may hear a noise as the transfer case shifts out of its neutral position. This is normal.

7. Apply the parking brake, then disconnect your vehicle from the tow vehicle.
8. Release the parking brake, start the engine, and shift into drive (D) to make sure the transfer case is out of the neutral tow position.
9. If the transfer case does not successfully shift out of its neutral position, set the parking brake. Have your vehicle checked as soon as possible.

Resolving the Shift Delayed Drive Forward Message

1. Press and hold the brake pedal.
2. Start your vehicle.
3. Shift into neutral (N).

Towing Your Vehicle

- With the vehicle running, shift into drive (D) and let the vehicle roll forward up to 3 ft (1 m).

Note: You may hear a noise as the transfer case shifts out of its neutral position. This is normal.

- Make sure the instrument cluster displays Neutral Tow Disabled.

RECREATIONALLY TOWING YOUR VEHICLE - 4X2

You cannot recreational tow your vehicle with all wheels on the ground because vehicle or transmission damage could occur. You must recreational tow your vehicle with all four wheels off the ground, such as when using a car-hauling trailer. Otherwise, you cannot recreational tow your vehicle.

EMERGENCY TOWING

If you need to tow your vehicle, contact a professional towing service or, if you are a member of a roadside assistance program, your roadside assistance service provider.

TOWING YOUR VEHICLE – TROUBLESHOOTING

TOWING YOUR VEHICLE – INFORMATION MESSAGES

Message	Description
Neutral Tow Enabled Leave Transmission in Neutral	The transfer case is in the neutral position and your vehicle is safe to tow with all four wheels on the ground.
Shift Delayed Drive Forward	There is a transfer case gear tooth blockage present. With your vehicle on, shift the transmission into drive (D) and let the vehicle roll forward, up to 3 ft (1 m).
Neutral Tow Disabled	The transfer case is not in the neutral position and your vehicle is not safe to tow with all four wheels on the ground.

Fuses

FUSE PRECAUTIONS

 **WARNING:** Always disconnect the battery before servicing high current fuses.

 **WARNING:** To reduce risk of electrical shock, always replace the cover to the power distribution box before reconnecting the battery or refilling fluid reservoirs.

 **WARNING:** Always replace a fuse with one that has the specified amperage rating. Using a fuse with a higher amperage rating can cause severe wire damage and could start a fire.

UNDER HOOD FUSE BOX

LOCATING THE UNDER HOOD FUSE BOX

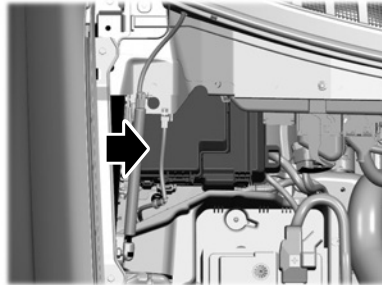

ACCESSING THE UNDER HOOD FUSE BOX

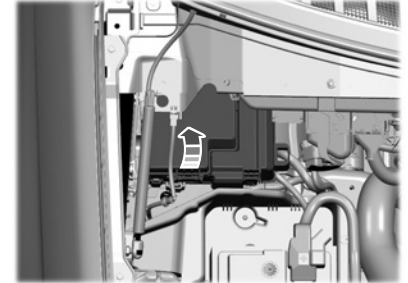

Fuses

IDENTIFYING THE FUSES IN THE UNDER HOOD FUSE BOX

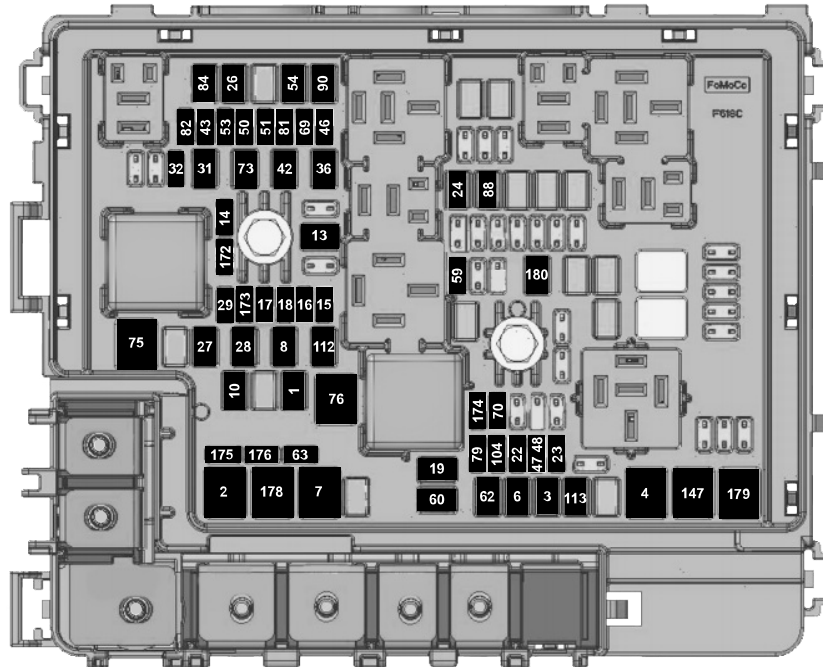

Fuses

Item	Rating	Protected Component
1	30 A	Body control module ignition 1 supply line.
2	30 A	Body control module ignition 2 supply line.
3	30 A	Body control module permanent power supply line.
4	60 A	Brake booster module.
6	30 A	Driver heated seat module.
7	60 A	Brake booster module.
8	30 A	Trailer brake control module.
10	25 A	Trailer tow module.
13	40 A	Four wheel drive control module.
14	5 A	Powertrain control module relay.
15	20 A	Powertrain control module ignition.
16	25 A	Vehicle power supply 2.
17	20 A	Vehicle power supply 3.
18	20 A	Vehicle power supply 4.
19	15 A	Transmission control module.
22	30 A	Right headlamp.

Fuses

Item	Rating	Protected Component
23	30 A	Left headlamp.
24	30 A	Starter motor.
26	30 A	Fuel pump control module.
27	20 A	Power outlet 1.
28	20 A	Power outlet 2.
29	10 A	Cargo USB charging port. Media bin USB charging port.
31	30 A	Front wiper motor.
32	5 A	Rain sensor module.
36	30 A	Body control module permanent power supply line.
42	20 A	Trailer brake control module. Trailer tow module.
43	30 A	Interior power distribution box.
47	15 A	Police spot lamps.
48	30 A	Digital sound processor. Amplifier.
49	5 A	Brake booster module.
50	10 A	Powertrain control module.

Fuses

Item	Rating	Protected Component
51	10 A	Air quality sensor module.
53	20 A	Rear seat control module.
54	40 A	Rear window heater module.
59	20 A	Horn.
60	30 A	Trailer parking lamp.
62	40 A	Blower motor.
63	10 A	Trailer backup lamp.
69	5 A	Power steering.
70	10 A	Smart data link connector.
73	20 A	Rear wiper motor.
75	50 A	Electric cooling fan 1.
76	50 A	Electric cooling fan 2.
79	5 A	Smart headlamp control module.
81	10 A	In-vehicle cooler.
82	5 A	Interior power distribution box run/start.
84	15 A	Fuel injectors.
88	40 A	Rear blower motor.

Fuses

Item	Rating	Protected Component
90	20 A	Windshield washer motor.
104	5 A	Brand logo lamp.
112	30 A	Second row seat motor - left.
113	30 A	Second row seat motor - right.
147	40 A	Intercooler fan.
172	5 A	Ambient lighting.
173	15 A	Driver seat USB charging port. Passenger seat USB charging port.
174	15 A	Rear entertainment system.
175	5 A	Left roof marker light.
176	5 A	Right roof marker light.
178	60 A	Driver door module.
179	60 A	Passenger door module.
180	30 A	Passenger heated seat module.

Fuses

INTERIOR FUSE BOX

LOCATING THE INTERIOR FUSE BOX

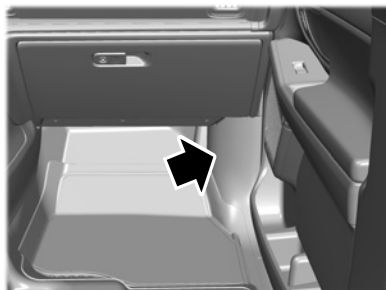

ACCESSING THE INTERIOR FUSE BOX

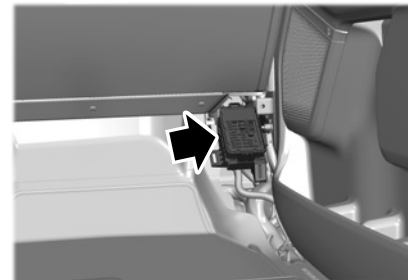

Fuses

IDENTIFYING THE FUSES IN THE INTERIOR FUSE BOX

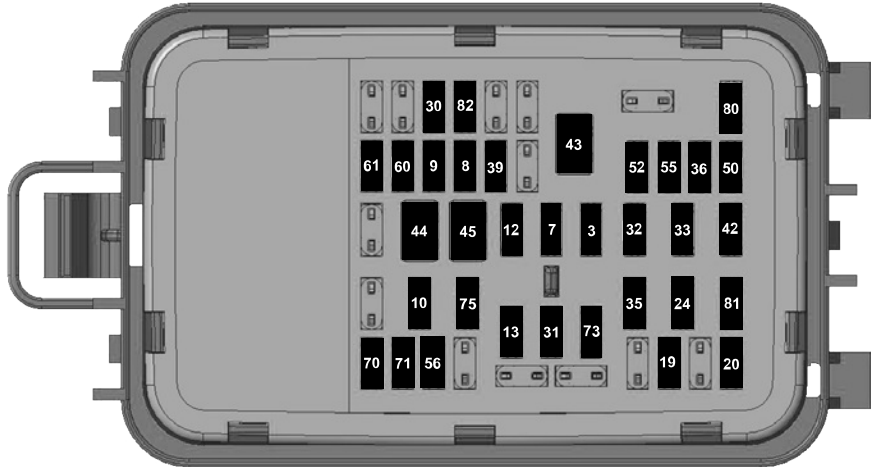

Fuses

Item	Rating	Protected Component
3	7.5 A	Wireless charger control module.
7	10 A	Gear shift module.
8	7.5 A	Telematics control module.
9	5 A	Rear climate control module. Keypad.
10	20 A	Front multi-contour seat module.
12	15 A	Climate control module.
13	7.5 A	Steering wheel control module.
19	5 A	Bluetooth low energy module.
20	5 A	Headlamp module.
24	30 A	Glass roof control module.
30	15 A	USB charging port 3. USB charging port 4.
31	10 A	Central gateway module. Terrain management gateway module. Roof mounted remote receiver.
32	20 A	Audio control module.
33	20 A	Instrument cluster control module.

Fuses

Item	Rating	Protected Component
35	10 A	Center console control module. Center stack display.
36	5 A	Interior air particulate sensor.
39	5 A	Driver state monitor control module.
42	20 A	Integrated control panel. Voice control module.
43	50 A	Power splitgate control module.
44	30 A	Front driver seat motor.
45	30 A	Front passenger seat motor.
50	7.5 A	Splitgate assembly.
52	5 A	Trailer brake switch.
55	15 A	Electrochromatic rear view mirror.
56	10 A	Driver power window switch.
60	10 A	Glass roof. Rear seat entertainment.
61	5 A	Center console slide switch.
70	20 A	Driver assistance system control module.
73	7.5 A	Wireless charger control module.

Fuses

Item	Rating	Protected Component
75	20 A	Not used (spare).
80	15 A	Steering wheel control module.
81	30 A	Center console slide motor.
82	10 A	Media connector.

IDENTIFYING FUSE TYPES

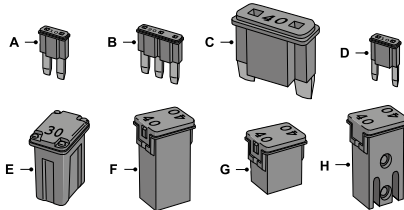

- A Micro 2.
- B Micro 3.
- C Maxi.
- D Mini.
- E M Case.

- F J Case.
- G J Case Low Profile.
- H Slotted M Case.

How do I identify a blown fuse?

- You can identify a blown fuse by a broken wire within the fuse.

FUSES – TROUBLESHOOTING

FUSES – FREQUENTLY ASKED QUESTIONS

When do I need to check a fuse?

- If electrical components in the vehicle are not working.

When do I need to replace a fuse?

- If a fuse has blown.

Maintenance

MAINTENANCE PRECAUTIONS

Service your vehicle regularly to help maintain its roadworthiness and resale value. There is a large network of authorized dealers that are there to help you with their professional servicing expertise. We believe that their specially trained technicians are best qualified to service your vehicle properly and expertly. They are supported by a wide range of highly specialized tools developed specifically for servicing your vehicle.

If your vehicle requires professional service, an authorized dealer can provide the necessary parts and service. Check your warranty information to find out which parts and services are covered.

Use only recommended fuels, lubricants, fluids and service parts conforming to specifications.

- Do not work on a hot engine.
- Make sure that nothing gets caught in moving parts.
- Do not work on a vehicle with the engine running in an enclosed space, unless you are sure you have enough ventilation.

- Keep all open flames and other burning material, such as cigarettes, away from the battery and all fuel related parts.
- Set the parking brake, shift the transmission to park (P) and block the wheels.

OPENING AND CLOSING THE HOOD

 **WARNING:** Make sure that you fully latch the hood before driving. Failure to follow this instruction could result in personal injury or death.



1. Pull the hood release handle under the left-hand side of the instrument panel.

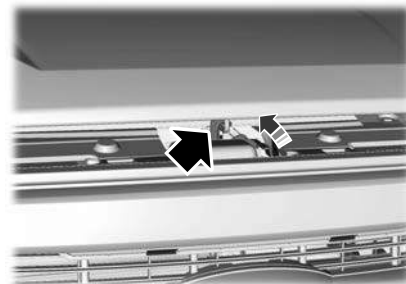

2. Pull the secondary release lever under the front of the hood near the center of your vehicle.
3. Raise the hood until the lift cylinders hold it open.
4. To close, lower the hood and make sure that it fully latches.

Maintenance

UNDER HOOD OVERVIEW

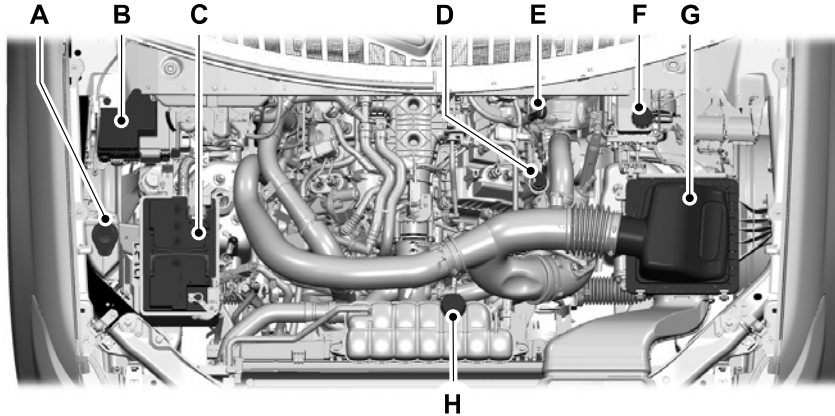

- A Windshield washer fluid reservoir. See **Adding Washer Fluid** (page 103).
- B Engine compartment fuse box. See **Accessing the Under Hood Fuse Box** (page 385).
- C Battery. See **Changing the 12V Battery** (page 408).
- D Engine oil filler cap. See **Adding Engine Oil** (page 398).
- E Engine oil dipstick. See **Engine Oil Dipstick Overview** (page 398).
- F Brake fluid reservoir. See **Checking the Brake Fluid** (page 212).

Maintenance

- G Air filter. See **Changing the Engine Air Filter** (page 401).
- H Engine coolant reservoir.

ENGINE OIL

ENGINE OIL DIPSTICK OVERVIEW

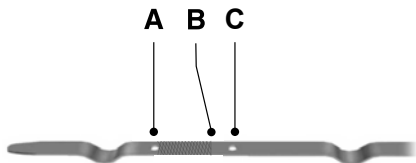

- A Minimum.
- B Nominal.
- C Maximum.

CHECKING THE ENGINE OIL LEVEL

1. Make sure that your vehicle is on level ground.
2. Check the oil level before starting the engine, or switch the engine off after warm up and wait 15 minutes for the oil to drain into the oil pan.

Note: Checking the oil level too soon could result in an inaccurate reading.

3. Remove the dipstick and wipe it with a clean, lint-free cloth.
4. Reinstall the dipstick and make sure it is fully seated.
5. Remove the dipstick again to check the oil level.

Note: Read both sides of the dipstick and use the lowest oil level as the correct reading.

Note: If the oil level is between the maximum and minimum marks, the oil level is acceptable. Do not add oil.

6. If the oil level is at the minimum mark, immediately add oil.

7. Reinstall the dipstick. Make sure it is fully seated.

Note: The oil consumption of new engines reaches its normal level after approximately 3,000 mi (5,000 km).

Note: Increases in oil level can occur from frequent short trips that do not allow the engine to get to operating temperature, as well as frequent idling or low speed driving for long periods of time.

Note: If oil levels are continuously noted above the maximum mark, have your vehicle checked as soon as possible.

ADDING ENGINE OIL

 **WARNING:** Do not remove the filler cap when the engine is running.

 **WARNING:** Do not add engine oil when the engine is hot. Failure to follow this instruction could result in personal injury.

Maintenance

Do not use supplemental engine oil additives because they are unnecessary and could lead to engine damage that the vehicle warranty may not cover.

1. Clean the area surrounding the engine oil filler cap before you remove it.
2. Remove the engine oil filler cap.
3. Add engine oil that meets our specifications. See **Engine Oil** (page 399).
4. Reinstall the engine oil filler cap. Turn it clockwise until you feel a strong resistance.

Note: *Do not add oil further than the maximum mark. Oil levels above the maximum mark may cause engine damage.*

Note: *Immediately soak up any oil spillage with an absorbent cloth.*

INTELLIGENT OIL LIFE MONITOR

Under certain conditions the vehicle's intelligent oil life monitor may determine your oil requires replacement prior to your general service. Should this occur it is recommended you replace your oil within two weeks or 500 mi (800 km) of being alerted.

Your authorized dealer will be able to advise you whether only an engine oil and filter change is recommended or whether you should complete your general service inclusive of oil and oil filter.

RESETTING THE INTELLIGENT OIL LIFE MONITOR

1. From the settings menu, press Vehicle.
2. Press and hold the Oil Life button until the system reset confirmation appears.

ENGINE OIL CAPACITY AND SPECIFICATION

Use oil that meets the defined specification and viscosity grade.

If you do not use oil that meets the defined specification and viscosity grade, it could result in:

- Component damage that your vehicle warranty does not cover.
- Longer engine cranking periods.
- Increased emission levels.

- Reduced vehicle performance.
- Reduced fuel economy.



An oil that displays this symbol conforms to current engine, emission system and fuel economy performance standards of ILSAC.

We recommend Motorcraft® motor oil for your vehicle. If Motorcraft® oil is not available, use motor oils of the recommended viscosity grade that display the API Certification Mark for gasoline engines.

Do not use supplemental engine oil additives because they are unnecessary and could lead to engine damage that your vehicle warranty does not cover.

Maintenance

Capacities

Variant	Including the Oil Filter
All.	6.0 qt (5.7 L)

Materials

Name	Specification
Motorcraft® SAE 5W-30 Motor Oil (U.S.) Motorcraft® SAE 5W-30 Motor Oil / Huile moteur SAE 5W-30 Motorcraft® (Canada) XO-5W30-Q1SP, XO-5W30-Q1FS (U.S.) CXO-5W30-LSP6, CXO-5W30-LFS6 (Canada)	WSS-M2C961-A1

Alternative Engine Oil for Extremely Cold Climates

To improve engine cold start performance, use the following engine oil in climates where the ambient temperature reaches -22.0°F (-30°C) or below.

Materials

Name	Specification
Engine Oil - SAE 0W-30	WSS-M2C963-A1

Maintenance

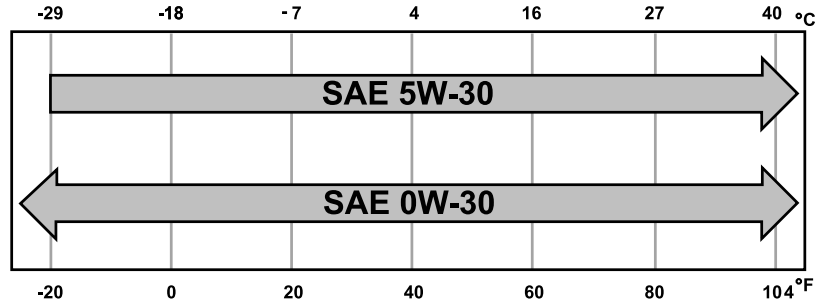

Note: If you use your vehicle regularly above the altitude of 5,000 ft (1,524 m) and under the temperature of -4.0°F (-20°C), it is recommended to use the alternative engine oil.

ENGINE AIR FILTER

CHANGING THE ENGINE AIR FILTER



WARNING: To reduce the risk of vehicle damage and personal burn injuries, do not start your engine with the air cleaner removed and do not remove it while the engine is running.

Change the engine air filter element at the proper intervals. See **Scheduled Maintenance** (page 490).

When changing the engine air filter, use only the air filter element listed. See **Motorcraft Parts** (page 416).

Note: Failure to use the correct air filter element may result in severe engine damage. Resulting component damage may not be covered by the vehicle Warranty.

Note: When servicing the air cleaner, do not allow foreign material to enter the air induction system.

Maintenance

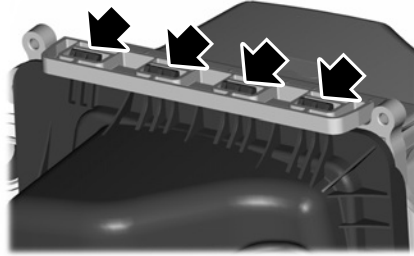
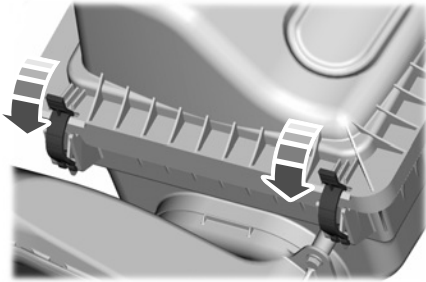

1. Release the two clamps that secure the cover to the air filter housing. Push the air filter cover toward the front of the vehicle and up slightly to release it.
2. Remove the air filter element from the air filter housing.
3. Install the new air filter element.
4. Replace the air filter housing cover and secure all the clamps. Be careful not to crimp the filter element edges between the air filter housing and cover, and make sure that you properly align the tabs on the edge into the slots.

COOLANT

CHECKING THE COOLANT LEVEL

 **WARNING:** Do not remove the coolant reservoir cap when the engine is on or the cooling system is hot. Wait 10 minutes for the cooling system to cool down. Cover the coolant reservoir cap with a thick cloth to prevent the possibility of scalding and slowly remove the cap. Failure to follow this instruction could result in personal injury.

 **WARNING:** To reduce the risk of personal injury, make sure the engine is cool before unscrewing the coolant pressure relief cap. The cooling system is under pressure. Steam and hot liquid can come out forcefully when you loosen the cap slightly.

When the engine is cold, check the concentration and level of the coolant at the intervals listed in the scheduled maintenance information.

Note: Make sure that the coolant level is between the **MIN** and the **MAX** marks on the coolant reservoir.

Maintenance

Note: Coolant expands when it is hot. The level may extend beyond the **MAX** mark. This is normal.

Maintain coolant concentration within 48% to 50%, which equates to a freeze point between -29°F (-34°C) and -35°F (-37°C). Coolant concentration should be checked using a refractometer. We do not recommend the use of hydrometers or coolant test strips for measuring coolant concentration.

ADDING COOLANT

 **WARNING:** Do not add coolant when the vehicle is on or the cooling system is hot. Failure to follow this instruction could result in personal injury.

 **WARNING:** Do not remove the coolant reservoir cap when the engine is on or the cooling system is hot. Wait 10 minutes for the cooling system to cool down. Cover the coolant reservoir cap with a thick cloth to prevent the possibility of scalding and slowly remove the cap. Failure to follow this instruction could result in personal injury.

 **WARNING:** Do not allow the fluid to touch your skin or eyes. If this happens, rinse the affected areas immediately with plenty of water and contact your physician.

 **WARNING:** Do not put coolant in the windshield washer reservoir. If sprayed on the windshield, coolant could make it difficult to see through the windshield.

 **WARNING:** Do not add coolant further than the **MAX** mark.

Note: Do not use stop leak pellets, cooling system sealants, or non-specified additives as they can cause damage to the engine cooling or heating systems. Resulting component damage may not be covered by the vehicle Warranty.

Note: Automotive fluids are not interchangeable.

It is very important to use prediluted coolant approved to the correct specification in order to avoid plugging the small passageways in the engine cooling system. See **Vehicle Specifications** (page 415). Do not mix different colors or types of coolant in your vehicle. Mixing of engine coolants or using an incorrect coolant may harm the engine or cooling system components and may not be covered by the vehicle Warranty.

Note: If prediluted coolant is not available, use the approved concentrated coolant diluting it to 50/50 with deionised or distilled water. See **Vehicle Specifications** (page 415). Using water that has not been deionised may contribute to deposit formation, corrosion and plugging of the small cooling system passageways.

Note: Coolants marketed for all makes and models may not be approved to our specifications and may cause damage to the cooling system. Resulting component damage may not be covered by the vehicle Warranty.

If the coolant level is at or below the minimum mark, add prediluted coolant immediately.

To top up the coolant level do the following:

1. Unscrew the cap slowly. Any pressure escapes as you unscrew the cap.

Maintenance

2. Add prediluted coolant approved to the correct specification. See **Vehicle Specifications** (page 415).
3. Add enough prediluted coolant to reach the correct level.
4. Replace the coolant reservoir cap. Turn the cap clockwise until it contacts the hard stop.
5. Check the coolant level in the coolant reservoir the next few times you drive your vehicle. If necessary, add enough prediluted engine coolant to bring the coolant level to the correct level.

If you have to add more than 1.1 qt (1 L) of engine coolant per month, have your vehicle checked as soon as possible. Operating an engine with a low level of coolant can result in engine overheating and possible engine damage.

In case of emergency, you can add a large amount of water without engine coolant in order to reach a vehicle service location.

Water alone, without engine coolant, can cause engine damage from corrosion, overheating or freezing.

Do not use the following as a coolant substitute:

- Alcohol.
- Methanol.
- Brine.
- Any coolant mixed with alcohol or methanol antifreeze.

Alcohol and other liquids can cause engine damage from overheating or freezing.

Do not add extra inhibitors or additives to the coolant. These can be harmful and compromise the corrosion protection of the coolant.

CHANGING THE COOLANT

For coolant change, see your authorized dealer.

Changing the coolant is necessary at specific mileage intervals listed in the scheduled maintenance information. See **Scheduled Maintenance** (page 490).

MANAGING THE COOLANT TEMPERATURE

If you tow a trailer with your vehicle, the engine may temporarily reach a higher temperature during severe operating conditions, for example ascending a long or steep grade in high ambient temperatures.

At this time, you may notice the coolant temperature gauge moves toward the red zone and a message may appear in the information display.



WARNING: To reduce the risk of crash and injury, be prepared that the vehicle speed may reduce and the vehicle may not be able to accelerate with full power until the coolant temperature reduces.



WARNING: If you continue to drive your vehicle when the engine is overheating, the engine could stop without warning. Failure to follow this instruction could result in the loss of control of your vehicle.

Maintenance

You may notice a reduction in vehicle speed caused by reduced engine power in order to manage the engine coolant temperature. Your vehicle may enter this mode if certain high-temperature and high-load conditions take place. The amount of speed reduction depends on vehicle loading, grade and outside temperature. If this occurs, there is no need to stop your vehicle. You can continue to drive. See **Fail-Safe Cooling** (page 380).

The air conditioning may automatically turn on and off during severe operating conditions to protect the engine from overheating. When the coolant temperature decreases to the normal operating temperature, the air conditioning turns on.

If the coolant temperature gauge moves fully into the red zone, or if the coolant temperature warning or service engine soon messages appear in your information display, do the following:

1. Stop your vehicle as soon as it is safe to do so. Fully apply the parking brake, shift into park (P) or neutral (N).
2. Leave the engine running until the coolant temperature gauge needle returns to the normal position. If the temperature does not drop after several minutes, follow the remaining steps.
3. Switch the engine off and wait for it to cool. Check the coolant level.

4. If the coolant level is at or below the minimum mark, add prediluted coolant immediately.
5. If the coolant level is normal, restart the engine and continue.

COOLING SYSTEM CAPACITY AND SPECIFICATION

Use coolant that meets the defined specification.

If you do not use coolant that meets the defined specification, it could result in:

- Component damage that your vehicle warranty does not cover.
- Reduced vehicle performance.

Capacities

Variant	Quantity
Standard duty trailer tow.	15.5 qt (14.7 L)
Heavy duty trailer tow.	15.85 qt (15 L)

Maintenance

Materials

Name	Specification
Motorcraft® Yellow Prediluted Antifreeze/Coolant(U.S.) Motorcraft® Yellow Prediluted Antifreeze/Coolant / Antigél/liquide de refroidissement prédilué jaune Motorcraft®(Canada) VC-13DL-G(U.S.) CVC-13DL-G(Canada)	WSS-M97B57-A2

COOLANT – WARNING LAMPS



A warning lamp illuminates and a message may appear in the information display.



If the engine begins to overheat, the coolant temperature gauge moves toward the red zone.

COOLANT – INFORMATION MESSAGES

Message	Description and Action
High engine temperature Stop safely	Displays when the engine temperature is too high. Stop your vehicle as soon as it is safe to do so, switch the engine off and allow it to cool. If the problem persists, have your vehicle checked as soon as possible. See Checking the Coolant Level (page 402).

Maintenance

CHANGING THE FUEL FILTER

Your vehicle has a lifetime fuel filter that integrates with the fuel tank. It does not need regular maintenance or replacement.

DRIVE BELT ROUTING OVERVIEW



Note: The long drive belt is on the inner groove closest to the engine. The short drive belt is on the outer groove farthest from the engine.

12V BATTERY

12V BATTERY PRECAUTIONS

⚠ WARNING: Batteries normally produce explosive gases which can cause personal injury. Therefore, do not allow flames, sparks or lighted substances to come near the battery. When working near the battery, always shield your face and protect your eyes. Always provide correct ventilation.

⚠ WARNING: When lifting a plastic-cased battery, excessive pressure on the end walls could cause acid to flow through the vent caps, resulting in personal injury and damage to the vehicle or battery. Lift the battery with a battery carrier or with your hands on opposite corners.

⚠ WARNING: Keep batteries out of reach of children. Batteries contain sulfuric acid. Avoid contact with skin, eyes or clothing. Shield your eyes when working near the battery to protect against possible splashing of acid solution. In case of acid contact with skin or eyes, flush immediately with water for a minimum of 15 minutes and get prompt medical attention. If acid is swallowed, call a physician immediately.

⚠ WARNING: Battery posts, terminals and related accessories contain lead and lead compounds, chemicals known to the State of California to cause cancer and reproductive harm. **Wash your hands after handling.**

⚠ WARNING: This vehicle may have more than one battery. Removing the battery cables from only one battery does not disconnect your vehicle electrical system. Make sure you disconnect the battery cables from all batteries when disconnecting power. Failure to do so may cause serious personal injury or property damage.

Maintenance



WARNING: For vehicles with Auto-Start-Stop the battery requirement is different. You must replace the battery with one of exactly the same specification.

WHAT IS THE BATTERY MANAGEMENT SYSTEM

The battery management system monitors battery conditions and takes actions to extend battery life.

HOW DOES THE BATTERY MANAGEMENT SYSTEM WORK

If excessive battery drain is detected, the system temporarily disables some electrical systems to protect the battery.

Systems included are:

- Heated rear window.
- Heated seats.
- Climate control.
- Heated steering wheel.
- Audio unit.
- Navigation system.

A message could appear in the information display to alert you that battery protection actions are active. This message is only for notification that an action is taking place, and not intended to indicate an electrical problem or that the battery requires replacement.

BATTERY MANAGEMENT SYSTEM LIMITATIONS

After battery replacement, or in some cases after charging the battery with an external charger, the battery management system requires eight hours of vehicle sleep time to relearn the battery state of charge. During this time, your vehicle must remain fully locked with the ignition switched off.

Note: *Prior to relearning the battery state of charge, the battery management system could temporarily disable some electrical systems.*

Electrical Accessory Installation

To make sure the battery management system works correctly, do not connect an electrical device ground connection directly to the battery negative post. This can cause inaccurate measurements of the battery condition and potential incorrect system operation.

Note: *If you add electrical accessories or components to the vehicle, it could adversely affect battery performance and durability. This could also affect the performance of other electrical systems in the vehicle.*

CHANGING THE 12V BATTERY

The battery is in the engine compartment. See **Maintenance** (page 396).

Your vehicle has a maintenance-free battery. It does not require additional water during service.

If the vehicle battery has a cover and vent hose, make sure you correctly install it after cleaning or replacing the battery.

For longer, trouble-free operation, keep the top of the battery clean and dry and the battery cables tightly fastened to the battery terminals. If any corrosion is present on the battery or terminals, remove the cables from the terminals and clean with a wire brush. You can neutralize the acid with a solution of baking soda and water.

We recommend that you disconnect the negative battery cable terminal from the battery if you plan to store your vehicle for an extended period.

Maintenance

Note: *If you only disconnect the negative battery cable terminal, make sure it is isolated or placed away from the battery terminal to avoid unintended connection or arcing.*

If you disconnect or replace the battery and your vehicle has an automatic transmission, it must relearn its adaptive strategy. Because of this, the transmission may shift firmly when first driven. This is normal operation while the transmission fully updates its operation to optimum shift feel.

Removing the Battery

1. Apply the parking brake and switch the ignition off.
2. Switch all electrical equipment off, for example lights and radio.
3. Wait a minimum of two minutes before disconnecting the battery.

Note: *The engine management system has a power hold function and remains powered for a period of time after you switch the ignition off. This is to allow diagnostic and adaptive tables to be stored. Disconnecting the battery without waiting can cause damage not covered by the vehicle Warranty.*

4. Disconnect and isolate the negative battery cable terminal.

5. Disconnect and isolate the positive battery cable terminal.
6. Remove the battery securing clamp.
7. Remove the battery.

If you disconnect or replace the vehicle battery, you must reset the following features:

- Window bounce-back. See **What Is Window Bounce-Back** (page 117).
- Clock Settings.
- Pre-set radio stations.

Replacing the Battery

Note: *Before reconnecting the battery, make sure the ignition remains switched off.*

You must replace the battery with one of exactly the same specification.

To install, reverse the removal procedure.

Note: *Make sure that you correctly install the battery terminal covers, battery cover and battery cable terminals.*

RESETTING THE BATTERY SENSOR

When you install a new battery, reset the battery sensor by doing the following:

1. Switch the ignition on, and leave the engine off.

Note: *Complete Steps 2 and 3 within 10 seconds.*

2. Flash the high beam headlamps five times, ending with the high beams off.
3. Press and release the brake pedal three times.

The battery warning lamp flashes three times to confirm that the reset is successful.

RECYCLING AND DISPOSING OF THE 12V BATTERY



Make sure that you dispose of old batteries in an environmentally friendly way. Seek advice from your local authority about recycling old batteries.

Maintenance

12V BATTERY – TROUBLESHOOTING



If it illuminates while driving, it indicates a charging system error. Switch off all unnecessary electrical equipment and have your vehicle immediately checked.

12V BATTERY – WARNING LAMPS

12V BATTERY – INFORMATION MESSAGES

Message	Details
Charging System Service Soon	The charging system needs servicing. If the warning stays on or continues to come on, have your vehicle checked as soon as possible. ¹
Charging System Service Now	The charging system needs servicing. Have your vehicle immediately checked. ¹
Turn Power Off To Save Battery	The battery management system determines that the battery is at a low state of charge. Turn the ignition off as soon as possible to protect the battery. The system clears this message once you start your vehicle and the battery state of charge recovers. Turning off unnecessary electrical loads allows for a faster battery state-of-charge recovery.

Maintenance

Message	Details
Electrical Power Saver Active Some Features Turned Off See Manual	Displays when the battery management system detects an extended low-voltage condition. The system disables various vehicle features to help preserve the battery. Turn off as many of the electrical loads as soon as possible to improve system voltage. If the system voltage recovers, the disabled features will operate again as normal. ¹
12V battery State of charge low	The battery management system determines that the 12V battery is at a low state of charge. Start the engine to charge the battery or charge the battery using an aftermarket battery charger. Always use the vehicle ground point when connecting the negative cable of the external battery charger. See Jump Starting the Vehicle (page 376). This message clears once you restart your vehicle and the battery state of charge has recovered. Do not switch on the ignition when a battery charger is in use to charge the battery. To resolve the issue after the battery reset, start and stop the vehicle three times. See Starting and Stopping the Engine (page 173). ²

¹Check Brake System message may also display.

²Check Brake System message may also display. Start and stop the vehicle three times or charge the battery to clear the message. If the message still appears, have the system checked as soon as possible.

ADJUSTING THE HEADLAMPS

Vertical Aim Adjustment

If your vehicle has been involved in a crash, have the aim of the headlamp beam checked by an authorized dealer.

Maintenance

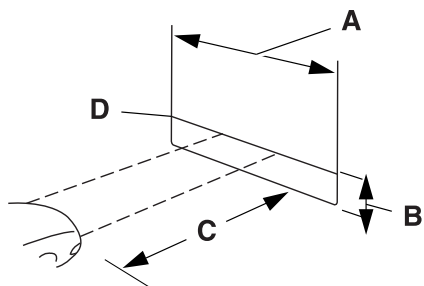

- A 8 ft (2.4 m).
- B Center height of lamp to ground (measurement B is relative to vehicle height).
- C 25 ft (7.6 m).
- D Horizontal reference line.

Vertical Aim Adjustment Procedure

1. Park your vehicle on level ground approximately 25 ft (7.6 m) from a wall or screen.
2. Measure the distance from the ground to the center of the headlamp and mark a 8 ft (2.4 m) long horizontal reference line on the wall or screen at this height.

Note: There may be an identifying mark on the lens to help you locate the center line of the headlamp.

Note: To see a clearer light pattern for adjusting, you may want to block the light from one headlamp while adjusting the other.

3. Switch on the low beam headlamps and open the hood.



4. On the wall or screen you will observe a flat zone of high intensity light located at the top of the beam pattern. If the top edge of the flat zone of high intensity light is not on the horizontal reference line, adjust the aim of the headlamp beam.

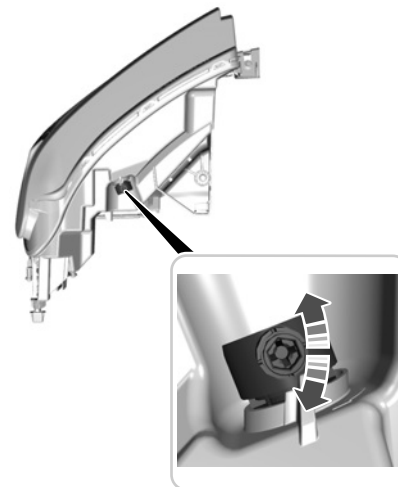

5. Use a suitable tool, for example a screwdriver or socket wrench, to turn the adjuster clockwise or counterclockwise to adjust the vertical aim of the headlamp. The horizontal edge of the brighter light should touch the horizontal reference line.
6. Close the hood and switch off the lamps.

Maintenance

EXTERIOR BULBS

Replacement bulbs are specified in the chart below.

EXTERIOR BULB SPECIFICATION CHART

Lamp	Specification	Power (Watt)
Front turn signal.	LED	LED
Daytime running lamp.	LED	LED
Headlamp low beam.	LED	LED
Headlamp high beam.	LED	LED
Front fog lamp.	LED	LED
Front side marker lamp.	LED	LED
Side turn signal.	LED	LED
Rear lamp, stoplamp and rear turn signal.	LED	LED
Central high mounted brake lamp.	LED	LED
Reversing lamp (high series).	LED	LED
License plate lamp.	W5W	5

LED lamps are not serviceable. Contact an authorized dealer if they fail.

Maintenance

Warning Lamps and Indicators

Exterior Bulb Failure



It illuminates when the ignition is on and there is an exterior bulb failure.

CHANGING A LICENSE PLATE LAMP BULB

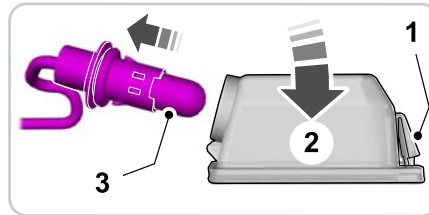
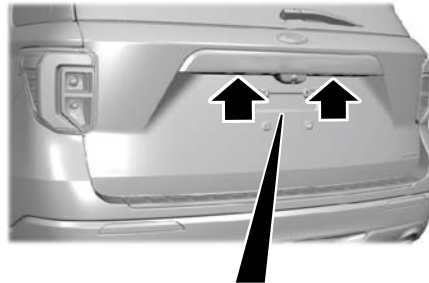

1. Use a suitable tool, for example a screwdriver, to carefully remove the lamp.
2. Turn the bulb holder counterclockwise and remove it.

3. Remove the bulb by pulling it straight out.
4. To install, reverse the removal procedure.

INTERIOR BULBS

INTERIOR BULB SPECIFICATION CHART

Your vehicle has LED lamps. These are not serviceable items. See an authorized dealer if they fail.

Vehicle Specifications

ENGINE SPECIFICATIONS

Engine	Specification
Compression ratio.	10.5:1
Displacement.	213.4 in ³ (3,497 cm ³)
Firing order.	1-4-2-5-3-6
Ignition system.	Coil on plug
Spark plug gap.	0.028 in (0.7 mm) - 0.031 in (0.8 mm)

Vehicle Specifications

MOTORCRAFT PARTS

Component	Motorcraft Part Number
Air filter element.	FA-1883
Battery. ¹	See note below. ²
Cabin air filter.	FP-125
Engine oil filter. ³	FL-500-S
Rear window wiper blade.	WW-1114
Spark plug.	SP-596
Windshield wiper blade.	WW-2998

¹ Configure your vehicle's battery management system to match the replacement battery. Failure to use an appropriate configuration for your battery management system could result in shortened battery life, features not working correctly, or your vehicle not starting. Consult your local dealer or service provider for further details.

² See your dealer for the most current part number.

³ If a Motorcraft oil filter is not available, use an oil filter that aligns to SAE/USCAR – 36 Performance Specifications. Filter Type C.

We recommend Motorcraft parts that are available at your authorized dealer or at www.parts.ford.com. We engineer these parts for your vehicle to meet or exceed our specifications. Use of other parts could impact vehicle performance, emissions and durability. Your warranty could be void for any damage related to use of other parts.

Vehicle Care

CLEANING PRODUCTS

For best results, use the following products or products of equivalent quality:

For additional information and assistance, we recommend that you contact an authorized dealer.

Materials

Name	Specification
Motorcraft® Bug and Tar Remover, ZC-42 (U.S. & Canada)	
Motorcraft® Custom Bright Metal Cleaner, ZC-15 (U.S. & Canada)	ESR-M5B194-B
Motorcraft® Detail Wash, ZC-3-A (U.S. & Canada)	ESR-M14P4-A
Motorcraft® Engine Shampoo and Degreaser, ZC-20 (U.S.)	ESR-M14P3-A
Motorcraft® Engine Shampoo, CXC-66-A (Canada)	
Motorcraft® Premium Leather and Vinyl Cleaner, ZC-56 (U.S. & Canada)	
Motorcraft® Multi-Purpose Cleaner, CXC-101 (Canada)	
Motorcraft® Premium Windshield Wash Concentrate with Bitterant, ZC-32-B2 (U.S.)	WSS-M14P19-A
Motorcraft® Premium Quality Windshield Washer Fluid, CXC-37-F/M (Canada)	WSS-M14P19-A
Motorcraft® Professional Strength Carpet & Upholstery Cleaner, ZC-54 (U.S. & Canada)	
Motorcraft® Premium Glass Cleaner, CXC-100 (Canada)	ESR-M14P5-A
Motorcraft® Spot and Stain Remover, ZC-14 (U.S.)	
Motorcraft® Ultra-Clear Spray Glass Cleaner, ZC-23 (U.S.)	ESR-M14P5-A
Motorcraft® Wheel and Tire Cleaner, ZC-37-A (U.S. & Canada)	

Vehicle Care

CLEANING THE EXTERIOR

CLEANING THE EXTERIOR PRECAUTIONS

Immediately remove fuel spillages, additive residuals, bird droppings, insect deposits and road tar. These may damage your vehicle's paintwork or trim over time. Remove any exterior accessories, for example antennas, before entering a car wash.

Note: *If you intend to park your vehicle for an extended period after cleaning, drive it for few minutes before parking. This reduces the risk of corrosion of the brake discs, brake pads and linings.*

CLEANING HEADLAMPS AND REAR LAMPS

We recommend that you only use cold or lukewarm water containing car shampoo to clean the headlamps and the rear lamps.

Do not scrape the lamps.

Do not wipe lamps when they are dry.

CLEANING WINDOWS AND WIPER BLADES

To clean the windshield and wiper blades:

- Clean the windshield with a non-abrasive glass cleaner.

Note: *When cleaning the interior of the windshield, avoid getting any glass cleaner on the instrument panel or door panels. Wipe any glass cleaner off these surfaces immediately.*

- Clean the wiper blades with washer fluid or water applied with a soft sponge or cloth.

Note: *Do not use razor blades or other sharp objects to clean or remove decals from the inside of the heated rear window. This can cause damage not covered by the vehicle Warranty.*

CLEANING WHEELS

Only use a recommended wheel and tire cleaner to clean the wheels. For additional information and assistance, we recommend that you contact an authorized dealer.

1. Use a sponge to remove heavy deposits of dirt and brake dust.
2. Rinse well after cleaning.

Note: *Do not apply a cleaning chemical to warm or hot wheel rims and covers.*

If you intend to park your vehicle for an extended period after cleaning the wheels, drive it for few minutes before parking. This reduces the risk of corrosion of the brake discs, brake pads and linings.

Do not clean the wheels when they are hot.

Note: *Some car washes could damage wheel rims and covers.*

Note: *Using non-recommended cleaners, harsh cleaning products, chrome wheel cleaners or abrasive materials could damage wheel rims and covers.*

CLEANING THE ENGINE COMPARTMENT

Use a vacuum cleaner to remove debris from the screen area below the windshield.

Note: *If you are not familiar with the parts around the engine do not wash the engine compartment. Avoid frequent engine washes.*

Vehicle Care

When washing the engine compartment:

- Never wash or rinse the engine while it is hot or running.
- Never wash or rinse any ignition coil, spark plug wire or spark plug well.
- Cover the battery, power distribution box, and air filter assembly to prevent water damage.

Note: *If your vehicle has an engine cover remove the cover before application of shampoo and degreaser.*

- Spray an approved engine shampoo and degreaser on all parts that require cleaning and rinse with water.

Note: *Follow the manufacturer's instructions for using engine shampoo and degreaser.*

CLEANING STRIPES OR GRAPHICS

It is recommended to wash your vehicle by hand however, pressure washing may be used under the following conditions:

- Use a spray with a minimum of 40° wide spray angle pattern.
- Keep the nozzle 12 in (30 cm) and at a 90° angle to your vehicle.

- Do not use water pressure higher than 1,000 psi (6,895 kPa).
- Do not use water hotter than 73°F (23°C).

Note: *Holding the pressure washer nozzle at an angle to the vehicle's surface may damage graphics and cause the edges to peel away.*

CLEANING CAMERA LENSES AND SENSORS

We recommend that you only use lukewarm or cold water and a soft cloth to clean the camera lens and sensors.

Note: *Do not pressure wash camera lens and sensors.*

CLEANING THE UNDERBODY

Flush the complete underside of your vehicle frequently. Keep body and door drain holes free from packed dirt.

Rear suspension components may require regular cleaning with a power washer or a thorough rinse with a strong stream of water if the vehicle is operated in dusty or muddy environments. Rear leaf springs or other suspension components may emit squeaking or popping noises while operating the vehicle if particles, such as dirt, rocks, or other debris, are present in the components.

CLEANING THE INTERIOR

CLEANING THE INSTRUMENT PANEL



WARNING: Do not use chemical solvents or strong detergents when cleaning the steering wheel or instrument panel to avoid contamination of the airbag system.

We recommend that you only clean the instrument panel and cluster lens with a damp soft cloth. Dry the area with a clean, soft cloth.

For additional information and assistance, we recommend that you contact an authorized dealer.

Vehicle Care

Note: Avoid cleaners or polishes that increase the gloss of the upper portion of the instrument panel. The dull finish in this area helps protect you from undesirable windshield reflection.

CLEANING PLASTIC

We recommend that you only use a mild soap and water solution on a soft cloth. Dry the area with a clean, soft cloth.

CLEANING DISPLAYS AND SCREENS

We recommend that you only use a microfiber cloth in a circular motion to clean off the fingerprint or dust.

Note: Do not pour or spray alcohol onto the touchscreen.

Note: Do not use detergent or any type of solvent to clean the touchscreen.

CLEANING FABRIC



WARNING: On vehicles equipped with seat-mounted airbags, do not use chemical solvents or strong detergents. Such products could contaminate the side airbag system and affect performance of the side airbag in a crash.

We recommend that you only clean fabric in the following way:

1. Remove dust and loose dirt with a vacuum cleaner.
2. Wipe the surface with a soft, damp cloth and a mild soap and water solution. Dry the area with a clean, soft cloth.
3. For additional information and assistance, we recommend that you contact an authorized dealer.

For heavy stains, spot clean the area. If a ring forms on the fabric, clean the entire area immediately, but do not oversaturate or the ring could set.

CLEANING LEATHER



WARNING: On vehicles equipped with seat-mounted airbags, do not use chemical solvents or strong detergents. Such products could contaminate the side airbag system and affect performance of the side airbag in a crash.

We recommend that you only clean the leather surfaces in the following way:

1. Remove dust and loose dirt with a vacuum cleaner.
2. Wipe the surface with a soft, damp cloth and a mild soap and water solution. Dry the area with a clean, soft cloth.
3. Make sure the leather is dry, then apply a small amount of conditioner to a clean, dry cloth.
4. Rub the conditioner into the leather until it disappears. Allow the conditioner to dry, then repeat the process for the entire interior. If a film appears, wipe it off with a dry, clean cloth.
5. For additional information and assistance, we recommend that you contact an authorized dealer.

Vehicle Care

CLEANING VINYL



WARNING: On vehicles equipped with seat-mounted airbags, do not use chemical solvents or strong detergents. Such products could contaminate the side airbag system and affect performance of the side airbag in a crash.

We recommend that you only clean vinyl surfaces in the following way:

1. Remove dust and loose dirt with a vacuum cleaner.
2. Wipe the surface with a soft, damp cloth and a mild soap and water solution. Dry the area with a clean, soft cloth.
3. For additional information and assistance, we recommend that you contact an authorized dealer.

CLEANING CARPETS AND FLOOR MATS

We recommend that you only clean your carpets in the following way:

1. Remove dust and loose dirt with a vacuum cleaner.

2. Wipe the surface with a soft, damp cloth and a mild soap and water solution. Dry the area with a clean, soft cloth.
3. For additional information and assistance, we recommend that you contact an authorized dealer.

For heavy stains, spot clean the area. If a ring forms on the fabric, clean the entire area immediately, but do not oversaturate or the ring could set.

We recommend that you only clean your floor mats in the following way:

1. Remove dust and loose dirt with a vacuum cleaner.
2. Wash rubber floor mats using mild soap and lukewarm or cold water.
3. Completely dry the floor mat before placing them back in your vehicle.

CLEANING SEATBELTS



WARNING: Do not use cleaning solvents, bleach or dye on the vehicle's seatbelts, as these actions may weaken the belt webbing.

1. Wipe the surface with a soft, damp cloth and a mild soap and water solution. Dry the area with a clean, soft cloth.

CLEANING GLASS ROOF TRACKS

1. Remove debris from the tracks with a vacuum cleaner.
2. Wipe the bulb seal and mating painted roof metal surface with a soft, damp cloth and a mild soap and water solution.

Note: *The glass roof rail tracks are greased to maintain proper functionality. Do not wipe off the grease.*

REPAIRING MINOR PAINT DAMAGE

We recommend that you contact an authorized dealer to identify your vehicle color code. Authorized dealers have touch-up paint to match your vehicle's color.

Before repairing minor paint damage, use a cleaner to remove particles such as bird droppings, tree sap, insect deposits, tar spots, road salt and industrial fallout.

Read the instructions before using cleaning products.

Vehicle Care

WAXING YOUR VEHICLE

Wax the high-gloss painted surface of your prewashed vehicle once or twice a year.

We recommend that you only use an approved quality wax that does not contain abrasives. Follow the manufacturer's instructions to apply and remove the wax. For additional information and assistance, we recommend that you contact an authorized dealer.

When washing and waxing, park your vehicle in a shaded area out of direct sunlight.

Note: *Avoid waxing unpainted or low-gloss black colored parts, they discolor over time.*

Storing Your Vehicle

PREPARING YOUR VEHICLE FOR STORAGE

If you plan on storing your vehicle for 30 days or more, the following maintenance recommendations makes sure your vehicle stays in good operating condition.

Under various conditions, long-term storage may lead to degraded engine performance or failure unless you use specific precautions to preserve your vehicle.

General

- Store all vehicles in a dry, ventilated place.
- If vehicles are stored outside, they require regular maintenance to protect against rust and weather damage.
- Make sure all linkages, cables, levers and pins under your vehicle are covered with grease to prevent rust.
- Move vehicles at least 25 ft (7.5 m) every 15 days to lubricate working parts and prevent corrosion.
- Fill the fuel tank with high-quality fuel until the first automatic shutoff of the fuel pump nozzle.

Engine

- Change the engine oil and filter prior to storage because used engine oil contains contaminants which may cause engine damage.
- Start the engine every 15 days for a minimum of 15 minutes. Run at fast idle with the climate controls set to defrost until the engine reaches normal operating temperature.
- With your foot on the brake, shift through all the gears while the engine is running.

Body

- Wash your vehicle thoroughly to remove dirt, grease, oil, tar or mud from exterior surfaces, rear wheel housings and the underside of front fenders.
- Periodically wash your vehicle if it is stored in exposed locations.
- Touch-up exposed or primed metal to prevent rust.
- Cover chrome and stainless steel parts with a thick coat of auto wax to prevent discoloration. Rewax as necessary when you wash your vehicle.

- Lubricate all hood, door and luggage compartment hinges and latches with a light grade oil.
- Cover interior trim to prevent fading.
- Keep all rubber parts free from oil and solvents.

12 Volt Battery

- When storing your vehicle for longer than 30 days the battery state of charge should be approximately 50%. Additionally, we recommend to disconnect the 12v battery to reduce system loads on the battery, or you can use a trickle charger for longer storage periods.
- Check and recharge as necessary. Keep connections clean.

Note: *It is necessary to reset memory features if you disconnect the battery cables.*

Storing Your Vehicle

Tires

- Maintain recommended air pressure.
- To minimize flat spots on the tires, inflate all four tires to the recommended cold pressures listed on the Safety Compliance Certification label or Tire Label affixed to your vehicle. When the vehicle is taken out of storage, reset the tire pressures as necessary to the recommended levels listed on the Safety Compliance Certification label or Tire Label affixed to your vehicle.

Note: *If you store your vehicle in a location with low ambient temperatures, follow the instructions for care of summer tires.*

Brakes

Make sure the brakes and parking brake fully release.

Note: *If you intend to park your vehicle for an extended period after cleaning, drive it for few minutes before parking. This reduces the risk of corrosion of the brake discs, brake pads and linings.*

REMOVING YOUR VEHICLE FROM STORAGE

When your vehicle is ready to come out of storage, do the following:

- We recommend that you change the engine oil before you use your vehicle again.
- Wash your vehicle to remove any dirt or grease film build-up on window surfaces.
- Check windshield wipers for any deterioration.
- Check the underhood for any foreign materials such as mice or squirrel nests.
- Check the exhaust for any foreign materials.
- Check tire pressures and set tire inflation per the Tire Label.
- Check brake pedal operation. Corroded brake rotors could cause brake noise. Drive your vehicle and gently apply and release the brakes repeatedly over a 10-minute drive to reduce the corrosion from the brakes.

- Check fluid levels (including coolant, oil and gas) to make sure there are no leaks, and fluids are at recommended levels.
- If you remove the battery, clean the battery cable ends and check for damage.

Contact an authorized dealer if you have any concerns or issues.

Wheel and Tire Information

LOCATING THE TIRE LABEL

You will find a Tire Label containing tire inflation pressure by tire size and other important information located on the B-Pillar or the edge of the driver's door. See **Locating the Safety Compliance Certification Labels** (page 321).

DEPARTMENT OF TRANSPORTATION UNIFORM TIRE QUALITY GRADES



Tire Quality Grades apply to new pneumatic passenger car tires. The Quality grades can be found where applicable on the tire sidewall between tread shoulder and maximum section width. For example: **Treadwear 200 Traction AA Temperature A**.

These Tire Quality Grades are determined by standards that the United States Department of Transportation has set.

Tire Quality Grades apply to new pneumatic passenger car tires. They do not apply to deep tread, winter-type snow tires, space-saver or temporary use spare tires, light truck or LT type tires, tires with nominal rim diameters of 10 to 12 inches or limited production tires as defined in Title 49 Code of Federal Regulations Part 575.104 (c) (2).

U.S. Department of Transportation Tire quality grades: The U.S. Department of Transportation requires us to give you the following information about tire grades exactly as the government has written it.

Treadwear

The treadwear grade is a comparative rating based on the wear rate of the tire when tested under controlled conditions on a specified government test course. For example, a tire graded 150 would wear 1½ times as well on the government course as a tire graded 100. The relative performance of tires depends upon the actual conditions of their use, however, and may depart significantly from the norm due to variations in driving habits, service practices, and differences in road characteristics and climate.

Wheel and Tire Information

Traction AA A B C



WARNING: The traction grade assigned to this tire is based on straight-ahead braking traction tests, and does not include acceleration, cornering, hydroplaning or peak traction characteristics.

The traction grades, from highest to lowest are AA, A, B, and C. The grades represent the tire's ability to stop on wet pavement as measured under controlled conditions on specified government test surfaces of asphalt and concrete. A tire marked C may have poor traction performance.

Temperature A B C



WARNING: The temperature grade for this tire is established for a tire that is properly inflated and not overloaded. Excessive speed, underinflation, or excessive loading, either separately or in combination, can cause heat buildup and possible tire failure.

The temperature grades are A (the highest), B and C, representing the tire's resistance to the generation of heat and its ability to dissipate heat when tested under controlled conditions on a specified indoor laboratory test wheel. Sustained high temperature can cause the material of the tire to degenerate and reduce tire life, and excessive temperature can lead to sudden tire failure. The grade C corresponds to a level of performance which all passenger car tires must meet under

the Federal Motor Vehicle Safety Standard No. 139. Grades B and A represent higher levels of performance on the laboratory test wheel than the minimum required by law.

INFORMATION ON THE TIRE SIDEWALL

Both United States and Canada Federal regulations require tire manufacturers to place standardized information on the sidewall of all tires. This information identifies and describes the fundamental characteristics of the tire and also provides a U.S. DOT Tire Identification Number for safety standard certification and in case of a recall.

Wheel and Tire Information

Information on P Type Tires

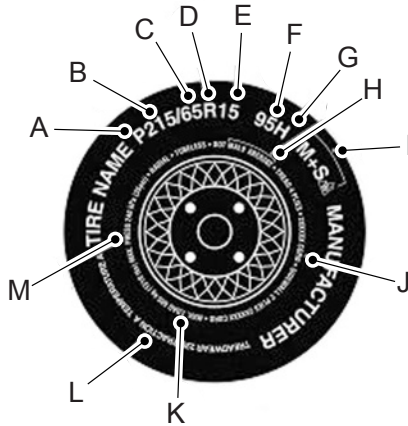

P215/65R15 95H is an example of a tire size, load index and speed rating. The definitions of these items are listed below. (Note that the tire size, load index and speed rating for your vehicle may be different from this example.)

A. **P:** Indicates a tire, designated by the Tire and Rim Association, that may be used for service on cars, sport utility vehicles, minivans and light trucks. **Note:** If your tire size does not begin with a letter this may mean it is designated by either the European Tire and Rim Technical Organization or the Japan Tire Manufacturing Association.

B. **215:** Indicates the nominal width of the tire in millimeters from sidewall edge to sidewall edge. In general, the larger the number, the wider the tire.

C. **65:** Indicates the aspect ratio which gives the tire's ratio of height to width.

D. **R:** Indicates a radial type tire.

E. **15:** Indicates the wheel or rim diameter in inches. If you change your wheel size, you will have to purchase new tires to match the new wheel diameter.

F. **95:** Indicates the tire's load index. It is an index that relates to how much weight a tire can carry. You may find this information in your owner's manual. If not, contact a local tire dealer.

Note: You may not find this information on all tires because it is not required by federal law.

G. **H:** Indicates the tire's speed rating. The speed rating denotes the speed at which a tire is designed to be driven for extended periods of time under a standard condition of load and inflation pressure. The tires on your vehicle may operate at different conditions for load and inflation pressure. These speed ratings may need to be adjusted for the difference in conditions. The ratings range from 81 mph (130 km/h) to 186 mph (300 km/h). These ratings are listed in the following chart.

Wheel and Tire Information

Note: You may not find this information on all tires because it is not required by federal law.

Letter rating	Speed rating
M	81 mph (130 km/h)
N	87 mph (140 km/h)
Q	99 mph (160 km/h)
R	106 mph (170 km/h)
S	112 mph (180 km/h)
T	118 mph (190 km/h)
U	124 mph (200 km/h)
H	130 mph (210 km/h)
V	149 mph (240 km/h)

Letter rating	Speed rating
W	168 mph (270 km/h)
Y	186 mph (300 km/h)

Note: For tires with a maximum speed capability over 149 mph (240 km/h), tire manufacturers sometimes use the letters ZR. For those with a maximum speed capability over 186 mph (299 km/h), tire manufacturers always use the letters ZR.

H. U.S. DOT Tire Identification

Number (TIN): This begins with the letters DOT and indicates that the tire meets all federal standards. The next two numbers or letters are the plant code designating where it was manufactured, the next two are the tire size code and the last four numbers represent the week and year the tire was built. For example, the numbers 317 mean the 31st week of 1997. After 2000, the numbers go to four digits. For example, 2501

means the 25th week of 2001. The numbers in between are identification codes used for traceability. This information is used to contact customers if a tire defect requires a recall.

I. **M+S or M/S:** Mud and Snow, or

AT: All Terrain, or

AS: All Season.

J. Tire Ply Composition and

Material Used: Indicates the number of plies or the number of layers of rubber-coated fabric in the tire tread and sidewall. Tire manufacturers also must indicate the ply materials in the tire and the sidewall, which include steel, nylon, polyester, and others.

Wheel and Tire Information

K. Maximum Load: Indicates the maximum load in kilograms and pounds that can be carried by the tire. See the Safety Compliance Certification Label (affixed to either the door hinge pillar, door-latch post, or the door edge that meets the door-latch post, next to the driver's seating position), for the correct tire pressure for your vehicle.

L. Treadwear, Traction and Temperature Grades:

***Treadwear:** The treadwear grade is a comparative rating based on the wear rate of the tire when tested under controlled conditions on a specified government test course. For example, a tire graded 150 would wear one and one-half times as well on the government course as a tire graded 100.

***Traction:** The traction grades, from highest to lowest are AA, A, B, and C. The grades represent the tire's ability to stop on wet pavement as measured under controlled conditions on specified government test surfaces of asphalt and concrete. A tire marked C may have poor traction performance.

***Temperature:** The temperature grades are A (the highest), B and C, representing the tire's resistance to the generation of heat and its ability to dissipate heat when tested under controlled conditions on a specified indoor laboratory test wheel.

M. Maximum Inflation Pressure: Indicates the tire manufacturers' maximum permissible pressure or the pressure at which the maximum load can be carried by the tire. This pressure is normally higher than the vehicle manufacturer's recommended cold inflation pressure which can be found on the Safety Compliance Certification Label (affixed to either the door

hinge pillar, door-latch post, or the door edge that meets the door-latch post, next to the driver's seating position), or Tire Label which is located on the B-Pillar or the edge of the driver's door. The cold inflation pressure should never be set lower than the recommended pressure on the vehicle label.

The tire suppliers may have additional markings, notes or warnings such as standard load or radial tubeless.

Additional Information Contained on the Tire Sidewall for LT Type Tires

Note: *Tire Quality Grades do not apply to this type of tire.*

Wheel and Tire Information

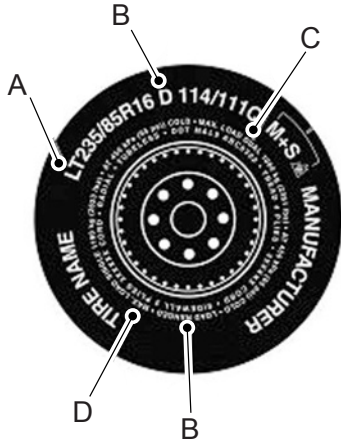

B. Load Range and Load Inflation Limits: Indicates the tire's load-carrying capabilities and its inflation limits.

C. Maximum Load Dual lb (kg) at psi (kPa) cold: Indicates the maximum load and tire pressure when the tire is used as a dual, defined as four tires on the rear axle (a total of six or more tires on the vehicle).

D. Maximum Load Single lb (kg) at psi (kPa) cold: Indicates the maximum load and tire pressure when the tire is used as a single, defined as two tires (total) on the rear axle.

Information on T Type Tires

T145/80D16 is an example of a tire size.

Note: *The temporary tire size for your vehicle may be different from this example. Tire Quality Grades do not apply to this type of tire.*

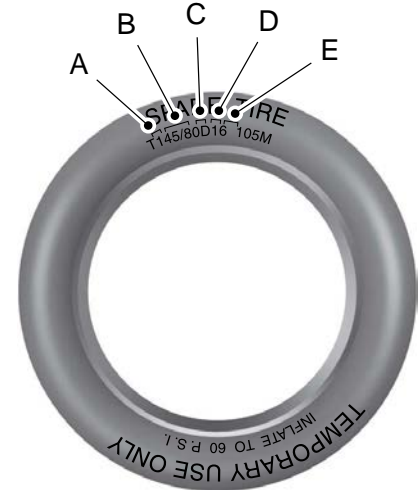

LT type tires have some additional information beyond those of P type tires; these differences are described below.

A. **LT:** Indicates a tire, designated by the Tire and Rim Association, that is intended for service on light trucks.

T type tires have some additional information beyond those of P type tires; these differences are described below:

Wheel and Tire Information

A. **T:** Indicates a type of tire, designated by the Tire and Rim Association, that is intended for temporary service on cars, sport utility vehicles, minivans and light trucks.

B. **145:** Indicates the nominal width of the tire in millimeters from sidewall edge to sidewall edge. In general, the larger the number, the wider the tire.

C. **80:** Indicates the aspect ratio which gives the tire's ratio of height to width. Numbers of 70 or lower indicate a short sidewall.

D. **D:** Indicates a diagonal type tire.

R: Indicates a radial type tire.

E. **16:** Indicates the wheel or rim diameter in inches. If you change your wheel size, you will have to purchase new tires to match the new wheel diameter.

GLOSSARY OF TIRE TERMINOLOGY

***Tire label:** A label showing the original equipment tire sizes, recommended inflation pressure and the maximum weight the vehicle can carry.

***Tire Identification Number (TIN):** A number on the sidewall of each tire providing information about the tire brand and manufacturing plant, tire size and date of manufacture. Also referred to as DOT code.

***Inflation pressure:** A measure of the amount of air in a tire.

***Standard load:** A class of P-metric or Metric tires designed to carry a maximum load at set pressure. For example: For P-metric tires 35 psi (2.4 bar) and for Metric tires 36 psi (2.5 bar). Increasing the inflation pressure beyond this pressure will not increase the tire's load carrying capability.

***Extra load:** A class of P-metric or Metric tires designed to carry a heavier maximum load at 42 psi (2.9 bar). Increasing the inflation pressure beyond this pressure will not increase the tire's load carrying capability.

***kPa:** Kilopascal, a metric unit of air pressure.

***PSI:** Pounds per square inch, a standard unit of air pressure.

***Cold tire pressure:** The tire pressure when the vehicle has been stationary and out of direct sunlight for an hour or more and prior to the vehicle being driven for 1 mi (1.6 km).

Wheel and Tire Information

***Recommended inflation pressure:**

The cold inflation pressure found on the Safety Compliance Certification Label (affixed to either the door hinge pillar, door-latch post, or the door edge that meets the door-latch post, next to the driver's seating position), or Tire Label located on the B-Pillar or the edge of the driver door.

* **B-pillar:** The structural member at the side of the vehicle behind the front door.

* **Bead area of the tire:** Area of the tire next to the rim.

* **Sidewall of the tire:** Area between the bead area and the tread.

* **Tread area of the tire:** Area of the perimeter of the tire that contacts the road when mounted on the vehicle.

* **Rim:** The metal support (wheel) for a tire or a tire and tube assembly upon which the tire beads are seated.

TIRE REPLACEMENT REQUIREMENTS

AGE



WARNING: Tires degrade over time depending on many factors such as weather, storage conditions, and conditions of use (load, speed, inflation pressure) the tires experience throughout their lives. In general, tires should be replaced after six years regardless of tread wear. However, heat caused by hot climates or frequent high loading conditions can accelerate the aging process and may require tires to be replaced more frequently.

You should replace your spare tire when you replace the road tires or after six years due to aging even if it has not been used.

U.S. DOT Tire Identification Number

Both United States and Canada Federal regulations require tire manufacturers to place standardized information on the sidewall of all tires. This information identifies and describes the fundamental characteristics of the tire and also provides a U.S. DOT Tire Identification Number for safety standard certification and in case of a recall.

This begins with the letters DOT and indicates that the tire meets all federal standards. The next two numbers or letters are the plant code designating where it was manufactured, the next two are the tire size code and the last four numbers represent the week and

Wheel and Tire Information

year the tire was built. For example, the numbers 317 mean the 31st week of 1997. After 2000, the numbers go to four digits. For example, 2501 means the 25th week of 2001. The numbers in between are identification codes used for traceability. This information is used to contact customers if a tire defect requires a recall.

Tire Replacement Requirements

Your vehicle is equipped with tires designed to provide a safe ride and handling capability.



WARNING: Only use replacement tires and wheels that are the same size, load index, speed rating, and type as those originally provided for your vehicle. The recommended tire and wheel sizes can be found on the Tire Label on the driver side door frame or the edge of the driver door. If this information is not found in

those locations, or for additional options, contact your authorized dealer. Use of any tire or wheel not recommended, could affect the safety and performance of your vehicle, which could result in an increased risk of loss of vehicle control, vehicle rollover, personal injury and death.



WARNING: If your vehicle has 275/50R22 tires, replace them with the exact original brand, and size. Use of any other wheel or tire combinations, even with identical size ratings, could result in insufficient running clearances, tire rubbing and eventual puncture. Failure to follow tire replacement recommendations can lead to tire failure, loss of vehicle control, serious injury or death.





WARNING: If your vehicle has 285/40R24 tires, replace them with the exact original brand, and size. Use of any other wheel or tire combinations, even with identical size ratings, could result in insufficient running clearances, tire rubbing and eventual puncture. Failure to follow tire replacement recommendations can lead to tire failure, loss of vehicle control, serious injury or death.



WARNING: To reduce the risk of serious injury, when mounting replacement tires and wheels, you should not exceed the maximum pressure indicated on the sidewall of the tire to set the beads without additional precautions listed below. If the beads do not seat at the maximum pressure indicated, re-lubricate and try again.

Wheel and Tire Information

 **WARNING:** For a mounting pressure more than 20 psi (1.38 bar) greater than the maximum pressure, a Ford dealer or other tire service professional should do the mounting.

 **WARNING:** Always inflate steel carcass tires with a remote air fill with the person inflating standing at a minimum of 12 ft (3.66 m) away from the wheel and tire assembly.

 **WARNING:** When inflating the tire for mounting pressures up to 20 psi (1.38 bar) greater than the maximum pressure on the tire sidewall, the following precautions must be taken to protect the person mounting the tire:

- Make sure that you have the correct tire and wheel size.
- Lubricate the tire bead and wheel bead seat area again.

- Stand at a minimum of 12 ft (3.66 m) away from the wheel and tire assembly.
- Use both eye and ear protection.

Important: Remember to replace the wheel valve stems when the road tires are replaced on your vehicle.

It is recommended that the two front tires or two rear tires generally be replaced as a pair if the worn tires still have usable depth.

To avoid potential Four-Wheel Drive (4WD) malfunction or (4WD) system damage, it is recommended to replace all four tires rather than mixing significantly worn tires with new tires.

The tire pressure sensors mounted in the wheels (originally installed on your vehicle) are not designed to be used in aftermarket wheels.

The use of wheels or tires not recommended may affect the operation of your tire pressure monitoring system.

If the tire pressure monitoring system indicator is flashing, your system is malfunctioning. Your replacement tire might be incompatible with your tire pressure monitoring system, or some component of the system may be damaged.

USING SNOW CHAINS

 **WARNING:** Do not exceed 30 mph (50 km/h). Failure to follow this instruction could result in the loss of control of your vehicle, personal injury or death.

 **WARNING:** Do not use snow chains on snow-free roads.

 **WARNING:** Only fit snow chains to specified tires.

Wheel and Tire Information



WARNING: If your vehicle is fitted with wheel trims, remove them before fitting snow chains.



WARNING: If you choose to install snow tires on your vehicle, they must be the same size, construction, and load range as the original tires listed on the tire placard, and they must be installed on all four wheels. Mixing tires of different size or construction on your vehicle can adversely affect your vehicle's handling and braking, and may lead to loss of vehicle control.



WARNING: Wheels and tires must be the same size, load index and speed rating as those originally fitted on the vehicle. Use of any other tire or wheel can affect the safety and performance of your vehicle. Additionally, the use of non-recommended tires and wheels can cause steering, suspension, axle, transfer case or power transfer unit failure. Follow the

recommended tire inflation pressures found on the Safety Compliance Certification label, or the Tire Label on the B-Pillar or the edge of the driver door. Failure to follow this instruction could result in loss of vehicle control, vehicle rollover, or personal injury or death.

Only use snow chains on rear wheels. Install snow chains in pairs. Do not use self-tensioning snow chains.

Only use snow chains on the following specified tire sizes. Only install chains that are 15mm or less (SAE Class S chains).

- 265/70R17
- 275/65R18

We recommend you use steel wheels of the same size and specification if snow chains are required because chains may chip aluminum wheels.

Follow these guidelines when using snow tires and traction devices:

- If possible, avoid fully loading your vehicle.
- Purchase snow chains from a manufacturer that clearly labels body to tire dimension restrictions.
- When driving with snow chains do not exceed 30 mph (50 km/h) or the maximum speed recommended by the chain manufacturer, whichever is less.
- Drive cautiously. If you hear the snow chains rub or bang against the vehicle, stop and tighten them. If this does not work, remove the snow chains to prevent vehicle damage.
- Remove the snow chains when they are no longer needed. Do not use snow chains on dry roads.
- If a temporary spare wheel is mounted on your vehicle, do not use snow chains on the axle with the temporary spare wheel.

Wheel and Tire Information

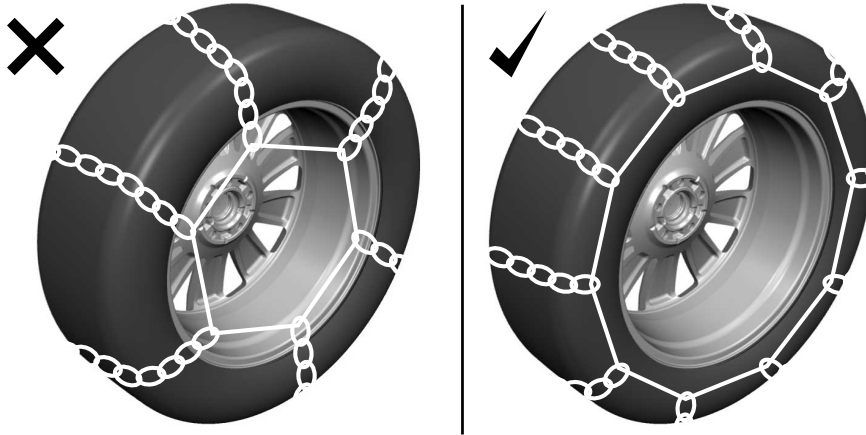

Use snow chains that fit against the sidewall of the tire to prevent the chains from touching the wheel rims or suspension. Refer to the previous illustration.

If you have any questions regarding snow chains, please contact your authorized dealer.

Tire Care

CHECKING THE TIRE PRESSURES

Safe operation of your vehicle requires that your tires are properly inflated. Every day before you drive, check your tires.

At least once a month and before long trips, inspect each tire and check the tire pressure with a tire gauge. Inflate all tires to the recommended inflation pressure. See **Inflating the Tires** (page 437).

INFLATING THE TIRES



WARNING: Under-inflation is the most common cause of tire failures and may result in severe tire cracking, tread separation or blowout, with unexpected loss of vehicle control and increased risk of injury. Under-inflation increases sidewall flexing and rolling resistance, resulting in heat

buildup and internal damage to the tire. It also may result in unnecessary tire stress, irregular wear, loss of vehicle control and accidents. A tire can lose up to half of its air pressure and not appear to be flat!



WARNING: Do not use the tire pressure displayed in the information display as a tire pressure gauge. Failure to follow this instruction could result in personal injury or death.

Use the recommended cold inflation pressure for optimum tire performance and wear. Under-inflation or over-inflation may cause uneven treadwear patterns.

Inflate your tires to the recommended inflation pressure even if it is less than the maximum inflation pressure information found on the tire. You can find the tire label with the recommended tire inflation pressure next to the tire size on the B-Pillar or the edge of the driver door.

The recommended tire inflation pressure is also found on the Safety Compliance Certification Label, affixed to either the door hinge pillar, door-latch post, or the door edge that meets the door-latch on the B-pillar, or on the edge of the driver door.

Failure to follow the tire pressure recommendations can cause uneven treadwear patterns and adversely affect the way your vehicle handles.

Tire Care

Checking Pressure when tires are hot:

If pressures are checked after tires have been driven for more than three minutes or more than 1 mile, (2 km) the tires become hot and the pressures will increase by approximately 4 psi (27.6 kPa). Therefore when the tire pressure is adjusted under these conditions, it should be increased to a gauge reading of 4 psi (27.6 kPa) greater than the recommended cold inflation pressure.

After inflating the tires while hot, make sure to recheck tire pressure later once the tires are cold.

For Example Only

Gauge reading of hot tire	33 psi (230 kPa)
If recommended, cold inflation pressure is	32 psi (220 kPa)

The hot tire pressure is only 1 psi (10 kPa) greater than the recommended cold inflation pressure. Therefore, add 3 psi (20 kPa) more to increase the hot pressure to 4 psi (30 kPa) over the recommended cold inflation pressure.

New hot pressure	36 psi (250 kPa)
------------------	------------------

INSPECTING THE TIRE FOR WEAR

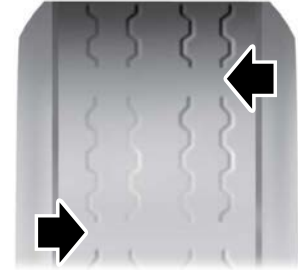

Tire Care

When the tread is worn down to 2/32 inch (1.6 mm), tires must be replaced to help prevent your vehicle from skidding and hydroplaning. Built-in treadwear indicators, or wear bars, which look like narrow strips of smooth rubber across the tread will appear on the tire when the tread is worn down to 2/32 inch (1.6 mm).

When the tire tread wears down to the same height as these wear bars, the tire is worn out and must be replaced.

The tires should also be balanced periodically. An unbalanced tire and wheel assembly may result in irregular tire wear.

Periodically inspect the tire treads for uneven or excessive wear and remove objects such as stones, nails or glass that may be wedged in the tread grooves.

INSPECTING THE TIRE FOR DAMAGE

Inspect the tire sidewalls for cracking, cuts, bruises and other signs of damage or excessive wear. If internal damage to the tire is suspected, have the tire dismantled and inspected in case it needs to be repaired or replaced. For your safety, tires that are damaged or show signs of excessive wear should not be used because they are more likely to blow out or fail.

Periodically inspect the tire treads and sidewalls for damage, such as bulges in the tread or sidewalls, cracks in the tread groove and separation in the tread or sidewall. If damage is observed or suspected, have the tire inspected by a tire professional.

Safety Practices



WARNING: If your vehicle is stuck in snow, mud or sand, do not rapidly spin the tires; spinning the tires can tear the tire and cause an explosion. A tire can explode in as little as three to five seconds.



WARNING: Do not spin the wheels at over 34 mph (55 km/h). The tires may fail and injure a passenger or bystander.

Tire Care

HIGH SPEED DRIVING CAN BE DANGEROUS

Correct inflation pressure is especially important. However, at high speeds, even with the correct inflation pressure, a road hazard for example is more difficult to avoid and if contact is made, has a greater chance of causing tire damage than at a lower speed. Moreover, driving at high speed reduces the reaction time available to avoid accidents and bring your vehicle to a safe stop.

If you see any damage to a tire or wheel, replace it with the spare at once and visit a participating Tire Retailer.

Exceeding the maximum speeds shown on the following page for each type of tire will cause the tire to build up excessive heat which can cause tire damage that could result in sudden tire destruction and rapid air loss. Failure to control a vehicle when one or more tires experience a sudden air loss can lead to an accident.

In any case, you should not exceed reasonable speeds as indicated by the legal limits and driving conditions.

DO NOT OVERLOAD: DRIVING ON ANY OVERLOADED TIRE IS DANGEROUS

The maximum load rating of your tires is molded on the tire sidewall. Do not exceed this rating. Follow the loading instructions of the manufacturer of your vehicle and this will ensure that your tires are not overloaded. Tires which are loaded beyond their maximum

allowable loads for the particular application will build up excessive heat that may result in sudden tire destruction. Do not exceed the gross axle weight rating for any axle on your vehicle.

TIRE ALTERATIONS

Do not make or allow to be made any alterations on your tires. Alterations may prevent proper performance, leading to tire damage which can result in an accident. Tires which become unserviceable due to alterations such as truing, whitewall inlays, addition of balancing or sealant liquids, or the use of tire dressing containing petroleum distillates are excluded from warranty coverage.

Tire Care

REPAIRS - WHEREVER POSSIBLE, SEE YOUR TIRE RETAILER AT ONCE

If any tire sustains a puncture, have the tire demounted and thoroughly inspected by a tire retailer for possible damage that may have occurred. A tread area puncture in any passenger or light truck tire can be repaired provided that the puncture hole is not more than 1/4" in diameter, not more than one radial cable per casing ply is damaged, and the tire has not been damaged further by the puncturing object or by running underinflated. Tire punctures consistent with these guidelines should only be repaired by following the US Tire Manufacturers Association (USTMA) recommended repair procedures. Plug-only repairs done on-the-wheel are considered improper and therefore, not recommended. Such repairs are not reliable and may cause further damage to the tire.

STORAGE

Tires contain waxes and emollients to protect their outer surfaces from ozone and weather checking. As the tire rolls and flexes, the waxes and emollients continually migrate to the surface, replenishing this protection throughout the normal use of the tire. Consequently, when tires sit unused for long periods of time (a month or more) their surfaces become dry and more susceptible to ozone and weather checking and the casing becomes susceptible to flat spotting. **For this reason, tires should always be stored in a cool, dry, clean, indoor environment. If storage is for one month or more, eliminate the weight from the tires by raising the vehicle or by removing the tires from the vehicle. Failure to store tires in accordance with these instructions could result in damage to your tires or premature aging of the tires and sudden tire failure.**

When tires are stored, be sure they are placed away from sources of heat and ozone such as direct sunlight, hot pipes and electric generators. Be sure that surfaces on which tires are stored are clean and free from grease, gasoline or other substances, which could deteriorate the rubber. Failure to store tires in accordance with these instructions could result in damage to your tires or premature aging of the tires and sudden tire failure.

FOLLOW THESE MOUNTING RECOMMENDATIONS

Tire changing can be dangerous and must be done by professionally trained persons using proper tools and procedures as specified by the US Tire Manufacturers Association (USTMA). Single or dual assemblies must be completely deflated before demounting.

Tire Care

Your tires should be mounted on wheels of correct size and type and which are in good, clean condition. Wheels that are bent, chipped, rusted (steel wheels) or corroded (alloy wheels) may cause tire damage. The inside of the tire must be free from foreign material. Have your retailer check the wheels before mounting new tires. Mismatched tires and rims can explode during mounting. Also, mismatched tires and rims can result in dangerous tire failure on the road. If a tire is mounted by error on the wrong-sized rim, do not remount it on the proper rim - scrap it. It may have been damaged internally (which is not externally visible) by having been dangerously stretched and could fail on the highway.

Old valves may leak. When new tubeless tires are mounted, have new valves of the correct type installed. Tubeless tires must only be mounted on wheels designed for tubeless tires i.e., wheels which have safety humps or ledges.

It is recommended that you have your tires and wheels balanced. Tires and wheels, which are not balanced, may cause steering difficulties, a bumpy ride, and irregular tire wear.

Be sure that all your valves have suitable valve caps. The valve cap is the primary seal against air loss.

TEMPORARY SPARE TIRES

When using any temporary spare tire, be sure to follow the vehicle manufacturer's instructions.

REMEMBER... TO AVOID DAMAGE TO YOUR TIRES AND POSSIBLE ACCIDENT:

- CHECK TIRE PRESSURE AT LEAST ONCE EACH MONTH WHEN TIRES ARE COLD AND BEFORE LONG TRIPS.
- DO NOT UNDERINFLATE/OVERINFLATE.
- DO NOT OVERLOAD.
- DRIVE AT MODERATE SPEEDS, OBSERVE LEGAL LIMITS.
- AVOID DRIVING OVER POTHoles, OBSTACLES, CURBS OR EDGES OF PAVEMENT.
- AVOID EXCESSIVE WHEEL SPINNING.

Tire Care

- IF YOU SEE ANY DAMAGE TO A TIRE, REPLACE WITH THE SPARE AND VISIT ANY AUTHORIZED RETAILER AT ONCE.
- IF YOU HAVE ANY QUESTIONS, CONTACT YOUR AUTHORIZED RETAILER.

Highway Hazards

No matter how carefully you drive, there is always the possibility that you could eventually have a flat tire on the highway. Drive slowly to the closest safe area out of traffic. This could further damage the flat tire, but your safety is more important.

If you feel a sudden vibration or ride disturbance while driving, or you suspect your tire or vehicle has been damaged, immediately reduce your speed. Drive with caution until you can safely pull off the road. Stop and inspect the tires for damage. If a tire is under-inflated or damaged,

deflate it, remove the wheel and replace it with your spare tire and wheel. If you cannot detect a cause, have the vehicle towed to the nearest repair facility or tire dealer to have the vehicle inspected.

Tire and Wheel Alignment

A bad jolt from hitting a curb or pothole can cause the front end of your vehicle to become misaligned or cause damage to your tires. If your vehicle seems to pull to one side when you are driving, the wheels could be out of alignment. Have an authorized dealer check the wheel alignment periodically.

Wheel misalignment in the front or the rear can cause uneven and rapid treadwear of your tires and should be corrected by an authorized dealer.

INSPECTING THE WHEEL VALVE STEMS

Check the valve stems for holes, cracks, or cuts that could permit air leakage.

TIRE ROTATION



WARNING: If the tire label shows different tire pressures for the front and rear tires and the vehicle has a tire pressure monitoring system, then you need to update the settings for the system sensors. Always perform the system reset procedure after tire rotation. If you do not reset the system, it may not provide a low tire pressure warning when necessary.

Tire Care

Rotating your tires at the recommended interval will help your tires wear more evenly, providing better tire performance and longer tire life.

Note: *If your tires show any uneven wear have the alignment checked by an authorized dealer before rotating tires.*

Note: *If you have a dissimilar spare wheel and tire assembly, it is intended for temporary use only and should not be used in a tire rotation.*

Note: *After having your tires rotated, inflation pressure must be checked and adjusted to the vehicle requirements.*

Tire Rotation Diagram

Follow the diagram indicating the correct tire locations for rotating the tires.

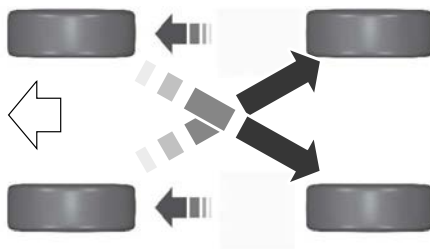

Tire Pressure Monitoring System

WHAT IS THE TIRE PRESSURE MONITORING SYSTEM



The tire pressure monitoring system measures the vehicle's tire pressures. A warning lamp illuminates if one or more tires are significantly underinflated or if there is a system malfunction.

TIRE PRESSURE MONITORING SYSTEM OVERVIEW



WARNING: Under-inflation is the most common cause of tire failures and may result in severe tire cracking, tread separation or blowout, with unexpected loss of vehicle control and increased risk of injury. Under-inflation increases sidewall flexing and rolling resistance, resulting in heat buildup and internal damage to the tire. It also may result in unnecessary tire stress, irregular wear, loss of vehicle control and accidents. A tire can lose up to half of its air pressure and not appear to be flat!



WARNING: To determine the required pressure(s) for your vehicle, see the Safety Compliance Certification Label (on the door hinge pillar, door-latch post or the door edge that meets the door-latch post, next to the driver seat) or the Tire Label on the B-Pillar or the edge of the driver door.

Each tire, including the spare (if provided), should be checked monthly when cold and inflated to the inflation pressure recommended by the vehicle manufacturer on the vehicle placard or tire inflation pressure label. (If your vehicle has tires of a different size than the size indicated on the vehicle placard or tire inflation pressure label, you should determine the proper tire inflation pressure for those tires).

As an added safety feature, your vehicle has been equipped with a Tire Pressure Monitoring System (TPMS) that illuminates a low tire pressure telltale when one or more of your tires is significantly under-inflated. Accordingly, when the low tire pressure telltale illuminates, you should stop and check your tires as soon as possible, and

inflate them to the proper pressure. Driving on a significantly under-inflated tire causes the tire to overheat and can lead to tire failure. Under-inflation also reduces fuel efficiency and tire tread life, and may affect the vehicle's handling and stopping ability.

Please note that the TPMS is not a substitute for proper tire maintenance, and it is the driver's responsibility to maintain correct tire pressure, even if under-inflation has not reached the level to trigger illumination of the TPMS low tire pressure telltale.

Your vehicle has also been equipped with a TPMS malfunction indicator to indicate when the system is not operating properly. The TPMS malfunction indicator is combined with the low tire pressure telltale. When the system detects a malfunction, the telltale will flash for approximately one minute and then remain continuously illuminated. This sequence will continue upon subsequent vehicle start-ups as long as the malfunction exists.

When the malfunction indicator is illuminated, the system may not be able to detect or signal low tire pressure as intended. TPMS malfunctions may occur for a variety of reasons, including the installation of replacement or alternate tires or wheels on the vehicle that prevent the TPMS from

Tire Pressure Monitoring System

functioning properly. Always check the TPMS malfunction telltale after replacing one or more tires or wheels on your vehicle to ensure that the replacement or alternate tires and wheels allow the TPMS to continue to function properly.

 **WARNING:** Changes or modifications not expressly approved by the party responsible for compliance could void the user's authority to operate the equipment. The term "IC:" before the radio certification number only signifies that Industry Canada technical specifications were met.

This device complies with Part 15 of the FCC Rules and with License exempt RSS Standards of Industry Canada. Operation is subject to the following two conditions:

1. This device may not cause harmful interference, and
2. This device must accept any interference received, including interference that may cause undesired operation.

TIRE PRESSURE MONITORING SYSTEM PRECAUTIONS

 **WARNING:** The tire pressure monitoring system is not a substitute for manually checking tire pressures. You should periodically check tire pressures using a pressure gauge. Failure to correctly maintain tire pressures could increase the risk of tire failure, loss of control, vehicle rollover and personal injury.

 **WARNING:** Do not use the tire pressure displayed in the information display as a tire pressure gauge. Failure to follow this instruction could result in personal injury or death.

Note: *The use of tire sealants can damage the tire pressure monitoring system.*

Note: *If the tire pressure monitor sensor becomes damaged it may not function.*

TIRE PRESSURE MONITORING SYSTEM LIMITATIONS

When the outside temperature drops significantly, the tire pressure could decrease and activate the low tire pressure warning lamp.

The warning lamp could also illuminate when you use a spare wheel, or tire sealant from the inflator kit.

Note: *Regularly checking the vehicle tire pressures can reduce the possibility for the warning lamp to illuminate due to outside air temperature changes.*

Note: *After you inflate the tires to the recommended pressure it could take up to two minutes of driving over 20 mph (32 km/h) for the warning indicator to turn off.*

Tire Pressure Monitoring System

VIEWING THE TIRE PRESSURES



Using the instrument cluster display arrow keys navigate to the truck info section where you can view the tire pressures.

RESETTING TIRE PRESSURE MONITORING SYSTEM

Tire Pressure Monitoring System Reset Procedure



WARNING: To determine the required pressure(s) for your vehicle, see the Safety Compliance Certification Label (on the door hinge pillar, door-latch post or the door edge that meets the door-latch post, next to the driver seat) or the Tire Label on the driver or passenger side B-pillar, or the edge of the driver door.

You must reset the tire pressure monitoring system after each tire rotation on vehicles that require different recommended tire pressures in the front tires as compared to the rear tires.

Note: To reduce the chances of interference from another vehicle, perform the system reset procedure at least three feet, one meter, away from another vehicle undergoing the system reset procedure at the same time.

Note: Do not wait more than two minutes between resetting each tire sensor or the system can time-out and you need to repeat the entire procedure on all four wheels.

1. Drive the vehicle above 20 mph (32 km/h) for at least two minutes, then park in a safe location where you can easily get to all four tires and have access to an air pump.
2. Switch the ignition off.
3. Switch the ignition on but do not start the engine.
4. Switch the hazard flashers on then off three times.

Note: You must accomplish this within 10 seconds. If you successfully enter the reset mode, the horn sounds once, the system indicator flashes and a message shows in the information display.

Note: If the system does not enter reset mode, try again starting at Step 2. If after repeated attempts to enter the reset mode, the horn does not sound, the system indicator does not flash and no message shows in the information display, contact your authorized dealer.

5. Remove the valve cap from the valve stem on the left front tire. Decrease the air pressure until the horn sounds.

Tire Pressure Monitoring System

Note: The single horn tone confirms that the sensor identification code has been learned by the module for this position. If the horn sounds twice, the reset procedure was unsuccessful, and you must repeat it.

6. Remove the valve cap from the valve stem on the right front tire. Decrease the air pressure until the horn sounds.
7. Repeat the previous step on the right rear tire and then on the left rear tire.

8. Switch the ignition off.

Note: If the horn sounds twice again after switching the ignition off, and repeating the procedure, contact your authorized dealer and have your vehicle checked as soon as possible.

9. Set all four tires to the recommended air pressure as indicated on the Safety Compliance Certification Label.

TIRE PRESSURE MONITORING SYSTEM – TROUBLESHOOTING

TIRE PRESSURE MONITORING SYSTEM – WARNING LAMPS



The low tire pressure warning lamp has combined functions, as it warns you when your tires need air, and when the system is no longer capable of functioning as intended.

Warning Lamp	Possible Cause	Action Required
Solid warning lamp	One or more tires are significantly under inflated	After inflating your tires to the manufacturer's recommended pressure as shown on the tire label, on the edge of driver door or the B-pillar, drive your vehicle for at least two minutes over 20 mph (32 km/h) before the light turns off.
	Tire rotation without sensor training	On vehicles with different front and rear tire pressures, the system must be retrained following every tire rotation.
Solid warning lamp or flashing warning lamp	Temporary spare wheel in use	Repair the damaged road wheel and tire and refit it to your vehicle to restore operation of the system.
	Tire pressure monitoring system malfunction	If the tires are inflated to the recommended tire pressures and the temporary spare wheel is not in use, the system detected a fault that requires service. Have your vehicle checked as soon as possible.

Tire Pressure Monitoring System

TIRE PRESSURE MONITORING SYSTEM – INFORMATION MESSAGES

Message	Details
Tire Pressure Low	After inflating your tires to the manufacturer’s recommended pressure as shown on the Tire Label, on the edge of the driver door or the B-Pillar, drive your vehicle for at least two minutes over 20 mph (32 km/h) before the light turns off.
Tire Pressure Monitor Fault	The system has detected a fault that requires service. Have your vehicle checked as soon as possible.
Tire Pressure Sensor Fault	The system has detected a fault that requires service or a spare tire is in use. Have your vehicle checked as soon as possible.

Changing a Road Wheel

CHANGING A FLAT TIRE

If you get a flat tire when driving, do not apply the brake heavily. Instead, gradually decrease your speed, hold the steering wheel firmly and slowly move to a safe place on the side of the road.

Have the flat serviced by an authorized dealer to prevent damage to the system sensors. See **Tire Pressure Monitoring System** (page 445). Replace the spare tire with a road tire as soon as possible. During repairing or replacing of the flat tire, have the authorized dealer inspect the system sensor for damage.

Note: Only use tire sealants in roadside emergencies as they may cause damage to the tire pressure monitoring system sensor.

Note: The tire pressure monitoring system indicator illuminates when the spare tire is in use. To restore the full function of the tire pressure monitoring system, all road wheels with tire pressure monitoring sensors must be mounted on this vehicle.

Dissimilar Spare Wheel and Tire Assembly Information



WARNING: Failure to follow these guidelines could result in an increased risk of loss of vehicle control, injury or death.

If you have a dissimilar spare wheel and tire, then it is intended for temporary use only. This means that if you need to use it, you should replace it as soon as possible with a road wheel and tire assembly that is the same size and type as the road tires and wheels that were originally provided. If the dissimilar spare tire or wheel is damaged, it should be replaced rather than repaired.

A dissimilar spare wheel and tire assembly is defined as a spare wheel and tire assembly that is different in brand, size or appearance from the other road tires and wheels on your vehicle.

Full-size dissimilar spare

When driving with the full-size dissimilar spare wheel and tire assembly, do not:

- Exceed 70 mph (113 km/h).
- Use more than one dissimilar spare wheel and tire assembly at a time.
- Use snow chains on the end of the vehicle with the dissimilar spare wheel and tire assembly.

When driving with the full-size dissimilar spare wheel and tire assembly, it is recommended that you do not:

- Exceed 50 mph (80 km/h) in four-wheel drive.
- Engage four-wheel drive unless the vehicle is stationary.
- Use four-wheel drive on dry pavement.

Using a dissimilar spare wheel and tire assembly can compromise the effectiveness of the following:

- Handling, stability and braking performance.
- Comfort and noise.
- Ground clearance and parking at curbs.
- Winter weather driving capability.
- Wet weather driving capability.
- Four-wheel driving capability.

Changing a Road Wheel

When driving with the full-size dissimilar spare wheel and tire assembly additional caution should be given to:

- Towing a trailer.
- Driving vehicles equipped with a camper body.

- Driving vehicles with a load on the cargo rack.

Drive cautiously when using a full-size dissimilar spare wheel and tire assembly and seek service as soon as possible.

Location of the Spare Tire and Tools

The spare tire is located under the vehicle, just forward of the rear bumper. The jack, swivel wrench and lug wrench are in the following locations:

Item	Location
Spare tire	Under the vehicle, just forward of the rear bumper.
Jack and tool kit bag	Under the access panel located in the floor compartment behind the rear seat.

Tire Change Procedure



WARNING: Only use replacement tires and wheels that are the same size, load index, speed rating, and type as those originally provided for your vehicle. The recommended tire and wheel sizes can be found on the Tire Label on the driver side door frame or the edge of the driver door. If this information is not found in those locations, or for additional options, contact

your authorized dealer. Use of any tire or wheel not recommended, could affect the safety and performance of your vehicle, which could result in an increased risk of loss of vehicle control, vehicle rollover, personal injury and death.



WARNING: To help prevent your vehicle from moving when changing a wheel, shift the transmission into park (P), set the parking brake and use an appropriate block or wheel chock to secure the wheel diagonally opposite to the wheel being changed. For example, when changing the front left wheel, place an appropriate block or wheel chock on the right rear wheel.



WARNING: Only use the jack provided as original equipment with your vehicle.

Changing a Road Wheel

WARNING: Switch off the running boards before jacking or placing any object under your vehicle. Never place your hand between the extended running board and your vehicle. A moving running board may cause injury.

WARNING: Only use the spare wheel carrier to stow wheels provided with your vehicle.

WARNING: Ensure screwthread is adequately lubricated before use.

WARNING: Apply the parking brake, shift into park (P), switch the ignition off and remove the key before you leave your vehicle. Failure to follow this instruction could result in personal injury or death.

WARNING: Only use the specified jacking points. If you use any other locations you could damage vehicle components, such as brake lines.

WARNING: Do not attempt to change a tire on the side of the vehicle close to moving traffic. Pull far enough off the road to not obstruct the flow of traffic and avoid the danger of being hit when operating the jack or changing the wheel.

1. Park the vehicle on firm, level ground and activate the hazard flashers.
2. Apply the parking brake, place the transmission in park (P) and switch the ignition off.
3. Block the wheels diagonally opposite the flat tire, for example, if the left front tire is flat, block the right rear wheel.

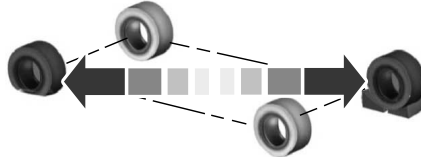

Removing the Jack and Tools

1. Open the liftgate and lift the load floor behind the third row seat. If your vehicle has an access panel, unlatch and remove this panel.
2. Loosen the straps and remove the tool bag from the jack.
3. Loosen the jack screw to remove the preload.
4. Remove the wing nut by turning it counterclockwise, then remove the jack from the bracket.



Note: Pay close attention to the orientation of the jack and tool kit bag, because it needs to be reinstalled after changing the tire.

Changing a Road Wheel

Removing the Spare Tire

1. Remove the swivel wrench from the tool kit bag, open the spare tire winch access plug at the bottom of the compartment for the jack and tools tray.
2. Insert the swivel wrench through the access hole in the floor to engage the winch. Turn the handle counterclockwise until the tire lowers to the ground and the cable is loose.

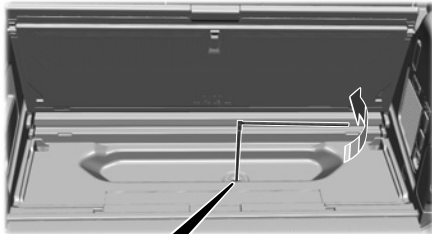

3. Slide the retainer through the center of the spare tire wheel and remove the spare tire.

Note: *If your wheel nuts are hidden, use the lug wrench tip to remove the wheel ornament to access the wheel nuts.*

4. Loosen each wheel lug one-half turn counterclockwise, but do not remove them until the wheel is off the ground.



Jacking the Vehicle

WARNING: No person should place any portion of their body under a vehicle that is supported by a jack.

WARNING: The jack supplied with this vehicle is only intended for changing a flat tire in an emergency. Do not attempt to do any other work on your vehicle when it is supported by the jack, as your vehicle could slip off the jack. Failure to follow this instruction could result in personal injury or death.

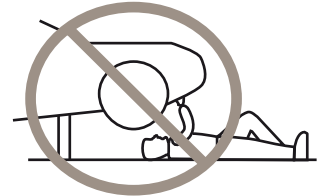

Changing a Road Wheel

WARNING: The jack supplied with this vehicle is only intended for changing a flat tire in an emergency. Do not attempt to do any other work on your vehicle when it is supported by the jack, as your vehicle could slip off the jack. Failure to follow this instruction could result in personal injury or death.

WARNING: The jack should be used on level firm ground wherever possible.

WARNING: Never place anything between the vehicle jack and the ground.

WARNING: Never place anything between the vehicle jack and your vehicle.

WARNING: It is recommended that the wheels of the vehicle be chocked, and that no person should remain in a vehicle that is being jacked.

WARNING: Failure to follow these guidelines could result in an increased risk of loss of vehicle control, injury or death.

Note: Both the front and rear jacking points are on the frame rails. The correct locations on the frame rails are marked with an arrow punched into the frame rail. Jack at the specified locations to avoid damaging your vehicle.

Front jacking point

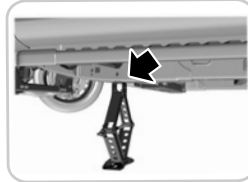
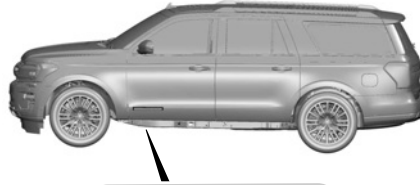

Rear jacking point

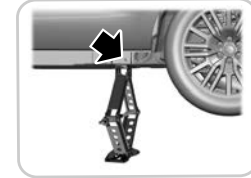

1. Position the jack at the jacking point indicator arrow closest to the flat tire location. Assemble the jack drive extension to the lug wrench as shown and use it to turn the jack drive clockwise to raise the vehicle until the flat tire is completely off the ground.

Note: The jack does not require maintenance or additional lubrication over the life of your vehicle.

Changing a Road Wheel



2. Remove the lug nuts with the lug wrench. Replace the flat tire with the spare tire, making sure the valve stem is facing outward.
3. Reinstall the lug nuts until the wheel is snug against the hub. Do not fully tighten the lug nuts until the wheel has been lowered.
4. Completely lower the vehicle by turning the jack drive counterclockwise.
5. Remove the jack and fully tighten the lug nuts in the order shown. See **Wheel Nuts** (page 456).

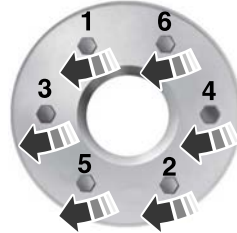

Stowing the Flat or Spare Tire

1. Lay the tire on the ground, near the rear of the vehicle, with the valve stem side facing up.
2. Slide the wheel partially under the vehicle and install the retainer through the wheel center. You may have to remove the wheel center cap prior to pushing the retainer through the center of the wheel. To remove the center cap, press it off with the jack tool from the inner side of the wheel. Pull on the cable to align the components at the end of the cable.
3. Using the swivel wrench, insert it through the access hole behind the third row seat and engage the winch.
4. Turn the swivel wrench clockwise until the tire is raised to its stowed position underneath the vehicle. The wrench becomes harder to turn and the spare tire winch ratchets or slips when the tire is raised to maximum tightness. A clicking sound can be heard from the winch indicating that the tire is properly stowed.
5. Carefully place all tools back into the tool kit bag.
6. Reinstall the tool kit bag on the jack and tighten the straps.
7. Reinstall the jack properly on the bracket and secure with the wing nut.
8. Close the access hole with the rubber plug.
9. If the vehicle has an access panel, reinstall.
10. Unblock the wheel.

Changing a Road Wheel

WHEEL NUTS



WARNING: When you install a wheel, always remove any corrosion, dirt or foreign materials present on the mounting surfaces of the wheel or the surface of the wheel hub, brake drum or brake disc that contacts the wheel. Make sure to secure any fasteners that attach the rotor to the hub so they do not interfere with the mounting surfaces of the wheel. Installing wheels without correct metal-to-metal contact at the wheel mounting surfaces can cause the wheel nuts to loosen and the wheel to come off while your vehicle is in motion, resulting in loss of vehicle control, personal injury or death.

Retighten the wheel nuts to the specified torque within 100 mi (160 km) after any wheel disturbance, such as tire rotation, changing a flat tire or wheel removal.



A Hub pilot bore.

Inspect the wheel pilot hole and mounting surface prior to installation. Remove any visible corrosion or loose particles.

Bolt Size	lb.ft (Nm) ¹
M14 x 1.5	150 lb.ft (204 Nm)

¹ Torque specifications are for nut and bolt threads free of dirt and rust. Use only our recommended replacement wheel nuts and or wheel bolts.

Vehicle Identification

VEHICLE IDENTIFICATION NUMBER

LOCATING THE VEHICLE IDENTIFICATION NUMBER

The vehicle identification number is located on the left-hand side of the instrument panel.

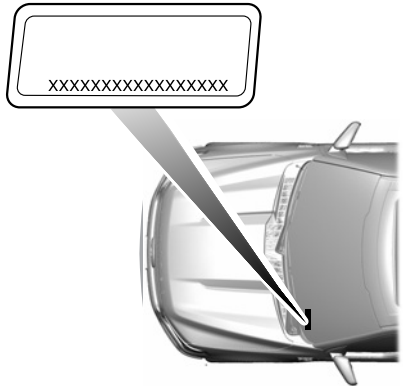

In the graphic, XXXX is representative of your vehicle identification number.

VEHICLE IDENTIFICATION NUMBER OVERVIEW

The vehicle identification number contains the following information:

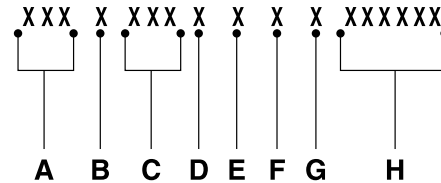

- A World manufacturer identifier.
- B Brake system, gross vehicle weight rating, restraint devices and their locations.
- C Make, vehicle line, series, body type.
- D Engine or motor type.
- E Check digit.
- F Model year.
- G Assembly plant.
- H Production sequence number.

Connected Vehicle

WHAT IS A CONNECTED VEHICLE

A connected vehicle has technology that allows your vehicle to connect to a mobile network and for you to access a range of features. When used in conjunction with the Ford mobile app, it could allow you to monitor and control your vehicle further, for example checking the tire pressures, the fuel level and the vehicle location. For additional information, refer to the local Ford website.

CONNECTED VEHICLE REQUIREMENTS

Connected service and related feature functionality requires a compatible vehicle network.

Some remote features require additional service activation. Log in to your Ford account for details. Some restrictions, third party terms and message or data rates may apply.

CONNECTED VEHICLE LIMITATIONS

Evolving technology, cellular networks, or regulations could affect functionality and availability, or continued provision of some features. These changes could even stop some features from functioning.

CONNECTING THE VEHICLE TO A MOBILE NETWORK

WHAT IS THE MODEM



The modem allows access to a range of features built into your vehicle.

ENABLING AND DISABLING THE MODEM

1. From the settings menu, press Network & Internet.
2. Switch Vehicle Connectivity on or off.

CONNECTING FORDPASS TO THE MODEM

1. Make sure that the modem is enabled using the vehicle settings menu.
2. Open the FordPass app on your device and log in.
3. Add your vehicle or select your vehicle if already added.
4. Select the option to activate your vehicle.
5. Make sure that the name on the screen matches the name shown in your FordPass account.
6. Confirm that FordPass account is connected to the modem.

CONNECTING THE VEHICLE TO A WI-FI NETWORK

1. From the settings menu, press Network & Internet.
2. Press Wi-Fi.
3. Switch Wi-Fi on.
4. Select an available Wi-Fi network.

Note: Enter the network password to connect to a secure network.

Connected Vehicle

CONNECTED VEHICLE SETTINGS

From the settings menu, press Privacy and Data Sharing.

You can adjust several settings, such as:

- Share vehicle data.
- Share vehicle location.
- Share driving data.

Note: Depending on your vehicle, different options may be available.

Note: Editing connectivity settings could result in some features not operating correctly or at all. When you edit connectivity settings, pop-up messages may appear to notify you that services will not work without that setting. If you switch a feature on, pop-up messages could appear informing you of the settings that will be turned on. Some features, for example driver assistance features, use map data. We recommend having all connected vehicle settings enabled to allow the map content to be updated to the latest version.



Press the button next to a menu option for more information.

CONNECTED VEHICLE – TROUBLESHOOTING

CONNECTED VEHICLE – FREQUENTLY ASKED QUESTIONS

Why is my Ford mobile app not connecting to my vehicle?

- The modem is not enabled. Switch vehicle connectivity on.
- The network signal is weak. Move your vehicle closer to a place where the network signal is not obstructed.

Why can I not connect to a Wi-Fi network?

- You entered the wrong network password. Enter the correct password.
- The network signal is weak. Move your vehicle closer to the Wi-Fi router or to a place where the network signal is not obstructed.
- There are multiple access points in range with the same network name. Choose a unique name for your network. Do not use the default name unless it contains a unique identifier, for example as part of the MAC address.

Why does the Wi-Fi connection disconnect after successful connection?

- The network signal is weak. Move your vehicle closer to the Wi-Fi router or to a place where the network signal is not obstructed.

What can I do if I am close to a Wi-Fi router but the network signal strength is weak?

- If your vehicle has a heated windshield, position your vehicle so that the windshield is not facing the Wi-Fi router.
- If your vehicle has metallic tinting on the windows but not on the windshield, position your vehicle so that the windshield is facing the Wi-Fi router or open the windows that are facing the router.
- If your vehicle has metallic tinting on the windows and the windshield, open the windows that are facing the router.
- If your vehicle is in a garage and you have the garage door closed, open the garage door as it could block the signal.

Connected Vehicle

Why can I not see a network I expect to see in the list of available networks?

- The network is hidden. Make the network visible and try again, or manually add a network in the Wi-Fi settings menu.
- Some network security types are not supported, for example WEP.

Why do software downloads take too long?

- The network signal is weak. Move your vehicle closer to the Wi-Fi router or to a place where the network signal is not obstructed.
- Wi-Fi network is in high demand or has a slow Internet connection. Use a more reliable Wi-Fi network.

Why does the software not update when the system seems to connect to a Wi-Fi network and the signal strength is excellent?

- No software update is available at this time.
- Select automatic updates option in the settings menu to enable automatic software update or contact an authorized dealer.
- There could be a connection problem. Test the network using another device.

Vehicle Hotspot

SETTING UP A VEHICLE HOTSPOT

With a data plan, your hotspot can provide devices in and around your vehicle with Wi-Fi data.

Note: *A mobile device is required to complete hotspot setup.*

1. From the apps menu, press Hotspot. See **Center Display** (page 469).
2. Scan the code on the touchscreen with your device or follow the text instructions on the touchscreen.
3. Follow the instructions on your device to purchase a plan or start a trial.

If you are not given an option to purchase a plan or start a trial:

- Log into your vehicle's mobile app to access Connected Services.
- Open a new website on your device to access the network carrier's website.

Through the Connected Services portal or your carrier's website, you can manage your account settings such as renewing your plan, purchasing more data, and removing the hotspot from your vehicle.

Note: *Hotspot services are subject to coverage and availability.*

Using the Vehicle Hotspot

Use your device to select the hotspot from the list of Wi-Fi networks.

If the vehicle hotspot name does not show up in the list of available Wi-Fi networks on your device:

- Make sure hotspot visibility is switched on.
- The hotspot is transmitting at a frequency the device can see.

Note: *You cannot connect your device to the vehicle hotspot if it does not support the selected frequency band.*

VEHICLE HOTSPOT SETTINGS

You can change the following in the vehicle hotspot settings menu:

- Vehicle hotspot name or password.
- Vehicle hotspot frequency.

Changing the Vehicle Hotspot Name or Password

The hotspot information can only be updated once you activate the hotspot.

1. From the apps menu, press Hotspot.
2. Press settings.
3. Press Network name.
4. Enter your required network name.
5. Press Enter.
6. Press Password.
7. Enter your required password.
8. Press Enter.

Changing the Vehicle Hotspot Frequency

The vehicle hotspot frequency band is selectable depending upon your device capabilities. You cannot connect your device to the vehicle hotspot if it does not support the selected frequency band.

1. From the apps menu, press Hotspot.
2. Press settings.
3. Press Frequency.
4. Select a frequency.

Audio System

AUDIO SYSTEM PRECAUTIONS



WARNING: Driving while distracted can result in loss of vehicle control, crash and injury. We strongly recommend that you use extreme caution when using any device that may take your focus off the road. Your primary responsibility is the safe operation of your vehicle. We recommend against the use of any hand-held device while driving and encourage the use of voice-operated systems when possible. Make sure you are aware of all applicable local laws that may affect the use of electronic devices while driving.

Listening to loud audio for long periods of time could damage your hearing.

SWITCHING THE AUDIO UNIT ON AND OFF



Press the button on the volume control.

SELECTING THE AUDIO SOURCE

Home Screen View

From the apps menu, press your preferred audio source.

Note: Available audio sources are listed on the Apps menu.

Now Playing View

Press the Audio Source dropdown menu and scroll through the audio sources.

MEDIA CONTROL BUTTONS



Press to play a track. Press again to pause the track.

Note: Not all sources can be paused.



Press the button to skip to the next track.

Press and hold the button to fast forward through the track.



Press the button once to return to the beginning of a track. Repeatedly press the button to return to previous tracks.

Press and hold the button to fast rewind through the track.



Press the button on the touchscreen to switch shuffle mode on or off.

Note: Not all sources have shuffle mode.



Press the button on the touchscreen to change repeat mode.

Note: Not all sources have repeat mode.

Audio System

ADJUSTING THE VOLUME

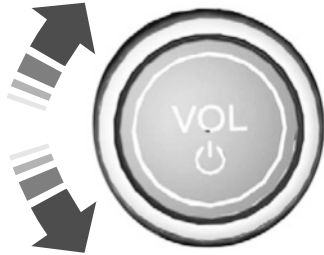

Turn to adjust the volume.

Some vehicles may be able to adjust the volume using buttons on the steering wheel.

SETTING A MEMORY PRESET

1. Select a station or channel.

2. Press the memory preset button on the touchscreen.

Note: *The audio mutes briefly while the system saves the preset and returns once it is stored.*

Note: *You can save presets from multiple sources to the memory preset bar.*

LOCKING THE REAR PASSENGER AUDIO CONTROLS

(IF EQUIPPED)

To access the rear audio lockout menu:

1. From the controls menu, press Parental controls.
2. Switch Rear audio lock or unlock.

ADJUSTING THE SOUND SETTINGS

1. From the settings menu, press Sound.

From the menu, you can adjust the following:

- Tone.
- Balance and fade.
- Speed compensated volume.

- Occupancy mode/Sound mode.
- Volume settings.

Note: *Depending on your vehicle options, not all settings are available.*

SETTING THE CLOCK AND DATE

Clock Settings

To access clock settings:

1. From the settings menu, press System.
2. Press Time.

From the menu you can do the following:

- Have the system automatically set the time zone.
- Manually select a time zone.
- Switch the displayed time between 12 or 24-hour formats.

Note: *Manual time zone selection is only available if automatic time zone is switched off.*

Audio System

AM/FM RADIO

AM/FM RADIO LIMITATIONS

The further you travel from an AM or FM station, the weaker the signal and the weaker the reception.

Hills, mountains, tall buildings, bridges, tunnels, freeway overpasses, parking garages, dense tree foliage and thunderstorms can interfere with the reception.

When you pass a ground-based broadcast repeating tower, a stronger signal may overtake a weaker one and result in the audio system muting.

SELECTING AN AM/FM RADIO STATION

Manually Selecting a Radio Station



Press the button on the radio tuner to go up the frequency band.



Press the button on the radio tuner to go down the frequency band.

Using Seek



Press to seek the next station up the frequency band.

Press and hold to quickly seek up the frequency band.



Press to seek the next station down the frequency band.

Press and hold to quickly seek down the frequency band.

Using the Station List

1. Press the search button on the radio screen.
2. Press a radio station from the list.

DIGITAL RADIO (IF EQUIPPED)

WHAT IS DIGITAL RADIO

HD Radio™ technology is the digital evolution of analog AM/FM radio.

For additional information, visit www.HDRadio.com.

HD Radio Technology is manufactured under license from iBiquity Digital Corporation and foreign patents. HD Radio and the HD and HD Radio logos are proprietary trademarks of XPERI. The vehicle manufacturer and XPERI are not responsible for the content sent using HD Radio technology. Content may be changed, added or deleted at any time at the station owner's discretion.

HOW DOES DIGITAL RADIO WORK

Your system has a special receiver that allows it to receive digital broadcasts in addition to analog broadcasts.

HD1 signifies the main programming status and is available in both analog and digital broadcasts. Other multicast stations are only available digitally and could contain new or different content.

Note: *When the system first receives an HD1 station, it plays the station in the analog version until it verifies the station is an HD Radio station. Then it shifts to the digital version.*

Note: *There is an audio mute delay when switching to an HD2 or HD3 station because the system has to reacquire and decode the digital signal.*

Audio System

DIGITAL RADIO LIMITATIONS

If you are outside the reception area, the system could not work.

If you are on the fringe of the reception area, the station could mute due to weak signal strength.

Note: *If you are listening to HD1, the system changes back to the analog broadcast until the digital broadcast is available again. If you are listening to any other multicast channels, the station mutes and stays muted unless it is able to connect to the digital signal again.*

Depending on the station quality, you could hear a slight sound change when the station changes between analog and digital audio.

You cannot access a saved HD station if your vehicle is outside the station's reception area.

SWITCHING DIGITAL RADIO RECEPTION ON AND OFF

1. From the apps menu, press AM or FM.
2. Press Settings.
3. Switch HD radio on or off.

DIGITAL RADIO INDICATORS

HD Radio Indicator

The indicator appears when HD Radio is on and you tune to a station broadcasting HD Radio technology.



The color of the indicator changes to indicate the system status.

Gray indicates the system is acquiring a digital station.

Orange indicates digital audio is playing.

Multicast Indicator

The multicast indicator appears if the current station is broadcasting multiple digital broadcasts. The highlighted numbers indicate additional digital channels available.

Note: *For stations that have more than one HD multicast, the HD indicator and radio text appears as a button. Press the button to cycle through all of the HD stations on that specific frequency.*

SATELLITE RADIO (IF EQUIPPED)

WHAT IS SATELLITE RADIO

Your factory-installed SiriusXM radio system includes a limited subscription term, which begins on the date of sale or lease of your vehicle. See an authorized dealer for availability.

For additional information about extended subscription terms, visit www.SiriusXM.com in the United States, www.SiriusXM.ca in Canada, or call SiriusXM at 1-888-539-7474.

Note: *SiriusXM reserves the unrestricted right to change, rearrange, add or delete programming including canceling, moving or adding particular channels, and its prices, at any time, with or without notice to you. Neither SiriusXM and its affiliates nor Ford Motor Company and its affiliates will be liable to you or any third party for any such modification, suspension or termination.*

Audio System

SATELLITE RADIO LIMITATIONS

For optimal reception performance, keep the antenna clear of snow and ice build-up and keep luggage and other material as far away from the antenna as possible. Placing luggage over the antenna may reduce performance. Factory-installed and aftermarket vehicle structures including, but not limited to, roof racks and soft top roofs in a partially open position could reduce reception performance.

Hills, mountains, tall buildings, bridges, tunnels, freeway overpasses, parking garages, dense tree foliage and thunderstorms can interfere with your reception.

When you pass a ground-based broadcast-repeating tower, a stronger signal may overtake a weaker one and could result in the audio system muting. Your display could show an error message to indicate the interference.

LOCATING THE SATELLITE RADIO IDENTIFICATION NUMBER

1. Select SiriusXM as the audio source.
2. Tune to channel 0.

SELECTING A CHANNEL

Manually Selecting a Channel



Press the button to find the previous or next available radio channel.



Linear Tuner

The linear tuner is displayed when manually selecting a channel. You can swipe left or right on the linear tuner carousel to navigate through the channel list. Tap on a channel title to listen to it.

Using Direct Tune

1. Press the channel up or down button to open the linear tuner screen.
2. Press Direct Tune to open the number pad.
3. Enter the channel you prefer.

Using Seek



Press either button.



Using the Channel List

1. Press Browse.
2. Select a channel.

SATELLITE RADIO SETTINGS

Subscription

Your subscription status is displayed. You can subscribe or manage your subscription directly from the touchscreen.

SiriusXM Favorites

While you are listening to SiriusXM, you can save favorites by:

Audio System

- Tapping the currently tuned channel or show logo on the SiriusXM audio screen.
- Tuning to a channel or show you want to save as a favorite. Navigate to the SiriusXM Favorites screen and press the Add Current button. The currently tuned channel or show is saved as a favorite.
- Saving a radio preset. This saves the currently tuned SiriusXM channel or show as a favorite

Note: *Requires a trial or active subscription to use.*

Listening History

Listening history is a list of recently listened to SiriusXM content. You can view, manage and reset the listening history using the controls on the touchscreen.

Note: *Requires a trial or active subscription to use.*

Help and Support

You can contact SiriusXM Customer Care directly from the operating system and view information required to manage your SiriusXM account.

SETTING AN ALERT

Sets a notification for the current song, artist, or sports team. The system alerts you when it plays again on any channel. Selecting this button allows you to enable and edit alerts.

Note: *You can switch alerts on or off and edit them in the satellite radio settings.*

Rear Passenger Audio Controls (If Equipped)

IDENTIFYING THE REAR PASSENGER AUDIO CONTROLS

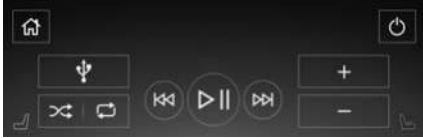

Note: Depending on your vehicle option package, the controls may look different from what you see here.



Press the icon on the touchscreen to access the audio control features.

SWITCHING THE REAR PASSENGER AUDIO CONTROLS ON AND OFF



Press the button on the touchscreen.

SELECTING THE AUDIO SOURCE

Press the Source button to open the media source menu.

You can press the Source button multiple times to change the audio source or scroll through the media sources.

PLAYING AND PAUSING THE AUDIO SOURCE



Press the button to pause playback. Press again to resume playback.

Note: Not all sources can be paused.

ADJUSTING THE VOLUME



Press the buttons on the touchscreen to adjust the volume for the rear passenger audio.



SWITCHING SHUFFLE MODE ON AND OFF



Press the button on the touchscreen to switch shuffle mode on or off.

Note: Not all sources have shuffle mode.

SWITCHING REPEAT MODE ON AND OFF



Press the button on the touchscreen to switch repeat mode on or off.

Note: Not all sources have repeat mode.

CHANGING THE RADIO STATION



In radio mode, select a frequency band and press and release either button. The system stops at the first station it finds in that direction.



Center Display

CENTER DISPLAY OVERVIEW



WARNING: Driving while distracted can result in loss of vehicle control, crash and injury. We strongly recommend that you use extreme caution when using any device that may take your focus off the road. Your primary responsibility is the safe operation of your vehicle. We recommend against the use of any hand-held device while driving and encourage the use of voice-operated systems when possible. Make sure you are aware of all applicable local laws that may affect the use of electronic devices while driving.

For your safety, features that are not critical while driving are not available when the vehicle is moving at or above 5 mph (8 km/h).

Note: Illustrations are provided for conceptual understanding only and may appear differently on your vehicle.

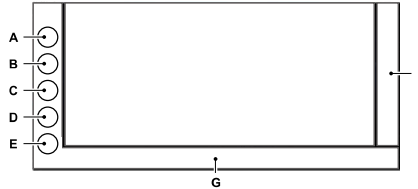

- A Home screen.
- B Controls. See **Controls** (page 470).
- C Apps. See **Apps** (page 470).
- D Instrument panel display. See **Customizing the Instrument Panel Display** (page 470).
- E Android Auto or Apple CarPlay. See **Switching Android Auto™ On and Off** (page 478). See **Switching Apple CarPlay On and Off** (page 478).
- F Status bar. See **Status Bar** (page 469).
- G Climate control. See **Climate Control** (page 129).



If you see this icon, press it for more information.



If you see this icon, press it to open the settings menu for the app or feature.



If you see this icon, press it to search within that app or feature.

STATUS BAR

The following icons can appear in the status bar.

Notification Center



Press to view notifications.



Unread notifications available. Press to view notifications.

Device Signal



Device signal strength.



Device signal roaming.



Device signal not available.

Center Display

Vehicle Signal



Data unavailable or disabled.



Wi-Fi connected.



Wi-Fi not connected.



Wi-Fi connected, internet unavailable.



Vehicle signal strength.



Vehicle signal roaming.



Vehicle signal not available.

Privacy



Vehicle location sharing on.



Microphone active.

APPS



Press to see a list of apps. To open an app, select the app.

You can download additional apps on your vehicle through Google Play. To download additional apps, make sure your vehicle is in park (P), connected to the internet and signed in to an active personal Google Account.

When you start an app through the system for the first time, you could be asked to grant certain permissions. You can review and change the permissions at any time when your vehicle is not moving. We recommend that you check the app provider's terms and conditions and privacy policy before using their app. Make sure that you have an active account for apps that you want to use through the system. Some apps work with no setup. Others require you to configure personal settings and enable data connectivity before you can use them.

Customizing the Apps Screen

1. Press and hold an app.
2. Drag the app to a new location.

CONTROLS



Press to open the controls screen where you can turn common features off and on.

Customizing the Controls Screen

1. Press and hold a control tile.
2. Drag the control tile to a new location.

CUSTOMIZING THE INSTRUMENT PANEL DISPLAY



Press to change the layout for the instrument panel display screen.



If you see this icon on an item, press it to see more actions for that item.

Center Display

Adding, Removing, or Reordering Items

- To add an item to the instrument panel display screen, drag it into one of the spots at the top of the screen.
- To remove an item, drag it down from the spot at the top of the screen.
- To reorder items, drag an item from one spot to another.

Switching On the Calm Screen

The calm screen changes the instrument panel display screen to a simplified view.

1. At the top of the screen, turn on the Calm switch.

SETTINGS



From the apps menu, press to open the settings app.

You can change the display language and other measurement units under the System menu.



If you see this icon next to a menu option, press it for more information.



If you see this icon in the top corner, press it to open the settings for that app or feature.

Display Settings

From the display menu you can do the following:

- Switch the calm screen on.
- Manually adjust the screen brightness.
- Set the display mode.

Touchscreen Brightness

To manually adjust the screen brightness, use the plus or minus buttons.

Note: *The display brightness is limited if the settings of the instrument panel lighting brightness are set to the highest or lowest setting.*

REBOOTING THE DISPLAYS

If the center display or instrument cluster screens go blank or appear to not be functioning correctly, you can reboot it by following the below procedure.

Press and hold the audio system power button for 10 seconds.

Contact an authorized dealer if the screens do not reboot properly.

Voice Interaction

WHAT IS VOICE INTERACTION

Voice Interaction allows you to control vehicle features using conversational requests.

SETTING YOUR DEFAULT ASSISTANT

You can set your default assistant to Google Assistant or Alexa Built-In.

1. From the settings menu, press Assistant & voice.
2. Press Digital assistant app.
3. Select the digital assistant you prefer.

ALEXA BUILT-IN

Alexa Built-In allows you to use Alexa in your vehicle for auto-specific use cases on the road and gives you access to an ever-evolving number of skills that help to make your life more productive, entertaining, and connected while using your vehicle.

Alexa Built-In Requirements

To use Alexa, all of the following must occur:

- Your vehicle modem is enabled.
- You are signed in to an existing Amazon account.
- Vehicle connectivity and vehicle data sharing is enabled.

Note: Support and functionality may vary based on the country in which your Ford mobile app account is registered.

Signing In to Your Account

1. Open the app menu.

2.



Press the button and follow the on-screen prompts to sign in to your account.

Note: You can also sign in to Alexa via the settings menu.

Signing Out of Your Account

1.



From the Alexa screen, press the button.

2. Press **Sign Out**.

Using Alexa Built-In

Alexa can be used in three ways:

1. Say Alexa.

Note: Alexa must be set as your default assistant and the wake word must be enabled.

2.



Press the voice interaction button on the steering wheel and then say Alexa to invoke Alexa to start listening.

Note: Alexa must be set as your default assistant.

3.



From the Alexa app screen, press the button.

You can use Alexa for the following and more:

- Entertainment.
- Hands-free calling.
- Traffic and navigation.
- Vehicle controls.
- Smart home device control.
- Weather and news information.

Voice Interaction

You can adjust the following settings in the touchscreen:

- Enable or disable the wake word.
- Enable or disable contact list sharing for connected phones.
- Learn more about what you can do with Alexa by browsing the things to try.
- Set the default assistant setting.

GOOGLE ASSISTANT

Google Assistant allows you to use your voice to perform everyday tasks. You can make calls, get directions, play music, and control certain functions of your vehicle.

Google, Android, Android Auto, Google Maps word mark and logos are registered trademarks owned by Google LLC.

Signing In to Your Account

Signing in to Google Assistant can be done in a number of ways, but the setup wizard on first boot is the most convenient way.

1. From the settings menu, press Driver profile settings.
2. Press Accounts.
3. Press Add.

4. Select Google Account under associate accounts.

Note: You can use Google Assistant without signing into a Google Account, but signing in unlocks greater functionality such as smart home functionality and productivity features.

Signing Out of Your Account

1. From the settings menu, press Driver profile settings.
2. Press Accounts.
3. Press Remove.
4. Select Google Account under associate accounts.

Using Google Assistant

Google Assistant can be used in three ways:

1. Say Hey Google.

Note: Google Assistant must be set as your default assistant and the wake word must be enabled.

2.  Press the voice interaction button on the steering wheel and then say Hey Google to invoke Google Assistant to start listening.

Note: Press the voice interaction button again to interrupt a voice prompt and begin speaking.

Note: Google Assistant must be set as your default assistant.

3.  From the app menu, press the Google Assistant button.

You can use Google Assistant for the following and more:

- Entertainment.
- Hands-free calling.
- Traffic and navigation.
- Vehicle controls.
- Managing your schedule.
- Looking up answers.
- Smart home device control.
- Weather and news information.

You can adjust the following settings in the touchscreen:

- Adjust the language of your voice assistant.
- Enable or disable the wake word.
- Allow personal results in this car.
- Allow suggestions from your voice assistant.

Voice Interaction

- Get notifications from your voice assistant.
- Read and respond to vehicle notifications.

For additional information and settings about Google Assistant, scan the code.



Phone

PHONE PRECAUTIONS



WARNING: Driving while distracted can result in loss of vehicle control, crash and injury. We strongly recommend that you use extreme caution when using any device that may take your focus off the road. Your primary responsibility is the safe operation of your vehicle. We recommend against the use of any hand-held device while driving and encourage the use of voice-operated systems when possible. Make sure you are aware of all applicable local laws that may affect the use of electronic devices while driving.

CONNECTING YOUR PHONE

1. From the settings menu, press Bluetooth.
2. Press Add device.

Note: A prompt alerts you to search for your vehicle on your cell phone.

3. Select your vehicle on your cell phone.

Note: A number appears on your cell phone and on the touchscreen.

4. Confirm the number on your cell phone matches the number on the touchscreen.

Note: The touchscreen indicates that you have successfully paired your cell phone.

5. Approve phonebook download request on your cell phone.

PHONE MENU

This menu becomes available after pairing a phone.

Recent Call List

Display and select an entry from a list of previous calls.

Contacts

Displays a smart search form to look up your contacts. Use the List button to alphabetically sort your contacts.

Favorites

Displays the list of favorite contacts that are set up on your phone.

SMS app

Displays the list of text messages to read, listen to, or respond to.

Phone List

Displays the list of paired or connected devices that you can select.

Note: Up to 12 devices can be stored.

Do Not Disturb

Reject incoming calls and switch ring tones and alerts off.

Phone Keypad

Directly dial a number.

Voice Control

Press the button and say a command to use the Google Assistant or Siri voice assistant available on your connected phone to access supported features.

Note: Some features under the phone menu may not be available if the feature is not supported through the phone.

Phone

MAKING AND RECEIVING A PHONE CALL

Making Calls

To call a number in your contacts, select:

Menu Item	Action and Description
Contacts	Select the name of the contact you want to call. Any numbers stored for that contact display along with any stored contact photos. Select the number that you want to call. The system begins the call.

To call a number from your recent calls, select:

Menu Item	Action and Description
Recent Call List	Select an entry that you want to call. The system begins the call.

To call a number from your favorites, select:

Menu Item	Action and Description
-----------	------------------------

Menu Item	Action and Description
Favorites	Select an entry that you want to call. The system begins the call.

To call a number that is not stored in your phone, select:

Menu Item	Action and Description
Phone Keypad	Select the digits of the number you wish to call.
Call	The system begins the call.

Pressing the backspace button deletes the last digit you typed.

Receiving Calls

During an incoming call, an audible tone sounds. Caller information appears in the display if it is available.

To accept the call, select:

Menu Item
Accept

Note: You can also accept the call by pressing the phone button on the steering wheel.

To reject the call, select:

Menu Item
Reject

Ignore the call by doing nothing. The system logs it as a missed call.

During a Phone Call

During a phone call, the contacts name and number display on the screen along with the call duration.

The phone status items are also visible:

- Signal Strength.
- Battery.

You can select any of the following during an active phone call:

Phone

Item	
End Call	Immediately end a phone call. You can also press the button on the steering wheel.
Keypad	Press this to access the phone keypad.
Mute	You can switch the microphone off so the caller does not

Item	
	hear you.
Privacy	Transfer the phone call audio to the cell phone or back to the touchscreen.
Hold	This feature allows you to put the active call on hold, to either make another call or answer an incoming call.

SENDING AND RECEIVING A TEXT MESSAGE

Menu Item	Description
Hear It	Hear the text message.
View	View the text message.
Call	Call the sender.
Reply	Reply to the text message with a standard text message.

Phone

SWITCHING TEXT MESSAGE NOTIFICATION ON AND OFF

The settings on your device must be enabled to receive text message notifications on the center display. Check your device settings to enable these features.

SWITCHING APPLE CARPLAY ON AND OFF

The operating system is compatible with wireless Apple CarPlay on iPhone 6s or later. Make sure your iPhone has been updated to the latest version of iOS.

Enabling Wireless Apple CarPlay

1. Pair your device to **Bluetooth**. See **Connecting Your Phone** (page 475).
2. Follow the instructions on your device and the touchscreen.

Disabling Wireless Apple CarPlay

While Apple CarPlay is connected:

1. From the settings menu, press Bluetooth.
2. Find your device in the list.
3. Press the Apple CarPlay button.

Re-Enabling Wireless Apple CarPlay

1. From the settings menu, press Bluetooth.
2. Select your device from the list.
3. Press the Apple CarPlay button.

SWITCHING ANDROID AUTO™ ON AND OFF

Enabling Android Auto with USB (if Equipped)

1. Connect your device to a USB port.
2. Follow the instructions on your device and the touchscreen.

Enabling Android Auto with Wireless

1. Pair your device to **Bluetooth**®.
2. Follow the instructions on your device and the touchscreen.

Note: A compatible Android phone and active data plan are required to use Android Auto.

Note: Android Auto Wireless is not supported on certain **Android™** devices.

For more information, scan here.



Disabling Android Auto

While Android Auto is connected:

1. From the settings menu, press Bluetooth.
2. Find your device in the list.
3. Press the Android Auto button.

Re-Enabling Android Auto

1. From the settings menu, press Bluetooth.
2. Find your device in the list.
3. Press the Android Auto button.

Note: While using Android Auto/Apple CarPlay, some vehicle data such as speed and location is shared with your phone. This data does not identify you. Vehicle manufacturer is not responsible for the way this data is handled and may disable Android Auto/Apple CarPlay at any time.

Bluetooth®

CONNECTING A BLUETOOTH® DEVICE

1. From the settings menu, press Connectivity.
2. Press Phone list.
3. Press Bluetooth.

Note: A prompt alerts you to search for your vehicle on your device.

1. Select your vehicle on your device.

Note: A number appears on your device and on the touchscreen.

2. Confirm that the number on your device matches the number on the touchscreen.

Note: The touchscreen indicates that you have successfully paired your device.

The **Bluetooth®** word mark and logos are registered trademarks owned by **Bluetooth SIG, Inc.** and any use of such marks by Ford Motor Company is under license. Other trademarks and trade names are those of their respective owners.

PLAYING MEDIA USING BLUETOOTH®



WARNING: Driving while distracted can result in loss of vehicle control, crash and injury. We strongly recommend that you use extreme caution when using any device that may take your focus off the road. Your primary responsibility is the safe operation of your vehicle. We recommend against the use of any hand-held device while driving and encourage the use of voice-operated systems when possible. Make sure you are aware of all applicable local laws that may affect the use of electronic devices while driving.

Connect your device.

From the Apps menu, press Bluetooth audio.



Press to play a track. Press again to pause the track.



Press to skip to the next track.
Press and hold to fast forward through the track.



Press once to return to the beginning of a track. Repeatedly press to return to previous tracks.

Press and hold to fast rewind through the track.

Personal Profiles

HOW DO PERSONAL PROFILES WORK

This feature allows you to create multiple personal profiles enabling users to personalize the vehicle's settings such as seats and mirrors, as well as non-positional settings like radio, navigation and driver assist. Non-positional settings are saved when you change a setting while a profile is active.

ENABLING OR DISABLING PERSONAL PROFILES

The vehicle does not allow the user to disable personal profiles.

Note: *Personal profiles are disabled automatically when Valet Mode is entered.*

CREATING A PERSONAL PROFILE

1. Switch the vehicle on and leave it in park (P).
2. From the settings menu, press Profile.
3. Follow the instructions on the display.

Note: *The guest profile is auto created with its own memory settings.*

Note: *You cannot link a personalized name to a guest profile.*

USING THE MEMORY FUNCTION

(IF EQUIPPED)

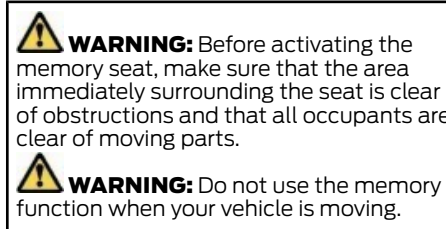

The driver memory function recalls the following positions:

- Memory driver seat.
- Memory mirrors.
- Memory steering column.
- Memory adjustable foot pedals.

Saving and recalling a preset position

The driver memory function allows you to save and recall the desired position of a profile.

You can only recall a position by choosing that profile in the profile menu.

You can recall the profile along with its saved position when the vehicle is in park (P) or neutral (N) and the vehicle is not moving.

Note: *Pressing any position control switches during a memory position recall cancels a recall.*

Auto Save option

Auto Save detects any memory position adjustments and saves them to the current profile.

Auto Save allows you to automatically save memory positions for the driver seat, exterior mirrors, steering column and adjustable foot pedals.

Personal Profiles

LINKING OR UNLINKING A PERSONAL PROFILE TO A REMOTE CONTROL

You can save a personal profile, including saved memory positions, for up to three remote controls by assigning a remote control to a profile using the touchscreen.

1. From the settings menu, press Profile.
2. Press Edit.
3. Press ID methods.
4. Press Key fob label.
5. Follow the onscreen instructions to link or unlink a remote control.

Note: *If more than one linked remote control is in range, the memory function moves to the settings of the first key to initiate a memory recall.*

Note: *Each remote can be linked to only one personal profile.*

Note: *You cannot link a remote control to a guest profile.*

LINKING OR UNLINKING A PERSONAL PROFILE TO A DEVICE

You can save a profile, including saved memory positions, for up to three devices by assigning a device to a personal profile using the touchscreen.

1. From the settings menu, press Profile.
2. Press Edit.
3. Press ID methods.
4. Press Phone as a key label.
5. Follow the onscreen instructions to link or unlink a device.

Note: *Each device can be linked to only one personal profile.*

Note: *You cannot link a device to a guest profile.*

Note: *You cannot link a personalized name to a guest profile.*

Locking a personal profile

Profile lock allows you to lock your profile and prevent others from accessing the profile.

1. From the settings menu, press Profile.

2. Press Profile settings.
3. Press Security.
4. Press Profile lock.
5. Press to choose your preferable lock type.
6. Follow the onscreen instructions to create a profile lock.

Note: *If all user profiles are passcode protected, and the passcodes are unknown, take your vehicle to an authorized dealer to reset the system.*

Navigation

CONNECTED NAVIGATION

Google Maps provides the navigation software on your vehicle. For more information scan here:



Vehicle Software Updates

Ford Power-Up software updates uses over-the-air technology to deliver the latest features, software enhancements and quality improvements to your vehicle.

When Automatic Updates is turned on updates are downloaded in the background while you are driving.

Some updates require your vehicle to be parked. You can set a recurring schedule when your vehicle is not in use (like overnight). Scheduled updates usually take up to 45 minutes and some updates can take longer than that. Check your center display screen or the Ford Pass app for the most accurate estimated update time.

Software updates are delivered wirelessly using the vehicle modem or Wi-Fi. To make sure of the most seamless experience See **Connecting the Vehicle to a Wi-Fi Network** (page 458).

Software Update Requirements

The following conditions must be met to receive scheduled updates:

- The vehicle is parked.
- The ignition is off.
- All doors are closed.
- Your foot is off the brake pedal.

- The parking lamps are off.
- The alarm is not triggered.
- The hazard indicators are off.
- Your 12V battery is charged.
- No emergency calls are in place.
- Your vehicle is not in limp home mode.

Software Update Limitations

Once a scheduled update begins you cannot:

- Cancel the update.
- Drive your vehicle.
- Start the ignition.
- Start your vehicle.
- Use the alarm, central locks or door tones.
- Use the remote control to lock, unlock or start your vehicle.
- Use the electronic door locks.
- Fast charge your electric vehicle.
 - If connected to a level 1 or 2 charger, charging pauses until the update is completed.

Note: *If an update is interrupted you will receive a notification on Ford Pass app with instructions to resolve it. If there are no action steps, contact your authorized dealer.*

SOFTWARE UPDATE SETTINGS

To access the Software Updates menu:

1. Press Settings on the touchscreen.
2. Press System.
3. Press Software Updates.

You can do the following in the Software Updates menu:

- Switch Automatic Updates on and off.
- Schedule and install software updates.
- View software update details.



Press the button next to a menu option for more information.

Switching Automatic Updates On and Off

Your vehicle may come with Automatic Updates switched on. To make sure your vehicle always has the latest software, which could include security or other enhancements, we do not recommend switching Automatic Updates off.

Note: *Software updates require approval to download or install with Automatic Updates switched off.*

Vehicle Software Updates

Scheduling and Installing Software Updates

Scheduling Software Updates

From the Software Updates menu:

1. Press **Schedule Updates**.
2. Select the days and time for updates.

The more days that updates are scheduled, the more frequently your vehicle installs new updates. We recommend selecting a time you normally do not need your vehicle, such as overnight.

Some updates require your vehicle to be switched off.

Note: *The schedule you set is recurring. If Automatic Updates is on, every time a scheduled update is available, it installs on this schedule unless you change it. You are notified on your touchscreen and connected device prior to a scheduled update, with an option to reschedule it.*

Installing Software Updates

Using the Notification Center

1. Press a Software Update indicator on your touchscreen when it appears.

2. Follow the instructions on the touchscreen.

Using the Touchscreen

From the Software Updates menu:

1. Press Update Details.
2. Press Update Now.

Viewing Software Update Details

From the Software Updates menu, press Update Details.

SOFTWARE UPDATE INDICATORS



Vehicle software update reminder, schedule required, confirmation of default schedule required, or consent required.



Vehicle software update canceled, update not successful, or precondition not met.



Vehicle software update successful.

Vehicle System Reset

PERFORMING A SYSTEM RESET

To perform a reset:

1. Press Settings from the Apps menu.
2. Press System.
3. Press Reset options.
4. Select the reset you prefer.
5. Follow the prompts on screen to complete the reset.



There are multiple resets available, press the button next to each for more information.

Perform a factory reset whenever there is a transfer of vehicle ownership to prevent the loss of personal data. Performing a factory reset allows you to remove all personal information and restore the modem and center display to their factory defaults.

In the modem, this deletes all the authorized users and removes access to the connected vehicle. In the system this deletes all data imported from mobile devices connected to the vehicle via **Bluetooth**® including the addresses manually entered into the navigation system.

Note: *If you are the first owner, your modem comes in a partially activated state.*

Note: *If you are not the first owner, it comes in either a fully activated, partially activated or deactivated state.*

Accessories

For a complete listing of the accessories that are available for your vehicle, please contact your authorized dealer or visit the online store website:

Web Address (United States)
https://accessories.lincoln.com/

Web Address (Canada)
www.lincolncanada.com

We will repair or replace any properly authorized dealer-installed Lincoln Original Accessory found to be defective in factory-supplied materials or workmanship during the warranty period, as well as any component damaged by the defective accessories.

We will warrant your Lincoln Original Accessory through the warranty that provides the greatest benefit:

- 24 months, unlimited mileage.
- The remainder of your new vehicle limited warranty.

Lincoln Licensed Accessories

The accessory manufacturer designs, develops and therefore warrants Lincoln Licensed Accessories, and does not design or test these accessories to Lincoln engineering requirements. Contact an authorized Lincoln dealer for the accessory manufacturer's limited warranty details and request a copy of the Lincoln Licensed Accessories product limited warranty from the accessory manufacturer. See your warranty guide for more information.

For maximum vehicle performance, keep the following information in mind when adding accessories or equipment to your vehicle:

- When adding accessories, equipment, passengers and luggage to your vehicle, do not exceed the total weight capacity of the vehicle or of the front or rear axle (GVWR or GAWR as indicated on the Safety Compliance Certification label). Ask an authorized dealer for specific weight information.
- The Federal Communications Commission (FCC) and Canadian Radio Telecommunications Commission (CRTC) regulate the use of mobile communications systems that have radio transmitters, for example two-way radios, telephones and theft alarms. Any such equipment installed in your vehicle should comply with Federal Communications Commission (FCC) and Canadian Radio Telecommunications Commission (CRTC) regulations and should only be installed by an authorized dealer.

Accessories

- Mobile communications systems may harm the operation of your vehicle, particularly if their manufacturer did not design them specifically for automotive use.
- If you or an authorized Lincoln dealer add any non-Lincoln electrical or electronic accessories or components to your vehicle, you may adversely affect battery performance and durability. In addition, you may also adversely affect the performance of other electrical systems in the vehicle.

Ford Protect

WHAT IS FORD PROTECT

Ford Protect vehicle service contracts are the only service contracts 100% backed by Ford Motor Company. Protect yourself from unforeseen covered repairs with a Ford Protect extended service plan.

Ford Protect Extended Service Plans - United States Only

You can drive on with confidence as Ford Protect extended service plans provide more protection beyond the New Vehicle Limited Warranty. When you visit your Ford Dealer, insist on a Ford Protect extended service plan.

Ford Protect Can Quickly Pay for Itself

One repair bill can easily exceed the price of your Ford Protect extended service plan. With the Ford Protect extended service plan, you have peace of mind from unforeseen covered repairs.

Up to 1,000+ Covered Vehicle Components

There are four mechanical Ford Protect extended service plans with different levels of coverage to fit your individual needs. Ask your Ford dealer for details.

1. PremiumCARE - Our most comprehensive coverage. With over 1,000 covered components, this plan is so complete it is probably easier to list what is not covered.
2. ExtraCARE - Covers 113 components, and includes many high-tech items.
3. BaseCARE - Covers 84 components.
4. PowertrainCARE - Covers 29 critical components.

Ford Protect extended service plans are honored by all authorized Ford dealers in the United States, Canada and Mexico.

That means you get:

- Ford-authorized parts used for covered repairs.
- Factory-trained and certified technicians.
- Rental vehicle benefits for up to 10 days for covered repairs.

24-Hour Roadside Assistance

Roadside assistance includes:

- Tire change, lockout, out-of-fuel and battery jump-start assistance.
- Towing Assistance.
- Emergency Travel Expense.
- Destination Assistance.

Transferable Coverage

If you sell your vehicle before your Ford Protect extended service plan coverage expires, you can transfer any remaining coverage to the new owner.

Premium Maintenance Plan

It is more than just a routine oil change. Keep your vehicle running at its optimum performance with a Ford Protect Premium Maintenance extended service plan. The coverage is prepaid, so you never have to worry about the future cost of your vehicle's maintenance.

Premium Maintenance covers these important maintenance items:

- Engine oil and filter changes.
- Multi-point inspections.
- Tire rotations.
- Brake pads and linings.
- Shock absorbers and struts.
- Spark plugs.
- Clutch discs-if equipped.
- Engine belts, coolant hoses and clamps.
- Wiper blades.

Ford Protect

More Information

To learn more about Ford Protect plans and financing options, please contact your selling Ford Dealer.

Ford Protect Extended Service Plan - Canada Only

You can get more protection for your vehicle by purchasing a Ford Protect extended service plan. Ford Protect extended service plan is the only service contract backed by Ford Motor Company of Canada, Limited. Depending on the plan you purchase, Ford Protect extended service plan provides benefits such as:

- Rental reimbursement.
- Coverage for certain maintenance and wear items.
- Protection against repair costs after your New Vehicle Limited Warranty Coverage expires.
- Roadside Assistance benefits.

There are several Ford Protect extended service plans available in various time, distance and deductible combinations. Each plan is tailored to fit your own driving needs, including reimbursement for towing and rental. When you purchase a Ford Protect extended service plan, you receive added peace-of-mind protection throughout Canada, the United States and Mexico, provided by a network of participating authorized Ford Motor Company dealers.

Note: *Repairs performed outside of Canada and the United States are not eligible for Ford Protect extended service plan coverage.*

This information is subject to change. Visit your local Ford of Canada dealer or www.ford.ca to find the Ford Protect extended service plan that is right for you.

Scheduled Maintenance

Intelligent Oil-Life Monitor™

Your vehicle has an Intelligent Oil-Life Monitor that determines when you should change the engine oil based on how you use your vehicle. By using several important factors in its calculations, the monitor helps reduce the cost of owning your vehicle and

reduces environmental waste at the same time.

This means you do not have to remember to change the oil on a mileage-based schedule. Your vehicle lets you know when an oil change is due by displaying a message in the instrument cluster display.

The following table provides examples of vehicle use and its impact on oil change intervals. It is a guideline only. Actual oil change intervals depend on several factors and generally decrease with severity of use.

Maintenance Intervals

At Every Oil Change Interval as Indicated by the Information Display ¹
Change the engine oil and filter. ²
Rotate the tires, inspect tire wear and measure tread depth.
Perform a multi-point inspection - recommended.
Inspect the automatic transmission fluid level - vehicles with dipstick. Consult your dealer for requirements.
Inspect the brake pads, rotors, hoses and parking brake.
Inspect the engine cooling system strength and hoses.
Inspect the exhaust system and heat shields.
Inspect the front axle and U-joints.
Inspect the half-shaft boots.
Inspect the steering linkage, ball joints, suspension, tire-rod ends, driveshaft and U-joints.
Inspect the wheels and related components for abnormal noise, wear, looseness or drag.

Scheduled Maintenance

At Every Oil Change Interval as Indicated by the Information Display ¹
Inspect cabin air filter if equipped, service as required.
Inspect engine air filter, service as required.

¹ Do not exceed one year or 10,000 mi (16,000 km) between service intervals.

² Reset the Intelligent Oil-Life Monitor after engine oil and filter changes. See **Resetting the Intelligent Oil Life Monitor** (page 399).

Brake Fluid Maintenance ¹	
Every three years.	Change the brake fluid. ²

¹ Perform this maintenance item every three years. Do not exceed the designated time for the interval.

² Brake fluid servicing requires special equipment available at your authorized dealer.

Other Maintenance Items ¹	
Every 20,000 mi (32,000 km)	Replace the cabin air filter.
Every 30,000 mi (48,000 km)	Replace the engine air filter.
Every 60,000 mi (96,000 km)	For severe service, replace the spark plugs. For severe service, change the transfer case fluid.
Every 100,000 mi (160,000 km)	Replace the spark plugs.
	Inspect the accessory drive belt(s). ²

Scheduled Maintenance

Other Maintenance Items ¹	
Every 150,000 mi (240,000 km)	Change the automatic transmission fluid.
	Change the front axle fluid - Four-wheel drive vehicles.
	Change the rear axle fluid.
	Change the transfer case fluid - Four-wheel drive vehicles.
	Replace the accessory drive belt(s).
Every 200,000 mi (320,000 km)	Change the engine coolant. ³

¹ Perform these maintenance items within 5,000 mi (8,000 km) of the last engine oil and filter change. Do not exceed the designated distance for the interval.

² After initial inspection, inspect every other oil change until replaced.

³ Initial replacement at 10 years or 200,000 mi (320,000 km), then every 5 years or 100,000 mi (160,000 km).

Exceptions

There are several exceptions to the schedule:

Axle and Transfer Case Maintenance

The transfer case, front and rear axles in your vehicle do not require scheduled maintenance. They are more likely to require a fluid change if the vehicle has experienced extended periods of extreme or severe duty cycle driving. Changing or checking the transfer case, front and/or rear axle lubricant is not necessary unless the unit has been submerged in water, shows signs of leakage. Contact your authorized dealer for service.

California Fuel Filter Replacement

If you register your vehicle in California, the California Air Resources Board has determined that the failure to perform this maintenance item does not nullify the emission warranty or limit recall liability before the completion of your vehicle's useful life. Ford Motor Company, however, urges you to have all recommended maintenance services performed at the specified intervals and to record all vehicle service.

Scheduled Maintenance

Hot Climate Oil Change Intervals

Vehicles operating in the Middle East, North Africa, Sub-Saharan Africa or locations with similar climates using an American Petroleum Institute (API) Certified for Gasoline Engines (Certification mark) oil of SM or SN quality, the oil change interval is 3,000 mi (5,000 km). If the available API SM or SN oils are not available, then the oil change interval is 2,000 mi (3,200 km)

Engine Air Filter and Cabin Air Filter Replacement

The life of the engine air filter and cabin air filter is dependent on exposure to dusty and dirty conditions. Vehicles operated in these conditions require frequent inspection and replacement of the engine air filter and cabin air filter.

What Are Considered Severe Driving Conditions

A vehicle that is driven for short trips of less than 5–10 mi (8–16 km), driving in temperatures well below or above average, driving in any dusty conditions, idling more than recommended such as in traffic, and driving with a heavy load or while towing a load are considered severe driving conditions. If the vehicle is driven in any of these conditions, follow the severe service maintenance items listed in the scheduled maintenance chart.

GENERAL MAINTENANCE INFORMATION

Why Maintain Your Vehicle?

Carefully following the maintenance schedule helps protect against major repair expenses resulting from neglect or inadequate maintenance and may help to increase the value of your vehicle when you sell or trade it. Keep all receipts for completed maintenance with your vehicle.

It is important that you have your vehicle serviced at the proper times. These intervals serve two purposes: first is to maintain the reliability of your vehicle and the second is to keep the cost of owning your vehicle down.

It is your responsibility to have all scheduled maintenance performed and to make sure that the materials used meet the specifications identified in this owner's manual.

Failure to perform scheduled maintenance and regularly inspect your vehicle may result in vehicle damage not covered by the vehicle Warranty.

Why Maintain Your Vehicle at Your Dealership?

Our Genuine Replacement Parts

Dealerships stock our parts and our authorized branded remanufactured replacement parts. These parts meet or exceed our specifications. Parts installed at your dealership carry a nationwide 24-month or unlimited mile (kilometer) parts and labor limited warranty.

If you do not use our authorized parts, they may not meet our specifications and could affect emissions compliance.

Scheduled Maintenance

Protecting Your Investment

Maintenance is an investment that pays dividends in the form of improved reliability, durability and resale value. To maintain the proper performance of your vehicle and its emission control systems, make sure you have scheduled maintenance performed at the designated intervals.

Your vehicle comes with the Intelligent Oil-Life Monitor system, a message appears in the instrument cluster display at the proper oil change interval. This interval may be up to one year or 10,000 mi (16,000 km), hybrid vehicles could exceed 10,000 mi (16,000 km).

When the oil change message appears in the instrument cluster display, it is time for an oil change. Make sure you perform the oil change within two weeks or 500 mi (800 km) of the message appearing. Make sure to reset the Intelligent Oil-Life Monitor after each oil change. See **Resetting the Intelligent Oil Life Monitor** (page 399).

If your instrument cluster display resets prematurely or becomes inoperative, you should perform the oil change interval at six months or 5,000 mi (8,000 km) from your last oil change. Never exceed one year or 10,000 mi (16,000 km) between oil change intervals.

You can drive your vehicle in such a way that may lead to higher oil consumption including extended time at high engine speeds, high loads, engine braking, hard cornering maneuvers, track and off-road usage. Under these conditions, oil consumption of approximately 1 quart per 500 miles (1 liter per 800 km) is possible. Check the engine oil level at every refueling and adjust to maintain proper levels to avoid engine damage.

You can also drive your vehicle in such a way that dilutes and increases the level of oil by frequent short trips that do not allow the engine to get to operating temperature, extended idling and low speed driving for long periods of time.

It is important to rely upon your dealership to properly diagnose and repair your vehicle.

We strongly recommend only using our genuine or our authorized re-manufactured replacement parts engineered for your vehicle.

Additives and Chemicals

We do not recommend using chemicals or additives not approved by us as part of your vehicle's normal maintenance. Please consult your warranty information.

Oils, Fluids and Flushing

In many cases, fluid discoloration is a normal operating characteristic and, by itself, does not necessarily indicate a concern or that the fluid needs to be changed. Have discolored fluids that also show signs of overheating or foreign material contamination checked immediately.

Make sure to change the vehicle's oils and fluids at the specified intervals or in conjunction with a repair. Flushing is a viable way to change fluid for many vehicle sub-systems during scheduled maintenance. It is critical that systems are flushed only with new fluid that is the same as that required to fill and operate the system or using our approved flushing chemical.

Scheduled Maintenance Service Intervals

For your scheduled maintenance service intervals, visit <https://www.ford.com/support/maintenance-schedule>.

Owner Checks and Services

Make sure you perform the following basic maintenance checks and inspections.

Scheduled Maintenance

Check Every Month
The engine oil level.
Function of all interior and the exterior lights.
The tires including the spare for wear and proper pressure.
The windshield washer fluid level.

Check Every Six Months
The battery connections. Clean if necessary.
The body and door drain holes for obstructions. Clean if necessary.
The cooling system fluid level and the coolant system strength.
The door weatherstrips for wear. Lubricate if necessary.
The hinges, latches and outside locks for proper operation. Lubricate if necessary.
The parking brake for proper operation.
The seatbelts and seat latches for wear and function.
Safety warning lamps, brake, ABS, airbag and seatbelt for operation.
The washer spray and wiper operation. Clean or replace blades as necessary.

Scheduled Maintenance

Multi-Point Inspection

It is important to have the systems on your vehicle regularly checked. This can help identify potential issues and prevent major

problems. We recommend having the following multi-point inspection performed at every scheduled maintenance interval to help make sure your vehicle keeps running great.

Multi-Point Inspection	
Accessory drive belt or belts	Hazard warning system operation
Battery performance	Horn operation
Engine air filter	Radiator, cooler, heater and air conditioning hoses
Exhaust system	Suspension components for leaks or damage
Exterior lamps operation	Steering and linkage
Fluid levels ¹ ; fill if necessary	Tires including the spare for wear and proper pressure ²
For oil and fluid leaks	Windshield for cracks, chips or pits
Halfshaft dust boots	Washer spray and wiper operation

¹ Brake, coolant recovery reservoir, automatic transmission and window washer.

² If your vehicle has a temporary mobility kit, check the tire sealant expiration Use By date on the canister. Replace as needed.

Scheduled Maintenance

Be sure to ask your dealership service advisor or technician about the multi-point vehicle inspection. It is a comprehensive way to perform a thorough inspection of your vehicle. Your checklist gives you immediate feedback on the overall condition of your vehicle.

Severe Driving Conditions

A vehicle that is driven for short trips of less than 5–10 mi (8–16 km) miles, driving in temperatures greatly below or above average, driving in any dusty conditions, idling more than recommended such as in traffic, and driving with a heavy load or while towing a load are considered severe driving conditions. If you drive your vehicle in any of these conditions, follow the severe service maintenance items listed in the scheduled maintenance chart.

Customer Information

ROLLOVER WARNING



WARNING: Utility vehicles have a significantly higher rollover rate than other types of vehicles.



WARNING: Vehicles with a higher center of gravity (utility and four-wheel drive vehicles) handle differently than vehicles with a lower center of gravity (passenger cars). Avoid sharp turns, excessive speed and abrupt steering in these vehicles. Failure to drive cautiously increases the risk of losing control of your vehicle, vehicle rollover, personal injury and death.



WARNING: In a rollover crash, an unbelted person is significantly more likely to die than a person wearing a seatbelt.



WARNING: Do not become overconfident in the ability of four-wheel drive vehicles. Although a four-wheel drive vehicle may accelerate better than a two-wheel drive vehicle in low traction situations, it won't stop any faster than two-wheel drive vehicles. Always drive at a safe speed.

Utility vehicles and trucks handle differently than passenger cars in the various driving conditions that are encountered on streets, highways and off-road. Utility vehicles and trucks are not designed for cornering at speeds as high as passenger cars any more than low-slung sports cars are designed to perform satisfactorily under off-road conditions.

THE BETTER BUSINESS BUREAU AUTO LINE PROGRAM - UNITED STATES OF AMERICA

Your satisfaction is important to Ford Motor Company and to your dealer. If a warranty concern has not been resolved using the three-step procedure outlined earlier in this chapter in the Getting the Services you need section, you may be eligible to participate in the BBB AUTO LINE program.

The BBB AUTO LINE program consists of two parts – mediation and arbitration. During mediation, a representative of the BBB will contact both you and Ford Motor Company to explore options for settlement of the claim. If an agreement is not reached during mediation or you do not want to participate in mediation, and if your claim is eligible, you

may participate in the arbitration process. An arbitration hearing will be scheduled so that you can present your case in an informal setting before an impartial person. The arbitrator considers the testimony provided and makes a decision after the hearing.

Disputes submitted to the BBB AUTO LINE program are usually decided within 40 days after you file your claim with the BBB. You are not bound by the decision, and may reject the decision and proceed to court where all findings of the BBB Auto Line dispute, and decision, are admissible in the court action. Should you choose to accept the BBB AUTO LINE decision, Ford is then bound by the decision, and must comply with the decision within 30 days of receipt of your acceptance letter.

BBB AUTO LINE Application: Using the information that follows, call or write to request a program application. You will be asked for your name and address, general information about your new vehicle, information about your warranty concerns, and any steps you have already taken to try to resolve them. A Customer Claim Form will be mailed that needs to be completed, signed and returned to the BBB along with proof of ownership. Upon receipt, the BBB reviews the claim for eligibility under the Program Summary Guidelines.

Customer Information

You can get more information by calling BBB AUTO LINE at 1-800-955-5100, or writing to:

**BBB AUTO LINE a Division of BBB National Programs, Inc.
1676 International Drive, Suite 550
McLean, VA 22102**

BBB AUTO LINE applications can also be requested by calling the Ford Motor Company Customer Relationship Center at 1-800-392-3673.

For additional information, refer to the Better Business Bureau website.

Note: *Ford Motor Company reserves the right to change eligibility limitations, modify procedures, or to discontinue this process at any time without notice and without obligation.*

THE MEDIATION AND ARBITRATION PROGRAM - CANADA

For vehicles delivered to authorized Canadian dealers. In those cases where you continue to feel that the efforts by Ford of Canada and the authorized dealer to resolve a factory-related vehicle service concern have been unsatisfactory, Ford of Canada participates in an impartial third party mediation/arbitration program administered by the Canadian Motor Vehicle Arbitration Plan (CAMVAP).

The CAMVAP program is a straightforward and relatively speedy alternative to resolve a disagreement when all other efforts to produce a settlement have failed. This procedure is without cost to you and is designed to eliminate the need for lengthy and expensive legal proceedings.

In the CAMVAP program, impartial third-party arbitrators conduct hearings at mutually convenient times and places in an informal environment. These impartial arbitrators review the positions of the parties, make decisions and, when appropriate, render awards to resolve disputes. CAMVAP decisions are fast, fair, and final as the arbitrator's award is binding on both you and Ford of Canada.

CAMVAP services are available in all Canadian territories and provinces. For more information, without charge or obligation, call your CAMVAP Provincial Administrator directly at 1-800-207-0685 or visit www.camvap.ca.

REPORTING SAFETY DEFECTS IN THE UNITED STATES

If you believe that your vehicle has a defect which could cause a crash or could cause injury or death, you should immediately inform the National Highway Traffic Safety Administration (NHTSA) in addition to notifying Ford Motor Company.

Customer Information

If NHTSA receives similar complaints, it may open an investigation, and if it finds that a safety defect exists in a group of vehicles, it may order a recall and remedy campaign. However, NHTSA cannot become involved in individual problems between you, your dealer, or Ford Motor Company.

To contact NHTSA, you may call the Vehicle Safety Hotline toll-free at 1-888-327-4236 (TTY: 1-800-424-9153); go to www.safercar.gov; or write to:

Administrator

1200 New Jersey Avenue, Southeast
Washington, D.C. 20590

You can also obtain other information about motor vehicle safety from www.safercar.gov.

REPORTING SAFETY DEFECTS IN CANADA

If you believe that your vehicle has a defect which could cause a crash or could cause injury or death, you should immediately inform Transport Canada and Ford of Canada.

Transport Canada Contact Information

Website (English)	http://tc.canada.ca/recalls
Website (French)	http://tc.canada.ca/rappels
Phone	1-800-333-0510

Ford of Canada Contact Information

Website	www.ford.ca
Phone	1-800-565-3673

Customer Information

RADIO FREQUENCY CERTIFICATION LABELS

BLIND SPOT INFORMATION SYSTEM SENSORS

Device	Supplier	Type Designation
SRR5 BLIS Corner Radar (RRU2)	Aptiv	2F5TR

Argentina

H-28070

15375-23-12270



Brazil



China

CMIIT ID: 2023LJ10407

Djibouti

AGREE PAR LE MCPT (REPUBLIQUE DE DJIBOUTI)

Numéro d'agrément:

040/DDTIC/2024

Date d'agrément:

16/04/2024

Customer Information

Europe Union EU



Ghana

NCA APPROVED: 7E6-M0-XDF-TME

Indonesia

Sertifikat Nomor: 98785/SDPPI/2024
PLG ID: 13493



Jamaica

This product has been Type Approved by
Jamaica: SMA - 2F5TR.

Mauritania

AGREE PAR L'ANE MAURITANIE

Numéro d'agrément:

1222/ARE/2023

Date d'agrément:

06/02/2023

Mexico

IFT: ROAP2F23-27117

Morocco

AGREE PAR L'ANRT MAROC

Numéro d'agrément:

MR00036523ANRT2023

Date d'agrément:

30/01/23

Paraguay



NR: 2022-04-I-0255

South Africa



Customer Information

South Korea



R-C-1Ap-2F5TR

Taiwan



CCA123LP0640T2

United Arab Emirates (U.A.E.)

 <p>ER10085/22 United Arab Emirates</p>	
--	--

Customer Information

United Kingdom



United States and Canada

FCC ID: L2C2F5TR

IC: 3432A-2F5TR

This equipment generates, uses, and can radiate radio frequency energy and may cause harmful interference to radio communications. There is no guarantee that interference will not occur in a particular installation. If this equipment does cause harmful interference to radio or television reception, please consult the dealer.

This product is not end-user serviceable.

RF Radiation Exposure Statement: This equipment complies with FCC RF Radiation exposure limits set forth for an uncontrolled environment. This device and its antenna must not be co-located or operating in conjunction with any other antenna or transmitter. This equipment should be installed and operated with a minimum distance of 20cm between the radiator and your body.

This device complies with Part 15 of the FCC Rules and with Innovation, Science and Economic Development Canada's licence-exempt RSS(s). Operation is subject to the following two conditions:

1. This device may not cause harmful interference, and
2. This device must accept any interference received, including interference that may cause undesired operation.

Le présent appareil est conforme aux CNR d'Industrie Canada applicables aux appareils radio exempts de licence. L'exploitation est autorisée aux deux conditions suivantes:

- 1. L'appareil ne doit pas produire de brouillage;*
- 2. L'appareil doit accepter tout brouillage radioélectrique subi, même si le brouillage est susceptible d'en compromettre le fonctionnement.*

Customer Information

BLIND SPOT INFORMATION SYSTEM SENSORS

Device	Supplier	Type Designation
SRR5 BLIS Corner Radar	Aptiv	F5TR

Argentina



Brazil



China

CMIIT ID: 2022LP14250

Djibouti

AGREE PAR LE MCPT (REPUBLIQUE DE DJIBOUTI)
Numéro d'agrément : 195/MCPT/DDTIC
Date d'agrément : 06/09/2021

Customer Information

Europe Union EU



Indonesia

Sertifikat Nomor: 90715/SDPPI/2023
PLG ID: 13493



Mauritania

AGREE PAR L'ANEMAURITANIE
Numéro d'agrément : 0985/ARE/2021
Date d'agrément : 24/08/2021

Ghana

NCA APPROVED: SRO-1M-7E4-XOE

Jamaica

This product has been Type Approved by Jamaica: SMA – FSTR.

Customer Information

Mexico

IFETEL: RCPAPF520-0480

Morocco

AGREE PAR L'ANRT MAROC
Numéro d'agrément : MR00030033ANRT2021
Date d'agrément : 16/09/2021

Paraguay



NR: 2020-10-I-0753

Singapore

Complies with IMDA Standards

DA 00461

Customer Information

South Africa



Taiwan



Ukraine



South Korea



Thailand

- (1) เครื่องใช้โทรคมนาคมและอุปกรณ์อื่น ๆ มีความสอดคล้องตามข้อกำหนดของ กทท.
- (2) เครื่องใช้โทรคมนาคมและระบบการเคลื่อนที่แบบเคลื่อนที่ไร้สายที่สอดคล้องตามมาตรฐานความปลอดภัยต่อสุขภาพของมนุษย์จากการใช้คลื่นวิทยุความถี่สูงที่คณะกรรมการกิจการโทรคมนาคมแห่งชาติประกาศ

Customer Information

United Arab Emirates (U.A.E.)



United Kingdom



United States and Canada

FCC ID: L2CF5TR
IC: 3432A-F5TR

Customer Information

This device complies with Part 15 of the FCC Rules and with Innovation, Science and Economic Development Canada's licence-exempt RSS(s). Operation is subject to the following two conditions:

1. This device may not cause harmful interference, and
2. This device must accept any interference received, including interference that may cause undesired operation.

L'émetteur/récepteur exempt de licence contenu dans le présent appareil est conforme aux CNR d'Innovation, Sciences et Développement économique Canada applicables aux appareils radio exempts de licence. L'exploitation est autorisée aux deux conditions suivantes:

1. L'appareil ne doit pas produire de brouillage;
2. L'appareil doit accepter tout brouillage radioélectrique subi, même si le brouillage est susceptible d'en compromettre le fonctionnement.

Note: Changes or modifications not expressly approved by the party responsible for compliance could void the user's authority to operate the equipment.

Nota: Tout changement apporté au dispositif sans l'approbation expresse des autorités compétentes pourrait révoquer le droit de l'utilisateur d'en faire usage.

Customer Information

Vietnam

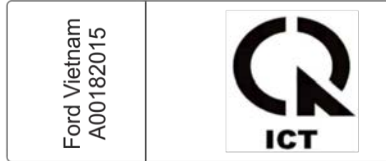

BODY CONTROL MODULE

Device	Supplier	Type Designation
Gen 1 Body Control Module	Continental	M3NA2C738448

Customer Information

Argentina



Ghana

NCA APPROVED: NCA/TA/16/23

Jamaica

This product has been Type Approved by
Jamaica: SMA - M3NA2C738448.

Morocco

AGREE PAR L'ANRT MAROC
Numéro d'agrément: MR 8925 ANRT 2014
Date d'agrément: 04/02/2014

Djibouti

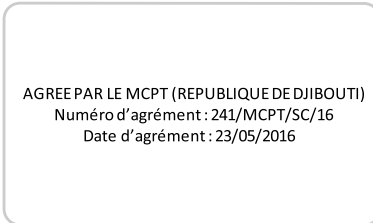

Mauritania



Pakistan

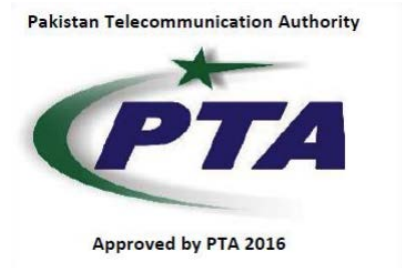

Customer Information

Paraguay



2018-08-I-000410
2013-08-I-0158

South Africa



South Korea



2013-07-03

Syria



Ukraine



Customer Information

United States and Canada

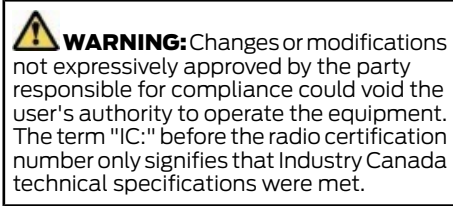

FCC ID: M3NA2C738448

IC: 7812A-A2C738448

This device complies with Part 15 of the FCC Rules and with Innovation, Science and Economic Development Canada's licence-exempt RSS(s). Operation is subject to the following two conditions:

1. This device may not cause harmful interference, and
2. This device must accept any interference received, including interference that may cause undesired operation.

CRUISE CONTROL MODULE

Device	Supplier	Type Designation
MRR3 Medium Range Radar	Aptiv	F3TR

Vietnam

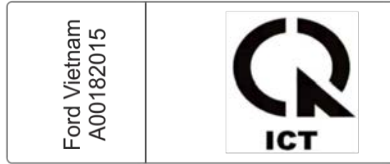

Zambia



Customer Information

Argentina



Djibouti

AGREE PAR LE MCPT (REPUBLIQUE DE DJIBOUTI)
Numéro d'agrément : 059/DDTIC/2020
Date d'agrément : 01/10/2020

Europe Union EU

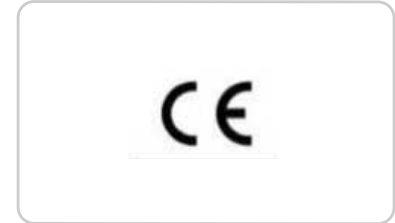

Brazil



EAC Marking - Russia, Belarus, Kazakhstan



Ghana



Customer Information

Independent State Of Samoa



Indonesia

Sertifikat Nomor: 90714/SDPPI/2023
PLG ID: 13493



Israel

1. מספר אישור התאמה מסעם משרד התקשורת: 51-82320
2. תח אישור לבצע פעולות במכשיר ישו בוין כדי לשנות את התכונות האולחיות של המכשיר, ובכלל זה שינוי תוכנה, החלפת אנטנה מקרית או הוספת אפשרות לחיבור לאנטנה חיצונית, בלא קבלת אישור משרד התקשורת, כשל החשש להפרצות אלוטיות.

Jamaica

This product has been Type Approved by Jamaica: SMA – F3TR.

Malaysia



HIDF16000009

Mauritania

AGREE PAR L'ANE MAURITANIE
Numéro d'agrément : 0835/ARE/2020
Date d'agrément : 31/08/2020

Customer Information

Mexico

IFT: RCPAPF320-0479

Moldova



Morocco

AGREE PAR L'ANRT MAROC

Numéro d'agrément:
MR00030034ANRT2021

Date d'agrément: 16/09/2021

Pakistan



Paraguay



NR: 2020-10-I-0752

Sierra Leone



Customer Information

TAN: 2021-002-0028

Singapore

Complies with IMDA Standards

DA 00461

South Korea



R-C-1Ap-F3TR

Taiwan



Thailand

- (1) เครื่องใช้โทรคมนาคมและอุปกรณ์นี้ มีความสอดคล้องตามข้อกำหนดของ กทท.
 - (2) เครื่องใช้โทรคมนาคมและอุปกรณ์นี้ได้รับการแต่งตั้งให้ใช้ที่สอดคล้องกับมาตรฐานความถี่ของข่ายข้อมูลภาคพื้นดินของประเทศไทย
- หากการไม่ใช้ เครื่องใช้โทรคมนาคมที่ผ่านการพิจารณาของ กทท. อาจส่งผลกระทบต่อการใช้งาน

Ukraine



South Africa



Customer Information

Unites Arab Emirates (U.A.E.)



United Kingdom



United States and Canada

FCC ID: L2CF3TR
IC: 3432A-F3TR

Customer Information

This device complies with Part 15 of the FCC Rules and with Innovation, Science and Economic Development Canada's licence-exempt RSS(s). Operation is subject to the following two conditions:

1. This device may not cause harmful interference, and
2. This device must accept any interference received, including interference that may cause undesired operation.

L'émetteur/récepteur exempt de licence contenu dans le présent appareil est conforme aux CNR d'Innovation, Sciences et Développement économique Canada applicables aux appareils radio exempts de licence. L'exploitation est autorisée aux deux conditions suivantes:

1. L'appareil ne doit pas produire de brouillage;
2. L'appareil doit accepter tout brouillage radioélectrique subi, même si le brouillage est susceptible d'en compromettre le fonctionnement.

Note: Changes or modifications not expressly approved by the party responsible for compliance could void the user's authority to operate the equipment.

Nota: Tout changement apporté au dispositif sans l'approbation expresse des autorités compétentes pourrait révoquer le droit de l'utilisateur d'en faire usage.

Customer Information

Zambia



OPERATING SYSTEM

Device	Supplier	Type Designation
PDC	Ford	SG5PHX

Customer Information

Jamaica

This product has been Type Approved by
Jamaica: SMA – SG5PHX

NR: 2023-06-I-0457

R-C-FDM-SG5PHX

Paraguay



South Korea



Customer Information

United Arab Emirates (U.A.E.)



United States and Canada

FCC ID: KMH SG5PHX

IC: 1422A SG5PHX

This device complies with Part 15 of the FCC Rules and with ISED Canada license-exempt RSSs. Operation is subject to the following two conditions:

- 1. This device may not cause harmful interference, and***
- 2. This device must accept any interference received, including interference that may cause undesired operation.***

Le présent appareil est conforme aux CNR d'ISED Canada applicables aux appareils radio exempts de licence. L'exploitation est autorisée aux deux conditions suivantes:

- 1. L'appareil ne doit pas produire de brouillage;***
- 2. L'appareil doit accepter tout brouillage radioélectrique subi, même si le brouillage est susceptible d'en compromettre le fonctionnement.***

Note: *Changes or modifications not expressly approved by the party responsible for compliance could void the user's authority to operate the equipment.*

RF Radiation Exposure Statement: This equipment complies with FCC RF Radiation exposure limits set forth for an uncontrolled environment. This device and its antenna must not be co-located or operating in conjunction with any other antenna or transmitter. This equipment should be installed and operated with a normally maintained separation distance of at least 20cm between the radiator and your body.

Customer Information

PASSIVE KEY

Device	Supplier	Type Designation
Motion Sense Passive Key	Continental	A3C054342

Argentina



H-25996

Ghana

NCA APPROVED: SRO-1M-7E4-107

Israel

1. מספר אישור התאמה מסעם משרד התקשורת: 51-74154
 2. חל אישור לבצוע פעולות בפסג'ר שיש בהן כדי לשנות את תכונותיה האלקטרוט של המכשיר, ובכלל זה שינוי תכונה, החלפת אנטנה מקורית או הוספת אפשרות לחיבור לאנטנה חיצונית, בלא קבלת אישור משרד התקשורת, כשל החשש להפרעת אלקטרוט.

Morocco

AGREE PAR L'ANRT MAROC

Numéro d'agrément:
 MR00027379ANRT2021

Date d'agrément: 10/02/2021

Paraguay



Customer Information

NR: 2020-09-I-0618

Serbia

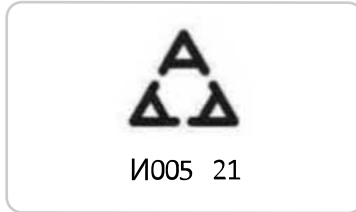

Sierra Leone



TAN: 2021-002-0049

Singapore

Complies with IMDA Standards

Dealer License Number:

DA 00461

South Korea



R-C-TAL-A3C054342

United Arab Emirates (U.A.E.)

TRA REGISTERED No:

ER81340/20

DEALER No:

DA88113/20

Customer Information

United Kingdom



PASSIVE KEY

Device	Supplier	Type Designation
Passive Key Transmitter	Continental	A3C108397

Customer Information

Argentina

(RAMATEL Isologotype)



RAMATEL H-28042

(RAMATEL Isotype)



(RAMATEL Isologotype)

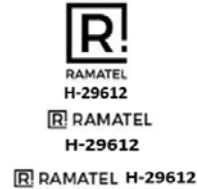

(RAMATEL Isotype)



(RAMATEL Isologotype)

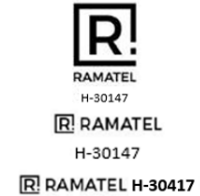

(RAMATEL Isotype)



Brazil



Customer Information

03184-23-06546

Israel

1. מספר אישור התאמה מסוג משרד התקשורת: **51-85634**
2. חל אישור לבצע פעולות במסגרת שיש בהן כדי לשנות את תכונות האלמנטים של המכשיר, ובכלל זה שינוי תכנית, החלפת אלמנט מקורי או הוספת אישורת לריכוז לאנטנה חיצונית, כלא בקבלת אישור משרד התקשורת, בעל הששם להפרעות אלווסיות.

Jamaica

This product has been Type Approved by Jamaica: SMA – M3N-A3C108397

Paraguay



NR: 2022-03-I-0162

Serbia



Singapore

Complies with IMDA Standards

Dealer License Number:

DA 00461

Customer Information

South Africa



Taiwan

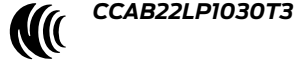

Thailand

(1) หรือมีโทรคมนาคมและอุปกรณ์ที่มีคุณสมบัติเฉพาะจากกำหนดของ กทท.

(2) หรือมีคุณสมบัติการแผ่คลื่นแม่เหล็กไฟฟ้าที่สอดคล้องตามมาตรฐานความปลอดภัยต่อสุขภาพของมนุษย์จากคลื่นแม่เหล็กวิทยุคมนาคมที่คณะกรรมการกิจการโทรคมนาคมแห่งชาติประกาศกำหนด

United Arab Emirates (U.A.E.)



Customer Information

United Kingdom



United States and Canada

FCC ID: M3N-A3C108397

IC ID: 7812A-A3C108397

This device complies with Part 15 of the FCC Rules and with Innovation, Science and Economic Development Canada's licence-exempt RSS(s). Operation is subject to the following two conditions:

1. This device may not cause harmful interference, and
2. This device must accept any interference received, including interference that may cause undesired operation.

L'émetteur/récepteur exempt de licence contenu dans le présent appareil est conforme aux CNR d'Innovation, Sciences et Développement économique Canada applicables aux appareils radio exempts de licence. L'exploitation est autorisée aux deux conditions suivantes:

1. L'appareil ne doit pas produire de brouillage;
2. L'appareil doit accepter tout brouillage radioélectrique subi, même si le brouillage est susceptible d'en compromettre le fonctionnement.

Note: Changes or modifications not expressly approved by the party responsible for compliance could void the user's authority to operate the equipment.

Nota: Tout changement apporté au dispositif sans l'approbation expresse des autorités compétentes pourrait révoquer le droit de l'utilisateur d'en faire usage.

Customer Information

RADIO TRANSCEIVER MODULE

Device	Supplier	Type Designation
Radio Transceiver Module (RTM)	Aptiv	FO2-RX433UDA

Democratic Republic of Congo

Agréé par l'ARPTC

N° d'homologation:

HER - 0151/Septembre/2022

Date d'homologation:

22/09/2022

Djibouti

AGREE PAR LE MCPT (REPUBLIQUE DE
DJIBOUTI)

Numéro d'agrément:

033/DDTIC/2020

Date d'agrément:

07/06/2020

Europe Union EU

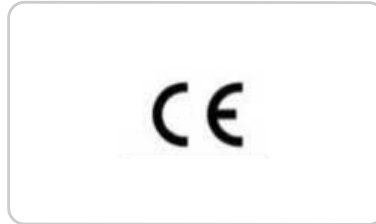

Customer Information

Ghana

NCA PRODUCT IDENTIFIERS: SRO-1M-7E4-108

Jamaica

This product has been Type Approved by Jamaica: SMA – FO2-RX433UDA

Independent State of Samoa



Israel

1. מספר אישור התאמה מסעם משרד התקשורת: 51-4627
2. חל אישור לבצע פעולות בסכשיר שיש בהן כדי לשנות את תכונותיו האלחוטיות של הסכשיר, ובכלל זה שינוי תכונה, החלפת אנטנה מקורית או הוספת אפשרות לחיבור לאנטנה זרימנית, בלא קבלת אישור משרד התקשורת, בשל החשש להפרעות אלחוטיות.

1. מספר אישור התאמה מסעם משרד התקשורת: 56-03001
2. חל אישור לבצע פעולות בסכשיר שיש בהן כדי לשנות את תכונותיו האלחוטיות של הסכשיר, ובכלל זה שינוי תכונה, החלפת אנטנה מקורית או הוספת אפשרות לחיבור לאנטנה זרימנית, בלא קבלת אישור משרד התקשורת, בשל החשש להפרעות אלחוטיות.

Malaysia



HIDF16000009

Mauritania

AGREE PAR L'ANE MAURITANIE

Numéro d'agrément:

0803/ARE/2020

Date d'agrément:

03/06/2020

Customer Information

Mexico



IFT: RCPAPFO21-0004

Moldova



Morocco



Serbia



Pakistan



South Africa



Customer Information

Taiwan



CCAB22LP1370T1

Thailand

บริษัท โทรคมนาคมแห่งชาติ จำกัด (มหาชน) โทร. 1111

Ukraine



United Kingdom



Customer Information

United Arab Emirates (U.A.E.)



Zambia



Customer Information

TELEMATICS CONTROL UNIT

Device	Supplier	Type Designation
Telematics Control Unit	Ford	FNV3-B6-NA FNV3-B6-ROW FNV3-B6-C FNV3-B6-C-V2X

Argentina



C-29802

China

CMIIT ID: 2023CJ1792
CMIIT ID: 2023CJ15969
CMIIT ID: 2023CJ1792
CMIIT ID: 2024CJ0557

European Union EU



Customer Information

Malaysia



HIDF16000009

Mexico



Paraguay



NR: 2023-01-I-0047

Serbia



Customer Information

South Africa



South Korea



R-C-FDM-FNV3B6ROW

Taiwan



CCA235G0042T9

We recommend that the distance between the antenna of the telematics control unit and the user be greater than 14 in (35 cm) when using the telematics control unit.

United Arab Emirates (U.A.E.)



Customer Information

United Kingdom



United States and Canada

FCC ID: KMH-14H317-NA1

IC: 1422A-14H317NA1

This device complies with Part 15 of the FCC Rules and with Innovation, Science and Economic Development Canada's licence-exempt RSS(s). Operation is subject to the following two conditions:

1. This device may not cause harmful interference, and
2. This device must accept any interference received, including interference that may cause undesired operation.

L'émetteur/récepteur exempt de licence contenu dans le présent appareil est conforme aux CNR d'Innovation, Sciences et Développement économique Canada applicables aux appareils radio exempts de licence. L'exploitation est autorisée aux deux conditions suivantes:

1. L'appareil ne doit pas produire de brouillage;
2. L'appareil doit accepter tout brouillage radioélectrique subi, même si le brouillage est susceptible d'en compromettre le fonctionnement.

Note: Changes or modifications not expressly approved by the party responsible for compliance could void the user's authority to operate the equipment.

Nota: Tout changement apporté au dispositif sans l'approbation expresse des autorités compétentes pourrait révoquer le droit de l'utilisateur d'en faire usage.

Customer Information

Vietnam



TIRE PRESSURE MONITORING SYSTEM SENSORS

Device	Supplier	Type Designation
Burnell TPM Sensor	Schrader/Sensata	BG2BP4

Customer Information

Argentina

CNC ID: H-28035

13309-22-08001



Brazil



European Union EU

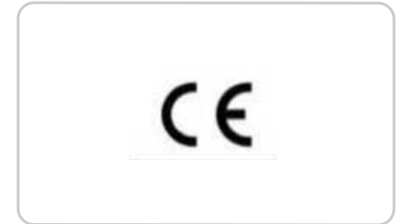

The RED 2014/53/EU (replacing R&TTE Directive 1999/5/EC on 13 June 2016) explicitly states that instructions for intentional radiators include reference to "(a) frequency band(s) in which the radio equipment operates; and (b) maximum radio-frequency power transmitted in the frequency band(s) in which the radio equipment operates," in addition to carrying over the general operational instruction and Declaration of Conformity inclusion requirements from the R&TTE Directive.

Hereby, Schrader Electronics Ltd. declares that the radio equipment type BG2BP4 is in compliance with Directive 2014/53/EU. The full text of the EU declaration of conformity is available at the following internet address:

<https://www.schradertpms.com/en-gb/downloads>

Customer Information

f=433.92MHz

P<10mW (e.i.r.p)

Schrader Electronics Ltd. 11 Technology Park, Belfast Road, Antrim BT41 1QS, Northern Ireland United Kingdom.

Israel

1. מספר אישור התאמה מסעם משרד התקשורת: 51-86230
2. תל אישור לבצע פעולות במסגרת שיש בהן כדי לשנות את הכוונות האלחוטיות של המכשיר, ובכלל זה שינוי תוכנה, החלפת אנטנה מקורית או הוספת אפשרות לחיבור לאנטנה חיצונית, בלא קבלת אישור משרד התקשורת, בשל החשש להפרעות אלחוטיות.

Jamaica

This product has been Type Approved by Jamaica: SMA - BG2BP4.

Malaysia



HIDF16000009

Mexico

IFT: RLVSCBG22-2502

Moldova



Morocco

AGREE PAR L'ANRT MAROC

Numéro d'agrément:
MR00034968ANRT2022

Date d'agrément: 21/12/2022

Customer Information

Paraguay



NR: 2022-05-I-0000331

Serbia



Singapore

Complies with IMDA Standards

DA 00461

South Africa



Customer Information

South Korea



MSIP-R-C-SRD-BG2BP4

Taiwan



CCAB22LP0730T0

Thailand

- (1) เครื่องโทรคมนาคมและอุปกรณ์เหล่านี้ มีความสอดคล้องตามข้อกำหนดของ กทท.
- (2) เครื่องวิทยุคมนาคมนี้จะมีประสิทธิภาพดีเยี่ยมถึงสี่ในห้าที่สอดคล้องตามมาตรฐานความปลอดภัยของวิทยุคมนาคมแห่งชาติ หากการใช้งานเครื่องวิทยุคมนาคมนี้สอดคล้องตามข้อกำหนดแห่งชาติที่โทรคมนาคมแห่งชาติ ปีประกาศกำหนด

Ukraine



Customer Information

Unites Arab Emirates (U.A.E.)



United Kingdom



United States and Canada

FCC ID: MRXBG2BP4

IC: 2546A-BG2BP4

Customer Information

This device complies with Part 15 of the FCC Rules and with Innovation, Science and Economic Development Canada's licence-exempt RSS(s). Operation is subject to the following two conditions:

1. This device may not cause harmful interference, and
2. This device must accept any interference received, including interference that may cause undesired operation.

L'émetteur/récepteur exempt de licence contenu dans le présent appareil est conforme aux CNR d'Innovation, Sciences et Développement économique Canada applicables aux appareils radio exempts de licence. L'exploitation est autorisée aux deux conditions suivantes:

1. L'appareil ne doit pas produire de brouillage;
2. L'appareil doit accepter tout brouillage radioélectrique subi, même si le brouillage est susceptible d'en compromettre le fonctionnement.

Note: Changes or modifications not expressly approved by the party responsible for compliance could void the user's authority to operate the equipment.

Note: Tout changement apporté au dispositif sans l'approbation expresse des autorités compétentes pourrait révoquer le droit de l'utilisateur d'en faire usage.

TIRE PRESSURE MONITORING SYSTEM SENSORS

Device	Supplier	Type Designation
434 Faraday Gen 6 TPMS Sensor	Schrader/Sensata	FP4

Customer Information

Argentina



China

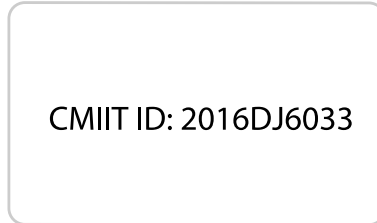

Democratic Republic of Congo

Agréé par l'ARPTC
N° d'homologation: HIR-0099/09/2016
Date d'homologation: 15/09/2016

Djibouti



European Union (EU)

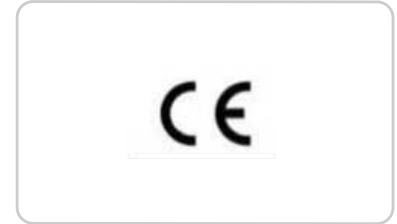

Customer Information

The RED 2014/53/EU (replacing R&TTE Directive 1999/5/EC on 13 June 2016) explicitly states that instructions for intentional radiators include reference to "(a) frequency band(s) in which the radio equipment operates; and (b) maximum radio-frequency power transmitted in the frequency band(s) in which the radio equipment operates," in addition to carrying over the general operational instruction and Declaration of Conformity inclusion requirements from the R&TTE Directive.

Hereby, Schrader Electronics Ltd. declares that the radio equipment type FP4 is in compliance with Directive 2014/53/EU. The full text of the EU declaration of conformity is available at the following internet address:

<https://www.schradertpms.com/en-gb/downloads>

f=433.92MHz

P<10mW (e.i.r.p)

Schrader Electronics Ltd. 11 Technology Park, Belfast Road, Antrim BT41 1QS, Northern Ireland United Kingdom.

Ghana

Independent State of Samoa

Israel

NCA APPROVED: 2R9-8M-7E0-0BE



1. מספר אישור התאמה סטנדר התקשורת: 51-83847
2. חל אישור לכצע פעולות במכשיר שיש בהן כדי לשנות את תכונותיו האלחוטיות של המכשיר, ובכלל זה שינוי תוכנת, החלפת אנטנה סקורית או הוספת אפשרות לחיבור לאנטנה יציבות, בלא בקבלת אישור משרד התקשורת, כשל החשש להפרעות אלחוטיות.

Customer Information

Jamaica

This product has been Type Approved by Jamaica: SMA - FP4.

Mauritania

AGREE PAR L'ANE MAURITANIE
Numéro d'agrément : 0358/ARE/2016
Date d'agrément : 04/10/2016

Moldova



Nigeria

Connection and use of this communications equipment is permitted by the Nigerian Communications Commission

Oman

OMAN TRA
TA-R/3591/16
D080134

Pakistan



Paraguay



Customer Information

Serbia

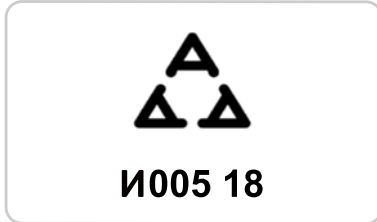

Sierra Leone



TAN: 2016-002-0035

South Korea



MSIP-CRM-SRD-FP4

Ukraine



Customer Information

Unites Arab Emirates (U.A.E.)



United Kingdom



United States and Canada

FCC ID: MRXFP4

IC: 2546A-FP4

Customer Information

This device complies with Part 15 of the FCC Rules and with Innovation, Science and Economic Development Canada's licence-exempt RSS(s). Operation is subject to the following two conditions:

1. This device may not cause harmful interference, and
2. This device must accept any interference received, including interference that may cause undesired operation.

L'émetteur/récepteur exempt de licence contenu dans le présent appareil est conforme aux CNR d'Innovation, Sciences et Développement économique Canada applicables aux appareils radio exempts de licence. L'exploitation est autorisée aux deux conditions suivantes:

1. L'appareil ne doit pas produire de brouillage;
2. L'appareil doit accepter tout brouillage radioélectrique subi, même si le brouillage est susceptible d'en compromettre le fonctionnement.

Note: Changes or modifications not expressly approved by the party responsible for compliance could void the user's authority to operate the equipment.

Nota: Tout changement apporté au dispositif sans l'approbation expresse des autorités compétentes pourrait révoquer le droit de l'utilisateur d'en faire usage.

WIRELESS ACCESSORY CHARGING MODULE

Device	Supplier	Type Designation
Wireless Charger (WCM)	LG/BH EVS	WCFDM00N2A1 WCFDM00N2A3 WCFDM00N2A5

Customer Information

Argentina



Democratic Republic of Congo

Agréé par l'ARPTC

N° d'homologation: HER-062/Avril/2023

Date d'homologation: 28/4/2023

European Union



Brazil



Customer Information

Ghana

NCA APPROVED: 7ES-7M-XB1-RDR

Model: WCFDM00N2A3
Sertifikat Nomor: 80111/SDPPI/2022
PLG ID: 13493



Israel

1. מספר אישור החאמה מטעם משרד התקשורת: 51-80014
2. תל איסור לבצע פעולות במכשיר שיש בהן כדי לשנות את תכונותיו האלחוטיות של המכשיר, ובכלל זה שינוי תוכנה, החלפת אנטנה מקורית או הספת אפשרות לחיבור לאנטנה חיצונית, בלא קבלת אישור משרד התקשורת, בעל החשש להפרעות אלחוטיות

Indonesia

Model: WCFDM00N2A1
Sertifikat Nomor: 80110/SDPPI/2022
PLG ID: 13493



Model: WCFDM00N2A5
Sertifikat Nomor: 80112/SDPPI/2022
PLG ID: 13493



1. מספר אישור החאמה מטעם משרד התקשורת: 51-80015
2. תל איסור לבצע פעולות במכשיר שיש בהן כדי לשנות את תכונותיו האלחוטיות של המכשיר, ובכלל זה שינוי תוכנה, החלפת אנטנה מקורית או הספת אפשרות לחיבור לאנטנה חיצונית, בלא קבלת אישור משרד התקשורת, בעל החשש להפרעות אלחוטיות

Customer Information

Malaysia



HIDF16000009

Mauritania

AGREE PAR L'ANE MAURITANIE
Numéro d'agrément : 0935/ARE/2021
Date d'agrément : 23/03/2021

AGREE PAR L'ANE MAURITANIE
Numéro d'agrément : 0934/ARE/2021
Date d'agrément : 23/03/2021

1. מספר אישור התאמה מסעם משרד התקשורת : 51-80013
2. חול אישור לבצע פעולות במשקף שיש בוין כדי לשנות את תכונותיו האלחוטיות של המכשיר, ובכלל זה שינוי תמננת, הולפת אנטנה מקורית או הוספת אפישרת לחיבור לאנטנה חיצונית, בלא קבלת אישור משרד התקשורת, בשל החשש להפרעת אלחוטיות

Jamaica

This product has been Type Approved by Jamaica:
SMA - WCFDM00N2A.

Customer Information

Morocco

AGREE PAR L'ANEMAURITANIE
Numéro d'agrément : 0933/ARE/2021
Date d'agrément : 23/03/2021

AGREE PAR L'ANRT MAROC
Numéro d'agrément : MR 00027924ANRT 2021
Date d'agrément : 25/03/2021

AGREE PAR L'ANRT MAROC
Nu mero d'agrément : MR 00027923ANRT 2021
Date d'agrément : 25/03/2021

Moldova



AGREE PAR L'ANRT MAROC
Nu mero d'agrément : MR 00027925ANRT 2021
Date d'agrément : 25/03/2021

Paraguay



Customer Information

NR: 2021-04-I-0202

NR: 2021-04-I-0203

NR: 2021-04-I-0204

Russia



Serbia



V005 21

Sierra Leone



TAN: 2021-002-0099

Singapore

Complies with IMDA Standards

DA 00461

South Africa



South Korea



Customer Information

R-R-LGE-WCFDM00N2A1

Taiwan



CCAB21LP050AT3



CCAB21LP050BT5



CCAB21LP0500T1

品名 (Product name): 無線充電座

型號 (Type Designation): WCFDM00N2A1, WCFDM00N2A3, WCFDM00N2A5 **產地 (Origin):** 馬來西亞

額定電壓 (Input rating): 12V

製造日期 (Approval date): 2021.04.21



R43208
Rolls

申請廠商名稱 (Approval name): 福特六和汽車股份有限公司

申請廠商地址 (Approval address): 桃園市中壢區中華路一段705號

Customer Information

Ukraine



United Kingdom



United Arab Emirates (U.A.E.)



Customer Information

TDR^Λ

ER00421/21
United Arab Emirates



TDR^Λ

ER00421/21
United Arab Emirates



IC: 2703H-WCFDM00N2A

United States and Canada

FCC ID: BEJWCDFM00N2A

Customer Information

This equipment generates, uses, and can radiate radio frequency energy and may cause harmful interference to radio communications. There is no guarantee that interference will not occur in a particular installation. If this equipment does cause harmful interference to radio or television reception, please consult the dealer.

This product is not end-user serviceable.

RF Radiation Exposure Statement: This equipment complies with FCC RF Radiation exposure limits set forth for an uncontrolled environment. This device and its antenna must not be co-located or operating in conjunction with any other antenna or transmitter. This equipment should be installed and operated with a minimum distance of 20cm between the radiator and your body.

This device complies with Part 15 of the FCC Rules and with Innovation, Science and Economic Development Canada's licence-exempt RSS(s). Operation is subject to the following two conditions:

1. This device may not cause harmful interference, and
2. This device must accept any interference received, including interference that may cause undesired operation.

Le présent appareil est conforme aux CNR d'Industrie Canada applicables aux appareils radio exempts de licence. L'exploitation est autorisée aux deux conditions suivantes:

1. *L'appareil ne doit pas produire de brouillage;*
2. *L'appareil doit accepter tout brouillage radioélectrique subi, même si le brouillage est susceptible d'en compromettre le fonctionnement.*

Customer Information

Vietnam



PERCHLORATE

Certain components in your vehicle such as airbag modules, seatbelt pretensioners and remote control batteries may contain perchlorate material. Special handling may apply for service or vehicle end of life disposal.

For more information visit:
www.dtsc.ca.gov/hazardouswaste/perchlorate.

REPLACEMENT PARTS RECOMMENDATION

We have built your vehicle to the highest standards using quality parts. We recommend that you demand the use of genuine Ford and Motorcraft parts whenever your vehicle requires scheduled maintenance or repair. You can clearly identify genuine Ford and Motorcraft parts by looking for the Ford, FoMoCo or Motorcraft branding on the parts or their packaging.

Scheduled Maintenance and Mechanical Repairs

One of the best ways for you to make sure that your vehicle provides years of service is to have it maintained in line with our recommendations using parts that conform to the specifications detailed in this Owner's Manual.

Genuine Ford and Motorcraft parts meet or exceed these specifications.

Collision Repairs

We hope that you never experience a collision, but accidents happen sometimes.

Genuine Ford replacement collision parts meet our stringent requirements for fit, finish, structural integrity, corrosion protection and dent resistance. During vehicle development we validate that these parts deliver the intended level of protection as a whole system. A great way to know for sure you are getting this level of protection is to use genuine Ford replacement collision parts.

Warranty on Replacement Parts

Genuine Ford and Motorcraft replacement parts are the only replacement parts that benefit from a Ford Warranty.

Zambia



Customer Information

The Ford Warranty may not cover damage caused to your vehicle as a result of failed non-Ford parts.

For additional information, refer to the terms and conditions of the Ford Warranty.

MOBILE COMMUNICATIONS EQUIPMENT



WARNING: Driving while distracted can result in loss of vehicle control, crash and injury. We strongly recommend that you use extreme caution when using any device that may take your focus off the road. Your primary responsibility is the safe operation of your vehicle. We recommend against the use of any hand-held device while driving and encourage the use of voice-operated systems when possible. Make sure you are aware of all applicable local laws that may affect the use of electronic devices while driving.

Using mobile communications equipment is becoming increasingly important in the conduct of business and personal affairs. However, you must not compromise your own or others' safety when using such equipment. Mobile communications can

enhance personal safety and security when appropriately used, particularly in emergency situations. Safety must be paramount when using mobile communications equipment to avoid negating these benefits. Mobile communication equipment includes, but is not limited to, cellular phones, pagers, portable email devices, text messaging devices and portable two-way radios.

EMISSION LAW - UNITED STATES OF AMERICA



WARNING: Do not remove or alter the original equipment floor covering or insulation between it and the metal floor of the vehicle. The floor covering and insulation protect occupants of the vehicle from the engine and exhaust system heat and noise. On vehicles with no original equipment floor covering insulation, do not carry passengers in a manner that permits prolonged skin contact with the metal floor. Failure to follow these instructions may result in fire or personal injury.

U.S. federal laws and certain state laws prohibit removing or rendering inoperative emission control system components. Similar federal or provincial laws may apply in Canada. We do not approve of any vehicle modification without first determining applicable laws.



Tampering with emissions control systems including related sensors or the Diesel Exhaust Fluid system can result in reduced engine power and the illumination of the service engine soon light.

Tampering With a Noise Control System

Federal laws prohibit the following acts:

- Removal or rendering inoperative by any person other than for purposes of maintenance.
- Repair or replacement of any device or element of the design incorporated into a new vehicle for the purpose of noise control prior to its sale or delivery to the ultimate purchaser or while it is in use.
- The use of the vehicle after any person removes or renders inoperative any device or element of the design.

Customer Information

The U.S. Environmental Protection Agency may presume to constitute tampering as follows:

- Removal of hood blanket, fender apron absorbers, fender apron barriers, underbody noise shields or acoustically absorptive material.
- Tampering or rendering inoperative the engine speed governor, to allow engine speed to exceed manufacturer specifications.

If the engine does not start, runs rough, experiences a decrease in engine performance, experiences excess fuel consumption or produces excessive exhaust smoke, check for the following:

- A plugged or disconnected air inlet system hose.
- A plugged engine air filter element.
- Water in the fuel filter and water separator.
- A clogged fuel filter.
- Contaminated fuel.
- Air in the fuel system, due to loose connections.
- An open or pinched sensor hose.
- Incorrect engine oil level.

- Incorrect fuel for climatic conditions.
- Incorrect engine oil viscosity for climactic conditions.

Note: *Some vehicles have a lifetime fuel filter that is integrated with the fuel tank. Regular maintenance or replacement is not needed.*

Note: *If these checks do not help you correct the concern, have your vehicle checked as soon as possible.*

Noise Emissions Warranty, Prohibited Tampering Acts and Maintenance

On January 1, 1978, Federal regulation became effective governing the noise emission on trucks over 10,000 lb (4,536 kg) Gross Vehicle Weight Rating (GVWR). The preceding statements concerning prohibited tampering acts and maintenance, and the noise warranty found in the Warranty Guide, are applicable to complete chassis cabs over 10,000 lb (4,536 kg) GVWR.

EXPORT UNIQUE OPTIONS

For your particular global region, your vehicle may be equipped with features and options that are different from the features and options that are described in this Owner's Manual. A market unique supplement may be supplied that complements this book. By referring to the market unique supplement, if provided, you can properly identify those features, recommendations and specifications that are unique to your vehicle. This Owner's Manual is written primarily for the U.S. and Canadian markets. Features or equipment listed as standard may be different on units built for export. **Refer to this Owner's Manual for all other required information and warnings.**

WARRANTY INFORMATION

The following warranties may apply to your vehicle:

- New vehicle limited warranties.
- Emissions warranties, if applicable. (Note: Fully-electric vehicles are not eligible for emissions warranties.)
- Other warranties, if applicable.

Customer Information

Detailed warranty information specific to your vehicle can be found in the Warranty Guide at www.owner.ford.com.

The following California Warranty Statement, required by California regulations, applies to vehicles certified to California emissions standards and registered in a state that requires California emissions warranty. If applicable, additional California Emissions Warranties can be found in the Warranty Guide at www.owner.ford.com.

CALIFORNIA EMISSION CONTROL WARRANTY STATEMENT

YOUR WARRANTY RIGHTS AND OBLIGATIONS

The California Air Resources Board and Ford Motor Company are pleased to explain the emission control system warranty on your (year) vehicle. In California, new motor vehicles must be designated, built and equipped to meet the State's stringent anti-smog standards. Ford Motor Company must warrant the emission control system on your vehicle for the periods of time listed below provided there has been no abuse, neglect or improper maintenance of your vehicle.

Your emission control system may include parts such as the carburetor or fuel-injection system, the ignition system, catalytic converter and engine computer. Also included may be hoses, belts, connectors and other emission-related assemblies. Where a warrantable condition exists, Ford Motor Company will repair your vehicle at no cost to you including diagnosis, parts and labor.

MANUFACTURER'S WARRANTY COVERAGE:

(For 1990 and subsequent model passenger cars, light-duty trucks, and medium-duty vehicles.)

- For 3 years or 50,000 miles (whichever occurs first);

1) If your vehicle fails a Smog Check inspection, all necessary repairs and adjustments will be made by Ford Motor Company to ensure that your emission control system PERFORMANCE WARRANTY.

2) If any emission-related part on your vehicle is defective, the part will be repaired or replaced by Ford Motor Company. This is your short-term emission control system DEFECTS WARRANTY.

- For 7 years or 70,000 miles (whichever occurs first);

1) If an emission-related part listed in this warranty booklet specially noted with coverage for 7 years or 70,000 miles is defective, the part will be repaired or replaced by Ford Motor Company. This is your long-term emission control system DEFECTS WARRANTY.

OWNER'S WARRANTY RESPONSIBILITIES:

- As the vehicle owner, you are responsible for the performance of the required maintenance listed in your owner's manual. Ford Motor Company recommends that you retain all receipts covering maintenance on your vehicle, but Ford Motor Company cannot deny warranty solely for the lack of receipts or for your failure to ensure the performance of all scheduled maintenance.

- You are responsible for presenting your vehicle to a Ford or Lincoln dealer as soon as a problem exists. The warranty repairs should be completed in a reasonable amount of time, not to exceed 30 days.

- As the vehicle owner, you should also be aware that Ford Motor Company may deny you warranty coverage if your vehicle or a part has failed due to abuse, neglect, improper maintenance or unapproved modifications.

Customer Information

If you have any questions regarding your warranty rights and responsibilities, you should contact Ford Customer Service at 1-800-392-3673 or the California Air Resource Board at 4001 Iowa Avenue, Riverside, CA 92507.

New Vehicle Limited Warranty

Your vehicle comes with a New Vehicle Limited Warranty. The express warranties of the New Vehicle Limited Warranty are in substitution for and exclude all other liabilities of any kind whether arising under statute, in tort, by implication of law or otherwise including, to the full extent as may be allowed by law, liability for any other representations respecting the vehicle, statutory warranties or implied warranties or conditions as to its merchantability or fitness.

Download a free electronic copy or order one free printed copy of the most up-to-date Warranty Guide by visiting the Owner Manuals section of owner.ford.com (United States).

For Canada, visit ford.ca/warranty.

For Limo/Livery/Hearse vehicles: View and download your Warranty Guide by visiting the Warranty Information section of the Fleet website, fleet.ford.com/limo (United States only).

Appendices

ELECTROMAGNETIC COMPATIBILITY



WARNING: Do not place objects or mount equipment on or near the airbag cover, on the side of the front or rear seatbacks, or in areas that may come into contact with a deploying airbag. Failure to follow these instructions may increase the risk of personal injury in the event of a crash.



WARNING: Keep antenna and power cables at least 4 in (10 cm) from any electronic modules and airbags.

Note: We test and certify your vehicle to meet electromagnetic compatibility legislation. It is your responsibility to make sure that any equipment an authorized dealer installs on your vehicle complies with applicable local legislation and other requirements. Installation of some aftermarket electronic devices could degrade the performance of vehicle functions, which use radio frequency signals such as broadcast radio receiver, tire pressure monitoring system, push button start, **Bluetooth**[®] connectivity or satellite navigation.

Note: Any radio frequency transmitter equipment in your vehicle, such as, cellular telephones and amateur radio transmitters, must keep to the parameters in the following illustrations and table. We do not provide any other special provisions or conditions for installations or use.

Appendices

Car

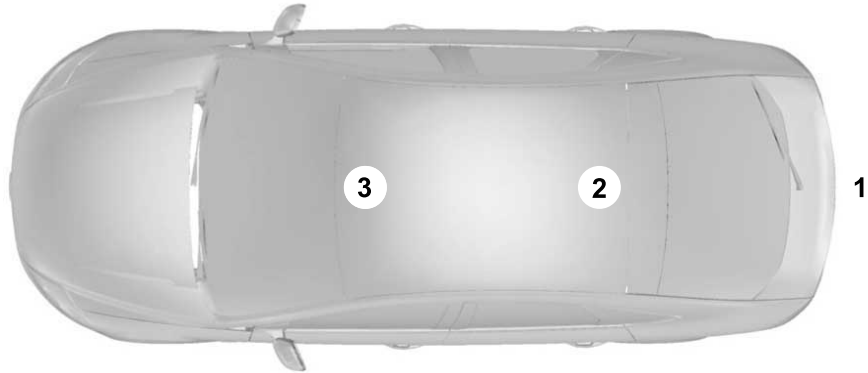

Appendices

Van

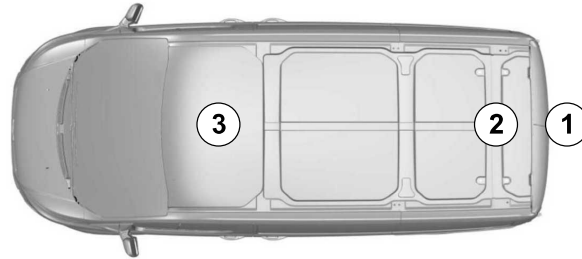

Appendices

Truck

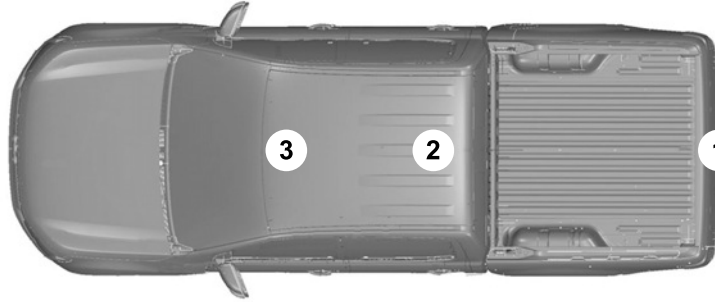

Frequency Band MHz	Maximum Output Power Watt (Peak RMS)	Antenna Positions
1-30	50	1
50-54	50	2, 3
68-88	50	2, 3
142-176	50	2, 3
380-512	50	2, 3
806-870	10	2, 3

Index

1		
12V Battery.....	407	
12V Battery Precautions.....	407	
Battery Management System		
Limitations.....	408	
Changing the 12V Battery.....	408	
How Does the Battery Management System		
Work.....	408	
Recycling and Disposing of the 12V		
Battery.....	409	
Resetting the Battery Sensor.....	409	
What Is the Battery Management		
System.....	408	
12V Battery – Troubleshooting.....	410	
12V Battery – Information Messages.....	410	
12V Battery – Warning Lamps.....	410	
3		
360 Degree Camera.....	251	
360 Degree Camera Settings.....	253	
360 Degree Camera Guide Lines.....	252	
360 Degree Camera Limitations.....	251	
360 Degree Camera Precautions.....	251	
360 Degree Camera Settings.....	253	
Switching the 360 Degree Camera On and		
Off.....	253	
Switching the 360 Degree Camera		
View.....	253	
4		
4WD		
See: Four-Wheel Drive.....	198	
9		
911 Assist.....	62	
A		
A/C		
See: Climate Control.....	129	
About This Publication.....	17	
ABS		
See: Brakes.....	212	
Accessing the Passive Key Backup		
Position.....	176	
Accessing the Trip Computer.....	126	
Accessories.....	486	
Adaptive Cruise Control.....	255	
Adaptive Cruise Control –		
Troubleshooting.....	270	
Lane Centering.....	263	
Lane Centering – Troubleshooting.....	266	
Predictive Speed Assist.....	267	
Predictive Speed Assist –		
Troubleshooting.....	269	
Adaptive Cruise Control Automatic		
Cancellation.....	259	
Adaptive Cruise Control Indicators.....	263	
Adaptive Cruise Control Limitations.....	256	
Adaptive Cruise Control Precautions.....	255	
Adaptive Cruise Control –		
Troubleshooting.....	270	
Adaptive Cruise Control – Information		
Messages.....	270	
Adjustable Pedals.....	98	
Adjusting the Exterior Mirrors.....	120	
Adjusting the Headlamps.....	411	
Adjusting the Instrument Panel Lighting		
Brightness.....	115	
Adjusting the Integrated Trailer Brake		
Controller Mode.....	344	
Adjusting the Luggage Compartment		
Divider.....	328	
Adjusting the Luggage Compartment Load		
Floor.....	327	
Adjusting the Pedals.....	98	
Adjusting the Seatbelt Height.....	48	
Adjusting the Seatbelts During		
Pregnancy.....	48	
Adjusting the Sound Settings.....	463	
Adjusting the Steering Wheel - Vehicles		
With: Manual Adjustable Steering		
Column.....	96	
Adjusting the Steering Wheel - Vehicles		
With: Power Adjustable Steering		
Column.....	96	
Adjusting the Volume.....	463	
Aid Mode.....	288	
How Does Aid Mode Work.....	288	
What Is Aid Mode.....	288	
Airbag Precautions.....	55	

Index

Airbags.....	53	Audio System.....	462	Automatic Engine Stop.....	176
Front Passenger Sensing System.....	57	AM/FM Radio.....	464	How Does Automatic Engine Stop Work.....	176
Air Conditioning		Digital Radio.....	464	Overriding Automatic Engine Stop.....	176
See: Climate Control.....	129	Satellite Radio.....	465	Switching Automatic Engine Stop On and Off.....	176
Air Conditioning System Refrigerant.....	134	Audio System Precautions.....	462	What Is Automatic Engine Stop.....	176
Alert and Aid Mode.....	288	Auto-Dimming Exterior Mirror.....	121	Automatic High Beam Control.....	110
How Does Alert and Aid Mode Work.....	289	What Is the Auto-Dimming Exterior Mirror.....	121	Automatic High Beam Control Indicators.....	112
What Is Alert and Aid Mode.....	288	Auto-Dimming Interior Mirror.....	119	Automatic High Beam Control Limitations.....	111
Alert Mode.....	288	Auto-Dimming Interior Mirror Limitations.....	119	Automatic High Beam Control Precautions.....	111
How Does Alert Mode Work.....	288	What Is the Auto-Dimming Interior Mirror.....	119	Automatic High Beam Control Requirements.....	111
What Is Alert Mode.....	288	Auto Hold.....	224	How Does Automatic High Beam Control Work.....	110
Alexa Built-In.....	472	Auto Hold Indicators.....	224	Overriding Automatic High Beam Control.....	112
AM/FM Radio.....	464	Autolamps.....	106	Switching Automatic High Beam Control On and Off.....	112
AM/FM Radio Limitations.....	464	Autolamp Settings.....	106	Automatic High Beam Control – Troubleshooting.....	113
Selecting an AM/FM Radio Station.....	464	What Are Autolamps.....	106	Automatic High Beam Control – Information Messages.....	113
Ambient Lighting.....	115	Autolock.....	74	Automatic Locking Mode.....	47
Adjusting Ambient Lighting.....	115	Autolock Requirements.....	74	Disengaging Automatic Locking Mode.....	48
Switching Ambient Lighting On and Off.....	115	Switching Autolock On and Off.....	74	Engaging Automatic Locking Mode.....	47
Anti-Lock Braking System.....	212	What Is Autolock.....	74	What Is Automatic Locking Mode.....	47
Anti-Lock Braking System Limitations.....	212	Automatically Releasing the Electric Parking Brake.....	217	When to Use Automatic Locking Mode.....	47
Anti-Theft Alarm System.....	90	Automatic Crash Shutoff.....	378	Automatic Return to Park (P).....	195
Arming the Anti-Theft Alarm System.....	90	Automatic Crash Shutoff Precautions.....	378		
Disarming the Anti-Theft Alarm System.....	90	Re-Enabling Your Vehicle.....	378		
How Does the Anti-Theft Alarm System Work.....	90	What Is Automatic Crash Shutoff.....	378		
What Is the Anti-Theft Alarm System.....	90	Automatic Emergency Braking.....	313		
What Is the Perimeter Alarm.....	90	Switching Automatic Emergency Braking On and Off.....	313		
Appendices.....	567	What Is Automatic Emergency Braking.....	313		
Applying the Electric Parking Brake.....	216				
Applying the Electric Parking Brake in an Emergency.....	216				
Apps.....	470				

Index

Automatic Transmission Audible Warnings.....	196
Automatic Transmission.....	192
Automatic Transmission Positions.....	192
Automatic Transmission Fluid Capacity and Specification.....	196
Automatic Transmission Positions.....	192
Automatic Transmission Position Indicators.....	193
Automatic Transmission Precautions.....	192
Drive (D).....	193
Manual (M).....	193
Neutral (N).....	193
Park (P).....	192
Reverse (R).....	193
Shifting Your Vehicle Into Gear.....	192
Auto Mode.....	131
Auto Mode Indicators.....	131
Switching Auto Mode On and Off.....	131
Switching Dual Mode On and Off.....	133
Auto-Start-Stop.....	181
Auto-Start-Stop – Troubleshooting.....	182
Auto-Start-Stop Indicators.....	181
Auto-Start-Stop Precautions.....	181
Auto-Start-Stop – Troubleshooting.....	182
Auto-Start-Stop – Frequently Asked Questions.....	183
Auto-Start-Stop – Information Messages.....	182
Autounlock.....	74
Autounlock Requirements.....	74
Switching Autounlock On and Off.....	74
What Is Autounlock.....	74
Autowipers.....	99
Adjusting the Sensitivity of the Rain Sensor.....	100
Autowipers Settings.....	99
What Are Autowipers.....	99
B	
Blind Spot Assist.....	290
Blind Spot Assist Limitations.....	290
How Does Blind Spot Assist Work.....	290
What Is Blind Spot Assist.....	290
Blind Spot Assist with Trailer Coverage.....	290
Blind Spot Assist with Trailer Coverage Indicators.....	292
Blind Spot Assist with Trailer Coverage Limitations.....	291
How Does Blind Spot Assist with Trailer Coverage Work.....	291
What Is Blind Spot Assist with Trailer Coverage.....	290
Blind Spot Information System.....	296
Blind Spot Information System – Troubleshooting.....	300
Blind Spot Information System With Trailer Coverage.....	297
Blind Spot Information System With Trailer Coverage Limitations.....	298
Selecting a Trailer.....	298
Setting a Trailer Length.....	298
What Is Blind Spot Information System with Trailer Coverage.....	297
BlueCruise Alerts.....	274
BlueCruise Automatic Cancellation.....	274
BlueCruise.....	271
BlueCruise – Troubleshooting.....	278
In-Lane Repositioning.....	277
Lane Change Assist.....	276
Lane Change Assist – Troubleshooting.....	277
BlueCruise Indicators.....	275
BlueCruise Limitations.....	273
BlueCruise Precautions.....	271
BlueCruise Requirements.....	272
BlueCruise Settings.....	273
BlueCruise – Troubleshooting.....	278
BlueCruise – Information Messages.....	278
Bluetooth®.....	479
Blind Spot Information System Precautions.....	296
Blind Spot Information System Requirements.....	297
Blind Spot Information System – Troubleshooting.....	300
Blind Spot Information System – Information Messages.....	300
Blind Spot Information System With Trailer Coverage.....	297
Blind Spot Information System With Trailer Coverage Limitations.....	298
Selecting a Trailer.....	298
Setting a Trailer Length.....	298
What Is Blind Spot Information System with Trailer Coverage.....	297

Index

Bonnet Lock			
See: Opening and Closing the Hood.....	396		
Booster Seats.....	41		
Brake Fluid Specification.....	213		
Brake Over Accelerator.....	212		
Brake Precautions.....	212		
Brakes.....	212		
Anti-Lock Braking System.....	212		
Brakes – Troubleshooting.....	214		
Brakes – Troubleshooting.....	214		
Brakes – Frequently Asked Questions.....	215		
Brakes – Warning Lamps.....	214		
Breaking-In.....	370		
C			
Calculating Payload.....	322		
Calculating the Load Limit.....	323		
Canceling the Set Speed.....	231		
Catalytic Converter.....	190		
Catalytic Converter – Troubleshooting.....	190		
Catalytic Converter Precautions.....	190		
Catalytic Converter – Troubleshooting.....	190		
Catalytic Converter – Warning Lamps.....	190		
Center Console.....	171		
Opening the Center Console.....	171		
Center Display.....	469		
Center Display Overview.....	469		
Changing a Flat Tire.....	450		
Changing a Road Wheel.....	450		
Changing the Fuel Filter.....	407		
Changing the Radio Station.....	468		
Changing the Remote Control Battery.....	65		
Charging a Device.....	164		
Charging a Wireless Device.....	169		
Checking the Brake Fluid.....	212		
Checking the Seatbelts.....	50		
Checking the Tire Pressures.....	437		
Checking the Wiper Blades.....	100		
Children and Airbags.....	56		
Child Restraint Anchor Points.....	34		
Locating the Child Restraint Lower Anchor Points.....	34		
Locating the Child Restraint Top Tether Anchor Points.....	35		
What Are the Child Restraint Anchor Points.....	34		
Child Restraints.....	35		
Child Restraint Position Information.....	35		
Child Restraints Recommendation.....	37		
Child Safety.....	33		
Child Restraint Anchor Points.....	34		
Child Restraints.....	35		
Installing Child Restraints.....	38		
Child Safety Locks.....	44		
Child Safety Precautions.....	33		
Cleaning Products.....	417		
Cleaning the Exterior.....	418		
Cleaning Camera Lenses and Sensors.....	419		
Cleaning Headlamps and Rear Lamps.....	418		
Cleaning Stripes or Graphics.....	419		
Cleaning the Engine Compartment.....	418		
Cleaning the Exterior Precautions.....	418		
Cleaning the Underbody.....	419		
Cleaning Wheels.....	418		
Cleaning Windows and Wiper Blades.....	418		
Cleaning the Interior.....	419		
Cleaning Carpets and Floor Mats.....	421		
Cleaning Displays and Screens.....	420		
Cleaning Fabric.....	420		
Cleaning Glass Roof Tracks.....	421		
Cleaning Leather.....	420		
Cleaning Plastic.....	420		
Cleaning Seatbelts.....	421		
Cleaning the Instrument Panel.....	419		
Cleaning Vinyl.....	421		
Climate Control.....	129		
Auto Mode.....	131		
Climate Control Hints.....	133		
Connected Navigation.....	482		
Connected Vehicle.....	458		
Connected Vehicle – Troubleshooting.....	459		
Connecting the Vehicle to a Mobile Network.....	458		
Connected Vehicle Data.....	26		
Connected Vehicle Limitations.....	458		
Connected Vehicle Requirements.....	458		
Connected Vehicle Settings.....	459		
Connected Vehicle – Troubleshooting.....	459		
Connected Vehicle – Frequently Asked Questions.....	459		
Connecting a Bluetooth® Device.....	479		
Connecting a Trailer.....	332		
Connecting a Trailer – Troubleshooting.....	334		

Index

Hitches.....	330	Creating a Personal Profile.....	480	Directing the Flow of Air.....	131
Connecting a Trailer Precautions.....	330	Cross Traffic Alert.....	304	Disposing of Airbags.....	61
Connecting a Trailer – Troubleshooting.....	334	Cross Traffic Alert – Troubleshooting.....	307	Doors and Locks Audible Warnings.....	75
Connecting a Trailer – Information Messages.....	334	Cross Traffic Alert Indicators.....	306	Doors and Locks.....	73
Connecting the Vehicle to a Mobile Network.....	458	Cross Traffic Alert Limitations.....	305	Autolock.....	74
Connecting FordPass to the Modem.....	458	Cross Traffic Alert Precautions.....	304	Autounlock.....	74
Enabling and Disabling the Modem.....	458	Cross Traffic Alert – Troubleshooting.....	307	Doors and Locks – Troubleshooting.....	75
What Is the Modem.....	458	Cross Traffic Alert – Information Messages.....	307	Mislock.....	74
Connecting the Vehicle to a Wi-Fi Network.....	458	Customer Information.....	498	Operating the Doors From Inside Your Vehicle.....	73
Connecting Your Phone.....	475	Radio Frequency Certification Labels.....	501	Operating the Doors From Outside Your Vehicle.....	73
Contacting Us.....	15	Customizing the Instrument Panel Display.....	470	Doors and Locks – Troubleshooting.....	75
Controls.....	470	D		Doors and Locks – Information Messages.....	75
Coolant.....	402	Data Privacy.....	24	Doors and Locks – Warning Lamps.....	75
Adding Coolant.....	403	Department of Transportation Uniform Tire Quality Grades.....	425	Drive Belt Routing Overview.....	407
Changing the Coolant.....	404	Digital Radio.....	464	Drive Mode Control.....	280
Checking the Coolant Level.....	402	Digital Radio Indicators.....	465	Drive Mode Control – Troubleshooting.....	283
Coolant – Information Messages.....	406	Digital Radio Limitations.....	465	Drive Modes.....	281
Coolant – Warning Lamps.....	406	How Does Digital Radio Work.....	464	Drive Mode Control – Troubleshooting.....	283
Cooling System Capacity and Specification.....	405	Switching Digital Radio Reception On and Off.....	465	Drive Mode Control – Frequently Asked Questions.....	285
Managing the Coolant Temperature.....	404	What Is Digital Radio.....	464	Drive Mode Control – Information Messages.....	284
Crash and Breakdown Information.....	374	Dinghy Tow See: Recreationally Towing Your Vehicle – 4x2.....	384	Drive Mode Control – Warning Lamps.....	283
Automatic Crash Shutoff.....	378	See: Recreationally Towing Your Vehicle – 4x4.....	382	Drive Modes.....	281
Fail-Safe Cooling.....	380			Eco.....	281
Jump Starting the Vehicle.....	375			Normal.....	281
Post-Crash Alert System.....	377			Off-Road.....	281
Recovery Towing.....	379			Rock Crawl.....	282
Crash Sensors and Airbag Indicator.....	60				

Index

Slippery.....	282	Electric Parking Brake – Warning Lamps.....	217	Engine Coolant Temperature Gauge.....	125
Sport.....	283	Electric Power Steering.....	240	Engine Oil.....	398
Tow/Haul.....	283	Electric Power Steering Precautions.....	240	Adding Engine Oil.....	398
Driver Alert.....	319	How Does Electric Power Steering		Checking the Engine Oil Level.....	398
Driver Alert – Troubleshooting.....	320	Work.....	240	Engine Oil Capacity and Specification.....	399
Driver Alert Indicators.....	320	Electromagnetic Compatibility.....	567	Engine Oil Dipstick Overview.....	398
Driver Alert Limitations.....	319	Electronic Locking Differential.....	209	Intelligent Oil Life Monitor.....	399
Driver Alert Precautions.....	319	Electronic Locking Differential –		Resetting the Intelligent Oil Life	
Driver Alert – Troubleshooting.....	320	Troubleshooting.....	211	Monitor.....	399
Driver Alert – Information Messages.....	320	Electronic Locking Differential		Engine Specifications.....	415
Driving Economically.....	370	Indicators.....	211	Environment.....	28
Driving Hints.....	370	Electronic Locking Differential		Evasive Steering Assist.....	313
Driving in Cold Weather.....	370	Precautions.....	209	Evasive Steering Assist Limitations.....	313
Driving In Sand.....	371	Electronic Locking Differential –		Switching Evasive Steering Assist On and	
Driving on Hilly or Sloping Terrain.....	371	Troubleshooting.....	211	Off.....	313
Driving Through Mud and Water.....	371	Electronic Locking Differential – Information		What Is Evasive Steering Assist.....	313
Driving Through Shallow Water.....	372	Messages.....	211	Event Data.....	25
Drowsiness Monitor		Emergency Call Limitations.....	63	Exit Warning.....	301
See: Driver Alert.....	319	Emergency Call Requirements.....	62	Exit Warning – Troubleshooting.....	303
E		Emergency Call System Data.....	27	Exit Warning Indicators.....	302
Easy Entry and Exit.....	81	Emergency Towing.....	384	Exit Warning Limitations.....	302
Electric Parking Brake Audible		Emission Law - United States of		Exit Warning Precautions.....	301
Warning.....	217	America.....	563	Exit Warning – Troubleshooting.....	303
Electric Parking Brake.....	216	Enabling or Disabling Personal		Exit Warning – Information Messages.....	303
Electric Parking Brake –		Profiles.....	480	Expanse Display	
Troubleshooting.....	217	Engine Air Filter.....	401	See: Customizing the Instrument Panel	
Electric Parking Brake –		Changing the Engine Air Filter.....	401	Display.....	470
Troubleshooting.....	217	Engine Block Heater.....	174	Export Unique Options.....	564
Electric Parking Brake – Information		Engine Block Heater Precautions.....	174	Exterior Bulbs.....	413
Messages.....	218	How Does the Engine Block Heater		Changing a License Plate Lamp Bulb.....	414
		Work.....	175	Exterior Bulb Specification Chart.....	413
		Using the Engine Block Heater.....	175		

Index

Exterior Lamps.....	107	How Does Fail-Safe Cooling Work.....	380	Two-Wheel Drive High.....	200
Exterior Lamps On Audible Warning.....	109	What Is Fail-Safe Cooling.....	380	Four-Wheel Drive Precautions.....	198
Switching the Daytime Running Lamps On and Off.....	107	Fastening and Unfastening the Seatbelts.....	46	Four-Wheel Drive – Troubleshooting.....	202
Switching the Rear Floodlamps On and Off.....	108	Flat Tire.....		Four-Wheel Drive – Information Messages.....	203
Using the Front Fog Lamps.....	108	See: Changing a Flat Tire.....	450	Four-Wheel Drive – Warning Lamps.....	202
Using the Off-Road Driving Lamps.....	108	Flat Tow.....		Four Wheels Down Tow.....	
Using the Turn Signal Lamps.....	107	See: Recreationally Towing Your Vehicle - 4x2.....	384	See: Recreationally Towing Your Vehicle - 4x2.....	384
Exterior Lighting Control.....	105	See: Recreationally Towing Your Vehicle - 4x4.....	382	See: Recreationally Towing Your Vehicle - 4x4.....	382
Exterior Lighting.....	105	Floor Mats.....	372	Front Axle Fluid Capacity and Specification.....	205
Autolamps.....	106	Folding the Exterior Mirrors - Vehicles With: Manual Folding Mirrors.....	120	Front Axle.....	205
Automatic High Beam Control.....	110	Folding the Exterior Mirrors - Vehicles With: Power Folding Mirrors.....	121	Front Parking Aid.....	244
Automatic High Beam Control – Troubleshooting.....	113	Foot Pedals.....		Front Parking Aid Audible Warnings.....	245
Exterior Lamps.....	107	See: Adjusting the Pedals.....	98	Front Parking Aid Limitations.....	245
Exterior Zone Lighting.....	109	Ford Protect.....	488	Locating the Front Parking Aid Sensors.....	245
Headlamps.....	105	Forward Collision Warning.....	312	What is the Front Parking Aid.....	244
Headlamps – Troubleshooting.....	106	Adjusting the Sensitivity of Forward Collision Warning.....	312	Front Passenger Sensing System.....	57
Exterior Mirrors.....	120	What is Forward Collision Warning.....	312	Front Passenger Sensing System Indicators.....	59
Auto-Dimming Exterior Mirror.....	121	Four-Wheel Drive.....	198	Front Passenger Sensing System Precautions.....	59
Exterior Overview.....	31	Four-Wheel Drive Modes.....	200	How Does the Front Passenger Sensing System Work.....	57
Exterior Zone Lighting.....	109	Four-Wheel Drive – Troubleshooting.....	202	What Is the Front Passenger Sensing System.....	57
Using the Exterior Zone Lighting.....	109	Four-Wheel Drive Indicators.....	201	Front Seat Precautions.....	138
What Is Exterior Zone Lighting.....	109	Four-Wheel Drive Limitations.....	199	Front Seats.....	138
F		Four-Wheel Drive Modes.....	200	Heated Seats.....	145
Fail-Safe Cooling.....	380	Four-Wheel Drive Auto.....	200	Manual Seats.....	139
Driving When Fail-Safe Mode Is Activated.....	381	Four-Wheel Drive High.....	201		
Fail-Safe Cooling Indicators.....	381	Four-Wheel Drive Low.....	201		

Index

Massage Seats.....	144
Power Seats.....	141
Ventilated Seats.....	146
Fuel and Refueling.....	184
Fuel and Refueling – Troubleshooting.....	189
Fuel Quality.....	184
Refueling.....	187
Running Out of Fuel.....	185
Fuel and Refueling Precautions.....	184
Fuel and Refueling – Troubleshooting.....	189
Fuel and Refueling – Information Messages.....	189
Fuel and Refueling – Warning Lamps.....	189
Fuel Gauge.....	125
Fuel Gauge Limitations.....	125
Locating the Fuel Filler Door.....	125
What Is Distance to Empty.....	125
What Is the Fuel Gauge.....	125
What Is the Low Fuel Reminder.....	125
Fuel Quality.....	184
Selecting the Correct Fuel.....	184
Fuel Tank Capacity.....	188
Fuse Precautions.....	385
Fuses.....	385
Fuses – Troubleshooting.....	395
Interior Fuse Box.....	391
Under Hood Fuse Box.....	385
Fuses – Troubleshooting.....	395
Fuses – Frequently Asked Questions.....	395

G

Garage Door Opener.....	160
Garage Door Opener Introduction.....	160
Garage Door Opener Precautions and Frequencies.....	160
General Maintenance Information.....	493
Glass Roof Bounce-Back.....	123
Overriding Glass Roof Bounce-Back.....	123
What Is Glass Roof Bounce-Back.....	123
Glass Roof.....	122
Glass Roof Bounce-Back.....	123
Global Opening and Closing.....	116
Switching Global Closing On and Off.....	117
Switching Global Opening On and Off.....	117
Using Global Closing.....	117
Using Global Opening.....	117
What Is Global Opening and Closing.....	116
Glossary of Tire Terminology.....	431
Glove Compartment.....	171
Opening the Glove Compartment.....	171
Google Assistant.....	473

H

Headlamp Adjusting See: Adjusting the Headlamps.....	411
Headlamps.....	105
Headlamp Indicators.....	105
Switching Headlamp Exit Delay On and Off.....	105
Using the High Beam Headlamps.....	105

Headlamps – Troubleshooting.....	106
Headlamps – Frequently Asked Questions.....	106
Heated Seats.....	145
Heated Seat Precautions.....	145
Switching the Heated Seats On and Off.....	145
Heating See: Climate Control.....	129
Hill Descent Control.....	238
Hill Descent Control – Troubleshooting.....	239
Hill Descent Control Indicator.....	238
Hill Descent Control Precautions.....	238
Hill Descent Control – Troubleshooting.....	239
Hill Descent Control – Information Messages.....	239
Hill Start Assist.....	223
Hill Start Assist – Troubleshooting.....	223
Hill Start Assist Precautions.....	223
Hill Start Assist – Troubleshooting.....	223
Hill Start Assist – Information Messages.....	223
Hitches.....	330
Hooking Up a Trailer Using a Weight-Distributing Hitch.....	331
Installing a Hitch.....	330
Hood Lock See: Opening and Closing the Hood.....	396
Horn.....	97
How Does 911 Assist Work.....	62
How Does Adaptive Cruise Control With Stop and Go Work.....	255

Index

How Does Auto Hold Work.....	224
How Does Blind Spot Information System Work.....	296
How Does BlueCruise Work.....	271
How Does Cross Traffic Alert Work.....	304
How Does Drive Mode Control Work.....	280
How Does Driver Alert Work.....	319
How Does Easy Entry and Exit Work.....	81
How Does Exit Warning Work.....	301
How Does Four-Wheel Drive Work.....	198
How Does Hill Descent Control Work.....	238
How Does Hill Start Assist Work.....	223
How Does Pre-Collision Assist Work.....	308
How Does Reverse Brake Assist Work.....	219
How Does Speed Sign Recognition Work.....	316
How Does Stability Control Work.....	227
How Does the 360 Degree Camera Work.....	251
How Does the Electronic Locking Differential Work.....	209
How Does the Lane Keeping System Work.....	286
How Does the Personal Safety System Work.....	52
How Does the Rear Occupant Alert System Work.....	157
How Does the Safety Canopy™ Work.....	54
How Does Traction Control Work.....	225
How Does Trailer Backup Assistance Work.....	352
How Does Trailer Hitching Assistance Work.....	348
How Does Trailer Reverse Guidance Work.....	362
How Does Trailer Sway Control Work.....	347
How Do Personal Profiles Work.....	480
How Do the Front Airbags Work.....	53
How Do the Side Airbags Work.....	53
I	
Icon Glossary	
See: Symbols Glossary.....	19
Icons	
See: Symbols Glossary.....	19
Identifying Fuse Types.....	395
Identifying the Climate Control Unit.....	129
Identifying the Rear Passenger Audio Controls.....	468
Identifying the Rear Passenger Climate Control Unit.....	135
Inflating the Tires.....	437
Information on the Tire Sidewall.....	426
In-Lane Repositioning.....	277
How Does In-Lane Repositioning Work.....	277
In-Lane Repositioning Indicators.....	278
Switching In-Lane Repositioning On and Off.....	278
Inspecting the Tire for Damage.....	439
Inspecting the Tire for Wear.....	438
Inspecting the Wheel Valve Stems.....	443
Installing and Removing the Luggage Compartment Cargo Net.....	326
Installing Child Restraints.....	38
Combining the Seatbelt and Lower Anchors for Attaching Child Restraints.....	41
Installing a Child Restraint in a Center Seat.....	40
Using Lower Anchors and Tethers for Children.....	40
Using Seatbelts.....	38
Using Tether Straps.....	41
Instrument Cluster.....	124
Fuel Gauge.....	125
Instrument Cluster Overview.....	124
Integrated Trailer Brake Controller.....	342
Integrated Trailer Brake Controller – Troubleshooting.....	345
Integrated Trailer Brake Controller Precautions.....	342
Integrated Trailer Brake Controller – Troubleshooting.....	345
Integrated Trailer Brake Controller – Frequently Asked Questions.....	346
Integrated Trailer Brake Controller – Information Messages.....	345
Interior Air Quality.....	137
Interior Bulbs.....	414
Interior Bulb Specification Chart.....	414
Interior Fuse Box.....	391
Accessing the Interior Fuse Box.....	391
Identifying the Fuses in the Interior Fuse Box.....	392

Index

Locating the Interior Fuse Box.....	391	Keyless Entry Keypad Limitations.....	78	Lane Centering Limitations.....	264
Interior Lamp Function.....	114	Keyless Entry Keypad Master Access		Lane Centering Manual Cancellation.....	265
Switching the Interior Lamp Function On and		Code.....	78	Lane Centering Precautions.....	263
Off.....	114	Keyless Entry Keypad Personal Access		Lane Centering Requirements.....	263
What Is the Interior Lamp Function.....	114	Codes.....	79	Switching Lane Centering On and Off.....	264
Interior Lighting.....	114	Keyless Entry Keypad –		Lane Centering – Troubleshooting.....	266
Ambient Lighting.....	115	Troubleshooting.....	80	Lane Centering – Information	
Interior Lamp Function.....	114	Keyless Entry Keypad – Frequently Asked		Messages.....	266
Interior Lighting – Troubleshooting.....	115	Questions.....	80	Lane Change Assist.....	276
Interior Lighting – Troubleshooting.....	115	Keyless Entry Limitations.....	76	How Does Lane Change Assist Work.....	276
Interior Lighting – Frequently Asked		Keyless Entry Settings.....	76	Lane Change Assist Cancellation.....	276
Questions.....	115	Keyless Entry – Troubleshooting.....	77	Lane Change Assist Limitations.....	276
Interior Mirror.....	119	Keyless Entry – Frequently Asked		Switching Lane Change Assist On and	
Auto-Dimming Interior Mirror.....	119	Questions.....	77	Off.....	276
Interior Mirror Precautions.....	119	Keys and Remote Controls Audible		Lane Change Assist –	
Interior Overview.....	29	Warnings.....	67	Troubleshooting.....	277
Introduction.....	17	Keys and Remote Controls.....	64	Lane Change Assist – Information	
J		Keys and Remote Controls –		Messages.....	277
Jump Starting the Vehicle.....	375	Troubleshooting.....	68	Lane Keeping System Indicators.....	289
Jump Starting Precautions.....	375	Keys and Remote Controls –		Lane Keeping System.....	286
Jump Starting the Vehicle.....	376	Troubleshooting.....	68	Aid Mode.....	288
Preparing the Vehicle.....	376	Keys and Remote Controls – Information		Alert and Aid Mode.....	288
		Messages.....	68	Alert Mode.....	288
K		L		Blind Spot Assist.....	290
Keyless Entry.....	76	Lane Centering.....	263	Blind Spot Assist with Trailer Coverage.....	290
Keyless Entry – Troubleshooting.....	77	How Does Lane Centering Work.....	263	Lane Keeping System –	
Keyless Entry Keypad.....	78	Lane Centering Alerts.....	265	Troubleshooting.....	294
Keyless Entry Keypad –		Lane Centering Automatic		Lane Keeping System Limitations.....	286
Troubleshooting.....	80	Cancellation.....	265	Lane Keeping System Precautions.....	286
		Lane Centering Indicators.....	266	Lane Keeping System Settings.....	287

Index

Lane Keeping System – Troubleshooting.....294	Locating the Tire label.....425	Manually Releasing the Electric Parking Brake.....216
Lane Keeping System – Frequently Asked Questions.....295	Locating the USB Ports.....164	Manually Shifting Gears.....193
Lane Keeping System – Information Messages.....294	Locating the Wireless Accessory Charger.....169	Manual Seats.....139
Launching or Retrieving a Boat or Personal Watercraft.....337	Locating Your Vehicle.....65	Accessing the Third Row Seats.....150
Liftgate Settings.....86	Locking the Rear Passenger Audio Controls.....463	Adjusting the Head Restraint.....139
Linking or Unlinking a Personal Profile to a Device.....481	Locking the Rear Passenger Climate Controls.....131	Adjusting the Seat Backrest.....140
Linking or Unlinking a Personal Profile to a Remote Control.....481	Locking the Rear Window Controls.....118	Folding the Seat Backrest.....149
Load Carrying.....321	Luggage Compartment Anchor Points.....329	Head Restraint Components.....139
Roof Rack.....324	Luggage Compartment Anchor Point Precautions.....329	Installing the Head Restraint.....140
Load Carrying Precautions.....321	Luggage Compartment.....326	Moving the Seat Backward and Forward.....140
Loading Your Trailer.....336	Luggage Compartment Anchor Points.....329	Removing the Head Restraint.....140
Locating the 360 Degree Cameras.....251	Luggage Compartment Precautions.....326	Unfolding the Seats.....150
Locating the Blind Spot Information System Sensors.....297	M	Massage Seats.....144
Locating the Brake Fluid Reservoir.....212	Maintenance.....396	Adjusting the Massage Seat Settings.....145
Locating the Cross Traffic Alert Sensors.....306	12V Battery.....407	Massage Seat Limitations.....144
Locating the Exit Warning Sensors.....303	12V Battery – Troubleshooting.....410	Media Control Buttons.....462
Locating the Fuel Filler Funnel.....185	Coolant.....402	Mislock.....74
Locating the Keyless Entry Keypad.....78	Engine Air Filter.....401	Mislock Limitations.....74
Locating the Power Outlets.....166	Engine Oil.....398	Switching Mislock On and Off.....74
Locating the Pre-Collision Assist Sensors.....312	Exterior Bulbs.....413	What Is Mislock.....74
Locating the Rear View Camera.....248	Interior Bulbs.....414	Mobile Communications Equipment.....563
Locating the Safety Compliance Certification Labels.....321	Maintenance Precautions.....396	Mobile Device Data.....27
	Making and Receiving a Phone Call.....476	Moonroof
	Manually Dimming the Interior Mirror.....119	See: Glass Roof.....122
		Motorcraft Parts.....416

N

Navigation.....482

Index

Neutral Towing

See: Recreationally Towing Your Vehicle -
4x2.....384

See: Recreationally Towing Your Vehicle -
4x4.....382

Neutral Tow

See: Recreationally Towing Your Vehicle -
4x2.....384

See: Recreationally Towing Your Vehicle -
4x4.....382

O

Opening and Closing the Glass Roof.....122

Opening and Closing the Hood.....396

Opening and Closing the Liftgate.....84

Opening and Closing the Splitgate.....82

Opening and Closing the Sunshade.....122

Opening and Closing the Tailgate.....87

Opening and Closing the Windows.....116

Opening the Open on Approach
Splitgate.....83

Open on Approach Settings.....84

Operating the Doors From Inside Your

Vehicle.....73

Opening the Doors From Inside Your

Vehicle.....73

Unlocking and Locking the Doors Using the

Central Locking.....73

Operating the Doors From Outside Your

Vehicle.....73

Unlocking and Locking the Doors Using the

Key Blade.....73

Unlocking and Locking the Doors Using the

Remote Control.....73

OTA

See: Software Update Settings.....483

See: Vehicle Software Updates.....483

Overhead Storage.....171

Opening the Overhead Storage

Compartment.....171

Overriding Reverse Brake Assist.....220

Overriding the Set Speed.....262

Over the air

See: Software Update Settings.....483

Over-the-air

See: Software Update Settings.....483

See: Vehicle Software Updates.....483

See: Vehicle Software Updates.....483

P

Panorama Roof

See: Glass Roof.....122

Panoramic Display

See: Customizing the Instrument Panel

Display.....470

Panoramic Roof

See: Glass Roof.....122

Parking Aid Indicators.....246

Parking Aid Precautions.....243

Parking Aids.....243

Front Parking Aid.....244

Parking Aids – Troubleshooting.....247

Rear Parking Aid.....244

Parking Aids – Troubleshooting.....247

Parking Aids – Information Messages.....247

Passive Anti-Theft System.....90

How Does the Passive Anti-Theft System

Work.....90

What Is the Passive Anti-Theft System.....90

Perchlorate.....562

Performing a System Reset.....485

Personal Profiles.....480

Personal Safety System Components.....52

Personal Safety System™.....52

Phone as a Key Limitations.....69

Phone as a Key.....69

Phone as a Key – Troubleshooting.....71

Phone as a Key – Troubleshooting.....71

Phone as a Key – Frequently Asked

Questions.....71

Phone Menu.....475

Phone.....475

Phone Precautions.....475

Playing and Pausing the Audio

Source.....468

Playing Media Using Bluetooth®.....479

Playing Media Using the USB Port.....164

Post-Collision Braking.....378

Post-Crash Alert System.....377

How Does the Post-Crash Alert System

Work.....378

Index

Post-Crash Alert System Limitations.....	378
Switching the Post-Crash Alert System	
Off.....	378
What Is the Post-Crash Alert System.....	377
Power Outlet Indicators.....	167
Power Outlet Limitations.....	166
Power Outlet.....	166
Power Outlet Precautions.....	166
Power Running Board Precautions.....	93
Power Running Board Settings.....	93
Power Running Boards.....	93
Power Running Boards –	
Troubleshooting.....	94
Power Running Boards –	
Troubleshooting.....	94
Power Running Boards – Frequently Asked	
Questions.....	94
Power Seats.....	141
Adjusting the Head Restraint.....	141
Adjusting the Lumbar Support.....	144
Adjusting the Seat Backrest.....	144
Adjusting the Seat Cushion.....	144
Adjusting the Seat Height.....	144
Folding the Seat Backrest.....	154
Head Restraint Components.....	141
Installing and Removing a Device.....	142
Installing the Head Restraint.....	142
Moving the Seat Backward and	
Forward.....	143
Removing the Head Restraint.....	142
Unfolding the Seat Backrest.....	155
Power-Up	
See: Software Update Settings.....	483
See: Vehicle Software Updates.....	483
Pre-Collision Assist Limitations.....	309
Pre-Collision Assist Precautions.....	308
Pre-Collision Assist.....	308
Automatic Emergency Braking.....	313
Evasive Steering Assist.....	313
Forward Collision Warning.....	312
Pre-Collision Assist – Troubleshooting.....	314
Pre-Collision Assist –	
Troubleshooting.....	314
Pre-Collision Assist – Frequently Asked	
Questions.....	315
Pre-Collision Assist – Information	
Messages.....	314
Pre-Collision Assist – Warning Lamps.....	314
Predictive Speed Assist.....	267
Adjusting the Set Speed Tolerance.....	268
How Does Predictive Speed Assist	
Work.....	267
Predictive Speed Assist Alerts.....	268
Predictive Speed Assist Indicators.....	268
Predictive Speed Assist Limitations.....	268
Predictive Speed Assist Precautions.....	267
Switching Predictive Speed Assist Mode On	
and Off.....	268
Predictive Speed Assist –	
Troubleshooting.....	269
Predictive Speed Assist – Information	
Messages.....	269
Preparing Your Vehicle for Storage.....	423
Programming the Garage Door	
Opener.....	161
Programming the Remote Control.....	66
Programming Your Phone.....	69
Properly Adjusting the Driver and Front	
Passenger Seats.....	56
Protecting the Environment.....	28
Puncture	
See: Changing a Flat Tire.....	450
Push Button Ignition Switch.....	173
R	
Radio Frequency Certification Labels.....	501
Blind Spot Information System Sensors.....	501
Body Control Module.....	511
Cruise Control Module.....	514
Operating System.....	521
Passive Key.....	524
Radio Transceiver Module.....	531
Telematics Control Unit.....	536
Tire Pressure Monitoring System	
Sensors.....	540
Wireless Accessory Charging Module.....	552
Rear Auto Mode.....	136
Switching Rear Auto Mode On and Off.....	136
Rear Axle Fluid Capacity and	
Specification.....	206
Rear Axle.....	206
Rear Occupant Alert System Audible	
Warnings.....	159

Index

Rear Occupant Alert System Indicators.....	158	Zooming the Rear View Camera In and Out.....	249	Resetting the Stopping Position - Vehicles With: Power Adjustable Steering Column.....	97
Rear Occupant Alert System Limitations.....	157	Rebooting the Displays.....	471	Resetting the Trip Computer.....	126
Rear Occupant Alert System Precautions.....	157	Recovery Towing.....	379	Resetting Tire Pressure Monitoring System.....	447
Rear Occupant Alert System.....	157	Accessing the Front Towing Point.....	379	Restarting the Engine.....	181
Rear Occupant Alert System Settings.....	158	Recreationally Towing Your Vehicle - 4x2.....	384	Resuming the Set Speed.....	261
Rear Parking Aid.....	244	Recreationally Towing Your Vehicle - 4x4.....	382	Reverse Brake Assist Indicators.....	220
Locating the Rear Parking Aid Sensors.....	244	Refueling.....	187	Reverse Brake Assist Precautions.....	219
Rear Parking Aid Audible Warnings.....	244	Refueling System Overview.....	187	Reverse Brake Assist.....	219
Rear Parking Aid Limitations.....	244	Refueling Your Vehicle.....	187	Reverse Brake Assist – Troubleshooting.....	221
What is the Rear Parking Aid.....	244	Releasing the Electric Parking Brake if the Vehicle Battery Has Run Out of Charge.....	217	Reverse Brake Assist – Troubleshooting.....	221
Rear Passenger Audio Controls.....	468	Remote Control Limitations.....	64	Reverse Brake Assist – Frequently Asked Questions.....	222
Rear Passenger Climate Control Indicators.....	136	Remote Start.....	127	Reverse Brake Assist – Information Messages.....	221
Rear Passenger Climate Control.....	135	Remote Start Settings.....	128	Reverse Wipe.....	100
Rear Auto Mode.....	136	Removing the Key Blade.....	65	Reverse Wipe Settings.....	100
Rear Seats.....	147	Removing Your Vehicle From Storage.....	424	What Is Reverse Wipe.....	100
Heated Seats.....	155	Repairing Minor Paint Damage.....	421	Roadside Assistance.....	374
Manual Seats.....	147	Replacement Parts Recommendation.....	562	Rollover Warning.....	498
Power Seats.....	152	Replacing a Lost Key or Remote Control.....	66	Roof Rack.....	324
Rear View Camera Guide Lines.....	249	Replacing the Cabin Air Filter.....	137	Roof Rack Load Capacities.....	325
Rear View Camera Precautions.....	248	Replacing the Front Wiper Blades.....	100	Roof Rack Precautions.....	324
Rear View Camera.....	248	Replacing the Rear Wiper Blades.....	101	Running-In	
Rear View Camera Settings.....	249	Reporting Safety Defects in Canada.....	500	See: Breaking-In.....	370
Rear View Camera Settings.....	249	Reporting Safety Defects in the United States.....	499	Running Out of Fuel.....	185
Switching Rear View Camera Delay On and Off.....	250			Adding Fuel From a Portable Fuel Container.....	186
Switching the Rear View Camera View.....	250			Filling a Portable Fuel Container.....	185

Index

S	
Satellite Radio.....	465
Locating the Satellite Radio Identification Number.....	466
Satellite Radio Limitations.....	466
Satellite Radio Settings.....	466
Selecting a Channel.....	466
Setting an Alert.....	467
What Is Satellite Radio.....	465
Scheduled Maintenance.....	490
Seatbelt Extensions.....	51
Seatbelt Precautions.....	45
Seatbelt Reminder.....	49
How Does the Seatbelt Reminder Work.....	49
Seatbelt Reminder Audible Warnings.....	50
Seatbelt Reminder Indicators.....	49
Switching the Seatbelt Reminder On and Off.....	50
Seatbelts.....	45
Automatic Locking Mode.....	47
Seatbelt Reminder.....	49
Sensitive Locking Mode.....	47
SecuriCode See: Keyless Entry Keypad.....	78
Security.....	90
Anti-Theft Alarm System.....	90
Passive Anti-Theft System.....	90
Security – Troubleshooting.....	91
Security – Troubleshooting.....	91
Security – Frequently Asked Questions.....	92
Security – Information Messages.....	91
Selecting a Drive Mode – 4x2.....	280
Selecting a Drive Mode – 4x4.....	280
Selecting a Four-Wheel Drive Mode.....	199
Selecting the Audio Source.....	462
Sending and Receiving a Text Message.....	477
Sensitive Locking Mode.....	47
How Does Sensitive Locking Mode Work.....	47
What is Sensitive Locking Mode.....	47
Service Data.....	25
Setting a Memory Preset.....	463
Settings Data.....	26
Settings.....	471
Setting the Adaptive Cruise Control Gap.....	260
Setting the Adaptive Cruise Control Speed.....	259
Setting the Blower Motor Speed.....	130
Setting the Clock and Date.....	463
Setting the Hill Descent Speed.....	238
Setting the Temperature.....	130
Setting the Trail Control Speed.....	231
Setting Up a Vehicle Hotspot.....	461
Setting Up the Trailer Backup Assistance for a Conventional Trailer.....	352
Applying the Trailer Reversing Aid Sticker.....	354
Calibrating the System.....	354
Configuring the Trailer.....	352
Setting Up Trailer Reverse Guidance for a Conventional Trailer.....	362
Applying the Trailer Reverse Aid Sticker.....	363
Calibrating the System.....	364
Configuring the Trailer.....	362
Setting Your Default Assistant.....	472
Shifting Your Immobile Vehicle Out of Park (P).....	195
Sitting in the Correct Position.....	138
Software Update Indicators.....	484
Software Update Settings.....	483
Software Update See: Software Update Settings.....	483
See: Vehicle Software Updates.....	483
Sounding the Panic Alarm.....	65
Speedometer.....	125
Speed Sign Recognition Indicators.....	317
Speed Sign Recognition Limitations.....	316
Speed Sign Recognition Precautions.....	316
Speed Sign Recognition Settings.....	317
Speed Sign Recognition.....	316
Speed Sign Recognition – Troubleshooting.....	317
Speed Sign Recognition – Troubleshooting.....	317
Speed Sign Recognition – Frequently Asked Questions.....	318
Speed Sign Recognition – Information Messages.....	317
Splitgate Settings.....	84
Splitgate.....	82
Splitgate – Troubleshooting.....	87
Splitgate – Troubleshooting.....	87
Splitgate – Frequently Asked Questions.....	89
Splitgate – Information Messages.....	88

Index

Splitgate – Warning Lamps.....	87	Stopping the Engine.....	181	Switching Defrost On and Off.....	129
Stability Control Indicator.....	230	Stopping the Engine When Your Vehicle is		Switching Driver Alert On and Off.....	320
Stability Control.....	227	Moving.....	175	Switching Easy Entry and Exit On and	
Starting and Stopping the Engine –		Stopping the Engine When Your Vehicle is		Off.....	81
Precautions.....	173	Stationary.....	175	Switching Exit Warning On and Off.....	302
Starting and Stopping the Engine.....	173	Storage.....	171	Switching From Adaptive Cruise Control to	
Automatic Engine Stop.....	176	Center Console.....	171	Cruise Control.....	263
Engine Block Heater.....	174	Glove Compartment.....	171	Switching Hill Descent Control On and	
Starting and Stopping the Engine –		Overhead Storage.....	171	Off.....	238
Troubleshooting.....	178	Under Floor Storage.....	172	Switching Maximum Cooling On and	
Starting the Engine.....	174	Storing Your Vehicle.....	423	Off.....	130
Stopping the Engine.....	175	Sunroof		Switching Maximum Defrost On and	
Starting and Stopping the Engine –		See: Glass Roof.....	122	Off.....	129
Troubleshooting.....	178	Switching Adaptive Cruise Control On and		Switching Parking Aid On and Off.....	243
Starting and Stopping the Engine – Frequently		Off.....	258	Switching Pre-Collision Assist On and	
Asked Questions.....	179	Switching Air Conditioning On and		Off.....	311
Starting and Stopping the Engine –		Off.....	129	Switching Recirculated Air On and	
Information Messages.....	178	Switching All of the Interior Lamps On and		Off.....	129
Starting and Stopping the Engine – Warning		Off.....	114	Switching Repeat Mode On and Off.....	468
Lamps.....	178	Switching Android Auto™ On and		Switching Reverse Brake Assist On and	
Starting the Engine.....	174	Off.....	478	Off.....	220
Restarting the Engine After Stopping It.....	174	Switching Apple CarPlay On and Off.....	478	Switching Shuffle Mode On and Off.....	468
Starting a Gasoline Engine.....	174	Switching Auto Hold On and Off.....	224	Switching Stability Control On and	
Status Bar.....	469	Switching Auto-Start-Stop On and		Off.....	228
Steering.....	240	Off.....	181	Switching Text Message Notification On	
Electric Power Steering.....	240	Switching Blind Spot Information System		and Off.....	478
Steering – Troubleshooting.....	240	On and Off.....	297	Switching the Audio Unit On and Off.....	462
Steering – Troubleshooting.....	240	Switching BlueCruise On and Off.....	273	Switching the Electronic Locking	
Steering – Frequently Asked Questions.....	242	Switching Climate Control On and		Differential On and Off.....	209
Steering – Information Messages.....	241	Off.....	129	Switching the Front Interior Lamps On and	
Steering – Warning Lamps.....	240	Switching Cross Traffic Alert On and		Off.....	114
Steering Wheel.....	95	Off.....	306		

Index

Switching the Hazard Flashers On and Off.....	375
Switching the Heated Mirrors On and Off.....	130
Switching the Heated Rear Window On and Off.....	130
Switching the Heated Steering Wheel On and Off - Vehicles With: Heated Steering Wheel.....	97
Switching the Lane Keeping System Mode.....	287
Switching the Lane Keeping System On and Off.....	287
Switching the Rear Interior Lamps On and Off.....	114
Switching the Rear Passenger Audio Controls On and Off.....	468
Switching the Rear Passenger Climate Controls On and Off.....	135
Switching the Rear Window Wiper On and Off.....	100
Switching Traction Control On and Off.....	225
Switching Trail Control On and Off.....	231
Switching Trailer Backup Assistance On and Off.....	355
Switching Trailer Hitching Assistance On and Off.....	349
Switching Trailer Reverse Guidance On and Off.....	365
Switching Trailer Sway Control On and Off.....	347

Switching Trail Turn Assist On and Off.....	236
Symbols Glossary.....	19
Symbols Used On Your Instrument Cluster.....	21
Symbols Used on Your Vehicle.....	19
System Update See: Software Update Settings.....	483
See: Vehicle Software Updates.....	483

T

Tachometer.....	125
Tailgate Settings.....	87
Temporary Neutral Mode.....	194
The Better Business Bureau Auto Line Program - United States of America.....	498
The Mediation and Arbitration Program - Canada.....	499
Tire Care.....	437
Tire Pressure Monitoring System Limitations.....	446
Tire Pressure Monitoring System Overview.....	445
Tire Pressure Monitoring System Precautions.....	446
Tire Pressure Monitoring System - Tire Pressure Monitoring System – Troubleshooting.....	448

Tire Pressure Monitoring System – Troubleshooting.....	448
Tire Pressure Monitoring System – Information Messages.....	449
Tire Pressure Monitoring System – Warning Lamps.....	448
Tire Replacement Requirements.....	432
Tire Rotation.....	443
Towing a Trailer Limitations.....	336
Towing a Trailer Precautions.....	335
Towing a Trailer.....	335
Towing a Trailer – Troubleshooting.....	340
Towing Weights and Dimensions.....	338
Towing a Trailer – Troubleshooting.....	340
Towing a Trailer – Information Messages.....	340
Towing Weights and Dimensions.....	338
Calculating the Maximum Loaded Trailer Weight for Your Vehicle.....	339
Recommended Towing Weights.....	338
What Is the Maximum Loaded Trailer Weight.....	339
Towing Your Vehicle Precautions.....	382
Towing Your Vehicle.....	382
Towing Your Vehicle – Troubleshooting.....	384
Towing Your Vehicle – Troubleshooting.....	384
Towing Your Vehicle – Information Messages.....	384
Traction Control Indicator.....	225

Index

Traction Control.....	225	Trailer Hitching Assistance		Trail Turn Assist Limitations.....	236
Traction Control – Troubleshooting.....	226	Precautions.....	348	Trail Turn Assist Precautions.....	236
Traction Control – Troubleshooting.....	226	Trailer Hitching Assistance.....	348	Trail Turn Assist.....	236
Traction Control – Information		Trailer Lighting Check.....	333	Trail Turn Assist – Troubleshooting.....	237
Messages.....	226	Trailer Reverse Guidance		Trail Turn Assist – Troubleshooting.....	237
Traction Control – Warning Lamps.....	226	Precautions.....	362	Trail Turn Assist – Frequently Asked	
Trail Control Indicators.....	231	Trailer Reverse Guidance.....	362	Questions.....	237
Trail Control.....	231	Setting Up Trailer Reverse Guidance for a		Trail Turn Assist – Information	
Trail Control – Troubleshooting.....	234	Conventional Trailer.....	362	Messages.....	237
Trail One Pedal Drive.....	232	Trailer Reverse Guidance –		Transfer Case Fluid Capacity and	
Trail One Pedal Drive –		Troubleshooting.....	366	Specification.....	201
Troubleshooting.....	233	Trailer Reverse Guidance –		Transporting the Vehicle.....	380
Trail Control – Troubleshooting.....	234	Troubleshooting.....	366	Trip Computer.....	126
Trail Control – Information Messages.....	234	Trailer Reverse Guidance – Frequently Asked			
Trailer Backup Assistance		Questions.....	368	U	
Precautions.....	352	Trailer Reverse Guidance – Information		Under Floor Storage.....	172
Trailer Backup Assistance.....	352	Messages.....	366	Locating the Rear Under Floor Storage.....	172
Setting Up the Trailer Backup Assistance for		Trailer Sway Control Precautions.....	347	Under Hood Fuse Box.....	385
a Conventional Trailer.....	352	Trailer Sway Control.....	347	Accessing the Under Hood Fuse Box.....	385
Trailer Backup Assistance –		Trailer Towing Hints.....	336	Identifying the Fuses in the Under Hood Fuse	
Troubleshooting.....	358	Trail One Pedal Drive.....	232	Box.....	386
Trailer Backup Assistance –		Switching Trail One Pedal Drive On and		Locating the Under Hood Fuse Box.....	385
Troubleshooting.....	358	Off.....	232	Under Hood Overview.....	397
Trailer Backup Assistance – Frequently Asked		Trail One Pedal Drive Indicators.....	233	USB Ports.....	164
Questions.....	360	Trail One Pedal Drive Limitations.....	232	Using Auto Hold.....	224
Trailer Backup Assistance – Information		Trail One Pedal Drive Precautions.....	232	Using Keyless Entry.....	76
Messages.....	358	What Is Trail One Pedal Drive.....	232	Using Progressive Range Selection.....	196
Trailer Brake Precautions.....	335	Trail One Pedal Drive –		Using Remote Start - Vehicles With: Ford	
Trailer Hitching Assistance Indicators.....	351	Troubleshooting.....	233	Mobile App/Phone as a Key.....	127
Trailer Hitching Assistance		Trail One Pedal Drive – Information		Using Remote Start - Vehicles With:	
Limitations.....	349	Messages.....	233	Remote Control.....	127
		Trail Turn Assist Indicators.....	236		

Index

Using Snow Chains.....	434	Vehicle Identification.....	457	What Is Auto-Start-Stop.....	181
Using the Backup Start Passcode.....	70	Vehicle Identification Number.....	457	What Is Blind Spot Information	
Using the Controls on the Steering		Vehicle Software Updates.....	483	System.....	296
Wheel.....	95	Vehicle Specifications.....	415	What Is BlueCruise.....	271
Using the Integrated Trailer Brake		Vehicle System Reset.....	485	What Is Cross Traffic Alert.....	304
Controller.....	342	Ventilated Seats.....	146	What Is Drive Mode Control.....	280
Using the Keyless Entry Keypad.....	80	Switching the Ventilated Seats On and		What Is Driver Alert.....	319
Using the Memory Function.....	480	Off.....	146	What Is Exit Warning.....	301
Using the Remote Control.....	64	Ventilated Seat Precautions.....	146	What Is Ford Protect.....	488
Using the Trailer Backup Assistance		Ventilation		What Is Hill Descent Control.....	238
Controller.....	355	See: Climate Control.....	129	What Is Hill Start Assist.....	223
Using the Trailer Backup Assistance		Venting the Glass Roof.....	123	What Is Keyless Entry.....	76
Views.....	356	Viewing the Tire Pressures.....	447	What Is Phone as a Key.....	69
Using the Valet Mode.....	69	Visual Search.....	29	What Is Pre-Collision Assist.....	308
Using This Publication.....	18	Voice Interaction.....	472	What Is Reverse Brake Assist.....	219
Using Trailer Hitching Assistance.....	350	W		What Is Speed Sign Recognition.....	316
Using Trailer Reverse Guidance		Warranty Information.....	564	What Is the 360 Degree Camera.....	251
Views.....	365	Washers.....	102	What Is the Cabin Air Filter.....	137
V		Adding Washer Fluid.....	103	What Is the Catalytic Converter.....	190
Vehicle Care.....	417	Switching the Courtesy Wipe On and		What Is the Electric Parking Brake.....	216
Cleaning the Exterior.....	418	Off.....	102	What Is the Electronic Locking	
Cleaning the Interior.....	419	Using the Rear Window Washer.....	102	Differential.....	209
Vehicle Hotspot Settings.....	461	Using the Windshield Washer.....	102	What Is the Gross Axle Weight	
Vehicle Hotspot.....	461	Washer Fluid Specification.....	103	Rating.....	322
Vehicle Identification Number.....	457	Washer Precautions.....	102	What Is the Gross Combined Weight	
Locating the Vehicle Identification		Washers		Rating.....	322
Number.....	457	See: Wipers and Washers.....	99	What Is the Gross Vehicle Weight	
Vehicle Identification Number		Waxing Your Vehicle.....	422	Rating.....	322
Overview.....	457	What Is 911 Assist.....	62	What Is the Integrated Trailer Brake	
		What Is a Connected Vehicle.....	458	Controller.....	342

Index

What Is the Personal Safety System.....	52	Wipers and Washers.....	99
What Is the Power Outlet.....	166	Autowipers.....	99
What is the Rear Occupant Alert System.....	157	Reverse Wipe.....	100
What Is the Rear View Camera.....	248	Washers.....	102
What Is the Tire Pressure Monitoring System.....	445	Wipers.....	99
What Is the Wireless Accessory Charger.....	169	Wipers and Washers – Troubleshooting.....	104
What Is Traction Control.....	225	Wipers.....	99
What Is Trail Control.....	231	Switching Windshield Wipers On and Off.....	99
What is Trailer Backup Assistance.....	352	Wiper Precautions.....	99
What Is Trailer Hitching Assistance.....	348	Wireless Accessory Charger Precautions.....	169
What Is Trailer Reverse Guidance.....	362	Wireless Accessory Charger.....	169
What Is Trail Turn Assist.....	236		
What is Voice Interaction.....	472		
Wheel and Tire Information.....	425		
Wheel Nuts.....	456		
Wi Fi See: Connecting the Vehicle to a Wi-Fi Network.....	458		
Window Bounce-Back.....	117		
Overriding Window Bounce-Back.....	117		
What Is Window Bounce-Back.....	117		
Windows.....	116		
Global Opening and Closing.....	116		
Window Bounce-Back.....	117		
Wipers and Washers – Troubleshooting.....	104		
Wipers and Washers – Frequently Asked Questions.....	104		
Wipers and Washers – Warning Lamps.....	104		

, Edition date: 202406