

# OWNER'S MANUAL

## 2024 FIAT 500e



**FIAT**

This Owner's Manual illustrates and describes the operation of features and equipment that are either standard or optional on this vehicle. This manual may also include a description of features and equipment that are no longer available or were not ordered on this vehicle. Please disregard any features and equipment described in this manual that are not on this vehicle. FCA US LLC reserves the right to make changes in design and specifications, and/or make additions to or improvements to its products without imposing any obligation upon itself to install them on products previously manufactured.

With respect to any vehicles sold in Canada, the name FCA US LLC shall be deemed to be deleted and the name FCA Canada Inc. used in substitution therefore.

This Owner's Manual is intended to familiarize you with the important features of your vehicle. Your most up-to-date Owner's Manual, Radio Instruction Manual and Warranty Booklet can be found by visiting the website on the back cover.

## ROADSIDE ASSISTANCE

**24 HOURS, 7 DAYS A WEEK AT YOUR SERVICE.**

**CALL 1-888-242-6342 OR VISIT [FIAT.RSAHELP.COM](http://FIAT.RSAHELP.COM) (USA)**

**CALL 1-800-363-4869 OR VISIT [FCA.ROADSIDEAID.COM](http://FCA.ROADSIDEAID.COM) (CANADA)**

**SERVICES:** Flat Tire Service, Out Of Gas/Fuel Delivery, Battery Jump Assistance, Lockout Service and Towing Service

FCA US LLC reserves the right to modify the terms or discontinue the Roadside Assistance Program at any time.

The Roadside Assistance Program is subject to restrictions and conditions of use, that are determined solely by FCA US LLC.

Please see the Customer Assistance chapter in this Owner's Manual for further information.

**⚠ WARNING:** Operating, servicing and maintaining a passenger vehicle or off-highway motor vehicle can expose you to chemicals including engine exhaust, carbon monoxide, phthalates, and lead, which are known to the State of California to cause cancer and birth defects or other reproductive harm. To minimize exposure, avoid breathing exhaust, do not idle the engine except as necessary, service your vehicle in a well-ventilated area and wear gloves or wash your hands frequently when servicing your vehicle. For more information go to: **[www.P65Warnings.ca.gov/passenger-vehicle](http://www.P65Warnings.ca.gov/passenger-vehicle)**.

Vehicle images are for illustration purposes only. Actual products sold may vary.

**FIAT**

# CONTENTS

1	INTRODUCTION.....	6
2	GETTING TO KNOW YOUR VEHICLE.....	12
3	GETTING TO KNOW YOUR INSTRUMENT PANEL.....	56
4	STARTING AND OPERATING.....	70
5	MULTIMEDIA.....	113
6	SAFETY.....	131
7	IN CASE OF EMERGENCY.....	167
8	SERVICING AND MAINTENANCE.....	178
9	TECHNICAL SPECIFICATIONS.....	205
10	CUSTOMER ASSISTANCE.....	208
11	INDEX.....	214

1

2

3

4

5

6

7

8

9

10

11

## INTRODUCTION

SYMBOLS KEY.....	7
VEHICLE MODIFICATIONS/ALTERATIONS .....	7
SYMBOL GLOSSARY .....	7

## GETTING TO KNOW YOUR VEHICLE

HIGH VOLTAGE BATTERY .....	12
Battery Conditioning.....	13
HIGH VOLTAGE CHARGING OPERATION .....	14
SAE J1772 Charging Inlet.....	14
AC Level 1 Charging (120 Volt, 12 Amp) — If Equipped.....	14
AC Level 2 Charging (240 Volt, 32 Amp).....	20
DC Charging.....	21
Vehicle Charge Indicators.....	21
Electric Vehicle App.....	22
KEYS .....	24
Key Fob .....	24
SENTRY KEY .....	27
IGNITION SWITCH .....	27
Keyless Enter 'n Go™ Ignition.....	27
DOORS .....	28
Power Door Locks.....	28
Door Opening .....	29
Keyless Enter 'n Go™ — Passive Entry .....	29
Automatic Door Locks — If Equipped .....	31
Emergency Closing and Opening.....	31
STEERING WHEEL.....	32
Manual Tilt/Telescoping Steering Column ..	32
SEATS .....	33
Manual Adjustment (Front Seats).....	33

Manual Adjustment (Rear Seats).....	34
Heated Seats — If Equipped .....	34
Head Restraints .....	35
UCONNECT VOICE RECOGNITION QUICK TIPS — IF EQUIPPED.....	36
Introducing Voice Recognition.....	36
Basic Voice Commands.....	36
Get Started.....	36
Additional Information.....	37
MIRRORS .....	37
Inside Rearview Mirror.....	37
Vanity Mirror .....	37
Outside Mirrors .....	37
Power Mirrors .....	38
Folding Mirrors.....	38
Heated Mirrors — If Equipped .....	38
EXTERIOR LIGHTS .....	38
Multifunction Lever .....	38
Headlights .....	39
Automatic Headlights .....	39
Daytime Running Lights .....	39
Automatic lighting Control (Autolight) — Dusk Sensor .....	39
High Beams .....	39
Automatic High Beam Headlamp Control — If Equipped .....	39
Flash-To-Pass .....	40
Parking Lights .....	40
Follow Me Home/Headlight Delay.....	40
Rear Fog Lights .....	40
Turn Signals .....	40

Lane Change Assist .....	40
INTERIOR LIGHTS .....	40
Front Courtesy Light.....	40
Cargo Area Lights.....	41
WIPERS AND WASHERS .....	42
Front Windshield Wiper Operation.....	42
Rear Windshield Wiper .....	42
Rain Sensing Wipers — If Equipped .....	43
0456-CLIMATE-CONTROLS.....	43
0456-Automatic-Temperature-Control- Overview.....	43
0456-Automatic-Climate-Controls.....	45
Climate Voice Commands .....	46
Scheduled Cabin Conditioning (SCC).....	46
0456-Operating Tips.....	47
INTERIOR STORAGE AND EQUIPMENT .....	48
Storage .....	48
Cupholders .....	49
USB/Media Player Control .....	49
Electrical Power Outlets .....	50
Wireless Charging Pad.....	51
Sun Visors.....	52
WINDOWS .....	52
Power Window Controls.....	52
Automatic Window Features .....	52
Reset Auto-Up .....	53
HOOD .....	53
Opening The Hood .....	53
To Close The Hood.....	54
LIFTGATE .....	54
To Unlock/Open The Liftgate .....	54

Lock/Close The Liftgate .....	54	Exceeding The Set Speed.....	75	To Resume.....	93
Cargo Area Features .....	55	Deactivation.....	75	Setting The Distance Between Vehicles.....	93
<b>GETTING TO KNOW YOUR</b>		<b>INTELLIGENT SPEED ASSIST (ISA) .....</b>	<b>75</b>	Overtaking Aid Function.....	94
<b>INSTRUMENT PANEL</b>		Activation.....	75	Speed Reductions On Bends.....	95
<b>INSTRUMENT CLUSTER .....</b>	<b>56</b>	Exceeding The Set Speed.....	76	Deactivation.....	95
Instrument Cluster Descriptions .....	57	Deactivation.....	76	System Limited Operation Warning.....	95
<b>INSTRUMENT CLUSTER DISPLAY .....</b>	<b>57</b>	<b>TRAFFIC SIGN RECOGNITION SYSTEM .....</b>	<b>76</b>	Precautions While Driving With ACC.....	95
Location and Controls.....	57	Activation/Deactivation.....	76	<b>CO-DRIVER SYSTEM WITH STOP&amp;GO -</b>	
Stop Safely Vehicle Will Shut Off Soon.....	58	Traffic Sign Recognition Warning Modes....	77	<b>TRAFFIC JAM ASSIST- IF EQUIPPED .....</b>	<b>97</b>
Fire Danger! Pull Over Now! Exit Quickly!....	58	Indications On The Display.....	77	Operation.....	97
Instrument Cluster Display Main Menu.....	59	Navigation System Integration.....	78	Activation and Deactivation.....	97
<b>WARNING LIGHTS AND MESSAGES .....</b>	<b>62</b>	<b>CRUISE CONTROL SYSTEMS - IF EQUIPPED ...</b>	<b>78</b>	Indications On The Display.....	98
Red Warning Lights.....	62	Cruise Control.....	78	System Status.....	98
Yellow Warning Lights.....	65	Adaptive Cruise Control (ACC).....	79	System Operation/Limitations.....	99
Yellow Indicator Lights.....	67	<b>CO-DRIVER SYSTEM WITH FOLLOW TO</b>		<b>FRONT/REAR PARK ASSIST - IF EQUIPPED ....</b>	<b>99</b>
Green Indicator Lights.....	68	<b>STOP - TRAFFIC JAM ASSIST .....</b>	<b>87</b>	Park Assist Sensors.....	100
White Indicator Lights.....	68	Operation.....	87	Park Assist Warning Display.....	100
Blue Indicator Lights.....	69	Activation and Deactivation.....	87	Park Assist Display.....	100
		Indications On The Display.....	88	Enabling And Disabling Park Assist.....	103
<b>STARTING AND OPERATING</b>		System Status.....	88	Service The Park Assist System.....	103
<b>STARTING THE VEHICLE .....</b>	<b>70</b>	System Availability.....	89	Cleaning The Park Assist System.....	104
Single Speed Transmission.....	70	System Operation/Limitations.....	89	Park Assist System Usage Precautions.....	104
Normal Starting.....	70	<b>CO-DRIVER SYSTEM WITH STOP &amp; GO -</b>		Side Distance Warning System - If	
<b>ELECTRIC PARK BRAKE (EPB) .....</b>	<b>70</b>	<b>ADAPTIVE CRUISE CONTROL WITH</b>		Equipped .....	104
<b>SINGLE SPEED TRANSMISSION .....</b>	<b>72</b>	<b>STOP &amp; GO - IF EQUIPPED .....</b>	<b>89</b>	<b>LANESENSE - IF EQUIPPED .....</b>	<b>106</b>
Gear Ranges.....	72	Activation/Deactivation.....	90	LaneSense Operation.....	106
Auto Park.....	73	Setting The Desired Speed.....	90	Turning LaneSense On Or Off.....	106
<b>E-MODE SELECTOR .....</b>	<b>73</b>	To Vary The Speed Setting.....	92	Changing LaneSense Status.....	106
<b>POWER STEERING .....</b>	<b>74</b>	To Vary The Speed With Intelligent		LaneSense Warning Message.....	106
<b>ACTIVE SPEED LIMITER .....</b>	<b>74</b>	Adaptive Cruise Control.....	92	<b>PARKVIEW REAR BACK UP CAMERA .....</b>	<b>108</b>
Activation.....	75	Operation At A Stop.....	92	<b>VEHICLE LOADING .....</b>	<b>109</b>

Certification Label.....	109	AUXILIARY DRIVING SYSTEMS .....	136	Jump Starting Procedure.....	174
TRAILER TOWING .....	110	Blind Spot Monitoring (BSM) – If		IF YOUR ENGINE OVERHEATS .....	175
RECREATIONAL TOWING (BEHIND		Equipped .....	136	FREEING A STUCK VEHICLE .....	176
MOTORHOME, ETC.) .....	110	Forward Collision Warning (FCW) With		TOWING A DISABLED VEHICLE .....	176
Towing This Vehicle Behind Another		Mitigation – If Equipped .....	138	Attaching The Tow Hook .....	177
Vehicle.....	110	indirect Tire Pressure Monitoring		ENHANCED ACCIDENT RESPONSE	
DRIVING TIPS.....	110	System (ITPMS) .....	141	SYSTEM (EARS) .....	177
ENERGY CONSUMPTION REDUCTION.....	110	OCCUPANT RESTRAINT SYSTEMS .....	143	EVENT DATA RECORDER (EDR) .....	177
Driving On Slippery Surfaces .....	111	Occupant Restraint Systems Features .....	143		
Driving Through Water .....	111	Important Safety Precautions .....	144	SERVICING AND MAINTENANCE	
Driving Style .....	112	Seat Belt Systems .....	144	SCHEDULED SERVICING .....	178
Conditions Of Use.....	112	Supplemental Restraint Systems (SRS) .....	149	Maintenance Plan.....	178
		Child Restraints .....	155	UNDERHOOD COMPARTMENT .....	180
MULTIMEDIA		SAFETY TIPS .....	164	Adding Washer Fluid .....	180
UCONNECT SYSTEMS .....	113	Transporting Passengers .....	164	Maintenance-Free Battery 12 Volt .....	180
CYBERSECURITY .....	113	Transporting Pets .....	164	VEHICLE MAINTENANCE .....	181
UCONNECT SETTINGS .....	113	Connected Vehicles .....	165	Air Conditioner Maintenance .....	181
Customer Programmable Features.....	113	Safety Checks You Should Make Inside		Body Lubrication .....	181
STEERING WHEEL AUDIO CONTROLS .....	129	The Vehicle .....	165	Windshield Wiper Blades .....	182
Radio Operation.....	129	Periodic Safety Checks You Should		Cooling System .....	182
Media Mode.....	129	Make Outside The Vehicle .....	166	Brake System .....	184
RADIO OPERATION AND MOBILE PHONES.....	129			Automatic Transmission .....	185
Regulatory And Safety Information.....	129	IN CASE OF EMERGENCY		Fuses .....	186
		HAZARD WARNING FLASHERS .....	167	Bulb Replacement .....	190
SAFETY		SOS AND ASSIST SYSTEM .....	167	TIRES.....	192
SAFETY FEATURES.....	131	TIRE SERVICE KIT .....	169	Tire Safety Information .....	192
Anti-Lock Brake System (ABS) .....	131	Description.....	169	Tires – General Information .....	196
Drowsy Driver Detection .....	131	Inflation Procedure.....	170	Tire Types.....	199
Audible Pedestrian Warning System .....	132	Checking And Restoring Tire Pressure.....	172	Wheel And Wheel Trim Care .....	200
Regenerative Braking System (RBS) .....	132	Sealant Cartridge Replacement.....	173	Tire Chains (Traction Devices) .....	201
Rear Seat Reminder Alert (RSRA) .....	133	JUMP STARTING .....	173	Tire Rotation Recommendations .....	201
Electronic Brake Control (EBC) System .....	133	Preparations For Jump Start.....	174		

DEPARTMENT OF TRANSPORTATION	
UNIFORM TIRE QUALITY GRADES .....	201
Treadwear.....	201
Traction Grades.....	201
Temperature Grades.....	201
STORING THE VEHICLE .....	202
BODYWORK.....	202
Protection From Atmospheric Agents .....	202
Body And Underbody Maintenance.....	202
Preserving The Bodywork.....	203
INTERIORS .....	203
Seats And Fabric Parts.....	203
Plastic And Coated Parts.....	204
Leather Surfaces.....	204
Glass Surfaces .....	204
TECHNICAL SPECIFICATIONS	
VEHICLE IDENTIFICATION NUMBER (VIN) .....	205
BRAKE SYSTEM .....	205
WHEEL AND TIRE TORQUE SPECIFICATIONS .....	205
Torque Specifications.....	205
FLUID CAPACITIES .....	206
DRIVE TRANSMISSION FLUIDS AND	
LUBRICANTS .....	206
CHASSIS FLUIDS AND LUBRICANTS .....	207
CUSTOMER ASSISTANCE	
SUGGESTIONS FOR OBTAINING SERVICE	
FOR YOUR VEHICLE .....	208
Prepare For The Appointment.....	208
Prepare A List.....	208
Be Reasonable With Requests.....	208
IF YOU NEED ASSISTANCE .....	208
Roadside Assistance.....	208
FCA US LLC Customer Center.....	209
FCA Canada Inc. Customer Center.....	209
In Mexico Contact.....	209
Puerto Rico And U.S. Virgin Islands .....	209
Customer Assistance For The Hearing	
Or Speech Impaired (TDD/TTY).....	209
Service Contract .....	210
WARRANTY INFORMATION .....	210
MOPAR® PARTS.....	210
REPORTING SAFETY DEFECTS .....	210
In The 50 United States And	
Washington, D.C.....	210
In Canada.....	211
ORDERING AND ACCESSING OWNER'S	
INFORMATION .....	211
CHANGE OF OWNERSHIP OR ADDRESS.....	211
GENERAL INFORMATION .....	211

# INTRODUCTION

Dear Customer,

Congratulations on the purchase of your new FIAT® vehicle. Be assured that it represents precision workmanship, distinctive styling, and high quality.



This Owner's Manual has been prepared with the assistance of service and engineering specialists to acquaint you with the operation and maintenance of your vehicle. It is supplemented by customer-oriented documents. Within this information, you will find a description of the services that FCA US LLC offers to its customers as well as the details of the terms and conditions for maintaining its validity. Please take the time to read all of these publications carefully before driving your vehicle for the first time. Following the instructions, recommendations, tips, and important warnings in this manual will help ensure safe and enjoyable operation of your vehicle. Be sure you are familiar with all vehicle controls, particularly those used for braking, steering, transmission, and transfer case shifting (if equipped). Learn how your vehicle handles on different road surfaces. Your driving skills will improve with experience.

This Owner's Manual describes all versions of this vehicle. Options and equipment dedicated to specific markets or versions are not expressly indicated in the text. Therefore, you should only consider the information that is related to the trim level, engine, and version that you have purchased. Any content introduced throughout the Owner's Information, which may or may not be applicable to your vehicle, will be identified with the wording "If Equipped". All data contained in this publication are intended to help you use your vehicle in the best possible way. FCA US LLC aims at a constant improvement of the vehicles produced. For this reason, it reserves the right to make changes to the model described for technical and/or commercial reasons. For further information, contact an authorized dealer.

When it comes to service, remember that authorized dealers know your vehicle best, have factory-trained technicians, genuine Mopar® parts, and care about your satisfaction.



## SYMBOLS KEY

<b>WARNING!</b>	These statements apply to operating procedures that could result in a collision, bodily injury and/or death.
<b>CAUTION!</b>	These statements apply to procedures that could result in damage to your vehicle.
<b>NOTE:</b>	A suggestion which will improve installation, operation, and reliability. If not followed, may result in damage.
<b>TIP:</b>	General ideas/solutions/suggestions on easier use of the product or functionality.
 <b>PAGE REFERENCE ARROW</b>	Follow this reference for additional information on a particular feature.
 <b>FOOTNOTE</b>	Supplementary and relevant information pertaining to the topic.

If you do not read the entire Owner's Manual, you may miss important information. Observe all Cautions and Warnings.

## VEHICLE MODIFICATIONS/ALTERATIONS













<b>WARNING!</b>
Any modifications or alterations to this vehicle could seriously affect its roadworthiness and safety and may lead to a collision resulting in serious injury or death.









## SYMBOL GLOSSARY



Some car components have colored labels with symbols indicating precautions to be observed when using this component. It is important to follow all warnings when operating your vehicle. See below for the definition of each symbol  page 62.





### NOTE:









Warning and Indicator lights are different based upon equipment options and current vehicle status. Some telltales are optional and may not appear.









<b>Red Warning Lights</b>	
	Air Bag Warning Light  page 62
	Brake Warning Light  page 62
	Battery Charge Warning Light  page 63
	Door Open Warning Light  page 63
	Drowsy Driver Detected Warning Light  page 63
	E-Latch Fault Warning Light  page 63









<b>Red Warning Lights</b>	
	Electric Power Steering (EPS) Fault Warning Light ⇒ page 63
	Electric System Fail ⇒ page 64
	Hood Open Warning Light ⇒ page 64
	Rear Cargo Door Warning Light ⇒ page 64
	Plug Status Fault Warning Light ⇒ page 64
	Seat Belt Reminder Warning Light ⇒ page 64
	SOS Battery Fault Warning Light – If Equipped ⇒ page 64
	SOS Fault Warning Light – If Equipped ⇒ page 64
	Traction Battery Fault Warning Light ⇒ page 64









<b>Red Warning Lights</b>	
	Low High-Voltage Battery Charge ⇒ page 64
	Torque Limited Warning Light ⇒ page 65
	Transmission Fault Warning Light ⇒ page 64





<b>Yellow Warning Lights</b>	
	Acoustic Vehicle Alerting System Fault Warning Light ⇒ page 65
	Anti-Lock Brake System (ABS) Warning Light ⇒ page 65
	Adaptive Cruise Control (ACC) Fault Warning Light ⇒ page 65
	Automatic High Beam Warning Light ⇒ page 65
	Blind Spot Detection System Failure ⇒ page 65





Yellow Warning Lights	
	Brake Failure ⇒ page 65
	Drowsiness Detected Warning Light ⇒ page 65
	Electronic Park Brake Warning Light ⇒ page 65
	Electronic Stability Control (ESC) OFF Warning Light ⇒ page 65
	Electronic Stability Control (ESC) Warning Light ⇒ page 65
	Forward Collision Warning (FCW) Fault Light/Camera Blinded ⇒ page 66
	Immobilizer Fail / VPS Electrical Alarm Warning Light ⇒ page 66
	Keyless System Failure Indicator Light ⇒ page 66
	Low Washer Fluid Warning Light ⇒ page 66

Yellow Warning Lights	
	Park Sensor System Failure ⇒ page 66
	Rain Sensor Failure Indicator Light ⇒ page 66
	Service Lanesense Warning Light ⇒ page 66
	Service Required/Call For Service Warning Light ⇒ page 66
	Speed Limiter Failure ⇒ page 66
	indirect Tire Pressure Monitoring System (iTMS) Warning Light ⇒ page 66
	Traction Battery Cut-off Warning Light ⇒ page 67
	Traffic Sign Recognition (TSR) Fault Warning Light ⇒ page 67

<b>Yellow Warning Lights</b>	
	Twilight Sensor Fault Warning Light ⇒ page 67
<b>Yellow Indicator Lights</b>	
	Exterior Lights Failure Indicator Light ⇒ page 67
	Lane Keeping Assist OFF ⇒ page 67
	Forward Collision Warning (FCW) OFF Indicator Light ⇒ page 67
	Icy Road Condition Indicator Light ⇒ page 67
	Press Brake Indicator Light ⇒ page 67
	Rear Fog Indicator Light ⇒ page 67
	Traffic Sign Recognition (TSR) OFF Light ⇒ page 67

<b>Green Indicator Lights</b>	
	Adaptive Cruise Control (ACC) ⇒ page 68
	Auto HOLD Indicator Light ⇒ page 68
	Automatic High Beam Indicator Light ⇒ page 68
	Cruise Control SET Indicator Light ⇒ page 68
	Intelligent Adaptive Cruise Control (ACC) ⇒ page 68
	Intelligent Speed System Assist ⇒ page 69
	Park/Headlight On Indicator Light ⇒ page 68
	Plugged In Indicator Light ⇒ page 68
	Ready To Drive Indicator Light ⇒ page 68

<b>Green Indicator Lights</b>	
	Speed Limiter ON ⇒ page 69
	Turn Signal Indicator Lights ⇒ page 68
<b>Blue Indicator Lights</b>	
	High Beam Indicator Light ⇒ page 69
<b>White Indicator Lights</b>	
	Adaptive Cruise Control READY (ACC) ⇒ page 68

<b>White Indicator Lights</b>	
	Cruise Control READY Indicator Light ⇒ page 68
	Intelligent Adaptive Cruise Control READY (ACC) ⇒ page 68
	Intelligent Speed Assist READY ⇒ page 69
	Speed Limiter READY ⇒ page 69

# GETTING TO KNOW YOUR VEHICLE

## HIGH VOLTAGE BATTERY

Your vehicle is equipped with a Lithium-ion high voltage battery that is used to power the electric powertrain systems and the 12 volt vehicle electrical system.

The high voltage battery is located under the vehicle. The high voltage battery is maintenance free and designed to last for the life of the vehicle.

Lithium-ion batteries provide the following benefits:

- Lithium-ion batteries are much lighter than other types of rechargeable batteries of the same size.
- Lithium-ion batteries hold their charge; they only lose approximately 3 percent of their charge per month.
- Lithium-ion batteries have no memory, which means that you do not have to completely discharge them before recharging, as with some other batteries.
- Lithium-ion batteries can be recharged and discharged thousands of times.

### HVIL (High Voltage InterLock) Device Disconnect

The HVIL device disconnect should be done using the high voltage interlock loop connector located in the rear luggage box. If your vehicle requires service, see an authorized dealer.

### WARNING!

- Never try to remove the HVIL device. The HVIL device is used when your vehicle requires service by a qualified technician at an authorized dealership. Failure to follow this warning can result in electrical shock, toxic emissions, fire, and other hazards which can cause death or serious injury including severe burns, respiratory injuries, and blindness.
- The high voltage battery and battery case have no parts that you or an unqualified technician can service. Under no circumstances should you or an unqualified technician open, disassemble, penetrate, or tamper with the high voltage battery, battery case, their cables, or connectors. Damage to these components can result in electrical shock, toxic emissions, fire, and other hazards which can cause death or serious injury including severe burns, respiratory injuries, and blindness. You should take the vehicle to an authorized dealership for any service or maintenance on these high voltage components.
- The high voltage system can be hot during and after starting, and when the vehicle is shut off or charging. Be careful of both the high voltage and the high temperature. Failure to do so can result in severe burns.

### Disposal of the High Voltage Battery

Your vehicle's high voltage battery is designed to last the life of your vehicle. See an authorized dealer for information on the disposal of the battery if it should require replacement.

### WARNING!

Your vehicle contains a sealed Lithium-ion high voltage battery. If the battery is disposed of improperly, there is a risk of electrical shock and toxic emissions which can cause severe burns, respiratory injuries, fires, and other hazards resulting in serious injury or death.

### General Information

The vehicle is also equipped with a Battery Management System that is designed to:

- Ensure safe operation
- Maximize driving range
- Maximize the life expectancy of the high voltage battery

### NOTE:

- During vehicle start up and shut down, a clicking noise may be heard from within the vehicle. When the ignition device is moved to ON/RUN, the high voltage battery contactors inside the battery are closed to make the stored electricity inside available

for vehicle use. The clicking noise observed is the sound of these contactors as they open and close and is normal operation for your 500e.

- The operating temperature range of the high voltage battery is -22 °F to 122 °F (-30 °C to 50 °C). If it is attempted to operate the vehicle with the battery outside of these temperature extremes it will not function.
- The Pedestrian Acoustic Warning system will emit a noise from when a gear other than P (Park) is engaged and remains active as long as the car is travelling at a speed of 15 mph (25 km/h). For more information on this system, see  page 132

#### WARNING!

In the event of a collision:

- If your vehicle is still drivable, pull off to the side of the road, when safe to do so, and place the transmission in the PARK position, apply the parking brake, and turn the vehicle off.
- Beware of any exposed high-voltage parts or cables. To avoid electrical shock which can result in serious injury or death, never touch wiring, connectors, and other high-voltage parts, such as the inverter unit and the Lithium-ion battery.
- Leaks or damage to the Lithium-ion battery may result in a fire and toxic emissions which can cause severe burns, respiratory injuries, and other serious injuries or death. If you discover these

*(Continued)*

#### WARNING!

leaks, contact emergency services immediately. Since the fluid leak may be Lithium Manganate from the Lithium-ion battery, never touch the fluid leak inside or outside of the vehicle. If the fluid contacts your skin or eyes, wash these areas immediately with a large amount of water and obtain immediate medical attention to help avoid serious injury.

- If a fire occurs inside your vehicle, leave the vehicle as soon as possible. Only use a type ABC, BC, or C fire extinguisher that is meant for use on electrical fires. Using a small amount of water, or the incorrect fire extinguisher can result in serious injury or death from electrical shock.
- If you are not able to safely assess the vehicle due to vehicle damage, do not touch the vehicle. Leave the vehicle and contact emergency services. Advise first responders that this is a electric vehicle.
- In the event of an accident that requires bodywork, refer to an authorized dealership.

### BATTERY CONDITIONING

In extreme temperatures, high or low, the high voltage battery may need to be conditioned, and therefore may require the vehicle to be plugged in.

If the ambient temperature is 5 °F (-15 °C) or below at vehicle shut down, the instrument cluster will display the message “Plug In Vehicle To Keep Battery Conditioned”.

If the battery temperature is below -22 °F (-30 °C), or 131 °F (55 °C) or above, the vehicle will NOT start:

- If the vehicle is plugged in at these battery temperatures, the instrument cluster will display the message “Please Leave Key In RUN — Battery Conditioning Needed”.
- If the vehicle is not plugged in at these battery temperatures, the “Plug In Vehicle To Condition Battery” will be shown in the instrument cluster display.
- If the battery temperature is below -27 °F (-33 °C), the message “Please Leave Key In RUN — Battery Conditioning Needed” will be displayed whether the vehicle is plugged in or not.

#### NOTE:

- When the “Please Leave Key In RUN — Battery Conditioning Needed” message is displayed, keep the ignition in the RUN position for the battery to recover. Place the ignition back in the OFF position when the message disappears, and then start the vehicle. When this message is displayed, do not operate any air conditioning controls.
- Under these high or low temperatures, if the vehicle is plugged in, and the ignition is in the OFF position, the vehicle may “wake up” to precondition the high voltage battery for use.
- It is recommended that the vehicle be plugged in overnight when possible to maximize the electric range of the vehicle.

The messages will only be displayed when the ignition is in the ON/RUN position and the high voltage battery is not ready to provide propulsion power. The

message also displays if there is a failed attempt to achieve READY state when the high voltage battery cell temperatures are either too cold or too hot.

## HIGH VOLTAGE CHARGING OPERATION

### SAE J1772 CHARGING INLET

Your vehicle uses an industry standard SAE J1772 charge inlet (vehicle charge inlet) for AC Level 1 (120 V), AC Level 2 (240 V), and DC Fast charge (350 V) charging.

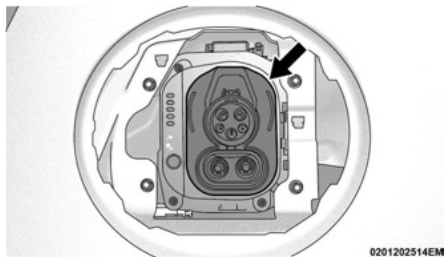

Vehicle Charge Inlet

### AC LEVEL 1 CHARGING (120 VOLT, 12 AMP) — IF EQUIPPED

Your vehicle may be equipped with a 120 Volt AC, SAE J1772 Level 1 Electric Vehicle Supply Equipment (EVSE), also referred to as a Portable Charging Cordset (EVSE). AC Level 1 charging requires a conventional NEMA 5-15R 120 Volt AC grounded wall outlet along

with the Portable Charging Cordset (EVSE) provided with the vehicle.

#### WARNING!

Please be sure to follow these warnings. Failure to do so may result in serious injury or death.

- Discontinue use of the Portable Charging Cordset (EVSE) immediately if the plug or outlet becomes hot to the touch or if you notice any unusual odors.
- Do not use the Portable Charging Cordset (EVSE) in building structures that use fuse-based circuit protection. Use only with electrical circuits protected by circuit breakers.
- Do not use the Portable Charging Cordset (EVSE) if other devices are plugged into the same circuit.
- When unplugging the Portable Charging Cordset (EVSE) from the wall outlet, be sure to pull by the plug, and not the cord.
- Do not pull, twist, bend, step on or drag the cord of the Portable Charging Cordset (EVSE).
- Stop using the Portable Charging Cordset (EVSE) immediately if charging stops before it's completed when the plug or cord is moved or adjusted.
- Do not use the Portable Charging Cordset (EVSE) if the plug has a loose connection with the wall outlet or if the wall outlet is damaged or rusted.
- If in any doubt about the wall outlet and/or circuit, contact a qualified electrician.

(Continued)

#### WARNING!

- Do not use if a malfunction occurs or if the Portable Charging Cordset has been damaged in any manner. It is recommended that you contact an authorized dealership.
- There are no user serviceable parts inside the Portable Charging Cordset (EVSE). Do not attempt to repair or service the Portable Charging Cordset (EVSE), doing so will void the New Vehicle Warranty.



0201199418US

Portable Charging Cordset (EVSE)

#### WARNING!

**INSTRUCTIONS PERTAINING TO A RISK OF FIRE OR ELECTRIC SHOCK:** Electrical shock, fire, and other serious hazards can occur if the Portable Charging Cordset (EVSE) is not used properly. This vehicle uses a high voltage current. Failure to follow the proper charging instructions in this publication can cause

(Continued)



**WARNING!**

serious injury or death. There are no serviceable parts in the Portable Charging Cordset (EVSE). Do not open, disassemble, penetrate, or tamper with the Portable Charging Cordset (EVSE). Failure to follow this warning can result in electrical shock, fire, property damage, and death or serious injury.

To access the charging cordset, remove the Level 1 (EVSE) from its storage bin by lifting the rear cargo cover.

**NOTE:**

After use, the Portable Charging Cordset (EVSE) should be placed in the storage bag and put back in the rear cargo area storage bin if equipped. If the Portable Charging Cordset (EVSE) will be left outside the vehicle, be sure to protect the connection end from moisture, dirt, and debris accumulation and contamination.

Do not use level 1 charging in case of external temperatures above 30 °C or below -20 °C as in these climatic conditions most of the power available with this type of charging will be used by the cooling/heating systems and only a small part will be used to recharge the HV battery, with a considerable increase in charging times.

**NOTE:**

The Portable Charging Cordset (EVSE) is used for AC Level 1 charging only.

**WARNING!**

**IMPORTANT SAFETY INSTRUCTIONS PERTAINING TO A RISK OF FIRE OR ELECTRIC SHOCK:** This publication contains important instructions and warnings that should be followed during charging operations. Failure to follow these warnings and instructions can result in electrical shock and fire which can cause death or serious injury.

- Read this entire publication before using the Portable Charging Cordset (EVSE).
- Do not put fingers or objects into the Portable Charging Cordset (EVSE) connector.
- Do not use the Portable Charging Cordset (EVSE) if the flexible power cord is frayed, broken, has cracked insulation, or any other signs of damage.
- Do not use the Portable Charging Cordset (EVSE) if the enclosure or the connector is broken, cracked, open, or shows any other indication of damage.
- Do not use the Portable Charging Cordset (EVSE) with an extension cord or plug adapters.
- The Portable Charging Cordset (EVSE) may attempt to reset and run after a power interruption.
- There are no user serviceable parts inside the Portable Charging Cordset (EVSE). Do not attempt to repair or service the Portable Charging Cordset (EVSE) yourself – personal injury may result.
- When using a charging station with the Portable Charging Cordset (EVSE) attached, ensure the

*(Continued)*

**WARNING!**

charging station's cable is not visibly damaged before plugging into the vehicle.

- Do not allow children to operate the Portable Charging Cordset (EVSE). Adult supervision is mandatory when children are in proximity to the charge station that is in use.
- Do not use a charge station or vehicle charge inlet that is worn or damaged with the AC Level 2 charging cable. Plugging into worn or damaged receptacles may cause damage to the Portable Charging Cordset (EVSE) and vehicle.
- Ensure that the Portable Charging Cordset (EVSE) is always stored in a safe place. Do not expose the EVSE J1772 vehicle connector to rain or wet conditions. Avoid allowing water or other liquids to pour or drip onto the vehicle connection end of the J1772 EVSE connector. If water penetrates the electrical device, the risk of electrical shock increases. Ensure that all plugs and cables are free of moisture before using the Portable Charging Cordset (EVSE).
- In a collision, a loose Portable Charging Cordset (EVSE) in the vehicle could cause injury. It could fly around in a sudden stop and strike someone in the vehicle. Do not store the Portable Charging Cordset (EVSE) on the cargo load floor, or in the passenger compartment.
- The Portable Charging Cordset (EVSE) has been tested for use in temperatures ranging from -40 °F to 122 °F (-40 °C to 50 °C).

*(Continued)*

**WARNING!**

- The Portable Charging Cordset (EVSE) should be stored at temperatures between -40°F and 176°F (-40°C and 80°C).
- SAVE THESE INSTRUCTIONS.

**EVSE Charging Cordset**

The Portable Charging Cordset (EVSE) is compliant with SAE J1772, and applicable for use with vehicles fitted with standard SAE J1772 charge inlets. The Portable Charging Cordset (EVSE) includes:

- A charge connector
- A NEMA 6 rated enclosure with a Charge Current Interrupt Device (CCID) with a status indicator display
- An AC Power Cord with a NEMA 5-15P right angle plug
- An indoor/outdoor charge cable, EV-rated
- A Status Indicator Display

**Charging Cordset**

- 1 – Charge Connector
- 2 – Status Indicator Display
- 3 – Charge Cable
- 4 – AC Plug

**GROUNDING INSTRUCTIONS****For A Grounded, Cord-Connected Product:**

The Portable Charging Cordset (EVSE) must be grounded. If it should malfunction or break down, grounding provides a path of least resistance for an electric current to reduce the risk of electric shock. The Portable Charging Cordset (EVSE) is equipped with a cord having an equipment-grounding conductor and a grounding plug. The plug must be plugged into an appropriate outlet that is properly installed and grounded in accordance with all local codes and ordinances.

**WARNING!**

**INSTRUCTIONS PERTAINING TO A RISK OF FIRE OR ELECTRIC SHOCK:** Do not use the Portable Charging Cordset (EVSE) on electrical circuits with two-prong outlets; use with improper outlets could result in electric shock, fire, property damage, and death or serious injury. Check with a qualified electrician if you are in doubt as to whether the wall outlet is properly grounded. Do not modify the plug prongs provided with the Portable Charging Cordset (EVSE) – if it does not fit the outlet, you must have a proper outlet installed by a qualified electrician.

## Charging Cordset Operation

1. Insert the AC plug prongs of the Portable Charging Cordset (EVSE) into a 15 A, or 20 A, 120 VAC, 60 Hz, grounded wall outlet. Do not use an extension cord, outlet/plug adapter, or a worn outlet. The Portable Charging Cordset (EVSE) will not operate safely unless it is plugged directly into the wall outlet.

### NOTE:

The Portable Charging Cordset (EVSE) should be plugged into a dedicated circuit, not a circuit shared with other devices drawing electricity on the circuit.

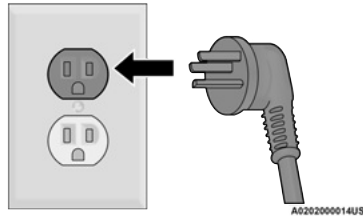

AC Plug And Wall Receptacle

### WARNING!

**INSTRUCTIONS PERTAINING TO A RISK OF FIRE OR ELECTRIC SHOCK:** Do not use the Portable Charging Cordset (EVSE) on electrical circuits with two-prong outlets; use with improper outlets

(Continued)

### WARNING!

could result in electric shock, fire, property damage, and death or serious injury. Check with a qualified electrician if you are in doubt as to whether the wall outlet is properly grounded. Do not modify the plug prongs provided with the Portable Charging Cordset (EVSE) – if it does not fit the outlet, you must have a proper outlet installed by a qualified electrician.

2. Check to see if the Portable Charging Cordset (EVSE) is ready to charge by reviewing the indicator lights. After a brief self-check, where the indicator lights will flash, a green AC Power indicator light and two green Charge Active indicator lights indicate that the Portable Charging Cordset (EVSE) is ready for use.

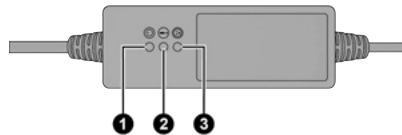

Cordset Indicator Lights

- 1 – AC Power Indicator Light
- 2 – Fault Indicator Light
- 3 – Charge Active Indicator Lights

3. If the Portable Charging Cordset (EVSE) is ready to charge, ensure the vehicle is in PARK, and then connect the charge connector to the vehicle's charge inlet. You will hear a "click" when the charge connector is inserted correctly and coupled with the vehicle's charge inlet.

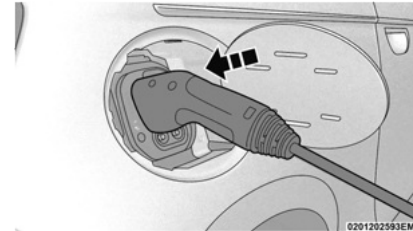

Inserting The Charge Connector Into The Vehicle Charge Inlet

4. When the vehicle commences charging, the Charge Active indicator lights on the Portable Charging Cordset (EVSE) will cycle from left to right, and then both turn off. This pattern will repeat while the vehicle is charging. The lights are illuminated at the rate of approximately one cycle per second.

### NOTE:

The vehicle should start charging automatically. If not, please check the following:

- Portable Charging Cordset (EVSE) – The Portable Charging Cordset (EVSE) status indicators illuminate green or red to identify the charging status → page 18.

- **Wall Outlet** — Check whether the wall outlet is functional (no power outage) and/or plug the Portable Charging Cordset (EVSE) into a different wall outlet.
  - **Charging Schedule** — Check whether or not the charging schedules have been enabled. If enabled, check that you are within the scheduled time and day of the week. If a charging schedule has been enabled in the vehicle, and it is outside the time and day of the week, you may override the schedule for this charging event by plugging in the charge connector, unplugging it, and then plugging it back into the vehicle charge inlet. Complete the double plug sequence within 10 seconds for it to override the set schedule.
  - **Hood Ajar** — Check whether the hood is open. Charging is disabled while the hood is open, and will resume when the hood closes.
5. To stop the charging process, disconnect the Portable Charging Cordset (EVSE) from the vehicle first, and then from the wall outlet. To disengage the vehicle coupler, push the button on the connector. The disengagement is needed to unlock the vehicle.

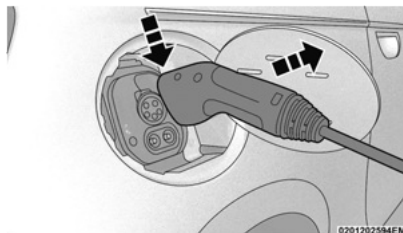

### Removing The Charge Connector From The Vehicle Charge Inlet

6. Close the inlet door when a Portable Charging Cordset (EVSE) is not connected to the vehicle.

#### NOTE:

It is good practice to keep the ignition device in OFF while conducting Level 1 charging. This minimizes any additional vehicle loads the Portable Charging Cordset (EVSE) has to support. The additional electrical loads will extend the high voltage battery charging time.

### Troubleshooting Using The Status Indicator Display

If the vehicle is not charging properly, consult the status indicator lights.

The **AC Power Indicator** displays the status and safety of the input power. If this indicator is green, the power is within acceptable limits to charge the vehicle. If only the AC Power Indicator is flashing red, then there is a problem with the AC power at the electrical outlet. If the AC Power Indicator does not return to green, then the outlet should be inspected by a qualified electrician

to ensure the voltage, frequency, and grounding are compliant to national and local electrical codes and ordinances. It may be possible to attempt charging from a different outlet.

The **Fault Indicator** displays the status of the Portable Charging Cordset (EVSE) and the vehicle connection. The Portable Charging Cordset (EVSE) will not allow charging while the fault indicator is red. If it is off, the Portable Charging Cordset (EVSE) has not detected any internal faults, or faults with the vehicle connection. If the Fault Indicator is flashing red, there is a fault detected either with the Portable Charging Cordset (EVSE), electronics, or with the vehicle connection. The Portable Charging Cordset (EVSE) may attempt to retry to provide current to the vehicle if the fault is cleared. If the Portable Charging Cordset (EVSE) does not attempt to provide charge to the vehicle, the charge connector will need to be removed from the vehicle to clear the fault.

The fault code list in the following table provides a reference for the important faults that are detected by the Portable Charging Cordset (EVSE). When a fault is detected, the AC Power Indicator, the Fault Indicator, or both the AC Power and Fault Indicators will flash red. If only the AC Power Indicator is red, there is a problem on the AC Power side of the unit. If only the Fault Indicator is flashing red, there is a problem internal to the unit or with the vehicle. If both the AC Power and Fault Indicators are flashing red, an over temperature condition is detected at either the AC plug or within the Portable Charging Cordset (EVSE) enclosure. Additional information about the faults is provided by a fault code that is displayed on the two green Charge Active Indicators. The fault code consists of four digits, each with a value of 1 or 2. The value of

a digit is the number of indicators illuminated for that part of the sequence. For example, fault code (1, 2, 1, 1) will display the following sequence: One indicator will illuminate for 0.3 seconds, then two indicators will illuminate, then one indicator, and finally one indicator will illuminate. After all four fault code digits have been displayed, the indicators will remain off for one second before repeating the sequence.

Portable Charging Cordset (EVSE) Fault Code List			
Flashing Fault Code	Flashing Indicator	Fault Indication	Recommended Actions
1, 2, 2, 2	AC Power	Vehicle Current Draw is Too High	Check Portable Charging Cordset (EVSE) and vehicle at an authorized dealership.
1, 1, 2, 1	AC Power	Incorrect Electrical Supply	Attempt to charge the vehicle at a different outlet. Contact a qualified electrician to check the electrical outlet and AC Supply (house wiring).
1, 1, 2, 2	AC Power	Incorrect Electrical Supply	Attempt to charge the vehicle at a different outlet. Contact a qualified electrician to check the electrical outlet and AC Supply (house wiring).
1, 2, 1, 1	AC Power	Incorrect Electrical Supply	Attempt to charge the vehicle at a different outlet. Contact a qualified electrician to check the electrical outlet and AC Supply (house wiring).
1, 2, 1, 2	AC Power	Incorrect Electrical Supply	Attempt to charge the vehicle at a different outlet. Contact a qualified electrician to check the electrical outlet and AC Supply (house wiring).
1, 1, 1, 1	Fault	Portable Charging Cordset (EVSE) Internal Fault	Unplug the Portable Charging Cordset (EVSE) from the vehicle charge inlet and retry to charge. If the issue is not corrected, check the Portable Charging Cordset (EVSE) and vehicle at an authorized dealership.
1, 1, 1, 2	Fault	Portable Charging Cordset (EVSE) Internal Fault	Unplug the Portable Charging Cordset (EVSE) from the vehicle charge inlet and retry to charge. If the issue is not corrected, check the Portable Charging Cordset (EVSE) and vehicle at an authorized dealership.
1, 2, 2, 1	AC Power	Outlet Wiring Bad Ground	Attempt to charge the vehicle at a different outlet. Contact a qualified electrician to check the electrical outlet and AC Supply (house wiring).
1, 2, 1, 1	Fault	Portable Charging Cordset (EVSE) Internal Fault	Check the Portable Charging Cordset (EVSE) and vehicle at an authorized dealership.
1, 2, 1, 2	Fault	CCID Leakage Current Detected	Disconnect charge connector and retry charging. If problem persists, check the Portable Charging Cordset (EVSE) and vehicle at an authorized dealership.
2, 2, 2, 1	Fault	Vehicle Interface Connector	Error with the Vehicle Charge Connector Interface — Check for water or other contamination in the vehicle charge inlet or charge connector.
2, 2, 2, 2	Fault	Vehicle Interface Connector	Error with the Vehicle Charge Connector Interface — Check for water or other contamination in the vehicle charge inlet or charge connector.
1, 1, 2, 1	Fault & AC Power	Portable Charging Cordset (EVSE) Enclosure Internal Temperature is Too High	Use caution as the Portable Charging Cordset (EVSE) housing may be hot. It is recommended to move the Portable Charging Cordset (EVSE) out of direct sun exposure. Allow the unit to cool. If error persists, check the Portable Charging Cordset (EVSE) at an authorized dealer.

Portable Charging Cordset (EVSE) Fault Code List			
Flashing Fault Code	Flashing Indicator	Fault Indication	Recommended Actions
1, 1, 1, 2	Fault & AC Power	Hot AC Power Plug Warning	Use caution as the Portable Charging Cordset (EVSE) AC Power Plug may be hot. It is recommended to carefully unplug the unit from the wall outlet and allow it to cool down. Attempt to charge the vehicle at a different wall outlet. Contact a qualified electrician to inspect/replace the wall outlet that was associated with the Hot AC Plug event. Charging will still occur, but at a reduced rate.
1, 1, 1, 1	Fault & AC Power	AC Power Plug Over Temperature	Use caution as the Portable Charging Cordset (EVSE) AC Power Plug may be hot. It is recommended to carefully unplug the unit from the wall outlet and allow it to cool down. Attempt to charge the vehicle at a different outlet. Contact a qualified electrician to inspect/replace the outlet that was associated with the Hot AC Plug event.

## FCC Notice:

This unit has systems that operate on a radio frequency that comply with Part 15 of the Federal Communications Commission (FCC) rules.

Operation is subject to the following two conditions:

1. The device may not cause interference.
2. The device must accept any interference received, including interference that may cause undesired operation of the device.

Changes or modifications to any of these systems by other than an authorized service facility could void authorization to use this equipment.

This unit complies with ICES-003E of Industry Canada, and EMC Directive 2004/108/EC.

## Guidelines for preventing fire and electric shock:

- Ensure the Portable Charging Cordset (EVSE) is positioned so it will not be stepped on, tripped over, or otherwise subjected to damage or stress.
- There are no user serviceable parts inside.
- Do not use the Portable Charging Cordset (EVSE) if it is visibly damaged. Contact an authorized dealership for service.
- Do not place fingers, or any other objects inside the charge connector.
- Do not allow children to operate the Portable Charging Cordset (EVSE). Adult supervision is mandatory when children are in proximity when the Portable Charging Cordset (EVSE) is in use.
- Do not use the Portable Charging Cordset (EVSE) with an extension cord or plug adapters.
- Do not unplug the Portable Charging Cordset (EVSE) from the wall outlet during a charging operation.

**NOTE:**

During normal operation, the charge connector or AC plug may feel warm. If either one feels hot during charging, unplug the Portable Charging Cordset (EVSE) and have a qualified electrician inspect the wall outlet before you continue charging ➡ page 211.

**WARNING!**

**INSTRUCTIONS PERTAINING TO A RISK OF FIRE OR ELECTRIC SHOCK:** Do not use the Portable Charging Cordset (EVSE) with an outlet that is worn or damaged. Failure to follow this warning can result in electrical shock, fire, property damage, and death or serious injury.

## AC LEVEL 2 CHARGING (240 VOLT, 32 AMP)

AC Level 2 (240 V) charging requires a 240 V, Level 2 Electric Vehicle Supply Equipment (EVSE) charging station. A 32 Amp Level 2 EVSE for home installation

is recommended. The Level 2 EVSE connects to a 40 Amp circuit breaker and delivers 32 Amp maximum to the vehicle.

When using public charging stations, ensure the charging station is ready to provide charge and the vehicle is in PARK before the Level 2 EVSE is plugged into the vehicle's charge inlet. You will hear a "click" when the charge connector is inserted correctly and is coupled with the vehicle's charge inlet.

**NOTE:**

The vehicle should start charging automatically. If not, please check the following:

- **Charging Station** — Check the indications and instructions at the charging station.
- **Charging Schedule** — Check whether the charging schedule is enabled and if so, whether the vehicle is currently within the scheduled charge time/day (weekday/weekend). If the charging schedule is enabled within the vehicle, you may override it for this charging event by plugging in the charge connector, unplugging it, and then plugging it back into the vehicle charge inlet. Complete the double plug sequence within 10 seconds for it to override the set schedule.
- **Hood Ajar** — Check whether the hood is open. Charging is disabled while the hood is open, and will resume when the hood closes.

To stop the charging process:

- Press the button located on the Level 2 EVSE vehicle connector.
- Remove the connector from the vehicle charge inlet.

- Plug the charge handle into the Level 2 EVSE station and coil the charging cord onto its holder. Do not leave the charging cord lying on the ground.

## DC CHARGING

DC Charging is a significantly faster method of charging your vehicle either on the go or overnight. The DC charging cable plugs into the vehicle straight from the power outlet not needing the status indicator display. The power converter for the DC charging cord is within the charging cable.

When using public charging stations, ensure the charging station is ready to provide charge and the vehicle is in PARK before the charging cable is plugged into the vehicle's charge inlet. You will hear a "click" when the charge connector is inserted correctly and is coupled with the vehicle's charge inlet.

**NOTE:**

DC Charging can vary from high to low power depending on potential external factors such as weather and power supply.

**NOTE:**

Due to the convenience of DC Charging there may be a higher payment required depending on the charge station selected.

**NOTE:**

The vehicle should start charging automatically. If not, please check the following:

- **Charging Station** — Check the indications and instructions at the charging station.

- **Charging Schedule** — Check whether the charging schedule is enabled and if so, whether the vehicle is currently within the scheduled charge time/day (weekday/weekend). If the charging schedule is enabled within the vehicle, you may override it for this charging event by plugging in the charge connector, unplugging it, and then plugging it back into the vehicle charge inlet. Complete the double plug sequence within 10 seconds for it to override the set schedule.
- **Hood Ajar** — Check whether the hood is open. Charging is disabled while the hood is open, and will resume when the hood closes.

## VEHICLE CHARGE INDICATORS

### Instrument Cluster High Voltage Battery Display

There is a battery display indicator located on the instrument cluster. The battery display will indicate the current State Of Charge (SOC) for the high voltage battery; with the percentage value located to the top of the bar. When plugged in, the battery symbol also indicates the battery level along with messages about the charge or whether the system is waiting to charge due to the charge schedule. These will appear unless there is a charging fault. A green plug telltale will be shown in the cluster, as well as applicable messaging when charging.

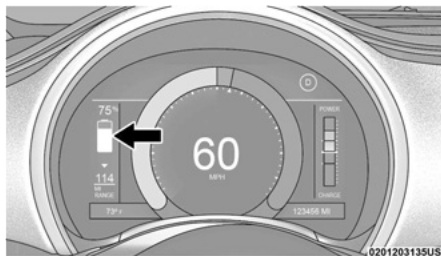

**High Voltage Battery Display**

#### Instrument Panel State Of Charge Indicator

In addition to the battery display in the instrument cluster, your vehicle is equipped with a visual SOC indicator. The SOC indicator is made up of five lights

that are mounted to the left of the charge port, which will illuminate when the vehicle is plugged into the charging system.

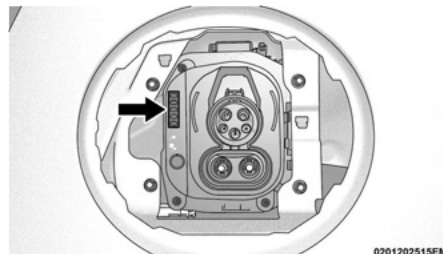

**Charge Port SOC Indicator**

The SOC indicator provides a visual indication of the high voltage battery's charge status during charging. It is also used to indicate a charging problem as well as waiting for a scheduled charge to begin.

#### **NOTE:**

The lights scroll one at a time when the vehicle is plugged in outside of its charging schedule time/day of the week, and it is waiting on the schedule to begin charging.

In extreme hot or cold environments, the lights on the SOC indicator may not illuminate. Charge status is available in the instrument cluster display. In the event of an error in the charging process, the outer two lights will blink.

When the hood is open, the lights on the SOC indicator will not be illuminated.

Number Of Indicator Lights Illuminated	Percent Of Battery Charge
1st light blinks	0 - 20%
1st light on, 2nd light blinks	21 - 40%
1st and 2nd lights on, 3rd light blinks	41 - 60%
1st, 2nd, and 3rd lights on, 4th light blinks	61 - 80%
1st, 2nd, 3rd, and 4th lights on, 5th light blinks	81 - 99%
All 5 lights on	100%
Two outer lights are blinking	Indicates an error in the charging process
Lights turn on one at a time from left to right (when looking at the front of the vehicle)	Indicates system is waiting for scheduled time in charge schedule to begin charging
All lights turn on, then immediately turn off	Indicates a successful plug-in

#### **NOTE:**

For each segment of lights illuminated indicating the percent of battery charge, two different blink rates are used. A blink rate of 1 second on/1 second off indicates that the first half is charging. The blink rate will increase to 0.5 second on/0.5 second off to indicate that the second half is charging. When the battery is fully charged, the blinking stops and the lights remain illuminated as charging continues.



## ELECTRIC VEHICLE APP

Within the Uconnect system is the Electric Vehicle App that allows you to see your vehicle's power flow and set a charging schedule for your vehicle's high voltage battery. To access this App, press the Apps or Vehicle button on the main menu bar of the radio's touchscreen, and locate the Electric Vehicle App. Accessing the app brings you to a set of three pages: Power Flow, Schedules, and Charge Setting.

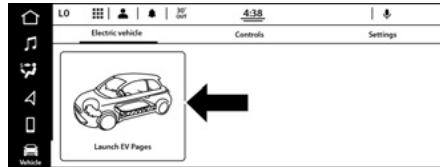

Electric Vehicle App Location

### Power Flow

The Power Flow screen shows the current power readings for all of the following:

- Motor - Shows the amount of power (in kW) the high voltage battery is currently providing/absorbing.
- Climate - Shows the amount of power (in kW) the Climate Control system is using to maintain the current interior temperature.

Power Flow paths are indicated by the direction of the arrows on the touchscreen.

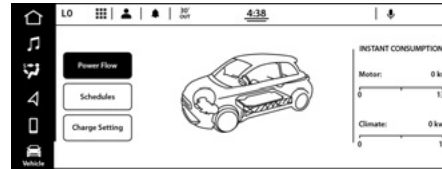

Power Flow Screen

### Driving History

The Driving History screen shows the miles (km) driven in Full Electric kWh (battery powered) mode for both the previous week and the current week. The data is displayed in a bar graph: Electric mode in teal.

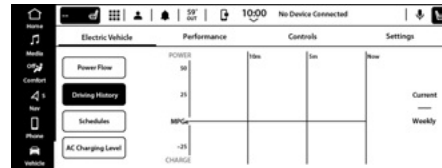

Driving History Screen

### Charging Schedule

To set a charging schedule, select the Electric Vehicle App in the touchscreen and follow these steps:

1. Select "Schedules".

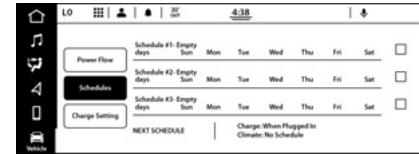

Schedules Screen

2. Select the schedule to be set (1, 2, or 3) by pressing the appropriate arrow on the right side of the screen.
3. Select what time Scheduled Charging should start and stop charging or select "Charge Until Full". If "Charge Until Full" is selected a stop charging time cannot be selected.
4. Set the Charge Start Time: Hours, Minutes, and AM/PM.

#### NOTE:

This is to occur every week (as long as the vehicle is connected to an EVSE).

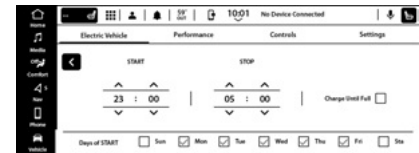

Set Charge Schedule

- When done, press the Back Arrow in the upper right hand corner, then select “yes” to save the charge schedule. The active schedule will be indicated by the check mark to the right of the schedule event line. The event action and time will be displayed.
- To add another Scheduled Charging event, repeat these steps.

**NOTE:**

A maximum of three independent Scheduled Charging events can be scheduled at a given time.

**NOTE:**

- If the charging schedule is not enabled, the vehicle will charge whenever plugged in. It is not necessary to set up the charging schedule to charge the vehicle.
- If the vehicle is plugged in outside of the charging schedule set in the Uconnect system (and Charge Until Full is not selected), the vehicle’s battery will not charge. Charging will only begin immediately if the vehicle is plugged in within the time and day of the week set in the schedule. Otherwise, charging will automatically begin when the selected charge time/day of the week occurs or whenever the vehicle is plugged in with no charge schedule set.
- If the vehicle is turned off outside of the charging window, a radio pop-up message will be displayed, which provides an option to begin charging the vehicle immediately. The pop-up message asks the driver if they would like to “Charge Now?” and provides other information, including the next

charging schedule start time and estimated time to charge the battery to 100%. If within one hour of selecting “Yes,” the vehicle is connected to a powered EVSE, the vehicle will immediately begin to charge (temporarily ignoring any set charge schedule). To fully deactivate the charge schedule, refer to the “Schedules” feature within the Electric Vehicle App.

- The charging schedule can also be overridden if an EVSE is plugged in, unplugged, and then plugged in a second time to the vehicle. This “double plug sequence” will override the schedule that is set in the radio, and begin charging the vehicle immediately. The double plug sequence must be completed within 10 seconds for it to override the programmed schedule.
- If “Charge Until Full” is selected, and the vehicle is plugged in after the start time of the schedule, the vehicle will start charging when it reaches the start time the next day. If you would like to begin charging immediately, and continue charging until the vehicle is fully charged, you can select the “Charge Now” option or use the double plug override option.

**NOTE:**

For information on jump starting your vehicle, ⇨ page 173.

**AC Charging Level— If Equipped**

The fourth screen within the Electric Pages App is the AC Charging Level screen. From this screen, you can select the rate at which your vehicle charges. Rate selections 1 (low rate of charge) through 5 (high rate of charge) are available. The lower the selected rate, the longer it will take for your vehicle to reach a full charge.

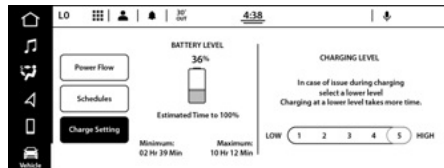
**Charge Setting Screen**

The Charge Setting can be adjusted by selecting one of the levels 1 through 5, with 1 being the slowest rate of charge and 5 being the fastest. The display also shows information related to:

- Battery Level — Indicates, in percentage, the high-voltage battery SOC.
- Estimate time to 100% — Corresponds to the time required to obtain full recharging of the high-voltage battery.

**NOTE:**

- The Charge Setting will be saved each time the vehicle is turned off, then back on again.
- For information on jump starting your vehicle ⇨ page 173.

**KEYS****KEY FOB**

Your vehicle is equipped with a key fob which supports Passive Entry, Remote Keyless Entry (RKE) and Keyless Enter 'n Go™. The key fob allows you to lock or unlock

the doors and liftgate or activate the Panic Alarm from distances up to approximately 66 ft (20 m). In some conditions, this distance can be reduced or increased. The key fob does not need to be pointed at the vehicle to activate the system. The key fob also contains an emergency key, which is stored inside the key fob.

#### NOTE:

- The key fob's wireless signal may be blocked if the key fob is located next to a metallic object, mobile phone, laptop, wireless charging pad, or other electronic device. This may result in poor performance.
- If the key fob's battery is near depletion, the key fob performance can be reduced.

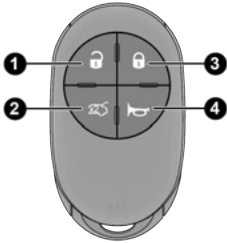

Keyless Ignition Key Fob

- 1 — Unlock
- 2 — Liftgate
- 3 — Lock
- 4 — PANIC

In case the ignition switch does not change with the push of a button, the key fob may have a low or fully depleted battery. A low key fob battery can be verified by referring to the instrument cluster, which will display directions to follow ⇨ page 211.

### To Unlock/Lock The Doors And Liftgate

Push and release the unlock button on the key fob once to unlock the driver's door, or twice within five seconds to unlock all the doors and the liftgate. To lock all the doors and the liftgate, push the lock button once.

When the doors are unlocked, the turn signals will flash and the illuminated entry system will be activated. When the doors are locked, the turn signals will flash and the horn will chirp (if programmed in the Uconnect system).

#### NOTE:

If the vehicle is unlocked by a key fob, and no door is opened within 60 seconds, the vehicle will relock and if equipped, the security system will arm.

All doors can be programmed to unlock on the first push of the unlock button within Uconnect Settings ⇨ page 113.

### Key Left Vehicle Feature — If Equipped

If a valid key fob is no longer detected inside the vehicle while the vehicle's ignition system is in the ON/RUN position, the message "Key Fob Has Left The Vehicle" will be shown in the instrument cluster display along with an interior chime. An exterior audible and visual alert will also be activated to warn the driver.

The vehicle's horn will rapidly chirp three times along with a single flash of the vehicle's exterior lights.

#### NOTE:

- The doors have to be open and then closed in order for the vehicle to detect a key fob; the Key Left Vehicle feature will activate when the first door is closed and no key fob is detected in the vehicle. If the warning has been activated, and the other doors are closed, no other warnings will be issued.
- These alerts will not be activated in situations where either the vehicle's engine is left running with the key fob inside, or the key fob's wireless signals are blocked.

### Replacing The Battery In The Key Fob

The recommended replacement battery is one CR2032 battery.

#### NOTE:

- Customers are recommended to use a battery obtained from Mopar®. Aftermarket coin battery dimensions may not meet the original OEM coin battery dimensions.
- Perchlorate Material — special handling may apply. See [www.dtsc.ca.gov/hazardouswaste/perchlorate](http://www.dtsc.ca.gov/hazardouswaste/perchlorate) for further information.
- Do not touch the battery terminals that are on the back housing or the printed circuit board.

To replace the battery, proceed as follows:

- Using the fingertips, move the cover in the direction of the key chain hole until the teeth are released; gently remove the lower cover by pulling it upwards.

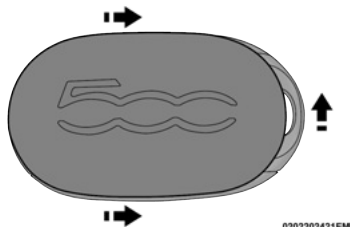

Key Fob Cover Removal

- Remove the emergency key from its housing.



Emergency Key Removal

- Remove the battery cover by prying the recess upwards.

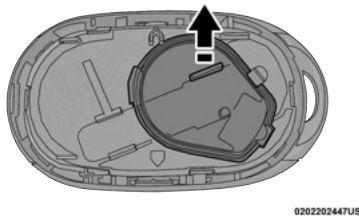

Removing Battery Cover

- Remove the battery from its slot and replace it with a new one. When replacing the battery, match the (+) sign on the battery to the (+) sign on the inside of the battery clip, located on the back cover. Avoid touching the new battery with your fingers. Skin and oils may cause battery deterioration. If you touch a battery, clean it with rubbing alcohol.

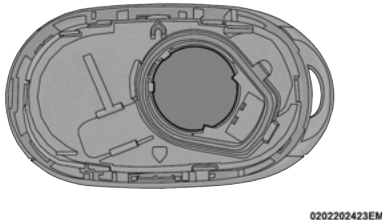

Battery Location

Proceed in reverse order to reassemble the key.

#### WARNING!

- The integrated key fob contains a coin cell battery. Do not ingest the battery; there is a chemical burn hazard. If the coin cell battery is swallowed, it can cause severe internal burns in just two hours and can lead to death.
- If you think a battery may have been swallowed or placed inside any part of the body, seek immediate medical attention.
- Keep new and used batteries away from children. If the battery compartment does not close securely, stop using the product and keep it away from children.

#### Programming And Requesting Additional Key Fobs

Programming the key fob may be performed by an authorized dealer.

#### NOTE:

- Once a key fob is programmed to a vehicle, it cannot be repurposed and reprogrammed to another vehicle.
- Only key fobs that are programmed to the vehicle electronics can be used to start and operate the vehicle.

**WARNING!**

- Always remove the key fobs from the vehicle and lock all doors when leaving the vehicle unattended.
- For vehicles equipped with Keyless Enter 'n Go™ Ignition, always remember to place the ignition in the OFF position when exiting the vehicle.

Duplication of key fobs may be performed at an authorized dealer. This procedure consists of programming a blank key fob to the vehicle electronics. A blank key fob is one that has never been programmed.

**NOTE:**

- When having the Sentry Key Immobilizer system serviced, bring all vehicle keys with you to an authorized dealer.
- Emergency keys must be ordered to the correct key cut to match the vehicle locks.
- It is not mandatory to replace the key fob if a new emergency key is needed, and vice versa.

**SENTRY KEY**

The Sentry Key Immobilizer System prevents unauthorized vehicle operation by disabling the vehicle. The system does not need to be armed or activated. Operation is automatic, regardless of whether the vehicle is locked or unlocked.

The system uses a key fob, keyless push button ignition and a Radio Frequency (RF) receiver to prevent

unauthorized vehicle operation. Therefore, only key fobs that are programmed to the vehicle can be used to start and operate the vehicle. The system will shut the engine off in two seconds if an invalid key fob is used to start the engine.

**NOTE:**

A key which has not been programmed is also considered an invalid key, even if it is cut to fit the ignition switch lock cylinder for that vehicle.

If the Vehicle Security Light turns on during normal vehicle operation (vehicle running for longer than 10 seconds), it indicates that there is a fault in the electronics. Should this occur, have the vehicle serviced as soon as possible by an authorized dealer.

**CAUTION!**

- Always remove the Sentry Key from the vehicle and lock all doors when leaving the vehicle unattended.
- The Sentry Key Immobilizer system is not compatible with some aftermarket remote starting systems. Use of these systems may result in vehicle starting problems and loss of security protection.

All of the keys provided with your new vehicle have been programmed to the vehicle electronics.

**IGNITION SWITCH****KEYLESS ENTER 'N GO™ IGNITION**

This feature allows the driver to operate the ignition switch with the push of a button as long as the key fob is in the passenger compartment.

The START/STOP ignition button has three operating positions. These positions are OFF, ON, and RUN.

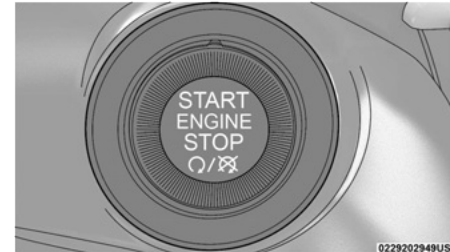
**START/STOP Ignition Button**

The push button ignition can be placed in the following positions:

**OFF**

- The engine is stopped.
- No electrical devices are available.

**ON**

- The vehicle is not running.
- Some electrical devices (power locks, alarm, etc.) are still available.

**RUN**

- Driving mode.
- All electrical devices are available (e.g. climate controls, heated seats, etc.).

**NOTE:**

The vehicle will not start if the key fob is located inside the cargo area and the liftgate is opened.

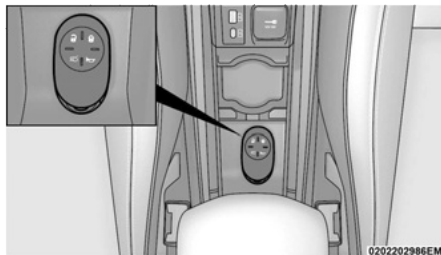
**Backup Starting Method****NOTE:**

If the ignition switch does not change with the push of a button, the key fob may have a low or depleted battery. In this situation, a backup method can be used to operate the ignition switch. Put the key fob in the cup holder between the front seats, in the dedicated spot with a symbol and push to operate the ignition switch.

**WARNING!**

- When exiting the vehicle, always remove the key fob from the vehicle and lock your vehicle.
- Never leave children alone in a vehicle, or with access to an unlocked vehicle.
- Allowing children to be in a vehicle unattended is dangerous for a number of reasons. A child or others could be seriously or fatally injured. Children should be warned not to touch the parking brake, brake pedal or the gear selector.
- Do not leave the key fob in or near the vehicle, or in a location accessible to children, and do not leave the Keyless Enter 'n Go™ Ignition in the ON/RUN position. A child could operate power windows, other controls, or move the vehicle.
- Do not leave children or animals inside parked vehicles in hot weather. Interior heat buildup may cause serious injury or death.

**CAUTION!**

An unlocked vehicle is an invitation for thieves. Always remove key fob from the vehicle and lock all doors when leaving the vehicle unattended.

**NOTE:**

- The key fob may not be detected by the vehicle Keyless Enter 'n Go™ system if it is located next to a mobile phone, laptop or other electronic device; these devices may block the key fob's wireless signal and prevent the Keyless Enter 'n Go™ system from starting the vehicle.

- For more information on normal engine starting, see  page 70.
- When opening the driver's door and the ignition is in the ON/RUN position (engine not running), a chime will sound to remind you to place the ignition in the OFF position. In addition to the chime, the message "Ignition ON" will display in the cluster.
- The ignition will automatically switch to the OFF position if the following vehicle conditions last for 30 minutes: ignition placed in the ON/RUN position, gear is in PARK and engine is off.

**DOORS****POWER DOOR LOCKS**

The power lock/unlock button has an LED that indicates whether the doors are locked or unlocked.

Push the lock button on the instrument panel. The indicator light will illuminate to show the doors are locked.

Push the lock button on the instrument panel a second time to unlock the doors.

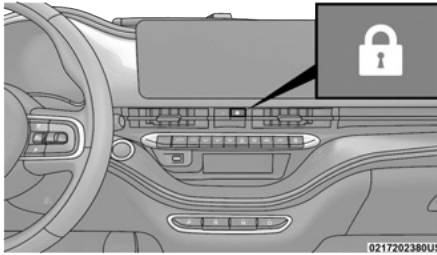

### Instrument Panel Lock Button

- **LED ON:** Doors locked. Push the central lock/unlock button once to centrally unlock the front doors and liftgate. The LED will switch off.
- **LED OFF:** Doors unlocked. Push the central lock/unlock button again to centrally lock the front doors and liftgate. The doors will be locked only if all the doors are properly closed.

### WARNING!

- When exiting the vehicle, always remove the key fob from the vehicle and lock your vehicle.
- Never leave children alone in a vehicle, or with access to an unlocked vehicle.
- Allowing children to be in a vehicle unattended is dangerous for a number of reasons. A child or others could be seriously or fatally injured. Children should be warned not to touch the parking brake, brake pedal or the gear selector.

(Continued)

### WARNING!

- Do not leave the key fob in or near the vehicle, or in a location accessible to children, and do not leave the ignition of a vehicle equipped with Keyless Enter-N-Go in the ON/RUN mode. A child could operate power windows, other controls, or move the vehicle.
- Do not leave children or animals inside parked vehicles in hot weather. Interior heat build-up may cause serious injury or death.

### CAUTION!

An unlocked car is an invitation. Always remove the key from the vehicle and lock all doors when leaving the vehicle unattended.

## DOOR OPENING

The door can be opened by pressing the button located above each front door panel. If all doors are locked, pressing the button on either door will unlock the other door and liftgate. This ability can be activated or deactivated via Uconnect Settings ➞ page 113.

### NOTE:

Press the button three times in two seconds to open the doors in motion at speeds above 3 mph (5 km/h). Below 3 mph (5 km/h) doors will open at first press.

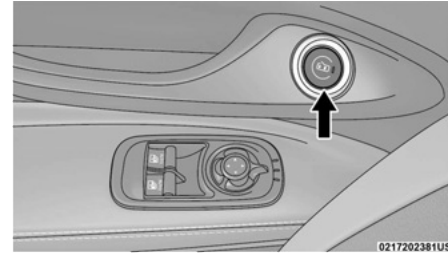

### Power Door Button Opening

The doors can also be locked and unlocked with the Keyless Enter 'n Go - Passive Entry system.

### NOTE:

If the electronic key does not work, the doors can still be opened from the inside by pulling the manual door handle. For information on how to use the manual door handle, see ➞ page 31.

## KEYLESS ENTER 'N GO™ — PASSIVE ENTRY

The Passive Entry system is an enhancement to the vehicle's Remote Keyless Entry system and a feature of Keyless Enter 'n Go™. This feature allows you to lock and unlock the vehicle's door(s) without having to push the key fob lock or unlock buttons.

### NOTE:

- Passive Entry may be programmed on/off through Uconnect Settings ➞ page 113.

- The key fob may not be detected by the vehicle Passive Entry system if it is located next to a mobile phone, laptop, or other electronic device; these devices may interfere with the key fob's wireless signal and prevent the Passive Entry system from locking and unlocking the vehicle.
- If wearing gloves, if it has been raining/snowing, or there is salt/dirt covering the Passive Entry door handle, the unlock sensitivity can be affected, resulting in a slower response time.
- The doors may unlock when water is sprayed on the Passive Entry door handles if the key fob is located outside of the vehicle within 5 ft (1.5 m) of the handle.
- If the vehicle is unlocked by the Passive Entry door handle, and no door opens within 60 seconds, the vehicle will relock and if equipped, the Vehicle Security system will arm.

#### To Unlock From The Driver Side

With a valid Passive Entry key fob within 5 ft (1.5 m) of the door handle, grab the handle to unlock the vehicle. Grabbing the driver's door handle will unlock all doors and the liftgate automatically.

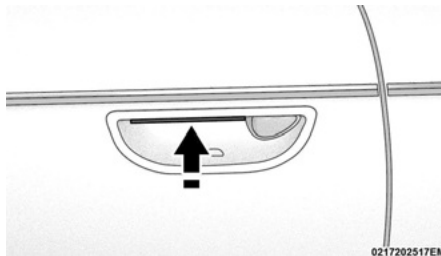

#### Lift The Door Handle To Unlock

#### NOTE:

- Either the driver door only or all doors will unlock when you grab hold of the front driver's door handle, depending on the selected setting in the Uconnect system → page 113.

#### Frequency Operated Button Integrated Key (FOBIK-Safe)

To minimize the possibility of unintentionally locking a Passive Entry key fob inside your vehicle, the Passive Entry system is equipped with an automatic door unlock feature.

FOBIK-Safe only executes in vehicles with Passive Entry. There are three situations that trigger a FOBIK-Safe search in any Passive Entry vehicle:

- A lock request is made by a valid Passive Entry key fob while a door is ajar.
- A lock request is made by the Passive Entry door handle while a door is ajar.
- A lock request is made by the door panel switch while the door is ajar.

When any of these situations occur, after all ajar doors are shut, the FOBIK-Safe search will be executed. If it detects a Passive Entry key fob inside the car, and it does not detect any Passive Entry key fobs outside the car, then the car will unlock and alert the customer.

#### NOTE:

The vehicle will only unlock the doors when a valid Passive Entry key fob is detected inside the vehicle, and no valid Passive Entry key fob is detected outside the vehicle. The vehicle will not unlock the doors when any of the following conditions are met:

- The doors are manually locked using the door lock button.
- There is a valid Passive Entry key fob outside the vehicle and within 5 ft (1.5 m) of either Passive Entry door handle.

#### To Lock The Vehicle's Doors And Liftgate

With one of the vehicle's Passive Entry key fobs within 5 ft (1.5 m) of either front door handles, pushing the Passive Entry lock button will lock the vehicle.



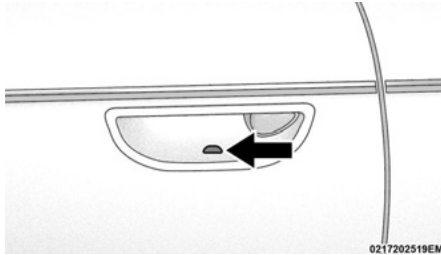

### Push The Door Handle Button To Lock

#### NOTE:

- After pushing the door handle button, you must wait two seconds before you can lock or unlock the doors, using any Passive Entry door handle. This is to allow you to check if the vehicle is locked by pulling the door handle without the vehicle unlocking.
- The Passive Entry system will not operate if the key fob battery is depleted.

The vehicle doors can also be locked by using the lock button located on the center dashboard.

#### Activation/Deactivation Of Keyless Enter 'n Go™

Keyless Enter 'n Go™ can be activated or deactivated through the instrument cluster display or through the Uconnect system ⇨ page 211.

## AUTOMATIC DOOR LOCKS — IF EQUIPPED

When the auto door lock feature is enabled, if all of the doors are closed properly, the door locks will lock automatically when the vehicle's speed exceeds 12

mph (20 km/h). The auto door lock feature is enabled/disabled within Uconnect Settings ⇨ page 113.

## EMERGENCY CLOSING AND OPENING

If the electronic key does not work, e.g. if the battery of the key is low, you can:

- Unlock the car using the mechanical key inside the electronic key by acting on the pawl located on the driver's door. See the "Emergency opening of the doors from outside" paragraph below.
- Lock the car by pressing the door open button placed on the inner door panel for about 5 seconds keeping the ignition device in OFF position and the door open. The car will lock all the doors and the liftgate after about 5 seconds. The LED on the door button and on the center dashboard will light up to notify the locking. When the last door is closed the car will be locked. The car can be locked from any door, respecting the manoeuvre described above.

#### NOTE:

After locking the car by emergency manoeuvre, make sure you do not leave the keys inside the car. The emergency locking manoeuvre disables the FOB/IK-Safe function.

#### Opening And Locking Doors In The Event Of Power Failure

In the event of a flat 12V car battery, the doors can still be opened or locked because they are equipped with an additional power supply.

## Opening and Locking Doors in the Event of Power Failure

If the 12V battery of the car is flat, the doors can still be opened or locked as they are equipped with an additional power supply.

#### Opening the doors

You can open the door in the following ways:

- with the doors locked, press the door opening button on the external handle three times within 2 seconds.
- Turn the pawl placed on the driver's door using the mechanical key located inside the electronic key.
- Press the internal door opening button three times in two seconds.

#### Locking the doors

The doors can be locked following the emergency locking manoeuvre. See the "Emergency closing and opening" paragraph described above.

#### NOTE:

If the doors are not locked using the emergency locking procedure, repeat the operation for each single door.

#### RESET

Resetting the door is automatic for a certain number of times after which it must be done manually using the pawl using the key inside the remote control.

**Door RESET****Emergency opening of the doors from the inside**

If the electronic key does not work, for example if the electronic key or the 12V battery of the car is low, the doors can still be opened from the inside by pulling the manual door handle located on each door.

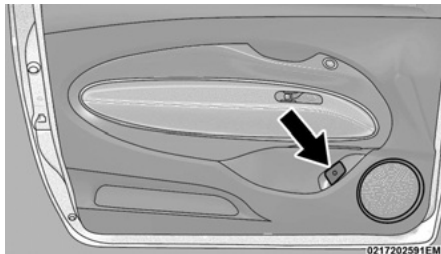
**Manual Door Handle****Emergency opening of the doors from the outside**

If the electronic key does not work (e.g. if the battery of the electronic key is low) or if the power supply fails completely, you can still open the doors from the outside by proceeding as follows:

- remove the cap present on the external handle on the driver's side inserting the mechanical key inside the electronic key in the slot;

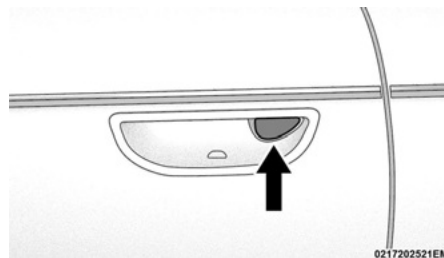
**External Handle Cap**

- open the door using the mechanical key inside the electronic key by turning the pawl anticlockwise on the outside handle on the driver's side.

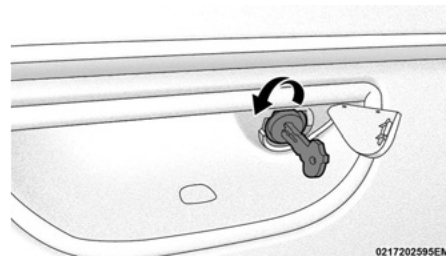
**Mechanical Key Opening****STEERING WHEEL****MANUAL TILT/TELESCOPING STEERING COLUMN**

This feature allows you to tilt the steering column upward or downward. It also allows you to lengthen or shorten the steering column. The tilt/telescoping lever is located below the steering wheel at the end of the steering column.

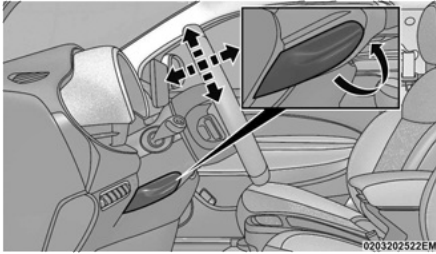

### Tilt/Telescoping Lever

To unlock the steering column, push the tilt/telescoping lever downward (toward the floor). To tilt the steering column, move the steering wheel upward or downward as desired. To lengthen or shorten the steering column, pull the steering wheel outward or push it inward as desired.

To lock the steering column in position, pull the tilt/telescoping lever upward until fully engaged.

#### WARNING!

Do not adjust the steering column while driving. Adjusting the steering column while driving or driving with the steering column unlocked, could cause the driver to lose control of the vehicle. Failure to follow this warning may result in serious injury or death.

## SEATS

Seats are a part of the Occupant Restraint system of the vehicle.

#### WARNING!

- It is dangerous to ride in a cargo area, inside or outside of a vehicle. In a collision, people riding in these areas are more likely to be seriously injured or killed.
- Do not allow people to ride in any area of your vehicle that is not equipped with seats and seat belts. In a collision, people riding in these areas are more likely to be seriously injured or killed.
- Be sure everyone in your vehicle is in a seat and using a seat belt properly.

## MANUAL ADJUSTMENT (FRONT SEATS)

#### WARNING!

- Adjusting a seat while the vehicle is moving is dangerous. The sudden movement of the seat could cause you to lose control. The seat belt might not be adjusted properly and you could be injured. Adjust the seat only while the vehicle is parked.
- Do not ride with the seatback reclined so that the shoulder belt is no longer resting against your chest. In a collision you could slide under the seat belt and be seriously or even fatally injured. Use the recliner only when the vehicle is parked.

## Manual Front Seat Forward/Rearward Adjustment

The seat can be adjusted forward or rearward by using a bar located by the front of the seat cushion, near the floor.

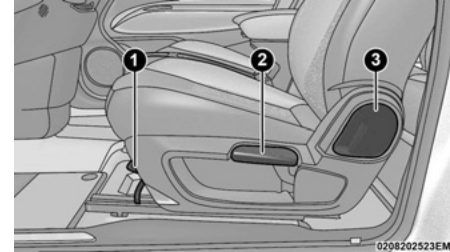

### Manual Seat Adjustment Levers

- 1 – Forward/Rearward Adjustment Bar
- 2 – Seat Height Adjustment Lever (If Equipped)
- 3 – Recline Lever

While sitting in the seat, lift up on the bar located under the seat cushion and move the seat forward or rearward. Release the bar once you have reached the desired position. Then, using body pressure, move forward and rearward on the seat to be sure that the seat adjusters have latched.

**WARNING!**

- Adjusting a seat while driving may be dangerous. Moving a seat while driving could result in loss of control which could cause a collision and serious injury or death.
- Seats should be adjusted before fastening the seat belts and while the vehicle is parked. Serious injury or death could result from a poorly adjusted seat belt.

**Height Adjustment**

The front driver seat height can be raised or lowered by using a lever, located on the outboard side of the seat. Pull upward on the lever to raise the seat height or push downward on the lever to lower the seat height.

**Recline Adjustment**

To adjust the seatback, lift the lever located on the outboard side of the seat, lean back to the desired position and release the lever. To return the seatback, lift the lever, lean forward and release the lever.

**WARNING!**

Do not ride with the seatback reclined so that the shoulder belt is no longer resting against your chest. In a collision you could slide under the seat belt, which could result in serious injury or death.

**MANUAL ADJUSTMENT (REAR SEATS)****WARNING!**

Do not place luggage or cargo higher than the top of the seatback. This could impair visibility or become a dangerous projectile in a sudden stop or collision.

**Manual Folding Rear Seat**

The rear seatbacks have a fold down feature to allow increased cargo capacity.

Push down the release button, located at the outboard top of the seatback and move the seatback to its folded-down position to provide a flat load floor cargo area.

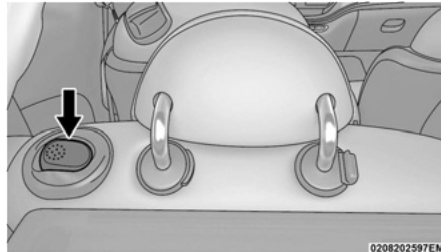
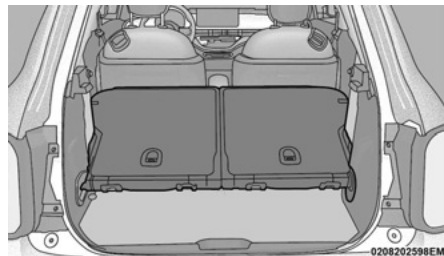
**Rear Seat Release Buttons****Folded Rear Seats****Repositioning The Seatback Upright**

When returning the seatback to its upright position, push rearward until the seatback is properly latched. An audible lock click will be heard. Position the seat belt buckles upwards and set the cushion to the normal use position. Be sure to check that the seat belts do not get stuck between the seatback and interior moulding.

**HEATED SEATS — IF EQUIPPED**

Heated seats can only be activated by soft touch controls on the Uconnect™ system with the ignition device in the ON/RUN position.

**WARNING!**

- Persons who are unable to feel pain to the skin because of advanced age, chronic illness, diabetes, spinal cord injury, medication, alcohol use, exhaustion or other physical condition must

*(Continued)*

**WARNING!**

exercise care when using the seat heater. It may cause burns even at low temperatures, especially if used for long periods of time.

- Do not place anything on the seat or seatback that insulates against heat, such as a blanket or cushion. This may cause the seat heater to overheat. Sitting in a seat that has been overheated could cause serious burns due to the increased surface temperature of the seat.

**HEAD RESTRAINTS**

Head restraints are designed to reduce the risk of injury by restricting head movement in the event of a rear impact. Head restraints should be adjusted so that the top of the head restraint is located above the top of your ear.

**WARNING!**

- All occupants, including the driver, should not operate a vehicle or sit in a vehicle's seat until the head restraints are placed in their proper positions in order to minimize the risk of neck injury in the event of a crash.
- Head restraints should never be adjusted while the vehicle is in motion. Driving a vehicle with the head restraints improperly adjusted or removed could cause serious injury or death in the event of a collision.

**Front Adjustment**

Your vehicle is equipped with driver and passenger head restraints.

To raise the head restraint, pull upward on the head restraint. To lower the head restraint, push the adjustment button, located on the base of the head restraint, and push downward on the head restraint.

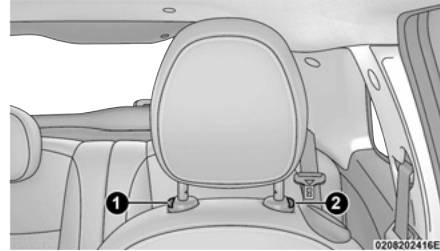
**Front Head Restraint**

- 1 – Adjustment Button  
2 – Release Button

**WARNING!**

- A loose head restraint thrown forward in a collision or hard stop could cause serious injury or death to occupants of the vehicle. Always securely stow removed head restraints in a location outside the occupant compartment.

*(Continued)*

**WARNING!**

- ALL the head restraints **MUST** be reinstalled in the vehicle to properly protect the occupants. Follow the re-installation instructions above prior to operating the vehicle or occupying a seat.
- Do not place items over the top of the Reactive Head Restraint, such as coats, seat covers or portable DVD players. These items may interfere with the operation of the Reactive Head Restraint in the event of a collision and could result in serious injury or death.

**Rear Adjustment**

Your vehicle is equipped with two head restraints for its rear passengers. The rear head restraints can be raised or lowered.

To raise the head restraint, pull upward on the head restraint. To lower the head restraint, push the adjustment button, located at the base of the head restraint, and push downward on the head restraint.

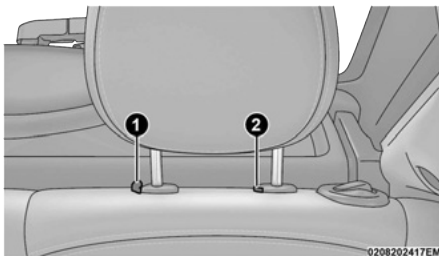

Rear Head Restraint

- 1 — Adjustment Button  
2 — Release Button

**WARNING!**

ALL the head restraints **MUST** be reinstalled in the vehicle to properly protect the occupants. Follow the re-installation instructions above prior to operating the vehicle or occupying a seat.

## Head Restraint Removal

To remove a head restraint, raise it as far as it can go. Then, push the adjustment button and the release button at the base of each post while pulling the head restraint up. To reinstall the head restraint, push the adjustment button and the release button at the base of each post and put the head restraint posts into the holes. Then, adjust it to the appropriate height.

**NOTE:**

Do not reposition the head restraint 180 degrees to the incorrect position in an attempt to gain additional clearance to the back of the head.

## UCONNECT VOICE RECOGNITION QUICK TIPS — IF EQUIPPED

### INTRODUCING VOICE RECOGNITION

Start using Uconnect Voice Recognition with these helpful quick tips. It provides the key Voice Commands and tips you need to know to control your vehicle's Voice Recognition (VR) system.

### BASIC VOICE COMMANDS

The following Basic Voice Commands can be given at any point while using your Uconnect system.

Push the VR button on the steering wheel. After the beep, say a command. You can also say the system "Wake Up" word and then say a command:

- **"Cancel"** to stop a current voice session.
- **"Help"** to hear a list of suggested Voice Commands.
- **"Repeat"** to listen to the system prompts again.

Notice the visual cues that inform you of your Voice Recognition system's status.

### GET STARTED

The  VR button is used to activate/deactivate your Voice Recognition system.

Helpful hints for using Voice Recognition:

- Reduce background noise. Wind noise and passenger conversations are examples of noise that may impact recognition.
- Speak clearly at a normal pace and volume while facing straight ahead.
- Each time you give a Voice Command, first push the VR button, wait until after the beep, then say your Voice Command.
- You can interrupt the help message or system prompts by pushing the VR button and saying a Voice Command from the current category.

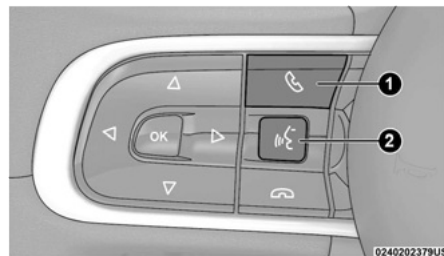

Uconnect Voice Command Buttons

- 1 — Push To Start Or Answer A Phone Call And Send Or Receive A Text  
2 — Push The Voice Recognition Button To Begin Radio, Media, Navigation, and Climate Functions

## ADDITIONAL INFORMATION

© 2024 FCA US LLC. All rights reserved. Mopar and Uconnect are registered trademarks, and Mopar Owner Connect is a trademark of FCA US LLC. SiriusXM® and all related marks and logos are trademarks of SiriusXM® Radio Inc.

Uconnect System Support, call 1-877-855-8400 (24 hours a day 7 days a week) or visit [www.DriveUconnect.com](http://www.DriveUconnect.com) (US) or [www.DriveUconnect.ca](http://www.DriveUconnect.ca) (Canada) ⇨ page 211.

## MIRRORS

### INSIDE REARVIEW MIRROR

#### Manual Mirror – If Equipped

The rearview mirror can be adjusted up, down, left, and right. The mirror should be adjusted to center on the view through the rear window.

Headlight glare from vehicles behind you can be reduced by moving the small control under the mirror to the night position (toward the rear of the vehicle). The mirror should be adjusted while set in the day position (toward the windshield).

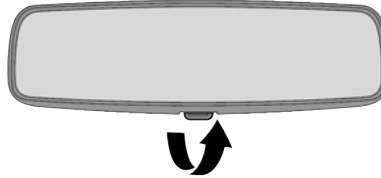

0224202592US

#### Adjusting Rearview Mirror

#### Automatic Dimming Mirror – If Equipped

The rearview mirror can be adjusted up, down, left, and right. The mirror should be adjusted to center on the view through the rear window.

This mirror automatically adjusts for headlight glare from vehicles behind you.



A0215000126US

#### Automatic Dimming Mirror

#### NOTE:

The automatic Dimming Mirror feature is disabled when the vehicle is in REVERSE to improve the driver's rear view.

#### CAUTION!

To avoid damage to the mirror during cleaning, never spray any cleaning solution directly onto the mirror. Apply the solution onto a clean cloth and wipe the mirror clean.

2

### VANITY MIRROR

A vanity mirror is located on the passenger sun visor. To use the mirror, rotate the sun visor down and swing the mirror cover upward.



0224202596US

#### Vanity Mirror

### OUTSIDE MIRRORS

The outside mirror(s) can be adjusted to the center of the adjacent lane of traffic to achieve the optimal view.

#### NOTE:

The passenger side convex outside mirror will give a much wider view to the rear, and especially of the lane next to your vehicle.

**WARNING!**

Vehicles and other objects seen in the passenger side convex mirror will look smaller and farther away than they really are. Relying too much on your passenger side convex mirror could cause you to collide with another vehicle or other object. Use your inside mirror when judging the size or distance of a vehicle seen in the passenger side convex mirror.

**POWER MIRRORS**

The power mirror switch is located on the driver's door trim panel.

To adjust the mirror, rotate the mirror selection switch to the left or to the right and then push the mirror adjustment switch in the four directions indicated by arrows.

**NOTE:**

- To adjust the power mirrors, the ignition must be in the ON/RUN position.
- Once the mirror is adjusted, rotate the control to the neutral position to avoid accidental movements.
- The power mirror switches will remain active for up to three minutes after the ignition is placed in the OFF position. Opening either front door will cancel this feature.

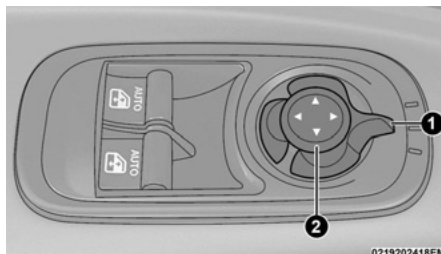
**Power Mirror Switch**

- 1 – Mirror Selector Switch  
2 – Mirror Adjustment Switch

**FOLDING MIRRORS**

The exterior mirrors are hinged to allow the mirror to pivot forward or rearward to help avoid damage. The mirror can be fold manually from the open position to the closed position.

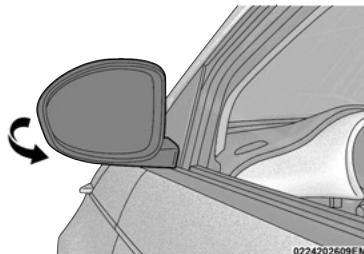
**Folding Exterior Mirror****HEATED MIRRORS — If Equipped**

These mirrors are heated to melt frost or ice. This feature will be activated whenever you turn on the rear window defroster (if equipped) ⇨ page 43.

**EXTERIOR LIGHTS****MULTIFUNCTION LEVER**

The multifunction lever, located on the left side of the steering wheel, controls the operation of the headlights, parking lights, turn signals, headlight beam selection, and the passing lights.

**NOTE:**

The headlights can only be turned on with the ignition in the ON/RUN position.

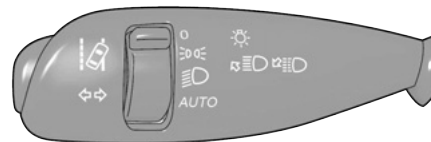

0235202763EM

**Multifunction lever**



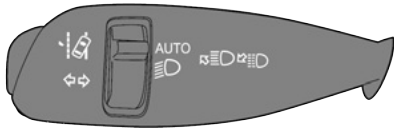

0235202424EM

### Multifunction lever (Vehicles Sold In Canada Only)

## HEADLIGHTS

To turn on the headlights, rotate the end of the multifunction lever to the headlight position. When the headlight switch is on, the parking lights, taillights, license plate light, and instrument panel lights are also turned on. To turn off the headlights, rotate the end of the multifunction lever back to the O (off) position.

### NOTE:

On vehicles sold in Canada, the rear parking lights, and Daytime Running Lights (DRLs) will turn on when the headlight switch is rotated to the O (off) position.

## AUTOMATIC HEADLIGHTS

This system automatically turns the headlights on or off according to ambient light levels. To turn the system on, with the engine running, rotate the headlight switch to the AUTO position.

To turn the automatic headlights off, turn the headlight switch out of the AUTO position.

## DAYTIME RUNNING LIGHTS

The Daytime Running Lights (DRLs) are activated with the switch in the AUTO position and in daylight conditions.

### NOTE:

With the ignition system in the ON/RUN position and the propulsion system not active, the daytime running lights are switched off.

### NOTE:

On some vehicles, the Daytime Running Lights may deactivate or reduce intensity on one side of the vehicle (when a turn signal is activated on that side), or on both sides of the vehicle (when the hazard warning lights are activated).

## AUTOMATIC LIGHTING CONTROL (AUTOLIGHT)

### — DUSK SENSOR

The light sensor is equipped with an infrared LED, located on the windshield. It detects changes in light intensity outside the vehicle, based on the sensitivity of light set by using the menu on the display or on the Uconnect system.

The higher the sensitivity, the lesser the amount of external light required for controlling the lighting.

With the ignition system in the ON/RUN position, rotate the switch to the AUTO position to activate the "Automatic lighting control" function.

## HIGH BEAMS

To activate the high beam headlights, with the ignition system in the ON/RUN position, push the multifunction

lever forward (toward the front of the vehicle), and an indicator will illuminate in the instrument cluster display. The headlights must be in the ON position.

To deactivate the high beam headlights, pull the multifunction lever rearward (toward the rear of the vehicle).

## AUTOMATIC HIGH BEAM HEADLAMP CONTROL — IF EQUIPPED

In order not to dazzle other road users, the lights are automatically deactivated when approaching cars travelling in the opposite direction or when following a car travelling in the same direction.

### NOTE:

- The Automatic High Beam Headlamp Control can be turned on or off by selecting "ON" under "Auto Dim High Beams" within your Uconnect Settings ➡ page 113, as well as turning the headlight switch to the AUTO position.
- Broken, muddy, or obstructed headlights and taillights of vehicles in the field of view will cause headlights to remain on longer (closer to the vehicle). Also, dirt, film, and other obstructions on the windshield or camera lens will cause the system to function improperly.
- If the windshield or Automatic High Beam Headlamp Control mirror is replaced, the mirror must be re-aimed to ensure proper performance. See a local authorized dealer.

## FLASH-TO-PASS

You can signal another vehicle with your headlights by lightly pulling the multifunction lever toward you. This will cause the high beam headlights to turn on, and remain on, until the lever is released.

## PARKING LIGHTS

With the ignition system turned to the OFF position, rotating the switch from the AUTO position to the Parking Lights will light up the side/tail lights and number plate lights.

The parking light indicator in the cluster will illuminate.

## FOLLOW ME HOME/HEADLIGHT DELAY

When this feature is selected, the driver can choose to have the headlights remain on for a preset period of time.

### Headlight Delay Activation

To activate the delay feature, place the ignition in the OFF position while the headlights are still on. Then, turn off the headlights within two minutes. The delay interval begins when the headlight switch is turned off.

### Headlight Delay Deactivation

The feature is disabled by turning on the headlights, the parking lights or by placing the ignition in the ON/RUN position.

If you shut off the lights before the ignition is turned on, they will turn off in the normal manner.

### NOTE:

The lights must be turned off within two minutes of placing the ignition in the OFF position to activate this feature.

## REAR FOG LIGHTS

The fog light switch is located on the instrument panel to the left just below the steering wheel.

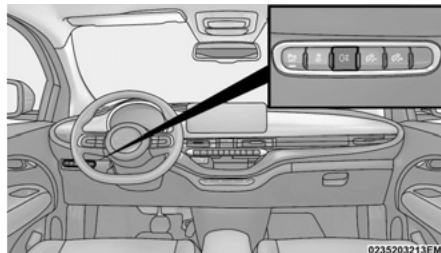

Rear Fog Light Switch

To activate the rear fog lights, push the button switch. To turn off the rear fog lights, push the button switch a second time.

### NOTE:

To turn on the rear fog lights, the low beam headlights must first be active.

An indicator light in the instrument cluster illuminates when the fog lights are turned on.

## TURN SIGNALS

Push the multifunction lever upward to signal a right turn or downward to signal a left turn. The corresponding indicator in the instrument cluster display will blink to indicate the operation of the turn signal.

### NOTE:

The indicators will automatically turn off when the turn has been completed and the steering wheel is returned to a straight position.

## LANE CHANGE ASSIST

If you wish to signal a lane change, place the multifunction lever in the unstable position for less than half a second.

The turn signal will flash five times then automatically turn off.

## INTERIOR LIGHTS

### FRONT COURTESY LIGHT

The courtesy lights will automatically turn on when the door is open or closed.

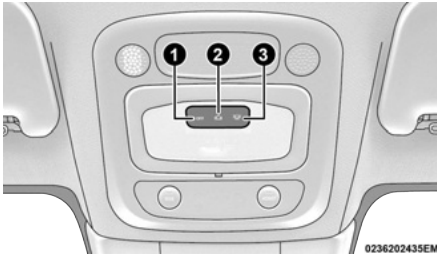

### Front Courtesy Lights

- 1 — Lights Always Off
- 2 — Lights On/Off Opening or Closing the Doors
- 3 — Lights Permanently On

#### NOTE:

- Before exiting the vehicle, make sure that the interior lights are turned off. This will prevent the battery from discharging once the doors are closed.
- If lights are left on it will automatically be turned off after approximately 15 minutes after the ignition is in the OFF position.

### Dome Light Timing

The dome light will automatically illuminate when the doors are unlocked, the doors are opened or after the doors are closed.

#### Timing Entering The Vehicle

The dome lights illuminate in the following ways:

- When the doors are unlocked, the dome light will illuminate for approximately 27 seconds.

- When one of the doors is opened, the dome light will illuminate for approximately three minutes.
- When the doors are closed, the dome light will automatically shut off after approximately 27 seconds.

#### NOTE:

The timing stops once the ignition is placed in the RUN position.

The dome light will turn off under any of the following conditions:

- The dome light is disabled when the ignition is placed in the RUN Position.
- The dome lights will turn off automatically when the doors are locked.
- The dome lights will automatically turn off after approximately 15 minutes of inactivity to preserve the battery.

#### Timing Exiting The Vehicle

The dome light will illuminate under the following conditions when the ignition is placed in the OFF position:

- The dome light will illuminate for 27 seconds after the key fob is removed from the vehicle.
- The opening of one of the doors (approximately three minutes).
- After closing a door (approximately 27 seconds).

The dome light timing is disabled when the doors are locked.

### Instrument Panel Dimmer Control

To adjust the instrument panel dimmer control, press the buttons located on the left side of the dashboard.

Pressing the instrument panel dimmer buttons will adjust the brightness of the instrument panel lights **ONLY** when the parking lights or headlights are turned on, **AND ONLY** if the built in light sensor determines that the ambient light levels are low enough that the backlighting should be enabled.

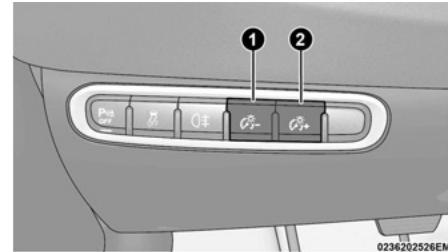

### Instrument Panel Dimmer Buttons

- 1 — Decrease Brightness
- 2 — Increase Brightness

### CARGO AREA LIGHTS

An interior light is located on the left side panel in the cargo area.

This light automatically turns on/off when the liftgate is opened and closed, regardless of the position of the ignition.

**NOTE:**

In order to preserve the life of the battery, the light will turn off after 15 minutes.

## WIPERS AND WASHERS

The windshield wiper/washer controls are located on the lever on the right side of the steering column. There are five different modes of operation for the front windshield wipers.

**NOTE:**

The windshield wipers/washers will only operate while the vehicle's ignition system is in the ON/RUN position.

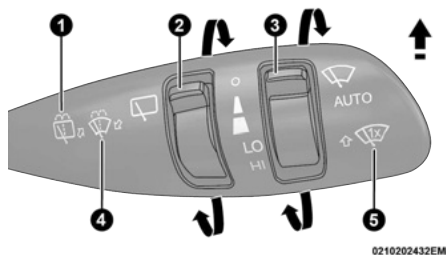

Windshield Wiper/Washer Lever

- 1 — Push Forward For Rear Washer
- 2 — Rotate For Rear Wiper Operation
- 3 — Rotate For Front Wiper Operation
- 4 — Pull For Front Washer
- 5 — Push Up For Mist

## FRONT WINDSHIELD WIPER OPERATION

Rotate the windshield wiper knob to one of the first two detent positions for intermittent settings, the third detent for low wiper operation and the fourth for high wiper operation.

**Smart washing function**

Pull the stalk towards the steering wheel (unstable position) to operate the windshield washer.

Keep the lever pulled to activate both the windshield washer jet and the windshield wiper with a single movement; the latter turns on automatically if you keep the lever pulled for more than half a second.

### WARNING!

Sudden loss of visibility through the windshield could lead to a collision. You might not see other vehicles or other obstacles. To avoid sudden icing of the windshield during freezing weather, warm the windshield with the defroster before and during windshield washer use.

**Mist**

Use the Mist feature when weather conditions make occasional usage of the wipers necessary. Push the lever upward to the MIST position and release for a single wiping cycle.

**NOTE:**

The mist feature does not activate the washer pump; therefore, no washer fluid will be sprayed on the windshield. The washer function must be used in order to spray the windshield with washer fluid.

## REAR WINDSHIELD WIPER

The rear wiper/washer controls are located on the windshield wiper lever on the right side of the steering column. The rear wiper/washer is operated by rotating a switch, located on the left side of the lever.

**NOTE:**

If the front wipers are moving and the vehicle is shifted in REVERSE, the rear wiper will perform one round up to clean the rear window.



Rotate the center portion of the lever upward to the first detent for intermittent operation and to the second detent for continuous rear wiper operation.



To use the washer, push the lever forward and hold while spray is desired. If the lever is pushed while in the intermittent setting, the wiper will turn on and operate for several wipe cycles after the end of the lever is released, and then resume the intermittent interval previously selected.

**NOTE:**

As a protective measure, the pump will stop if the switch is held for more than 30 seconds. Once the lever is released, the pump will resume normal operation.

If the lever is pushed while the wiper is in the off position, the wiper will operate for several wipe cycles, then turn off.

If the rear wiper is operating when the ignition is placed in the OFF position, the wiper will automatically return to the parked position.

**CAUTION!**

Failure to follow these cautions can cause damage to the heating elements:

- Use care when washing the inside of the rear window. Do not use abrasive window cleaners on the interior surface of the window. Use a soft cloth and a mild washing solution, wiping parallel to the heating elements. Labels can be peeled off after soaking with warm water.
- Do not use scrapers, sharp instruments, or abrasive window cleaners on the interior surface of the window.
- Keep all objects a safe distance from the window.

**RAIN SENSING WIPERS — IF EQUIPPED**

This feature senses rain or snowfall on the windshield and automatically activates the wipers. Rotate the end of the windshield wiper lever to one of the two detent positions to activate this feature.

**NOTE:**

- The Rain Sensing feature will not operate when the wiper switch is in the LO, HI, or OFF position. Only in one of the intermittent positions.
- The Rain Sensing feature may not function properly when ice or dried saltwater is present on the windshield.
- Use of products containing wax or silicone may reduce rain sensor performance.

- The Rain Sensing feature can be turned on and off through the Uconnect system → page 113.

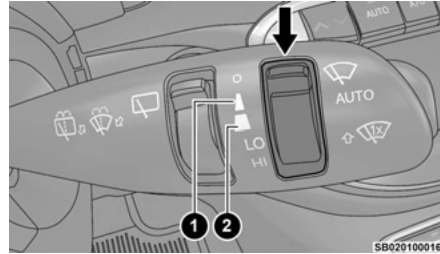
**Rain sensing stalk**

- 1 — Automatic Wiping - Slow  
2 — Automatic Wiping - Fast

Rotate the switch the first detent for slow operation or the second detent for fast operation.

Place the ring in the O (off) position when not using the system.

**NOTE:**

In the event of a rain sensor failure, a dedicated telltale on the instrument cluster will appear to warn the customer (if equipped).

**CLIMATE CONTROLS**

The Climate Control System allows you to regulate the temperature, air flow, and direction of air circulating throughout the vehicle. The controls are located on the touchscreen and on the instrument panel below the radio.

**NOTE:**

In the event of low high voltage battery levels or very cold/very hot weather, remember to connect the vehicle to a power outlet to enable climate programming.

**TEMPERATURE CONTROL OVERVIEW****Uconnect 5 NAV With 10.25–  
inch Display Automatic Climate Controls****MAX A/C Button**

Press and release the MAX A/C button on the touchscreen to change the current setting to the coldest output of air. The MAX A/C indicator illuminates when MAX A/C is on. Pressing the button again will cause the MAX A/C operation to exit. Pressing other settings will cause the MAX A/C to exit.

**NOTE:**

The MAX A/C button is only available on the touchscreen.

**A/C Button**

Press and release the A/C button on the touchscreen, or push the button on the faceplate to change the current setting. The A/C indicator illuminates when A/C is ON.

The Air Conditioning (A/C) button allows the operator to manually activate or deactivate the air conditioning system. When the air conditioning system is turned on, dehumidified air will flow through the outlets into the cabin.

If your air conditioning performance seems lower than expected, check the front of the A/C condenser (located in front of the radiator), for an accumulation of dirt or insects. Clean with a gentle water spray from the front of the radiator and through the condenser. If the problem persists, please contact an authorized dealer.

**Recirculation Button**

Press and release this button on the touchscreen, or push the button on the faceplate, to change the system between recirculation mode and outside air mode.

The Recirculation indicator and the A/C indicator illuminate when the Recirculation button is pressed. Recirculation can be used when outside conditions such as smoke, odors, dust, or high humidity are present. Recirculation can be used in all modes. Recirculation may be unavailable (button on the touchscreen grayed out) if conditions exist that could create fogging on the inside of the windshield. The

A/C can be deselected manually without disturbing the mode control selection. Continuous use of the Recirculation mode may make the inside air stuffy and window fogging may occur. Extended use of this mode is not recommended.

**NOTE:**

- After a long period of continuous use, Recirculation mode will automatically shut off for two minutes to allow fresh air intake inside the cabin to maintain sufficient oxygen levels.
- Recirculation mode will function in this way, in either automatic or manual override mode.

**AUTO Button**

Press and release this button on the touchscreen, or push the button on the faceplate, to change the current setting. The AUTO indicator illuminates when AUTO is on.

This feature automatically controls the interior cabin temperature by adjusting distribution and amount of airflow. Toggling this function will cause the system to switch between manual override mode and automatic modes → page 45.

**MAX Defrost Button**

Press and release the touchscreen button, or push and release the button on the faceplate, to change the current airflow setting to Defrost mode. The MAX Defrost indicator illuminates when MAX Defrost is on. Air comes from the windshield and side window demist outlets. When the MAX defrost button is selected, the blower level may increase and the maximum temperature setting is selected. When toggling the MAX defrost

mode button, the Climate Control system will return to the previous setting.

**Rear Defrost Button**

Press and release the button on the touchscreen, or push and release the button on the faceplate, to turn on the rear window defroster and the heated outside mirrors (if equipped). The Rear Defrost indicator illuminates when the rear window defroster is on. The rear window defroster automatically turns off after 10 minutes.

**CAUTION!**

Failure to follow these cautions can cause damage to the heating elements:

- Use care when washing the inside of the rear window. Do not use abrasive window cleaners on the interior surface of the window. Use a soft cloth and a mild washing solution, wiping parallel to the heating elements. Labels can be peeled off after soaking with warm water.
- Do not use scrapers, sharp instruments, or abrasive window cleaners on the interior surface of the window.
- Keep all objects a safe distance from the window.

## Temperature Control Buttons

These buttons provide temperature control.



Push upward on the driver's side toggle switch on the faceplate, or press and slide the temperature bar towards the red arrow button on the touchscreen for warmer temperature settings. Push downward the driver's side toggle switch on the faceplate, or press and slide the temperature bar towards the blue arrow button on the touchscreen for cooler temperature settings.

## Blower Control



Blower Control is used to regulate the amount of air forced through the Climate Control system. There are seven blower speeds available. Adjusting the blower will cause automatic mode to switch to manual operation. The speeds can be selected using either the blower control button on the faceplate or the buttons on the touchscreen.

### Faceplate

The blower speed increases as you push upward the blower control button from the lowest blower setting. The blower speed decreases as you push downward the blower control button.

### Touchscreen

Use the small blower icon to reduce the blower setting and the large blower icon to increase the blower setting. Blower can also be selected by pressing the blower bar area between the icons.

## Panel Mode



Air comes from the outlets in the instrument panel. Each of these outlets can be individually adjusted to direct the flow of air. The air vanes of the center outlets and outboard outlets can be moved up and down or side to side to regulate airflow direction. There is a shut-off wheel located below the air vanes to shut off or adjust the amount of airflow from these outlets.

## Bi-Level Mode



Air comes from the instrument panel outlets and floor outlets. A slight amount of air is directed through the defrost and side window demister outlets.

### NOTE:

Bi-Level mode is designed under comfort conditions to provide cooler air out of the panel outlets and warmer air from the floor outlets.

## Floor Mode



Air comes from the floor outlets. A slight amount of air is directed through the defrost, side window demister outlets.

## Defrost Mode



Air comes from the windshield and side window demister outlets. Use Defrost mode with maximum temperature settings for best windshield and side window defrosting and defogging.

## Mix Mode



Air is directed through the floor, defrost, and side window demister outlets. This setting works best in cold or snowy conditions that require extra heat to the windshield. This setting is ideal for maintaining comfort while reducing moisture on the windshield.

## Climate Control OFF Button



Press and release the OFF button on the touchscreen, or push and release the OFF button on the faceplate to turn the Climate Control ON/OFF.

## AUTOMATIC TEMPERATURE CONTROL (ATC)

### Automatic Operation

1. Push the AUTO button on the faceplate, or the AUTO button on the touchscreen on the Automatic Temperature Control (ATC) Panel.
2. Next, adjust the temperature you would like the system to maintain by adjusting the temperature control buttons. Once the desired temperature is displayed, the system achieves and automatically maintains that comfort level.
3. When the system is set up for your comfort level, it is not necessary to change the settings. You experience the greatest efficiency by simply allowing the system to function automatically.

**NOTE:**

- It is not necessary to move the temperature settings for cold or hot vehicles. The system automatically adjusts the temperature, mode, and blower speed to provide comfort as quickly as possible.
- The temperature can be displayed in U.S. or Metric units by selecting the US/Metric customer-programmable feature.

To provide you with maximum comfort in the Automatic mode during cold start-ups, the blower fan remains on low until the vehicle warms up. The blower increases in speed and transition into Auto mode.

## Manual Operation Override

This system offers a full complement of manual override features. The AUTO symbol in the front ATC display will be turned off when the system is being used in the manual mode.

**NOTE:**

When in manual override mode, the system will not automatically sense the presence of fog, mist or ice on the windshield. Defrost mode must be manually selected to clear the windshield and side glass.

## CLIMATE VOICE COMMANDS

Adjust vehicle temperatures hands-free and keep everyone comfortable while you keep moving ahead.

Push the VR button on the steering wheel. After the beep, say one of the following commands:

- **“Set the temperature to 70 degrees”**

**Did You Know:** Voice Command for Climate may only be used to adjust the interior temperature of your vehicle. Voice Command will not work to adjust the heated seats if equipped.

## SCHEDULED CABIN CONDITIONING (SCC)

This feature allows the driver to pre-condition (warm up or cool down) the passenger cabin based on a planned departure time. Also, all scheduled cabin conditioning will be powered by the vehicle's high voltage battery working in conjunction with any EVSE connected to the vehicle.

In order to conserve the vehicle's high voltage battery power, the driver can choose between allowing the battery to be drained of power down to <1%, or to stop the SCC when the high voltage battery has been depleted to 25% State Of Charge (SOC). The battery percentages are displayed in the instrument cluster display.

A maximum of three independent schedule event timers are available for use by the SCC feature and Scheduled Charging feature for charging the high voltage battery. The timers may be used in any combination for SCC and Scheduled Charging, but only three total timers are available.

The SCC event times are used to wake up the vehicle so that the Climate Control system can condition the passenger cabin prior to the scheduled departure time. Based on vehicle operating conditions, ambient

temperature, and the next programmed departure time, the vehicle will determine when to begin cabin conditioning. Cabin conditioning can begin up to 30 minutes prior to the scheduled departure time, provided the stated high voltage battery conditions are met.

The SCC will continue for a maximum of 15 minutes after the scheduled departure time.

Once a scheduled event has been created, it can be applied to one or more days of the week. The scheduled event can also be set to occur only during the current week, or repeat every week until the feature is turned off or the event is changed.

All of the following conditions must be met before the vehicle will initiate a scheduled SCC event:

- Gear selector in PARK
- Doors Closed
- Hood Closed
- Liftgate Closed
- Hazard switch off
- 12 Volt battery at an acceptable charge level
- Key fob not located inside the vehicle
- Ignition in the OFF position

### Scheduling An SCC Event:

1. Select the Electric Vehicle App under the Vehicle menu.



2. Select “Schedules”.

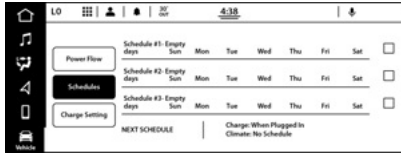

### Schedules Screen

3. Select the schedule to be set (1,2, or 3) by pressing the appropriate arrow on the right side of the touchscreen.
4. Choose “Climate Schedule”.

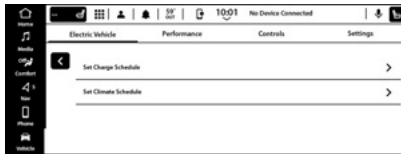

### Select Climate Schedule

5. Select if SCC should stop when the high voltage battery drops to 25% or lower.
6. Set the Departure Time: Hours, Minutes, and AM/PM.

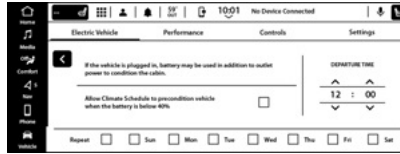

### Set Climate Schedule

7. Select the days that this SCC event will occur. The “Repeat” indicator illuminates to indicate that SCC will occur every week on the selected day(s), at the selected time.

If you uncheck the “Repeat” option, all the days of the week will be grayed out and the vehicle will perform only one SCC event, which will occur at the next available time that matches the SCC event time (regardless of what day it was originally set to occur before “Repeat” was unchecked).

8. To schedule another SCC event, press the X and repeat these steps.

## OPERATING TIPS

Refer to the chart at the end of this section for suggested control settings for various weather conditions.

### Summer Operation

The vehicle cooling system must be protected with a high-quality antifreeze coolant to provide proper corrosion protection and to protect against vehicle overheating. OAT coolant (conforming to MS.90032) is recommended.

### Winter Operation

To ensure the best possible heater and defroster performance, make sure the vehicle cooling system is functioning properly and the proper amount, type, and concentration of coolant is used. Use of the Air Recirculation mode during Winter months is not recommended, because it may cause window fogging.

### Vacation/Storage

For information on maintaining the Climate Control system when the vehicle is being stored for an extended period of time, see page 202.

### Window Fogging

Vehicle windows tend to fog on the inside in mild, rainy, and/or humid weather. To clear the windows, select Defrost or Mix mode and increase the front blower speed. Do not use the Recirculation mode without A/C for long periods, as fogging may occur.

### Outside Air Intake

Make sure the air intake, located directly in front of the windshield, is free of obstructions, such as leaves. Leaves collected in the air intake may reduce airflow, and if they enter the air distribution box, they could plug the water drains. In Winter months, make sure the air intake is clear of ice, slush, and snow.

### Cabin Air Filter

The Climate Control system filters out dust and pollen from the air. Contact an authorized dealer to service your cabin air filter, and to have it replaced when needed.

## Windshield Wiper De-Icer — If Equipped

The windshield wiper De-Icer is a heating element located at the base of the windshield.

It operates automatically once the following conditions are met:



- **Activation By Front Defrost**



The wiper De-Icer activates automatically during a cold weather manual start with **full defrost**, and when the **ambient temperature is below 33°F (6°C)**.

- **Activation By Rear Defrost**

The wiper De-Icer activates automatically when the Rear Defrost is operating and the **ambient temperature is below 33°F (6°C)**.

## Operating Tips Chart

WEATHER	CONTROL SETTINGS
Hot Weather And Vehicle Interior Is Very Hot	Set the mode control to  (Panel Mode), <sup>MAX</sup> A/C (MAX A/C) on, and blower on high. Roll down the windows for a minute to flush out the hot air. Adjust the controls as needed to achieve comfort.
Warm Weather	Turn A/C (A/C) on and set the mode control to  (Panel Mode).
Cool Sunny	Operate in  (Bi-Level Mode).

WEATHER	CONTROL SETTINGS
Cool & Humid Conditions	Set the mode control to  (Mix Mode) and turn A/C (A/C) on to keep windows clear.
Cold Weather	Set the mode control to  (Floor Mode). If windshield fogging starts to occur, move the control to  (Mix Mode).

## INTERIOR STORAGE AND EQUIPMENT

### STORAGE

#### Glove Compartment

The glove compartment is located on the passenger side of the instrument panel.

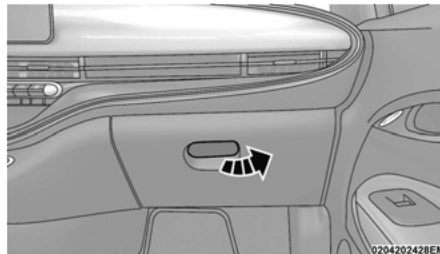

Glove Compartment

To open the glove compartment, pull the release handle.

WARNING!
Do not operate this vehicle with a glove compartment in the open position. Driving with the glove compartment open may result in injury in a collision.

#### Center Console Storage Compartment

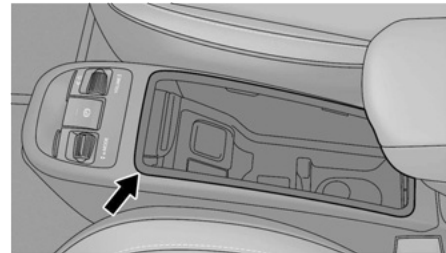

#### Center Console Storage Compartment

The center console has a storage area which can hold small items.

#### Front Armrest — If Equipped

To access the front armrest compartment, pull the lever upwards and lift the armrest.

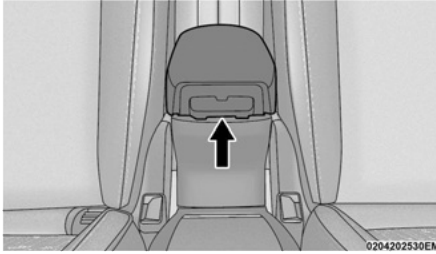

### Front Armrest

The armrest has a storage area which can hold cell phones, PDAs, and other small items. The armrest can slide forward and rearward for comfort.

#### WARNING!

Do not operate this vehicle with a console compartment lid in the open position. Driving with the console compartment lid open may result in injury in a collision.

## CUPHOLDERS

### Front Cupholders

For the driver and front passenger, retractable cupholders are located on the front part of the central console.

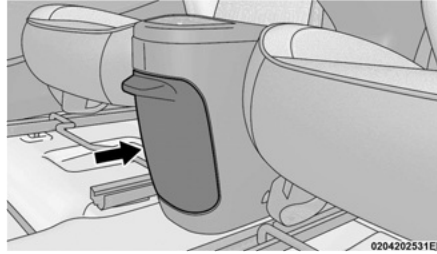

### Front Cupholders

Open the latch using the handle to access the front cupholders.

### Rear Cupholder

For rear passengers, there is a cupholder located on the back of the central console.

## USB/MEDIA PLAYER CONTROL

Located below the air conditioning controls is the front USB port.

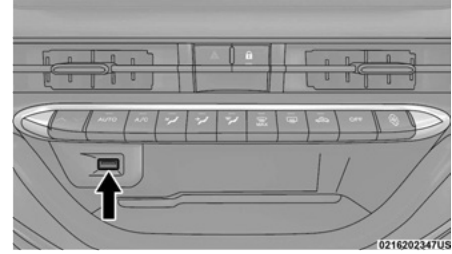

### Front USB Port

This feature allows an external device to be plugged into the USB port.

#### NOTE:

Charge unsupported devices with the Charge Only USB ports. If an unsupported device is plugged into a Media USB port, a message will display on the touchscreen that the device is not supported by the system.

### Center Console USB Port

A second, charge only USB port is located inside the center console storage compartment.

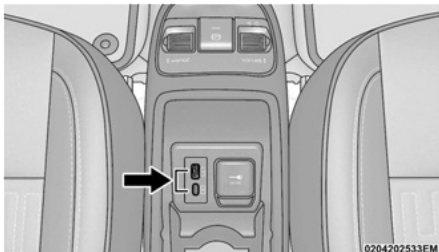

**Center Console USB Port**

**NOTE:**

Depending on vehicle configuration, the USB port may be charge only or media file capable.

## ELECTRICAL POWER OUTLETS

There is a standard 12 Volt (13 Amp) power outlet, located in the center console storage compartment, for added convenience. This power outlet can power mobile phones, electronics and other low power devices.

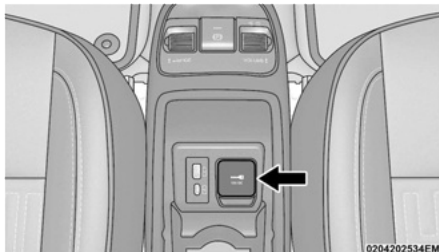

**Power Outlet**

Power is available when the ignition switch is in the ON/RUN position.

**CAUTION!**

- Do not exceed the maximum power of 160 Watts (13 Amps) at 12 Volts. If the 160 Watts (13 Amps) power rating is exceeded, the fuse protecting the system will need to be replaced.
- Power outlets are designed for accessory plugs only. Do not insert any other object in the power outlets as this will damage the outlet and blow the fuse. Improper use of the power outlet can cause damage not covered by your New Vehicle Limited Warranty.

**WARNING!**

To avoid serious injury or death:

- Only devices designed for use in this type of outlet should be inserted into any 12 Volt outlet.
- Do not touch with wet hands.
- Close the lid when not in use and while driving the vehicle.
- If this outlet is mishandled, it may cause an electric shock and failure.

**CAUTION!**

- Many accessories that can be plugged in draw power from the vehicle's battery, even when not in use (i.e., cellular phones, etc.). Eventually, if plugged in long enough, the vehicle's battery will discharge sufficiently to degrade battery life and/or prevent the vehicle from moving.
- Accessories that draw higher power (i.e., coolers, vacuum cleaners, lights, etc.) will degrade the battery even more quickly. Only use these intermittently and with great caution.
- After the use of high power draw accessories, or long periods of the vehicle not being charged (with accessories still plugged in), the vehicle will likely need to be charged.

## WIRELESS CHARGING PAD

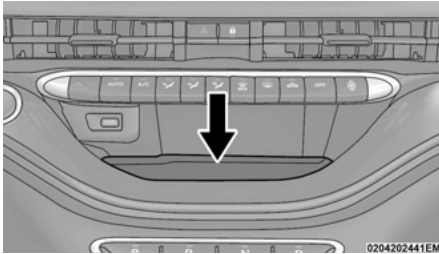

### Wireless Charging Pad

Your vehicle is equipped with a 15W 3A Qi® wireless charging pad located below the center stack, within the storage compartment. This charging pad is designed to wirelessly charge your Qi® enabled mobile phone. Qi® is a standard that allows wireless charging of your mobile phone.

Your mobile phone must be designed for Qi® wireless charging. If the phone is not equipped with Qi® wireless charging functionality, an aftermarket sleeve or a specialized back plate can be purchased from your mobile phone provider or a local electronics retailer. Please see your phone's Owner's Manual for further information.

The wireless charging pad is equipped with an anti-slip mat to hold your mobile phone in place, and an LED indicator light.

Place the device inside the prepared area delimited in the mat as shown in the image. Incorrect positioning will prevent the phone from charging.

### LED Indicator Status:

- No Light: Charging pad is idle or searching for a device. Device may not be compatible with the Qi® standard.
- Blue Light: Device is detected and is charging.
- Red Light/Flashing: Internal error, or foreign object is detected.
- Green Light: Device has completed battery charging (if device is equipped to transmit this information).

### Important Notes Regarding This Vehicle's Wireless Charging Pad:

- The presence of the Near-Field Communication (NFC) function active on a smartphone could signal malfunction anomalies.
- The ignition must be in the ON/RUN position in order for the phone to charge.
- To avoid interference with the key fob search, the wireless charging pad will stop charging when any door or liftgate is opened, even if the engine is running.
- Be sure to place the mobile device correctly (display facing upward, and phone not covering the LED) on the wireless charging pad.
- If the phone moves on the pad causing the red light to illuminate, the phone will have to be picked up and placed back on the charging pad to resume charging.
- Wireless charging is not as fast as when the phone is connected to a wired charger.
- The phone's protective case must be removed when placed on the wireless charging pad.
- Most smartphones are equipped with software to protect the device from overheating. When the software is active, the rate of charge is slowed down to protect the device.
- Phones must always be placed on the wireless charging pad within the outline shown on the pad so that its charging parts connect with the charging coils of the system. Movement of the phone during charging may prevent or slow the rate of charge.
- Having multiple applications open on the phone while charging will reduce the charging efficiency, and may even shut down an application that is actively running (i.e. Apple CarPlay®). This may also cause the phone to overheat.
- Wireless chargers may implement certain methods to prevent the phone from overheating during charging such as slowing down the rate of charge. In certain instances, the device may shut down for a brief period of time (when the device reaches a certain temperature). If this happens, it does not mean there is a fault with the wireless charging pad. This may just be a protective measure to prevent damage to the phone.
- The use of multiple wireless functions at the same time (wireless charging, Apple CarPlay®, Android Auto™) could cause the device to overheat, resulting in limitation of the functions or it turning off. In this case, it is recommended to connect the system using the USB port.

- Do not place the key fob or any other type of metal/magnetized object inside the mobile phone housing or near the wireless charging pad.
- With a compatible device placed on the charging pad, and the ignition is cycled to the OFF position, a reminder message may appear on the instrument cluster display to warn the driver.

**CAUTION!**

The key fob should not be placed on the charging pad or within 6 inches (15 cm) of it. Doing so during the charging of the smartphone could cause excessive heat buildup and damage to the fob, but the wireless charger has a protection system that interrupts the charging when a foreign object is detected on the pad. Placing the fob in close proximity of the charging pad blocks the fob from being detected by the vehicle and prevents the vehicle from starting.

**SUN VISORS**

The driver and passenger sun visors are located on the headliner, near the front windshield. The sun visors can be rotated downward or up against the door glass. The passenger sun visor is equipped with a vanity mirror.

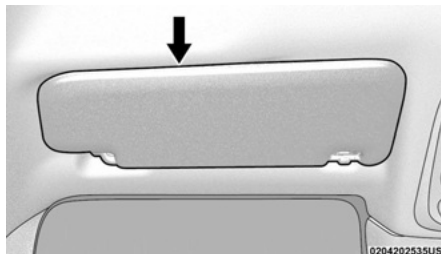
**Sun Visor****WINDOWS****POWER WINDOW CONTROLS**

The window controls will operate only when the ignition is in the ON/RUN position and for up to three minutes after the ignition is placed in the OFF position.

The windows controls buttons are located on the driver's door trim panel, allowing you to control all the door windows. The passenger door windows can also be operated by using the single window controls on the passenger door trim panel.

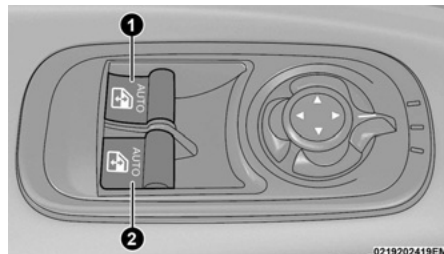
**Power Window Switches**

- Left Window Switch Opening/Closing
- Right Window Switch Opening/Closing

**WARNING!**

Never leave children unattended in a vehicle, and do not let children play with power windows. Do not leave the key fob in or near the vehicle, or in a location accessible to children. Occupants, particularly unattended children, can become entrapped by the windows while operating the power window switches. Such entrapment may result in serious injury or death.

**AUTOMATIC WINDOW FEATURES**

Both the driver and front passenger windows, and if equipped, both rear windows, may have Auto-Down and Auto-Up operations.

### Auto-Down Feature

For windows equipped with the AUTO feature, push the window switch down to the second detent, release, and the window will go down automatically.

To stop the window from going all the way down during the Auto-Down operation, pull up or push down on the switch briefly.

### Auto-Up Feature With Anti-Pinch Protection

For windows equipped with the AUTO feature, lift the window switch up to the second detent, and release; the window will go up automatically.

To stop the window from going all the way up during the Auto-Up operation, push down on the switch briefly.

To close the window part way, lift the window switch briefly and release it when you want the window to stop.

If the window runs into any obstacle during auto-closure, it will reverse direction and then go back down. Remove the obstacle and use the window switch again to close the window.

#### NOTE:

Any impact due to rough road conditions may trigger the auto-reverse function unexpectedly during auto-closure. If this happens, pull the switch lightly and hold to close the window manually.

#### WARNING!

There is no anti-pinch protection when the window is almost closed. To avoid personal injury be sure to clear your arms, hands, fingers and all objects from the window path before closing.

## RESET AUTO-UP

Should the Auto-Up feature stop working, the window may need to be reset.

#### To reset Auto-Up

Pull the window switch up to close the window completely and continue to hold the switch up for an additional two seconds after the window is closed.

## HOOD

### OPENING THE HOOD

#### WARNING!

**For BEV models:** Always place the ignition in the OFF position before opening the hood. If the ignition is in the RUN position and the Propulsion System is active when the hood is opened, the electric motor could automatically start, and persons not clear of the vehicle could be injured by the electric motor's moving parts.

To open the hood, two latches must be released.

1. Pull the hood release lever located underneath the driver's side of the instrument panel.

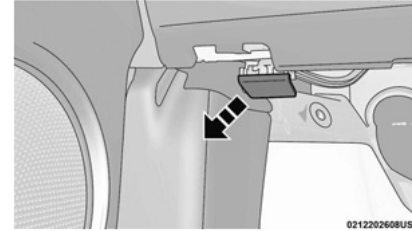

Hood Release

2. Move to the outside of the vehicle, reach into the opening beneath the center of the hood and push the lever toward the passenger side of the vehicle to fully release the hood.

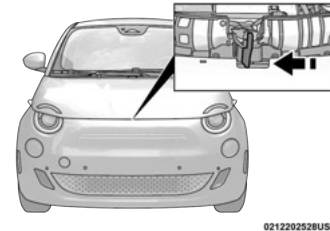

Hood Safety Latch Lever Location

#### NOTE:

- Vehicle must be at a stop and the gear selector must be in PARK.
- You may have to push down slightly on the hood before pushing the safety latch.

- While lifting the hood, use both hands.
- Before lifting the hood, check that the wiper arms are not in motion and not in the lifted position.
- **For BEV Models:** If the vehicle was actively charging the high voltage battery when the hood was opened, the vehicle will stop charging until the hood is closed.
- **For BEV models:** Electric drive mode will not be available while the hood is open. A message will show in the instrument cluster display to alert the driver.

## To Close The Hood

Hoods equipped with gas props are closed from the point where the props no longer hold the hood open.

### WARNING!

To prevent possible damage, do not slam the hood to close it. Make sure hood is fully closed. Never drive vehicle unless hood is fully closed **and latched**.

### CAUTION!

To prevent possible damage, do not slam the hood to close it. Lower hood to approximately 10 - 14 inches (30 - 36 cm) and drop the hood to close. Make sure hood is fully closed and latched. Never drive vehicle unless hood is fully closed, and latched.

## LIFTGATE

### To UNLOCK/OPEN THE LIFTGATE

The power liftgate may be opened by pushing the liftgate button on the key fob, or by pushing the electronic liftgate release handle → page 29.

Push the liftgate button on the key fob twice within five seconds to open the power liftgate.

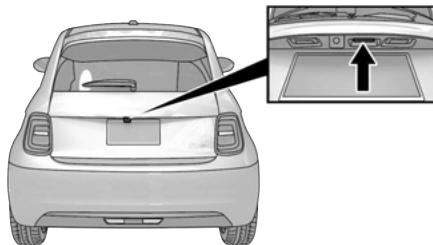

0222202541US

### Electronic Liftgate Release Handle

When opening the door, the interior dome light will illuminate. The interior dome light will turn off automatically by closing the liftgate → page 40.

### Emergency Opening

Should the vehicle's 12 V battery be depleted completely or if the electronic lock is defective, proceed as follows:

1. Lower or remove the rear head restraints and fold the seatbacks.

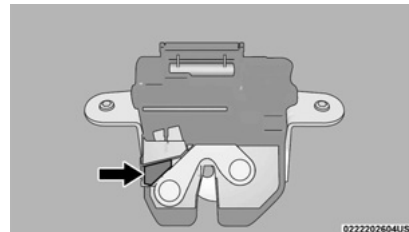

0222202604US

### Yellow Tab

2. Using the supplied screwdriver (located under cargo floor in tool kit), remove the yellow tab from the liftgate latching mechanism.
3. With the yellow tab removed, insert the screwdriver into the now open release tab slot to trigger the release of the liftgate.



## LOCK/CLOSE THE LIFTGATE

Grab the liftgate closing handle and lower the liftgate.

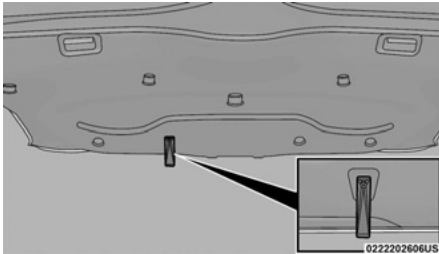

Liftgate Closing Handle

### NOTE:

Before closing the liftgate, make sure to be in possession of the key fob because the liftgate will be locked automatically.

## CARGO AREA FEATURES

### Cargo Box

Additional storage can be found under the storage lid. To access the lower storage, lift the handle and raise the storage lid.

### NOTE:

The cargo box is sized for a maximum capacity of distributed weight equal to 242 lb (110 kg).

### Cargo Cover

The cargo area contains a removable cover for privacy.

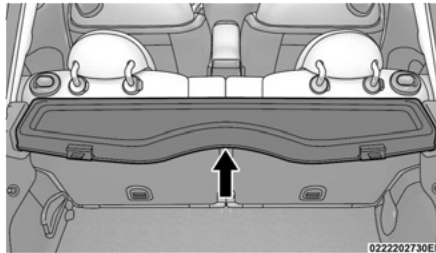

Cargo Cover

# GETTING TO KNOW YOUR INSTRUMENT PANEL

## INSTRUMENT CLUSTER

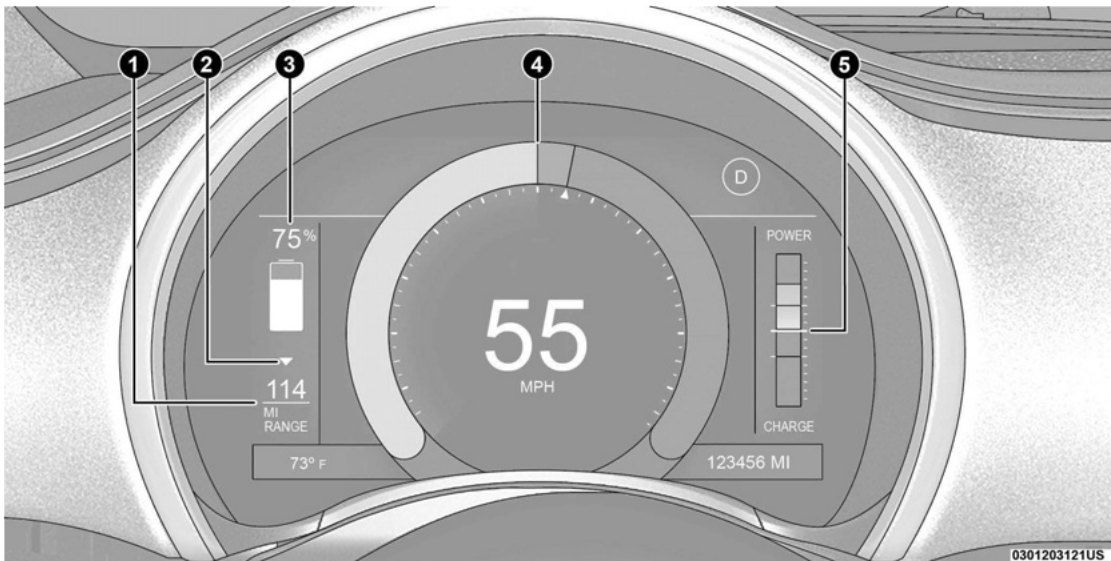

Use this QR code to access your digital experience.



## INSTRUMENT CLUSTER DESCRIPTIONS

### 1. Range

- Range to empty.

### 2. Range Trend Indicator

- The Range Trend Indicator displays a blue up or red down arrow indicating a higher or lower forecasted range considering your most recent driving style. A colored line will also appear under range to empty.

The absence of this indicator could indicate you are either parked, charging or your range trend is approximately equal to the forecasted range.

### 3. Battery Level Gauge

- Indicates the current battery level.

### 4. Speedometer

- Indicates vehicle speed.

### 5. Power/Eco/Charge Gauge

- Indicates current energy management. The red upper half of the gauge indicates the current

amount of battery power being applied to move the vehicle. The light red and light blue near the mid section of the gauge represents Eco Mode, which conserves energy. The bottom blue half indicates when the battery is charging via regenerative braking, while slowing the vehicle down.

## INSTRUMENT CLUSTER DISPLAY

Your vehicle is equipped with an instrument cluster display, which offers useful information to the driver. With the ignition in the OFF position, opening/closing of a door will activate the display for viewing, and display the total miles, or kilometers, in the odometer. The instrument cluster display is designed to display important information about the vehicle's systems and features. Using a driver interactive display located on the instrument panel, your instrument cluster display can show you how systems are working and give you warnings when they are not. The steering wheel mounted controls allow you to scroll through and enter the main menus and submenus. You can access the specific information you want and make selections and adjustments.

## LOCATION AND CONTROLS

The instrument cluster display features a driver interactive display that is located in the instrument cluster.

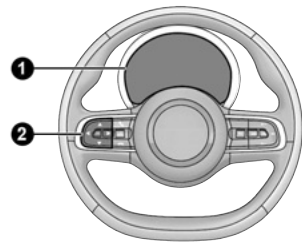

0301203142US

3

### Instrument Cluster Display and Controls

- 1 – Instrument Cluster Display Screen
- 2 – Instrument Cluster Display Controls

This system allows the driver to select a variety of useful information by pushing the switches mounted on the instrument panel. Examples of menu items are:

- Buzzer Volume
- Exit Menu

If equipped with a Uconnect system, some customer programmable features will display in the radio → page 113.

The system allows the driver to select information by pushing the following buttons mounted on the instrument panel to the left of the steering column:

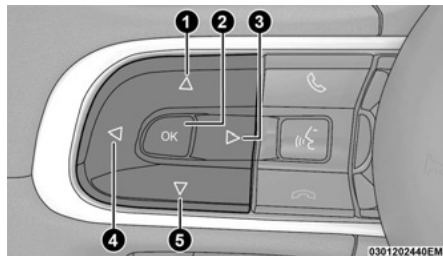

**Instrument Cluster Display Control Buttons**

- 1 – Up Arrow Button
- 2 – OK Button
- 3 – Right Arrow Button
- 4 – Left Arrow Button
- 5 – Down Arrow Button

#### ● **Left Arrow Button**

Push and release the **left** ◀ arrow button to scroll leftward through the main menu and submenus.

#### ● **Up Arrow Button**

Push and release the **up** ▲ arrow button to access the information screens or submenu screens of a main menu item.

#### ● **Right Arrow Button**

Push and release the **right** ▶ arrow button to scroll rightward through the main menu and submenus.

#### ● **Down Arrow Button**

Push and release the **down** ▼ button to access the information screens or submenu screens of a main menu item.

#### ● **OK Button**

Push the **OK** button to access/select the information screens or submenu screens of a main menu item.

Push and hold the **OK** button for one second to reset displayed/selected features that can be reset.

### STOP SAFELY VEHICLE WILL SHUT OFF SOON



#### Stop Safely Vehicle Will Shut Off Soon Warning Message

This warning will be displayed on the instrument panel display when the vehicle has determined an operational issue will occur shortly, which will cause the vehicle's propulsion system to turn off. If this message appears while driving, stop the vehicle in a safe location as soon as possible. Have the vehicle transported to an authorized dealer.

- This is a high priority message
- This message will be displayed continuously
- Cannot be cleared with button press
- A single chime will sound

### FIRE DANGER! PULL OVER NOW! EXIT QUICKLY!



#### Fire Danger! Pull Over Now! Exit Quickly! Warning Message

A warning will appear on the instrument panel display if the system detects the high voltage battery has overheated. This can result in a vehicle fire, and the release of toxic and/or flammable gases. To reduce the risk of a larger fire, the vehicle's high voltage propulsion system will turn off within thirty seconds of displaying this warning. At that time, the vehicle may not accelerate. You can still steer and brake the vehicle. This high priority message

- displays continuously.
- cannot be cleared with a button press.
- has a rapid and continuous chime.

Stop and park the vehicle in an open area. Have all passengers exit the vehicle as soon as possible and move to a safe distance away from the vehicle. After all passengers safely exit the vehicle, call emergency responders immediately. Even if you do not see flames, a fire may start at any moment. Do not attempt to reenter or start the vehicle.

## INSTRUMENT CLUSTER DISPLAY MAIN MENU

The Main Menu is composed of several options that can be selected by using the control buttons.

### NOTE:

- The display mode of the menu items varies depending on the type of display.
- For some items, a submenu is provided.
- If equipped with a Uconnect system, some customer programmable features and menus will display in the radio and not on the instrument cluster display.  page 57.

## Home Screen

The Home Screen has two view options to choose from.

- Enhanced Speedometer
  - This option features an large enhanced bar graph speedometer to visually represent current speed. When a speed control system is active, the graph also provides visual cues for the different states of that particular speed control system.
- Power/Eco/Charge Indicator

This option features a large round bar graph which displays a visualization of the current energy management, similar to the Power/Eco/Charge Gauge.

- “POWER”: Represent the current amount of battery power being applies to move the vehicle.
- “ECO”: Eco Mode, indicates energy-saving driving.
- “CHARGE”: Charge mode, indicates when regenerative braking is being used to both charge the battery and slow the vehicle.

## Trip

This instrument cluster display menu item allows you to view and select information about the “Trip Computer”:

- Trip A/Trip B
  - View instant consumption (mi/kWh, km/kWh, kWh/100km, kWh/mi, or MPGe).
  - View average consumption (mi/kWh, km/kWh, kWh/100km, kWh/mi, or MPGe).
  - View Trip distance (miles or km).
  - View average speed (mph or km/h).
  - View travel time (hours/minutes/seconds).
  - Reset instructions.



## Driver Assist — If Equipped

This menu item shows messages, statuses, and visual indications for the following driving aid systems:

- ACC (Adaptive Cruise Control)

- Lane Control
- TSR (Traffic Sign Recognition)
- ISA (Intelligent Speed Assist)
- Co-Driver with Follow to Stop or Co-Driver with Stop&Go

## Vehicle Info

Push **up**  or **down**  arrow button to scroll through the following information displays:

- Tire pressure
  - Indicates the inflation state of each tire.
  - Hold the OK button to perform reset procedure.
- Service (Scheduled Servicing)

## Audio

This menu item allows you to view the instrument cluster display and the information present on the display of the Uconnect system.

The information displayed is:

- “Radio (AM or FM)”: view Radio Station Name (if equipped), frequency, and graphical icon.
- AUX: Title display or song number playing.
- USB: Title display or song number playing.
- Ipod: Display the song title and graphic element.
- Bluetooth®: Displays the song title and a graphic element.
- DAB: Title display or song number playing.

- SAT/SXM (if equipped): displays the station name and a graphic element.
- APP: Displays strings and a graphic element.
- CarPlay®/Android Auto®/Amazon Alexa®: displays strings and a graphic element.
- Clear Audio Infocode: Displays blank screen.
- MUTE: Displays a graphic element.

## Phone

This menu displays the current status of a phone connected to the vehicle via Bluetooth®.

If no phone is connected, the menu will not function when the **OK** button is pushed. Otherwise, if a phone is connected, push the **OK** button to enter the menu. The following items will display:

- Recent calls: displays a short list of previous calls.
- SMS reader: displays a short list of previous text messages and if they are read or unread.
- Favorite numbers: displays a maximum of 10 favorite numbers.

## Navigation

If activated, this menu item will display navigation status and directions. User can choose two different layouts with the contextual menu:

- Pictograms
  - Distance to next maneuver.
  - Name of the street.
  - Turn-by-turn indication.

- Map
  - Zoom in and out by pressing up/down arrows.

## Messages (Stored)

This menu item allows you to display the information messages/ malfunction stored.

In case one or more new message are stored while user is viewing an ambient different from Stored Messages, in the menu bar a small badge should appear next to Stored Message miniature with the number of recently stored messages.

## Tutorials

The tutorial function is available on the vehicle to obtain essential information on some of its features.

The tutorials also proved tips in the form of pop-ups shown on the instrument panel display during the journey.

Tutorial

- Display Tips
  - Electric Features
  - Safety and Assist
  - Other Features
- Stored Tips
- Slideshow

## Settings — If Equipped

This menu item allows you to change the settings for the following:

- **Display**
- **Units**
- **Clock and Date**
- **Security**
- **Safety and Assistance**
- **Mirrors & Wipers**
- **Lights**
- **Brakes**
- **Doors and Locks**
- **Charging Schedule**
- **Start Pairing Process**
- **Engine OFF Procedure**

### Display

By selecting "Display", you can access the following settings:

- Screen Setup: Allows you to configure the display screen.
- EV Contents: Allows you to select "On" or "Off" for READY popup, Power/Charge gauge, Key-on/Key-off sounds and EV external sounds.
- Tutorial pages visualization: Allows you to select "On" or "Off".

- **Language:** Allows you to select the language in which to display the information/warnings.
- **Instrument Cluster Backlight:** Allows you to increase/decrease the brightness from level 1 to 8.
- **Automatic Reset Trip B:** Allows you to set the options to reset the Trip B (never, always, every two hours or every eight hours).
- **Phone Repetition:** Allows you to select "On" or "Off". The instrument cluster display can also display the information concerning phone mode. The information that can be displayed is the connection status of the mobile phone (phone connected or disconnected), the active telephone calls/incoming/on hold, and the management of double calls (first incoming second waiting, etc.).
- **Navigation Repetition:** Allows you to select "On" or "Off" on the instrument cluster display, information relating to the navigation mode.

### Units

By selecting the item "Units Of Measure", you can select the unit of measure used in the display.

Possible options are:

- US
- Metric
- Custom

### Clock And Date

By selecting the item "clock and date", you can adjust the clock.

Possible options are:

- **Set Time:** Adjust hours/minutes.
- **Set Format:** Adjust the time format "12h" (12 hours) or "24h" (24 hours).
- **Set Date:** Adjust day/month/year.

### Security

By selecting the item "Security", you can make the following adjustments:

- **Passenger Airbag:** Activation/Deactivation of the passenger airbag.
- **Speed Warning:** Set the vehicle speed limit (mph or km/h), which the driver is notified through a visual and acoustic signaling (display of a message and a symbol on the display).
- **Seat Belt Buzzer:** This function is only viewable when the Seat Belt Reminder (SBR) system is active.

### Safety And Assistance

By selecting the item "Safety & Assistance", you can make the following adjustments:

- **Warning Buzzer Volume:** Increase or decrease the volume of the buzzer by selecting "Off", "Low", "Medium", or "High".
- **LaneSense Warning — If Equipped:** A selection of the "readiness" of intervention of LaneSense.
- **LaneSense Strength — If Equipped:** Increase or decrease the lanesense strength by selecting "Low", "Medium", or "High".
- **Intelligent Speed Assist:** A selection of the type of function provided by the system (confirmation or automatic).

- **Traffic Sign Recognition:** Allows you to select "On" or "Off".
  - **Traffic Sign Recognition Warning:** A selection of the type of information of the warning (Off, Visual or Visual and Chime).
  - **New Speed Zone Detection:** A selection of the type of information of the detection (Off, Visual or Visual and Chime).
  - **Autonomous Emergency Braking (AEB)/Forward Collision Warning:** A selection of the type of information of the warning (Off, Only Warning or Warning and Active Braking).
  - **AEB/Forward Collision Sensitivity:** Increase or decrease the sensitivity of the system by selecting "Near", "Medium", or "Far".
  - **Park Assist:** A selection of the type of information provided by Park Assist.
  - **Park Assist Vol.:** A selection of the volume of acoustic signals provided by Park Assist.
  - **Attention Assist/Drowsy Driver Alert:** Enabling/Disabling the alert.
  - **Blind Spot Assist:** Off, Lights, Lights and Chime.
- ### Mirrors & Wipers
- By selecting the item "Mirrors & Wipers", you can make the following adjustments:
- **Rain Sensing Auto Wipers:** Enabling/disabling the automatic operation of wipers in the event of rain.

## Lights

By selecting the item "Lights", you can make the following adjustments:

- **Headlight Sensitivity:** Adjust the sensitivity of headlight brightness.
- **Interior Ambient Lights:** Increase or decrease the brightness of the Interior Ambient Lights.
- **Greeting Lights:** Enable/disable the vehicle's Greeting Lights.
- **Auto High Beam:** Activate/deactivate the automatic main beam headlights — If Equipped.
- **Daytime Running Lights:** Activate/deactivate the daytime running lights.
- **Cornering Lights:** Activate/deactivate the cornering lights — If Equipped.
- **Headlight Off Delay:** Set the delay for headlight shutoff after engine shutoff.

## Brakes

By selecting the item "Brakes", you can make the following adjustments:

- **Hold'n Go:** Allows you to select "On" or "Off".
- **Brake Service:** Enables a special procedure.
- **Auto Park Brake:** Enable/disable auto-insertion of the Electric Parking Brake.

## Doors And Locks

By selecting the item "Doors & Locks", you can make the following adjustments:

- **Auto Door Lock:** Activate/deactivate the automatic locking of the doors with the vehicle moving.

- **Auto Unlock On Exit:** Automatic unlocking of the doors when exiting the vehicle.
- **Flash Light With Lock:** Activate the direction indicators when closing the doors.
- **Sound Horn With Lock:** Activate/deactivate the horn when pushing the lock button on the Remote Keyless Entry. The options are "Off," "First Press," and "Second Press."
- **Remote Door Unlock Without Passive Entry:** Allows you to choose whether to unlock all the doors or only the driver's side door on the first push of the unlock button on the Remote Keyless Entry.
- **Passive Entry — If Equipped:** Activate the automatic locking of the doors.

## Charging Schedule

By selecting the item "Charging Schedule", you can make the following adjustments:

- **Set Schedule:** Set the charging schedule for weekends or weekdays.
- **Activate Schedule:** Activate/deactivate the charging schedule.
- **Set Power Level:** Adjust the power level of the charge.

## Start Pairing Process

### Engine OFF Procedure

Allows you to turn off the engine from the instrument cluster in the event of an ignition switch failure. Instructions for turning off the engine via the instrument cluster display controls will display in the instrument cluster.

## WARNING LIGHTS AND MESSAGES

The warning/indicator lights will illuminate in the instrument panel together with a dedicated message and/or acoustic signal when applicable. These indications are indicative and precautionary and as such must not be considered as exhaustive. Always refer to the information in this chapter in the event of a failure indication. All active telltales will display first if applicable. The system check menu may appear different based upon equipment options and current vehicle status. Some telltales are optional and may not appear.

## RED WARNING LIGHTS

### Air Bag Warning Light



This warning light will illuminate to indicate a fault with the air bag, and will turn on for four to eight seconds as a bulb check when the ignition is placed in the ON/RUN

position. This light will illuminate with a single chime when a fault with the air bag has been detected, it will stay on until the fault is cleared. If the light is either not on during startup, stays on, or turns on while driving, have the system inspected at an authorized dealer as soon as possible.

### Brake Warning Light



This warning light monitors various brake functions, including brake fluid level and parking brake application. If the brake light turns on it may indicate that the parking

brake is applied, that the brake fluid level is low, or that there is a problem with the Anti-Lock Brake System reservoir.



If the light remains on when the parking brake has been disengaged, and the fluid level is at the full mark on the master cylinder reservoir, it indicates a possible brake hydraulic system malfunction or that a problem with the Brake Booster has been detected by the Anti-Lock Brake System (ABS) / Electronic Stability Control (ESC) system. In this case, the light will remain on until the condition has been corrected. If the problem is related to the brake booster, the ABS pump will run when applying the brake, and a brake pedal pulsation may be felt during each stop.

The dual brake system provides a reserve braking capacity in the event of a failure to a portion of the hydraulic system. A leak in either half of the dual brake system is indicated by the Brake Warning Light, which will turn on when the brake fluid level in the master cylinder has dropped below a specified level.

The light will remain on until the cause is corrected.

**NOTE:**

The light may flash momentarily during sharp cornering maneuvers, which change fluid level conditions. The vehicle should have service performed, and the brake fluid level checked.

If brake failure is indicated, immediate repair is necessary.

**WARNING!**

Driving a vehicle with the red brake light on is dangerous. Part of the brake system may have failed.

*(Continued)*

**WARNING!**

It will take longer to stop the vehicle. You could have a collision. Have the vehicle checked immediately.

Vehicles equipped with the Anti-Lock Brake System (ABS) are also equipped with Electronic Brake Force Distribution (EBD). In the event of an EBD failure, the Brake Warning Light will turn on along with the ABS Light. Immediate repair to the ABS system is required.

Operation of the Brake Warning Light can be checked by turning the ignition switch from the OFF position to the ON/RUN position. The light should illuminate for approximately two seconds. The light should then turn off unless the parking brake is applied or a brake fault is detected. If the light does not illuminate, have the light inspected by an authorized dealer.

The light also will turn on when the parking brake is applied with the ignition switch in the ON/RUN position.

**NOTE:**

This light shows only that the parking brake is applied. It does not show the degree of brake application.

### Battery Charge Warning Light



This warning light will illuminate when the 12V battery is not charging properly. If it stays on, there may be a malfunction with the battery or charging system. Contact an authorized dealer as soon as possible.

This indicates a possible problem with the electrical system or a related component.

### Door Open Warning Light



This indicator will illuminate when the respective door is ajar/open and not fully closed.

**NOTE:**

If the vehicle is moving, there will also be a single chime.

### Drowsiness Detected Warning Light



Driver drowsiness detection helps to avoid crashes caused by fatigue by advising drivers to take a break in time. Once Drowsy Driver is detected, A pop-up will display continuously until the driver presses the **OK** button to clear.

Once the pop-up message is cleared, it is stored until the condition is no longer true.

### E-Latch Fault Warning Light



This indicator will illuminate to indicate a failure of the respective door's locking system. Contact your authorized dealer to have the system repaired.

### Electric Power Steering (EPS) Fault Warning Light



This warning light will turn on when there's a fault with the EPS system → page 74.

**WARNING!**

Continued operation with reduced assist could pose a safety risk to yourself and others. Service should be obtained as soon as possible.

**Service Electrical System Warning Light**

This warning light will illuminate when service to the electrical system is needed. It will be accompanied by a message in the cluster. If the telltale stays on or continues

to come on, contact an authorized dealer as soon as possible.

**Hood Open Warning Light**

This warning light will illuminate when the hood is left open and not fully closed.

**Trunk Open Warning Light**

This indicator will illuminate when the trunk is open and not fully closed.

**Plug Status Fault Warning Light**

This warning light will illuminate when a plug status fault is detected (when vehicle not in motion). It will be accompanied by a cluster message indicating the type of fault.

You may receive one of the following messages if a fault is detected:

- “Service Charging System” – If you see this message, it is recommended to unplug and plug in again, or try a different charging station. If an issue continues, contact an authorized dealer to service your high voltage charging system.
- “Issue Detected Check External Charging Station” – If you see this message, the charging station may be powered off, having internal fault or being scheduled to charge later. It is recommended to try a different charging station. If an issue continues, then contact an authorized dealer.

**NOTE:**

- Older or non-compliant J1772 EVSE models may not support charging of this vehicle. If this vehicle does not charge, it may be connected to a non-compliant Level 2 EVSE, and will flash indicators. Please identify this failure to the site operator and/or EVSE provider.
- Before this vehicle can be driven, the EVSE Charging Cord must be disconnected from the vehicle.

**Seat Belt Reminder Warning Light**

When the ignition is first placed in the ON/RUN position, if the driver’s seat belt is unbuckled, a chime will sound and the light will turn on. When driving, if the driver or front passenger seat belt remains unbuckled, the Seat Belt Reminder Light will flash or remain on continuously and a chime will sound → page 143.

**SOS Battery Fault Warning Light – If Equipped**

This warning light will illuminate to signal a fault with the SOS Battery system. If the light stays on or comes on during driving, we recommend you drive to the nearest service center and have the vehicle serviced immediately.

**SOS Fault Warning Light – If Equipped**

The symbol appears to indicate a failure in the EU eCall system. In this case, an emergency call cannot be made. Contact your authorized dealer as soon as possible to have the system repaired.

**Traction Battery Fault Warning Light**

This light alerts the driver that there is a failure in the Traction Battery System. Contact an authorized dealer if illumination persists.

**Low High-Voltage Battery State Of Charge**

The symbol appears on the instrument panel display in case of low state of charge of the high-voltage battery, charge high-voltage battery.

**Transmission Fault Warning Light**

The warning light switches on when the ignition device is brought to the ENGINE position but it should switch off after a few seconds.

The warning light flashes, along with an acoustic warning, to indicate a transmission failure.

### Torque Limited Warning Light



This warning light illuminates when vehicle acceleration is limited due to a reduction in battery or electric motor performance.

Contact your authorized dealer for service if illumination persists.

## YELLOW WARNING LIGHTS

### Acoustic Vehicle Alerting System (AVAS) Fault Warning Light



This light alerts the driver that the AVAS system is not functioning properly. If the light stays on contact and authorized dealer for service.

### Anti-Lock Brake System (ABS) Warning Light



This warning light monitors the ABS. The light will turn on when the ignition is placed in the ON/RUN position and may stay on for as long as four seconds.

If the ABS light remains on or turns on while driving, then the Anti-Lock portion of the brake system is not functioning and service is required as soon as possible. However, the conventional brake system will continue to operate normally, assuming the Brake Warning Light is not also on.

If the ABS light does not turn on when the ignition is placed in the ON/RUN position, have the brake system inspected by an authorized dealer.

### Adaptive Cruise Control (ACC) Fault Warning Light – If Equipped



This warning light will illuminate to indicate a fault in the ACC system. Contact a local authorized dealer for service → page 79.

### Automatic High Beam Warning Light



This warning light switches on to report a failure of the automatic high beam headlights. Contact an authorized dealer.

### Blind Spot Detection System Failure



This warning light switches on to report a failure of the blind detection spot system. Contact an authorized dealer.

### Brake Failure



This warning light illuminates together with the same red warning light flashing in the event of a brake system failure or low brake fluid level. Contact an authorized dealer.

### Drowsiness Detected Warning Light



This warning light switches on to report a failure of the Drowsy Driver Detection device. Contact an authorized dealer.

### Electric Park Brake Failure Warning Light



This warning light will illuminate to indicate the Electric Park Brake is not functioning properly and service is required. Contact an authorized dealer.

### Electronic Stability Control (ESC) OFF Warning Light



This warning light indicates the ESC is off. Each time the ignition is switched to ON/RUN, the ESC system will be on, even if it was turned off previously.

### Electronic Stability Control (ESC) Active Warning Light



This warning light will indicate when the ESC system is Active. The ESC Indicator Light in the instrument cluster will come on when the ignition is placed in the ON/RUN position, and when ESC is activated. It should turn off within a few seconds. If the ESC Indicator Light remains on in the RUN position, a malfunction has been detected in the ESC system. If this warning light remains on after several ignition cycles, and the vehicle has been driven several miles (kilometers) at speeds greater than 30 mph (48 km/h), see an authorized dealer as soon as possible to have the problem diagnosed and corrected.

- The ESC OFF Indicator Light and the ESC Indicator Light come on momentarily each time the ignition is placed in the ON/RUN position.

- The ESC system will make buzzing or clicking sounds when it is active. This is normal; the sounds will stop when ESC becomes inactive.
- This light will come on when the vehicle is in an ESC event.

### Forward Collision Warning (FCW) Fault Light/Camera Blinded



This warning light will illuminate to indicate a fault in the Forward Collision Warning System or if a Camera is Blinded. Contact an authorized dealer for service.

### Immobilizer Fail / VPS Electrical Alarm Warning Light



This telltale will illuminate when the vehicle security system has detected an attempt to break into the vehicle.

#### NOTE:

After cycling the ignition to the ON/RUN position, the Vehicle Security Warning Light could illuminate if a problem with the system is detected. This condition will result in the engine being shut off after two seconds.

### Keyless System Failure Indicator Light



The telltale will illuminate in the event of keyless system failure.

Contact an authorized dealer as soon as possible.

### Low Washer Fluid Warning Light



This warning light will illuminate when the windshield washer fluid is low.

### Park Sensors System Failure



The telltale will illuminate when there is a fault in the parking sensors.

### Rain Sensor Failure Light



The telltale will illuminate in the case of failure of the automatic windshield wiper. Contact an authorized dealer as soon as possible.

### Service Lanesense Warning Light — If Equipped



This warning light will illuminate when the Lanesense system is not operating and requires service. Please see an authorized dealer.

### Service Required/Call For Service Warning Light



This warning light will illuminate when service is needed. A pop-up will appear in the display to signal the need for service. Contact an authorized dealer as soon as possible.

### Speed Limiter Failure



This warning light will illuminate to indicate a fault in the Speed Limiter system. Contact a local authorized dealer for service.

### Tire Pressure Monitoring System (TPMS) Warning Light



#### Low tire pressure

The warning light switches on constantly to indicate that the tyre pressure is lower than the recommended value, in order to guarantee long tire life and optical electrical energy consumption, or to indicate a slow loss of pressure.

In this way the iTPMS warns the driver that one or more tyres may be flat and probably punctured.

In this case it is advisable to restore the correct pressure value. Once the normal operating conditions of the car are restored, carry out the Tire reset procedure.

#### NOTE:

Do not continue driving with one or more flat tires as handling of the car may be compromised. Stop the car, avoiding sharp braking and steering.

#### ITPMS failure/ITPMS temporarily deactivated

The warning light flashes for about 75 seconds and then stays on constantly to indicate that the system is temporarily deactivated or faulty. The system goes back to normal operation when the operating conditions allow it. If this is not the case, carry out the Tyre

reset procedure after restoring the normal operating conditions.

If the malfunction warning persists, contact a Fiat Dealership as soon as possible.

#### WARNING!

If the system signals a pressure drop on a specific tire, it is recommended to check the pressure on all four tires. The iTPMS does not relieve the driver from the obligation to check the tire pressure every month; it is not to be considered a system to replace servicing or a safety system. Tire pressure must be checked with tires cold. Should it become necessary for whatever reason to check pressure with warm tires, do not reduce pressure even though it is higher than the prescribed value, but repeat the check when tires are cold.

#### CAUTION!

The iTPMS cannot indicate sudden tire pressure drops (for example when a tire bursts). In this case, stop the car, braking with caution and avoiding abrupt steering. The system only warns that the tire pressure is low: it is not able to inflate them. Insufficient tire inflation increases electrical energy consumption, reduces the tread duration and may affect your ability to drive safely.

### Traffic Sign Recognition (TSR) Fault Warning Light



This light will illuminate to indicate a TSR fault. Contact an authorized dealer if the light remains on after restarting vehicle.

### Traction Battery Cut-off Warning Light — If Equipped



This telltale will turn on to indicate the Traction Battery system is not functioning properly. Contact an authorized dealer if illumination persists.

### Twilight Sensor Fault Warning Light



This light will illuminate to indicate a failure of the Twilight sensor. Contact an authorized dealer.

### YELLOW INDICATOR LIGHTS

#### Exterior Lights Failure Indicator Light



The telltale will illuminate to indicate a failure on the following lights: Daytime Running Lights (DRLs) / parking lights / side lights / turn signal indicators / rear fog light / reversing light / brake lights / license plate lights.

The failure may be caused by a blown bulb, a blown protection fuse, or an interruption of the electrical connection. Replace the bulb or the relevant fuse. Contact an authorized dealer.

### Lane Keeping Assist OFF — If Equipped



This light will illuminate when the Active Lane Management system is switched OFF.

### Forward Collision Warning (FCW) OFF Indicator Light — If Equipped



This indicator light illuminates to indicate that Forward Collision Warning is off.

### Icy Road Condition Indicator Light



This light will illuminate during an icy road condition.

### Press Brake Pedal Indicator Light



This telltale will illuminate to indicate that the brake pedal must be pressed to enable starting.

### Rear Fog Indicator Light



This indicator light will illuminate when the rear fog lights are on.

### Traffic Sign Recognition (TSR) OFF Light



This light will illuminate when the TSR system is switched OFF.

## GREEN INDICATOR LIGHTS

### Adaptive Cruise Control (ACC) — If Equipped



This light will turn on when the Adaptive Cruise Control is ON. ⇨ page 79.

### Auto HOLD Indicator Light — If Equipped



Auto HOLD keeps your vehicle at a complete stop without you having to keep your foot on the brake pedal. Once engaged a green “HOLD” indicator will appear in the Instrument Cluster Display.

### Automatic High Beam Indicator Light — If Equipped



This indicator shows that the automatic high beam headlights are on ⇨ page 38.

### Cruise Control SET Indicator Light



This indicator light will illuminate when the Cruise Control system is ON ⇨ page 78.

### Intelligent Adaptive Cruise Control (ACC) — If Equipped



This light will turn on when the Intelligent Adaptive Cruise Control is ON. ⇨ page 79.

### Intelligent Speed System Assist — If Equipped



This light will turn on when the Intelligent Speed System Assist is ON.

### Park/Headlights On Indicator Light



This indicator light will illuminate when the park lights or headlights are turned on.

### Plugged In Indicator Light



This indicator will illuminate when the vehicle is plugged in.

### Ready To Drive Indicator Light



This indicator light will illuminate to indicate that the vehicle has enough power to be driven, regardless of the speed of the vehicle.

### Speed Limiter ON— If Equipped



This light will turn on when the Speed Limiter is ON.

### Turn Signal Indicator Lights



When the left or right turn signal is activated, the turn signal indicator will flash independently and the corresponding exterior turn signal lamps will flash. Turn

signals can be activated when the multifunction lever is moved down (left) or up (right).

#### NOTE:

- A continuous chime will sound if the vehicle is driven more than 1 mile (1.6 km) with either turn signal on.
- Check for an inoperative outside light bulb if either indicator flashes at a rapid rate.

## WHITE INDICATOR LIGHTS

### Adaptive Cruise Control READY (ACC) — If Equipped



This light will turn on when the Adaptive Cruise Control is READY. ⇨ page 79.

### Cruise Control READY Indicator Light



This light will turn on when the Cruise Control has been turned on, but not set ⇨ page 78.

### Intelligent Adaptive Cruise Control READY (ACC) — If Equipped



This light will turn on when the Intelligent Adaptive Cruise Control is READY. ⇨ page 79.

## Intelligent Speed Assist READY— If Equipped



The symbol appears when the Intelligent Speed Assist is READY.

## Speed Limiter Ready— If Equipped



The symbol appears to indicate that the Speed Limiter is READY.

## BLUE INDICATOR LIGHTS

### High Beam Indicator Light



This indicator light will illuminate to indicate that the high beam headlights are on.

With the low beams activated, push the multifunction lever forward (toward the front of the vehicle) to turn on the high beams. Pull the multifunction lever rearward (toward the rear of the vehicle) to turn off the high beams. If the high beams are off, pull the lever toward you for a temporary high beam on, "flash to pass" scenario.

# STARTING AND OPERATING

## STARTING THE VEHICLE

Before starting your vehicle, adjust your seat, adjust both inside and outside mirrors, and fasten your seat belts.

### WARNING!

- Never leave children alone in a vehicle, or with access to an unlocked vehicle.
- Allowing children to be in a vehicle unattended is dangerous for a number of reasons. A child or others could be seriously or fatally injured. Children should be warned not to touch the parking brake, brake pedal or the transmission push buttons.
- Do not leave the key fob in or near the vehicle (or in a location accessible to children). A child could operate power windows, other controls, or move the vehicle.
- Be sure the parking brake is fully disengaged before driving; failure to do so can lead to brake failure and a collision.
- Always fully apply the parking brake when leaving your vehicle, or it may roll and cause damage or injury.

## SINGLE SPEED TRANSMISSION

The transmission must be in the P (Park) position before you can start the vehicle. Apply the brakes when selecting a transmission gear from P (Park).

### NOTE:

You must press the brake pedal before selecting a transmission gear.

## NORMAL STARTING

The transmission must be in the P or N position before you can start the vehicle. Apply the brakes when selecting a transmission gear from P.

### NOTE:

You must press the brake pedal before selecting a transmission gear.

Proceed as follows:

1. The transmission must be in P (Park).
2. Press and hold the brake pedal while pushing the ON/RUN button once for a couple of seconds.
3. The READY indicator will appear in the instrument panel display when the vehicle is in Ready to Drive mode.

## ELECTRIC PARK BRAKE (EPB)

To apply the parking brake manually, pull up on the switch momentarily. You may hear a sound from the back of the vehicle while the parking brake engages. Once the parking brake is fully engaged, the BRAKE Warning Light in the instrument cluster and an indicator on the switch will illuminate. If your foot is on the brake pedal while you apply the parking brake, you may notice a small amount of brake pedal movement. The parking brake can be applied even when the ignition switch is OFF but the BRAKE Warning Light will not illuminate, however, it can only be released when the ignition is in the ON/RUN position.

### NOTE:

The EPB Warning Light will illuminate if the EPB switch is held for longer than 20 seconds in either the released or applied position. The light will extinguish upon releasing the switch.

If the Auto Park Brake feature is enabled, the parking brake will automatically engage whenever the transmission is placed into PARK. If your foot is on the brake pedal, you may notice a small amount of brake pedal movement while the parking brake is engaging.

The parking brake will release automatically when the ignition is ON, the transmission is in DRIVE or REVERSE, the driver seat belt is buckled, and an attempt is made to drive away.



To release the parking brake manually, the ignition switch must be in the ON/RUN position. Put your foot on the brake pedal, then push the EPB switch down momentarily. You may hear a sound from the back of the vehicle while the parking brake disengages. You may also notice a small amount of movement in the brake pedal. Once the parking brake is fully disengaged, the BRAKE Warning Light in the instrument cluster and the LED indicator on the switch will extinguish.

#### NOTE:

When parking on a hill, it is important to turn the front wheels toward the curb on a downhill grade and away from the curb on an uphill grade. Apply the parking brake before placing the gear selector in PARK, otherwise the load on the transmission locking mechanism may make it difficult to move the gear selector out of PARK.

#### WARNING!

- Never use the PARK position as a substitute for the parking brake. Always apply the parking brake fully when parked to guard against vehicle movement and possible injury or damage.
- When exiting the vehicle, always turn the ignition OFF, secure the key fob, and lock your vehicle.
- Never leave children alone in a vehicle, or with access to an unlocked vehicle. Allowing children to be in a vehicle unattended is dangerous for a number of reasons. A child or others could be seriously or fatally injured. Children should be

*(Continued)*

#### WARNING!

warned not to touch the parking brake, brake pedal or the gear selector.

- Do not leave the key fob in or near the vehicle, or in a location accessible to children, and do not leave a vehicle equipped with Keyless Enter 'n Go™ in the ON/RUN position. A child could operate power windows, other controls, or move the vehicle.
- Be sure the parking brake is fully disengaged before driving; failure to do so can lead to brake failure and a collision.
- Always fully apply the parking brake when leaving your vehicle, or it may roll and cause damage or injury. Also be certain to leave the transmission in PARK. Failure to do so may allow the vehicle to roll and cause damage or injury.

#### CAUTION!

If the Brake System Warning Light remains on with the parking brake released, a brake system malfunction is indicated. Have the brake system serviced by an authorized dealer immediately.

If exceptional circumstances should make it necessary to engage the EPB while the vehicle is in motion, maintain upward pressure on the EPB switch for as long as engagement is desired. The BRAKE Warning Light will illuminate, and a continuous chime will sound. The rear stop lamps will also be illuminated automatically while the vehicle remains in motion.

To disengage the parking brake while the vehicle is in motion, release the switch. If the vehicle is brought to a complete stop using the parking brake, when the vehicle reaches approximately 3 mph, (5 km/h) the parking brake will remain engaged.

#### WARNING!

Driving the vehicle with the parking brake engaged, or repeated use of the parking brake to slow the vehicle may cause serious damage to the brake system. Be sure the parking brake is fully disengaged before driving; failure to do so can lead to brake failure and a collision.

4

In the unlikely event of a malfunction of the EPB system, a yellow EPB Warning Light will illuminate. This may be accompanied by the BRAKE Warning Light flashing. In this event, urgent service of the EPB system is required. Do not rely on the parking brake to hold the vehicle stationary.

The electric parking brake may operate as follows:

- **Dynamic Operating Mode:** this mode is enabled by pulling the switch continuously while driving.
- **Static Engagement and Release Mode:** with the car stationary, the EPB can be activated by pulling the switch on the central console once. To disengage the EPB press the switch and the brake pedal at the same time.
- **Drive Away Release (If Equipped):** the EPB will automatically disengage with the driver side seat belt fastened and the detection of an action performed by the driver to move the car (forward gear or reverse gear)

- **Auto Park Brake:** if the vehicle speed is below 2 mph (3 km/h), the EPB will automatically engage when the transmission is in P (Park) position.
- **Safe Hold:** automatically engages the EPB if the vehicle is left unsecured while the ignition is in ON/RUN. The parking brake will automatically engage if all of the following conditions are met:
  - The vehicle is at a standstill.
  - There is no attempt to press the brake pedal or accelerator pedal.
  - The seat belt is unbuckled.
  - The driver door is open.

## SINGLE SPEED TRANSMISSION

Your vehicle uses a Single-Speed Transmission to direct the output from the electric motor. The single-speed transmission is operated using push-buttons instead of a traditional gear selector. The push-buttons are located on the lower dashboard.

### WARNING!

- Only place the transmission into gear when your foot is firmly pressing the brake pedal.
- Unintended movement of a vehicle could injure those in or near the vehicle. As with all vehicles, you should never exit a vehicle while the vehicle is in "READY" mode. Before exiting a vehicle, always apply the parking brake, shift the transmission into PARK, and remove the ignition key. Once

*(Continued)*

### WARNING!

the key is removed, the transmission is locked in PARK, securing the vehicle against unwanted movement.

- When leaving the vehicle, always remove the ignition key and lock your vehicle.
- Never leave children alone in a vehicle, or with access to an unlocked vehicle. Allowing children to be in a vehicle unattended is dangerous for a number of reasons. A child or others could be seriously or fatally injured. Children should be warned not to touch the parking brake, brake pedal or the transmission range buttons.
- Do not leave the ignition key in or near the vehicle (or in a location accessible to children). A child could operate power windows, other controls, or move the vehicle.

## GEAR RANGES

Push the desired button to shift into gear.

### NOTE:

- The brake pedal must be depressed to select a transmission gear.
- After selecting any gear, wait a moment to allow the selected gear to engage before accelerating.

## P (Park)

The P (Park) selection supplements the parking brake by locking the transmission. The vehicle can be started in this range. Never attempt to use P (Park) while the

vehicle is in motion. Apply the parking brake when exiting the vehicle in P (Park).

When parking on flat surfaces, you can first shift the transmission to P (Park) and then apply the parking brake.

When parking on sloping roads, apply the parking brake before shifting the transmission to P (Park). For added safety, turn the front wheels towards the kerb.

### NOTE:

Refer to the gear position shown on the instrument panel display and check that it indicates P (Park).

### NOTE:

- Never use the PARK position as a substitute for the park brake. Always apply the park brake fully when exiting the vehicle to guard against vehicle movement and possible injury or damage.
- Your vehicle could move and injure you and others if it is not in PARK. Check by trying to move the gear selector out of PARK with the brake pedal released.

Make sure the transmission is in PARK before exiting the vehicle.

- It is dangerous to shift out of PARK or NEUTRAL if your foot is not firmly pressing the brake pedal. The vehicle could accelerate quickly forward or in reverse. You could lose control of the vehicle and hit someone or something. Only shift the transmission into gear when your foot is firmly pressing the brake pedal.
- Unintended movement of a vehicle could injure those in or near the vehicle. As with all vehicles, you should never exit a vehicle while the engine is

running or the propulsion system is active. Before exiting a vehicle, always come to a complete stop, then apply the park brake, shift the transmission into PARK, turn the ignition OFF, and remove the key fob. When the ignition is in the OFF mode, the transmission is locked in PARK, securing the vehicle against unwanted movement.

- When leaving the vehicle, always remove the ignition key and lock your vehicle.
- Never leave children alone in a vehicle, or with access to an unlocked vehicle. Allowing children to be in a vehicle unattended is dangerous for a number of reasons. A child or others could be seriously or fatally injured. Children should be warned not to touch the parking brake, brake pedal or the transmission range buttons.
- Do not leave the ignition key in or near the vehicle (or in a location accessible to children). A child could operate power windows, other controls, or move the vehicle.

## R (Reverse)

The car can be moved backwards in this position. Select position R (Reverse) only with the car at a standstill.

## N (Neutral)

You can start the car with this gear engaged. Apply the parking brake and move the transmission to position P (Park) if you wish to exit the car.

### WARNING!

Do not coast in NEUTRAL and never turn off the ignition to coast down a hill. These are unsafe practices that limit your response to changing traffic or road conditions. You might lose control of the vehicle and have a collision.

### CAUTION!

Towing the vehicle, coasting, or driving for any other reason with the transmission in NEUTRAL can cause severe transmission damage. Refer to "Recreational Towing" in "Starting And Operating" and "Towing A Disabled Vehicle" in "In Case Of Emergency" for further information.

## D (Drive)

Use this gear driving in towns and on motorways.

## AUTO PARK

The function automatically put the transmission in P (Park) if there is any indication that the driver may leave the car while the transmission is in D (Drive), N (Neutral) or R (Reverse).

### Operation with the ignition device to the ON/RUN position

The Auto Park function is activated when the transmission is in position D (Drive), N (Neutral) or R (Reverse) and the following conditions are detected:

- Seat belt not fastened
- Brake pedal released

- Accelerator pedal released
- Driver's door open
- Car speed is below 3 km/h (2 mph).

### Operation with the ignition device to the OFF position

The Auto Park function is activated when the transmission is in position D (Drive), N (Neutral) or R (Reverse), the car speed is less than 3 km/h and the user requests the car to be turned off by turning the ignition device to the OFF position.

### Gear engagement inhibition

This system prevents shifting the transmission from position P (Park) or N (Neutral) if the brake pedal has not been previously pressed. With ignition device in the ON/RUN position: the brake pedal must be pressed in order to shift the transmission from position P (Park) to positions R, N or D; to shift the transmission from position N (Neutral) to positions R or D the brake pedal must be pressed.

### Stopping the engine

The system automatically engages P (Park) when the car is shut down (ignition device in OFF position).

To stop the engine at speeds higher than 2.5 km/h hold the button of the ignition device pressed or press it three times in a row within a few seconds. The ignition device is in the ON/RUN position.

## E-MODE SELECTOR

The E-Mode Selector is an "hold to operate" type which returns to the central position when released. Engagement of the required driving mode is indicated on the instrument panel display with a dedicated message.

**NOTE:**

- The system does not allow you to change the driving mode when you drastically reduce the performance of the electric motor.
- When the motor is started, the system usually maintains the driving mode that was active before the vehicle was stopped.

The E-Mode Selector is located on the central console.

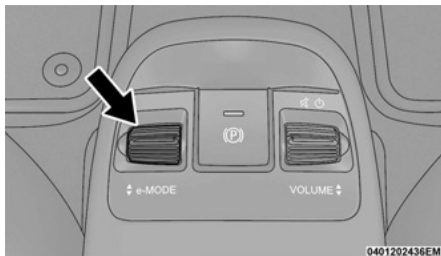

**E-Mode Selector**

The E-Mode Selector consists of the following operating modes:

**NORMAL Mode** – In this mode the vehicle has no performance limitations and can be driven fast using all the power and torque of the traction system. In this mode the energy consumption of the vehicle depends on the driving style.

**RANGE Mode** – In this mode the vehicle continues to have no speed restrictions but offers comfortable

handling with a smoother response to accelerator pedal pressure. This mode helps to adopt a driving style aimed at maximizing the range.

**SHERPA Mode** – In this mode the vehicle has no acceleration restriction but the top speed is electronically limited to 50 mph (80 km/h). This mode significantly helps to adopt a driving style aimed at maximum efficiency and maximizes the range of the vehicle. The climate control system and seat heaters are also automatically deactivated but can be manually reactivated if necessary.

## POWER STEERING

The electric power steering system will provide increased vehicle response and ease of maneuverability. The electric power steering system adapts to different driving conditions.

### WARNING!

Continued operation with reduced assist could pose a safety risk to yourself and others. Service should be obtained as soon as possible.

Alternate electric power steering efforts can be selected through the Uconnect system. Refer to "Customer Programmable Features" within "Uconnect Settings" in "Multimedia" for further information.



If the Electric Power Steering warning icon is displayed and the "Service Power Steering" or the "Power Steering Assist Off – Service System" message is displayed within the instrument cluster display, this indicates the vehicle needs to be taken to an authorized dealer for service.

Refer to "Warning Lights And Messages" in "Getting To Know Your Instrument Panel" for further information.

If the Electric Power Steering warning icon is displayed and the "Power Steering System Over Temp" message is displayed on the instrument cluster display, this indicates an over temperature condition in the power steering system. Once driving conditions are safe, pull over and let the vehicle idle for a few moments until the icon and message turn off.

**NOTE:**

- Even if the power steering assistance is no longer operational, it is still possible to steer the vehicle. Under these conditions there will be a substantial increase in steering effort, especially at low speeds and during parking maneuvers.
- If the condition persists, see an authorized dealer for service.

## ACTIVE SPEED LIMITER

The Active Speed Limiter button is positioned on the right side of the steering wheel.

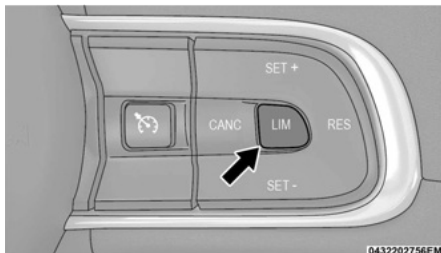

### Active Speed Limiter Button

This feature allows you to program the maximum speed of travel for your vehicle.

#### NOTE:

The Active Speed Limiter can be set with the vehicle stationary or in motion. The minimum speed it can be set to is 18 mph (30 km/h).

### ACTIVATION

To activate the feature, push the Active Speed Limiter button located on the right side of the steering wheel. A message will appear along with an indicator light in the instrument cluster display to signal that Active Speed Limiter has been activated.

#### NOTE:

If Cruise Control or Adaptive Cruise Control are active, press the Active Speed Limiter button twice. The first press will switch off the active function; the second press will activate the speed limiter.

After the Active Speed Limiter on/off button has been pushed, you must press the SET (+) or SET (-) button

to set the target speed (or RES button when there is already a previously set target).

Push the SET (+) or SET (-) button to raise or lower the target speed to the desired value, speed will increase/decrease by 1 mph (1 km/h). Pushing and holding down the SET (+) or SET (-) button will increase/decrease the speed value by increments of 5 mph (10 km/h).

Each time that Active Speed Limiter is activated, it will be set to the last programmed value from the previous activation.

#### NOTE:

The Cruise Control (if equipped) and Adaptive Cruise Control (if equipped) systems will be unavailable while the Active Speed Limiter is in use.

### EXCEEDING THE SET SPEED

By fully pressing the accelerator pedal, the programmed maximum speed can be exceeded while the device is active.

In the event that the Active Speed Limiter set value is exceeded manually with a driver acceleration, an audible indicator will sound. The indicator light will rapidly flash, and a message will appear in the instrument cluster display.

The feature will remain disabled until the vehicle speed drops below the set Active Speed Limiter value, where it will reactivate automatically.

### DEACTIVATION

To turn off Active Speed Limiter, push the Active Speed Limiter button on the right side of the steering wheel. A

message will appear in the instrument cluster display to confirm that the feature has been turned off. You can also deactivate Active Speed Limiter by pressing the CANCEL button. In this case, the system is not completely turned off, and the driver can reactivate the Active Speed Limiter by pressing the RES button.

#### NOTE:

In the event of a system failure, the Active Speed Limiter will switch off automatically and the indicator light will switch to grey. In this event, please see an authorized dealer.

## INTELLIGENT SPEED ASSIST (ISA)



The Intelligent Speed Assist (ISA) system combines the Active Speed Limiter and Traffic Sign Assist (TSA) systems to automatically adjust the maximum speed of the vehicle based on detected traffic signs.

The Active Speed Limiter can be set with the vehicle stationary or in motion. The minimum speed it can be set to is 18 mph (30 km/h).

### ACTIVATION

To activate the feature, make sure the Traffic Sign Assist (TSA) system is enabled within Uconnect Settings  page 113, then push the Active Speed Limiter button located on the right side of the steering wheel. The message "Ready" will appear along with a white indicator light in the instrument cluster display to signal that the system has been activated.

While the system is in the "Ready" state, the driver must press the SET (+), SET (-), or RES button to engage the system. When the system is fully engaged and detects the current speed limit using the TSA system, the message in the instrument cluster display will indicate the new detected speed limit by suggesting the driver to press "RES" to accept it.

If the detected speed sign is greater than the current set speed, an up arrow will be displayed too. If the detected speed sign is lower than the current set speed, a down arrow will be displayed instead. If the driver accepts the new suggested speed sign, the indicator light will change to green.

Pushing the SET (+) or SET (-) button on the right of the steering wheel will raise and lower the set speed to a desired value above or below the set ISA speed. Pushing and holding down the SET (+) or SET (-) button will increase/decrease the speed value by increments of 5 mph (5 km/h).

#### NOTE:

The Cruise Control (if equipped) and Adaptive Cruise Control (if equipped) systems will be unavailable while the ISA system is in use.

## EXCEEDING THE SET SPEED

By fully pressing the accelerator pedal, the maximum set speed can be exceeded while the system is active.

When the maximum set speed is exceeded, the green indicator light will blink and the instrument cluster display will show an override message for five seconds, or until the accelerator pedal is released.

## DEACTIVATION

The system can be deactivated under the following conditions. A message will appear in the instrument cluster display to confirm that the feature has been turned off.

- When the Active Speed Limiter Button is pressed.
- When the TSR system is deactivated.
- When the TSR system shows a new speed limit which is not confirmed by the driver.
- When the TSR system shows the end of a speed limit.
- When the TSR system cannot display any speed limit.

ISA can also be deactivated by pressing the CANC button. In this case, the ISA system is not completely turned off, and the driver can reactivate the system by pressing the RES button.

## TRAFFIC SIGN RECOGNITION SYSTEM

The Traffic Sign Recognition (TSR) system uses a camera mounted on the windshield, as well as map data when the vehicle is equipped with Navigation, to detect recognizable road signs such as:

- Speed limits
- Speed limits with restrictions
- No passing zones

#### NOTE:

- The TSR system will automatically display the road sign detected in the unit of measurement (mph or km/h) selected within Uconnect Settings or within the instrument cluster display.
- If no speed limit signs are detected, the system will revert to the speed limit signs that are stored in the Navigation system.
- The system always checks the traffic signs indicating the current speed limit signs. The system is able to recognize and display up to 3 different road signs in the instrument cluster display.
- The system will resume the last settings enabled when the engine is shut off and turned back on.

## ACTIVATION/DEACTIVATION

The TSR System can be enabled/disabled within the Uconnect system through the Safety/Driver Assistance menu. System ON is signaled by road signs shown on the instrument cluster display.

When the TSR system is turned OFF, the system will not show any traffic signs.

When the Speed Limiter or Adaptive Cruise Control is engaged, it will display the appropriate road speed limit (whether it's a standard limit or adjusted for rain/snow/foggy conditions). You can accept this displayed speed as the setting for Intelligent Speed Assist, or you can use it for Intelligent Adaptive Cruise Control by pressing the RES button.

#### NOTE:

The TSR system cannot provide an applicable speed limit in the following cases:



In case of system fault or unavailability, this indicator appears on the display.



If a Speed Limit Ends sign is recognized and if the navigation system (if equipped) is unable to provide a valid limit on the stretch of road. The “No Speed Limit” indicator will appear on the display.

## TRAFFIC SIGN RECOGNITION WARNING

### MODES

TSR warning has three selectable modes of operation that are available through the Uconnect system.

#### Visual

When Visual is selected, the system will alert the driver when the current speed of the vehicle exceeds the detected speed limit by showing a graphic in the instrument cluster display.

#### Visual + Chime

When Visual + Chime is selected, the system will alert the driver when the current speed of the vehicle exceeds the detected speed limit by showing a graphic in the instrument cluster display, and by sounding an audible alert. The visual alert will remain on as long as the vehicle is exceeding the speed limit.

#### NOTE:

Whenever an audible alert is requested by the TSR system, the radio is also muted.

#### Off

When TSR warning is turned off, the system will show any traffic signs, and no alerts will be issued to the driver.

## INDICATIONS ON THE DISPLAY

Detected traffic signs are shown in the instrument cluster display, and can display any combination of signs at one time (e.g. speed limit, speed limit and supplemental info, and “Do Not Pass” signs) depending on what information is available.

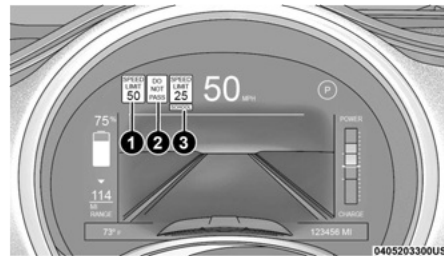

### Traffic Signs Recognized

- 1 — Current Speed Limit Detected
- 2 — No Passing Zone Detected
- 3 — Current Speed Limit With Supplemental Information (School Zone)

#### Supplemental Information

Supplemental information may be displayed along with a newly detected speed limit, indicating special circumstances of which the driver should be aware. Available supplemental information includes:

- School
- Construction
- Rain
- Snow
- Fog

#### Speed Limit Exceeded

When the vehicle speed exceeds the displayed speed limit by 3 mph (5 km/h), the speed limit sign on the instrument cluster display will show a red outline to alert the driver.

### CAUTION!

- Traffic Sign Assist is designed to assist the driver and is not a substitute for the driver. It is always the driver's responsibility to continue to monitor the speed limit and vehicle speed, and to operate the vehicle in a manner safe for the road conditions.
- Functionality may be limited or the system may not work if the sensor is obstructed.
- The system may have limited operation or not work at all in weather conditions such as heavy rain, hail, and thick fog. Strong light contrasts can influence the recognition capability of the sensor.
- The area surrounding the sensor must not be covered with stickers or any other object.

*(Continued)*

**CAUTION!**

- Do not tamper or perform any operations in the area of the windshield glass directly surrounding the sensor.
- Clean foreign matters such as bird droppings, insects, snow or ice on the windshield. Use specific detergents and clean cloths to avoid scratching the windshield.

**NAVIGATION SYSTEM INTEGRATION**

The TSR system combines the data captured by the camera with information from the navigation system. This integration allows it to offer default speed limits, such as the general speed limit on highways, and to complement camera-based road sign recognition with map data.

The navigation system communicates the measurement unit used in the country you're in and converts it to match your user-selected preference. This ensures that the speed limits suggested by the Intelligent Speed Assist system and the speeds provided by the Intelligent Adaptive Cruise Control system are always accurate, regardless of your chosen measurement unit.

The system can also display road signs in accordance with the current standards in the country you're traveling through. By leveraging the data in the navigator, the system can identify various scenarios, like highway, urban, and non-urban settings, and use the navigator's limits to provide the most accurate speed limits. Additionally, it can recognize curves and, when necessary, use the limit detected by the navigator instead of the one identified by the camera.

**CRUISE CONTROL SYSTEMS — IF EQUIPPED**

Your vehicle may be equipped with the Cruise Control system, or the Adaptive Cruise Control (ACC) system:

- Cruise Control will keep your vehicle at a constant preset speed.
- Adaptive Cruise Control (ACC) will adjust the vehicle speed up to the preset speed to maintain a distance with the vehicle ahead.

**NOTE:**

- In vehicles equipped with ACC, if ACC is not enabled, Fixed Speed Cruise Control will not detect vehicles directly ahead of you. Always be aware of the feature selected.
- Only one Cruise Control feature can operate at a time. For example, if Fixed Speed Cruise Control is enabled, Adaptive Cruise Control will be unavailable, and vice versa.

**CRUISE CONTROL**

When engaged, the Cruise Control takes over accelerator operations at speeds greater than 20 mph (30 km/h).

The Cruise Control buttons are located on the right side of the steering wheel.

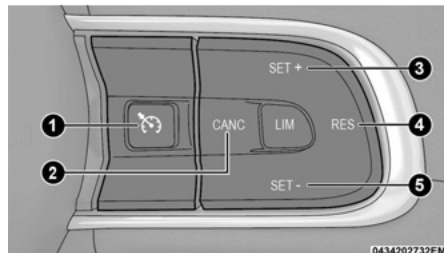
**Cruise Control Buttons**

- 1 — On/Off
- 2 — CANCEL/Cancel
- 3 — SET (+)/Accel
- 4 — RES/Resume
- 5 — SET (-)/Decel

**WARNING!**

Cruise Control can be dangerous where the system cannot maintain a constant speed. Your vehicle could go too fast for the conditions, and you could lose control and have an accident. Do not use Cruise Control in heavy traffic or on roads that are winding, icy, snow-covered or slippery.

**To Activate**

Push the on/off button to activate the Cruise Control. The symbol on the instrument panel switches on to signal that the device has been activated.

To turn the system off, push the on/off button a second time.



If the vehicle is equipped with Active Speed Limiter and the system is active, the Cruise Control button must be pressed twice. The first press will disable Active Speed Limiter and then second press will enable Cruise Control.

**NOTE:**

Cruise Control cannot be enabled if the vehicle is in the Reverse or Neutral driving positions.

**WARNING!**

Leaving the Cruise Control system on when not in use is dangerous. You could accidentally set the system or cause it to go faster than you want. You could lose control and have an accident. Always turn the system OFF when you are not using it.

**To Set A Desired Speed**

Turn the Cruise Control on.

When the vehicle has reached the desired speed, push and release the SET (+) or SET (-) button. Release the accelerator and the vehicle will operate at the selected speed. A Cruise Control Set Indicator Light, along with set speed will also appear and stay on in the instrument cluster when the speed is set.

If necessary, such as when passing another vehicle, you can accelerate by pressing the accelerator pedal. When you release the pedal, the car will return to the previously stored speed.

When driving downhill with the system active, the car's speed may temporarily go slightly above the set speed.

**NOTE:**

Before setting the desired speed, the car must first be travelling at a constant speed on a flat surface.

**To Vary The Speed Setting****To Increase Or Decrease The Set Speed**

When the Cruise Control is set, you can increase speed by pushing the SET (+) button, or decrease speed by pushing the SET (-) button.

**U.S. Speed (mph)**

- Pushing the SET (+), or SET (-) button once will result in a 1 mph speed adjustment. Each subsequent tap of the button results in an adjustment of 1 mph.
- If the button is continually pushed, the set speed will continue to adjust until the button is released, then the new set speed will be established.

**Metric Speed (km/h)**

- Pushing the SET (+), or SET (-) button once will result in a 1 km/h speed adjustment. Each subsequent tap of the button results in an adjustment of 1 km/h.
- If the button is continually pushed, the set speed will continue to adjust until the button is released, then the new set speed will be established.

**To Resume Speed**

To resume a previously set speed, push the RES button and release.

**To Deactivate**

A tap on the brake pedal, or pushing the CANCEL button, or normal brake pressure will deactivate the Cruise

Control system without erasing the set speed from memory.

The Cruise Control can also be turned off when the Electric Park Brake (EPB) is engaged, when the braking system kicks in (e.g. the ESC system), or in other particular conditions.

Pushing the on/off button or placing the ignition in the OFF position, will erase the set speed from memory.

**ADAPTIVE CRUISE CONTROL (ACC)**

Adaptive Cruise Control (ACC) increases the driving convenience provided by Cruise Control while traveling on highways and major roadways. However, it is not a safety system and not designed to prevent collisions.

**The Cruise Control function performs differently if your vehicle is not equipped with ACC → page 78.**

ACC will allow you to keep Cruise Control engaged in light to moderate traffic conditions without the constant need to reset your speed. ACC utilizes a radar sensor and a forward facing camera designed to detect a vehicle directly ahead of you to maintain a set speed.

**NOTE:**

- If the ACC sensor detects a vehicle ahead, ACC will apply limited braking or accelerate (not to exceed the original set speed) automatically to maintain a preset following distance, while matching the speed of the vehicle ahead.
- Any chassis/suspension or tire size modifications to the vehicle will affect the performance of the Adaptive Cruise Control and Forward Collision Warning system.

- Fixed Speed Cruise Control (ACC not enabled) will not detect vehicles directly ahead of you. Always be aware of the feature selected ➡ page 211.

**WARNING!**

- Adaptive Cruise Control (ACC) is a convenience system. It is not a substitute for active driver involvement. It is always the driver's responsibility to be attentive of road, traffic, and weather conditions, vehicle speed, distance to the vehicle ahead and, most importantly, brake operation to ensure safe operation of the vehicle under all road conditions. Your complete attention is always required while driving to maintain safe control of your vehicle. Failure to follow these warnings can result in a collision and death or serious personal injury.
- The ACC system:
  - Does not react to pedestrians, oncoming vehicles, and stationary objects (e.g., a stopped vehicle in a traffic jam or a disabled vehicle).
  - Cannot take street, traffic, and weather conditions into account, and may be limited upon adverse sight distance conditions.
  - Does not always fully recognize complex driving conditions, which can result in wrong or missing distance warnings.

You should turn the ACC system off:

*(Continued)*

**WARNING!**

- When driving in fog, heavy rain, heavy snow, sleet, heavy traffic, and complex driving situations (i.e., in highway construction zones).
- When entering a turn lane or highway off-ramp; when driving on roads that are winding, icy, snow-covered, slippery, or have steep uphill or downhill slopes.
- When towing a trailer up or down steep slopes.
- When circumstances do not allow safe driving at a constant speed.

**Adaptive Cruise Control (ACC) Operation**

The buttons on the right side of the steering wheel operate the ACC system.

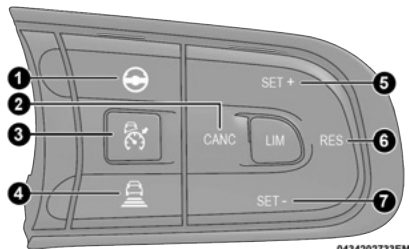

**Adaptive Cruise Control Buttons**

- 1 — Co-Driver On/Off Button
- 2 — CANCEL/Cancel
- 3 — Adaptive Cruise Control (ACC) On/Off
- 4 — Distance Increase/Decrease Button
- 5 — SET (+)/Accel
- 6 — RES/Resume
- 7 — SET (-)/Decel

**Adaptive Cruise Control (ACC) Menu**

The instrument cluster display shows the current ACC system settings. The information it displays depends on ACC system status.

Push the Adaptive Cruise Control (ACC) on/off button until one of the following shows in the instrument cluster display:

**Adaptive Cruise Control Off**

When ACC is deactivated, the display will read "Adaptive Cruise Control Off."

**Adaptive Cruise Control Ready**

When ACC is activated but the vehicle speed setting has not been selected, the display will read "Adaptive Cruise Control Ready."

**Adaptive Cruise Control Set**

When the SET (+) or the SET (-) button is pushed, the display will read "ACC SET."

When ACC is set, the set speed will appear in the instrument cluster display.

The ACC screen may display once again if any of the following ACC activity occurs:

- System Cancel
- Driver Override
- System Off
- ACC Proximity Warning
- ACC Unavailable Warning

The instrument cluster display will return to the last display selected after five seconds of no ACC display activity.

### Activating Adaptive Cruise Control (ACC)

The minimum set speed for the ACC system is 3 mph (5 km/h).

The maximum set speed is 90 mph (150 km/h).

When the system is turned on and in the ready state, the instrument cluster display will read "ACC Ready."

When the system is off, the instrument cluster display will read "Adaptive Cruise Control (ACC) Off."

#### NOTE:

You cannot engage ACC under the following conditions:

- When in 4WD Low
- When the brakes are applied
- When the parking brake is applied
- When the transmission is in PARK, REVERSE or NEUTRAL
- When the vehicle speed is below the minimum speed range
- When the brakes are overheated

- When the Electronic Stability Control (ESC), Anti-Lock Brake System (ABS), or other stability control systems are operating or have just operated
- During automatic braking by the Full Brake Control system (if equipped)
- When Cruise Control is activated

### To Activate/Deactivate

Push and release the Adaptive Cruise Control (ACC) on/off button. The ACC menu in the instrument cluster display will read "ACC Ready."

To turn the system off, push and release the Adaptive Cruise Control (ACC) on/off button again. At this time, the system will turn off and the instrument cluster display will read "Adaptive Cruise Control (ACC) Off."

#### WARNING!

Leaving the Adaptive Cruise Control (ACC) system on when not in use is dangerous. You could accidentally set the system or cause it to go faster than you want. You could lose control and have a collision. Always ensure the system is off when you are not using it.

### To Set A Desired Speed

When the vehicle reaches the speed desired, push the SET (+) button or the SET (-) button and release. The instrument cluster display will show the set speed.

While the accelerator pedal is pressed: a dedicated graphic with the symbol flashing will appear on the display for a few seconds; the system will not be able to control the distance between the car and the vehicle

ahead. In this case the speed will be determined only by the position of the accelerator pedal.

### To Cancel

The following conditions cancel the system:

- The brake pedal is applied.
- The CANC button is pushed.
- An Anti-Lock Brake System (ABS) event occurs.
- The gear selector is removed from the DRIVE position.
- The braking temperature exceeds normal range (overheated).
- The Electronic Stability Control, ABS, or other stability control system are in progress.
- The vehicle parking brake is applied.
- The driver switches ESC to Full Off mode.
- When the car speed is not within the settable speed range.
- When the Speed Limiter is active.
- An obstruction blocks the camera.

### To Turn Off

To turn off and erase the set speed memory by pressing the Adaptive Cruise Control (ACC) on/off button or by placing the vehicle in the OFF position.

### To Resume

If there is a set speed in memory, push the RES (resume) button and remove your foot from the

accelerator pedal. The instrument cluster display will show the last set speed.

Resume can be used at any speed above 0 mph (0 km/h) when ACC is active.

#### WARNING!

The Resume function should only be used if traffic and road conditions permit. Resuming a set speed that is too high or too low for prevailing traffic and road conditions could cause the vehicle to accelerate or decelerate too sharply for safe operation. Failure to follow these warnings can result in a collision and death or serious personal injury.

## To Vary The Speed Setting

### To Increase Or Decrease The Set Speed

After setting a speed, you can increase the set speed by pushing the SET (+) button, or decrease speed by pushing the SET (-) button.

### U.S. Speed (mph)

- Pushing the SET (+), or SET (-) button once will result in a 1 mph speed adjustment. Each subsequent tap of the button results in an adjustment of 1 mph.
- If the button is continually pushed, the set speed will continue to adjust in 5 mph increments until the button is released. The new set speed is reflected in the instrument cluster display.

### Metric Speed (km/h)

- Pushing the SET (+), or SET (-) button once will result in a 1 km/h speed adjustment. Each subsequent tap of the button results in an adjustment of 1 km/h.
- If the button is continually pushed, the set speed will continue to adjust in 10 km/h increments until the button is released. The new set speed is reflected in the instrument cluster display.

### NOTE:

When you override and push the SET (+) button or SET (-) button, the new set speed will be the current speed of the vehicle.

### When ACC Is Active

- When you use the SET (-) button to decelerate, if the engine's braking power does not slow the vehicle sufficiently to reach the set speed, the brake system will automatically slow the vehicle.
- The ACC system decelerates the vehicle to a full stop when following the vehicle in front. If your vehicle follows the vehicle in front to a standstill, after two seconds the driver will either have to push the RES (resume) button, or apply the accelerator pedal to reengage the ACC to the existing set speed.
- The ACC system maintains set speed when driving uphill and downhill. However, a slight speed change on moderate hills is normal. In addition, downshifting may occur while climbing uphill or descending downhill. This is normal operation and necessary to maintain set speed. When driving uphill and downhill, the ACC system will cancel if the braking temperature exceeds normal range (overheated).

## To Vary The Speed With Intelligent Adaptive Cruise Control

The Intelligent Adaptive Cruise Control system allows you to set a speed limit that matches the road sign detected by the Traffic Sign Recognition system  page 76. When a new speed limit is recognized, the TSR system will propose the new limit, and it will be displayed as a message on the instrument panel.

To accept the new limit, the driver can press the RES button to adjust the Adaptive Cruise Control speed to the speed suggested by the road sign.

The activation of the Intelligent Adaptive Cruise Control is indicated by the  indicator light on the display and a green circle around the speed limit sign.

## Setting The Following Distance In ACC

The specified following distance for ACC can be set by varying the distance setting between four bars (longest), three bars (long), two bars (medium) and one bar (short). Using this distance setting and the vehicle speed, ACC calculates and sets the distance to the vehicle ahead. This distance setting will show in the instrument cluster display.

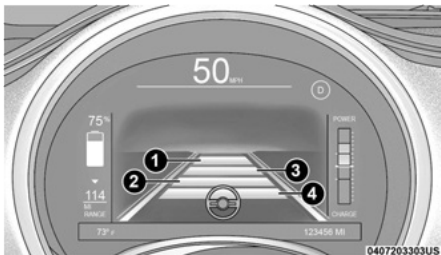

### Distance Settings

- 1 – Longest Distance Setting (Four Bars)
- 2 – Medium Distance Setting (Two Bars)
- 3 – Long Distance Setting (Three Bars)
- 4 – Short Distance Setting (One Bar)

To decrease the distance setting, push the Distance button and release. Each time the button is pushed, the distance setting decreases by one bar (shorter). Once the shortest distance has been reached, one more press of the button will set the longest distance. The set speed is held if there are no cars ahead.

If a slower moving vehicle is detected in the same lane, the instrument cluster display will show the ACC Set With Target Detected Light . The system will then adjust vehicle speed automatically to maintain the distance setting, regardless of the set speed.

The vehicle will then maintain the set distance until:

- The vehicle ahead accelerates to a speed above the set speed.

- The vehicle ahead moves out of your lane or view of the sensor.
- The distance setting is changed.
- The system disengages.

The maximum braking applied by ACC is limited; however, the driver can always apply the brakes manually, if necessary.

#### NOTE:

The brake lights will illuminate whenever the ACC system applies the brakes.

A Proximity Warning will alert the driver if ACC predicts that its maximum braking level is not sufficient to maintain the set distance. If this occurs, a visual alert “BRAKE!” will appear in the instrument cluster display and a chime will sound while ACC continues to apply its maximum braking capacity.

#### NOTE:

The “BRAKE!” screen in the instrument cluster display is a warning for the driver to take action and does not necessarily mean that the Full Brake Control system is applying the brakes autonomously.

### Overtake Aid

The Adaptive Cruise Control system, when traffic conditions allow, offers an additional burst of speed to aid in passing other vehicles. To use, activate the turn signal to signal your intention to overtake. This extra acceleration is provided as long as there's a safe distance between you and the vehicle you're passing.

Once you feel the acceleration, it's essential to ensure that it's safe to change lanes, taking into account the traffic and vehicles approaching from behind. After

making a clear path around other vehicles, the Adaptive Cruise Control will smoothly take over at your preset speed or reduce it to maintain your chosen following distance.

### ACC Operation At Stop

If the ACC system brings your vehicle to a standstill while following a vehicle ahead, your vehicle will resume motion, without any driver interaction, if the vehicle ahead starts moving within two seconds of your vehicle coming to a standstill.

If the target vehicle does not start moving within two seconds of your vehicle coming to a standstill, the ACC with Stop system will cancel and the brakes will release. A cancel message will display on the instrument cluster display and produce a warning chime.

When traveling at speeds below 36 mph (60 km/h) and with good visibility, the system can identify stationary vehicles and reduce speed to maintain a safe following distance. Once the car comes to a complete stop, ACC will turn off. You can reactivate the system when your speed is above 5 km/h (3 mph) by pressing any of the SET+, SET-, or RES buttons.

If the system keeps the vehicle stationary for two minutes, the electric parking brake will engage, and the system will be deactivated.

#### WARNING!

When the ACC system is resumed, the driver must ensure that there are no pedestrians, vehicles or objects in the path of the vehicle. Failure to follow

*(Continued)*

**WARNING!**

these warnings can result in a collision and death or serious personal injury.

## Speed Reductions On Bends

The Adaptive Cruise Control system has the capability to make slight speed reductions during bends to enhance vehicle stability and passenger comfort. This feature can be especially helpful in roundabouts or on gently curved roads where the curvature gradually increases. However, it cannot compensate for abrupt steering maneuvers or moderate-to-high lateral accelerations in general.

In scenarios where the traffic situation demands it, it is the drivers responsibility to apply the brakes, as needed, to further decrease the vehicle's speed, ensuring stability on tight bends or steep descents.

## Extension Of Adaptive Cruise Control: Co-Driver

The Adaptive Cruise Control system can operate in coordination with the Co-Driver system  page 87 to provide "Autonomous Level 2 Assistance." The Co-Driver is capable of maintaining a consistent speed and distance, adaptable to the vehicles ahead, and keeping the car centered within the lane.

**NOTE:**

This system is designed to assist the driver, who should always remain fully attentive while driving. The ultimate responsibility lies with the driver, who must consider the traffic conditions to ensure safe driving. The driver

should remain vigilant on the road and keep their hands on the steering wheel at all times.

## Display Warnings And Maintenance

### "FRONT RADAR SENSOR TEMPORARILY BLOCKED" WARNING

The "ACC Front Radar Sensor Temporarily Blocked" warning will display and a chime will sound when conditions temporarily limit system performance.

This most often occurs at times of poor visibility, such as in snow or heavy rain. The ACC system may also become temporarily blinded due to obstructions, such as mud, dirt or ice. In these cases, the instrument cluster display will read "ACC/FCW Unavailable Wipe Front Radar Sensor" and the system will deactivate.

The "ACC Front Radar Sensor Temporarily Blocked" message can sometimes be displayed while driving in highly reflective areas (i.e. ice and snow, or tunnels with reflective tiles). The ACC system will recover after the vehicle has left these areas. Under rare conditions, when the radar is not tracking any vehicles or objects in its path this warning may temporarily occur.

**NOTE:**

If the "ACC Front Radar Sensor Temporarily Blocked" warning is active, Fixed Speed Cruise Control is still available.

If weather conditions are not a factor, the driver should examine the sensor. It may require cleaning or removal of an obstruction. The sensor is located in the center of the vehicle behind the lower grille.

To keep the ACC System operating properly, it is important to note the following maintenance items:

- Always keep the sensor clean. Carefully wipe the sensor lens with a soft cloth. Do not use solvents or abrasive substances.
- Do not remove any screws from the sensor. Doing so could cause an ACC system malfunction or failure and require a sensor realignment.
- If the sensor or front end of the vehicle is damaged due to a collision, see an authorized dealer for service.
- Do not attach or install any accessories near the sensor, including transparent material or aftermarket grilles. Doing so could cause an ACC system failure or malfunction.

When the condition that deactivated the system is no longer present, the system will return to the "Adaptive Cruise Control Off" state and will resume function by simply reactivating it.

**NOTE:**

- If the "ACC Front Radar Sensor Temporarily Blocked" message occurs frequently (e.g. more than once on every trip) without any snow, rain, mud, or other obstruction, have the radar sensor realigned at an authorized dealer.
- Installing a snow plow, front-end protector, an aftermarket grille or modifying the grille is not recommended. Doing so may block the sensor and inhibit ACC/Full Brake Control System operation.

### "CLEAN FRONT WINDSHIELD" WARNING

The "ACC/FCW Limited Functionality Wipe Front Windshield" warning will display when conditions temporarily limit system performance. This most often

occurs at times of poor visibility, such as in snow or heavy rain and fog. The ACC system may also become temporarily blinded due to obstructions, such as mud, dirt, or ice on windshield and fog on the inside of glass. In these cases, the instrument cluster display will read “ACC/FCW Limited Functionality Wipe Front Windshield” and the system will have degraded performance.

The “ACC/FCW Limited Functionality Wipe Front Windshield” message can sometimes be displayed while driving in adverse weather conditions. The ACC/ Full Brake Control system will recover after the vehicle has left these areas. Under rare conditions, when the camera is not tracking any vehicles or objects in its path this warning may temporarily occur.

If weather conditions are not a factor, the driver should examine the windshield and the camera located on the back side of the inside rear view mirror. They may require cleaning or removal of an obstruction.

When the condition that created limited functionality is no longer present, the system will return to full functionality.

#### NOTE:

If the “ACC/FCW Limited Functionality Wipe Front Windshield” message occurs frequently (e.g. more than once on every trip) without any snow, rain, mud, or other obstruction, have the windshield and forward facing camera inspected at an authorized dealer.

#### SERVICE ACC/FCW WARNING

If the system turns off, and the instrument cluster display reads “ACC/FCW Limited Functionality Frontal Camera Service Required” or “Cruise Control Service Required”, there may be an internal system fault or a temporary malfunction that limits ACC functionality.

Although the vehicle is still drivable under normal conditions, ACC will be temporarily unavailable. If this occurs, try activating ACC again later, following an ignition cycle. If the problem persists, see an authorized dealer.

#### Precautions While Driving With ACC

In certain driving situations, ACC may have detection issues. In these cases, ACC may brake late or unexpectedly. The driver needs to stay alert and may need to intervene. The following are examples of these types of situations:

#### TOWING A TRAILER

Towing a trailer is not recommended when using ACC.

#### OFFSET DRIVING

ACC may not detect a vehicle in the same lane that is offset from your direct line of travel, or a vehicle merging in from a side lane. There may not be sufficient distance to the vehicle ahead. The offset vehicle may move in and out of the line of travel, which can cause your vehicle to brake or accelerate unexpectedly.

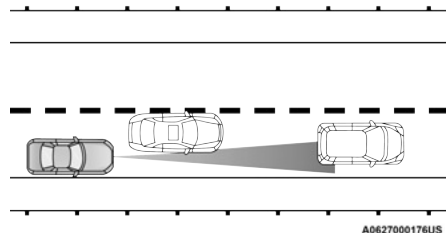

#### Offset Driving Condition Example

#### URNS AND BENDS

When driving on a curve with ACC engaged, the system may increase or decrease the vehicle speed for stability, with no vehicle ahead detected. Once the vehicle is out of the curve, the system will resume your original set speed. This is a part of normal ACC system functionality.

#### NOTE:

On tight turns ACC performance may be limited.

#### USING ACC ON HILLS

ACC performance may be limited when driving on hills. ACC may not detect a vehicle in your lane depending on the speed, vehicle load, traffic conditions, and the steepness of the hill.

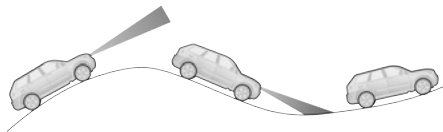

A0627000175US

ACC Hill Example

## LANE CHANGING

ACC may not detect a vehicle until it is completely in the lane in which you are traveling. In the following lane changing example, ACC has not yet detected the vehicle changing lanes and it may not detect the vehicle until it's too late for the ACC system to take action. ACC may not detect a vehicle until it is completely in the lane. There may not be sufficient distance to the lane-changing vehicle. Always be attentive and ready to apply the brakes if necessary.

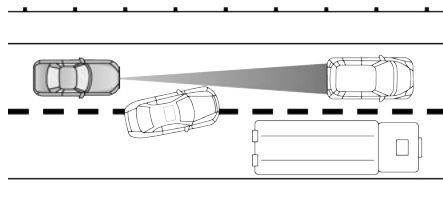

A0627000178US

Lane Changing Example

## NARROW VEHICLES

Some narrow vehicles traveling near the outer edges of the lane or edging into the lane are not detected until they have moved fully into the lane. There may not be sufficient distance to the vehicle ahead.

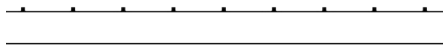

A0627000179US

Narrow Vehicle Example

## STATIONARY OBJECTS AND VEHICLES

ACC does not react to stationary objects or vehicles. For example, ACC will not react in situations where the vehicle you are following exits your lane and the vehicle ahead is stopped in your lane. It will consider this stopped vehicle a stationary object as it did not previously detect movement from it. Always be attentive and ready to apply the brakes if necessary.

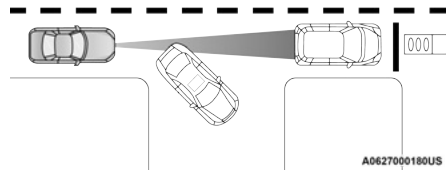

A0627000180US

Stationary Object And Stationary Vehicle Example

## OBJECTS AND VEHICLES MOVING IN OPPOSITE OR PERPENDICULAR DIRECTION

The system cannot detect objects or vehicles traveling in the opposite or perpendicular direction, and therefore will not activate.



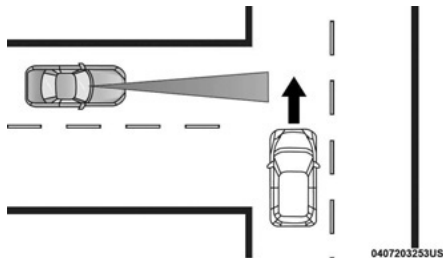

Objects Moving in Perpendicular Direction Example

## CO-DRIVER SYSTEM WITH FOLLOW TO STOP - TRAFFIC JAM ASSIST

The Co-Driver system combines the features of Active Cruise Control (ACC) and lane centering logic to control the trajectory of the car's path, maintaining it as close to the center of the lane as possible while also managing speed.

This driving assistance system can be activated on all types of roads.

The system information from the front camera to assist you in keeping the car steadily centered in the lane at a consistent speed.

### OPERATION

The system only works when the driver keeps their hands on the steering wheel. If the system senses that hands have been taken off the steering wheel, it will

notify you to place your hands back on the steering wheel.

#### NOTE:

The Co-Driver system can take a few seconds to activate once all conditions are met. During this time, a grey indication will appear on the instrument panel display and the system will be activated automatically as soon as all conditions are met, without any intervention by the driver.

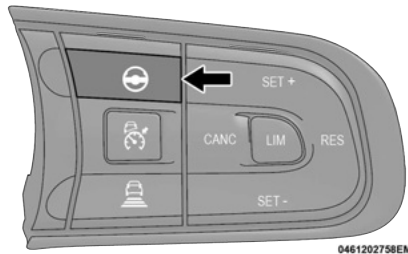

Co-Driver System On/Off Button

The following conditions must be met before the Co-Driver system turns on:

- Activate the Co-Driver system by pressing the  button on the steering wheel.
- Adaptive Cruise Control (ACC) must be in the ON.
- The vehicle speed must be between 35 mph and 90 mph (60 km/h and 150 km/h).
- Camera system functioning properly.
- Turn signals must not be activated.

- If the set speed is less than 35 mph (60 km/h) the Co-Driver system will not work;
- If the speed of Adaptive Cruise Control (ACC) can be set to a higher than a top speed of 90 mph (150 km/h), the Co-Driver feature will not be available.

### ACTIVATION AND DEACTIVATION

To activate the system, press the  button on the steering wheel.

To deactivate the system press the button again.

#### Suspension conditions

System operation are temporarily paused under the following scenarios:

- When the ACC system gets deactivated or inhibited  page 79.
- Tight bends in the road.
- If the lines on the road are not detected accurately.
- When one of the two lines on the road are is damaged or broken.
- When the sun is low, causing glare on the windshield camera.
- If the driver activates the left or right turn signal.
- When the driver intentionally switches lanes without using the corresponding turn signal.
- In the event of system irregularities.
- When the vehicle speed exceeds the maximum limit.
- If lateral acceleration becomes too high.

### Automatic deactivation

The Co-Driver system will automatically deactivate if you take your hands off the steering wheel for 45 seconds.

When the Co-Driver is paused the associated graphics in the designated area will turn grey.

When the steering wheel detects hands are on, the Co-Driver will be reactivated without any additional action needed from the driver.

#### WARNING!

It is dangerous to leave the device on when it is not used. There is a risk of inadvertently activating it and losing control of the car due to unexpected excessive speed.

### INDICATIONS ON THE DISPLAY

The system status can always be viewed through a dedicated area on the instrument panel display.

The system status is indicated by the color of the  symbol.

If the driver's hands are not on the steering wheel, a series of warnings will appear on the instrument panel display to alert the driver that he needs to reposition his hands on the steering wheel. Acoustic signals will also be emitted.

After a certain period of time, the Co-Driver system will be disabled if the driver has not repositioned their hands on the steering wheel.

When the system does not detect hands on the steering wheel for a few seconds, it will warn the driver by displaying a dedicated screen in the center of the instrument cluster display.

### SYSTEM STATUS

**System active:** A properly functioning system is verified by the display on the instrument panel. If hands are taken off the steering wheel, the system won't shut down immediately, only after a brief period: A series of dedicated screens will subsequently appear in succession on the instrument panel to remind the driver to place their hands back on the steering wheel.

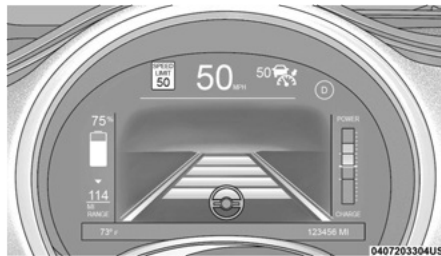

System Active



System Active — Yellow

**Hands removed from the steering wheel for a short time:** As soon as you take your hands off the steering wheel, the system will provide this warning on the instrument panel display. The system will remain active. If the driver doesn't reposition their hands on the steering wheel within a few seconds, the following message will appear on the instrument cluster display.



System Active — Red

**Hands removed from the steering wheel for a long time:**

If your hands aren't placed on the steering wheel, the screen will be displayed on the instrument cluster, along with an audible warning. If you fail to return your hands to the steering wheel after an extended duration, a deactivation message will show up on the instrument panel. Subsequently, the steering wheel control will be deactivated.

When the Co-Driver system is active, LaneSense (if equipped) takes a temporary pause. When the Co-Driver system is not in operation, LaneSense (if previously enabled) remains accessible. For additional details on the LaneSense system, see  page 106

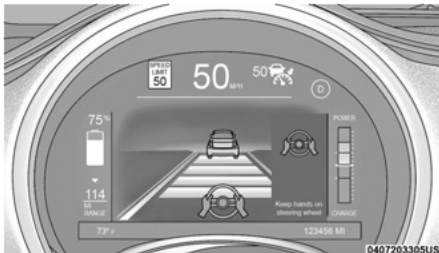

**System Deactivated**

## SYSTEM AVAILABILITY

External factors and conditions may affect the proper operation of the Co-Driver system.

Some of the primary factors include:

- Narrow, winding and curvy roads.

- Limited visibility (due to heavy rain, snow, fog, etc.).
- Glare from the headlights of oncoming vehicles, direct sunlight, or shade.
- Interference, damage, or blockages caused by mud, ice, snow, and similar obstructions.
- Interference from other equipment emitting electromagnetic waves.
- Presence of roadworks or road construction sites.
- If the indications given by the navigation system (if equipped) are not yet ready and/or if the navigation system is recalculating the route.

## SYSTEM OPERATION/LIMITATIONS

The Co-Driver system may experience limited or reduced functionality under the following conditions:

- Unclear or poorly visible lane marking lines, such as in heavy rain, snow, fog, etc.
- Damage, coverage, or obstruction of the camera, like by mud, ice, snow, etc.
- When driving in hilly terrain or on roads with sharp turns.
- In proximity to toll gates.
- When highway entrances or exits exceed 20 feet (6 meters) in width.
- When the camera is exposed to intense and blinding light, such as reflections or direct sunlight.

## CO-DRIVER SYSTEM WITH STOP & GO – ADAPTIVE CRUISE CONTROL WITH STOP & GO – IF EQUIPPED

### WARNING!

The device can take the vehicle to a standstill but the driver must always be ready to apply the brakes, if necessary.

The Adaptive Cruise Control with Stop & Go is a driver assistance feature that merges Cruise Control functions with distance control function from the vehicle in ahead.

This system enables the car to maintain the desired speed without requiring the driver to press the accelerator as well as maintain the distance set by the driver from the vehicle ahead.

The system uses a radar sensor, located behind the front bumper and a camera, located in the middle area of the windshield, to detect the presence of a vehicle close ahead.

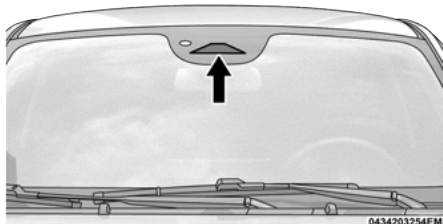

**Windshield Camera**

### Precautions

When the sensor doesn't detect any vehicle ahead, the system maintains a constant set speed. However, when the sensor detects a vehicle in front, the system intervenes automatically by slightly applying the brakes or accelerating as needed to prevent exceeding the preset speed. It aims to keep the preset distance and adjust to the speed of the vehicle ahead.

It's advisable to deactivate the system in the following situations:

- When driving in fog, heavy rain, snow, or under challenging driving conditions.
- When navigating winding roads, icy, snowy, slippery surfaces, or steep uphill or downhill slopes.
- When entering a turn lane or an off-ramp on the motorway.
- When the circumstances don't permit safe driving at a consistent speed.

## ACTIVATION/DEACTIVATION

### Activation

To activate the device, press and release the Adaptive Cruise Control (ACC) On/Off.

When the system is enabled and ready for operation, a graphic indicating the "readiness" of the system and a dedicated icon will appear on the display. The symbol is grey with system enabled and turns white when the system is activate (set speed).

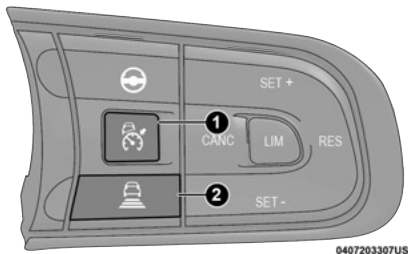

**Co-Driver with ACC**

- 1 — Adaptive Cruise Control (ACC) On/Off Button
- 2 — Distance Setting Button

### Deactivation

Press the ACC button to deactivate the system.

### WARNING!

It is dangerous to leave the device on when it is not used. There is a risk of inadvertently activating it and losing control of the car due to unexpected excessive speed.

## SETTING THE DESIRED SPEED

You can set the desired speed when the vehicle is stationary or in motion, within the range of 20 mph (30 km/h) up to 150 km/h (150 km.h).

### To Set

When your car reaches the speed you want, press and release either the button SET + or SET - to lock in the speed. The display will indicate the set speed.

Remove your foot from the accelerator pedal.

If you press the accelerator pedal, the car will accelerate faster than the set speed. During this time, you'll see a dedicated message on the display for a few seconds. The system won't control the distance between your vehicle and the one in front, and the speed will be determined solely by the position of the accelerator pedal.

The system will return to normal operation as soon as you release the accelerator pedal.

The system cannot be set in the following situations:

- When the brake pedal is applied.
- If the brakes are overheated.
- When the electric parking brake is engaged.

- When the transmission is in P (Park), R (Reverse), or N (Neutral).
- When the Electronic Stability Control (ESC) system (or ABS or other stability control systems) is actively intervening or has just completed an intervention.
- When the Autonomous Emergency Brake Control (AEB Control) system (if equipped) is automatically applying the brakes.
- If the Speed Limiter is active, you can deactivate it by pressing the ACC button on the steering wheel. Press the ACC button again to set the system to "ready" status.
- In case of a device malfunction.
- When the engine is off.
- On very steep slopes.
- If the radar sensor is obstructed, clean the sensor with a clean cloth. Do not use solvents or abrasive paste. In this scenario, the system may cancel or deactivate for a period depending on the conditions.

**NOTE:**

The system is not deactivated when speeds higher than those set are reached with the accelerator pedal pressed. In these conditions, the system may not work correctly, and it's advisable to deactivate it.

**Increasing/Decreasing Of Speed**

After having set the system, the stored speed can be increased or decreased by holding the SET + and SET - buttons pressed.

- **Press the SET + or SET - button once:** the set speed will increase or decrease by 1 mph (1 km/h). Each

subsequent press of the button will result in an increase or decrease of 1 mph (1 km/h).

- **Hold the SET + or SET - button pressed:** the set speed will increase or decrease in 5 mph steps (or 10 km/h) until the button is released.

The set speed increase or decrease is shown on the display.

**Warnings**

- By keeping the accelerator pedal depressed, the vehicle can continue to accelerate beyond the set speed. In this case, press the SET + or SET - button to set the speed to the current speed of the vehicle.
- When the SET - button is pressed to reduce the speed, the braking system intervenes automatically if the exhaust brake does not slow the car down sufficiently to reach the set speed.
- The system holds the set speed uphill and downhill; however a slight variation is entirely normal, particularly on steep gradients.
- The device is switched off while driving if the brakes overheat.

**Speed Variation With Road Sign (Intelligent Adaptive Cruise Control)**

The Intelligent Adaptive Cruise Control system can be used to set a speed limit equal to that indicated on the road sign detected by the Traffic Sign Recognition system → page 76.

When a new speed limit is recognized, the Traffic Sign Information system will suggest the new limit, which

will be shown with a message on the instrument panel display. The driver can accept the new limit by pressing the RES button to set the Adaptive Cruise Control speed to that suggested by the road sign.

The activation of the Intelligent Adaptive Cruise Control is indicated by the relative symbol on the display and the green circle around the speed limit sign.

**Coming To A Stop And Restarting**

The system can decelerate the vehicle to a standstill when the vehicle in front of it slows down and stops. The system will automatically restart the vehicle if the vehicle comes to a stop and the vehicle in front restarts within 2 seconds. If the vehicle in front restarts after 2 seconds, the RES button or the accelerator pedal must be pressed to reactivate the system and restart. If the system keeps the vehicle at a standstill for 2 minutes, the electric parking brake will activate and the system will be deactivated.

**NOTE:**

The electric parking brake will be activated and the system will be deactivated at speeds close to stopping, if the driver unbuckles the seat belt or opens the door.

**WARNING!**

The driver must ensure that there are no pedestrians, vehicles or other obstacles in front of the vehicle when the system is reactivated. Failure to comply with this precaution may cause serious accidents and fatal injuries.

## Recalling The Speed

Once the system has been cancelled by pressing the brake pedal or the CANC button but not deactivated by pressing the Adaptive Cruise Control (ACC) On/Off, simply press the RES button and take your foot off the accelerator pedal to recall a previously set speed.

The system will be set to the last stored speed.

Before returning to the previously set speed, bring the speed close to that value, then press the RES button and release it.

### WARNING!

The recall function must only be used if the road and traffic conditions so allow. Recalling an excessively high or low speed for the current traffic and road conditions could cause a sudden acceleration or a deceleration of the car. Failure to comply with these precautions may cause serious accidents and fatal injuries.

## TO VARY THE SPEED SETTING

### To Increase Or Decrease The Set Speed

After setting a speed, you can increase the set speed by pushing the SET (+) button, or decrease speed by pushing the SET (-) button.

#### U.S. Speed (mph)

- Pushing the SET (+), or SET (-) button once will result in a 1 mph speed adjustment. Each subsequent tap of the button results in an adjustment of 1 mph.

- If the button is continually pushed, the set speed will continue to adjust in 5 mph increments until the button is released. The new set speed is reflected in the instrument cluster display.

#### Metric Speed (km/h)

- Pushing the SET (+), or SET (-) button once will result in a 1 km/h speed adjustment. Each subsequent tap of the button results in an adjustment of 1 km/h.
- If the button is continually pushed, the set speed will continue to adjust in 10 km/h increments until the button is released. The new set speed is reflected in the instrument cluster display.

#### NOTE:

When you override and push the SET (+) button or SET (-) button, the new set speed will be the current speed of the vehicle.

#### When ACC Is Active

- When you use the SET (-) button to decelerate, if the engine's braking power does not slow the vehicle sufficiently to reach the set speed, the brake system will automatically slow the vehicle.
- The ACC system decelerates the vehicle to a full stop when following the vehicle in front. If your vehicle follows the vehicle in front to a standstill, after two seconds the driver will either have to push the RES (resume) button, or apply the accelerator pedal to reengage the ACC to the existing set speed.
- The ACC system maintains set speed when driving uphill and downhill. However, a slight speed change on moderate hills is normal. In addition, downshifting may occur while climbing uphill or

descending downhill. This is normal operation and necessary to maintain set speed. When driving uphill and downhill, the ACC system will cancel if the braking temperature exceeds normal range (overheated).

## TO VARY THE SPEED WITH INTELLIGENT ADAPTIVE CRUISE CONTROL

The Intelligent Adaptive Cruise Control system allows you to set a speed limit that matches the road sign detected by the Traffic Sign Recognition system  page 76. When a new speed limit is recognized, the TSR system will propose the new limit, and it will be displayed as a message on the instrument panel.

To accept the new limit, the driver can press the RES button to adjust the Adaptive Cruise Control speed to the speed suggested by the road sign.

The activation of the Intelligent Adaptive Cruise Control is indicated by the  indicator light on the display and a green circle around the speed limit sign.

## OPERATION AT A STOP

The system has the capability to slow down the car to a complete stop when the vehicle in front of it reduces speed and comes to a stop. It can automatically restart the car if it stops and the vehicle in front resumes within 2 seconds. If the vehicle ahead restarts after 2 seconds, you will need to press the RES button or the accelerator pedal to reactivate the system and restart.

If the target vehicle does not start moving within 2 seconds of your vehicle coming to a standstill, the ACC with Stop system will cancel and the brakes

will release. A cancel message will display on the instrument cluster display and produce a warning chime.

If the system keeps the car at a standstill for 2 minutes, the electric parking brake will engage, and the system will be deactivated.

#### NOTE:

The electric parking brake will be activated, and the system will be deactivated when the car is close to stopping speeds if the driver unbuckles the seat belt or opens the door.

#### WARNING!

When the ACC system is resumed, the driver must ensure that there are no pedestrians, vehicles or objects in the path of the vehicle. Failure to follow these warnings can result in a collision and death or serious personal injury.

## TO RESUME

If the system has been canceled by pressing the brake pedal or the CANC (cancel) button, but have not deactivated it by pressing the ACC button on the steering wheel, the system can be recalled to the previously set speed. To do this:

#### To Recall The Set Speed

- Press the RES button on the steering wheel.
- Remove foot from accelerator pedal.

The system will then be set to the last stored speed set before canceling it.

Resume can be used at any speed above 0 mph (0 km/h) when ACC is active.

It is advisable to approach the previously set speed gradually by bringing the current speed close to that value. Then, press the RES button and release it to engage the system at the desired speed.

#### WARNING!

The Resume function should only be used if traffic and road conditions permit. Resuming a set speed that is too high or too low for prevailing traffic and road conditions could cause the vehicle to accelerate or decelerate too sharply for safe operation. Failure to follow these warnings can result in a collision and death or serious personal injury.

## SETTING THE DISTANCE BETWEEN VEHICLES

The distance between your vehicle and the vehicle ahead may be set to 1 bar (short), 2 bars (medium), 3 bars (long), 4 bars (maximum).

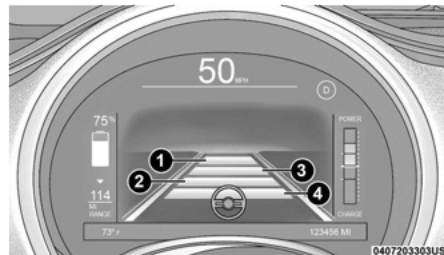

#### Distance Settings

- 1 — Longest Distance Setting (Four Bars)
- 2 — Medium Distance Setting (Two Bars)
- 3 — Long Distance Setting (Three Bars)
- 4 — Short Distance Setting (One Bar)

These distances are relative to the vehicle's speed. The time interval in relation to the vehicle ahead remains consistent, ranging from 1 second for the short-distance 1-bar setting to 2 seconds for the maximum-distance 4-bar setting. The selected distance is shown on the instrument cluster display.

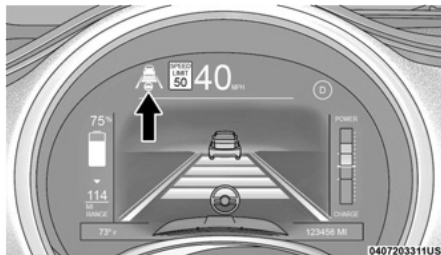

### ACC Distance Icon

The system is initially set to 4 bars (maximum) the first time it is used. After the driver adjusts the distance, the new setting will be retained even after the system is turned off and then reactivated.

### To Decrease The distance

Press and release the Distance Increase/Decrease button on the steering wheel to decrease the distance setting. Each time the button is pressed, the distance setting decreases by one bar, making it shorter.

When the shortest distance setting is reached, pressing the button again will set the longest distance. The system will maintain the set speed if there are no vehicles ahead.

If a vehicle in the same lane, traveling at a slower speed, is detected on the instrument panel, an icon (if equipped) will appear on the display. The system will automatically adjust your car's speed to maintain the set distance, regardless of the set speed.

The car will maintain the set distance until any of the following occur:

- The vehicle ahead accelerates to a speed higher than the set speed.
- The vehicle ahead changes lanes or leaves the detection field of the Adaptive Cruise Control device sensor.
- The distance setting is altered.
- The Adaptive Cruise Control device is deactivated or canceled.

### CAUTION!

- The maximum braking applied by the device is limited. The driver may apply the brakes in all cases if needed.
- If the device predicts that the level of braking is not sufficient to maintain the set distance, the word "BRAKE!" or a dedicated message on the instrument panel display warns the driver that the vehicle ahead is too close. An acoustic signal is also emitted. In this case, it is advisable to brake immediately as necessary to hold a safe distance from the vehicle ahead.
- The driver is responsible for ensuring that there are no pedestrians, other vehicles or objectives along the direction of the vehicle. Failure to comply with these precautions may cause serious accidents and injuries.
- The driver is fully responsible for holding a safe distance from the vehicle ahead respecting the highway code in force in the respective country.

## OVERTAKING AID FUNCTION

The Adaptive Cruise Control system, when traffic conditions allow, permits additional acceleration for overtaking by simply activating the direction indicator. This extra acceleration is provided as long as it's ensured that there is sufficient distance to overtake the other vehicle.

Once the acceleration begins, the driver should ensure that it's safe to do so, considering the traffic and vehicles approaching from behind. The driver can then execute the lane change maneuver to overtake. After the overtaking is completed and the path is clear of vehicles, the Adaptive Cruise Control system will resume control of the chosen speed or reduce it to maintain the desired distance from the vehicle ahead.

### NOTE:

The overtaking aid function is available on the side where overtaking is legally permitted according to the traffic regulations (on the left in countries with right-side traffic and on the right in countries with left-side traffic).

### WARNING!

The device detects the direction of traffic automatically when the car passes from left-hand traffic to right-hand traffic. In this case, the overtaking assist function is only active when the reference vehicle is overtaken on the right. The additional acceleration is activated when the driver uses the right direction indicator. In this condition, the device no longer provides the overtaking assist function on the left-hand side until it determines that the car has returned to left-hand traffic conditions.



## SPEED REDUCTIONS ON BENDS

The Adaptive Cruise Control system has the capability to make slight speed reductions during bends to enhance vehicle stability and passenger comfort. This feature can be especially helpful in roundabouts or on gently curved roads where the curvature gradually increases. However, it cannot compensate for abrupt steering maneuvers or moderate-to-high lateral accelerations in general.

In scenarios where the traffic situation demands it, it is the driver's responsibility to apply the brakes, as needed, to further decrease the vehicle's speed, ensuring stability on tight bends or steep descents.

## DEACTIVATION

The device is deactivated, and the set speed is canceled if:

- The Adaptive Cruise Control (ACC) On/Off is pressed.
- The Active Speed Limiter button is pressed.
- The ignition device switch is in the OFF position.

The system is canceled, and the set speed and distance are stored in the following cases:

- When the CANC button is pressed.
- When the conditions indicated in the paragraph "Setting the desired speed" occur.

If these conditions occur while the system is decelerating concerning a vehicle ahead, the system may continue the deceleration, if necessary, even after it has been canceled or deactivated, as long as it

remains above the minimum speed that can be set within the system.

## SYSTEM LIMITED OPERATION WARNING

If the dedicated message is shown on the display, a condition limiting the system operation may have occurred. The possible reasons of this limitation are something blocking the camera view or a fault.

In the case of camera glare (e.g., due to low sun in front of the windscreen or in foggy or heavy rain conditions), it's advisable to wait until the lighting and glare conditions improve, allowing the system to resume full operation.

If an obstruction is signalled, clean the camera area of the windshield and verify if the message has disappeared.

Once the conditions that limited the system's functionality have ended, it will return to its regular and full operation. If the issue persists, it's recommended to contact an authorized dealer for assistance.

## PRECAUTIONS WHILE DRIVING WITH ACC

In certain driving situations, ACC may have detection issues. In these cases, ACC may brake late or unexpectedly. The driver needs to stay alert and may need to intervene. The following are examples of these types of situations:

### Towing A Trailer

Towing a trailer is not recommended when using ACC.

## Offset Driving

ACC may not detect a vehicle in the same lane that is offset from your direct line of travel, or a vehicle merging in from a side lane. There may not be sufficient distance to the vehicle ahead. The offset vehicle may move in and out of the line of travel, which can cause your vehicle to brake or accelerate unexpectedly.

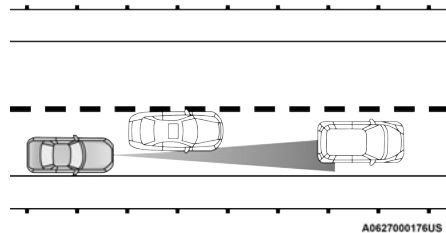

Offset Driving Condition Example

## Turns And Bends

When driving on a curve with ACC engaged, the system may increase or decrease the vehicle speed for stability, with no vehicle ahead detected. Once the vehicle is out of the curve, the system will resume your original set speed. This is a part of normal ACC system functionality.

### NOTE:

On tight turns ACC performance may be limited.

## Using ACC On Hills

ACC performance may be limited when driving on hills. ACC may not detect a vehicle in your lane depending on the speed, vehicle load, traffic conditions, and the steepness of the hill.

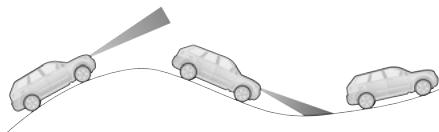

A0627000178US

### ACC Hill Example

## Lane Changing

ACC may not detect a vehicle until it is completely in the lane in which you are traveling. In the following lane changing example, ACC has not yet detected the vehicle changing lanes and it may not detect the vehicle until it's too late for the ACC system to take action. ACC may not detect a vehicle until it is completely in the lane. There may not be sufficient distance to the lane-changing vehicle. Always be attentive and ready to apply the brakes if necessary.

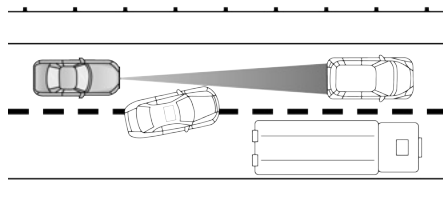

A0627000178US

### Lane Changing Example

## Narrow Vehicles

Some narrow vehicles traveling near the outer edges of the lane or edging into the lane are not detected until they have moved fully into the lane. There may not be sufficient distance to the vehicle ahead.

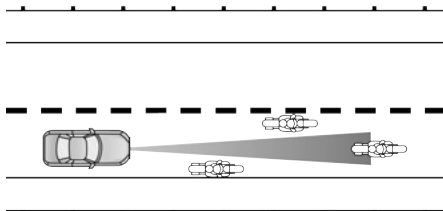

A0627000179US

### Narrow Vehicle Example

## Stationary Objects And Vehicles

ACC does not react to stationary objects or vehicles. For example, ACC will not react in situations where the vehicle you are following exits your lane and the vehicle ahead is stopped in your lane. It will consider this stopped vehicle a stationary object as it did not previously detect movement from it. Always be attentive and ready to apply the brakes if necessary.

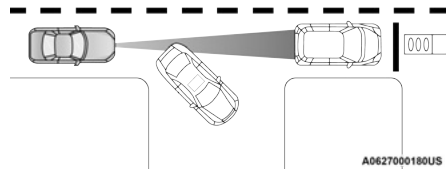

A0627000180US

### Stationary Object And Stationary Vehicle Example

## Objects and Vehicles Moving In Opposite Or Perpendicular Direction

The system cannot detect objects or vehicles traveling in the opposite or perpendicular direction, and therefore will not activate.

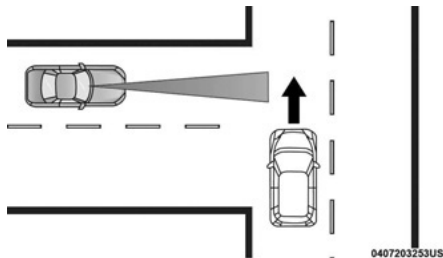

Objects Moving in Perpendicular Direction Example

## CO-DRIVER SYSTEM WITH STOP&GO – TRAFFIC JAM ASSIST— IF EQUIPPED

The system combines Active Cruise Control (ACC) features and lane centering logic to manage the car's trajectory, keeping it as close to the center of the lane as possible while also controlling speed.

This is a driving assistance system that can be engaged on all types of roads. It utilizes information from both the front camera and radar to assist in maintaining the car's position in the center of the lane while maintaining a consistent speed.

In cases where the lane marking lines are missing or not properly detected, the Co-Driver system may also rely on information from nearby vehicles, including those in front and around the car. This situation can arise in heavy traffic or when the car ahead and/or objects in the car's vicinity obstruct the lane markings. In such instances, the system can use the flow of traffic

to determine the optimal driving path. Alternatively, the system can employ a "lock-on" strategy, automatically tracking the vehicle in front.

### OPERATION

The system functions only if the driver maintains contact with the steering wheel. If the system detects that the driver's hands have been removed from the steering wheel, it will provide alerts to prompt the driver to place their hands back on the steering wheel.

### NOTE:

The Co-Driver system may require a few seconds to activate once all necessary conditions are met. During this brief activation period, a grey indicator will be displayed on the instrument panel, and the system will automatically activate once all the conditions are met, without any intervention from the driver.

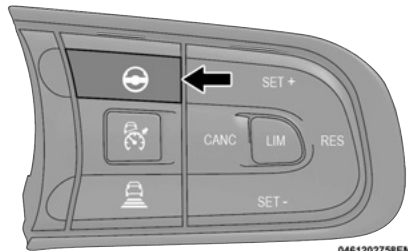

Co-Driver System On/Off Button

The following conditions must be met before the Co-Driver system turns on:

- The Co-Driver system must be activated by pressing the Co-Driver button on the steering wheel.
- The Adaptive Cruise Control device (ACC) must be activated.
- The vehicle's speed must fall within the range of 0 mph to 90 mph (0 km/h to 150 km/h).
- There should be no anomalies related to the camera or radar.
- The road lane width must be between 8.5 ft and 13.5 ft (2.7 meters and 4.2 meters).
- The direction indicators must not be activated
- There should be no anomalies related to the system itself.

### ACTIVATION AND DEACTIVATION

To activate the system, press the  button on the steering wheel.

To deactivate the system press the button again.

### Suspension conditions

System operation are temporarily paused under the following scenarios:

- When the ACC system gets deactivated or inhibited  page 79.
- Tight bends in the road.
- If the lines on the road are not detected accurately.
- When one of the two lines on the road are is damaged or broken.

- When the sun is low, causing glare on the windshield camera.
- If the driver activates the left or right turn signal.
- When the driver intentionally switches lanes without using the corresponding turn signal.
- In the event of system irregularities.
- When the vehicle speed exceeds the maximum limit.
- If lateral acceleration becomes too high.

#### Automatic deactivation

The Co-Driver system will automatically deactivate if you take your hands off the steering wheel for 45 seconds.

When the Co-Driver is paused the associated graphics in the designated area will turn grey.

When the steering wheel detects hands are on, the Co-Driver will be reactivated without any additional action needed from the driver.

#### WARNING!

It is dangerous to leave the device on when it is not used. There is a risk of inadvertently activating it and losing control of the car due to unexpected excessive speed.

### INDICATIONS ON THE DISPLAY

The system status can always be viewed through a dedicated area on the instrument panel display.

The system status is indicated by the color of the  symbol.

If the driver's hands are not on the steering wheel, a series of warnings will appear on the instrument panel display to alert the driver that he needs to reposition his hands on the steering wheel. Acoustic signals will also be emitted.

After a certain period of time, the Co-Driver system will be disabled if the driver has not repositioned their hands on the steering wheel.

When the system does not detect hands on the steering wheel for a few seconds, it will warn the driver by displaying a dedicated screen in the center of the instrument cluster display.

### SYSTEM STATUS

**System active:** A properly functioning system is verified by the display on the instrument panel. If hands are taken off the steering wheel, the system won't shut down immediately, only after a brief period: A series of dedicated screens will subsequently appear in succession on the instrument panel to remind the driver to place their hands back on the steering wheel.



System Active



System Active — Yellow

**Hands removed from the steering wheel for a short time:** As soon as you take your hands off the steering wheel, the system will provide this warning on the instrument panel display. The system will remain active. If the driver doesn't reposition their hands on the steering wheel within a few seconds, the following message will appear on the instrument cluster display.



### System Active — Red

#### Hands removed from the steering wheel for a long time:

If you fail to place your hands on the steering wheel, a screen will be displayed on the instrument cluster as well as an acoustic warning.



### System Deactivated

When hands are removed from the steering wheel, a countdown will begin, resulting in the activation of visual and audible alerts. Additionally, the system may

initiate a minimum risk maneuver to ensure the car's safety if no hands are detected.

The Adaptive Cruise Control system will apply slight braking 23 seconds after hands have been removed from the steering wheel to warn and encourage the driver to regain control of the vehicle. If control is not regained after an additional 3 seconds, the system will apply slight braking again. Subsequently, if hands are still not placed back on the steering wheel, the system will automatically apply the brakes to bring the vehicle to a complete stop.

When the vehicle comes to a stop, the system will unlock the doors (if they were previously locked) and switches the hazard lights on.

If the driver regains control of the vehicle during the minimum risk maneuver by placing hands on the steering wheel or pressing the accelerator pedal, the system will resume normal operation, and the minimum risk maneuver will be canceled.

#### NOTE:

When the Co-Driver system is active, LaneSense (if equipped) is temporarily paused. If the Co-Driver system is not active, LaneSense, if previously activated, remains available. For additional details on the LaneSense system, see page 106.

## SYSTEM OPERATION/LIMITATIONS

The Co-Driver system may experience limited or reduced functionality under certain conditions. The main ones include:

- Unclear or poor visibility of lane marking lines (e.g., heavy rain, snow, fog, etc.).

- Damage, obstruction, or coverage of either the camera or radar (e.g., by mud, ice, snow, etc.).
- Driving in hilly terrain or on roads with narrow turns.
- Proximity to highway toll-gates.
- Wide motorway entrance or exit (more than 20 ft (6 meters)).
- Exposure of the camera to intense or dazzling light (e.g., reflection or direct sunlight).

## FRONT/REAR PARK ASSIST — IF EQUIPPED

The Park Assist system provides visual and audible indications of the distance between the rear and/or front fascia/bumper and a detected obstacle when backing up or moving forward (e.g. during a parking maneuver).

For limitations of this system and recommendations, see page 104.

Park Assist will retain the last system state (enabled or disabled) from the last ignition cycle when the ignition is changed to the ON/RUN position.

Park Assist is active when the gear selector is shifted to REVERSE or to a forward gear and an obstacle is detected (if equipped with front sensors), as long as the system is on. When the gear selector shifted to NEUTRAL (or PARK in case of automatic gearbox), the system becomes inactive. When the vehicle is moving forward, the system will remain active until the vehicle speed remains below approximately 8 mph (13 km/h). Reducing the speed approximately below

7 mph (11 km/h), the system will come back active. When the vehicle is moving in REVERSE, the system will remain active as long as the speed remains below the maximum operating speed of 7 mph (11 km/h). When the maximum speed limit is exceeded, the system is disabled and the Park Assist switch LED will illuminate. The system will become active again if the vehicle speed reduces below approximately 6 mph (9 km/h).

## PARK ASSIST SENSORS

The three or five Park Assist sensors, located in the rear fascia/bumper, monitor the area behind the vehicle that is within the sensors' field of view. The sensors can detect obstacles from approximately 12 inches (30 cm) up to 59 inches (150 cm) from the rear fascia/bumper in the horizontal direction, depending on the location, type and orientation of the obstacle.

The four Park Assist sensors, located in the front fascia/bumper (if equipped), monitor the area in front

of the vehicle that is within the sensors' field of view. The sensors can detect obstacles from approximately 12 inches (30 cm) up to 35 inches (90 cm) from the front fascia/bumper in the horizontal direction, depending on the location, type and orientation of the obstacle.

## PARK ASSIST WARNING DISPLAY

The Park Assist Warning screen will only be displayed if "Sound and Display" is selected from the Uconnect system  page 113.

The Park Assist Warning screen is located within the instrument cluster display. It provides visual warnings to indicate the distance between the rear fascia/bumper and/or front fascia/bumper and the detected obstacle  page 57.

## PARK ASSIST DISPLAY

The Park Assist warning screen will be displayed when the activation conditions described before are met

The system will indicate a detected obstacle by showing a single arc in the left and/or right front or rear regions based on the object's distance and location relative to the vehicle.

If an object is detected in the left and/or right front or rear region, the display will show a single arc in the left and/or right front or rear region and the system will produce a tone. As the vehicle moves closer to the object, the display will show the single arc moving closer to the vehicle and the tone will change from a single 1/2 second tone to slow, to fast, to continuous.

**Solid arcs will be shown only when the obstacles are out of driving tube. In the other case, arcs will be flashing.**

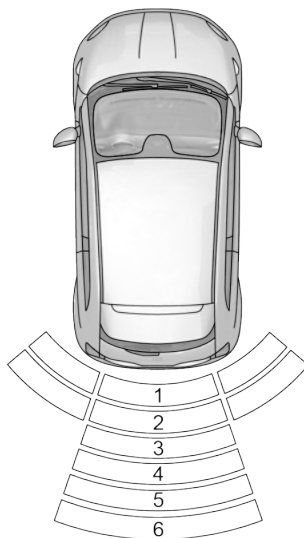

**Rear ParkSense Arcs**

- 1 – Continuous Tone/Flashing Arc
- 2 – Fast Tone/Flashing Arc
- 3 – Fast Tone/Flashing Arc
- 4 – Slow Tone/Flashing Arc
- 5 – Slow Tone/Flashing Arc
- 6 – Slow Tone/Flashing Arc

0430203206EM

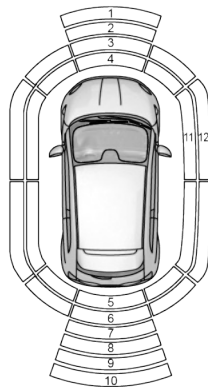

0430202988EM

### Front/Rear/Side ParkSense Arcs

- 1 – Slow Tone/Flashing Arc
- 2 – Fast Tone/Flashing Arc
- 3 – Fast Tone/Flashing Arc
- 4 – Continuous Tone/Flashing Arc
- 5 – Continuous Tone/Flashing Arc
- 6 – Fast Tone/Flashing Arc

- 7 – Fast Tone/Flashing Arc
- 8 – Slow Tone/Flashing Arc
- 9 – Slow Tone/Flashing Arc
- 10 – Slow Tone/Flashing Arc
- 11 – Continuous Tone/Flashing Arc
- 12 – Fast Tone/Flashing Arc

The vehicle is close to the obstacle when the warning display shows one flashing arc and sounds a continuous tone. The following charts show the warning alert operation when the system is detecting an obstacle:

<b>WARNING ALERTS FOR REAR</b>							
Rear Distance (inches/cm)	Greater than 59 inches (150 cm)	59-52 inches (150-130 cm)	52-41 inches (130-105 cm)	41-34 inches (105-85 cm)	34-24 inches (85-60 cm)	24-12 inches (60-30 cm)	Less than 12 inches (30 cm)
Arcs – Left	None	None	None	None	None	6th Flashing	5th Flashing
Arcs – Center	None	10th Flashing	9th Flashing	8th Flashing	7th Flashing	6th Flashing	5th Flashing



WARNING ALERTS FOR REAR								
Arcs — Right	None	None	None	None	None	6th Flashing	5th Flashing	
Audible Alert Chime	None	Audible chime increases as the object gets closer to the vehicle					Continuous	
Radio Volume Reduced	No	Yes						

WARNING ALERTS FOR FRONT					
Front Distance (inches/cm)	Greater than 35 inches (90 cm)	35-30 inches (90-75 cm)	30-24 inches (75-60 cm)	24-12 inches (60-30 cm)	Less than 12 inches (30 cm)
Arcs — Left	None	None	None	3rd Flashing	4th Flashing
Arcs — Center	None	1st Flashing	2nd Flashing	3rd Flashing	4th Flashing
Arcs — Right	None	None	None	3rd Flashing	4th Flashing
Audible Alert Chime	None	Audible chime increases as the object gets close to the vehicle			Continuous
Radio Volume Reduced	No	Yes			

**NOTE:**

Park Assist will reduce the volume of the radio, if on, when the system is sounding an audible tone.

**Front Park Assist Audible Alerts**

Park Assist will turn off the Front Park Assist audible alert (chime) after approximately three seconds when an obstacle has been detected, and the vehicle is stationary. If the obstacle has been detected within less than 12 inches (30 cm), then the Park Assist will not turn off the Front Park Assist audible alert.

**Adjustable Chime Volume Settings**

Front and Rear chime volume settings can be selected from the Customer-Programmable Features section of the Uconnect system → page 113.

If the Uconnect system is equipped, chime volume settings will not be accessible from the instrument cluster display.

The chime volume settings include low, medium, and high.

Park Assist will retain its last known configuration state through ignition cycles.

**ENABLING AND DISABLING PARK ASSIST**

Park Assist can be enabled and disabled with the Park Assist switch, located on the left side of the dashboard.

When the Park Assist switch is pushed to disable the system, the instrument cluster display will show the "Park Assist Disabled" message for approximately five seconds → page 57.

The Park Assist switch LED, above speed threshold will always be on and below speed threshold only if the system is disabled or requires service. The Park Assist switch LED will be off when the system is enabled and the below speed threshold. If the Park Assist switch

is pushed, and the system requires service, the Park Assist switch LED will blink momentarily, and then the LED will be on.

**NOTE:**

The rear sensors are automatically deactivated if a trailer's electric plug is inserted in the vehicle's trailer electrical socket. The front sensors stay active and can provide acoustic and visual warnings. The rear sensors are automatically reactivated when the trailer's cable plug is removed.

**SERVICE THE PARK ASSIST SYSTEM**

During vehicle start up, when the Park Assist System has detected a faulted condition, the instrument cluster display will actuate a single chime, once per ignition cycle, and it will show the "PARK ASSIST UNAVAILABLE WIPE REAR SENSORS", "PARK ASSIST UNAVAILABLE WIPE FRONT SENSORS", or the "PARK

ASSIST UNAVAILABLE SERVICE REQUIRED" message for five seconds.

If "PARK ASSIST UNAVAILABLE WIPE REAR SENSORS" or "PARK ASSIST UNAVAILABLE WIPE FRONT SENSORS" appears in the instrument cluster display make sure the outer surface and the underside of the rear fascia/bumper and/or front fascia/bumper is clean and clear of snow, ice, mud, dirt or other obstruction and then cycle the ignition. If the message continues to appear see an authorized dealer.

If the "PARK ASSIST UNAVAILABLE SERVICE REQUIRED" message appears in the instrument cluster display, see an authorized dealer.

## CLEANING THE PARK ASSIST SYSTEM

Clean the Park Assist sensors with water, car wash soap and a soft cloth. Do not use rough or hard cloths. Do not scratch or poke the sensors. Otherwise, you could damage the sensors.

## PARK ASSIST SYSTEM USAGE PRECAUTIONS

### NOTE:

- Ensure that the outer surface and the underside of the front and rear fascia/bumper are clean and clear of snow, ice, mud, dirt or other obstruction to keep the Park Assist system operating properly.
- Jackhammers, large trucks, and other vibrations could affect the performance of Rear Park Assist.
- Clean the Park Assist sensors regularly, taking care not to scratch or damage them. The sensors must not be covered with ice, snow, slush, mud, dirt or debris. Failure to do so can result in the system not

working properly. The Park Assist system might not detect an obstacle behind the fascia/bumper, or it could provide a false indication that an obstacle is behind the fascia/bumper.

- Objects such as bicycle carriers, etc., must not be placed within 12 inches (30 cm) from the rear fascia/bumper while driving the vehicle. Failure to do so can result in the system misinterpreting a close object as a sensor problem, causing a failure indication to be displayed in the instrument cluster.

### WARNING!

- Drivers must be careful when backing up even when using Park Assist. Always check carefully behind your vehicle, look behind you, and be sure to check for pedestrians, animals, other vehicles, obstructions, and blind spots before backing up. You are responsible for safety and must continue to pay attention to your surroundings. Failure to do so can result in serious injury or death.
- Before using Park Assist, it is strongly recommended that the ball mount and hitch ball assembly be disconnected from the vehicle when the vehicle is not used for towing. Failure to do so can result in injury or damage to vehicles or obstacles because the hitch ball will be much closer to the obstacle than the rear fascia when the vehicle sounds the continuous tone. Also, the sensors could detect the ball mount and hitch ball assembly, depending on its size and shape, giving a false indication that an obstacle is behind the vehicle.

### CAUTION!

- Park Assist is only a parking aid and it is unable to recognize every obstacle, including small obstacles. Parking curbs might be temporarily detected or not detected at all. Obstacles located above or below the sensors will not be detected when they are in close proximity.
- The vehicle must be driven slowly when using Park Assist in order to be able to stop in time when an obstacle is detected. It is recommended that the driver looks over his/her shoulder when using Park Assist.

If it is necessary to keep the trailer hitch and hitch ball assembly mounted for a long period, it is possible to filter out the trailer hitch and hitch ball assembly presence within the sensor's field of view. The filtering operation must be performed only by an authorized dealer.

## SIDE DISTANCE WARNING SYSTEM — IF EQUIPPED

The Side Distance Warning system detects the presence of side obstacles near the vehicle using the parking sensors located in the front and rear fascia/bumpers.

### Side Distance Warning Display

The Side Distance Warning screen will only be displayed if this feature is enabled within Uconnect Settings  page 113.

The system warns the driver with an acoustic signal and when selected, with visual indications on the instrument panel display → page 57.

The acoustic indications come activate only when the obstacle is detected within the trajectory of the vehicle and therefore there would be a risk of collision.

Visual indications are always provided to the driver, even when the obstacle is not in the trajectory of the vehicle.

**NOTE:**

ParkSense will reduce the volume of the radio if on when the system is sounding an audible tone.

### Activation/Deactivation

The system can operate only after driving a short distance and if the vehicle speed is between 0 and 11 mph (0 and 18 km/h). The system can be activated/deactivated via the "Settings" menu of the Uconnect system. If the ParkSense System is deactivated via the ParkSense switch, then the side distance warning system will automatically be deactivated.

**NOTE:**

The vehicle needs to be driven approximately one car length in order for the Side Distance Warning system to activate.

### Operation With A Trailer

The system is automatically deactivated when the trailer's electric plug is inserted in the vehicle's tow hook socket. The rear sensors are automatically reactivated when the trailer's cable plug is removed.

## ParkSense Usage Precautions

Some conditions may influence the performance of the Side Distance Warning system:

**NOTE:**

- Ensure that the front and rear fascias/bumpers are free of snow, ice, mud, dirt and debris to keep the ParkSense system operating properly.
- Construction equipment, large trucks, and other vibrations could affect the performance of ParkSense.
- When you turn ParkSense off, the message in the instrument cluster display will read "PARKSENSE OFF." Furthermore, once you turn ParkSense off, it remains off until you turn it on again, even if you cycle the ignition key.
- ParkSense, when on, will reduce the volume of the radio when it is sounding a tone.
- Clean the ParkSense sensors regularly, taking care not to scratch or damage them. The sensors must not be covered with ice, snow, slush, mud, dirt or debris. Failure to do so can result in the system not working properly. The ParkSense system might not detect an obstacle behind or in front of the fascia/bumper, or it could provide a false indication that an obstacle is behind or in front of the fascia/bumper.
- The presence of a tow hook without a trailer may interfere with the correct operation of the parking sensors. Before using the ParkSense system, it is recommended to remove the removable tow hook ball assembly and any attachments from the vehicle when it is not used for towing operations. If you leave the tow hook fitted when not towing a trailer, the

tow hook could be detected as an obstacle by the sensors. Contact your authorized dealer to update the ParkSense system operations.

**WARNING!**

- Drivers must be careful when backing up even when using ParkSense. Always check carefully behind your vehicle, look behind you, and be sure to check for pedestrians, animals, other vehicles, obstructions, and blind spots before backing up. You are responsible for safety and must continue to pay attention to your surroundings. Failure to do so can result in serious injury or death.
- Before using ParkSense, it is strongly recommended that the ball mount and hitch ball assembly be disconnected from the vehicle when the vehicle is not used for towing. Failure to do so can result in injury or damage to vehicles or obstacles because the hitch ball will be much closer to the obstacle than the rear fascia/bumper when the vehicle sounds the continuous tone. Also, the sensors could detect the ball mount and hitch ball assembly, depending on its size and shape, giving a false indication that an obstacle is behind the vehicle.

**CAUTION!**

- ParkSense is only a parking aid and it is unable to recognize every obstacle, including small obstacles. Parking curbs might be temporarily detected or not detected at all. Obstacles located

*(Continued)*

**CAUTION**

above or below the sensors will not be detected when they are in close proximity.

- The vehicle must be driven slowly when using ParkSense in order to be able to stop in time when an obstacle is detected. It is recommended that the driver looks over his/her shoulder when using ParkSense.

**LANESENSE — IF EQUIPPED****LANESENSE OPERATION**

The LaneSense system utilizes a windshield-mounted camera to identify lane boundaries and determine the car's position within those boundaries, ensuring it stays within the lane.

When one of the lane markings are detected and the driver drifts out of the lane (no turn signal applied), the LaneSense system provides a haptic warning in the form of torque applied to the steering wheel to prompt the driver to remain within the lane boundaries. If the driver continues to drift out of the lane, the LaneSense system provides a visual warning through the instrument cluster display to prompt the driver to remain within the lane boundaries.

**NOTE:**

The torque applied to the steering wheel by the system is sufficient for the driver to notice it, but always limited, so that they can easily override it. The driver may manually override the haptic warning by applying force to the steering wheel at any time.

If the vehicle continues to drift beyond the lane boundary without any driver intervention, a warning light will illuminate on the instrument cluster display, urging the driver to steer the car back into the lane's boundaries.

**NOTE:**

The LaneSense system is operational at speeds above 37 mph (60 km/h) and below 93 mph (150 km/h). The LaneSense system uses a forward facing camera to detect lane markings and measure vehicle position within the lane boundaries.

**TURNING LANESENSE ON OR OFF**

The LaneSense button is located on the end of the turn signal stalk, located on the left side of the steering column.

To turn the LaneSense system on, push the LaneSense button once. A "Lane Sense On" message is shown in the instrument cluster display.

To turn the LaneSense system off, push the LaneSense button twice within 5 seconds.

On some models, when LaneSense is disabled, a message along with a warning light will be displayed on the instrument cluster display.

**NOTE:**

The system will retain the last state (on or off) that was active during engine shut down. The next time the engine is started, the system will either be active or stay off.

**CHANGING LANESENSE STATUS**

The LaneSense system has settings to adjust the intensity of the torque warning and the warning zone sensitivity (early/medium/late) that you can configure through the Uconnect system screen page 113.

**NOTE:**

Once active, the system will operate when the following conditions are met:

- The driver maintains at least one hand on the steering wheel at all times.
- The vehicle's speed falls within the range of 37 mph to 93 mph (60 km/h to 150 km/h).
- The lane is marked on at least one side.
- Visibility conditions are appropriate.
- The road is straight or with wide radius bends.
- The turn signal is not engaged in the same direction as the lane departure.

**NOTE:**

The system will not apply torque to the steering wheel whenever a safety system engages. (Anti-Lock Brakes, Traction Control System, Electronic Stability Control, Full Brake Control system, etc.).

**LANESENSE WARNING MESSAGE**

The LaneSense system alerts the driver when the car drifts out of its lane by displaying symbols and messages on the instrument panel display.

While the system is in operation and hasn't detected the lane boundaries, the lane lines appear in grey, and a specific icon is displayed in the dedicated upper section of the display.

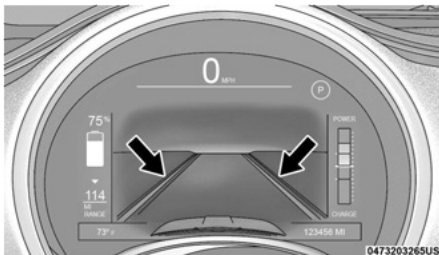

### System On (Gray Lines/White Telltale)

#### Single Lane Departure — Only Left Lane Detected

- When the system is active and has detected only the left lane, the car icon is displayed in the dedicated area of the screen. In this state, the system is prepared to deliver visual warnings in case of unintentional lane departure to the left (with no direction indicator activation).
- As the system detects the car's proximity to the lane line, the left lane line on the display turns yellow, and the car icon displayed also turns yellow. If the system detects that the car is approaching the lane line and is about to cross it, the left lane line (in yellow) flashes, and the car icon displayed also turns yellow.

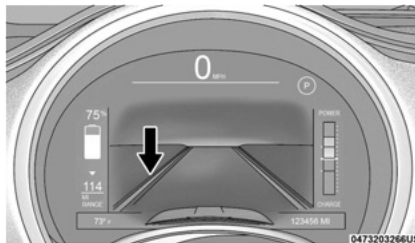

### Lane Approached (Flashing Yellow Line/Flashing Yellow Telltale)

#### NOTE:

- The LaneSense system operates with similar behavior for a right lane departure when only the right lane marking has been detected.
- The system will only provide visual warnings and will not make steering corrections to realign the car's path.

#### Lane Departure — Both Lanes Detected

- When the LaneSense system is on, the lane lines turn from gray to white to indicate that both of the lane markings have been detected. The LaneSense telltale is solid green when both lane markings have been detected and the system is ready to provide visual warnings in the instrument cluster display and a torque warning in the steering wheel if a lane departure occurs.

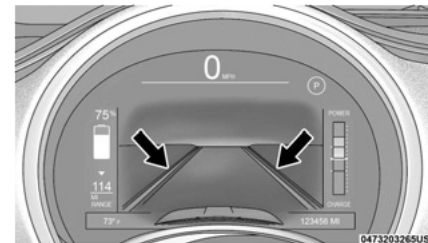

### Lanes Sensed (White Lines/Green Telltale)

#### NOTE:

- Based on the various conditions it detects, the system can grab the driver's attention by modifying the characteristics of the lane identification lines on the display. Specifically, it can change their color (from white to yellow and vice versa) and make them flash. Additionally, the system adjusts the color of the car icon displayed on the screen as needed.
- When the LaneSense system senses a lane drift situation, the left lane line turns solid yellow. The LaneSense telltale changes from solid green to solid yellow. At this time torque is applied to the steering wheel in the opposite direction of the lane boundary.
- For example: If approaching the left side of the lane the steering wheel will turn to the right.

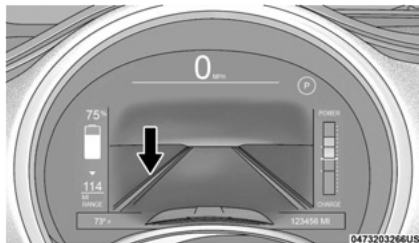

### Lane Sensed (Solid Yellow Line/Solid Yellow Telltale)

- When the LaneSense system senses the lane has been approached and is in a lane departure situation, the left lane line flashes yellow (on/off). The LaneSense telltale changes from solid yellow to flashing yellow. At this time torque is applied to the steering wheel in the opposite direction of the lane boundary.

For example: If approaching the left side of the lane the steering wheel will turn to the right.

### System Limited Operation Warning

If a dedicated message appears on the display, it could indicate a condition that limits the system's operation. Possible reasons for this limitation include an obstruction blocking the camera's view or a system fault.

If an obstruction is detected, clean the area of the windshield near the interior rearview mirror and verify if the message disappears. Even if the car can still be

driven under normal conditions, the system may not be fully available.

Once the conditions restricting the system's functions are resolved, it will return to its normal and complete operation. However, if the fault continues, it's advisable to get in touch with an authorized dealer for further assistance.

### No Hands On Steering Wheel Detection

When the system detects the absence of hands on the steering wheel during active system intervention, it will initiate a series of escalating visual and acoustic warnings. This process will span 15 seconds, with the goal of prompting the driver to place their hands back on the steering wheel.

If the driver does not return their hands to the wheel within this 15-second window, the system will disengage and issue an additional warning lasting 5 seconds.

### System Fault

If the system deactivates and displays a message on the instrument cluster display, it signifies a fault within the system. It is still possible to drive the car, but it is strongly recommended that you contact an authorized dealer.

## PARKVIEW REAR BACK UP CAMERA

The ParkView Rear Back Up Camera allows you to see an on-screen image of the rear surroundings of your vehicle when the gear selector is put into REVERSE. The image will be displayed on the touchscreen display along with a note to "Check Entire Surroundings" across the top of the screen. After five seconds this

note will disappear. The ParkView camera is located on the rear of the vehicle on the boot tailgate.

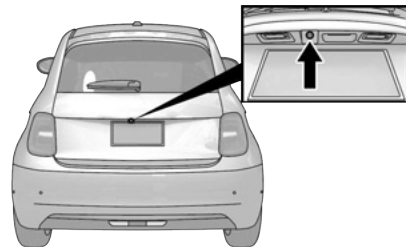

### Back Up Camera Location

When the vehicle is shifted out of REVERSE with camera delay turned off, the rear camera mode is exited and the navigation or audio screen appears again.

When the vehicle is shifted out of REVERSE with camera delay turned on, the camera image will continue to be displayed for up to 10 seconds unless the vehicle speed exceeds 8 mph (13 km/h), the vehicle is shifted into PARK, or the ignition is placed in the OFF position.

A touchscreen button to disable the camera is available when the vehicle is not in REVERSE. Display of the camera image after shifting out of REVERSE can be disabled via Uconnect Settings.

When enabled, active guidelines are overlaid on the image to illustrate the width of the vehicle and its projected back up path based on the steering wheel position.

Different colored zones indicate the distance to the rear of the vehicle.

The following table shows the approximate distances for each zone:

Zone	Distance To The Rear Of The Vehicle
Red	0 - 1 ft (0 - 30 cm)
Yellow	1 ft - 3 ft (30 cm - 1 m)
Green	3 ft or greater (1 m or greater)

#### NOTE:

If snow, ice, mud, or any foreign substance builds up on the camera lens, clean the lens, rinse with water, and dry with a soft cloth. Do not cover the lens.

#### WARNING!

Drivers must be careful when backing up even when using the ParkView Rear Back Up Camera. Always check carefully behind your vehicle, and be sure to check for pedestrians, animals, other vehicles, obstructions, or blind spots before backing up. You are responsible for the safety of your surroundings and must continue to pay attention while backing up. Failure to do so can result in serious injury or death.

#### CAUTION!

- To avoid vehicle damage, ParkView should only be used as a parking aid. The ParkView camera is unable to view every obstacle or object in your drive path.

*(Continued)*

#### CAUTION!

- To avoid vehicle damage, the vehicle must be driven slowly when using ParkView to be able to stop in time when an obstacle is seen. It is recommended that the driver look frequently over his/her shoulder when using ParkView.

## VEHICLE LOADING

### CERTIFICATION LABEL

As required by National Highway Traffic Safety Administration regulations, your vehicle has a certification label affixed to the driver's side door or B-pillar.

This label contains the month and year of manufacture, Gross Vehicle Weight Rating (GVWR), front and rear Gross Axle Weight Rating (GAWR), and Vehicle Identification Number (VIN). A Month-Day-Hour (MDH) number is included on this label and indicates the Month, Day and Hour of manufacture. The bar code that appears on the bottom of the label is your VIN.

### Gross Vehicle Weight Rating (GVWR)

The GVWR is the total permissible weight of your vehicle including driver, passengers, vehicle, options and cargo. The label also specifies maximum capacities of front and rear GAWR. Total load must be limited so GVWR and front and rear GAWR are not exceeded.

### Payload

The payload of a vehicle is defined as the allowable load weight a truck can carry, including the weight of the driver, all passengers, options and cargo.

### Gross Axle Weight Rating (GAWR)

The GAWR is the maximum permissible load on the front and rear axles. The load must be distributed in the cargo area so that the GAWR of each axle is not exceeded.

Each axle GAWR is determined by the components in the system with the lowest load carrying capacity (axle, springs, tires or wheels). Heavier axles or suspension components sometimes specified by purchasers for increased durability do not necessarily increase the vehicle's GVWR.

### Tire Size

The tire size on the Vehicle Certification Label represents the actual tire size on your vehicle. Replacement tires must be equal to the load capacity of this tire size.

### Rim Size

This is the rim size that is appropriate for the tire size listed.

### Inflation Pressure

This is the cold tire inflation pressure for your vehicle for all loading conditions up to full GAWR.

## Curb Weight

The curb weight of a vehicle is defined as the total weight of the vehicle with all fluids, including vehicle fuel, at full capacity conditions, and with no occupants or cargo loaded into the vehicle. The front and rear curb weight values are determined by weighing your vehicle on a commercial scale before any occupants or cargo are added.

## Loading

The actual total weight and the weight of the front and rear of your vehicle at the ground can best be determined by weighing it when it is loaded and ready for operation.

The entire vehicle should first be weighed on a commercial scale to ensure that the GVWR has not been exceeded. The weight on the front and rear of the vehicle should then be determined separately to be sure that the load is properly distributed over the front and rear axle. Weighing the vehicle may show that the GAWR of either the front or rear axles has been exceeded but the total load is within the specified GVWR. If so, weight must be shifted from front to rear or rear to front as appropriate until the specified weight limitations are met. Store the heavier items down low and be sure that the weight is distributed equally. Stow all loose items securely before driving.

Improper weight distributions can have an adverse effect on the way your vehicle steers and handles and the way the brakes operate.

### WARNING!

Do not load your vehicle any heavier than the GVWR or the maximum front and rear GAWR. If you do, parts on your vehicle can break, or it can change the way your vehicle handles. This could cause you to lose control. Overloading can shorten the life of your vehicle.

## TRAILER TOWING

Trailer towing with this vehicle is not recommended.

## RECREATIONAL TOWING (BEHIND MOTORHOME, ETC.)

### TOWING THIS VEHICLE BEHIND ANOTHER VEHICLE

Towing Condition	Wheels OFF the Ground	Single-Speed Transmission
Flat Tow	NONE	NOT ALLOWED
Dolly Tow	Front	OK
	Rear	NOT ALLOWED
On Trailer	ALL	OK

#### NOTE:

- When towing your vehicle, always follow applicable state and provincial laws. Contact state and provincial Highway Safety offices for additional details.

- This vehicle must be towed on a dolly or vehicle trailer with the front wheels **OFF** the ground.

### CAUTION!

Towing this vehicle in violation of the above requirements can cause severe transmission damage. Damage from improper towing is not covered under the New Vehicle Limited Warranty.

## DRIVING TIPS

### ENERGY CONSUMPTION REDUCTION

Below are some useful tips that allow you to achieve a reduction in energy consumption of the high-voltage battery and a consequent increase in range.

#### Vehicle Maintenance

Checks and operations should be carried out in accordance with the "Service Schedule" (see the "Servicing and Maintenance" chapter).

#### Tires

Check the tire pressures at least once every four weeks: if the pressure is too low, electrical energy consumption levels increase as resistance to rolling is higher.



## Unnecessary Loads

Do not travel with an overloaded luggage compartment. The weight of the vehicle and its trim greatly affect electrical energy consumption and stability.

## Electric Devices

Use electrical devices only for the amount of time needed. The heated rear window, windshield wipers and heater fan require a considerable amount of energy; increasing the current uptake increases electrical energy consumption.

## Climate Control System

Using the climate control system will increase electrical energy consumption: use standard ventilation when the temperature outside permits.

## Devices For Aerodynamic Control

The use of non-certified devices for aerodynamic control may adversely affect air drag and electrical energy consumption levels.

## DRIVING ON SLIPPERY SURFACES

Information in this section will aid in safe controlled launches in adverse conditions.

### Acceleration

Rapid acceleration on snow covered, wet, or other slippery surfaces may cause the driving wheels to pull erratically to the right or left. This phenomenon occurs when there is a difference in the surface traction under the front (driving) wheels.

### WARNING!

Rapid acceleration on slippery surfaces is dangerous. Unequal traction can cause sudden pulling of the front wheels. You could lose control of the vehicle and possibly have a collision. Accelerate slowly and carefully whenever there is likely to be poor traction (ice, snow, wet, mud, loose sand, etc.).

### Traction

When driving on wet or slushy roads, it is possible for a wedge of water to build up between the tire and road surface. This is hydroplaning and may cause partial or complete loss of vehicle control and stopping ability. To reduce this possibility, the following precautions should be observed:

- Slow down during rainstorms or when the roads are slushy.
- Slow down if the road has standing water or puddles.
- Replace the tires when tread wear indicators first become visible.
- Keep tires properly inflated.
- Maintain sufficient distance between your vehicle and the vehicle in front of you to avoid a collision in a sudden stop.

### DRIVING THROUGH WATER

Driving through water more than a few inches/centimeters deep will require extra caution to ensure safety and prevent damage to your vehicle.

## Flowing/Rising Water

### WARNING!

Do not drive on or across a road or path where water is flowing and/or rising (as in storm run-off). Flowing water can wear away the road or path's surface and cause your vehicle to sink into deeper water. Furthermore, flowing and/or rising water can carry your vehicle away swiftly. Failure to follow this warning may result in injuries that are serious or fatal to you, your passengers, and others around you.

## Shallow Standing Water

Although your vehicle is capable of driving through shallow standing water, consider the following Cautions and Warnings before doing so.

### WARNING!

- Driving through standing water limits your vehicle's traction capabilities. Do not exceed 5 mph (8 km/h) when driving through standing water.
- Driving through standing water limits your vehicle's braking capabilities, which increases stopping distances. Therefore, after driving through standing water, drive slowly and lightly press on the brake pedal several times to dry the brakes.
- Failure to follow these warnings may result in injuries that are serious or fatal to you, your passengers, and others around you.

**CAUTION!**

- Always check the depth of the standing water before driving through it. Never drive through standing water that is deeper than the bottom of the tire rims mounted on the vehicle.
- Determine the condition of the road or the path that is under water and if there are any obstacles in the way before driving through the standing water.
- Do not exceed 5 mph (8 km/h) when driving through standing water. This will minimize wave effects.
- Driving through standing water may cause damage to your vehicle's drivetrain components. Always inspect your vehicle's fluids (i.e., engine oil, transmission, axle, etc.) for signs of contamination (i.e., fluid that is milky or foamy in appearance) after driving through standing water. Do not continue to operate the vehicle if any fluid appears contaminated, as this may result in further damage. Such damage is not covered by the New Vehicle Limited Warranty.
- Getting water inside your vehicle's engine can cause it to lock up and stall out, and cause serious internal damage to the engine. Such damage is not covered by the New Vehicle Limited Warranty.

**DRIVING STYLE****Top Speed**

Energy consumption considerably increases as speed increases. Maintain a constant speed, avoiding unnecessary braking and acceleration, which cost in terms of electrical energy consumption and emissions.

**Acceleration**

Accelerating violently will greatly affect electrical energy consumption and emissions. Acceleration should be gradual.

**CONDITIONS OF USE****Traffic And Road Conditions**

Heavy traffic with fast acceleration causes high electrical energy consumption. Winding mountain roads and rough road surfaces also adversely affect consumption.

# MULTIMEDIA

## UCONNECT SYSTEMS

For detailed information about your Uconnect 5 NAV With 10.25-inch Display, refer to your Uconnect Radio Instruction Manual.

### NOTE:

On some frequencies of the AM band reception may be disturbed by interference on the signal arriving at the system Uconnect™.

### NOTE:

Uconnect screen images are for illustration purposes only and may not reflect exact software for your vehicle.

## CYBERSECURITY

Depending on applicability, your vehicle may be able to send or receive information from a wired or wireless network. This information allows systems and features in your vehicle to function properly.

Your vehicle may be equipped with certain security features to reduce the risk of unauthorized and unlawful access to vehicle systems and wireless communications. Vehicle software technology continues to evolve over time and FCA US LLC, working with its suppliers, evaluates and takes appropriate steps as needed. As always, if you experience unusual behavior, contact an authorized dealer immediately, ➔ page 208, or refer to your Uconnect Radio Instruction Manual for additional contact information.

The risk of unauthorized and unlawful access to your vehicle systems may still exist, even if the most recent version of vehicle software (such as Uconnect software) is installed.

### WARNING!

- ONLY insert trusted media devices/components into your vehicle. Media of unknown origin could possibly contain malicious software, and if installed in your vehicle, it may increase the possibility for vehicle systems to be breached.
- As always, if you experience unusual vehicle behavior, contact an authorized dealer immediately.

### NOTE:

To help further improve user experience, features, stability, etc., and minimize the potential risk of a security breach, vehicle owners should routinely check [www.driveuconnect.com](http://www.driveuconnect.com) (US Residents) or [www.driveuconnect.ca](http://www.driveuconnect.ca) (Canadian Residents) to learn about available Uconnect software updates.

## UCONNECT SETTINGS

The Uconnect system uses a combination of buttons on the touchscreen and buttons on the faceplate located on the left of the dashboard. These buttons allow you to access and change Programmable Features. Many features can vary by vehicle and packages.

Your Uconnect system also have VOLUME/MUTE button on the central console.

Long press the VOLUME/MUTE button on the central console to turn off the Uconnect screen. Push the button again or tap the screen to turn the screen on.

Press the Back Arrow button to exit out of a Menu or certain option on the Uconnect system.

## CUSTOMER PROGRAMMABLE FEATURES



### Uconnect 5 NAV With 10.25-inch Display Buttons On The Touchscreen

Press the Vehicle button, then press the Settings tab on the top of the touchscreen. In this menu, the Uconnect system allows you to access all of the available programmable features.

**NOTE:**

- Only one touchscreen area may be selected at a time.
- Depending on the vehicle's options, feature settings may vary.

When making a selection, press the button on the touchscreen to enter the desired menu. Once in the desired menu, press and release the preferred setting option until a check mark appears next to the setting, showing that setting has been selected. Once the

setting is complete, press the Vehicle button to exit to the screen. Pressing the Up or Down Arrow button on the right side of the screen will allow you to toggle up or down through the available settings.

## Display

When the Display button is pressed on the touchscreen, the system will display the options related to the theme (if equipped), brightness, and color of the touchscreen. The available settings are:

**NOTE:**

Depending on the vehicle's options, feature settings may vary.

Setting Name	Description
Language	This setting will change the language of the Uconnect system and Instrument Cluster Display. The available languages are English, Français, Español, and Italiano.
Display Mode	This setting will allow you to set the brightness manually or have the system set it automatically. The "Auto" setting has the system automatically adjust the display brightness. The "Manual" setting will allow the user to adjust the brightness of the display.
Display Brightness Daytime	This setting will allow you to set the brightness when it is daytime. To access this setting, Display Mode must be set to "Manual". The "+" setting will increase the brightness; the "-" will decrease the brightness.
Display Brightness Nighttime	This setting will allow you to set the brightness when it is nighttime. To access this setting, Display Mode must be set to "Manual". The "+" setting will increase the brightness; the "-" will decrease the brightness.
Set Theme	This setting will allow you to adjust your theme. Setting options are "Theme 1, Theme 2, Theme 3, and Theme 4.
Units	This setting will allow you to change the units to "US", "Metric", or "Custom". The available options within Custom are "Speed" (MPH or km/h), "Distance" (mi or km), "Consumption" (mi/kWh, or km/kWh or kWh/100km or kWh/mi or MPGe), "Pressure" (psi, kPa, or bar), and "Temperature" (°C or °F) units of measurement independently.
Touchscreen Beep	This setting will allow you to turn the touchscreen beep on or off.
Show Main Category Bar Labels	This setting will allow the main category bar labels to be shown on or off.

Setting Name	Description
Navigation Next Turn Pop-ups Displayed in Cluster	This setting will display navigation prompts in the Instrument Cluster Display.
Phone Pop-ups Displayed In Cluster	This setting will display smartphone notifications and messages in the Instrument Cluster Display.

## My Profile

When the My Profile button is pressed on the touchscreen, the system displays options related to the vehicle's profiles.

### NOTE:

Depending on the vehicle's options, feature settings may vary.

Setting Name	Description
Language	This setting will change the language of the Uconnect system and Instrument Cluster Display. The available languages are English, Français, Español, and Italiano.
Display Mode	This setting will adjust the display for the radio to "Auto" or "Manual". "Manual" allows for more customization with the radio display.
Display Brightness Daytime	This setting will allow you to set the brightness when it is daytime. To access this setting, Display Mode must be set to "Manual". The "+" setting will increase the brightness; the "-" will decrease the brightness.
Display Brightness Nighttime	This setting will allow you to set the brightness when it is nighttime. To access this setting, Display Mode must be set to "Manual". The "+" setting will increase the brightness; the "-" will decrease the brightness.
Set Theme	This setting will allow you to adjust your theme. Setting options are Theme 1, Theme 2, Theme 3, and Theme 4.
Units	This setting will allow you to customize the units for "Speed" (MPH or km/h), "Distance" (mi or km), "Consumption" (mi/kwh, or km/kWh or kWh/100km or kWh/mi or MPGe), "Pressure" (psi, kPa, or bar), and "Temperature" (°C or °F) units of measurement independently.
Touchscreen Beep	This setting will allow you to turn the touchscreen beep on or off.
Show Main Category Bar Labels	This setting will allow the main category bar labels to be shown on or off.
Navigation Next Turn Pop-ups Displayed in Cluster	This setting will display navigation prompts in the Instrument Cluster Display.
Phone Pop-ups Displayed In Cluster	This setting will display smartphone notifications and messages in the Instrument Cluster Display.
Time Format	This setting will allow you to set the time format (AM/PM). Sync Time With GPS must be "Off" for this setting to be available. The "12 hrs" setting will set the time to a 12-hour format. The "24 hrs" setting will set the time to a 24-hour format.
Voice Options	This setting will allow you to change the voice options for the radio to "Male" or "Female".

Setting Name	Description
Wake Up Word	This setting will allow you to set the system "Wake Up" word. The available options are "Off", "Hey, Uconnect" and "Hey, Fiat".
Voice Barge-in	This setting will allow Voice Barge-in to be turned on or off.
Show Command List	This setting will allow the Command List to be shown on or off.
Navigation Settings	This setting will redirect to the list of Navigation settings. Refer to your Uconnect Radio Instruction Manual for further information.
Auto-On Driver Heated/Ventilated Seat & Heated Steering Wheel	This setting will activate the vehicle's comfort system and heated seats or heated steering wheel when the vehicle is remote started or ignition is started. The "Off" setting will not activate the comfort systems. The "All Start" setting will activate the comfort systems whenever the vehicle is started.
Radio Off Delay	This setting will keep certain electrical features running after the engine is turned off. When any door is opened, the electronics will deactivate. The available settings are "0 min" and "20 min".
Radio Off With Door	This setting will allow you to determine if the radio shuts off when any of the doors are opened.
Audio Settings	This setting will open the submenu, containing the audio settings → page 125.
App Drawer Favoriting Pop-ups	This setting will allow you to favorite app drawer pop-ups with "On" and "Off" options.
App Drawer Unfavoriting Pop-ups	This setting will allow you to unfavorite app drawer pop-ups with "On" and "Off" options.
New Text Message Pop-ups	This setting will allow you to have pop-up notifications for new text messages. Setting options are "On" and "Off".
Missed Calls Message	This setting will allow you to have pop-up notifications for missed calls. Setting options are "On" and "Off".
Navigation Pop-ups	This setting will allow you to have pop-up notifications for Navigation. Setting options are "On" and "Off".
Reset App Drawer to Default Order	This setting will reset the app drawer to its factory default layout.
Restore Settings to Default	This setting will return all the previously changed settings to their factory defaults.
More Profile Options	This setting will give access to more profile options.

## Safety/Driving Assistance

When the Safety/Driving Assistance button is pressed on the touchscreen, the system displays the options related to the vehicle's safety settings. These options will differ depending on the features equipped on the vehicle. The settings may display in list form or within subfolders on the screen. To access a subfolder, select the desired folder; the available options related to that feature will then display on the screen.

### NOTE:

Depending on the vehicle's options, feature settings may vary.

Setting Name	Description
<b>Autonomous Emergency Brake Control</b>	This submenu contains the following settings: AEB Control and AEB Control Sensitivity. The available options for AEB Control are "Off", "Only Warning", and "Warning + Active Braking". The options for AEB Control are "Near", "Med", and "Far".
<b>Forward Collision Warning — Located In Automatic Emergency Braking Submenu</b>	This setting will turn the Forward Collision Warning (FCW) system on or off. The "Off" setting will deactivate the FCW system. The "Warning Only" setting will provide only an audible chime when a collision is detected. The "Warning + Active Braking" setting will provide an audible chime and apply some brake pressure when a collision is detected.
<b>Forward Collision Warning Sensitivity — Located In Automatic Emergency Braking Submenu</b>	This setting will change the distance at which the Forward Collision Warning alert sounds. The "Medium" setting will have the FCW system signal when an object is in view, and the possibility of a collision is detected. The "Near" setting will have the FCW system signal when the object is closer to the vehicle. The "Far" setting will have the FCW system signal when an object is at a far distance from the vehicle.
<b>Pedestrian Emergency Braking — Located In Automatic Emergency Braking Submenu</b>	This setting will turn the Pedestrian Emergency Braking system on or off.
<b>Lane Management — Located In Active Lane Management</b>	This setting will activate the system that will alert the driver when a lane departure is detected. If selected, steering assist can be provided. The available options are "Vibration Only", "Steering Assist Only", and "Vibration + Steering Assist".
<b>Lane Control Warning — Located In Lane Control</b>	This setting will set the warning type for Active Lane Management. The available options are "Early", "Medium", and "Late".
<b>Lane Control Strength — Located In Lane Control</b>	This setting will set the strength of the steering wheel vibration. The available options are "Low", "Medium", and "High".
<b>LaneSense Warning — Located In LaneSense submenu</b>	This setting will set the warning type for LaneSense. The available options are "Early", "Medium", and "Late".
<b>LaneSense Strength — Located In LaneSense submenu</b>	This setting will set the strength of the LaneSense system. The available options are "Low", "Medium", and "High".



Setting Name	Description
<b>ParkSense</b>	This setting will change the type of ParkSense alert when a close object is detected. The "Sound Only" setting will provide an audible chime when an object is detected. The "Sound and Display" setting will provide both an audible chime and a visual display when an object is detected.
<b>Front ParkSense Volume</b>	This setting adjusts the volume of the Front ParkSense system. The available settings are "Low", "Medium", and "High".
<b>Rear ParkSense Volume</b>	This setting adjusts the volume of the Rear ParkSense system. The available settings are "Low", "Medium", and "High".
<b>Rear ParkSense Braking Assist</b>	This setting will provide braking assistance if the Rear ParkSense system senses a collision with an object.
<b>Active ParkSense Mode</b>	This setting will control Active ParkSense functionality between fully autonomous parking and semi-autonomous parking. The available options are "Full Auto" and "Steering Only".
<b>Active ParkSense Proximity Chime</b>	This setting will turn the Active ParkSense Proximity Chimes on or off. This setting is only available when Active ParkSense Mode is set to "Full Auto".
<b>Blind Spot Assist</b>	This setting will change the type of alert provided when an object is detected in the vehicle's blind spot. The "Off" setting will turn off Blind Spot Alert. The "Lights" setting will activate the Blind Spot Alert lights on the outside mirrors. The "Lights & Chime" setting will activate both the lights on the outside mirrors and an audible chime.
<b>Traffic Sign Assist</b>	This setting will turn Traffic Sign Assist on or off.
<b>Traffic Sign Assist Warning</b>	This setting will allow you to set the warning type related to the traffic sign. The available options are "Off", "Visual", and "Visual + Chime".
<b>New Speed Zone Indication</b>	This setting will allow you to set if the system will warn you that the speed limit has changed in an area. The available options are "Off", "Visual", and "Visual + Chime".
<b>Drowsy Driver Alert</b>	This setting will monitor the driver's driving habits and warn you of any changes, indicating that the driver may be drowsy. The available options are "On" and "Off".
<b>Highway Assist Steering Wheel Vibration</b>	This setting will vibrate the steering wheel when a lane departure is detected. The available options are "On" and "Off".
<b>Side Distance Warning</b>	This setting will turn the Side Distance Warning on or off and set how the system will communicate with the user. The "Off" setting will deactivate the system. The "Sound" setting will provide an audible chime to the user. The "Sound And Display" setting will provide both an audible chime and a visual display.

Setting Name	Description
Rear Seat Alert	When this setting is turned on and the rear doors are opened while the engine is running, or if the engine is turned on within 10 minutes of the door opening, a message will appear to check the rear seat when the vehicle is powered OFF.
Hill Start Assist	This setting will turn the Hill Start Assist system on or off.

## Clock & Date

When the Clock & Date button is pressed on the touchscreen, the system displays the different options related to the vehicle's internal clock.

### NOTE:

Depending on the vehicle's options, feature settings may vary.

Setting Name	Description
Sync Time With GPS	This setting will sync the time to the GPS receiver in the system. The system will control the time via the GPS location.
Set Time Hours	Under the Set Time submenu, this setting will allow you to set the hours. Sync Time With GPS must be off for this setting to be available. The "+" setting will increase the hours. The "-" setting will decrease the hours.
Set Time Minutes	Under the Set Time submenu, this setting will allow you to set the minutes. Sync Time With GPS must be off for this setting to be available. The "+" setting will increase the minutes. The "-" setting will decrease the minutes.
Time Format	This setting will allow you to set the time format (AM/PM). Sync Time With GPS must be off for this setting to be available. The "12 hrs" setting will set the time to a 12-hour format. The "24 hrs" setting will set the time to a 24-hour format. You will also be able to adjust the clock.
Show Time In Satus Bar	This setting will display the time in the radio status bar.
Set Date	This setting will allow you to set the date.
Show Time and Date During Screen Off	This setting will display the time and date when the radio is shut off.

## Phone/Bluetooth®

When the Phone/Bluetooth® button is pressed on the touchscreen, the system displays the options related to Bluetooth® connectivity from an external audio device or smartphone. The list of paired audio devices or smartphones can be accessed from this menu.

### NOTE:

Depending on the vehicle's options, feature settings may vary.

Setting Name	Description
<b>Device Manager</b>	This setting will open the Device Manager main screen.
<b>Do Not Disturb All</b>	This setting will open the Do Not Disturb All settings menu. The available options are "On" and "Off".
<b>Enable Two Active Phones</b>	This setting will enable or disable two active phones within the vehicle. The setting options are "On" and "Off".
<b>Phone Pop-Ups Displayed In Cluster</b>	This setting will activate phone message pop-ups in the Instrument Cluster Display.

## Voice

When the Voice button is pressed on the touchscreen, the system displays the options related to the vehicle's Voice Recognition feature.

### NOTE:

Depending on the vehicle's options, feature settings may vary.

Setting Name	Description
<b>Voice Options</b>	This setting will allow you to change the system's voice to either "Male" or "Female".
<b>Wake Up Word</b>	This setting will allow you to set the system's "Wake Up" word. The available options are "Off", "Hey, Uconnect", and "Hey, Fiat".
<b>Voice Barge-In</b>	This setting allows you to respond to a Voice Response before the statement is completed by the system. The available options are "On" and "Off".
<b>Show Command List</b>	This setting will allow you to turn the Command List on or off. The "Always" setting will always show the Command List. The "With Help" setting will show the Command List and provide a brief description of what the command does. The "Never" setting will turn the Command List off.

## Navigation

When the Navigation button is pressed on the touchscreen, the system displays options related to the vehicle's built-in Navigation system. These settings can change which icons display on the map, how "time to arrival is calculated", and route types.

For more information on Navigation and settings, refer to your Uconnect Radio Instruction Manual.

## Camera

When the Camera button is pressed on the touchscreen, the system displays the options related to the vehicle's camera features.

### NOTE:

Depending on the vehicle's options, feature settings may vary.

Setting Name	Description
<b>ParkView Backup Camera</b>	This setting will turn the ParkView Backup Camera on or off.
<b>ParkView Backup Camera Delay</b>	This setting will add a delay to the ParkView Backup Camera when shifting out of REVERSE.
<b>ParkView Backup Camera Active Guidelines</b>	This setting will turn the ParkView Backup Camera Active Guidelines on or off.
<b>Fixed ParkView Backup Camera Guidelines</b>	This setting will turn the Fixed ParkView Backup Camera Guidelines on or off.
<b>Surround View Camera Delay</b>	This setting will add a timed delay to the Surround View Camera when shifting out of REVERSE.
<b>Surround View Camera Guidelines</b>	This setting will turn the Surround View Camera Guidelines on or off.

## Mirrors & Wipers

When the Mirrors & Wipers button is pressed on the touchscreen, the system displays the option related to the vehicle's mirrors and wipers.

### NOTE:

Depending on the vehicle's options, feature settings may vary.

Setting Name	Description
<b>Rain Sensing Auto Wipers</b>	This setting will turn the Rain Sensing Auto Wipers on or off.

## Lights

When the Lights button is pressed on the touchscreen, the system displays the options related to the vehicle's exterior and interior lights.

### NOTE:

- When the "Daytime Running Lights" feature is selected, the daytime running lights can be turned on or off. This feature is only allowed by law in the country of the vehicle purchase.
- Depending on the vehicle's options, feature settings may vary.

Setting Name	Description
<b>Headlight Sensitivity</b>	This setting will allow you to set the sensitivity of the headlights depending on the amount of visible light. The greater the sensitivity set, the less the external light variation required to turn on the lights (e.g. with a setting on level 3 at sunset, the headlights turn on earlier than in levels 1 and 2). The available levels are "Level 1: Minimum Sensitivity", "Level 2: Medium Sensitivity", and "Level 3: Maximum Sensitivity".
<b>Headlight Off Delay</b>	This setting will allow you to set the amount of time it takes for the headlights to shut off after the vehicle is turned off. The available settings are "0 sec", "30 sec", "60 sec", and "90 sec".
<b>Headlight Illumination On Approach</b>	This setting will allow you to set the amount of time it takes for the headlights to shut off after the vehicle is unlocked. The available settings are "0 sec", "30 sec", "60 sec", and "90 sec".
<b>Auto Dim High Beams</b>	This setting will allow you to turn the Auto Dim High Beams on or off.
<b>Greeting Lights</b>	This setting will turn the Greeting Lights on or off.
<b>Daytime Running Lights</b>	This setting will allow you to turn the Daytime Running Lights on or off.
<b>Cornering Lights</b>	When this setting is selected, if the steering wheel rotation angle is large or the turn signal indicators are on, a light will turn on, on the relevant side to improve visibility at night.
<b>Headlight Dip</b>	This setting will lower the headlights when driving on the opposite side of the road. The available options are "On" and "Off".
<b>Flash Lights With Lock</b>	This setting will allow you to turn the flashing of the lights when the Lock button is pushed on the key fob on or off.

## Brakes

After pressing the Brakes button on the touchscreen, the following settings will be available:

### NOTE:

Depending on the vehicle's options, feature settings may vary.

Setting Name	Description
Hold 'n Go	This setting will turn the Hold 'n Go feature on or off.
Auto Park Brake	This setting will turn the Auto Park Brake on or off.
Brake Service	This setting will allow you to retract the brakes for servicing.

## Doors & Locks

When the Doors & Locks button is pressed on the touchscreen, the system displays the options related to locking and unlocking the vehicle's doors.

### NOTE:

Depending on the vehicle's options, feature settings may vary.

Setting Name	Description
Auto Door Locks	This setting will automatically lock the doors when the vehicle is in motion.
Auto Unlock On Exit	This setting will unlock the doors when any of the doors are opened from the inside.
Flash Lights With Lock	This setting will allow you to turn the flashing of the lights when the Lock button is pushed on the key fob on or off.
Sound Horn With Lock	This setting will sound the horn when the Lock button is pushed on the key fob. The "Off" setting will not sound the horn when the Lock button is pushed. The "1st Press" setting will sound the horn when the Lock button is pushed once. The "2nd Press" setting will sound the horn when the Lock button is pushed twice.
1st Press Of Key Fob Unlocks	This setting will change how many pushes of the Unlock button on the key fob are needed to unlock all the doors. The "Driver Door" setting will only unlock the driver door on the first push on the Unlock button. The "All Doors" setting will unlock all doors on the first push of the Unlock button.
Keyless Entry	This setting will allow you to turn the Keyless Entry feature (Keyless Enter 'n Go™) on or off.

Setting Name	Description
Auto Door Locks	This setting will allow you to change if the doors lock automatically when the vehicle reaches 15 mph (24 km/h).

## Seats & Comfort

When the Seats & Comfort button is pressed on the touchscreen, the system displays the option related to the vehicle's comfort systems when remote start has been activated or the vehicle has been started.

**NOTE:**

Depending on the vehicle's options, feature settings may vary.

Setting Name	Description
Auto-On Driver Heated/Ventilated Seat & Steering Wheel With Vehicle Start	This setting will activate the vehicle's comfort systems and heated seats or heated steering wheel when the vehicle is remote started or ignition is started. The "Off" setting will not activate the comfort systems. The "All Start" setting will activate the comfort systems whenever the vehicle is started.

## Key Off Options

When the Key Off Options button is pressed on the touchscreen, the system displays the options related to vehicle shutoff. These settings will only activate when the ignition is set to OFF.

**NOTE:**

Depending on the vehicle's options, feature settings may vary.

Setting Name	Description
Radio Off Delay	This setting will keep the radio running after the engine is turned off. When any door is opened, the electronics will deactivate. The available settings are "0 min" and "20 min".
Radio Off With Door	This setting will shut the radio off when the door is opened. The available settings are "On" and "Off".
Headlight Off Delay	This setting will allow you to set the amount of time the headlights remain on after the vehicle has been turned off. The "+" will increase the amount of time. The "-" will decrease the amount of time.

## Audio

When the Audio button is pressed on the touchscreen, the system displays options related to the vehicle's sound system. These settings can change the audio location within the vehicle, adjust the bass or treble levels, and auto-play settings from an audio device or smartphone.

### NOTE:

Depending on the vehicle's options, feature settings may vary.

Setting Name	Description
Balance/Fade	This setting will adjust audio levels from specific speakers in the front/back and left/right of the vehicle. The Speaker icon can be moved to set audio location.
Equalizer	This setting will adjust the "Bass", "Mid", and "Treble" ranges of the audio.
Speed Adjusted Volume	This setting will adjust audio volume as speeds increase. At a higher setting, the volume will increase more as the vehicle speeds up. The available settings are "Off", "1", "2", and "3".
Surround Sound	This setting will turn the Surround Sound system on or off.
AUX Volume Offset	This setting will tune the audio levels from a device connected through the AUX port. The available settings are "+" and "-".
Auto Play	This setting will automatically begin playing audio from a connected device.
Auto-On Radio	This setting will automatically turn the radio on when the vehicle is started. The available settings are "Off", "On", and "Recall Last". With Recall Last, the system resumes the previous task before vehicle shut off.
Radio Off With Door	This setting will keep the radio on when a door is opened or until the Radio Off Delay time is reached. The available settings are "On" and "Off".
Loudness	This setting improves the sound quality at lower volumes. The available options are "On" and "Off".
Volume Adjustment	This setting will allow you to set the audio volume levels for each option (Media, Phone, Navigation, etc.). You can set the volume between 0 and 38.

## Notifications

When the Notifications button is pressed on the touchscreen, the system displays the options related to Notifications for the system.

### NOTE:

Depending on the vehicle's options, feature settings may vary.



Setting Name	Description
Notification Sounds	This setting will turn off the Notification chime that plays when a new notification is sent. The options are "On" and "Off".
App Drawer Favoriting Pop-Ups	This setting turns the App Favorited Pop-Up on or off.
App Drawer Unfavoriting Pop-Ups	This setting turns the App Unfavorited Pop-Up on or off.
New Text Message Pop-Ups	This setting turns receiving/storing a pop-up for new text messages of any connected phone on or off.
Missed Calls Message	This setting turns receiving/storing a pop-up for missed calls of any connected phone on or off.
Navigation Pop-Ups	This setting turns receiving/storing predictive Navigation Pop-Ups on or off.

## SiriusXM® Setup

When the SiriusXM® Setup button is pressed on the touchscreen, the system displays the options related to SiriusXM® satellite radio. These settings can be used to skip specific radio channels and restart favorite songs from the beginning.

### NOTE:

- A subscription to SiriusXM® satellite radio is required for these settings to be functional.
- Depending on the vehicle's options, feature settings may vary.

Setting Name	Description
SiriusXM® Account, Profile, And Settings	This setting will redirect you to the SiriusXM® settings menu within the SiriusXM® menu.
Block Explicit	This setting will skip over content labeled as explicit. The available settings are "On" and "Off".

## Software Updates

When the Software Updates button is pressed on the touchscreen, the system will display the setting related to updating the Uconnect software.

### NOTE:

Depending on the vehicle's options, feature settings may vary.

Setting Name	Description
Software Downloads over Wi-Fi	This setting will allow software updates to happen over Wi-Fi. Selectable options for the setting are “On” and “Off”.

## System Information

When the System Information button is pressed on the touchscreen, the system displays the radio system information.

### NOTE:

Depending on the vehicle’s options, feature settings may vary.

Setting Name	Description
Version Information	This will display the current build number.
Software Licenses	This will display the software licensing information screen.

## Reset

When the Reset button is pressed on the touchscreen, the system displays the options related to resetting the Uconnect system back to its default settings. These settings can clear personal data and reset selected settings from other menus.

### NOTE:

Depending on the vehicle’s options, feature settings may vary.

Setting Name	Description
Restart Radio	This setting will reboot the radio.
Reset Apps Drawer To Default Order	This setting will return the apps drawer to the default order. The available options are “Yes” and “Cancel”. The X button can also be pressed to cancel the screen.
Restore Apps to Default Order	This setting will delete all of the installed apps if there is an issue with using or installing an app. The available options are “Back” and “Next”.
Restore Settings to Default	This setting will return all the previously changed settings to their factory defaults.
Clear Personal Data	This setting will display a pop-up that gives you the option to clear all personal data from the system, including Bluetooth® devices and presets.  <b>NOTE:</b> Performing this function may take several minutes to complete.

Setting Name	Description
Reset Wi-Fi Password For Projection	This setting will allow you to reset the vehicle's Wi-Fi password for smartphone projection. The available options are "Yes" and "Cancel". The X button can also be pressed to cancel the screen.
Factory Reset	This setting will restore the radio to its factory default settings.

## STEERING WHEEL AUDIO CONTROLS

The remote sound system controls are located on the rear surface of the steering wheel at the three and nine o'clock positions.

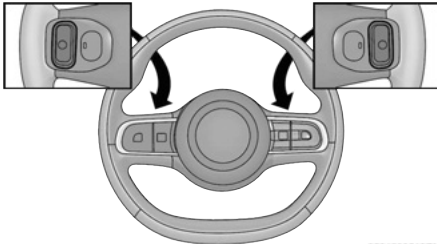

0501202513EM

### Remote Sound System Controls

The right-hand control is a rocker-type switch with a push button in the center and controls the volume and mode of the sound system. Pushing the top of the rocker switch will increase the volume, and pushing the bottom of the rocker switch will decrease the volume.

Pushing the right-hand control's center button will make the radio switch between the various modes available (AM/FM/SXM or Media, etc.).

The left-hand control is a rocker-type switch with a push button in the center. The function of the left-hand control is different depending on which mode you are in.

The following describes the left-hand control operation in each mode:

### RADIO OPERATION

Pushing the top of the switch will seek up for the next available station and pushing the bottom of the switch will seek down for the next available station.

The button located in the center of the left-hand control will tune to the next preset station that you have programmed in the radio presets.

### MEDIA MODE

Pushing the top of the switch skips to the next track on the selected media (AUX/USB/Bluetooth®). Pushing the switch up twice will go forward two tracks. Pushing the bottom switch goes to the beginning of the current track, or the beginning of the previous track if it is within eight seconds after the current track begins to play. Double pressing the bottom button switch will skip to the previous track if it is after eight seconds into the current track.

## RADIO OPERATION AND MOBILE PHONES

Under certain conditions, the mobile phone being on in your vehicle can cause erratic or noisy performance from your radio. This condition may be lessened or eliminated by relocating the mobile phone antenna. This condition is not harmful to the radio. If your radio performance does not satisfactorily clear by the repositioning of the antenna, it is recommended that the radio volume be turned down or off during mobile phone operation when not using Uconnect (if equipped).

## REGULATORY AND SAFETY INFORMATION

### USA/CANADA

Exposure to Radio Frequency Radiation

The radiated output power of the internal wireless radio is far below the FCC and IC radio frequency exposure limits. Nevertheless, the wireless radio will be used in such a manner that the radio is 8 inches (20 cm) or further from the human body.

The internal wireless radio operates within guidelines found in radio frequency safety standards and recommendations which reflect the consensus of the scientific community.

The radio manufacturer believes the internal wireless radio is safe for use by consumers. The level of energy emitted is far less than the electromagnetic energy emitted by wireless devices such as mobile phones. However, the use of wireless radios may be restricted in some situations or environments, such as aboard airplanes. If you are unsure of restrictions, you are encouraged to ask for authorization before turning on the wireless radio → page 211.

# SAFETY

## SAFETY FEATURES

### ANTI-LOCK BRAKE SYSTEM (ABS)

The ABS provides increased vehicle stability and brake performance under most braking conditions. The system automatically prevents wheel lock and enhances vehicle control during braking.

The ABS performs a self-check cycle to ensure that the ABS is working properly each time the vehicle is started and driven. During this self check, you may hear a slight clicking sound as well as some related motor noises.

The ABS is activated during braking when the system detects one or more wheels are beginning to lock. Road conditions such as ice, snow, gravel, bumps, railroad tracks, loose debris, or panic stops may increase the likelihood of ABS activation(s).

You also may experience the following normal characteristics when ABS activates:

- The ABS motor noise or clicking sounds (you may continue to hear for a short time after the stop).
- Brake pedal pulsations.
- A slight drop of the brake pedal at the end of the stop.

The ABS is designed to function with the Original Equipment Manufacturer (OEM) tires. Modification may result in degraded ABS performance.

#### WARNING!

- The ABS contains sophisticated electronic equipment that may be susceptible to interference caused by improperly installed or high output radio transmitting equipment. This interference can cause possible loss of Anti-Lock Braking capability. Installation of such equipment should be performed by qualified professionals.
- Pumping of the Anti-Lock Brakes will diminish their effectiveness and may lead to a collision. Pumping makes the stopping distance longer. Just press firmly on your brake pedal when you need to slow down or stop.
- The ABS cannot prevent the natural laws of physics from acting on the vehicle, nor can it increase braking or steering efficiency beyond that afforded by the condition of the vehicle brakes and tires or the traction afforded.
- The ABS cannot prevent collisions, including those resulting from excessive speed in turns, following another vehicle too closely, or hydroplaning.
- The capabilities of an ABS-equipped vehicle must never be exploited in a reckless or dangerous

*(Continued)*

#### WARNING!

manner that could jeopardize the user's safety or the safety of others.

### DROWSY DRIVER DETECTION

The Drowsy Driver Detections system detects when the driver is feeling fatigued and warns the driver to pull over and take a break.

#### To Activate/Deactivate

Drowsy Driver can be activated and deactivated through the Uconnect system by selecting the following in order:

1. "Vehicle"
2. "Settings"
3. "Safety & Driving Assistance"
4. "Attention Assist"

The system may also be activated or deactivated in the Instrument Cluster Display. See the Instrument Cluster Display Settings for more information,  page 60.

#### NOTE:

- The Drowsy Driver system will store the last setting (on or off) that was active during engine shut down. The next time the engine is started, the system

will automatically switch back to on or stay off, depending on its previous state.

- See the Uconnect Settings for more information, [page 113](#).

### WARNING!

The DDD system is an aid for driving and does not relieve the driver of the responsibility of driving the vehicle. If you experience fatigue while driving, pull over safely for a break without waiting for the DDD warnings. Only return to the road when you are in the right physical and mental condition to prevent endangering yourself and other drivers.

## System Warnings

The Drowsy Driver system intervenes if the camera in the center of the windshield detects signs of driver fatigue, such as variations in the vehicle's trajectory and approaching too closely to the side of the road.

A red  warning light will appear on the instrument cluster display along with a dedicated message, suggesting the driver to take a break. An acoustic warning will also be admitted.

If the driver **accepts** the system's recommendation and stops for a pause, by pressing the OK button on the left side of the steering wheel, the message will disappear from the display, and the symbol will be shown in the designated area of instrument panel until the next time the engine is started or stopped.

If the driver **ignores** the system's warning and continues driving without stopping, the message will remain on the instrument cluster display until the OK button

on the left side of the steering wheel is pressed. The warning light will also remain displayed in the designated area of the instrument cluster display.

### NOTE:

In the event of a Drowsy Driver system failure, an amber  symbol will appear in the instrument cluster display.

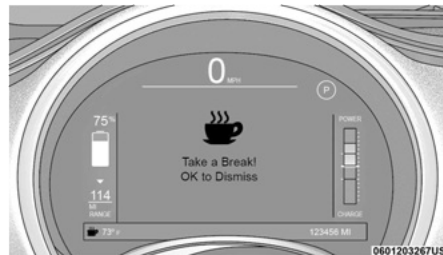

Drowsy Driver Detection Warning Message

## AUDIBLE PEDESTRIAN WARNING SYSTEM

Your vehicle is equipped with an Audible Pedestrian Warning system. The Audible Pedestrian Warning system uses distinct sounds to alert pedestrians that your vehicle is approaching. In addition, the module will indicate changes in vehicle speed by varying the relative volume.

The system uses an in-vehicle sound synthesizer with an external speaker located in the under-hood compartment. The Audible Pedestrian Warning system is active when the vehicle is not in PARK and remains active as long as the vehicle is travelling at a speed of 15 mph (25 km/h) or less.

### WARNING!

The Audible Pedestrian Warning system is not intended to avoid a collision. It is always the driver's responsibility to be attentive to the vehicle's distance between other vehicles, people, and objects, and most importantly brake operation to ensure safe operation of the vehicle under all road conditions. Your complete attention is always required while driving to maintain safe control of your vehicle. Failure to follow this warning could result in a collision or serious personal injury.

## REGENERATIVE BRAKING SYSTEM (RBS)

The RBS replenishes the vehicle's high voltage battery during deceleration, and is particularly useful in stop-and-go city traffic. The electric motors that propel the vehicle forward can operate as generators when braking. The RBS recharges the high voltage battery under certain braking conditions by recapturing energy that would otherwise be lost while braking. The electric power that is generated goes back into the high voltage battery for later use, for example, when acceleration is desired.

The RBS uses conventional hydraulic friction brakes, regenerative braking, or a combination, to slow the vehicle. If the system detects slippery conditions while braking, then **ONLY** friction is used to slow the vehicle. The RBS can result in extended life of the hydraulic service brakes; however, all inspection, scheduled maintenance, and service intervals for the vehicle brakes must be followed.

## REAR SEAT REMINDER ALERT (RSRA)

RSRA alerts you of the possible presence of an object, passenger, or pet in the rear seats through a visual and auditory notification. RSRA does not directly detect objects, passengers, or pets in the rear seats. When the previous conditions are met, RSRA displays the message “Check Rear Seat” on the instrument cluster display and sounds an auditory alert upon the driver placing the ignition in the OFF position to exit the vehicle.

### WARNING!

- Before exiting a vehicle, always come to a complete stop, then shift the automatic transmission into PARK and apply the parking brake.
- Always make sure the keyless ignition node is in the OFF position, key fob is removed from the vehicle and vehicle is locked.
- Never leave children alone in a vehicle, or with access to an unlocked vehicle. Leaving children in a vehicle unattended is dangerous for a number of reasons. A child or others could be seriously or fatally injured. Children should be warned not to touch the parking brake, brake pedal or the gear selector.
- Do not leave children or animals inside parked vehicles in hot weather. Interior heat buildup may cause serious injury or death.

## ELECTRONIC BRAKE CONTROL (EBC) SYSTEM

Your vehicle is equipped with an advanced Electronic Brake Control (EBC) system that includes the Drag Torque Control (DTC), Electronic Stability Control (ESC), Traction Control System (TCS), Panic Brake Assist (PBA), Hill Start Assist (HSA), Electronic Rollover Mitigation (ERM) and Hold ‘n’Go. These systems complement the Anti-Lock Brake System (ABS) by optimizing the vehicle braking capability during emergency braking maneuvers.

### Drag Torque Control (DTC) System

The DTC (Drag Torque Control) system prevents the drive wheels from possibly locking. For example, this could happen if the accelerator pedal is released suddenly in conditions with poor grip.

In these conditions, the exhaust braking effect could cause the drive wheels to slip, resulting in a loss of stability of the vehicle. In these situations, the DTC system intervenes, restoring torque to the motor in order to conserve stability and increase overall safety.

### Electronic Roll Mitigation (ERM)

ERM anticipates the potential for wheel lift by monitoring the driver’s steering wheel input and the speed of the vehicle. When ERM determines that the rate of change of the steering wheel angle and vehicle’s speed are sufficient to potentially cause wheel lift, it then applies the appropriate brake and may also reduce engine power to lessen the chance that wheel lift will occur. ERM can only reduce the chance of wheel lift occurring during severe or evasive driving

maneuvers; it cannot prevent wheel lift due to other factors, such as road conditions, leaving the roadway, or striking objects or other vehicles.

### NOTE:

ERM is disabled any time the ESC is in “Full Off” mode (if equipped). Refer to “Electronic Stability Control (ESC)” in this section for a complete explanation of the available ESC modes.

### WARNING!

Many factors, such as vehicle loading, road conditions, and driving conditions, influence the chance that wheel lift or rollover may occur. ERM cannot prevent all wheel lift or rollovers, especially those that involve leaving the roadway or striking objects or other vehicles. The capabilities of an ERM-equipped vehicle must never be exploited in a reckless or dangerous manner that could jeopardize the user’s safety or the safety of others.

## Electronic Stability Control (ESC)

ESC enhances directional control and stability of the vehicle under various driving conditions. ESC corrects for over/under steering of the vehicle by applying the brake of the appropriate wheel(s) to counteract the previous conditions listed. Engine power may also be reduced to help the vehicle maintain the desired path.

- Oversteer – when the vehicle is turning more than appropriate for the steering wheel position.
- Understeer – when the vehicle is turning less than appropriate for the steering wheel position.

ESC uses sensors in the vehicle to determine the vehicle path intended by the driver and compares it to the actual path of the vehicle. When the actual path does not match the intended path, ESC applies the brake of the appropriate wheel to assist in counteracting the oversteer or understeer condition.

#### WARNING!

- Electronic Stability Control (ESC) cannot prevent the natural laws of physics from acting on the vehicle, nor can it increase the traction afforded by prevailing road conditions. ESC cannot prevent accidents, including those resulting from excessive speed in turns, driving on very slippery surfaces, or hydroplaning. ESC also cannot prevent accidents resulting from loss of vehicle control due to inappropriate driver input for the conditions. Only a safe, attentive, and skillful driver can prevent accidents. The capabilities of an ESC equipped vehicle must never be exploited in a reckless or dangerous manner which could jeopardize the user's safety or the safety of others.
- Vehicle modifications, or failure to properly maintain your vehicle, may change the handling characteristics of your vehicle, and may negatively affect the performance of the ESC system. Changes to the steering system, suspension, braking system, tire type and size or wheel size may adversely affect ESC performance. Improperly inflated and unevenly worn tires may also degrade ESC performance. Any vehicle modification or poor vehicle maintenance that reduces the effectiveness of the ESC system can increase the

*(Continued)*

#### WARNING!

risk of loss of vehicle control, vehicle rollover, personal injury and death.

### ESC Operating Modes



The ESC OFF button is located in the left side of the instrument panel.

#### ESC On

This mode is the normal operating mode for ESC equipped vehicles. Whenever the vehicle is started, the ESC system will be in this mode. This mode should be used for most driving situations. ESC should only be turned off for the following specific reasons.

#### ESC Partial Off

This mode is entered by momentarily pushing the ESC OFF button.

When in the "Partial Off" mode, the TCS portion of ESC, except for the "limited slip" feature described in the TCS section, has been disabled and the ESC OFF Indicator Light will be illuminated. When in the "Partial Off" mode, ESC will operate without engine torque management. This mode is intended to be used if the vehicle is in deep snow, sand or gravel conditions and more wheel spin than ESC would normally allow is required to gain traction. To turn ESC on again, momentarily push the ESC OFF button. This will restore the normal "ESC On" mode of operation.

#### WARNING!

- When in "Partial Off" mode, the TCS functionality of ESC, except for the limited slip feature described in the TCS section, has been disabled and the ESC OFF Indicator Light will be illuminated. When in "Partial Off" mode, the engine power reduction feature of TCS is disabled, and the enhanced vehicle stability offered by the ESC system is reduced.
- Trailer Sway Control (TSC) is disabled when the ESC system is in the "Partial Off" mode.

#### NOTE:

To improve the vehicle's traction when driving with snow chains, or starting off in deep snow, sand or gravel, it may be desirable to switch to the "Partial Off" mode by pushing the ESC OFF button. Once the situation requiring ESC to be switched to the "Partial Off" mode is overcome, turn ESC back on by momentarily pushing the ESC OFF button. This may be done while the vehicle is in motion.

### ESC Activation/Malfunction Indicator Light And ESC OFF Indicator Light



The ESC Activation/Malfunction Indicator Light in the instrument cluster will come on when the ignition is turned to the ON/RUN mode. It should go out with the engine running. If the ESC Activation/Malfunction Indicator Light comes on continuously with the engine running, a malfunction has been detected in the ESC system. If this light remains on after several ignition cycles, and the vehicle has been driven several miles (kilometers)



at speeds greater than 30 mph (48 km/h), see an authorized dealer as soon as possible to have the problem diagnosed and corrected.

The ESC Activation/Malfunction Indicator Light starts to flash as soon as the tires lose traction and the ESC system becomes active. The ESC Activation/Malfunction Indicator Light also flashes when TCS is active. If the ESC Activation/Malfunction Indicator Light begins to flash during acceleration, ease up on the accelerator and apply as little throttle as possible. Be sure to adapt your speed and driving to the prevailing road conditions.



The ESC OFF Indicator Light indicates that the Electronic Stability Control (ESC) is in a reduced mode.

#### NOTE:

- The ESC Activation/Malfunction Indicator Light and the ESC OFF Indicator Light come on momentarily each time the ignition switch is placed in the ON/RUN position.
- Each time the ignition is placed in the ON/RUN position, the ESC system will be on even if it was turned off previously.
- The ESC system will make buzzing or clicking sounds when it is active. This is normal; the sounds will stop when ESC becomes inactive following the maneuver that caused the ESC activation.

## Hold 'n' Go

It is an integral part of the ESC system and keeps the car braked in all conditions. The Hold 'n' Go function can be activated from the panel in NORMAL mode;

it is always active in RANGE and SHERPA modes. If activated, after detecting that the car is stationary and the brake pedal has been released, the Hold 'n' Go function keeps the vehicle braked. You can now remove your foot from the brake pedal. When the driver lightly touches the accelerator pedal, the Hold 'n' Go function releases the brake again, leaving the car free to move. If the car is stationary and one of the following conditions required by the Hold 'n' Go function is changed:

- Driver's door closed
- Driver's seat belt not fastened

Then, the function is deactivated and the EPB is automatically engaged.

#### WARNING!

The intelligent technology of the Hold 'n' Go function cannot overcome the limits imposed by physical laws and only works within the limits of the system. The increased comfort offered by the Hold 'n' Go function must never cause the driver to take risks that could compromise safety.

## Hill Start Assist (HSA)

The HSA system is designed to assist the driver when starting a vehicle from a stop on a hill. HSA will maintain the level of brake pressure the driver applied for a short period of time after the driver takes their foot off of the brake pedal. If the driver does not apply the throttle during this short period of time, the system will release brake pressure and the vehicle will roll down the hill. The system will release brake pressure in proportion to the amount of throttle applied as the vehicle starts to move in the intended direction of travel.

## HSA Activation Criteria

The following criteria must be met in order for HSA to activate:

- The vehicle must be stopped.
- The vehicle must be on a 6% (approximate) grade or greater hill.
- Gear selection matches vehicle uphill direction (i.e., vehicle facing uphill is in forward gear; vehicle backing uphill is in REVERSE gear).

HSA will work in REVERSE and all forward gears when the activation criteria have been met. The system will not activate if the vehicle is placed in NEUTRAL or PARK.

#### WARNING!

There may be situations on minor hills with a loaded vehicle, or while pulling a trailer, when the system will not activate and slight rolling may occur. This could cause a collision with another vehicle or object. Always remember the driver is responsible for braking the vehicle.

## Panic Brake Assist (PBA)

The PBA system is designed to improve the car's braking capacity during emergency braking. The system detects emergency braking by monitoring the speed and force with which the brake pedal is pressed, and consequently applies the optimal brake pressure.

This can reduce the braking distance: the PBA system therefore completes the ABS.

Maximum assistance from the PBA system is obtained by pressing the brake pedal very quickly. In addition, the brake pedal should be pressed continuously during braking, avoiding intermittent presses, to get the most out of the system. Do not reduce pressure on the brake pedal until braking is no longer necessary. The PBA system is deactivated when the brake pedal is released.

#### WARNING!

- The PBA system cannot overrule the natural laws of physics, and cannot increase the grip available according to the condition of the road.
- The PBA system cannot prevent accidents, including those due to excessive speed on corners, driving on low-grip surfaces or aquaplaning.
- The capability of the PBA system must never be tested irresponsibly and dangerously, in such a way as to compromise the safety of the driver, the other occupants of the car or any other road user.

### Traction Control System (TCS)

TCS monitors the amount of wheel spin of each of the driven wheels. If wheel spin is detected, the TCS may apply brake pressure to the spinning wheel(s) and/or reduce engine power to provide enhanced acceleration and stability. A feature of the TCS, Brake Limited Differential (BLD) functions similarly to a limited slip differential and controls the wheel spin across a driven axle. If one wheel on a driven axle is spinning faster

than the other, the system will apply the brake of the spinning wheel. This will allow more engine torque to be applied to the wheel that is not spinning. BLD may remain enabled even if TCS and ESC are in reduced modes.

## AUXILIARY DRIVING SYSTEMS

### BLIND SPOT MONITORING (BSM) — IF EQUIPPED

The BSM system uses radar sensors, located inside the front and rear fascia/bumper, to detect highway licensable vehicles (automobiles, trucks, motorcycles, etc.) that enter the blind spot zones from the rear/front/side of the vehicle.

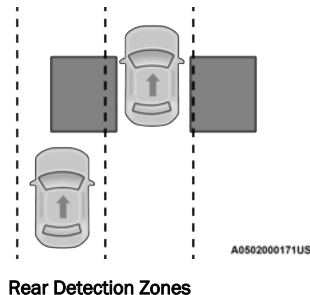

When the vehicle is started, the BSM Warning Light will momentarily illuminate in both outside rearview mirrors to let the driver know that the system is operational. The BSM system sensors operate when the vehicle is in any forward gear and enters standby mode when the vehicle is in PARK.

The BSM system monitors the detection zones on both sides of the vehicle when the vehicle speed reaches approximately 9 mph (15 km/h) or higher and will alert the driver of vehicles in these areas. It is temporarily deactivated at a speed greater than approximately 84 mph (140 km/h).

#### NOTE:

The BSM system DOES NOT alert the driver about rapidly approaching vehicles that are outside the detection zones.

The BSM system can become blocked if snow, ice, mud, or other road contaminations accumulate on the rear fascia/bumper where the radar sensors are located. The system may also detect blockage if the vehicle is operated in areas with extremely low radar returns such as a desert or parallel to a large elevation drop. If blockage is detected, a "Blind Spot Temporarily Unavailable, Sensor Blocked" message will display in the cluster, both mirror lights will illuminate, and BSM and RCP alerts will not occur. This is normal operation. The system will automatically recover and resume function when the condition clears or when an ignition cycle occurs. To minimize system blockage, do not block the area of the rear fascia/bumper where the radar sensors are located with foreign objects (bumper stickers, bicycle racks, etc.) and keep it clear of road contaminations.



Radar Sensors Location

The BSM system will provide a visual alert in the appropriate side view mirror based on a detected object when enabled. If the turn signal is then activated, and it corresponds to an alert present on that side of the vehicle, an audible chime will also be sounded when chimes are enabled. In addition to the audible alert the radio (if on) will also be muted during the chime event → page 138.

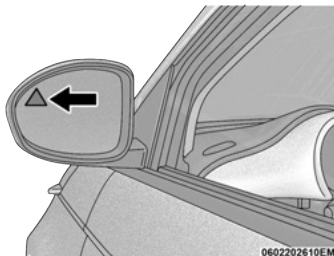

Warning Light Location

The BSM system monitors the detection zone from three different entry points (side, rear, front) while driving to see if an alert is necessary. The BSM system will issue an alert during these types of zone entries.

#### Entering From The Side

Vehicles that move into your adjacent lanes from either side of the vehicle.

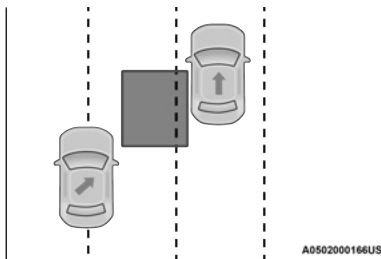

Side Monitoring

#### Entering From The Rear

Vehicles that come up from behind your vehicle on either side and enter the rear detection zone with a relative speed of less than 18 mph (30 km/h).

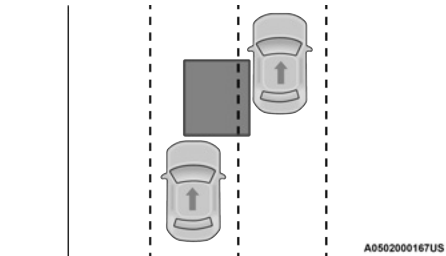

Rear Monitoring

#### Overtaking Traffic

If you pass another vehicle slowly with a relative speed less than 10 mph (16 km/h), the warning light will be illuminated. If the difference in speed between the two vehicles is greater than 10 mph (16 km/h), the warning light may not illuminate.

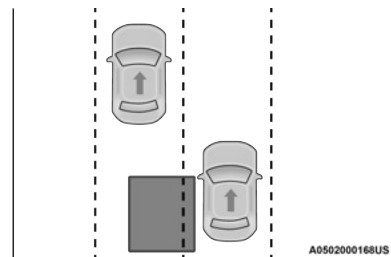

Overtaking/Approaching

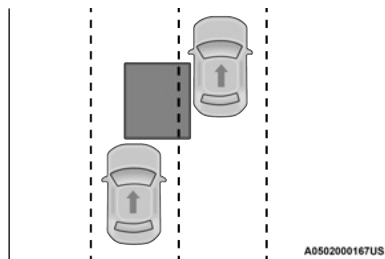

### Overtaking/Passing

The BSM system is designed not to issue an alert on stationary objects such as guardrails, posts, walls, foliage, berms, etc. However, occasionally the system may alert on such objects. This is normal operation and your vehicle does not require service.

The BSM system will not alert you of objects that are traveling in the opposite direction of the vehicle in adjacent lanes → page 211.

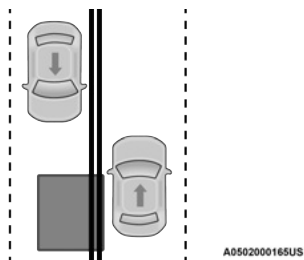

### Opposing Traffic

#### WARNING!

The Blind Spot Monitoring system is only an aid to help detect objects in the blind spot zones. The BSM system is not designed to detect pedestrians, bicyclists, or animals. Even if your vehicle is equipped with the BSM system, always check your vehicle's mirrors, glance over your shoulder, and use your turn signal before changing lanes. Failure to do so can result in serious injury or death.

### Blind Spot Modes

Blind Spot Alert has three selectable modes of operation that are available in the Uconnect system under "Safety & Driving Assistance".

#### Blind Spot Alert Lights Only (Default Setting)

When operating in Lights Only mode, the BSM system will provide a visual alert in the appropriate side view mirror based on a detected object. Whenever an audible alert is requested, the radio is muted for the duration of the chime.

#### Blind Spot Alert Lights/Chime

When operating in Blind Spot Alert Lights/Chime mode, the BSM system will provide a visual alert in the appropriate side view mirror based on a detected object. If the turn signal is then activated, and it corresponds to an alert present on that side of the vehicle, an audible chime will also be sounded. Whenever a turn signal and detected object are present on the same side at the same time, both the visual and audible alerts will be issued. In addition to the audible alert the radio (if on) will also be muted.

#### Blind Spot Alert Off

When the BSM system is turned off, there will be no visual or audible alerts from the BSM system.

#### NOTE:

The BSM system will store the current operating mode when the vehicle is shut off. Each time the vehicle is started the previously stored mode will be recalled and used.

#### Blocked Sensor

If the system detects degraded performance due to contamination or foreign objects, a message will warn you of a blocked sensor and the warning indicators in side view mirrors will be illuminated. The warning indicators will remain illuminated until blockage clearing conditions are met. First clear the fascia/bumper area around the sensors of the blockage. After removing the blockage, reset the system by cycling the ignition from ON/RUN to OFF and then back ON/RUN.

### FORWARD COLLISION WARNING (FCW) WITH MITIGATION — IF EQUIPPED

The FCW with Mitigation system uses a camera mounted in the center of the windshield that has the capability to take action in the presence of vehicles, cyclists, and pedestrians. In the event of an imminent collision, the system intervenes by automatically applying the car's brakes to either prevent the impact or reduce its severity.

The system communicates with the driver through both audible and visual signals displayed on the instrument panel.

When there is a risk of collision and the system detects no intervention from the driver, it initiates automatic braking to assist in decelerating the car and mitigating a potential frontal collision (automatic braking).

If the system senses that the driver's action on the brake pedal is insufficient, it may intervene to enhance the effectiveness of the braking system, thereby further reducing the car's speed (additional assistance in braking stage). The system will refrain from intervening if it recognizes that the driver has assumed control of the car and is attentive to the situation and the possibility of a collision.



FCW Message



When the system determines a collision with the vehicle in front of you is no longer probable, the warning message will be deactivated.

The vehicle is equipped with a "creeping" function, which allows it to resume movement a few seconds after coming to an automatic stop.

#### NOTE:

After the vehicle comes to a stop, the brake calipers may remain locked for approximately 2 seconds as a safety measure. If the car moves slightly, press the brake pedal.

#### Activation and Deactivation

The Forward Collision Warning system can be deactivated and reactivated within the Uconnect system  page 113 or through the instrument cluster display  page 57.

The system offers three activation levels:

#### NOTE:

- **Warning + Active Braking (system active):** the system provides visual and acoustic warnings, automatic braking, and additional assistance in the braking stage when the driver fails to brake sufficiently in event of a potential frontal collision.
- **Only Warning (system partially active):** the system delivers visual and acoustic warnings but does not provide automatic braking or additional braking assistance when the driver either doesn't brake at all or doesn't apply sufficient braking force in the presence of a potential frontal accident.
- **Off (system deactivated):** the system does not issue visual or acoustic warnings, engage in automatic braking, or additional assistance in the braking stage. The system does not provide any indication of a potential collision.

#### WARNING!

Forward Collision Warning (FCW) is not intended to avoid a collision on its own, nor can FCW detect every type of potential collision. The driver has the responsibility to avoid a collision by controlling the vehicle via braking and steering. Failure to follow this warning could lead to serious injury or death.

#### FCW Settings

##### Activation and Deactivation

The system will retain the last state (Only Warning, Warning plus Active Braking, or Off) that was active during engine shut down. The next time the engine is started, the system will either be active or remain off.

The system can be deactivated manually through the instrument cluster display or the Uconnect settings. Following deactivation, the system will not provide warnings to the driver about potential accidents with preceding vehicles, regardless of the previously selected setting. The system can be reactivated through the Uconnect settings or instrument cluster display.

The minimum speed for FCW activation is 3 mph (5 km/h).

The system is active under the following conditions:

#### NOTE:

- The system is activated correctly.
- It has not been deactivated within the instrument cluster display or Uconnect settings.
- The ignition device must be in the ENGINE position.
- The vehicle's speed is greater than 3 mph (5 km/h).

## Changing FCW Sensitivity And Operating Status

The FCW Sensitivity and Active Braking status are programmable through the Uconnect system ⇨ page 113 or instrument cluster display ⇨ page 57.

There are three available options: "Near", "Med", and "Far"

The default sensitivity of FCW is the "Medium" setting. In this mode, the system alerts the driver to a potential collision with the vehicle in front when that vehicle is at a standard distance, falling between the other two settings. This provides the driver with a reaction time that's longer than the "Near" setting but shorter than the "Far" setting when dealing with a possible accident.

By changing the FCW status setting to "Near", the system provides possible collision warnings on objects closer to the vehicle. This results in later warnings and provides less reaction time than the "Far" and "Medium" settings, which allows for a more dynamic driving experience.

By changing the FCW status setting to "Far", the system provides possible collision warnings on objects farther away. This results in earlier warnings and provides the most reaction time to avoid possible collisions.

### NOTE:

The "Far" setting may result in a greater number of FCW possible collision warnings experienced.

### NOTE:

The "Near" setting may result in a lesser number of FCW possible collision warnings experienced.

### NOTE:

- Changing the FCW status to "Only Warning" prevents the system from providing additional brake support if the driver is not braking adequately in the event of a potential frontal collision, but maintains the audible and visual warnings.
- Changing the FCW status to "Off" prevents the system from providing autonomous braking, or additional brake support if the driver is not braking adequately in the event of a potential frontal collision.
- The system will retain the last setting selected by the driver after ignition shut down.
- FCW may not react to irrelevant objects such as overhead objects, ground reflections, objects not in the path of the vehicle, stationary objects that are far away, oncoming traffic, or leading vehicles with the same or higher rates of speed.

## FCW Limited Warnings

### Function Temporarily Not Available

If the failure warning light illuminates, it indicates that a condition temporarily disabling the system's operation might have occurred. Weather-related factors like heavy rain, fog, or the low sun on the horizon could be the primary reasons for this temporary impairment.

Although the vehicle can still be driven in normal conditions, the system may be temporarily unavailable.

Once the conditions that limit the system's functions have resolved, it will return to its normal and complete operation. If the fault persists, contact an authorized dealer for further assistance.

### Warning Of System Disabling Due To An Obstruction

If a dedicated message is displayed, it indicates that a condition disabling the system may have occurred. The likely cause for this deactivation is an obstruction in the camera's view. If an obstruction is detected, it's advised to clean the area of the windshield where the FCW sensor is and check if the message disappears.

Although the vehicle can still be driven in normal conditions, the system may be temporarily unavailable.

Once the conditions that limit the system's functions have resolved, it will return to its normal and complete operation. If the fault persists, contact an authorized dealer for further assistance.

## Service FCW Warning

If the system turns off, and the instrument cluster display reads "FCW Unavailable Service Required", there is an internal system fault. Although the vehicle is still driveable under normal conditions, have the system checked by an authorized dealer as soon as possible.

## Driving in Special Conditions

### NOTE:

System intervention may be unexpected or delayed. In such situations, it is crucial for the driver to exercise extreme caution and maintain control of the car to ensure safe driving. Some examples of specific driving conditions include:

- Driving close to a bend.
- Vehicles with smaller dimensions or those not staying within their driving lane.
- Lane changes by other vehicles.

- Vehicles travelling at right angles to the vehicle.

**NOTE:**

In particularly complex traffic conditions, the driver can manually deactivate the system through the Uconnect settings or the instrument cluster display.

**DRIVING CLOSE TO A BEND**

When entering or exiting a wide curve, the system may detect a car in front of you that is not traveling in the same lane. In these situations, the system might initiate an intervention.

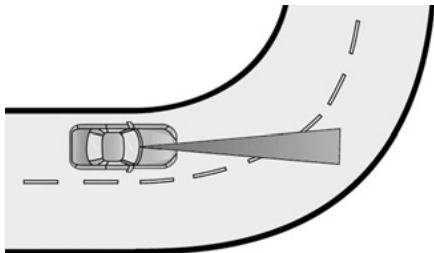
**Driving On A Bend****NARROW OR MISALIGNED VEHICLES**

The system has limitations in detecting cars that are positioned in front of the car but outside the camera's field of vision. As a result, it may not respond to smaller vehicles, such as motorcycles.

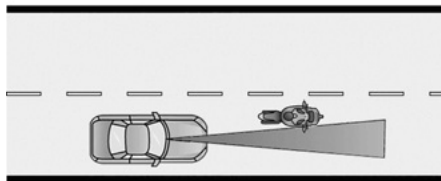

0434203256EM

**Narrow Vehicle Example****PEDESTRIAN/CYCLIST DETECTION**

While driving, when there's a potential collision risk with a pedestrian or cyclist, the system will show a warning message specifying the direction of obstacle detection and, if required, engage the brakes.

**LANE CHANGING BY OTHER VEHICLES**

Cars that suddenly change lanes, entering the same lane as your car and then moving into the camera's field of vision, can trigger the system to intervene.

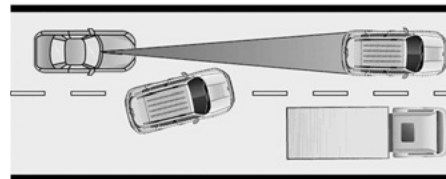
**Lane Changing Example****INDIRECT TIRE PRESSURE MONITORING SYSTEM (iTMS)**

The vehicle is equipped with the iTMS (indirect Tire Pressure Monitoring System) which monitors the tire inflation status.

The iTMS will warn the driver of a low tire pressure based on the vehicle recommended cold tire pressure  
 ⇨ page 196.

**CAUTION!**

- If the iTMS system signals a pressure drop on the tires, it is recommended to check the pressure on all four tires.
- The iTMS does not relieve the driver from the obligation to check the tire pressure every month; it is not even to be considered a replacement system for maintenance or a safety system.

*(Continued)*

**CAUTION!**

- Tire pressure must be checked with tires cold. Should it become necessary for whatever reason to check pressure with warm tires, do not reduce pressure even though it is higher than the prescribed value, but repeat the check when tires are cold.
- The iTPMS cannot indicate sudden tire pressure drops (for example when a tire bursts). In this case, stop the vehicle, braking with caution and avoiding abrupt steering.
- The system only warns that the tire pressure is low: it is not able to inflate them.
- Insufficient tire inflation increases electrical energy consumption, reduces the tread duration and may affect your ability to drive safely.

The tire pressure will vary with temperature by about 1 psi (7 kPa) for every 12° F (6.5° C). This means that when the outside temperature decreases, the tire pressure will decrease. Tire pressure should always be set based on cold inflation tire pressure. This is defined as the tire pressure after the vehicle has not been driven for at least three hours, or driven less than 1 mile (1.6 km) after a three-hour period. The tire pressure will also increase as the vehicle is driven — this is normal and there should be no adjustment for this increased pressure.

For information on how to properly inflate the vehicle's tires, see ➞ page 196.

The iTPMS will warn the driver of a low tire pressure if the tire pressure falls below the low pressure warning

threshold for any reason, including low temperature effects, or natural pressure loss through the tire.

The iTPMS will continue to warn the driver of low tire pressure as long as the condition exists, and will not turn off until the tire pressure is at or above recommended cold tire pressure. Once the low tire pressure warning has been illuminated, the tire pressure must be increased to the recommended cold tire pressure and a reset procedure performed in order for the TPMS Warning Light to be turned off.

**NOTE:**

When filling warm tires, the tire pressure may need to be increased up to an additional 4 psi (28 kPa) above the recommended cold placard pressure in order to turn the TPMS Warning Light off.

The system will automatically update and the TPMS Warning Light will extinguish once the updated tire pressures have been received. The vehicle may need to be driven for up to 20 minutes above 50 mph (80 km/h) to receive this information.

For example, your vehicle has a recommended cold (parked for more than three hours) tire pressure of 36 psi (248 kPa). If the ambient temperature is 68° F (20° C) and the measured tire pressure is 28 psi (193 kPa), a temperature drop to 20° F (-7° C) will decrease the tire pressure to approximately 24 psi (165 kPa). This tire pressure is sufficiently low enough to turn on the TPMS Warning Light. Driving the vehicle may cause the tire pressure to rise to approximately 28 psi (193 kPa), but the TPMS Warning Light will still be on. In this situation, the TPMS Warning Light will turn off only after the tires have been inflated to the vehicle's recommended cold tire pressure value and a reset procedure performed.

**Tire Pressure Monitoring System Low Pressure Warnings**

The TPMS Warning Light will illuminate in the instrument cluster, and an audible chime will be activated, when one or more of the four active road tire pressures are low. In addition, the instrument cluster will display a graphic display of the pressure value(s) with the low tire(s) in a different color ➞ page 57.

**NOTE:**

Your system can be set to display pressure units in PSI, BAR, or kPa.

**Low Tire Pressure Monitoring System Display**

Should a low tire condition occur on any of the four active road tire(s), you should stop as soon as possible, and inflate the low tire(s) that is in a different color on the graphic display to the vehicle's recommended cold tire pressure.



**NOTE:**

When filling warm tires, the tire pressure may need to be increased up to an additional 4 psi (28 kPa) above the recommended cold placard pressure in order to turn the TPMS Warning Light off.

The system will automatically update, the graphic display of the pressure value(s) will return to its original color and the TPMS Warning Light will extinguish once the updated tire pressure(s) have been received. The vehicle may need to be driven for up to 20 minutes above 50 mph (80 km/h) to receive this information.

**RESET Procedure**

The iTMS needs an initial "selflearning" phase (with length depending on the driving style and road conditions: optimal conditions being driving on a straight road at 50 mph (80 km/h) for at least 20 minutes) which starts when the RESET procedure is carried out manually.

The RESET procedure must be carried out:

- each time tire pressure is modified;
- when even only one tire is changed;
- when tires are rotated/inverted;
- when the space-saver wheel is fitted.

Before carrying out the RESET procedure, inflate the tires to the rated pressure values specified in the inflation pressure table see ➞ page 194.

If the RESET is not carried out, in all above cases, the warning light may give false indications on one or more tires.

To carry out the RESET procedure, with the car stopped and the ignition device at ON/RUN, use the Main Menu as follows:

- go to "Vehicle info" and then to "Reset tire pressure";
- press the "OK" and hold down (more than 2 seconds);
- the display will show the procedure progress (with a graphic bar) until the RESET is completed.

At the end of the RESET procedure the display will show the "Reset saved" message, indicating that the self-learning has been started and you will hear an acoustic warning.

If the self-learning procedure of the iTMS system has not been carried out correctly, no warning is provided.

**Operating Conditions**

The system is active for speeds above 9 mph (15 km/h).

In a few situations such as sporty driving, particular conditions of the road surface (e.g. icy, snowy, unsurfaced roads) the signalling may be delayed or partial in detecting the contemporary deflation of more than one tire.

Under special conditions (e.g. car loaded asymmetrically on one side, towing a trailer, damaged or worn tire, fitting the space-saver wheel, use of the "Fix&Go" tire repair kit, fitting snow chains, fitting different tires on the axles) the system may provide false indications or be temporarily deactivated.

If the system is temporarily deactivated the warning light flashes for about 75 seconds and then is

continuously on; at the same time, the display shows the shape of the car and the symbols "- -" will appear next to each tire.

This warning is displayed also after the engine has been switched off and then on again if the correct operating conditions are not restored.

In the case of abnormal signals, it is recommended to perform the RESET procedure. If the indications appear again after a successful RESET, check that the tires used on all four wheels are the same and that the tires are not damaged. As soon as possible, refit the standard tire instead of the space-saver wheel, remove the snow chains, if possible, check correct load distribution and repeat the RESET procedure by driving on a clean, tarmacked road. If the indications persist, contact an authorized dealer.

**OCCUPANT RESTRAINT SYSTEMS**

6

Some of the most important safety features in your vehicle are the restraint systems:

**OCCUPANT RESTRAINT SYSTEMS FEATURES**

- Seat Belt Systems
- Supplemental Restraint Systems (SRS) Air Bags
- Child Restraints

Some of the safety features described in this section may be standard equipment on some models, or may be optional equipment on others. If you are not sure, ask an authorized dealer.

## IMPORTANT SAFETY PRECAUTIONS

Please pay close attention to the information in this section. It tells you how to use your restraint system properly, to keep you and your passengers as safe as possible.

Here are some simple steps you can take to minimize the risk of harm from a deploying air bag:

1. Children 12 years old and under should always ride buckled up in the rear seat of a vehicle with a rear seat.
2. A child who is not big enough to wear the vehicle seat belt properly (Refer to "Child Restraints" in this section for further information) must be secured in the appropriate child restraint or belt-positioning booster seat in a rear seating position.
3. If a child from 2 to 12 years old (not in a rear-facing child restraint) must ride in the front passenger seat, move the seat as far back as possible and use the proper child restraint (Refer to "Child Restraints" in this section for further information).
4. Never allow children to slide the shoulder belt behind them or under their arm.
5. You should read the instructions provided with your child restraint to make sure that you are using it properly.
6. All occupants should always wear their lap and shoulder belts properly.

7. The driver and front passenger seats should be moved back as far as practical to allow the front air bags room to inflate.
8. Do not lean against the door or window. If your vehicle has side air bags, and deployment occurs, the side air bags will inflate forcefully into the space between occupants and the door and occupants could be injured.
9. If the air bag system in this vehicle needs to be modified to accommodate a disabled person, refer to the "Customer Assistance" section for customer service contact information.

### WARNING!

- Never place a rear-facing child restraint in front of an air bag. A deploying passenger front air bag can cause death or serious injury to a child 12 years or younger, including a child in a rear-facing child restraint.
- Never install a rear-facing child restraint in the front seat of a vehicle. Only use a rear-facing child restraint in the rear seat. If the vehicle does not have a rear seat, do not transport a rear-facing child restraint in that vehicle.

## SEAT BELT SYSTEMS

Buckle up even though you are an excellent driver, even on short trips. Someone on the road may be a poor driver and could cause a collision that includes you. This can happen far away from home or on your own street.

Research has shown that seat belts save lives, and they can reduce the seriousness of injuries in a collision. Some of the worst injuries happen when people are thrown from the vehicle. Seat belts reduce the possibility of ejection and the risk of injury caused by striking the inside of the vehicle. Everyone in a motor vehicle should be belted at all times.

## Enhanced Seat Belt Use Reminder System (BeltAlert)

### Driver and Passenger BeltAlert (if equipped)



BeltAlert is a feature intended to remind the driver and outboard front seat passenger (if equipped with outboard front passenger seat BeltAlert) to buckle their seat belts.

The Belt Alert feature is active whenever the ignition switch is in the ON/RUN position.

### Initial Indication

If the driver is unbuckled when the ignition switch is first in the ON/RUN position, a chime will signal for a few seconds. If the driver or outboard front seat passenger (if equipped with outboard front passenger seat BeltAlert) is unbuckled when the ignition switch is first in the ON/RUN position the Seat Belt Reminder Light will turn on and remain on until both outboard front seat belts are buckled. The outboard front passenger seat BeltAlert is not active when an outboard front passenger seat is unoccupied.

### BeltAlert Warning Sequence

The BeltAlert warning sequence is activated when the vehicle is moving above a specified vehicle speed range and the driver or outboard front seat passenger is unbuckled (if equipped with outboard front passenger

seat BeltAlert) (the outboard front passenger seat BeltAlert is not active when the outboard front passenger seat is unoccupied). The BeltAlert warning sequence starts by blinking the Seat Belt Reminder Light and sounding an intermittent chime. Once the BeltAlert warning sequence has completed, the Seat Belt Reminder Light will remain on until the seat belts are buckled. The BeltAlert warning sequence may repeat based on vehicle speed until the driver and occupied outboard front seat passenger seat belts are buckled. The driver should instruct all occupants to buckle their seat belts.

### Change of Status

If the driver or outboard front seat passenger (if equipped with outboard front passenger seat BeltAlert) unbuckles their seat belt while the vehicle is traveling, the BeltAlert warning sequence will begin until the seat belts are buckled again.

The outboard front passenger seat BeltAlert is not active when the outboard front passenger seat is unoccupied. BeltAlert may be triggered when an animal or other items are placed on the outboard front passenger seat or when the seat is folded flat (if equipped). It is recommended that pets be restrained in the rear seat (if equipped) in pet harnesses or pet carriers that are secured by seat belts, and cargo is properly stowed.

BeltAlert can be activated or deactivated by an authorized dealer. FCA US LLC does not recommend deactivating BeltAlert.

### NOTE:

If BeltAlert has been deactivated and the driver or outboard front seat passenger (if equipped with

outboard front passenger seat BeltAlert) is unbuckled the Seat Belt Reminder Light will turn on and remain on until the driver and outboard front seat passenger seat belts are buckled.

## Lap/Shoulder Belts

All seating positions in your vehicle are equipped with lap/shoulder belts.

The seat belt webbing retractor will lock only during very sudden stops or collisions. This feature allows the shoulder part of the seat belt to move freely with you under normal conditions. However, in a collision the seat belt will lock and reduce your risk of striking the inside of the vehicle or being thrown out of the vehicle.

### WARNING!

- Relying on the air bags alone could lead to more severe injuries in a collision. The air bags work with your seat belt to restrain you properly. In some collisions, the air bags won't deploy at all. Always wear your seat belt even though you have air bags.
- In a collision, you and your passengers can suffer much greater injuries if you are not properly buckled up. You can strike the interior of your vehicle or other passengers, or you can be thrown out of the vehicle. Always be sure you and others in your vehicle are buckled up properly.
- It is dangerous to ride in a cargo area, inside or outside of a vehicle. In a collision, people riding in these areas are more likely to be seriously injured or killed.

*(Continued)*

### WARNING!

- Do not allow people to ride in any area of your vehicle that is not equipped with seats and seat belts.
- Be sure everyone in your vehicle is in a seat and using a seat belt properly. Occupants, including the driver, should always wear their seat belts whether or not an air bag is also provided at their seating position to minimize the risk of severe injury or death in the event of a crash.
- Wearing your seat belt incorrectly could make your injuries in a collision much worse. You might suffer internal injuries, or you could even slide out of the seat belt. Follow these instructions to wear your seat belt safely and to keep your passengers safe, too.
- Two people should never be belted into a single seat belt. People belted together can crash into one another in a collision, hurting one another badly. Never use a lap/shoulder belt or a lap belt for more than one person, no matter what their size.

### WARNING!

- A lap belt worn too high can increase the risk of injury in a collision. The seat belt forces won't be at the strong hip and pelvic bones, but across your abdomen. Always wear the lap part of your seat belt as low as possible and keep it snug.

*(Continued)*

**WARNING!**

- A twisted seat belt may not protect you properly. In a collision, it could even cut into you. Be sure the seat belt is flat against your body, without twists. If you can't straighten a seat belt in your vehicle, take it to an authorized dealer immediately and have it fixed.
- A seat belt that is buckled into the wrong buckle will not protect you properly. The lap portion could ride too high on your body, possibly causing internal injuries. Always buckle your seat belt into the buckle nearest you.
- A seat belt that is too loose will not protect you properly. In a sudden stop, you could move too far forward, increasing the possibility of injury. Wear your seat belt snugly.
- A seat belt that is worn under your arm is dangerous. Your body could strike the inside surfaces of the vehicle in a collision, increasing head and neck injury. A seat belt worn under the arm can cause internal injuries. Ribs aren't as strong as shoulder bones. Wear the seat belt over your shoulder so that your strongest bones will take the force in a collision.
- A shoulder belt placed behind you will not protect you from injury during a collision. You are more likely to hit your head in a collision if you do not wear your shoulder belt. The lap and shoulder belt are meant to be used together.
- A frayed or torn seat belt could rip apart in a collision and leave you with no protection. Inspect

*(Continued)***WARNING!**

the seat belt system periodically, checking for cuts, frays, or loose parts. Damaged parts must be replaced immediately. Do not disassemble or modify the seat belt system. If your vehicle is involved in a collision, or if you have questions regarding seat belt or retractor conditions, take your vehicle to an authorized FCA dealer or authorized FCA Certified Collision Care Program facility for inspection.

**Lap/Shoulder Belt Operating Instructions**

1. Enter the vehicle and close the door. Sit back and adjust the seat.
2. The seat belt latch plate is above the back of the front seat, and next to your arm in the rear seat (for vehicles equipped with a rear seat). Grasp the latch plate and pull out the seat belt. Slide the latch plate up the webbing as far as necessary to allow the seat belt to go around your lap.

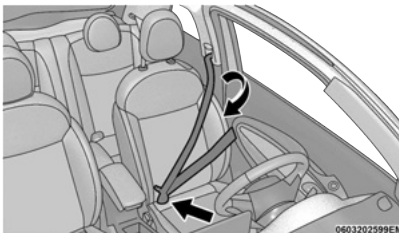
**Pulling Out The Latch Plate**

3. When the seat belt is long enough to fit, insert the latch plate into the buckle until you hear a "click."

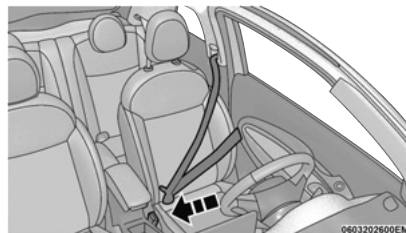
**Inserting Latch Plate Into Buckle**

4. Position the lap belt so that it is snug and lies low across your hips, below your abdomen. To remove slack in the lap belt portion, pull up on the shoulder belt. To loosen the lap belt if it is too tight, tilt the latch plate and pull on the lap belt. A snug seat belt reduces the risk of sliding under the seat belt in a collision.

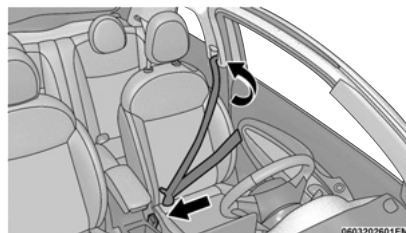
**Positioning The Lap Belt**

- Position the shoulder belt across the shoulder and chest with minimal, if any slack so that it is comfortable and not resting on your neck. The retractor will withdraw any slack in the shoulder belt.
- To release the seat belt, push the red button on the buckle. The seat belt will automatically retract to its stowed position. If necessary, slide the latch plate down the webbing to allow the seat belt to retract fully.

### Lap/Shoulder Belt Untwisting Procedure

Use the following procedure to untwist a twisted lap/shoulder belt.

- Position the latch plate as close as possible to the anchor point.
- At about 6 to 12 inches (15 to 30 cm) above the latch plate, grasp and twist the seat belt webbing 180 degrees to create a fold that begins immediately above the latch plate.
- Slide the latch plate upward over the folded webbing. The folded webbing must enter the slot at the top of the latch plate.
- Continue to slide the latch plate up until it clears the folded webbing and the seat belt is no longer twisted.

### Seat Belt Extender

If a seat belt is not long enough to fit properly, even when the webbing is fully extended and the adjustable upper shoulder belt anchorage (if equipped) is in its lowest position, an authorized dealer can provide you with a Seat Belt Extender. The Seat Belt Extender should be used only if the existing seat belt is not long enough. When the Seat Belt Extender is not required for a different occupant, it must be removed.

#### WARNING!

- ONLY use a Seat Belt Extender if it is physically required in order to properly fit the original seat belt system. DO NOT USE the Seat Belt Extender if, when worn, the distance between the front edge of the Seat Belt Extender buckle and the center of the occupant's body is LESS than 6 inches.
- Using a Seat Belt Extender when not needed can increase the risk of serious injury or death in a collision. Only use the Seat Belt Extender when the lap belt is not long enough and only use in the recommended seating positions. Remove and store the Seat Belt Extender when not needed.

### Seat Belts And Pregnant Women

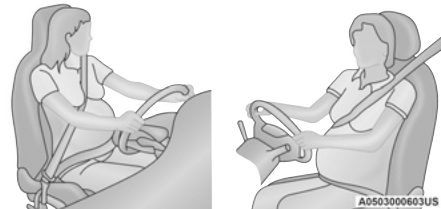

#### Seat Belts And Pregnant Women

Seat belts must be worn by all occupants including pregnant women: the risk of injury in the event of an accident is reduced for the mother and the unborn child if they are wearing a seat belt.

Position the lap belt snug and low below the abdomen and across the strong bones of the hips. Place the shoulder belt across the chest and away from the neck. Never place the shoulder belt behind the back or under the arm.

#### Seat Belt Pretensioner

The front outboard seat belt system is equipped with pretensioning devices that are designed to remove slack from the seat belt in the event of a collision. These devices may improve the performance of the seat belt by removing slack from the seat belt early in a collision. Pretensioners work for all size occupants, including those in child restraints.

**NOTE:**

These devices are not a substitute for proper seat belt placement by the occupant. The seat belt still must be worn snugly and positioned properly.

The pretensioners are triggered by the Occupant Restraint Controller (ORC). Like the air bags, the pretensioners are single use items. A deployed pretensioner or a deployed air bag must be replaced immediately.

## Energy Management Feature

The front outboard seat belt system is equipped with an Energy Management feature that may help further reduce the risk of injury in the event of a collision. The seat belt system has a retractor assembly that is designed to release webbing in a controlled manner.

## Switchable Automatic Locking Retractor (ALR)

The seat belts in the passenger seating positions are equipped with a Switchable Automatic Locking Retractor (ALR) which is used to secure a child restraint system. For additional information, refer to "Installing Child Restraints Using The Vehicle Seat Belt" under the "Child Restraints" section of this manual.

The figure below illustrates the locking feature for each seating position.

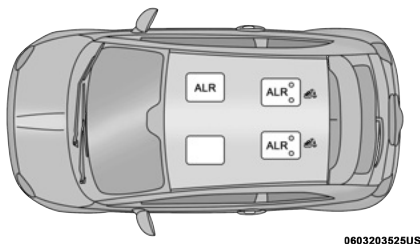

0603203525US

### ALR — Switchable Automatic Locking Retractor

If the passenger seating position is equipped with an ALR and is being used for normal usage, only pull the seat belt webbing out far enough to comfortably wrap around the occupant's mid-section so as to not activate the ALR. If the ALR is activated, you will hear a clicking sound as the seat belt retracts. Allow the webbing to retract completely in this case and then carefully pull out only the amount of webbing necessary to comfortably wrap around the occupant's mid-section. Slide the latch plate into the buckle until you hear a "click."

In Automatic Locking Mode, the shoulder belt is automatically pre-locked. The seat belt will still retract to remove any slack in the shoulder belt. Use the Automatic Locking Mode anytime a child restraint is installed in a seating position that has a seat belt with this feature. Children 12 years old and under should always be properly restrained in the rear seat of a vehicle with a rear seat.

### WARNING!

- Never place a rear-facing child restraint in front of an air bag. A deploying passenger front air bag can cause death or serious injury to a child 12 years or younger, including a child in a rear-facing child restraint.
- Never install a rear-facing child restraint in the front seat of a vehicle. Only use a rear-facing child restraint in the rear seat. If the vehicle does not have a rear seat, do not transport a rear-facing child restraint in that vehicle.

### How To Engage The Automatic Locking Mode

1. Buckle the combination lap and shoulder belt.
2. Grasp the shoulder portion and pull downward until the entire seat belt is extracted.
3. Allow the seat belt to retract. As the seat belt retracts, you will hear a clicking sound. This indicates the seat belt is now in the Automatic Locking Mode.

### How To Disengage The Automatic Locking Mode

Unbuckle the combination lap/shoulder belt and allow it to retract completely to disengage the Automatic Locking Mode and activate the vehicle sensitive (emergency) locking mode.

**WARNING!**

- The seat belt assembly must be replaced if the switchable Automatic Locking Retractor (ALR) feature or any other seat belt function is not working properly when checked according to the procedures in the Service Manual.
- Failure to replace the seat belt assembly could increase the risk of injury in collisions.
- Do not use the Automatic Locking Mode to restrain occupants who are wearing the seat belt or children who are using booster seats. The locked mode is only used to install rear-facing or forward-facing child restraints that have a harness for restraining the child.

**SUPPLEMENTAL RESTRAINT SYSTEMS (SRS)**

Some of the safety features described in this section may be standard equipment on some models, or may be optional equipment on others. If you are not sure, ask an authorized dealer.

The air bag system must be ready to protect you in a collision. The Occupant Restraint Controller (ORC) monitors the internal circuits and interconnecting wiring associated with the electrical Air Bag System Components. Your vehicle may be equipped with the following Air Bag System Components:

**Air Bag System Components**

- Occupant Restraint Controller (ORC)
- Air Bag Warning Light 

- Steering Wheel and Column
- Instrument Panel
- Driver Knee Impact Bolster
- Driver and Front Passenger Air Bags
- Seat Belt Buckle Switch
- Supplemental Side Air Bags
- Supplemental Knee Air Bags
- Front and Side Impact Sensors
- Seat Belt Pretensioners
- Seat Track Position Sensors

**Air Bag Warning Light**

The ORC monitors the readiness of the electronic parts of the air bag system whenever the ignition switch is in the ON/RUN position. If the ignition switch is in the OFF position the air bag system is not on and the air bags will not inflate.

The ORC contains a backup power supply system that may deploy the air bag system even if the battery loses power or it becomes disconnected prior to deployment.

The ORC turns on the Air Bag Warning Light in the instrument panel for approximately four to eight seconds for a self-check when the ignition switch is in the ON/RUN position. After the self-check, the Air Bag Warning Light will turn off. If the ORC detects a malfunction in any part of the system, it turns on the Air Bag Warning Light, either momentarily or continuously. A single chime will sound to alert you if the light comes on again after initial startup.

The ORC also includes diagnostics that will illuminate the instrument panel Air Bag Warning Light if a malfunction is detected that could affect the air bag system. The diagnostics also record the nature of the malfunction. While the air bag system is designed to be maintenance free, if any of the following occurs, have an authorized dealer service the air bag system immediately.

- The Air Bag Warning Light does not come on during the four to eight seconds when the ignition switch is first in the ON/RUN position.
- The Air Bag Warning Light remains on after the four to eight-second interval.
- The Air Bag Warning Light comes on intermittently or remains on while driving.

**NOTE:**

If the speedometer, tachometer, or any engine related gauges are not working, the Occupant Restraint Controller (ORC) may also be disabled. In this condition the air bags may not be ready to inflate for your protection. Have an authorized dealer service the air bag system immediately.

**WARNING!**

Ignoring the Air Bag Warning Light in your instrument panel could mean you won't have the air bag system to protect you in a collision. If the light does not come on as a bulb check when the ignition is first turned on, stays on after you start the vehicle, or if it comes on as you drive, have an authorized dealer service the air bag system immediately.

## Front Air Bags

This vehicle has front air bags and lap/shoulder belts for both the driver and front passenger. The front air bags are a supplement to the seat belt restraint systems. The driver front air bag is mounted in the center of the steering wheel. The passenger front air bag is mounted in the instrument panel, above the glove compartment. The words “SRS AIRBAG” or “AIRBAG” are embossed on the air bag covers.

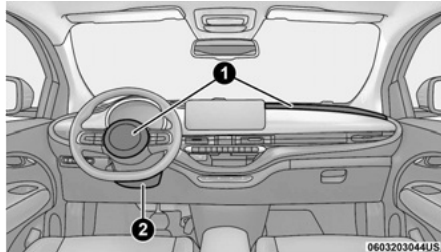

### Front Air Bag/Knee Impact Bolster Locations

- 1 — Driver And Passenger Front Air Bags  
2 — Driver Knee Impact Bolster/Supplemental Driver Knee Air Bag

#### WARNING!

- Being too close to the steering wheel or instrument panel during front air bag deployment could cause serious injury, including death. Air bags need room to inflate. Sit back, comfortably

*(Continued)*

#### WARNING!

extending your arms to reach the steering wheel or instrument panel.

- Never place a rear-facing child restraint in front of an air bag. A deploying passenger front air bag can cause death or serious injury to a child 12 years or younger, including a child in a rear-facing child restraint.
- Never install a rear-facing child restraint in the front seat of a vehicle. Only use a rear-facing child restraint in the rear seat. If the vehicle does not have a rear seat, do not transport a rear-facing child restraint in that vehicle.

## Driver And Passenger Front Air Bag Features

The Advanced Front Air Bag system has multistage driver and front passenger air bags. This system provides output appropriate to the severity and type of collision as determined by the Occupant Restraint Controller (ORC), which may receive information from the front impact sensors (if equipped) or other system components.

The first stage inflator is triggered immediately during an impact that requires air bag deployment. A low energy output is used in less severe collisions. A higher energy output is used for more severe collisions.

This vehicle may be equipped with a driver and/or front passenger seat belt buckle switch that detects whether the driver or front passenger seat belt is buckled. The seat belt buckle switch may adjust the inflation rate of the Advanced Front Air Bags.

This vehicle may be equipped with driver and/or front passenger seat track position sensors that may adjust the inflation rate of the Advanced Front Air Bags based upon seat position.

#### WARNING!

- No objects should be placed over or near the air bag on the instrument panel or steering wheel because any such objects could cause harm if the vehicle is in a collision severe enough to cause the air bag to inflate.
- Do not put anything on or around the air bag covers or attempt to open them manually. You may damage the air bags and you could be injured because the air bags may no longer be functional. The protective covers for the air bag cushions are designed to open only when the air bags are inflating.
- Relying on the air bags alone could lead to more severe injuries in a collision. The air bags work with your seat belt to restrain you properly. In some collisions, air bags won't deploy at all. Always wear your seat belts even though you have air bags.

## Front Air Bag Operation

Front Air Bags are designed to provide additional protection by supplementing the seat belts. Front air bags are not expected to reduce the risk of injury in rear, side, or rollover collisions. The front air bags will not deploy in all frontal collisions, including some that may produce substantial vehicle damage — for



example, some pole collisions, truck underrides, and angle offset collisions.

On the other hand, depending on the type and location of impact, front air bags may deploy in crashes with little vehicle front-end damage but that produce a severe initial deceleration.

Because air bag sensors measure vehicle deceleration over time, vehicle speed and damage by themselves are not good indicators of whether or not an air bag should have deployed.

Seat belts are necessary for your protection in all collisions, and also are needed to help keep you in position, away from an inflating air bag.

When the ORC detects a collision requiring the front air bags, it signals the inflator units. A large quantity of non-toxic gas is generated to inflate the front air bags.

The steering wheel hub trim cover and the upper passenger side of the instrument panel separate and fold out of the way as the air bags inflate to their full size. The front air bags fully inflate in less time than it takes to blink your eyes. The front air bags then quickly deflate while helping to restrain the driver and front passenger.

## Knee Impact Bolsters

The Knee Impact Bolsters help protect the knees of the driver and front passenger, and position the front occupants for improved interaction with the front air bags.

### WARNING!

- Do not drill, cut, or tamper with the knee impact bolsters in any way.
- Do not mount any accessories to the knee impact bolsters such as alarm lights, stereos, citizen band radios, etc.

## Supplemental Driver Knee Air Bag

This vehicle is equipped with a Supplemental Driver Knee Air Bag mounted in the instrument panel below the steering column. The Supplemental Driver Knee Air Bag provides enhanced protection during a frontal impact by working together with the seat belts, pretensioners, and front air bags.

## Supplemental Side Air Bags

### Supplemental Seat-Mounted Side Air Bags (SABs)

This vehicle is equipped with Supplemental Seat-Mounted Side Air Bags (SABs).

Supplemental Seat-Mounted Side Air Bags (SABs) are located in the outboard side of the front seats. The SABs are marked with "SRS AIRBAG" or "AIRBAG" on a label or on the seat trim on the outboard side of the seats.

The SABs may help to reduce the risk of occupant injury during certain side impacts, in addition to the injury reduction potential provided by the seat belts and body structure.

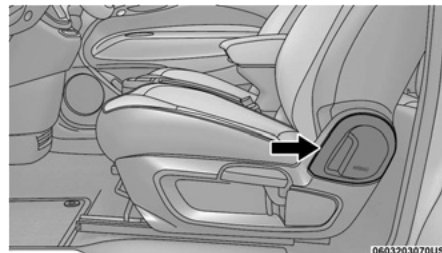

### Front Supplemental Seat-Mounted Side Air Bag

When the SAB deploys, it opens the seam on the outboard side of the seatback's trim cover. The inflating SAB deploys through the seat seam into the space between the occupant and the door. The SAB moves at a very high speed and with such a high force that it could injure occupants if they are not seated properly, or if items are positioned in the area where the SAB inflates. Children are at an even greater risk of injury from a deploying air bag.

6

### WARNING!

Do not use accessory seat covers or place objects between you and the Side Air Bags; the performance could be adversely affected and/or objects could be pushed into you, causing serious injury.

### Supplemental Side Air Bag Inflatable Curtains (SABICs)

This vehicle is equipped with Supplemental Side Air Bag Inflatable Curtains (SABICs).

Supplemental Side Air Bag Inflatable Curtains (SABICs) are located above the side windows. The trim covering the SABICs is labeled “SRS AIRBAG” or “AIRBAG.”



0601203250US

### Supplemental Side Air Bag Inflatable Curtain (SABIC) Label Location

SABICs may help reduce the risk of head and other injuries to front and rear seat outboard occupants in certain side impacts, in addition to the injury reduction potential provided by the seat belts and body structure.

The SABIC deploys downward, covering the side windows. An inflating SABIC pushes the outside edge of the headliner out of the way and covers the window. The SABICs inflate with enough force to injure occupants if they are not belted and seated properly, or if items are positioned in the area where the SABICs inflate. Children are at an even greater risk of injury from a deploying air bag.

The SABICs may help reduce the risk of partial or complete ejection of vehicle occupants through side windows in certain side impact events.

### WARNING!

- Do not mount equipment, or stack luggage or other cargo up high enough to block the deployment of the SABICs. The trim covering above the side windows where the SABIC and its deployment path are located should remain free from any obstructions.
- In order for the SABICs to work as intended, do not install any accessory items in your vehicle which could alter the roof. Do not add an aftermarket sunroof to your vehicle. Do not add roof racks that require permanent attachments (bolts or screws) for installation on the vehicle roof. Do not drill into the roof of the vehicle for any reason.

### Side Impacts

The Side Air Bags are designed to activate in certain side impacts. The Occupant Restraint Controller (ORC) determines whether the deployment of the Side Air Bags in a particular impact event is appropriate, based on the severity and type of collision. The side impact sensors aid the ORC in determining the appropriate response to impact events. The system is calibrated to deploy the Side Air Bags on the impact side of the vehicle during impacts that require Side Air Bag occupant protection. In side impacts, the Side Air Bags deploy independently; a left side impact deploys the left Side Air Bags only and a right-side impact deploys the right Side Air Bags only. Vehicle damage by itself is not a good indicator of whether or not Side Air Bags should have deployed.

The Side Air Bags will not deploy in all side collisions, including some collisions at certain angles, or some

side collisions that do not impact the area of the passenger compartment. The Side Air Bags may deploy during angled or offset frontal collisions where the front air bags deploy.

Side Air Bags are a supplement to the seat belt restraint system. Side Air Bags deploy in less time than it takes to blink your eyes.

### WARNING!

- Occupants, including children, who are up against or very close to Side Air Bags can be seriously injured or killed. Occupants, including children, should never lean on or sleep against the door, side windows, or area where the side air bags inflate, even if they are in an infant or child restraint.
- Seat belts (and child restraints where appropriate) are necessary for your protection in all collisions. They also help keep you in position, away from an inflating Side Air Bag. To get the best protection from the Side Air Bags, occupants must wear their seat belts properly and sit upright with their backs against the seats. Children must be properly restrained in a child restraint or booster seat that is appropriate for the size of the child.

### WARNING!

- Side Air Bags need room to inflate. Do not lean against the door or window. Sit upright in the center of the seat.

*(Continued)*

**WARNING!**

- Being too close to the Side Air Bags during deployment could cause you to be severely injured or killed.
- Relying on the Side Air Bags alone could lead to more severe injuries in a collision. The Side Air Bags work with your seat belt to restrain you properly. In some collisions, Side Air Bags won't deploy at all. Always wear your seat belt even though you have Side Air Bags.

**NOTE:**

Air bag covers may not be obvious in the interior trim, but they will open during air bag deployment.

**Rollover Events**

Side Air Bags and seat belt pretensioners are designed to activate in certain rollover events. The Occupant Restraint Controller (ORC) determines whether deployment in a particular rollover event is appropriate, based on the severity and type of collision. Vehicle damage by itself is not a good indicator of whether or not Side Air Bags and seat belt pretensioners should have deployed.

The Side Air Bags and seat belt pretensioners will not deploy in all rollover events. The rollover sensing system determines if a rollover event may be in progress and whether deployment is appropriate. In the event the vehicle experiences a rollover or near rollover event, and deployment is appropriate, the rollover sensing system will deploy the side air bags and seat belt pretensioners on both sides of the vehicle.

The SABICs may help reduce the risk of partial or complete ejection of vehicle occupants through side windows in certain rollover or side impact events.

**Air Bag System Components****NOTE:**

The Occupant Restraint Controller (ORC) monitors the internal circuits and interconnecting wiring associated with electrical Air Bag System Components listed below:

- Occupant Restraint Controller (ORC)
- Air Bag Warning Light 
- Steering Wheel and Column
- Instrument Panel
- Driver Knee Impact Bolster
- Driver and Front Passenger Air Bags
- Seat Belt Buckle Switch
- Supplemental Side Air Bags
- Supplemental Knee Air Bags
- Front and Side Impact Sensors
- Seat Belt Pretensioners
- Seat Track Position Sensors

**If A Deployment Occurs**

The front air bags are designed to deflate immediately after deployment.

**NOTE:**

Front and/or side air bags will not deploy in all collisions. This does not mean something is wrong with the air bag system.

If you do have a collision which deploys the air bags, any or all of the following may occur:

- The air bag material may sometimes cause abrasions and/or skin reddening to the occupants as the air bags deploy and unfold. The abrasions are similar to friction rope burns or those you might get sliding along a carpet or gymnasium floor. They are not caused by contact with chemicals. They are not permanent and normally heal quickly. However, if you haven't healed significantly within a few days, or if you have any blistering, see your doctor immediately.
- As the air bags deflate, you may see some smoke-like particles. The particles are a normal by-product of the process that generates the non-toxic gas used for air bag inflation. These airborne particles may irritate the skin, eyes, nose, or throat. If you have skin or eye irritation, rinse the area with cool water. For nose or throat irritation, move to fresh air. If the irritation continues, see your doctor. If these particles settle on your clothing, follow the garment manufacturer's instructions for cleaning.

Do not drive your vehicle after the air bags have deployed. If you are involved in another collision, the air bags will not be in place to protect you.

**WARNING!**

Deployed air bags and seat belt pretensioners cannot protect you in another collision. Have the air bags, seat belt pretensioners, and the seat belt retractor assemblies replaced by an authorized dealer immediately. Also, have the Occupant Restraint Controller System serviced as well.

**NOTE:**

- Air bag covers may not be obvious in the interior trim, but they will open during air bag deployment.
- After any collision, the vehicle should be taken to an authorized dealer immediately.

## Enhanced Accident Response System

In the event of an impact, if the communication network remains intact, and the power remains intact, depending on the nature of the event, the ORC will determine whether to have the Enhanced Accident Response System perform the following functions:

- Cut off battery power to the electric motor.
- Flash hazard lights as long as the battery has power.
- Turn on the interior lights, which remain on as long as the battery has power or for 15 minutes from the intervention of the Enhanced Accident Response System.
- Unlock the power door locks.

Your vehicle may also be designed to perform any of these other functions in response to the Enhanced Accident Response System:

- Turn off the HVAC Blower Motor, Close the HVAC Circulation Door
- Cut off battery power to the:
  - Electric Motor
  - Electric power steering
  - Brake booster
  - Electric park brake
  - Automatic transmission gear selector
  - Horn
  - Front wiper

**NOTE:**

After an accident, remember to place the ignition in the OFF position to avoid draining the battery. Carefully check the vehicle before resetting the system and starting the engine. If there are no damage to the vehicle electrical devices (e.g. headlights) after an accident, reset the system by following the procedure described below. If you have any doubt, contact an authorized dealer.

## Enhanced Accident Response System Reset Procedure

After an event occurs requiring activation of the Enhanced Accident Response System, when the system is active, a "Service Electrical System" message will be displayed on the instrument cluster. The vehicle is not drivable in this state and must be towed to an authorized dealer immediately to be inspected and have the Enhanced Accident Response System reset.

## Maintaining Your Air Bag System

**WARNING!**

- Modifications to any part of the air bag system could cause it to fail when you need it. You could be injured if the air bag system is not there to protect you. Do not modify the components or wiring, including adding any kind of badges or stickers to the steering wheel hub trim cover or the upper passenger side of the instrument panel. Do not modify the front bumper, vehicle body structure, or add aftermarket side steps or running boards.
- It is dangerous to try to repair any part of the air bag system yourself. Be sure to tell anyone who works on your vehicle that it has an air bag system.
- Do not attempt to modify any part of your air bag system. The air bag may inflate accidentally or may not function properly if modifications are made. Take your vehicle to an authorized dealer for any air bag system service. If your seat, including your trim cover and cushion, needs to be serviced in any way (including removal or loosening/tightening of seat attachment bolts), take the vehicle to an authorized dealer. Only manufacturer approved seat accessories may be used. If it is necessary to modify the air bag system for persons with disabilities, contact an authorized dealer.

## Event Data Recorder (EDR)

This vehicle is equipped with an event data recorder (EDR). The main purpose of an EDR is to record, in certain crash or near crash-like situations, such as an air bag deployment or hitting a road obstacle, data that will assist in understanding how a vehicle's systems performed. The EDR is designed to record data related to vehicle dynamics and safety systems for a short period of time, typically 30 seconds or less. The EDR in this vehicle is designed to record such data as:

- How various systems in your vehicle were operating;
- Whether or not the driver and passenger safety belts were buckled/fastened;
- How far (if at all) the driver was depressing the accelerator and/or brake pedal; and,
- How fast the vehicle was traveling.

These data can help provide a better understanding of the circumstances in which crashes and injuries occur.

### NOTE:

EDR data are recorded by your vehicle only if a non-trivial crash situation occurs; no data are recorded by the EDR under normal driving conditions and no personal data (e.g., name, gender, age, and crash location) are recorded. However, other parties, such as

law enforcement, could combine the EDR data with the type of personally identifying data routinely acquired during a crash investigation.

To read data recorded by an EDR, special equipment is required, and access to the vehicle or the EDR is needed. In addition to the vehicle manufacturer, other parties, such as law enforcement, that have the special equipment, can read the information if they have access to the vehicle or the EDR.

## CHILD RESTRAINTS

Everyone in your vehicle needs to be buckled up at all times, including babies and children. Every state in the United States, and every Canadian province, requires that small children ride in proper restraint systems. This is the law, and you can be prosecuted for ignoring it.

Children 12 years or younger should ride properly buckled up in a rear seat, if available. According to crash statistics, children are safer when properly restrained in the rear seats rather than in the front.

### WARNING!

In a collision, an unrestrained child can become a projectile inside the vehicle. The force required to hold even an infant on your lap could become so great that you could not hold the child, no matter

*(Continued)*

### WARNING!

how strong you are. The child and others could be badly injured or killed. Any child riding in your vehicle should be in a proper restraint for the child's size.

There are different sizes and types of restraints for children from newborn size to the child almost large enough for an adult safety belt. Always check the child seat Owner's Manual to make sure you have the correct seat for your child. Carefully read and follow all the instructions and warnings in the child restraint Owner's Manual and on all the labels attached to the child restraint.

Before buying any restraint system, make sure that it has a label certifying that it meets all applicable Safety Standards. You should also make sure that you can install it in the vehicle where you will use it.

### NOTE:

- For additional information, refer to <http://www.nhtsa.gov/parents-and-caregivers> or call 1-888-327-4236.
- Canadian residents should refer to Transport Canada's website for additional information: <http://www.tc.gc.ca/eng/motorvehiclesafety/safedrivers-childsafety-index-53.htm>.

## Summary Of Recommendations For Restraining Children In Vehicles

	<b>Child Size, Height, Weight Or Age</b>	<b>Recommended Type Of Child Restraint</b>
Infants and Toddlers	Children who are two years old or younger and who have not reached the height or weight limits of their child restraint	Either an Infant Carrier or a Convertible Child Restraint, facing rearward in a rear seat of the vehicle
Small Children	Children who are at least two years old or who have outgrown the height or weight limit of their rear-facing child restraint	Forward-Facing Child Restraint with a five-point Harness, facing forward in a rear seat of the vehicle
Larger Children	Children who have outgrown their forward-facing child restraint, but are too small to properly fit the vehicle's seat belt	Belt Positioning Booster Seat and the vehicle seat belt, seated in a rear seat of the vehicle
Children Too Large for Child Restraints	Children 12 years old or younger, who have outgrown the height or weight limit of their booster seat	Vehicle Seat Belt, seated in a rear seat of the vehicle

## Infant And Child Restraints

Safety experts recommend that children ride rear-facing in the vehicle until they are two years old or until they reach either the height or weight limit of their rear-facing child restraint. Two types of child restraints can be used rear-facing: infant carriers and convertible child seats.

The infant carrier is only used rear-facing in the vehicle. It is recommended for children from birth until they reach the weight or height limit of the infant carrier. Convertible child seats can be used either rear-facing or forward-facing in the vehicle. Convertible child seats often have a higher weight limit in the rear-facing direction than infant carriers do, so they can be used rear-facing by children who have outgrown their infant carrier but are still less than at least two years old. Children should remain rear-facing until they reach the highest weight or height allowed by their convertible child seat.

### WARNING!

- Never place a rear-facing child restraint in front of an air bag. A deploying passenger front air bag can cause death or serious injury to a child 12 years or younger, including a child in a rear-facing child restraint.
- Never install a rear-facing child restraint in the front seat of a vehicle. Only use a rear-facing child restraint in the rear seat. If the vehicle does not have a rear seat, do not transport a rear-facing child restraint in that vehicle.

## Older Children And Child Restraints

Children who are two years old or who have outgrown their rear-facing convertible child seat can ride forward-facing in the vehicle. Forward-facing child seats and convertible child seats used in the forward-facing direction are for children who are over two years old or who have outgrown the rear-facing weight or height limit of their rear-facing convertible child seat. Children should remain in a forward-facing child seat with a harness for as long as possible, up to the highest weight or height allowed by the child seat.

All children whose weight or height is above the forward-facing limit for the child seat should use a belt-positioning booster seat until the vehicle's seat belts fit properly. If the child cannot sit with knees bent over the vehicle's seat cushion while the child's back is against the seatback, they should use a belt-positioning booster seat. The child and belt-positioning booster seat are held in the vehicle by the seat belt.

### WARNING!

- Improper installation can lead to failure of an infant or child restraint. It could come loose in a collision. The child could be badly injured or killed. Follow the child restraint manufacturer's directions exactly when installing an infant or child restraint.
- After a child restraint is installed in the vehicle, do not move the vehicle seat forward or rearward because it can loosen the child restraint attachments. Remove the child restraint before adjusting the vehicle seat position. When the

*(Continued)*

### WARNING!

vehicle seat has been adjusted, reinstall the child restraint.

- When your child restraint is not in use, secure it in the vehicle with the seat belt or LATCH anchorages, or remove it from the vehicle. Do not leave it loose in the vehicle. In a sudden stop or accident, it could strike the occupants or seatbacks and cause serious personal injury.

## Children Too Large For Booster Seats

Children who are large enough to wear the shoulder belt comfortably, and whose legs are long enough to bend over the front of the seat when their back is against the seatback, should use the seat belt in a rear seat. Use this simple 5-step test to decide whether the child can use the vehicle's seat belt alone:

1. Can the child sit all the way back against the back of the vehicle seat?
2. Do the child's knees bend comfortably over the front of the vehicle seat – while the child is still sitting all the way back?
3. Does the shoulder belt cross the child's shoulder between the neck and arm?
4. Is the lap part of the belt as low as possible, touching the child's thighs and not the stomach?
5. Can the child stay seated like this for the whole trip?

If the answer to any of these questions was “no,” then the child still needs to use a booster seat in this vehicle. If the child is using the lap/shoulder belt, check seat belt fit periodically and make sure the seat belt buckle is latched. A child’s squirming or slouching can move the belt out of position. If the shoulder belt

contacts the face or neck, move the child closer to the center of the vehicle, or use a booster seat to position the seat belt on the child correctly.

**WARNING!**

Never allow a child to put the shoulder belt under an arm or behind their back. In a crash, the shoulder

*(Continued)*

**WARNING!**

belt will not protect a child properly, which may result in serious injury or death. A child must always wear both the lap and shoulder portions of the seat belt correctly.

### Recommendations For Attaching Child Restraints

Restraint Type	Combined Weight of the Child + Child Restraint	Use Any Attachment Method Shown With An “X” Below			
		LATCH – Lower Anchors Only	Seat Belt Only	LATCH – Lower Anchors + Top Tether Anchor	Seat Belt + Top Tether Anchor
Rear-Facing Child Restraint	Up to 65 lbs (29.5 kg)	X	X		
Rear-Facing Child Restraint	More than 65 lbs (29.5 kg)		X		
Forward-Facing Child Restraint	Up to 65 lbs (29.5 kg)			X	X
Forward-Facing Child Restraint	More than 65 lbs (29.5 kg)				X



## Lower Anchors And Tethers For Children (LATCH) Restraint System



022668173

LATCH Label

Your vehicle is equipped with the child restraint anchorage system called LATCH, which stands for Lower Anchors and Tethers for Children. The LATCH system has three vehicle anchor points for installing LATCH-equipped child seats. There are two lower anchorages located at the back of the seat cushion where it meets the seatback and one top tether anchorage located behind the seating position. These anchorages are used to install LATCH-equipped child seats without using the vehicle's seat belts. Some seating positions may have a top tether anchorage but no lower anchorages. In these seating positions, the seat belt must be used with the top tether anchorage to install the child restraint. Please see the following table for more information.

## LATCH Positions For Installing Child Restraints In This Vehicle

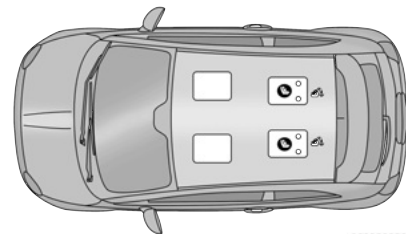

0603203269US

LATCH Positions

 Lower Anchorage Symbol (2 Anchorages Per Seating Position)

 Top Tether Anchorage Symbol

Frequently Asked Questions About Installing Child Restraints With LATCH		
What is the weight limit (child's weight + weight of the child restraint) for using the LATCH anchorage system to attach the child restraint?	65 lbs (29.5 kg)	Use the LATCH anchorage system until the combined weight of the child and the child restraint is 65 lbs (29.5 kg). Use the seat belt and tether anchor instead of the LATCH anchorage system once the combined weight is more than 65 lbs (29.5 kg).
Can the LATCH anchorages and the seat belt be used together to attach a rear-facing or forward-facing child restraint?	No	Do not use the seat belt when you use the LATCH anchorage system to attach a rear-facing or forward-facing child restraint.  Booster seats may be attached to the LATCH anchorages if allowed by the booster seat manufacturer. See your booster seat owner's manual for more information.
Can two child restraints be attached using a common lower LATCH anchorage?	No	Never "share" a LATCH anchorage with two or more child restraints. If the center position does not have dedicated LATCH lower anchorages, use the seat belt to install a child seat in the center position next to a child seat using the LATCH anchorages in an outboard position.
Can the rear-facing child restraint touch the back of the front passenger seat?	Yes	The child seat may touch the back of the front passenger seat if the child restraint manufacturer also allows contact. See your child restraint owner's manual for more information.
Can the rear head restraints be removed?	Yes	The head restraints can be removed in each seating position if they interfere with the installation of the child restraint.  Refer to "Head Restraints" in "Getting To Know Your Vehicle" for further information.

## Locating The LATCH Anchorages



The lower anchorages are round bars that are found at the rear of the seat cushion where it meets the seatback, below the anchorage symbols on the seatback. They

are just visible when you lean into the rear seat to

install the child restraint. You will easily feel them if you run your finger along the gap between the seatback and seat cushion.

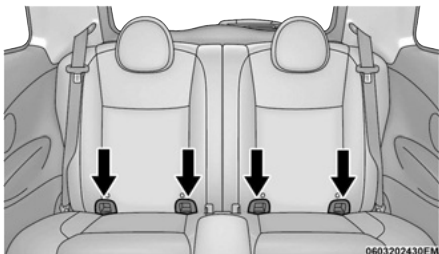

### LATCH Lower Anchorages

### Locating The Upper Tether Anchorages



There are tether strap anchorages behind each rear seating position located on the back of the seat.

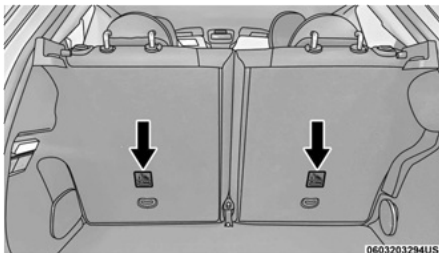

### Rear Seat Tether Strap Mounting

LATCH-compatible child restraint systems will be equipped with a rigid bar or a flexible strap on each side. Each will have a hook or connector to

attach to the lower anchorage and a way to tighten the connection to the anchorage. Forward-facing child restraints and some rear-facing child restraints will also be equipped with a tether strap. The tether strap will have a hook at the end to attach to the top tether anchorage and a way to tighten the strap after it is attached to the anchorage.

### Center Seat LATCH

#### WARNING!

This vehicle does not have a center seating position. Do not use the center lower LATCH anchorages to install a child seat in the center of the back seat.

**Always follow the directions of the child restraint manufacturer when installing your child restraint. Not all child restraint systems will be installed as described here.**

### To Install A LATCH-Compatible Child Restraint

If the selected seating position has a Switchable Automatic Locking Retractor (ALR) seat belt, stow the seat belt, following the instructions below. See the section "Installing Child Restraints Using the Vehicle Seat Belt" to check what type of seat belt each seating position has.

1. Loosen the adjusters on the lower straps and on the tether strap of the child seat so that you can more easily attach the hooks or connectors to the vehicle anchorages.

2. Place the child seat between the lower anchorages for that seating position. For some second row seats, you may need to recline the seat and / or raise the head restraint (if adjustable) to get a better fit. If the rear seat can be moved forward and rearward in the vehicle, you may wish to move it to its rear-most position to make room for the child seat. You may also move the front seat forward to allow more room for the child seat.
3. Attach the lower hooks or connectors of the child restraint to the lower anchorages in the selected seating position.
4. If the child restraint has a tether strap, connect it to the top tether anchorage. See the section "Installing Child Restraints Using the Top Tether Anchorage" for directions to attach a tether anchor.
5. Tighten all of the straps as you push the child restraint rearward and downward into the seat. Remove slack in the straps according to the child restraint manufacturer's instructions.
6. Test that the child restraint is installed tightly by pulling back and forth on the child seat at the belt path. It should not move more than 1 inch (25.4 mm) in any direction.

### How To Stow An Unused Switchable-ALR (ALR) Seat Belt:

When using the LATCH attaching system to install a child restraint, stow all ALR seat belts that are not being used by other occupants or being used to secure

child restraints. An unused belt could injure a child if they play with it and accidentally lock the seat belt retractor. Before installing a child restraint using the LATCH system, buckle the seat belt behind the child restraint and out of the child's reach. If the buckled seat belt interferes with the child restraint installation, instead of buckling it behind the child restraint, route the seat belt through the child restraint belt path and then buckle it. Do not lock the seat belt. Remind all children in the vehicle that the seat belts are not toys and that they should not play with them.

**WARNING!**

- Improper installation of a child restraint to the LATCH anchorages can lead to failure of the restraint. The child could be badly injured or killed. Follow the child restraint manufacturer's directions exactly when installing an infant or child restraint.
- Child restraint anchorages are designed to withstand only those loads imposed by correctly-fitted child restraints. Under no circumstances are they to be used for adult seat belts, harnesses, or for attaching other items or equipment to the vehicle.

*(Continued)*

**WARNING!**

### Installing Child Restraints Using The Vehicle Seat Belt

Child restraint systems are designed to be secured in vehicle seats by lap belts or the lap belt portion of a lap/shoulder belt.

**WARNING!**

- Improper installation or failure to properly secure a child restraint can lead to failure of the restraint. The child could be badly injured or killed.
- Follow the child restraint manufacturer's directions exactly when installing an infant or child restraint.

The seat belts in the passenger seating positions are equipped with a Switchable Automatic Locking Retractor (ALR) that is designed to keep the lap portion of the seat belt tight around the child restraint so that it is not necessary to use a locking clip. The ALR retractor can be "switched" into a locked mode by pulling all of the webbing out of the retractor and then letting the webbing retract back into the retractor. If it is locked,

the ALR will make a clicking noise while the webbing is pulled back into the retractor.

Refer to the "Automatic Locking Mode" description in "Switchable Automatic Locking Retractors (ALR)" under "Occupant Restraint Systems" for additional information on ALR.

Please see the table below and the following sections for more information.

### Lap/Shoulder Belt Systems For Installing Child Restraints In This Vehicle

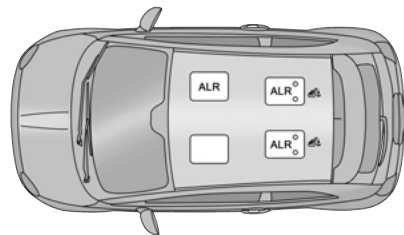

0603203525US

#### Automatic Locking Retractor (ALR) Locations

ALR = Switchable Automatic Locking Retractor

 Top Tether Anchorage Symbol

#### Frequently Asked Questions About Installing Child Restraints With Seat Belts

What is the weight limit (child's weight + weight of the child restraint) for using the Tether Anchor with the seat belt to attach a forward facing child restraint?	Weight limit of the Child Restraint	Always use the tether anchor when using the seat belt to install a forward facing child restraint, up to the recommended weight limit of the child restraint.
--	-------------------------------------	---

Can the rear-facing child restraint touch the back of the front passenger seat?	Yes	Contact between the front passenger seat and the child restraint is allowed, if the child restraint manufacturer also allows contact.
Can the rear head restraints be removed?	Yes	The head restraints can be removed in each seating position if they interfere with the installation of the child restraint.  Refer to “Head Restraints” in “Getting To Know Your Vehicle” for further information.
Can the buckle stalk be twisted to tighten the seat belt against the belt path of the child restraint?	No	Do not twist the buckle stalk in a seating position with an ALR retractor.

## Installing A Child Restraint With A Switchable Automatic Locking Retractor (ALR):

Child restraint systems are designed to be secured in vehicle seats by lap belts or the lap belt portion of a lap/shoulder belt.

### WARNING!

- Improper installation or failure to properly secure a child restraint can lead to failure of the restraint. The child could be badly injured or killed.
- Follow the child restraint manufacturer’s directions exactly when installing an infant or child restraint.

1. Place the child seat in the center of the seating position. For some second row seats, you may need to recline the seat and/or raise the head restraint (if adjustable) to get a better fit. If the rear seat can be moved forward and rearward in the

vehicle, you may wish to move it to its rear-most position to make room for the child seat. You may also move the front seat forward to allow more room for the child seat.

2. Pull enough of the seat belt webbing from the retractor to pass it through the belt path of the child restraint. Do not twist the belt webbing in the belt path.
3. Slide the latch plate into the buckle until you hear a “click.”
4. Pull on the webbing to make the lap portion tight against the child seat.
5. To lock the seat belt, pull down on the shoulder part of the belt until you have pulled all the seat belt webbing out of the retractor. Then, allow the webbing to retract back into the retractor. As the webbing retracts, you will hear a clicking sound. This means the seat belt is now in the Automatic Locking mode.

6. Try to pull the webbing out of the retractor. If it is locked, you should not be able to pull out any webbing. If the retractor is not locked, repeat step 5.
7. Finally, pull up on any excess webbing to tighten the lap portion around the child restraint while you push the child restraint rearward and downward into the vehicle seat.
8. If the child restraint has a top tether strap and the seating position has a top tether anchorage, connect the tether strap to the anchorage and tighten the tether strap. See the section “Installing Child Restraints Using the Top Tether Anchorage” for directions to attach a tether anchor.
9. Test that the child restraint is installed tightly by pulling back and forth on the child seat at the belt path. It should not move more than 1 inch (25.4 mm) in any direction.

Any seat belt system will loosen with time, so check the belt occasionally, and pull it tight if necessary.

## Installing Child Restraints Using The Top Tether Anchorage

### WARNING!

Do not attach a tether strap for a rear-facing car seat to any location in front of the car seat, including the seat frame or a tether anchorage. Only attach the tether strap of a rear-facing car seat to the tether anchorage that is approved for that seating position, located behind the top of the vehicle seat. See the section “Lower Anchors and Tethers for Children (LATCH) Restraint System” for the location of approved tether anchorages in your vehicle.



1. Look behind the seating position where you plan to install the child restraint to find the tether anchorage. You may need to move the seat forward to provide better access to the tether anchorage. If there is no top tether anchorage for that seating position, move the child restraint to another position in the vehicle if one is available.
2. Route the tether strap to provide the most direct path for the strap between the anchor and the child seat. If your vehicle is equipped with adjustable rear head restraints, raise the head restraint, and where possible, route the tether strap under the head restraint and between the two posts. If not possible, lower the head restraint

and pass the tether strap around the outboard side of the head restraint.

3. Attach the tether strap hook of the child restraint to the top tether anchorage as shown in the diagram.

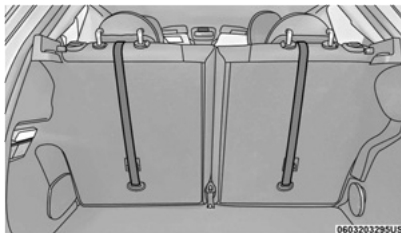

### Rear Seat Tether Strap Mounting

4. Remove slack in the tether strap according to the child restraint manufacturer's instructions.

### WARNING!

- An incorrectly anchored tether strap could lead to increased head motion and possible injury to the child. Use only the anchorage position directly behind the child seat to secure a child restraint top tether strap.
- If your vehicle is equipped with a split rear seat, make sure the tether strap does not slip into the opening between the seatbacks as you remove slack in the strap.

## SAFETY TIPS

### TRANSPORTING PASSENGERS

NEVER TRANSPORT PASSENGERS IN THE CARGO AREA.

### WARNING!

- Do not leave children or animals inside parked vehicles in hot weather. Interior heat build-up may cause serious injury or death.
- It is extremely dangerous to ride in a cargo area, inside or outside of a vehicle. In a collision, people riding in these areas are more likely to be seriously injured or killed.
- Do not allow people to ride in any area of your vehicle that is not equipped with seats and seat belts.
- Be sure everyone in your vehicle is in a seat and using a seat belt properly.

### TRANSPORTING PETS

Air Bags deploying in the front seat could harm your pet. An unrestrained pet will be thrown about and possibly injured, or injure a passenger during panic braking or in a collision.

Pets should be restrained in the rear seat (if equipped) in pet harnesses or pet carriers that are secured by seat belts.

## CONNECTED VEHICLES

Privacy of any wireless and wired communications cannot be assured. Third parties may unlawfully intercept information and private communications without your consent. For further information, refer to “Data Collection & Privacy” in your Uconnect Owner’s Manual Supplement or “Onboard Diagnostic System (OBD II) Cybersecurity” ➡ page 113.

### WARNING!

It is not possible to know or to predict all of the possible outcomes if your vehicle’s systems are breached. It may be possible that vehicle systems, including safety related systems, could be impaired or a loss of vehicle control could occur that may result in an accident involving serious injury or death.

## SAFETY CHECKS YOU SHOULD MAKE INSIDE THE VEHICLE

### Seat Belts

Inspect the seat belt system periodically, checking for cuts, frays, and loose parts. Damaged parts must be replaced immediately. Do not disassemble or modify the system.

If your vehicle is involved in a collision, or if you have questions regarding the seat belt or retractor conditions, take your vehicle to an authorized FCA dealer or authorized FCA Certified Collision Care Program facility for inspection.

## Air Bag Warning Light



The Air Bag Warning Light will turn on for four to eight seconds as a bulb check when the ignition switch is first placed in the ON/RUN position. If the light is either not on during starting, stays on, or turns on while driving, have the system inspected at an authorized dealer as soon as possible. After the bulb check, this light will illuminate with a single chime when a fault with the Air Bag System has been detected. It will stay on until the fault is removed. If the light comes on intermittently or remains on while driving, have an authorized dealer service the vehicle immediately ➡ page 143.

### Defroster



Check operation by selecting the defrost mode and place the blower control on high speed. You should be able to feel the air directed against the windshield. See an authorized dealer for service if your defroster is inoperable.

## Floor Mat Safety Information

Always use floor mats designed to fit your vehicle. Only use a floor mat that does not interfere with the operation of the accelerator, brake or clutch pedals. Only use a floor mat that is securely attached using the floor mat fasteners so it cannot slip out of position and interfere with the accelerator, brake or clutch pedals or impair safe operation of your vehicle in other ways.

### WARNING!

An improperly attached, damaged, folded, or stacked floor mat, or damaged floor mat fasteners may cause your floor mat to interfere with the accelerator, brake, or clutch pedals and cause a loss of vehicle control. To prevent SERIOUS INJURY or DEATH:

- 
 ALWAYS securely attach your floor mat using the floor mat fasteners. DO NOT install your floor mat upside down or turn your floor mat over. Lightly pull to confirm mat is secured using the floor mat fasteners on a regular basis.
- 
 ALWAYS REMOVE THE EXISTING FLOOR MAT FROM THE VEHICLE before installing any other floor mat. NEVER install or stack an additional floor mat on top of an existing floor mat.
- ONLY install floor mats designed to fit your vehicle. NEVER install a floor mat that cannot be properly attached and secured to your vehicle. If a floor mat needs to be replaced, only use a FCA approved floor mat for the specific make, model, and year of your vehicle.
- ONLY use the driver’s side floor mat on the driver’s side floor area. To check for interference, with the vehicle properly parked with the engine off, fully depress the accelerator, the brake, and the clutch pedal (if present) to check for interference. If your floor mat interferes with the operation of any pedal, or is not secure to the floor, remove the

(Continued)

**WARNING!**

floor mat from the vehicle and place the floor mat in your trunk.

- ONLY use the passenger's side floor mat on the passenger's side floor area.
- ALWAYS make sure objects cannot fall or slide into the driver's side floor area when the vehicle is moving. Objects can become trapped under accelerator, brake, or clutch pedals and could cause a loss of vehicle control.
- NEVER place any objects under the floor mat (e.g., towels, keys, etc.). These objects could change the position of the floor mat and may cause interference with the accelerator, brake, or clutch pedals.
- If the vehicle carpet has been removed and re-installed, always properly attach carpet to the floor and check the floor mat fasteners are secure to the vehicle carpet. Fully depress each pedal to check for interference with the accelerator, brake, or clutch pedals then re-install the floor mats.
- It is recommended to only use mild soap and water to clean your floor mats. After cleaning, always check your floor mat has been properly installed and is secured to your vehicle using the floor mat fasteners by lightly pulling mat.

## PERIODIC SAFETY CHECKS YOU SHOULD MAKE OUTSIDE THE VEHICLE

### Tires

Examine tires for excessive tread wear and uneven wear patterns. Check for stones, nails, glass, or other objects lodged in the tread or sidewall. Inspect the tread for cuts and cracks. Inspect sidewalls for cuts, cracks, and bulges. Check the wheel nuts for tightness. Check the tires (including spare) for proper cold inflation pressure.

### Lights

Have someone observe the operation of brake lights and exterior lights while you work the controls. Check turn signal and high beam indicator lights on the instrument panel.

### Door Latches

Check for proper closing, latching, and locking.

### Fluid Leaks

Check area under the vehicle after overnight parking for fuel, coolant, oil, or other fluid leaks. Also, if gasoline fumes are detected or if fuel, or brake fluid leaks are suspected. The cause should be located and corrected immediately.



# IN CASE OF EMERGENCY

## HAZARD WARNING FLASHERS

The Hazard Warning flasher switch is located on dashboard below the radio display.

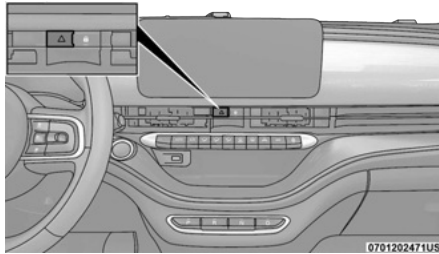

Push the switch to turn on the Hazard Warning flashers. When the switch is activated, all directional turn signals will flash on and off to warn oncoming traffic of an emergency. Push the switch a second time to turn off the Hazard Warning flashers.

Do not use this emergency warning system when the vehicle is in motion. Use it when your vehicle is disabled and it is creating a safety hazard for other motorists.

If it is necessary to leave the vehicle to go for service, the Hazard Warning flashers will continue to operate with the ignition key removed and the vehicle locked.

### NOTE:

With extended use, the Hazard Warning flashers may wear down your battery.

## SOS AND ASSIST SYSTEM

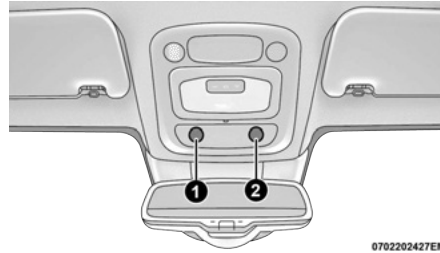

Assist And SOS Buttons

- 1 – SOS Button
- 2 – ASSIST Button

The overhead console contains an SOS and ASSIST button.

### WARNING!

ALWAYS obey traffic laws and pay attention to the road. ALWAYS drive safely with your hands on the steering wheel. You have full responsibility and

*(Continued)*

### WARNING!

assume all risks related to the use of the features and applications in this vehicle. Only use the features and applications when it is safe to do so. Failure to do so may result in an accident involving serious injury or death.

### NOTE:

- Your vehicle may be transmitting data as authorized by the subscriber → page 211.
- The SOS and ASSIST buttons will only function if you are connected to an operable LTE (voice/data) or 4G (data) network, which comes as a built in function. Other Uconnect services will only be operable if your Brand Connect service is active and connected to an operable LTE (voice/data) or 4G (data) network.

### SOS Call

1. Push the SOS Call button on the overhead console.

### NOTE:

In case the SOS Call button is pushed in error, there will be a ten second delay before the SOS Call system initiates a call to an SOS operator. To cancel the SOS Call connection, push the SOS Call button on the overhead console or press the cancellation button on the Device Screen. Termination of the SOS Call will turn off the green LED light on the overhead console.

2. The LED lights located within the SOS and ASSIST buttons on the overhead console will turn green once a connection to an SOS operator has been made.
3. Once a connection between the vehicle and an SOS operator is made, the SOS Call system may transmit the following important vehicle information to an SOS operator:
  - Indication that the occupant placed an SOS Call
  - The vehicle brand
  - The last known GPS coordinates of the vehicle
4. You should be able to speak with the SOS operator through the vehicle audio system to determine if additional help is needed.

**WARNING!**

ALWAYS obey traffic laws and pay attention to the road. ALWAYS drive safely with your hands on the steering wheel. You have full responsibility and assume all risks related to the use of the features and applications in this vehicle. Only use the features and applications when it is safe to do so. Failure to do so may result in an accident involving serious injury or death.

**NOTE:**

- Your vehicle may be transmitting data as authorized by the subscriber.
- Once a connection is made between the vehicle's SOS Call system and the SOS operator, the SOS operator may be able to open a

voice connection with the vehicle to determine if additional help is needed. Once the SOS operator opens a voice connection with the vehicle's SOS Call system, the operator should be able to speak with you or other vehicle occupants and hear sounds occurring in the vehicle. The vehicle's SOS Call system will attempt to remain connected with the SOS operator until the SOS operator terminates the connection.

5. The SOS operator may attempt to contact appropriate emergency responders and provide them with important vehicle information and GPS coordinates.

**WARNING!**

- If anyone in the vehicle could be in danger (e.g., fire or smoke is visible, dangerous road conditions or location), do not wait for voice contact from an Emergency Services Agent. All occupants should exit the vehicle immediately and move to a safe location.
- Never place anything on or near the vehicle's operable network and GPS antennas. You could prevent operable network and GPS signal reception, which can prevent your vehicle from placing an emergency call. An operable network and GPS signal reception is required for the SOS Call system to function properly.
- The SOS Call system is embedded into the vehicle's electrical system. Do not add aftermarket electrical equipment to the vehicle's electrical

*(Continued)*

**WARNING!**

system. This may prevent your vehicle from sending a signal to initiate an emergency call. To avoid interference that can cause the SOS Call system to fail, never add aftermarket equipment (e.g., two-way mobile radio, CB radio, data recorder, etc.) to your vehicle's electrical system or modify the antennas on your vehicle. IF YOUR VEHICLE LOSES BATTERY POWER FOR ANY REASON (INCLUDING DURING OR AFTER AN ACCIDENT), THE UCONNECT FEATURES, APPS AND SERVICES, AMONG OTHERS, WILL NOT OPERATE.

- Modifications to any part of the SOS Call system could cause the air bag system to fail when you need it. You could be injured if the air bag system is not there to help protect you.

**SOS Call System Limitations**

Vehicles sold in Mexico **DO NOT** have SOS Call system capabilities.

SOS or other emergency line operators in Mexico may not answer or respond to SOS system calls.

If the SOS Call system detects a malfunction, any of the following may occur at the time the malfunction is detected, and at the beginning of each ignition cycle:

- The overhead console lights located within the SOS and ASSIST buttons will continuously illuminate red.
- The Device Screen will display the following message: "Vehicle device requires service. Please contact an authorized dealer."

- An In-Vehicle Audio message will state “Vehicle device requires service. Please contact an authorized dealer.”

### WARNING!

- Ignoring the overhead console light could mean you will not have SOS Call services. If the overhead console light is illuminated, have an authorized dealer service the SOS Call system immediately.
- The Occupant Restraint Control module turns on the air bag Warning Light on the instrument panel if a malfunction in any part of the system is detected. If the Air Bag Warning Light is illuminated, have an authorized dealer service the Occupant Restraint Control system immediately.

Even if the SOS Call system is fully functional, factors beyond FCA US LLC’s control may prevent or stop the SOS Call system operation. These include, but are not limited to, the following factors:

- The ignition is in the OFF position
- The vehicle’s electrical systems are not intact
- The SOS Call system software and/or hardware are damaged during a crash
- The vehicle battery loses power or becomes disconnected during a vehicle crash
- LTE (voice/data) or 4G (data) network and/or Global Positioning Satellite signals are unavailable or obstructed
- Equipment malfunction at the SOS operator facility
- Operator error by the SOS operator

- LTE (voice/data) or 4G (data) network congestion
- Weather
- Buildings, structures, geographic terrain, or tunnels

### WARNING!

ALWAYS obey traffic laws and pay attention to the road. ALWAYS drive safely with your hands on the steering wheel. You have full responsibility and assume all risks related to the use of the features and applications in this vehicle. Only use the features and applications when it is safe to do so. Failure to do so may result in an accident involving serious injury or death.

### NOTE:

- Your vehicle may be transmitting data as authorized by the subscriber.
- Never place anything on or near the vehicle’s LTE (voice/data) or 4G (data) and GPS antennas. You could prevent LTE (voice/data) or 4G (data) and GPS signal reception, which can prevent your vehicle from placing an emergency call. An operable LTE (voice/data) or 4G (data) network connection and a GPS signal is required for the SOS Call system to function properly.

### NOTE:

Changes or modifications not expressly approved by the party responsible for compliance could void the user’s authority to operate the equipment.

### Automatic SOS — If Equipped

Automatic SOS is a hands-free safety service that can immediately connect you with help in the event

that your vehicle’s airbags deploy. Please refer to your provided radio supplement for complete information.

### ASSIST Call

The ASSIST button is used to automatically connect you to any one of the following support centers:

- Roadside Assistance – If you get a flat tire, or need a tow, just push the ASSIST button to be connected to someone who can help. Roadside Assistance will know what vehicle you’re driving and its location. Additional fees may apply for roadside assistance.
- Brand Connect Customer Care – In-vehicle support for Brand Connect.
- Vehicle Customer Care – Total support for all other vehicle issues.
- Uconnect Customer Care - Total support for Radio, Phone and NAV issues.

## TIRE SERVICE KIT

Use this QR code to access your digital experience.



### DESCRIPTION

If a tire is punctured, you can make an emergency repair using the Tire Service Kit located in the trunk beneath the load floor.

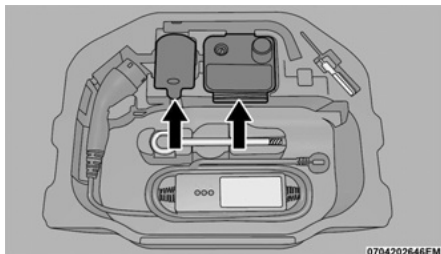

### Tire Service Kit Location

The Tire Service Kit includes:

- Sealant cartridge containing the sealing fluid.
- Filler tube.
- Adhesive label with the writing "Max. 50 mph (80 km/h)", to be attached in a position easily visible to the driver (e.g. on the dashboard) after repairing the tire.
- Air compressor, complete with pressure gauge and connectors.
- An instruction pamphlet for reference in prompt and correct use of the Tire Service Kit, which must be then given to the personnel dealing with the sealant-treated tire.
- A pair of protective gloves.
- Adaptors for inflating different elements.

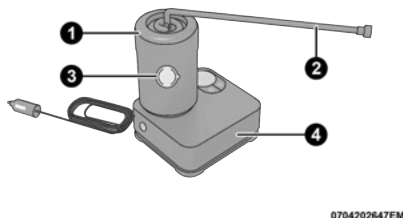

### Tire Service Kit Components

- 1 – Sealant Cartridge
- 2 – Filler Tube
- 3 – Adhesive Label
- 4 – Air Compressor

#### NOTE:

The sealant is effective with external temperatures of between -40 °F (-40 °C) and 122 °F (50 °C). The sealant has an expiration date.

To use the Tire Service Kit, proceed as follows:

1. Stop the vehicle in a position where you can repair the tire safely. You should be as far as possible from the side of the road, and in a position that is not dangerous for oncoming traffic. Activate the Hazard Warning Flashers, remove the safety triangle from the trunk, and place it at a suitable distance from the vehicle to make other drivers aware of your presence.
2. Verify that the valve stem (on the wheel with the deflated tire) is in a position that is near to the

ground. This will allow the tire service kit hoses to reach the valve stem and keep the tire repair kit flat on the ground. If equipped, use all available safety equipment required by law.

3. Place the gear selector to PARK (P).

## INFLATION PROCEDURE

### WARNING!

- The information required by current legislation is shown on the kit cartridge label. Read the cartridge label before use, avoid improper use.
- Do not attempt to seal a tire on the side of the vehicle closest to traffic. Pull far enough off the road to avoid the danger of being hit when using the Tire Service Kit.
- Do not remove foreign bodies from the tire.
- Do not leave the compressor running for more than 20 minutes, this may cause overheating.
- Do not use Tire Service Kit or drive the vehicle under the following circumstances:
  - If the puncture in the tire tread is approximately 1/4 inch (6 mm) or larger.
  - If the tire has any sidewall damage.
  - If the tire has any damage from driving with extremely low tire pressure.
  - If the tire has any damage from driving on a flat tire.

(Continued)

**WARNING!**

- If the wheel has any damage.
- If you are unsure of the condition of the tire or the wheel.
- Keep Tire Service Kit away from open flames or heat sources.
- A loose Tire Service Kit thrown forward in a collision or hard stop could endanger the occupants of the vehicle. Always stow the Tire Service Kit in the place provided. Failure to follow these warnings can result in injuries that are serious or fatal to you, your passengers, and others around you.
- Take care not to allow the contents of Tire Service Kit to come in contact with hair, eyes, or clothing. Tire Service Kit sealant is harmful if inhaled, swallowed, or absorbed through the skin. It causes skin, eye, and respiratory irritation. Flush immediately with plenty of water if there is any contact with eyes or skin. Change clothing as soon as possible, if there is any contact with clothing.
- Tire Service Kit Sealant solution contains latex. In case of an allergic reaction or rash, consult a physician immediately. Keep Tire Service Kit out of reach of children. If swallowed, rinse mouth immediately with plenty of water and drink plenty of water. Do not induce vomiting! Consult a physician immediately.

1. Apply the Electric Park Brake.
2. Insert the sealant cartridge containing the sealing fluid in the proper compressor holder, pushing down hard. Unscrew the tire valve cap, take out the filler tube and tighten the fitting on the tire valve.

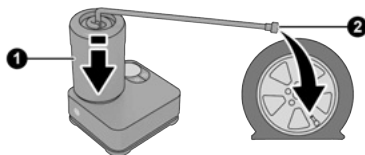

0704202648EM

**Attaching Filler Tube To Deflated Tire**

- 1 — Sealant Cartridge  
2 — Filler Tube

3. Make sure the power switch of the compressor is in the O (off) position.
4. Insert the plug into the power outlet in the center console, then start the engine.

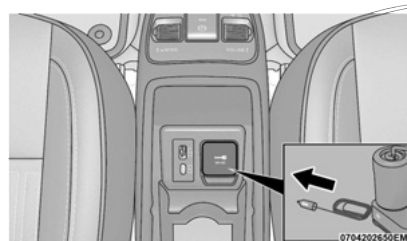
**Center Console Power Outlet**

5. Start the compressor by placing the power switch in the I (on) position.

6. Inflate the tire to the pressure indicated on the tire placard, located on the driver's side B-pillar or the rear edge of the driver's side door → page 194. In order to obtain a more precise reading, check the pressure value on pressure gauge with the compressor off.

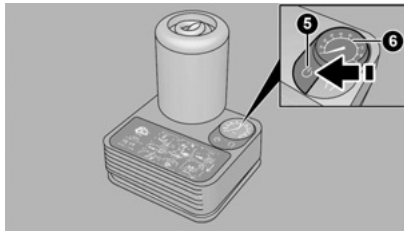

**Air Compressor**

- 5 — Power Switch  
6 — Pressure Gauge

7. If the pressure is not at least 26 psi (1.8 bar) after 15 minutes, disengage the compressor from the valve and power outlet. Then, move the vehicle forwards approximately 33 ft (10 m) in order to distribute the sealant inside the tire evenly, and then repeat the inflation operation.
8. If you still cannot obtain a pressure of at least 26 psi (1.8 bar) within 15 minutes of turning the compressor on, do not drive the vehicle, and contact an authorized dealer.

9. Drive the vehicle for about 5 miles (8 km), stop, apply the Electric Park Brake, and recheck the tire pressure.
10. If the pressure is less than 26 psi (1.8 bar), **DO NOT** drive the vehicle, and see an authorized dealer.
11. If a pressure value of at least 26 psi (1.8 bar) is detected, restore the correct pressure (with engine running and Electric Park Brake applied), and drive immediately with great care to an authorized dealer.

**WARNING!**

Tire Service Kit is not a permanent flat tire repair. Have the tire inspected and repaired or replaced after using Tire Service Kit. Do not exceed 50 mph (80 km/h) until the tire is repaired or replaced. Failure to follow this warning can result in injuries that are serious or fatal to you, your passengers, and others around you. Have the tire checked as soon as possible at an authorized dealer.

12. Apply the adhesive label from the sealant bottle where it can be easily seen by the driver as a reminder that the tire has been treated with a Tire Service Kit, as well as not to exceed the speed restriction for the treated tire.

**WARNING!**

Do not adhere the speed restriction sticker to the padded area on the steering wheel. Adhering the speed restriction sticker to the padded area on the steering wheel is dangerous because the air bag may not operate (deploy) normally resulting in serious injury. In addition, do not adhere the sticker to areas where warning lights or the speedometer cannot be viewed.

**CHECKING AND RESTORING TIRE PRESSURE**

The compressor can also be used to check and, if necessary, restore the tire pressure.

Proceed as follows:

1. Release the quick connector and connect it directly to the valve of the tire to be inflated.

- Push the air release button.

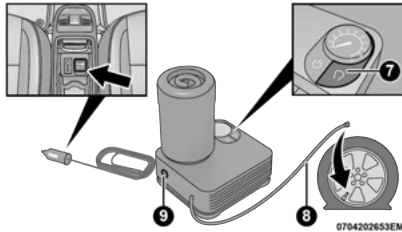

Air Compressor Components

- 7 — Air Release Button
- 8 — Quick Connector
- 9 — Release Button

## SEALANT CARTRIDGE REPLACEMENT

### NOTE:

Only use original cartridges, which can be purchased at an authorized dealer.

Proceed as follows:

- Remove the sealant cartridge by pushing the release button located on the side of the compressor.
- Insert the new sealant cartridge by pushing downward firmly.

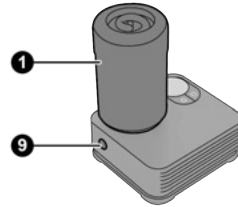

0704202654EM

Sealant Cartridge Replacement

- 1 — Sealant Cartridge
- 9 — Release Button

## JUMP STARTING

If your vehicle has a discharged battery, it can be jump started using a set of jumper cables and a battery in another vehicle or by using a portable battery booster pack. Jump starting can be dangerous if done improperly, so please follow the procedures in this section carefully.

### NOTE:

When using a portable battery booster pack, follow the manufacturer's operating instructions and precautions.

The vehicle requires its 12 Volt battery power to turn-on the vehicle's high voltage battery. The high voltage battery is used to charge the 12 Volt battery, provide electric vehicle operation. If the 12 Volt battery has been discharged, the vehicle can be jump started using a set of jumper cables and a battery in another vehicle or by using a portable battery booster pack.

If the vehicle's high voltage battery has also been discharged, it will need to be recharged to a minimum operating State Of Charge (SOC) before the vehicle can be operated:

- If the vehicle can be connected to a Level 1 or Level 2 charger where it is currently parked, the vehicle will still require a jump start to allow the vehicle to begin the battery charging process. Once the vehicle charging has begun (indicated by the charge status indicator on top of the vehicle's instrument panel), the jumper cables can be removed from the vehicle jump posts.
- If the vehicle cannot be connected to a Level 1 or Level 2 charger where it is currently parked, the vehicle can be moved by connecting 12 Volt power to the vehicle's jump posts and then shifting the transmission from PARK (P) into NEUTRAL (N). Power provided by the jumper cables will also allow the Electric Park Brake to be released. Carefully move the vehicle to a Level 1 or Level 2 charge location. While the vehicle is being moved, the external 12 Volt power must remain connected to the vehicle jump posts.

### NOTE:

Be careful when moving the vehicle - ensure that control of the vehicle is maintained. Also, ensure that vehicle is secured to prevent unintentional movement during and after moving the vehicle. If the external 12 Volt power becomes disconnected from the vehicle jump posts or there is an interruption of the 12 Volt power while moving the vehicle, the vehicle's transmission may engage PARK. Do not allow the jumper cables to come in contact with each other or to the vehicle, this will result in a short.

When the vehicle is at the charging location, shift the transmission back to PARK, apply the Electric Park Brake, and start the high voltage battery charging. Once the vehicle has been secured against unintentional movement and high voltage battery charging has been initiated, the jumper cables can be removed from the vehicle jump posts.

**WARNING!**

Do not attempt jump starting if the battery is frozen. It could rupture or explode and cause personal injury.

**CAUTION!**

Do not use a portable battery booster pack or any other booster source with a system voltage greater than 12 Volts or damage to the battery, starter motor, alternator or electrical system may occur.

**PREPARATIONS FOR JUMP START**

The vehicle's jump starting remote posts are located under the hood, on the driver's side.

The remote positive (+) post is covered with a protective cap located on left side of the battery.

The remote negative (-) post is located on right side of the battery.

**Jump Starting Locations**

- 1 – Remote Positive (+) Post
- 2 – Remote Negative (-) Post
- 3 – Battery Sensor Nut

See the following steps to prepare for jump starting:

1. Apply the parking brake, shift the automatic transmission into PARK (P) and turn the ignition to the OFF position.
2. Turn off the heater, radio, and all electrical accessories.
3. Pull upward and remove the protective cover over the remote positive (+) battery post.
4. If using another vehicle to jump start the 12 Volt electrical system, park the vehicle within the reach of the jumper cables, apply the parking brake and make sure the ignition is OFF.

**WARNING!**

- Do not allow vehicles to touch each other as this could establish a ground connection and personal injury could result.
- Take care to avoid the radiator cooling fan whenever the hood is raised. It can start anytime the ignition switch is ON. You can be injured by moving fan blades.
- Remove any metal jewelry such as rings, watch bands and bracelets that could make an inadvertent electrical contact. You could be seriously injured.
- Batteries contain sulfuric acid that can burn your skin or eyes and generate hydrogen gas which is flammable and explosive. Keep open flames or sparks away from the battery.

**JUMP STARTING PROCEDURE****WARNING!**

Failure to follow this jump starting procedure could result in personal injury or property damage due to battery explosion.

**CAUTION!**

Failure to follow these procedures could result in damage to the charging system of the booster vehicle or the discharged vehicle.



### Connecting The Jumper Cables

1. Connect the positive (+) end of the jumper cable to the remote positive (+) post of the discharged vehicle.

#### NOTE:

The remote positive (+) post is located in the engine compartment on the driver's side under the cover on left side of the battery.

2. Connect the opposite end of the positive (+) jumper cable to the positive (+) post of the booster battery.
3. Connect the negative (-) end of the jumper cable to the negative (-) post of the booster battery.
4. Connect the opposite end of the negative (-) jumper cable to the remote negative post or a good ground of the discharged vehicle. A "ground" is an exposed metallic/unpainted part of the engine, frame or chassis, such as an accessory bracket or large bolt. The ground must be away from the battery and the fuel injection system.

#### NOTE:

The remote negative (-) post is located in the front of the engine compartment on the driver's side on right side of the battery.

#### WARNING!

Do not connect the jumper cable to the negative (-) post of the discharged battery. The resulting electrical spark could cause the battery to explode and could result in personal injury.

5. Start the engine in the vehicle that has the booster battery, let the engine idle a few minutes and then cycle the ignition to ON/RUN in the vehicle with the discharged battery.
6. After a couple minutes (depending on the level of 12 Volt battery discharge), attempt to start the vehicle. Once the vehicle starts, follow the disconnecting procedure.

### Disconnecting The Jumper Cables

1. Disconnect the negative (-) end of the jumper cable from the remote negative (-) post of the vehicle with the discharged battery.
2. Disconnect the opposite end of the negative (-) jumper cable from the negative (-) post of the booster battery.
3. Disconnect the positive (+) end of the jumper cable from the positive (+) post of the booster battery.
4. Disconnect the opposite end of the positive (+) jumper cable from the remote positive (+) post of the discharged vehicle, and reinstall the protective cap.
5. Close the cover of the Front Power Distribution Center.

If frequent jump starting is required to start your vehicle you should have the battery and charging system inspected at an authorized dealer.

#### CAUTION!

Accessories plugged into the vehicle power outlets draw power from the vehicle's battery, even when not in use (i.e., cellular devices, etc.). Eventually, if plugged in long enough without engine operation, the vehicle's battery will discharge sufficiently to degrade battery life and/or prevent the engine from starting.

## IF YOUR ENGINE OVERHEATS

If the vehicle is overheating, it will need to be serviced by an authorized dealer.

In any of the following situations, you can reduce the potential for overheating by taking the appropriate action.

- On the highways — slow down.
- In city traffic — while stopped, place the transmission in NEUTRAL (N), but do not increase the engine idle speed while preventing vehicle motion with the brakes.

#### NOTE:

There are steps that you can take to slow down an impending overheat condition:

- If your Air Conditioner (A/C) is on, turn it off. The A/C system adds heat to the engine cooling system and turning the A/C off can help remove this heat.
- You can also turn the temperature control to maximum heat, the mode control to floor and the blower control to high. This allows the heater core to act as a supplement to the radiator and aids in removing heat from the engine cooling system.

**WARNING!**

You or others can be badly burned by hot engine coolant (antifreeze) or steam from your radiator. If you see or hear steam coming from under the hood, do not open the hood until the radiator has had time to cool. Never try to open a cooling system pressure cap when the radiator or coolant bottle is hot.

**CAUTION!**

Driving with a hot cooling system could damage your vehicle. If the temperature gauge reads HOT (H), pull over and stop the vehicle. Idle the vehicle with the air conditioner turned off until the pointer drops back into the normal range. If the pointer remains on HOT (H), and you hear continuous chimes, turn the engine off immediately and call for service.

**FREING A STUCK VEHICLE**

If your vehicle becomes stuck in mud, sand, or snow, it can often be moved using a rocking motion. Turn the steering wheel right and left to clear the area around the front wheels. Then shift back and forth between DRIVE (D) and REVERSE (R), while gently pressing the accelerator. Use the least amount of accelerator pedal pressure that will maintain the rocking motion without spinning the wheels or racing the engine.

**CAUTION!**

- Racing the engine or spinning the wheels may lead to transmission overheating and failure. Allow the engine to idle with the transmission in NEUTRAL for at least one minute after every five rocking-motion cycles. This will minimize overheating and reduce the risk of transmission failure during prolonged efforts to free a stuck vehicle.
- When "rocking" a stuck vehicle by shifting between DRIVE and REVERSE, do not spin the wheels faster than 15 mph (24 km/h), or drivetrain damage may result.
- Revving the engine or spinning the wheels too fast may lead to transmission overheating and failure. It can also damage the tires. Do not spin the wheels above 30 mph (48 km/h) while in gear (no transmission shifting occurring).

**NOTE:**

Shifts between DRIVE and REVERSE can only be achieved at wheel speeds of 5 mph (8 km/h) or less. Whenever the transmission remains in NEUTRAL (N) for more than two seconds, you must press the brake pedal to engage DRIVE or REVERSE.

Push the ESC OFF button to place the Electronic Stability Control (ESC) system in "Partial OFF" mode, before rocking the vehicle. Once the vehicle has been freed, push the ESC OFF button again to restore "ESC On" mode.

**WARNING!**

Fast spinning tires can be dangerous. Forces generated by excessive wheel speeds may cause damage, or even failure, of the axle and tires. A tire could explode and injure someone. Do not spin your vehicle's wheels faster than 30 mph (48 km/h) or for longer than 30 seconds continuously without stopping when you are stuck and do not let anyone near a spinning wheel, no matter what the speed.

**TOWING A DISABLED VEHICLE**

This section describes procedures for towing a disabled vehicle using a commercial towing service.

Towing Condition	Wheels OFF The Ground	Single-Speed Transmission
Flat Tow	NONE	<b>NOT ALLOWED</b>
Wheel Lift or Dolly Tow	Rear	<b>NOT ALLOWED</b>
	Front	<b>NOT ALLOWED</b>
Flatbed	<b>ALL</b>	OK

This vehicle must be towed with the wheels OFF the ground.

The tow ring provided with the car is housed in the tool bag under the boot mat. The car may not be towed. It can only be transported on a tow truck.

**CAUTION!**

- Do not use sling type equipment when towing. Vehicle damage may occur.

*(Continued)*

**CAUTION!**

- When securing the vehicle to a flat bed truck, do not attach to front or rear suspension components. Damage to your vehicle may result from improper towing.

**CAUTION!**

To avoid damage to your vehicle or tires, observe the following precautions:

- Because of restricted traction device clearance between tires and other suspension components, it is important that only traction devices in good condition are used. Broken devices can cause serious damage. Stop the vehicle immediately if noise occurs that could indicate device breakage. Remove the damaged parts of the device before further use.
- Install device as tightly as possible and then retighten after driving about ½ mile (0.8 km).
- Do not exceed 30 mph (48 km/h).
- Drive cautiously and avoid severe turns and large bumps, especially with a loaded vehicle.
- Do not drive for a prolonged period on dry pavement.
- Observe the traction device manufacturer's instructions on the method of installation, operating speed, and conditions for use. Always use the suggested operating speed of the device manufacturer's if it is less than 30 mph (48 km/h).

**ATTACHING THE TOW HOOK**

Proceed as follows:

- Release the cap.

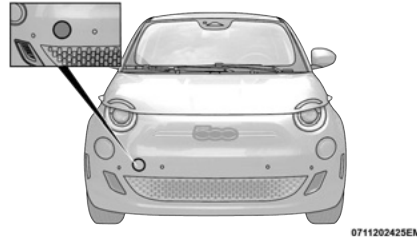

**Front Tow Hook Location**

- Take the tow ring out of its housing in the tool support.
- Fully tighten it on the threaded pin.



**Front Tow Hook Installed**

**CAUTION!**

Before tightening the ring clean the threaded housing thoroughly. Make sure that the ring is fully fastened in the housing before towing the car.

**ENHANCED ACCIDENT RESPONSE SYSTEM (EARS)**

This vehicle is equipped with an Enhanced Accident Response System.

This feature is a communication network that takes effect in the event of an impact → page 154.

**EVENT DATA RECORDER (EDR)**

This vehicle is equipped with an Event Data Recorder (EDR). The main purpose of an EDR is to record data that will assist in understanding how a vehicle's systems performed under certain crash or near crash-like situations, such as an air bag deployment or hitting a road obstacle → page 155.



Mileage or time passed (whichever comes first)	20,000	30,000	40,000	50,000	60,000	70,000	80,000	90,000	100,000	110,000	120,000	130,000	140,000	150,000
Or Years:	2	3	4	5	6	7	8	9	10	11	12	13	14	15
Or Kilometers:	32,000	48,000	64,000	80,000	96,000	112,000	128,000	144,000	160,000	176,000	192,000	208,000	224,000	240,000
Inspect the brake linings. Replace as necessary.	X		X		X		X		X		X		X	
Inspect parking brake function.	X		X		X		X		X		X		X	
<b>Additional Maintenance</b>														
Replace cabin air filter.	X		X		X		X		X		X		X	
Clean and lube sun roof tracks.	X	X	X	X	X	X	X	X	X	X	X	X	X	X
Flush and replace the coolant in the Power Electronics and Battery Thermal Loop Systems at 10 years or 150,000 miles (240,000 km) whichever comes first.									X					X

**WARNING!**

- You can be badly injured working on or around a motor vehicle. Do only service work for which you have the knowledge and the right equipment. If you have any doubt about your ability to perform a service job, take your vehicle to a competent mechanic.
- Failure to properly inspect and maintain your vehicle could result in a component malfunction and effect vehicle handling and performance. This could cause an accident.

## UNDERHOOD COMPARTMENT

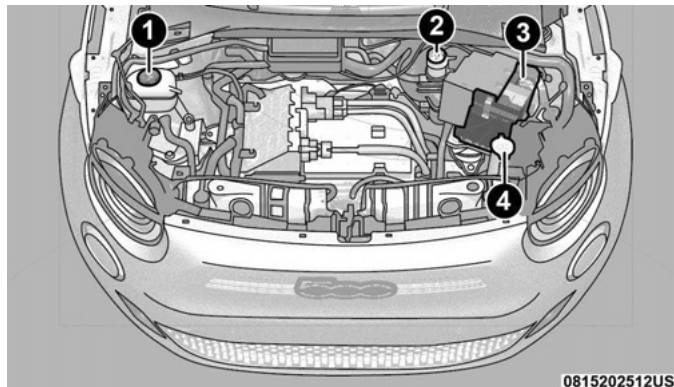

0815202512US

1 – Motor coolant

2 – Brake fluid

3 – Battery

4 – Windshield washer fluid

### ADDING WASHER FLUID

The windshield washer fluid reservoir is located in the underhood compartment, and the fluid level should be checked at regular intervals. Fill the reservoir with windshield washer solvent (not coolant/ antifreeze). Refer to "Underhood Compartment" in this section for further information.

#### WARNING!

Commercially available windshield washer solvents are flammable. They could ignite and burn you. Care

*(Continued)*

#### WARNING!

must be exercised when filling or working around the washer solution.

### MAINTENANCE-FREE BATTERY 12 VOLT

Your vehicle is equipped with a maintenance-free 12 Volt battery. You will never have to add water, nor is periodic maintenance required.

#### WARNING!

- Battery fluid is a corrosive acid solution and can burn or even blind you. Do not allow battery fluid to contact your eyes, skin, or clothing. Do not lean over a battery when attaching clamps. If acid splashes in eyes or on skin, flush the area immediately with large amounts of water. Refer to "Jump Starting Procedure" in "In Case Of Emergency" for further information.

*(Continued)*

**WARNING!**

- Battery gas is flammable and explosive. Keep flame or sparks away from the battery. Do not use a booster battery or any other booster source with an output greater than 12 Volts. Do not allow cable clamps to touch each other.
- Battery posts, terminals, and related accessories contain lead and lead compounds. Wash hands after handling.
- The battery in this vehicle has a vent hose that should not be disconnected and should only be replaced with a battery of the same type (vented).

**CAUTION!**

- It is essential when replacing the cables on the battery that the positive cable is attached to the positive post and the negative cable is attached to the negative post. Battery posts are marked positive (+) and negative (-) and are identified on the battery case. Cable clamps should be tight on the terminal posts and free of corrosion.
- If a 12 Volt Low Voltage Battery System "fast charger" is used while the battery is in the vehicle, disconnect both vehicle battery cables before connecting the charger to the battery. Do not use a "fast charger" to provide starting voltage.

**VEHICLE MAINTENANCE**

An authorized dealer has the qualified service personnel, special tools, and equipment to perform

all service operations in an expert manner. Service Manuals are available which include detailed service information for your vehicle. Refer to these Service Manuals before attempting any procedure yourself.

**WARNING!**

You can be badly injured working on or around a motor vehicle. Only do service work for which you have the knowledge and the proper equipment. If you have any doubt about your ability to perform a service job, take your vehicle to a competent mechanic.

**AIR CONDITIONER MAINTENANCE**

For best possible performance, your air conditioner should be checked and serviced by an authorized dealer at the start of each warm season. This service should include cleaning of the condenser fins and a performance test.

**WARNING!**

- Use only refrigerants and compressor lubricants approved by the manufacturer for your air conditioning system. Some unapproved refrigerants are flammable and can explode, injuring you. Other unapproved refrigerants or lubricants can cause the system to fail, requiring costly repairs. Refer to Warranty Information Book, for further warranty information.
- The air conditioning system contains refrigerant under high pressure. To avoid risk of personal injury or damage to the system, adding refrigerant

*(Continued)*

**WARNING!**

or any repair requiring lines to be disconnected should be done by an experienced technician.

**CAUTION!**

Do not use chemical flushes in your air conditioning system as the chemicals can damage your air conditioning components. Such damage is not covered by the New Vehicle Limited Warranty.

**Refrigerant Recovery And Recycling**

R-1234yf Air Conditioning Refrigerant is a Hydrofluoroolefin (HFO) that is endorsed by the Environmental Protection Agency and is an ozone-friendly substance with a low global-warming potential. It is recommended that air conditioning service be performed by an authorized dealer using recovery and recycling equipment.

**NOTE:**

Use only the manufacturer approved A/C system PAG compressor oil, and refrigerants.

**Cabin Air Filter**

Refer to the Maintenance Plan in this chapter for the proper maintenance intervals ➞ page 178.

**BODY LUBRICATION**

Locks and all body pivot points, including such items as seat tracks, door hinge pivot points and rollers, liftgate, tailgate, decklid, sliding doors and hood hinges, should be lubricated periodically with a lithium-based

grease, such as Mopar® Spray White Lube to ensure quiet, easy operation and to protect against rust and wear. Prior to the application of any lubricant, the parts concerned should be wiped clean to remove dust and grit; after lubricating, excess oil and grease should be removed. Particular attention should also be given to hood latching components to ensure proper function. When performing other underhood services, the hood latch release mechanism, and safety catch should be cleaned and lubricated.

The external lock cylinders should be lubricated twice a year, preferably in the Autumn and Spring. Apply a small amount of a high quality lubricant, such as Mopar® Lock Cylinder Lubricant directly into the lock cylinder.

## WINDSHIELD WIPER BLADES

Clean the rubber edges of the wiper blades and the windshield periodically with a sponge or soft cloth and a mild nonabrasive cleaner. This will remove accumulations of salt or road film.

Operation of the wipers on dry glass for long periods may cause deterioration of the wiper blades. Always use washer fluid when using the wipers to remove salt or dirt from a dry windshield.

Avoid using the wiper blades to remove frost or ice from the windshield. Keep the blade rubber out of contact with petroleum products such as engine oil, gasoline, etc.

### NOTE:

Life expectancy of wiper blades varies depending on geographical area and frequency of use. If chattering, marks, water lines or wet spots are present, clean the wiper blades or replace as necessary.

## Front Wiper Blade Removal/Installation

### CAUTION!

Do not allow the wiper arm to spring back against the glass without the wiper blade in place or the glass may be damaged.

1. Lift the wiper arm to raise the wiper blade off of the glass, until the wiper arm is in the full upright position.

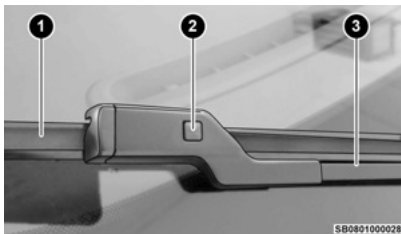

Windshield Wiper Arm And Blade

- 1 – Wiper Blade
  - 2 – Locking Button
  - 3 – Wiper Arm
2. To disengage the wiper blade from the wiper arm, press the locking button.
  3. Insert the new blade making sure it is securely locked into place.
  4. Gently lower the wiper arm onto the glass in the original position.

## Rear Wiper Blade Removal/Installation

1. Lift the rear wiper arm pivot cap away from the wiper arm to allow the rear wiper arm nut to be exposed.

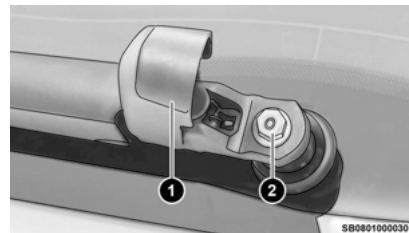

Wiper Pivot Cap In Unlocked Position

- 1 – Wiper Arm Pivot Cap
- 2 – Nut

2. Undo the nut that secures it to the pivot pin; remove the expired rear wiper arm and correctly position the new arm and tighten the nut fully.
3. Lower the cover back to original position and snap the wiper pivot cap back into place.
4. Lower the wiper blade onto the glass.

## COOLING SYSTEM

The cooling system is sealed. Never try to refill the cooling system. Always refer to an authorized dealer.



**WARNING!**

- You or others can be badly burned by hot engine coolant (antifreeze) or steam from your radiator. If you see or hear steam coming from under the hood, do not open the hood until the radiator has had time to cool. Never open a cooling system pressure cap when the radiator or coolant bottle is hot.
- Keep hands, tools, clothing, and jewelry away from the radiator cooling fan when the hood is raised. The fan starts automatically and may start at any time, whether the engine is running or not.
- When working near the radiator cooling fan, disconnect the fan motor lead and turn the ignition to the OFF mode. The fan is temperature controlled and can start at any time the ignition is in the ON mode.

## Coolant Checks

Check the traction system coolant (antifreeze) protection every 12 months (before the onset of freezing weather, where applicable). If the traction system coolant is dirty, the system should be drained, flushed, and refilled with fresh OAT coolant (conforming to MS-12106) only by an authorized dealer. Check the front of the A/C condenser for any accumulation of bugs, leaves, etc. If dirty, clean by gently spraying water from a garden hose vertically down the face of the condenser.

## Cooling System — Drain, Flush And Refill

**NOTE:**

Some vehicles require special tools to add coolant properly. Failure to fill these systems properly could lead to severe internal traction system damage. If any coolant is needed to be added to the system please contact an authorized dealer.

If the traction system coolant (antifreeze) is dirty or contains visible sediment, have an authorized dealer clean and flush with OAT coolant (conforming to MS.90032).

For the proper maintenance intervals ⇨ page 178.

## Selection Of Coolant

For further information ⇨ page 206.

**NOTE:**

- Mixing of motor coolant (antifreeze) other than specified Organic Additive Technology (OAT) motor coolant, may result in motor damage and may decrease corrosion protection. OAT motor coolant is different and should not be mixed with Hybrid Organic Additive Technology (HOAT) motor coolant or any “globally compatible” coolant. If a non-OAT motor coolant is introduced into the cooling system in an emergency, the cooling system will need to be drained, flushed, and refilled with fresh OAT coolant (conforming to MS.90032), by an authorized dealer as soon as possible.
- Do not use water alone or alcohol-based motor coolant products. Do not use additional rust inhibitors or antirust products, as they may not be

compatible with the radiator motor coolant and may plug the radiator.

- This vehicle has not been designed for use with propylene glycol-based motor coolant. Use of propylene glycol-based motor coolant is not recommended.
- Some vehicles require special tools to add coolant properly. Failure to fill these systems properly could lead to severe internal motor damage. If any coolant is needed to be added to the system please contact an authorized dealer.

## Adding Coolant

The vehicle has been built with an improved traction system coolant (OAT coolant conforming to MS.90032) that allows extended maintenance intervals. This traction system coolant (antifreeze) can be used up to 10 years or 150,000 miles (240,000 km) before replacement. To prevent reducing this extended maintenance period, it is important to use the same traction system coolant (OAT coolant conforming to MS.90032) throughout the life of your vehicle.

**NOTE:**

- It is the owner's responsibility to maintain the proper level of protection against freezing according to the temperatures occurring in the area where the vehicle is operated.
- If any coolant is needed to be added to the system, please contact an authorized dealer.

## Cooling System Pressure Cap

The cap must be fully tightened to prevent loss of traction system coolant (antifreeze), and to ensure that

traction system coolant will return to the radiator from the coolant recovery tank.

The cap should be inspected and cleaned if there is any accumulation of foreign material on the sealing surfaces.

#### WARNING!

- Do not open hot traction cooling system. Never add traction system coolant (antifreeze) when the motor is overheated. Do not loosen or remove the cap to cool an overheated motor. Heat causes pressure to build up in the cooling system. To prevent scalding or injury, do not remove the pressure cap while the system is hot or under pressure.
- Do not use a pressure cap other than the one specified for your vehicle. Personal injury or motor damage may result.

### Disposal Of Used Coolant

Used ethylene glycol-based coolant (antifreeze) is a regulated substance requiring proper disposal. Check with your local authorities to determine the disposal rules for your community. To prevent ingestion by animals or children, do not store ethylene glycol-based coolant in open containers or allow it to remain in puddles on the ground. If ingested by a child or pet, seek emergency assistance immediately. Clean up any ground spills immediately.

### Coolant Level

The coolant expansion bottle provides a quick visual method for determining that the coolant level is

adequate. With engine off and cold, the level of the motor coolant (antifreeze) in the bottle should be between the “MIN” and “MAX” marks.

### Cooling System Notes

#### NOTE:

When the vehicle is stopped after a few miles/kilometers of operation, you may observe vapor coming from the front of the engine compartment. This is normally a result of moisture from rain, snow, or high humidity accumulating on the radiator and being vaporized when the thermostat opens, allowing hot traction system coolant (antifreeze) to enter the radiator.

If an examination of your engine compartment shows no evidence of radiator or hose leaks, the vehicle may be safely driven. The vapor will soon dissipate.

- Do not overfill the coolant expansion bottle.
- Check the coolant freeze point in the radiator and in the coolant expansion bottle. If traction system coolant needs to be added, the contents of the coolant expansion bottle must also be protected against freezing.
- If frequent traction system coolant additions are required, the cooling system should be pressure tested for leaks.
- Maintain engine coolant concentration at a minimum of 50% OAT coolant (conforming to MS.90032) and distilled water for proper corrosion protection of your traction system which contains aluminum components.

- Make sure that the coolant expansion bottle overflow hoses are not kinked or obstructed.
- Keep the front of the radiator clean. If your vehicle is equipped with air conditioning, keep the front of the condenser clean.
- Do not change the thermostat for Summer or Winter operation. If replacement is ever necessary, install ONLY the correct type thermostat. Other designs may result in unsatisfactory traction system cooling performance, poor gas mileage, and increased emissions.

### BRAKE SYSTEM

In order to ensure brake system performance, all brake system components should be inspected periodically  page 178.

#### WARNING!

Riding the brakes can lead to brake failure and possibly a collision. Driving with your foot resting or riding on the brake pedal can result in abnormally high brake temperatures, excessive lining wear, and possible brake damage. You would not have your full braking capacity in an emergency.

### Fluid Level Check — Brake Master Cylinder

The fluid level of the master cylinder should be checked when performing under the hood service or immediately if the Brake System Warning Light indicates system failure. If necessary, add fluid to bring level within the designated marks on the side of the

reservoir of the brake master cylinder. Be sure to clean the top of the master cylinder area before removing cap. With disc brakes the fluid level can be expected to fall as the brake linings wear. However, an unexpected drop in fluid level may be caused by a leak and a system check should be conducted ➞ page 206.

#### WARNING!

- Use only the manufacturer recommended brake fluid ➞ page 206. Using the wrong type of brake fluid can severely damage your brake system and/or impair its performance. The proper type of brake fluid for your vehicle is also identified on the original factory installed hydraulic master cylinder reservoir.
- To avoid contamination from foreign matter or moisture, use only new brake fluid or fluid that has been in a tightly closed container. Keep the master cylinder reservoir cap secured at all times. Brake fluid in an open container absorbs moisture from the air resulting in a lower boiling point. This may cause it to boil unexpectedly during hard or prolonged braking, resulting in sudden brake failure. This could result in a collision.
- Overfilling the brake fluid reservoir can result in spilling brake fluid on hot engine parts, causing the brake fluid to catch fire. Brake fluid can also damage painted and vinyl surfaces, care should be taken to avoid its contact with these surfaces.
- Do not allow petroleum-based fluid to contaminate the brake fluid. Brake seal components could be damaged, causing partial or complete brake failure. This could result in a collision.

## AUTOMATIC TRANSMISSION

### Selection Of Lubricant

It is important to use the proper transmission fluid to ensure optimum transmission performance and life. Use the manufacturer specified transmission fluid ➞ page 207. It is important to maintain the transmission fluid at the correct level using the recommended fluid.

#### NOTE:

No chemical flushes should be used in any transmission; only the approved lubricant should be used.

#### CAUTION!

Using a transmission fluid other than the manufacturer recommended fluid may cause deterioration in transmission shift quality and/or torque converter shudder ➞ page 207.

### Special Additives

The manufacturer strongly recommends against using any special additives in the transmission. Automatic Transmission Fluid (ATF) is an engineered product and its performance may be impaired by supplemental additives. Therefore, do not add any fluid additives to the transmission. The only exception to this policy is the use of special dyes for diagnosing fluid leaks in 9-speed transmissions. Avoid using transmission sealers as they may adversely affect seals.

#### CAUTION!

Do not use chemical flushes in your transmission as the chemicals can damage your transmission components. Such damage is not covered by the New Vehicle Limited Warranty.

### Fluid Level Check

The fluid level is preset at the factory and does not require adjustment under normal operating conditions. Routine fluid level checks are not required, therefore the transmission filler tube is capped and no dipstick is provided. An authorized dealer can check your transmission fluid level using a special service dipstick. If you notice fluid leakage or transmission malfunction, visit an authorized dealer immediately to have the transmission fluid level checked. Operating the vehicle with an improper fluid level can cause severe transmission damage.

#### CAUTION!

If a transmission fluid leak occurs, visit an authorized dealer immediately. Severe transmission damage may occur. An authorized dealer has the proper tools to adjust the fluid level accurately.

### Fluid And Filter Changes

Under normal operating conditions, the fluid installed at the factory will provide satisfactory lubrication for the life of the vehicle.

Routine fluid and filter changes are not required. However, change the fluid and filter if the fluid becomes

contaminated (with water, etc.), or if the transmission is disassembled for any reason.

## FUSES

The fuses protect electrical systems against excessive current.

When a device does not work, you must check the fuse element inside the blade fuse for a break/melt.

Also, please be aware that using power outlets for extended periods of time with the engine off may result in vehicle battery discharge.

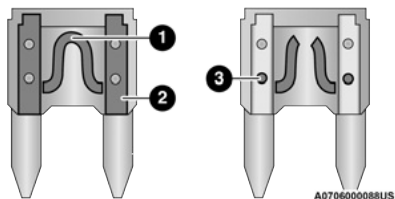

Blade Fuses

- 1 – Fuse Element
- 2 – Blade Fuse with a good/functional fuse element
- 3 – Blade Fuse with a bad/not functional fuse element (blown fuse)

### WARNING!

- When replacing a blown fuse, always use an appropriate replacement fuse with the same amp rating as the original fuse. Never replace a fuse with another fuse of higher amp rating. Never replace a blown fuse with metal wires or any other material. Do not place a fuse inside a circuit breaker cavity or vice versa. Failure to use proper fuses may result in serious personal injury, fire and/or property damage.
- Before replacing a fuse, make sure that the ignition is off and that all the other services are switched off and/or disengaged.
- If the replaced fuse blows again, contact an authorized dealer.
- If a general protection fuse for safety systems (air bag system, braking system), power unit systems, (engine system, transmission system) steering

(Continued)

### WARNING!

system or Body Control Module (BCM) blows, contact an authorized dealer.

## Interior Fuses

The interior fuse panel is part of the Body Control Module (BCM) and is located on the driver's side under the instrument panel.

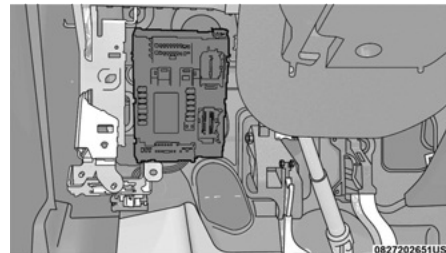

Fuse Panel

Vehicle Fuse Number	Mini Fuse	Description
F31	7.5 Amp	KL15A Power Electric Bay (PEB), HVAC Blower
F36	15 Amp	HVAC, Radio-Display, USB, EOBD, EPB LED
F37	10 Amp	KL15 Instrument Panel Cluster (IPC), Front Radar
F38	15 Amp	Trunk Unlock
F42	7.5 Amp	KL15 Electric Power Steering (EPS), Braking System Module (BSM)
F43	20 Amp	Bi-Directional Washer Pump

Vehicle Fuse Number	Mini Fuse	Description
F47	20 Amp	Driver Window
F48	20 Amp	Passenger Window
F49	7.5 Amp	KL15 Parking AID Module (PAM), Humidity-Rain-Light Sensor, Auto-Dimming Inside Rear View Mirror - If Equipped, USB Charge Outlet, Wireless Charging Pad Module, HVAC Control Panel Module
F50	7.5 Amp	Airbag
F51	7.5 Amp	KL15 Power Electric Bay (PEB), Rear Window Defrost, Heated Mirrors - If Equipped, HVAC, Left Stack Switch
F53	7.5 Amp	Instrument Panel Cluster (IPC), USB Charge Outlet, Telematic Box Module (TBM), Control Panel in the Tunnel Area
F94	15 Amp	12V Power Outlet

### Power Distribution Center #1

The Power Distribution Center #1 is located in the underhood compartment. To access the fuses, remove locking screw and slide cover off.

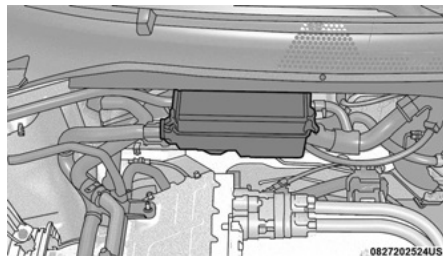

Front Distribution Unit

The ID number of the electrical component corresponding to each fuse can be found on the back of the cover.

Vehicle Fuse Number	Fuse	Description
F01	70 Amp	Body Control Module (BCM1)

Vehicle Fuse Number	Fuse	Description
F02	60 Amp	Body Control Module (BCM2)
F03	20 Amp	Ignition Switch for Body Computer Module (BCM)
F04	40 Amp	Brake System Module Valves
F05	70 Amp	Electric Power Steering (EPS)
F06	50 Amp	MCO Supply
F07	50 Amp	MCO Supply
F08	40 Amp	MCO Supply
F09	15 Amp	Battery Coolant Heater (BCH)
F10	10 Amp	Horn
F14	15 Amp	Power Electric Coolant Pump (PECP)
F15	70 Amp	BSM Pump
F18	15 Amp	Battery Coolant Pump (BCP)
F19	7.5 Amp	EAC and PWM Fan Enable
F20	15 amp	Electric Air Heater (EAH)
F21	5 Amp	Coolant Proportional Valve (CPV)
F23	20 Amp	Heated Seats - If Equipped
F30	20 Amp	Windshield Heater - If Equipped
F83	40 Amp	HVAC Blower
F88	7.5 Amp	Heated Mirrors - If Equipped
F89	20 Amp	Rear Window Defrost
F90	5 Amp	Intelligent Battery Sensor (IBS)

The ID number of the electrical component corresponding to each relay can be found on the back of the cover.

Vehicle Relay Number	Relay	Description
T07	50 Amp	MCO Supply
T17	30 Amp	Rear Window Defrost - Heated Mirrors

## Power Distribution Center #2

The Power Distribution Center #2 is located on top of the battery in the underhood compartment. To access the fuses, pull the release tabs and remove the cover.

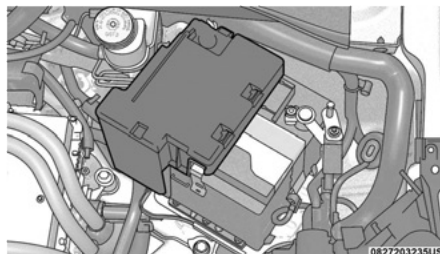

**PDC #2**

Vehicle Fuse Number	Mini Fuse	Description
F01	5 Amp	PEB_1
F02	10 Amp	E-Latch Driver
F03	5 Amp	PEB_2
F04	5 Amp	Electronic Shifter (ESM)
F05	20 Amp	PEB_6
F06	5 Amp	IDCM
F07	20 Amp	PEB_4
F08	20 Amp	PEB_3
F09	10 Amp	E-Latch Passenger
F10	20 Amp	PEB_5
F12	15 Amp	AMPLI Hi-Fi - If Equipped
F14	10 Amp	Battery Pack (BPCM)
F16	5 Amp	Charge Port (CPIM)
F17	20 Amp	PEB_7
F18	5 Amp	Pedestrian (QVPM)
F19	15 Amp	AMPLI Hi-Fi - If Equipped

Vehicle Relay Number	Relay	Description
T02	30 Amp	Heated Seats - If Equipped

T03	20 Amp	Horn
T05	20 Amp	EAC and PWM Fan Enable
T06	30 Amp	Heated Seats - If Equipped
T08	30 Amp	HVAC Fan
T10	30 Amp	Electrical Air Heater (EAH)
T31	20 Amp	Coolant Proportional Valve (CPV)
T89	30 Amp	Battery Coolant Heater (BCH)
T90	30 Amp	Windshield Heater - If Equipped

## BULB REPLACEMENT

### Replacement Bulbs

In the instance a bulb needs to be replaced, this section includes bulb description and replacement part numbers.

#### NOTE:

See an authorized dealer for LED bulb replacement.

#### Interior Bulbs

	Bulb Number
Overhead Lamp	LED (See authorized dealer)
Courtesy Lamp	LED (See authorized dealer)
Rear Cargo Lamps	W5W

#### Exterior Bulbs

	Bulb Number
Front Low and High Beam Headlamp	LED (See authorized dealer)
Front Parking/Daytime Running Lamps	LED (See authorized dealer)
Front Side Marker Lamps	LED (See authorized dealer)
Front Turn Signal Lamps	LED (See authorized dealer)
Side Direction Lamps	LED (See authorized dealer)
Rear Turn Signal Lamps	LED (See authorized dealer)
Rear Side Marker Lamps	LED (See authorized dealer)



	<b>Bulb Number</b>
Rear Tail and Stop Lamps	LED (See authorized dealer)
Rear Backup Lamps	LED (See authorized dealer)
Center High Mounted Stop Lamp	LED (See authorized dealer)
License Plate Lamps	LED (See authorized dealer)

**NOTE:**

Numbers refer to commercial bulb types that can be purchased from an authorized dealer.

If a bulb needs to be replaced, visit an authorized dealer or refer to the applicable Service Manual.

## Replacing Interior Bulbs

### REAR CARGO LAMP

- Using the screwdriver, extract the ceiling light working in the point shown by the arrow.

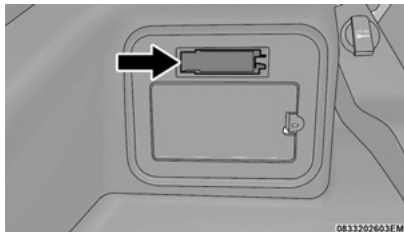

Ceiling Light

- Open the protection and replace the snap-fitted bulb.

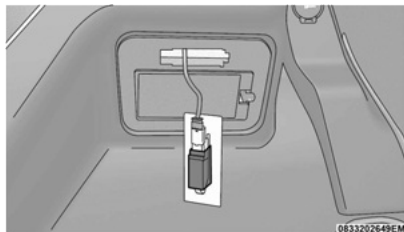

Bulb Replacement

- Close the cover on the lens.
- Refit the ceiling light by inserting it correctly in its housing, on one side and then pressing on the other side until it clicks into place.

## TIRES

### TIRE SAFETY INFORMATION

Tire safety information will cover aspects of the following information: Tire Markings, Tire Identification Numbers, Tire Terminology and Definitions, Tire Pressures, and Tire Loading.

### Tire Markings

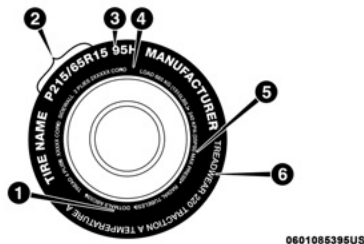

### Tire Markings

- |  |  |
|--|--|
| 1 – U.S. DOT Safety Standards Code (TIN) | 4 – Maximum Load                               |
| 2 – Size Designation                     | 5 – Maximum Pressure                           |
| 3 – Service Description                  | 6 – Treadwear, Traction and Temperature Grades |

### NOTE:

- P (Passenger) – Metric tire sizing is based on U.S. design standards. P-Metric tires have the letter “P” molded into the sidewall preceding the size designation. Example: P215/65R15 95H.
- European – Metric tire sizing is based on European design standards. Tires designed to this standard have the tire size molded into the sidewall beginning with the section width. The letter “P” is absent from this tire size designation. Example: 215/65R15 96H.
- LT (Light Truck) – Metric tire sizing is based on U.S. design standards. The size designation for LT-Metric tires is the same as for P-Metric tires except for the letters “LT” that are molded into the sidewall preceding the size designation. Example: LT235/85R16.
- Temporary spare tires are designed for temporary emergency use only. Temporary high pressure compact spare tires have the letter “T” or “S” molded into the sidewall preceding the size designation. Example: T145/80D18 103M.
- High flotation tire sizing is based on U.S. design standards and it begins with the tire diameter molded into the sidewall. Example: 31x10.5 R15 LT.

## Tire Identification Number (TIN)

The TIN may be found on one or both sides of the tire; however, the date code may only be on one side. Tires with white sidewalls will have the full TIN, including the date code, located on the white sidewall side of the tire. Look for the TIN on the outboard side of black sidewall tires as mounted on the vehicle. If the TIN is not found on the outboard side, then you will find it on the inboard side of the tire.

### EXAMPLE:

DOT MA L9 ABCD 0301

**DOT** = Department of Transportation

- This symbol certifies that the tire is in compliance with the U.S. Department of Transportation tire safety standards and is approved for highway use

**MA** = Code representing the tire manufacturing location (two digits)

**L9** = Code representing the tire size (two digits)

**ABCD** = Code used by the tire manufacturer (one to four digits)

**03** = Number representing the week in which the tire was manufactured (two digits)

- 03 means the 3rd week

**01** = Number representing the year in which the tire was manufactured (two digits)

- 01 means the year 2001

- Prior to July 2000, tire manufacturers were only required to have one number to represent the year in which the tire was manufactured. Example: 031 could represent the 3rd week of 1981 or 1991

## Tire Terminology And Definitions

Term	Definition
<b>B-Pillar</b>	The vehicle B-Pillar is the structural member of the body located behind the front door.
<b>Cold Tire Inflation Pressure</b>	Cold tire inflation pressure is defined as the tire pressure after the vehicle has not been driven for at least three hours, or driven less than 1 mile (1.6 km) after sitting for a minimum of three hours. Inflation pressure is measured in units of PSI (pounds per square inch) or kPa (kilopascals).
<b>Maximum Inflation Pressure</b>	The maximum inflation pressure is the maximum permissible cold tire inflation pressure for this tire. The maximum inflation pressure is molded into the sidewall.
<b>Recommended Cold Tire Inflation Pressure</b>	Vehicle manufacturer's recommended cold tire inflation pressure as shown on the tire placard.
<b>Tire Placard</b>	A label permanently attached to the vehicle describing the vehicle's loading capacity, the original equipment tire sizes and the recommended cold tire inflation pressures.

## Tire Loading And Tire Pressure

**NOTE:**

The proper cold tire inflation pressure is listed on the driver's side B-Pillar or the rear edge of the driver's side door.

Check the inflation pressure of each tire, including the spare tire (if equipped), at least monthly and inflate to the recommended pressure for your vehicle.

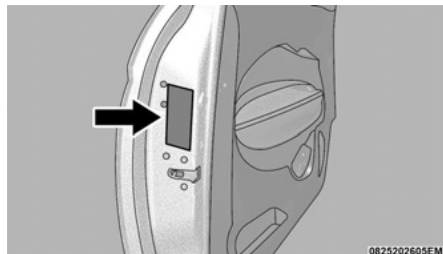

Example Tire Placard Location (Door)

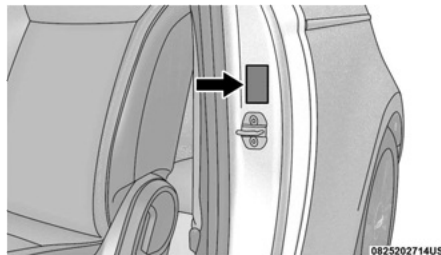

Example Tire Placard Location (B-Pillar)

## Tire And Loading Information Placard

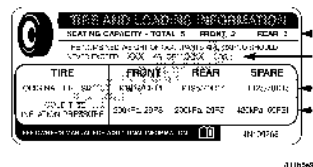

## Tire And Loading Information Placard

This placard tells you important information about the:

1. Number of people that can be carried in the vehicle.
2. Total weight your vehicle can carry.
3. Tire size designed for your vehicle.
4. Cold tire inflation pressures for the front, rear, and spare tires.

## Loading

The vehicle maximum load on the tire must not exceed the load carrying capacity of the tire on your vehicle. You will not exceed the tire's load carrying capacity if you adhere to the loading conditions, tire size, and cold tire inflation pressures specified on the Tire and Loading Information placard in "Vehicle Loading" in the "Starting And Operating" section of this manual.

The vehicle maximum load on the tire must not exceed the load carrying capacity of the tire on your vehicle. You will not exceed the tire's load carrying capacity if you adhere to the loading conditions, tire size, and cold tire inflation pressures specified on the Tire and Loading Information placard in "Vehicle Loading" in the "Starting And Operating" section of this manual.

### NOTE:

Under a maximum loaded vehicle condition, gross axle weight ratings (GAWRs) for the front and rear axles must not be exceeded.

For further information on GAWRs, vehicle loading, and trailer towing, refer to "Vehicle Loading" in the "Starting And Operating" section of this manual.

To determine the maximum loading conditions of your vehicle, locate the statement "The combined weight of

occupants and cargo should never exceed XXX kg or XXX lbs" on the Tire and Loading Information placard. The combined weight of occupants, cargo/luggage and trailer tongue weight (if applicable) should never exceed the weight referenced here.

### Steps For Determining Correct Load Limit—

- (1) Locate the statement "The combined weight of occupants and cargo should never exceed XXX kg or XXX lbs." on your vehicle's placard.
- (2) Determine the combined weight of the driver and passengers that will be riding in your vehicle.
- (3) Subtract the combined weight of the driver and passengers from XXX kg or XXX lbs.
- (4) The resulting figure equals the available amount of cargo and luggage load capacity. For example, if "XXX" amount equals 1400 lbs. and there will be five 150 lb passengers in your vehicle, the amount of available cargo and luggage load capacity is 650 lbs. (1400-750 (5x150) = 650 lbs.)
- (5) Determine the combined weight of luggage and cargo being loaded on the vehicle. That weight may not safely exceed the available cargo and luggage load capacity calculated in Step 4.

(6) If your vehicle will be towing a trailer, load from your trailer will be transferred to your vehicle. Consult this manual to determine how this reduces the available cargo and luggage load capacity of your vehicle.

### Metric Example For Load Limit

For example, if "XXX" amount equals 635 kg and there will be five 68 kg passengers in your vehicle, the amount of available cargo and luggage load capacity is 295 kg (635-340 (5x68) = 295 kg) as shown in step 4.

### NOTE:

- If your vehicle will be towing a trailer, load from your trailer will be transferred to your vehicle. The following table shows examples on how to calculate total load, cargo/luggage, and towing capacities of your vehicle with varying seating configurations and number and size of occupants. This table is for illustration purposes only and may not be accurate for the seating and load carry capacity of your vehicle.
- For the following example, the combined weight of occupants and cargo should never exceed 865 lbs (392 kg).

Occupants			Combined weight of occupants and cargo from Tire Placard	MINUS	Combined Occupant's weight	=	AVAILABLE Cargo/Luggage and Trailer Tongue Weight
TOTAL	FRONT	REAR					
<b>EXAMPLE 1</b>							
5	2	3	865 lbs	minus	Occupant 1: 200 lbs Occupant 2: 130 lbs Occupant 3: 160 lbs Occupant 4: 100 lbs Occupant 5: 80 lbs TOTAL WEIGHT: 670 lbs	=	195 lbs
<b>EXAMPLE 2</b>							
3	2	1	865 lbs	minus	Occupant 1: 210 lbs Occupant 2: 180 lbs Occupant 3: 150 lbs TOTAL WEIGHT: 540 lbs	=	325 lbs
<b>EXAMPLE 3</b>							
2	2	0	865 lbs	minus	Occupant 1: 200 lbs Occupant 2: 200 lbs TOTAL WEIGHT: 400 lbs	=	465 lbs

EXAMPLE

**WARNING!**

Overloading of your tires is dangerous. Overloading can cause tire failure, affect vehicle handling, and increase your stopping distance. Use tires of the recommended load capacity for your vehicle. Never overload them.

### TIRES — GENERAL INFORMATION

#### Tire Pressure

Proper tire inflation pressure is essential to the safe and satisfactory operation of your vehicle. Four primary areas are affected by improper tire pressure:

- Safety
- Fuel Economy

- Tread Wear
- Ride Comfort and Vehicle Stability

**Safety**

**WARNING!**

- Improperly inflated tires are dangerous and can cause collisions.

*(Continued)*

**WARNING!**

- Underinflation increases tire flexing and can result in overheating and tire failure.
- Overinflation reduces a tire's ability to cushion shock. Objects on the road and chuckholes can cause damage that result in tire failure.
- Overinflated or underinflated tires can affect vehicle handling and can fail suddenly, resulting in loss of vehicle control.
- Unequal tire pressures can cause steering problems. You could lose control of your vehicle.
- Unequal tire pressures from one side of the vehicle to the other can cause the vehicle to drift to the right or left.
- Always drive with each tire inflated to the recommended cold tire inflation pressure.

Both under-inflation and over-inflation affect the stability of the vehicle and can produce a feeling of sluggish response or over responsiveness in the steering.

**NOTE:**

- Unequal tire pressures from side to side may cause erratic and unpredictable steering response.
- Unequal tire pressure from side to side may cause the vehicle to drift left or right.

**Battery Economy**

Underinflated tires will increase tire rolling resistance resulting in higher battery charge consumption.

**Tread Wear**

Improper cold tire inflation pressures can cause abnormal wear patterns and reduced tread life, resulting in the need for earlier tire replacement.

**Ride Comfort And Vehicle Stability**

Proper tire inflation contributes to a comfortable ride. Over-inflation produces a jarring and uncomfortable ride.

**Tire Inflation Pressures**

The proper cold tire inflation pressure is listed on the driver's side B-Pillar or rear edge of the driver's side door.

At least once a month:

- Check and adjust tire pressure with a good quality pocket-type pressure gauge. Do not make a visual judgement when determining proper inflation. Tires may look properly inflated even when they are under-inflated.
- Inspect tires for signs of tire wear or visible damage.

**CAUTION!**

After inspecting or adjusting the tire pressure, always reinstall the valve stem cap. This will prevent moisture and dirt from entering the valve stem, which could damage the valve stem.

Inflation pressures specified on the placard are always "cold tire inflation pressure". Cold tire inflation pressure is defined as the tire pressure after the vehicle has not

been driven for at least three hours, or driven less than 1 mile (1.6 km) after sitting for a minimum of three hours. The cold tire inflation pressure must not exceed the maximum inflation pressure molded into the tire sidewall.

Check tire pressures more often if subject to a wide range of outdoor temperatures, as tire pressures vary with temperature changes.

Tire pressures change by approximately 1 psi (7 kPa) per 12°F (7°C) of air temperature change. Keep this in mind when checking tire pressure inside a garage, especially in the Winter.

Example: If garage temperature = 68°F (20°C) and the outside temperature = 32°F (0°C) then the cold tire inflation pressure should be increased by 3 psi (21 kPa), which equals 1 psi (7 kPa) for every 12°F (7°C) for this outside temperature condition.

Tire pressure may increase from 2 to 6 psi (13 to 40 kPa) during operation. DO NOT reduce this normal pressure build up or your tire pressure will be too low.

**Tire Pressures For High Speed Operation**

The manufacturer advocates driving at safe speeds and within posted speed limits. Where speed limits or conditions are such that the vehicle can be driven at high speeds, maintaining correct tire inflation pressure is very important. Increased tire pressure and reduced vehicle loading may be required for high-speed vehicle operation. Refer to an authorized tire dealer or original equipment vehicle dealer for recommended safe operating speeds, loading and cold tire inflation pressures.

**WARNING!**

High speed driving with your vehicle under maximum load is dangerous. The added strain on your tires could cause them to fail. You could have a serious collision. Do not drive a vehicle loaded to the maximum capacity at continuous speeds above 75 mph (120 km/h).

**Radial Ply Tires****WARNING!**

Combining radial ply tires with other types of tires on your vehicle will cause your vehicle to handle poorly. The instability could cause a collision. Always use radial ply tires in sets of four. Never combine them with other types of tires.

**Tire Repair**

If your tire becomes damaged, it may be repaired if it meets the following criteria:

- The tire has not been driven on when flat.
- The damage is only on the tread section of your tire (sidewall damage is not repairable).
- The puncture is no greater than a ¼ of an inch (6 mm).

Consult an authorized tire dealer for tire repairs and additional information.

Damaged Run Flat tires, or Run Flat tires that have experienced a loss of pressure should be replaced immediately with another Run Flat tire of identical size and service description (Load Index and Speed

Symbol). Replace the tire pressure sensor as well as it is not designed to be reused.

**Run Flat Tires – If Equipped**

Run Flat tires allow you the capability to drive 50 miles (80 km) at 50 mph (80 km/h) after a rapid loss of inflation pressure. This rapid loss of inflation is referred to as the Run Flat mode. A Run Flat mode occurs when the tire inflation pressure is of/or below 14 psi (96 kPa). Once a Run Flat tire reaches the run flat mode it has limited driving capabilities and needs to be replaced immediately. A Run Flat tire is not repairable. When a run flat tire is changed after driving with underinflated tire condition, please replace the TPM sensor as it is not designed to be reused when driven under run flat mode (14 psi (96 kPa)) condition.

**NOTE:**

TPM Sensor must be replaced after driving the vehicle on a flat tire condition.

It is not recommended driving a vehicle loaded at full capacity or to tow a trailer while a tire is in the run flat mode.

See the tire pressure monitoring section for more information.

**Tire Spinning**

When stuck in mud, sand, snow, or ice conditions, do not spin your vehicle's wheels above 30 mph (48 km/h) or for longer than 30 seconds continuously without stopping.

Refer to “Freeing A Stuck Vehicle” in “In Case Of Emergency” for further information.

**WARNING!**

Fast spinning tires can be dangerous. Forces generated by excessive wheel speeds may cause tire damage or failure. A tire could explode and injure someone. Do not spin your vehicle's wheels faster than 30 mph (48 km/h) for more than 30 seconds continuously when you are stuck, and do not let anyone near a spinning wheel, no matter what the speed.

**Tread Wear Indicators**

Tread wear indicators are in the original equipment tires to help you in determining when your tires should be replaced.

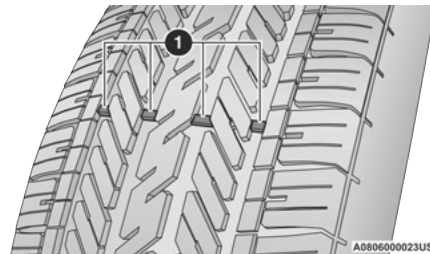
**Tire Tread****1 – Tread Wear Indicators**

These indicators are molded into the bottom of the tread grooves. They will appear as bands when the tread depth becomes a 1/16 of an inch (1.6 mm).



When the tread is worn to the tread wear indicators, the tire should be replaced.

## Life Of Tire

The service life of a tire is dependent upon varying factors including, but not limited to:

- Driving style.
- Tire pressure - Improper cold tire inflation pressures can cause uneven wear patterns to develop across the tire tread. These abnormal wear patterns will reduce tread life, resulting in the need for earlier tire replacement.
- Distance driven.
- Performance tires, tires with a speed rating of V or higher, and Summer tires typically have a reduced tread life. Rotation of these tires per the vehicle scheduled maintenance is highly recommended.

### WARNING!

Tires and the spare tire should be replaced after three years, regardless of the remaining tread. Failure to follow this warning can result in sudden tire failure. You could lose control and have a collision resulting in serious injury or death.

### NOTE:

Wheel Valve Stem must be replaced as well when installing new tires due to wear and tear in existing tires.

Keep dismantled tires in a cool, dry place with as little exposure to light as possible. Protect tires from contact with oil, grease, and gasoline.

## Replacement Tires

The tires on your new vehicle provide a balance of many characteristics. They should be inspected regularly for wear and correct cold tire inflation pressures. The manufacturer strongly recommends using tires equivalent to the originals in size, quality and performance when replacement is needed ➡ page 198. Refer to the Tire And Loading Information Placard or the Vehicle Certification Label for the size designation of your tire. The Load Index and Speed Symbol for your tire will be found on the original equipment tire sidewall.

For more information relating to the Load Index and Speed Symbol of a tire ➡ page 192.

It is recommended to replace the two front tires or two rear tires as a pair. Replacing just one tire can seriously affect your vehicle's handling. If you ever replace a wheel, make sure that the wheel's specifications match those of the original wheels.

It is recommended you contact an authorized tire dealer or original equipment dealer with any questions you may have on tire specifications or capability. Failure to use equivalent replacement tires may adversely affect the safety, handling, and ride of your vehicle.

### WARNING!

- Do not use a tire, wheel size, load rating, or speed rating other than that specified for your vehicle. Some combinations of unapproved tires and wheels may change suspension dimensions and performance characteristics, resulting in changes

*(Continued)*

### WARNING!

to steering, handling, and braking of your vehicle. This can cause unpredictable handling and stress to steering and suspension components. You could lose control and have a collision resulting in serious injury or death. Use only the tire and wheel sizes with load ratings approved for your vehicle.

- Never use a tire with a smaller load index or capacity, other than what was originally equipped on your vehicle. Using a tire with a smaller load index could result in tire overloading and failure. You could lose control and have a collision.
- Failure to equip your vehicle with tires having adequate speed capability can result in sudden tire failure and loss of vehicle control.

### CAUTION!

Replacing original tires with tires of a different size may result in false speedometer and odometer readings.

## TIRE TYPES

### All Season Tires – If Equipped

All Season tires provide traction for all seasons (Spring, Summer, Fall, and Winter). Traction levels may vary between different all season tires. All season tires can be identified by the M+S, M&S, M/S or MS designation on the tire sidewall. Use all season tires only in sets of four; failure to do so may adversely affect the safety and handling of your vehicle.

## Summer Or Three Season Tires — If Equipped

Summer tires provide traction in both wet and dry conditions, and are not intended to be driven in snow or on ice. If your vehicle is equipped with Summer tires, be aware these tires are not designed for Winter or cold driving conditions. Install Winter tires on your vehicle when ambient temperatures are less than 40°F (5°C) or if roads are covered with ice or snow. For more information, contact an authorized dealer.

Summer tires do not contain the all season designation or mountain/snowflake symbol on the tire sidewall. Use Summer tires only in sets of four; failure to do so may adversely affect the safety and handling of your vehicle.

### WARNING!

Do not use Summer tires in snow/ice conditions. You could lose vehicle control, resulting in severe injury or death. Driving too fast for conditions also creates the possibility of loss of vehicle control. We strongly recommend using All Season tires during the winter season or in cold climate regions.

## Snow Tires



Some areas of the country require the use of snow tires during the Winter. Snow tires can be identified by a mountain/snowflake symbol on the tire sidewall.

If you need snow tires, select tires equivalent in size and type to the original equipment tires. Use snow tires only in sets of four; failure to do so may adversely affect the safety and handling of your vehicle.

Snow tires generally have lower speed ratings than what was originally equipped with your vehicle and should not be operated at sustained speeds over 75 mph (120 km/h). For speeds above 75 mph (120 km/h) refer to original equipment or an authorized tire dealer for recommended safe operating speeds, loading and cold tire inflation pressures.

While studded tires improve performance on ice, skid and traction capability on wet or dry surfaces may be poorer than that of non-studded tires. Some states prohibit studded tires; therefore, local laws should be checked before using these tire types.

## WHEEL AND WHEEL TRIM CARE

All wheels and wheel trim, especially aluminum and chrome plated wheels, should be cleaned regularly using mild (neutral Ph) soap and water to maintain their luster and to prevent corrosion. Wash wheels with the same soap solution recommended for the body of the vehicle and remember to always wash when the surfaces are not hot to the touch.

Your wheels are susceptible to deterioration caused by salt, sodium chloride, magnesium chloride, calcium chloride, etc., and other road chemicals used to melt ice or control dust on dirt roads. Use a soft cloth or sponge and mild soap to wipe away promptly. Do not use harsh chemicals or a stiff brush. They can damage the wheel's protective coating that helps keep them from corroding and tarnishing.

### CAUTION!

Avoid products or automatic car washes that use acidic solutions or strong alkaline additives or harsh brushes. Many aftermarket wheel cleaners and automatic car washes may damage the wheel's protective finish. Such damage is not covered by the New Vehicle Limited Warranty. Only car wash soap, Mopar Wheel Cleaner or equivalent is recommended.

When cleaning extremely dirty wheels including excessive brake dust, care must be taken in the selection of tire and wheel cleaning chemicals and equipment to prevent damage to the wheels. Mopar Wheel Treatment or Mopar Chrome Cleaner or their equivalent is recommended or select a non-abrasive, non-acidic cleaner for aluminum or chrome wheels.

### CAUTION!

Do not use scouring pads, steel wool, a bristle brush, metal polishes or oven cleaner. These products may damage the wheel's protective finish. Such damage is not covered by the New Vehicle Limited Warranty. Only car wash soap, Mopar Wheel Cleaner or equivalent is recommended.

### NOTE:

If you intend parking or storing your vehicle for an extended period after cleaning the wheels with wheel cleaner, drive your vehicle and apply the brakes to remove the water droplets from the brake components. This activity will remove the red rust on the brake rotors and prevent vehicle vibration when braking.

**Dark Vapor Chrome, Black Satin Chrome, or Low Gloss Clear Coat Wheels****CAUTION!**

If your vehicle is equipped with these specialty wheels, DO NOT USE wheel cleaners, abrasives, or polishing compounds. They will permanently damage this finish and such damage is not covered by the New Vehicle Limited Warranty. HAND WASH ONLY USING MILD SOAP AND WATER WITH A SOFT CLOTH. Used on a regular basis; this is all that is required to maintain this finish.

**TIRE CHAINS (TRACTION DEVICES)**

Due to limited clearance, tire chains or traction devices are not recommended.

**CAUTION!**

Damage to the vehicle may result if tire chains are used.

**TIRE ROTATION RECOMMENDATIONS**

The tires on the front and rear of your vehicle operate at different loads and perform different steering, handling, and braking functions. For these reasons, they wear at unequal rates.

These effects can be reduced by timely rotation of tires. The benefits of rotation are especially worthwhile with aggressive tread designs such as those on On/Off Road type tires. Rotation will increase tread life, help to maintain mud, snow, and wet traction levels, and contribute to a smooth, quiet ride.

For the proper maintenance intervals ⇨ page 178. The reasons for any rapid or unusual wear should be corrected prior to rotation being performed.

The suggested rotation method is the "forward cross" shown in the following diagram. This rotation pattern does not apply to some directional tires that must not be reversed.

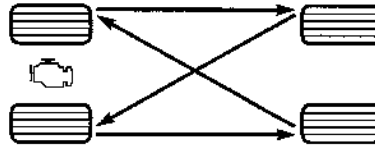

055707139

**Tire Rotation (Forward Cross)****DEPARTMENT OF TRANSPORTATION  
UNIFORM TIRE QUALITY GRADES**

The following tire grading categories were established by the National Highway Traffic Safety Administration. The specific grade rating assigned by the tire's manufacturer in each category is shown on the sidewall of the tires on your vehicle.

All passenger vehicle tires must conform to Federal safety requirements in addition to these grades.

**TREADWEAR**

The Treadwear grade is a comparative rating, based on the wear rate of the tire when tested under controlled conditions on a specified government test course. For example, a tire graded 150 would wear one and one-half times as well on the government course as a tire graded 100. The relative performance of tires depends upon the actual conditions of their use, however, and may depart significantly from the norm due to variations in driving habits, service practices, and differences in road characteristics and climate.

**TRACTION GRADES**

The Traction grades, from highest to lowest, are AA, A, B, and C. These grades represent the tire's ability to stop on wet pavement, as measured under controlled conditions on specified government test surfaces of asphalt and concrete. A tire marked C may have poor traction performance.

**WARNING!**

The traction grade assigned to this tire is based on straight-ahead braking traction tests, and does not include acceleration, cornering, hydroplaning, or peak traction characteristics.

**TEMPERATURE GRADES**

The Temperature grades are A (the highest), B, and C, representing the tire's resistance to the generation of heat and its ability to dissipate heat, when tested under controlled conditions on a specified indoor laboratory test wheel.

Sustained high temperature can cause the material of the tire to degenerate and reduce tire life, and excessive temperature can lead to sudden tire failure. The grade C corresponds to a level of performance, which all passenger vehicle tires must meet under the Federal Motor Vehicle Safety Standard No. 109. Grades B and A represent higher levels of performance on the laboratory test wheel, than the minimum required by law.

The Temperature grades are A (the highest), B, and C, representing the tire's resistance to the generation of heat and its ability to dissipate heat, when tested under controlled conditions on a specified indoor laboratory test wheel.

Sustained high temperature can cause the material of the tire to degenerate and reduce tire life, and excessive temperature can lead to sudden tire failure. The grade C corresponds to a level of performance, which all passenger vehicle tires must meet under the Federal Motor Vehicle Safety Standard No. 109. Grades B and A represent higher levels of performance on the laboratory test wheel, than the minimum required by law.

#### WARNING!

The temperature grade for this tire is established for a tire that is properly inflated and not overloaded. Excessive speed, under-inflation, or excessive loading, either separately or in combination, can cause heat buildup and possible tire failure.

## STORING THE VEHICLE

If you are storing your vehicle for more than 3 weeks, we recommend that you take the following steps to minimize the drain on your vehicle's battery:

- Disconnect the negative cable from the battery.
- Any time you store your vehicle or keep it out of service (i.e., vacation) for two weeks or more, run the air conditioning system at idle for about five minutes in the fresh air and high blower setting prior to storing. This will ensure adequate system lubrication to minimize the possibility of compressor damage when the system is started again.

#### WARNING!

Leaving your vehicle for over 30 days where the lithium-ion battery reaches a zero or near zero state of charge could cause damage to the high voltage battery.

## BODYWORK

### PROTECTION FROM ATMOSPHERIC AGENTS

Vehicle body care requirements vary according to geographic locations and usage. Chemicals that make roads passable in snow and ice and those that are sprayed on trees and road surfaces during other seasons are highly corrosive to the metal in your vehicle. Outside parking, which exposes your vehicle to airborne contaminants, road surfaces on which the vehicle is operated, extreme hot or cold weather, and

other extreme conditions will have an adverse affect on paint, metal trim, and underbody protection.

The following maintenance recommendations will enable you to obtain maximum benefit from the corrosion resistance built into your vehicle.

### What Causes Corrosion?

Corrosion is the result of deterioration or removal of paint and protective coatings from your vehicle.

The most common causes are:

- Road salt, dirt and moisture accumulation
- Stone and gravel impact
- Insects, tree sap and tar
- Salt in the air near seacoast localities
- Atmospheric fallout/industrial pollutants

## BODY AND UNDERBODY MAINTENANCE

### Cleaning Headlights

Your vehicle is equipped with plastic headlights and fog lights that are lighter and less susceptible to stone breakage than glass headlights.

Plastic is not as scratch resistant as glass and therefore different lens cleaning procedures must be followed.

To minimize the possibility of scratching the lenses and reducing light output, avoid wiping with a dry cloth. To remove road dirt, wash with a mild soap solution followed by rinsing.

Do not use abrasive cleaning components, solvents, steel wool or other aggressive material to clean the lenses.

## PRESERVING THE BODYWORK

### Washing

- Wash your vehicle regularly. Always wash your vehicle in the shade using Mopar® Car Wash, or a mild car wash soap, and rinse the panels completely with water.
- If insects, tar, or other similar deposits have accumulated on your vehicle, use Mopar® Super Kleen Bug and Tar Remover to remove.
- Use a high quality cleaner wax, such as Mopar® Cleaner Wax to remove road film, stains and to protect your paint finish. Use precautions to not scratch the paint.
- Avoid using abrasive compounds and power buffing that may diminish the gloss or thin out the paint finish.

#### CAUTION!

- Do not use abrasive or strong cleaning materials such as steel wool or scouring powder that will scratch metal and painted surfaces.
- Use of power washers exceeding 1,200 psi (8,274 kPa) can result in damage or removal of paint and decals.

## Special Care

- If you drive on salted or dusty roads or if you drive near the ocean, hose off the undercarriage at least once a month.
- It is important that the drain holes in the lower edges of the doors, rocker panels, and trunk be kept clear and open.
- If you detect any stone chips or scratches in the paint, touch them up immediately.
- If your vehicle is damaged due to a collision or similar cause that destroys the paint and protective coating, have your vehicle repaired as soon as possible.
- If you carry special cargo such as chemicals, fertilizers, de-icer salt, etc., be sure that such materials are well packaged and sealed.
- If a lot of driving is done on gravel roads, consider mud or stone shields behind each wheel.
- Use Mopar® Touch Up Paint on scratches as soon as possible. An authorized dealer has touch up paint to match the color of your vehicle.

## INTERIORS

### SEATS AND FABRIC PARTS

Use Mopar® Total Clean to clean fabric upholstery and carpeting.

#### WARNING!

Do not use volatile solvents for cleaning purposes. Many are potentially flammable, and if used in closed areas they may cause respiratory harm.

### Stain Repel Fabric Cleaning Procedure — If Equipped

Stain Repel seats may be cleaned in the following manner:

- Remove as much of the stain as possible by blotting with a clean, dry towel.
- Blot any remaining stain with a clean, damp towel.
- For tough stains, apply Mopar® Total Clean, or a mild soap solution to a clean, damp cloth and remove stain. Use a fresh, damp towel to remove soap residue.
- For grease stains, apply Mopar® Multi-Purpose Cleaner to a clean, damp cloth and remove stain. Use a fresh, damp towel to remove soap residue.
- Do not use any harsh solvents or any other form of protectants on Stain Repel products.

### Seat Belt Maintenance

Do not bleach, dye or clean the belts with chemical solvents or abrasive cleaners. This will weaken the fabric.

If the belts need cleaning, use a mild soap solution or lukewarm water. Do not remove the belts from the vehicle to wash them. Dry with a soft cloth.

Sun damage can also weaken the fabric. Replace the belts if they appear frayed or worn or if the buckles do not work properly.

#### WARNING!

A frayed or torn seat belt could rip apart in a collision and leave you with no protection. Inspect the seat belt system periodically, checking for cuts, frays, or loose parts. Damaged parts must be replaced immediately. Do not disassemble or modify the seat belt system. If your vehicle is involved in a collision, or if you have questions regarding seat belt or retractor conditions, take your vehicle to an authorized FCA dealer or authorized FCA Certified Collision Care Program facility for inspection.

## PLASTIC AND COATED PARTS

Use Mopar® Total Clean to clean vinyl upholstery.

#### CAUTION!

- Direct contact of air fresheners, insect repellents, suntan lotions, or hand sanitizers to the plastic, painted, or decorated surfaces of the interior may cause permanent damage. Wipe away immediately.
- Damage caused by these type of products may not be covered by your New Vehicle Limited Warranty.

## Cleaning Plastic Instrument Cluster Lenses

The lenses in front of the instruments in this vehicle are molded in clear plastic. When cleaning the lenses, care must be taken to avoid scratching the plastic.

Clean with a wet soft cloth. A mild soap solution may be used, but do not use high alcohol content or abrasive cleaners. If soap is used, wipe clean with a clean damp cloth. Dry with a soft cloth.

## LEATHER SURFACES

Mopar® Total Clean is specifically recommended for leather upholstery.

Your leather upholstery can be best preserved by regular cleaning with a damp soft cloth. Small particles of dirt can act as an abrasive and damage the leather upholstery and should be removed promptly with a damp cloth. Stubborn soils can be removed easily with a soft cloth and Mopar® Total Clean. Care should be taken to avoid soaking your leather upholstery with any liquid. Please do not use polishes, oils, cleaning fluids, solvents, detergents, or ammonia-based cleaners to clean your leather upholstery.

#### NOTE:

If equipped with light colored leather, it tends to show any foreign material, dirt, and fabric dye transfer more so than darker colors. The leather is designed for easy cleaning, and FCA recommends Mopar® total care leather cleaner applied on a cloth to clean the leather seats as needed.

#### CAUTION!

Do not use alcohol and alcohol-based and/or ketone-based cleaning products to clean leather upholstery, as damage to the upholstery may result.

## GLASS SURFACES

All glass surfaces should be cleaned on a regular basis with Mopar® Glass Cleaner, or any commercial household-type glass cleaner. Never use an abrasive type cleaner. Use caution when cleaning the inside rear window equipped with electric defrosters or windows equipped with radio antennas. Do not use scrapers or other sharp instruments that may scratch the elements.

When cleaning the rearview mirror, spray cleaner on the towel or cloth that you are using. Do not spray cleaner directly on the mirror.

# TECHNICAL SPECIFICATIONS

## VEHICLE IDENTIFICATION NUMBER (VIN)

(The label is shown divided into two parts for reading purposes)

It is applied to the left front pillar.

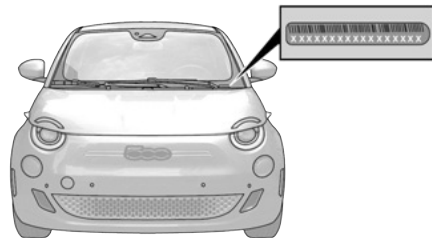

0904202420EM

Vehicle Identification Number

### NOTE:

It is illegal to remove or alter the VIN.

## BRAKE SYSTEM

Your vehicle is equipped with dual hydraulic brake systems. If either of the two hydraulic systems lose normal capability, the remaining system will still function. However, there will be some loss of overall braking effectiveness. You may notice increased pedal travel during application, greater pedal force required

to slow or stop, and potential activation of the Brake System Warning Light.

In the event power assist is lost for any reason (i.e., repeated brake applications with the engine off), the brakes will still function. However, the effort required to brake the vehicle will be much greater than that required with the power system operating.

### CAUTION!

If the Brake System Warning Light remains on with the parking brake released, a brake system malfunction is indicated. Have the brake system serviced by an authorized dealer immediately.

## WHEEL AND TIRE TORQUE SPECIFICATIONS

Proper lug nut/bolt torque is very important to ensure that the wheel is properly mounted to the vehicle. Any time a wheel has been removed and reinstalled on the vehicle, the lug nuts/bolts should be torqued using a properly calibrated torque wrench using a high quality six sided (hex) deep wall socket.

## TORQUE SPECIFICATIONS

Lug Nut/Bolt Torque	**Lug Nut/Bolt Size	Lug Nut/Bolt Socket Size
88.5 Ft-Lbs (120 N-m)	M12 x 1.25	17 mm

\*\*Use only your authorized dealer recommended lug nuts/bolts and clean or remove any dirt or oil before tightening.

Inspect the wheel mounting surface prior to mounting the tire and remove any corrosion or loose particles.

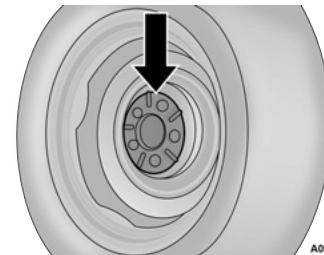

Wheel Mounting Surface

Tighten the lug nuts/bolts in the following pattern until each nut/bolt has been tightened twice.

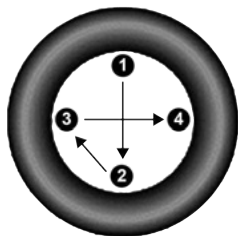

Torque Patterns

0902203259US

After 25 miles (40 km), check the lug nut/bolt torque to be sure that all the lug nuts/bolts are properly seated against the wheel.

**WARNING!**

To avoid the risk of forcing the vehicle off the jack, do not tighten the lug nuts/bolts fully until the vehicle has been lowered. Failure to follow this warning may result in personal injury.

**FLUID CAPACITIES**

Systems	U.S.	Metric
EDM (Electronic Drive Module)	0.18 US gal	0.67 Liters
Cooling system	1.72 US gal	6.5 Liters
Hydraulic brake circuit	1.76 lb	0.8 kg
Windshield and rear window washer fluid reservoir	0.40 US gal	1.5 Litres

**DRIVE TRANSMISSION FLUIDS AND LUBRICANTS**

Component	Fluid, Lubricant, or Genuine Part
Drive Transmission Greases	We recommend using Mopar® Molybdenum disulphide grease, for use at high temperatures. N.L.G.I. consistency 1-2. Specification: 9.55580-GRAS II. We recommend using Mopar® Low friction coefficient grease for constant velocity joints. N.L.G.I. consistency 0-1. Specification: 9.55580-GRAS II.
Drive Transmission Lubricant	We recommend using Mopar® SAE 75W-70, API GL-4. Specification: 9.55550-MZ14.
Drive Transmission Coolant	We recommend using Mopar® Antifreeze/Coolant 10 Year/150,000 Mile (240,000 km) Formula OAT (Organic Additive Technology) meeting the requirements of the manufacturer Material Standard MS.90032.



**CAUTION!**

- Mixing of engine coolant (antifreeze) other than specified Organic Additive Technology (OAT) engine coolant (antifreeze), may result in engine damage and may decrease corrosion protection. Organic Additive Technology (OAT) engine coolant is different and should not be mixed with Hybrid Organic Additive Technology (HOAT) engine coolant (antifreeze) or any "globally compatible" coolant (antifreeze). If a non-OAT engine coolant (antifreeze) is introduced into the cooling system in an emergency, the cooling system will need to be drained, flushed, and refilled with fresh OAT coolant (conforming to MS.90032), by an authorized dealer as soon as possible.
- Do not use water alone or alcohol-based engine coolant (antifreeze) products. Do not use additional rust inhibitors or antirust products, as they may not be compatible with the radiator engine coolant and may plug the radiator.
- This vehicle has not been designed for use with propylene glycol-based engine coolant (antifreeze). Use of propylene glycol-based engine coolant (antifreeze) is not recommended.

**CHASSIS FLUIDS AND LUBRICANTS**

Component	Fluid, Lubricant, Or Genuine Part
Refrigerant	We recommend using Mopar® R1234yf.
Brake Master Cylinder	We recommend using Mopar® DOT 4, ISO 4925, Class 6, SAE J1704. DOT 4 brake fluid must be changed every two years regardless of mileage.
Windshield/Rear Window Washer Fluid	Use only Mopar® Mixture of alcohol, water and surfactants CUNA NC 956-II.

# CUSTOMER ASSISTANCE

## SUGGESTIONS FOR OBTAINING SERVICE FOR YOUR VEHICLE

### PREPARE FOR THE APPOINTMENT

All work to be performed may not be covered by the warranty. Discuss additional charges with the service manager. Keep a maintenance log of your vehicle's service history. This can often provide a clue to the current problem.

### PREPARE A LIST

Make a written list of your vehicle's problems or the specific work you want done. If you've had an accident or work done that is not on your maintenance log, let the service advisor know.

### BE REASONABLE WITH REQUESTS

If you list a number of items and you must have your vehicle by the end of the day, discuss the situation with the service advisor and list the items in order of priority. At many authorized dealers, you may obtain a rental vehicle (additional charges may apply). If you need a rental, it is advisable to make these arrangements when you call for an appointment.

## IF YOU NEED ASSISTANCE

The manufacturer and its authorized dealer are vitally interested in your satisfaction. We want you to be happy with our products and services.

Warranty service must be done by an authorized dealer. We strongly recommend that you take the vehicle to an authorized dealer. They know your vehicle the best, and are most concerned that you get prompt and high quality service. The manufacturer's authorized dealer have the facilities, factory-trained technicians, special tools, and the latest information to ensure the vehicle is fixed correctly and in a timely manner.

This is why you should always talk to an authorized dealer service manager first. Most matters can be resolved with this process.

- If for some reason you are still not satisfied, talk to the general manager or owner of the authorized dealer. They want to know if you need assistance.
- If an authorized dealer is unable to resolve the concern, you may contact the manufacturer's customer center.

Any communication to the manufacturer's customer center should include the following information:

- Owner's name and address

- Owner's telephone number (home and office)
- Authorized dealer name
- Vehicle Identification Number (VIN)
- Vehicle delivery date and mileage

## ROADSIDE ASSISTANCE

Available 24 hours, 7 days a week.

Call 1-888-242-6342 or visit [fiat.rsahelp.com](http://fiat.rsahelp.com) (USA)

Call 1-800-363-4869 or visit [fca.roadsideaid.com](http://fca.roadsideaid.com) (Canada)

### Who is Covered

You are covered by Roadside Assistance services if you are a purchaser for use of the vehicle. Roadside Assistance services last for five years or 60,000 miles on the odometer, whichever occurs first, calculated from the start date of the Basic Limited Warranty, as set forth in the Warranty Information book.<sup>1</sup>

### What to Do

If your vehicle requires jump start assistance, out of gas/fuel delivery, tire service, lockout service or towing as a result of a mechanical breakdown, dial toll-free: USA: 1-888-242-6342/Canada: 1-800-363-4869. Provide your name, Vehicle Identification Number (VIN)

<sup>1</sup> Towing services provided through Cross Country Motor Club, Inc. Medford, MA 02155, except in AK, CA, HI, OR, WI, and WY, where services are provided by Cross Country Motor Club of California, Inc., Thousand Oaks, CA 91360.

required for covered services, license plate number, and your location, including the telephone number from which you are calling. Briefly describe the nature of the problem and answer a few simple questions. You will be given the name of the service provider and an estimated time of arrival. If you feel you are in an unsafe situation, please let us know. With your consent, we will contact local police or safety authorities.

#### **If Unable to Contact Roadside Assistance**

If you are unable to contact Roadside Assistance or unable to provide a valid Vehicle Identification Number (VIN), and you obtain towing services on your own, you may submit your original receipts from the licensed towing or service facility, for services rendered within 30 days of the occurrence. Be sure to include your VIN, odometer mileage at the time of service, and current mailing address. We will process the claim based on vehicle and service eligibility. If eligible, we will reimburse you for the reasonable amount actually paid, based on the usual and customary charges for that service in the area where they were provided. FCA US LLC's determination relating to reimbursement is final. Correspondence should be mailed to:

FCA US LLC Customer Assistance

P.O. Box 9145

Medford, MA 02155

Attention Claims Department

FCA US LLC reserves the right to modify the terms or discontinue the Roadside Assistance Program at any time. The Roadside Assistance program is subject to restrictions and conditions of use, which are determined solely by FCA US LLC.

#### **Flat Tire Service**

If you are inconvenienced by a flat tire, we will dispatch a service provider to use your vehicle's temporary spare tire (if equipped) as recommended in your Owner's Manual. This is not a permanent flat tire repair.

#### **Battery Jump Assistance**

No time is a good time for a depleted battery. With Roadside Assistance, you do not have to worry about being stranded. We will dispatch a service provider to provide you with a battery jump anytime, day or night.

#### **Lockout Service**

Whether the keys are locked in your vehicle or frozen locks are keeping you from getting on your way, help is just a phone call away. This service is limited to providing access to the vehicle's seating area. It does not cover the cost of replacement keys.

#### **Towing Service**

Our towing service gives you peace of mind and confidence. If your vehicle becomes disabled as a result of a mechanical breakdown, Roadside Assistance will dispatch a towing service to transport your vehicle to the closest authorized FIAT® dealer.

### **FCA US LLC CUSTOMER CENTER**

P.O. Box 21-8004

Auburn Hills, MI 48321-8004

Phone: (888) 242-6342

### **FCA CANADA INC. CUSTOMER CENTER**

P.O. Box 1621

Windsor, Ontario N9A 4H6

Phone: (800) 465-2001 English / (800) 387-9983  
French

### **IN MEXICO CONTACT**

Av. Prolongacion Paseo de la Reforma, 1240

Sante Fe C.P. 05109

Mexico, CDMX

In Mexico City: 800-505-1300

Outside Mexico City: +(52)55 50817568

### **PUERTO RICO AND U.S. VIRGIN ISLANDS**

FCA Caribbean LLC

P.O. Box 191857

San Juan 00919-1857

Phone: (888) 242-6342

### **CUSTOMER ASSISTANCE FOR THE HEARING OR SPEECH IMPAIRED (TDD/TTY)**

To assist customers who have hearing difficulties, the manufacturer has installed special TDD (Telecommunication Devices for the Deaf) equipment at its customer center. Any hearing or speech impaired customer, who has access to a TDD or a conventional teletypewriter (TTY) in the United States, can communicate with the manufacturer by dialing 1-800-380-CHRY.

Canadian residents with hearing difficulties that require assistance can use the special needs relay service

offered by Bell Canada. For TTY teletypewriter users, dial 711 and for Voice callers, dial 1-800-855-0511 to connect with a Bell Relay Service operator.

## SERVICE CONTRACT

You may have purchased a service contract for a vehicle to help protect you from the high cost of unexpected repairs after FCA US LLC's New Vehicle Limited Warranty expires. The Mopar® Vehicle Protection plans are the ONLY vehicle extended protection plans authorized, endorsed and backed by FCA US LLC to provide additional protection beyond your vehicle's warranty. If you purchased a Mopar® Vehicle Protection Plan, you will receive Plan Provisions and an Owner Identification Card in the mail within three weeks of the vehicle delivery date. If you have any questions about the service contract, call FCA US LLC's Service Contract National Customer Hotline at 1-800-521-9922.

For Canadian residents, you may have purchased additional coverage with an extended service contract. FCA Canada Inc. stands fully behind its service contracts. Be sure that the one you buy is a genuine Canada Inc. service contract. We are not responsible for other companies' contracts. If you purchased a contract other than a genuine FCA Canada Inc. service contract and you have a problem, you will have to contact the administrator of that contract for resolution. If you have any questions about the service contract, call the FCA's Service Contract National Customer Hotline at (800) 465-2001 English / (800) 387-9983 French).

Mopar Vehicle Protection Plans offer valuable protection against repair costs after your vehicle warranties have expired. Mopar Vehicle Protection plans are the ONLY vehicle extended protection plans authorized, endorsed and backed by FCA US LLC to provide additional protection beyond your vehicle's warranty.

FCA US LLC is not responsible for any service contract you may have purchased from another manufacturer. If you require service after the FCA US LLC New Vehicle Limited Warranty expires, please refer to the contract documents, and contact the person listed in those documents.

We appreciate that you have made a major investment when you purchased the vehicle. An authorized dealer has also made a major investment in facilities, tools, and training to assure that you are absolutely delighted with the ownership experience.

## WARRANTY INFORMATION

See the Warranty Information for the terms and provisions of FCA US LLC warranties applicable to this vehicle and market. Refer to [www.mopar.com/om](http://www.mopar.com/om) for further information.

See the Warranty Information for the terms and provisions of FCA Canada Inc. warranties applicable to this vehicle and market. Refer to [www.owners.mopar.ca/en](http://www.owners.mopar.ca/en) for further information.

For French, refer to [www.owners.mopar.ca/fr](http://www.owners.mopar.ca/fr) for further information.

Use this QR code to access your digital experience.



## MOPAR® PARTS

Mopar® original equipment parts & accessories and factory filled fluids are available from an authorized dealer. They are recommended for your vehicle to keep it operating at its best and maintain its original condition.

## REPORTING SAFETY DEFECTS

### IN THE 50 UNITED STATES AND WASHINGTON, D.C.

If you believe that your vehicle has a defect that could cause a crash or cause injury or death, you should immediately inform the National Highway Traffic Safety Administration (NHTSA) in addition to notifying FCA US LLC.

If NHTSA receives similar complaints, it may open an investigation, and if it finds that a safety defect exists in a group of vehicles, it may order a recall and remedy campaign. However, NHTSA cannot become involved in individual problems between you, an authorized dealer or FCA US LLC.

To contact NHTSA, you may call the Vehicle Safety Hotline toll free at 1-888-327-4236 (TTY: 1-800-424-9153); or go to <http://www.safercar.gov>; or write to: Administrator, NHTSA, 1200 New Jersey Avenue, SE., West Building, Washington, D.C. 20590. You can also obtain other information about motor vehicle safety from <http://www.safercar.gov>.

To contact NHTSA, you may call the Vehicle Safety Hotline toll free at: 1-888-327-4236

## IN CANADA

If you believe that your vehicle has a safety defect, you should contact the Customer Service Department immediately. Canadian customers who wish to report a safety defect to the Canadian government should contact Transport Canada, Motor Vehicle Defect Investigations and Recalls at 1-800-333-0510 or go to <http://www.tc.gc.ca/roadsafety/>.

## ORDERING AND ACCESSING OWNER'S INFORMATION

To order the following manuals, you may use either the website or the phone numbers listed below.

### Service Manuals

These comprehensive Service Manuals provide a complete working knowledge of the vehicle, system, and/or components and is written in straightforward language with illustrations, diagrams, and charts.

### Diagnostic Procedure Manuals

Diagnostic Procedure Manuals are filled with diagrams, charts and detailed illustrations. These manuals make it easy to find and fix problems on computer-controlled vehicle systems and features. They show exactly how to find and correct problems, using step-by-step troubleshooting and drivability procedures, proven diagnostic tests and a complete list of all tools and equipment.

To order a digital copy of your Service or Diagnostic Procedure manuals, visit:

[www.techauthority.com](http://www.techauthority.com) (US and Canada).

### Owner's Manuals

These Owner's Manuals have been prepared with the assistance of service and engineering specialists to acquaint you with specific FCA vehicles.

To access your Owner's Information online, visit [www.mopar.com/om](http://www.mopar.com/om) (US) or [www.owners.mopar.ca/en/](http://www.owners.mopar.ca/en/) (Canada).

Or visit:

[www.techauthority.com](http://www.techauthority.com) to order physical copies of Owner's Manuals (US).

Owner's Manuals, Radio Manuals and Warranty Information Books can be ordered through Archway at:

- 1-800-387-1143 (Canada)

## CHANGE OF OWNERSHIP OR ADDRESS

\*If you have purchased this vehicle used or have changed your address, please provide the following information and mail to:

### FCA US LLC

P.O. Box 21-8008

Auburn Hills, MI 48321-8004

Make sure to include the following:

- Date of Sale (mm/dd/yy)
- Vehicle Identification Number (17 Character ID located on top left of the instrument panel)
- Exact Odometer Reading
- First and Last Name
- Phone Number
- Street Address, City, State and Zip Code
- Email Address

\*Applies to US residents only.

## GENERAL INFORMATION

### RADIO

Harman International Industries, Inc. 30001 Cabot Drive - Novi, MI 48377 Digital Transmission System Model: R1 EXT NA 3B MY22, R1 EXT NA 3B MY22, R1 INT NA 3B MY22 Automotive Infotainment Unit with Bluetooth/WLAN- FC C15/15E Range (MHZ) 2412.0 - 2462.0 /5180.0 - 5240.0/5745.0 - 5825.0 This device must be installed to provide a separation distance of at least 20 cm from all persons and must not be co-located or operating in conjunction with any other antenna or transmitter, except the collocation as described in this filing and/or in accordance with FCC multi-transmitter product guidelines.

End-users and installers must be provided with installation and operating instructions for satisfying RF exposure compliance requirements. FCC ID information to be provided on the product label: 6434C-BE2857, 2AHPN-BE2857, 2AHPN-BE2862 CANADA: Harman International Industries, Inc. 30001 Cabot Drive Novi, MI 48377 Model: R1 EXT NA 3B MY22, R1 EXT NA 3B MY22, R1 INT NA 3B MY22 FCC Part 15.19 Labelling requirements.

This device complies with part 15 of the FCC Rules and Industry Canada license-exempt RSS standard(s). Operation is subject to the following two conditions:

1. This device may not cause harmful interference, and
2. This device must accept any interference received, including interference that may cause undesired operation.

Le présent appareil est conforme aux CNR d'Industrie Canada applicables aux appareils radio exempts de licence. L'exploitation est autorisée aux deux conditions suivantes:

1. L'appareil ne doit pas produire de brouillage, et
2. FCC ID information to be provided on the product label: 6434C-BE2857, 2AHPN-BE2857, 2AHPN-BE2862.

La operación de este equipo está sujeta a las siguientes dos condiciones:

1. Es posible que este equipo o dispositivo no cause interferencia perjudicial y

2. Este equipo o dispositivo debe aceptar cualquier interferencia, incluyendo la que pueda causar su operación no deseada.

### RF Exposure Requirements

To comply with FCC RF exposure compliance requirements, the device must be installed and operated to provide a separation distance of at least 20 cm from all persons.

This equipment complies with Canada radiation exposure limits set forth for an uncontrolled environment. This equipment should be installed and operated with minimum distance 20 cm between the radiator and your body.

### Déclaration d'exposition aux radiations

Cet équipement est conforme aux limites d'exposition aux rayonnements ISED établies pour un environnement non contrôlé. Cet équipement doit être installé et utilisé avec un minimum de 20 cm de distance entre la source de rayonnement et votre corps.

### NOTE:

Changes or modifications not expressly approved by the party responsible for compliance could void the user's authority to operate the equipment.

### NOTE:

Remarque: Les changements ou modifications non expressément approuvés par la partie responsable de la conformité peuvent annuler l'autorisation de l'utilisateur à utiliser l'équipement.

### ACC and FCW — USA

This device complies with Part 15 of the FCC Rules.

Operation is subject to the following two conditions:

1. This device must not cause interference, and
2. This device must accept any interference, including interference that may cause undesired operation of the device.

Changes or modifications made to this equipment not expressly approved by Robert BOSCH GmbH may void the FCC authorization to operate this equipment.

This equipment has been tested and found to comply with the limits for a Class A digital device, pursuant to Part 15 of the FCC Rules. These limits are designed to provide reasonable protection against harmful interference when the equipment is operated in a commercial environment. This equipment generates, uses, and can radiate radio frequency energy and, if not installed and used in accordance with the instruction manual, may cause harmful interference to radio communications. Operation of this equipment in a residential area is likely to cause harmful interference in which case the user will be required to correct the interference at his own expense.

**ACC and FCW – Canada**

This device complies with Industry Canada license-exempt RSS standard(s). Operation is subject to the following two conditions:

Le présent appareil est conforme aux CNR d'Industrie Canada applicables aux appareils radio exempts de licence. L'exploitation est autorisée aux deux conditions suivantes:

1. This device must not cause interference, and  
L'appareil ne doit pas produire de brouillage, et
2. This device must accept any interference, including interference that may cause undesired operation of the device.

L'utilisateur de l'appareil doit accepter tout brouillage radioélectrique subi, même si le brouillage est susceptible d'en compromettre le fonctionnement.

**RF Radiation Exposure Information – USA**

This equipment complies with FCC radiation exposure limits set forth for an uncontrolled environment. This equipment should be installed and operated with a minimum distance of 20 cm between the radiator and your body.

This transmitter must not be co-located or operating in conjunction with any other antenna or transmitter.

**RF Radiation Exposure Information – Canada**

This equipment complies with FCC and IC radiation exposure limits set forth for an uncontrolled environment. This equipment should be installed and operated with a minimum distance of 20 cm between the radiator and your body.

Cet équipement est conforme aux limites d'exposition aux rayonnements IC établies pour un environnement non contrôlé. Cet équipement doit être installé et utilisé avec un minimum de 20 cm de distance entre la source de rayonnement et votre corps.

This transmitter must not be co-located or operating in conjunction with any other antenna or transmitter.

Ce transmetteur ne doit pas être placé au même endroit ou utilisé simultanément avec un autre transmetteur ou antenne.

**BSM**

This device complies with Part 15 of the FCC Rules and with Industry Canada's RSS - 310. Operation is subject to the following two conditions:

1. This device may not cause harmful interference, and
2. This device must accept any interference received, including interference that may cause undesired operation.

Cet appareil est conforme au RSS - 310 d'Industrie Canada. Le fonctionnement est soumis à la condition que cet appareil ne provoque pas d'interférences nuisibles et accepte toute interférence, y compris les interférences susceptibles de provoquer un fonctionnement indésirable de l'appareil.

**CAUTION TO USERS**

Changes or modifications not expressly approved by the party responsible for compliance could void the users authority to operate the equipment.

# INDEX

## A

Active Driving Assist ..... 3, 87, 89, 97  
 Active Speed Limiter ..... 3, 74  
 Adaptive Cruise Control (ACC) ..... 3, 78  
 Adding Engine Coolant (Antifreeze) ..... 183  
 Adding Washing Fluid ..... 4, 180  
 Air Bag ..... 150  
   Advance Front Air Bag ..... 150  
   Air Bag Operation ..... 150  
   Air Bag Warning Light ..... 149  
   Driver Knee Air Bag ..... 151  
   Enhanced Accident Response ..... 4, 154, 177  
   Event Data Recorder (EDR) ..... 4, 177  
   Front Air Bag ..... 150  
   If Deployment Occurs ..... 153  
   Knee Impact Bolsters ..... 151  
   Maintaining Your Air Bag System ..... 154  
   Maintenance ..... 154  
   Side Air Bags ..... 151  
   Transporting Pets ..... 4, 164  
 Air Bag Light ..... 149, 165  
 Air Conditioner Maintenance ..... 4, 181  
 Air Conditioner Refrigerant ..... 4, 181  
 Air Conditioner System ..... 4, 181  
 Air Conditioning Filter ..... 47, 181  
 Air Conditioning, Operating Tips ..... 47

Air Pressure ..... 196  
   Tires ..... 197  
 Alterations/Modifications  
   Vehicle ..... 2, 7  
 Anti-Lock Brake System (ABS) ..... 4, 131  
 Anti-Lock Warning Light ..... 65, 67  
 Antifreeze (Engine Coolant) ..... 183  
   Disposal ..... 184  
 Assist, Hill Start ..... 135  
 Audio Systems (Radio) ..... 4, 113  
 Auto Down Power Windows ..... 2, 52  
 Auto Hold ..... 68  
 Automatic Dimming Mirror ..... 2, 37  
 Automatic Door Locks ..... 2, 31  
 Automatic High Beams ..... 2, 39  
 Automatic Transmission ..... 185  
   Adding Fluid ..... 185  
   Fluid And Filter Change ..... 185  
   Fluid Change ..... 185  
   Fluid Level Check ..... 4, 185  
   Fluid Type ..... 5, 185, 207  
   Special Additives ..... 185  
 Auxiliary Driving Systems ..... 4, 136

## B

B-Pillar Location ..... 194

Battery ..... 4, 63, 180  
   Charging ..... 2, 12, 14  
   Charging System Light ..... 63  
   Keyless Key Fob Replacement ..... 25  
 Belts, Seat ..... 165  
 Blind Spot Monitoring ..... 4, 136  
 Body Mechanism Lubrication ..... 4, 181  
 Brake Control System, Electronic ..... 4, 133  
 Brake Fluid ..... 5, 184, 207  
 Brake System ..... 4, 5, 184, 205  
   Fluid Check ..... 184  
   Master Cylinder ..... 184  
   Parking ..... 3, 70  
   Warning Light ..... 62, 65  
 Brightness, Interior Lights ..... 41  
 Bulb Replacement ..... 4, 190  
 Bulbs, Light ..... 166, 190

## C

Camera, Rear ..... 3, 108  
 Capacities, Fluid ..... 5, 206  
 Caps, Filler  
   Radiator (Coolant Pressure) ..... 183  
 Car Washes ..... 203  
 Cargo Compartment ..... 3, 55  
 Chains, Tire ..... 4, 201



Charging .....	2, 14
Checking Your Vehicle For Safety .....	4, 164
Checks, Safety .....	4, 164
Child Restraint .....	4, 155
Child Restraints .....	
Booster Seats .....	157
Child Seat Installation .....	163
How To Stow An unused ALR Seat Belt .....	161
Infant And Child Restraints .....	157
Lower Anchors And Tethers For Children .....	159
Older Children And Child Restraints .....	157
Seating Positions .....	158
Cleaning .....	
Wheels .....	4, 200
Climate Control .....	43
Automatic .....	43, 45
Connected Vehicles .....	4, 165
Console .....	48
Floor .....	48
Contract, Service .....	5, 210
Cooling Pressure Cap (Radiator Cap) .....	183
Cooling System .....	4, 182
Adding Coolant (Antifreeze) .....	183
Coolant Level .....	183, 184
Cooling Capacity .....	5, 206
Disposal Of Used Coolant .....	184
Drain, Flush, And Refill .....	183
Inspection .....	184
Points To Remember .....	184
Pressure Cap .....	183
Radiator Cap .....	183
Selection Of Coolant (Antifreeze) .....	5, 183, 206
Corrosion Protection .....	5, 202
Cruise Control (Speed Control) .....	3, 78
Cruise Light .....	68, 69
Cupholders .....	2, 49
Customer Assistance .....	5, 208
Cybersecurity .....	4, 113
<b>D</b>	
Daytime Running Lights .....	2, 38, 39
Dealer Service .....	4, 181
Defroster, Windshield .....	165
Dimmer Switch .....	
Headlight .....	2, 38
Dipsticks .....	
Automatic Transmission .....	185
Disposal .....	
Antifreeze (Engine Coolant) .....	184
Door Ajar .....	63
Door Ajar Light .....	63
Door Locks .....	
Automatic .....	2, 31
Doors .....	2, 28
Driver's Seat Back Tilt .....	2, 33
Driving .....	
Through Flowing, Rising, Or Shallow .....	
Standing Water .....	4, 111
Drowsy Driver Detection (DDD) .....	4, 131
Dynamic Selector .....	3, 73

**E**

Electric Brake Control System .....	4, 133
Electrical Power Outlets .....	2, 50
Electronic Stability Control (ESC) .....	133
Emergency .....	
In Case Of .....	4, 169
Emergency, In Case Of .....	
Hazard Warning Flasher .....	4, 167
Towing .....	4, 176
Engine .....	
Compartment .....	4, 180
Coolant (Antifreeze) .....	5, 183, 206
Cooling .....	4, 182
Oil .....	5, 206
Overheating .....	4, 175
Enhanced Accident Response Feature .....	
4, 154, 177	
Exterior Lighting .....	2, 38
Exterior Lights .....	2, 38, 166

**F**

Filters .....	
Air Conditioning .....	47, 181
Flash-To-Pass .....	2, 38
Flashers .....	
Turn Signals .....	2, 38, 68, 166
Floor Console .....	48
Fluid Leaks .....	166

## Fluid Level Checks

Automatic Transmission .....	185
Brake .....	184
Cooling System .....	183
Fog Lights .....	2, 38, 40, 67
Fog Lights, Rear .....	2, 40
Fold-Flat Seats .....	2, 33
Forward Collision Warning .....	4, 138
Freeing A Stuck Vehicle .....	4, 176
Front And Rear Park Assist System .....	3, 99
Fuel	
Octane Rating .....	5, 206
Fuses .....	4, 186

## G

Glass Cleaning .....	5, 204
----------------------	--------

## H

## Hazard

Driving Through Flowing, Rising, Or Shallow Standing Water .....	4, 111
Head Restraints .....	2, 35
Headlights .....	2, 38, 39
Cleaning .....	202
High Beam/Low Beam Select Switch .....	2, 38
Lights On Reminder .....	2, 38
Passing .....	2, 38, 40
Switch .....	2, 38, 39

Time Delay .....	2, 38
Heated Mirrors .....	2, 37, 38
Heated Seats .....	2, 34
High Voltage Battery .....	2, 12
Hill Start Assist .....	135
Hood Prop .....	2, 53
Hood Release .....	2, 53

## I

Ignition .....	2, 27
Switch .....	2, 27
Immobilizer (Sentry Key) .....	2, 27
Instrument Cluster .....	3, 56
Descriptions .....	3, 57, 68
Display .....	3, 57
Instrument Panel Lens Cleaning .....	204
Intelligent Speed Assist .....	3, 75
Interior Appearance Care .....	5, 203
Interior Lights .....	2, 40
Internal Equipment	
Storage .....	2, 48
iPod/USB/MP3 Control .....	2, 49

## J

Jump Starting .....	4, 173
---------------------	--------

## K

## Key Fob

Keyless Entry .....	2, 29
Remote Keyless Entry .....	2, 24
Key Fob Battery Service (Remote Keyless Entry) .....	25
Keyless Enter 'n Go™	
Enter The Trunk .....	2, 29
Lock The Vehicle's Doors .....	2, 29
Passive Entry .....	2, 29
Passive Entry Programming .....	2, 29
Remote Control .....	2, 29
Unlock From The Driver's Side .....	2, 29
Unlock From The Passenger's Side .....	2, 29
Keyless Entry .....	2, 24
Keys .....	2, 24
Sentry (Immobilizer) .....	2, 27

## L

Lane Change And Turn Signals .....	2, 38
Lane Change Assist .....	2, 38, 40
LaneSense .....	3, 106
Lap/Shoulder Belts .....	145
Latches .....	166
Hood .....	2, 53
Leaks, Fluid .....	166
Life Of Tires .....	199
Liftgate .....	2, 54

Closing .....	3, 54
Light Bulbs .....	166, 190
Lights .....	2, 39, 166
Air Bag .....	62, 149, 165
Anti Lock Brake System .....	65
Battery Charge .....	63
Brake Assist Warning .....	134
Brake Warning .....	62, 65
Bulb Replacement .....	4, 190
Cruise .....	68, 69
Daytime Running .....	2, 38
Dimmer Switch, Headlight .....	2, 38
Door Open .....	63
Drowsiness Detected .....	63, 65
Electronic Park Brake .....	65
Electronic Stability Program(ESP) Indicator .....	134
Exterior .....	166
Fog .....	2, 40, 67
Forward Collision Warning .....	67
Headlights .....	2, 38
High Beam .....	2, 39
High Beam/Low Beam Select .....	2, 38
Instrument Cluster .....	2, 38
Intensity Control .....	41
Interior .....	2, 40
Lights On Reminder .....	2, 38
Low Washer Fluid .....	66
Park .....	2, 40, 68
Passing .....	2, 38, 40
Plug Status Fault .....	64

Seat Belt Reminder .....	64
Service .....	4, 190
Service Forward Collision Warning .....	66
Tire Pressure Monitoring (TPMS) .....	4, 141
Torque Limited .....	65
Traction Control .....	134
Turn Signals .....	2, 38, 40, 68, 166
Vanity Mirror .....	2, 37
Warning Instrument Cluster Descriptions ...	68
Loading Vehicle Tires .....	194
Low Tire Pressure System .....	4, 141
Lubrication, Body .....	4, 181
Lug Nuts/Bolts .....	5, 205

## M

Maintenance Free Battery .....	4, 180
Maintenance Schedule .....	4, 178
Manual Service .....	5, 211
Mirrors .....	2, 37
Automatic Dimming .....	2, 37
Heated .....	2, 37, 38
Outside .....	2, 37
Rearview .....	2, 37
Vanity .....	2, 37
Modifications/Alterations Vehicle .....	2, 7
Monitor, Tire Pressure System .....	4, 141
MP3 Control .....	2, 49

Multi-Function Control Lever .....	2, 38, 39
------------------------------------	-----------

## O

Occupant Restraints .....	4, 143
Oil, Engine .....	5, 206
Operator Manual Owner's Manual .....	5, 211
Outside Rearview Mirrors .....	2, 37
Overheating, Engine .....	4, 175

## P

Paint Care .....	5, 202
Park Assist .....	3, 99
Park Assist System, Front And Rear .....	3, 99
Parking Brake .....	3, 70
Passing Light .....	2, 40
Pedestrian Warning System .....	4, 132
Pets .....	4, 164
Placard, Tire And Loading Information .....	194
Power Mirrors .....	2, 38
Outlet (Auxiliary Electrical Outlet) .....	2, 50
Power Steering Fluid .....	3, 74
Pregnant Women And Seat Belts .....	147
Pretensioners .....	146
Seat Belts .....	147
Profile Settings .....	116
Programmable Features .....	4, 113

## Q

Quiet Vehicle Pedestrian Module (QVPM) . 4, 132

## R

Radial Ply Tires ..... 198  
 Radiator Cap (Coolant Pressure Cap) ..... 183  
 Radio  
     Settings ..... 4, 113  
     Sound Setting ..... 125  
 Radio Remote Controls ..... 4, 129  
 Rain Sensitive Wiper System ..... 2, 43  
 Rear Camera ..... 3, 108  
 Rear Seat Reminder Alert ..... 4, 133  
 Recreational Towing ..... 4, 110  
 Refrigerant ..... 181  
 Regentive-Braking-System (RBS) ..... 4, 132  
 Release, Hood ..... 2, 53  
 Reminder, Lights On ..... 2, 38  
 Reminder, Seat Belt ..... 144  
 Remote Keyless Entry ..... 2, 24  
 Remote Sound System (Radio) Control ..... 4, 129  
 Replacement Bulbs ..... 190  
 Replacement Tires ..... 199  
 Reporting Safety Defects ..... 5, 210  
 Restraints, Child ..... 4, 155  
 Restraints, Head ..... 2, 35  
 Rotation, Tires ..... 4, 201

## S

Safety Checks Inside Vehicle ..... 4, 165  
 Safety Checks Outside Vehicle ..... 4, 166  
 Safety Defects, Reporting ..... 5, 210  
 Safety Information, Tire ..... 4, 192  
 Safety Tips ..... 4, 164  
 Schedule, Maintenance ..... 4, 178  
 Seat Belts ..... 4, 144, 165  
     Child Restraints ..... 4, 155  
     Energy Management Feature ..... 148  
     Extender ..... 147  
     Front Seat ..... 4, 144–146  
     Inspection ..... 165  
     Lap/Shoulder Belt Operation ..... 146  
     Lap/Shoulder Belt Untwisting ..... 147  
     Lap/Shoulder Belts ..... 145  
     Operating Instructions ..... 146  
     Pregnant Women ..... 147  
     Pretensioners ..... 147  
     Rear Seat ..... 145  
     Reminder ..... 144  
     Seat Belt Extender ..... 147  
     Seat Belt Pretensioner ..... 147  
     Untwisting Procedure ..... 147  
 Seat Belts Maintenance ..... 203  
 Seats ..... 2, 33  
     Adjustment ..... 2, 33  
     Heated ..... 2, 34  
     Rear Folding ..... 2, 33  
     Tilting ..... 2, 33

Selection Of Coolant (Antifreeze) ..... 5, 206  
 Sentry Key (Immobilizer) ..... 2, 27  
 Service Assistance ..... 5, 208  
 Service Contract ..... 5, 210  
 Service Manuals ..... 5, 211  
 Shoulder Belts ..... 145  
 Side Distance Warning ..... 3, 104  
 Side View Mirror Adjustment ..... 2, 37  
 Signals, Turn ..... 2, 38, 40, 68, 166  
 Single-Speed-Transmission ..... 3, 72  
 Snow Chains (Tire Chains) ..... 4, 201  
 Snow Tires ..... 200  
 SOS and Assist System ..... 4, 167  
 Speed Limiter, Active ..... 3, 74  
 Starting ..... 3, 70  
     Button ..... 2, 27  
 Starting And Operating ..... 3, 70  
 Starting Procedures ..... 3, 70  
 Steering  
     Tilt Column ..... 2, 32  
     Wheel, Heated ..... 2, 32  
     Wheel, Tilt ..... 2, 32  
 Steering Wheel Audio Controls ..... 4, 129  
 Steering Wheel Mounted Sound System ... 4, 129  
 Storage ..... 2, 48  
 Storage, Vehicle ..... 5, 47, 202  
 Storing Your Vehicle ..... 5, 202  
 Supplemental Restraint System – Air Bag  
 ..... 4, 149, 150  
 Symbol Glossary ..... 2, 7

## T

Telescoping Steering Column .....	2, 32
Temperature Control, Automatic (ATC) .....	45
Tilt Steering Column .....	2, 32
Time Delay .....	38
Headlight .....	2, 38
Tire And Loading Information Placard .....	194
Tire Markings .....	192
Tire Safety Information .....	4, 192
Tire Service Kit .....	4, 169
Tires .....	4, 5, 166, 196, 201
Aging (Life Of Tires) .....	199
Air Pressure .....	196
Chains .....	4, 201
Flat Changing .....	4, 169
General Information .....	4, 196
High Speed .....	197
Inflation Pressure .....	197
Life Of Tires .....	199
Load Capacity .....	194, 195
Pressure Monitoring System (TPMS) .....	4, 66, 141
Quality Grading .....	5, 201
Radial .....	198
Replacement .....	199
Rotation .....	4, 201
Safety .....	4, 192, 196
Snow Tires .....	200
Spinning .....	198
Tread Wear Indicators .....	198
Wheel Nut Torque .....	5, 205
To Open Hood .....	2, 53
Towing .....	4, 110
Disabled Vehicle .....	4, 176
Recreational .....	4, 110
Towing Behind A Motorhome .....	4, 110
Traction .....	4, 111
Traffic Sign Assist System .....	3, 76
Traffic Sign Recognition System .....	67
Trailer Towing .....	4, 110
Transmission .....	4, 185
Automatic .....	4, 185
Fluid .....	5, 207
Maintenance .....	4, 185
Transporting Passengers .....	4, 164
Transporting Pets .....	4, 164
Tread Wear Indicators .....	198
Turn Signals .....	2, 38, 40, 68

## U

Uconnect Settings .....	4, 113
Uniform Tire Quality Grades .....	5, 201
Untwisting Procedure, Seat Belt .....	147
USB .....	2, 49

## V

Vanity Mirrors .....	2, 37
Vehicle Identification Number (VIN) .....	5, 205

Vehicle Loading .....	3, 109, 195
Vehicle Modifications/Alterations .....	2, 7
Vehicle Settings .....	4, 113
Vehicle Storage .....	5, 47, 202

## W

Warning Lights (Instrument Cluster Descriptions) .....	65
Warning Lights And Messages .....	3, 62
Warranty Information .....	5, 210
Washer .....	203
Adding Fluid .....	4, 180
Washers, Windshield .....	2, 42
Washing Vehicle .....	203
Water .....	203
Driving Through .....	4, 111
Wheel And Wheel Tire Care .....	4, 200
Wheel And Wheel Tire Trim .....	4, 200
Window Fogging .....	47
Windows .....	2, 52
Reset Auto-Up .....	2, 53
Windshield Defroster .....	165
Windshield Washers .....	2, 42
Windshield Wiper Blades .....	4, 182
Windshield Wipers .....	2, 42
Wipers Blade Replacement .....	4, 182
Wipers, Rain Sensitive .....	2, 43



The driver's primary responsibility is the safe operation of the vehicle. Driving while distracted can result in loss of vehicle control, resulting in an accident and personal injury. FCA US LLC strongly recommends that the driver use extreme caution when using any device or feature that may take their attention off the road. Use of any electrical devices, such as cellular telephones, computers, portable radios, vehicle navigation or other devices, by the driver while the vehicle is moving is dangerous and could lead to a serious accident. Texting while driving is also dangerous and should never be done while the vehicle is moving. If you find yourself unable to devote your full attention to vehicle operation, pull off the road to a safe location and stop your vehicle. Some states or provinces prohibit the use of cellular telephones or texting while driving. It is always the driver's responsibility to comply with all local laws.

This Owner's Manual has been prepared to help you get acquainted with your new FIAT® brand vehicle and to provide a convenient reference source for common questions.

Not all features shown in this manual may apply to your vehicle. For additional information, visit [mopar.com/om](http://mopar.com/om) (U.S.), [owners.mopar.ca](http://owners.mopar.ca) (Canada) or your local FIAT® brand dealer.

**U.S. Residents:** If you are the first registered retail owner of your vehicle, you may obtain a complimentary printed copy of the Warranty Booklet by calling **1-888-242-6342** or by contacting your dealer. Replacement kits can be purchased by visiting [www.techauthority.com](http://www.techauthority.com).

**Canadian Residents:** If you are the first registered retail owner of your vehicle, you may obtain a complimentary printed copy of the Warranty Booklet or purchase a replacement kit by calling **1-800-387-1143** or by contacting your dealer.



## DRIVING AND ALCOHOL

Drunk driving is one of the most frequent causes of accidents. Your driving ability can be seriously impaired with blood alcohol levels far below the legal minimum. If you are drinking, don't drive. Ride with a designated non-drinking driver, call a cab, a rideshare, a friend or use public transportation.

## WARNING

Driving after drinking can lead to an accident. Your perceptions are less sharp, your reflexes are slower and your judgment is impaired when you have been drinking. Never drink and then drive.



SCAN TO DOWNLOAD  
COMPLETE OWNER'S  
MANUAL, RADIO AND  
WARRANTY MANUALS

U.S.



[mopar.com/om](https://mopar.com/om)

Canada



[owners.mopar.ca](https://owners.mopar.ca)

**FIAT**

©2024 FCA US LLC. All Rights Reserved. Tous droits réservés. FIAT is a registered trademark of FCA Group Marketing S.p.A., used with permission. FIAT est une marque déposée de FCA Group Marketing S.p.A., utilisée avec autorisation. App Store is a registered trademark of Apple Inc. Google Play Store is a registered trademark of Google.

First Edition  
24\_FG\_B\_OM\_EN\_USC