



2022 **ROGUE**
OWNER'S MANUAL
and MAINTENANCE INFORMATION

For your safety, read carefully and keep in this vehicle.

CALIFORNIA PROPOSITION 65 WARNING



WARNING

Operating, servicing and maintaining a passenger vehicle or off-highway motor vehicle can expose you to chemicals including engine exhaust, carbon monoxide, phthalates, and lead, which are known to the State of California to cause cancer and birth defects or other reproductive harm. To minimize exposure, avoid breathing exhaust, do not idle the engine except as necessary, service your vehicle in a well-ventilated area and wear gloves or wash your hands frequently when servicing your vehicle. For more information go to www.P65Warnings.ca.gov/passenger-vehicle.

Foreword

This manual was prepared to help you understand the operation and maintenance of your vehicle so that you may enjoy many miles of driving pleasure. Please read through this manual before operating your vehicle.

A separate Warranty Information Booklet explains details about the warranties covering your vehicle. Additionally, a separate Customer Care/Lemon Law Booklet (U.S. only) will explain how to resolve any concerns you may have with your vehicle, as well as clarify your rights under your state's lemon law.

In addition to factory installed options, your vehicle may also be equipped with additional accessories installed by NISSAN or by your NISSAN dealer prior to delivery. It is important that you familiarize yourself with all disclosures, warnings, cautions and instructions concerning proper use of such accessories prior to operating the vehicle and/or accessory. It is recommended you see a NISSAN dealer for details concerning the particular accessories with which your vehicle is equipped.

Your NISSAN dealer knows your vehicle best. When you require any service or have any questions, we will be glad to assist you with the extensive resources available to us.

READ FIRST — THEN DRIVE SAFELY

Before driving your vehicle, read your Owner's Manual carefully. This will ensure familiarity with controls and maintenance requirements, assisting you in the safe operation of your vehicle.



WARNING

IMPORTANT SAFETY INFORMATION REMINDERS!

Follow these important driving rules to help ensure a safe and comfortable trip for you and your passengers!

- **NEVER** drive under the influence of alcohol or drugs.
- **ALWAYS** observe posted speed limits and never drive too fast for conditions.
- **ALWAYS** give your full attention to driving and avoid using vehicle features or taking other actions that could distract you.
- **ALWAYS** use your seat belts and appropriate child restraint systems. Pre-teen children should be seated in the rear seat.
- **ALWAYS** provide information about the proper use of vehicle

safety features to all occupants of the vehicle.

- **ALWAYS** review this Owner's Manual for important safety information.

On-pavement and off-road driving

This vehicle will handle and maneuver differently from an ordinary passenger car because it has a higher center of gravity. As with other vehicles with features of this type, failure to operate this vehicle correctly may result in loss of control or an accident. Be sure to read "Avoiding collision and rollover" and "Driving safety precautions" in the "5. Starting and driving" section of this manual.

MODIFICATION OF YOUR VEHICLE

This vehicle should not be modified. Modification could affect its performance, safety or durability, and may even violate governmental regulations. In addition, damage or performance problems resulting from modification may not be covered under NISSAN warranties.



WARNING

Installing an aftermarket On-Board Diagnostic (OBD) plug-in device that uses the port during normal driving, for example remote insurance company monitoring, remote vehicle diagnostics, telematics or engine reprogramming, may cause interference or damage to vehicle systems. We do not recommend or endorse the use of any aftermarket OBD plug-in devices, unless specifically approved by NISSAN. The vehicle warranty may not cover damage caused by any aftermarket plug-in device.

WHEN READING THE MANUAL

This manual includes information for all features and equipment available on this model. Features and equipment in your vehicle may vary depending on model, trim level, options selected, order, date of production, region or availability. Therefore, you may find information about features or equipment that are not included or installed on your vehicle.

All information, specifications and illustrations in this manual are those in effect at the time of printing. NISSAN reserves the right to change specifications, performance, design or component suppliers without notice and without obligation. From time to time, NISSAN may update or revise this manual to provide Owners with the most accurate information currently available. Please carefully read and retain with this manual all revision updates sent to you by NISSAN to ensure you have access to accurate and up-to-date information regarding your vehicle. Current versions of vehicle Owner's Manuals and any updates can also be found in the Owner section of the NISSAN website at <https://owners.nissanusa.com/nowners/navigation/manualsGuide>. If you have questions concerning any information in your Owner's Manual, contact

NISSAN Consumer Affairs. See the NISSAN CUSTOMER CARE PROGRAM page in this Owner's Manual for contact information.

IMPORTANT INFORMATION ABOUT THIS MANUAL

You will see various symbols in this manual. They are used in the following ways:



WARNING

This is used to indicate the presence of a hazard that could cause death or serious personal injury. To avoid or reduce the risk, the procedures must be followed precisely.



CAUTION

This is used to indicate the presence of a hazard that could cause minor or moderate personal injury or damage to your vehicle. To avoid or reduce the risk, the procedures must be followed carefully.

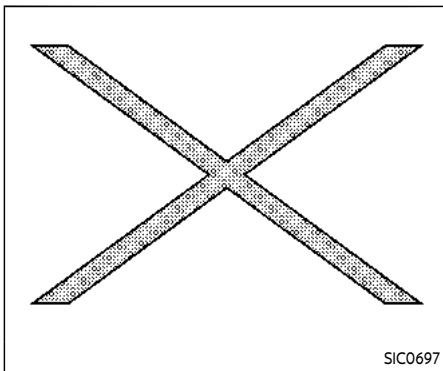

SIC0697

If you see the symbol above, it means “Do not do this” or “Do not let this happen”.

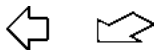

If you see a symbol similar to those above in an illustration, it means the arrow points to the front of the vehicle.



Arrows in an illustration that are similar to those above indicate movement or action.



Arrows in an illustration that are similar to

those above call attention to an item in the illustration.

CALIFORNIA PERCHLORATE ADVISORY

Some vehicle parts, such as lithium batteries, may contain perchlorate material. The following advisory is provided: “Perchlorate Material - special handling may apply, see www.dtsc.ca.gov/hazardouswaste/perchlorate.”

© 2021 NISSAN MOTOR CO., LTD.

All rights reserved. No part of this Owner's Manual may be reproduced or stored in a retrieval system, or transmitted in any form, or by any means, electronic, mechanical, photocopying, recording or otherwise, without the prior written permission of Nissan Motor Co., Ltd.

NISSAN CUSTOMER CARE PROGRAM

NISSAN CARES ...

Both NISSAN and your NISSAN dealer are dedicated to serving all your automotive needs. Your satisfaction with your vehicle and your NISSAN dealer are our primary concerns. Your NISSAN dealer is always available to assist you with all your automobile sales and service needs.

However, if there is something that your NISSAN dealer cannot assist you with or you would like to provide NISSAN directly with comments or questions, please contact the NISSAN Consumer Affairs Department using our toll-free number:

For U.S. customers

1-800-NISSAN-1

(1-800-647-7261)

For Canadian customers

1-800-387-0122

The Consumer Affairs Department will ask for the following information:

- Your name, address, and telephone number
- Vehicle identification number (attached to the top of the instrument panel on the driver's side)
- Date of purchase
- Current odometer reading
- Your NISSAN dealer's name
- Your comments or questions

OR

You can write to NISSAN with the information at:

For U.S. customers

Nissan North America, Inc.

Consumer Affairs Department

P.O. Box 685003

Franklin, TN 37068-5003

or via e-mail at:

nnaconsumeraffairs@nissan-usa.com

For Canadian customers

Nissan Canada Inc.

5290 Orbitor Drive

Mississauga, Ontario L4W 4Z5

or via e-mail at:

information.centre@nissancanada.com

If you prefer, visit us at:

www.nissanusa.com (for U.S. customers)

or

www.nissan.ca (for Canadian customers)

We appreciate your interest in NISSAN and thank you for buying a quality NISSAN vehicle.

Table of Contents

Illustrated table of contents	0
Safety – Seats, seat belts and supplemental restraint system	1
Instruments and controls	2
Pre-driving checks and adjustments	3
Monitor, heater, air conditioner, audio and phone systems	4
Starting and driving	5
In case of emergency	6
Appearance and care	7
Do-it-yourself	8
Maintenance and schedules	9
Technical and consumer information	10
Index	11

0 Illustrated table of contents

Seats, seat belts and Supplemental Restraint System (SRS)	0-2	Meters and gauges	0-8
Exterior front	0-3	Models with analog meter and color display	0-8
Exterior rear	0-4	Models with full-screen display	0-9
Passenger compartment	0-5	Engine compartment	0-10
Cockpit	0-6	PR25DD engine model	0-10
Instrument panel	0-7	KR15DDT engine model	0-11
		Warning and indicator lights	0-12

SEATS, SEAT BELTS AND SUPPLEMENTAL RESTRAINT SYSTEM (SRS)

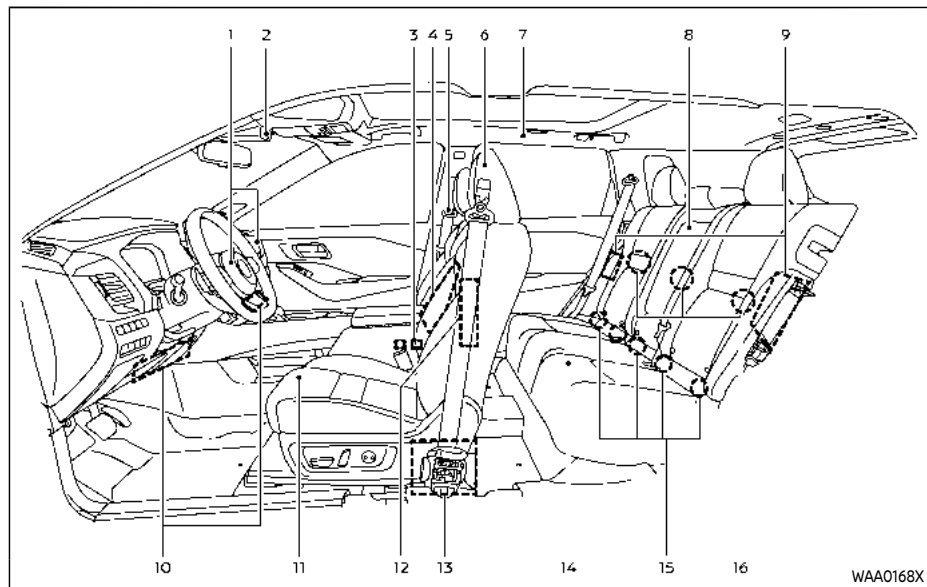

- | | |
|--------------------------------------------------------------------------|---------------------------------------------------------------------------------|
| 1. Supplemental front-impact air bags (P.1-47) | 5. Seat belts (P.1-15) |
| 2. Front passenger air bag status light (P.1-55) | 6. Head restraints/headrests (P.1-11) |
| 3. Occupant classification sensors (weight sensors) (P.1-47) | 7. Roof-mounted curtain side-impact and rollover supplemental air bags (P.1-47) |
| 4. Front central seat-mounted side-impact supplemental air bag* (P.1-47) | 8. Rear armrest (P.1-10) |
| | 9. Rear outboard seat-mounted side-impact supplemental air bags (P.1-47) |

10. Driver and front passenger supplemental knee air bags (P.1-47)
 11. Front seats (P.1-5)
 12. Front seat-mounted side-impact supplemental air bags* (P.1-47)
 13. Seat belt pretensioners (P.1-66)
 14. Rear seats (P.1-8)
 - Child restraints (P.1-25)
 15. LATCH (Lower Anchors and Tethers for Children) system (for rear seats) (P.1-27)
 16. Child restraint anchor points (for top tether strap) (P.1-43)
- *: if so equipped

EXTERIOR FRONT

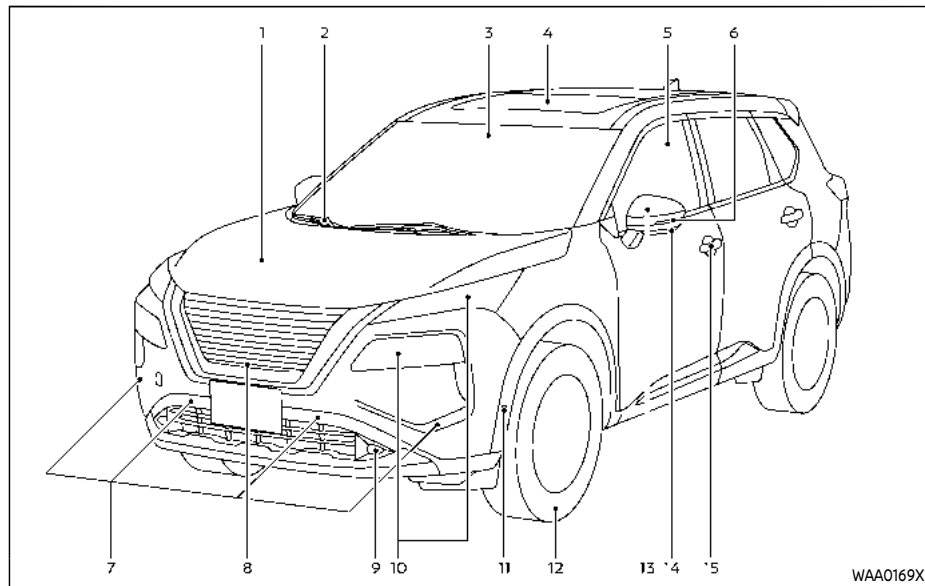

- | | |
|-------------------------------------------------------------------------------------------------|-------------------------------------------------------------------|
| 1. Hood (P.3-22) | 5. Power windows (P.2-83) |
| 2. Windshield wiper and washer
— Switch operation (P.2-55)
— Window washer fluid (P.8-13) | 6. Side turn signal light* (P.2-64) |
| 3. Front camera* (P.2-61, P.5-44, P.5-47,
P.5-52, P.5-66, P.5-85, P.5-122) | 7. Sonar sensors (center and corner)*
— Sonar system (P.5-162) |
| 4. Moonroof* (P.2-86) | 8. Front view camera* (P.4-10) |
| | 9. Fog lights* (P.2-65) |
| | 10. Headlights and turn signal lights (P.2-58) |

- | | |
|----------------------------------------------------------------------------------------------------------------------------------------------------------|---------------------------------------------------------------------------------------------------------------------------------------|
| 11. Sonar sensors (side)*
— Sonar system (P.5-162) | 12. Tires
— Wheels and tires (P.8-30, P.10-10)
— Spare tire (P.6-3)
— Tire Pressure Monitoring System (TPMS) (P.2-18, P.5-6) |
| 13. Outside mirrors (P.3-35) | 14. Side view camera* (P.4-10) |
| 15. Doors
— Keys (P.3-3)
— Door locks (P.3-5)
— Intelligent Key system (P.3-7)
— Security system (P.2-53)
— Remote engine start* (P.3-19) | *: if so equipped |

EXTERIOR REAR

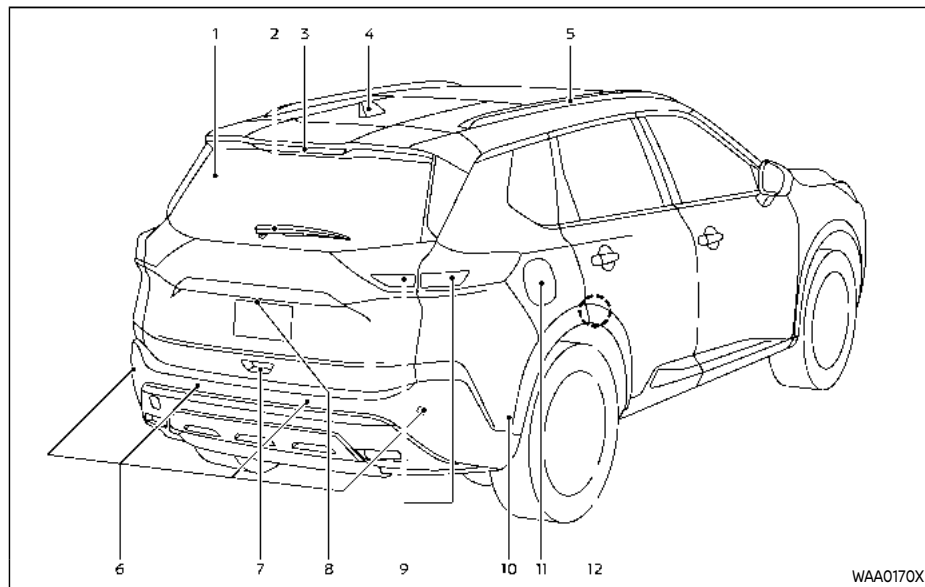

1. Rear window defroster (P.2-57)
2. Rear window wiper and washer
 - Switch operation (P.2-56)
 - Window washer fluid (P.8-13)
3. High-mounted stop light (P.8-27)
4. Antenna (P.4-39)
5. Roof rack* (P.2-82)
6. Sonar sensors (center and corner)
 - Sonar system* (P.5-162)
 - Rear Sonar System (RSS)* (P.5-168)
 - Rear Automatic Braking (RAB) (P.5-143)
7. Liftgate (P.3-23)
 - Intelligent Key system* (P.3-7)
8. Rear view camera* (P.4-3, P.4-10)

9. Rear combination light (P.8-27)
 10. Sonar sensors (side)*
 - Rear Automatic Braking (RAB) (P.5-143)
 - Sonar system (P.5-162)
 11. Fuel-filler door (P.3-29)
 - Fuel information (P.10-5)
 12. Child safety rear door locks (P.3-7)
- *: if so equipped

PASSENGER COMPARTMENT

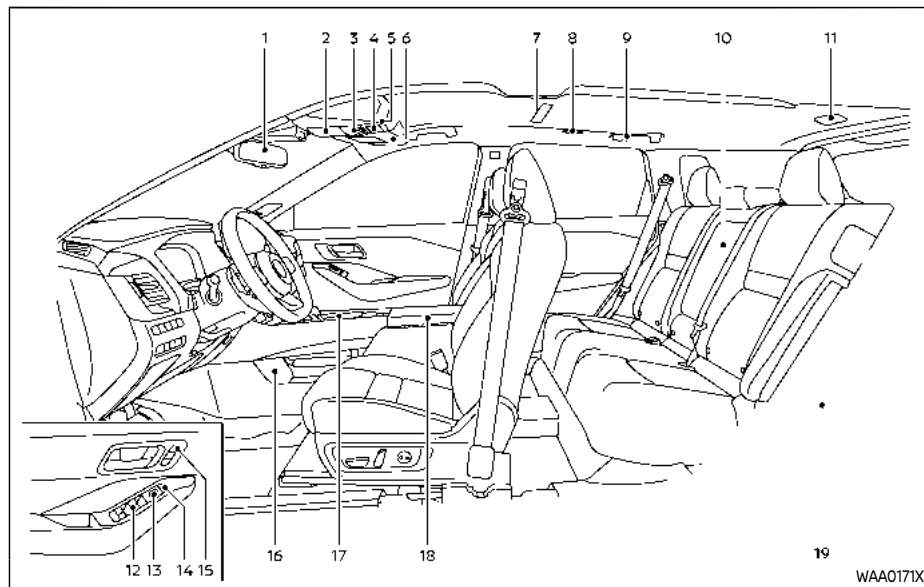

- | | |
|------------------------------------------|-----------------------------------|
| 1. Inside mirror (P.3-33) | 7. Room light* (P.2-89) |
| 2. Sunglasses holder (P.2-79) | 8. Rear personal lights* (P.2-90) |
| 3. Map lights (P.2-89) | 9. Coat hooks* (P.2-80) |
| — Microphone** | 10. Rear cup holders (P.2-74) |
| 4. Moonroof switch* (P.2-86) | 11. Cargo light (P.2-90) |
| 5. Emergency Call (SOS) button* (P.2-73) | 12. Power window switch (P.2-83) |
| 6. Sun visors (P.3-32) | |

- | |
|---------------------------------------------------------------------------|
| 13. Outside mirror control switch (driver's side) (P.3-35) |
| 14. Power door lock switches (P.3-6) |
| 15. Memory seat switches (driver's side)* (P.3-37) |
| 16. Lower console tray (P.2-79) |
| 17. Front cup holders (P.2-74) |
| 18. Console box (P.2-79) |
| — Power outlet (P.2-69) |
| — USB (Universal Serial Bus) charging connector* (P.2-70) |
| — Heated rear seat switches* (P.2-66) |
| — Rear temperature control* (P.4-37) |
| 19. Cargo area |
| — Power outlet* (P.2-69) |
| — Adjustable luggage floor* (P.2-76) |
| — Single luggage board* (P.2-76) |
| — Luggage hooks (P.2-81) |
| — Cargo cover* (P.2-81) |
| — Spare tire (P.6-5) |
| *: if so equipped |
| **: Refer to the separate NissanConnect® Owner's Manual (if so equipped). |

COCKPIT

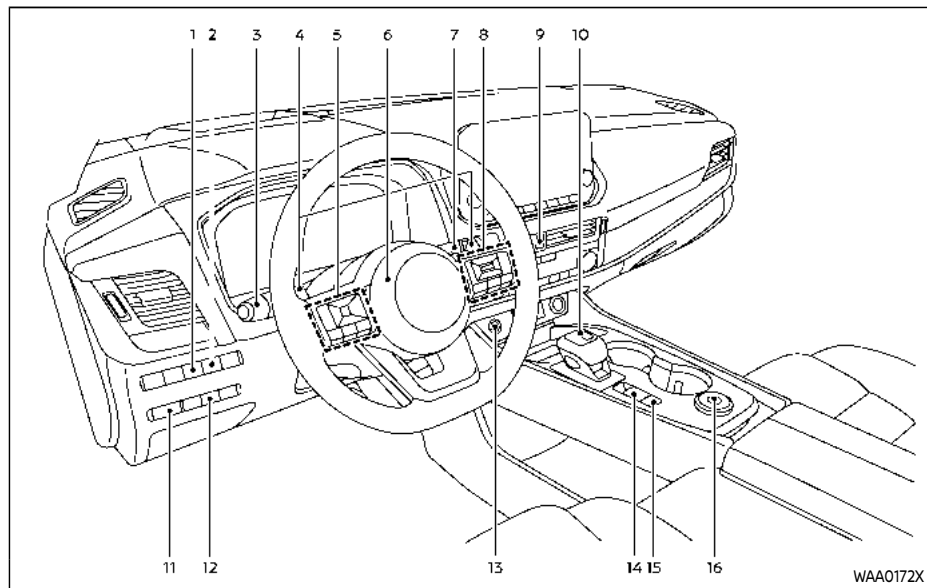

1. Steering Assist switch* (models with ProPILOT Assist) (P.2-67, P.5-85)
2. Head Up Display (HUD) switch* (P.2-50)
3. Headlight and turn signal switch (P.2-58)/ Fog light switch* (P.2-65)
4. Paddle shifters (P.5-23)
5. Steering-wheel-mounted controls (left side)

6. Steering wheel (P.3-31)
 - Horn (P.2-65)
7. Wiper and washer switch (P.2-55)
8. Steering-wheel-mounted controls (right side)
 - Audio control**
 - Vehicle information display control (P.2-23)

side)

- Cruise control switches* (P.5-83)
- ProPILOT Assist switch* (P.5-85, P.5-52, P.5-66)
- Bluetooth® Hands-Free Phone System switches**
- Voice Recognition system switch**
- Siri® Eyes Free**

9. Hazard indicator flasher switch (P.6-2)
10. Shift lever
 - Continuously Variable Transmission (CVT) (P.5-19)
11. Instrument brightness control (P.2-11)
12. Power liftgate switch* (P.3-23)
13. Push-button ignition switch (P.5-14)
14. Parking brake switch (P.5-25)
15. Automatic brake hold switch (P.5-28)
16. Drive Mode Selector*** (P.5-31)

*: if so equipped

** : See the separate NissanConnect® Owner's Manual (if so equipped).

***: The Drive Mode Selector illustrated is for the AWD model. On the 2WD model, the shape and location differ.

INSTRUMENT PANEL

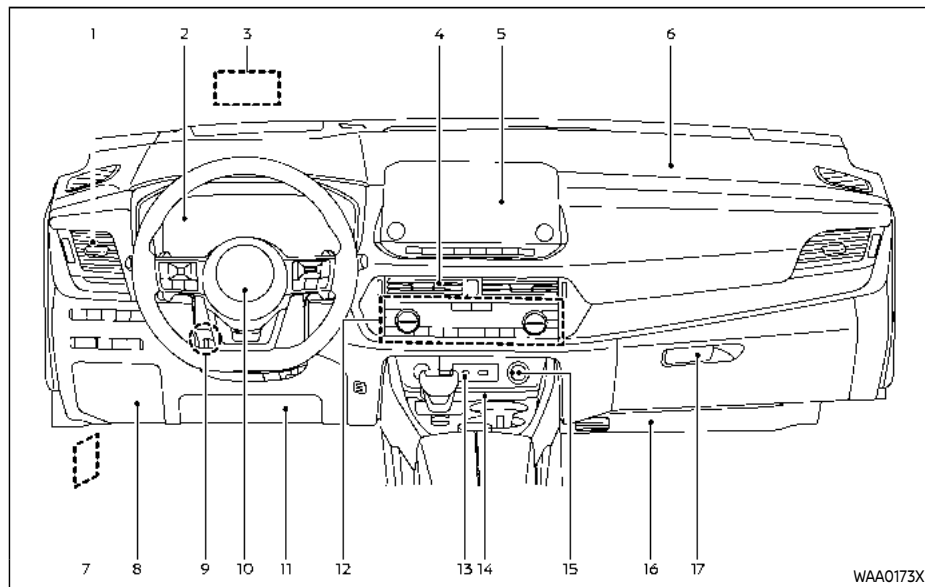

- | | |
|---------------------------------------------|--------------------------------------------------|
| 1. Side ventilator (P.4-26) | (P.4-10) |
| 2. Meters and gauges (P.2-5)/Clock (P.2-49) | – Bluetooth® Hands-Free Phone System** |
| 3. Head Up Display (HUD)* (P.2-50) | |
| 4. Center ventilator (P.4-26) | 6. Front passenger supplemental air bag (P.1-47) |
| 5. Audio system** or navigation system** | 7. Hood release handle (P.3-22) |
| – RearView Monitor* (P.4-3) | 8. Fuse box cover (P.8-23) |
| – Intelligent Around View® Monitor* | |

- | |
|-----------------------------------------------------------------------|
| 9. Tilt and telescopic steering lock lever (P.3-31) |
| 10. Driver supplemental front-impact air bag (P.1-47) |
| 11. Driver supplemental knee air bag (P.1-47) |
| 12. Heater and air conditioner control (P.4-27) |
| – Defroster switch (P.2-57) |
| – Heated seat switches* (P.2-66) |
| – Heated steering wheel switch* (P.2-66) |
| 13. USB (Universal Serial Bus) connection ports** |
| 14. Wireless charger* (P.2-70) |
| 15. Power outlet (P.2-69) |
| 16. Front passenger supplemental knee air bag (P.1-47) |
| 17. Glove box (P.2-78) |
| *: if so equipped |
| ** : See the separate NissanConnect® Owner's Manual (if so equipped). |

METERS AND GAUGES

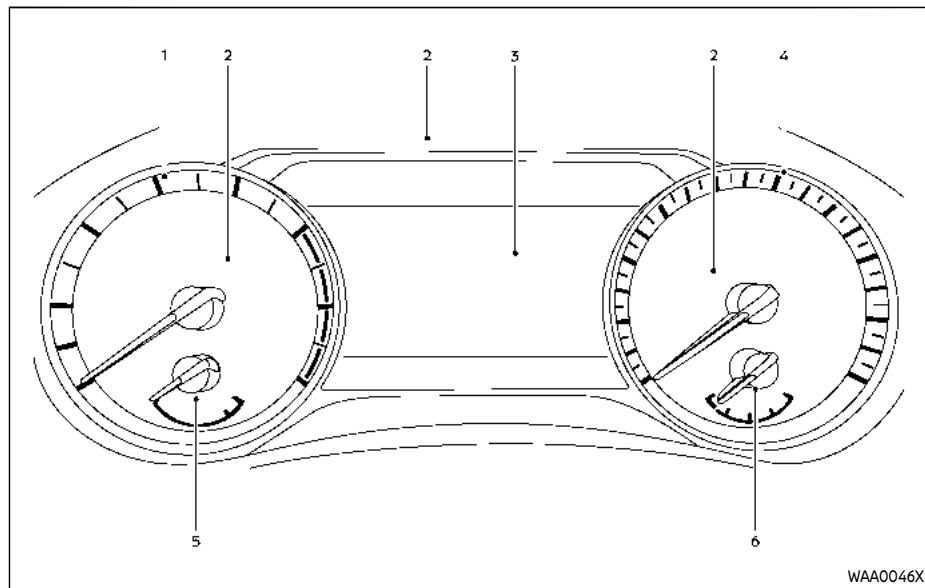

MODELS WITH ANALOG METER AND COLOR DISPLAY

1. Tachometer (P.2-9)
2. Warning and indicator lights (P.2-13)
3. Vehicle information display (P.2-22)
 - Odometer (P.2-8)
4. Speedometer (P.2-8)
5. Engine coolant temperature gauge (P.2-9)
6. Fuel gauge (P.2-10)

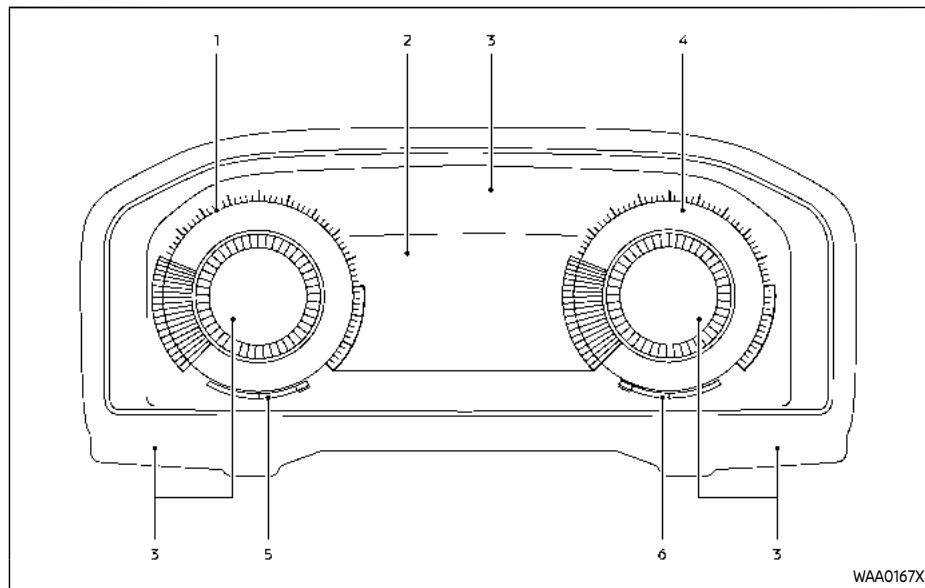

MODELS WITH FULL-SCREEN DISPLAY

1. Tachometer (P.2-9)
2. Vehicle information display (P.2-22)
— Odometer (P.2-8)
3. Warning and indicator lights (P.2-13)
4. Speedometer (P.2-8)

5. Engine coolant temperature gauge (P.2-9)
6. Fuel gauge (P.2-10)

The view of the meter screen can be changed. (See "Changing the meter screen view (models with full-screen display)" (P.2-7).)

ENGINE COMPARTMENT

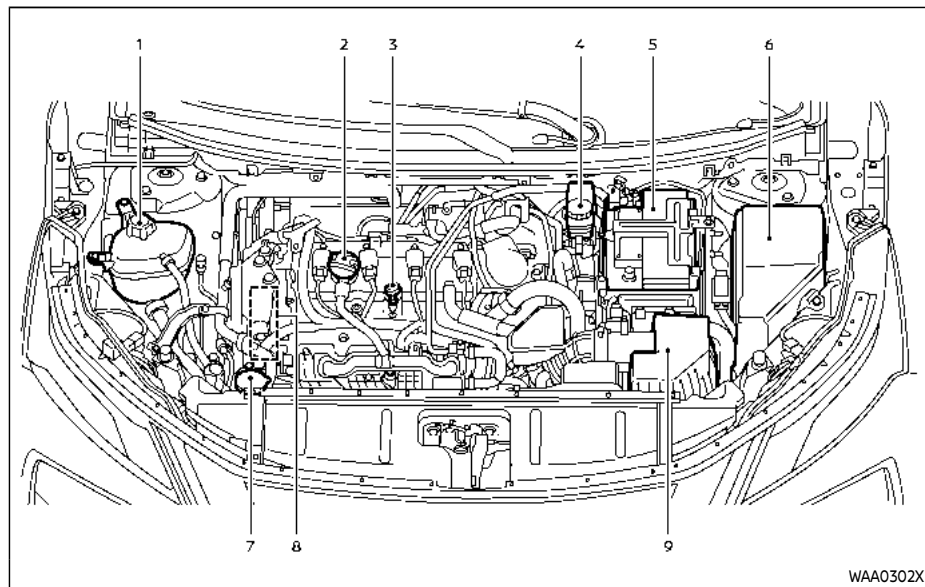

WAA0302X

PR25DD ENGINE MODEL



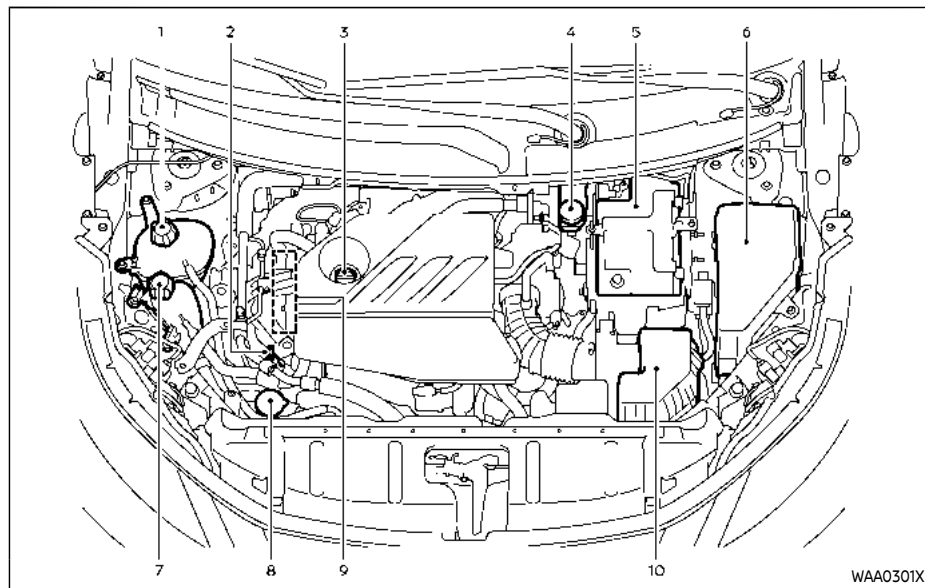







- | | |
|-------------------------------------|-------------------------------------------|
| 1. Engine coolant reservoir (P.8-6) | 7. Window washer fluid reservoir (P.8-13) |
| 2. Engine oil filler cap (P.8-8) | 8. Drive belt (P.8-16) |
| 3. Engine oil dipstick (P.8-8) | 9. Air cleaner (P.8-18) |
| 4. Brake fluid reservoir (P.8-12) | |
| 5. Battery (P.8-14) | |
| 6. Fuse/fusible link box (P.8-21) | |





















KR15DDT ENGINE MODEL

- | | |
|-------------------------------------|-------------------------------------------|
| 1. Engine coolant reservoir (P.8-6) | 7. Intercooler coolant reservoir (P.8-6) |
| 2. Engine oil dipstick (P.8-8) | 8. Window washer fluid reservoir (P.8-13) |
| 3. Engine oil filler cap (P.8-8) | 9. Drive belt (P.8-16) |
| 4. Brake fluid reservoir (P.8-12) | 10. Air cleaner (P.8-18) |
| 5. Battery (P.8-14) | |
| 6. Fuse/fusible link box (P.8-21) | |

WARNING AND INDICATOR LIGHTS

Red light	Name	Page
	Brake warning light	2-14
		
	Charge warning light	2-15
	Electric shift control system warning light	2-15
	Electronic parking brake warning light	2-15
		
	Engine oil pressure warning light	2-15
	Hands OFF warning light (if so equipped)	2-16
	Master warning light	2-16
	Seat belt warning light	2-16
	Supplemental air bag warning light	2-16

Yellow light	Name	Page
	Anti-lock Braking System (ABS) warning light	2-17
		
	Automatic Emergency Braking (AEB) system OFF warning light	2-17
	Electric power steering warning light	2-17
	Electronic parking brake system warning light	2-18
	Front passenger air bag status light	2-18
	Low tire pressure warning light	2-18
	Malfunction Indicator Light (MIL)	2-19
	Master warning light	2-20
	Rear Automatic Braking (RAB) system OFF warning light	2-20
	Slip indicator light	2-20
	Vehicle Dynamic Control (VDC) off indicator light	2-21

Other light	Name	Page
	Automatic brake hold indicator light (white)	2-21
	Automatic brake hold indicator light (green)	2-21
	Exterior light indicator	2-21
	Front fog light indicator light (if so equipped)	2-21
	High beam assist indicator light	2-21
	High beam indicator light	2-21
	Turn signal/hazard indicator lights	2-21

1 Safety — Seats, seat belts and supplemental restraint system

Seats	1-3	Child restraints	1-25
Front seats	1-5	Precautions on child restraints	1-25
Rear seats	1-8	Lower Anchors and Tethers for Children (LATCH) system	1-27
Armrest	1-10	Rear-facing child restraint installation using LATCH	1-32
Head restraints/headrests	1-11	Rear-facing child restraint installation using the seat belts	1-34
Adjustable head restraint/headrest components	1-12	Forward-facing child restraint installation using LATCH	1-36
Non-adjustable head restraint/headrest components	1-12	Forward-facing child restraint installation using the seat belts	1-39
Remove	1-12	Booster seats	1-44
Install	1-13	Supplemental Restraint System (SRS)	1-47
Adjust	1-13	Precautions on SRS	1-47
Seat belts	1-15	NISSAN Advanced Air Bag System (front seats)	1-53
Precautions on seat belt usage	1-15	Driver and front passenger supplemental knee air bag	1-62
Seat belt warning light and chime	1-17	Front, front central, rear outboard seat-mounted side-impact supplemental air bag and roof-mounted curtain side-impact and rollover supplemental air bag systems	1-64
Pregnant women	1-18	Seat belts with pretensioners (front and rear outboard seats)	1-66
Injured persons	1-18		
Three-point type seat belt with retractor	1-18		
Seat belt extenders	1-21		
Seat belt maintenance	1-22		
Child safety	1-22		
Infants	1-23		
Small children	1-23		
Larger children	1-23		

Supplemental air bag warning labels 1-67
Supplemental air bag warning light 1-67

Repair and replacement procedure 1-68

SEATS

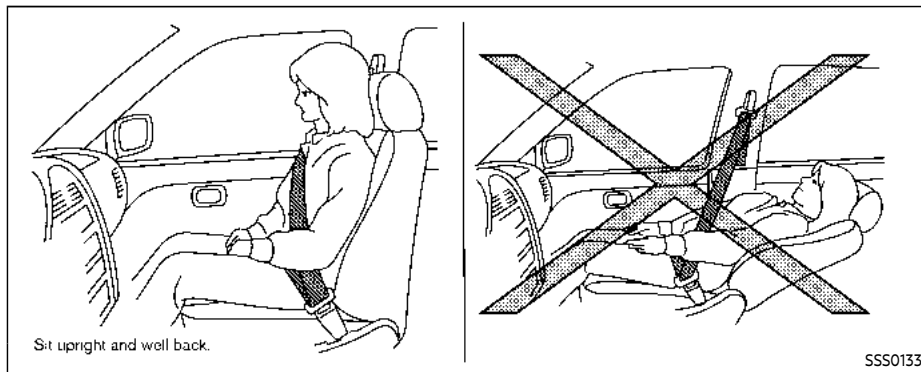

WARNING

- Do not ride in a moving vehicle when the seatback is reclined. This can be dangerous. The shoulder belt will not be against your body. In an accident, you could be thrown into it and receive neck or other serious injuries. You could also slide under the lap belt and receive serious internal injuries.
- For the most effective protection when the vehicle is in motion, the seat should be upright. Always sit

well back and upright in the seat with both feet on the floor and adjust the seat properly. See "Precautions on seat belt usage" (P.1-15).

- After adjustment, gently rock in the seat to make sure it is securely locked.
- Do not leave children unattended inside the vehicle. They could unknowingly activate switches or controls. Unattended children could become involved in serious accidents.

- To help avoid risk of injury or death through unintended operation of the vehicle and/or its systems, do not leave children, people who require the assistance of others or pets unattended in your vehicle. Additionally, the temperature inside a closed vehicle on a warm day can quickly become high enough to cause a significant risk of injury or death to people and pets.
- Do not adjust the driver's seat while driving so full attention may be given to vehicle operation. The seat may move suddenly and could cause loss of control of the vehicle.
- The seatback should not be reclined any more than needed for comfort. Seat belts are most effective when the passenger sits well back and straight up in the seat. If the seatback is reclined, the risk of sliding under the lap belt and being injured is increased.



CAUTION

When adjusting the seat positions, be sure not to contact any moving parts to avoid possible injuries and/or damage.

FRONT SEATS

Your vehicle seats can be adjusted in manual or power operation. For additional information about adjusting the seats, refer to the steps outlined in this section.

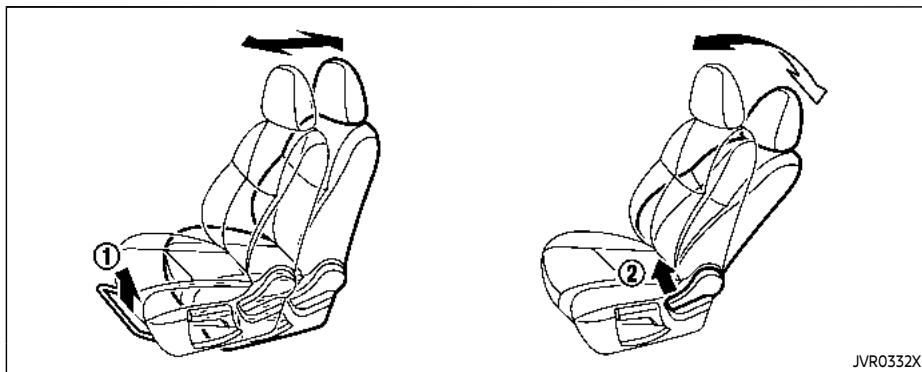

Front manual seat adjustment

Forward and backward:

1. Pull up the adjusting lever ①.
2. Slide the seat to the desired position.
3. Release the adjusting lever to lock the seat in position.

Reclining:

1. Pull up the adjusting lever ②.
2. Tilt the seatback to the desired position.
3. Release the adjusting lever to lock the seatback in position.

The reclining feature allows the adjustment of the seatback for occupants of different sizes to help obtain the proper seat belt fit. (See "Seat belts" (P.1-15).)

The seatback may be reclined to allow occupants to rest when the vehicle is parked.

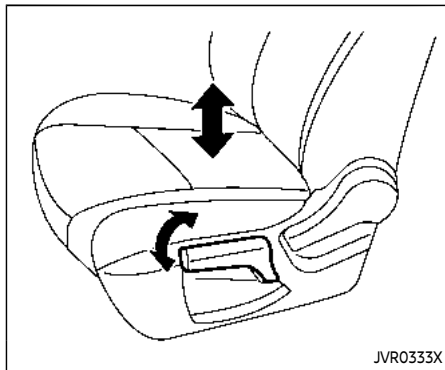

See "Memory seat" (P.3-37) for the seat position memory function (if so equipped).

Seat lifter (if so equipped):

Pull up or push down the adjusting lever to adjust the seat height until the desired position is achieved.

Front power seat adjustment

Operating tips:

- The power seat motor has an auto-reset overload protection circuit. If the motor stops during the seat adjustment, wait 30 seconds, then reactivate the switch.
- To avoid discharge of the battery, do not operate the power seats for a long period of time when the engine is not running.

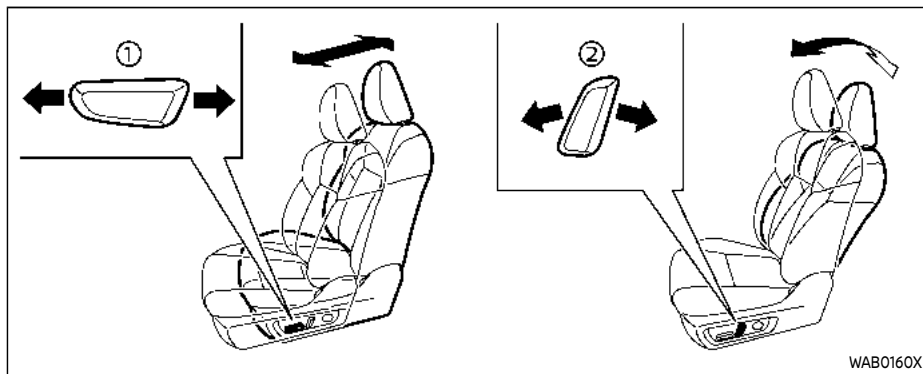

WAB0160X

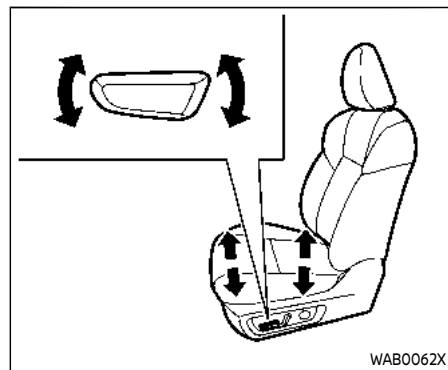

WAB0062X

Forward and backward:

Move forward or backward the adjusting switch ① to the desired position.

Reclining:

Move forward or backward the adjusting switch ② to the desired position.

The reclining feature allows the adjustment of the seatback for occupants of different sizes to help obtain the proper seat belt fit. (See "Seat belts" (P.1-15).)

The seatback may be reclined to allow occupants to rest when the vehicle is parked.

Seat lifter (if so equipped):

Move the switch as shown to adjust the angle of the front portion or height of the seat.

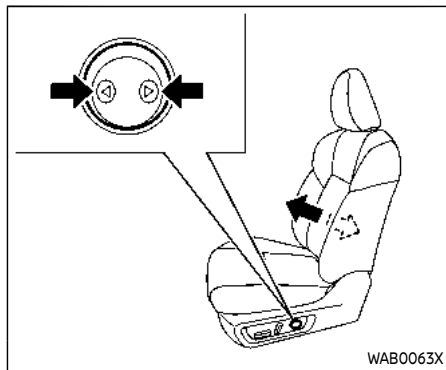

Lumbar support (if so equipped)

The lumbar support feature provides lower back support to the driver.

Push the switch as shown to adjust the seat lumbar area until the desired position is achieved.

NOTE:

The motor of the lumbar support will continue to run while the switch is pushed even after full travel in both directions is achieved.



REAR SEATS

Reclining (if so equipped)

1. Pull up the lever **A**.
2. Tilt the seatback backward. It is reclined slightly.
3. Release the lever to lock the seatback in position.

Folding

Before folding the rear seats

- Secure the outer seat belt on the seat belt hook. (See "Seat belt hook" (P.1-21).)

- If the rear seat is equipped with the head restraints/headrests, slide the front seat forward to make enough room behind the seat so that the rear seatback can be folded flat.
- Remove drink containers from the rear cup holder.



To fold down the seatback

- Pull up the lever **A** and fold the seatback flat.

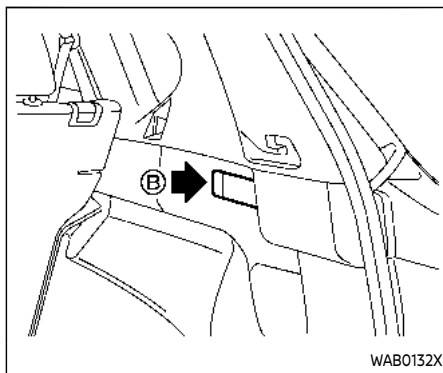

- Pull the lever **B** (if so equipped) located on the side of the luggage area.

To return the seatback

To return the seatback to a seating position, raise the seatback until it latches in place.

When returning the seatback, make sure that the seat belts are not interfering with the seatback latch mechanism.



WARNING

- **Never allow anyone to ride in the cargo area or on the rear seats**

when they are in the fold-down position. In a collision, people riding in these areas without proper restraints are more likely to be seriously injured or killed.

- Do not allow people to ride in any area of your vehicle that is not equipped with seats and seat belts. Be sure everyone in your vehicle is in a seat and using a seat belt properly.
- Do not allow more than one person to use the same seat belt.
- Do not fold down the rear seats when occupants are in the rear seat area or any luggage is on the rear seats.
 - Make sure that the seat path is clear before moving the seat.
 - Be careful not to allow hands or feet to get caught or pinched in the seat.
- Head restraints/headrests should be adjusted properly as they may provide significant protection against injury in an accident. Always replace and adjust them properly if they have been removed for any reason.

- If the head restraints/headrests are removed for any reason, they should be securely stored to prevent them from causing injury to passengers or damage to the vehicle in case of sudden braking or an accident.
- When returning the seatbacks to the upright position, be certain they are completely secured in the latched position. If they are not completely secured, passengers may be injured in an accident or sudden stop.
- Properly secure all cargo to help prevent it from sliding or shifting. Do not place cargo higher than the seatbacks. In a sudden stop or collision, unsecured cargo could cause personal injury.



WARNING

- After adjustment, gently rock in the seat to make sure it is securely locked.
- Do not ride in a moving vehicle when the seatback is reclined. This can be dangerous. The shoulder belt will not be against

your body. In an accident, you could be thrown into it and receive neck or other serious injuries. You could also slide under the lap belt and receive serious internal injuries.

- For the most effective protection when the vehicle is in motion, the seat should be upright. Always sit well back and upright in the seat with both feet on the floor and adjust the seat belt properly. (See "Precautions on seat belt usage" (P.1-15).)

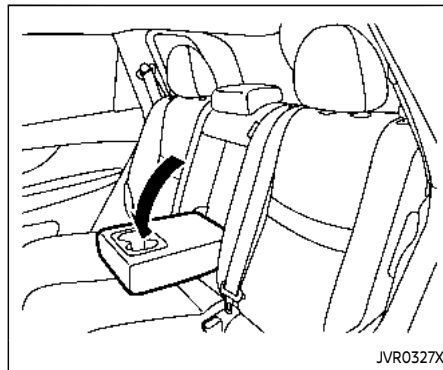

JVR0327X

Rear seats

ARMREST

Pull the armrest down as shown.

HEAD RESTRAINTS/HEADRESTS



WARNING

Head restraint/headrest supplement the other vehicle safety systems. They may provide additional protection against injury in certain rear end collisions. Adjustable head restraints/headrests must be adjusted properly, as specified in this section. Check the adjustment after someone else uses the seat. Do not attach anything to the head restraint/headrest stalks or remove the head restraint/headrest. Do not use the seat if the head restraint/headrest has been removed. If the head restraint/headrest was removed, reinstall and properly adjust the head restraint/headrest before an occupant uses the seating position. Failure to follow these instructions can reduce the effectiveness of the head restraint/headrest. This may increase the risk of serious injury or death in a collision.

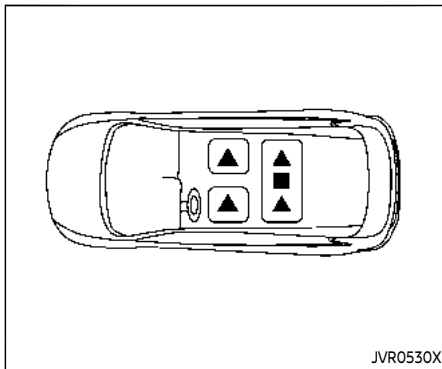

The illustration shows the seating positions equipped with head restraint/headrest.

▲ Indicates the seating position is equipped with a head restraint.

■ Indicates the seating position is equipped with a headrest.

+ Indicates the seating position is not equipped with a head restraint or headrest.

- Your vehicle is equipped with a head restraint/headrest that may be integrated, adjustable or non-adjustable.
- Adjustable head restraints/headrests have multiple notches along the stalk to lock them in a desired adjustment

position.

- The non-adjustable head restraints/headrests have a single locking notch to secure them to the seat frame.
- Proper Adjustment:
 - For the adjustable type, align the head restraint/headrest so the center of your ear is approximately level with the center of the head restraint/headrest.
 - If your ear position is still higher than the recommended alignment, place the head restraint/headrest at the highest position.
- If the head restraint/headrest has been removed, ensure that it is reinstalled and locked in place before riding in that designated seating position.

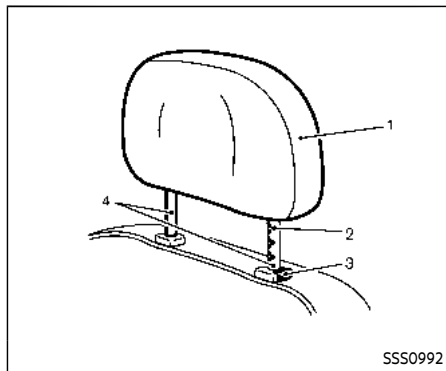

ADJUSTABLE HEAD RESTRAINT/ HEADREST COMPONENTS

1. Removable head restraint/headrest
2. Multiple notches
3. Lock knob
4. Stalks

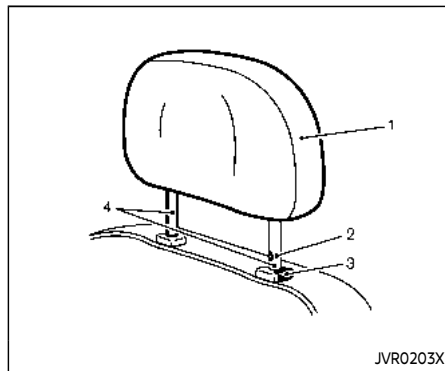

NON-ADJUSTABLE HEAD RE- STRAINT/HEADREST COMPONENTS

1. Removable head restraint/headrest
2. Single notch
3. Lock knob
4. Stalks

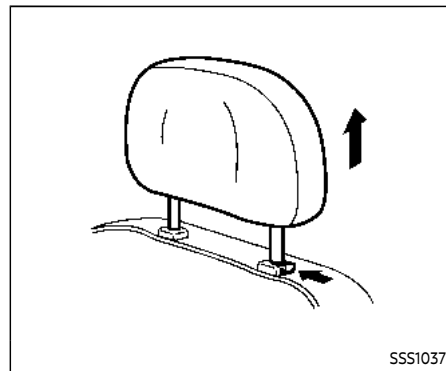

REMOVE

Use the following procedure to remove the head restraint/headrest.

1. Pull the head restraint/headrest up to the highest position.
2. Push and hold the lock knob.
3. Remove the head restraint/headrest from the seat.
4. Store the head restraint/headrest properly in a secure place so it is not loose in the vehicle.
5. Reinstall and properly adjust the head restraint/headrest before an occupant uses the seating position.

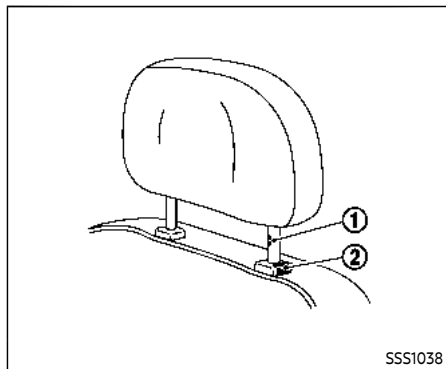

INSTALL

1. Align the head restraint/headrest stalks with the holes in the seat. Make sure that the head restraint/headrest is facing the correct direction. The stalk with the adjustment notch ① must be installed in the hole with the lock knob ②.
2. Push and hold the lock knob and push the head restraint/headrest down.
3. Properly adjust the head restraint/headrest before an occupant uses the seating position.

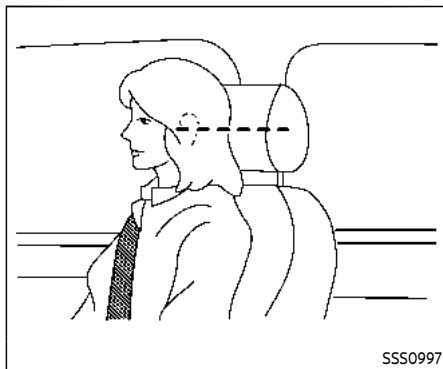

ADJUST

For adjustable head restraint/headrest

Adjust the head restraint/headrest so the center is level with the center of your ears. If your ear position is still higher than the recommended alignment, place the head restraint/headrest at the highest position.

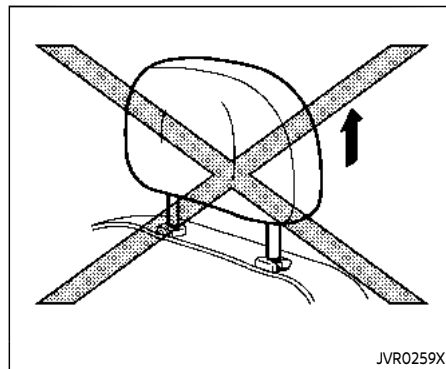

For non-adjustable head restraint/headrest

Make sure the head restraint/headrest is positioned so the lock knob is engaged in the notch before riding in that designated seating position.

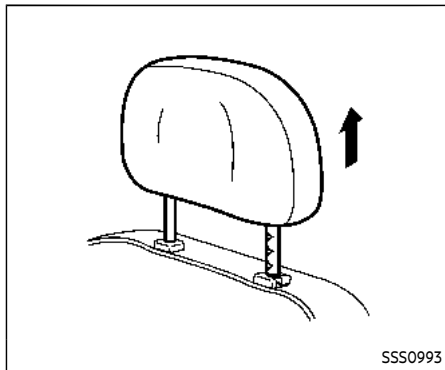

Raise

To raise the head restraint/headrest, pull it up.

Make sure the head restraint/headrest is positioned so the lock knob is engaged in the notch before riding in that designated seating position.

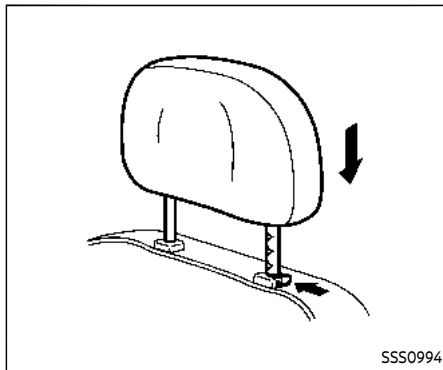

Lower

To lower, push and hold the lock knob and push the head restraint/headrest down.

Make sure the head restraint/headrest is positioned so the lock knob is engaged in the notch before riding in that designated seating position.

SEAT BELTS

PRECAUTIONS ON SEAT BELT USAGE

If you are wearing your seat belt properly adjusted, and you are sitting upright and well back in your seat with both feet on the floor, your chances of being injured or killed in an accident and/or the severity of injury may be greatly reduced. NISSAN strongly encourages you and all of your passengers to buckle up every time you drive, even if your seating position includes a supplemental air bag.

Most U.S. states and Canadian provinces or territories specify that seat belts be worn at all times when a vehicle is being driven.

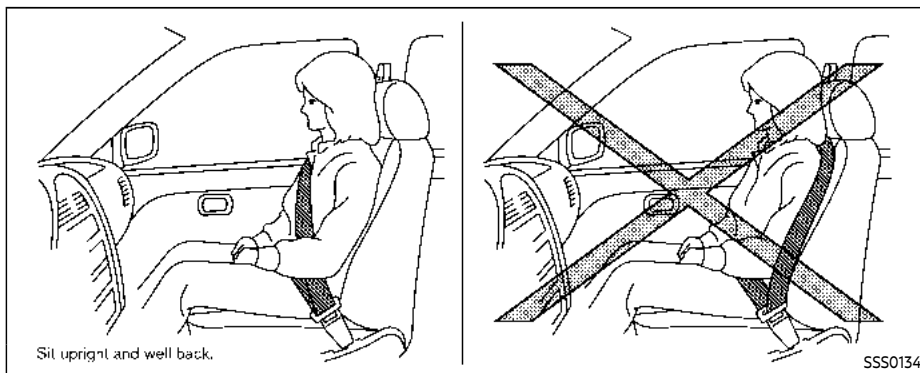
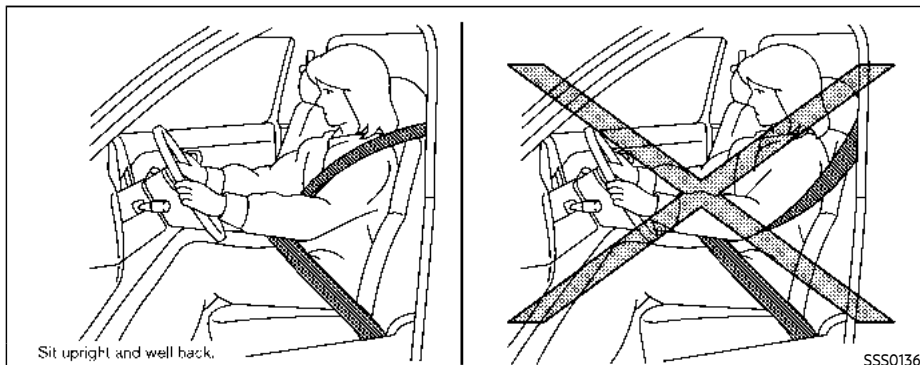

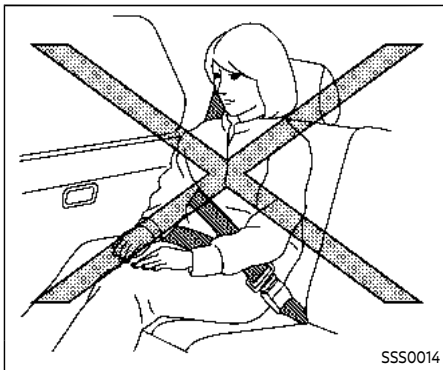
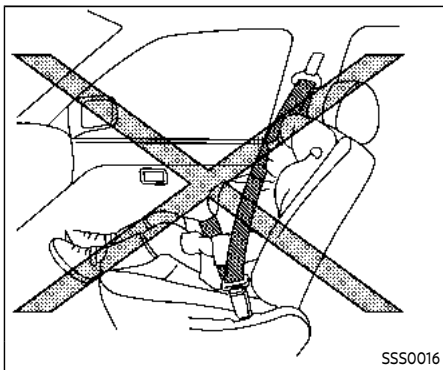

WARNING

- Every person who drives or rides in this vehicle should use a seat belt at all times. Children should be properly restrained in the rear seat and, if appropriate, in a child restraint.
 - The seat belt should be properly adjusted to a snug fit. Failure to do so may reduce the effectiveness of the entire restraint system and increase the chance or severity of injury in an accident. Serious injury or death can occur if the seat belt is not worn properly.
 - Always route the shoulder belt over your shoulder and across your chest. Never put the belt behind your back, under your arm or across your neck. The belt should be away from your face and neck, but not falling off your shoulder.
 - Position the lap belt as low and snug as possible **AROUND THE HIPS, NOT THE WAIST**. A lap belt worn too high could increase the risk of internal injuries in an accident.
- Be sure the seat belt tongue is securely fastened to the proper buckle.
 - Do not wear the seat belt inside out or twisted. Doing so may reduce its effectiveness.
 - Do not allow more than one person to use the same seat belt.
 - Never carry more people in the vehicle than there are seat belts.
 - If the seat belt warning light glows continuously while the ignition is turned ON with all doors closed and all seat belts fastened, it may indicate a malfunction in the system. Have the system checked. It is recommended you visit a NISSAN dealer for this service.
 - No changes should be made to the seat belt system. For example, do not modify the seat belt, add material, or install devices that may change the seat belt routing or tension. Doing so may affect the operation of the seat belt system. Modifying or tampering with the seat belt system may result in serious personal injury.

- **Once a seat belt pretensioner has activated, it cannot be reused and must be replaced together with the retractor. It is recommended you visit a NISSAN dealer for this service.**
- **All seat belt assemblies, including retractors and attaching hardware, should be inspected after any collision. It is recommended you visit a NISSAN dealer for this service. NISSAN recommends that all seat belt assemblies in use during a collision be replaced unless the collision was minor and the belts show no damage and continue to operate properly. Seat belt assemblies not in use during a collision should also be inspected and replaced if either damage or improper operation is noted.**
- **All child restraints and attaching hardware should be inspected after any collision. Always follow the restraint manufacturer's inspection instructions and replacement recommendations. The child restraints should be replaced if they are damaged.**



SEAT BELT WARNING LIGHT AND CHIME

The driver and front passenger seats are equipped with an enhanced seat belt reminder function. If your vehicle is equipped with an enhanced seat belt reminder function, a visual and audible alert will operate if a driver or front passenger seat belt is unbuckled at speeds of approximately 10 MPH (15 km/h) or more under the following conditions:

- If the driver seat belt is not fastened.
- The front passenger's seat belt is not fastened and the seat is occupied by a passenger for 7 seconds after the

ignition switch is placed in the ON position.

- The front passenger's seat belt is not fastened and objects or external force on the passenger seat change the seat belt reminder classification to "occupied".

The seat belt warning light will flash under the conditions shown above until the necessary seat belt is securely fastened.

A warning chime will sound for approximately 95 seconds or until one of the following conditions is met:

- The unbuckled front passenger's seat belt is securely fastened.
- The seat belt reminder function in the front passenger seat no longer detects that the front passenger seat is occupied.
- The ignition switch is turned off.

The below situations could result in the seat belt warning light being illuminated and the chime sounding, even with no occupant present in the passenger seat:

- Heavy objects placed on the seat.
- Someone pushing or pulling on the front passenger seat.
- An object placed under the front passenger seat.

- An object placed between the seat cushion and center console or between the seat cushion and the door.
- An object hanging on the seat or placed in the seatback pocket.
- A child restraint or other object pressing against the rear of the seatback.

The rear seats may be equipped with a seat belt warning in the vehicle information display. (See “11. Rear seat belt warning” (P.2-36).)

PREGNANT WOMEN

NISSAN recommends that pregnant women use seat belts. The seat belt should be worn snug, and always position the lap belt as low as possible around the hips, not the waist. Place the shoulder belt over your shoulder and across your chest. Never put the lap/shoulder belt over your abdominal area. Contact your doctor for specific recommendations.

INJURED PERSONS

NISSAN recommends that injured persons use seat belts, depending on the injury. Check with your doctor for specific recommendations.

THREE-POINT TYPE SEAT BELT WITH RETRACTOR



WARNING

- **Every person who drives or rides in this vehicle should use a seat belt at all times. Children should be in the rear seats and in an appropriate restraint.**
- **Do not ride in a moving vehicle when the seatback is reclined. This can be dangerous. The shoulder belt will not be against your body. In an accident, you could be thrown into it and receive neck or other serious injuries. You could also slide under the lap belt and receive serious internal injuries.**
- **For the most effective protection when the vehicle is in motion, the seat should be upright. Always sit well back and upright in the seat with both feet on the floor and adjust the seat belt properly.**
- **Do not allow children to play with the seat belts. Most seating positions are equipped with Automatic Locking Retractor (ALR) mode seat belts. If the seat belt**

becomes wrapped around a child's neck with the ALR mode activated, the child can be seriously injured or killed if the seat belt retracts and becomes tight. This can occur even if the vehicle is parked. Unbuckle the seat belt to release the child. If the seat belt can not be unbuckled or is already unbuckled, release the child by cutting the seat belt with a suitable tool (such as a knife or scissors) to release the seat belt.

Fastening the seat belts

1. Adjust the seat. (See “Seats” (P.1-3).)



2. Slowly pull the seat belt out of the retractor and insert the tongue into the buckle (A) until you hear and feel the latch engage.

- **The retractor is designed to lock during a sudden stop or on impact. A slow pulling motion permits the belt to move and allows you some freedom of movement in the seat.**
- **If the seat belt cannot be pulled from its fully retracted position, firmly pull the belt and release it. Then smoothly pull the belt out of the retractor.**

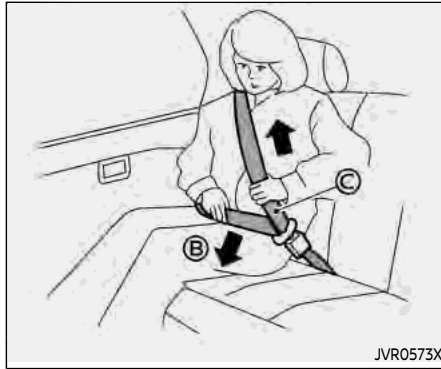

3. Position the lap belt portion **low and snug on the hips** (B) as shown.
4. Pull the shoulder belt portion toward the retractor to take up extra slack (C). Be sure the shoulder belt is routed over your shoulder and across your chest.

The three-point seat belts in the front passenger seat and the rear seating positions have two modes of operation:

- Emergency Locking Retractor (ELR)
 - Automatic Locking Retractor (ALR)
- The Emergency Locking Retractor (ELR) mode allows the seat belt to extend and retract to allow the driver and passengers some freedom of movement in the seat.

The ELR locks the seat belt when the vehicle slows down rapidly or during certain impacts.

The Automatic Locking Retractor (ALR) mode (child restraint mode) locks the seat belt for child restraint installation.

When ALR mode is activated the seat belt cannot be extended again until the seat belt tongue is detached from the buckle and fully retracted. The seat belt returns to the ELR mode after the seat belt fully retracts. For additional information, see "Child restraints" (P.1-25).

The ALR mode should be used only for child restraint installation. During normal seat belt use by an occupant, the ALR mode should not be activated. If it is activated, it may cause uncomfortable seat belt tension. It can also change the operation of the front passenger air bag.



WARNING

When fastening the seat belts, be certain that seatbacks are completely secured in the latched position. If they are not completely secured, passengers may be injured in an accident or sudden stop.

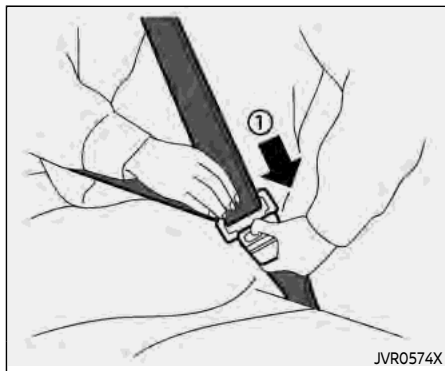

- Grasp the shoulder belt and pull forward quickly. The retractor should lock and restrict further belt movement.

If the retractor does not lock during this check, get the system checked. It is recommended you visit a NISSAN dealer for this service, or to learn more about seat belt operation.

Unfastening the seat belts

To unfasten the seat belt, push the button on the buckle ①. The seat belt automatically retracts.

Checking seat belt operation

Seat belt retractors are designed to lock seat belt movement by two separate methods:

- When the belt is pulled quickly from the retractor.
- When the vehicle slows down rapidly.

To increase your confidence in the seat belts, check the operation as follows:

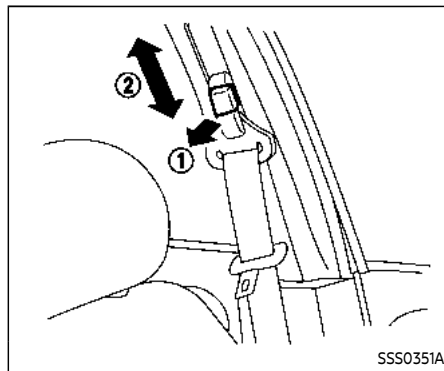

Shoulder belt height adjustment (for front seats)

The shoulder belt anchor height should be adjusted to the position best for you. (See "Precautions on seat belt usage" (P.1-15).)

To adjust, pull the adjustment button ①, and then move the shoulder belt anchor to the desired position ②, so that the belt passes over the center of the shoulder. The belt should be away from your face and neck, but not falling off of your shoulder. Release the adjustment button to lock the shoulder belt anchor into position.

The range of height adjustment of the

shoulder belt may vary depending on the model.

WARNING

- After adjustment, release the adjustment button and try to move the shoulder belt anchor up and down to make sure it is securely fixed in position.
- The shoulder belt anchor height should be adjusted to the position best for you. Failure to do so may reduce the effectiveness of the entire restraint system and increase the chance or severity of injury in an accident.

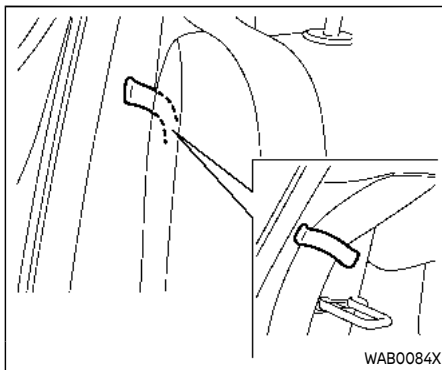

Seat belt hook

When the seat belt is not in use and when folding down the rear seats, hook the rear outer seat belts on the seat belt hooks.

WARNING

Before folding up the rear seats, ensure the seat belts are not obstructing the rear seatback latches to avoid damage to the seat belt webbing.

SEAT BELT EXTENDERS

If, because of body size or driving position, it is not possible to properly fit the lap/shoulder belt and fasten it, an extender that is compatible with the installed seat belts is available that can be purchased. The extender adds approximately 8 in (200 mm) of length and may be used for either the driver or front passenger seating position. It is recommended you visit a NISSAN dealer for assistance with purchasing an extender if an extender is required.

WARNING

- It is recommended that only **NISSAN seat belt extenders, made by the same company which made the original equipment seat belts, be used with NISSAN seat belts.**
- Adults and children who can use the standard seat belt should not use an extender. Such unnecessary use could result in serious personal injury in the event of an accident.
- Never use seat belt extenders to install child restraints. If the child restraint is not secured properly,

the child could be seriously injured or killed in a collision or a sudden stop.

SEAT BELT MAINTENANCE

- **To clean the seat belt webbing**, apply a mild soap solution or any solution recommended for cleaning upholstery or carpets. Then wipe with a cloth and allow the seat belts to dry in the shade. Do not allow the seat belts to retract until they are completely dry.
- **If dirt builds up in the shoulder belt guide** of the seat belt anchors, the seat belts may retract slowly. Wipe the shoulder belt guide with a clean, dry cloth.
- **Periodically check to see that the seat belt and the metal components**, such as buckles, tongues, retractors, flexible wires and anchors, work properly. If loose parts, deterioration, cuts or other damage on the webbing is found, the entire seat belt assembly should be replaced.

CHILD SAFETY



WARNING

Do not allow children to play with the seat belts. Most seating positions are equipped with Automatic Locking Retractor (ALR) mode seat belts. If the seat belt becomes wrapped around a child's neck with the ALR mode activated, the child can be seriously injured or killed if the seat belt retracts and becomes tight. This can occur even if the vehicle is parked. Unbuckle the seat belt to release the child. If the seat belt can not be unbuckled or is already unbuckled, release the child by cutting the seat belt with a suitable tool (such as a knife or scissors) to release the seat belt.

Children need adults to help protect them.

They need to be properly restrained.

In addition to the general information in this manual, child safety information is available from many other sources, including doctors, teachers, government traffic safety offices, and community organizations. Every child is different, so be sure to learn the best way to transport your child.

There are three basic types of child restraint systems:

- Rear-facing child restraint
- Forward-facing child restraint
- Booster seat

The proper restraint depends on the child's size. Generally, infants up to about 1 year and less than 20 lbs (9 kg) should be placed in rear-facing child restraints. Forward-facing child restraints are available for children who outgrow rear-facing child restraints and are at least 1 year old. Booster seats are used to help position a vehicle lap/shoulder belt on a child who can no longer use a forward-facing child restraint.



WARNING

Infants and children need special protection. The vehicle's seat belts may not fit them properly. The shoulder belt may come too close to the face or neck. The lap belt may not fit over their small hip bones. In an accident, an improperly fitting seat belt could cause serious or fatal injury. Always use appropriate child restraints.

All U.S. states and Canadian provinces or

territories require the use of approved child restraints for infants and small children. See “Child restraints” (P.1-25).

A child restraint may be secured in the vehicle by using either the LATCH (Lower Anchors and Tethers for Children) system or with the vehicle seat belt. See “Child restraints” (P.1-25) for more information.

NISSAN recommends that all pre-teens and children be restrained in the rear seat. Studies show that children are safer when properly restrained in the rear seat than in the front seat.

This is especially important because your vehicle has a supplemental restraint system (Air bag system) for the front passenger. See “Supplemental Restraint System (SRS)” (P.1-47).

INFANTS

Infants up to at least 1 year old should be placed in a rear-facing child restraint. NISSAN recommends that infants be placed in child restraints that comply with Federal Motor Vehicle Safety Standards or Canadian Motor Vehicle Safety Standards. You should choose a child restraint that fits your vehicle and always follow the manufacturer’s instructions for installation and use.

SMALL CHILDREN

Children that are over 1 year old and weigh at least 20 lbs (9 kg) should remain in a rear-facing child restraint as long as possible up to the height or weight limit of the child restraint. Children who outgrow the height or weight limit of the rear-facing child restraint and are at least 1 year old should be secured in a forward-facing child restraint with a harness. Refer to the manufacturer’s instructions for minimum and maximum weight and height recommendations. NISSAN recommends that small children be placed in child restraints that comply with Federal Motor Vehicle Safety Standards or Canadian Motor Vehicle Safety Standards. You should choose a child restraint that fits your vehicle and always follow the manufacturer’s instructions for installation and use.

LARGER CHILDREN

Children should remain in a forward-facing child restraint with a harness until they reach the maximum height or weight limit allowed by the child restraint manufacturer.

Once a child outgrows the height or weight limit of the harness-equipped forward-facing child restraint, NISSAN recommends that the child be placed in a commercially available booster seat to

obtain proper seat belt fit. For a seat belt to fit properly, the booster seat should raise the child so that the shoulder belt is properly positioned across the chest and the top, middle portion of the shoulder. The shoulder belt should not cross the neck or face and should not fall off the shoulder. The lap belt should lie snugly across the lower hips or upper thighs, not the abdomen.

A booster seat can only be used in seating positions that have a three-point type seat belt. The booster seat should fit the vehicle seat and have a label certifying that it complies with Federal Motor Vehicle Safety Standards or Canadian Motor Vehicle Safety Standards.

A booster seat should be used until the child can pass the seat belt fit test below:

- Are the child’s back and hips against the vehicle seatback?
- Is the child able to sit without slouching?
- Do the child’s knees bend easily over the front edge of the seat with feet flat on the floor?
- Can the child safely wear the seat belt (lap belt low and snug across the hips and shoulder belt across mid-chest and shoulder)?

- Is the child able to use the properly adjusted head restraint/headrest?
- Will the child be able to stay in position for the entire ride?

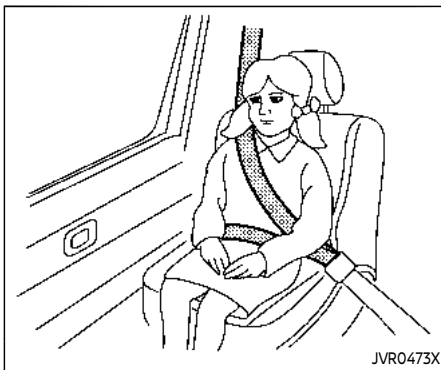

seriously injured or killed in a sudden stop or collision.

If you answered no to any of these questions, the child should remain in a booster seat using a three-point type seat belt.

NOTE:

Laws in some communities may follow different guidelines. Check local and state regulations to confirm your child is using the correct restraint system before traveling.



WARNING

Never let a child stand or kneel on any seat and do not allow a child in the cargo area. The child could be

CHILD RESTRAINTS

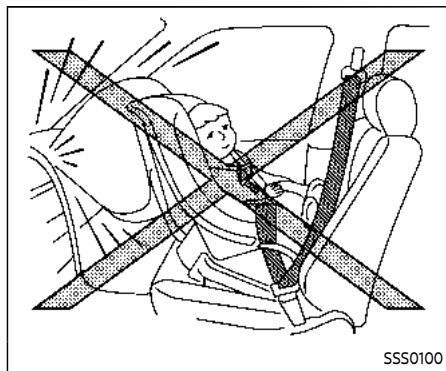
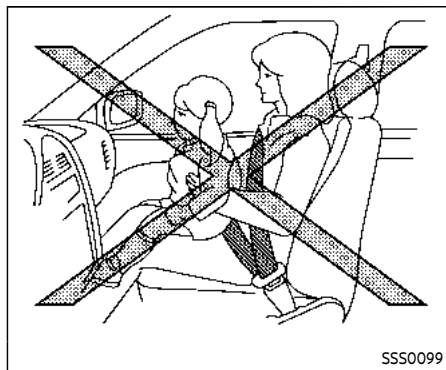

PRECAUTIONS ON CHILD RESTRAINTS

WARNING

- Failure to follow the warnings and instructions for proper use and installation of child restraints could result in serious injury or death of a child or other passengers in a sudden stop or collision:
 - The child restraint must be used and installed properly. Always follow all of the child restraint manufacturer's instructions for installation and use.
 - Infants and children should never be held on anyone's lap. Even the strongest adult cannot resist the forces of a collision.
 - Do not put a seat belt around both a child and another passenger.
 - NISSAN recommends that all child restraints be installed in the rear seat. Studies show that children are safer when properly restrained in the rear

seat than in the front seat. If you must install a forward-facing child restraint in the front seat, see "Forward-facing child restraint installation using the seat belts" (P.1-39).

- Even with the NISSAN Advanced Air Bag System, never install a rear-facing child restraint in the front seat. An inflating air bag could seriously injure or kill a child. A rear-facing child restraint must only be used in the rear seat.
- Be sure to purchase a child restraint that will fit the child and vehicle. Some child restraints may not fit properly in your vehicle.
- Child restraint anchorages are designed to withstand only those loads imposed by correctly fitted child restraints. Under no circumstances are they to be used to attach adult seat belts, or other items or equipment to the vehicle. Doing so could damage the child restraint anchorages. The child restraint

will not be properly installed using the damaged anchorage, and a child could be seriously injured or killed in a collision.

- Never use the anchor points for adult seat belts or harnesses.
- A child restraint with a top tether strap should not be used in the front passenger seat.
- Keep seatbacks as upright as possible after fitting the child restraint.
- Infants and children should always be placed in an appropriate child restraint while in the vehicle.
- When the child restraint is not in use, keep it secured with the LATCH system or a seat belt. In a sudden stop or collision, loose objects can injure occupants or damage the vehicle.



CAUTION

A child restraint in a closed vehicle can become very hot. Check the seating surface and buckles before placing a child in the child restraint.

This vehicle is equipped with a universal child restraint anchor system, referred to as the LATCH (Lower Anchors and Tethers for CHildren) system. Some child restraints include rigid or webbing-mounted attachments that can be connected to these anchors.

For details, see “Lower Anchors and Tethers for CHildren (LATCH) system” (P.1-27).

If you do not have a LATCH compatible child restraint, the vehicle seat belts can be used.

Several manufacturers offer child restraints for infants and small children of various sizes. When selecting any child restraint, keep the following points in mind:

- Choose only a restraint with a label certifying that it complies with Federal Motor Vehicle Safety Standard 213 or Canadian Motor Vehicle Safety Standard 213.

- Check the child restraint in your vehicle to be sure it is compatible with the vehicle’s seat and seat belt system.
- If the child restraint is compatible with your vehicle, place your child in the child restraint and check the various adjustments to be sure the child restraint is compatible with your child. Choose a child restraint that is designed for your child’s height and weight. Always follow all recommended procedures.
- If the combined weight of the child and child restraint is less than 65 lbs (29.5 kg), you may use either the LATCH anchors or the seat belt to install the child restraint (not both at the same time).
- If the combined weight of the child and child restraint is greater than 65 lbs (29.5 kg), use the vehicle’s seat belt (not the lower anchors) to install the child restraint.
- Be sure to follow the child restraint manufacturer’s instructions for installation.

All U.S. states and Canadian provinces or territories require that infants and small children be restrained in an approved child restraint at all times while the vehicle is being operated. Canadian

law requires the top tether strap on forward-facing child restraints be secured to the designated anchor point on the vehicle.

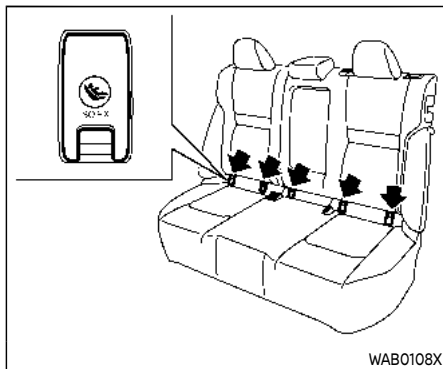

LATCH system anchor location

Lower Anchors and Tethers for Children (LATCH) SYSTEM

Your vehicle is equipped with special anchor points that are used with LATCH system compatible child restraints. This system may also be referred to as the ISOFIX or ISOFIX compatible system. With this system, you do not have to use a vehicle seat belt to secure the child restraint unless the combined weight of the child and child restraint exceeds 65 lbs (29.5 kg). If the combined weight of the child and child restraint is greater than 65 lbs (29.5 kg), use the vehicle's seat belt (not the lower anchors) to install the child restraint. Be sure to follow the child

restraint manufacturer's instructions for installation.

The LATCH anchor points can be used to install child restraints in either of the rear outboard seating positions or in the center rear seating position. Please refer to the following section of this Owner's Manual for specific information about installing a child restraint in the center rear seating position using the LATCH anchors.



CAUTION

Store the loose LATCH covers (for example, in the console box) where they will not get damaged to avoid losing them. (See "Console box" (P.2-79).)

LATCH lower anchor



WARNING

Failure to follow the warnings and instructions for proper use and installation of child restraints could result in serious injury or death of a child or other passengers in a sudden stop or collision:

- Only attach LATCH system compatible child restraints to the Lower Anchors shown in the illustration. For additional information, refer to the following sections of this Owner's Manual for installation guidance.
- Attach LATCH system compatible child restraints only at the locations shown in the illustration.
- Inspect the lower anchors by inserting your fingers into the lower anchor area. Feel to make sure there are no obstructions over the anchors such as seat belt webbing or seat cushion material. The child restraint will not be secured properly if the lower anchors are obstructed.
- Child restraint anchorages are designed to withstand only those loads imposed by correctly fitted child restraints. Under no circumstances are they to be used to attach adult seat belts, or other items or equipment to the vehicle. Doing so could damage the child restraint anchorages. The child restraint will not be properly installed using the damaged anchorage, and a child could be seriously injured or killed in a

collision.

LATCH lower anchor location

The LATCH lower anchor points are provided to install child restraints in the rear seats. **Do not attempt to install child restraints in the center and left outboard seating positions simultaneously using the LATCH lower anchors.**

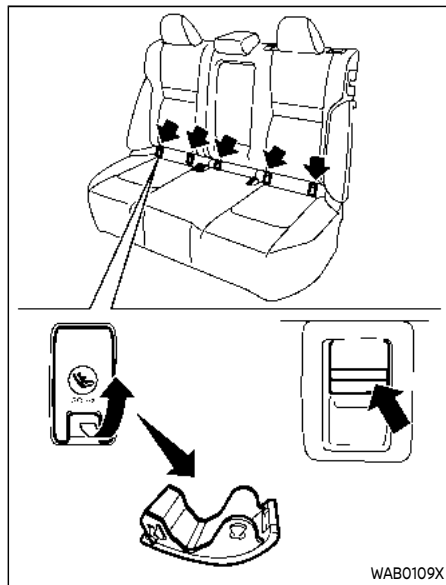

LATCH lower anchor cover removal

The LATCH lower anchor points are located under covers labelled ISOFIX at the bottom of the rear seat cushions. To access a LATCH lower anchor point, insert your finger into the cover and pull the cover off.

CAUTION

Store the loose LATCH covers (for example, in the console box) where they will not get damaged to avoid losing them. (See “Console box” (P.2-79).)

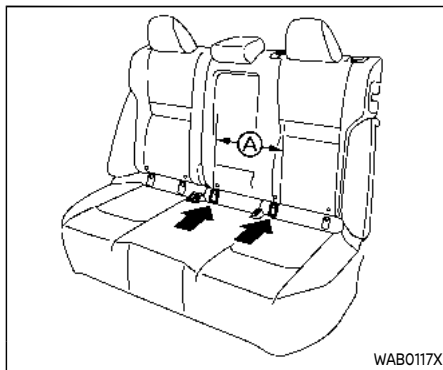

LATCH in the center rear seating position

A 5th LATCH anchor can be found between the outboard LATCH anchor pairs. It is specifically designed to be used together with the inboard LATCH anchor on the driver's side, in order to install a CRS in the rear center seating position.

These anchors utilize standard LATCH anchor spacing, Ⓐ of 11.02 in (280mm).

WARNING

Never attach two CRS attachments to the same LATCH anchor. This may overload the anchor in a collision, which could increase the risk of the occupant's serious injury or death.

When installing the CRS in the center rear seating position with the inboard LATCH anchors, be careful to ensure any occupant or CRS in the outboard seating positions is properly restrained using the vehicle seat belt and there is no interference with the center CRS installation. If the outboard occupants cannot be properly restrained, consider using the vehicle seat belt to restrain the CRS in the center seating position, or moving the CRS to another position instead.

When installing a CRS in the center seating position, use the seat back recline feature to align the left and right sides of the seat back, creating one evenly reclined surface. Never install a CRS in the center seating position when one part of the seat back is further reclined than the other. This may create an unstable surface on which to install the CRS.

Failure to evenly recline the seat backs before CRS installation could increase the risk of the occupant's serious injury or death. Remember to re-check that the CRS is properly installed any time the seats are reclined or adjusted.

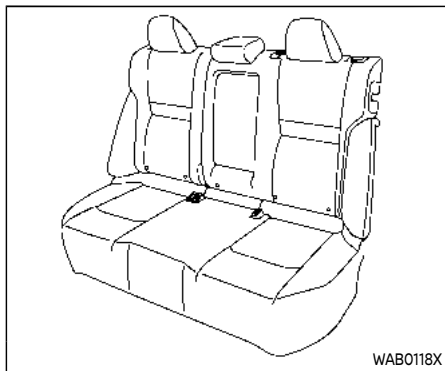

OK (the seatback recline is aligned)

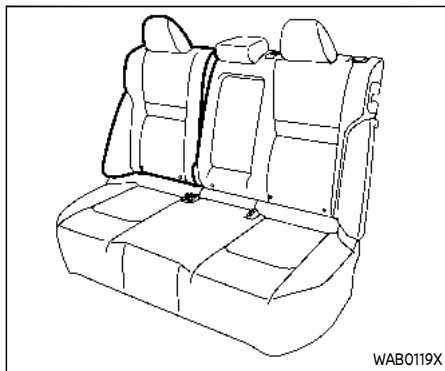

NG (the seatback recline is not aligned)

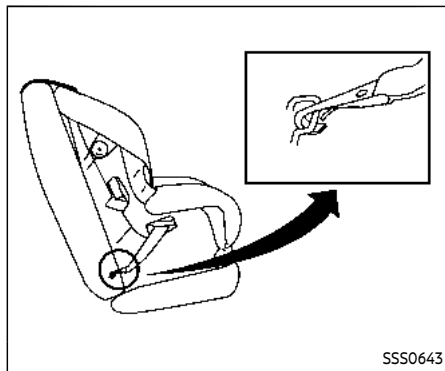

LATCH webbing-mounted attachment

Installing child restraint LATCH lower anchor attachments

LATCH compatible child restraints include two rigid or webbing-mounted attachments that can be connected to two anchors located at certain seating positions in your vehicle. With this system, you do not have to use a vehicle seat belt to secure the child restraint. Check your child restraint for a label stating that it is compatible with LATCH. This information may also be in the instructions provided by the child restraint manufacturer.

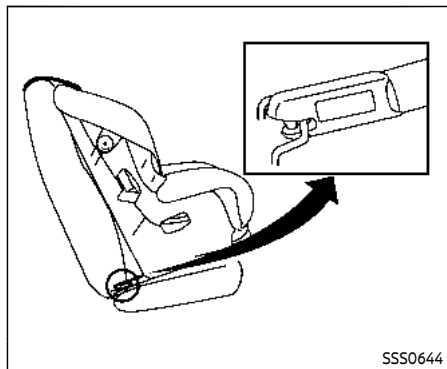

LATCH rigid-mounted attachment

When installing a child restraint, carefully read and follow the instructions in this manual and those supplied with the child restraint.

Top tether anchor

WARNING

Properly secure cargo and do not allow it to contact the top tether strap when it is attached to the top tether anchor. Cargo that is not properly secured or cargo that contacts the top tether strap may damage the top tether strap during a

collision. If the cargo cover (if so equipped) contacts the top tether strap when it is attached to the top tether anchor, remove the cargo cover from the vehicle. If the cargo cover is not removed, it may damage the top tether strap during a collision. Your child could be seriously injured or killed in a collision if the child restraint top tether strap is damaged.

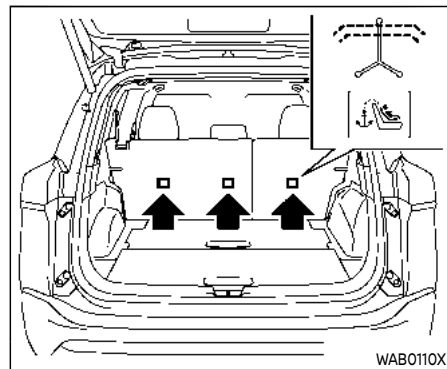

Top tether anchor point locations

WARNING

Child restraint anchorages are designed to withstand only those loads imposed by correctly fitted child restraints. Under no circumstances are they to be used to attach adult seat belts, or other items or equipment to the vehicle. Doing so could damage the child restraint anchorages. The child restraint will not be properly installed using the damaged anchorage, and a child could be seriously injured or killed in a

collision.

Anchor points are located on the back side of the seatbacks.

If a child restraint has a top tether strap, it must be used when installing with the LATCH lower anchor attachments or seat belts as instructed by the child restraint manufacturer.

If you have any questions when installing a top tether strap child restraint on the rear seat, it is recommended you visit a NISSAN dealer for this service.

REAR-FACING CHILD RESTRAINT INSTALLATION USING LATCH

For additional information, refer to all Warnings and Cautions in the "Child safety" and "Child restraints" sections before installing a child restraint.

Do not use the lower anchors if the combined weight of the child and the child restraint exceeds 65 lbs (29.5 kg). If the combined weight of the child and the child restraint is greater than 65 lbs (29.5 kg), use the vehicle's seat belt (not the lower anchors) to install the child restraint. Be sure to follow the child restraint manufacturer's instructions for installation.

Follow these steps to install a rear-facing

child restraint using the LATCH system:

1. Position the child restraint on the seat. Always follow the child restraint manufacturer's instructions.

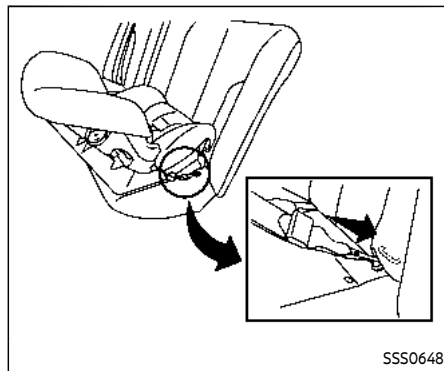

Rear-facing web-mounted — step 2

2. Secure the child restraint anchor attachments to the LATCH lower anchors. Check to make sure the LATCH attachment is properly attached to the lower anchors.

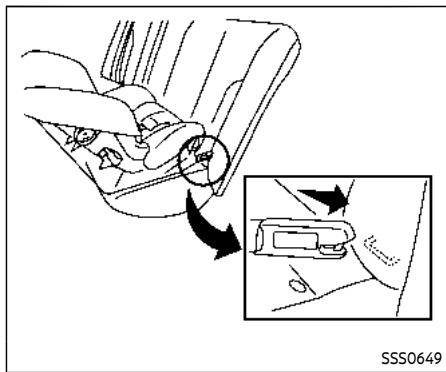

Rear-facing rigid-mounted — step 2

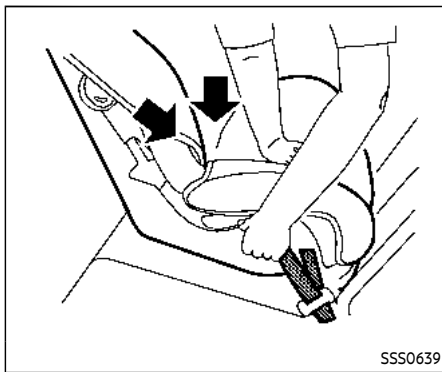

Rear-facing — step 3

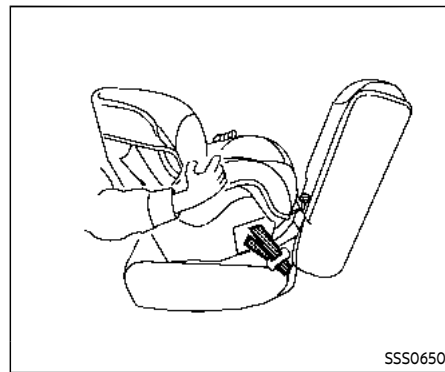

Rear-facing — step 4

3. For child restraints that are equipped with webbing-mounted attachments, remove any additional slack from the anchor attachments. Press downward and rearward firmly in the center of the child restraint with your hand to compress the vehicle seat cushion and seatback while tightening the webbing of the anchor attachments.
4. After attaching the child restraint, test it before you place the child in it. Push it from side to side while holding the child restraint near the LATCH attachment path. The child restraint should not move more than 1 inch (25 mm), from side to side. Try to tug it forward and check to see if the LATCH attachment holds the restraint in place. If the restraint is not secure, tighten the LATCH attachment as necessary, or put the restraint in another seat and test it again. You may need to try a different child restraint or try installing by using the vehicle seat belt (if applicable). Not all child restraints fit

in all types of vehicles.

5. Check to make sure the child restraint is properly secured prior to each use. If the child restraint is loose, repeat steps 1 through 4.

REAR-FACING CHILD RESTRAINT INSTALLATION USING THE SEAT BELTS

WARNING

The three-point seat belt with Automatic Locking Retractor (ALR) must be used when installing a child restraint. Failure to use the ALR mode will result in the child restraint not being properly secured. The restraint could tip over or be loose and cause injury to a child in a sudden stop or collision.

For additional information, refer to all Warnings and Cautions in the "Child safety" and "Child restraints" sections before installing a child restraint.

Do not use the lower anchors if the combined weight of the child and the child restraint exceeds 65 lbs (29.5 kg). If the combined weight of the child and the child restraint is greater than 65 lbs (29.5

kg), use the vehicle's seat belt (not the lower anchors) to install the child restraint. Be sure to follow the child restraint manufacturer's instructions for installation.

Follow these steps to install a rear-facing child restraint using the vehicle seat belts in the rear seats:

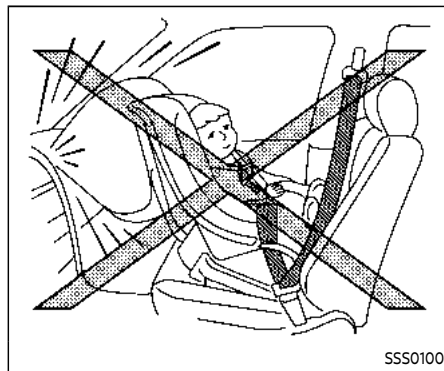

Rear-facing — step 1

1. **Child restraints for infants must be used in the rear-facing direction and therefore must not be used in the front seat.** Position the child restraint on the seat. Always follow the restraint manufacturer's instructions.

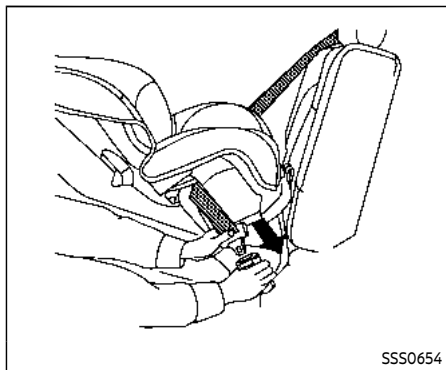

Rear-facing — step 2

2. Route the seat belt tongue through the child restraint and insert it into the buckle until you hear and feel the latch engage. Be sure to follow the child restraint manufacturer's instructions for belt routing.

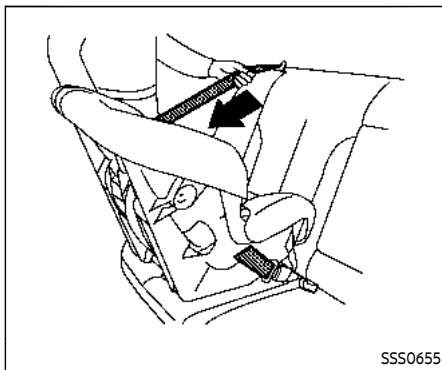

Rear-facing — step 3

3. Pull the shoulder belt until the belt is fully extended. At this time, the seat belt retractor is in the Automatic Locking Retractor (ALR) mode (child restraint mode). It reverts to the Emergency Locking Retractor (ELR) mode when the seat belt is fully retracted.

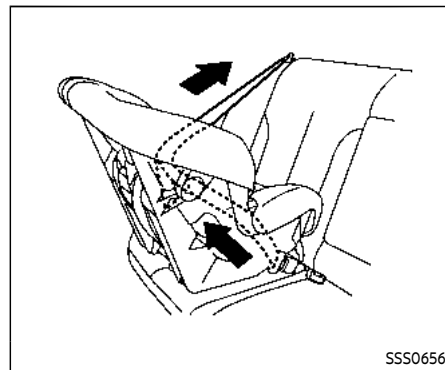

Rear-facing — step 4

4. Allow the seat belt to retract. Pull up on the shoulder belt to remove any slack in the belt.

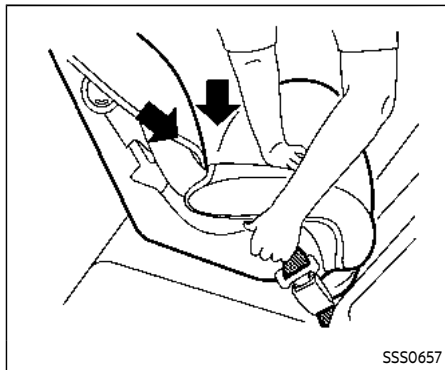

Rear-facing — step 5

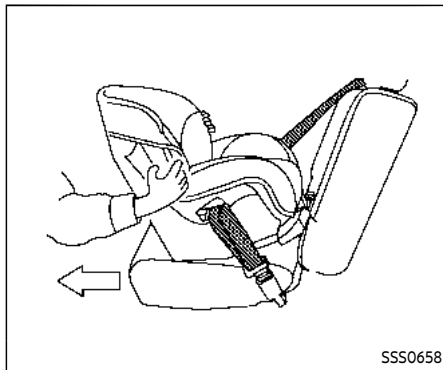

Rear-facing — step 6

5. Remove any additional slack from the seat belt; press downward and rearward firmly in the center of the child restraint to compress the vehicle seat cushion and seatback while pulling up on the seat belt.

6. After attaching the child restraint, test it before you place the child in it. Push it from side to side while holding the child restraint near the seat belt path. The child restraint should not move more than 1 inch (25 mm), from side to side. Try to tug it forward and check to see if the belt holds the restraint in place. If the restraint is not secure, tighten the seat belt as necessary, or put the restraint in another seat and test it again. You may need to try a different child restraint. Not all child restraints fit in all types of vehicles.
7. Check to make sure that the child restraint is properly secured prior to

each use. If the seat belt is not locked, repeat steps 1 through 6.

After the child restraint is removed and the seat belt fully retracted, the ALR mode (child restraint mode) is canceled.

FORWARD-FACING CHILD RESTRAINT INSTALLATION USING LATCH

For additional information, refer to all Warnings and Cautions in the "Child safety" and "Child restraints" sections before installing a child restraint.

Do not use the lower anchors if the combined weight of the child and the child restraint exceeds 65 lbs (29.5 kg). If the combined weight of the child and the child restraint is greater than 65 lbs (29.5 kg), use the vehicle's seat belt (not the lower anchors) to install the child restraint. Be sure to follow the child restraint manufacturer's instructions for installation.

Follow these steps to install a forward-facing child restraint using the LATCH system:

1. Position the child restraint on the seat. Always follow the child restraint manufacturer's instructions.

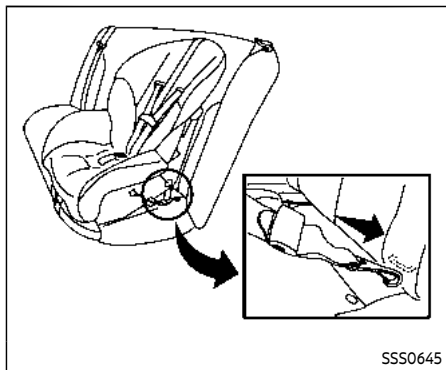

Forward-facing web-mounted – step 2

2. Secure the child restraint anchor attachments to the LATCH lower anchors. Check to make sure the LATCH attachment is properly attached to the lower anchors.

If the child restraint is equipped with a top tether strap, route the top tether strap and secure the tether strap to the tether anchor point. See “Installing top tether strap” (P.1-39). Do not install child restraints that require the use of a top tether strap in seating positions that do not have a top tether anchor.

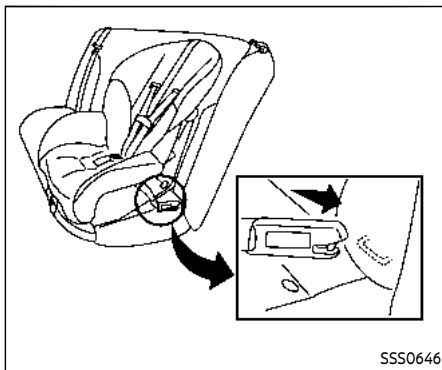

Forward-facing rigid-mounted – step 2

3. The back of the child restraint should be secured against the vehicle seat-back.

If necessary, adjust or remove the head restraint/headrest to obtain the correct child restraint fit. If the head restraint/headrest is removed, store it in a secure place. **Be sure to reinstall the head restraint/headrest when the child restraint is removed.** See “Head restraints/headrests” (P.1-11) for head restraint/headrest adjustment information.

If the seating position does not have an adjustable head restraint/headrest and it is interfering with the proper

child restraint fit, try another seating position or a different child restraint.

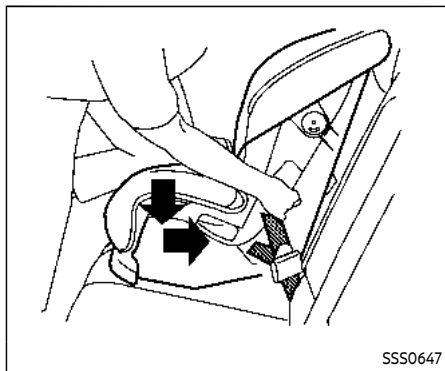

Forward-facing — step 4

SSS0647

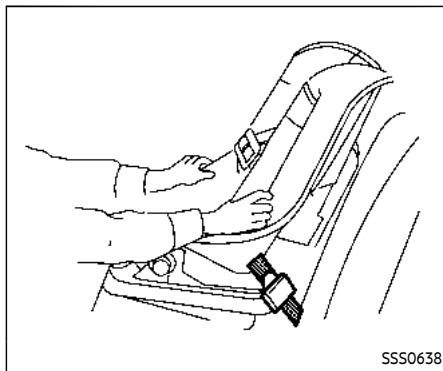

Forward-facing — step 6

SSS0638

- For child restraints that are equipped with webbing-mounted attachments, remove any additional slack from the anchor attachments. Press downward and rearward firmly in the center of the child restraint with your knee to compress the vehicle seat cushion and seatback while tightening the webbing of the anchor attachments.
- Tighten the tether strap according to the manufacturer's instructions to remove any slack.
- After attaching the child restraint, test it before you place the child in it. Push it from side to side while holding the child restraint near the LATCH attachment path. The child restraint should not move more than 1 inch (25 mm), from side to side. Try to tug it forward and check to see if the LATCH attachment holds the restraint in place. If the restraint is not secure, tighten the LATCH attachment as necessary, or put the restraint in another seat and test it again. You may need to try a different child restraint. Not all child restraints fit in all types of vehicles.
- Check to make sure the child restraint is properly secured prior to each use. If the child restraint is loose, repeat steps 1 through 6.

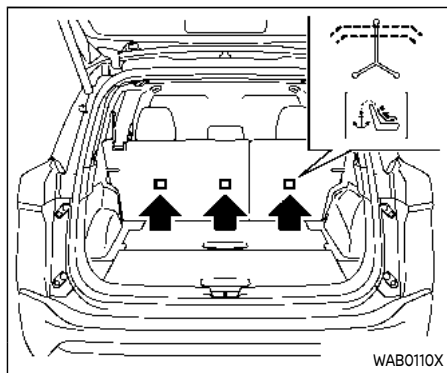

Installing top tether strap

WARNING

- **Child restraint anchorages are designed to withstand only those loads imposed by correctly fitted child restraints. Under no circumstances are they to be used to attach adult seat belts, or other items or equipment to the vehicle. Doing so could damage the child restraint anchorages. The child restraint will not be properly installed using the damaged anchorage, and a child could be**

seriously injured or killed in a collision.

- **Do not hook the top tether strap on the seatback carpet. Be sure to use the tether anchor point to secure the top tether strap.**

The child restraint top tether strap must be used when installing forward-facing child restraint with the LATCH lower anchor attachments.

First, secure the child restraint with the LATCH lower anchors.

1. Remove the head restraint/headrest and store it in a secure place. Be sure to reinstall the head restraint/headrest when the child restraint is removed.
2. Position the top tether strap as shown.
3. Secure the top tether strap to the tether anchor point as shown.
4. Refer to the appropriate child restraint installation procedure steps in this section before tightening the tether strap.

If you have any questions when installing a top tether strap, it is recommended that you visit a NISSAN dealer for this service.

FORWARD-FACING CHILD RESTRAINT INSTALLATION USING THE SEAT BELTS

WARNING

The three-point seat belt with Automatic Locking Retractor (ALR) must be used when installing a child restraint. Failure to use the ALR mode will result in the child restraint not being properly secured. The restraint could tip over or be loose and cause injury to a child in a sudden stop or collision. Also, it can change the operation of the front passenger air bag. See "Front passenger air bag and status light" (P.1-55).

For additional information, refer to all Warnings and Cautions in the "Child safety" and "Child restraints" sections before installing a child restraint.

Do not use the lower anchors if the combined weight of the child and the child restraint exceeds 65 lbs (29.5 kg). If the combined weight of the child and the

child restraint is greater than 65 lbs (29.5 kg), use the vehicle's seat belt (not the lower anchors) to install the child restraint. Be sure to follow the child restraint manufacturer's instructions for installation.

Follow these steps to install a forward-facing child restraint using the vehicle seat belt in the rear seats or in the front passenger seat:

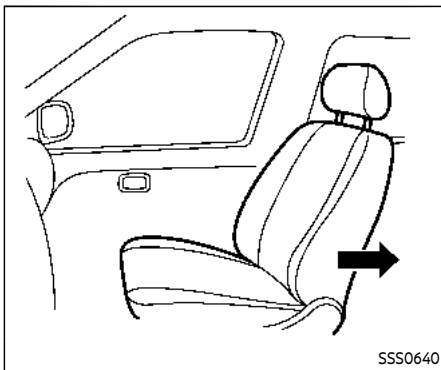

Forward-facing (front passenger seat) — step 1

1. **If you must install a child restraint in the front seat, it should be placed in a forward-facing direction only. Move the seat to the rearmost position. Child restraints for infants must be used in the rear-facing direction and, therefore, must not be used in the front seat.**
2. Position the child restraint on the seat. Always follow the child restraint manufacturer's instructions.
The back of the child restraint should be secured against the vehicle seat-back.
If necessary, adjust or remove the head restraint/headrest to obtain the

correct child restraint fit. If the head restraint/headrest is removed, store it in a secure place. **Be sure to reinstall the head restraint/headrest when the child restraint is removed.** See "Head restraints/headrests" (P.1-11) for head restraint/headrest adjustment, removal and installation information.

If the seating position does not have an adjustable head restraint/headrest and it is interfering with the proper child restraint fit, try another seating position or a different child restraint.

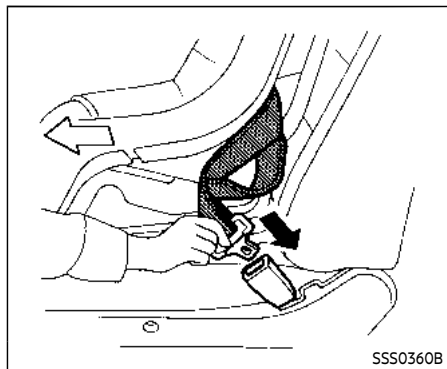

Forward-facing — step 3

3. Route the seat belt tongue through the child restraint and insert it into the buckle until you hear and feel the latch engage. Be sure to follow the child restraint manufacturer's instructions for belt routing.

If the child restraint is equipped with a top tether strap, route the top tether strap and secure the tether strap to the tether anchor point (rear seat installation only). See "Installing top tether strap" (P.1-43). Do not install child restraints that require the use of a top tether strap in seating positions that do not have a top tether anchor.

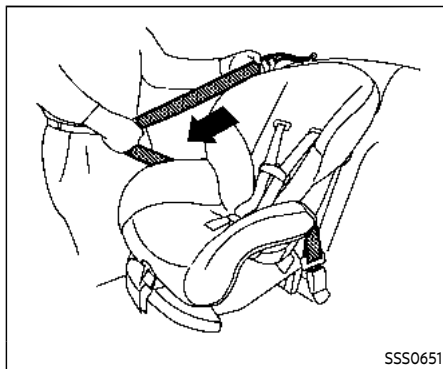

Forward-facing — step 4

4. Pull the shoulder belt until the belt is fully extended. At this time, the seat belt retractor is in the Automatic Locking Retractor (ALR) mode (child restraint mode). It reverts to Emergency Locking Retractor (ELR) mode when the seat belt is fully retracted.

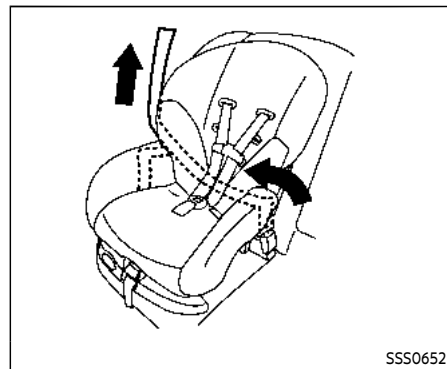

Forward-facing — step 5

5. Allow the seat belt to retract. Pull up on the shoulder belt to remove any slack in the belt.

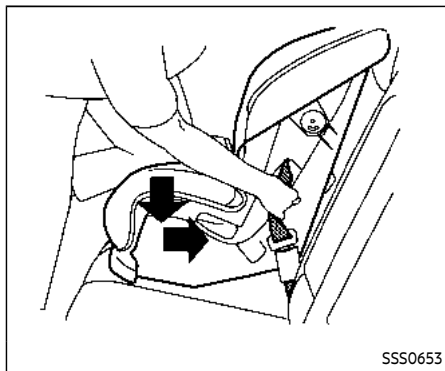

Forward-facing — step 6

SSS0653



Forward-facing — step 8

SSS0641

6. Remove any additional slack from the seat belt; press downward and rearward firmly in the center of the child restraint with your knee to compress the vehicle seat cushion and seatback while pulling up on the seat belt.
7. Tighten the tether strap according to the manufacturer's instructions to remove any slack.
8. After attaching the child restraint, test it before you place the child in it. Push it from side to side while holding the child restraint near the seat belt path. The child restraint should not move more than 1 inch (25 mm), from side to side. Try to tug it forward and check to see if the belt holds the restraint in place. If the restraint is not secure, tighten the seat belt as necessary, or put the restraint in another seat and test it again. You may need to try a different child restraint. Not all child restraints fit in all types of vehicles.
9. Check to make sure the child restraint is properly secured prior to each use. If

the seat belt is not locked, repeat steps 2 through 8.



Forward-facing — step 10

10. If the child restraint is installed in the front passenger seat, place the ignition switch in the ON position. The front passenger air bag status light  should illuminate. If this light is not illuminated, see "Front passenger air bag and status light" (P.1-55). **Move the child restraint to another seating position.** Have the system checked. It is recommended you visit a NISSAN dealer for this service.

After the child restraint is removed and the seat belt is fully retracted, the ALR mode (child restraint mode) is canceled.

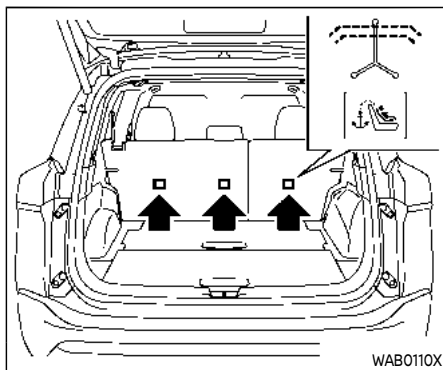

Installing top tether strap

WARNING

- **Child restraint anchorages are designed to withstand only those loads imposed by correctly fitted child restraints. Under no circumstances are they to be used to attach adult seat belts, or other items or equipment to the vehicle. Doing so could damage the child restraint anchorages. The child restraint will not be properly installed using the damaged anchorage, and a child could be**

seriously injured or killed in a collision.

- **Do not hook the top tether strap on the seatback carpet. Be sure to use the tether anchor point to secure the top tether strap.**

The child restraint top tether strap must be used when installing forward-facing child restraint with the seat belts.

First, secure the child restraint with the seat belt.

1. Remove the head restraint/headrest and store it in a secure place. Be sure to reinstall the head restraint/headrest when the child restraint is removed.

See "Head restraints/headrests" (P.1-11) for head restraint/headrest adjustment, removal and installation information.

2. Position the top tether strap as shown.
3. Secure the top tether strap to the tether anchor point as shown.
4. Refer to the appropriate child restraint installation procedure steps in this section before tightening the tether strap.

If you have any questions when instal-

ling a top tether strap, it is recommended you visit a NISSAN dealer for this service.

BOOSTER SEATS

For additional information on installing a booster seat in your vehicle, follow the instructions outlined in this section.

Precautions on booster seats



WARNING

If a booster seat and seat belt are not used properly, the risk of a child being injured or killed in a sudden stop or collision greatly increases:

- Make sure the shoulder portion of the belt is away from the child's face and neck and the lap portion of the belt does not cross the stomach.
- Make sure the shoulder belt is not behind the child or under the child's arm.
- A booster seat must only be installed in a seating position that has a lap/shoulder belt.

Booster seats of various sizes are offered by several manufacturers. When selecting

any booster seat, keep the following points in mind:

- Choose only a booster seat with a label certifying that it complies with Federal Motor Vehicle Safety Standard 213 or Canadian Motor Vehicle Safety Standard 213.
- Check the booster seat in your vehicle to be sure it is compatible with the vehicle's seat and seat belt system.

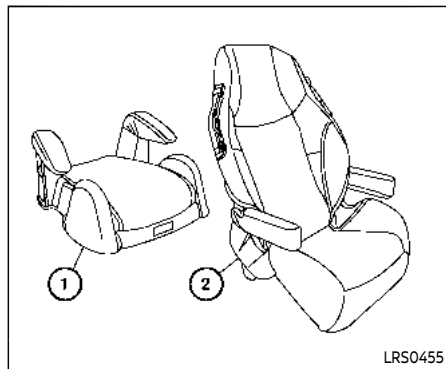
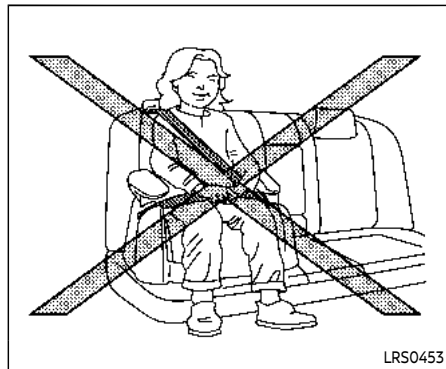

- Make sure the child's head will be properly supported by the booster seat or vehicle seat. The seatback must be at or above the center of the child's ears. For example, if a low back booster seat ① is chosen, the vehicle seatback must be at or above the center of the child's ears. If the seatback is lower than the center of the child's ears, a high back booster seat ② should be used.
- If the booster seat is compatible with your vehicle, place your child in the booster seat and check the various adjustments to be sure the booster seat is compatible with your child. Always follow all recommended procedures.

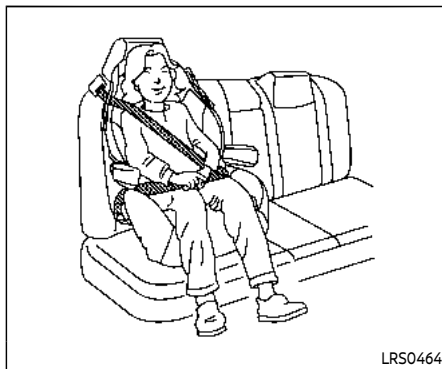

All U.S. states and Canadian provinces or territories require that infants and small children be restrained in an approved child restraint at all times while the vehicle is being operated.

The instructions in this section apply to booster seat installation in the rear seats or the front passenger seat.

Booster seat installation



WARNING

To avoid injury to child, do not use the lap/shoulder belt Automatic Locking Retractor (ALR) mode when

using a booster seat with the seat belts.

For additional information, refer to all Warnings and Cautions in the "Child safety", "Child restraints" and "Booster seats" sections earlier in this section before installing a child restraint.

Follow these steps to install a booster seat in the rear seat or in the front passenger seat:

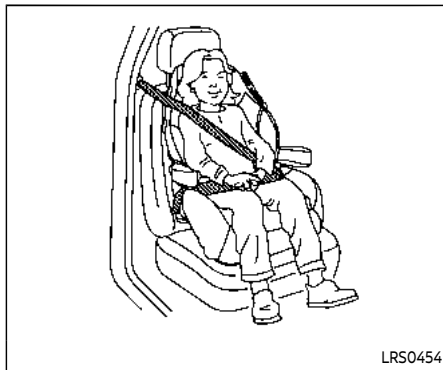
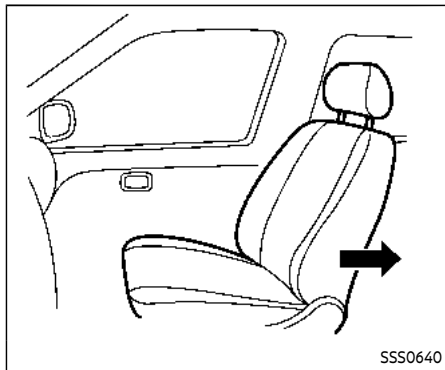

1. **If you must install a booster seat in the front seat, move the seat to the rearmost position.**
2. Position the booster seat on the seat. Only place it in a forward-facing direction. Always follow the booster seat manufacturer's instructions.

3. The booster seat should be positioned on the vehicle seat so that it is stable. If necessary, adjust or remove the head restraint/headrest to obtain the correct booster seat fit. If the head restraint/headrest is removed, store it in a secure place. **Be sure to reinstall the head restraint/headrest when the booster seat is removed.** See "Head restraints/headrests" (P.1-11) for head restraint/headrest adjustment, removal and installation information.
If the head restraint/headrest of the seating position is interfering with the proper booster seat fit, try another seating position or a different booster

seat.

4. Position the lap portion of the seat belt low and snug on the child's hips. Be sure to follow the booster seat manufacturer's instructions for adjusting the seat belt routing.
5. Pull the shoulder belt portion of the seat belt toward the retractor to take up extra slack. Be sure the shoulder belt is positioned across the top, middle portion of the child's shoulder. Be sure to follow the booster seat manufacturer's instructions for adjusting the seat belt routing.
6. Follow the warnings, cautions and instructions for properly fastening a seat belt shown in "Seat belts" (P.1-15).

SUPPLEMENTAL RESTRAINT SYSTEM (SRS)



7. If the booster seat is installed in the front passenger seat, place the ignition switch in the ON position. The front passenger air bag status light  may or may not illuminate depending on the size of the child and the type of booster seat used. See "Front passenger air bag and status light" (P.1-55).

PRECAUTIONS ON SRS

This SRS section contains important information concerning the following systems:

- Driver and front passenger supplemental front-impact air bag (NISSAN Advanced Air Bag System)
- Driver and front passenger supplemental knee air bag
- Front seat-mounted side-impact supplemental air bag
- Rear outboard seat-mounted side-impact supplemental air bag
- Front central seat-mounted side-impact supplemental air bag (if so equipped)
- Roof-mounted curtain side-impact and rollover supplemental air bag
- Seat belt with pretensioner (front and rear outboard seats)

Supplemental front-impact air bag system: The NISSAN Advanced Air Bag System can help cushion the impact force to the head and chest of the driver and front passenger in certain frontal collisions.

Driver and front passenger supplemental knee air bag system: This system can help cushion the impact force to the driver's and front passenger's knees in certain collisions.

Front seat-mounted side-impact supplemental air bag system: This system can help cushion the impact force to the chest and pelvic area of the driver and front passenger in certain side impact collisions. The side air bag is designed to inflate on the side where the vehicle is impacted.

Rear outboard seat-mounted side-impact supplemental air bag system: This system can help cushion the impact force to the chest and pelvic area of the rear outboard seat passengers in certain side-impact collisions. The side air bags are designed to inflate on the side where the vehicle is impacted.

Front central seat-mounted side-impact supplemental air bag (if so equipped): This system can help cushion the impact force to the head area of the driver and front passenger in certain side-impact collisions. The front central side-impact air bag is designed to inflate in the front central area where the vehicle is impacted.

Roof-mounted curtain side-impact and rollover supplemental air bag system: This system can help cushion the impact force to the heads of occupants in front and rear outboard seating positions in certain side impact or rollover collisions. In a side-impact, the curtain air bags are

designed to inflate on the side where the vehicle is impacted. In a rollover, the curtain air bags on both sides are designed to inflate. Under both side-impact and rollover situations, the curtain air bags will remain inflated for a short period of time.

These supplemental restraint systems are designed to **supplement** the crash protection provided by the driver, passenger and rear outboard seat belts and are **not a substitute** for them. Seat belts should always be correctly worn and the occupant seated a suitable distance away from the steering wheel, instrument panel and door finishers. (See "Seat belts" (P.1-15) for instructions and precautions on seat belt usage.)

The supplemental air bags operate only when the ignition switch is in the ON position.

After the ignition is placed in the ON position, the supplemental air bag warning light illuminates. The supplemental air bag warning light will turn off after about 7 seconds if the systems are operational.

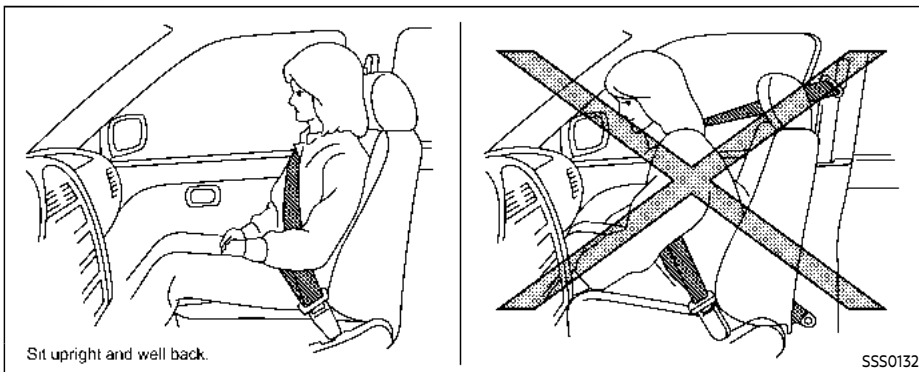
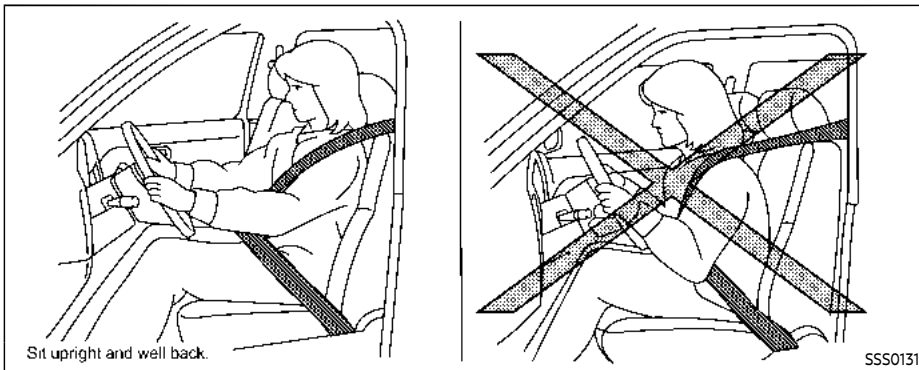



WARNING

- The front air bags ordinarily will not inflate in the event of a side impact, rear impact, rollover, or lower severity frontal collision. Always wear your seat belts to help reduce the risk or severity of injury in various kinds of accidents.
- The front passenger air bag and passenger knee air bag will not inflate if the front passenger air bag status light is lit. See “Front passenger air bag and status light” (P.1-55).
- The seat belts and the front air bags are most effective when you are sitting well back and upright in the seat with both feet on the floor. The front air bags inflate with great force. Even with the NISSAN Advanced Air Bag System, if you are unrestrained, leaning forward, sitting sideways or out of position in any way, you are at greater risk of injury or death in a crash. You may also receive serious or fatal injuries from the front air bag if you are up against it when it inflates. Always sit back

against the seatback and as far away as practical from the steering wheel or instrument panel. Always properly use the seat belts.

- The driver and front passenger seat belt buckles are equipped with sensors that detect if the seat belts are fastened. The Advanced Air Bag System monitors the severity of a collision and seat belt usage then inflates the air bags as needed. Failure to properly wear seat belts can increase the risk or severity of injury in an accident.
- The front passenger seat is equipped with occupant classification sensors (weight sensors) that turn the front passenger air bag and front passenger knee air bag OFF under some conditions. These sensors are only used in this seat. Failure to be properly seated and wearing the seat belt can increase the risk or severity of injury in an accident. See “Front passenger air bag and status light” (P.1-55).
- Keep hands on the outside of the steering wheel. Placing them inside the steering wheel rim could

increase the risk that they are injured if the front air bag inflates.

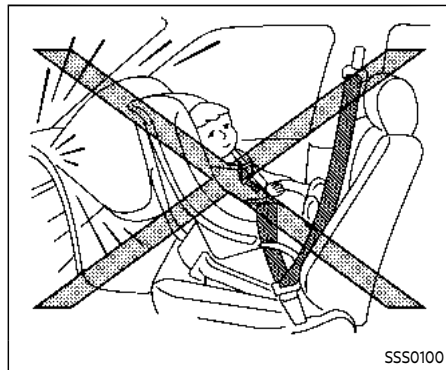
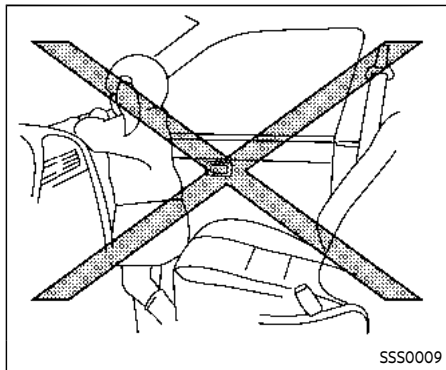
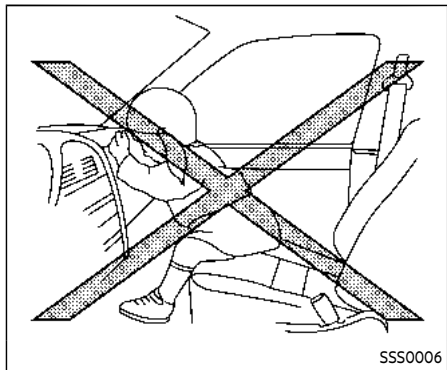
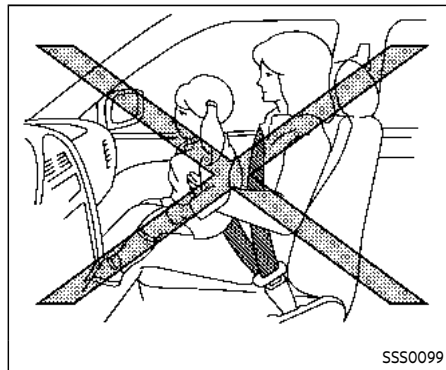
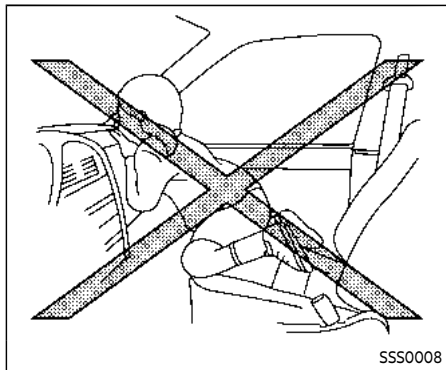
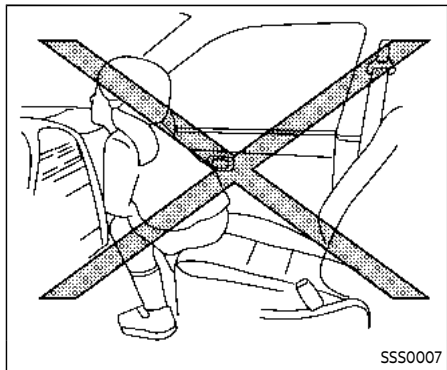

 **WARNING**

- Never let children ride unrestrained or extend their hands or face out of the window. Do not attempt to hold them in your lap or arms. Some examples of dangerous riding positions are shown in the illustrations.
- Children may be severely injured or killed when the front air bags, side air bags or curtain air bags inflate if they are not properly restrained. Pre-teens and children should be properly restrained in the rear seat, if possible.
- Even with the NISSAN Advanced Air Bag System, never install a rear-facing child restraint in the front seat. An inflating front air bag could seriously injure or kill your child. See "Child restraints" (P.1-25) for details.

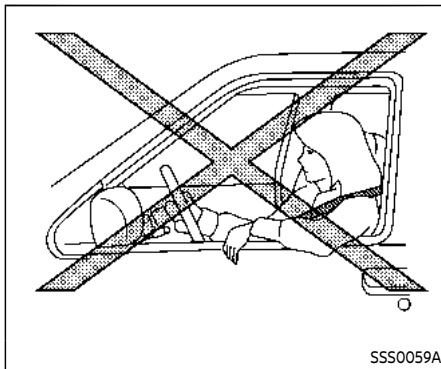

Do not lean against doors or windows.

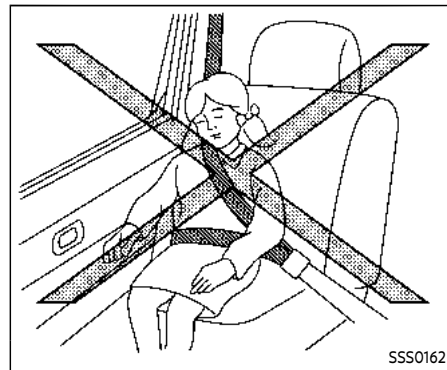
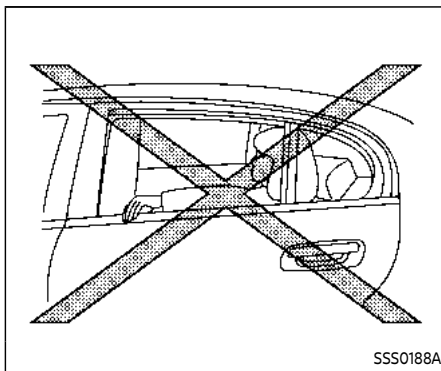
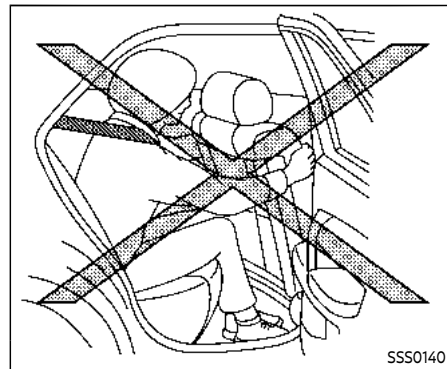

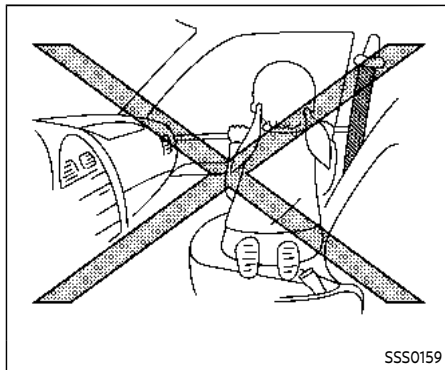

WARNING

Front, front central and rear outboard seat-mounted side-impact supplemental air bags and roof-mounted curtain side-impact and rollover supplemental air bags:

- The side air bags ordinarily will not inflate in the event of a frontal impact, rear impact, rollover or lower severity side collision. Always wear your seat belts to help reduce the risk or severity of injury in various kinds of accidents.

- The curtain air bags ordinarily will not inflate in the event of a front impact, rear impact, or lower severity side collision. Always wear your seat belts to help reduce the risk or severity of injury in various kinds of accidents.
- The seat belts, the side air bags and curtain air bags are most effective when you are sitting well back and upright in the seat. The side air bags and curtain air bags inflate with great force. Do not allow anyone to place their hand, leg or face near the side air bags on the side of the seatback of the front and rear seat or near the side roof rails. Do not allow anyone sitting in the front seats or rear outboard seats to extend their hand out of the window or lean against the door. Some examples of dangerous riding positions are shown in the previous illustrations.
- When sitting in the rear seat, do not hold onto the seatback of the front seat. If the side air bags inflate, you may be seriously injured. Be especially careful with children, who should always be

properly restrained. Some examples of dangerous riding positions are shown in the illustrations.

- Do not use seat covers on the front and rear seatbacks. They may interfere with side air bag inflation.

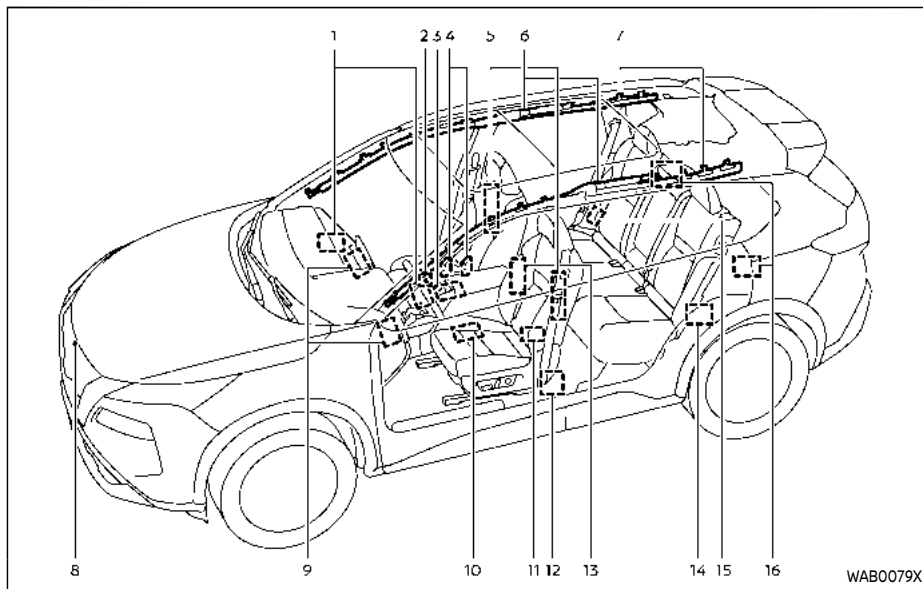

1. Supplemental front-impact air bag modules (NISSAN Advanced Air Bags)
2. Occupant classification system control unit
3. Air bag Control Unit (ACU)
4. Occupant classification sensors (weight sensors)
5. Front seat-mounted side-impact supple-

mental air bag modules

6. Roof-mounted curtain side-impact and rollover supplemental air bag inflators
7. Roof-mounted curtain side-impact and rollover supplemental air bag modules
8. Crash zone sensor
9. Driver and front passenger supplemental knee air bags

10. Front door pressure sensors (driver's side shown; front passenger side similar)
11. Lap outer pretensioners (front seats)
12. Seat belt with pretensioners (front seats)
13. Front central seat-mounted side-impact supplemental air bag (if so equipped)
14. Satellite sensors (driver's side shown; front passenger side similar)
15. Rear outboard seat-mounted side-impact supplemental air bag modules
16. Seat belt with pretensioners (rear outboard seats)

NISSAN ADVANCED AIR BAG SYSTEM (front seats)



WARNING

To ensure proper operation of the passenger's Advanced Air Bag system, please observe the following items.

- Do not allow a passenger in the rear seat to push or pull on the seatback pocket.
- Do not place heavy loads heavier than 9.1 lbs (4 kg) on the seatback, head restraint or in the seatback pocket.
- Make sure nothing is pressing against the rear of the seatback,

such as a child restraint installed in the rear seat or an object stored on the floor.

- Make sure that there is no object placed under the front passenger seat.
- Make sure that there is no object placed between the seat cushion and center console or between the seat cushion and the door.
- Be sure that the front passenger seat does not contact the rear seat, instrument panel, etc., or the head restraint does not contact the roof.
- Do not position the front passenger seat so it contacts the rear seat. If the front seat does contact the rear seat, the air bag system may determine a sensor malfunction has occurred and the front passenger air bag status light may illuminate and the supplemental air bag warning light may flash.
- If a forward facing child restraint is installed in the front passenger seat, do not position the front passenger seat so the child restraint contacts the instrument panel. If the child restraint does

contact the instrument panel, the system may determine the seat is occupied and the passenger air bag and front passenger knee air bag may deploy in a collision. Also the front passenger air bag status light may not illuminate. See "Child restraints" (P.1-25) for information about installing and using child restraints.

- Confirm the operating condition with the front passenger air bag status light.
- If you notice that the front passenger air bag status light is not operating as described in this section, it is recommended you visit a NISSAN dealer to check the passenger seat Advanced Air Bag System.
- Until you have confirmed with your dealer that your passenger seat Advanced Air Bag is working properly, position the occupants in the rear seating positions.

This vehicle is equipped with the NISSAN Advanced Air Bag System for the driver and front passenger seats. This system is designed to meet certification requirements under U.S. regulations. It is also permitted in Canada. **All of the informa-**

tion, cautions and warnings in this manual apply and must be followed.

The driver supplemental front-impact air bag is located in the center of the steering wheel. The passenger supplemental front-impact air bag is mounted in the instrument panel above the glove box. The front air bags are designed to inflate in higher severity frontal collisions, although they may inflate if the forces in another type of collision are similar to those of a higher severity frontal impact. They may not inflate in certain frontal collisions. Vehicle damage (or lack of it) is not always an indication of proper front air bag operation.

The NISSAN Advanced Air Bag System has dual stage air bag inflators. The system monitors information from the Air bag Control Unit (ACU), seat belt buckle sensors and the occupant classification sensors (weight sensors). Inflator operation is based on the severity of a collision and seat belt usage for the driver. For the front passenger, the occupant classification sensors are also monitored. Based on information from the sensors, only one front air bag may inflate in a crash, depending on the crash severity and whether the front occupants are belted or unbelted. Additionally, the front passenger air bag and front passenger knee

air bag may be automatically turned OFF under some conditions, depending on the information provided by the occupant classification sensors. If the front passenger air bag and front passenger knee air bag are OFF, the front passenger air bag status light will be illuminated. (See "Front passenger air bag and status light" (P.1-55) for further details.) One front air bag inflating does not indicate improper performance of the system.

If you have any questions about your air bag system, it is recommended you visit a NISSAN dealer to obtain information about the system. If you are considering modification of your vehicle due to a disability, you may also contact NISSAN. Contact information is contained in the front of this Owner's Manual.

When a front air bag inflates, a fairly loud noise may be heard, followed by release of smoke. This smoke is not harmful and does not indicate a fire. Care should be taken not to inhale it, as it may cause irritation and choking. Those with a history of a breathing condition should get fresh air promptly.

Front air bags, along with the use of seat belts, help to cushion the impact force on the head and chest of the front occupants. They can help save lives and reduce serious injuries. However, an in-

flating front air bag may cause facial abrasions or other injuries. Front air bags, other than the driver's and front passenger's knee air bags, do not provide restraint to the lower body.

Even with NISSAN Advanced Air Bags, seat belts should be correctly worn and the driver and passenger seated upright as far as practical away from the steering wheel or instrument panel. The front air bags inflate quickly in order to help protect the front occupants. Because of this, the force of the front air bag inflating can increase the risk of injury if the occupant is too close to, or is against, the air bag module during inflation.

The front air bags deflate quickly after a collision.

The front air bags operate only when the ignition switch is in the ON position.

After the ignition is placed in the ON position, the supplemental air bag warning light illuminates. The supplemental air bag warning light will turn off after about 7 seconds if the system is operational.



Front passenger air bag status light

Front passenger air bag and status light





WARNING

The front passenger air bag and front passenger knee air bag are designed to automatically turn OFF under some conditions. Read this section carefully to learn how it operates. Proper use of the seat, seat belt and child restraints is necessary for most effective protection. Failure to follow all instructions in this manual concern-

ing the use of seats, seat belts and child restraints can increase the risk or severity of injury in an accident.

Status light:

The front passenger seat is equipped with occupant classification sensors (weight sensors) that turn the front passenger air bag and front passenger knee air bag on or off depending on the weight applied to the front passenger seat. The status of the front passenger air bag and front passenger knee air bag (ON or OFF) is indicated by the front passenger air bag status light  which is located on the map light. After the ignition switch is placed in the ON position, the front passenger air bag status light illuminates for about 7 seconds and then turns off or remains illuminated depending on the front passenger seat occupied status. The light operates as follows:

CONDITION	DESCRIPTION	PASSENGER AIR BAG INDICATOR LIGHT ()	FRONT PASSENGER AIR BAG AND FRONT PASSENGER KNEE AIR BAG STATUS
Empty	Empty front passenger seat	ON (illuminated)	INHIBITED
Nobody/Somebody	Bag or Child or Child Restraint or Small Adult in front passenger seat	ON (illuminated)	INHIBITED
Adult	Adult in the front passenger seat	OFF (dark)	ACTIVATED

In addition to the above, certain objects placed on the front passenger seat may also cause the light to operate as described above depending on their weight. For additional information related to the normal operation and troubleshooting of this occupant classification sensor system, please refer to “Normal operation” (P.1-59) and “Troubleshooting” (P.1-60) in this section.

Front passenger air bag:

The front passenger air bag is designed to automatically turn OFF when the vehicle is operated under some conditions as described below as permitted by U.S. regulations. If the front passenger air bag is OFF, it will not inflate in a crash. The driver air bag and other air bags in your vehicle are not part of this system.

The purpose of the regulation is to help reduce the risk of injury or death from an inflating air bag to certain front passenger seat occupants, such as children, by requiring the air bag to be automatically turned OFF. Certain sensors are used to meet the requirements.

The occupant classification sensor in this vehicle is a weight sensor. It is designed to detect an occupant and objects on the seat by weight. For example, if a child is in the front passenger seat, the Advanced

Air Bag System is designed to turn the passenger air bag OFF in accordance with the regulations. Also, if a child restraint of the type specified in the regulations is on the seat, its weight and the child's weight can be detected and cause the air bag to turn OFF.

Front passenger seat adult occupants who are properly seated and using the seat belt as outlined in this manual should not cause the passenger air bag and front passenger knee air bag to be automatically turned OFF. For small adults it may be turned OFF, however, if the occupant takes his/her weight off the seat cushion (for example, by not sitting upright, by sitting on an edge of the seat, or by otherwise being out of position), this could cause the sensors to turn the air bag OFF. Always be sure to be seated and wearing the seat belt properly for the most effective protection by the seat belt and supplemental air bag.

NISSAN recommends that pre-teens and children be properly restrained in a rear seat. NISSAN also recommends that appropriate child restraints and booster seats be properly installed in a rear seat. If this is not possible, the occupant classification sensors are designed to operate as described above to turn the front passenger air bag and front pas-

senger knee air bag OFF for specified child restraints as required by the regulations. Failing to properly secure child restraints and to use the Automatic Locking Retractor (ALR) mode (child restraint mode) may allow the restraint to tip or move in an accident or sudden stop. This can also result in the passenger air bag and front passenger knee air bag inflating in a crash instead of being OFF. (See “Child restraints” (P.1-25) for proper use and installation.)

If the front passenger seat is not occupied, the passenger air bag and front passenger knee air bag are designed not to inflate in a crash. However, heavy objects placed on the seat could result in air bag inflation, because of the object's weight detected by the occupant classification sensors. Other conditions could also result in air bag inflation, such as if a child is standing on the seat, or if two children are on the seat, contrary to the instructions in this manual. Always be sure that you and all vehicle occupants are seated and restrained properly.

Using the front passenger air bag status light, you can monitor when the front passenger air bag and front passenger knee air bag are automatically turned OFF.

If an adult occupant is in the seat but the

front passenger air bag status light is illuminated (indicating that the front passenger air bag and front passenger knee air bag are OFF), it could be that the person is a small adult, or is not sitting on the seat properly.

If a child restraint must be used in the front seat, the front passenger air bag status light may or may not be illuminated, depending on the size of the child and the type of child restraint being used. If the front passenger air bag status light is not illuminated (indicating that the air bag might inflate in a crash), it could be that the child restraint or seat belt is not being used properly. Make sure that the child restraint is installed properly, the seat belt is used properly and the occupant is positioned properly. If the front passenger air bag status light is not illuminated, reposition the occupant or child restraint in a rear seat.

If the front passenger air bag status light will not illuminate even though you believe that the child restraint, the seat belts and the occupant are properly positioned, it is recommended that you take your vehicle to a NISSAN dealer. A NISSAN dealer can check the system status by using a special tool. However, until you have confirmed with your dealer that your air bag is working properly, reposition

the occupant or child restraint in a rear seat.

The NISSAN Advanced Air Bag System and front passenger air bag status light will take a few seconds to register a change in the passenger seat status. This is normal system operation and does not indicate a malfunction.

If a malfunction occurs in the front passenger air bag system, the supplemental air bag warning light , located in the meters and gauges area, will illuminate (blinking or steadily lit). Have the system checked. It is recommended you visit a NISSAN dealer for this service.

Normal operation:

In order for the occupant classification sensor system to classify the front passenger based on weight, please follow the precautions and steps outlined below:

Precautions:

- Make sure that there are no objects weighing over 9.1 lbs (4 kg) hanging on the seat or placed in the seatback pocket.
- Make sure that a child restraint or other object is not pressing against the rear of the seatback.
- Make sure that a rear passenger is not pushing or pulling on the back of the front passenger seat.

- Make sure that the front passenger seat or seatback is not forced back against an object on the seat or floor behind it.
- Make sure that there is no object placed under the front passenger seat.
- Make sure that the front passenger seat head restraint does not contact the roof when adjusting the front passenger seat.

Steps:

1. Adjust the seat as outlined. (See "Seats" (P.1-3).) Sit upright, leaning against the seatback, and centered on the seat cushion with your feet comfortably extended to the floor.
2. Make sure there are no objects on your lap.
3. Fasten the seat belt as outlined. (See "Seat belts" (P.1-15).) Front passenger seat belt buckle status is monitored by the occupant classification system, and is used as an input to determine occupancy status. So, it is highly recommended that the front passenger fasten their seat belt.
4. Remain in this position for 30 seconds allowing the system to classify the front passenger before the vehicle is put into motion.

5. Ensure proper classification by checking the front passenger air bag status light.

NOTE:

This vehicle's occupant classification sensor system generally keeps the classification locked during driving, so it is important that you confirm that the front passenger is properly classified prior to driving. However, the occupant classification sensor system may recalculate the weight of the occupant under some conditions (both while driving and when stopped), so the front passenger seat occupant should continue to remain seated as outlined above.

Troubleshooting:

If you think the front passenger air bag status light is incorrect:

1. If the light is ON with an adult occupying the front passenger seat:
 - Occupant is a small adult — the front passenger air bag status light is functioning as intended. The front passenger air bag and front passenger knee air bag are suppressed.

However, if the occupant is not a small adult, then this may be due to the following conditions that may be interfering with the weight sensors:

- Occupant is not sitting upright, leaning against the seatback, and centered on the seat cushion with his/her feet comfortably extended to the floor.
- A child restraint or other object pressing against the rear of the seatback.
- A rear passenger pushing or pulling on the back of the front passenger seat.
- Forcing the front seat or seatback against an object on the seat or floor behind it.
- An object placed under the front passenger seat.
- An object placed between the seat cushion and center console or between the seat cushion and the door.

If the vehicle is moving, please come to a stop when it is safe to do so. Check and correct any of the above conditions. Restart the vehicle and wait 1 minute.

NOTE:

A system check will be performed during which the front passenger air bag status light will remain lit for about 7 seconds initially.

If the light is still ON after this, the person should be advised not to ride in the front passenger seat and the vehicle should be checked as soon as possible. It is recom-

mended you visit a NISSAN dealer for this service.

2. If the light is OFF with a small adult, child or child restraint occupying the front passenger seat.

This may be due to the following conditions that may be interfering with the weight sensors:

- Small adult or child is not sitting upright, leaning against the seatback, and centered on the seat cushion with his/her feet comfortably extended to the floor.
- The child restraint is not properly installed, as outlined. (See "Child restraints" (P.1-25).)
- An object weighing over 9.1 lbs (4 kg) hanging on the seat or placed in the seatback pocket.
- A child restraint or other object pressing against the rear of the seatback.
- A rear passenger pushing or pulling on the back of the front passenger seat.
- Forcing the front seat or seatback against an object on the seat or floor behind it.
- An object placed under the front passenger seat.
- An object placed between the seat cushion and center console.

- The front passenger seat head restraint contacting the roof.

If the vehicle is moving, please come to a stop when it is safe to do so. Check and correct any of the above conditions. Restart the vehicle and wait 1 minute.

NOTE:

A system check will be performed during which the front passenger air bag status light will remain lit for about 7 seconds initially.

If the light is still OFF after this, the small adult, child or child restraint should be repositioned in the rear seat and it is recommended that the vehicle should be checked by a NISSAN dealer as soon as possible.

3. If the light is OFF with no front passenger and no objects on the front passenger seat, the vehicle should be checked as soon as possible. It is recommended you visit a NISSAN dealer for this service.

Other supplemental front-impact air bag precautions



WARNING

- Do not place any objects on the steering wheel pad or on the instrument panel. Also, do not

place any objects between any occupant and the steering wheel or instrument panel. Such objects may become dangerous projectiles and cause injury if the front air bags inflate.

- Do not place objects with sharp edges on the seat. Also, do not place heavy objects on the seat that will leave permanent impressions in the seat. Such objects can damage the seat or occupant classification sensors (weight sensors). This can affect the operation of the air bag system and result in serious personal injury.
- Do not use water or acidic cleaners (hot steam cleaners) on the seat. This can damage the seat or occupant classification sensors. This can also affect the operation of the air bag system and result in serious personal injury.
- Immediately after inflation, several front air bag system components will be hot. Do not touch them; you may severely burn yourself.
- No unauthorized changes should be made to any components or wiring of the supplemental air

bag system. This is to prevent accidental inflation of the supplemental air bag or damage to the supplemental air bag system.

- Do not make unauthorized changes to your vehicle's electrical system, suspension system or front end structure. This could affect proper operation of the front air bag system.
- Tampering with the front air bag system may result in serious personal injury. Tampering includes changes to the steering wheel and the instrument panel assembly by placing material over the steering wheel pad and above the instrument panel or by installing additional trim material around the air bag system.
- Removing or modifying the front passenger seat may affect the function of the air bag system and result in serious personal injury.
- Modifying or tampering with the front passenger seat may result in serious personal injury. For example, do not change the front seats by placing material on the seat cushion or by installing ad-

ditional trim material, such as seat covers, on the seat that is not specifically designed to assure proper air bag operation. Additionally, do not stow any objects under the front passenger seat or the seat cushion and seatback. Such objects may interfere with the proper operation of the occupant classification sensors.

- No unauthorized changes should be made to any components or wiring of the seat belt system. This may affect the front air bag system. Tampering with the seat belt system may result in serious personal injury.
- It is recommended you visit a NISSAN dealer for work on and around the front air bag. It is also recommended you visit a NISSAN dealer for installation of electrical equipment. The Supplemental Restraint System (SRS) wiring harnesses* should not be modified or disconnected. Unauthorized electrical test equipment and probing devices should not be used on the air bag system.

- A cracked windshield should be replaced immediately by a qualified repair facility. A cracked windshield could affect the function of the supplemental air bag system.

*The SRS wiring harness connectors are yellow and orange for easy identification.

When selling your vehicle, we request that you inform the buyer about the front air bag system and guide the buyer to the appropriate sections in this Owner's Manual.

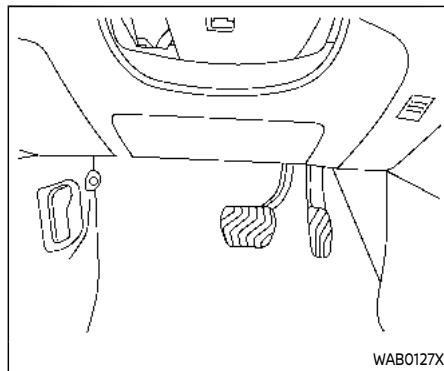

Driver's side

DRIVER AND FRONT PASSENGER SUPPLEMENTAL KNEE AIR BAG

The knee air bag is located in the knee bolster, on the driver's and front passenger's sides. **All of the information, cautions and warnings in this manual apply and must be followed.** The knee air bag is designed to inflate in higher severity frontal collisions, although it may inflate if the forces in another type of collision are similar to those of a higher severity frontal impact. It may not inflate in certain collisions.

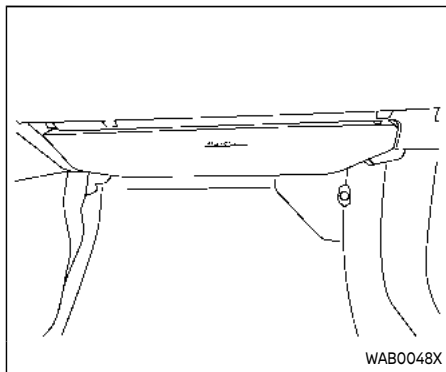

Front passenger's side

Vehicle damage (or lack of it) is not always an indication of proper knee air bag operation.

When the knee air bag inflates, a fairly loud noise may be heard, followed by release of smoke. This smoke is not harmful and does not indicate a fire. Care should be taken not to inhale it, as it may cause irritation and choking. Those with a history of a breathing condition should get fresh air promptly.

The knee air bag helps to cushion the impact force on the knees of the driver and front passenger. It can help reduce serious injuries. However, an inflating knee air bag may cause abrasions or

other injuries. The knee air bag provides restraint to the lower body.

The knee air bag inflates quickly in order to help protect the occupants. Because of this, the force of the knee air bag inflating can increase the risk of injury if the occupant is too close to, or is against, this air bag module during inflation. The knee air bag will deflate quickly after the collision is over OR the knee air bag will remain inflated for a short time.

The knee air bag operates only when the ignition switch is placed in the ON position.

After placing the ignition switch in the ON position, the supplemental air bag warning light illuminates. The supplemental air bag warning light will turn off after about 7 seconds if the system is operational.



WARNING

- **Do not place any objects between the knee bolster and the driver's or front passenger's seat. Such objects may become dangerous projectiles and cause injury if a knee air bag inflates.**

- **Right after inflation, the knee air bag system components will be hot. Do not touch them; you may severely burn yourself.**
- **No unauthorized changes should be made to any components or wiring of the knee air bag system. This is to prevent damage to or accidental inflation of the knee air bag system.**
- **Do not make unauthorized changes to your vehicle's electrical system or suspension system. This could affect proper operation of the knee air bag system.**
- **Tampering with the knee air bag system may result in serious personal injury. For example, do not change the driver or front passenger knee bolster or install additional trim material around the knee air bag.**
- **It is recommended that you visit a NISSAN dealer for work on and around the knee air bag. It is also recommended that you visit a NISSAN dealer for installation of electrical equipment. The SRS wiring harnesses* should not be modified or disconnected. Unauthorized electrical test equip-**

ment and probing devices should not be used on the knee air bag system.

***The SRS wiring harness or connectors are yellow or orange for easy identification.**

When selling your vehicle, we request that you inform the buyer about the knee air bag system and guide the buyer to the appropriate sections in this manual.

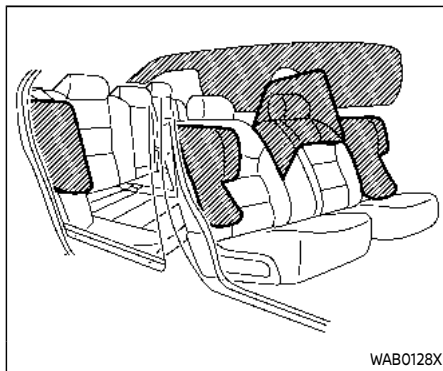

FRONT, FRONT CENTRAL*, REAR OUTBOARD SEAT-MOUNTED SIDE-IMPACT SUPPLEMENTAL AIR BAG AND ROOF-MOUNTED CURTAIN SIDE-IMPACT AND ROLLOVER SUPPLEMENTAL AIR BAG SYSTEMS

*: if so equipped

The side air bags are located in the outside of the seatback of the front and rear seats. The front central side air bag (if so equipped) is located in the inside of the seatback of the driver's seat. The curtain air bags are located in the side roof rails.

All of the information, cautions and warnings in this manual apply and must

be followed. The side air bags and curtain air bags are designed to inflate in higher severity side collisions, although they may inflate if the forces in another type of collision are similar to those of a higher severity side impact. They are designed to inflate on the side where the vehicle is impacted. They may not inflate in certain side collisions.

Curtain air bags are also designed to inflate in certain types of rollover collisions or near rollovers. As a result, certain vehicle movements (for example, during severe off-roading) may cause the curtain air bags to inflate.

Vehicle damage (or lack of it) is not always an indication of proper side air bag and curtain air bag operation.

When the side air bags and curtain air bags inflate, a fairly loud noise may be heard, followed by release of smoke. This smoke is not harmful and does not indicate a fire. Care should be taken not to inhale it, as it may cause irritation and choking. Those with a history of a breathing condition should get fresh air promptly.

Side air bags, along with the use of seat belts, help to cushion the impact force on the chest and pelvic area of the front and rear outboard occupants. Front central side air bag, along with the use of seat

belts, helps to cushion the impact force on the head area of the front occupants. Curtain air bags help to cushion the impact force to the head and chest area of occupants in the front and rear outboard seating positions. They can help save lives and reduce serious injuries. However, an inflating side air bag or curtain air bag may cause abrasions or other injuries. Side air bags and curtain air bags do not provide restraint to the lower body.

The seat belts should be correctly worn and the driver, front passenger and rear outboard occupants seated upright as far as practical away from the side air bags. Rear seat passengers should be seated as far away as practical from the door finishers and side roof rails. The side air bags and curtain air bags inflate quickly in order to help protect the occupants. Because of this, the force of the side air bags and curtain air bags inflating can increase the risk of injury if the occupant is too close to, or is against, these air bag modules during inflation. The side air bags will deflate quickly after the collision is over. The front central side air bag and curtain air bags will remain inflated for a short time.

The side air bags and curtain air bags operate only when the ignition switch is

in the ON position.

After placing the ignition switch in the ON position, the supplemental air bag warning light illuminates. The supplemental air bag warning light will turn off after about 7 seconds if the systems are operational.



WARNING

- **Do not place any objects near the seatback of the front and rear seats. Also, do not place any objects (an umbrella, bag, etc.) between the front and rear door finisher, the center console, and the front and rear seats. Such objects may become dangerous projectiles and cause injury if a side air bag inflates.**
- **Right after inflation, several side air bag and curtain air bag system components will be hot. Do not touch them; you may severely burn yourself.**
- **No unauthorized changes should be made to any components or wiring of the side air bag and curtain air bag systems. This is to prevent damage to or accidental inflation of the side air bag and**

curtain air bag systems.

- **Do not make unauthorized changes to your vehicle's electrical system, suspension system or side panel. This could affect proper operation of the side air bag and curtain air bag systems.**
- **Tampering with the side air bag system may result in serious personal injury. For example, do not change the front and rear seats by placing material near the seatbacks or by installing additional trim material, such as seat covers, around the side air bag.**
- **Removing or modifying the front and rear passenger seat may affect the function of the air bag system and result in serious personal injury.**
- **It is recommended you visit a NISSAN dealer for work on and around the side air bag and curtain air bag. It is also recommended you visit a NISSAN dealer for installation of electrical equipment. The Supplemental Restraint System (SRS) wiring harnesses* should not be modified or disconnected. Unauthorized electrical test equipment**

and probing devices should not be used on the side air bag or curtain air bag systems.

***The SRS wiring harness connectors are yellow and orange for easy identification.**

When selling your vehicle, we request that you inform the buyer about the side air bag and curtain air bag systems and guide the buyer to the appropriate sections in this Owner's Manual.

SEAT BELTS WITH PRETENSIONERS
(front and rear outboard seats)



WARNING

- **The pretensioners cannot be re-used after activation. They must be replaced together with the retractor and buckle as a unit.**
- **If the vehicle becomes involved in a collision but a pretensioner is not activated, be sure to have the pretensioner system checked and, if necessary, repaired. It is recommended you visit a NISSAN dealer for this service.**
- **No unauthorized changes should be made to any components or**

wiring of the pretensioner system. This is to prevent damage to or accidental activation of the pretensioners. Tampering with the pretensioner system may result in serious personal injury.

- **It is recommended you visit a NISSAN dealer for work on and around the pretensioner system. It is also recommended you visit a NISSAN dealer for installation of electrical equipment. Unauthorized electrical test equipment and probing devices should not be used on the pretensioner system.**
- **If you need to dispose of a pretensioner or scrap the vehicle, it is recommended you visit a NISSAN dealer for this service. Correct pretensioner disposal procedures are set forth in the appropriate NISSAN Service Manual. Incorrect disposal procedures could cause personal injury.**

The pretensioner system may activate with the supplemental air bag system in certain types of collisions. Working with the seat belt retractor, it helps tighten the seat belt when the vehicle becomes involved in certain types of collisions,

helping to restrain front and rear outboard seat occupants.

The pretensioner is encased with the seat belt retractor. These seat belts are used the same way as conventional seat belts.

When a pretensioner activates, smoke is released and a loud noise may be heard. The smoke is not harmful and does not indicate a fire. Care should be taken not to inhale it, as it may cause irritation and choking. Those with a history of a breathing condition should get fresh air promptly.

After pretensioner activation, load limiters allow the seat belt to release webbing (if necessary) to reduce forces against the chest.

The supplemental air bag warning light  is used to indicate malfunctions in the pretensioner system. See "Supplemental air bag warning light" (P.1-67). If the operation of the supplemental air bag warning light indicates there is a malfunction, have the system checked. It is recommended you visit a NISSAN dealer for this service.

When selling your vehicle, we request that you inform the buyer about the pretensioner system and guide the buyer to the appropriate sections in this Owner's Manual.

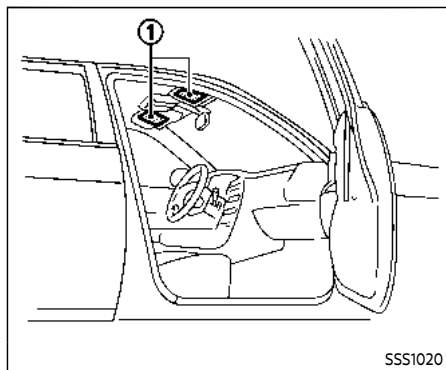

SUPPLEMENTAL AIR BAG WARNING LABELS

Warning labels about the supplemental front-impact air bag system are placed in the vehicle as shown in the illustration.

① SRS air bag

The warning labels are located on the surface of the sun visors.



WARNING

Do not use a rear-facing child restraint on a seat protected by an air bag in front of it. If the air bag

deploys, it may cause serious injury or death.



SUPPLEMENTAL AIR BAG WARNING LIGHT

The supplemental air bag warning light, displaying  in the instrument panel, monitors the circuits for the air bag systems, pretensioners and all related wiring.

When the ignition switch is in the ON position, the supplemental air bag warning light illuminates for about 7 seconds and then turns off. This means the system is operational.

If any of the following conditions occur, the air bag and/or pretensioner systems need servicing:

- The supplemental air bag warning light remains on after approximately 7 seconds.
- The supplemental air bag warning light flashes intermittently.
- The supplemental air bag warning light does not come on at all.

Under these conditions, the air bag and/or pretensioner systems may not operate properly. They must be checked and repaired. It is recommended you visit a NISSAN dealer for this service.



WARNING

If the supplemental air bag warning light is on, it could mean that the front air bag, knee air bag, side air bag, curtain air bag and/or pretensioner systems will not operate in an accident. To help avoid injury to yourself or others, have your vehicle checked as soon as possible. It is recommended you visit a NISSAN dealer for this service.

REPAIR AND REPLACEMENT PROCEDURE

The front air bags, knee air bags, side air bags, curtain air bags and pretensioners are designed to activate on a one-time-only basis. As a reminder, unless it is damaged, the supplemental air bag warning light will remain illuminated after inflation has occurred. These systems should be repaired and/or replaced as soon as possible. It is recommended you visit a NISSAN dealer for this service.

When maintenance work is required on the vehicle, the front air bags, knee air bags, side air bags, curtain air bags and pretensioners and related parts should be pointed out to the person performing the maintenance. The ignition switch should always be in the OFF position when working under the hood or inside the vehicle.



WARNING

- **Once a front air bag, knee air bag, side air bag or curtain air bag has inflated, the air bag module will not function again and must be replaced. Additionally, the activated pretensioners must also be replaced. The air bag module**

and pretensioner should be replaced. It is recommended you visit a NISSAN dealer for this service. However, the air bag modules and pretensioner system cannot be repaired.

- **The front air bag, knee air bag, side air bag and curtain air bag systems, and pretensioner system should be inspected if there is any damage to the front end or side portion of the vehicle. It is recommended you visit a NISSAN dealer for this service.**
- **If you need to dispose of a supplemental air bag or pretensioner or scrap the vehicle, it is recommended you visit a NISSAN dealer. Correct supplemental air bag and pretensioner system disposal procedures are set forth in the appropriate NISSAN Service Manual. Incorrect disposal procedures could cause personal injury.**
- **If there is an impact to your vehicle from any direction, your Occupant Classification Sensor (OCS) should be checked to verify it is still functioning correctly. It is recommended that you visit a NISSAN dealer for this service. The OCS should be checked even**

if no air bags deploy as a result of the impact. Failure to verify proper OCS function may result in an improper air bag deployment resulting in injury or death.

MEMO

2 Instruments and controls

Cockpit	2-3	Shortcut Menu	2-23
Instrument panel	2-4	Startup display	2-24
Meters and gauges	2-5	Settings	2-24
Models with analog meter and color display	2-5	Vehicle information display warnings and indicators	2-35
Models with full-screen display	2-6	Trip computer	2-47
Speedometer and odometer	2-8	Clock and outside air temperature	2-49
Tachometer	2-9	Head Up Display (HUD) (if so equipped)	2-50
Engine coolant temperature gauge	2-9	How to use the HUD	2-51
Fuel gauge	2-10	Driver Assistance/Navigation/Traffic Sign/Audio/TEL/SMS linking	2-52
Instrument brightness control	2-11	Security systems	2-53
Continuously Variable Transmission (CVT) position indicator	2-11	Vehicle Security System (if so equipped)	2-53
ECO Drive Report	2-11	NISSAN Vehicle Immobilizer System	2-54
Variable Compression Turbo (if so equipped)	2-12	Wiper and washer switch	2-55
Warning lights, indicator lights and audible reminders	2-13	Windshield wiper and washer operation	2-55
Checking lights	2-14	Rear window wiper and washer operation	2-56
Warning/indicator lights (red)	2-14	Rear window and outside mirror (if so equipped) defroster switch	2-57
Warning/indicator lights (yellow)	2-17	Headlight and turn signal switch	2-58
Warning/indicator lights (other)	2-21	Headlight switch	2-58
Audible reminders	2-22	Turn signal switch	2-64
Vehicle information display	2-22	Fog light switch (if so equipped)	2-65
How to use the vehicle information display	2-23	Horn	2-65
		Heated steering wheel (if so equipped)	2-66

Heated seats (if so equipped)	2-66	Lower console tray	2-79
Operation with switch	2-67	Sunglasses holder	2-79
Steering Assist switch (models with ProPILOT Assist)	2-67	Card holder	2-80
Rear Door Alert	2-68	Coat hooks (if so equipped)	2-80
Power outlets	2-69	Cargo cover (if so equipped)	2-81
USB (Universal Serial Bus) charging connector (if so equipped)	2-70	Luggage hooks	2-81
Wireless charger (if so equipped)	2-70	Roof rack (if so equipped)	2-82
Emergency Call (SOS) button (if so equipped)	2-73	Windows	2-83
Emergency support	2-73	Power windows	2-83
Storage	2-74	Moonroof (if so equipped)	2-86
Cup holders	2-74	Automatic moonroof and sunshade	2-86
Soft bottle holders	2-75	Interior lights	2-88
Single luggage board (if so equipped)	2-76	Interior light switch	2-89
Adjustable luggage floor (if so equipped)	2-76	Map lights	2-89
Glove box	2-78	Room lights (if so equipped)	2-89
Console box	2-79	Rear personal lights (if so equipped)	2-90
		Vanity mirror light	2-90
		Cargo light	2-90

COCKPIT

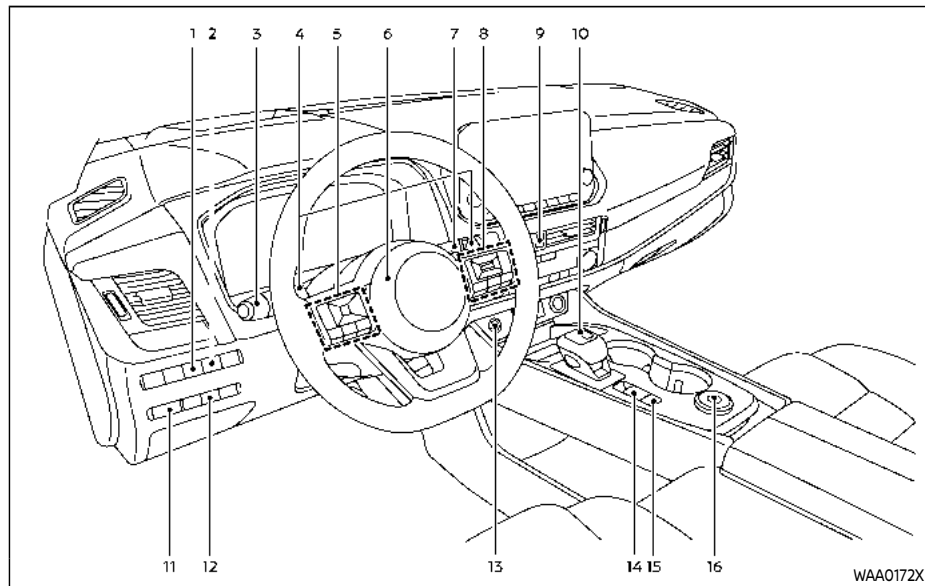

- | | |
|----------------------------------------------------------|-------------------------------------------------|
| 1. Steering Assist switch* (models with ProPILOT Assist) | – Audio control** |
| 2. Head Up Display (HUD) switch* | – Vehicle information display control |
| 3. Headlight and turn signal switch/Fog light switch* | 6. Steering wheel |
| 4. Paddle shifters | – Horn |
| 5. Steering-wheel-mounted controls (left side) | 7. Wiper and washer switch |
| | 8. Steering-wheel-mounted controls (right side) |

- Cruise control switches*
 - ProPILOT Assist switch*
 - Bluetooth® Hands-Free Phone System switches**
 - Voice Recognition system switch**
 - Siri® Eyes Free**
9. Hazard indicator flasher switch
10. Shift lever
- Continuously Variable Transmission (CVT)
11. Instrument brightness control
12. Power liftgate switch*
13. Push-button ignition switch
14. Parking brake switch
15. Automatic brake hold switch
16. Drive Mode Selector***
- *: if so equipped
- ** : See the separate NissanConnect® Owner's Manual (if so equipped).
- ***: The Drive Mode Selector illustrated is for the AWD model. On the 2WD model, the shape and location differ.

INSTRUMENT PANEL

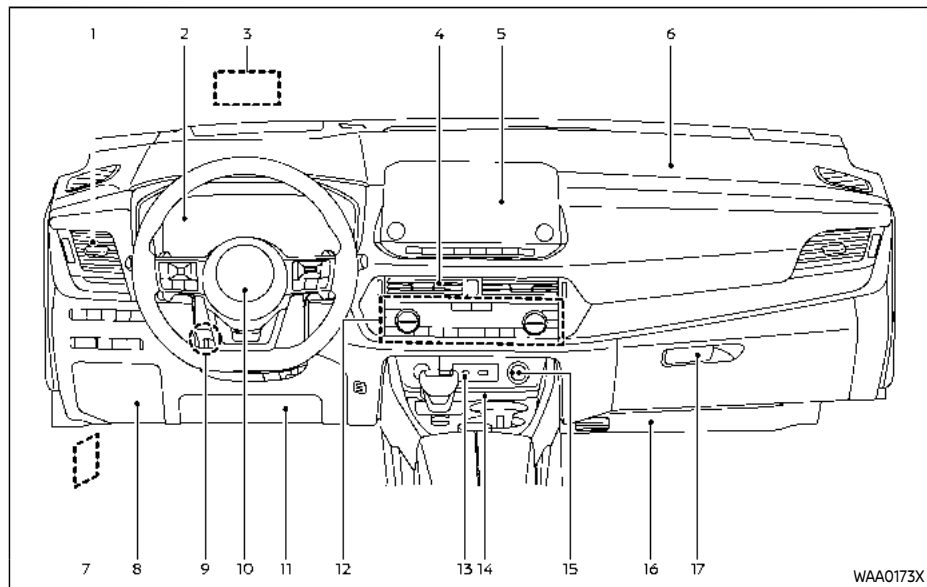

1. Side ventilator
2. Meters and gauges/Clock
3. Head Up Display (HUD)*
4. Center ventilator
5. Audio system** or navigation system**
 - RearView Monitor*
 - Intelligent Around View® Monitor*
6. Front passenger supplemental air bag
7. Hood release handle
8. Fuse box cover
9. Tilt and telescopic steering lock lever
10. Driver supplemental front-impact air bag
11. Driver supplemental knee air bag
12. Heater and air conditioner control
 - Defroster switch
 - Heated seat switches*
 - Heated steering wheel switch*
13. USB (Universal Serial Bus) connection ports**
14. Wireless charger*
15. Power outlet
16. Front passenger supplemental knee air bag
17. Glove box

- *: if so equipped
**: See the separate NissanConnect® Owner's Manual (if so equipped).

METERS AND GAUGES

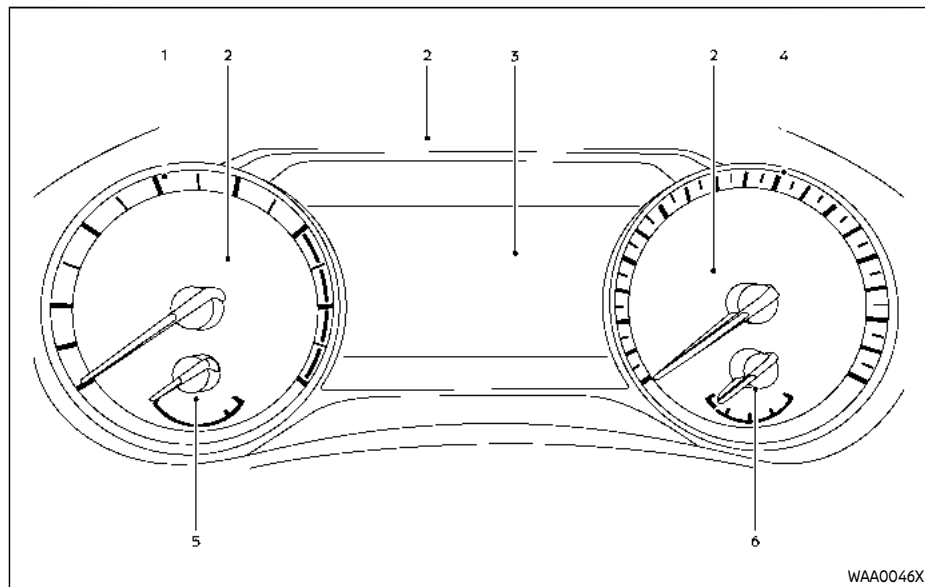

MODELS WITH ANALOG METER AND COLOR DISPLAY



CAUTION

- For cleaning, use a soft cloth, dampened with water. Never use a rough cloth, alcohol, benzene, thinner or any kind of solvent or paper towel with a chemical cleaning agent. They will scratch or cause discoloration to the lens.
- Do not spray any liquid such as water on the meter lens. Spraying liquid may cause the system to malfunction.

1. Tachometer
2. Warning and indicator lights
3. Vehicle information display
 - Odometer
4. Speedometer
5. Engine coolant temperature gauge
6. Fuel gauge

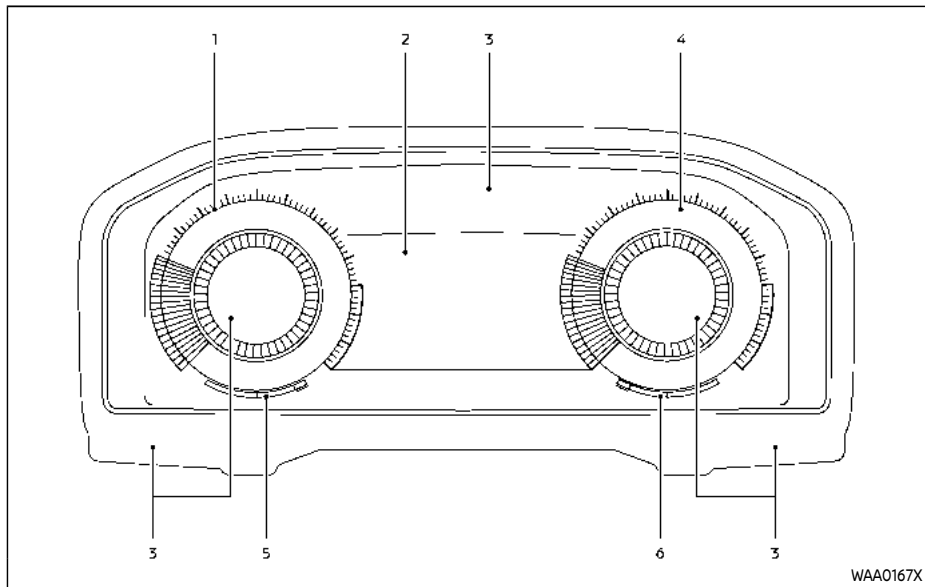

1. Tachometer
2. Vehicle information display
— Odometer
3. Warning and indicator lights
4. Speedometer
5. Engine coolant temperature gauge
6. Fuel gauge

2-6 Instruments and controls

MODELS WITH FULL-SCREEN DISPLAY



CAUTION

- For cleaning, use a soft cloth, dampened with water. Never use a rough cloth, alcohol, benzene, thinner or any kind of solvent or paper towel with a chemical cleaning agent. They will scratch or cause discoloration to the lens.
- Do not spray any liquid such as water on the meter lens. Spraying liquid may cause the system to malfunction.

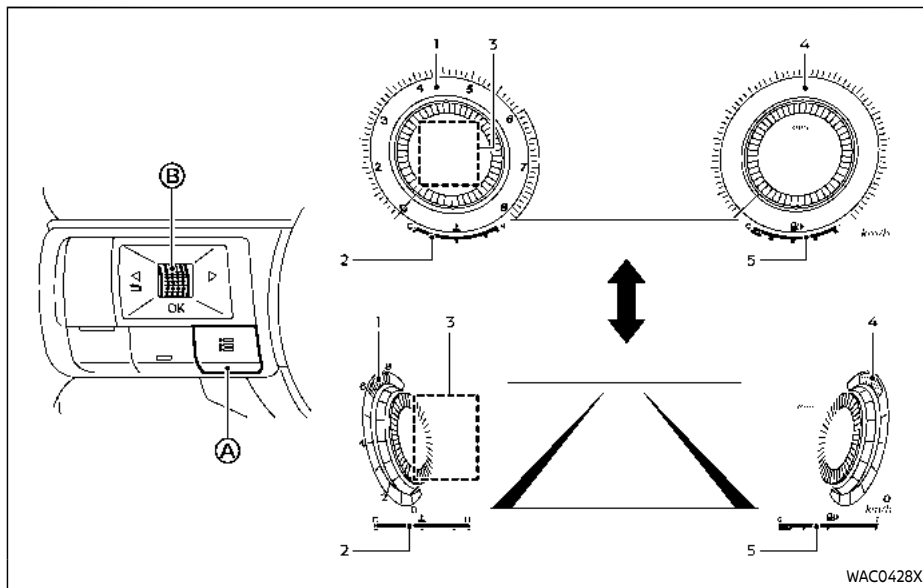

1. Push the shortcut menu button (A) on the left side of the steering wheel.
"Shortcut Menu" appears on the vehicle information display area.
2. Select "Change Meter View" by rotating the scroll dial (B) and push it to change the view.

1. Tachometer
2. Engine coolant temperature gauge
3. Personal Display
4. Speedometer
5. Fuel gauge

Changing the meter screen view (models with full-screen display)

For models with full-screen display, the meter screen view can be changed to expand the vehicle information display area.

To change the meter screen view:

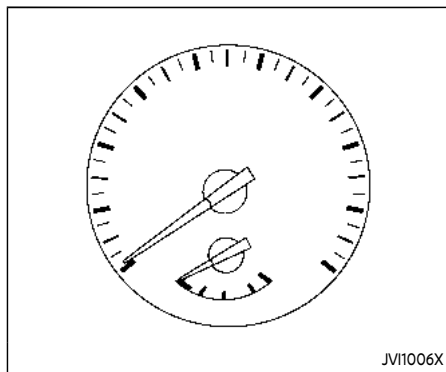

Example

SPEEDOMETER AND ODOMETER

Speedometer

The speedometer indicates vehicle speed in miles per hour (MPH) and kilometers per hour (km/h).

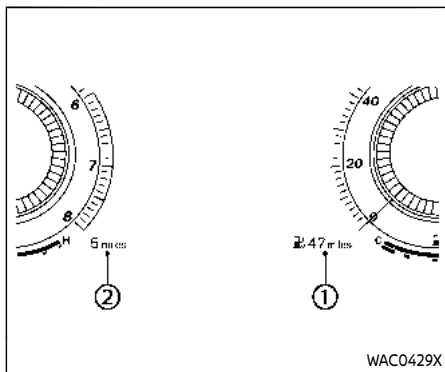

Example

Distance to empty (dte)/Odometer

Distance to empty (dte):

The distance to empty (dte) ① provides an estimation of the distance that can be driven before refueling. The dte is constantly being calculated, based on the amount of fuel in the fuel tank and the actual fuel consumption.

The display is updated every 30 seconds.

The dte mode includes a low range warning feature. If the fuel level is low, the warning is displayed on the screen.

When the fuel level drops even lower, the dte display will change to "----".

- If the amount of fuel added is small, the value displayed just before the ignition switch is placed in the OFF position may continue to be displayed.
- When driving uphill or rounding curves, the fuel in the tank shifts, which may momentarily change the display.

Odometer:

The odometer ② is displayed in the vehicle information display to indicate the total distance the vehicle has been driven.

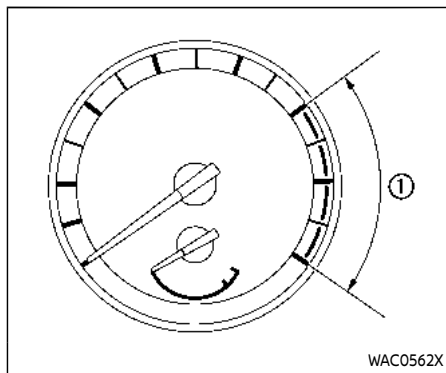

Example

TACHOMETER

The tachometer indicates engine speed in revolutions per minute (RPM). **Do not rev the engine into the red zone ①.**

CAUTION

When engine speed approaches the red zone, shift to a higher gear or reduce engine speed. Operating the engine in the red zone may cause serious engine damage.

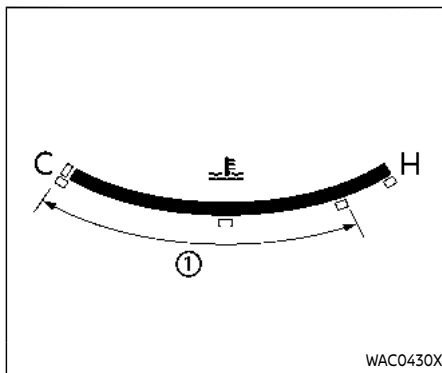

Full-screen model

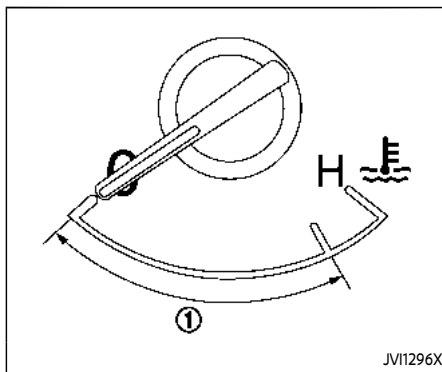

Analog model

ENGINE COOLANT TEMPERATURE GAUGE

The engine coolant temperature gauge indicates the engine coolant temperature.

The engine coolant temperature is normal when the gauge needle points within the zone ① shown in the illustration.

The engine coolant temperature will vary with the outside air temperature and driving conditions.

CAUTION

- If the gauge indicates the engine coolant temperature is near the hot (H) end of the normal range, reduce vehicle speed to decrease the temperature.
- If the gauge is over the normal range, stop the vehicle as soon as safely possible and let the engine idle.
- If the engine is overheated, continued operation of the vehicle may seriously damage the engine. (See "If your vehicle overheats" (P.6-14) for immediate action required.)

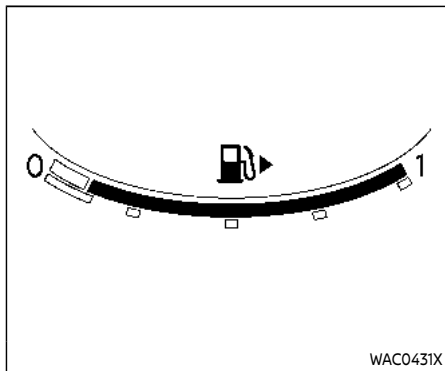

Full-screen model

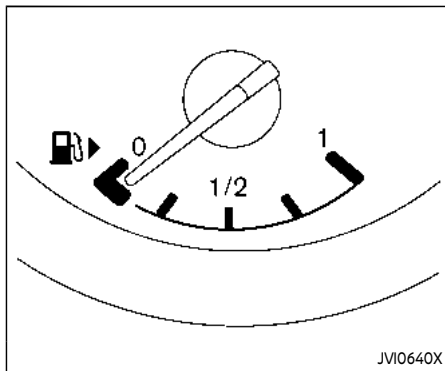



Analog model

FUEL GAUGE

The fuel gauge indicates the approximate fuel level in the tank when the ignition switch is in the ON position.

The gauge may move slightly during braking, turning, accelerating, or going up and down hills due to movement of fuel in the tank.

The low fuel warning  appears on the vehicle information display when the fuel level in the tank is getting low. Refuel as soon as it is convenient, preferably before the gauge reads 0 (empty).

The arrow, , indicates the location of the fuel-filler door.



Refuel before the gauge reads the empty (0) position.

There is a small reserve of fuel in the tank when the fuel gauge reads the empty (0) position.

vehicle inspected. It is recommended you visit a NISSAN dealer for this service.

- **For additional information, see "Malfunction Indicator Light (MIL)" (P.2-19).**

CAUTION

- **If the vehicle runs out of fuel, the  malfunction indicator light (MIL) may come on. Refuel as soon as possible. After a few driving trips, the  light should turn off. If the light remains on after a few driving trips, have the**

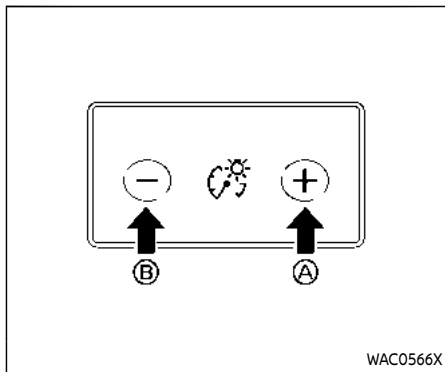

INSTRUMENT BRIGHTNESS CONTROL

The instrument brightness control switch can be operated when the ignition switch is in the ON position. When the switch is operated, the vehicle information display switches to the brightness adjustment mode.

Push the + side of the switch Ⓐ to brighten the instrument panel lights. The bar ① moves to the right side.

Push the - side of the switch Ⓑ to dim the lights. The bar ① moves to the left side.

The vehicle information display returns to the normal display when the instrument brightness control switch is not operated for more than 5 seconds.

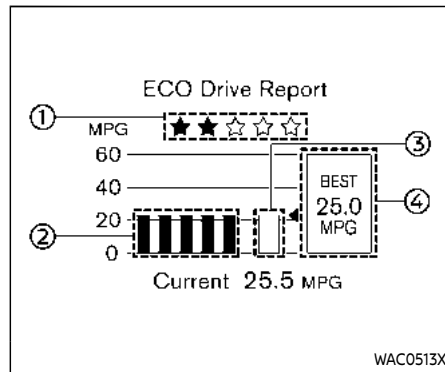
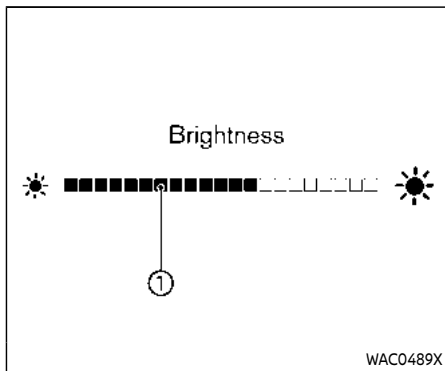

Example

ECO DRIVE REPORT

When the ignition switch is placed in the ON or OFF position, the ECO Drive Report is displayed.

- ① ECO evaluation
- ② Previous 5 times (History)
- ③ Current fuel economy
- ④ Best fuel economy

The result of ECO evaluation is displayed when the vehicle is driven for about 10 minutes or more.

①: The more economically you drive, the more ★ appear.

②: The average fuel economy for the previous 5 times will be displayed.

③: The average fuel economy since the last reset will be displayed.

④: The best fuel economy of the past history will be displayed.

When the “See Tire Pressure” message appears in the ECO Drive Report, the display can be switched to the Tire Pressures display by pushing the scroll dial on the steering wheel to show an additional message. (See “ECO Mode Setting” (P.2-26).)

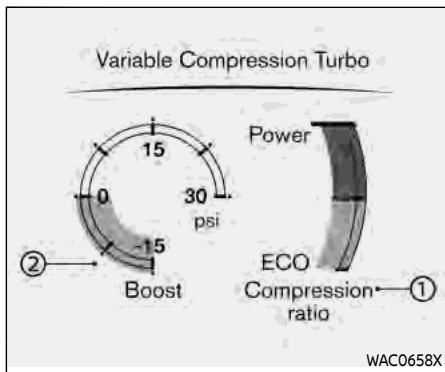

Example

VARIABLE COMPRESSION TURBO (if so equipped)

Your engine is equipped with a variable compression ratio system called “Variable Compression Turbo”. This system can vary the engine compression ratio continuously.

According to driving conditions, the system applies optimum compression ratio automatically to achieve both high output and high fuel economy efficiency.

This is not a physical gauge. It is a display option in the vehicle information display that can be selected. (See “Vehicle information display” (P.2-22).)

① Compression ratio status display

Displays the status of compression ratio controlled by Variable Compression Turbo. The lowest compression ratio (8:1) and the highest (14:1) are displayed as “Power” and “Eco” respectively.

② Turbo charger boost pressure gauge

Displays the turbo charger boost pressure. The unit for the gauge can be changed in the “Settings” menu. (See “Unit/Language” (P.2-31).)

NOTE:































Under some conditions, the compression ratio may not change. This is not a malfunction of the system.



CAUTION







If the Variable Compression Turbo becomes faulty, the Malfunction Indicator Light (MIL) may come on. For additional information, see “Malfunction Indicator Light (MIL)” (P.2-19).

WARNING LIGHTS, INDICATOR LIGHTS AND AUDIBLE REMINDERS









Warning/indicator lights (red)	Warning/indicator lights (yellow)	Warning/indicator lights (other)
 BRAKE	 ABS	 Automatic brake hold indicator light (white)
 Brake warning light (red)	 Anti-lock Braking System (ABS) warning light	 Automatic brake hold indicator light (green)
 Charge warning light	 Automatic Emergency Braking (AEB) system OFF warning light	 Exterior light indicator
 Electric shift control system warning light	 Electric power steering warning light	 Front fog light indicator light (if so equipped)
 PARK	 Electronic parking brake system warning light	 High beam assist indicator light
 Electronic parking brake warning light	 Front passenger air bag status light	 High beam indicator light
 Engine oil pressure warning light	 Low tire pressure warning light	 Turn signal/hazard indicator lights
 Hands OFF warning light (if so equipped)	 Malfunction Indicator Light (MIL)	
 Master warning light	 Master warning light	
 Seat belt warning light and chime	 Rear Automatic Braking (RAB) system OFF warning light	
 Supplemental air bag warning light	 Slip indicator light	
	 Vehicle Dynamic Control (VDC) off indicator light	

CHECKING LIGHTS

With all doors closed, apply the parking brake, fasten the seat belts and place the ignition switch in the ON position without starting the engine. The following lights (if so equipped) will come on:

 , , PARK or  ,  ,  ,  .

The following lights (if so equipped) come on briefly and then go off:

 ,  ,  ,  , ABS or  , , BRAKE or  (red),  (yellow),  .

If any light does not come on or operates in a way other than described, it may indicate a burned-out bulb and/or a system malfunction. It is recommended you have the system checked by a NISSAN dealer.

WARNING/INDICATOR LIGHTS (red)

See "Vehicle information display" (P.2-22).

or Brake warning light

This light functions for both the parking brake and the foot brake systems.

Low brake fluid warning light:

When the ignition switch is placed in the ON position, the brake warning light illuminates, and then turns off. If the light illuminates while the engine is running with the parking brake not applied, stop the vehicle and perform the following:

1. Check the brake fluid level. If brake fluid is necessary, add fluid and have the system checked. It is recommended you have this service performed by a NISSAN dealer. (See "Brake fluid" (P.8-12).)
2. If the brake fluid level is correct, have the warning system checked. It is recommended you have this service performed by a NISSAN dealer.

Anti-lock Braking System (ABS) warning indicator:

When the parking brake is released and the brake fluid level is sufficient, if both the brake warning light and the Anti-lock Braking System (ABS) warning light illuminate, it may indicate the ABS is not functioning properly. Have the brake system checked, and if necessary repaired. It is recommended you visit a

NISSAN dealer for this service. (See "Anti-lock Braking System (ABS) warning light" (P.2-17).)



WARNING

- **Your brake system may not be working properly if the warning light is on. Driving could be dangerous. If you judge it to be safe, drive carefully to the nearest service station for repairs. Otherwise, have your vehicle towed because driving it could be dangerous.**
- **Pressing the brake pedal with the engine stopped and/or low brake fluid level may increase your stopping distance and braking will require greater pedal effort as well as pedal travel.**
- **If the brake fluid level is below the minimum or MIN mark on the brake fluid reservoir, do not drive until the brake system has been checked. It is recommended you visit a NISSAN dealer for this service.**



Charge warning light

When the ignition switch is in the ON position, the charge warning light illuminates and then turns off.

If the light illuminates while the engine is running, it may indicate the charging system is not functioning properly. Turn the engine off and check the alternator belt. If the belt is loose, broken, missing or if the light remains on, have your vehicle serviced immediately. It is recommended you visit a NISSAN dealer for this service.



CAUTION

Do not continue driving if the alternator belt is loose, broken or missing.



Electric shift control system warning light

When the ignition switch is in the ON position, the electric shift control system warning light illuminates, and then turns off. This indicates the electric shift control system is operational.

The electric shift control system warning light illuminates when a malfunction oc-

curs in the electric shift control system. When the master warning light illuminates, the chime sounds and the following message is displayed in the vehicle information display: "When parked apply parking brake".

When the ignition switch is placed in the OFF position, the chime sounds continuously. Ensure the parking brake is applied. Have the system checked by a NISSAN dealer.



(P) or PARK Electronic parking brake warning light

The electronic parking brake warning light indicates that the electronic parking brake system is operating.

When the ignition switch is placed in the ON position, the electronic parking brake warning light illuminates. When the engine is started and the parking brake is released, the warning light turns off.

If the parking brake is not released, the electronic parking brake warning light remains on. Be sure that the electronic parking brake warning light has turned off before driving. (See "Parking brake" (P.5-25).)

If the electronic parking brake warning light illuminates or flashes while the electronic parking brake system warning

light  illuminates, it may indicate that the electronic parking brake system is not functioning properly. Have the system checked, and if necessary repaired. It is recommended you visit a NISSAN dealer for this service.



Engine oil pressure warning light

This light warns of low engine oil pressure. When the ignition switch is in the ON position, the engine oil pressure warning light illuminates. After starting the engine, the engine oil pressure warning light turns off. This indicates that the oil pressure sensors in the engine are operational.

If the engine oil pressure warning light illuminates or blinks while the engine is running, it may indicate that the engine oil pressure is low.

Stop the vehicle safely as soon as possible. Stop the engine immediately and call a NISSAN dealer.



CAUTION

- **Running the engine with the engine oil pressure warning light illuminated could cause serious damage to the engine.**

- **The engine oil pressure warning light is not designed to indicate a low oil level. The oil level should be checked using the dipstick. (See "Engine oil" (P.8-8).)**

Hands OFF warning light (if so equipped)

When the Steering Assist is activated, it monitors the driver's steering wheel operation. If the steering wheel is not operated or the driver takes his/her hands off the steering wheel for a period of time, the warning light illuminates. If the driver does not operate the steering wheel after the warning light has been illuminated, an audible alert sounds and the warning flashes in the vehicle information display, followed by a quick brake application to request the driver to take control of the vehicle again. If the driver remains unresponsive, the vehicle will automatically turn on the hazard lights and slow to a complete stop. (See "Steering Assist" (P.5-113).)

Master warning light

When the ignition switch is in the ON position, the master warning light illuminates if a warning message appears in the vehicle information display.

See "Vehicle information display" (P.2-22).

Seat belt warning light and chime

The light and chime remind you to fasten the seat belts.

The light illuminates whenever the ignition switch is placed in the ON position, and will remain illuminated until the seat belts are fastened.

The seat belt warning light for the front passenger will illuminate if the seat belt is not fastened when the front passenger's seat is occupied.

When the vehicle speed exceeds 10 MPH (15 km/h), the light will continue to blink and the chime will sound for about 95 seconds until the driver's and, if occupied, front passenger's seat belts are securely fastened.

When the ignition switch is placed in the ON position, the chime will sound for about 6 seconds unless the driver's seat belt is securely fastened.

When the vehicle speed exceeds 10 MPH (15 km/h), the chime will sound unless the rear passenger's seat belts are securely fastened. The chime will continue to sound for about 35 seconds until the rear passenger's seat belts are fastened.

For additional information, refer to "Seat belt warning light and chime" (P.1-17).

Supplemental air bag warning light

After placing the ignition switch in the ON position, the supplemental air bag warning light will illuminate. The supplemental air bag warning light will turn off after about 7 seconds if the supplemental front air bag and supplemental side air bag, curtain air bag systems and/or pretensioner seat belt are operational.

If any of the following conditions occur, the front air bag, side air bag, curtain air bag and pretensioner systems need servicing.

- The supplemental air bag warning light remains on after approximately 7 seconds.
- The supplemental air bag warning light flashes intermittently.
- The supplemental air bag warning light does not illuminate at all.

It is recommended you visit a NISSAN

dealer for these services.

Unless checked and repaired, the Supplemental Restraint Systems and/or the pretensioners may not function properly.

For additional information, see "Supplemental Restraint System (SRS)" (P.1-47).



WARNING

If the supplemental air bag warning light is on, it could mean that the front air bag, side air bag, curtain air bag and/or pretensioner systems will not operate in an accident. To help avoid injury to yourself or others, have your vehicle checked. It is recommended you visit a NISSAN dealer for this service.

WARNING/INDICATOR LIGHTS (yellow)

See "Vehicle information display" (P.2-22).

or Anti-lock Braking System (ABS) warning light

When the ignition switch is in the ON position, the Anti-lock Braking System (ABS) warning light illuminates and then turns off. This indicates the ABS is operational.

If the ABS warning light illuminates while the engine is running, or while driving, it may indicate the ABS is not functioning properly. Have the system checked. It is recommended you visit a NISSAN dealer for this service.

If an ABS malfunction occurs, the anti-lock function is turned off. The brake system then operates normally, but without anti-lock assistance. (See "Brake system" (P.5-155).)



Automatic Emergency Braking (AEB) system OFF warning light

When the ignition switch is in the ON position, the AEB system OFF warning light illuminates. After starting the engine, the warning light turns off.

This light illuminates when the AEB with Pedestrian Detection system is set to OFF on the vehicle information display.

If the light illuminates or flashes when the AEB with Pedestrian Detection system is ON, it may indicate that the system is unavailable. See "Automatic Emergency Braking (AEB) with Pedestrian Detection system" (P.5-122) or "Intelligent Forward Collision Warning (I-FCW)" (P.5-132).



Electric power steering warning light

When the ignition switch is in the ON position, the electric power steering warning light illuminates. After starting the engine, the electric power steering warning light turns off. This indicates the electric power steering is operational.

If the electric power steering warning light illuminates while the engine is running, it may indicate the electric power steering is not functioning properly and may need servicing. Have the system checked. It is recommended that you visit a NISSAN dealer for this service.

When the electric power steering warning light illuminates with the engine running, the power assist to the steering will cease operation but you will still have control of the vehicle. At this time, greater steering efforts are required to operate the steering wheel, especially in sharp turns and at low speeds.

(See "Electric power steering" (P.5-154).)

Electronic parking brake system warning light

When the ignition switch is in the ON position, the electronic parking brake system warning light illuminates and then turns off.

The electronic parking brake system warning light functions for the electronic parking brake system. If the warning light illuminates, it may indicate that the electronic parking brake system is not functioning properly. Have the brake system checked, and, if necessary, repaired. It is recommended that you visit a NISSAN dealer for this service.

Front passenger air bag status light

The front passenger air bag status light will be lit and the front passenger air bag and the front passenger knee air bag will be off depending on how the front passenger seat is being used.

For additional information, see "Front passenger air bag and status light" (P.1-55).

Low tire pressure warning light

Your vehicle is equipped with a Tire Pressure Monitoring System (TPMS) that monitors the tire pressure of all tires except the spare tire.

The low tire pressure warning light warns of low tire pressure or indicates that the TPMS is not functioning properly.

After the ignition switch is placed in the ON position, this light illuminates for about 1 second and turns off.

Low tire pressure warning:

If the vehicle is being driven with low tire pressure, the warning light will illuminate. The "Tire Pressure Low - Add Air" warning also appears in the vehicle information display.

When the low tire pressure warning light illuminates, you should stop and adjust the tire pressure to the recommended COLD tire pressure shown on the Tire and Loading Information label. The low tire pressure warning light does not automatically turn off when the tire pressure is adjusted. After the tire is inflated to the recommended pressure, the vehicle must be driven at speeds above 16 MPH (25 km/h) to activate the TPMS and turn off the low tire pressure warning light. Use a

tire pressure gauge to check the tire pressure.

The "Tire Pressure Low - Add Air" warning is active as long as the low tire pressure warning light remains illuminated.

For additional information, see "Vehicle information display" (P.2-22), "Tire Pressure Monitoring System (TPMS)" (P.5-6) and "Tire Pressure Monitoring System (TPMS)" (P.6-3).

TPMS malfunction:

If the TPMS is not functioning properly, the low tire pressure warning light will flash for approximately 1 minute when the ignition switch is placed in the ON position. The light will remain on after the 1 minute. Have the system checked. It is recommended you visit a NISSAN dealer for this service. The "Tire Pressure Low - Add Air" warning does not appear if the low tire pressure warning light illuminates to indicate a TPMS malfunction.

For additional information, see "Tire Pressure Monitoring System (TPMS)" (P.5-6).



WARNING

- **If the light does not illuminate with the ignition switch placed in the ON position, have the vehicle**

checked. It is recommended you visit a NISSAN dealer for this service as soon as possible.

- If the light illuminates while driving, avoid sudden steering maneuvers or abrupt braking, reduce vehicle speed, pull off the road to a safe location and stop the vehicle as soon as possible. Driving with under-inflated tires may permanently damage the tires and increase the likelihood of tire failure. Serious vehicle damage could occur and may lead to an accident and could result in serious personal injury. Check the tire pressure for all four tires. Adjust the tire pressure to the recommended COLD tire pressure shown on the Tire and Loading Information label to turn the low tire pressure warning light OFF. If the light still illuminates while driving after adjusting the tire pressure, a tire may be flat or the TPMS may be malfunctioning. If you have a flat tire, replace it with a spare tire as soon as possible. If no tire is flat and all tires are properly inflated, it is recommended you consult a NISSAN dealer.

- Since the spare tire is not equipped with the TPMS, when a spare tire is mounted or a wheel is replaced, the TPMS will not function and the low tire pressure warning light will flash for approximately 1 minute. The light will remain on after 1 minute. Have your tires replaced and/or TPMS system reset as soon as possible. It is recommended you visit a NISSAN dealer for these services.
- Replacing tires with those not originally specified by NISSAN could affect the proper operation of the TPMS.



CAUTION

- The TPMS is not a substitute for the regular tire pressure check. Be sure to check the tire pressure regularly.
- If the vehicle is being driven at speeds of less than 16 MPH (25 km/h), the TPMS may not operate correctly.

- Be sure to install the specified size of tires to the four wheels correctly.



Malfunction Indicator Light (MIL)

If the malfunction indicator light comes on steady or blinks while the engine is running, it may indicate a potential emission control and/or Continuously Variable Transmission (CVT) malfunction.

The malfunction indicator light may also illuminate steady if the vehicle runs out of fuel. Check to make sure that the vehicle has at least 3 US gallons (11.4 liters) of fuel in the fuel tank.

After a few driving trips, the  light should turn off if no other potential emission control system malfunction exists.

If this indicator light remains on for 20 seconds and then blinks for 10 seconds when the engine is not running, it indicates that the vehicle is not ready for an emission control system inspection/maintenance test. (See "Readiness for Inspection/Maintenance (I/M) test" (P.10-31).)

Operation:

The malfunction indicator light will come on in one of two ways:

- Malfunction indicator light on steady – An emission control system and/or CVT malfunction has been detected. It is recommended you visit a NISSAN dealer for this service. You do not need to have your vehicle towed to the dealer.
- Malfunction indicator light blinking – An engine misfire has been detected which may damage the emission control system.

To reduce or avoid emission control system damage:

- 1) Do not drive at speeds above 45 MPH (72 km/h).
- 2) Avoid hard acceleration or deceleration.
- 3) Avoid steep uphill grades.
- 4) If possible, reduce the amount of cargo being hauled or towed.

The malfunction indicator light may stop blinking and remain on.

Have the vehicle inspected. It is recommended you visit a NISSAN dealer for this service. You do not need to have your vehicle towed to the dealer.



CAUTION

Continued vehicle operation without having the emission control system and/or CVT system checked and repaired as necessary could lead to poor driveability, reduced fuel economy, and possible damage to the emission control system.



Master warning light

When the ignition switch is in the ON position, the master warning light illuminates if a warning message appears in the vehicle information display.

See "Vehicle information display" (P.2-22).



Rear Automatic Braking (RAB) system OFF warning light

This light comes on when the ignition switch is placed in the ON position. It turns off after the engine is started.

This light illuminates when the RAB system is turned off in the vehicle information display.

If the light illuminates when the RAB system is on, it may indicate that the system is unavailable. For additional in-

formation, see "Rear Automatic Braking (RAB)" (P.5-143).



Slip indicator light

When the ignition switch is in the ON position, the slip indicator light illuminates and then turns off.

The light will blink when the Vehicle Dynamic Control (VDC) system or the traction control system is operating, thus alerting the driver that the vehicle is nearing its traction limits. The road surface may be slippery.

If the light illuminates while the VDC system is on, this light alerts the driver to the fact that the VDC system's fail-safe mode is operating, for example the VDC system may not be functioning properly. Have the system checked. It is recommended you visit a NISSAN dealer for this service. If a malfunction occurs in the system, the VDC system function will be canceled but the vehicle is still driveable. For additional information, see "Vehicle Dynamic Control (VDC) system" (P.5-157) of this manual.



Vehicle Dynamic Control (VDC) off indicator light

The light comes on when the VDC is turned OFF. This indicates that the VDC system and traction control system are not operating.

Turn the VDC on using the vehicle information display, or restart the engine and the system will operate normally. (See "Vehicle Dynamic Control (VDC) system" (P.5-157).)

The light also comes on when placing the ignition switch in the ON position. The light will turn off after about 2 seconds if the system is operational. If the light stays on or comes on along with the  indicator light while you are driving, have the VDC system checked. It is recommended that you visit a NISSAN dealer for this service.



WARNING

The VDC should remain on unless freeing a vehicle from mud or snow.

While the VDC system is operating, you might feel a slight vibration or hear the system working when starting the vehicle or accelerating, but this is not a malfunc-

tion.

WARNING/INDICATOR LIGHTS (other)

See "Vehicle information display" (P.2-22).



Automatic brake hold indicator light (white)

The automatic brake hold indicator light (white) illuminates when the automatic brake hold system is on standby. (See "Automatic brake hold" (P.5-28).)





Automatic brake hold indicator light (green)

The automatic brake hold indicator light (green) illuminates when the automatic brake hold system is operating. (See "Automatic brake hold" (P.5-28).)



Exterior light indicator

This indicator illuminates when the headlight switch is turned to the AUTO,  or  position and the front parking lights, rear combination lights, license plate lights or headlights are on. The indicator turns off when these lights are turned off.



Front fog light indicator light (if so equipped)

The front fog light indicator light illuminates when the front fog lights are on. (See "Fog light switch" (P.2-65).)



High beam assist indicator light

The high beam assist indicator light illuminates when the high beam assist system is turned on and it is operational. (See "High beam assist" (P.2-61).)



High beam indicator light

This light illuminates when the headlight high beam is on and goes out when the low beam is selected.





Turn signal/hazard indicator lights

The light flashes when the turn signal switch lever or hazard switch is turned on.

AUDIBLE REMINDERS

Light reminder chime

The light reminder chime will sound when the headlight switch is placed in the  or  position after the engine was turned off, and the driver's door is opened with the light is on.

Turn the light switch to the OFF (if so equipped) or AUTO position when you leave the vehicle.

Driving Aid chimes (if so equipped)

An audible alert/chime may be heard if any of the following systems (if so equipped) are active:

- Lane Departure Warning (LDW)
- Intelligent Lane Intervention (I-LI)
- Blind Spot Warning (BSW)
- Intelligent Blind Spot Intervention (I-BSI)
- Rear Cross Traffic Alert (RCTA)
- ProPILOT Assist
- Automatic Emergency Braking (AEB) with Pedestrian Detection
- Intelligent Forward Collision Warning (I-FCW)
- Rear Automatic Braking (RAB)
- Sonar system

- Rear Sonar System (RSS)

For additional information, refer to the "5. Starting and driving" section of this manual.

Door lock warning chime

When the chime sounds, be sure to check both the vehicle and the Intelligent Key. See "Troubleshooting guide" (P.3-13).

Brake pad wear warning

The disc brake pads have audible wear warnings. When a brake pad requires replacement, it will make a high pitched scraping sound when the vehicle is in motion. This scraping sound will first occur only when the brake pedal is depressed. After more wear of the brake pad, the sound will always be heard even if the brake pedal is not depressed. Have the brakes checked as soon as possible if the warning sound is heard.

VEHICLE INFORMATION DISPLAY

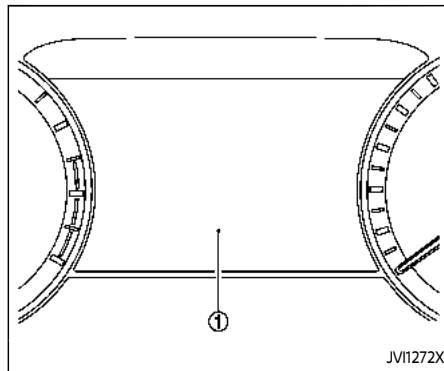

Example

The vehicle information display ① is located as shown above, and it displays the warnings and information. The following items are also displayed if the vehicle is equipped with them:

- Tachometer
- Speedometer
- Vehicle settings
- Trip computer information
- Driver Assistance
- Cruise control system information
- ProPILOT Assist
- Intelligent Key operation information

- Audio information
- Navigation - turn by turn
- Indicators and warnings
- Tire pressure information
- Other information

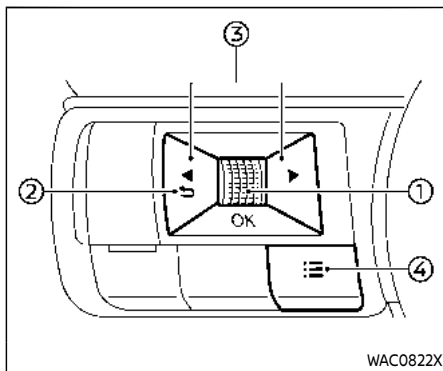

HOW TO USE THE VEHICLE INFORMATION DISPLAY

The vehicle information display can be changed using the dial and buttons located on the steering wheel.

- ① Scroll dial - navigate through the items and change or select an item in vehicle information display
this scroll dial allows up/down navigation and push to select
- ② ↻ - go back to the previous menu
- ③ ◀ ▶ - change from one display screen category to the next (i.e. trip, Fuel economy)
- ④ ☰ - display the "Shortcut Menu" screen

SHORTCUT MENU

When the ☰ button ④ is pushed, the "Shortcut Menu" screen appears on the vehicle information display. Select the menu by rotating the scroll dial ① and push it.

The following menus are available:

- Change Meter View (if so equipped)
Allows user to change the meter screen view. (See "Changing the meter screen view (models with full-screen display)" (P.2-7).)
- Audio Source
Allows user to select the available audio source. (See the separate NissanConnect® Owner's Manual for the audio system.)
- Driver Assistance
Allows user to change the "Driver Assistance" settings. (See "Driver Assistance" (P.2-24).)
- Personal Display (if so equipped)
Allows user to change the "Personal Display" settings. (See "Personal Display" (P.2-26).)

STARTUP DISPLAY

When the ignition switch is placed in the ON position, the vehicle information display may display the following screens if the vehicle is equipped with them:

- Home
- Blank
- Vehicle Speed
- Drive Computer
- Fuel Economy
- ECO Pedal Guide
- Tire Pressures
- 4x4-i
- Variable Compression Turbo
- Navigation
- Compass
- Audio
- Driving Aids
- ProPILOT Assist
- Speed Limit Sign
- Warnings
- Settings

Warnings will only display if there are any present. For more information on warnings and indicators, see "Vehicle information display warnings and indicators" (P.2-35).

To control what items display in the vehicle information display, see "Settings"

(P.2-24).

SETTINGS

The setting mode allows user to change the information displayed in the vehicle information display and some settings:

- VDC Setting
- Driver Assistance
- Personal Display (if so equipped)
- Head-Up Display (if so equipped)
- ECO Mode Setting
- TPMS Setting
- Clock
- Vehicle Settings
- Maintenance
- Customize Display
- Unit/Language
- Key-Linked Settings (if so equipped)
- Factory Reset

VDC Setting

To change the setting, use the scroll dial ① to select and push it.

- System
Allows user to turn the Vehicle Dynamic Control (VDC) system ON or OFF. By default the VDC system will be turned ON. If the VDC system is turned off, the VDC OFF indicator light will illuminate.

NOTE:

The vehicle should be driven with the Vehicle Dynamic Control (VDC) system ON for most driving conditions. (See "Vehicle Dynamic Control (VDC) system" (P.5-157).)

Driver Assistance

To change the status, warnings or turn on or off any of the systems/warnings displayed in the "Driver Assistance" menu, use the scroll dial ① to select and change a menu item:

- Steering Assist (if so equipped)
- Lane Assist
- Blind Spot Assist
- Emergency Assist
- Speed Limit Sign (if so equipped)
- Speed Adjust by Route (if so equipped)
- Spd. Limit Assist (if so equipped)
- Parking Assist
- Rear Cross Traffic Alert
- Driver Alertness
- Timer Alert
- Low Temp. Alert

Steering Assist (if so equipped):

- Allows user to turn the Steering Assist ON/OFF.

(See "ProPILOT Assist" (P.5-85).)

Lane Assist:

- Warning
Allows user to turn the Lane Departure Warning (LDW) system ON/OFF.
- Intervention (if so equipped)
Allows user to turn the Intelligent Lane Intervention (I-LI) system ON/OFF.
- Steering Vibration
Allows user to select the strength of the steering wheel vibration (High, Mid. or Low).

(See "Lane Departure Warning (LDW)" (P.5-47) and "Intelligent Lane Intervention (I-LI)" (P.5-115).)

Blind Spot Assist:

- Warning
Allows user to turn the Blind Spot Warning (BSW) system ON/OFF.
- Intervention (if so equipped)
Allows user to turn the Intelligent Blind Spot Intervention (I-BSI) system ON/OFF.

(See "Blind Spot Warning (BSW)" (P.5-58) and "Intelligent Blind Spot Intervention (I-BSI)" (P.5-66).)

Emergency Assist:

- Emergency Braking
Allows user to turn the Automatic Emergency Braking (AEB) with Pedes-

trian Detection system and Intelligent Forward Collision Warning (I-FCW) system ON/OFF.

- Rear Auto Braking
Allows user to turn the Rear Automatic Braking (RAB) system ON/OFF.
(See "Automatic Emergency Braking (AEB) with Pedestrian Detection system" (P.5-122), "Intelligent Forward Collision Warning (I-FCW)" (P.5-132) and "Rear Automatic Braking (RAB)" (P.5-143).)

Speed Limit Sign (if so equipped):

Allows user to turn the Traffic Sign Recognition (TSR) ON/OFF. (See "Traffic Sign Recognition (TSR)" (P.5-44).)

Speed Adjust by Route (if so equipped):

Allows user to turn the Speed Adjust by Route (ProPILOT Assist with Navi-link) function ON/OFF. (See "Speed Limit Assist - a feature of ProPILOT Assist with Navi-link" (P.5-103).)

Spd.Limit Assist (if so equipped):

Allows user to customize the Speed Limit Assist (ProPILOT Assist with Navi-link) options.

- OFF
- Manual
- Auto

(See "Speed Limit Assist - a feature of

ProPILOT Assist with Navi-link" (P.5-103).)

Parking Assist:

To change the status or turn on or off any of the systems displayed in the "Parking Assist" menu, use the scroll dial ① to select and change a menu item:

- Moving Object (if so equipped)
Allows user to turn the Moving Object Detection (MOD) ON/OFF.
- Auto Show Sonar (if so equipped)
Allows user to turn the sonar system or the Rear Sonar System (RSS) display ON/OFF.
- Front Sonar (if so equipped)
Allows user to turn the front sonar sensors ON/OFF.
- Rear Sonar
Allows user to turn the rear sonar sensors ON/OFF.
- Side Sonar (if so equipped)
Allows user to turn the side sonar sensors ON/OFF.
- Sonar Distance
Allows user to select the sonar sensor's detection distance (Long, Medium or Short).
- Sonar Volume
Allows user to select the volume of the sonar tone (High, Medium or Low).

(See "Moving Object Detection (MOD)"

(P.4-22), "Sonar system" (P.5-162) and "Rear Sonar System (RSS)" (P.5-168.)

Rear Cross Traffic Alert:

Allows user to turn the Rear Cross Traffic Alert (RCTA) system ON/OFF. (See "Rear Cross Traffic Alert (RCTA)" (P.5-77).)

Driver Alertness:

Allows user to turn the Intelligent Driver Alertness (I-DA) on or off. (See "Intelligent Driver Alertness (I-DA)" (P.5-141).)

Timer Alert:

Allows user to adjust the Timer Alert or reset.

- (Current Time)/(Set Time)
- Reset

Low Temp. Alert:

Allows user to turn the Low Temperature Alert function ON/OFF.

Personal Display (if so equipped)

To change the display in the "Personal Display" menu, use the scroll dial ① to select and change a menu item:

- Blank
- Navigation
- Time to Destination
- Fuel Economy

- Manual Reset1
- Manual Reset2
- Auto Refuel

- Trip
 - Manual Reset1
 - Manual Reset2
 - Auto Refuel
- Gear position
- Average speed
 - Manual Reset1
 - Manual Reset2
 - Auto Refuel

Head-Up Display (if so equipped)

To change the status or turn on or off any of the systems displayed in the "Head-Up Display" menu, use the scroll dial ① to select and change a menu item:

- Brightness
- Height
- Rotation
- Contents selection
 - Navigation (if so equipped)
 - Driving Assist
 - Speed Limit Sign
 - Audio
 - TEL/SMS
- Reset

(See "Head Up Display (HUD)" (P.2-50).)

ECO Mode Setting

This setting allows user to change the ECO mode system settings.

To change the status or turn on or off any of the systems displayed in the "ECO Mode Settings" menu, use the scroll dial ① to select and change a menu item:

- ECO Customize
 - Cruise Control
- ECO Drive Assist
 - ECO Indicator
 - ECO Drive Report
- View History
 - To reset the View History:
 - 1) Select "View History" using the scroll dial ① and push it.
 - 2) Push the scroll dial ①.
 - 3) Select "Yes" by pushing the scroll dial ①.
- Tire Pres ECO advice
 - Push the scroll dial ① to turn the "Tire Pres ECO advice" ON/OFF.

TPMS Setting

The following submenu appears.

Tire Pressure Unit:

The unit for tire pressure that is shown in the vehicle information display can be changed to:

- psi
- kPa
- bar
- kgf/cm²

Use the scroll dial ① to select and change the unit.

If necessary, refer to the following table to convert between units.

kPa	200	210	220	230	240	250	260	270	280	290	300	310	320	330	340
psi	29	30	32	33	35	36	38	39	41	42	44	45	46	48	49
bar	2.0	2.1	2.2	2.3	2.4	2.5	2.6	2.7	2.8	2.9	3.0	3.1	3.2	3.3	3.4
kgf/cm ²	2.0	2.1	2.2	2.3	2.4	2.5	2.6	2.7	2.8	2.9	3.0	3.1	3.2	3.3	3.4

JVI0938X

When the tire pressure unit is changed, the unit for the turbo charger boost pressure gauge (if so equipped) is also changed. (See "Variable Compression Turbo" (P.2-12).)

Clock

Allows user to adjust the clock settings and time within the vehicle information display.

- Clock Mode (if so equipped)
- Clock Format
- Daylight Saving (if so equipped)
- Time Zone (if so equipped)

- Set Clock Manually

The clock may also be set in the center display. For additional information, refer to the separate NissanConnect® Owner's Manual.

Vehicle Settings

The vehicle settings allows user to change settings for the following menus.

- Power Back Door (if so equipped)
- Lighting
- Locking
- Wipers
- Driving Position (if so equipped)
- Rear Door Alert

The vehicle settings can be changed using the scroll dial ①.

Power Back Door (if so equipped):

This allows user to turn the power liftgate ON or OFF.

Lighting:

The "Lighting" menu has the following options:

- Welcome Headlight
The welcome lighting can be set to be ON or OFF. Use the scroll dial ① to turn this feature ON or OFF.
- Auto Room Lamp
The interior light can be set to be ON or OFF. Use the scroll dial ① to turn this feature ON or OFF.
- Accent Lighting (if so equipped)
The brightness of the Accent Lighting can be adjusted. Use the scroll dial ① to select the brightness.

- Auto Headlight
The sensitivity of the Intelligent Auto Headlight can be adjusted. Use the scroll dial ① to select the required sensitivity. The following options are available:
 - Turn on earliest
 - Turn on earlier
 - Turn on standard
 - Turn on later
- Light Off Delay
The duration of the automatic headlights can be changed from 0 to 180 seconds. Use the scroll dial ① to change the duration.

Locking:

The "Locking" menu has the following options:

- Ext. Door Switch (if so equipped)
When this item is turned on, the request switch on the door is activated. Use the scroll dial ① to activate or deactivate this function.
- Selective Unlock (if so equipped)
When this item is turned on, and the door handle request switch on the driver's side door or the liftgate request switch is pushed, only the corresponding door/liftgate is unlocked. All the doors can be unlocked

if the same request switch is pushed again within 1 minute. When this item is turned to off, all the doors will be unlocked when the request switch is pushed once. Use the scroll dial ① to activate or deactivate this function.

- Auto Door Unlock
The "Auto Door Unlock" feature allows user to customize the auto door unlock options. Use the scroll dial ① to change the mode.
 - Shift to P
 - IGN OFF
 - OFF
- Horn beeps on lock (if so equipped)
When this item is turned on, the horn will chirp and the hazard indicators will flash twice when locking the vehicle with the Intelligent Key. Use the scroll dial ① to activate or deactivate this function.

Wipers:

The "Wipers" menu has the following options:

- Speed Dependent
The "Speed Dependent" feature can be activated or deactivated. Use the scroll dial ① to turn this feature ON or OFF.

- Reverse Link

The "Reverse Link" wiper feature can be set to be ON or OFF. Use the scroll dial ① to turn this feature ON or OFF.

Driving Position (if so equipped):

- Exit Seat Slide

This allows user to turn the entry/exit function ON or OFF. Use the scroll dial ① to turn this function ON or OFF. (See "Memory seat" (P.3-37).)

Rear Door Alert:

The "Rear Door Alert" feature allows user to customize the Rear Door Alert options. Use the scroll dial ① to change the mode.

- Horn & Alert

When selected, the alert is displayed and the horn sounds.

- Alert Only

When selected, only the alert is displayed.

- OFF

When selected, no alert or horn will be active.

(See "Rear Door Alert" (P.2-68).)

Maintenance

The maintenance mode allows user to check the distance to oil change or set alerts for the reminding of maintenance intervals. To change an item:

Select "Maintenance" using the scroll dial ① and push it.

- Oil Control System
- Oil and Filter
- Tire
- Other

Oil Control System:

The Oil Control System informs the distance to oil change. Never exceed one year or the following distance between oil change intervals:

- 10,000 miles (16,000 km) for the PR25DD engine
- 7,500 miles (12,000 km) for the KR15DDT engine

Display when ignition is ON	Display timing	Action Required
Engine Oil Service due in xxx miles	Remaining oil life is less than 940 miles (1,500 km).	Plan to have your vehicle serviced.
Engine Oil Service due	Remaining oil life is 0 miles (0 km).	Have your vehicle serviced within two weeks or less than 500 miles (800 km).

The oil change interval cannot be adjusted manually.

The distance to oil change interval is calculated depending on the driving conditions and set automatically by the oil control system. A reminder will be displayed when approaching the end of the service interval.

When the Factory Reset option is selected in the vehicle information display, the oil control system will also be reset to initial value. Please change the engine oil when Factory Reset is selected.

 **CAUTION**

If the oil replacement indicator is displayed, change the engine oil within two weeks or less than 500 miles (800 km).

Operating the vehicle with deteriorated oil can damage the engine.

To reset oil control system:

1. Place the ignition switch in the ON position.
2. Push the ◀ and ▶ buttons on the steering wheel until “Settings” appears in the vehicle information display. Use the scroll dial to select “Maintenance”. Then, push the scroll dial.
3. Select the “Oil Control System” and push the scroll dial.
4. Push the scroll dial according to the reset instructions displayed at the bottom of the “Oil Control System” maintenance screen.

When the user sets an alert for changing the engine oil in the “Oil and Filter” menu, reset both “Oil Control System” and “Oil and Filter” after changing the engine oil.

Oil and Filter:

This indicator appears when user set distance comes for changing the engine oil and filter. You can set or reset the distance for checking or replacing these items. For scheduled maintenance items and intervals, refer to the “9. Maintenance and schedules” section.

When the user sets an alert for changing the engine oil in the “Oil and Filter” menu, reset both “Oil Control System” and “Oil and Filter” after changing the engine oil.

Tire:

This indicator appears when the user set distance comes for replacing tires. You can set or reset the distance for replacing tires.

 **WARNING**

The tire replacement indicator is not a substitute for regular tire checks, including tire pressure checks. (See “Changing wheels and tires” (P.8-38).) Many factors including tire inflation, alignment, driving habits and road conditions affect tire wear and when tires should be replaced. Setting the tire replacement indicator for a certain driving distance

does not mean your tires will last that long. Use the tire replacement indicator as a guide only and always perform regular tire checks. Failure to perform regular tire checks, including tire pressure checks could result in tire failure. Serious vehicle damage could occur and may lead to a collision, which could result in serious personal injury or death.

Other:

This indicator appears when the user set distance comes for checking or replacing maintenance items other than the engine oil, oil filter and tires. Other maintenance items can include such things as air filter or tire rotation. You can set or reset the distance for checking or replacing the items.

Customize Display

The display settings allows user to choose from the various meter selections.

The display settings can be changed using the scroll dial ①.

Main Menu Selection:

Displays available screens that can be shown in the vehicle information display.

Route Guidance (if so equipped):

To change the setting, use the scroll dial ① to select and push it.

- Alerts

The "Alerts" allows user to turn the Navigation Settings alerts on or off.

Transition (Cruise) (if so equipped):

The "Transition (Cruise)" allows user to turn the cruise screen transition on or off.

Welcome Effect:

The "Welcome Effect" displays the available welcome effect settings.

- Gauges (if so equipped)
- Animation

Operation guidance:

The "Operation guidance" displays the available operation guidance settings.

- Lights

- Wiper
 - Front
 - Rear
- Seat Memory (if so equipped)
- Cruise Control (if so equipped)

Unit/Language

The units that are shown in the vehicle information display can be changed:

- Mileage/Fuel
- Tire Pressure
- Temperature
- Language

Use the scroll dial ① to select and change the units of the vehicle information display.

Mileage/Fuel:

The unit for the mileage that is shown in the vehicle information display can be changed.

- miles, MPG
- km, km/l
- km, l/100km

Use the scroll dial ① to select and change the unit.

Tire Pressure:

The unit for tire pressures that is shown in the vehicle information display can be changed to:

- psi
- kPa
- bar
- kgf/cm²

(See "TPMS Setting" (P.2-27).)

When the tire pressure unit is changed, the unit for the turbo charger boost pressure gauge (if so equipped) is also changed. (See "Variable Compression Turbo" (P.2-12).)

Temperature:

The temperature that is shown in the vehicle information display can be changed from:

- °C
- °F

Use the scroll dial ① to toggle choices.

Language:

The language of the vehicle information display can be changed.

Use the scroll dial ① to select and change the language of the vehicle information display.

















Key-Linked Settings (if so equipped)

The Key-Linked Settings can be turned ON/OFF using the scroll dial ①. It will display the key synchronized and in use for this vehicle.

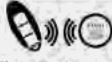











Factory Reset

The settings in the vehicle information display can be reset back to the factory default. To reset the vehicle information display:



1. Select "Factory Reset" using the scroll dial ① and push it.
2. Select "Yes" to return all settings back to default by pushing the scroll dial ①.

 BRAKE START STOP Push brake and start switch to drive	1	 Low Fuel	8	CVT CVT hot Power reduced	15	AWD AWD High Temp. Stop Vehicle	22	Headlight System Error See Owner's Manual	28
 No Key Detected	2	 Low Washer Fluid	9	CVT CVT Malfunction Stop safely	16	AWD Tire Size Incorrect See Owner's Manual	23	 Time for a break?	29
 Shift to Park	3	 Check position of shift lever	10	 When parked, apply parking brake	17	Shipping Mode On Push Storage Fuse	24	Chassis Control System Error See Owner's Manual	30
 Key Battery Low	4	REAR 	11	 Power will turn off to save the battery	18	Power will turn off to save the battery	25	Rear Door Alert is activated Disable Alert Dismiss Message	31
 Place the key near the start switch	5	 kPa 0 Tire Pressure Low Add Air 0	12	 Power turned off to save the battery	19	Power turned off to save the battery	26	Check Rear Seat for All Articles	32
 Key System Error See Owner's Manual	6	 Shift to P range	13	 AWD AWD Error See Owner's Manual	20	 Reminder Turn OFF Headlights	27		
Release Parking Brake	7	CVT CVT Malfunction Service now	14		21				

WAC0315X

	33	Unavailable High Cabin Temperature	41	Press Brake Pedal	48		56	AUTO HOLD	62
	34	Currently not available	42	Not Available Poor Road Conditions	49		57	Steep Slope Apply foot brake	62
	35	Forward Driving Aids temporarily disabled Front Sensor blocked See Owner's Manual	43	Not Available Seat Belt Not Fastened	50				63
	36	Unavailable Side Radar Obstruction	44	Not Available Bad Weather	51	Parking Sensor Error See Owner's Manual	58	Take a Break?	63
	37		45	Not Available Front Camera Obstructed	52	Press brake pedal to prevent rolling	59		64
Malfunction	38		46	Steering Assist Not Available Cannot Detect Lane	53	AUTO HOLD Press brake to operate switch	60	Driver Attention Alert Malfunction	64
Malfunction See Owner's Manual	39		47	Not Available Parking Brake On	54		59	To Exit Vehicle in Neutral: Engine ON, Brake ON Push P, shift into N twice	65
Not Available System Malfunction	40		47		55	AUTO HOLD	60	Neutral Hold Mode has been activated. To exit this mode, please shift to a different gear.	66
			47				61	Neutral Hold Mode was not activated.	67
						Caution Steep slope	61		

WAC0659X

 Low Oil Level	68
 Sensor Fault See Owner's Manual	69
 Service due in --- miles	70
CVT Stop the vehicle	71
CVT Service CVT Power reduced	72

WAC0655X

VEHICLE INFORMATION DISPLAY WARNINGS AND INDICATORS

The displayed images may differ depending on the model.

1. Engine start operation indicator

This indicator appears when the shift position is in the P (Park) position.

This indicator means that the engine will start by pushing the ignition switch with the brake pedal depressed. You can start the engine directly in any position of the ignition switch.

2. No Key Detected warning

This warning appears when the door is closed with the Intelligent Key left outside the vehicle and the engine is running. Make sure that the Intelligent Key is inside the vehicle.

See "Intelligent Key system" (P.3-7) for more details.

3. Shift to Park warning (if so equipped)

This warning appears when the door is opened while the shift position is other than P (Park).

If this warning appears, push the park button to engage the P (Park) position.

An inside warning chime will also sound.

(See "Intelligent Key system" (P.3-7).)

4. Key Battery Low warning

This warning appears when the Intelligent Key battery is running out of power.

If this indicator appears, replace the battery with a new one. See "Intelligent Key battery replacement" (P.8-24).

5. Engine start operation for Intelligent Key system indicator

This indicator appears when the Intelligent Key battery is running out of power and when the Intelligent Key system and vehicle are not communicating normally.

If this indicator appears, touch the ignition switch with the Intelligent Key while depressing the brake pedal. (See "Intelligent Key battery discharge" (P.5-17).)

6. Key System Error: See Owner's Manual warning

This warning appears if there is a malfunction in the Intelligent Key system.

If this warning appears while the engine is stopped, the engine cannot be started. If this warning appears while the engine is running, the vehicle can be driven. However, it is recommended that you visit a NISSAN dealer for repair as soon as possible.

7. Release Parking Brake warning

This warning appears when the accelerator pedal is depressed when the electronic parking brake automatic release function cannot be used. Release the electronic parking brake manually.

8. Low Fuel warning

This warning appears when the fuel level in the fuel tank is getting low. Refuel as soon as it is convenient, preferably before the fuel gauge reaches 0 (Empty). There will be a small reserve of fuel in the tank when the fuel gauge needle reaches 0 (Empty).

9. Low Washer Fluid warning (if so equipped)

This warning appears when the window washer fluid is at a low level. Add window washer fluid as necessary. For additional information, refer to "Window washer fluid" (P.8-13).

10. Door/liftgate open warning

This warning appears if any of the doors and/or the liftgate are open or not closed securely. The vehicle icon indicates which door or the liftgate is open on the display.

11. Rear seat belt warning

This warning appears for 35 seconds after the ignition switch is placed in the ON position.

This warning shows the status of the three rear seat belts. When one of the rear seat belts is buckled, the corresponding rear seat belt indicator will appear gray. When one of the rear seat belts is buckled and becomes unbuckled, the corresponding rear seat belt indicator will appear in red. If this occurs while the vehicle speed exceeds 10 MPH (15 km/h), a buzzer will sound.

For precautions on seat belt usage, see "Seat belts" (P.1-15).

12. Tire Pressure Low — Add Air warning

This warning appears when the low tire pressure warning light in the meter illuminates and low tire pressure is detected. The warning appears each time the ignition switch is placed in the ON position as long as the low tire pressure warning light remains illuminated. If this warning appears, stop the vehicle and adjust the pressure to the recommended COLD tire pressure shown on the Tire and Loading Information label. (See "Low tire pressure warning light" (P.2-18) and "Tire Pressure Monitoring System (TPMS)" (P.5-

6).)

13. Shift to P range warning

This warning appears when the driver's door is opened while the shift lever is in any position other than P (Park).

If this warning appears, push the park button to engage the P (Park) position.

An inside warning chime will also sound. (See "Intelligent Key system" (P.3-7).)

14. CVT Malfunction Service now warning

This warning appears when there is a malfunction with the CVT system. If this warning appears, have the system checked. It is recommended that you visit a NISSAN dealer for this service.

15. CVT hot Power reduced warning

The CVT has a high fluid temperature protection mode. If the fluid temperature becomes too high (for example, climbing steep grades in high temperatures with heavy loads, such as when towing a trailer), engine power and, under some conditions, vehicle speed will be decreased automatically to reduce the chance of transmission damage. Vehicle speed can be controlled with the accelerator pedal, but the engine and vehicle speed may be reduced.

16. CVT Malfunction Stop safely warning

This warning appears when there is a malfunction with the CVT system. If this warning appears, stop the vehicle in a safe place. Have the system checked. It is recommended you visit a NISSAN dealer for this service.

17. Check position of shift lever warning

This warning appears if the system cannot detect the shift position. Make sure the vehicle is placed in a position properly. Have the system checked. It is recommended you contact a NISSAN dealer for this service.

18. When parked apply parking brake warning

This warning appears if a malfunction occurs in the electric shift control system. Contact a NISSAN dealer as soon as possible. When parking the vehicle, make sure that the parking brake is applied. If the parking brake is not applied, the ignition switch may not be turned off.

19. Continuously Variable Transmission (CVT) position indicator

This indicator shows the CVT shift position.

In the manual shift mode, when the transmission does not shift to the selected gear due to a transmission protection mode, the CVT position indicator will blink and a chime will sound.

See "Continuously Variable Transmission (CVT)" (P.5-19) for further details.

20. Drive Mode Selector indicator

When a driving mode is selected using the Drive Mode Selector, the selected mode indicator is displayed.

- OFF-ROAD (AWD models)
- SNOW (AWD models)
- STANDARD (2WD models)
- AUTO (AWD models)
- ECO
- SPORT

(See "Drive Mode Selector" (P.5-31).)

21. AWD Error: See Owner's Manual warning (if so equipped)

This warning appears when the All-Wheel Drive (AWD) system is not functioning properly while the engine is running. Reduce vehicle speed and have your vehicle checked as soon as possible. It is recommended that you visit a NISSAN dealer for this service. (See "Intelligent 4x4" (P.5-151).)

22. AWD High Temp. Stop vehicle warning (if so equipped)

This warning appears when the oil temperature of the powertrain parts increases due to the difference in rotation between the front and rear wheels is large (wheel slip), such as when driving on rough roads, driving through sand or mud, or freeing a stuck vehicle. If this warning is displayed, stop the vehicle with the engine idling, as soon as it is safe to do so. In these cases, the AWD changes to 2WD to protect the powertrain parts. Then if the warning turns off, you can continue AWD driving. (See "Intelligent 4x4" (P.5-151).)

23. Tire Size Incorrect: See Owner's Manual warning (if so equipped)

This warning may appear if there is a large difference between the diameters of front and rear wheels and tires. Pull off the road in a safe area, with the engine idling. Check that all the tire sizes, brand, construction and tread pattern are the same, that the tire pressures are correct and that the tires are not excessively worn. If you have any problems, change tires or adjust tire pressures correctly. Do not select the SNOW or OFF-ROAD mode with the Drive Mode Selector and do not drive fast. (See "Intelligent 4x4" (P.5-151).)

24. Shipping Mode On Push Storage Fuse warning (if so equipped)

This warning may appear if the extended storage switch is not pushed in. When this warning appears, push in the extended storage switch to turn off the warning. (See "Extended storage switch" (P.8-24).)

25. Power will turn off to save the battery warning

Under the specific conditions, this warning may appear after the ignition switch is in the ON position for a certain period of time.

26. Power turned off to save the battery warning

Under the specific conditions, this warning may appear after the ignition switch is automatically turned OFF to save the battery.

27. Reminder Turn OFF Headlights warning

This warning appears when the driver side door is opened with the headlight switch is left ON and the ignition switch is placed in the OFF position. Place the headlight switch in OFF (if so equipped) or AUTO position. For additional information, (See "Headlight and turn signal switch" (P.2-58).)

28. Headlight System Error: See Owner's Manual warning

This warning appears if the LED headlights are malfunctioning. Have the system checked. It is recommended that you visit a NISSAN dealer for this service.

29. Time for a break? indicator

This indicator appears when the set Timer Alert activates. You can set the time for up to 6 hours.

30. Chassis Control System Error: See Owner's Manual warning

This warning appears if the chassis control module detects a malfunction in the chassis control system. Have the system checked. It is recommended that you visit a NISSAN dealer for this service. (See "Chassis control" (P.5-160).)

31. Rear Door Alert is activated indicator

When the system is enabled, this message appears when the Rear Door Alert system is active and can remind the driver to check the rear seat.

- Using the steering switch, the driver can select "Dismiss Message" to clear the display for a period of time.
- Using the steering switch, the driver can select "Disable Alert" to disable the horn alert for the remainder of the current trip.

For additional information, see "Rear Door Alert" (P.2-68).



WARNING

Selecting "Dismiss Message" during a stop within a trip temporarily dismisses the message for that stop without turning the system off.

Alerts can be provided for other stops during the trip. Selecting “Disable Alert” turns off the Rear Door Alert system for the remainder of a trip and no audible alert will be provided.

NOTE:

This system is disabled until the driver enables it using the settings menu. See “Vehicle Settings” (P.2-28).

32. Check Rear Seat For all articles indicator

When the system is enabled, this message appears when the vehicle comes to a complete stop, the shift position is placed from the D (Drive) to P (Park), and the driver exits the vehicle. This message alerts the driver, after a period of time, to check for items in the rear seat after the audible alert has been provided.

NOTE:

This system is disabled until the driver enables it using the settings menu. See “Vehicle Settings” (P.2-28).

33. Lane Departure Warning (LDW)/Intelligent Lane Intervention (I-LI) indicator

This indicator appears when the Lane Departure Warning (LDW) and/or Intelligent Lane Intervention (I-LI) (if so equipped) systems are engaged.

(See “Lane Departure Warning (LDW)” (P.5-47) or “Intelligent Lane Intervention (I-LI)” (P.5-52).)

34. Blind Spot Warning (BSW)/Intelligent Blind Spot Intervention (I-BSI) indicator

This indicator appears when the Blind Spot Warning (BSW) and/or Intelligent Blind Spot Intervention (I-BSI) (if so equipped) systems are engaged.

(See “Blind Spot Warning (BSW)” (P.5-58) or “Intelligent Blind Spot Intervention (I-BSI)” (P.5-66).)

35. Vehicle ahead detection indicator

This indicator shows the status of the following systems:

- Automatic Emergency Braking (AEB) with Pedestrian Detection
- Intelligent Forward Collision Warning (I-FCW)

(See “Automatic Emergency Braking (AEB) with Pedestrian Detection system” (P.5-122) or “Intelligent Forward Collision Warning (I-FCW)” (P.5-132).)

36. Cruise indicator (if so equipped)

Models without Intelligent Cruise Control (ICC) system:

This indicator shows the cruise control system status. The status is shown by the color.

(See “Cruise control” (P.5-83).)

Models with Intelligent Cruise Control (ICC) system:

This indicator shows the conventional (fixed speed) cruise control mode status. The status is shown by the color.

(See “Conventional (fixed speed) cruise control mode” (P.5-119).)

37. Speed control status/set distance/lane marker indicator (if so equipped)

This indicator shows the status of the Intelligent Cruise Control (ICC) system and the detection of the lane markers. The status is shown by the color and shape. (See “ProPILOT Assist” (P.5-85).)

38. Malfunction warning

This warning appears when the following systems malfunction.

- Rear Cross Traffic Alert (RCTA)
- Automatic Emergency Braking (AEB) with Pedestrian Detection
- Intelligent Forward Collision Warning (I-FCW)

(See "Rear Cross Traffic Alert (RCTA)" (P.5-77), "Automatic Emergency Braking (AEB) with Pedestrian Detection system" (P.5-122) or "Intelligent Forward Collision Warning (I-FCW)" (P.5-132).)

39. Malfunction See Owner's Manual warning (if so equipped)

This warning appears when the following systems malfunction.

- Traffic Sign Recognition (TSR) (if so equipped)
- Rear Automatic Braking (RAB)

(See "Traffic Sign Recognition (TSR)" (P.5-44) or "Rear Automatic Braking (RAB)" (P.5-143).)

40. Not Available System Malfunction warning

This warning appears when the following systems malfunction.

- Lane Departure Warning (LDW)
- Intelligent Lane Intervention (I-LI) (if so equipped)
- Blind Spot Warning (BSW)
- Intelligent Blind Spot Intervention (I-BSI) (if so equipped)
- ProPILOT Assist (if so equipped)

(See "Lane Departure Warning (LDW)" (P.5-47), "Intelligent Lane Intervention (I-LI)" (P.5-52), "Blind Spot Warning (BSW)" (P.5-58) or "ProPILOT Assist" (P.5-85).)

41. Unavailable High Cabin Temperature warning (if so equipped)

This warning appears if the interior temperature of the vehicle has reached such a high temperature that the sensor for the following systems can no longer function reliably.

- Lane Departure Warning (LDW)
- Intelligent Lane Intervention (I-LI) (if so equipped)
- Automatic Emergency Braking (AEB) with Pedestrian Detection
- Intelligent Blind Spot Intervention (I-BSI) (if so equipped)

- Traffic Sign Recognition (TSR) (if so equipped)

Once the interior temperature has reached normal levels, the warning should disappear.

If the warning continues to display, have the system checked. It is recommended that you visit a NISSAN dealer for this service.

For additional information, refer to "Lane Departure Warning (LDW)" (P.5-47), "Intelligent Lane Intervention (I-LI)" (P.5-115), "Automatic Emergency Braking (AEB) with Pedestrian Detection system" (P.5-122), "Intelligent Blind Spot Intervention (I-BSI)" (P.5-66) or "Traffic Sign Recognition (TSR)" (P.5-44).

42. Currently not available warning

This warning appears when the Intelligent Lane Intervention (I-LI) (if so equipped), Intelligent Blind Spot Intervention (I-BSI) (if so equipped) or the Intelligent Cruise Control (ICC) system (if so equipped) becomes unavailable in the following conditions:

- The Vehicle Dynamic Control (VDC) system is turned off
- The SNOW mode or the OFF-ROAD mode is selected (AWD models).

For additional information, refer to "Intelligent Lane Intervention (I-LI)" (P.5-52),

"Intelligent Blind Spot Intervention (I-BSI)" (P.5-66) or "Intelligent Cruise Control (ICC)" (P.5-98).

43. Forward Driving Aids temporarily disabled Front Sensor blocked warning

If the front radar sensor area on the front of the vehicle is covered with dirt or obstructed, making it impossible to detect a vehicle ahead, the following system is automatically turned off.

- Intelligent Cruise Control (ICC) (on ProPILOT Assist system) (if so equipped)
- Automatic Emergency Braking (AEB) with Pedestrian Detection
- Intelligent Forward Collision Warning (I-FCW)

If the warning message appears, park the vehicle in a safe location and turn the engine off.

Check to see if the sensor area is blocked. If the sensor area is blocked, remove the blocking material. Restart the engine. If the warning message continues to appear, have the system checked. It is recommended that you visit a NISSAN dealer for this service.

For more details, see "ProPILOT Assist" (P.5-85), "Automatic Emergency Braking

(AEB) with Pedestrian Detection system" (P.5-122) or "Intelligent Forward Collision Warning (I-FCW)" (P.5-132).

44. Unavailable Side Radar Obstruction warning

This warning appears when the following systems become unavailable because a radar blockage is detected.

- Blind Spot Warning (BSW)
 - Intelligent Blind Spot Intervention (I-BSI) (if so equipped)
 - Rear Cross Traffic Alert (RCTA)
- (See "Blind Spot Warning (BSW)" (P.5-58), "Intelligent Blind Spot Intervention (I-BSI)" (P.5-66) or "Rear Cross Traffic Alert (RCTA)" (P.5-77).)

45. I-LI ON indicator/I-BSI ON indicator/ProPILOT Assist status indicator (if so equipped)

This indicator appears when the following systems are turned on:

- Intelligent Lane Intervention (I-LI) (if so equipped)
- Intelligent Blind Spot Intervention (I-BSI) (if so equipped)
- ProPILOT Assist (if so equipped)

See "Intelligent Lane Intervention (I-LI)" (P.5-52), "Intelligent Blind Spot Intervention (I-BSI)" (P.5-66) or "ProPILOT Assist"

(P.5-85).

46. Steering Assist indicator (if so equipped)

This indicator appears when the Steering Assist system is engaged.

See "ProPILOT Assist" (P.5-85).

47. Hands on detection warning (if so equipped)

This warning may appear when the Steering Assist system is engaged and the following condition(s) occur:

- When not holding the steering wheel
- When there is no steering wheel operation

Hold on the steering wheel immediately. When the steering operation is detected, the warning turns off and the Steering Assist function is automatically restored. For additional information, refer to "ProPILOT Assist" (P.5-85).

48. Press Brake Pedal indicator (if so equipped)

This message may appear when the Intelligent Cruise Control (ICC) system is engaged and the following condition occurs:

- While the vehicle is stopped by the ICC system, the driver's door is opened but

the electronic parking brake was not activated.

Step on the brake pedal immediately.

49. Not Available Poor Road Conditions warning (if so equipped)

This warning appears when the following systems become unavailable because the road is slippery.

- Intelligent Lane Intervention (I-LI) (if so equipped)
- Intelligent Blind Spot Intervention (I-BSI) (if so equipped)
- Intelligent Cruise Control (ICC) (if so equipped)

(See "Intelligent Lane Intervention (I-LI)" (P.5-52), "Intelligent Blind Spot Intervention (I-BSI)" (P.5-66) or "Intelligent Cruise Control (ICC)" (P.5-98).)

50. Not Available Seat Belt Not Fastened indicator (if so equipped)

This message may appear when the Intelligent Cruise Control (ICC) system is engaged.

Under the following condition, the ICC system is automatically canceled:

- When the driver's seat belt is not fastened.

The ICC system cannot be used when the driver's seat belt is not fastened.

51. Not Available Bad Weather indicator (if so equipped)

This message may appear when the Steering Assist system is engaged.

Under the following conditions, the Steering Assist system is automatically canceled:

- When the wiper (HI) operates.
- When lane markers in the traveling lane cannot be correctly detected for a period of time due to such items as a snow rut, reflection of light on a rainy day or several unclear lane markers are present.

If you want to use the Steering Assist system again, cancel the ProPILOT Assist system and set it again when lane markers are clearly visible.

52. Not Available Front Camera Obstructed indicator (if so equipped)

This message may appear when the Steering Assist system is engaged.

Under the following conditions, the Steering Assist system is automatically canceled:

- The camera area of the windshield is fogged up or covered with dirt, water, drops, ice, snow, etc.

- Strong light, such as sunlight or high beams from oncoming vehicles, enter the front camera

53. Steering Assist Not Available Cannot Detect Lane indicator (if so equipped)

This indicator may appear when the Steering Assist system is engaged. The Steering Assist system is automatically canceled when the lane markers in the traveling lane cannot be correctly detected for a period of time due to such items as a snow rut, reflection of light on a rainy day or several unclear lane markers are present.

If you want to use the Steering Assist system again, cancel the ProPILOT system and set it again when lane markers are clearly visible.

54. Not Available Parking Brake On indicator (if so equipped)

This message may appear when the Intelligent Cruise Control (ICC) system is engaged.

Under the following condition, the ICC system is automatically canceled:

- The electronic parking brake is applied.

The above system cannot be used when

the electronic parking brake is activated.

55. Automatic Emergency Braking (AEB) emergency warning indicator

This warning indicator appears along with an audible warning, when the Automatic Emergency Braking (AEB) with Pedestrian Detection system detects the possibility of a forward collision.

See "Automatic Emergency Braking (AEB) with Pedestrian Detection system" (P.5-122).

56. Rear Automatic Braking (RAB) system warning indicator

This warning indicator appears to indicate the status of the Rear Automatic Braking (RAB) system.

See "Rear Automatic Braking (RAB)" (P.5-143).

57. Sonar system/Rear Sonar System (RSS) indicator

This indicator appears to indicate the status of the sonar system (if so equipped) or the Rear Sonar System (RSS) (if so equipped).

See "Sonar system" (P.5-162) or "Rear Sonar System (RSS)" (P.5-168).

58. Parking Sensor Error warning

This warning appears when there is a malfunction with the sonar system (if so equipped) or the Rear Sonar System (RSS) (if so equipped). (See "Sonar system" (P.5-162) or "Rear Sonar System (RSS)" (P.5-168).)

59. Press brake pedal to prevent rolling warning

This warning appears in the following situations:

- The driver tries to release the electronic parking brake manually without depressing the brake pedal.
- The vehicle is stopped on a steep hill and there is a possibility of moving backward, even if the electronic parking brake is applied.
- This warning appears and a chime sounds if the vehicle moves while the automatic brake hold function is activated. Apply the foot brake to stop the vehicle moving.

60. Press brake to operate switch indicator

This indicator appears if the automatic brake hold switch is pushed without depressing the brake pedal while the automatic brake hold function is activated. Depress the brake pedal and push

the switch to deactivate the automatic brake hold function. (See "Automatic brake hold" (P.5-28).)

61. Caution Steep slope indicator

This indicator appears and a chime sounds when the automatic brake hold function is activated while the vehicle is on a steep hill. Apply the foot brake to stop the vehicle moving. (See "Automatic brake hold" (P.5-28).)

62. Steep Slope Apply foot brake indicator

This indicator appears and a chime sounds if "Caution Steep slope indicator" has appeared over about 3 minutes. Then, the parking brake will automatically be applied and the brake force of the automatic brake hold will be released, and vehicle may move or roll away unexpectedly. Apply the foot brake to stop the vehicle moving. (See "Automatic brake hold" (P.5-28).)

63. Take a Break? indicator

This indicator appears when the Intelligent Driver Alertness (I-DA) system detect that the driver attention is decreasing. (See "Intelligent Driver Alertness (I-DA)" (P.5-141).)

64. Intelligent Driver Alertness (I-DA) malfunction warning

This warning appears when the Intelligent Driver Alertness (I-DA) system malfunctions. (See "Intelligent Driver Alertness (I-DA)" (P.5-141).)

65. Neutral Hold Mode guidance indicator (if so equipped)

This indicator appears when the ignition switch is placed in the OFF position while the shift position is in the N (Neutral) position (Neutral hold mode is available). (See "Neutral hold mode function" (P.5-22).)

66. Neutral Hold Mode activated indicator (if so equipped)

This indicator appears when the Neutral hold mode is activated. To exit the Neutral hold mode, place the vehicle in other than N (Neutral) position. (See "Neutral hold mode function" (P.5-22).)

67. Neutral Hold Mode was not activated indicator (if so equipped)

This indicator appears when the Neutral hold mode is unavailable. To activate the Neutral hold mode, wait for a while without shifting and then perform the operations again. (See "Neutral hold mode function" (P.5-22).)

68. Low Oil Level warning (if so equipped)

This warning appears when the engine oil level is low. Warm up the engine on a level surface. After at least 10 minutes have passed since the engine was stopped, use the engine oil dipstick to check the oil level. (See "Engine oil" (P.8-8).) If the oil level is low, add the engine oil.

If the warning appears again before reaching the oil change interval shown in the "9. Maintenance and schedules" section, check the oil level. When the warning appears and the oil level is low, have the vehicle checked. It is recommended that you visit a NISSAN dealer for this service.

NOTE:

If the vehicle is not on a level surface, accurate measurement of the oil level may not be possible. If "Low Oil Level" warning message appears, but the level shown by the oil dipstick is normal, move the vehicle to a level surface and stop the engine. After at least 10 minutes have passed, open the driver's door and place the ignition switch in the ON position. If the "Low Oil Level" warning message appears again, add the engine oil or change the engine oil, according to the instructions described

above.

69. Sensor Fault See Owner's Manual warning (if so equipped)

This warning appears when the engine oil level sensor may be malfunctioning. It is recommended you contact a NISSAN dealer immediately.

70. Engine Oil Service due in - - - miles

This distance to oil change is displayed if the distance to oil change is less than 62 miles (100 km).

71. Stop the vehicle warning (if so equipped)

This warning appears when the CVT system judges the vehicle is reversed on an uphill road with the shift position in D (Drive), or moved forward on a downhill road with the shift position in R (Reverse). The engine may stall, so stop the vehicle movement by depressing the brake pedal.

72. Service CVT Power reduced warning (if so equipped)

This warning appears when the CVT power is reduced. If this warning appears, have the system checked. It is recommended that you visit a NISSAN dealer for this service.

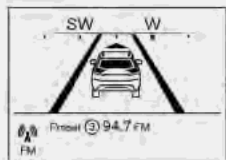

1



5

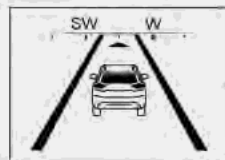

9



13

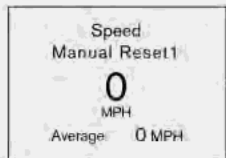

2

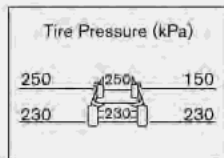

6



10

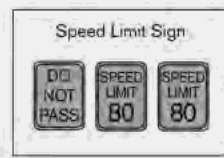

14

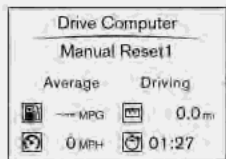

3

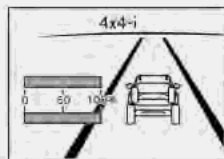

7



11

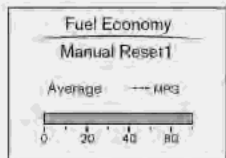

4

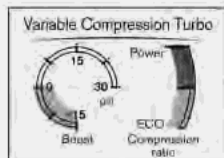

8

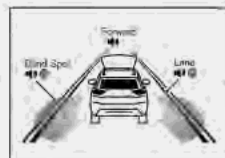

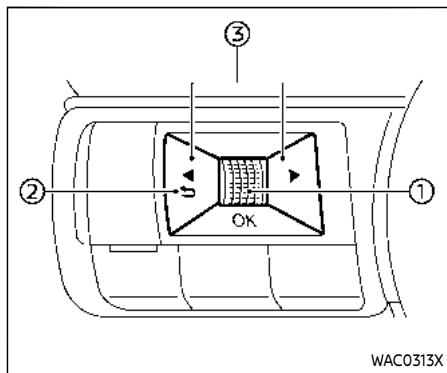

12

WAC0660X



TRIP COMPUTER

Switches for the trip computer are located on the left side of the steering wheel.

- ① Scroll dial - navigate through the items and change or select an item in vehicle information display
this scroll dial allows up/down navigation and push to select
- ②  - go back to the previous menu
- ③  - change from one display screen to the next (i.e. trip, Fuel economy)

The displayed images may differ depending on the model.

1. Home

The Home mode shows the following information.

- Vehicle speed
- Navigation (if so equipped)
- Audio

2. Vehicle Speed (if so equipped)

The Vehicle Speed mode shows the current vehicle speed and the average vehicle speed since the last reset. The Vehicle Speed mode have three modes of operation. You can switch between Manual Reset1, Manual Reset2 or Auto Refuel by pushing the scroll dial ①.

Manual Reset1 and Manual Reset2 can be reset manually by using the scroll dial ①.

Auto Refuel will be reset automatically each time when refueling.

3. Drive Computer

Average fuel consumption:

The average fuel consumption shows the average fuel consumption since the last reset.

Average speed:

The average speed shows the average vehicle speed since the last reset.

Trip odometer:

The trip odometer shows the total distance the vehicle has been driven since the last reset.

Elapsed time:

The elapsed time shows the time since the last reset.

The Drive Computer mode have three modes of operation. You can switch between Manual Reset1, Manual Reset2 or Auto Refuel by pushing the scroll dial ①.

Manual Reset1 and Manual Reset2 can be reset manually by using the scroll dial ①.

Auto Refuel will be reset automatically each time when refueling.

4. Fuel Economy display

Current fuel consumption:

The Fuel economy display mode shows the current fuel consumption.

Average fuel consumption:

The Fuel economy display mode shows the average fuel consumption since the last reset.

The Fuel economy display mode have three modes of operation. You can switch between Manual Reset1, Manual Reset2 or Auto Refuel by pushing the scroll dial ①.

Manual Reset1 and Manual Reset2 can be reset manually by using the scroll dial ①. Auto Refuel will be reset automatically each time when refueling.

5. ECO Pedal Guide

When the ECO mode is selected, you can view the ECO Pedal Guide function for improving fuel economy.

The ECO Pedal Guide mode have three modes of operation. You can switch between Manual Reset1, Manual Reset2 or Auto Refuel by pushing the scroll dial ①.

Manual Reset1 and Manual Reset2 can be reset manually by using the scroll dial ①.

Auto Refuel will be reset automatically each time when refueling.

(See "ECO Pedal Guide function" (P.5-33).)

6. Tire Pressures

The tire pressure mode shows the pressure of all four tires while the vehicle is driven.

With the "Tire Pres ECO advice" function ON, when the tire pressure is getting low, "Check Tire Pressures for Best Fuel Economy" appears. (See "ECO Mode Setting" (P.2-26) and "Tire Pres ECO advice" (P.5-33).)

When the Tire Pressure Low — Add Air

warning appears, the display can be switched to the tire pressure mode by pushing the scroll dial ① to reveal additional details on the displayed warning.

7. Intelligent 4x4 torque distribution display (if so equipped)

When the Intelligent 4x4 torque distribution display is selected, you can view the distribution ratio of the transmission torque to the front and rear wheels during driving.

8. Variable Compression Turbo (if so equipped)

Variable Compression Turbo mode shows the status of Variable Compression Turbo information. (See "Variable Compression Turbo" (P.2-12).)

9. Compass (if so equipped)

This display indicates the heading direction of the vehicle.

10. Navigation (if so equipped)

When the route guidance is set in the navigation system, this item shows the navigation route information.

11. Audio

The audio mode shows the status of audio information.

12. Driver Assistance

The Driver Assistance mode shows the operating condition for the following systems.

- Forward:
 - Automatic Emergency Braking (AEB) with Pedestrian Detection system
 - Intelligent Forward Collision Warning (I-FCW)
- Lane:
 - Lane Departure Warning (LDW)
 - Intelligent Lane Intervention (I-LI) (if so equipped)
- Blind Spot:
 - Blind Spot Warning (BSW)
 - Intelligent Blind Spot Intervention (I-BSI) (if so equipped)

For more details, see "Automatic Emergency Braking (AEB) with Pedestrian Detection system" (P.5-122), "Lane Departure Warning (LDW)" (P.5-47), "Intelligent Lane Intervention (I-LI)" (P.5-52), "Blind Spot Warning (BSW)" (P.5-58) or "Intelligent Blind Spot Intervention (I-BSI)" (P.5-66).

13. ProPILOT Assist (if so equipped)

The ProPILOT Assist mode shows the operating conditions for the following systems:

- Intelligent Cruise Control (ICC)
- Steering Assist

The display will also be shown when the ProPILOT Assist is turned on. For additional information, see "ProPILOT Assist" (P.5-85).

14. Traffic Sign Recognition (if so equipped)

The Traffic Sign Recognition (TSR) system provides the driver with information about the most recently detected speed limit. See "Traffic Sign Recognition (TSR)" (P.5-44) for more details.

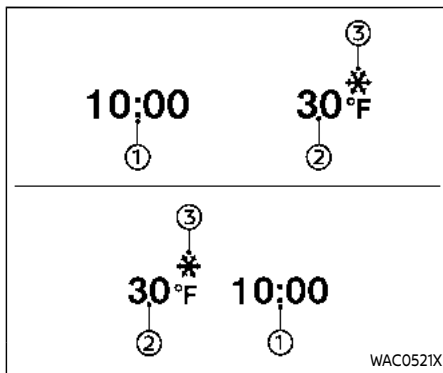

CLOCK AND OUTSIDE AIR TEMPERATURE

The clock ① and outside air temperature ② are displayed on the upper side of the vehicle information display.

Clock

For clock adjustment, see "Clock" (P.2-27) or the separate NissanConnect® Owner's Manual (if so equipped).

Outside air temperature (°F or °C)

The outside air temperature is displayed in °F or °C in the range of -40 to 140°F (-40 to 60°C).

The outside air temperature mode includes a low temperature warning feature. If the outside air temperature is below 27°F (-3°C), the indicator ③ is displayed.

The outside temperature sensor is located in front of the radiator. The sensor may be affected by road or engine heat, wind directions and other driving conditions. The display may differ from the actual outside temperature or the temperature displayed on various signs, billboards or media information.

HEAD UP DISPLAY (HUD) (if so equipped)

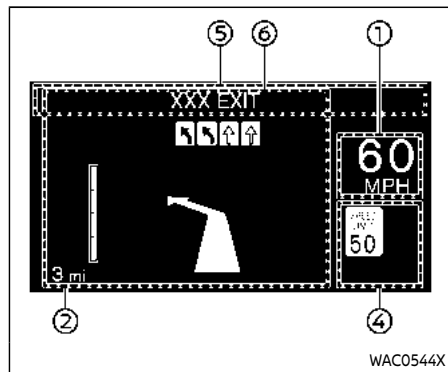
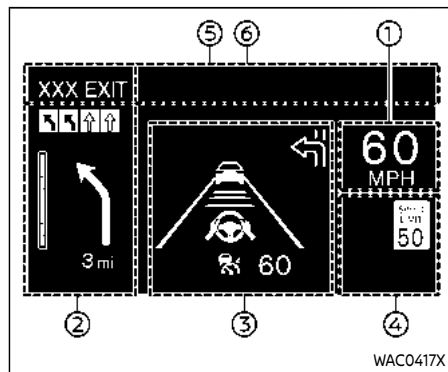

WARNING

- Failure to properly adjust the brightness and position of the displayed image may interfere with the driver's ability to see through the windshield, which could cause an accident leading to severe injury or death.
- Do not use the Head Up Display (HUD) for extended periods of time as that can cause you to not see other vehicles, pedestrians or objects, which could cause an accident leading to severe injury or death.

The Head Up Display (HUD) can display one or more of the following features (if so equipped):

- ① Vehicle speed
- ② Navigation
- ③ Driving Assist
- ④ Traffic Sign
- ⑤ Audio
- ⑥ TEL/SMS

NOTE:

- Do not place any type of liquid on or near the projector. Doing so may cause malfunction of the equip-

ment.

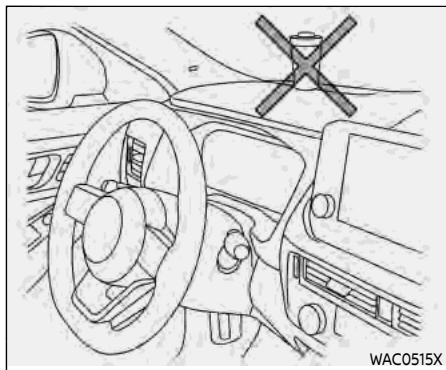

- Do not touch any internal parts of the projector. Doing so may cause malfunction of the equipment.
- To prevent scratches to the projector glass, do not place any sharp objects on or near the projector opening.
- Do not place any objects on the instrument panel which may obstruct the display of the HUD.
- For cleaning, use a dry soft cloth. If dirt, etc. cannot be removed, use a clean, soft cloth dampened with water and then use a clean, dry soft cloth. Never use a rough cloth, alcohol, benzine, thinner or any kind of solvent or paper towel with a che-

mical cleaning agent. They will scratch or cause discoloration to the projector lens.

- Do not spray any liquid such as water on the projector lens. Spraying liquid may cause the system to malfunction.

NOTE:

- If you wear polarized sunglasses, the display may be difficult to see. Increase the brightness of the HUD in the vehicle information display or remove your sunglasses.
- Depending on weather conditions (rain, snow, sunlight, etc.), the display may be difficult to see.
- If the displayed image appears distorted, it is recommended you have the system checked by a NISSAN dealer.
- The HUD has a special windshield to allow the image to be displayed clearly. If your windshield needs replacing, it is recommended that you have the work completed by a NISSAN dealer.

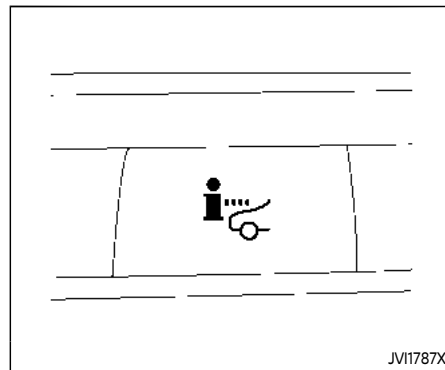

HOW TO USE THE HUD

To turn the HUD on, push the HUD switch. To turn the HUD off, push the switch again.

If the HUD is turned off, it will remain off even if the vehicle is restarted.

The following settings can be changed in the vehicle information display:

- Brightness
- Height
- Rotation
- Contents selection
 - Navigation (if so equipped)

- Driving Assist
- Speed Limit Sign
- Audio
- TEL/SMS

- Reset

NOTE:

Emergency information may be displayed even if the HUD is turned off.

This product includes the following software.

- (1) Panasonic Corporation or software developed for Panasonic Corporation
- (2) Third-party software licensed to Panasonic Corporation
- (3) Open source software

Regarding (3) Open source software, it includes open source software (OSS), including various software to which license information applies.

Refer to the license web site at: <http://car.panasonic.jp/oss/i02ln39>

Display brightness

The brightness of the display may be controlled in the vehicle information display. The brightness will also be adjusted automatically according to the exterior ambient lighting brightness.

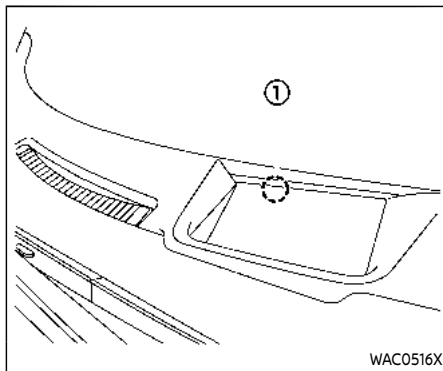

NOTE:

- **The HUD has a built-in sensor ① that controls the brightness of the displayed image. If you block the sensor with an object, the display will darken, making it difficult to see. Make sure the sensor is clear of obstructions.**
- **Do not apply strong light to the sensor. Doing so may cause a malfunction.**

DRIVER ASSISTANCE/NAVIGATION/TRAFFIC SIGN/AUDIO/TEL/SMS LINKING

The HUD will display Driver Assistance and navigation information.

The Driver Assistance display will show warning situations for the following systems:

- Automatic Emergency Braking (AEB) with Pedestrian Detection
- Intelligent Forward Collision Warning (I-FCW)
- Lane Departure Warning (LDW)
- Intelligent Lane Intervention (I-LI)
- Hands-free warning (for vehicles with ProPILOT Assist) (if so equipped)

The Navigation System linking display will show the following items:

- Intersection names
- Arrows indicating turning direction
- Distance to the next intersection
- Recommended lane indicator

The Traffic Signs Recognition (TSR) system linking display will show the following items:

- Speed Limit Sign
- No Entry Sign

The Audio System linking display will show the following items:

SECURITY SYSTEMS

- Songs
- Radio stations

The TEL/SMS linking display will show the following item:

- Caller's name or phone number

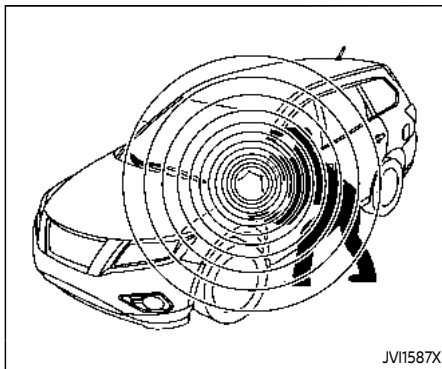

Your vehicle has two types of security systems, as follows:

- Vehicle security system (if so equipped)
 - NISSAN Vehicle Immobilizer System
- VEHICLE SECURITY SYSTEM (if so equipped)**

The vehicle security system provides visual and audio alarm signals if someone opens the doors, hood and liftgate when the system is armed. It is not, however, a motion detection type system that activates when a vehicle is moved or when a vibration occurs.

The system helps deter vehicle theft but cannot prevent it, nor can it prevent the

theft of interior or exterior vehicle components in all situations. Always secure your vehicle even if parking for a brief period. Never leave your keys in the vehicle, and always lock it when unattended. Be aware of your surroundings, and park in secure, well-lit areas whenever possible.

Many devices offering additional protection, such as component locks, identification markers, and tracking systems, are available at auto supply stores and specialty shops. Your NISSAN dealer may also offer such equipment. Check with your insurance company to see if you may be eligible for discounts for various theft protection features.

How to arm the vehicle security system

1. Close all windows. **The system can be armed even if the windows are open.**
2. Remove the keys from the vehicle.
3. Close all doors, hood and liftgate. Lock all doors. The doors can be locked with Intelligent Key, door handle request switch (if so equipped).

Even when the driver and/or passengers are in the vehicle, the system will activate with all the doors, hood and liftgate locked with the ignition switch placed in the OFF position. When pla-

cing the ignition switch in the ON position, the system will be released.

Vehicle security system activation

The vehicle security system will give the following alarm:

- The headlights or the hazard indicator lights blink and the horn sounds intermittently.
- The alarm automatically turns off after approximately 30 seconds. However, the alarm reactivates if the vehicle is tampered with again.

The alarm is activated by:

- opening any doors, the hood or lift-gate without using Intelligent Key (even if the door is unlocked by releasing the door inside lock knob).

How to stop an activated alarm

The alarm stops by pushing the UNLOCK  button on the Intelligent Key, pushing the request switch (if so equipped) in range of the door handle or placing the ignition switch in the ON position.

NISSAN VEHICLE IMMOBILIZER SYSTEM

The NISSAN Vehicle Immobilizer System will not allow the engine to start without the use of the registered key.

If the engine does not start using the registered Intelligent Key, it may be due to interference caused by:

- Another Intelligent Key.
- Automated toll road device.
- Automated payment device.
- Other devices that transmit similar signals.

Start the engine using the following procedure:

1. Remove any items that may be causing the interference away from the Intelligent Key.
2. Start the engine again.

If this procedure allows the engine to start, NISSAN recommends placing the registered Intelligent Key separate from other devices to avoid interference.

Statement related to section 15 of FCC rules for NISSAN Vehicle Immobilizer System (CONT ASSY-SMART KEYLESS)

FCC Notice:

For USA:

FCC ID : KR5HFM401

This device complies with Part 15 of the FCC Rules. Operation is subject to the following two conditions: (1) This device may not cause harmful interference, and (2) this device must accept any interference received, including interference that may cause undesired operation.

Note: Changes or modifications not expressly approved by the party responsible for compliance could void the user's authority to operate the equipment.

For Canada:

IC ID : 7812D-HFM401

This device complies with Industry Canada licence-exempt RSS standard(s). Operation is subject to the following two conditions: (1) this device may not cause interference, and (2) this device must accept any interference, including interference that may cause undesired operation of the device.

WIPER AND WASHER SWITCH

WARNING

In freezing temperatures the washer solution may freeze on the windshield and obscure your vision which may lead to an accident. Warm windshield with the defroster before you wash the windshield.

CAUTION

- Do not operate the washer continuously for more than 30 seconds.
- Do not operate the washer if the reservoir tank is empty.
- Do not fill the window washer reservoir tank with washer fluid concentrates at full strength. Some methyl alcohol based washer fluid concentrates may permanently stain the grille if spilled while filling the window washer reservoir tank.
- Pre-mix washer fluid concentrates with water to the manufacturer's recommended levels before pouring the fluid into the window washer reservoir tank. Do

not use the window washer reservoir tank to mix the washer fluid concentrate and water.

If the windshield wiper operation is interrupted by snow or ice, the wiper may stop moving to protect its motor. If this occurs, turn the wiper switch to the OFF position and remove the snow or ice that is on and around the wiper arms. In approximately 1 minute, turn the switch on again to operate the wiper.

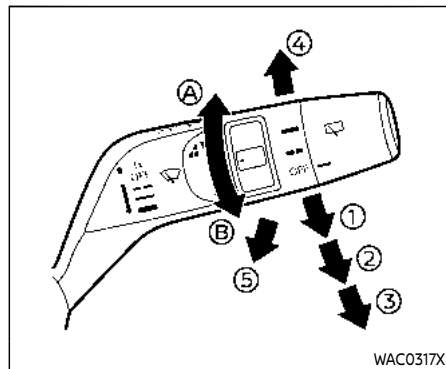

WINDSHIELD WIPER AND WASHER OPERATION

The windshield wiper and washer operates when the ignition switch is in the ON position.

Push the lever down to operate the wiper at the following speed:

- ① Intermittent — intermittent operation can be adjusted by turning the knob toward **A** (Faster) or **B** (Slower). Also, the intermittent operation speed varies in accordance with the vehicle speed. (For example, when the vehicle speed is high, the intermittent operation speed will be faster.)
- ② Low — continuous low speed operation

⑤ High — continuous high speed operation
Push the lever up ④ to have one sweep operation of the wiper.

Pull the lever toward you ⑤ to operate the washer. Then the wiper will also operate several times.

NOTE:

The Speed Dependent feature may be disabled. For additional information, refer to “Vehicle Settings” (P.2-28).



CAUTION

Do not operate the windshield wiper while the wiper arm is pulled up. The wiper arm may be damaged.

REAR WINDOW WIPER AND WASHER OPERATION



WARNING

In freezing temperatures the washer solution may freeze on the rear window glass and obscure your vision. Warm the rear window with the defroster before you wash the rear window.



CAUTION

- Do not operate the washer continuously for more than 30 seconds.
- Do not operate the washer if the reservoir tank is empty.
- Do not fill the window washer reservoir tank with washer fluid concentrates at full strength. Some methyl alcohol based washer fluid concentrates may permanently stain the grille if spilled while filling the window washer reservoir tank.
- Pre-mix washer fluid concentrates with water to the manufacturer's recommended levels before pouring the fluid into the window washer reservoir tank. Do not use the window washer reservoir tank to mix the washer fluid concentrate and water.

If the rear window wiper operation is interrupted by snow or ice, the wiper may stop moving to protect its motor. If this occurs, turn the wiper switch to the OFF position and remove the snow or ice that is on and around the wiper

arms. In approximately 1 minute, turn the switch on again to operate the wiper.

REAR WINDOW AND OUTSIDE MIRROR (if so equipped) DEFROSTER SWITCH

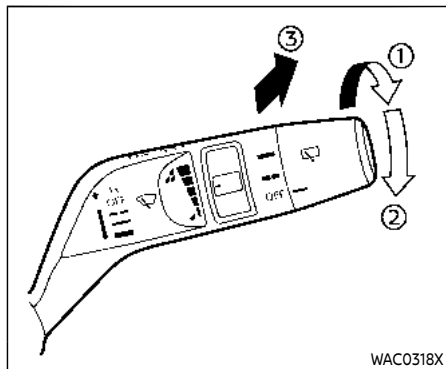

The rear window wiper and washer operate when the ignition switch is in the ON position.

Turn the switch clockwise from the OFF position to operate the wiper.

- ① Intermittent (INT) – intermittent operation (not adjustable)
- ② Low (ON) – continuous low speed operation

Push the switch forward ③ to operate the washer. Then the wiper will also operate several times.

Reverse Link feature:

When the windshield wiper switch is on, moving the shift lever to the R (Reverse) position will operate the rear window

wiper.

NOTE:

The Reverse Link feature may be disabled. For additional information, refer to "Vehicle Settings" (P.2-28).

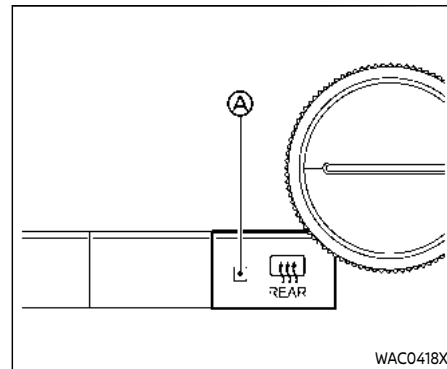

Type A (if so equipped)

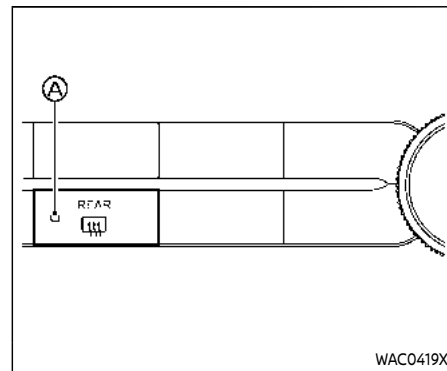

Type B (if so equipped)

HEADLIGHT AND TURN SIGNAL SWITCH

HEADLIGHT SWITCH



CAUTION

Use the headlights with the engine running to avoid discharging the vehicle battery.

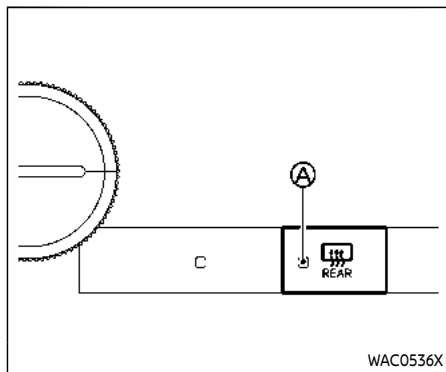

Type C (if so equipped)

To defog/defrost the rear window glass and outside mirrors (if so equipped), start the engine and push the switch on. The indicator light **A** will illuminate. Push the switch again to turn the defroster off.

It will automatically turn off in approximately 20 minutes.



CAUTION

When cleaning the inner side of the rear window, be careful not to scratch or damage the rear window defroster.

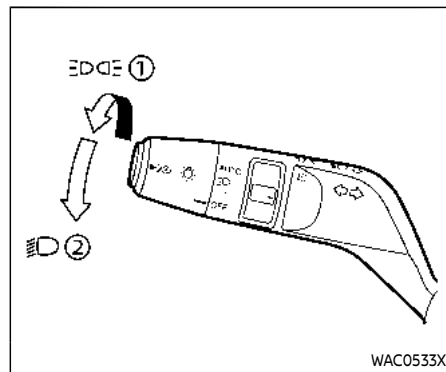

Example

Lighting

Type A (if so equipped):

- ① Rotate the switch to the **OFF** position, and the front parking, tail, license plate, and instrument panel lights will come on.
- ② Rotate the switch to the **HEADLIGHTS** position, and the headlights will come on and all the other lights remain on. The daytime running light will turn off.

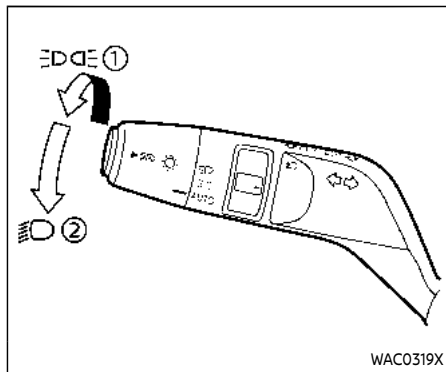

Example

Type B (if so equipped):

- ① Rotate the switch to the OFF position, and the front parking, tail, license plate, and instrument panel lights will come on.
The Intelligent Auto Headlight system will also be set in this position.
- ② Rotate the switch to the AUTO position, and the headlights will come on and all the other lights remain on. The daytime running light will turn off.

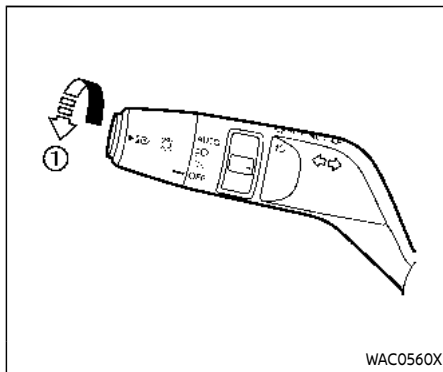

Example

Intelligent Auto Headlight system

Type A (if so equipped):

The Intelligent Auto Headlight system allows the headlights to be set so they turn on and off automatically.

To set the Intelligent Auto Headlight system:

1. Make sure the headlight switch is in the AUTO position ①.
2. Place the ignition switch in the ON position.
3. The Intelligent Auto Headlight system automatically turns the headlights on and off.

To turn the Intelligent Auto Headlight system off, turn the switch to the OFF, OFF, or OFF position.

The Intelligent Auto Headlight system can turn on the headlights automatically when it is dark and turn off the headlights when it is light.

The headlights will also be turned on automatically at twilight or in rainy weather (when the windshield wiper is operated continuously).

If the ignition switch is placed in the OFF position and one of the doors is opened and this condition is continued, the headlights remain on for 5 minutes.

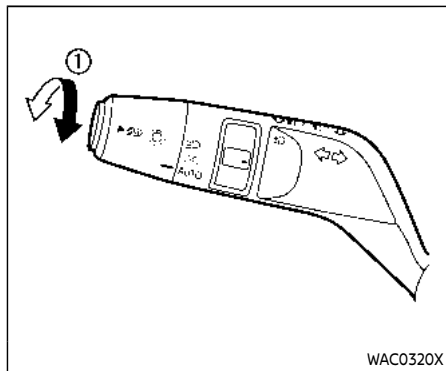

Example

Type B (if so equipped):

The Intelligent Auto Headlight system allows the headlights to be set so they turn on and off automatically.

To set the Intelligent Auto Headlight system:

1. Make sure the headlight switch is in the **OFF** or **AUTO** position ①.
2. Place the ignition switch in the **ON** position.
3. The Intelligent Auto Headlight system automatically turns the headlights on and off.

To turn the Intelligent Auto Headlight system off, turn the switch to the 

position.

The Intelligent Auto Headlight system can turn on the headlights automatically when it is dark and turn off the headlights when it is light.

If the ignition switch is placed in the **ON** position when the parking brake is applied, the headlights remain off.

With the **OFF** position selected, the headlights turn off when the ignition switch is placed in the **OFF** position, the shift position is placed in the **P** (Park) position or the parking brake is applied. (The front parking, tail, license plate, and instrument panel lights are on.)

The headlights will also be turned on automatically at twilight or in rainy weather (when the windshield wiper is operated continuously).

With the **AUTO** position selected (headlights are on), if the ignition switch is placed in the **OFF** position and one of the doors is opened and this condition is continued, the headlights remain on for 5 minutes.

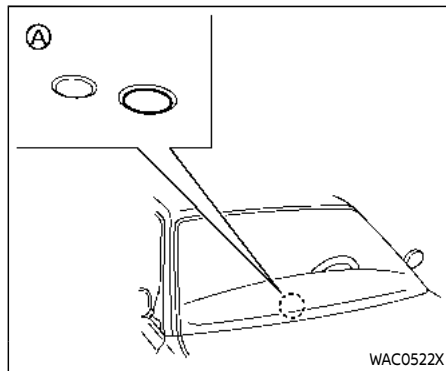

Be sure not to put anything on top of the photo sensor **A located on the top of the instrument panel. The photo sensor controls the Intelligent Auto Headlight; if it is covered, the photo sensor reacts as if it is dark and the headlights will illuminate.**

Automatic headlights off delay:

You can keep the headlights on for up to 180 seconds after you place the ignition switch in the **OFF** and open any door then close all the doors. You can adjust the period of the automatic headlights off delay from 0 seconds (**OFF**) to 180 seconds. The factory default setting is 45 seconds.

For automatic headlights off delay setting, see "Vehicle Settings" (P.2-28).

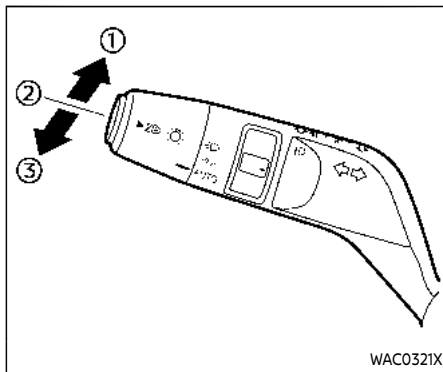

Example

Headlight beam select

- ① To select the high beam, push the lever forward and release it. The high beam lights come on and the  light illuminates.
- ② Pull the lever back and release it to select the low beam.
- ③ To flash the headlights when the high beam is not selected, pull the lever towards the rear position. To flash the headlights when the high beam is selected, pull the lever twice towards the rear position.

High beam assist

The high beam assist system will operate when the vehicle is driven at speeds of approximately 19 MPH (30 km/h) and above. If an oncoming vehicle or leading vehicle appears in front of your vehicle when the headlight high beam is on, the headlight will be switched to the low beam automatically.

Precautions on high beam assist:



WARNING

- **The high beam assist system is a convenience but it is not a substitute for safe driving operation. The driver should remain alert at all times, ensure safe driving practices and switch the high beams and low beam manually when necessary.**
- **The high beam or low beam may not switch automatically under the following conditions. Switch the high beam and low beam manually.**
 - During bad weather (rain, fog, snow, wind, etc.).
 - When a light source similar to a headlight or tail light is in

the vicinity of the vehicle.

- When the headlights of the oncoming vehicle or the leading vehicle are turned off, when the color of the light is affected due to foreign materials on the lights, or when the light beam is out of position.
- When there is a sudden, continuous change in brightness.
- When driving on a road that passes over rolling hills, or a road that has level differences.
- When driving on a road with many curves.
- When a sign or mirror-like surface is reflecting intense light towards the front of the vehicle.
- When the container, etc. being towed by a leading vehicle is reflecting intense light.
- When a headlight on your vehicle is damaged or dirty.
- When the vehicle is leaning at an angle due to a punctured tire, being towed, etc.

- The timing of switching the low beam and high beam may change under the following situations.
 - The brightness of the headlights of the oncoming vehicle or leading vehicle.
 - The movement and direction of the oncoming vehicle and the leading vehicle.
 - When only one light on the oncoming vehicle or the leading vehicle is illuminated.
 - When the oncoming vehicle or the leading vehicle is a two-wheeled vehicle.
 - Road conditions (incline, curve, the road surface, etc.).
 - The number of passengers and the amount of cargo.

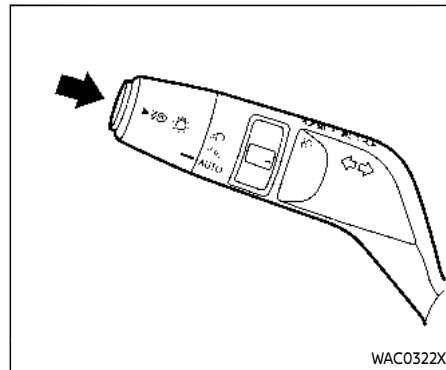

Example

High beam assist operations:

To activate the high beam assist system, push the switch as illustrated with the AUTO position (or  position, depending on the model). The high beam assist indicator light in the meter will illuminate while the headlights are turned on.

If the high beam assist indicator light does not illuminate in the above condition, it may indicate that the system is not functioning properly. It is recommended you have the system checked by a NISSAN dealer.

When the vehicle speed lowers to less than approximately 13 MPH (20 km/h), the

headlight remains the low beam.

To turn off the high beam assist system, push the switch again.

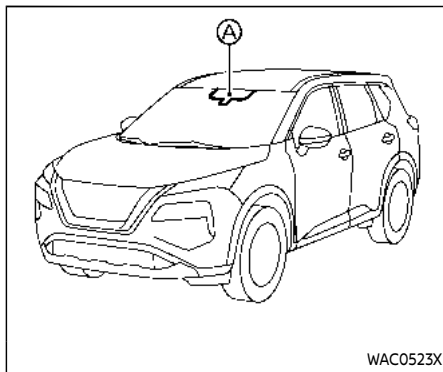





Ambient image sensor maintenance:

The ambient image sensor (A) for the high beam assist system is located in front of the inside mirror. To keep the proper operation of the high beam assist system and prevent a system malfunction, be sure to observe the following:

- Always keep the windshield clean.
- Do not attach a sticker (including transparent material) or install an accessory near the ambient image sensor.
- Do not strike or damage the areas around the ambient image sensor. Do not touch the sensor lens that is located on the ambient image sensor.

If the ambient image sensor is damaged due to an accident, it is recommended you contact a NISSAN dealer.

Battery saver system

- When the headlight switch is in the  or  position while the ignition switch is in the ON position, the lights will automatically turn off within a period of time after the ignition switch has been placed in the OFF position.
- When the headlight switch remains in the  or  position after the lights automatically turn off, the lights will turn on when the ignition switch is placed in the ON position.



CAUTION

- **When you turn on the headlight switch again after the lights automatically turn off, the lights will not turn off automatically. Be sure to turn the light switch to the OFF (if so equipped) or the AUTO position when you leave the vehicle for extended periods of time, otherwise the battery will be discharged.**
- **Never leave the light switch on when the engine is not running**

for extended periods of time even if the headlights turn off automatically.

Daytime Running Light (DRL) system

The LED Daytime Running Lights (DRL) automatically illuminate when the engine is started and the parking brake is released. The LED DRL operate with the headlight switch in the OFF (if so equipped), DRL , or AUTO (when the headlights are off) position. When you turn the headlight switch to the OFF position for full illumination, the LED lights switch from LED DRL to the park function.

Type A: If the parking brake is applied before the engine is started, the LED DRL do not illuminate. The LED DRL illuminate when the parking brake is released. This feature will work in the DRL , AUTO or OFF position. The LED DRL will remain on until the ignition switch is placed in the OFF position.

Type B: If the parking brake is applied before the engine is started, the LED DRL do not illuminate. The LED DRL illuminate when the parking brake is released. This feature will work in the AUTO or DRL position. The LED DRL will remain on until the ignition switch is placed in the OFF

position.

WARNING

When the LED DRL system is active with the headlight switch in the OFF position (if so equipped), tail lights on your vehicle are not on. It is necessary at dusk to turn on your headlights. Failure to do so could cause an accident injuring yourself and others.

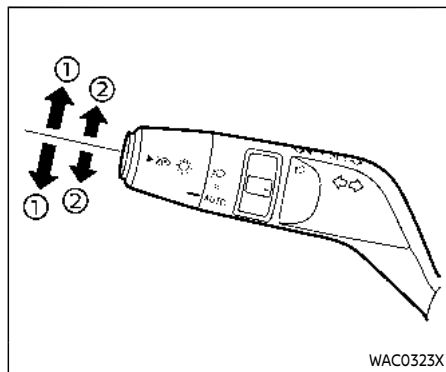

Example

TURN SIGNAL SWITCH

① Turn signal

Move the lever up or down to signal the turning direction. When the turn is completed, the turn signals cancel automatically.

② Lane change signal

Move the lever up or down until the turn signal begins to flash, but the lever does not latch, to signal a lane change. Hold the lever until the lane change is completed.

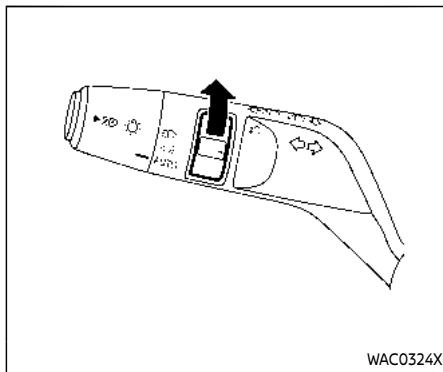

Move the lever up or down until the turn signal begins to flash, but the lever does

not latch, and release the lever. The turn signal will automatically flash three times. Choose the appropriate method to signal a lane change based on road and traffic conditions.



Example

FOG LIGHT SWITCH (if so equipped)

To turn the fog lights on, turn the headlight switch to the  position, then turn the fog light switch to the  position.

To turn the fog lights on with the headlight switch in the AUTO position, the headlights must be on, then turn the fog light switch to the  position.

To turn them off, turn the fog light switch to the OFF position.

The headlights must be on for the fog lights to operate.

The fog lights automatically turn off when the high beam headlights are selected.

HORN

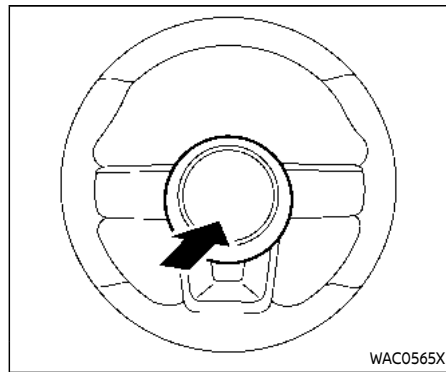

To sound the horn, push the center pad area of the steering wheel.



WARNING

Do not disassemble the horn. Doing so could affect proper operation of the supplemental front air bag system. Tampering with the supplemental front air bag system may result in serious personal injury.

HEATED STEERING WHEEL (if so equipped)

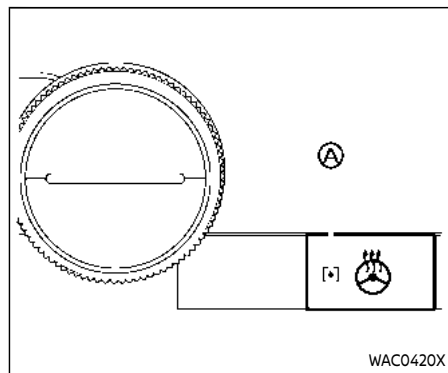

Example

Push the heated steering wheel switch to warm the steering wheel after the engine starts. The indicator light (A) on the switch will illuminate.

If the surface temperature of the steering wheel is below 86 to 104°F (30 to 40°C), the system will heat the steering wheel and cycle off and on to maintain a temperature above 86 to 104°F (30 to 40°C). The indicator light will remain on as long as the system is on.

The heated steering wheel system is automatically turned off after 30 minutes.

Push the switch again to turn the heated steering wheel system off manually. The indicator light will turn off.

HEATED SEATS (if so equipped)

WARNING

Do not use or allow occupants to use the seat heater if you or the occupants cannot monitor elevated seat temperatures or have an inability to feel pain in body parts that contact the seat. Use of the seat heater by such people could result in serious injury.

CAUTION

- The battery could run down if the seat heater is operated while the engine is not running.
- Do not use the seat heater for extended periods or when no one is using the seat.
- Do not put anything on the seat which insulates heat, such as a blanket, cushion, seat cover, etc. Otherwise, the seat may become overheated.
- Do not place anything hard or heavy on the seat or pierce it with a pin or similar object. This may result in damage to the heater.

- Any liquid spilled on the heated seat should be removed immediately with a dry cloth.
- When cleaning the seat, never use gasoline, thinner, or any similar materials.
- If any malfunctions are found or the heated seat does not operate, turn the switch off and have the system checked. It is recommended you visit a NISSAN dealer for this service.

STEERING ASSIST SWITCH (models with ProPILOT Assist)

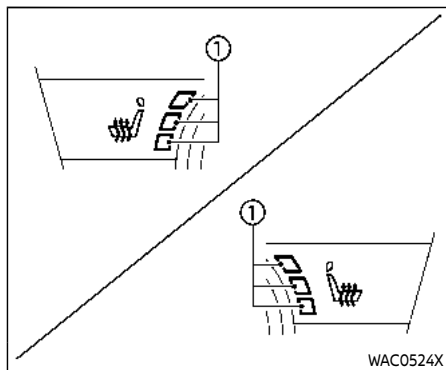

Front

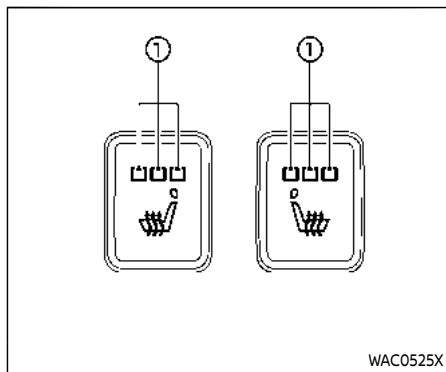

Rear (if so equipped)

The front and rear (if so equipped) seats are warmed by built-in heaters. The switches are located on the instrument panel and the back of the center console box and can be operated independently of each other.

OPERATION WITH SWITCH

1. Start the engine.
2. Push the heated seat switch and select the desired heat range.
 - For high heat, push the switch once.
 - For medium heat, push the switch twice.
 - For low heat, push the switch three times.
 - The indicator light ① on the switch will illuminate depending on the heat level when the heater is on.
3. To turn off the heater, push the heated seat switch until the indicator light turns off.

The heater is controlled by a control module, automatically adjusting the heat level to maintain comfort according to the selected heat range.

The indicator light will remain on as long as the switch is on.

When the vehicle's interior is warmed, or before you leave the vehicle, be sure to turn off the seat heater.

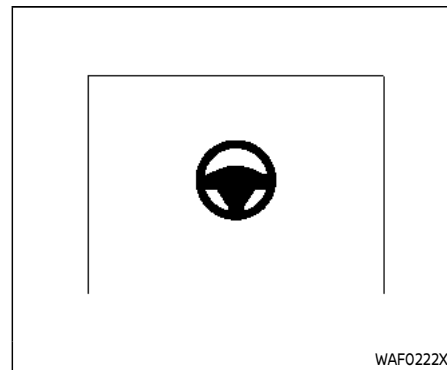

The Steering Assist switch is used to temporarily turn on and off the Steering Assist system.

You can also use the "Driver Assistance" menu in the vehicle information display to turn on and off the Steering Assist system. (See "How to enable/disable the Steering Assist" (P.5-97).)

The Steering Assist system controls the steering system to help keep your vehicle near the center of the lane when driving. (See "ProPILOT Assist" (P.5-85).)

REAR DOOR ALERT

The Rear Door Alert system functions under certain conditions to indicate there may be an object or passenger in the rear seat(s). Check the seat(s) before exiting the vehicle.

The Rear Door Alert system is initially disabled. The driver can enable the system using the vehicle information display. (See "Vehicle Settings" (P.2-28).)

When the system is enabled:

- The system is activated when a rear door is opened and closed. When the vehicle is started and the system is activated, a visual message appears in the vehicle information display. (See "31. Rear Door Alert is activated indicator" (P.2-38).)
- If a rear door is opened and closed but the vehicle is not driven, the system will not be activated. A rear door must be opened and closed and the car driven for the system to activate.
- The time interval to activate the system between when the rear door is opened and closed and the vehicle is started is about 10 minutes. A longer interval does not indicate a malfunction.

When the Rear Door Alert system is activated:

- When the driver puts the vehicle in the P (Park) position, a notification message appears in the vehicle information display with the options to "Dismiss Message" or "Disable Alert" if desired.
 - Select "Disable Alert" to temporarily disable for that stop.
 - No selection or "Dismiss Message" will keep the alert enabled for that stop.
- If the alert is enabled when a driver exits the vehicle, a message will appear in the vehicle information display that states "Check Rear Seat for All Articles."
 - If "Horn & Alert" setting is selected:
 - An audible horn sound will occur after a short time unless a rear door is opened and closed within a short time to deactivate the alert.
 - If the doors are locked before the alert is deactivated by opening a rear door, the horn will sound.
 - If the liftgate is opened before a rear door is opened, the horn will be delayed until after the liftgate is closed.

NOTE:

If "Alert Only" setting is selected, the message alert will still be shown in the

vehicle information display but the horn will not sound.



WARNING

- **If the driver selects "Disable Alert", no audible alert will be provided regardless of rear door open/close status.**
- **There may be times when there is an object or passenger in the rear seat(s) but the audible alert does not sound. For example, this may occur if rear seat passengers enter or exit the vehicle during a trip.**
- **The system does not directly detect objects or passengers in the rear seat(s). Instead, it can detect when a rear door is opened and closed, indicating that there may be something in the rear seat(s).**

NOTE:

There may be times when the horn sounds but there are no objects or passengers in the rear seat(s).

(See "31. Rear Door Alert is activated indicator" (P.2-38).)

POWER OUTLETS

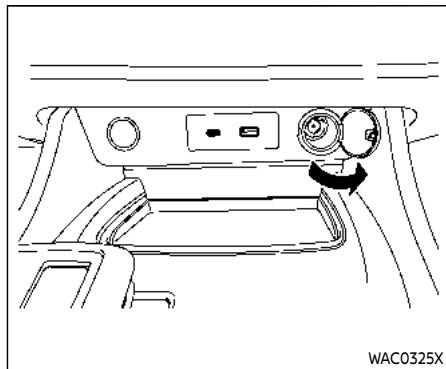

Instrument Panel

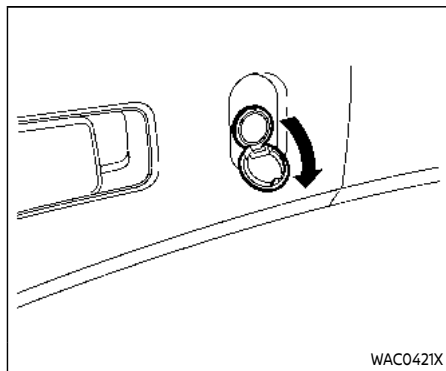

Luggage area (if so equipped)

The power outlets are located in the lower part of the instrument panel and in the luggage area (if so equipped).



CAUTION

- The outlet and plug may be hot during or immediately after use.
- Do not use with accessories that exceed a 12 volt, 120W (10A) power draw. Do not use double adapters or more than one electrical accessory.
- Use power outlet with the engine running to avoid discharging the vehicle battery.
- Avoid using power outlet when the air conditioner, headlights or rear window defroster is on.
- This power outlet is not designed for use with a cigarette lighter unit.
- Push the plug in as far as it will go. If good contact is not made, the plug may overheat.
- Before inserting or disconnecting a plug, be sure the electrical accessory being used is turned OFF.

- When not in use, be sure to close the cap. Do not allow water or any liquid to contact the outlet.

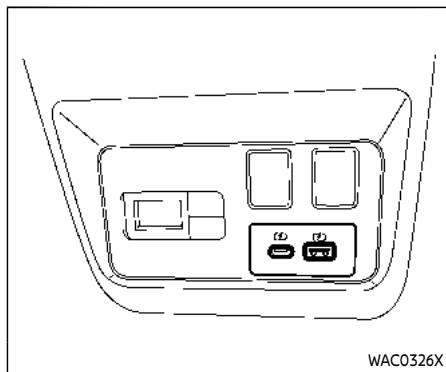

USB (Universal Serial Bus) CHARGING CONNECTOR (if so equipped)

The USB charging connector is located on the back of the center console box.

The USB charging connector can be used only for charging an external device.

Connect a USB device into the connector. Charging will start automatically (maximum output up to 5 volt, 12W, 2.4A).

The external device will be charged continuously while the ignition switch is in the ON position.

Some mobile devices cannot be charged depending on their specifications.

CAUTION

- Do not force a USB device into the connector. Depending on the USB connector, inserting the USB device tilted or upside down may damage the connector. Make sure that the USB device is connected correctly into the connector.
- Do not use a reversible USB cable. Using the reversible USB cable may damage the connector.

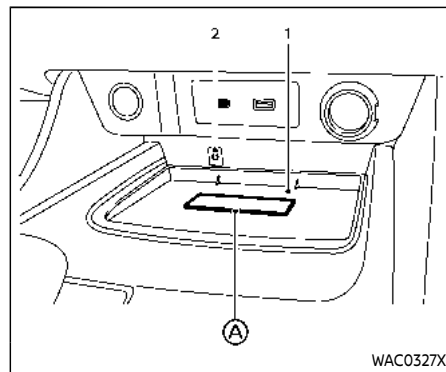

1. Charging pad
2. Indicator

WIRELESS CHARGER (if so equipped)

The wireless charger is located on the front of the center console. Lay the smartphone on the pad of the wireless charger. Charging will start automatically. The smartphone will be charged continuously while the ignition switch is in the ON position.



WARNING

- Never put metallic materials between the wireless charger and a smartphone.
- Those who use a pacemaker or other medical equipment should contact the electric medical equipment manufacturer for the possible influences before use.
- Never put cloth over the smartphone during charging process.
- Never charge a smartphone when it is wet.
- Never put metallic materials or small goods such as a cigarette lighter, Intelligent Key or memory drive.



CAUTION

- Do not put an RFID/NFC/credit card between the wireless charger and a smartphone. This could cause data corruption in the card.
- Do not use the wireless charger with dust accumulated or dirt on the pad.

- Do not hit the surface of the wireless charger.
- Do not spill liquid (water, drinks, etc.) on the charging pad.
- Do not use grease, oil or alcohol for cleaning charging pad.

Wireless charger Indicator

The indicator  will illuminate in orange when the charging process is started.

When the charging has completed, the indicator illuminates in green.

If a malfunction occurs or the charging process has stopped, the indicator will blink in orange for 8 seconds then turn off.

Operation of the wireless charger

To use the wireless charger, it is necessary to seat the smartphone well within the charging pad. To maximize charging performance, ensure the smartphone is fully seated on the center of the charging pad over the "Qi" logo . Because the location of the power receiver may vary depending on the smartphone, you will need to try and find the area that suits your smartphone.

Because some smartphone cases or accessories may adversely affect charging,

remove them before wireless charging.

Turn off the vibration function of the smartphone before wireless charging.

NOTE:

- Only a Qi compatible smartphone can be used.
- The smartphone or the wireless charger may be warmed during charging process and the charging may stop by the protection function of the smartphone or the wireless charger. This is not a malfunction. If this occurs, restart charging after the smartphone or the wireless charger cooled down. The indicator will blink in orange then turn off.
- The wireless charging process may be stopped by the status of the smartphone (battery temperature, etc.).
- If a radio noise interference occurs during charging process, put the smartphone onto the center ("Qi" logo) position of the wireless charger.
- The wireless charging process will stop during process of searching the Intelligent Key.
- The wireless charging process will not be started when a USB (Universal Serial Bus) cable is connected to the smartphone. The indicator may

illuminate in orange or blink if the smartphone is put on the wireless charger with a USB cable connected. However, charging is not performed.

- Depending on the type of the smartphone, the indicator may remain illuminated in orange even when the charging process has been completed.

FCC ID: BEJWC500MNM

IC: 2703H-WC500MNM

This device complies with part 15 of the FCC Rules and RSS-Gen of IC Rules.

Operation is subject to the following two conditions:

- (1) This device may not cause harmful interference, and
- (2) This device must accept any interference received, including interference that may cause undesired operation.

Changes or modifications not expressly approved by the party responsible for compliance could void the user's authority to operate the equipment.

RF Radiation Exposure Statement: This equipment complies with FCC RF Radiation exposure limits set forth for an uncontrolled environment.

This device and its antenna must not be co-located or operating in conjunction

with any other antenna or transmitter. This equipment should be installed and operated with a minimum distance of 15cm between the radiator and your body.

ISED Compliance Statement

This device complies with RSS-Gen of IC Rules

Operation is subject to the following two conditions:

- (1) This device may not cause harmful interference, and
- (2) This device must accept any interference received, including interference that may cause undesired operation.

Changes or modifications made to this device, not expressly approved by LG Vehicle Components Company, will void the user's authority to operate the equipment.

ISED RF Radiation Exposure Statement: This equipment complies with ISED RF Radiation exposure limits set forth for an uncontrolled environment. This device and its antenna must not be co-located or operating in conjunction with any other antenna or transmitter. This equipment should be installed to operate with a minimum distance of 15cm

between the radiator and the end-user's body and arms.

EMERGENCY CALL (SOS) BUTTON (if so equipped)

EMERGENCY SUPPORT

NissanConnect® Services provide various services to support dealing with emergencies of the subscribed vehicle and the driver.

For example, in case of an illness or serious injury, you can seek support by pushing the in-vehicle Emergency Call (SOS) button and connecting to the NissanConnect® Services Response Center. The NissanConnect® Services Response Center can specify the location of the vehicle via GPS, and the information will be sent to the police or other agencies as needed.

For information about other NissanConnect® Services emergency support related services, contact the NissanConnect® Customer Support line at 1-855-426-6628 or refer to the NissanConnect® Services website www.nissanusa.com/connect (for U.S.) or www.nissan.ca/nissanconnect (English)/www.nissan.ca/nissanconnect/fr (French) (for Canada).



WARNING

- **Please note that the Automatic Collision Notification service and Emergency Call function cannot**

be used in the following conditions:

- **Emergency functions and services will not be available without a paid subscription to NissanConnect® Services.**
- **The NissanConnect® Services network system is disabled.**
- **The vehicle moves outside the service area where the TCU (Telematics Control Unit) is connected to the system.**
- **The vehicle is outside the area where the cellular network service is receivable.**
- **The vehicle is in a location with poor signal reception such as tunnels, underground parking garages, behind buildings or in mountainous areas.**
- **The line is busy.**
- **The TCU (Telematics Control Unit) or other systems of your vehicle are not working properly.**
- **It may not be possible to make an emergency call depending on the severity of a**

collision and/or emergency.

- **Park the vehicle in a safe location and set the parking brake before operating the Emergency Call (SOS) button.**
- **Only use this service in case of an emergency. There may be a penalty for inappropriate use of the service.**
- **Radio waves could adversely affect electric medical equipment. Individuals who use a pacemaker should contact the device manufacturer regarding any possible effects before using the system.**
- **The TCU (Telematics Control Unit) antenna is installed inside the upper central part of the instrument panel. An occupant should not get any closer to the antenna than specified by the pacemaker manufacturer. The radio waves from the TCU antenna may adversely affect the operation of the pacemaker while using the NissanConnect® Services.**

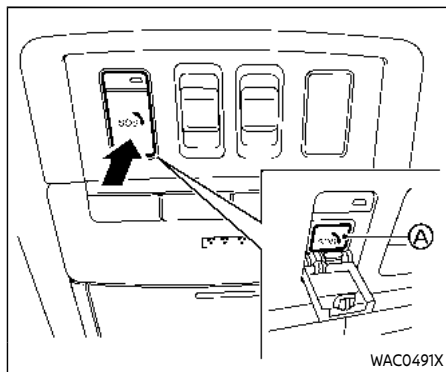

Making an emergency call

The Emergency Call (SOS) button is located near the map light.

1. Push the cover to expose the Emergency Call (SOS) button **A**.
2. Push the Emergency Call (SOS) button to make an emergency call.
3. When the line is connected, speak to the Response Specialist.

If you want to cancel the emergency call, push and hold the Emergency Call (SOS) button for a few seconds.

NOTE:

- After the Emergency Call (SOS) button is pushed, it may take some time until the system initiates connection, depending on the technical environment and whether the TCU (Telematics Control Unit) is being used by other services.
- An indicator light on the Emergency Call (SOS) button shows the readiness of the emergency support system. If the indicator light is not illuminated, pushing the Emergency Call (SOS) button does not connect your vehicle to the Response Specialist.

The indicator light blinks while connected to the NissanConnect® Services Response Center.

- Even when the indicator light is illuminated, connection to the NissanConnect® Services Response Center may not be possible. If this occurs in an emergency situation, contact the authorities by other means.
- To avoid disconnecting the line, keep the engine running during an emergency call, if it is safe to do so.

STORAGE

CUP HOLDERS



CAUTION

- Avoid abrupt starting and braking when the cup holder is being used to prevent spilling the drink. If the liquid is hot, it can scald you or your passenger.
- Use only soft cups in the cup holder. Hard objects can injure you in an accident.

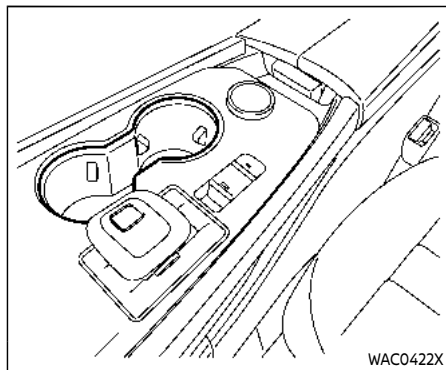

Center console

Front

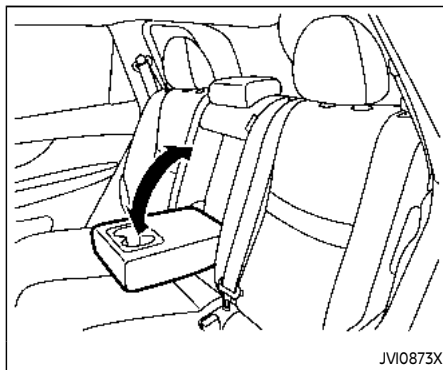

Rear seat

The rear cup holders are located in the rear fold-down armrest.

SOFT BOTTLE HOLDERS



CAUTION

- Do not use bottle holder for any other objects that could be thrown about in the vehicle and possibly injure people during sudden braking or an accident.
- Do not use bottle holder for open liquid containers.

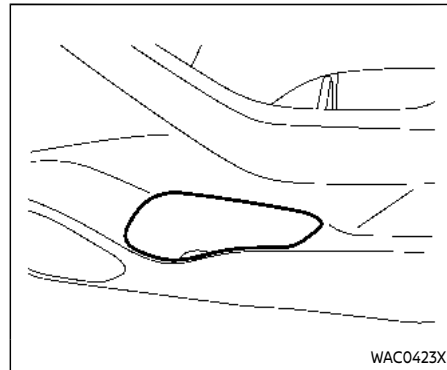

Door (front and rear)

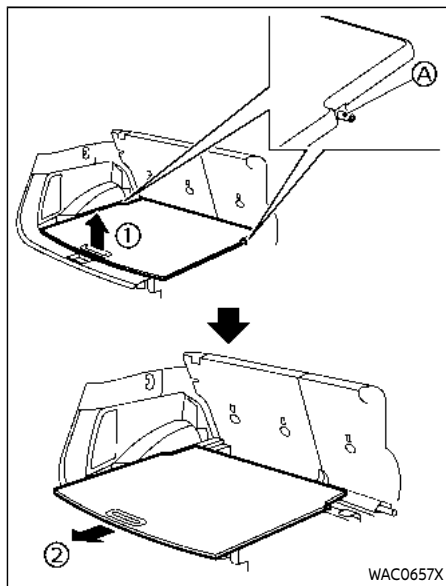

SINGLE LUGGAGE BOARD (if so equipped)

The luggage board is secured by two retainer pins Ⓐ.

To ensure proper removal and prevent part damage, perform the following procedure:

1. Pull the board slightly up. Do not lift up largely.
2. Pull the board rearward to disengage front retainer pins Ⓐ.
3. Remove the board from the vehicle.

When reinstalling the board to the vehicle, put the retainer pins Ⓐ in the original location.

ADJUSTABLE LUGGAGE FLOOR (if so equipped)

You can use the luggage compartment in different ways using the adjustable luggage boards.



WARNING

Do not put objects heavier than 165 lbs (75 kg) on the load floor while in the upper position.



CAUTION

- **Do not push the front edge of the luggage board forcibly. Doing so may cause the luggage board to be tilted, resulting in personal injury.**

- **Do not handle the luggage board forcibly as this may deform it.**
- **While in the upper position, do not recline the seatbacks.**
- **Do not place cargo higher than the seatbacks. In a sudden stop or collision, unsecured cargo could cause personal injury.**

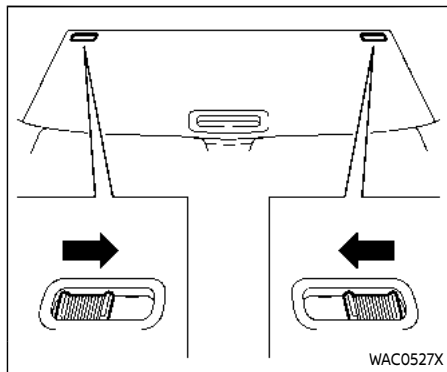

Before moving the rear (outer) luggage board, release the lock on the both sides of the board as shown.

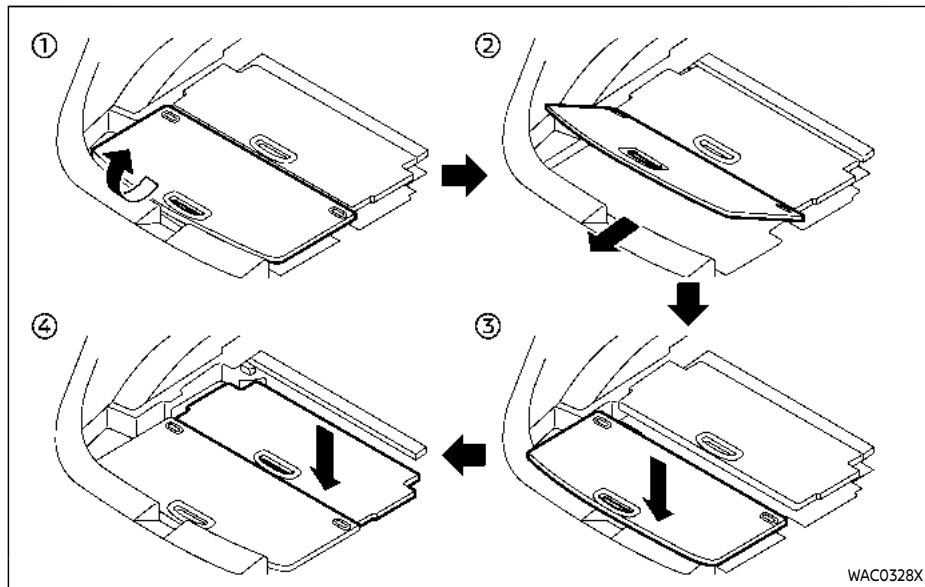

Two-stage mode

1. Pull the rear board upward ① to approximately 30°.
2. Pull the rear board toward the rear of the vehicle ② and then push it into the bottom of the luggage under space ③.
3. Pull up the front (inner) board and push it into the bottom of the luggage under space in the same way ④.

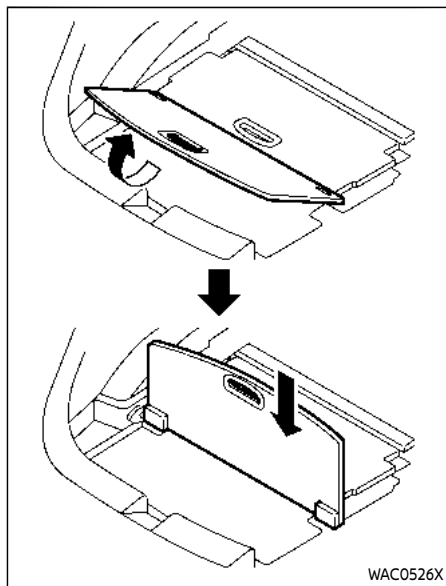

Vertical mode

1. Pull the rear board upward to 90°.
2. Push down the board until it stops.

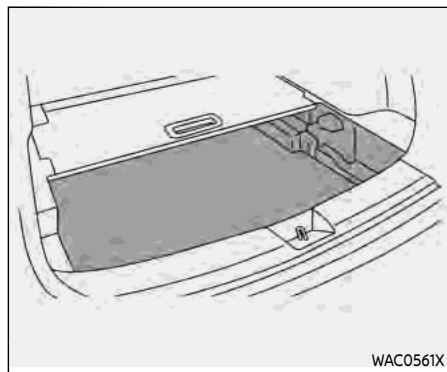

Luggage under space

To use the luggage under space, pull off the rear board.

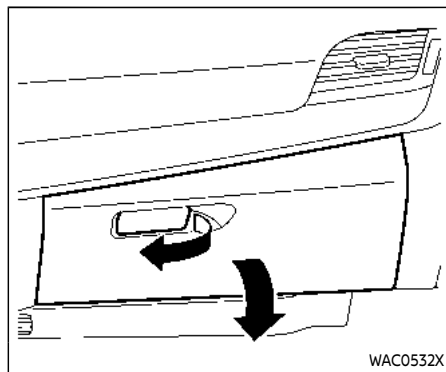

GLOVE BOX



WARNING

Keep glove box lid closed while driving to help prevent injury in an accident or a sudden stop.

To open the glove box, pull the handle.

To close, push the lid in until the lock latches.

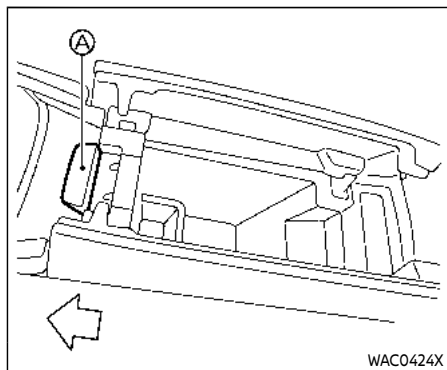

CONSOLE BOX

To open the console box lids, push the knob Ⓐ in the rearward.

To close, push each lid down until the lock latches.

If something is put on top of either side of the lids, that side lid may not open. Remove any object and push the knob again to open the lid.

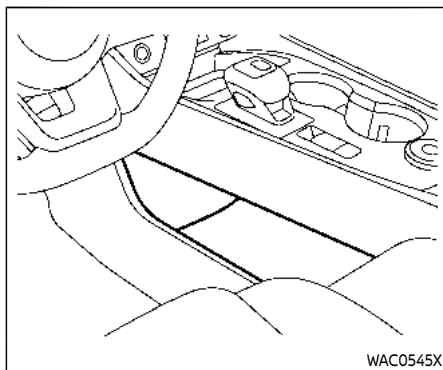

LOWER CONSOLE TRAY



CAUTION

Do not place any objects in lower console tray that could be thrown about in the vehicle and cause injury during sudden braking or collision.

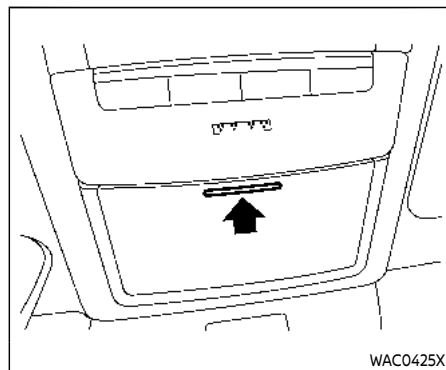

SUNGLASSES HOLDER



WARNING

Keep the sunglasses holder closed while driving to avoid obstructing the driver's view and to help prevent an accident.



CAUTION

- **Do not use for anything other than sunglasses.**

- **Do not leave sunglasses in the sunglasses holder while parking in direct sunlight. The heat may damage the sunglasses.**

To open the sunglasses holder, push and release. Only store one pair of sunglasses in the holder.

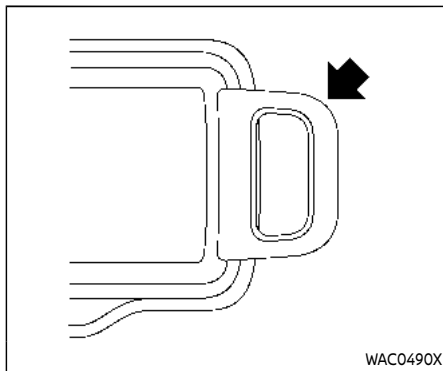

CARD HOLDER

Slide a card in the card holder.

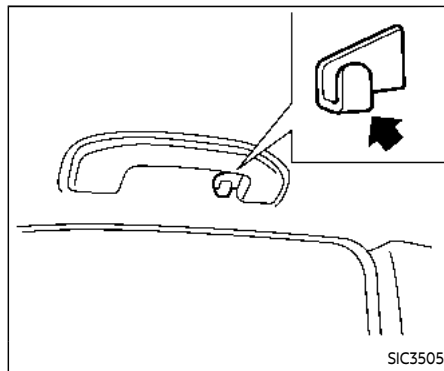

COAT HOOKS (if so equipped)

The coat hook is located above the rear side window.



CAUTION

Do not apply a total load of more than 2 lb (1 kg) to the hook.

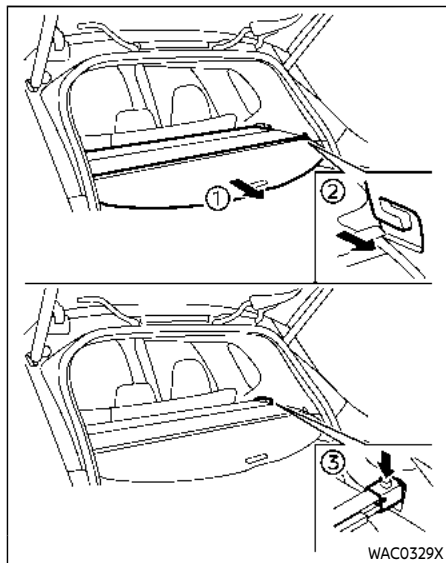

CARGO COVER (if so equipped)

The cargo cover keeps the luggage compartment contents hidden from the outside.

To use the cargo cover, pull it out ① and insert both sides to the guide ②.

To remove the cargo cover, stow the cover and push the button ③.

WARNING

- Never put anything on the cargo cover, no matter how small. Any object on it could cause an injury in an accident or sudden stop.
- Do not leave the cargo cover in the vehicle with it disengaged from the holder.
- The child restraint top tether strap may be damaged by contact with the cargo cover or items in the luggage area. Remove the cargo cover from the vehicle or secure it in the luggage area. Also secure any items in the luggage area. Your child could be seriously injured or killed in a collision if the top tether strap is damaged.

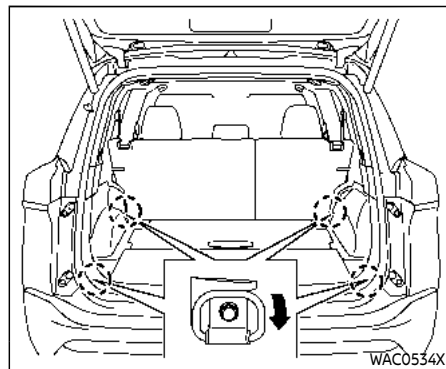

LUGGAGE HOOKS

To use the hook, pull it down as illustrated.

WARNING

- Always make sure that the cargo is properly secured. Use the suitable ropes and hooks.
- Unsecured cargo can become dangerous in an accident or sudden stop.
- Do not apply a total load of more than 22 lb (10 kg) to a single hook.

ROOF RACK (if so equipped)

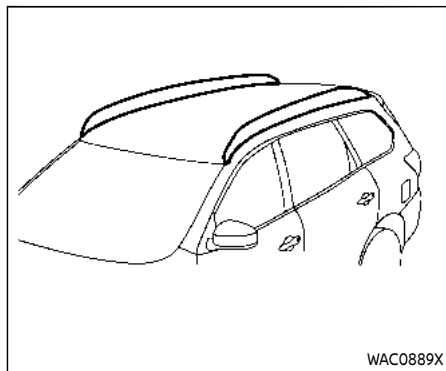

Do not apply any load directly to the roof side rails. Cross bars must be installed before applying load/cargo/luggage to the roof of the vehicle. Genuine NISSAN accessory cross bars are available through a NISSAN dealer. It is recommended that you visit a NISSAN dealer for additional information.

The service load capacity for the roof side rails is 163 lb (74 kg), however do not exceed the accessory cross bars load capacity.

Be careful that your vehicle does not exceed the Gross Vehicle Weight Rating (GVWR) or its Gross Axle Weight Rating (GAWR front and rear). The GVWR and

GAWR are located on the F.M.V.S.S. or C.V. M.S.S. certification label (located on the driver's door pillar). For additional information regarding GVWR and GAWR, refer to "Vehicle loading information" (P.10-15).

WARNING

- **Always install the cross bars onto the roof side rails before loading cargo of any kind. Loading cargo directly onto the roof side rails or the vehicle's roof may cause vehicle damage.**
- **Drive extra carefully when the vehicle is loaded at or near the cargo carrying capacity, especially if the significant portion of that load is carried on the cross bars.**
- **Heavy loading of the cross bars has the potential to affect the vehicle stability and handling during sudden or unusual handling maneuvers.**
- **Roof rack cross bars should be evenly distributed.**
- **Do not exceed maximum roof rack cross bars load.**

- **Properly secure all cargo with ropes or straps to help prevent it from sliding or shifting. In a sudden stop or collision, unsecured cargo could cause personal injury.**

CAUTION

Use care when placing or removing items from the roof rack. If you cannot comfortably lift the items onto the roof rack from the ground, use a ladder or a stool.

WINDOWS

POWER WINDOWS



WARNING

- Make sure that all passengers have their hands, etc. inside the vehicle while it is in motion and before closing the windows. Use the window lock switch to prevent unexpected use of the power windows.
- To help avoid risk of injury or death through unintended operation of the vehicle and or its systems, including entrapment in windows or inadvertent door lock activation, do not leave children, people who require the assistance of others or pets unattended in your vehicle. Additionally, the temperature inside a closed vehicle on a warm day can quickly become high enough to cause a significant risk of injury or death to people and pets.

The power windows operate when the ignition switch is in the ON position, or for a period of time after the ignition switch is placed in the OFF position. If the driver's or front passenger's door is opened dur-

ing this period of time, power to the windows is canceled.

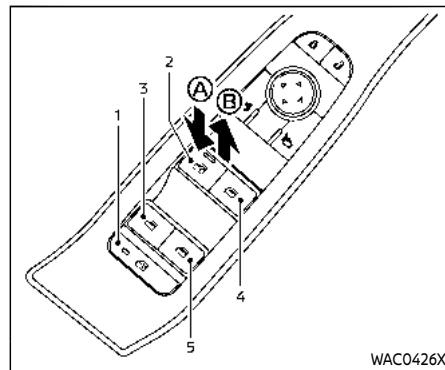

1. Window lock button
2. Driver side window
3. Rear left passenger side window
4. Front passenger side window
5. Rear right passenger side window

Main power window switch (driver's side)

To open or close the window, push down Ⓐ or pull up Ⓑ the switch and hold it. The main switch (driver side switches) will open or close all the windows.

Locking rear passenger's windows

When the window lock button is pushed (the indicator illuminates), the rear passenger's windows cannot be operated with the rear passenger's power window switch. The rear passenger's windows can only be operated with the main switch (driver side switches). To cancel the passenger's windows lock, push the window lock button again.

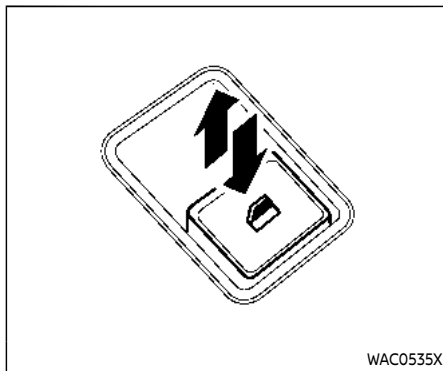

WAC0535X

Passenger side power window switch

The passenger's switch can control its corresponding window. When the window lock button on the driver's switch is pushed, the rear passenger's switch cannot be operated.

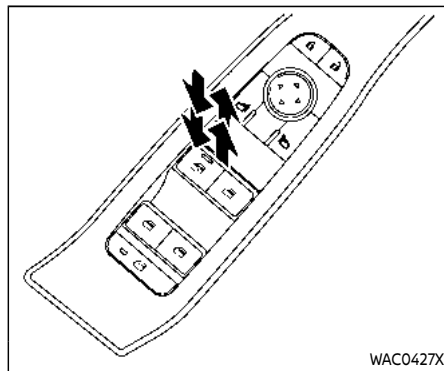

WAC0427X

Automatic operation (driver's side)

The automatic function enables a window to fully open or close without holding the switch down or up.

To fully open the window, push the power window switch down to the second detent and release the switch. To fully close the window, pull the power window switch up to the second detent and release the switch. The switch does not have to be held during window operation.

To stop the window open/close operation during the automatic function, push down or pull up the switch in opposite directions.

Auto-reverse function (driver's side)



WARNING

There are some small distances immediately before the closed position which cannot be detected. Make sure that all passengers have their hands, etc., inside the vehicle before closing the window.

The auto-reverse function enables a window to automatically reverse when something is caught in the window as it is closing by the automatic function. When the control unit detects an obstacle, the window will be lowered immediately.

Depending on the environment or driving conditions, the auto-reverse function may activate if an impact or load similar to something being caught in the window occurs.

Window timer:

The window timer allows the window switch to be operated for a short time even if the ignition switch is placed in the OFF position. The window timer will be cancelled when the driver's or front passenger's side door is opened or the preset time has expired.

When power window switch does not operate

If the power window automatic function does not operate properly, perform the following procedure to initialize the power window functions.

1. Close the door.
2. Place the ignition switch in the ON position.
3. Pull the power window switch and hold it to fully close the window.*1
4. Release the power window switch.
5. Pull the power window switch and hold it for approximately 5 seconds or more.*2
6. Push the power window switch down and hold it to fully open the window.
7. Release the power window switch.
8. Push the power window switch down and hold it for approximately 5 seconds or more.*2
9. Pull the power window switch and hold it to fully close the window.*1
10. Operate the window by the automatic function (window open and close) to confirm that the initialization is complete.

*1: If the window stops before reaching the fully closed position, release the

switch, then pull and hold it again to fully close the window.

*2: After pulling or pushing the power window switch and holding it for approximately 5 seconds or more, the window will move again.

If the window cannot automatically be closed since the auto-reverse function activated due to a malfunction, perform the following procedure to cancel the auto-reverse function.

1. Pull the power window switch up until the auto-reverse function is activated, then the window will reverse automatically.
2. Repeat the procedure twice.
3. Pull the power window switch and hold it to close the window to confirm that the cancellation is completed.



WARNING

When the auto-reverse function is canceled, the window will not automatically reverse even if the control unit detects an obstacle. Make sure that all passengers have their hands, etc. inside the vehicle before closing the windows.

MOONROOF (if so equipped)

If the power window functions do not operate properly after performing the procedure above, have your vehicle checked by a NISSAN dealer.

WARNING

- In an accident you could be thrown from the vehicle through an open moonroof. Always use seat belts and child restraints.
- Do not allow anyone to stand up or extend any portion of their body out of the moonroof opening while the vehicle is in motion or while the moonroof is closing.

CAUTION

- Remove water drops, snow, ice or sand from the moonroof before opening.
- Do not place any heavy object on the moonroof or surrounding area.

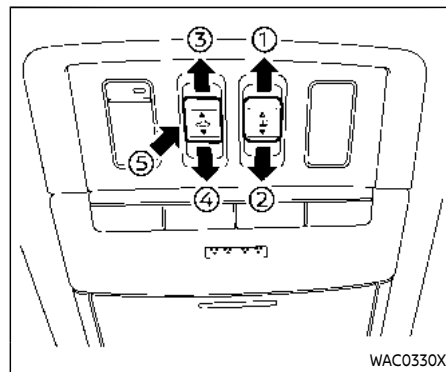

AUTOMATIC MOONROOF AND SUNSHADE

Sliding sunshade and moonroof

When the sunshade switch is pushed to the OPEN position ①, the sunshade opens. (If the sunshade starts to open from the position between close and half open, the sunshade will stop half. When the switch is pushed again, the sunshade will open fully.) When the moonroof switch is pushed to the OPEN position ③, the moonroof opens to the comfort mode position. (If the sunshade is close, the sunshade will open half first. When the switch is pushed again, the moonroof will open fully.)

When the moonroof switch is pushed to the CLOSE position ④, the moonroof will automatically close. When the sunshade switch is pushed to the CLOSE position ②, the sunshade will close. (If the sunshade starts to close from the position between full and half open, the sunshade will stop half. When the switch is pushed again, the sunshade will close fully. However, if the moonroof is open or tilted up, the sunshade will not close beyond half.)

To stop the sunshade or moonroof during the operation, push the moonroof switch to either of the OPEN ①, ③, CLOSE ②, ④ or UP ⑤ position.

Tilting moonroof

To tilt up the moonroof, push the moonroof switch to the up position ⑤.

To tilt down the moonroof, push the switch to the CLOSE position ④.

Comfort mode

This is the position used when driving with the moonroof open. When driving with the moonroof fully open, wind noise may be very loud. Use the comfort mode position when driving.

Auto-reverse function



WARNING

There are some small distances just before the closed position which cannot be detected. Make sure that all passengers have their hands, etc. inside the vehicle before closing the moonroof and sunshade.

The auto-reverse function enables the moonroof and sunshade to automatically reverse when something is caught in the moonroof and sunshade as it is closing. When the control unit detects an obstacle, the moonroof and sunshade will open immediately.

Depending on the environment or driving conditions, the auto-reverse function may activate if an impact or load similar to something being caught in the moonroof and sunshade occurs.

If the auto-reverse function activates consecutively or the battery is discharged, the moonroof and sunshade may not close properly. In this case, push and hold the switch to the CLOSE position ④ to close the moonroof.

If the moonroof does not operate

If the moonroof and sunshade do not operate properly, perform the following procedure to initialize the operation system.

1. If the moonroof and sunshade are open, close them fully by repeatedly pushing the moonroof switch to the CLOSE ② and ④ position.
2. Push and hold the moonroof switch to the CLOSE ④ position for 10 seconds.
3. After the moonroof and sunshade move slightly to the closed position and then move back a little, release the moonroof switch.
4. Push and hold the moonroof switch to the CLOSE ④ position, and the glass and shade will move.
5. Release the moonroof switch. Then the moonroof and sunshade will fully open and then fully close.
6. Check if the moonroof switch operates normally.



WARNING

The driver is always responsible for operating the moonroof properly, including the operation by all passengers. Failure to follow the warn-

ings and instructions for proper use of the moonroof could result in serious injury or death.

- Do not allow children to operate the moonroof. Improper operation by children may cause an accident. If children or others get caught in the moonroof, it could cause serious injury.
- To help avoid risk of injury or death through unintended operation of the moonroof, place the ignition switch in the OFF position when leaving the vehicle, and do not leave children and the Intelligent Key inside the vehicle.
- Do not activate the auto-reverse function intentionally. If hands or face, etc. get caught in the moonroof, it could cause serious injury.



CAUTION

- Do not place objects (such as newspapers, handkerchiefs, etc.) on the sunshade when it is extending or retracting causing improper operation or damage to the sunshade.

- Do not push the sunshade arm with your hands, etc., as this may deform it. Improper operation or damage to the sunshade may result.
- Do not put any object into the sunshade inlet port as this may result in improper operation or damage the sunshade.
- Do not hang any object on the arm rail as this may result in improper operation or damage the sunshade.
- Do not forcefully pull the sunshade. Doing so may elongate the sunshade. Improper operation or damage to the sunshade may result.

If the moonroof does not operate properly after performing the procedure above, have your vehicle checked by a NISSAN dealer.

INTERIOR LIGHTS



CAUTION

- Do not leave the light switch on when the engine is not running for extended periods of time to prevent the battery from being discharged.
- Turn off the lights when you leave the vehicle.

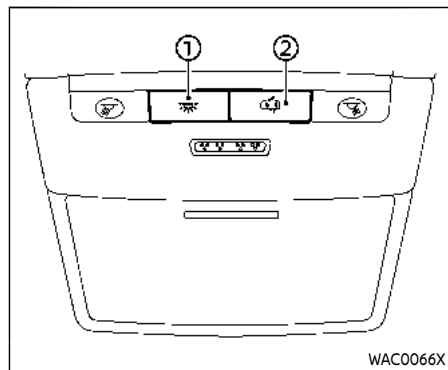

INTERIOR LIGHT SWITCH

- ① The interior light can be turned ON regardless of door position. The light will go off after a period of time unless the ignition switch is placed in the ON position when any door is opened.
- ② The interior lights can be set to operate when the doors are opened. To turn off the interior lights when a door is open, push the switch, the interior lights will not illuminate, regardless of door position. The lights will go off when the ignition switch is placed in the ON position, or the driver's door is closed and locked.

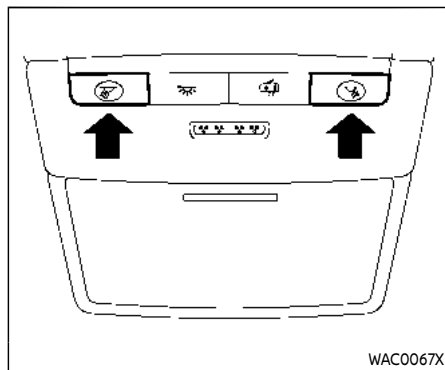

MAP LIGHTS

Push the button to turn the map lights on. To turn them off, push the button again.

The lights will also turn off after a period of time when the lights remain illuminated to prevent the battery from becoming discharged.

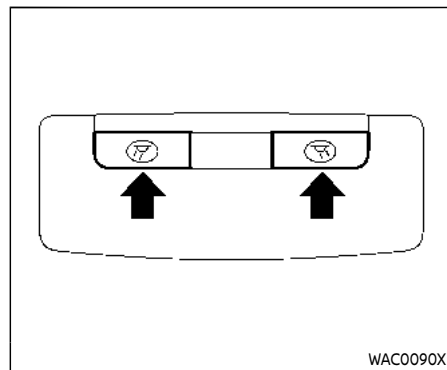

ROOM LIGHTS (if so equipped)

Push the button to turn the room lights on. To turn them off, push the button again.

The lights will also turn off after a period of time when the lights remain illuminated to prevent the battery from becoming discharged.

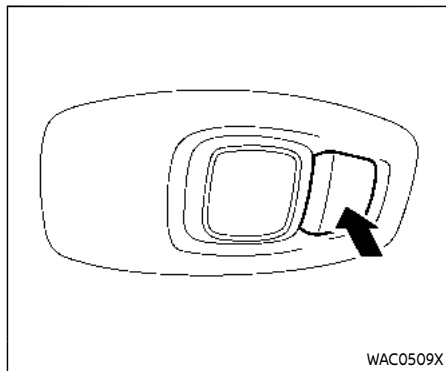

REAR PERSONAL LIGHTS (if so equipped)

To turn the rear personal lights on, push the button. To turn them off, push the button again.

The lights will also turn off after a period of time when the lights remain illuminated to prevent the battery from becoming discharged.

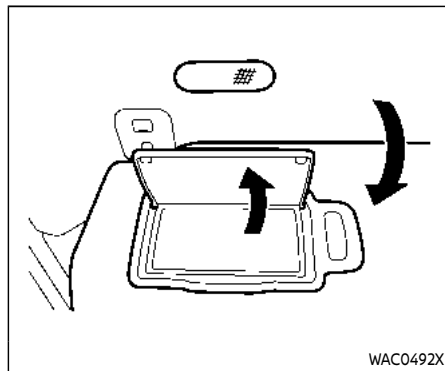

VANITY MIRROR LIGHT

The light over the vanity mirror will turn on when the cover on the vanity mirror is opened.

When the cover is closed, the light will turn off.

The lights will also turn off after a period of time when the lights remain illuminated to prevent the battery from becoming discharged.

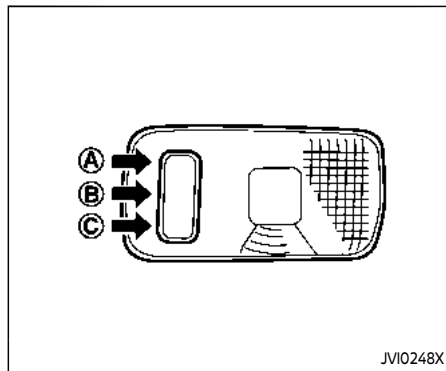

CARGO LIGHT

The cargo light has a three-position switch.

ON position

When the cargo light switch is in the ON position (A), the cargo light illuminates, regardless of any condition.

DOOR position

When the cargo light switch is in the DOOR position (B), the cargo light illuminates when the liftgate is opened.

OFF position

When the cargo light switch is in the OFF position (C), the cargo light does not illuminate, regardless of any condition.

The light will also turn off after a period of time when the light remains illuminated to prevent the battery from becoming discharged.

MEMO

3 Pre-driving checks and adjustments

Keys	3-3	Hood	3-22
Intelligent Key	3-3	Liftgate	3-23
Doors	3-5	Operating manual liftgate (if so equipped)	3-23
Locking with key	3-5	Operating power liftgate (if so equipped)	3-24
Locking with inside lock knob	3-6	Motion-activated liftgate (if so equipped)	3-26
Locking with power door lock switch	3-6	Garage mode system (if so equipped)	3-27
Automatic door locks	3-7	Auto closure (if so equipped)	3-28
Child safety rear door lock	3-7	liftgate release lever	3-28
Intelligent Key system	3-7	Fuel-filler door	3-29
Intelligent Key operating range (models with request switch)	3-9	Opening the fuel-filler door	3-29
Door locks/unlocks precaution (models with request switch)	3-10	How to refuel	3-29
Intelligent Key operation (models with request switch)	3-11	When refueling from a portable fuel container	3-30
Battery saver system	3-12	Tilt/telescopic steering	3-31
Warning lights and audible reminders	3-12	Tilt and telescopic operation	3-31
Troubleshooting guide	3-13	Sun visors	3-32
How to use remote keyless entry function	3-15	Rear sunshade (if so equipped)	3-32
Remote engine start (if so equipped)	3-19	Mirrors	3-33
Remote engine start operating range	3-20	Inside mirror	3-33
Remote starting the engine	3-20	Outside mirrors	3-35
Extending engine run time	3-20	Vanity mirror	3-36
Canceling a remote engine start	3-21	Memory seat (if so equipped)	3-37
Conditions the remote engine start will not work	3-21	Memory storage function	3-37

Entry/Exit function 3-38

System operation 3-39

KEYS

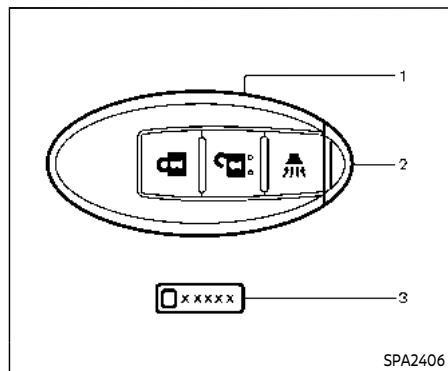

Type A (if so equipped)

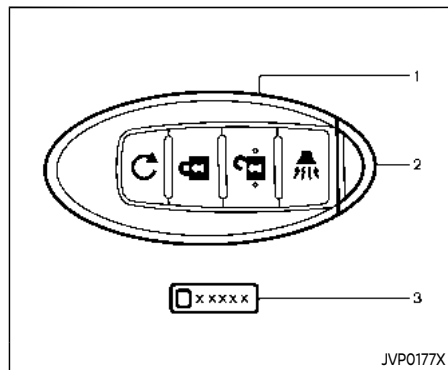

Type B (if so equipped)

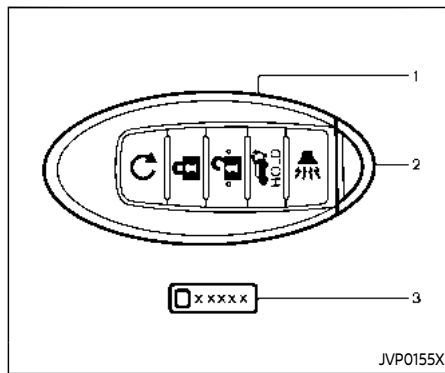

Type C (if so equipped)

1. Intelligent Key (2 sets)
2. Mechanical key (inside Intelligent Key) (2 sets)
3. Key number plate

INTELLIGENT KEY

Your vehicle can only be driven with the Intelligent Keys which are registered to your vehicle's Intelligent Key system components and NISSAN Vehicle Immobilizer System components. As many as 4 Intelligent Keys can be registered and used with one vehicle. The new keys must be registered by a NISSAN dealer prior to use with the Intelligent Key system and NISSAN Vehicle Immobilizer System of your vehicle. Since the registration pro-

cess requires erasing all memory in the Intelligent Key components when registering new keys, be sure to take all Intelligent Keys that you have to the NISSAN dealer.

A key number plate is supplied with your keys. Record the key number and keep it in a safe place (such as your wallet), not in the vehicle. If you lose your keys, it is recommended you visit a NISSAN dealer for duplicates by using the key number. NISSAN does not record any key numbers so it is very important to keep track of your key number plate.

A key number is only necessary when you have lost all keys and do not have one to duplicate from. If you still have a key, it can be duplicated without knowing the key number.

CAUTION

- **Be sure to carry the Intelligent Key with you when driving. The Intelligent Key is a precision device with a built-in transmitter. To avoid damaging it, please note the following.**
 - **The Intelligent Key is water resistant; however, wetting may damage the Intelligent**

Key. If the Intelligent Key gets wet, immediately wipe until it is completely dry.

- **Do not bend, drop or strike it against another object.**
- **If the outside temperature is below 14°F (-10°C) degrees, the battery of the Intelligent Key may not function properly.**
- **Do not place the Intelligent Key for an extended period in a place where temperatures exceed 140°F (60°C).**
- **Do not change or modify the Intelligent Key.**
- **Do not use a magnet key holder.**
- **Do not place the Intelligent Key near an electric appliance such as a television set, personal computer or cellular phone.**
- **Do not allow the Intelligent Key to come into contact with water or salt water, and do not wash it in a washing machine. This could affect the system function.**

If an Intelligent Key is lost or stolen, NISSAN recommends erasing the ID code of that Intelligent Key. This will prevent the Intelligent Key from unauthorized use to unlock the vehicle. For information regarding the erasing procedure, it is recommended you visit a NISSAN dealer.

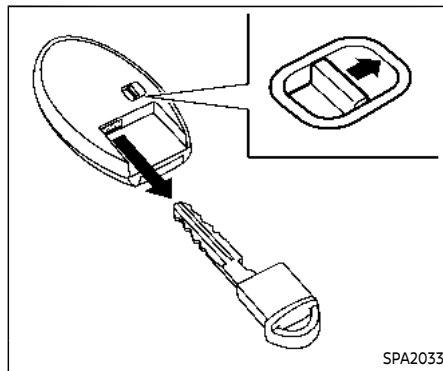

Mechanical key

To remove the mechanical key, release the lock knob at the back of the Intelligent Key.

To install the mechanical key, firmly insert it into the Intelligent Key until the lock knob returns to the lock position.

Use the mechanical key to lock or unlock the driver's door. (See "Doors" (P.3-5).)

DOORS

CAUTION

Always carry the mechanical key installed in the Intelligent Key.

WARNING

- Always have the doors locked while driving. Along with the use of seat belts, this provides greater safety in the event of an accident by helping to prevent persons from being thrown from the vehicle. This also helps keep children and others from unintentionally opening the doors, and will help keep out intruders.
- Before opening any door, always look for and avoid oncoming traffic.
- To help avoid risk of injury or death through unintended operation of the vehicle and or its systems, including entrapment in windows or inadvertent door lock activation, do not leave children, people who require the assistance of others or pets unattended in your vehicle. Additionally, the temperature inside a closed vehicle on a warm day can quickly become high enough to cause a significant risk of injury or death to people and pets.

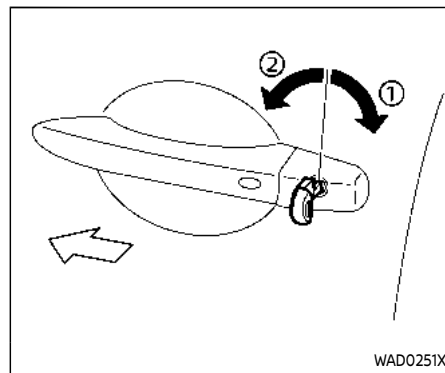

LOCKING WITH KEY

To lock the driver's door, turn the driver's door key cylinder to the rear of the vehicle ①.

To unlock the driver's door, turn the driver's door key cylinder to the front of the vehicle ②.

To lock or unlock the other doors and the liftgate, use the Intelligent Key function. (See "Intelligent Key system" (P.3-7).)

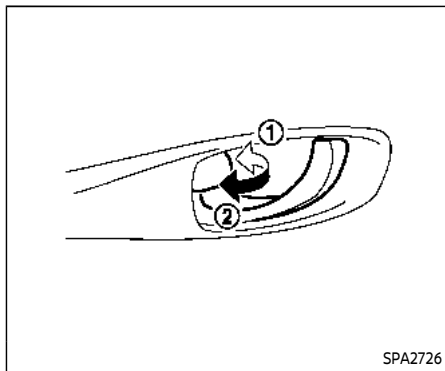

Example

SPA2726

LOCKING WITH INSIDE LOCK KNOB

To lock the door without the key, move the inside lock knob to the lock position ① then close the door.

To unlock, move the inside lock knob to the unlock position ②.

To unlock and open the front door without using the lock knob, pull once on the door handle to unlock it, and again to open it.

When locking the door without a key, be sure not to leave the key inside the vehicle.

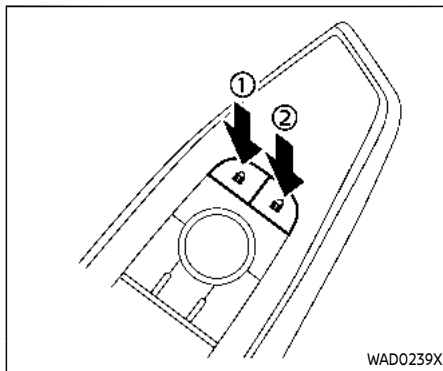

Driver's armrest

WAD0239X

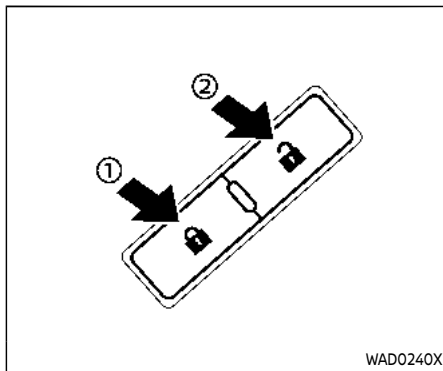

Front passenger's armrest

WAD0240X

LOCKING WITH POWER DOOR LOCK SWITCH

Operating the power door lock switch (located on the driver's and front passenger's doors) will lock or unlock all the doors.

To lock the doors, push the power door lock switch to the lock position ① with the driver's and front passenger's doors open, then close the door.

When locking the door this way, be sure not to leave the key inside the vehicle.

To unlock the doors, push the power door lock switch to the unlock position ②.

Lockout protection

Lockout protection function helps to prevent the keys from being accidentally locked inside the vehicle.

When the power door lock switch (driver's or front passenger's side) is moved to the lock position with the Intelligent Key left in the vehicle and any door open, all doors will unlock automatically and a chime will sound after the door is closed.

INTELLIGENT KEY SYSTEM

AUTOMATIC DOOR LOCKS

- All doors lock automatically when the vehicle speed reaches 15 MPH (24 km/h).
- All doors unlock automatically when the ignition switch is placed in the OFF position or when the shift position is placed in the P (Park) position, if selected.

NOTE:

The Automatic door unlock feature can be changed using the "Vehicle Settings" menu on the vehicle information display. (See "Vehicle Settings" (P.2-28).)

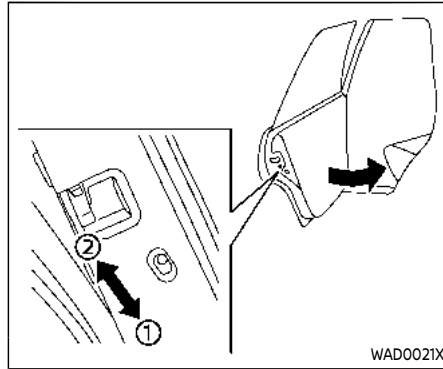

CHILD SAFETY REAR DOOR LOCK

Child safety rear door locks help prevent the rear doors from being opened accidentally, especially when small children are in the vehicle.

When the levers are in the lock position ①, the rear doors can be opened only from the outside.

To disengage, move the levers to the unlock position ②.



WARNING

- Radio waves could adversely affect electric medical equipment. Those who use a pacemaker should contact the electric medical equipment manufacturer for the possible influences before use.
- The Intelligent Key transmits radio waves when the buttons are pushed. The FAA advises that the radio waves may affect aircraft navigation and communication systems. Do not operate the Intelligent Key while on an airplane. Make sure the buttons are not operated unintentionally when the unit is stored during a flight.

The Intelligent Key system can operate all the door locks using the remote controller function or pushing the request switch (if so equipped) on the vehicle without taking the key out from a pocket or purse. The operating environment and/or conditions may affect the Intelligent Key system operation.

Be sure to read the following before using the Intelligent Key system.

Pre-driving checks and adjustments 3-7



CAUTION

- **Be sure to carry the Intelligent Key with you when operating the vehicle.**
- **Never leave the Intelligent Key in the vehicle when you leave the vehicle.**

The Intelligent Key is always communicating with the vehicle as it receives radio waves. The Intelligent Key system transmits weak radio waves. Environmental conditions may interfere with the operation of the Intelligent Key system under the following operating conditions.

- When operating near a location where strong radio waves are transmitted, such as a TV tower, power station and broadcasting station.
- When in possession of wireless equipment, such as a cellular phone, transceiver, and CB radio.
- When the Intelligent Key is in contact with or covered by metallic materials.
- When any type of radio wave remote control is used nearby.
- When the Intelligent Key is placed near an electric appliance such as a personal computer.

- When the vehicle is parked near a parking meter.

In such cases, correct the operating conditions before using the Intelligent Key function or use the mechanical key.

Although the life of the battery varies depending on the operating conditions, the battery's life is approximately 2 years. If the battery is discharged, replace it with a new one.

When the Intelligent Key battery is low, an indicator illuminates in the vehicle information display. (See "4. Key Battery Low warning" (P.2-35).)

Since the Intelligent Key is continuously receiving radio waves, if the key is left near equipment which transmits strong radio waves, such as signals from a TV and personal computer, the battery life may become shorter.

For information regarding replacement of a battery, see "Intelligent Key battery replacement" (P.8-24).

As many as 4 Intelligent Keys can be registered and used with one vehicle. For information about the purchase and use of additional Intelligent Keys, it is recommended that you contact a NISSAN dealer.



CAUTION

- **Do not allow the Intelligent Key, which contains electrical components, to come into contact with water or salt water. This could affect the system function.**
- **Do not drop the Intelligent Key.**
- **Do not strike the Intelligent Key sharply against another object.**
- **Do not change or modify the Intelligent Key.**
- **Wetting may damage the Intelligent Key. If the Intelligent Key gets wet, immediately wipe until it is completely dry.**
- **If the outside temperature is below 14°F (-10°C) degrees, the battery of the Intelligent Key may not function properly.**
- **Do not place the Intelligent Key for an extended period in an area where temperatures exceed 140°F (60°C).**
- **Do not attach the Intelligent Key with a key holder that contains a magnet.**
- **Do not place the Intelligent Key near equipment that produces a**

magnetic field, such as a TV, audio equipment, personal computers, cellular phone or wireless charger.

If an Intelligent Key is lost or stolen, NISSAN recommends erasing the ID code of that Intelligent Key from the vehicle. This may prevent the unauthorized use of the Intelligent Key to operate the vehicle. For information regarding the erasing procedure, it is recommended that you contact a NISSAN dealer.

For models with request switch: The Intelligent Key function can be disabled. For information about disabling the Intelligent Key function, it is recommended that you contact a NISSAN dealer.

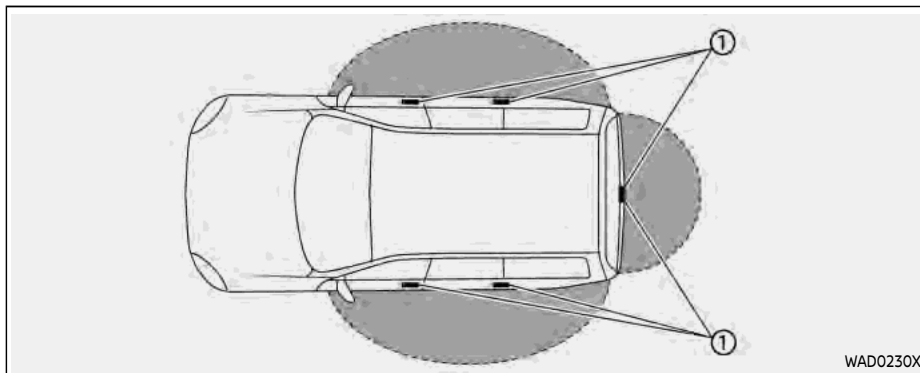

WAD0230X

INTELLIGENT KEY OPERATING RANGE (models with request switch)

The Intelligent Key functions can only be used when the Intelligent Key is within the specified operating range from the request switch ①.

When the Intelligent Key battery is discharged or strong radio waves are present near the operating location, the Intelligent Key system's operating range becomes narrower, and the Intelligent Key may not function properly.

The operating range is within 31.50 in (80 cm) from each request switch ①.

If the Intelligent Key is too close to the door glass, handle or rear bumper, the request switches may not function.

When the Intelligent Key is within the operating range, it is possible for anyone who does not carry the Intelligent Key to push the request switch to lock/unlock the doors including the liftgate.

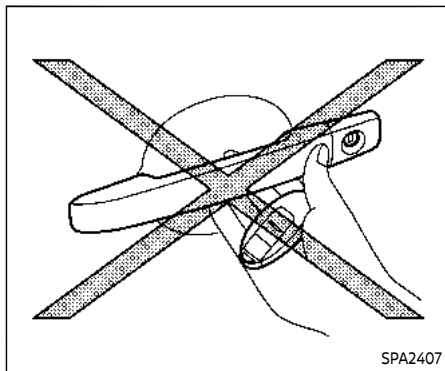

- Do not pull the door handle before pushing the door handle request switch.

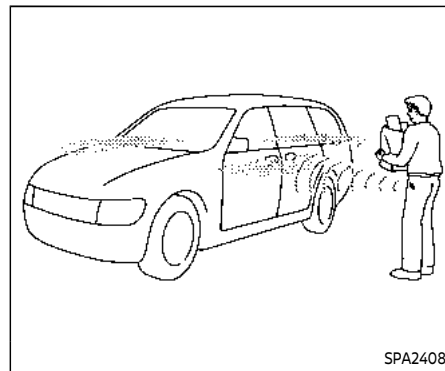

DOOR LOCKS/UNLOCKS PRECAUTION (models with request switch)

- Do not push the door handle request switch with the Intelligent Key held in your hand as illustrated. The close distance to the door handle will cause the Intelligent Key system to have difficulty recognizing that the Intelligent Key is outside the vehicle.
- After locking with the door handle request switch, verify the doors are securely locked by testing them.
- To prevent the Intelligent Key from being left inside the vehicle, make sure you carry the key with you and then lock the doors.

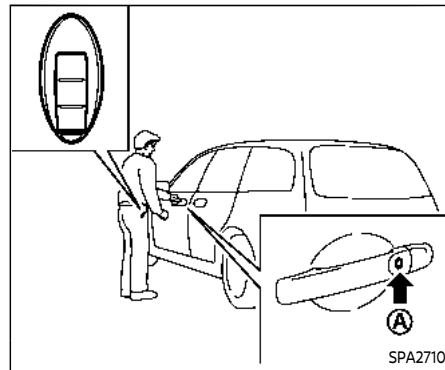

Example

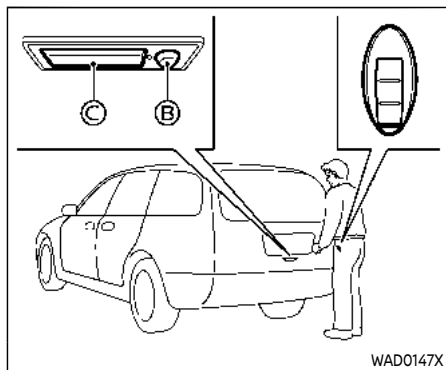

Example

INTELLIGENT KEY OPERATION (models with request switch)

You can lock or unlock the doors without taking the key out from your pocket or bag.

When you carry the Intelligent Key with you, you can lock or unlock all doors by pushing the door handle request switch Ⓐ (located on the front and rear doors) or liftgate request switch Ⓑ within the range of operation.

When you lock or unlock the doors, the hazard indicator will flash and the outside chime will sound as a confirmation. For details, see "Setting hazard indicator and

horn mode" (P.3-18).

Welcome light function

When you unlock the doors or the liftgate, the daytime running lights, parking lights and the tail lights will illuminate for a period of time. The welcome light function can be disabled. For information about disabling the welcome light function, see "Vehicle Settings" (P.2-28).

Locking doors

1. Push the park button to engage the P (Park) position. Place the ignition switch in the OFF position and make sure you carry the Intelligent Key with you.
2. Close all doors.
3. Push the door handle request switch Ⓐ or the liftgate request switch Ⓑ while carrying the Intelligent Key with you.
4. All doors and the liftgate will lock.
5. The hazard indicator lights flash twice and the outside buzzer sounds twice.

NOTE:

- **Request switches for all doors can be deactivated when the "Ext. Door Switch" is turned off in the Vehicle Settings of the vehicle information display. For additional information,**

see "Vehicle Settings" (P.2-28).

- **Doors lock with the door handle request switch while the ignition switch is not in the OFF position.**
- **Doors do not lock by pushing the driver's door handle request switch while the driver's door is open. However, doors lock with the mechanical key even if any door is open.**
- **Doors do not lock with the door handle request switch with the Intelligent Key inside the vehicle and a beep sounds to warn you. However, when an Intelligent Key is inside the vehicle, doors can be locked with another Intelligent Key.**



CAUTION

- **After locking the doors using the request switch, make sure that the doors have been securely locked by operating the door handles or the liftgate opener switch.**
- **When locking the doors using the request switch, make sure to have the Intelligent Key in your possession before operating the request switch to prevent the Intelligent Key from being left in**

the vehicle.

- **The request switch is operational only when the Intelligent Key has been detected by the Intelligent Key system.**

Unlocking doors

1. Push the door handle request switch ④ or the liftgate request switch ⑤ while carrying the Intelligent Key with you.
2. The hazard indicator flashes once and outside chime sounds once.
 - When the driver's door handle request switch or the liftgate request switch is pushed:

The corresponding door or the liftgate will unlock.

- When the other door handle request switch is pushed:
All doors and the liftgate will unlock.
3. Push the driver's door handle request switch or the liftgate request switch again within 1 minute.
 4. The hazard indicator flashes once and outside chime sounds once again. All the doors and the liftgate will unlock.

All doors will be locked automatically unless one of the following operations is

performed within 1 minute after pushing the request switch while the doors are locked.

- Opening any door.
- Pushing the ignition switch.

During this 1-minute time period, if the UNLOCK  button on the Intelligent Key is pushed, all doors will be locked automatically after another 1 minute.

NOTE:

The unlocking operation can be changed in "Selective Unlock" under the Vehicle Settings of the vehicle information display. For additional information, see "Vehicle Settings" (P.2-28).

Opening liftgate

1. Carry the Intelligent Key.
2. Push the liftgate opener switch ⑥.
3. The liftgate will unlock and then open.

BATTERY SAVER SYSTEM

When all the following conditions are met for a period of time, the battery saver system will cut off the power supply to prevent battery discharge.

- The ignition switch is in the ON position. (See "Push-button ignition switch positions" (P.5-16).)

WARNING LIGHTS AND AUDIBLE REMINDERS

To help prevent the vehicle from moving unexpectedly by erroneous operation of the Intelligent Key listed on the following chart or to help prevent the vehicle from being stolen, chime or beep sounds inside and outside the vehicle and the warning display appears on the vehicle information display.

When a chime or beep sounds or the warning display appears, be sure to check the vehicle and Intelligent Key.

See "Troubleshooting guide" (P.3-13) and "Vehicle information display" (P.2-22).

TROUBLESHOOTING GUIDE

Verify the location of all Intelligent Keys that are programmed for the vehicle. If another Intelligent Key is in range or inside the vehicle, the vehicle system may respond differently than expected.

	Symptom	Possible cause	Action to take
When stopping the engine	The Shift to P range warning appears on the display and the inside warning chime sounds continuously.	The shift position is not in the P (Park) position.	Push the park button to engage the P (Park) position.
	"No Key Press and Hold to Stop Engine" message appears on the display.	The Intelligent Key is not inside the vehicle.	Carry the Intelligent Key inside the vehicle and push the ignition switch once to stop the engine.
		There is not the Intelligent Key or the battery charge is low.	Rapidly push the ignition switch 3 consecutive times or push and hold the ignition switch for more than 2 seconds to stop the engine.
When opening the driver's door to get out of the vehicle	The door/liftgate open warning appears on the display.	The ignition switch is in the ON position.	Place the ignition switch in the OFF position.
When closing the door after getting out of the vehicle	The No Key Detected warning appears on the display, the outside chime sounds three times and the inside warning chime sounds for approximately 3 seconds.	The engine is running.	Place the ignition switch in the OFF position.
	The Rear Door Alert warning message appears on the display, the horn sounds three times, pauses, and sounds three more times, or a Check Rear Seat for All Articles warning appears on the display.	The Rear Door Alert is activated.	Check the rear seat for all articles, clear the Rear Door Alert warning message by using the steering switches.
When pushing the door handle request switch (if so equipped)	The outside chime sounds for approximately 3 seconds.	The Intelligent Key is inside the vehicle.	Carry the Intelligent Key with you.
When pushing the ignition switch to start the engine	The Key Battery Low warning appears on the display.	The Intelligent Key battery charge is low.	Replace the battery with a new one. (See "Intelligent Key battery replacement" (P.8-24).)

	Symptom	Possible cause	Action to take
When pushing the ignition switch	The Key System Error warning appears on the display.	It warns of a malfunction with the Intelligent Key system.	It is recommended that you contact a NISSAN dealer.

HOW TO USE REMOTE KEYLESS ENTRY FUNCTION



WARNING

- Radio waves could adversely affect electric medical equipment. Those who use a pacemaker should contact the electric medical equipment manufacturer for the possible influences before use.
- The Intelligent Key transmits radio waves when the buttons are pushed. The FAA advises that the radio waves may affect aircraft navigation and communication systems. Do not operate the Intelligent Key while on an airplane. Make sure the buttons are not operated unintentionally when the unit is stored during a flight.



CAUTION

- Do not allow the Intelligent Key, which contains electrical components, to come into contact with water or salt water. This could

affect the system function.

- Do not drop the Intelligent Key.
- Do not strike the Intelligent Key sharply against another object.
- Do not change or modify the Intelligent Key.
- Wetting may damage the Intelligent Key. If the Intelligent Key gets wet, immediately wipe until it is completely dry.
- If the outside temperature is below 14°F (-10°C) degrees, the battery of the Intelligent Key may not function properly.
- Do not place the Intelligent Key for an extended period in an area where temperatures exceed 140°F (60°C).
- Do not attach the Intelligent Key with a key holder that contains a magnet.
- Do not place the Intelligent Key near equipment that produces a magnetic field, such as a TV, audio equipment, personal computers, cellular phone or wireless charger.

The remote keyless entry function can operate all door locks using the remote

keyless entry function of the Intelligent Key. The remote keyless entry function can operate at a distance of approximately 33 ft (10 m) from the vehicle. (The operating distance depends upon the conditions around the vehicle.)

The remote keyless entry function will not operate:

- When the Intelligent Key is not within the operational range.
- When the Intelligent Key battery is discharged.

The remote keyless entry function can also operate the vehicle alarm.

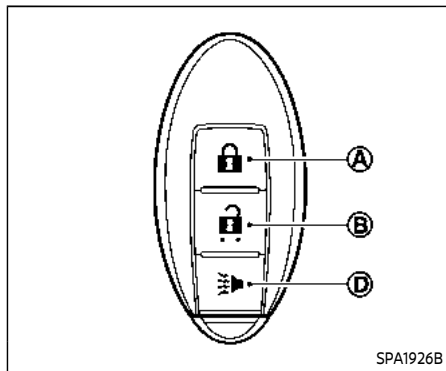

Type A (if so equipped)

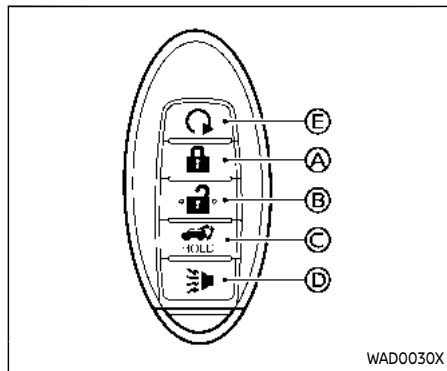

Type C (if so equipped)

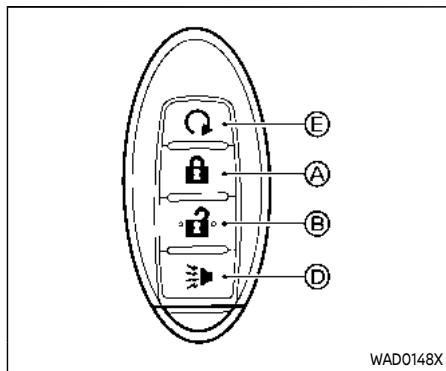

Type B (if so equipped)

- Ⓐ LOCK button
- Ⓑ UNLOCK button
- Ⓒ Power liftgate button
- Ⓓ PANIC button
- Ⓔ Remote engine start button

When you lock or unlock the doors or the liftgate, the hazard indicator will flash and the horn will sound as a confirmation. For details, see "Setting hazard indicator and horn mode" (P.3-18).

Locking doors

1. Place the ignition switch in the OFF position.
2. Carry the Intelligent Key with you.*
3. Close all the doors.
4. Push the LOCK button Ⓐ on the Intelligent Key.
5. All the doors and the liftgate will lock.
6. The hazard indicator flashes twice and the horn chirps once.

*: Doors will lock with the Intelligent Key while the ignition switch is in the ON position.

Operate the door handles to confirm that the doors have been securely locked.

Unlocking doors

1. Push the UNLOCK button Ⓑ on the Intelligent Key once.
2. The hazard indicator flashes once. The driver's door will unlock.
3. Push the UNLOCK button again within 1 minute.
4. The hazard indicator flashes once. All the doors and the liftgate will unlock.

All doors will be locked automatically unless one of the following operations is performed within 1 minute after pushing the UNLOCK button while the doors are locked.



- Opening any door (including the liftgate).
- Pushing the ignition switch.

During this 1-minute time period, if the UNLOCK  button is pushed, all doors will be locked automatically after another 1 minute.

NOTE:

The unlocking operation can be changed in “Selective Unlock” under the Vehicle Settings of the vehicle information display. For additional information, see “Vehicle Settings” (P.2-28).



Opening/closing liftgate (if so equipped)

1. Push the power liftgate button   for more than 1 second.
2. The liftgate will automatically open.

The outside chime sounds 3 times for approximately 3 seconds.

To close the liftgate, push the power liftgate button  for more than 1 second.



The liftgate will automatically close.

If the button  is pushed while the liftgate is being opened or closed, the liftgate will immediately stop. Pushing the button  again will reverse the direction of the liftgate. However, when the liftgate is near the fully open position, it



moves in the closing direction and when the liftgate is near the fully close position, it moves in the opening direction.

Using panic alarm

If you are near your vehicle and feel threatened, you may activate the alarm to call attention as follows:

1. Push the PANIC  button  on the Intelligent Key for **more than 0.5 seconds**.
2. The theft warning alarm and headlights will stay on for 25 seconds.
3. The panic alarm stops when:
 - It has run for 25 seconds, or
 - Any of the buttons on the Intelligent Key is pushed.

Remote engine start (if so equipped)

The remote engine start  button  is on the Intelligent Key if the vehicle has remote engine start function. This function allows the engine to start from outside the vehicle. See “Remote engine start” (P.3-19).

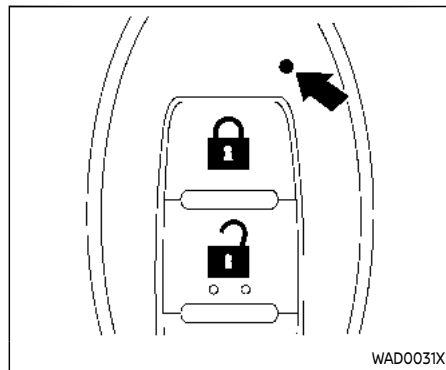





Intelligent Key button operation light

The light blinks only when you push any button on the Intelligent Key. The light illumination only signifies that the Intelligent Key has transmitted a signal. You may look and/or listen to verify that the vehicle has performed the intended operation. If the light does not blink, your battery may be too weak to communicate to the vehicle. If this occurs, the battery may need to be replaced.



For additional information regarding the replacement of a battery, see “Intelligent Key battery replacement” (P.8-24).

Setting hazard indicator and horn mode



This vehicle is set in hazard indicator and horn mode when you first receive the vehicle.

In hazard indicator and horn mode, when the LOCK  button  is pushed, the hazard indicator flashes twice and the horn chirps once. When the UNLOCK  button  is pushed, the hazard indicator flashes once.



If horns are not necessary, the system can be switched to the hazard indicator mode.

In hazard indicator mode, when the LOCK  button is pushed, the hazard indicator flashes twice. When the UNLOCK  button is pushed, neither the hazard indicator nor the horn operates.

Hazard indicator and horn mode:





Operation	DOOR LOCK	DOOR UNLOCK
Pushing door handle request switch or liftgate request switch (if so equipped)	HAZARD - twice OUTSIDE CHIME - twice	HAZARD - once OUTSIDE CHIME - once
Pushing  or  button	HAZARD - twice HORN - once	HAZARD - once HORN - none

Hazard indicator mode:

Operation	DOOR LOCK	DOOR UNLOCK
Pushing door handle request switch (if so equipped) or liftgate request switch	HAZARD - twice OUTSIDE CHIME - none	HAZARD - none OUTSIDE CHIME - none
Pushing  or  button	HAZARD - twice HORN - none	HAZARD - none HORN - none

REMOTE ENGINE START (if so equipped)

Switching procedure:

To switch the hazard indicator and horn (chime) operation, push the LOCK   and UNLOCK   buttons on the Intelligent Key simultaneously for more than 4 seconds.

- When the hazard indicator mode is set, the hazard indicator flashes 3 times.
- When the hazard indicator and horn mode is set, the hazard indicator flashes once and the horn chirps once.

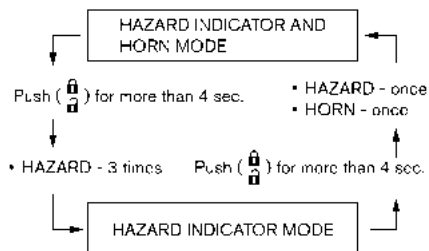

The horn operation can also be turned on or off in the vehicle information display. See "Vehicle Settings" (P.2-28).



WARNING

To avoid risk of injury or death, do not use the remote engine start function when the vehicle is in an enclosed area such as a garage.

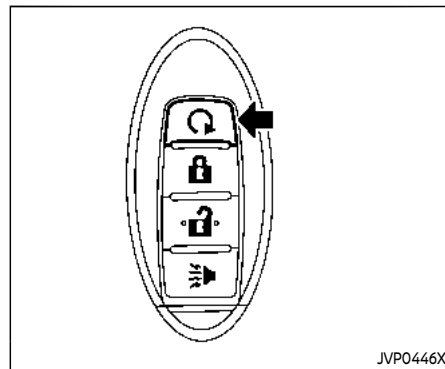

Example

The remote engine start  button is on the Intelligent Key if the vehicle has remote engine start function. This function allows the engine to start from outside the vehicle.

Some systems, such as the air conditioner system, will turn on during a remote engine start, if the system was on the last time the ignition switch was turned off.

Laws in some local communities may restrict the use of remote engine starters. For example, some laws require a person using remote engine start to have the vehicle in view. Check local regulations for any requirements.

Other conditions may affect the remote engine start function. See “Conditions the remote engine start will not work” (P.3-21).

Other conditions can affect the performance of the Intelligent Key transmitter. See “Intelligent Key system” (P.3-7) for additional information.

REMOTE ENGINE START OPERATING RANGE

The remote engine start function can only be used when the Intelligent Key is within the specified operating range from the vehicle.



When the Intelligent Key battery is discharged or other strong radio wave sources are present near the operating location, the Intelligent Key operating range becomes narrower, and the Intelligent Key may not function properly.

The remote engine start operating range is approximately 197 ft (60 m) from the vehicle.

REMOTE STARTING THE ENGINE

To use the remote start function to start the engine, perform the following:

1. If the doors are unlocked, push the LOCK  button to lock all doors.
2. Aim the Intelligent Key at the vehicle.

3. Push the LOCK  button again.
4. Within 5 seconds push and hold the remote engine start  button until the turn signal lights flash and the tail lights illuminate. If the vehicle is not within view, push and hold the remote engine start  button for at least 2 seconds.

The following events will occur when the engine starts:

- The front parking lights will turn on and remain on as long as the engine is running.
- The doors will be locked and the air conditioner system may turn on.
- The engine will continue to run for about 10 minutes. Repeat the steps to extend the time for an additional 10 minutes. See “Extending engine run time” (P.3-20).

Depress and hold the brake pedal, then place the ignition switch in the ON position before driving. For further instructions, see “Driving the vehicle” (P.5-19).

EXTENDING ENGINE RUN TIME

The remote engine start function can be extended one time by performing the steps listed in “Remote starting the engine” (P.3-20). Run time will be calculated as follows:

- The first 10 minute run time will start when the remote engine start function is performed.
- The second 10 minutes will start immediately when the remote engine start function is performed. For example, if the engine has been running for 5 minutes, and 10 minutes are added, the engine will run for a total of 15 minutes.
- Extending engine run time will count towards the two remote engine start limit.

A maximum of two remote engine starts, or a single start with an extension can be used.

The vehicle needs to be driven at speeds of 4 MPH (7 km/h) before the remote engine start procedure can be used again.



CANCELING A REMOTE ENGINE START

To cancel a remote engine start, perform one of the following:

- Aim the Intelligent Key at the vehicle and push the remote engine start  button until the front parking lights turn off.
- Turn on the hazard indicator flashers.
- Cycle the ignition switch ON and then OFF.
- The extended engine run time has expired.
- The first 10 minute timer has expired.
- The engine hood has been opened.
- The shift position is shifted out of the P (Park) position.
- The theft alarm sounds due to illegal entry into the vehicle.
- The ignition switch is pushed without an Intelligent Key in the vehicle.
- The ignition switch is pushed with an Intelligent Key in the vehicle but the brake pedal is not depressed.
- The accelerator pedal is depressed.
- The vehicle moves after a remote engine start. (The hazard indicator flashers blink once and the engine is stopped.)

CONDITIONS THE REMOTE ENGINE START WILL NOT WORK

The remote engine start will not operate if any of the following conditions are present:

- The ignition switch is placed in the ON position.
- The hood is not securely closed.
- The hazard indicator flashers are on.
- The engine is still running. The engine must be completely stopped. This is not applicable when extending engine run time.
- The remote engine start  button is not pushed and held for at least 2 seconds.
- The remote engine start  button is not pushed and held within 5 seconds of pushing the LOCK  button.
- The doors are not closed and locked. (The hazard indicator flashers blink twice to indicate the function is not operated.)
- The liftgate is open. (The hazard indicator flashers blink twice to indicate the function is not operated.)
- The Key System Error warning message remains on in the vehicle information display.

- The theft alarm sounds due to illegal entry into the vehicle. (The hazard indicator flashers blink twice to indicate the function is not operated.)
- Two remote engine starts, or a single remote engine start with an extension, have already been used. (To use the remote engine start function again, the vehicle needs to be driven at speeds of 4 MPH (7 km/h).)
- The shift position is not in the P (Park) position.

HOOD

WARNING

- Make sure the hood is completely closed and latched before driving. Failure to do so could cause the hood to fly open and result in an accident.
- Never open the hood if steam or smoke is coming from the engine compartment to avoid injury.

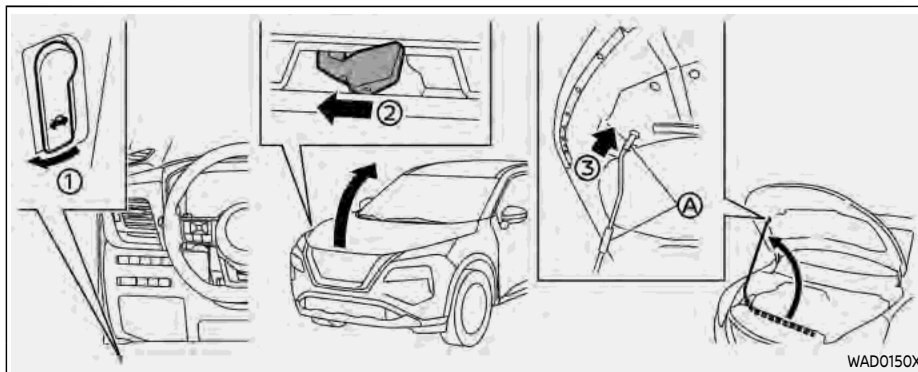

WAD0150X

1. Pull the hood lock release handle ① located below the driver's side instrument panel; the hood springs up slightly.
2. Push the lever ② underneath the front of the hood sideways as illustrated with your fingertips.
3. Raise the hood.
4. Remove the support rod and insert it into the slot ③.

Hold the coated parts ④ when removing or resetting the support rod. Avoid direct contact with the metal parts, as they may be hot immediately after the engine has been stopped.

When closing the hood:

1. While supporting the hood, return the support rod to its original position.
2. Slowly lower the hood to about 8 to 12 in (20 to 30 cm) above the hood lock, then let it drop.
3. Make sure it is securely latched.

LIFTGATE

WARNING

- Always be sure the liftgate has been closed securely to prevent it from opening while driving.
- Do not drive with the liftgate open. This could allow dangerous exhaust gases to be drawn into the vehicle. For additional information, refer to “Exhaust gas (carbon monoxide)” (P.5-5).
- To help avoid risk of injury or death through unintended operation of the vehicle and or its systems, including entrapment in windows or inadvertent door lock activation, do not leave children, people who require the assistance of others or pets unattended in your vehicle. Additionally, the temperature inside a closed vehicle on a warm day can quickly become high enough to cause a significant risk of injury or death to people and pets.
- Always be sure that hands and feet are clear of the door frame to avoid injury while closing the liftgate.

CAUTION

Do not use accessory carriers that attach to the liftgate. Doing so will cause damage to the vehicle.

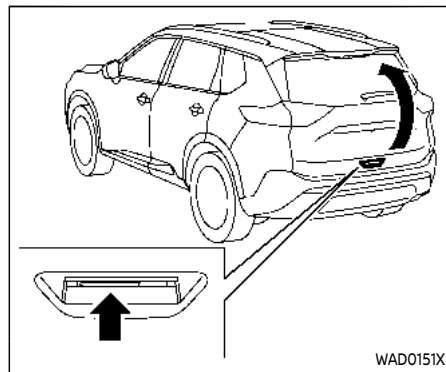

OPERATING MANUAL LIFTGATE (if so equipped)

To open the liftgate, unlock it. Pull up the liftgate to open.

The liftgate can be unlocked by:

- pushing the UNLOCK  button on the Intelligent Key twice.
- pushing the liftgate request switch (if so equipped).
- pushing the door handle request switch (if so equipped).

To close the liftgate, pull down until it securely locks.

OPERATING POWER LIFTGATE (if so equipped)

To operate the power liftgate, the vehicle must be in the P (Park) position.

The power liftgate will not operate if the battery voltage is low.

The power liftgate operation can be activated or deactivated in the vehicle information display. (See "Vehicle Settings" (P.2-28).)

NOTE:

- For models with motion-activated liftgate: When washing, waxing or maintaining your vehicle, placing or replacing the body cover, or splashing water to the area around the kick motion sensor, turn off the power liftgate.
- If the power open or close operation is performed consecutively, the safety mode activates and the operation cannot be performed for a certain period of time. In this case, wait for a while and then perform the operation.

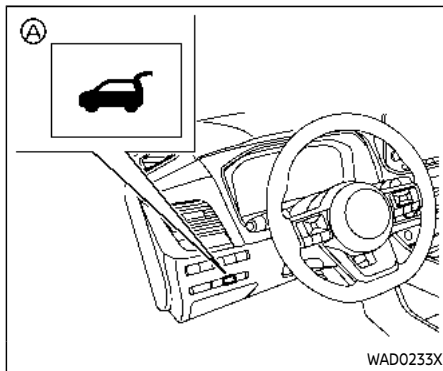

Power liftgate switch – Instrument panel

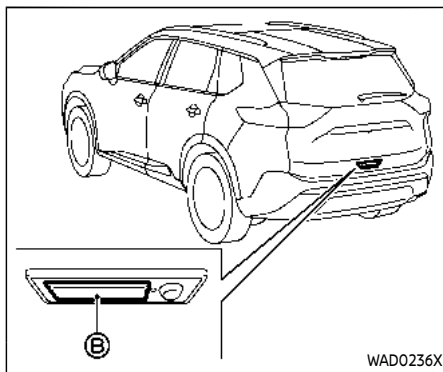

Liftgate opener switch

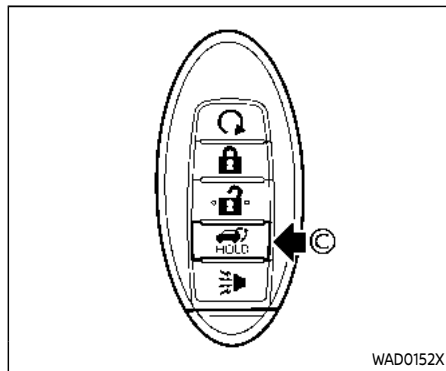

Power liftgate button - Key (example)

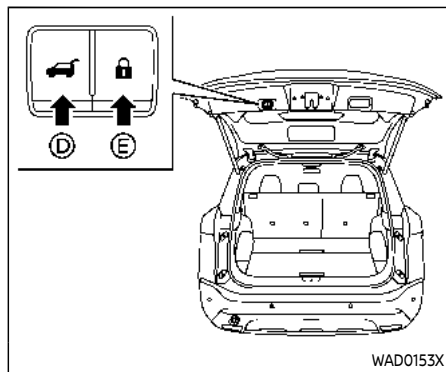

Power liftgate close and lock switches – Liftgate

Power open (using switches)

When the liftgate is fully closed, the liftgate will fully open automatically by:

- pushing the power liftgate switch **A** on the instrument panel for more than 1 second
- pushing the liftgate opener switch **B**
- pushing the power liftgate button **C** on the key for more than 1 second

The outside chime sounds when the liftgate starts opening.

NOTE:

The liftgate can be opened by the power liftgate switch **A or the power liftgate button  **C** even if the liftgate is locked. The liftgate can be unlocked and opened independently of the other doors, even when they are locked. The liftgate must be unlocked (or the Intelligent Key must be within range) to open with the liftgate opener switch **B**.**

Power close (using switches)

When the liftgate is fully opened, the liftgate will fully close automatically by:

- pushing the power liftgate switch **A** on the instrument panel for more than 1 second

- pushing the power liftgate button **C** on the key for more than 1 second
- pushing the power liftgate close switch **D** on the lower part of the liftgate for 1 second

The outside chime sounds when the liftgate starts closing.

Power close and lock

When the liftgate is fully opened and the Intelligent Key is carried with you near the liftgate, the liftgate will fully close and lock automatically by pushing the power liftgate lock switch **E** on the lower part of the liftgate.

The outside chime sounds when the liftgate starts closing.

Stop and reverse function (if so equipped)

The power liftgate will stop immediately if one of the following actions is performed during power open or close.

- pushing the power liftgate switch **A**
- pushing the liftgate opener switch **B**
- pushing the power liftgate close switch **D** on the lower part of the liftgate
- pushing the power liftgate button **C** on the key

And then the power liftgate will move in

the reverse direction if one of the above actions is performed again.

The outside chime sounds when the liftgate starts to reverse.

Auto reverse function

The auto-reverse function enables the liftgate to automatically reverse when something is caught in the liftgate as it is opening or closing. When the control unit detects an obstacle, the liftgate will reverse and return to the full open or full close position.

If a second obstacle is detected, the liftgate motion will stop. The liftgate will enter the manual mode.

A pinch sensor is mounted on each side of the liftgate. If an obstacle is detected by the pinch sensor during power close, the liftgate will reverse and return to the full open position immediately.

NOTE:

If the pinch sensor is damaged or removed, the power close function will not operate.



WARNING

There is a small distance immediately before the closed position that cannot be detected. Make sure that

all passengers keep their hands, etc., clear from the liftgate opening before closing the liftgate.

Manual mode

If power operation is not available, the liftgate can be operated manually. Power operation may not be available if multiple obstacles have been detected in a single power cycle or if the battery voltage is low. When the power liftgate is turned off, the liftgate can be opened manually by pushing the liftgate opener switch. If the power liftgate opener switch is pushed during power open or close, the power operation will be canceled and the liftgate can be operated manually. This will allow normal power operation functions to resume.

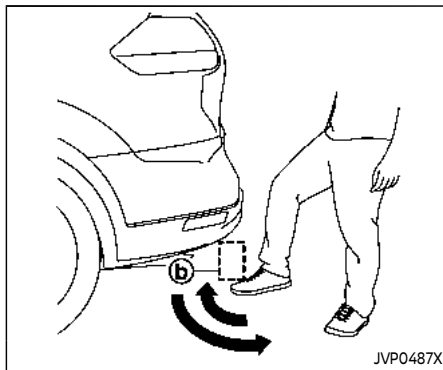
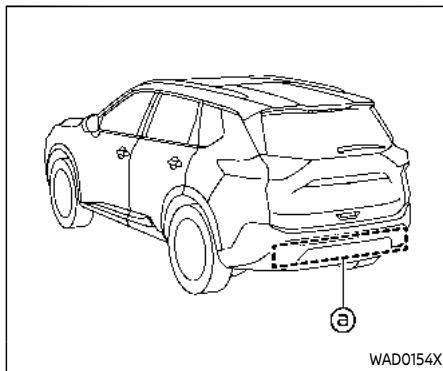

MOTION-ACTIVATED LIFTGATE (if so equipped)

The liftgate can be operated using a quick kicking motion under the center of the rear bumper.

The kick motion sensor **a** is located on the back of the rear bumper. when you move your foot under and then away from the operating range **b** similar to a kicking motion, while carrying the Intelligent Key with you, the liftgate will open or close automatically.

Proper operation technique

- While at the rear of the vehicle, begin making a quick forward kicking motion.
- Raise your foot straight under the center of the rear bumper then immediately return your foot to the ground in a continuous motion.
- You do not need to hold your foot under the bumper or move it side to side. Immediately return your foot to the ground.
- The kicking motion should be straight, smooth and consistent.
- After your kick motion is complete, step back and allow the liftgate to open/close.

- Three beeps will sound and the liftgate will begin moving within 2 seconds after the kick.



WARNING

Prevent unintentional liftgate opening/closing. There may be conditions when opening/closing the liftgate is not desired. Keep the Intelligent Key out of range of the liftgate, (7 ft (2 m) or more) or inside the vehicle, when washing or working around the back of the vehicle.

NOTE:

- The kick motion sensor may not function under the following conditions:
 - When operating near a location where strong radio waves are transmitted, such as a TV tower, power station or broadcasting station.
 - When the vehicle is parked near a parking meter.
- The power liftgate may not operate when your foot remains in the operating range .



CAUTION

- When the Intelligent Key is carried with you near the liftgate, even someone, who does not carry the Intelligent Key, may be able to open or close the liftgate with a kick motion.
- Do not perform a kick motion near the exhaust system components while they are hot. You may severely burn yourself.
- Do not perform a kick motion on an unstable place (for example, on a slope or a muddy ground, etc.).

Power open or close function

The liftgate will fully open automatically using the kick motion sensor.

1. Carry the Intelligent Key.
2. Move your foot under and away from the rear bumper similarly to a kicking motion within the operation range of the kick motion sensor.
3. The liftgate will automatically open or close.

Stop and reverse function

The power liftgate will stop immediately if a kick motion is performed during power open or close. The liftgate can be stopped even if you do not carry the Intelligent Key.

And then the power liftgate will move in the reverse direction if a kick motion is performed again. The power liftgate can be reversed when you carry the Intelligent Key.

GARAGE MODE SYSTEM (if so equipped)

The liftgate can be set to open to a specific height by performing the following:

1. Open the liftgate.
2. Pull the liftgate down to the desired position and hold the liftgate (the liftgate will have some resistance when being manually adjusted).
3. While holding the liftgate in position, press and hold the power liftgate close and lock switch  located on the liftgate for approximately 3 seconds or until 2 beeps are heard.

The liftgate will open to the selected position setting. To change the position of the liftgate, repeat steps 1-3 for setting the position of the liftgate.



CAUTION

Do not set the height of the liftgate below approximately 1/3 of the way to the floor using garage mode. Even if you set the height below approximately 1/3 of the way to the floor, the height will automatically be set to approximately 1/3 of the way to the floor.

- Do not let children operate the liftgate.

AUTO CLOSURE (if so equipped)

When the liftgate reaches the secondary position, the closure motor engages and pulls the liftgate to its primary latch position.

Do not apply excessive force when the auto closure is operating. Excessive force applied may cause the mechanism to malfunction.



CAUTION

- The liftgate will automatically close from the secondary position. To avoid pinching, keep hands and fingers away from liftgate opening.

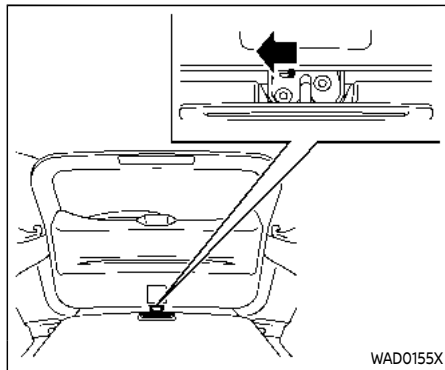

WAD0155X

LIFTGATE RELEASE LEVER

If the liftgate cannot be opened with the power door lock switch due to a discharged battery, follow these steps.

1. Fold the rear seats down. (See "Seats" (P.1-3).)
2. Insert a suitable tool in the access opening. Move the release lever to the left. The liftgate will be unlatched.
3. Push the liftgate up to open.

Contact a NISSAN dealer as soon as possible for repair.

FUEL-FILLER DOOR



CAUTION

- Avoid applying direct water pressure, such as high-pressured sprayer, on or around the fuel-filler door.
- Be sure to close the fuel-filler door before using an automatic car wash or a high-pressured car wash.

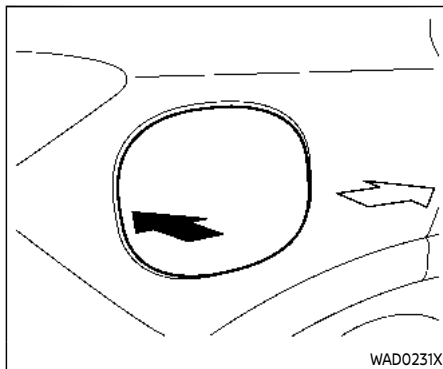

OPENING THE FUEL-FILLER DOOR

To open the fuel-filler door, push the middle left side of the door.

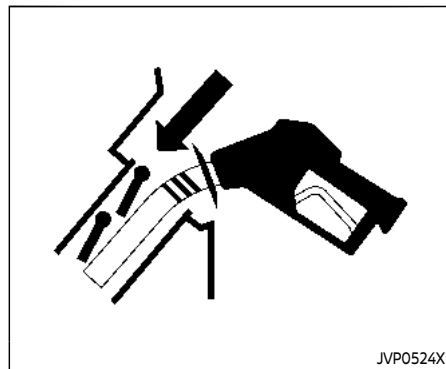

HOW TO REFUEL

The fuel tank is not equipped with a fuel-filler cap. After opening the fuel-filler door, insert the fuel pump nozzle directly into the fuel-filler opening. When the fuel pump nozzle is pulled out, the fuel-filler opening will be sealed.

To refuel:

Be sure to insert the fuel pump nozzle slowly into the fuel-filler opening as far as it will go before fueling.

Never move the nozzle during refueling.

Pull out the nozzle approximately 5 seconds after the fuel pump nozzle shuts off automatically (initial shut-off).

Close the fuel-filler door after refueling.

If you need to refuel from a portable fuel container, use the funnel supplied with your vehicle. (See "When refueling from a portable fuel container" (P.3-30).)

CAUTION

- Do not attempt to open the flaps on the fuel-filler opening using any tool other than the fuel pump nozzle.
- This fuel-filler opening is only conformable to normal fuel pump nozzles at gas stations. Using a nozzle with a small diameter may damage the opening and the fuel system.
- If fuel is spilled on the vehicle body, flush it away with water to avoid paint damage.

WARNING

- Gasoline is extremely flammable and highly explosive under certain conditions. You could be burned or seriously injured if it is misused or mishandled. Always

stop engine and do not smoke or allow open flames or sparks near the vehicle when refueling.

- Do not attempt to top off the fuel tank after the fuel pump nozzle shuts off automatically. Continued refueling may cause fuel overflow, resulting in fuel spray and possibly a fire.
- Never pour fuel into the throttle body to attempt to start your vehicle.
- Do not fill a portable fuel container in the vehicle or trailer. Static electricity can cause an explosion of flammable liquid, vapor or gas in any vehicle or trailer. To reduce the risk of serious injury or death when filling portable fuel containers:
 - Always place the container on the ground when filling.
 - Do not use electronic devices when filling.
 - Keep the pump nozzle in contact with the container while you are filling it.
 - Use only approved portable fuel containers for flammable liquid.

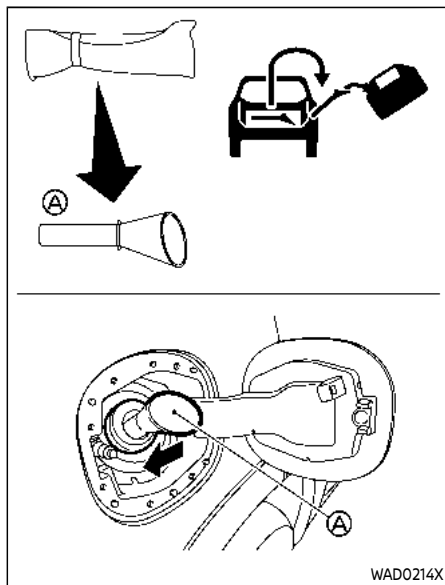

WHEN REFUELING FROM A PORTABLE FUEL CONTAINER

If you need to refuel from a portable fuel container, use the funnel (A) stored in the tool bag (located under the luggage board).

Be sure to insert the funnel into the fuel-

filler opening slowly and fully. Insert the nozzle of the portable fuel container into the opening along the funnel and fill the fuel tank.

After refueling, remove the funnel from the fuel-filler opening. Wipe the funnel clean and return it to the tool bag.

CAUTION

- Do not insert the nozzle of the portable fuel container directly into the fuel-filler opening. Doing so may damage the opening and the fuel system.
- Use only the funnel provided with your vehicle. Otherwise, the fuel-filler opening and the fuel system may be damaged.

TILT/TELESCOPIC STEERING

WARNING

- Do not adjust the steering wheel while driving. You could lose control of your vehicle and cause an accident.
- Do not adjust the steering wheel any closer to you than is necessary for proper steering operation and comfort. The driver's air bag inflates with great force. If you are unrestrained, leaning forward, sitting sideways or out of position in any way, you are at greater risk of injury or death in a crash. You may also receive serious or fatal injuries from the air bag if you are up against it when it inflates. Always sit back against the seatback and as far away as practical from the steering wheel. Always use the seat belts.

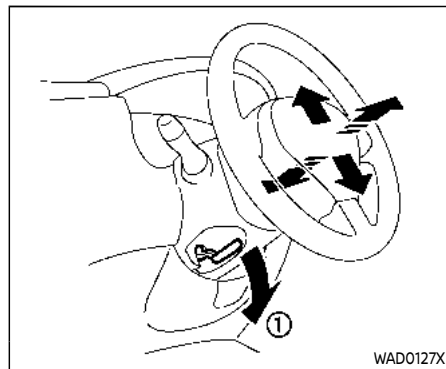

TILT AND TELESCOPIC OPERATION

Pull the lock lever ① down and adjust the steering wheel up, down, forward or rearward to the desired position. Push the lock lever up securely to lock the steering wheel in place.

SUN VISORS

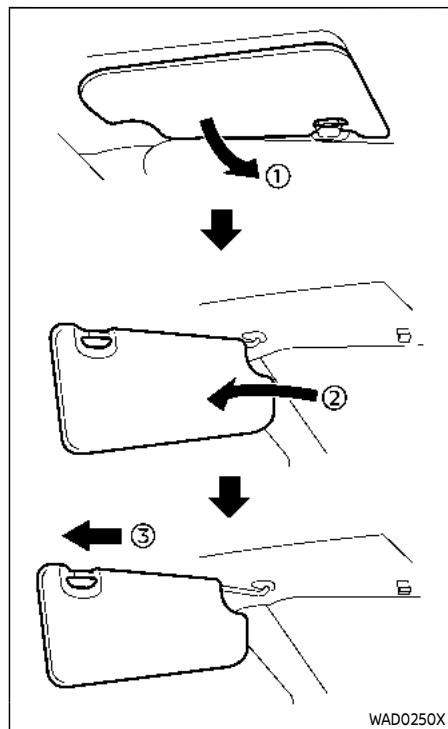

1. To block glare from the front, swing down the main sun visor ①.

2. To block glare from the side, remove the main sun visor from the center mount and swing it to the side ②.
3. Slide the sun visor ③ in or out as needed.

CAUTION

- Do not store the sun visor before returning the extension to its original position.
- Do not pull the extension sun visor forcedly downward.

REAR SUNSHADE (if so equipped)

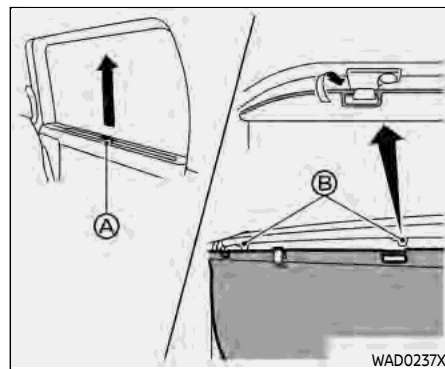

CAUTION

- Do not release the rear sunshade during operation. This could damage the sunshade or cause injury.
- Do not forcefully pull the sunshade. Doing so may elongate the sunshade. This could cause improper operation or could damage the sunshade.
- Do not place objects on or near the rear sunshade. This could cause improper operation or

MIRRORS

could damage the sunshade.

The rear sunshades are equipped on the rear seat windows.

To raise the sunshade, pull the knob ④ up and hang the sunshade on the hooks ③.

To store the sunshade, remove the sunshade from the hooks and lower it.

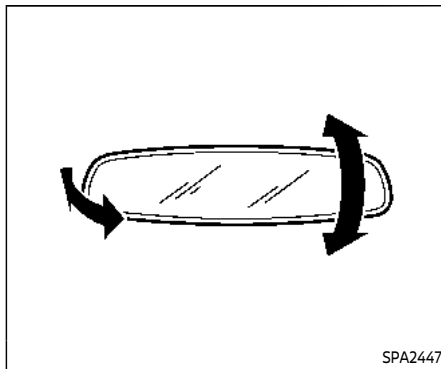

INSIDE MIRROR

Adjust the angle of the inside mirror to the desired position.

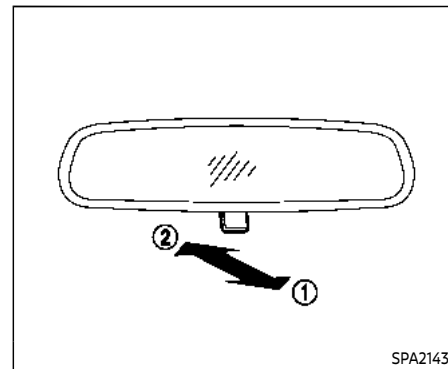

Manual anti-glare type (if so equipped)

The night position ① will reduce glare from the headlights of vehicles behind you at night.

Use the day position ② when driving in daylight hours.



WARNING

Use the night position only when necessary, because it reduces rear view clarity.

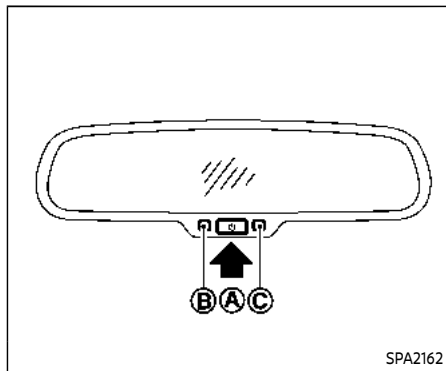

SPA2162

Automatic anti-glare type (if so equipped)

Type A (if so equipped):

The inside mirror is designed so that it automatically changes reflection according to the intensity of the headlights of the following vehicle.

The anti-glare system will be automatically turned on when the ignition switch is placed in the ON position.

When the anti-glare system is turned on, the indicator light **B** will illuminate and excessive glare from the headlights of the vehicle behind you will be reduced.

Push the  switch **A** to make the inside

rearview mirror operate normally. The indicator light will turn off. Push the  switch again to turn the system on.

Do not hang any objects on the mirror or apply glass cleaner. Doing so will reduce the sensitivity of the sensor **C, resulting in improper operation.**

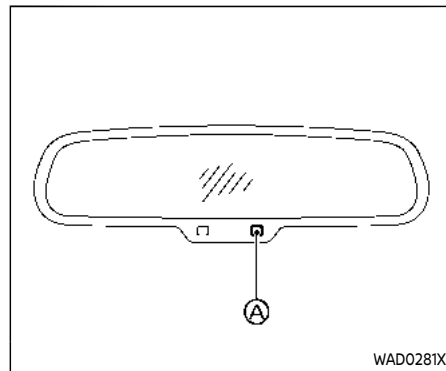

WAD0281X

Type B (if so equipped):

The inside mirror is designed so that it automatically dims during night time conditions and according to the intensity of the headlights of the following vehicle.

The anti-glare system will be automatically turned on when the ignition switch is placed in the ON position.

Do not hang any objects on the mirror or apply glass cleaner. Doing so will reduce the sensitivity of the sensor **A, resulting in improper operation.**

OUTSIDE MIRRORS

WARNING

Objects viewed in the outside mirror on the passenger side are closer than they appear. Be careful when moving to the right. Using only this mirror could cause an accident. Use the inside mirror or glance over your shoulder to properly judge distances to other objects.

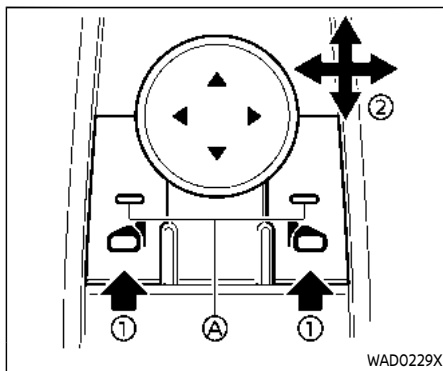

Adjusting outside mirrors

The outside mirror control switch is located on the driver's armrest.

The outside mirror will operate only when the ignition switch is in the ON position.

Push either the right or left switch to select the right or left side mirror ① (the indicator light ② on the selected mirror switch illuminates), then adjust ② using the control switch.

Defrosting outside mirrors (if so equipped)

The outside mirrors will be heated when the rear window defroster switch is operated. (See "Rear window and outside mirror defroster switch" (P.2-57).)

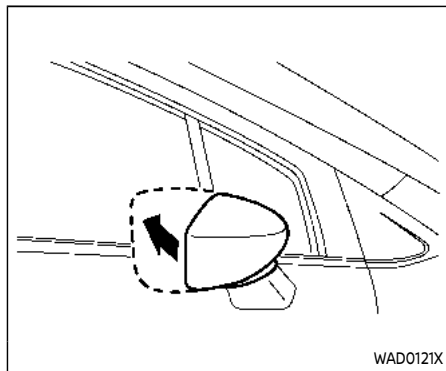

Example

Foldable outside mirrors

Fold the outside mirror by pushing it toward the rear of the vehicle.

Reverse tilt-down feature (if so equipped)

When backing up the vehicle, the right or left outside mirror will turn downward automatically to provide better rear visibility.

1. Place the ignition switch in the ON position.
2. Move the shift lever to the R (Reverse) position.

3. Choose the right or left outside mirror by operating the outside mirror control switch.
4. The selected outside mirror surface moves downward.

When one of the following conditions has occurred, the outside mirror surface will return to its original position.

- The shift lever is moved out of the R (Reverse) position.
- The vehicle speed exceeds 5 MPH (8 km/h).
- The selected outside mirror is deselected using the outside mirror control switch.
- The ignition switch is placed in the OFF position.
- The engine is stopped.

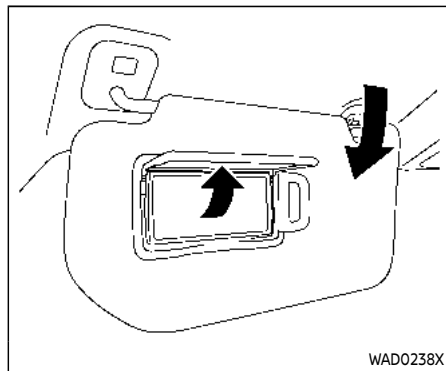

VANITY MIRROR

To use the vanity mirror, pull down the sun visor and pull up the cover.

MEMORY SEAT (if so equipped)

The memory seat system has the following features:

- Memory storage function
- Entry/exit function

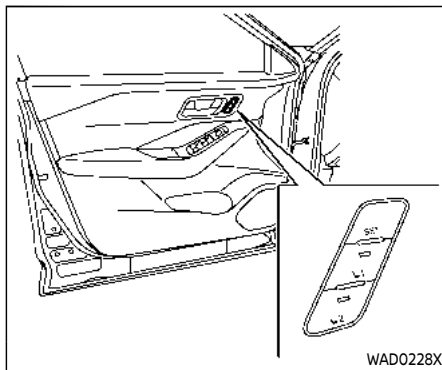

MEMORY STORAGE FUNCTION

Two positions for the driver's seat and outside mirrors can be stored in the memory switch. Follow these procedures to use the memory system.

1. Adjust the driver's seat and outside mirrors to the desired positions by manually operating each adjusting switch. For additional information, refer to "Seats" (P.1-3) and "Outside mirrors" (P.3-35).
2. Push the SET switch and, within 5 seconds, push the memory switch (1 or 2).

3. The indicator light for the pushed memory switch will come on and stay on for approximately 5 seconds.
4. The chime will sound if the memory has been stored.

NOTE:

If a new memory position is stored in the same memory switch, the previous memory position will be overwritten by the new stored position.

Confirming memory storage

Push the SET switch. If a memory position has not been stored in the switch (1 or 2) the indicator light for the respective switch will come ON for approximately 0.5 seconds. If a memory position has been stored in the switch (1 or 2) then the indicator light for the respective switch will stay ON for approximately 5 seconds.

Recalling switch memory positions

To recall the manually stored positions, push the memory switch (1 or 2). The driver's seat and the outside mirrors will move to the positions stored in the memory switch.

Linking log-in function to a stored memory position (models with navigation system)

The log-in function can be linked to a stored memory position with the following procedure.

1. Place the ignition switch in the ON position while carrying the Intelligent Key that was registered to the vehicle with a log-in function.

NOTE:



Make sure the Intelligent Key is far apart. Otherwise, the vehicle may detect the wrong Intelligent Key.

2. Adjust the position of the driver's seat and outside mirrors. (See "Seats" (P.1-3) and "Outside mirrors" (P.3-35).)
3. Place the ignition switch in the OFF position.

The next time you log in (selecting the user on the display) after placing the ignition switch in the ON position while carrying the Intelligent Key, the system will automatically adjust to the memorized driving position. (See the separate NissanConnect® Owner's Manual.)

Linking an Intelligent Key to a stored memory position (models without navigation system)

Each Intelligent Key can be linked to a stored memory position (memory switch 1 or 2) with the following procedure.

1. Follow steps 1-3 in the "Memory storage function" (P.3-37) for storing the memory position.
2. The indicator light for the pushed memory switch will come on. While the indicator light is on for 5 seconds, press the  button and the  button on the Intelligent Key in succession. The indicator light of the linked memory switch will blink. After the indicator light goes off, the Intelligent Key is linked to that memory setting.

Once it is linked, when ignition switch is placed in the OFF position, pressing the  button on the Intelligent Key will move the driver's seat and outside mirrors to the linked memory switch position.

NOTE:

If a new memory position is stored in the linked memory switch, then the Intelligent Key will link the new position and overwrites the previous position.

ENTRY/EXIT FUNCTION

This system is designed so that the driver's seat will automatically move when the shift position is in the P (Park) position. This allows the driver to get into and out of the driver's seat more easily.

The driver's seat will slide backward:

- When the driver's door is opened with the ignition switch placed in the OFF position.
- When the ignition switch is changed from ON to OFF with the driver's door open.

The driver's seat will return to the previous position:

- When the ignition switch is placed in the ON position while the shift position is in the P (Park) position.

The entry/exit function can be canceled through "Vehicle Settings" in the vehicle information display by performing the following:

- Switch the "Exit Seat Slide" from ON to OFF. For additional information, refer to "Vehicle Settings" (P.2-28).

SYSTEM OPERATION

The memory seat system will not work or will stop operating under the following conditions:

- When the vehicle is moving. (The driver's seat returning function can be operated if the vehicle speed is below 2 MPH (3 km/h).)
- When any of the memory switches are pushed while the memory seat system is operating.
- When the switch for the driver's seat is pushed while the memory seat system is operating.
- When the seat has already been moved to the memorized position.
- When no seat position is stored in the memory switch.
- When the shift lever is moved from P (Park) to any other position.

MEMO

4 Monitor, heater, air conditioner, audio and phone systems

NissanConnect® Owner's Manual	4-2	Moving Object Detection (MOD) (if so equipped)	4-22
RearView Monitor (if so equipped)	4-3	MOD system operation	4-23
RearView Monitor system operation	4-4	Turning MOD on and off	4-24
How to read the displayed lines	4-4	MOD system limitations	4-24
Difference between predictive and actual distances	4-4	System maintenance	4-25
How to park with predictive course lines	4-6	Ventilators	4-26
Adjusting the screen	4-8	Center ventilators	4-26
How to turn on and off predictive course lines	4-8	Side ventilators	4-26
RearView Monitor system limitations	4-8	Rear ventilators	4-27
System maintenance	4-9	Heater and air conditioner	4-27
Intelligent Around View® Monitor (if so equipped)	4-10	Manual air conditioner and heater	4-28
Intelligent Around View® Monitor system operation	4-11	Automatic air conditioner (models without rear control)	4-32
Difference between predictive and actual distances	4-15	Automatic air conditioner (models with rear control)	4-35
How to park with predictive course lines	4-17	Operating tips (for automatic air conditioner)	4-37
How to switch the display	4-18	Servicing air conditioner	4-38
Adjusting the screen	4-19	Radio Antenna	4-39
Intelligent Around View® Monitor system limitations	4-19	Car phone or CB radio	4-39
System maintenance	4-21		

NISSANCONNECT® OWNER'S MANUAL



- Navigation system
- Voice recognition
- Information and settings viewable on NissanConnect®

For models with NissanConnect® System, refer to the digital NissanConnect® Owner's Manual using the QR code on this page (US only), or your printed NissanConnect® Owner's Manual (if so equipped). This manual includes the following information.

Available functions may vary depending on the models and specifications.

- Audio
- Hands-Free Phone
- Apple CarPlay®
- Android Auto™
- NissanConnect® Services powered by SiriusXM®

REARVIEW MONITOR (if so equipped)

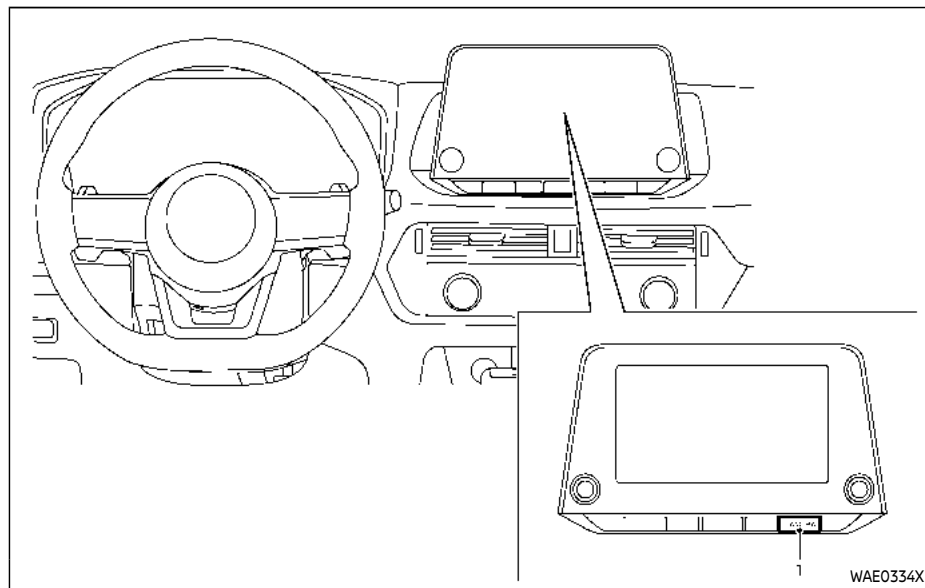

1. CAMERA button

WARNING

- Failure to follow the warnings and instructions for proper use of the RearView Monitor could

result in serious injury or death.

- RearView Monitor is a convenience feature and is not a substitute for proper backing. Always turn and look out the windows, and check mirrors to be sure that it is safe to move before operat-

ing the vehicle. Always back up slowly.

- The system is designed as an aid to the driver in showing large stationary objects directly behind the vehicle, to help avoid damaging the vehicle.
- The distance guide line and the vehicle width line should be used as a reference only when the vehicle is on a level paved surface. The distance viewed on the monitor is for reference only and may be different than the actual distance between the vehicle and displayed objects.



CAUTION

Do not scratch the camera lens when cleaning dirt or snow from the front of the camera.

The RearView Monitor system automatically shows a rear view of the vehicle when the shift lever is placed in the R (Reverse) position.

The radio can still be heard while the RearView Monitor is active.

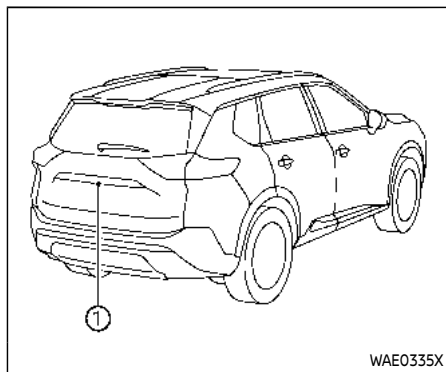

To display the rear view, the RearView Monitor system uses a camera ① located just above the vehicle's license plate.

REARVIEW MONITOR SYSTEM OPERATION

When the ignition switch is placed in the ON position, move the shift lever to the R (Reverse) position to operate the RearView Monitor.

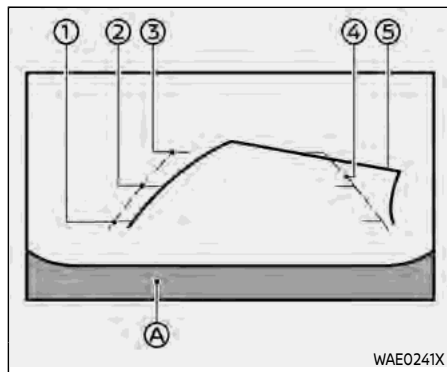

HOW TO READ THE DISPLAYED LINES

Guiding lines which indicate the vehicle width and distances to objects with reference to the bumper line ④ are displayed on the monitor.

Distance guide lines:

Indicate distances from the vehicle body.

- Red line ①: approximately 1.5 ft (0.5 m)
- Yellow line ②: approximately 3 ft (1 m)
- Green line ③: approximately 7 ft (2 m)

Vehicle width guide lines ④:

Indicate the vehicle width when backing up.

Predictive course lines ⑤:

Indicate the predictive course when backing up. The predictive course lines will be displayed on the monitor when the shift lever is in the R (Reverse) position and if the steering wheel is turned. The predictive course lines will move depending on how much the steering wheel is turned and will not be displayed while the steering wheel is in the straight ahead position.

The vehicle width guide lines and the width of the predictive course lines are wider than the actual width and course.

DIFFERENCE BETWEEN PREDICTIVE AND ACTUAL DISTANCES

The displayed guide lines and their locations on the ground are for approximate reference only. Objects on uphill or downhill surfaces or projecting objects will be actually located at distances different from those displayed in the monitor relative to the guide lines (refer to illustrations). When in doubt, turn around and view the objects as you are backing up, or park and exit the vehicle to view the positioning of objects behind the vehicle.

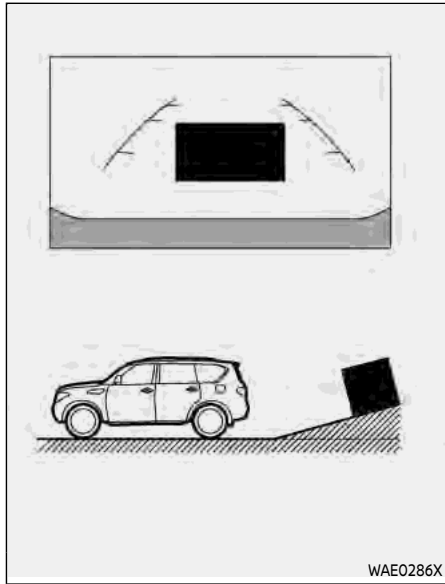

Backing up on a steep uphill

When backing up the vehicle up a hill, the distance guide lines and the vehicle width guide lines are shown closer than the actual distance. Note that any object on the hill is farther than it appears on the monitor.

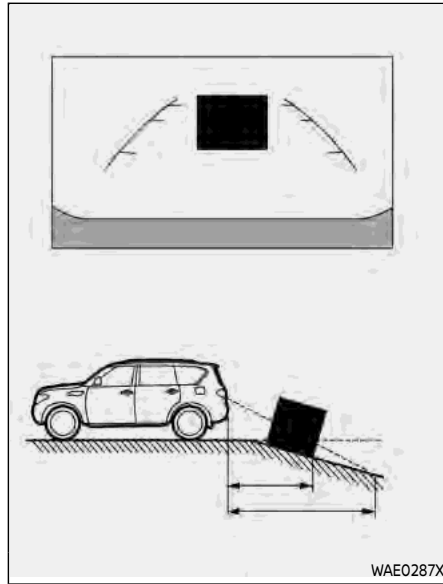

Backing up on a steep downhill

When backing up the vehicle down a hill, the distance guide lines and the vehicle width guide lines are shown farther than the actual distance. Note that any object on the hill is closer than it appears on the monitor.

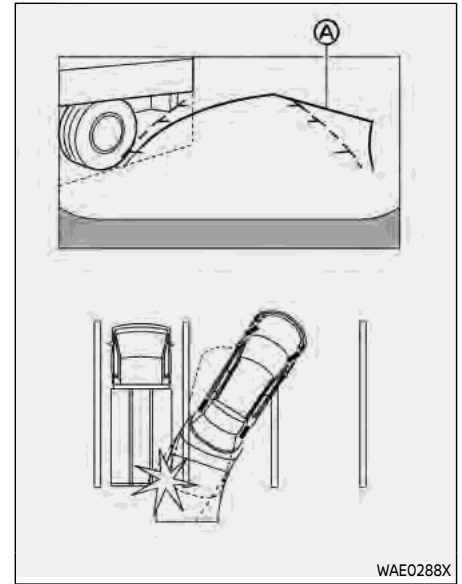

Backing up near a projecting object

The predictive course lines [Ⓐ] do not touch the object in the display. However, the vehicle may hit the object if it projects over the actual backing up course.

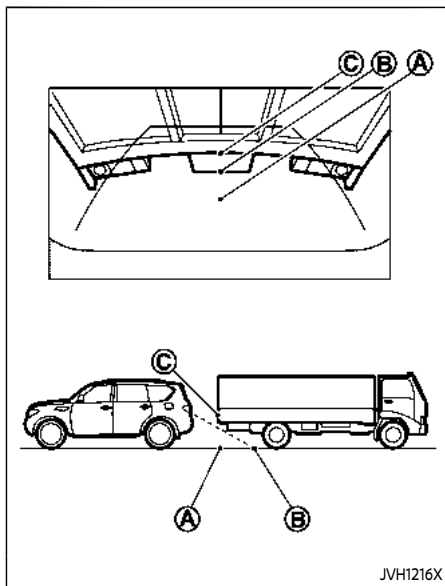

position ③ if the object projects over the actual backing up course.

HOW TO PARK WITH PREDICTIVE COURSE LINES

WARNING

- If the tires are replaced with different sized tires, the predictive course lines may be displayed incorrectly.
- On a snow-covered or slippery road, there may be a difference between the predictive course line and the actual course line.
- If the battery is disconnected or becomes discharged, the predictive course lines may be displayed incorrectly. If this occurs, please perform the following procedures:
 - Turn the steering wheel from lock to lock while the engine is running.
 - Drive the vehicle on a straight road for more than 5 minutes.
- When the steering wheel is turned with the ignition switch in the ON position, the predictive course lines may be displayed

incorrectly.

Backing up behind a projecting object

The position ③ is shown farther than the position ② in the display. However, the position ③ is actually at the same distance as the position ②. The vehicle may hit the object when backing up to the

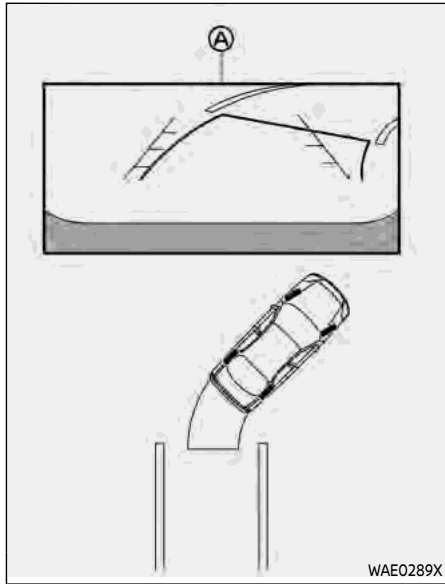

1. Visually check that the parking space is safe before parking your vehicle.
2. The rear view of the vehicle is displayed on the screen **A** when the shift lever is moved to the R (Reverse) position.

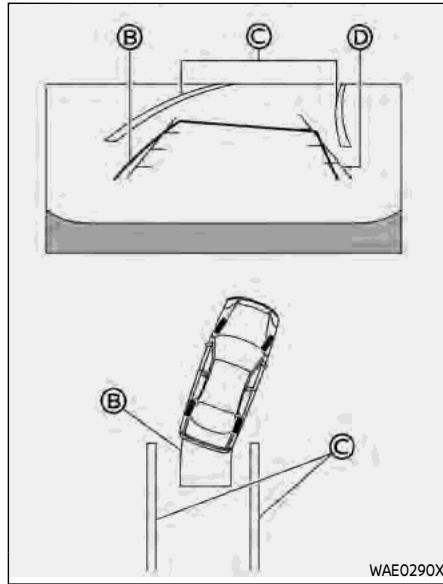

3. Slowly back up the vehicle adjusting the steering wheel so that the predictive course lines **B** enter the parking space **C**.
4. Maneuver the steering wheel to make the vehicle width guide lines **D** parallel to the parking space **C** while referring to the predictive course lines.

5. When the vehicle is parked in the space completely, place the shift position to the P (Park) position and apply the parking brake.

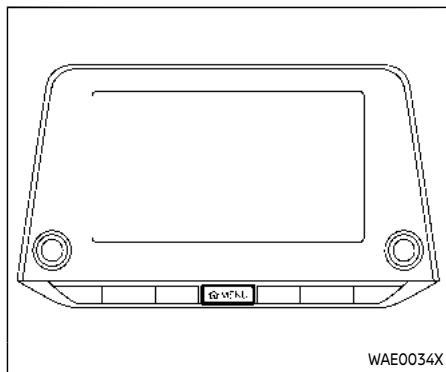

ADJUSTING THE SCREEN

1. Push the MENU button.
2. Touch the "Settings" key and then touch the "Camera" key.
3. Touch the "Display Settings" key.
4. Touch the "Brightness", "Contrast", "Tint", "Color", or "Black Level" key.
5. Adjust the item by touching the "+" or "-" key on the touch screen display.

NOTE:

Do not adjust any of the display settings of the RearView Monitor while the vehicle is moving. Make sure the parking brake is firmly applied.

HOW TO TURN ON AND OFF PREDICTIVE COURSE LINES

To turn the predictive course lines on and off when the shift lever is in the P (Park) position, perform the following operation.

1. Push the MENU button.
2. Touch the "Settings" key and then touch the "Camera" key.
3. Touch the "Predictive Course Lines" key to turn the feature ON or OFF.

Pushing the CAMERA button while the shift lever is in the R (Reverse) position can turn on and off the predictive course lines.

REARVIEW MONITOR SYSTEM LIMITATIONS

WARNING

Listed below are the system limitations for RearView Monitor. Failure to operate the vehicle in accordance with these system limitations could result in serious injury or death.

- The system cannot completely eliminate blind spots and may not show every object.

- **Underneath the bumper and the corner areas of the bumper cannot be viewed on the RearView Monitor because of its monitoring range limitation. The system will not show small objects below the bumper, and may not show objects close to the bumper or on the ground.**
- **Objects viewed in the RearView Monitor differ from actual distance because a wide-angle lens is used.**
- **Objects in the RearView Monitor will appear visually opposite compared to when viewed in the rearview and outside mirrors.**
- **Use the displayed lines as a reference. The lines are highly affected by the number of occupants, fuel level, vehicle position, road conditions and road grade.**
- **Make sure that the liftgate is securely closed when backing up.**
- **Do not put anything on the rearview camera. The rearview camera is installed above the license plate.**

- When washing the vehicle with high-pressure water, be sure not to spray it around the camera. Otherwise, water may enter the camera unit causing water condensation on the lens, a malfunction, fire or an electric shock.
- Do not strike the camera. It is a precision instrument. Otherwise, it may malfunction or cause damage resulting in a fire or an electric shock.

The following are operating limitations and do not represent a system malfunction:

- When the temperature is extremely high or low, the screen may not clearly display objects.
- When strong light directly shines on the camera, objects may not be displayed clearly.
- Vertical lines may be seen in objects on the screen. This is due to strong reflected light from the bumper.
- The screen may flicker under fluorescent light.
- The colors of objects on the RearView Monitor may differ somewhat from the actual color of objects.

- Objects on the monitor may not be clear in a dark environment.
- There may be a delay when switching between views.
- If dirt, rain or snow accumulates on the camera, the RearView Monitor may not display objects clearly. Clean the camera.
- Do not use wax on the camera lens. Wipe off any wax with a clean cloth dampened with a diluted mild cleaning agent, then wipe with a dry cloth.

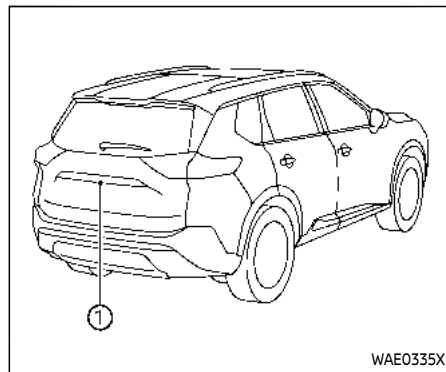

SYSTEM MAINTENANCE



CAUTION

- Do not use alcohol, benzine or thinner to clean the camera. This will cause discoloration.
- Do not damage the camera as the monitor screen may be adversely affected.

If dirt, rain or snow accumulates on the camera ①, RearView Monitor may not display objects clearly. Clean the camera by wiping it with a cloth dampened with a

INTELLIGENT AROUND VIEW® MONITOR (if so equipped)

diluted mild cleaning agent and then wiping it with a dry cloth.

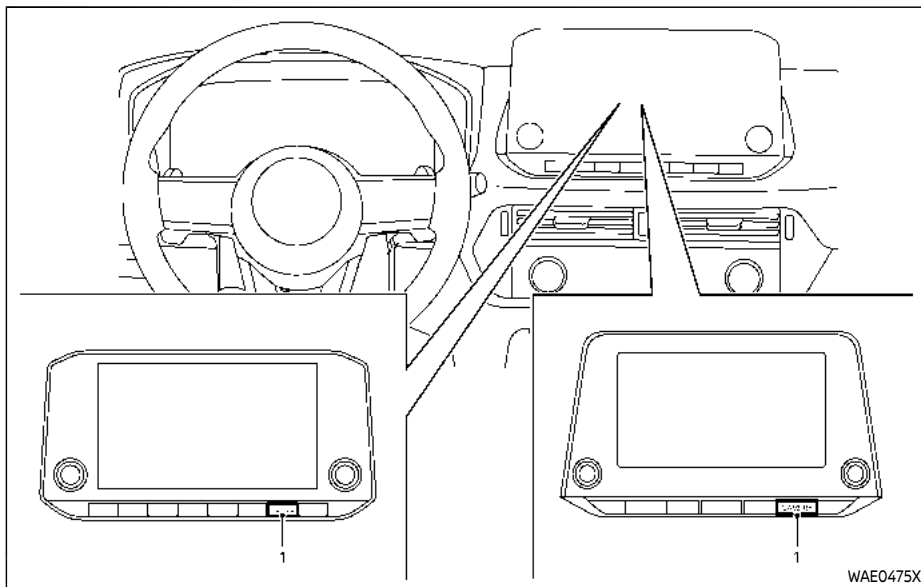

1. CAMERA button

WARNING

- Failure to follow the warnings and instructions for the proper use of the Intelligent Around

View® Monitor system could result in serious injury or death.

- The Intelligent Around View® Monitor is a convenience feature and is not a substitute for proper vehicle operation because it has areas where objects cannot be

viewed. The four corners of the vehicle in particular, are areas where objects do not always appear in the bird's-eye, front, or rear views. Always check your surroundings to be sure that it is safe to move before operating the vehicle. Always operate the vehicle slowly.

- The driver is always responsible for safety during parking and other maneuvers.



CAUTION

Do not scratch the lens when cleaning dirt or snow from the front of the camera.

The Intelligent Around View® Monitor system is designed as an aid to the driver in situations such as slot parking or parallel parking.

The monitor displays various views of the position of the vehicle in a split screen format. Not all views are available at all times.

Available views:

- Front view
A view of the front of the vehicle
- Rear view
A view of the rear of the vehicle
- Bird's-eye view
The surrounding view of the vehicle from above
- Front-side view
The view around and ahead of the front passenger's side wheel
- Front-wide view
A wider area view of the front view
- Rear-wide view
A wider area view of the rear view

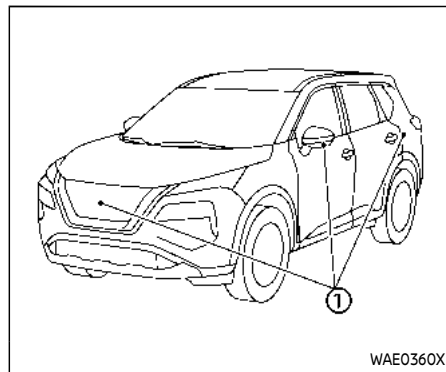

WAE0360X

To display the multiple views, the Intelligent Around View® Monitor system uses cameras ① located on the front grille, on the vehicle's outside mirrors and one just above the vehicle's rear license plate.

INTELLIGENT AROUND VIEW® MONITOR SYSTEM OPERATION

When the ignition switch is placed in the ON position, push the CAMERA button on the instrument panel or move the shift lever to the R (Reverse) position to operate the Intelligent Around View® Monitor.

The screen displayed on the Intelligent Around View® Monitor will automatically return to the previous screen 3 minutes

after the CAMERA button has been pushed with the shift lever in a position other than the R (Reverse) position.

Available views



WARNING

- The distance guide lines and the vehicle width guide lines should be used as a reference only when the vehicle is on a paved, level surface. The apparent distance viewed on the monitor may be different than the actual distance between the vehicle and displayed objects.
- Use the displayed lines and the bird's-eye view as a reference. The lines and the bird's-eye view are greatly affected by the number of occupants, fuel level, vehicle position, road condition and road grade.
- If the tires are replaced with different sized tires, the predictive course lines and the bird's-eye view may be displayed incorrectly.
- When driving the vehicle up a hill, objects viewed in the monitor are

farther than they appear. When driving the vehicle down a hill, objects viewed in the monitor are closer than they appear.

- Objects in the rear view will appear visually opposite compared to when viewed in the rearview and outside mirrors.
- Use the mirrors or actually look to properly judge distances to other objects.
- The distance between objects viewed in the rear view differs from actual distance because a wide-angle lens is used.
- On a snow-covered or slippery road, there may be a difference between the predictive course line and the actual course line.
- The vehicle width and predictive course lines are wider than the actual width and course.

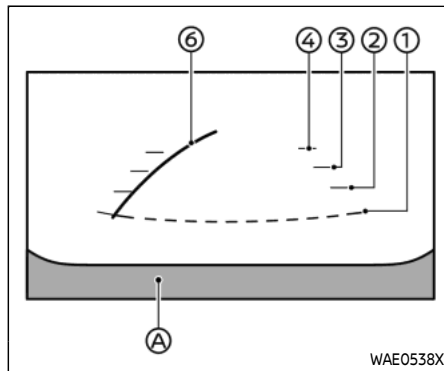

Front view

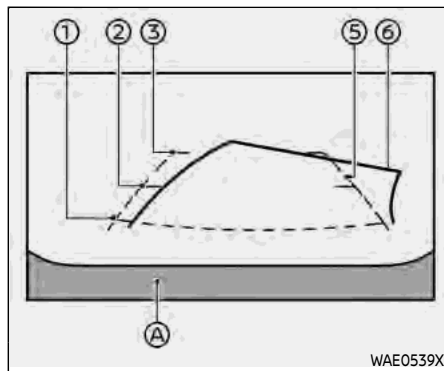

Rear view (example)

Front and rear view:

Guiding lines that indicate the approximate vehicle width and distances to objects with reference to the vehicle body line ④, are displayed on the monitor.

Distance guide lines:

Indicate distances from the vehicle body.

- Red line ①: approximately 1.5 ft (0.5 m)
- Yellow line ②: approximately 3 ft (1 m)
- Green line ③: approximately 7 ft (2 m)
- Green line ④ (if so equipped): approximately 10 ft (3 m)

Vehicle width guide lines ⑤:

Indicate the vehicle width.

Predictive course lines ⑥:

Indicate the predictive course when operating the vehicle. The predictive course lines will move depending on how much the steering wheel is turned. The predictive course lines in the rear view will not be displayed while the steering wheel is in the straight ahead position.

The front view will not be displayed when the vehicle speed is above 6 MPH (10 km/h).

NOTE:

- **When the monitor displays the front view and the steering wheel turns about 90 degrees or less from the straight ahead position, both the**

right and left predictive course lines ⑥ are displayed. When the steering wheel turns about 90 degrees or more, the predictive course line is displayed only on the opposite side of the turn.

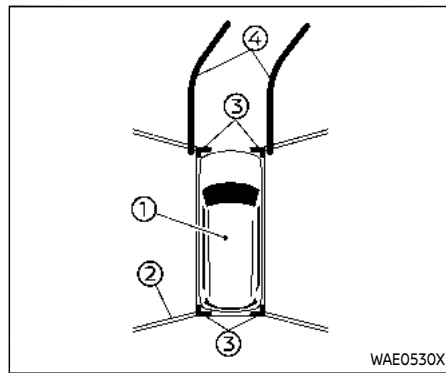

Bird's-eye view:

The bird's-eye view shows the overhead view of the vehicle which helps confirm the vehicle position and the predictive course to a parking space.

The vehicle icon ① shows the position of the vehicle. Note that the distance between objects viewed in the bird's-eye view differs from the actual distance.

The areas between the camera views ② (if so equipped) are indicated in black.

After the ignition switch is placed in the ON position, the non-viewable area ② (if so equipped) is highlighted in yellow for a few seconds after the bird's-eye view is displayed.

The amber markers ③ are displayed when the sonar is turned off or the sonar is not available at the corner.

The predictive course lines ④ indicate the predicted course when operating the vehicle.

WARNING

- Objects in the bird's-eye view will appear farther than the actual distance.
- Tall objects, such as a curb or vehicle, may be misaligned or not displayed at the seam of the views.
- Objects that are above the camera cannot be displayed.
- The view for the bird's-eye view may be misaligned when the camera position alters.
- A line on the ground may be misaligned and is not seen as being straight at the seam of the views. The misalignment will increase as the line proceeds away from the vehicle.

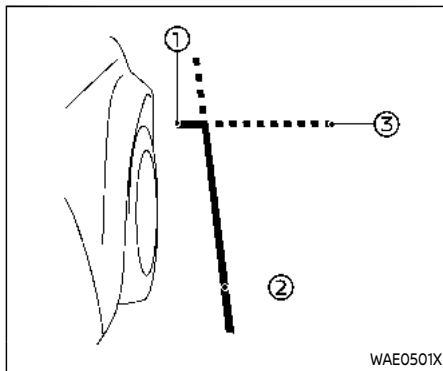

Front-side view:

Guiding lines:

Guiding lines that indicate the approximate width and the front end of the vehicle are displayed on the monitor.

The front-of-vehicle line ① shows the front part of the vehicle.

The side-of-vehicle line ② shows the vehicle width including the outside mirrors.

The extensions ③ of both the front ① and side ② lines are shown with a green dotted line.

CAUTION

The turn signal light may look like the side-of-vehicle line. This is not a malfunction.

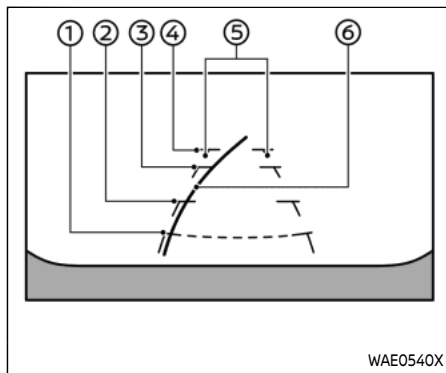

Front-wide view

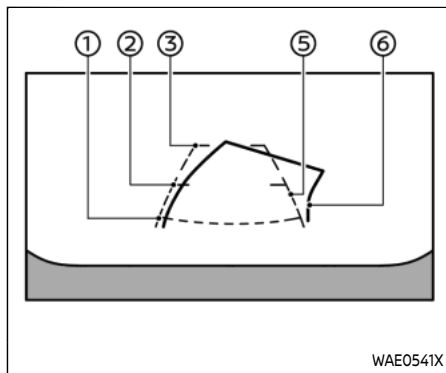

Rear-wide view

Front-wide/rear-wide view:

While the front view/rear view shows a normal view on the split screens, the front-wide view/rear-wide view shows a wider area on the entire screen and allows checking of the blind corners on the right and left sides.

Distance guide lines ① - ④ :

Indicate distances from the vehicle body.

- Red line ①: approx. 1.5 ft (0.5 m)
- Yellow line ②: approx. 3 ft (1 m)
- Green line ③: approx. 7 ft (2 m)
- Green line ④ (front-wide view only): approx. 10 ft (3 m)

Vehicle width guide lines ⑤ :

Indicate the approximate vehicle width.

Predictive course lines ⑥ :

Indicate the predictive course when operating the vehicle. The predictive course lines will move depending on how much the steering wheel is turned. The predictive course lines in the rear-wide view will not be displayed while the steering wheel is in the straight ahead position.

The front-wide view will not be displayed when the vehicle speed is above 6 MPH (10 km/h).

NOTE:

- When the monitor displays the front-wide view and the steering wheel turns about 90 degrees or less from the straight ahead position, both the right and left predictive course lines ⑥ are displayed. When the steering wheel turns about 90 degrees or more, the predictive course line is displayed only on the opposite side of the turn.

DIFFERENCE BETWEEN PREDICTIVE AND ACTUAL DISTANCES

The displayed guide lines and their locations on the ground are for approximate reference only. Objects on uphill or downhill surfaces or projecting objects will be actually located at distances different from those displayed in the monitor relative to the guide lines (refer to illustrations). When in doubt, turn around and view the objects as you are backing up, or park and exit the vehicle to view the positioning of objects behind the vehicle.

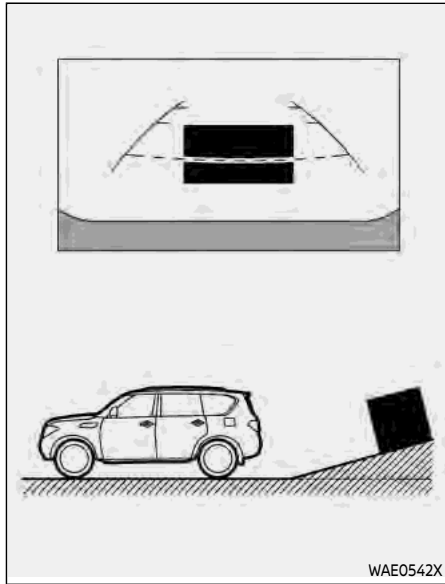

Backing up on a steep uphill

When backing up the vehicle up a hill, the distance guide lines and the vehicle width guide lines are shown closer than the actual distance. Note that any object on the hill is farther than it appears on the monitor.

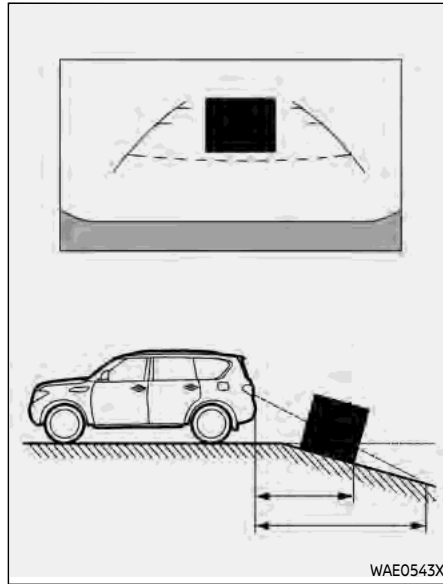

Backing up on a steep downhill

When backing up the vehicle down a hill, the distance guide lines and the vehicle width guide lines are shown farther than the actual distance. Note that any object on the hill is closer than it appears on the monitor.

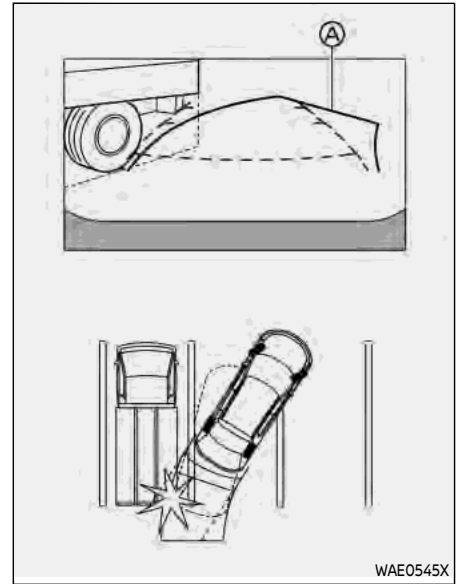

Backing up near a projecting object

The predictive course lines Ⓐ do not touch the object in the display. However, the vehicle may hit the object if it projects over the actual backing up course.

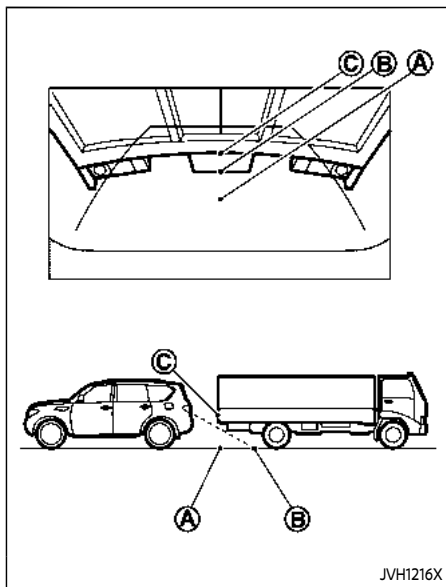

Backing up behind a projecting object

The position © is shown farther than the position Ⓑ in the display. However, the position © is actually at the same distance as the position Ⓐ. The vehicle may hit the object when backing up to the

position Ⓐ if the object projects over the actual moving course.

HOW TO PARK WITH PREDICTIVE COURSE LINES

WARNING

- If the tires are replaced with different sized tires, the predictive course lines may be displayed incorrectly.
- On a snow-covered or slippery road, there may be a difference between the predictive course line and the actual course line.
- If the battery is disconnected or becomes discharged, the predictive course lines may be displayed incorrectly. If this occurs, please perform the following procedures:
 - Turn the steering wheel from lock to lock while the engine is running.
 - Drive the vehicle on a straight road for more than 5 minutes.
- When the steering wheel is turned with the ignition switch in the ON position, the predictive course lines may be displayed

incorrectly.

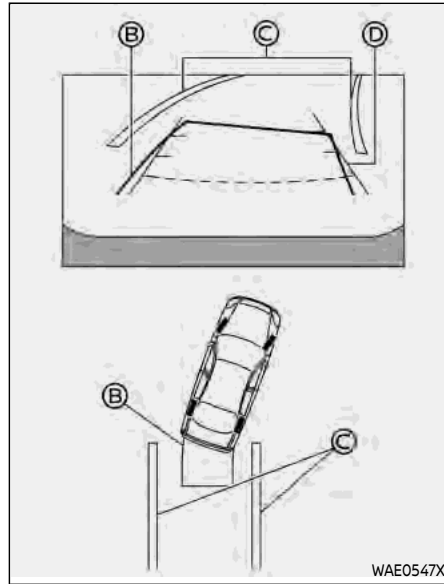
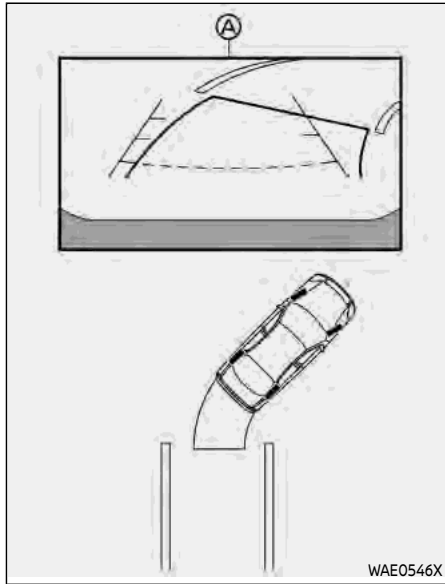

1. Visually check that the parking space is safe before parking your vehicle.
2. The rear view of the vehicle is displayed on the screen **A** when the shift lever is moved to the R (Reverse) position.

3. Slowly back up the vehicle adjusting the steering wheel so that the predictive course lines **B** enter the parking space **C**.
4. Maneuver the steering wheel to make the vehicle width guide lines **D** parallel to the parking space **C** while referring to the predictive course lines.

5. When the vehicle is parked in the space completely, place the shift position in the P (Park) position and apply the parking brake.

HOW TO SWITCH THE DISPLAY

With the ignition switch placed in the ON position, push the CAMERA button or move the shift lever to the R (Reverse) position to operate the Intelligent Around View® Monitor.

The Intelligent Around View® Monitor displays different split screen views depending on the position of the shift lever. Push the CAMERA button to switch between the available views.

If the shift lever is in the R (Reverse) position, the available views are:

- Rear view/bird's-eye view split screen
- Rear view/front-side view split screen
- Rear-wide view

If the shift lever is out of the R (Reverse) position, the available views are:

- Front view/bird's-eye view split screen
- Front view/front-side view split screen
- Front-wide view

The display will switch from the Intelligent Around View® Monitor screen when:

- The shift lever is in the D (Drive) position and the vehicle speed increases above approximately 6 MPH

(10 km/h).

- A different screen is selected.

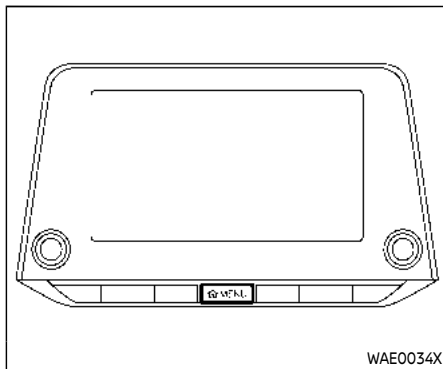

Type A

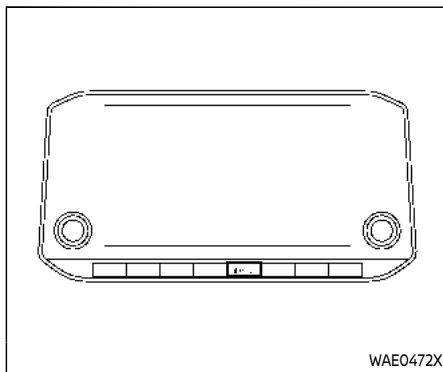

Type B

ADJUSTING THE SCREEN

1. Push the MENU button.
2. Touch the "Settings" key and then touch the "Camera" key.
3. Touch the "Display Settings" key.
4. Touch the "Brightness", "Contrast", "Tint", "Color", or "Black Level" key.
5. Adjust the item by touching the "+" or "-" key on the touch screen display.

NOTE:

Do not adjust the display settings of the Intelligent Around View® Monitor while the vehicle is moving. Make sure the parking brake is firmly applied.

INTELLIGENT AROUND VIEW® MONITOR SYSTEM LIMITATIONS



WARNING

Listed below are the system limitations for Intelligent Around View® Monitor. Failure to operate the vehicle in accordance with these system limitations could result in serious injury or death.

- Do not use the Intelligent Around View® Monitor with the outside mirrors in the stored position, and make sure that the liftgate

is securely closed when operating the vehicle using the Intelligent Around View® Monitor.

- The apparent distance between objects viewed on the Intelligent Around View® Monitor differs from the actual distance.
- The cameras are installed on the front grille, the outside mirrors and above the rear license plate. Do not put anything on the cameras.
- When washing the vehicle with high pressure water, be sure not to spray it around the cameras. Otherwise, water may enter the camera unit causing water condensation on the lens, a malfunction, fire or an electric shock.
- Do not strike the cameras. They are precision instruments. Doing so could cause a malfunction or cause damage resulting in a fire or an electric shock.

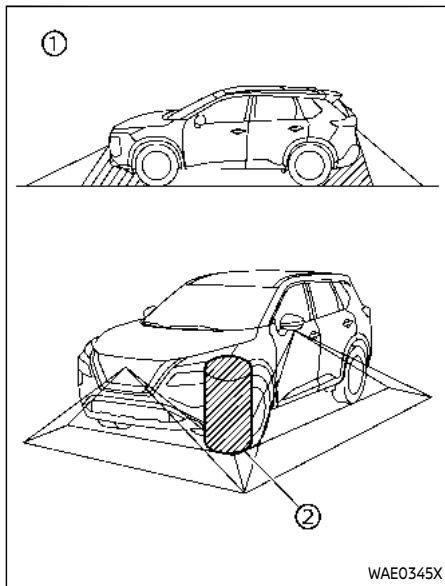

There are some areas where the system will not show objects and the system does not warn of moving objects. When in the front or the rear view display, an object below the bumper or on the ground may not be viewed ①. When in the bird's-eye view, a tall object near the seam ② of the camera viewing areas will

not appear in the monitor.

The following are operating limitations and do not represent a system malfunction:

- There may be a delay when switching between views.
- When the temperature is extremely high or low, the screen may not display objects clearly.
- When strong light directly shines on the camera, objects may not be displayed clearly.
- The screen may flicker under fluorescent light.
- The colors of objects on the Intelligent Around View® Monitor may differ somewhat from the actual color of objects.
- Objects on the Intelligent Around View® Monitor may not be clear and the color of the object may differ in a dark environment.
- There may be differences in sharpness between each camera view of the bird's-eye view.
- Do not use wax on the camera lens. Wipe off any wax with a clean cloth that has been dampened with a diluted mild cleaning agent, then wipe with a dry cloth.

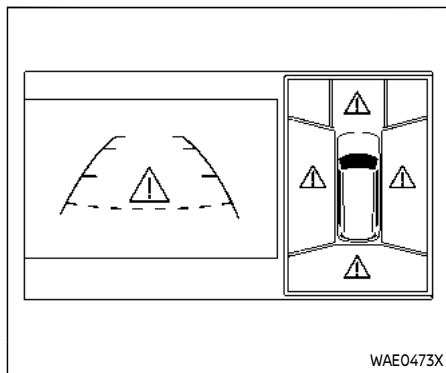

System temporarily unavailable

When the "⚠" icon is displayed on the screen, there will be abnormal conditions in the Intelligent Around View® Monitor. This will not hinder normal driving operation but the system should be inspected. It is recommended you visit a NISSAN dealer.

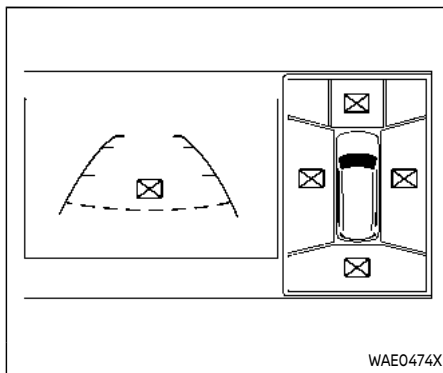

When the "⊠" icon is displayed on the screen, the camera image may be receiving temporary electronic disturbances from surrounding devices. This will not hinder normal driving operation but the system should be inspected. It is recommended you visit a NISSAN dealer.

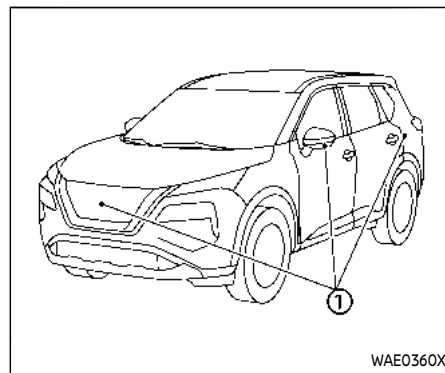

SYSTEM MAINTENANCE



- Do not use alcohol, benzine or thinner to clean the camera. This will cause discoloration.
- Do not damage the camera as the monitor screen may be adversely affected.

If dirt, rain or snow accumulates on any of the cameras ①, the Intelligent Around View® Monitor may not display objects clearly. Clean the camera by wiping with a

MOVING OBJECT DETECTION (MOD) (if so equipped)

cloth dampened with a diluted mild cleaning agent and then wiping with a dry cloth.

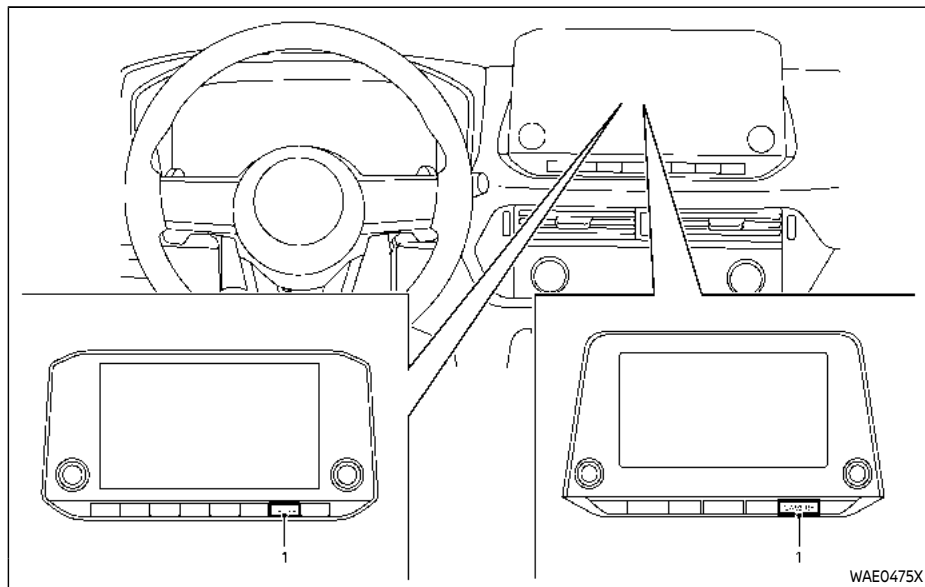

1. CAMERA button

WARNING

- Failure to follow the warnings and instructions for proper use of the Moving Object Detection

system could result in serious injury or death.

- The MOD system is not a substitute for proper vehicle operation and is not designed to prevent contact with objects surrounding the vehicle. When maneuvering,

always use the outside mirror and rearview mirror and turn and check the surroundings to ensure it is safe to maneuver.

- **The system is deactivated at speeds above 5 MPH (8 km/h). It is reactivated at lower speeds.**
- **The MOD system is not designed to detect the surrounding stationary objects.**

The MOD system can inform the driver of moving objects near the vehicle when driving out of garages, maneuvering in parking lots and in other such instances.

The MOD system detects moving objects by using image processing technology on the image shown in the display.

MOD SYSTEM OPERATION

The MOD system will turn on automatically under the following conditions:

- When the shift lever is in the R (Reverse) position.
- When the CAMERA button is pushed to activate the Intelligent Around View® Monitor system on the display.
- When vehicle speed decreases below approximately 5 MPH (8 km/h).

The MOD system operates in the following conditions when the camera view is

displayed:

- When the shift lever is in the P (Park) or N (Neutral) position and the vehicle is stopped, the MOD system detects the moving objects in the bird's-eye view. The MOD system will not operate if either door is opened. If outside mirrors are folded, MOD may not operate properly.
- When the shift lever is in the D (Drive) position, and the vehicle speed is below approximately 5 MPH (8 km/h), the MOD system detects moving objects in the front view or front-wide view.
- When the shift lever is in the R (Reverse) position and the vehicle speed is below approximately 5 MPH (8 km/h), the MOD system detects moving objects in the rear view or rear-wide view. The MOD system will not operate if the liftgate is open.

The MOD system does not detect moving objects in the front-side view. The MOD icon is not displayed on the screen when in this view.

When the MOD system detects a moving object near the vehicle, the yellow frame will be displayed on the view where the object is detected and a chime will sound once. While the MOD system continues to detect moving objects, the yellow frame

continues to be displayed.

NOTE:

While the RCTA chime (if so equipped) is beeping, the MOD system does not chime.

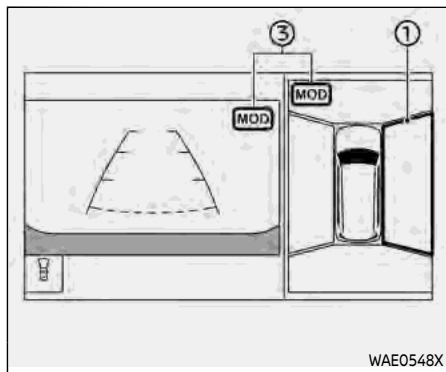

Front and bird's-eye views

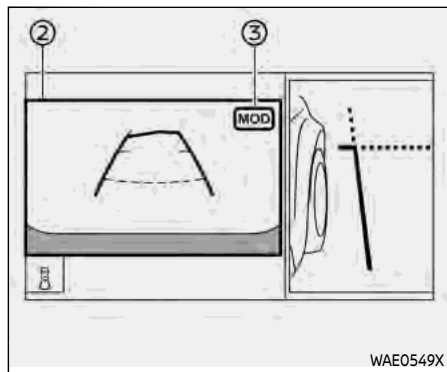

Rear and front-side views

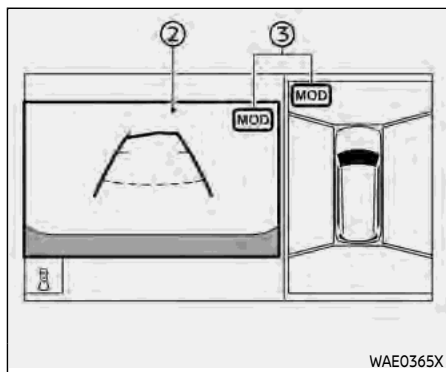

Rear and bird's-eye views

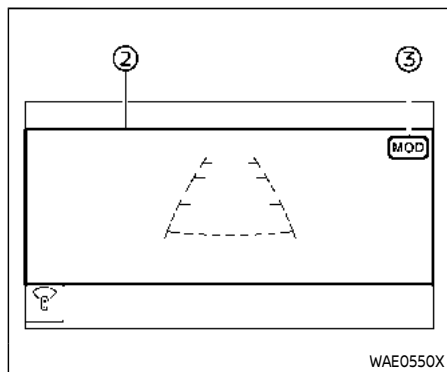

Front-wide view / rear-wide view

In the bird's-eye view, the yellow frame ① is displayed on each camera image (front, rear, right, left) depending on where moving objects are detected.

The yellow frame ② is displayed on the front view, rear view, front-wide view and rear-wide view.

A green MOD icon ③ is displayed in the view where the MOD system is operative. A gray MOD icon ③ is displayed in the view where the MOD system is not operative.

If the MOD system is turned off, the MOD icon ③ is not displayed.

TURNING MOD ON AND OFF

The MOD system can be turned on and off using the vehicle information display. (See "Driver Assistance" (P.2-24).)

MOD SYSTEM LIMITATIONS

WARNING

Listed below are the system limitations for MOD. Failure to operate the vehicle in accordance with these system limitations could result in serious injury or death.

- Do not use the MOD system when towing a trailer. The system may not function properly.

- Excessive noise (for example, audio system volume or open vehicle window) will interfere with the chime sound, and it may not be heard.
- The MOD system performance will be limited according to environmental conditions and surrounding objects such as:
 - When there is low contrast between background and the moving objects.
 - When there is blinking source of light.
 - When strong light such as another vehicle's headlight or sunlight is present.
 - When camera orientation is not in its usual position, such as when the outside mirror is folded.
 - When there is dirt, water drops or snow on the camera lens.
 - When the position of the moving objects in the display is not changed.
- The MOD system might detect flowing water droplets on the camera lens, white smoke from

the muffler, moving shadows, etc.

- The MOD system may not function properly depending on the speed, direction, distance or shape of the moving objects.
- If your vehicle sustains damage to the parts where the camera is installed, leaving it misaligned or bent, the sensing zone may be altered and the MOD system may not detect objects properly.
- When the temperature is extremely high or low, the screen may not display objects clearly. This is not a malfunction.

NOTE:

The green MOD icon will change to orange if one of the following has occurred.

- When the system is malfunctioning.
- When the component temperature reaches a high level.
- When the rear view camera has detected a blockage.

If the icon light continues to illuminate in orange, have the MOD system checked. It is recommended that you visit a NISSAN dealer for this service.

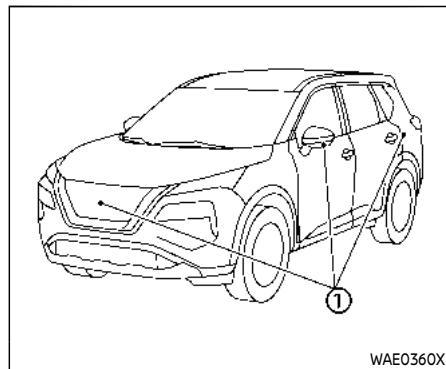

SYSTEM MAINTENANCE



- Do not use alcohol, benzine or thinner to clean the camera. This will cause discoloration.
- Do not damage the camera as the monitor screen may be adversely affected.

If dirt, rain or snow accumulates on any of the cameras ①, the MOD system may not operate properly. Clean the camera by wiping with a cloth dampened with a

VENTILATORS

diluted mild cleaning agent and then wiping with a dry cloth.

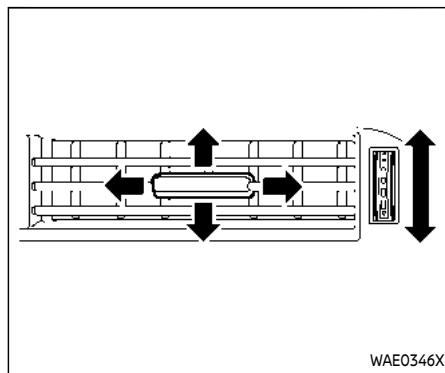

Right side

CENTER VENTILATORS

Open/close the ventilators by moving the control to either direction.

Adjust the air flow direction of the ventilators by moving the center knob (up/down, left/right) until the desired position is achieved.

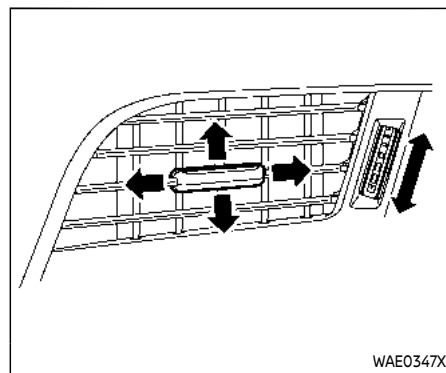

Right side

SIDE VENTILATORS

Open/close the ventilators by moving the control to either direction.

Adjust the air flow direction of the ventilators by moving the center knob (up/down, left/right) until the desired position is achieved.

HEATER AND AIR CONDITIONER

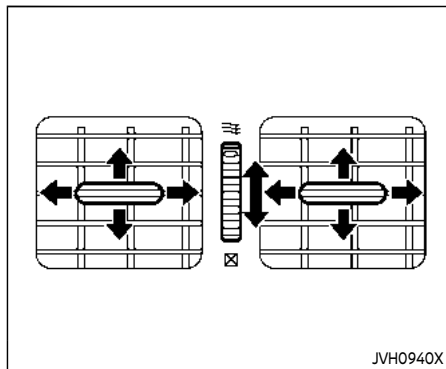

REAR VENTILATORS

Open/close the ventilators by moving the control to either direction.

- ≡ : This symbol indicates that the ventilators are open. Moving the side control to this direction will open the ventilators.
- ☒ : This symbol indicates that the ventilators are closed. Moving the side control to this direction will close the ventilators.

Adjust the air flow direction of the ventilators by moving the center knob (up/down, left/right) until the desired position is achieved.

WARNING

- The heater and air conditioner operate only when the engine is running.
- Never leave children or adults who would normally require the support of others alone in the vehicle. Pets should not be left alone either. They could unknowingly activate switches or controls and inadvertently become involved in a serious accident and injure themselves. On hot, sunny days, temperatures in a closed vehicle could quickly become high enough to cause severe or possibly fatal injuries to people or animals.
- Do not use the recirculation mode for long periods as it may cause the interior air to become stale and the windows to fog up.
- Do not adjust the heating and air conditioning controls while driving so that full attention may be given to vehicle operation.

The heater and air conditioner operate when the engine is running. The air

blower will operate even if the engine is turned off and the ignition switch is placed in the ON position.

NOTE:

- Odors from inside and outside the vehicle can build up in the air conditioner unit. Odor can enter the passenger compartment through the ventilators.
- When parking, set the heater and air conditioner controls to turn off air recirculation to allow fresh air into the passenger compartment. This should help reduce odors inside the vehicle.

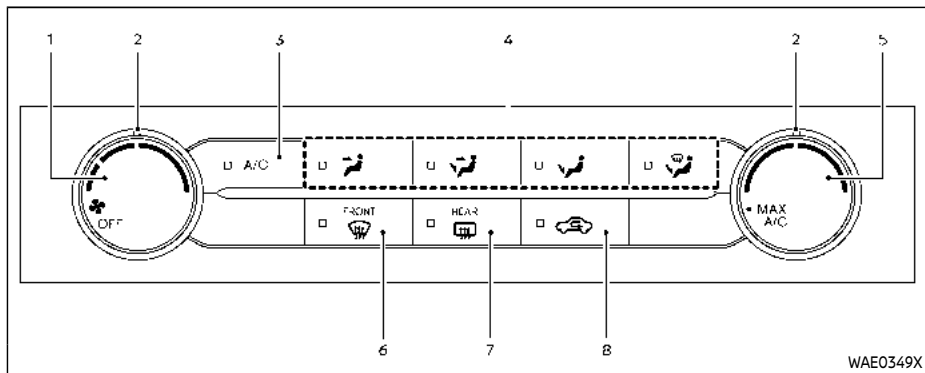

1. (fan speed control) dial
2. Dial pointers
3. A/C (air conditioner) button
4. Air flow control buttons
5. Temperature control dial
6. (front defroster) button
7. (rear window defroster) button (See "Rear window and outside mirror defroster switch" (P.2-57).)
8. (air recirculation) button

MANUAL AIR CONDITIONER AND HEATER

Controls

Turning system on/off:

To turn on the system, turn the dial out of the OFF position. Turn the dial counterclockwise to the OFF position to turn off the system.

Fan speed control:

Turn the dial clockwise to increase the fan speed.

Turn the dial counterclockwise to decrease the fan speed.

The dial pointer indicates the fan speed

level.

Temperature control:

Turn the temperature control dial to set the desired temperature. Turn the dial between the middle and the right position to select the hot temperature. Turn the dial between the middle and the left position to select the cool temperature. The dial pointer indicates the temperature level.

Air flow control:

Push one of the air flow control buttons to select the air flow outlets.

- Air flows mainly from center and side ventilators.
- Air flows mainly from center and side ventilators and foot outlets.
- Air flows mainly from the foot outlet and partly from the defroster.
- Air flows mainly from the defroster and foot outlets.

Air intake control:

The air intake control mode will change each time the button is pushed.

- When the indicator light is turned on, the air recirculates inside the vehicle.
- When the indicator light is turned off, the air flow is drawn from outside the vehicle.

A/C (Air Conditioner) operation:

Push the A/C button to turn on or off the air conditioner. When the air conditioner is on, the A/C indicator light on the button illuminates.

MAX A/C (Quick Air Conditioning) operation:

To turn on the MAX A/C mode for maximum cooling and dehumidifying, turn the temperature control dial counterclockwise until the dial pointer is at the "MAX A/C" position.

When the MAX A/C mode is turned on, the air flow mode indicator light will turn off with the air flow mode fixed at .



At the same time, the indicator light on the A/C button and the air recirculation mode will turn on.

To turn off the MAX A/C mode, turn the temperature control dial clockwise so that the dial pointer is out of the "MAX A/C" position. When the MAX A/C mode is turned off, most of the settings will return to the previous state, while the indicator light on the A/C button will stay on.

Heater operation



Heating:

This mode is used to direct heated air from the foot outlets. Some air also flows from the defroster outlets and the side ventilator outlets.

1. Push the  button for normal heating. (The indicator light will turn off.)
2. Push the  button. (The indicator light will turn on.)
3. Turn the  dial to the desired position.
4. Turn the temperature control dial to the desired position between the middle and the hot (right) position.



Ventilation:

This mode directs outside air from the side and center ventilators.

1. Push the  button. (The indicator light will turn off.)
2. Push the  button. (The indicator light will turn on.)
3. Turn the  dial to the desired position.
4. Turn the temperature control dial to the desired position.

Defrosting or defogging:

This mode directs the air to the defroster outlets to defrost/defog the windows.

1. Push the  button. (The indicator light will turn on.)
2. Turn the  dial to the desired position.
3. Turn the temperature control dial to the desired position between the middle and the hot (right) position.



To remove frost from the windshield quickly, turn the temperature control dial to the maximum hot (right) position and the  dial to the maximum position.

When the front defroster mode is selected, the air conditioner automatically turns on if the outside temperature is more than slightly above freezing. This dehumidifies the air which helps defog the windshield. The air recirculation indicator light automatically turns off, allowing outside air to be drawn into the passenger compartment to further improve the defogging performance. The recirculation mode cannot be activated in the front defroster mode.

Bi-level heating:



The bi-level mode directs warmed air to

the side and center ventilators and to the front and rear floor outlets.

1. Push the  button. (The indicator light will turn off.)
2. Push the  button. (The indicator light will turn on.)
3. Turn the  dial to the desired position.
4. Turn the temperature control dial to the desired position.

Heating and defogging:

This mode heats the interior and defogs the windows.

1. Push the  button. (The indicator light will turn on.)
2. Turn the  dial to the desired position.
3. Turn the temperature control dial to the maximum hot (right) position.

When the  button is pushed, the air conditioner automatically turns on if the outside temperature is more than slightly above freezing. This dehumidifies the air which helps defog the windshield. The air recirculation indicator light automatically turns off, allowing outside air to be drawn into the passenger compartment to further improve the defogging performance.

NOTE:



Clear snow and ice from the wiper blades and air inlet in front of the windshield. This improves heater operation.

Air conditioner operation

Start the engine, turn the  dial to the desired position, and push the A/C button to activate the air conditioner. When the air conditioner is on, cooling and dehumidifying functions are added to the heater operation. The air conditioner cooling function operates only when the engine is running.

Cooling:

This mode is used to cool and dehumidify the air.



1. Push the  button. (The indicator light will turn on.)
2. Turn the  dial to the desired position.
3. Push the A/C button. (The indicator light will turn on.)
4. Turn the temperature control dial to the desired position between the middle and the cool (left) position.

For quick cooling, turn on the MAX A/C mode by turning the temperature control dial until the dial pointer is at the "MAX A/C" position. When the MAX A/C mode is

turned on, it will activate the air recirculation mode. The amount of air coming through the ventilators is the highest it can go when in MAX A/C mode regardless of the position of the  dial.



Dehumidified heating:



This mode is used to heat and dehumidify the air.

1. Push the  button. (The indicator light will turn off.)
2. Push the  button. (The indicator light will turn on.)
3. Turn the  dial to the desired position.
4. Push the A/C button on. (The indicator light will turn on.)
5. Turn the temperature control dial to the desired position between the middle and the hot (right) position.



Dehumidified defogging:

This mode is used to defog the windows and dehumidify the air.

1. Push the  button. (The indicator light will turn on.)
2. Turn the  dial to the desired position.
3. Turn the temperature control dial to the desired position.

When the  or  mode is selected, the

air conditioner automatically turns on if the outside temperature is more than slightly above freezing. This dehumidifies the air which helps defog the windshield. The air recirculation mode automatically turns off, allowing outside air to be drawn into the passenger compartment to further improve the defogging performance.

The air conditioner is always turned on in the  or  mode, regardless of whether the indicator light is on or off.

NOTE:



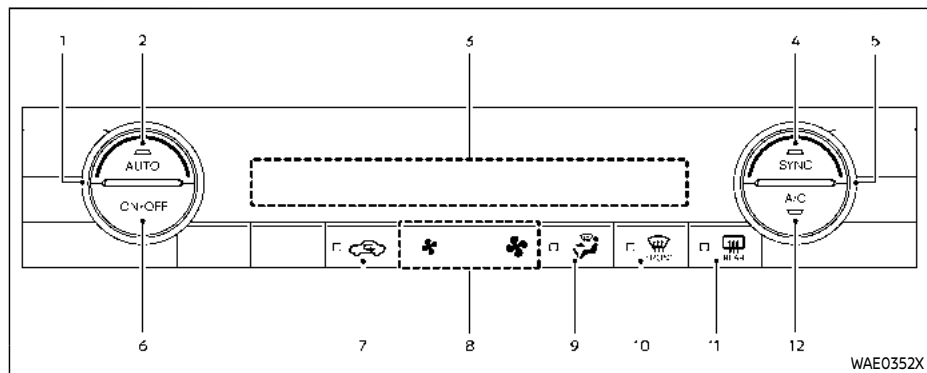

- **The air conditioner system should be operated for approximately 10 minutes at least once a month. This helps prevent damage to the air conditioner system due to the lack of lubrication.**
- **A visible mist may be seen coming from the ventilators in hot, humid conditions as the air is cooled rapidly. This does not indicate a malfunction.**
- **If the engine coolant temperature becomes too high, the air recirculation mode will be activated and the indicator light will turn on automatically.**
- **If the engine coolant temperature gauge indicates engine coolant temperature over the normal range, turn**

the air conditioner off. (See “If your vehicle overheats” (P.6-14).)



Models with heated steering wheel

WAE0352X

1. Temperature control dial (driver's side)
2. AUTO (automatic) button
3. Display screen
4. SYNC (synchronize) button
5. Temperature control dial (passenger's side)
6. ON-OFF button
7.  (air recirculation) button
8.  (fan speed control) buttons
9.  (air flow control) button
10.  (front defroster) button
11.  (rear window defroster) button
(See "Rear window and outside mirror defroster switch" (P.2-57).)
12. A/C (air conditioner) button

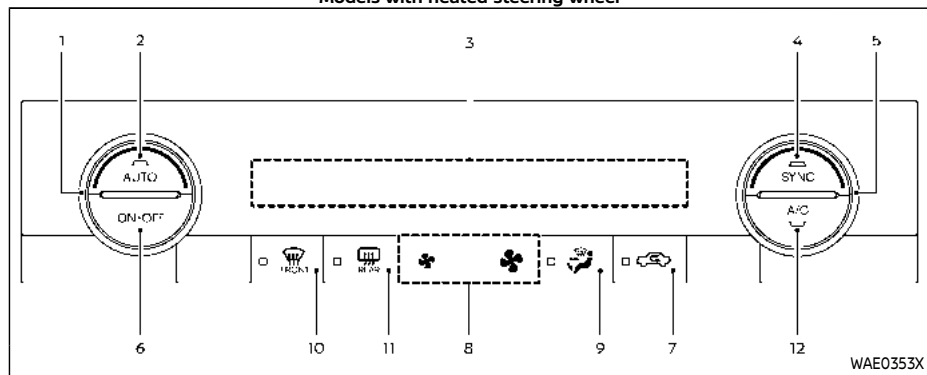

Models without heated steering wheel

WAE0353X

AUTOMATIC AIR CONDITIONER (models without rear control)

Automatic operation

Cooling and/or dehumidified heating (AUTO):

This mode may be used all year round as the system automatically works to keep a constant temperature. Air flow distribution and fan speed are also controlled automatically.

1. Push the AUTO button on. (The indicator light on the button will illuminate.)

2. Turn the temperature control dial on the corresponding side to set the desired temperature.
 - You can individually set temperatures for the driver's side and front passenger's side when the indicator light on the SYNC button is not illuminated.

A visible mist may be seen coming from the ventilators in hot, humid conditions as the air is cooled rapidly. This does not indicate a malfunction.

Heating (A/C OFF):

The air conditioner does not activate in this mode. Use this mode when you only need to heat.



1. Push the AUTO button on. (The indicator light on the button will illuminate.)
2. Push the A/C button. (The indicator light will turn off.)
3. Turn the temperature control dial on the corresponding side to set the desired temperature.
 - You can individually set temperatures for the driver's side and front passenger's side when the indicator light on the SYNC button is not illuminated.

- The temperature of the passenger compartment will be maintained automatically. Air flow distribution and fan speed are also controlled automatically.

NOTE:

- **Do not set the temperature lower than the outside air temperature or the system may not work properly.**
- **Not recommended if windows fog up.**

Dehumidified defrosting or defogging:

1. Push the  button. (The indicator light on the button will turn on.)
2. Turn the temperature control dial on the corresponding side to set the desired temperature.
 - To quickly remove ice from the outside of the windows, use the  button to set the fan speed to maximum.
 - As soon as possible after the windshield is clean, push the AUTO button to return to the automatic mode.
 - When the  button is pushed, the air conditioner will automatically be turned on at outside temperatures more than slightly above freezing. The air recirculation mode automatically turns off, allowing outside

air to be drawn into the passenger compartment to further improve the defogging performance.

Manual operation

Fan speed control:

Push the  buttons to manually control the fan speed.





Air intake control:

The air intake control mode will change each time the  button is pushed.

- When the indicator light is turned on, the air recirculates inside the vehicle.
- When the indicator light is turned off, the air flow is drawn from outside the vehicle.
- To switch to automatic control mode, push and hold the  button for about 2 seconds. The indicator light will blink, and then the air intake will be controlled automatically.

Air flow control:

Pushing the  button manually controls air flow and selects the air outlet:

-  – Air flows mainly from center and side ventilators.
-  – Air flows mainly from center and side ventilators and foot outlets.
-  – Air flows mainly from the foot outlet and partly from the defroster.
-  – Air flows mainly from the defroster and foot outlets.

Synchronize temperature settings:

Push the SYNC button to turn on the SYNC mode. (The indicator light on the button will turn on.)

When the SYNC mode is active, the driver's side temperature control dial will control the driver's and front passenger's side temperatures.

To exit the SYNC mode, change the passenger's side temperature using the temperature control dial on the front passenger's side. (The indicator light on the SYNC button will turn off.)

To turn the system off

Push the ON-OFF button.

Remote engine start logic (if so equipped)

When the remote engine start function is activated, the vehicles equipped with the automatic air conditioner and heater may go into automatic heating or cooling mode depending on the outside and cabin temperatures. During this period, the display and the buttons will be inoperable until the ignition switch is placed in the ON position. When the temperature is low, the rear defroster and the heated steering wheel (if so equipped) may also be activated automatically with the activation of the remote engine start function. (See "Remote engine start" (P.3-19).)

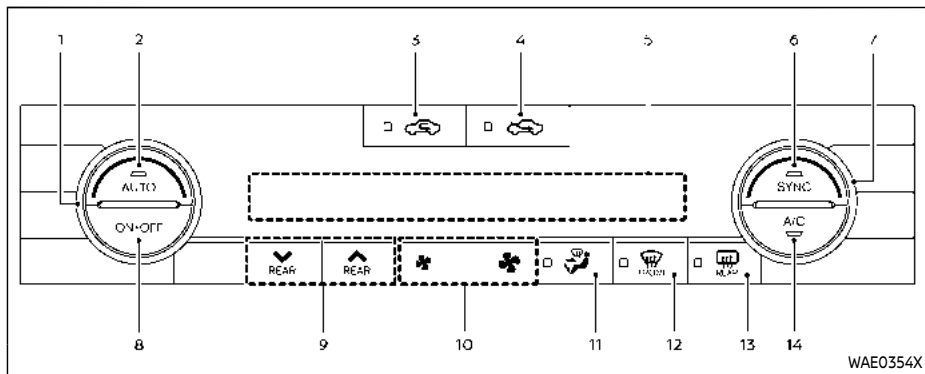

1. Temperature control dial (driver's side)
2. AUTO (automatic) button
3. (air recirculation) button
4. (outside air circulation) button
5. Display screen
6. SYNC (synchronize) button
7. Temperature control dial (passenger's side)
8. ON-OFF button
9. Rear temperature control buttons
10. (fan speed control) buttons
11. (air flow control) button
12. (front defroster) button
13. (rear window defroster) button
(See "Rear window and outside mirror defroster switch" (P.2-57).)

14. A/C (air conditioner) button

AUTOMATIC AIR CONDITIONER (models with rear control)

Automatic operation

Cooling and/or dehumidified heating (AUTO):

This mode may be used all year round as the system automatically works to keep a constant temperature. Air flow distribution and fan speed are also controlled automatically.

1. Push the AUTO button on. (The indicator light on the button will illuminate.)

2. Turn the temperature control dial on the corresponding side to set the desired temperature.

- You can individually set temperatures for the driver's side and front passenger's side when the indicator light on the SYNC button is not illuminated.

A visible mist may be seen coming from the ventilators in hot, humid conditions as the air is cooled rapidly. This does not indicate a malfunction.

Heating (A/C OFF):

The air conditioner does not activate in this mode. Use this mode when you only need to heat.



1. Push the AUTO button on. (The indicator light on the button will illuminate.)
2. Push the A/C button. (The indicator light will turn off.)
3. Turn the temperature control dial on the corresponding side to set the desired temperature.
 - You can individually set temperatures for the driver's side and front passenger's side when the indicator light on the SYNC button is not illuminated.

- The temperature of the passenger compartment will be maintained automatically. Air flow distribution and fan speed are also controlled automatically.

NOTE:

- **Do not set the temperature lower than the outside air temperature or the system may not work properly.**
- **Not recommended if windows fog up.**

Dehumidified defrosting or defogging:

1. Push the  button. (The indicator light on the button will come on.)
2. Turn the temperature control dial on the corresponding side to set the desired temperature.
 - To quickly remove ice from the outside of the windows, use the  button to set the fan speed to maximum.
 - As soon as possible after the windshield is clean, push the AUTO button to return to the automatic mode.
 - When the  button is pushed, the air conditioner will automatically be turned on at outside temperatures more than slightly above freezing. The air recirculation mode automatically turns off, allowing outside





air to be drawn into the passenger compartment to further improve the defogging performance.

Manual operation

Fan speed control:





Push the  buttons to manually control the fan speed.

Air intake control:

- Push the  button to recirculate interior air inside the vehicle. The indicator light on the button will come on.
- Push the  button to draw outside air into the passenger compartment. The indicator light on the button will come on.
- To control the air intake automatically, push and hold either the  button or the  button. The indicator light will blink, and then the air intake will switch to automatic control. When the automatic control is set, the system automatically alternates between the outside air circulation and the air recirculation modes. (The indicator light of the active mode will turn on.)

Air flow control:

Pushing the  button manually controls air flow and selects the air outlet:

-  — Air flows mainly from center and side ventilators.
-  — Air flows mainly from center and side ventilators and foot outlets.
-  — Air flows mainly from the foot outlet and partly from the defroster.
-  — Air flows mainly from the defroster and foot outlets.

Synchronize temperature settings:

Push the SYNC button to turn on the SYNC mode. (The indicator light on the button will turn on.)

When the SYNC mode is active, the driver's side temperature control dial will control the driver's side, front passenger's side and rear temperatures.

When the passenger's side temperature control dial or the rear temperature control buttons are operated, it will cancel the SYNC mode of the individual zone. (The indicator light on the SYNC button will remain on.)

Operating both the passenger's side temperature control dial and the rear temperature control buttons will turn off the SYNC mode. (The indicator light on the SYNC button will turn off.) (See "Rear temperature control" (P.4-37).)

To turn the system off
Push the ON-OFF button.

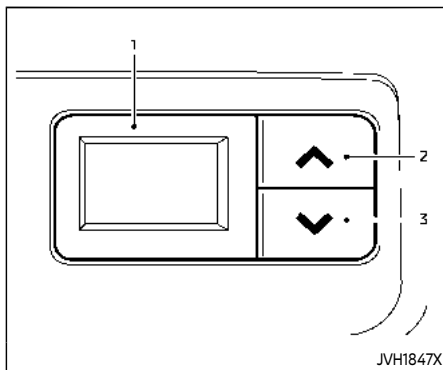

1. Rear temperature display
2. " ^ " Rear temperature increase button
3. " v " Rear temperature decrease button

Rear temperature control (if so equipped)

You can adjust the temperature for rear seat passengers using the buttons located on the back side of the console box.

Remote engine start logic

When the remote engine start function is activated, the vehicles equipped with the automatic air conditioner and heater may go into automatic heating or cooling mode depending on the outside and cabin temperatures. During this period,

the display and the buttons will be inoperable until the ignition switch is placed in the ON position. When the temperature is low, the rear defroster and the heated steering wheel (if so equipped) may also be activated automatically with the activation of the remote engine start function. (See "Remote engine start" (P.3-19).)

OPERATING TIPS (for automatic air conditioner)

When the engine coolant temperature and outside air temperature are low, the air flow from the foot outlets may be limited when in the automatic mode. However, this is not a malfunction. After the coolant temperature warms up, air flow from the foot outlets will operate normally.

For rear temperature control (if so equipped):

- The purpose of the rear temperature control is to vary the temperature of the rear airflow.
- The amount of airflow to the rear ventilators is primarily controlled by the front passenger's blower and mode settings.
- The amount of airflow to the rear ventilators is also affected by the rear temperature setting. Higher rear tem-

perature settings have lower airflow amounts than cooler temperature settings. This condition ensures better comfort to the head and face area, while primary heating for the rear passenger seats is provided through the foot outlets.

Sensors:

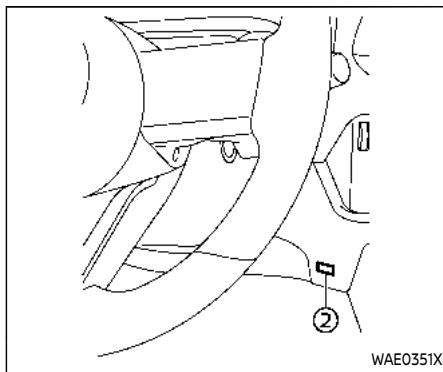
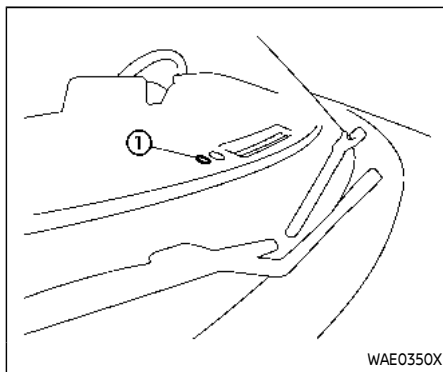

The sensors ① and ②, located on the

instrument panel, help maintain a constant temperature. Do not put anything on or around the sensors.

SERVICING AIR CONDITIONER



WARNING

The air conditioner system contains refrigerant under high pressure. To avoid personal injury, any air conditioner service should be done only by an experienced technician with the proper equipment.

The air conditioner system in your vehicle is charged with a refrigerant designed with the environment in mind.

This refrigerant will not harm the earth's ozone layer. However, it may contribute in a small part to global warming.

Special charging equipment and lubricant are required when servicing your vehicle's air conditioner. Using improper refrigerants or lubricants will cause severe damage to the air conditioner system. (See "Air conditioning system refrigerant and lubricant recommendations" (P.10-8).)

A NISSAN dealer will be able to service your environmentally friendly air condi-

tioner system.

In-cabin microfilter

The air conditioner system is equipped with an in-cabin microfilter. To make sure the air conditioner heats, defogs, and ventilates efficiently, replace the filter according to the specified maintenance intervals listed in the "9. Maintenance and schedules" section. It is recommended to visit a NISSAN dealer to replace the filter.

The filter should be replaced if the air flow decreases significantly or if windows fog up easily when operating the heater or air conditioner.

RADIO ANTENNA

The antenna is located on the rear part of the vehicle roof.



CAUTION

- **A build up of ice on the antenna can affect radio performance. Remove the ice to restore radio reception.**
- **When removing snow from the roof, do not apply strong force to the antenna. That may cause broken antenna and roof panel dent.**
- **When using a high pressure car wash, keep the high pressure nozzle away from the antenna. The seal may be deformed or damaged.**
- **The radio performance may be affected if cargo carried on the roof blocks the radio signal. If possible, do not put cargo near the antenna.**

CAR PHONE OR CB RADIO

When installing a car phone or a CB radio in your vehicle, be sure to observe the following precautions, otherwise the new equipment may adversely affect the electronic control modules and electronic control system harness.



WARNING

- **A cellular phone should not be used for any purpose while driving so full attention may be given to vehicle operation. Some jurisdictions prohibit the use of cellular phones while driving.**
- **If you must make a call while your vehicle is in motion, the hands-free cellular phone operational mode (if so equipped) is highly recommended. Exercise extreme caution at all times so full attention may be given to vehicle operation.**
- **If a conversation in a moving vehicle requires you to take notes, pull off the road to a safe location and stop your vehicle before doing so.**



CAUTION

- **Keep the antenna as far away as possible from the electronic control modules.**
- **Keep the antenna wire more than 8 in (20 cm) away from the electronic control system harness. Do not route the antenna wire next to any harness.**
- **Adjust the antenna standing-wave ratio as recommended by the manufacturer.**
- **Connect the ground wire from the CB radio chassis to the body.**
- **For details, it is recommended you visit a NISSAN dealer.**

5 Starting and driving

Precautions when starting and driving	5-5	Parking brake	5-25
Exhaust gas (carbon monoxide)	5-5	Automatic operation	5-26
Three-way catalyst	5-6	Manual operation	5-27
Turbocharger system (if so equipped)	5-6	Automatic brake hold	5-28
Tire Pressure Monitoring System (TPMS)	5-6	How to activate/deactivate the automatic brake hold function	5-29
Avoiding collision and rollover	5-10	How to use the automatic brake hold function	5-30
On-pavement and off-road driving precautions	5-10	Drive Mode Selector	5-31
Off-road recovery	5-11	OFF-ROAD mode (AWD models)	5-32
Rapid air pressure loss	5-11	SNOW mode (AWD models)	5-32
Drinking alcohol/drugs and driving	5-12	STANDARD mode (2WD models)/AUTO mode (AWD models)	5-32
Driving safety precautions	5-12	ECO mode	5-32
Push-button ignition switch	5-14	SPORT mode	5-34
Operating range for engine start function	5-15	Driver Assistance systems	5-35
Push-button ignition switch operation	5-15	How to enable/disable the systems	5-38
Push-button ignition switch positions	5-16	Common troubleshooting guide	5-40
Emergency engine shut off	5-16	Traffic Sign Recognition (TSR) (if so equipped)	5-44
Intelligent Key battery discharge	5-17	System operation	5-44
Before starting the engine	5-17	How to enable/disable the TSR system	5-46
Starting the engine	5-18	System temporarily unavailable	5-46
Remote engine start (if so equipped)	5-18	System malfunction	5-46
Driving the vehicle	5-19	System maintenance	5-47
Continuously Variable Transmission (CVT)	5-19		

Lane Departure Warning (LDW)	5-47	System temporarily unavailable	5-75
LDW system operation	5-48	System malfunction	5-75
How to enable/disable the LDW system	5-49	System maintenance	5-76
LDW system limitations	5-49	Rear Cross Traffic Alert (RCTA)	5-77
System temporarily unavailable	5-50	RCTA system operation	5-77
System malfunction	5-51	How to enable/disable the RCTA system	5-79
System maintenance	5-51	RCTA system limitations	5-80
Intelligent Lane Intervention (I-LI) (if so equipped)	5-52	System temporarily unavailable	5-82
I-LI system operation	5-53	System malfunction	5-82
How to enable/disable the I-LI system	5-54	System maintenance	5-82
I-LI system limitations	5-54	Cruise control (if so equipped)	5-83
System temporarily unavailable	5-56	Precautions on cruise control	5-84
System malfunction	5-56	Cruise control operations	5-84
System maintenance	5-57	ProPILOT Assist (if so equipped)	5-85
Blind Spot Warning (BSW)	5-58	ProPILOT Assist system operation	5-87
BSW system operation	5-59	ProPILOT Assist switches	5-89
How to enable/disable the BSW system	5-60	ProPILOT Assist system display and indicators	5-90
BSW system limitations	5-60	Turning the conventional (fixed speed) cruise control mode ON	5-92
BSW driving situations	5-61	Operating ProPILOT Assist	5-92
System temporarily unavailable	5-64	How to enable/disable the Steering Assist	5-97
System malfunction	5-64	How to cancel the ProPILOT Assist system	5-98
System maintenance	5-65	Intelligent Cruise Control (ICC)	5-98
Intelligent Blind Spot Intervention (I-BSI) (if so equipped)	5-66	Steering Assist	5-113
I-BSI system operation	5-67	Conventional (fixed speed) cruise control mode	5-119
How to enable/disable the I-BSI system	5-69		
I-BSI system limitations	5-69		
I-BSI driving situations	5-71		

Automatic Emergency Braking (AEB) with Pedestrian Detection system	5-122	System maintenance	5-148
AEB with Pedestrian Detection system operation	5-123	Break-in schedule	5-149
Turning the AEB with Pedestrian Detection system ON/OFF	5-125	Fuel Efficient Driving Tips	5-149
AEB with Pedestrian Detection system limitations	5-126	Increasing fuel economy	5-150
System temporarily unavailable	5-129	Intelligent 4x4 (if so equipped)	5-151
System malfunction	5-130	Parking/parking on hills	5-153
System maintenance	5-131	Electric power steering	5-154
Intelligent Forward Collision Warning (I-FCW)	5-132	Brake system	5-155
I-FCW system operation	5-134	Braking precautions	5-155
Turning the I-FCW system ON/OFF	5-135	Brake assist	5-156
I-FCW system limitations	5-137	Brake assist	5-156
System temporarily unavailable	5-138	Anti-lock Braking System (ABS)	5-156
System malfunction	5-139	Vehicle Dynamic Control (VDC) system	5-157
System maintenance	5-139	How to turn off the VDC system	5-158
Intelligent Driver Alertness (I-DA)	5-141	Brake Force Distribution	5-159
I-DA system operation	5-141	Chassis control	5-160
How to enable/disable the I-DA system	5-142	Intelligent Trace Control	5-160
I-DA system limitations	5-142	Active Ride Control	5-160
System malfunction	5-143	Hill Start Assist system	5-161
Rear Automatic Braking (RAB)	5-143	Sonar system (if so equipped)	5-162
RAB system operation	5-145	System operation	5-163
Turning the RAB system ON/OFF	5-145	How to enable/disable the sonar system	5-165
RAB system limitations	5-146	Sonar system limitations	5-166
System malfunction	5-148	System temporarily unavailable	5-167
		System maintenance	5-167
		Rear Sonar System (RSS) (if so equipped)	5-168
		System operation	5-168
		How to enable/disable the RSS	5-170

RSS limitations	5-171	Tire equipment	5-173
System temporarily unavailable	5-171	Special winter equipment	5-173
System maintenance	5-172	Driving on snow or ice	5-173
Cold weather driving	5-173	Active noise cancellation (if so equipped)/	
Freeing a frozen door lock	5-173	Active sound enhancement (if	
Anti-freeze	5-173	so equipped)	5-174
Battery	5-173	Active noise cancellation	5-175
Draining of coolant water	5-173	Active sound enhancement	5-175

PRECAUTIONS WHEN STARTING AND DRIVING



WARNING

- Do not leave children or adults who would normally require the support of others alone in your vehicle. Pets should not be left alone either. They could accidentally injure themselves or others through inadvertent operation of the vehicle. Also, on hot, sunny days, temperatures in a closed vehicle could quickly become high enough to cause severe or possibly fatal injuries to people or animals.
- Properly secure all cargo with ropes or straps to help prevent it from sliding or shifting. Do not place cargo higher than the seat-backs. In a sudden stop or collision, unsecured cargo could cause personal injury.

EXHAUST GAS (carbon monoxide)



WARNING

- Do not breathe exhaust gas; it contains colorless and odorless carbon monoxide. Carbon mon-

oxide is dangerous. It can cause unconsciousness or death.

- If you suspect that exhaust fumes are entering the vehicle, drive with all windows fully open, and have the vehicle inspected immediately.
- Do not run the engine in closed spaces such as a garage.
- Do not park the vehicle with the engine running for an extended period of time.
- Keep the liftgate closed while driving, otherwise exhaust gas could be drawn into the passenger compartment. If you must drive with the liftgate open, follow these precautions:
 - Open all the windows.
 - Turn the air recirculation mode off and set the fan speed control to the highest level to circulate the air.
- If a special body or other equipment is added for recreational or other usage, follow the manufacturer's recommendation to prevent carbon monoxide entry into the vehicle. (Some recreational vehicle appliances such as stoves,

refrigerators, heaters, etc. may also generate carbon monoxide.)

- If electrical wiring or other cable connections must pass to a trailer through the seal on the liftgate or the body, follow the manufacturer's recommendation to prevent carbon monoxide entry into the vehicle.
- The exhaust system and body should be inspected by a qualified mechanic whenever:
 - Your vehicle is raised while being serviced.
 - You suspect that exhaust fumes are entering into the passenger compartment.
 - You notice a change in the sound of the exhaust system.
 - You have had an accident involving damage to the exhaust system, underbody, or rear of the vehicle.

THREE-WAY CATALYST

The three-way catalyst is an emission control device installed in the exhaust system. Exhaust gases in the three-way catalyst are burned at high temperatures to help reduce pollutants.

WARNING

- The exhaust gas and the exhaust system are very hot. Keep people, animals and flammable materials away from the exhaust system components.
- Do not stop or park the vehicle over flammable materials such as dry grass, wastepaper or rags. They may ignite and cause a fire.

CAUTION

- Do not use leaded gasoline. Deposits from leaded gasoline will seriously reduce the three-way catalyst's ability to help reduce exhaust pollutants.
- Keep your engine tuned up. Malfunctions in the ignition, fuel injection, or electrical systems can

cause overrich fuel flow into the three-way catalyst, causing it to overheat. Do not keep driving if the engine misfires, or if noticeable loss of performance or other unusual operating conditions are detected. Have the vehicle inspected. It is recommended you visit a NISSAN dealer for this service.

- Avoid driving with an extremely low fuel level. Running out of fuel could cause the engine to misfire, damaging the three-way catalyst.
- Do not race the engine while warming it up.
- Do not push or tow your vehicle to start the engine.

TURBOCHARGER SYSTEM (if so equipped)

The turbocharger system uses engine oil for lubrication and cooling of its rotating components. The turbocharger turbine turns at extremely high speeds and it can reach an extremely high temperature. It is essential to maintain a clean supply of oil flowing through the turbocharger system. A sudden interruption of oil supply may cause a malfunction in the turbocharger.

To ensure prolonged life and performance of the turbocharger, it is essential to comply with the following maintenance procedure.

CAUTION

- Change your engine oil according to the recommended intervals shown in the "Maintenance and schedules" (P.9-1).
- Use only the recommended engine oil. (See "Capacities and recommended fluids/lubricants" (P.10-3).)
- If the engine has been operating at high rpm for an extended period of time, let it idle for a few minutes prior to turn off.
- Do not accelerate your engine to high rpm immediately after starting it.

TIRE PRESSURE MONITORING SYSTEM (TPMS)

Each tire, including the spare, should be checked monthly when cold and inflated to the inflation pressure recommended by the vehicle manufacturer on the vehicle placard or tire inflation pressure

label. (If your vehicle has tires of a different size than the size indicated on the vehicle placard or tire inflation pressure label, you should determine the proper tire inflation pressure for those tires.)

As an added safety feature, your vehicle has been equipped with a Tire Pressure Monitoring System (TPMS) that illuminates a low tire pressure telltale when one or more of your tires is significantly under-inflated. Accordingly, when the low tire pressure telltale illuminates, you should stop and check your tires as soon as possible, and inflate them to the proper pressure. Driving on a significantly under-inflated tire causes the tire to overheat and can lead to tire failure. Under-inflation also reduces fuel efficiency and tire tread life, and may affect the vehicle's handling and stopping ability.

Please note that the TPMS is not a substitute for proper tire maintenance, and it is the driver's responsibility to maintain correct tire pressure, even if under-inflation has not reached the level to trigger illumination of the TPMS low tire pressure telltale.

Your vehicle has also been equipped with a TPMS malfunction indicator to indicate when the system is not operating prop-

erly. The TPMS malfunction indicator is combined with the low tire pressure telltale. When the system detects a malfunction, the telltale will flash for approximately one minute and then remain continuously illuminated. This sequence will continue upon subsequent vehicle start-ups as long as the malfunction exists. When the malfunction indicator is illuminated, the system may not be able to detect or signal low tire pressure as intended. TPMS malfunctions may occur for a variety of reasons, including the installation of replacement or alternate tires or wheels on the vehicle that prevent the TPMS from functioning properly. Always check the TPMS malfunction telltale after replacing one or more tires or wheels on your vehicle to ensure that the replacement or alternate tires and wheels allow the TPMS to continue to function properly.

Additional information

- Since the spare tire is not equipped with the TPMS, the TPMS does not monitor the tire pressure of the spare tire.
- The TPMS will activate only when the vehicle is driven at speeds above 16 MPH (25 km/h). Also, this system may not detect a sudden drop in tire pressure (for example a flat tire while

driving).

- The low tire pressure warning light does not automatically turn off when the tire pressure is adjusted. After the tire is inflated to the recommended pressure, the vehicle must be driven at speeds above 16 MPH (25 km/h) to activate the TPMS and turn off the low tire pressure warning light. Use a tire pressure gauge to check the tire pressure.
- The "Tire Pressure Low - Add Air" warning appears in the vehicle information display when the low tire pressure warning light is illuminated and low tire pressure is detected. The "Tire Pressure Low - Add Air" warning turns off when the low tire pressure warning light turns off.
The "Tire Pressure Low - Add Air" warning does not appear if the low tire pressure warning light illuminates to indicate a TPMS malfunction.
- Tire pressure rises and falls depending on the heat caused by the vehicle's operation and the outside temperature. Do not reduce the tire pressure after driving because the tire pressure rises after driving. Low outside temperature can lower the temperature of the air inside the tire which can cause a lower tire inflation pressure.

This may cause the low tire pressure warning light to illuminate. If the warning light illuminates in low ambient temperature, check the tire pressure for all four tires.

- You can also check the tire pressure of all tires (except the spare tire) in the vehicle information display. (See “Trip computer” (P.2-47).)

For additional information, see “Low tire pressure warning light” (P.2-18) and “Tire Pressure Monitoring System (TPMS)” (P.6-3).



WARNING

- **If the low tire pressure warning light illuminates while driving, avoid sudden steering maneuvers or abrupt braking, reduce vehicle speed, pull off the road to a safe location and stop the vehicle as soon as possible. Driving with under-inflated tires may permanently damage the tires and increase the likelihood of tire failure. Serious vehicle damage could occur and may lead to an accident and could result in serious personal injury. Check the tire pressure for all four tires. Adjust the tire pressure to the**

recommended COLD tire pressure shown on the Tire and Loading Information label to turn the low tire pressure warning light OFF. If you have a flat tire, replace it with a spare tire as soon as possible. (See “Flat tire” (P.6-3) for changing a flat tire.)

- **Since the spare tire is not equipped with the TPMS, when a spare tire is mounted or a wheel is replaced, the TPMS will not function and the low tire pressure warning light will flash for approximately 1 minute. The light will remain on after 1 minute. Have your tires replaced and/or TPMS system reset as soon as possible. It is recommended you visit a NISSAN dealer for these services.**
- **Replacing tires with those not originally specified by NISSAN could affect the proper operation of the TPMS.**
- **Do not inject any tire liquid or aerosol tire sealant into the tires, as this may cause a malfunction of the tire pressure sensors.**



CAUTION

- **The TPMS may not function properly when the wheels are equipped with tire chains or the wheels are buried in snow.**
- **Do not place metalized film or any metal parts (antenna, etc.) on the windows. This may cause poor reception of the signals from the tire pressure sensors, and the TPMS will not function properly.**

Some devices and transmitters may temporarily interfere with the operation of the TPMS and cause the low tire pressure warning light to illuminate. Some examples are:

- Facilities or electric devices using similar radio frequencies are near the vehicle.
- If a transmitter set to similar frequencies is being used in or near the vehicle.
- If a computer (or similar equipment) or a DC/AC converter is being used in or near the vehicle.

Low tire pressure warning light may illuminate in the following cases.

- If the vehicle is equipped with a wheel and tire without TPMS.
- If the TPMS has been replaced and the ID has not been registered.
- If the wheel is not originally specified by NISSAN.

FCC Notice:

For USA:

Tire Pressure Monitoring System (TPMS) transmitter

FCC ID: KR5TIS-10DL

Body Control Module (BCM)



40406556

Continental

This device complies with Part 15 of the FCC Rules. Operation is subject to the following two conditions: (1) This device may not cause harmful interference, and (2) this device must accept any interference received, including interference that may cause undesired operation.

Note: Changes or modifications not expressly approved by the party responsible for compliance could void the user's authority to operate the equipment.

For Canada:

Tire Pressure Monitoring System (TPMS) transmitter

Continental

Model: TIS-10DL

IC: 7812D-TIS10DL

Body Control Module (BCM)

Model: 40406556

IC: 7812D-5235RXP

Continental

This device complies with Industry Canada licence-exempt RSS standard(s). Operation is subject to the following two conditions: (1) this device may not cause interference, and (2) this device must accept any interference, including interference that may cause undesired operation of the device.

TPMS with Easy Fill Tire Alert



WARNING

After rotating the tires, do not use the Easy-Fill Tire Alert to adjust the tire pressure. Instead use a gauge to adjust the tires to the correct pressure in accordance with Tire and

Loading Information label.

When adding air to an under-inflated tire, the TPMS with Easy Fill Tire Alert provides visual and audible signals outside the vehicle to help you inflate the tires to the recommended COLD tire pressure.

Vehicle set-up:

1. Park the vehicle in a safe and level place.
2. Apply the parking brake and push the park button to shift to the P (Park) position.
3. Place the ignition switch in the ON position. Do not start the engine.

Operation:

1. Add air to the tire.
 2. After a few seconds, the hazard indicators will start flashing.
 3. When the designated pressure is reached, the horn beeps once and the hazard indicators stop flashing.
 4. Perform the above steps for each tire.
- If the tire is over-inflated more than approximately 4 psi (30 kPa), the horn beeps and the hazard indicators flash 3 times. To correct the pressure, push the core of the valve stem on the tire briefly to release pressure. When the

pressure reaches the designated pressure, the horn beeps once.

- If the hazard indicator does not flash within approximately 15 seconds after starting to inflate the tire, it indicates that the TPMS with Easy Fill Tire Alert is not operating.
- The TPMS will not activate the Easy Fill Tire Alert under the following conditions:
 - If there is interference from an external device or transmitter
 - The air pressure from the inflation device such as those using a power socket is not sufficient to inflate the tire
 - If an electrical equipment is being used in or near the vehicle
 - There is a malfunction in the TPMS system
 - There is a malfunction in the horn or hazard indicators
- If the TPMS with Easy Fill Tire Alert does not operate due to TPMS interference, move the vehicle about 3 ft (1m) backward or forward and try again.

If the TPMS with Easy Fill Tire Alert is not working, use a tire pressure gauge.

AVOIDING COLLISION AND ROLL-OVER



WARNING

Failure to operate this vehicle in a safe and prudent manner may result in loss of control or an accident.

Be alert and drive defensively at all times. Obey all traffic regulations. Avoid excessive speed, high speed cornering, or sudden steering maneuvers, because these driving practices could cause you to lose control of your vehicle. **As with any vehicle, a loss of control could result in a collision with other vehicles or objects, or cause the vehicle to roll-over, particularly if the loss of control causes the vehicle to slide sideways.** Be attentive at all times, and avoid driving when tired. Never drive when under the influence of alcohol or drugs (including prescription or over-the-counter drugs which may cause drowsiness). Always wear your seat belt as outlined in "Seat belts" (P.1-15) of this manual, and also instruct your passengers to do so.

Seat belts help reduce the risk of injury in collisions and rollovers. **In a rollover crash, an unbelted or improperly belted**

person is significantly more likely to be injured or killed than a person properly wearing a seat belt.

ON-PAVEMENT AND OFF-ROAD DRIVING PRECAUTIONS

Utility vehicles have a significantly higher rollover rate than other types of vehicles.

They have higher ground clearance than passenger cars to make them capable of performing in a variety of on-pavement and off-road applications. This gives them a higher center of gravity than ordinary cars. An advantage of higher ground clearance is a better view of the road, allowing you to anticipate problems. However, they are not designed for cornering at the same speeds as conventional passenger cars any more than low-slung sports cars are designed to perform satisfactorily under off-road conditions. If at all possible, avoid sharp turns or abrupt maneuvers, particularly at high speeds. As with other vehicles of this type, failure to operate this vehicle correctly may result in loss of control or vehicle rollover. Seat belts help reduce the risk of injury in collisions and rollovers. In a rollover crash, an unbelted or improperly belted person is significantly more likely to be injured or killed than a person properly wearing a seat belt.

Be sure to read "Driving safety precautions" (P.5-12).

OFF-ROAD RECOVERY

If the right side or left side wheels leave the road surface, maintain control of the vehicle by following the procedure below. Please note that this procedure is only a general guide. The vehicle must be driven as appropriate based on the conditions of the vehicle, road and traffic.

1. Remain calm and do not overreact.
2. Do not apply the brakes.
3. Maintain a firm grip on the steering wheel with both hands and try to hold a straight course.
4. When appropriate, slowly release the accelerator pedal to gradually slow the vehicle.
5. If there is nothing in the way, steer the vehicle to follow the road while the vehicle speed is reduced. Do not attempt to drive the vehicle back onto the road surface until vehicle speed is reduced.
6. When it is safe to do so, gradually turn the steering wheel until both tires return to the road surface. When all tires are on the road surface, steer the vehicle to stay in the appropriate driving lane.

- If you decide that it is not safe to return the vehicle to the road surface based on vehicle, road or traffic conditions, gradually slow the vehicle to a stop in a safe place off the road.

RAPID AIR PRESSURE LOSS

Rapid air pressure loss or a "blow-out" can occur if the tire is punctured or is damaged due to hitting a curb or pothole. Rapid air pressure loss can also be caused by driving on under-inflated tires.

Rapid air pressure loss can affect the handling and stability of the vehicle, especially at highway speeds.

Help prevent rapid air pressure loss by maintaining the correct air pressure and visually inspect the tires for wear and damage. See "Wheels and tires" (P.8-30) of this manual.

If a tire rapidly loses air pressure or "blows-out" while driving, maintain control of the vehicle by following the procedure below. Please note that this procedure is only a general guide. The vehicle must be driven as appropriate based on the conditions of the vehicle, road and traffic.



WARNING

The following actions can increase the chance of losing control of the vehicle if there is a sudden loss of tire air pressure. Losing control of the vehicle may cause a collision and result in personal injury.

- **The vehicle generally moves or pulls in the direction of the flat tire.**
 - **Do not rapidly apply the brakes.**
 - **Do not rapidly release the accelerator pedal.**
 - **Do not rapidly turn the steering wheel.**
1. Remain calm and do not overreact.
 2. Maintain a firm grip on the steering wheel with both hands and try to hold a straight course.
 3. When appropriate, slowly release the accelerator pedal to gradually slow the vehicle.
 4. Gradually steer the vehicle to a safe location off the road and away from traffic if possible.

5. Lightly apply the brake pedal to gradually stop the vehicle.
6. Turn on the hazard warning flashers and either contact a roadside emergency service to change the tire or see "Changing a flat tire" (P.6-4) of this Owner's Manual.

DRINKING ALCOHOL/DRUGS AND DRIVING



WARNING

Never drive under the influence of alcohol or drugs. Alcohol in the bloodstream reduces coordination, delays reaction time and impairs judgement. Driving after drinking alcohol increases the likelihood of being involved in an accident injuring yourself and others. Additionally, if you are injured in an accident, alcohol can increase the severity of the injury.

NISSAN is committed to safe driving. However, you must choose not to drive under the influence of alcohol. Every year thousands of people are injured or killed in alcohol-related accidents. Although the local laws vary on what is considered to be legally intoxicated, the fact is that

alcohol affects all people differently and most people underestimate the effects of alcohol.

Remember, drinking and driving don't mix! And that is true for drugs, too (over-the-counter, prescription, and illegal drugs). Don't drive if your ability to operate your vehicle is impaired by alcohol, drugs, or some other physical condition.

DRIVING SAFETY PRECAUTIONS

Your vehicle is designed for both normal and off-road use. However, avoid driving in deep water or mud as your vehicle is mainly designed for leisure use, unlike a conventional off-road vehicle.

Remember that Two-Wheel Drive (2WD) models are less capable than All-Wheel Drive (AWD) models for rough road driving and extrication when stuck in deep snow, mud, or the like.

Please observe the following precautions:



WARNING

- **Drive carefully when off the road and avoid dangerous areas. Every person who drives or rides in this vehicle should be seated with their seat belt fastened. This will keep you and your passengers in**

position when driving over rough terrain.

- **Do not drive across steep slopes. Instead drive either straight up or straight down the slopes. Off-road vehicles can tip over sideways much more easily than they can forward or backward.**
- **Many hills are too steep for any vehicle. If you drive up them, you may stall. If you drive down them, you may not be able to control your speed. If you drive across them, you may roll over.**
- **Do not shift ranges while driving on downhill grades as this could cause loss of control of the vehicle.**
- **Stay alert when driving to the top of a hill. At the top there could be a drop-off or other hazard that could cause an accident.**
- **If your engine stalls or you cannot make it to the top of a steep hill, never attempt to turn around. Your vehicle could tip or roll over. Always back straight down in R (Reverse) range. Never back down in N (Neutral), using only the brake, as this could cause loss of control.**

- Heavy braking going down a hill could cause your brakes to over-heat and fade, resulting in loss of control and an accident. Apply brakes lightly and use a low range to control your speed.
- Unsecured cargo can be thrown around when driving over rough terrain. Properly secure all cargo so it will not be thrown forward and cause injury to you or your passengers.
- To avoid raising the center of gravity excessively, do not exceed the rated capacity of the roof rack (if so equipped) and evenly distribute the load. Secure heavy loads in the cargo area as far forward and as low as possible. Do not equip the vehicle with tires larger than specified in this manual. This could cause your vehicle to roll over.
- Do not grip the inside or spokes of the steering wheel when driving off-road. The steering wheel could move suddenly and injure your hands. Instead drive with your fingers and thumbs on the outside of the rim.

- Before operating the vehicle, ensure that the driver and all passengers have their seat belts fastened.
- Always drive with the floor mats in place as the floor may become hot.
- Lower your speed when encountering strong crosswinds. With a higher center of gravity, your vehicle is more affected by strong side winds. Slower speeds ensure better vehicle control.
- Do not drive beyond the performance capability of the tires, even with AWD engaged.
- For AWD equipped vehicles, do not attempt to raise two wheels off the ground and shift the transmission to any drive or reverse position with the engine running. Doing so may result in drivetrain damage or unexpected vehicle movement which could result in serious vehicle damage or personal injury.
- Do not attempt to test an AWD equipped vehicle on a 2-wheel dynamometer (such as the dynamometers used by some states for emissions testing), or

similar equipment even if the other two wheels are raised off the ground. Make sure you inform test facility personnel that your vehicle is equipped with AWD before it is placed on a dynamometer. Using the wrong test equipment may result in drivetrain damage or unexpected vehicle movement which could result in serious vehicle damage or personal injury.

- When a wheel is off the ground due to an unlevel surface, do not spin the wheel excessively (AWD model).
- Accelerating quickly, sharp steering maneuvers or sudden braking may cause loss of control.
- If at all possible, avoid sharp turning maneuvers, particularly at high speeds. Your vehicle has a higher center of gravity than a conventional passenger car. The vehicle is not designed for cornering at the same speeds as conventional passenger cars. Failure to operate this vehicle correctly could result in loss of control and/or a rollover accident.

- Always use tires of the same type, size, brand, construction (bias, bias-belted or radial), and tread pattern on all four wheels. Install traction devices on the front wheels when driving on slippery roads and drive carefully.
- Be sure to check the brakes immediately after driving in mud or water. See “Brake system” (P.5-155) for wet brakes.
- Avoid parking your vehicle on steep hills. If you get out of the vehicle and it rolls forward, backward or sideways, you could be injured.
- Whenever you drive off-road through sand, mud or water as deep as the wheel hub, more frequent maintenance may be required. See the maintenance schedule shown in the “9. Maintenance and schedules” section.
- Spinning the front wheels on slippery surfaces may cause the AWD warning message to display and the AWD system to automatically switch from the AWD mode to the 2WD mode. This could reduce traction. Be especially careful when towing a trailer

(AWD models).

PUSH-BUTTON IGNITION SWITCH



WARNING

Do not operate the push-button ignition switch while driving the vehicle except in an emergency. (The engine will stop when the ignition switch is pushed 3 consecutive times or the ignition switch is pushed and held for more than 2 seconds.) If the engine stops while the vehicle is being driven, this could lead to a crash and serious injury.

Before operating the push-button ignition switch, be sure to push the park button to shift to the P (Park) position.

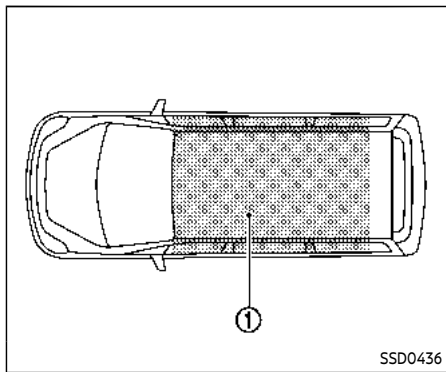

OPERATING RANGE FOR ENGINE START FUNCTION

The Intelligent Key can only be used for starting the engine when the Intelligent Key is within the specified operating range ①.

When the Intelligent Key battery is almost discharged or strong radio waves are present near the operating location, the Intelligent Key system's operating range becomes narrower and may not function properly.

If the Intelligent Key is within the operating range, it is possible for anyone, even someone who does not carry the Intelligent Key, to push the ignition switch to

start the engine.

- The cargo room area is not included in the operating range but the Intelligent Key may function.
- If the Intelligent Key is placed on the instrument panel, inside the glove box or door pocket, the Intelligent Key may not function.
- If the Intelligent Key is placed near the door or window outside the vehicle, the Intelligent Key may function.

If the battery of the Intelligent Key is discharged, see "Intelligent Key battery discharge" (P.5-17).

PUSH-BUTTON IGNITION SWITCH OPERATION



CAUTION

- **Do not leave the vehicle for extended periods of time when the ignition switch is in the ON position and the engine is not running. This can discharge the battery.**
- **Use electrical accessories with the engine running to avoid discharging the vehicle battery. If you must use accessories while the engine is not running, do not**

use them for extended periods of time and do not use multiple electrical accessories at the same time.

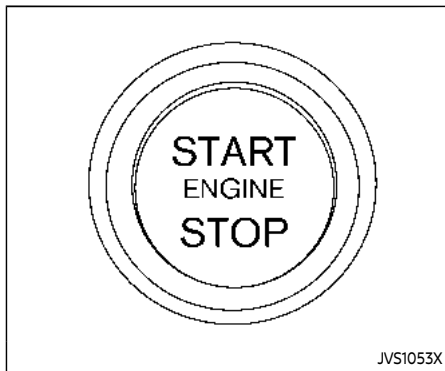

When the ignition switch is pushed without depressing the brake pedal, the ignition switch will illuminate.

Push the ignition switch center:

- once to change to ON.
- two times to change to OFF.

When the ignition switch cannot be placed in the OFF position, proceed as follows:

1. Push the park button to shift to the P (Park) position.
2. Push the ignition switch. The ignition switch position will change to the ON position.

3. Push the ignition switch again to the OFF position.

The shift position can be shifted from the P (Park) position if the ignition switch is in the ON position and the brake pedal is depressed.

PUSH-BUTTON IGNITION SWITCH POSITIONS

ON (Normal operating position)

The ignition system and the electrical accessory power activate at this position without the engine turned on.

The ON position has a battery saver feature that will place the ignition switch in the OFF position, if the vehicle is not running, after some time under the following conditions:

- all doors are closed.
- vehicle is in P (Park) position.

OFF position

The engine is turned off in this position.

Auto ACC position

With the vehicle in the P (Park) position, the Intelligent Key with you and the ignition placed from ON to OFF, the radio can still be used for a period of time, or until the driver's door is opened. After a period of time, functions such as radio, navigation (if so equipped), and Bluetooth® Hands-Free Phone System may be restarted by turning on the audio system (see the separate NissanConnect® Owner's Manual), or by pushing the UNLOCK button on the Intelligent Key for up to a total of 30 minutes.

EMERGENCY ENGINE SHUT OFF

To shut off the engine in an emergency situation while driving or when the Intelligent Key battery is discharged, perform the following procedure:

- Rapidly push the push-button ignition switch 3 consecutive times in less than 1.5 seconds, or
- Push and hold the push-button ignition switch for more than 2 seconds.

After engine shut-off, open the door to return to the normal condition.

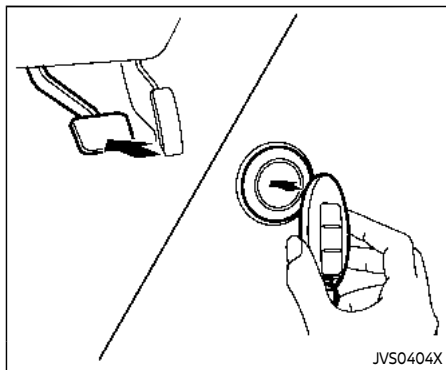

INTELLIGENT KEY BATTERY DISCHARGE

If the battery of the Intelligent Key is discharged, or environmental conditions interfere with the Intelligent Key operation, start the engine according to the following procedure:

1. Push the park button to shift to the P (Park) position.
2. Firmly apply the foot brake.
3. Touch the ignition switch with the Intelligent Key as illustrated. (A chime will sound.)
4. Push the ignition switch while depressing the brake pedal within 10 sec-

onds after the chime sounds. The engine will start.

After step 3 is performed, when the ignition switch is pushed without depressing the brake pedal, the ignition switch position will change to ON.

NOTE:

- **When the ignition switch is pushed to the ON position or the engine is started by the above procedures, the "Key Battery Low" warning appears (on the vehicle information display) even if the Intelligent Key is inside the vehicle. This is not a malfunction. To turn off the warning, touch the ignition switch with the Intelligent Key again.**
- **If the "Key Battery Low" warning appears, replace the battery as soon as possible. (See "Intelligent Key battery replacement" (P.8-24).)**

BEFORE STARTING THE ENGINE

- Make sure the area around the vehicle is clear.
- Check fluid levels such as engine oil, coolant, brake fluid, and window washer fluid as frequently as possible, or at least whenever you refuel.
- Check that all windows and lights are clean.
- Visually inspect tires for their appearance and condition. Also check tires for proper inflation.
- Lock all doors.
- Position seat and adjust head restraints/headrests.
- Adjust inside and outside mirrors.
- Fasten seat belts and ask all passengers to do likewise.
- Check the operation of warning lights when the ignition switch is placed in the ON position. (See "Warning lights, indicator lights and audible reminders" (P.2-13).)

STARTING THE ENGINE

1. Apply the parking brake.
2. Confirm that the vehicle is in the P (Park) position.

The Intelligent Key must be carried when operating the ignition switch.

3. Push the ignition switch to the ON position. Depress the brake pedal and push the ignition switch to start the engine.

To start the engine immediately, push and release the ignition switch while depressing the brake pedal with the ignition switch in any position.

- If the engine is very hard to start in extremely cold weather or when restarting, depress the accelerator pedal a little (approximately 1/3 to the floor) and while holding, crank the engine. Release the accelerator pedal when the engine starts.
- If the engine is very hard to start because it is flooded, depress the accelerator pedal all the way to the floor and hold it. Push the ignition switch to the ON position to start cranking the engine. After 5 or 6 seconds, stop cranking by pushing the ignition switch to OFF. After cranking the engine, release the accelerator pedal. Crank the engine **with your foot off the accelerator pedal** by depressing the brake

pedal and pushing the push-button ignition switch to start the engine. If the engine starts, but fails to run, repeat the above procedure.



CAUTION

Do not operate the starter for more than 15 seconds at a time. If the engine does not start, push the ignition switch to OFF and wait 10 seconds before cranking again, otherwise the starter could be damaged.

4. Warm-up

Allow the engine to idle for at least 30 seconds after starting. Do not race the engine while warming it up. Drive at moderate speed for a short distance first, especially in cold weather. In cold weather, keep the engine running for a minimum of 2 - 3 minutes before shutting it off. Starting and stopping the engine over a short period of time may make the vehicle more difficult to start.

When the engine is racing with no load and cold, the engine speed is limited to about 3,000 rpm.

5. To stop the engine, push the park button to shift to the P (Park) position, and push the ignition switch to the OFF position.

NOTE:

Care should be taken to avoid situations that can lead to potential battery discharge and potential no-start conditions such as:

1. Installation or extended use of electronic accessories that consume battery power when the engine is not running (Phone chargers, GPS, DVD players, etc.)
2. Vehicle is not driven regularly and/or only driven short distances.

In these cases, the battery may need to be charged to maintain battery health.

REMOTE ENGINE START (if so equipped)

Vehicles started with the remote engine start function require the ignition switch to be placed in the ON position before the shift position can be shifted from the P (Park) position. To place the ignition switch in the ON position, perform the following steps:

1. Make sure that the Intelligent Key is carried with you.

DRIVING THE VEHICLE

2. Depress the brake pedal.
3. Push the ignition switch once to the ON position.

For additional information about the remote engine start function, see "Remote engine start" (P.3-19).

CONTINUOUSLY VARIABLE TRANSMISSION (CVT)

The CVT in your vehicle is electronically controlled to produce maximum power and smooth operation.

The recommended operating procedures for this transmission are shown on the following pages. Follow these procedures for maximum vehicle performance and driving enjoyment.

Engine power may be automatically reduced to protect the CVT if the engine speed increases quickly when driving on slippery roads or while being tested on some dynamometers.



WARNING

- Do not depress the accelerator pedal while shifting from P (Park) or N (Neutral) to R (Reverse), D (Drive), or M (Manual shift mode). Always depress the brake pedal until shifting is completed. Failure to do so could cause you to lose control and have an accident.
- Cold engine idle speed is high, so use caution when shifting into a forward or reverse gear before the engine has warmed up.

- Do not downshift abruptly on slippery roads. This may cause a loss of control.
- Never shift to either the P (Park) or R (Reverse) position while the vehicle is moving forward and P (Park) or D (Drive) position while the vehicle is reversing. This could cause an accident or damage the transmission.
- Except in an emergency, do not shift to the N (Neutral) position while driving. Coasting with the transmission in the N (Neutral) position may cause serious damage to the transmission.



CAUTION

- To avoid possible damage to your vehicle, when stopping the vehicle on an uphill grade, do not hold the vehicle by depressing the accelerator pedal. The foot brake should be used for this purpose.
- Do not hang items on the shift lever. This may cause an accident due to a sudden start.

Starting the vehicle

1. After starting the engine, fully depress the foot brake pedal before attempting to place the shift position out of the P (Park) position. **This CVT is designed so that the foot brake pedal must be depressed before shifting from P (Park) to any driving position while the ignition switch is in the ON position. The shift position cannot be placed out of the P (Park) position and into any of the other positions if the ignition switch is placed in the OFF position.**
2. Keep the foot brake pedal depressed and move the shift lever into a driving position.
3. Release the parking brake, the foot brake pedal, and then gradually start the vehicle in motion.

CAUTION

- **DEPRESS THE FOOT BRAKE PEDAL** - Shifting the shift lever to D (Drive), R (Reverse) or M (Manual shift mode) without depressing the foot brake pedal causes the vehicle to move slowly when the engine is running. Make sure the foot brake pedal is depressed

fully and the vehicle is stopped before shifting the shift lever.

- **MAKE SURE OF THE SHIFT LEVER POSITION** - Make sure the shift position on the vehicle information display. D (Drive) and M (Manual shift mode) are used to move forward and R (Reverse) to back up.
- **WARM UP THE ENGINE** - Due to the higher idle speeds when the engine is cold, extra caution must be exercised when shifting the shift lever into the driving position immediately after starting the engine.

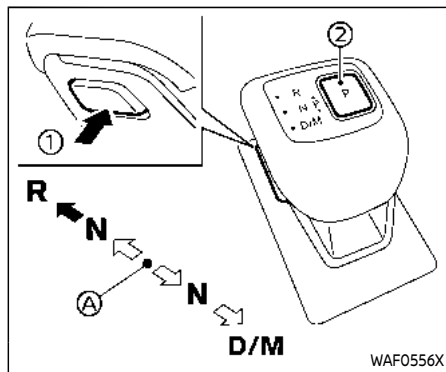

Ⓐ Home position (central position)

Shifting

To move the shift lever,

- ➡: Push the button ① to shift.
- ⇨: Shift without pushing the button ①.

Push the park button ② to shift to the P (Park) position.

After starting the engine, fully depress the brake pedal, push the shift lever button ① and move the shift lever from the P (Park) position ② to any of the desired shift positions.

Confirm that the vehicle is in the desired shift position by checking the shift indi-

cator located on the shift lever or on the vehicle information display.



WARNING

Apply the electronic parking brake if the shift lever is in any position while the engine is not running. Failure to do so could cause the vehicle to move unexpectedly or roll away and result in serious personal injury or property damage.



CAUTION

- Use the P (Park), R (Reverse) or D (Drive) position only when the vehicle is completely stopped.
- When switching to the desired shift position by operating the shift lever, check that the shift lever returns to the central position by releasing your hand from the lever. Holding the shift lever in a mid-way position may also damage the shift control system.
- Do not operate the shift lever while the accelerator pedal is depressed. This may cause a

sudden start which could result in an accident.

- The following operations are not allowed because excessive force would be applied to the transmission and this may result in damage to the vehicle:
 - Moving the shift lever to the R (Reverse) position when driving forward
 - Moving the shift lever to the D (Drive) position when reversing

If these operations are attempted, a chime sounds and the vehicle shifts to the N (Neutral) position.

P (Park):



CAUTION

- To prevent transmission damage, use the P (Park) position only when the vehicle is completely stopped.
- Do not slide the shift lever while pushing the park button. This may damage the shift control

system.

Use this position when the vehicle is parked or starting the engine. Always make sure that the vehicle is completely stopped before pushing the park button to engage the P (Park) position. For maximum safety, the brake pedal must be depressed before engaging the P (Park) position. Use this position together with the electronic parking brake. When parking on a hill, first depress the brake pedal, apply the electronic parking brake and then engage the P (Park) position. The parking lock should not be used as a brake when parking. In order to secure the vehicle, always apply the electronic parking brake in addition to the parking lock.

In the event of a malfunction of the vehicle's electronics, the transmission may lock in the P (Park) position. Have the vehicle's electronics checked immediately. It is recommended that you visit a NISSAN dealer for this service.

The P (Park) position is automatically engaged if:

- You switch off the ignition switch
- You unfasten the driver's seat belt and open the driver side door when the vehicle is stationary or driving at very

low speed and the transmission is in the D (Drive) position, the R (Reverse) position or the N position unless the Neutral hold mode is engaged.



CAUTION

To avoid CVT malfunction, it is recommended that you manually place the shift position in the P (Park) position under the above conditions.

R (Reverse):



CAUTION

To prevent transmission damage, use the R (Reverse) position only when the vehicle is completely stopped.

Use the R (Reverse) position to back up. Make sure the vehicle is completely stopped before selecting the R (Reverse) position. **The brake pedal must be depressed and the shift lever button pushed to move the shift lever from the home position to R (Reverse). If the vehicle is placed in the R (Reverse) position while the vehicle is moving**

forward, the chime will sound and the vehicle will switch into the N (Neutral) position.

N (Neutral):

Neither the forward nor reverse gear is engaged. The engine can be started in this position. You may shift to the N (Neutral) position and restart a stalled engine while the vehicle is moving.

You can select this position by holding the shift lever at this position for approximately 0.5 seconds.

D (Drive):

Use this position for all normal forward driving. The CVT changes gears automatically. All forward gears are available. **If the vehicle is placed in the D (Drive) position while the vehicle is reversing, the chime will sound and the vehicle will switch into the N (Neutral) position.**

Neutral hold mode function

This function enables you to turn off the engine with the vehicle in the N (Neutral) position. While this function is activated, the vehicle can be moved by pushing with hand (when car washing) even if the ignition switch is in the OFF position. When using this function, release the electronic parking brake.



WARNING

- Use this function on a level surface only. Failure to do so may cause the vehicle to move accidentally and could result in a collision or serious personal injury.
- Do not use this function for a purpose other than car washing.
- When the ignition switch is placed in the ON position after activating this function, depress the brake pedal to stop the vehicle because the shift lever is in the N (Neutral) position.
- If this function is not activated regardless of proper operation, transmission may malfunction. It is recommended that you visit a NISSAN dealer for this service.

To activate the Neutral hold mode, perform the following operations.

1. Push the ignition switch to start the engine.
2. Release the electronic parking brake.
3. Depress and hold the brake pedal.

4. Push the P position switch.
5. Slide the shift lever to the N (Neutral) position, and hold it for approximately 0.5 seconds until "N" appears in the vehicle information display.
6. Slide the shift lever to the N (Neutral) position again, and hold it for approximately 0.5 seconds, until a message "Neutral Hold Mode has been activated" appears in the vehicle information display. (See "66. Neutral Hold Mode activated indicator" (P.2-44).)
7. Place the ignition switch in the OFF position. The engine will turn off with holding the N (Neutral) position.

To exit the Neutral hold mode, place the vehicle in other than N (Neutral) position.

NOTE:

- **It is necessary to perform the steps 4 through 6 within approximately 5 seconds to prevent incorrect operation.**
- **When the ignition switch is placed in the OFF position while the shift lever is in the N (Neutral) position, a message will appear in the vehicle information display. (See "65. Neutral Hold Mode guidance indicator" (P.2-44).)**
- **If the Neutral hold mode is unavailable, a message will appear in the**

vehicle information display. (See "67. Neutral Hold Mode was not activated indicator" (P.2-44).) To activate the Neutral hold mode, wait for a while without shifting operation and then perform the operations again.

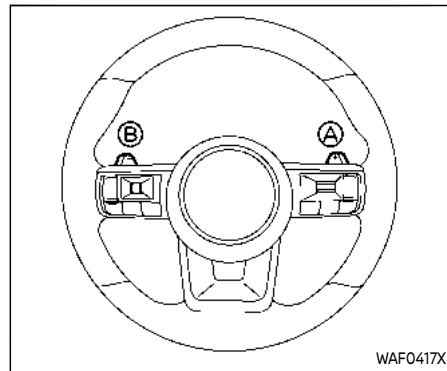

Paddle shifter

Manual shift mode

When the shift lever is moved to the D (Drive) position again with the vehicle in the D (Drive) position while driving, the transmission enters the manual shift mode. Shift range can be selected manually using the paddle shifters on the steering wheel.

When shifting up, pull the right-side paddle shifter (+) **A**. The transmission shifts to the higher range.

When shifting down, pull the left-side paddle shifter (-) **B**. The transmission shifts to the lower range.

When canceling the manual shift mode,

move the shift lever to the D (Drive) position again. The transmission returns to the normal driving mode.

When you pull the paddle shifter while in the D (Drive) position, the transmission will shift to the upper or lower range temporarily. The transmission will automatically return to the D (Drive) position after a short period of time. If you want to return to the D (Drive) position manually, pull and hold the paddle shifter for about 1.5 seconds.

In the manual shift mode, the shift range is displayed in the vehicle information display.

Shift ranges up or down one by one as follows:

1^M → 2^M → 3^M → 4^M → 5^M → 6^M → 7^M → 8^M
← ← ← ← ← ← ← ←

8^M (8th):

Use this position for all normal forward driving at highway speeds.

7^M (7th), 6^M (6th) and 5^M (5th):

Use these positions when driving up long slopes, or for engine braking when driving down long slopes.

4^M (4th), 3^M (3rd) and 2^M (2nd):

Use these positions for hill climbing or engine braking on downhill grades.

1^M (1st):

Use this position when climbing steep hills slowly or driving slowly through deep snow, or for maximum engine braking on steep downhill grades.

- Remember not to drive at high speeds for extended periods of time in lower than 8th gear. This reduces fuel economy.
- Pulling the same paddle shifter twice will shift the ranges in succession. However, if this motion is rapidly done, the second shifting may not be completed properly.
- **In the manual shift mode, the transmission may not shift to the selected gear. This helps maintain driving performance and reduces the chance of vehicle damage or loss of control.**
- **When this situation occurs, the Continuously Variable Transmission (CVT) position indicator will blink and the chime will sound.**
- **In the manual shift mode, the transmission may shift up automatically to a higher range than selected if the engine speed is too high. When the vehicle speed decreases, the transmission automatically shifts down and shifts to 1st gear before the vehicle comes to a stop.**

- CVT operation is limited to automatic drive mode when CVT fluid temperature is extremely low even if manual shift mode is selected. This is not a malfunction. When CVT fluid warms up, manual shift mode can be selected.
- When the CVT fluid temperature is high, the shift range may upshift in lower rpm than usual. This is not a malfunction.

Accelerator downshift - in D (Drive) position -

For passing or climbing hills, depress the accelerator pedal to the floor. This shifts the transmission down into a lower gear, depending on the vehicle speed.

High fluid temperature protection mode

This transmission has a high fluid temperature protection mode. If the fluid temperature becomes too high, (for example, when climbing steep grades in high temperatures with heavy loads, such as when towing a trailer), engine power and, under some conditions, vehicle speed will be decreased automatically to reduce the chance of transmission damage. Vehicle speed can be controlled with the accelerator pedal, but the engine

and vehicle speed may be limited.

Fail-safe

When the fail-safe operation occurs, the Continuously Variable Transmission will not be shifted into the selected driving position.

If the vehicle is driven under extreme conditions, such as excessive wheel spinning and subsequent hard braking, the fail-safe system may be activated. The Malfunction Indicator Light (MIL) may come on to indicate the fail-safe mode is activated. For additional information, refer to "Malfunction Indicator Light (MIL)" (P.2-19). This will occur even if all electrical circuits are functioning properly. In this case, place the ignition switch in the OFF position and wait for 10 seconds. Then place the ignition switch back in the ON position. The vehicle should return to its normal operating condition. (The MIL may be illuminated even when the vehicle has returned to its normal operating condition.) If it does not return to its normal operating condition, have the transmission checked and repaired, if necessary, by a NISSAN dealer.



WARNING

When the high fluid temperature protection mode or fail-safe operation occurs, vehicle speed may be gradually reduced. The reduced speed may be lower than other traffic, which could increase the chance of a collision. Be especially careful when driving. If necessary, pull to the side of the road at a safe place and allow the transmission to return to normal operation, or have it repaired if necessary.



WARNING

- **Never drive the vehicle with the parking brake applied. The brake will overheat and fail to operate and will lead to an accident.**
- **Never release the parking brake from outside the vehicle. If the vehicle moves, it will be impossible to push the foot brake pedal and will lead to an accident.**
- **Never use the shift lever in place of the parking brake. When parking, be sure the parking brake is fully applied.**
- **To help avoid risk of injury or death through unintended operation of the vehicle and/or its systems, do not leave children, people who require the assistance of others or pets unattended in your vehicle. Additionally, the temperature inside a closed vehicle on a warm day can quickly become high enough to cause a significant risk of injury or death to people and pets.**

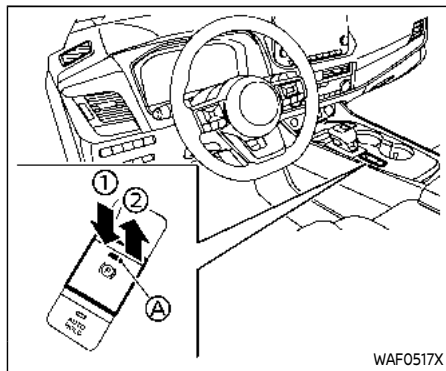

WAF0517X

- ① Release
- ② Apply
- Ⓐ Indicator light

The electronic parking brake can be applied or released automatically or by operating the parking brake switch.

AUTOMATIC OPERATION

The electronic parking brake will apply automatically under any of the following conditions while the brake force is maintained by the automatic brake hold function:

- When the ignition switch is placed in the OFF position.

- When the shift position is placed in the P (Park) position.
- When the driver's door is opened.
- When the driver's seat belt is unfastened.

The electronic parking brake is automatically released as soon as the vehicle starts while the accelerator pedal is depressed under the following conditions.

- While the engine is running.
- When the shift position is in the D (Drive) or R (Reverse) position.
- When the driver's door is closed.

The electronic parking brake is automatically released within 5 seconds after the shift position is placed in the D (Drive) or R (Reverse) position even if the driver's door is opened. Be sure to close the door before starting the vehicle.

WARNING

- **When the automatic brake hold function is activated, the electronic parking brake will not be automatically applied when the engine is stopped without using the ignition switch (for example, by engine stalling).**

Without the vehicle stationary, the electronic parking brake will not be automatically applied even if the engine is turned off with the ignition switch.

- **Before leaving the vehicle, place the shift position in the P (Park) position and check that the electronic parking brake warning light is illuminated to confirm that the electronic parking brake is applied. The electronic parking brake warning light will remain on for a period of time after the driver's door is locked.**

CAUTION

When parking in an area where the outside temperature is below 32°F (0°C), the electronic parking brake, if applied, may freeze in place and may be difficult to release.

For safe parking, it is recommended that you place the shift position in the P (Park) position and securely block the wheels.

NOTE:

- To keep the electronic parking brake released after the engine is turned off, place the ignition switch in the OFF position, depress the brake pedal and push down the parking brake switch before opening the driver's door.
- If a malfunction occurs in the electronic parking brake system (for example, due to battery discharge), it is recommended to contact a NISSAN dealer.
- Under the following conditions, the electronic parking brake will automatically be applied and the brake force of the automatic brake hold will be released.
 - The braking force is applied by the automatic brake hold function for 3 minutes or longer.
 - The vehicle is in the P (Park) position.
 - The electronic parking brake is applied manually.
 - The driver's seat belt is unfastened.
 - The driver's door is opened.
 - The ignition switch is placed in the OFF position.

- A malfunction occurs in the automatic brake hold function.
- Make sure that the electronic parking brake system warning light is OFF before starting the vehicle.

MANUAL OPERATION

To apply: When the vehicle is stopped, pull the parking brake switch ② up. (The electronic parking brake will apply even if the ignition switch is placed in the OFF position.) The indicator light ④ on the switch and the electronic parking brake warning light PARK or ⑤ (red) will illuminate.

To release: With the ignition switch in the ON position, depress the brake pedal and push the parking brake switch down ①. The indicator light ④ and the electronic parking brake warning light (red) will turn off.

Before driving, check that the electronic parking brake warning light (red) turns off. For additional information, see "Warning lights, indicator lights and audible reminders" (P.2-13).

NOTE:

- While the electronic parking brake is applied or released, an operating sound is heard from the lower side of the rear seat. This is normal and does not indicate a malfunction.

- When the electronic parking brake is frequently applied and released in a short period of time, the electronic parking brake system warning light may blink and the electronic parking brake may not operate in order to prevent the electronic parking brake system from overheating. If this occurs, operate the parking brake switch again after waiting approximately 1 minute.
- If the electronic parking brake must be applied while driving in an emergency, pull up and hold the parking brake switch. When you release the parking brake switch, the electronic parking brake will be released.
- While pulling up the parking brake switch during driving, the electronic parking brake is applied and a chime sounds. The electronic parking brake warning light (red) and the indicator light on the parking brake switch illuminate. This does not indicate a malfunction. The electronic parking brake warning light (red) and the indicator light on the parking brake switch will turn off when the electronic parking brake is released.
- When pulling the parking brake switch up with the ignition switch in the OFF position, the indicator

light on the parking brake switch will continue to illuminate for a short period of time.

When towing a trailer

Depending on the weight of the vehicle and trailer and the steepness of the slope, there may be a tendency for the vehicle to move backwards when starting from a standstill. When this occurs, you can use the parking brake switch in the same way as a conventional lever type parking brake.

Before starting on sloping roads when towing a trailer, be sure to read the following to prevent the vehicle from moving backward unintentionally.

- Release the parking brake switch as soon as the engine is delivering enough torque to the wheels.

AUTOMATIC BRAKE HOLD

The automatic brake hold function maintains the braking force without the driver having to depress the brake pedal when the vehicle is stopped at a traffic light or intersection. As soon as the driver depresses the accelerator pedal again, the automatic brake hold function is deactivated and the braking force is released. The operating status of the automatic brake hold can be displayed. (See "Warning lights, indicator lights and audible reminders" (P.2-13).)



WARNING

- **The automatic brake hold function is not designed to hold the vehicle on a steep hill or slippery road. Never use the automatic brake hold function when the vehicle is stopped on a steep hill or slippery road. Failure to do so may cause the vehicle to move.**
- **Warnings may appear to request that the driver retake control by depressing the brake pedal.**
- **When the automatic brake hold function is activated but fails to maintain the vehicle at a standstill, depress the brake pedal to stop the vehicle. If the vehicle unexpectedly moves due to out-**

side conditions, the chime may sound and warnings may appear.

- **Be sure to deactivate the automatic brake hold function when using a drive-thru car wash or towing your vehicle.**
- **Make sure the vehicle is in the P (Park) position and apply the electronic parking brake when parking your vehicle, riding on or off the vehicle, or loading or unloading luggage. Failure to do so could cause the vehicle to move or roll away unexpectedly and result in serious personal injury or property damage.**
- **If any of the following conditions occur, the automatic brake hold function may not function. Have the system checked promptly. It is recommended that you visit a NISSAN dealer for this service.**
 - A warning message appears.
 - The indicator light on the automatic brake hold switch does not illuminate when the switch is pushed.

Failure to operate the vehicle in accordance with these conditions could cause the vehicle to move or roll away unexpectedly and

result in serious personal injury or property damage.

- The automatic brake hold function will not be activated if the slip indicator light, electronic parking brake warning light, electronic parking brake system warning light, or master warning light illuminates and the Chassis Control System Error warning message appears.
- To maintain the braking force to keep the vehicle to a standstill, a noise may be heard. This is not a malfunction.
- The automatic brake hold function is operated by applying sufficient brake force to hold the vehicle in its place, so there are cases when this hold function is maintained even if the accelerator pedal is depressed. In this situation, it is advised to depress the brake pedal first, then to turn off the automatic brake hold switch. This will cancel the hold function.

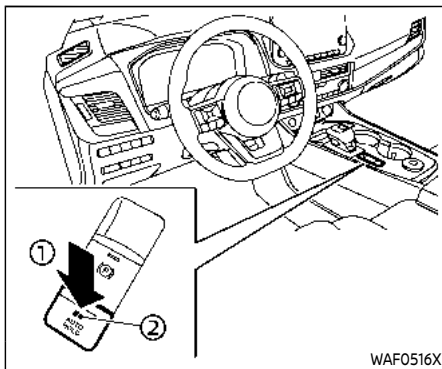

HOW TO ACTIVATE/DEACTIVATE THE AUTOMATIC BRAKE HOLD FUNCTION

How to activate the automatic brake hold function

1. With the ignition switch in the ON position, push the automatic brake hold switch ①. The indicator light on the automatic brake hold switch ② illuminates.
2. When the automatic brake hold function goes into standby, the automatic brake hold indicator light (white) illuminates.

To use the automatic brake hold function,

the following conditions need to be met.

- The driver's seat belt is fastened.
- The electronic parking brake is released.
- The vehicle is not in the P (Park) position.
- The vehicle is not parked on a steep hill.

NOTE:

The automatic brake hold function retains the last state until the driver changes the option even if the ignition switch is turned off.

How to deactivate the automatic brake hold function

While the automatic brake hold function is activated, push the automatic brake hold switch to turn off the automatic brake hold indicator light and deactivate the automatic brake hold function. To deactivate the automatic brake hold function while the brake force has been maintained by the automatic brake hold function, depress the brake pedal and push the automatic brake hold switch.



WARNING

Make sure to firmly depress and hold the brake pedal when turning off the automatic brake hold function while the brake force is applied. When the automatic brake hold function is deactivated, the brake force will be released. This could cause the vehicle to move or roll away unexpectedly.

Failure to prevent the vehicle from rolling may result in serious personal injury or property damage.

HOW TO USE THE AUTOMATIC BRAKE HOLD FUNCTION

For additional information on using the automatic brake hold function, refer to the instructions outlined in this section.

To maintain braking force automatically

With the automatic brake hold function activated and the automatic brake hold indicator light (white) illuminated, depress the braking pedal to stop the vehicle and the indicator light (green) illuminates. The brake force is automatically applied without your foot depressed on the brake

pedal. While the brake force is maintained, the automatic brake hold indicator light (green) illuminates.

The automatic brake hold indicator light (green) will not illuminate if the brake pedal is not pressed with sufficient force to hold the vehicle or is released too quickly when the vehicle is stopped.

Confirm the automatic brake hold indicator light (green) is illuminated before removing your foot from the brake pedal.

To start the vehicle from a standstill

With the vehicle not in the P (Park) or the N (Neutral) position, depress the accelerator pedal while the brake force is maintained. The brake force will automatically be released to restart the vehicle. The automatic brake hold indicator light (white) illuminates and the automatic brake hold returns to standby.

Parking

When the vehicle is in the P (Park) position with the brake force maintained by the automatic brake hold function, the electronic parking brake will automatically be applied and the brake force of the automatic brake hold will be released. The automatic brake hold indicator light turns off. When the electronic parking brake is

applied with the brake force maintained by the automatic brake hold function, the brake force of the automatic brake hold will be released. The automatic brake hold indicator light turns off.

NOTE:

- **Under the following conditions, the electronic parking brake will automatically be applied and the braking force of the automatic brake hold will be released (the automatic brake hold indicator light turns off):**
 - **The braking force is applied by the automatic brake hold function for 3 minutes or longer.**
 - **The vehicle is in the P (Park) position.**
 - **The electronic parking brake is applied manually.**
 - **The driver's seat belt is unfastened.**
 - **The driver's door is opened.**
 - **The ignition switch is placed in the OFF position.**
 - **A malfunction occurs in the automatic brake hold function.**
- **When the vehicle stops, but the brake force is not automatically applied, depress the brake pedal firmly until the automatic brake hold indicator light (green) illuminates.**

DRIVE MODE SELECTOR

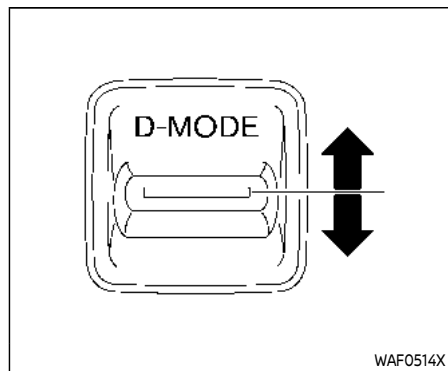

Drive Mode Selector: 2WD models

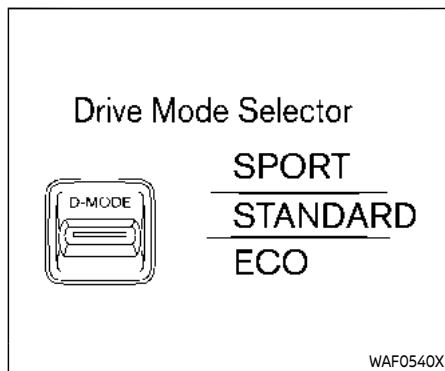

Vehicle information display: 2WD models

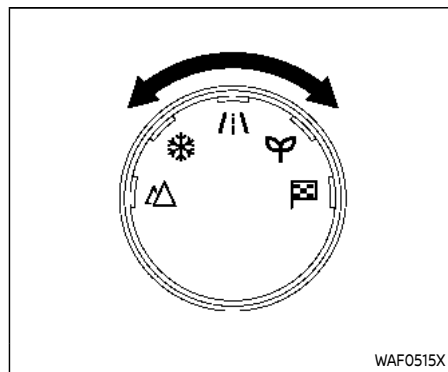

Drive Mode Selector: AWD models

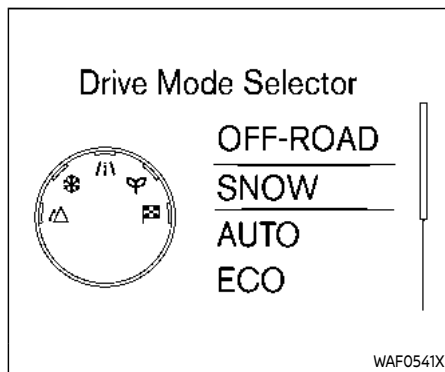

Vehicle information display: AWD models

Multiple driving modes can be selected by using the Drive Mode Selector.

2WD: SPORT, STANDARD and ECO

To change the mode, push the Drive Mode Selector up or down.

AWD: OFF-ROAD, SNOW, AUTO, ECO and SPORT

To change the mode, turn the Drive Mode Selector right or left.

NOTE:

When the Drive Mode Selector selects a mode, the mode may not switch immediately. This is not a malfunction.

The current mode is displayed in the vehicle information display. The mode list will appear in the vehicle information display and you can select the mode.

NOTE:

The mode list will be turned off in approximately 5 seconds after the mode is selected. (The mode list can be turned off by pushing the scroll dial on the steering-wheel mounted controls.)

If the driving mode cannot be switched using the Drive Mode Selector when the ignition switch is in the ON position, have the system checked. It is recommended you visit a NISSAN dealer for this service.



WARNING

Do not stare at the Drive Mode Selector or the display while driving so that full attention may be given to vehicle operation.

OFF-ROAD MODE (AWD models)

Allows for easier driving or starting on a bumpy road surface such as an uneven dirt road or a steep uphill slope or through sand.



CAUTION

Never drive on dry, hard surface roads in the OFF-ROAD mode, as this will overload the powertrain and may cause a serious malfunction. Additionally, this will cause premature tire wear and reduced fuel economy.

When the OFF-ROAD mode is selected, small tight-corner braking phenomenon or small vibration in cornering may occur. This is not a malfunction.

SNOW MODE (AWD models)

This mode makes it easier to start and drive on snowy roads and frozen roads.



CAUTION

Never drive on dry, hard surface roads in the SNOW mode, as this will overload the powertrain and may cause a serious malfunction. Additionally, this will cause premature tire wear and reduced fuel economy.

When the SNOW mode is selected, small vibration in cornering may occur. This is not a malfunction.

STANDARD MODE (2WD models)/ AUTO MODE (AWD models)

This is the standard mode that is most suitable for normal driving.

This mode will be selected first each time the ignition switch is placed in the ON position.

ECO MODE

Assists the driver's ECO-driving. The engine and transmission points are adjusted for improved fuel economy, providing such a driving features as smooth starting or constant cruising.

NOTE:

Selecting the ECO mode will not necessarily improve fuel economy as many driving factors influence its effectiveness.

Operation

Select the ECO mode using the Drive Mode Selector. The ECO indicator illuminates.

When the accelerator pedal is depressed within the range of economy drive, the ECO indicator illuminates in green. When the accelerator pedal is depressed above the range of economy drive, the ECO indicator turns off.

The ECO indicator will not illuminate in the following cases:

- When the shift lever is in the R (Reverse) position.
- When the vehicle speed is below 2 MPH (3.2 km/h) or over 90 MPH (144 km/h).

- When the cruise control (if so equipped) or the Intelligent Cruise Control (ICC) system (if so equipped) is operated.

ECO Mode Customize

The "ECO Mode Customize" is a function that can change the priority from the Cruise Control (if so equipped) or the Intelligent Cruise Control (ICC) function to fuel efficiency improvements. It can be set when the ECO mode is selected. To activate or deactivate this function, see "ECO Mode Setting" (P.2-26).

- Cruise Control

When the setting is ON, the fuel efficiency while cruising will be improved by lowering the acceleration target from normal (setting OFF) mode.

NOTE:

When the vehicle speed is reduced (for example, when the vehicle is driven on an uphill road from a flat road), it will take more time to return to the previously set speed than normal mode.

Tire Pres ECO advice

The "Tire Pres ECO advice" is a function to show an ECO advice message in the vehicle information display when low tire pressure is detected. To activate or deactivate this function, see "ECO Mode Setting" (P.2-26).

When the setting is ON, the ECO Drive Report display shows "Check Tire Pressures for Best Fuel Economy". You can switch the display to the Tire Pressures display by pushing the ◀ ▶ button on the steering wheel.

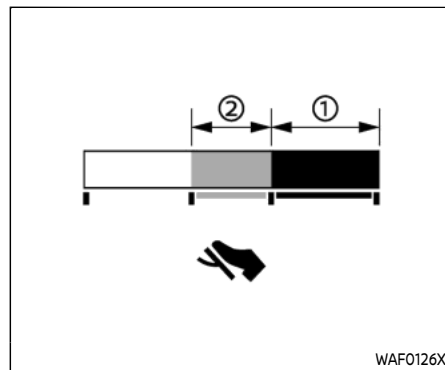

ECO Pedal Guide function

The ECO Pedal Guide display can be selected in the vehicle information display in the ECO mode. (See "5. ECO Pedal Guide" (P.2-48).) Use the ECO Pedal Guide function for improving fuel economy.

When the ECO Pedal Guide bar is in the green range ①, it indicates that the vehicle is being driven within range of the super economy drive.

When the ECO Pedal Guide bar is in the light green range ②, it indicates that the vehicle is being driven within range of the economy drive.

If the ECO Pedal Guide bar is out of the

green range (① and ②), it indicates that the accelerator pedal is depressed over the range of economy drive.

The ECO Pedal Guide bar is not displayed when:

- The vehicle speed is less than approximately 2 MPH (4 km/h).
- The shift lever is in the P (Park), N (Neutral) or R (Reverse) position.

SPORT MODE











- Adjusts the engine and transmission points for a higher response.
- The setting of the steering system is adjusted to moderately increase steering wheel effort for a sporty feel.





NOTE:



In the SPORT mode, fuel economy may be reduced.

DRIVER ASSISTANCE SYSTEMS

Each Driver Assistance system is designed to help the driver in different ways as they drive. The following Driver Assistance systems (if so equipped) are available on this vehicle:

Category	System	Symbol	System description (See the specified page for detailed information.)	Page
Forward Driving Aids	Automatic Emergency Braking (AEB) with Pedestrian Detection		Assists the driver with a warning and/or braking operation when there is a risk of a forward collision with the vehicle ahead in the traveling lane, or with a pedestrian or a cyclist.	5-122
	Intelligent Forward Collision Warning (I-FCW)		Helps alert the driver when there is a sudden braking of a second vehicle traveling in front of the vehicle ahead in the same lane.	5-132
	Intelligent Cruise Control (ICC) (models with ProPILOT Assist)		Intelligent Cruise Control (ICC) <ul style="list-style-type: none"> Helps the driver maintain a selected distance from the vehicle ahead and can reduce the speed to match a slower vehicle ahead. Decelerates the vehicle to a standstill when a vehicle ahead slows to a stop. 	5-98
			Conventional (fixed speed) cruise control mode <ul style="list-style-type: none"> Allows the driver to drive the vehicle at a fixed speed without keeping his/her foot on the accelerator pedal. 	5-119
	Cruise control (models without ProPILOT Assist)		Allows the driver to drive the vehicle at a fixed speed without keeping his/her foot on the accelerator pedal. (For vehicles equipped with the ProPILOT Assist, see "Conventional (fixed speed) cruise control mode" (P.5-119).)	5-83
Side Driving Aids (Lane and Blind Spot)	Lane Departure Warning (LDW)		Warns the driver that the vehicle is about to cross a lane marker with an indicator and a steering wheel vibration.	5-47
	Intelligent Lane Intervention (I-LI)		<ul style="list-style-type: none"> Warns the driver that the vehicle is about to cross a lane marker with an indicator and a steering wheel vibration. Assists the driver to return the vehicle to the center of the traveling lane. 	5-52
	Blind Spot Warning (BSW)		Warns the driver of a vehicle in an adjacent lane when changing lanes with an indicator.	5-58
	Intelligent Blind Spot Intervention (I-BSI)		<ul style="list-style-type: none"> Warns the driver of a vehicle in an adjacent lane when changing lanes. Assists the driver to return the vehicle to the center of the traveling lane. 	5-66
	Steering Assist		Assists the driver to help keep the vehicle within the center of the traveling lane (this system is integrated in the ProPILOT Assist).	5-113

Category	System	Symbol	System description (See the specified page for detailed information.)	Page
Rear Driving Aids	Rear Cross Traffic Alert (RCTA)		Assists the driver when backing out from a parking space by detecting other vehicles approaching from the right or left of the vehicle.	5-77
	Rear Automatic Braking (RAB)		Assists the driver when the vehicle is backing up and approaching stationary objects directly behind the vehicle by providing a warning and automatic braking if needed.	5-143
Parking Aids	RearView Monitor	-	Shows a rear view of the vehicle when the shift lever is placed in the R (Reverse) position.	4-3
	Intelligent Around View® Monitor	-	Assists the driver in parking situations by showing various views of the position of the vehicle in a split screen format.	4-10
	Moving Object Detection (MOD)	-	Informs the driver of moving objects near the vehicle in parking situations.	4-22
	Sonar system	-	Informs the driver with a visual and audible alert of stationary obstacles near the bumpers or the vehicle sides (flanks) (if so equipped).	5-162
	Rear Sonar System (RSS)	-	Informs the driver with a visual and audible alert of stationary obstacles to the rear of the vehicle when the shift lever is in the R (Reverse) position.	5-168
ProPILOT Assist	ProPILOT Assist		Consists of Intelligent Cruise Control (ICC) and Steering Assist.	5-85
	Speed Limit Assist - a feature of ProPILOT Assist with Navi-link		Detects a change of the speed limit, indicates the detected speed limit and can apply it to the vehicle set speed automatically or manually.	5-103
	Speed Adjust by Route - a feature of ProPILOT Assist with Navi-link		Adjusts the vehicle speed depending on curves, junctions and exits, using road information provided by the navigation system.	5-106

Category	System	Symbol	System description (See the specified page for detailed information.)	Page
Other Driving Aids	High beam assist		Switches the headlights to the low beam automatically when an oncoming vehicle or leading vehicle appears in front of your vehicle.	2-61
	Traffic Sign Recognition (TSR)		Provides the driver with information about the most recently detected speed limit.	5-44
	Intelligent Driver Alertness (I-DA)		Helps alert the driver when a lack of attention or driving fatigue is detected.	5-141
	Hill Start Assist	-	Helps prevent the vehicle from rolling backwards in the time it takes the driver to release the brake pedal and apply the accelerator when the vehicle is stopped on a hill.	5-161

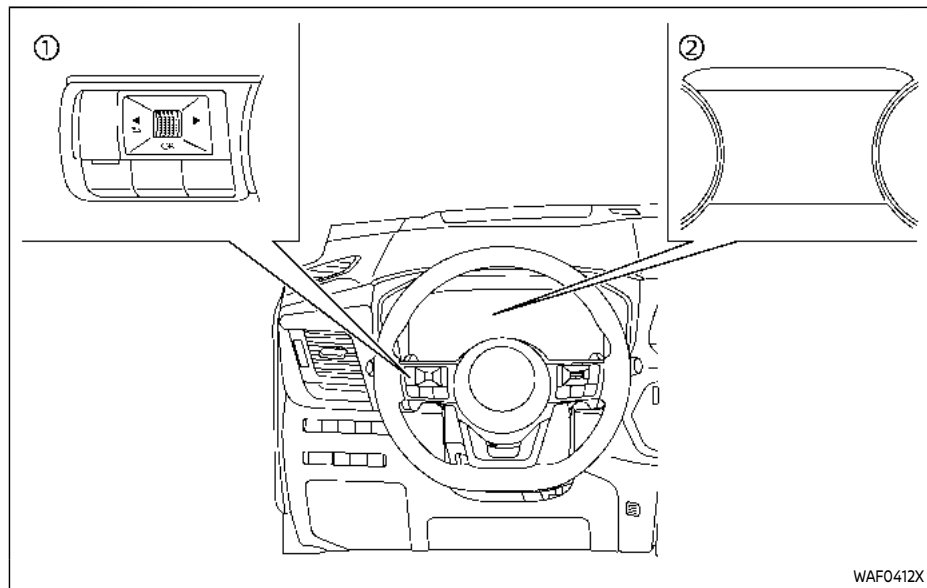

- ① Steering-wheel-mounted controls (left side)
- ② Vehicle information display

HOW TO ENABLE/DISABLE THE SYSTEMS

The following systems (if so equipped) can be enabled or disabled using the settings menu in the vehicle information display. Select each setting item using the scroll dial on the steering-wheel-

mounted controls.

- Automatic Emergency Braking (AEB) with Pedestrian Detection
- Intelligent Forward Collision Warning (I-FCW)
- Lane Departure Warning (LDW)
- Intelligent Lane Intervention (I-LI)*
- Blind Spot Warning (BSW)
- Intelligent Blind Spot Intervention (I-BSI)*
- Steering Assist
- Rear Cross Traffic Alert (RCTA)
- Rear Automatic Braking (RAB)
- Moving Object Detection (MOD)
- Sonar system
- Rear Sonar System (RSS)
- Speed Limit Assist (ProPILOT Assist with Navi-link)
- Speed Adjust by Route (ProPILOT Assist with Navi-link)
- Traffic Sign Recognition (TSR)
- Intelligent Driver Alertness (I-DA)

*: To operate the I-LI and I-BSI systems, you need to push the ProPILOT Assist switch after enabling each system in the settings menu.

Driver Assistance display

The Driver Assistance display appears in the vehicle information display when selected using the scroll dial, or for a short period of time when the ProPILOT Assist switch (if so equipped) is pushed.

The status of the following systems can be shown in each zone of the display.

Zone	Driving Aid
Forward	Automatic Emergency Braking (AEB) with Pedestrian Detection
	Intelligent Forward Collision Warning (I-FCW)
Lane	Lane Departure Warning (LDW)
	Intelligent Lane Intervention (I-LI) (if so equipped)
Blind Spot	Blind Spot Warning (BSW)
	Intelligent Blind Spot Intervention (I-BSI) (if so equipped)

- When any of the “Warning” systems are enabled, the “🔊” mark is shown in each zone.
- When any of the “Intervention” systems are enabled, the “🛑” mark is shown in each zone.
- When no system is enabled, “OFF” is shown in each zone.

The display changes as the following examples:

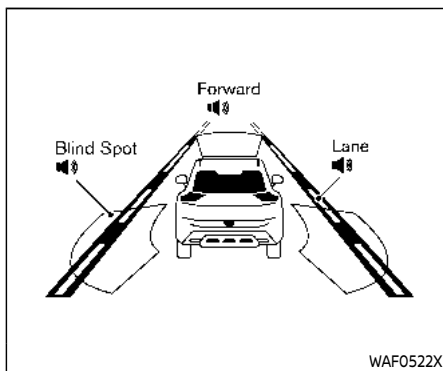

All: outline

Zone	Driving Aid	Status
Forward	Automatic Emergency Braking (AEB) with Pedestrian Detection	Enabled (outline)
	Intelligent Forward Collision Warning (I-FCW)	
Lane	Lane Departure Warning (LDW)	Enabled (outline)
	Intelligent Lane Intervention (I-LI)	Disabled
Blind Spot	Blind Spot Warning (BSW)	Enabled (outline)
	Intelligent Blind Spot Intervention (I-BSI)	Disabled

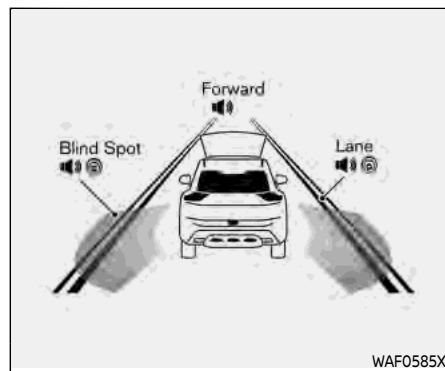





Forward: outline, Other: shaded

Zone	Driving Aid	Status
Forward	Automatic Emergency Braking (AEB) with Pedestrian Detection	Enabled (outline)
	Intelligent Forward Collision Warning (I-FCW)	
Lane	Lane Departure Warning (LDW)	Enabled
	Intelligent Lane Intervention (I-LI)	Enabled (shaded)
Blind Spot	Blind Spot Warning (BSW)	Enabled
	Intelligent Blind Spot Intervention (I-BSI)	Enabled (shaded)

COMMON TROUBLESHOOTING GUIDE

Some of the Driver Assistance systems use the common parts (camera, radar, etc.) to function. When a pop-up warning message appears in the vehicle information display, or the warning light flashes/illuminates, check the system condition. For details, see “System temporarily unavailable” and “System malfunction” sections in this Owner’s Manual for each applicable system.

For camera and radar temporary blockage

Warning message/ Warning light	Symptom	Possible cause	System affected	Action to take
“Unavailable High Cabin Temperature”	High camera temperature	Direct sunlight/High cabin temperature	TSR, LDW, I-LI and I- BSI and Steering Assist	When the interior temperature is reduced, the system resumes automatically. (Push the ProPILOT Assist switch to turn back on the I-LI and I-BSI systems.)
 Flashing			AEB with Pedes- trian Detection and I-FCW	
“Not Available Front Camera Obstructed” or  Flashing	Poor camera visibility	Direct sunlight	Steering Assist and AEB with Pedes- trian Detection	When the condition no longer exists, the system resumes automatically.
	Camera obstruction	Windshield glass misted, frozen or covered with dirt		Clean the windshield glass of the camera area. Use the wipers and the defroster to help clear the windshield glass.
“Forward Driving Aids temporarily disabled Front Sensor blocked See Owner’s Manual” and  Flashing	Front radar obstruction	Inclement weather (rain, fog, snow, etc.)	ICC, AEB with Pe- destrian Detection and I-FCW	When the condition no longer exists, the system resumes automatically. (Push the ProPILOT Assist switch to turn back on the ICC system.)
		Sensor covered with dirt or obstructed		Clean the front radar sensor area on the front of the vehicle.
		Roads with limited road structures or buildings		When the condition no longer exists, the system resumes automatically. (Push the ProPILOT Assist switch to turn back on the ICC system.)
 Flashing	Front radar interruption	Interference from another radar source	ICC, AEB with Pe- destrian Detection and I-FCW	When the condition no longer exists, the system resumes automatically. (Push the ProPILOT Assist switch to turn back on the ICC system.)

Warning message/ Warning light	Symptom	Possible cause	System affected	Action to take
"Unavailable Side Radar Obstruction"	Side radar obstruction	Radar blockage	BSW, I-BSI and RCTA	Clean the side rear radar area on the rear of the vehicle. When the condition no longer exists, the system resumes automatically. (Push the ProPILOT Assist switch to turn back on the I-BSI system.)

For system temporarily unavailable

Warning light/Warning message	Possible cause	System to check	Action to take
 Illuminating	VDC turned off	AEB with Pedestrian Detection	Turn on the VDC.
"Currently not available"	VDC turned off	I-LI, I-BSI and ICC	Turn on the VDC.
	SNOW mode or OFF-ROAD mode selected (AWD models)		Select a mode other than SNOW and OFF- ROAD.

For system malfunction

Warning light/Warning message	Symptom	System to check	Action to take
"Malfunction" and  Illuminating	System malfunction	RCTA, AEB with Pedestrian Detection and I-FCW	Stop the vehicle in a safe location. Turn the engine off and restart the engine. If the warning light/message continues to illuminate, have the system checked. It is recommended that you visit a NISSAN dealer for this service.
"Malfunction See Owner's Manual"		TSR and RAB	
"Not Available System Malfunction"		LDW, I-LI, BSW, I-BSI, ICC and Steering Assist	
"Parking Sensor Error See Owner's Manual"		Sonar system and RSS	
"Driver Attention Alert Malfunction"		I-DA	

Camera, radar and sonar locations

The camera, radar and sonar that are used by each Driver Assistance systems are located on the front and rear of the vehicle. For the maintenance of each component, see "System maintenance" section in this Owner's Manual for each application system.

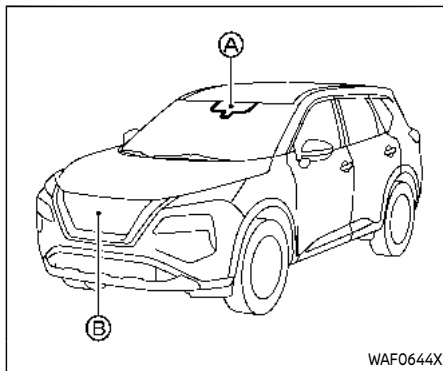

– Intelligent Cruise Control (ICC)

Vehicle front

- Ⓐ Front camera unit
 - Automatic Emergency Braking (AEB) with Pedestrian Detection
 - Lane Departure Warning (LDW)
 - Intelligent Lane Intervention (I-LI)
 - Intelligent Blind Spot Intervention (I-BSI)
 - Steering Assist
 - High beam assist
 - Traffic Sign Recognition (TSR)
- Ⓑ Front radar sensor
 - Automatic Emergency Braking (AEB) with Pedestrian Detection
 - Intelligent Forward Collision Warning (I-FCW)

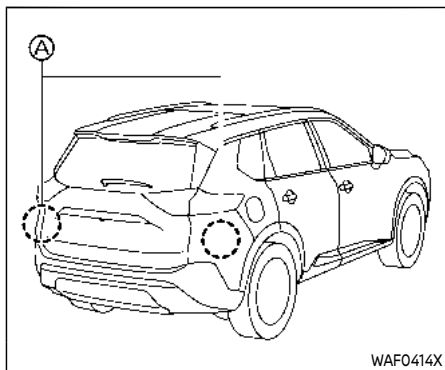

Vehicle rear

- Ⓐ Side radar sensor
 - Blind Spot Warning (BSW)
 - Intelligent Blind Spot Intervention (I-BSI)
 - Rear Cross Traffic Alert (RCTA)

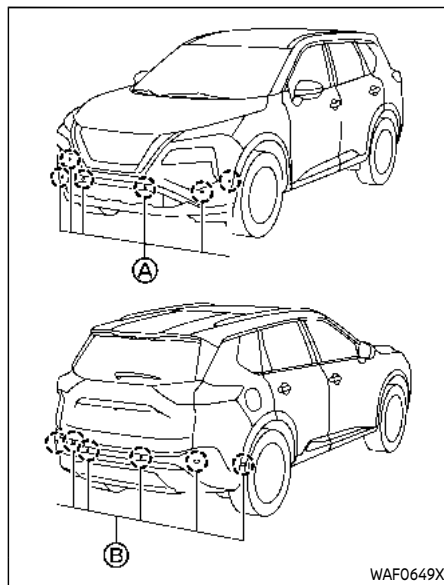

Sonar

- Ⓐ Front and side (if so equipped) sonar sensors
 - Sonar system
- Ⓑ Rear and side (if so equipped) sonar sensors
 - Rear Automatic Braking (RAB)
 - Sonar system

– Rear Sonar System (RSS)

TRAFFIC SIGN RECOGNITION (TSR) (if so equipped)

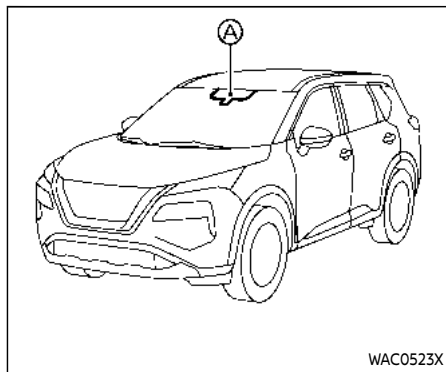

The Traffic Sign Recognition (TSR) system provides the driver with information about the most recently detected speed limit. The system captures the road sign information with the multi-sensing front camera unit (A) located on the windshield in front of the inside mirror and displays the detected signs in the vehicle information display. For vehicles equipped with navigation system, the speed limit displayed is based on a combination of navigation system data and live camera recognition. TSR information is shown in the vehicle information display and in the Head Up Display (HUD) (if so equipped). (See "Head Up Display (HUD)" (P.2-50).)

WARNING

The TSR system is only intended to be a support device to provide the driver with information. It is not a replacement for the driver's attention to traffic conditions or responsibility to drive safely. It cannot prevent accidents due to carelessness. It is the driver's responsibility to stay alert and drive safely at all times.

SYSTEM OPERATION

The TSR system displays the following types of road sign:

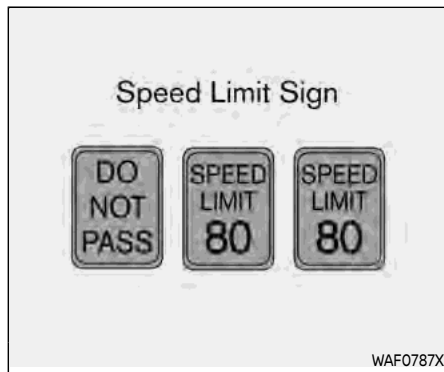

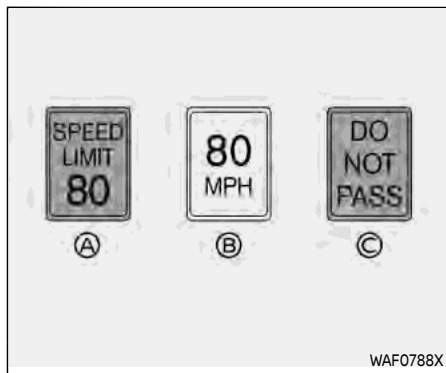

- Ⓐ Latest detected speed limit
- Ⓑ Reduce speed limit caution
- Ⓒ No passing zone

CAUTION

- The TSR system is intended as an aid to careful driving. It is the driver's responsibility to stay alert, drive safely, and observe all road regulations that currently apply, including looking out for road signs.
- The TSR system may not function properly under all conditions. Below are some examples:

- When the road sign is not clearly visible, for example, due to damage or weather conditions.
- When rain, snow or dirt adheres to the windshield in front of the multi-sensing front camera unit.
- When the headlights are not bright due to dirt on the lens or if the aiming is not adjusted properly.
- When strong light enters the camera unit. (For example, the light directly shines on the front of the vehicle at sunrise or sunset.)
- When a sudden change in brightness occurs. (For example, when the vehicle enters or exits a tunnel or under a bridge.)
- In areas not covered by the navigation system.
- If there are deviations in relation to the navigation, for example due to changes in the road routing.

- When overtaking buses or trucks with speed stickers.
- When the data from the navigation system is not up-to-date or is unavailable.
- The TSR system may display a traffic sign, though there is no traffic sign in front of the vehicle. It may display a different speed limit from that for a passenger vehicle. (The maximum speed limit sign may show a higher or lower number than the actual maximum speed, for example, when detecting a speed limit sign for truck, advisory sign, different speed limit sign between daytime and nighttime, or speed limit sign written in different unit near the border, etc.)

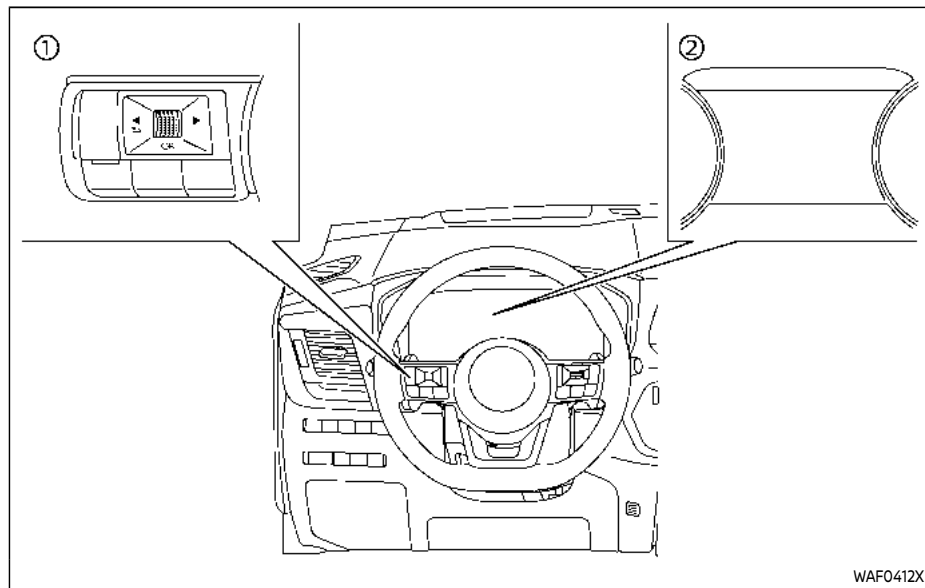

- ① Steering-wheel-mounted controls (left side)
- ② Vehicle information display

HOW TO ENABLE/DISABLE THE TSR SYSTEM

Perform the following steps to enable or disable the TSR system:

1. Push the ◀ ▶ button until "Settings" appears in the vehicle information display and then push the scroll

dial. Use the scroll dial to select "Driver Assistance". Then push the scroll dial.

2. Select "Speed Limit Sign" and push the scroll dial to turn the system on or off.

SYSTEM TEMPORARILY UNAVAILABLE

If the vehicle is parked in direct sunlight under high temperature conditions (over approximately 104°F (40°C) and then started, the TSR system may be deactivated automatically. The "Unavailable High Cabin Temperature" warning message will appear in the vehicle information display.

Action to take:

When the interior temperature is reduced, the TSR system will resume operating automatically.

SYSTEM MALFUNCTION

If the TSR system malfunctions it will be turned off automatically and the TSR "Malfunction See Owner's Manual" warning message will appear in the vehicle information display.

Action to take

If the warning message appears, pull off the road at a safe location and stop the vehicle. Turn the engine off and restart the engine. If the warning message continues to appear, have the system

LANE DEPARTURE WARNING (LDW)

checked by a NISSAN dealer.

SYSTEM MAINTENANCE

The TSR system uses the same multi-sensing front camera unit that is used by the Lane Departure Warning (LDW) system, located in front of the inside mirror. For maintenance of the camera, see "System maintenance" (P.5-51).



WARNING

Failure to follow the warnings and instructions for proper use of the LDW system could result in serious injury or death.

- **This system is only a warning device to inform the driver of a potential unintended lane departure. It will not steer the vehicle or prevent loss of control. It is the driver's responsibility to stay alert, drive safely, keep the vehicle in the traveling lane, and be in control of the vehicle at all times.**

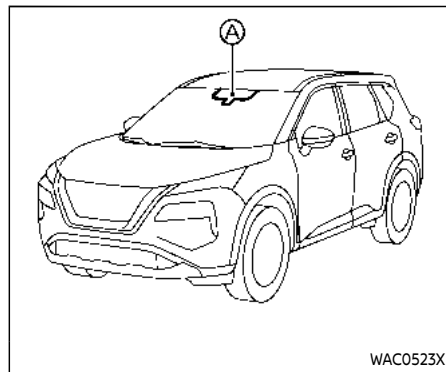

The LDW system will operate when the vehicle is driven at speeds of approximately 37 MPH (60 km/h) and above, and the lane markings are clearly visible on the road.

The LDW system monitors the lane markers on the traveling lane using the camera unit (A) located above the inside mirror.

The LDW system warns the driver that the vehicle is beginning to leave the driving lane with an indicator and a steering wheel vibration. (See "LDW system operation" (P.5-48).)

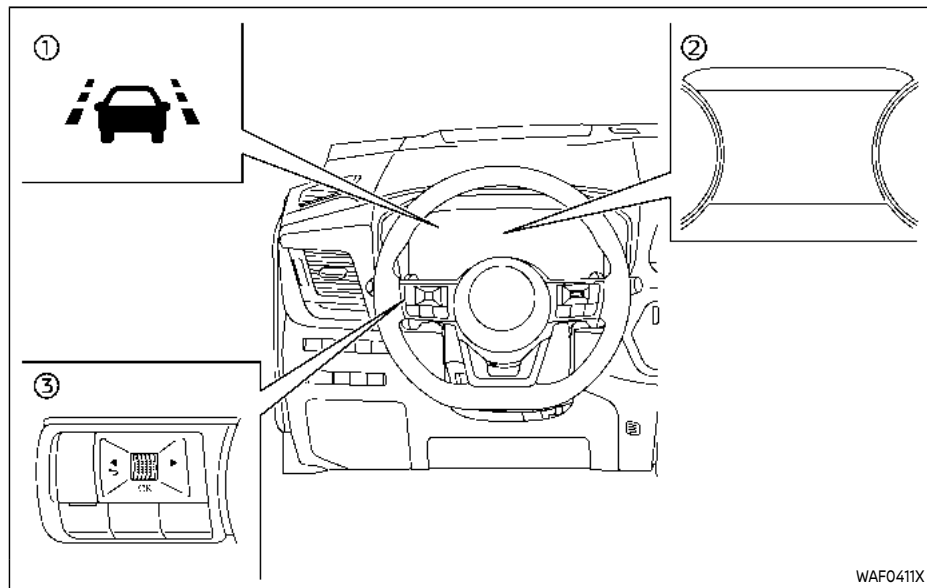

WAFO411X

- ① LDW indicator (on the vehicle information display)
- ② Vehicle information display
- ③ Steering-wheel-mounted controls (left side)

LDW SYSTEM OPERATION

The LDW system provides a lane departure warning function when the vehicle is driven at speeds of approximately 37 MPH (60 km/h) and above and the lane markings are clear. When the vehicle approaches either the left or the right side

of the traveling lane, the steering wheel will vibrate and the LDW indicator on the vehicle information display will blink to alert the driver.

The warning function will stop when the vehicle returns inside of the lane markers.

The strength of the steering wheel vibration can be changed in the settings menu of the vehicle information display. (See "Driver Assistance" (P.2-24).)

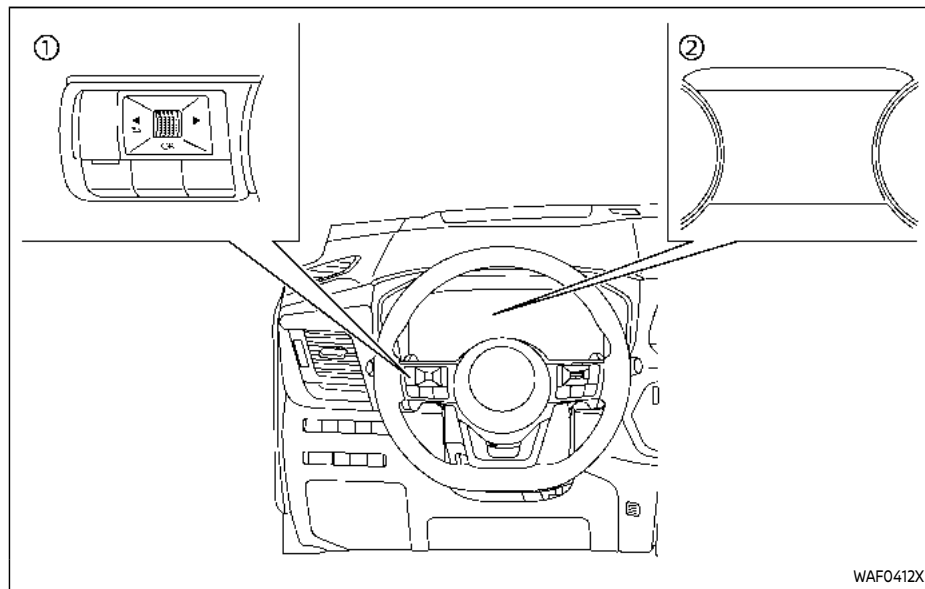

- ① Steering-wheel-mounted controls (left side)
- ② Vehicle information display

HOW TO ENABLE/DISABLE THE LDW SYSTEM

Perform the following steps to enable or disable the LDW system.

1. Push the ◀ ▶ button until "Settings" appears in the vehicle information display and then push the scroll

dial. Use the scroll dial to select "Driver Assistance". Then push the scroll dial.

2. Select "Lane Assist" and push the scroll dial.
3. Select "Warning" and push the scroll dial.

NOTE:

If you disable the LDW system, the system will remain disabled the next time you start the vehicle's engine.

LDW SYSTEM LIMITATIONS



WARNING

Listed below are the system limitations for the LDW system. Failure to follow the warnings and instructions for proper use of the LDW system could result in serious injury or death.

- The system will not operate at speeds below approximately 37 MPH (60 km/h) or if it cannot detect lane markers.
- Do not use the LDW system under the following conditions as it may not function properly:
 - During bad weather (rain, fog, snow, etc.).

- When driving on slippery roads, such as on ice or snow.
- When driving on winding or uneven roads.
- When there is a lane closure due to road repairs.
- When driving in a makeshift or temporary lane.
- When driving on roads where the lane width is too narrow.
- When driving without normal tire conditions (for example, tire wear, low tire pressure, installation of spare tire, tire chains, non-standard wheels).
- When the vehicle is equipped with non-original brake parts or suspension parts.
- When towing a trailer or other vehicle.
- The system may not function properly under the following conditions:
 - On roads where there are multiple parallel lane markers; lane markers that are faded or not painted clearly; yellow painted lane markers; non-standard lane markers; or

- lane markers covered with water, dirt, snow, etc.
- On roads where discontinued lane markers are still detectable.
- On roads where there are sharp curves.
- On roads where there are sharply contrasting objects, such as shadows, snow, water, wheel ruts, seams or lines remaining after road repairs. (The LDW system could detect these items as lane markers.)
- On roads where the traveling lane merges or separates.
- When the vehicle's traveling direction does not align with the lane marker.
- When traveling close to the vehicle in front of you, which obstructs the lane camera unit detection range.
- When rain, snow, dirt or object adheres to the windshield in front of the lane camera unit.
- When the headlights are not bright due to dirt on the lens

or if the aiming is not adjusted properly.

- When strong light enters the lane camera unit. (For example, the light directly shines on the front of the vehicle at sunrise or sunset.)
- When a sudden change in brightness occurs. (For example, when the vehicle enters or exits a tunnel or under a bridge.)
- Steering wheel vibration may not be felt depending on the road surface conditions.

SYSTEM TEMPORARILY UNAVAILABLE

Condition A:

If the vehicle is parked in direct sunlight under high temperature conditions (over approximately 104°F (40°C)) and then started, the LDW system may be deactivated automatically, the LDW indicator will flash and the following message will appear in the vehicle information display.

- "Unavailable High Cabin Temperature"
When the interior temperature is reduced, the LDW system will resume operating automatically and the LDW indicator will

stop flashing.

Condition B:

The warning function of the LDW system is not designed to work under the following conditions:

- When you operate the lane change signal and change traveling lanes in the direction of the signal. (The LDW system will become operable again approximately 2 seconds after the lane change signal is turned off.)
- When the vehicle speed lowers to less than approximately 37 MPH (60 km/h).

Action to take:

After the above conditions have finished and the necessary operating conditions are satisfied, the LDW system will resume.

SYSTEM MALFUNCTION

If the LDW system malfunctions, it will cancel automatically and "Not Available System Malfunction" warning message will appear in the vehicle information display. If the warning message appears, pull off the road to a safe location and stop the vehicle. Place the ignition switch in the OFF position and restart the engine. If the warning message continues to appear, have the system checked. It is recommended that you visit a NISSAN dealer for this service.

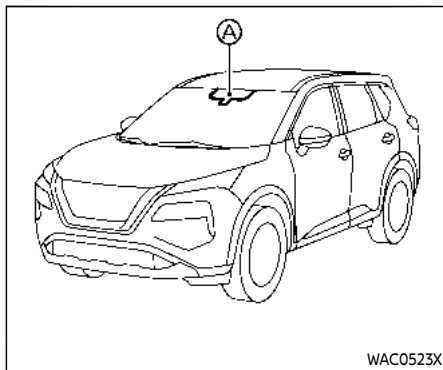

SYSTEM MAINTENANCE

The lane camera unit (A) for the LDW system is located above the inside mirror.

To keep the proper operation of the LDW system and prevent a system malfunction, be sure to observe the following:

- Always keep the windshield clean.
- Do not attach a sticker (including transparent material) or install an accessory near the camera unit.
- Do not place reflective materials, such as white paper or a mirror, on the instrument panel. The reflection of sunlight may adversely affect the camera unit's capability of detecting the lane markers.

- Do not strike or damage the areas around the camera unit. Do not touch the camera lens or remove the screw located on the camera unit. If the camera unit is damaged due to an accident, it is recommended that you visit a NISSAN dealer.

INTELLIGENT LANE INTERVENTION (I-LI) (if so equipped)

WARNING

Failure to follow the warnings and instructions for proper use of the I-LI system could result in serious injury or death.

- The I-LI system will not steer the vehicle or prevent loss of control. It is the driver's responsibility to stay alert, drive safely, keep the vehicle in the traveling lane, and be in control of the vehicle at all times.
- The I-LI system is primarily intended for use on well-developed freeways or highways. It may not detect the lane markers in certain road, weather, or driving conditions.

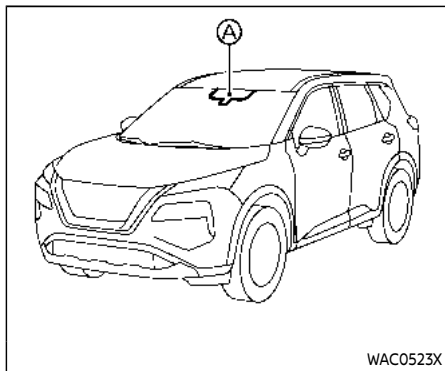

The I-LI system monitors the lane markers on the traveling lane using the camera unit  located above the inside mirror.

The I-LI system must be turned on with the ProPILOT Assist switch on the steering wheel, every time the ignition is placed in the ON position.

The I-LI system will operate when the vehicle is driven at speeds of approximately 37 MPH (60 km/h) and above, and only when the lane markings are clearly visible on the road. The I-LI system warns the driver when the vehicle has left the center of the traveling lane with an indicator and steering wheel vibration. The system helps assist the driver to return the vehicle to the center of the traveling lane by applying the brakes to the left or right wheels individually (for a short period of time).

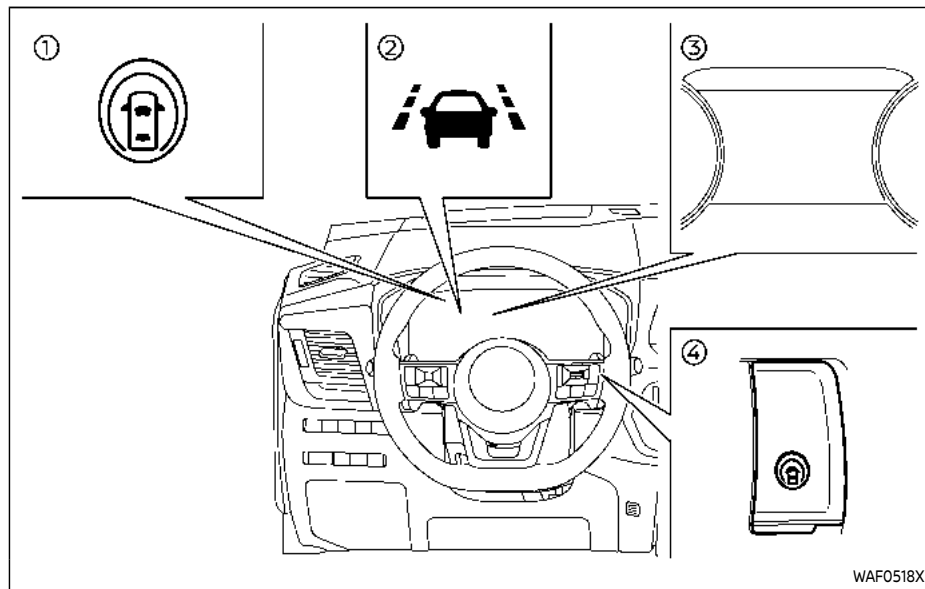

WAF0518X

- ① I-LI ON indicator (on the vehicle information display)
- ② I-LI indicator (on the vehicle information display)
- ③ Vehicle information display
- ④ ProPILOT Assist switch

I-LI SYSTEM OPERATION

The I-LI system operates above approximately 37 MPH (60 km/h) and when the lane markings are clear. When the vehicle approaches either the left or the right side of the traveling lane, steering wheel will vibrate and the I-LI indicator (orange)

on the vehicle information display will blink to alert the driver. Then, the I-LI system will automatically apply the brakes for a short period of time to help assist the driver to return the vehicle to the center of the traveling lane.

To turn on the I-LI system, push the ProPILOT Assist switch on the steering wheel after starting the engine. The I-LI ON indicator on the vehicle information display will illuminate. Push the ProPILOT Assist switch again to turn off the I-LI system. The I-LI ON indicator will turn off.

The strength of the steering wheel vibration can be changed in the settings menu of the vehicle information display. (See "Driver Assistance" (P.2-24).)

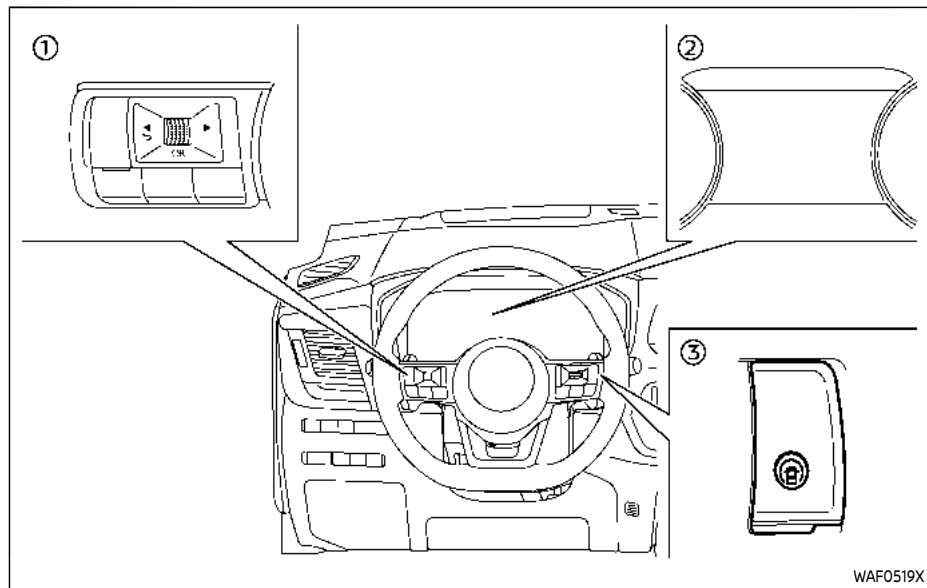

- ① Steering-wheel-mounted control (left side)
- ② Vehicle information display
- ③ ProPILOT Assist switch

HOW TO ENABLE/DISABLE THE I-LI SYSTEM

Perform the following steps to enable or disable the I-LI system.

1. Push the ◀ ▶ button until "Settings" appears in the vehicle information display and then push the scroll dial.

- Use the scroll dial to select "Driver Assistance." Then push the scroll dial.
2. Select "Lane Assist" and push the scroll dial.
3. Select "Intervention" and push the scroll dial.
4. Push the ProPILOT Assist switch to turn the system on or off.

NOTE:

Turning on the ProPILOT Assist system will turn on the I-LI and I-BSI systems at the same time. If the I-LI system is disabled in the settings menu, the I-LI will automatically be turned on when the Steering Assist system is active. (See "ProPILOT Assist" (P.5-85).)

I-LI SYSTEM LIMITATIONS

WARNING

Listed below are the system limitations for the I-LI system. Failure to follow the warnings and instructions for proper use of the I-LI system could result in serious injury or death.

- The I-LI system may activate if you change lanes without first activating your turn signal or, for example, if a construction zone

directs traffic to cross an existing lane marker. If this occurs you may need to apply corrective steering to complete your lane change.

- Because the I-LI may not activate under the road, weather, and lane marker conditions described in this section, it may not activate every time your vehicle begins to leave its lane and you will need to apply corrective steering.
- The I-LI system will not operate at speeds below approximately 37 MPH (60 km/h) or if it cannot detect lane markers.
- When the I-LI system is operating, avoid excessive or sudden steering maneuvers. Otherwise, you could lose control of the vehicle.
- Do not use the I-LI system under the following conditions as it may not function properly:
 - During bad weather (rain, fog, snow, etc.).
 - When driving on slippery roads, such as on ice or snow.
 - When driving on winding or uneven roads.

- When there is a lane closure due to road repairs.
- When driving in a makeshift or temporary lane.
- When driving on roads where the lane width is too narrow.
- When driving without normal tire conditions (for example, tire wear, low tire pressure, installation of spare tire, tire chains, non-standard wheels).
- When the vehicle is equipped with non-original brake parts or suspension parts.
- When towing a trailer or other vehicle.
- On roads where there are multiple parallel lane markers; lane markers that are faded or not painted clearly; yellow painted lane markers; non-standard lane markers; or lane markers covered with water, dirt, snow, etc.
- On roads where discontinued lane markers are still detectable.
- On roads where there are sharp curves.

- On roads where there are sharply contrasting objects, such as shadows, snow, water, wheel ruts, seams or lines remaining after road repairs. (The I-LI system could detect these items as lane markers.)
- On roads where the traveling lane merges or separates.
- When the vehicle's traveling direction does not align with the lane marker.
- When traveling close to the vehicle in front of you, which obstructs the lane camera unit detection range.
- When rain, snow or dirt adheres to the windshield in front of the lane camera unit.
- When the headlights are not bright due to dirt on the lens or if the aiming is not adjusted properly.
- When strong light enters the lane camera unit. (For example, the light directly shines on the front of the vehicle at sunrise or sunset.)

– When a sudden change in brightness occurs. (For example, when the vehicle enters or exits a tunnel or under a bridge.)

- **Steering wheel vibration may not be felt depending on the road surface conditions.**

While the I-LI system is operating, you may hear a sound of brake operation. This is normal and indicates that the I-LI system is operating properly.

SYSTEM TEMPORARILY UNAVAILABLE

Condition A:

The warning and assist functions of the I-LI system are not designed to work under the following conditions:

- When you operate the lane change signal and change the traveling lanes in the direction of the signal. (The I-LI system will be deactivated for approximately 2 seconds after the lane change signal is turned off.)
- When the vehicle speed lowers to less than approximately 37 MPH (60 km/h).

Action to take:

After the above conditions have finished and the necessary operating conditions

are satisfied, the warning and assist functions will resume.

Condition B:

The assist function of the I-LI system is not designed to work under the following conditions (warning is still functional):

- When the brake pedal is depressed.
- When the steering wheel is turned as far as necessary for the vehicle to change lanes.
- When the vehicle is accelerated during the I-LI system operation.
- When the Intelligent Cruise Control (ICC) approach warning occurs (if so equipped).
- When the hazard warning flashers are operated.
- When driving on a curve at high speed.

Action to take:

After the above conditions have finished and the necessary operating conditions are satisfied, the I-LI system application of the brakes will resume.

Condition C:

If the following message appears in the vehicle information display, a chime will sound and the I-LI system will be turned off automatically.

- "Currently not available":

- When the Vehicle Dynamic Control (VDC) system is turned off.
- When the SNOW mode and the OFF-ROAD mode is selected (AWD models).

Action to take:

When the above conditions no longer exist, turn off the I-LI system. Push the ProPILOT Assist switch again to turn the I-LI system back on.

Temporary disabled status at high temperature:

If the vehicle is parked in direct sunlight under high temperature conditions (over approximately 104°F (40°C)) and then the I-LI system is turned on, the I-LI system may be deactivated automatically and the following message will appear on the vehicle information display:

- "Unavailable High Cabin Temperature"
When the interior temperature is reduced, the system will resume operating automatically.

SYSTEM MALFUNCTION

If the I-LI system malfunctions, it will cancel automatically. The I-LI indicator (orange) will illuminate and the "Not Available System Malfunction" warning message will appear in the vehicle information display.

If the I-LI indicator (orange) illuminates, pull off the road to a safe location. Turn the engine off and restart the engine. If the I-LI indicator (orange) continues to illuminate, have the I-LI system checked. It is recommended that you visit a NISSAN dealer for this service.

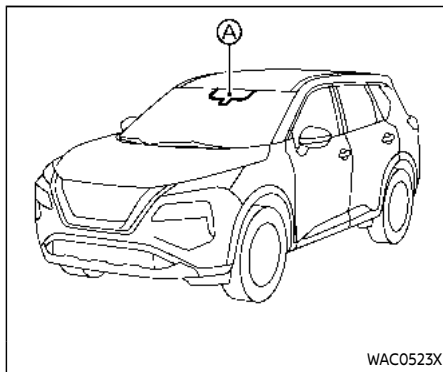

SYSTEM MAINTENANCE

The lane camera unit (A) for the I-LI system is located above the inside mirror. To keep the proper operation of the I-LI system and prevent a system malfunction, be sure to observe the following:

- Always keep the windshield clean.
- Do not attach a sticker (including transparent material) or install an accessory near the camera unit.
- Do not place reflective materials, such as white paper or a mirror, on the instrument panel. The reflection of sunlight may adversely affect the camera unit's capability of detecting the lane markers.

- Do not strike or damage the areas around the camera unit. Do not touch the camera lens or remove the screw located on the camera unit. If the camera unit is damaged due to an accident, it is recommended that you visit a NISSAN dealer.

BLIND SPOT WARNING (BSW)

WARNING

Failure to follow the warnings and instructions for proper use of the BSW system could result in serious injury or death.

- The BSW system is not a replacement for proper driving procedure and is not designed to prevent contact with vehicles or objects. When changing lanes, always use the side and rear mirrors and turn and look in the direction your vehicle will move to ensure it is safe to change lanes. Never rely solely on the BSW system.

The BSW system helps alert the driver of other vehicles in adjacent lanes when changing lanes.

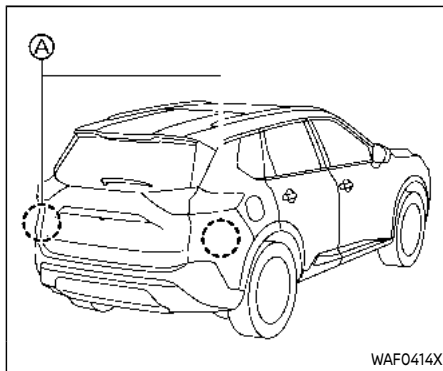

The BSW system uses radar sensors  installed near the rear bumper to detect other vehicles in an adjacent lane.

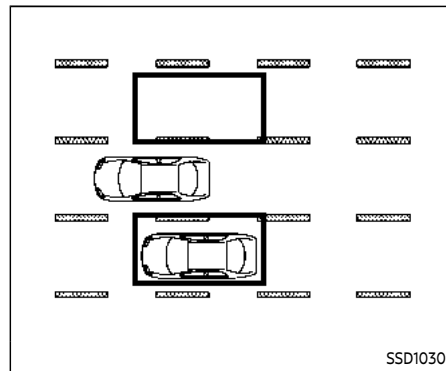

Detection zone

The radar sensors can detect vehicles on either side of your vehicle within the detection zone shown as illustrated. This detection zone starts from the outside mirror of your vehicle and extends approximately 10 ft (3.0 m) behind the rear bumper, and approximately 10 ft (3.0 m) sideways.

When the turn signal is activated, the detection zone may extend more than approximately 10 ft (3.0 m).

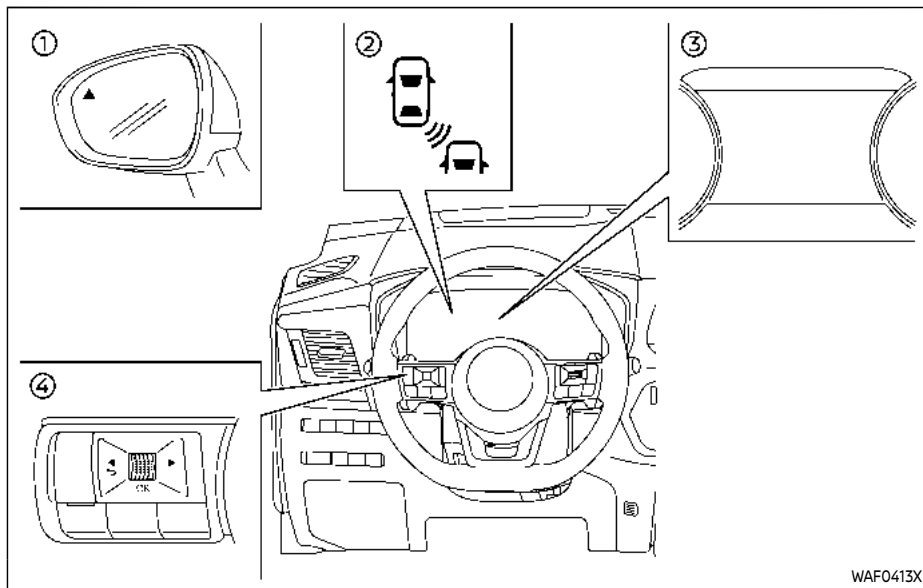

system chimes (twice) and the side indicator light flashes. The side indicator light continues to flash until the detected vehicle leaves the detection zone.

The side indicator light illuminates for a few seconds when the ignition switch is placed in the ON position.

The brightness of the side indicator light is adjusted automatically depending on the brightness of the ambient light.

- ① Side indicator light
- ② BSW indicator (on the vehicle information display)
- ③ Vehicle information display
- ④ Steering-wheel-mounted controls (left side)

BSW SYSTEM OPERATION

The BSW system operates above approximately 20 MPH (32 km/h).

If the radar sensors detect a vehicle in the detection zone, the side indicator light illuminates.

If the turn signal is then activated, the

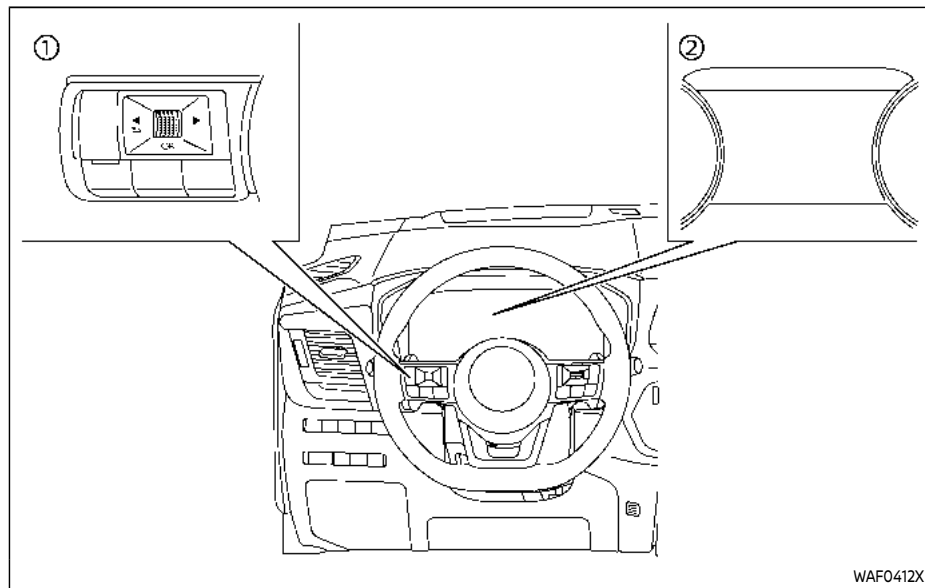

- ① Steering-wheel-mounted controls (left side)
- ② Vehicle information display

HOW TO ENABLE/DISABLE THE BSW SYSTEM

Perform the following steps to enable or disable the BSW system.

1. Push the ◀ ▶ button until "Settings" appears in the vehicle information display and then push the scroll

dial. Use the scroll dial to select "Driver Assistance". Then push the scroll dial.

2. Select "Blind Spot Assist" and push the scroll dial.
3. Select "Warning" and push the scroll dial.

NOTE:

The system will retain current settings in the vehicle information display even if the engine is restarted.

BSW SYSTEM LIMITATIONS

WARNING

Listed below are the system limitations for the BSW system. Failure to operate the vehicle in accordance with these system limitations could result in serious injury or death.

- The BSW system cannot detect all vehicles under all conditions.
- The radar sensors may not be able to detect and activate BSW when certain objects are present such as:
 - Pedestrians, bicycles, animals.
 - Vehicles such as motorcycles, low height vehicles, or high ground clearance vehicles.

- Oncoming vehicles.
- Vehicles remaining in the detection zone when you accelerate from a stop.
- A vehicle merging into an adjacent lane at a speed approximately the same as your vehicle.
- A vehicle approaching rapidly from behind.
- A vehicle which your vehicle overtakes rapidly.
- A vehicle that passes through the detection zone quickly.
- When overtaking several vehicles in a row, the vehicles after the first vehicle may not be detected if they are traveling close together.
- The radar sensor's detection zone is designed based on a standard lane width. When driving in a wider lane, the radar sensors may not detect vehicles in an adjacent lane. When driving in a narrow lane, the radar sensors may detect vehicles driving two lanes away.

- The radar sensors are designed to ignore most stationary objects, however objects such as guardrails, walls, foliage and parked vehicles may occasionally be detected. This is a normal operation condition.
- The following conditions may reduce the ability of the radar to detect other vehicles:
 - Severe weather
 - Road spray
 - Ice/frost/dirt build-up on the vehicle
- Do not attach stickers (including transparent material), install accessories or apply additional paint near the radar sensors. These conditions may reduce the ability of the radar to detect other vehicles.
- Excessive noise (for example, audio system volume, open vehicle window) will interfere with the chime sound, and it may not be heard.

BSW DRIVING SITUATIONS

Indicator on



Indicator off



Indicator flashing



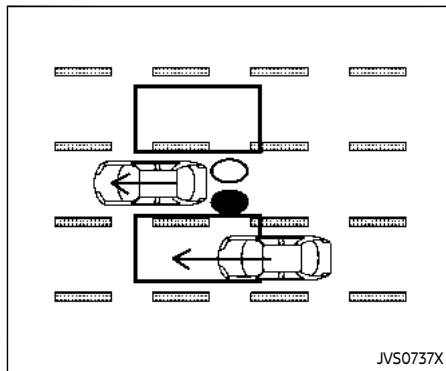

Illustration 1 – Approaching from behind

Another vehicle approaching from behind

Illustration 1: The side indicator light illuminates if a vehicle enters the detection zone from behind in an adjacent lane.

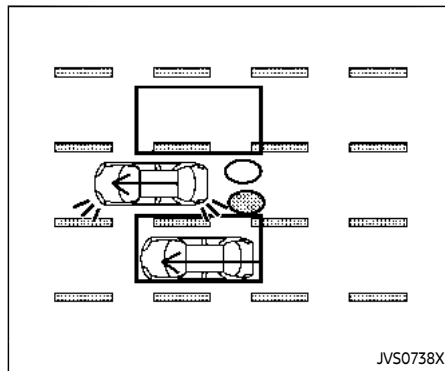

Illustration 2 – Approaching from behind

Illustration 2: If the driver activates the turn signal while another vehicle is in the detection zone, then the system chimes (twice) and the side indicator light flashes.

NOTE:

- **The radar sensors may not detect vehicles which are approaching rapidly from behind.**

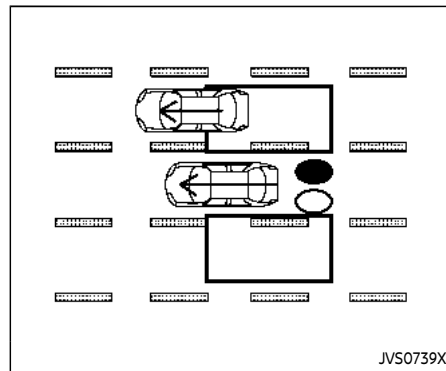

Illustration 3 – Overtaking another vehicle

Overtaking another vehicle

Illustration 3: The side indicator light illuminates if you overtake a vehicle and that vehicle stays in the detection zone for approximately 2 seconds.

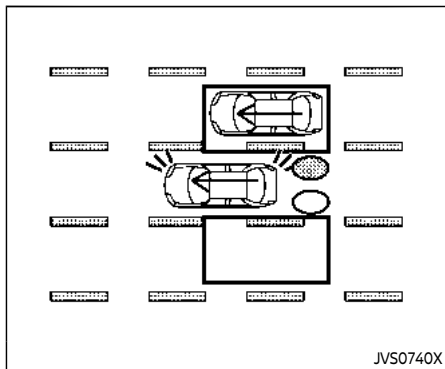

Illustration 4 - Overtaking another vehicle

Illustration 4: If the driver activates the turn signal while another vehicle is in the detection zone, then the system chimes (twice) and the side indicator light flashes.

NOTE:

- **When overtaking several vehicles in a row, the vehicles after the first vehicle may not be detected if they are traveling close together.**
- **The radar sensors may not detect slower moving vehicles if they are passed quickly.**
- **If the driver activates the turn signal before a vehicle enters the detection zone, the side indicator light will flash but no chime will sound when**

the other vehicle is detected.

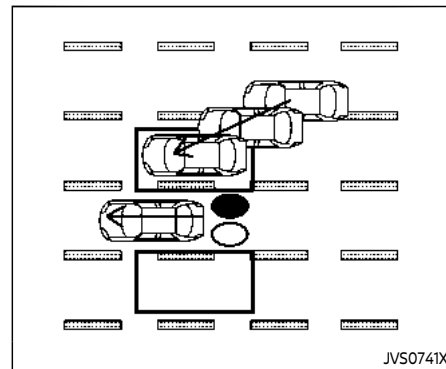

Illustration 5 - Entering from the side

Entering from the side

Illustration 5: The side indicator light illuminates if a vehicle enters the detection zone from either side.

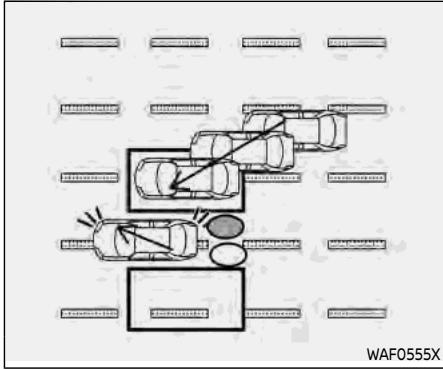

Illustration 6 – Entering from the side

Illustration 6: If the driver activates the turn signal while another vehicle is in the detection zone, then the system chimes (twice) and the side indicator light flashes.

NOTE:

- **The radar sensors may not detect a vehicle which is traveling at about the same speed as your vehicle when it enters the detection zone.**

SYSTEM TEMPORARILY UNAVAILABLE

When radar blockage is detected, the BSW system will be turned off automatically, a chime will sound and the "Unavailable Side Radar Obstruction" warning message will appear in the vehicle information display.

The system is not available until the conditions no longer exist.

The radar sensors may be blocked by temporary ambient conditions such as splashing water, mist or fog. The blocked condition may also be caused by objects such as ice, frost or dirt obstructing the radar sensors.

NOTE:

If the BSW system stops working, the Intelligent Blind Spot Intervention (I-BSI) (if so equipped) and the Rear Cross Traffic Alert (RCTA) systems will also stop working.

Action to take:

When the above conditions no longer exist, the system will resume automatically.

SYSTEM MALFUNCTION

When the BSW system malfunctions, it will be turned off automatically, the BSW indicator illuminates and the "Not Available System Malfunction" warning message will appear in the vehicle information display.

NOTE:

If the BSW system stops working, the Intelligent Blind Spot Intervention (I-BSI) (if so equipped) and Rear Cross Traffic Alert (RCTA) systems will also stop working.

Action to take:

Stop the vehicle in a safe location, turn the engine off and restart the engine. If the message continues to appear, have the BSW system checked. It is recommended that you visit a NISSAN dealer for this service.

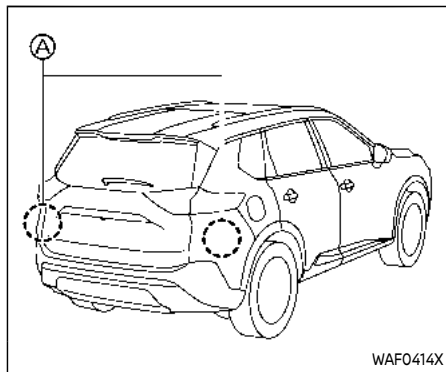

SYSTEM MAINTENANCE

The two radar sensors **A** for the BSW system are located near the rear bumper. Always keep the area near the radar sensors clean.

The radar sensors may be blocked by temporary ambient conditions such as splashing water, mist or fog.

The blocked condition may also be caused by objects such as ice, frost or dirt obstructing the radar sensors.

Check for and remove objects obstructing the area around the radar sensors.

Do not attach stickers (including transparent material), install accessories or

apply additional paint near the radar sensors.

Do not strike or damage the area around the radar sensors.

See a NISSAN dealer or other authorized repair shop if the area around the radar sensors is damaged due to a collision.

Radio frequency statement

For USA

FCC ID: LTQRN5TR

CAUTION TO USERS

Changes or modifications not expressly approved by the party responsible for compliance could void the user's authority to operate the equipment.

This device complies with Part 15 of the FCC Rules and with RSS of the Industry Canada. Operation is subject to the following two conditions:

(1) This device may not cause harmful interference, and

(2) this device must accept any interference received, including interference that may cause undesired operation

For Canada

Model: RN5TR

IC: 3659A-RN5TR

This device complies with Industry Ca-

nada licence-exempt RSS standard(s). Operation is subject to the following two conditions: (1) this device may not cause interference, and (2) this device must accept any interference, including interference that may cause undesired operation of the device.

INTELLIGENT BLIND SPOT INTERVENTION (I-BSI) (if so equipped)

WARNING

Failure to follow the warnings and instructions for proper use of the I-BSI system could result in serious injury or death.

- The I-BSI system is not a replacement for proper driving procedures and is not designed to prevent contact with vehicles or objects. When changing lanes, always use the side and rear mirrors and turn and look in the direction your vehicle will move to ensure it is safe to change lanes. Never rely solely on the I-BSI system.
- There is a limitation to the detection capability of the radar. Not every moving object or vehicle will be detected. Using the I-BSI system under some road, ground, lane marker, traffic or weather conditions could lead to improper system operation. Always rely on your own operation to avoid accidents.

driver to return the vehicle to the center of the traveling lane.

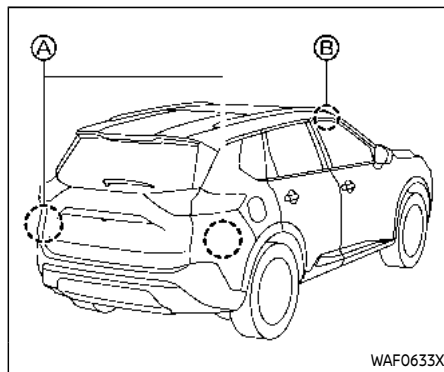

The I-BSI system uses radar sensors **A** installed near the rear bumper to detect other vehicles in an adjacent lane. In addition to the radar sensors, the I-BSI system uses a camera **B** installed behind the windshield to monitor the lane markers of your traveling lane.

The I-BSI system helps alert the driver of other vehicles in adjacent lanes when changing lanes, and helps assist the

5-66 **Starting and driving**

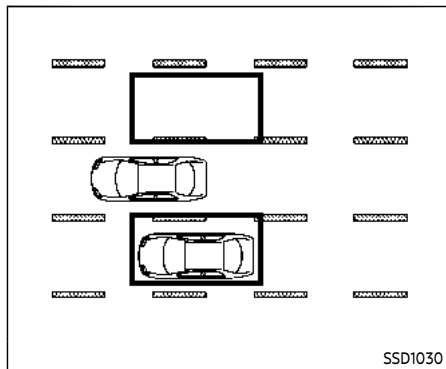

Detection zone

The radar sensors can detect vehicles on either side of your vehicle within the detection zone shown as illustrated.

This detection zone starts from the outside mirror of your vehicle and extends approximately 10 ft (3.0 m) behind the rear bumper, and approximately 10 ft (3.0 m) sideways.

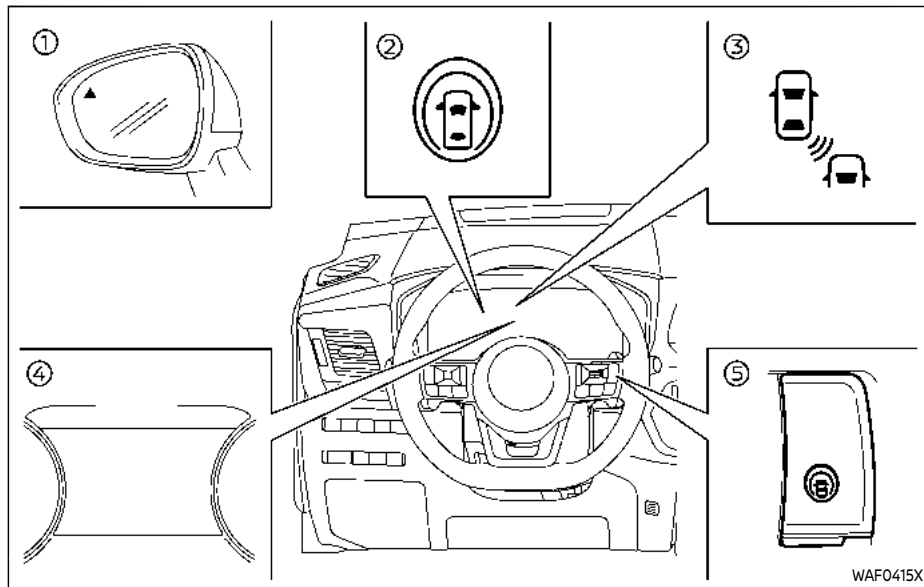

- ① Side indicator light
- ② I-BSI ON indicator (on the vehicle information display)
- ③ I-BSI indicator (on the vehicle information display)
- ④ Vehicle information display
- ⑤ ProPILOT Assist switch

I-BSI SYSTEM OPERATION

The I-BSI system operates above approximately 37 MPH (60 km/h).

If the radar sensors detect a vehicle in the detection zone, the side indicator light illuminates.

If the turn signal is then activated, the

system chimes (twice) and the side indicator light flashes. The side indicator light continues to flash until the detected vehicle leaves the detection zone.

If the I-BSI system is ON and your vehicle approaches a lane marker while another vehicle is in the detection zone, the system chimes (three times) and the side indicator light flashes. The I-BSI system activates to help return the vehicle back to the center of the driving lane. The I-BSI system operates regardless of turn signal usage.

To turn on the I-BSI system, push the ProPILOT Assist switch on the steering wheel after starting the engine. The I-BSI ON indicator on the vehicle information display will illuminate. Push the ProPILOT Assist switch again to turn off the I-BSI system.

NOTE:

- **I-BSI warning and system application will only be activated if the side indicator light is already illuminated when your vehicle approaches a lane marker. If another vehicle comes into the detection zone after your vehicle has crossed a lane marker, no I-BSI warning or system application will be activated. (For additional information, see "I-BSI driving situations" (P.5-71).)**

- **The I-BSI system is typically activated earlier than the Intelligent Lane Intervention (I-LI) system when your vehicle is approaching a lane marker.**

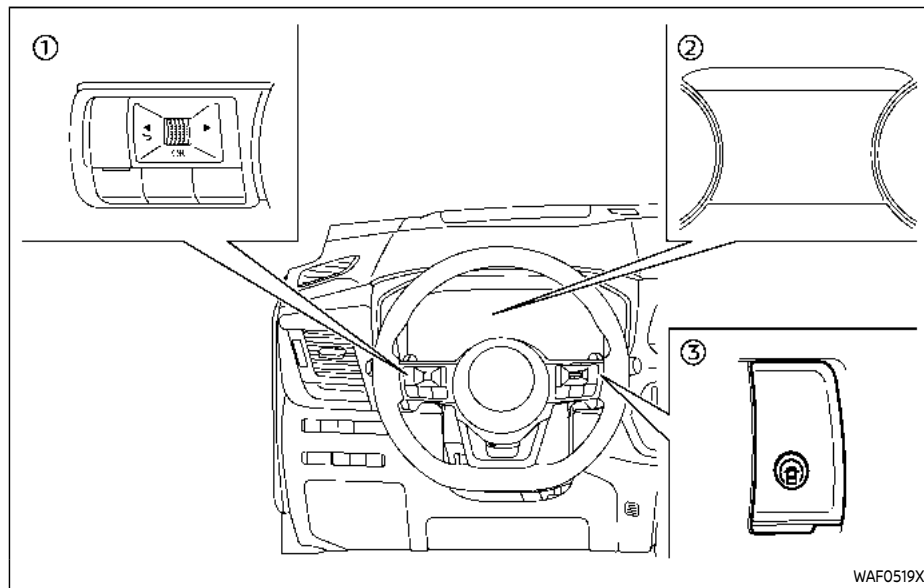

- ① Steering-wheel-mounted control (left side)
- ② Vehicle information display
- ③ ProPILOT Assist switch

HOW TO ENABLE/DISABLE THE I-BSI SYSTEM

1. Push the ◀ ▶ button until "Settings" appears in the vehicle information display and then push the scroll dial. Use the scroll dial to select "Driver Assistance." Then push the scroll dial.

2. Select "Blind Spot Assist" and push the scroll dial.
3. Select "Intervention" and push the scroll dial.
4. Push the ProPILOT Assist switch to turn the system on or off.

NOTE:

Turning on the ProPILOT Assist system will turn on the I-BSI and I-LI systems at the same time. For additional information, see "Intelligent Lane Intervention (I-LI)" (P.5-52).

Turning the BSW system off will deactivate the I-BSI system at the same time.

I-BSI SYSTEM LIMITATIONS

WARNING

Listed below are the system limitations for the I-BSI system. Failure to operate the vehicle in accordance with these system limitations could result in serious injury or death.

- The I-BSI system cannot detect all vehicles under all conditions.
- The radar sensors may not be able to detect and activate I-BSI when certain objects are present such as:

- Pedestrians, bicycles, animals.
- Vehicles such as motorcycles, low height vehicles, or high ground clearance vehicles.
- Vehicles remaining in the detection zone when you accelerate from a stop.
- Oncoming vehicles.
- A vehicle merging into an adjacent lane at a speed approximately the same as your vehicle.
- A vehicle approaching rapidly from behind.
- A vehicle which your vehicle overtakes rapidly.
- A vehicle that passes through the detection zone quickly.
- The radar sensor's detection zone is designed based on a standard lane width. When driving in a wider lane, the radar sensors may not detect vehicles in an adjacent lane. When driving in a narrow lane, the radar sensors may detect vehicles driving two lanes away.

- The radar sensors are designed to ignore most stationary objects, however objects such as guardrails, walls, foliage and parked vehicles may occasionally be detected. This is a normal operation condition.
- The following conditions may reduce the ability of the radar to detect other vehicles:
 - Severe weather
 - Road spray
 - Ice/frost/dirt build-up on the vehicle
- Do not attach stickers (including transparent material), install accessories or apply additional paint near the radar sensors. These conditions may reduce the ability of the radar to detect other vehicles.
- The camera may not detect lane markers in the following situations and the I-BSI system may not operate properly.
 - On roads where there are multiple parallel lane markers; lane markers that are faded or not painted clearly; yellow painted lane markers; non-

- standard lane markers; lane markers covered with water, dirt, snow, etc.
- On roads where discontinued lane markers are still detectable.
- On roads where there are sharp curves.
- On roads where there are sharply contrasting objects, such as shadows, snow, water, wheel ruts, seams or lines remaining after road repairs.
- On roads where the traveling lane merges or separates.
- When the vehicle's traveling direction does not align with the lane markers.
- When traveling close to the vehicle in front of you, which obstructs the lane camera unit detection range.
- When rain, snow or dirt adheres to the windshield in front of a lane camera unit.
- When the headlights are not bright due to dirt on the lens or if aiming is not adjusted

properly.

- When strong light enters a lane camera unit. (For example: light directly shines on the front of the vehicle at sunrise or sunset.)
- When a sudden change in brightness occurs. (For example: when the vehicle enters or exits a tunnel or under a bridge.)
- Do not use the I-BSI system under the following conditions because the system may not function properly.
 - During bad weather. (For example: rain, fog, snow, etc.)
 - When driving on slippery roads, such as on ice or snow, etc.
 - When driving on winding or uneven roads.
 - When there is a lane closure due to road repairs.
 - When driving in a makeshift or temporary lane.
 - When driving on roads where the lane width is too narrow.

- When driving with a tire that is not within normal tire conditions (for example, tire wear, low tire pressure, installation of spare tire, tire chains, non-standard wheels).
- When the vehicle is equipped with non-original steering parts or suspension parts.
- When towing a trailer or other vehicle.
- Excessive noise (for example, audio system volume, open vehicle window) will interfere with the chime sound, and it may not be heard.

I-BSI DRIVING SITUATIONS

Indicator on



Indicator off



Indicator flashing



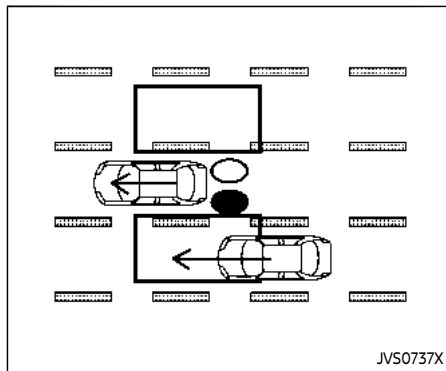

Illustration 1 – Approaching from behind

Another vehicle approaching from behind

Illustration 1: The side indicator light illuminates if a vehicle enters the detection zone from behind in an adjacent lane.

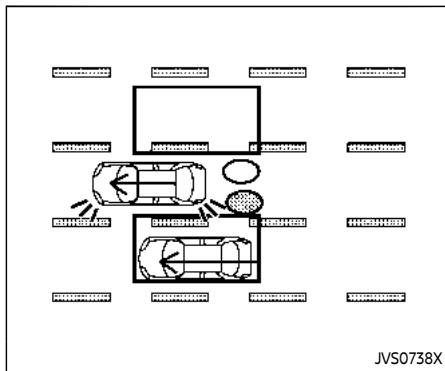

Illustration 2 – Approaching from behind

Illustration 2: If the driver activates the turn signal then the system chimes a sound (twice) and the side indicator light flashes.

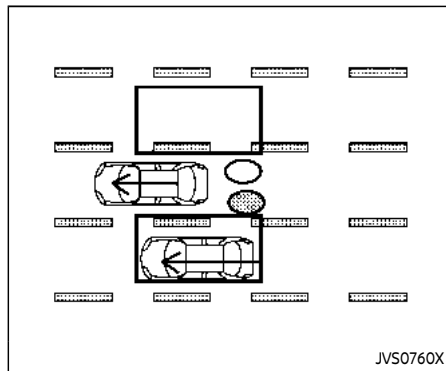

Illustration 3 - Approaching from behind

Illustration 3: If the I-BSI system is on and your vehicle approaches a lane marker while another vehicle is in the detection zone, the system chimes (three times) and the side indicator light flashes. The I-BSI system activates to help return the vehicle back to the center of the driving lane.

NOTE:

- The radar sensors may not detect vehicles which are approaching rapidly from behind.

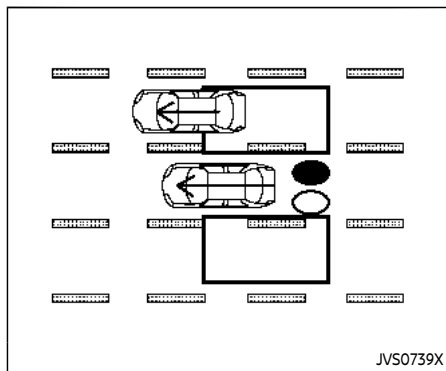

Illustration 4 - Overtaking another vehicle

Overtaking another vehicle

Illustration 4: The side indicator light illuminates if you overtake a vehicle and that vehicle stays in the detection zone for approximately 3 seconds.

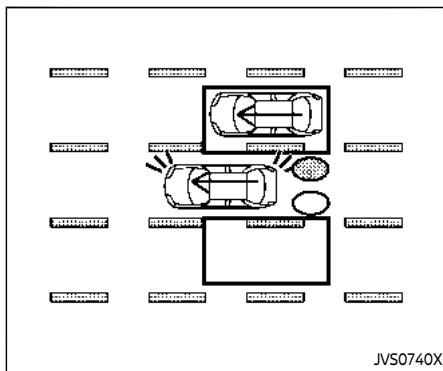

Illustration 5 - Overtaking another vehicle

Illustration 5: If the driver activates the turn signal while another vehicle is in the detection zone, then the system chimes (twice) and the side indicator light flashes.

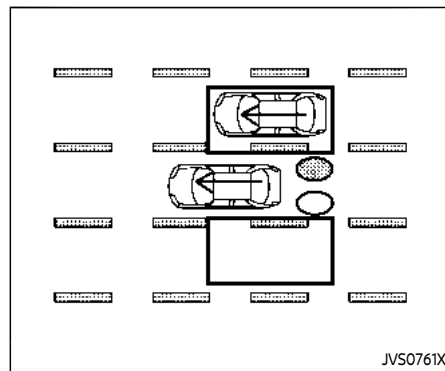

Illustration 6 - Overtaking another vehicle

Illustration 6: If the I-BSI system is on and your vehicle approaches a lane marker while another vehicle is in the detection zone, the system chimes (three times) and the side indicator light flashes. The I-BSI system activates to help return the vehicle back to the center of the driving lane.

NOTE:

- **When overtaking several vehicles in a row, the vehicles after the first vehicle may not be detected if they are traveling close together.**
- **The radar sensors may not detect slower moving vehicles if they are passed quickly.**

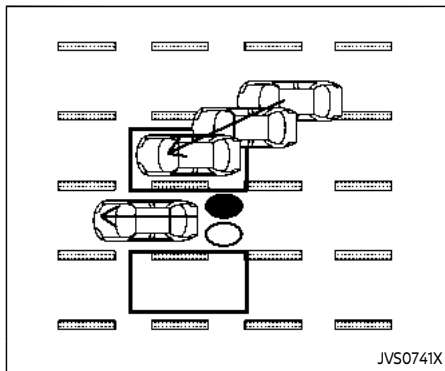

Illustration 7 - Entering from the side

Entering from the side

Illustration 7: The side indicator light illuminates if a vehicle enters the detection zone from either side.

NOTE:

The radar sensors may not detect a vehicle which is traveling at about the same speed as your vehicle when it enters the detection zone.

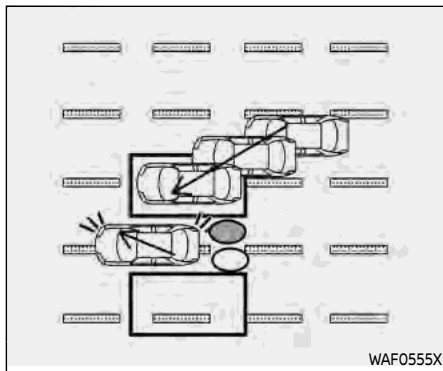

Illustration 8 - Entering from the side

Illustration 8: If the driver activates the turn signal while another vehicle is in the detection zone, then the side indicator light flashes and a chime will sound twice.

NOTE:

If the driver activates the turn signal before a vehicle enters the detection zone, the side indicator light will flash but no chime will sound when another vehicle is detected.

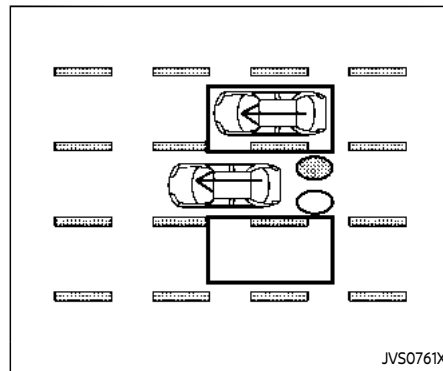

Illustration 9 - Entering from the side

Illustration 9: If the I-BSI system is on and your vehicle approaches the lane marker while another vehicle is in the detection zone, the system chimes (three times) and the side indicator light flashes. The I-BSI system activates to help return the vehicle back to the center of the driving lane.

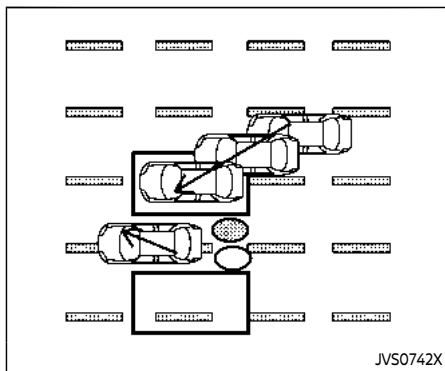

Illustration 10 - Entering from the side

Illustration 10: The I-BSI system will not operate if your vehicle is on a lane marker when another vehicle enters the detection zone. In this case only the BSW system operates.

NOTE:

- **The radar sensors may not detect a vehicle which is traveling at about the same speed as your vehicle when it enters the detection zone.**
- **I-BSI will not operate or will stop operating and only a warning chime will sound under the following conditions.**

- **When the brake pedal is depressed.**
- **When the vehicle is accelerated during I-BSI system operation**
- **When steering quickly**
- **When the ICC, I-FCW or AEB warnings sound.**
- **When the hazard warning flashers are operated.**
- **When driving on a curve at a high speed.**
- **When the BSW system is turned off.**

SYSTEM TEMPORARILY UNAVAILABLE

When any of the following messages appear on the vehicle information display, a chime will sound and the I-BSI system will be turned off automatically.

- **“Not Available Poor Road Conditions”:**
When the VDC system (except traction control system function) or ABS operates.
- **“Currently not available”:**
 - When the VDC system is turned off.
 - When the SNOW mode and the OFF-ROAD mode is selected (AWD models).

- **“Unavailable High Cabin Temperature”:**
If the vehicle is parked in direct sunlight under high temperature conditions (over approximately 104°F (40°C)).
- **“Unavailable Side Radar Obstruction”:**
When side radar blockage is detected. Turn off the I-BSI system and turn it on again when the above conditions no longer exist.

SYSTEM MALFUNCTION

When the I-BSI system malfunctions, it will be turned off automatically, the I-BSI indicator illuminates and a chime will sound, and the “Not Available System Malfunction” warning message will appear in the vehicle information display.

Action to take:

Stop the vehicle in a safe location and push the park button to engage the P (Park) position. Turn the engine off and restart the engine. If the warning message continues to appear, it is recommended you visit a NISSAN dealer for this service.

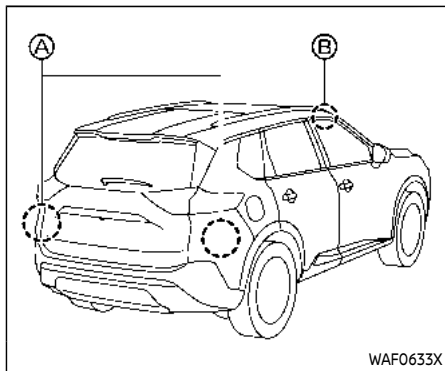

SYSTEM MAINTENANCE

The two radar sensors **A** for the I-BSI system are located near the rear bumper. Always keep the area near the radar sensors clean.

The radar sensors may be blocked by temporary ambient conditions such as splashing water, mist or fog.

The blocked condition may also be caused by objects such as ice, frost or dirt obstructing the radar sensors.

Check for and remove objects obstructing the area around the radar sensors.

Do not attach stickers (including transparent material), install accessories or

apply additional paint near the radar sensors.

Do not strike or damage the area around the radar sensors.

It is recommended you visit a NISSAN dealer if the area around the radar sensors is damaged due to a collision.

The lane camera unit **B** for I-BSI system is located above the inside mirror. To keep the proper operation of I-BSI and prevent a system malfunction, be sure to observe the following:

- Always keep the windshield clean.
- Do not attach a sticker (including transparent material) or install an accessory near the camera unit.
- Do not place reflective materials, such as white paper or a mirror, on the instrument panel. The reflection of sunlight may adversely affect the camera unit's capability of detecting the lane markers.
- Do not strike or damage the areas around the camera unit. Do not touch the camera lens or remove the screw located on the camera unit. It is recommended you contact a NISSAN dealer if the camera unit is damaged due to an accident.

Radio frequency statement

For USA

FCC ID: LTQRN5TR

CAUTION TO USERS

Changes or modifications not expressly approved by the party responsible for compliance could void the user's authority to operate the equipment.

This device complies with Part 15 of the FCC Rules and with RSS of the Industry Canada. Operation is subject to the following two conditions:

(1) This device may not cause harmful interference, and

(2) this device must accept any interference received, including interference that may cause undesired operation

For Canada

Model: RN5TR

IC: 3659A-RN5TR

This device complies with Industry Canada licence-exempt RSS standard(s). Operation is subject to the following two conditions: (1) this device may not cause interference, and (2) this device must accept any interference, including interference that may cause undesired operation of the device.

REAR CROSS TRAFFIC ALERT (RCTA)

WARNING

Failure to follow the warnings and instructions for proper use of the RCTA system could result in serious injury or death.

- The RCTA system is not a replacement for proper driving procedures and is not designed to prevent contact with vehicles or objects. When backing out of a parking space, always use the side and rear mirrors and turn and look in the direction your vehicle will move. Never rely solely on the RCTA system.

The RCTA system will assist you when backing out from a parking space. When the vehicle is in reverse, the system is designed to detect other vehicles approaching from the right or left of the vehicle. If the system detects cross traffic, it will alert you.

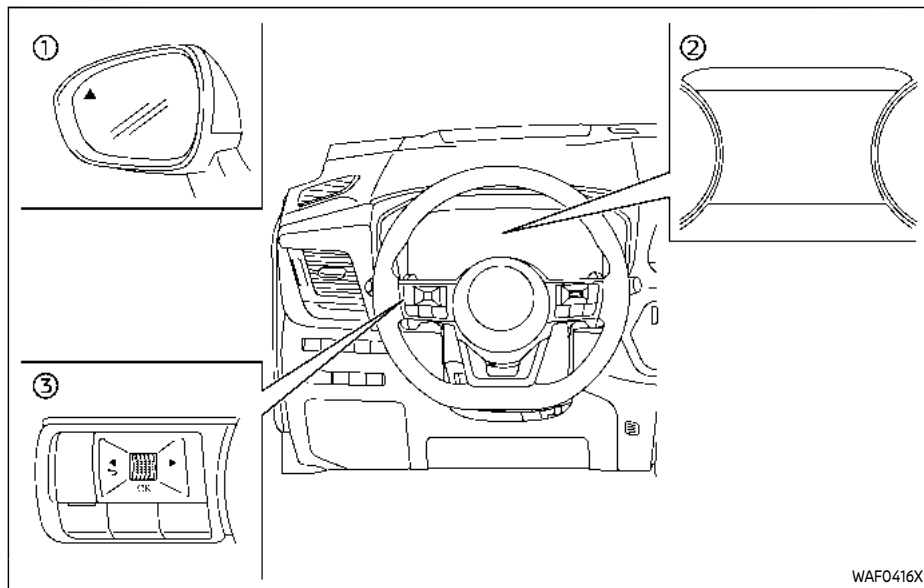

- ① Side indicator light
- ② Vehicle information display
- ③ Steering-wheel-mounted controls (left side)

RCTA SYSTEM OPERATION

The RCTA system can help alert the driver of an approaching vehicle when the driver is backing out of a parking space.

When the shift position is in R (Reverse) and the vehicle speed is less than approximately 5 MPH (8 km/h), the RCTA

system is operational.

If the radar detects an approaching vehicle from either side, the system chimes (once) and the side indicator light flashes on the side the vehicle is approaching from.

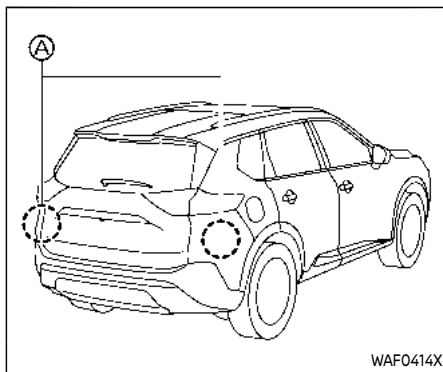
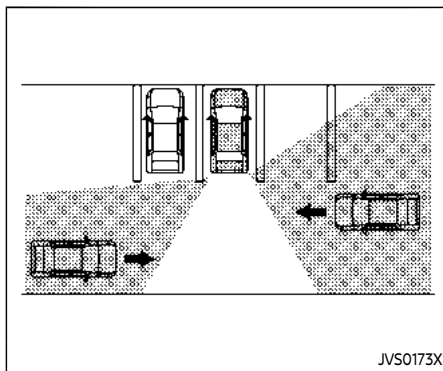

The RCTA system uses radar sensors **A** installed on both sides near the rear bumper to detect an approaching vehicle.

The radar sensors can detect an approaching vehicle from up to approximately 66 ft (20 m) away.

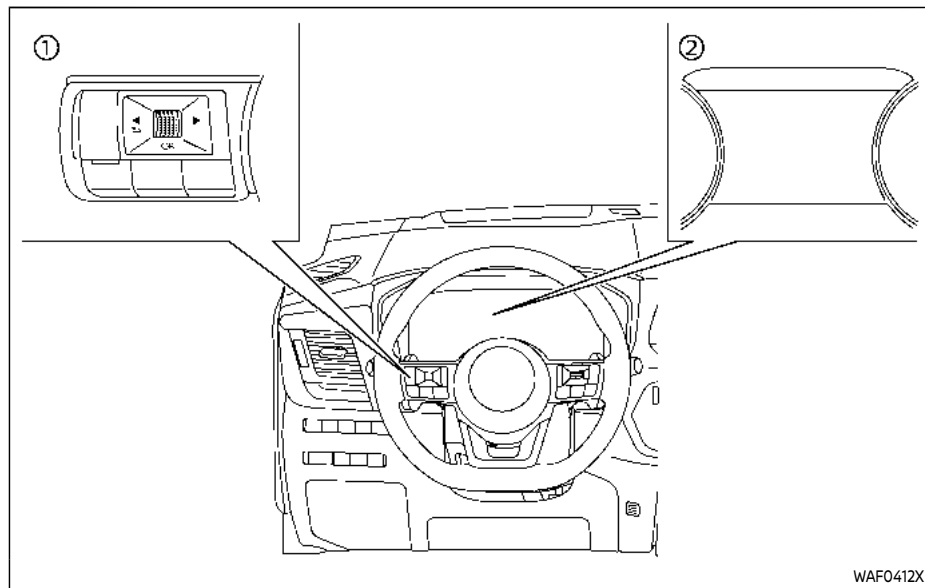

- ① Steering-wheel-mounted controls (left side)
- ② Vehicle information display

HOW TO ENABLE/DISABLE THE RCTA SYSTEM

Perform the following steps to enable or disable the RCTA system.

1. Push the ◀ ▶ button until "Settings" appears in the vehicle information display and then push the scroll

dial. Use the scroll dial to select "Driver Assistance". Then push the scroll dial.

2. Use the button to select "Rear Cross Traffic Alert" then press the scroll dial.
3. Use the scroll dial to enable or disable the system.

NOTE:

The system setting will be retained even if the engine is restarted.

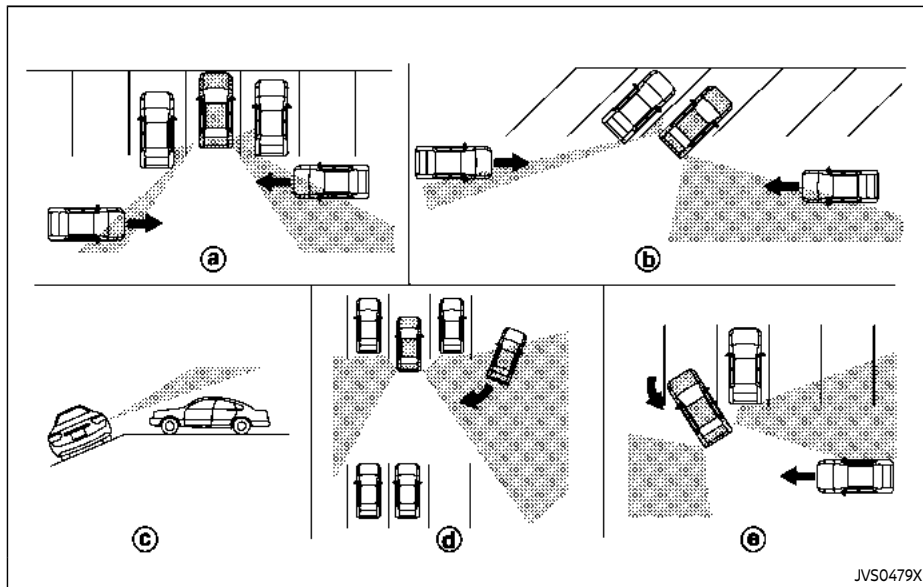

RCTA SYSTEM LIMITATIONS



WARNING

Listed below are the system limitations for the RCTA system. Failure to operate the vehicle in accordance with these system limitations could result in serious injury or death.

- Always check surroundings and turn to check what is behind you before backing up. The radar sensors detect approaching (moving) vehicles. The radar sensors cannot detect every object such as:
 - Pedestrians, bicycles, motorcycles, animals or child-operated toy vehicles
 - A vehicle that is passing at speeds greater than approximately 19 MPH (30 km/h)
 - A vehicle that is passing at speeds lower than approximately 5 MPH (8 km/h)
- The radar sensors may not detect approaching vehicles in certain situations:

- Illustration Ⓐ: When a vehicle parked next to you obstructs the beam of the radar sensor.
- Illustration Ⓑ: When the vehicle is parked in an angled parking space.
- Illustration Ⓒ: When the vehicle is parked on inclined ground.
- Illustration Ⓓ: When an approaching vehicle turns into your vehicle's parking lot aisle.
- Illustration Ⓔ: When the angle formed by your vehicle and approaching vehicle is small
- The following conditions may reduce the ability of the radar to detect other vehicles:
 - Severe weather
 - Road spray
 - Ice/frost/dirt build-up on the vehicle
- Do not attach stickers (including transparent material), install accessories or apply additional paint near the radar sensors. These conditions may reduce the ability of the radar to detect other vehicles

- Excessive noise (e.g. audio system volume, open vehicle window) will interfere with the chime sound, and it may not be heard.

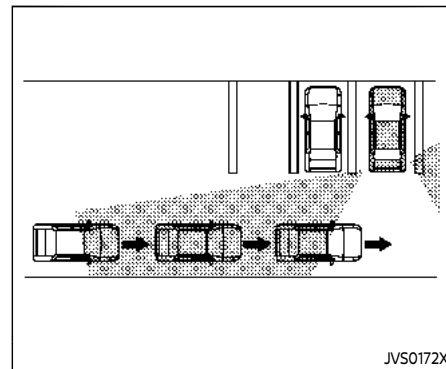

Illustration 1

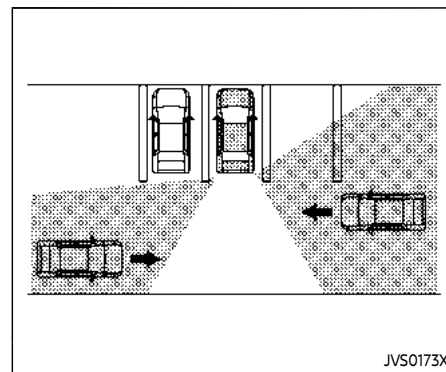

Illustration 2

NOTE:

In the case of several vehicles approaching in a row (Illustration 1) or in the opposite direction (Illustration 2), a chime may not be sounded by the RCTA system after the first vehicle passes the sensors.

SYSTEM TEMPORARILY UNAVAILABLE

When radar blockage is detected, the system will be deactivated automatically. The "Unavailable Side Radar Obstruction" warning message will appear in the vehicle information display.

The systems are not available until the conditions no longer exist.

The radar sensors may be blocked by temporary ambient conditions such as splashing water, mist or fog.

The blocked condition may also be caused by objects such as ice, frost or dirt obstructing the radar sensors.

NOTE:

If the BSW system stops working, the RCTA and Intelligent Blind Spot Intervention (I-BSI) (if so equipped) systems will also stop working.

Action to take:

When the above conditions no longer exist, the system will resume automatically.

cally.**SYSTEM MALFUNCTION**

When the RCTA system malfunctions, it will turn off automatically. The "Malfunction" warning message will appear in the vehicle information display.

NOTE:

If the BSW system stops working, the RCTA and I-BSI system will also stop working.

Action to take:

Stop the vehicle in a safe location, turn the engine off and restart the engine. If the message continues to appear, have the system checked. It is recommended that you visit a NISSAN dealer for this service.

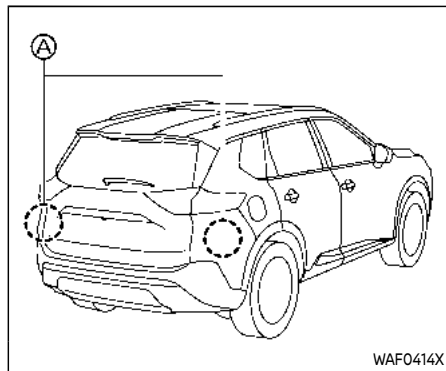
**SYSTEM MAINTENANCE**

The two radar sensors  for the RCTA system are located near the rear bumper. Always keep the area near the radar sensors clean.

The radar sensors may be blocked by temporary ambient conditions such as splashing water, mist or fog.

The blocked condition may also be caused by objects such as ice, frost or dirt obstructing the radar sensors.

Check for and remove objects obstructing the area around the radar sensors.

Do not attach stickers (including transparent material), install accessories or

apply additional paint near the radar sensors.

Do not strike or damage the area around the radar sensors. It is recommended that you visit a NISSAN dealer if the area around the radar sensors is damaged due to a collision.

Radio frequency statement

For USA

FCC ID: LTQRN5TR

CAUTION TO USERS

Changes or modifications not expressly approved by the party responsible for compliance could void the user's authority to operate the equipment.

This device complies with Part 15 of the FCC Rules and with RSS of the Industry Canada. Operation is subject to the following two conditions:

(1) This device may not cause harmful interference, and

(2) this device must accept any interference received, including interference that may cause undesired operation

For Canada

Model: RN5TR

IC: 3659A-RN5TR

This device complies with Industry Canada licence-exempt RSS standard(s).

Operation is subject to the following two conditions: (1) this device may not cause interference, and (2) this device must accept any interference, including interference that may cause undesired operation of the device.

CRUISE CONTROL (if so equipped)

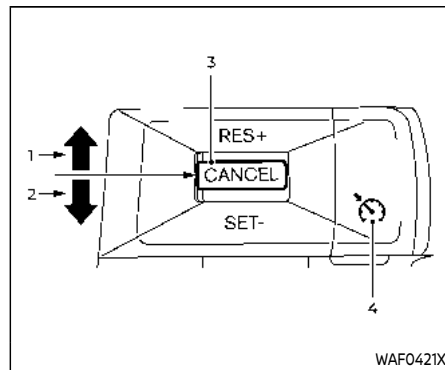

1. RES+ switch
2. SET- switch
3. CANCEL switch
4. Cruise ON/OFF switch

For models with the ProPILOT Assist system, see "Conventional (fixed speed) cruise control mode" (P.5-119).



WARNING

- Always observe the posted speed limits and do not set the speed over them.
- Do not use the cruise control when driving under the following

conditions. Doing so could cause a loss of vehicle control and result in an accident.

- **When it is not possible to keep the vehicle at a constant speed**
- **When driving in heavy traffic**
- **When driving in traffic that varies speed**
- **When driving in windy areas**
- **When driving on winding or hilly roads**
- **When driving on slippery (rain, snow, ice, etc.) roads**

PRECAUTIONS ON CRUISE CONTROL

- If the cruise control system malfunctions, it will cancel automatically. The cruise indicator in the vehicle information display will then blink to warn the driver.
- If the cruise indicator blinks and “Unavailable: Cruise system trouble” message appears in the display, turn the Cruise ON/OFF switch off and have the system checked. It is recommended that you visit a NISSAN dealer for this service.

- The cruise indicator may blink when the Cruise ON/OFF switch is turned ON while pushing up the RES+, pushing down the SET-, or pushing the CANCEL switch. To properly set the cruise control system, perform the following procedures.

CRUISE CONTROL OPERATIONS

The cruise control allows driving at speeds above 25 MPH (40 km/h) without keeping your foot on the accelerator pedal.

The cruise control will automatically be canceled if the vehicle slows down more than approximately 8 MPH (13 km/h) below the vehicle set speed. (“Unavailable: Under specified speed” message appears in the display.)

Moving the shift lever to the N (Neutral) position will cancel the cruise control.

Turning on cruise control

Push the Cruise ON/OFF switch. The cruise indicator and “Standby Push SET- to active” message in the vehicle information display will appear.

Setting cruising speed

1. Accelerate to the desired speed.
2. Push the SET- switch down or RES+ switch up and release it.
3. Take your foot off the accelerator pedal.

The vehicle will maintain the set speed. (“+ /- Change Set speed” message appears in the display.)

NOTE:

If pushed the RES+ switch and released it when there is no vehicle set speed, the set speed is set to the current vehicle speed.

Passing another vehicle:

Depress the accelerator pedal to accelerate. After releasing the accelerator pedal, the vehicle will return to the previously set speed.

The vehicle may not maintain the set speed when going up or down steep hills. In such cases, drive without the cruise control.

Resetting to slower speed:

Use any one of the following methods to reset to a slower speed.

- Lightly tap the foot brake pedal. When the vehicle reaches the desired speed, push down and release the SET-

PROPILOT ASSIST (if so equipped)

This section contains the information about the following system features:

- ProPILOT Assist (general system operation)
- ProPILOT Assist with Navi-link (additional functionality, if so equipped)



WARNING

Failure to follow the warnings and instructions for proper use of the ProPILOT Assist system could result in serious injury or death.

- **ProPILOT Assist is not a self-driving system. Within the limits of its capabilities, as described in this manual, it helps the driver with certain driving activities.**
- **The ProPILOT Assist system is not a replacement for proper driving procedures and is not designed to correct careless, inattentive or absent-minded driving. ProPILOT Assist will not always steer the vehicle to keep it in the lane. The ProPILOT Assist system is not designed to prevent loss of control. It is the driver's responsibility to stay alert, drive safely, keep the vehicle in the traveling lane, and be in control of the vehicle at**

switch.

- Push down and hold the SET- switch. When the vehicle reaches the desired speed, release the SET- switch.
- Quickly push down and release the SET- switch. This will reduce the vehicle speed by about 1 MPH (1.6 km/h).

Resetting to faster speed:

Use any one of the following methods to reset to a faster speed.

- Depress the accelerator pedal. When the vehicle reaches the desired speed, push down and release the SET- switch.
- Push up and hold the RES+ switch. When the vehicle reaches the desired speed, release the RES+ switch.
- Quickly push up and release the RES+ switch. This will increase the vehicle speed by about 1 MPH (1.6 km/h).

Resuming at preset speed:

Push up and release the RES+ switch.

The vehicle will resume the last set cruising speed when the vehicle speed is over 25 MPH (40 km/h). ("Resumed" message appears in the display.)

Cancelling cruising speed

Use any one of the following methods to cancel the vehicle set speed. ("Standby Push RES+ to resume" message appears in the display.)

- Push the CANCEL switch.
- Tap the foot brake pedal.
- Push the Cruise ON/OFF switch. The cruise indicator will turn off.

all times.

- There are limitations to the ProPILOT Assist system capability. The ProPILOT Assist system does not function in all driving, traffic, weather, and road conditions. It is the driver's responsibility to stay alert, drive safely, keep the vehicle in the traveling lane, and be in control of the vehicle at all times.
- The ProPILOT Assist system is only an aid to assist the driver and is not a collision warning or avoidance device.
- The ProPILOT Assist system is for highway use only and is not intended for city driving. Failure to apply the brakes or steer the vehicle when necessary may result in a serious accident.
- Always observe posted speed limits and do not set the speed over them.
- Never take your hands off the steering wheel when driving. Always keep your hands on the steering wheel and drive your vehicle safely.
- Never unfasten your safety belt when using ProPILOT Assist. Doing so automatically cancels

the ProPILOT Assist system.

- The ProPILOT Assist system does not react when approaching stationary and slow moving vehicles.
- Always drive carefully and attentively when using the ProPILOT Assist system. Read and understand the Owner's Manual thoroughly before using the ProPILOT Assist system. To avoid serious injury or death, do not rely on the system to prevent accidents or to control the vehicle's speed in emergency situations. Do not use the ProPILOT Assist system except in appropriate road and traffic conditions.

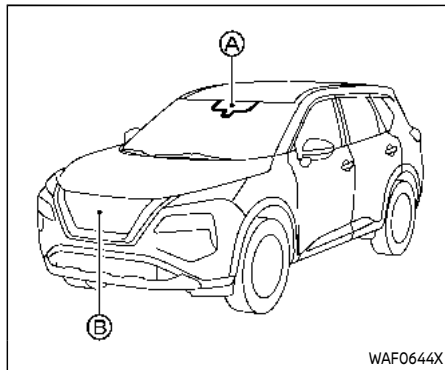

The ProPILOT Assist system is intended to enhance the operation of the vehicle when following a vehicle traveling in the same lane and direction.

The ProPILOT Assist system uses a multi-sensing front camera (A) installed behind the windshield to monitor the lane markers and a radar sensor (B) located on the front of the vehicle to measure the distance to the vehicle ahead in the same lane. If the system detects a slower moving vehicle ahead, the system will reduce the vehicle speed so that your vehicle follows the vehicle in front at the selected distance. The system will also help keep the vehicle centered in the traveling lane when clear lane markings

are detected.

NOTE:

It is important to ensure the front camera and radar sensors are clear at all times. (See "ICC sensor maintenance" (P.5-112) and "Steering Assist maintenance" (P.5-118) for more details.)

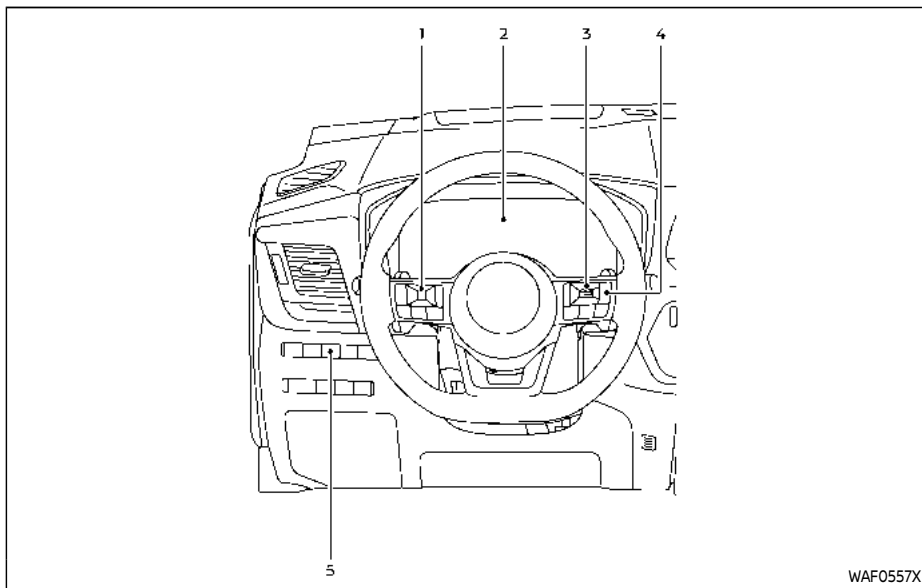

- ① Steering-wheel-mounted control (left)
- ② Vehicle information display
- ③ Steering-wheel-mounted control (right)
- ④ ProPILOT Assist switch
- ⑤ Steering Assist switch

PROPILOT ASSIST SYSTEM OPERATION

The ProPILOT Assist system has the following two functions:

1. Intelligent Cruise Control (ICC)

The ICC system can be set to one of two cruise control modes:

- Conventional (fixed speed) cruise control mode:

For cruising at a preset vehicle speed

For additional information, see “Turning the conventional (fixed speed) cruise control mode ON” (P.5-92).

NOTE:

Steering Assist is not available in the conventional (fixed speed) cruise control mode.

- Vehicle-to-vehicle distance control mode:

The ICC system maintains a selected distance from the vehicle in front of you within the speed range of 0 to 90 MPH (0 to 144 km/h) up to the vehicle set speed. The vehicle set speed can be selected by the driver between 20 to 90 MPH (30 to 144 km/h). When the vehicle ahead slows to a stop, your vehicle gradually decelerates to a standstill. When the vehicle is stopped, the ICC system maintains braking force to keep your vehicle stopped.

- When your vehicle is stopped for less than approximately 3 seconds and the vehicle ahead begins to move, your vehicle will start moving again auto-

matically.

- When your vehicle is at a standstill for more than approximately 3 seconds and the vehicle ahead begins to accelerate, push up the RES+ switch or lightly depress the accelerator pedal. The ICC system starts to follow the vehicle ahead.
- Always check surroundings before restarting the vehicle.
- For vehicles equipped with ProPILOT Assist with Navi-link and only when on a limited access freeway (as identified in the navigation map data):
 - The time the vehicle can remain stopped and automatically restart is extended from 3 seconds to 30 seconds.
 - If a vehicle ahead cuts in or out of the lane ahead, the vehicle may not automatically start when the traffic ahead begins to move. You need to push up the RES+ switch or lightly depress the accelerator pedal to follow the vehicle directly ahead when it is safe to do so.
- When no vehicle is detected ahead within the driver selected distance, the vehicle travels at the speed set by the driver. The speed must be above 20 MPH (30 km/h) to use this function.

NOTE:

Even if the Automatic Emergency Braking (AEB) setting is turned off by the driver using the “Settings” menu in the vehicle information display, AEB will be automatically turned on when ICC is used.

2. Steering Assist

The Steering Assist function helps the driver to keep the vehicle centered within the traveling lane.

When there is no vehicle ahead, Steering Assist is not available at speeds under 37 MPH (60 km/h).

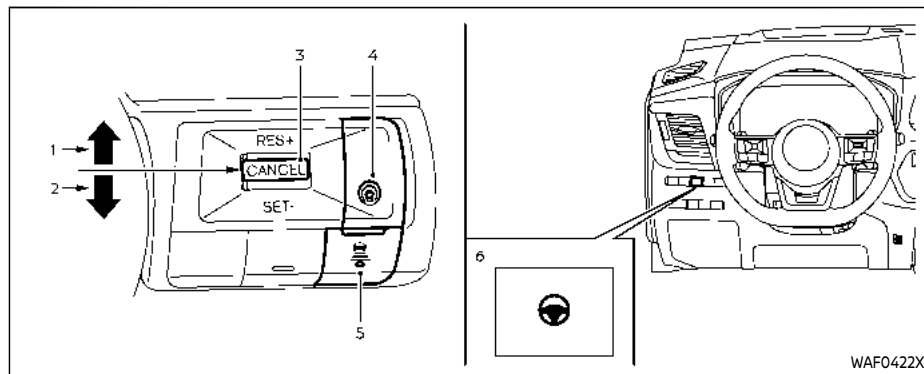

PROPILOT ASSIST SWITCHES

1. RES+ switch:
Resumes vehicle set speed or increases speed incrementally
2. SET- switch:
Sets desired cruise speed or reduces speed incrementally
3. CANCEL switch:
Deactivates the ProPILOT Assist system
4. ProPILOT Assist switch:
Turns the ProPILOT Assist system on or off

5. DISTANCE switch:
 - Long
 - Middle
 - Short
6. Steering Assist switch:
Turns the Steering Assist function on or off

NOTE:

For ProPILOT Assist with Navi-link equipped vehicles: When Manual mode is selected in the "Spd. Limit Assist" menu, operating the RES+ or SET- switch can apply the indicated speed limit to the vehicle set speed. (See "Speed Limit Assist - a feature of ProPI-

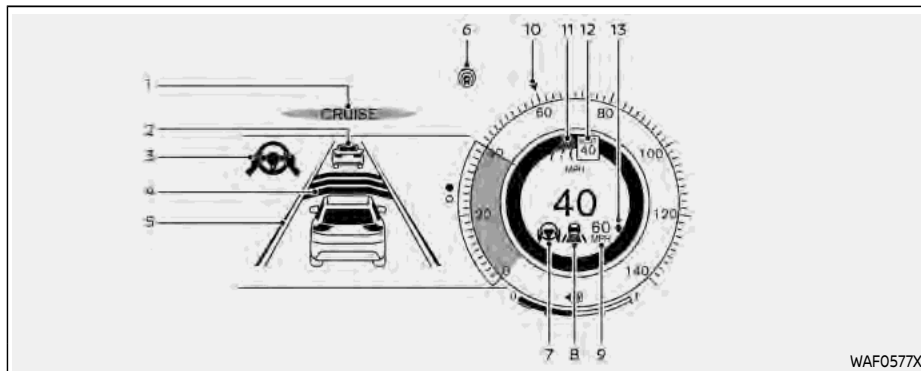

Models with full-screen display

WAF0577X

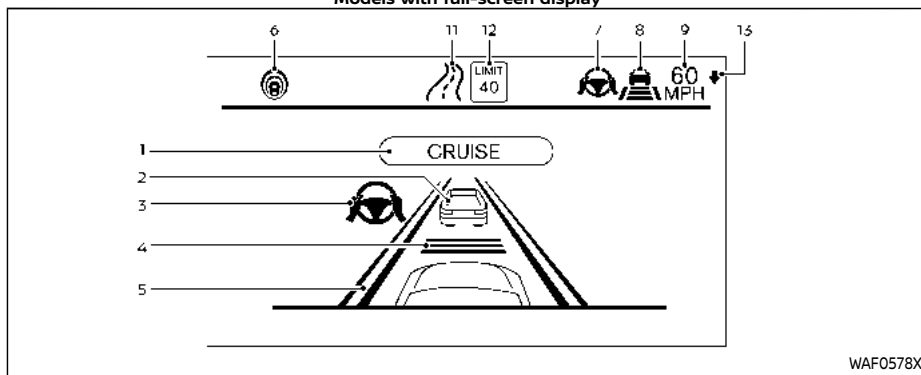

Models with analog meter and color display

WAF0578X

PROPILOT ASSIST SYSTEM DISPLAY AND INDICATORS

1. ProPILOT Assist activation

Displays once the ProPILOT Assist system is activated

2. Vehicle ahead detection indicator

Indicates whether the system detects a vehicle in front of you

3. Steering Assist indicator

Indicates the status of the Steering Assist function by the color of the indicator

- Steering Assist indicator (gray): Steering Assist standby
- Steering Assist indicator (green): Steering Assist active





4. Set distance indicator

Displays the selected distance



5. Lane marker indicator

Indicates whether the system detects lane markers

- No lane markers displayed: Steering Assist is turned off
- Lane marker indicator (gray): No lane markers detected
- Lane marker indicator (green): Lane markers detected, Steering Assist is active

- Lane marker indicator (orange): Lane departure is detected
6. **ProPILOT Assist status indicator** ()
- Indicates the status of the ProPILOT Assist system by the color of the indicator
- ProPILOT Assist status indicator (white): ProPILOT Assist is on but in standby
 - ProPILOT Assist status indicator (blue): ProPILOT Assist active
7. **Steering Assist status indicator/warning** (, )
- Displays the status of the Steering Assist by the color of the indicator/warning
- No Steering Assist status indicator displayed: Steering Assist is turned off
 - Steering Assist status indicator (gray): Steering Assist standby
 - Steering Assist status indicator (green): Steering Assist active
 - Steering Assist status indicator (orange): Steering Assist malfunction
8. **Speed control status indicator/set distance indicator/lane marker indicator** ()
- Displays the status of speed control by the color of the indicator, and displays

the selected distance by the number of horizontal bars shown

- Speed control status indicator (white): ICC standby
 - Speed control status indicator (green): ICC (distance control mode) is active
 - Green vehicle icon displayed: Vehicle detected ahead
 - No vehicle icon shown: No vehicle detected ahead (Your vehicle maintains the driver-selected set speed.)
 - Speed control status indicator (orange): Indicates an ICC malfunction
- For the lane marker indicator, see “Steering Assist display and indicators” (P.5-115).
9. **Vehicle set speed indicator**
- Indicates the vehicle set speed
10. **Vehicle set speed indicator (if so equipped)** ()
- Indicates the vehicle set speed
11. **Road information indicator (if so equipped)** (, )
- Indicates the detected road information
- For additional information, see “Speed Adjust by Route - a feature of ProPILOT Assist with Navi-link” (P.5-106).

12. **Detected speed limit indicator (if so equipped)** ()

Indicates the currently detected speed limit

For additional information, see “Speed Limit Assist - a feature of ProPILOT Assist with Navi-link” (P.5-103).

13. **Speed Limit Assist indicator (if so equipped)** (, )

Indicates the Speed Limit Assist activation mode or system operation

For additional information, see “Speed Limit Assist - a feature of ProPILOT Assist with Navi-link” (P.5-103).

NOTE:

When the ProPILOT Assist system is activated, the display will automatically be switched to the ProPILOT Assist system display. To disable this function, turn “Transition (Cruise)” off under “Customize Display” of the settings menu.

The ProPILOT Assist display is also shown in the Head Up Display (HUD) (if so equipped). (See “Head Up Display (HUD)” (P.2-50).)

TURNING THE CONVENTIONAL (fixed speed) CRUISE CONTROL MODE ON

NOTE:

ProPILOT Assist provides no approach warnings, automatic braking, or Steering Assist in the conventional (fixed speed) cruise control mode.

To choose the conventional (fixed speed) cruise control mode, push and hold the ProPILOT Assist switch for longer than approximately 1.5 seconds. For additional information, see "Conventional (fixed speed) cruise control mode" (P.5-119).

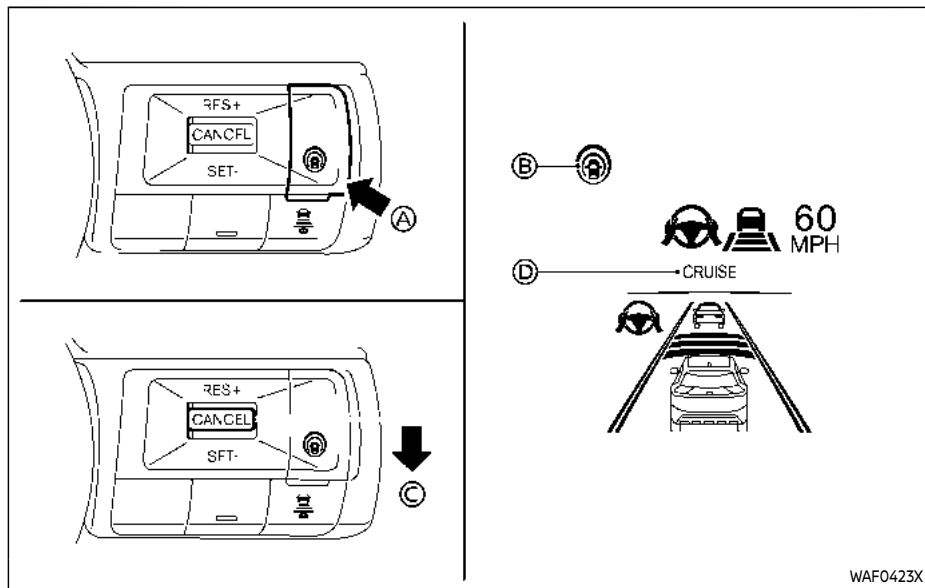

Example

OPERATING PROPILOT ASSIST

1. Push the ProPILOT Assist switch (A). This turns on the ProPILOT Assist system.
 - The ProPILOT Assist status indicator (B) illuminates in white.

- A screen is displayed for a period of time that indicates the status of the Driving Aid functions.

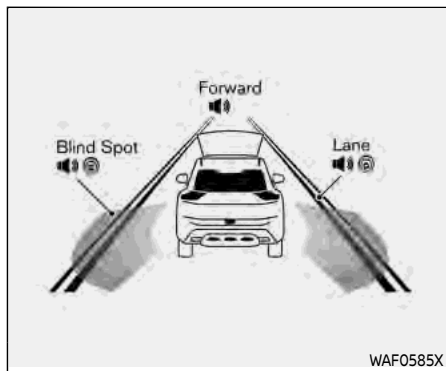

Example (all enabled)

When the Driving Aids are enabled:

Zone	Driving Aid	Display
Forward	Automatic Emergency Braking (AEB) with Pedestrian Detection	Outline
	Intelligent Forward Collision Warning (I-FCW)	
Lane	Lane Departure Warning (LDW)	Outline
	Intelligent Lane Intervention (I-LI)	Shaded
Blind Spot	Blind Spot Warning (BSW)	Outline
	Intelligent Blind Spot Intervention (I-BSI)	Shaded

- When any of the “Warning” systems are enabled, the “ ” mark is shown in each zone.
- When any of the “Intervention” systems are enabled, the “ ” mark is shown in each zone.
- When no system is enabled, “OFF” is shown in each zone.

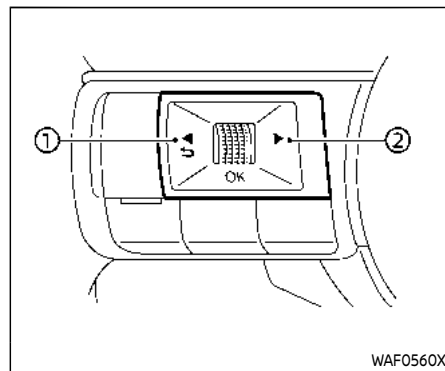

To change the status of the Driving Aids, use ① or ② to navigate the settings screen. For additional information, see “How to use the vehicle information display” (P.2-23).

2. Accelerate or decelerate your vehicle to the desired speed and push down the SET- switch .

The ProPILOT Assist system begins to automatically maintain the vehicle set speed. The ProPILOT Assist activation indicator and ProPILOT Assist status indicator illuminate in blue. When a vehicle ahead is detected and traveling at a speed of 20 MPH (30 km/h) or below and the SET- switch is pushed

down, the vehicle set speed is 20 MPH (30 km/h).

NOTE:

When the I-LI and I-BSI systems are enabled in the settings menu of the vehicle information display, turning the ProPILOT Assist system on will turn on the I-LI and I-BSI systems at the same time. If the I-LI system is disabled in the settings menu, the I-LI system will automatically be turned on when the Steering Assist system is active. For additional information, see "Intelligent Lane Intervention (I-LI)" (P.5-52), "Intelligent Lane Intervention (I-LI)" (P.5-115) and "Intelligent Blind Spot Intervention (I-BSI)" (P.5-66).

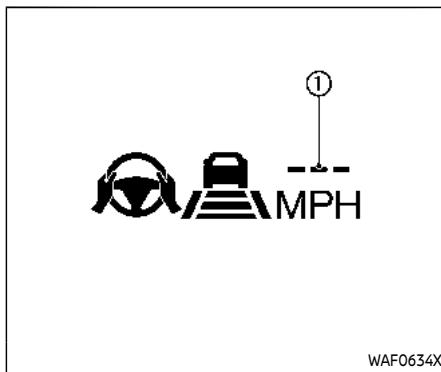

When the SET- switch is pushed down under the following conditions, the ProPILOT Assist system cannot be set and the vehicle set speed indicator ① blinks for approximately 2 seconds:

- When traveling below 20 MPH (30 km/h) and a vehicle ahead is not detected
- When the shift lever is moved out of the D (Drive) position or into the manual shift mode
- When the parking brake is applied
- When the brakes are operated by the driver
- When the VDC system is off. For additional information, see "Vehicle

Dynamic Control (VDC) system" (P.5-157).

- When the VDC system (including the traction control system) is activated
- When the SNOW mode or OFF-ROAD mode is selected (AWD models)
- When a wheel is slipping
- When any door is open
- When the driver's seat belt is not fastened

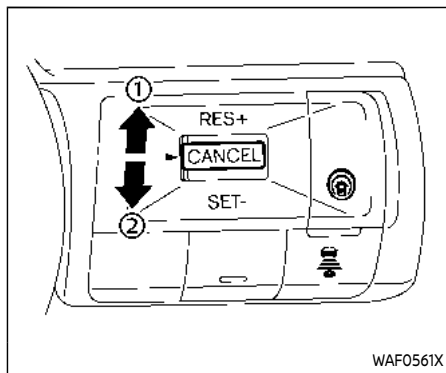

How to change the vehicle set speed

The vehicle set speed can be adjusted.

To change to a faster cruising speed:

- Push up and hold the RES+ switch ①. The vehicle set speed increases in increments of 5 MPH (5 km/h).
- Push up, then quickly release the RES+ switch ①. Each time you do this, the vehicle set speed increases by 1 MPH (1 km/h).

To change to a slower cruising speed:

- Push down and hold the SET- switch ②. The vehicle set speed decreases in increments of 5 MPH (5 km/h).

- Push down, then quickly release the SET- switch ②. Each time you do this, the vehicle set speed decreases by 1 MPH (1 km/h).

For ProPILOT Assist with Navi-link equipped vehicles: The vehicle set speed can also be changed according to the speed limit. (See “Speed Limit Assist - a feature of ProPILOT Assist with Navi-link” (P.5-103).)

How to momentarily accelerate or decelerate

- Depress the accelerator pedal when acceleration is required. Release the accelerator pedal to resume the previously set vehicle speed.
- Depress the brake pedal when deceleration is required. Control by the ProPILOT Assist system is canceled. Push up the RES+ switch to resume the previously set vehicle speed.



WARNING

When the accelerator pedal is depressed and you are approaching the vehicle ahead, the ICC system will neither control the brake nor warn the driver with the chime and display. The driver must manually control the vehicle speed to maintain

a safe distance to the vehicle ahead. Failure to do so could result in severe personal injury or death.

NOTE:

When you accelerate by depressing the accelerator pedal or decelerate by pushing down the SET- switch and the vehicle travels faster than the speed set by the driver, the vehicle set speed indicator will blink.

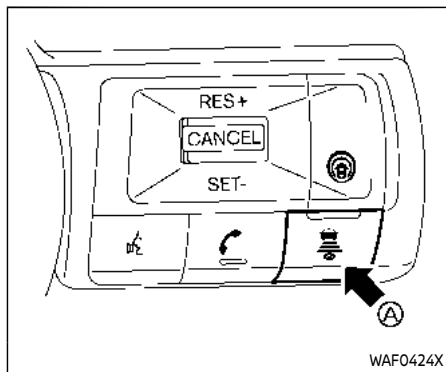

How to change the set distance to the vehicle ahead

The distance to the vehicle ahead can be selected at any time.

Each time the DISTANCE switch **A** is pushed, the set distance will change to "long", "middle", "short" and back to "long" again in that sequence.

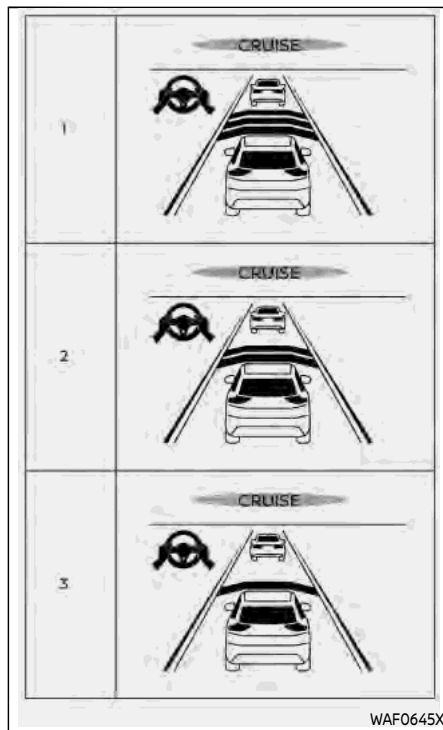

Example

Distance — approximate distance at 60 MPH (100 km/h)

1. Long - 200 ft (60 m)
2. Middle - 150 ft (45 m)
3. Short - 90 ft (30 m)

- The actual distance to the vehicle ahead adjusts automatically according to the vehicle speed. The higher the vehicle speed, the longer the distance.
- The distance setting will remain at the current setting even if the engine is restarted.

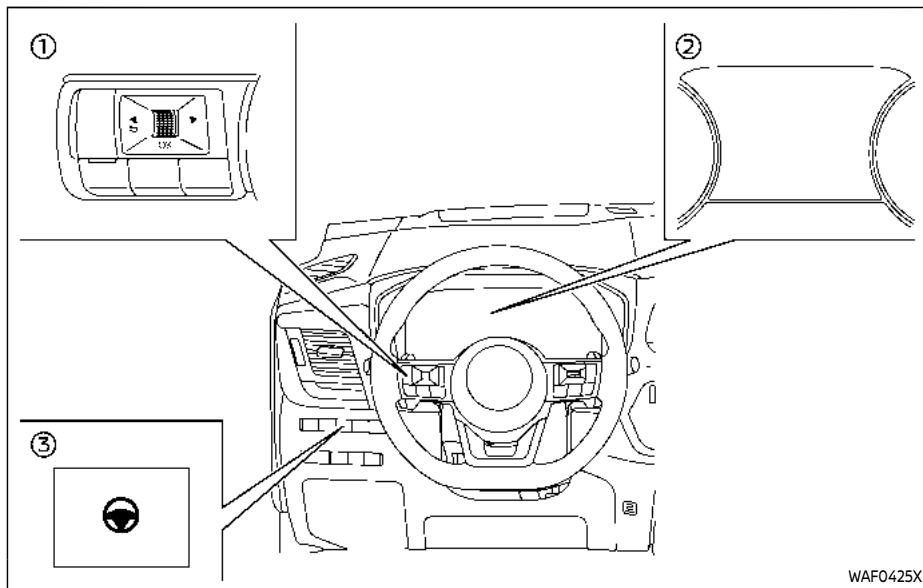

- ① Steering-wheel-mounted control (left)
- ② Vehicle information display
- ③ Steering Assist switch

HOW TO ENABLE/DISABLE THE STEERING ASSIST

Use the following methods to enable or disable the Steering Assist.

Steering Assist switch:

To turn the Steering Assist on or off, push the Steering Assist switch ③ on the instrument panel.

NOTE:

- When the Steering Assist switch is used to turn the system on or off, the system remembers the setting even if the ignition switch is cycled. The switch must be pushed again to change the setting to on or off.
- The Steering Assist switch changes the status of the "Steering Assist" selection made in the "Settings" screen in the vehicle information display.

Setting in the vehicle information display:

1. Push the ◀ ▶ button on the steering wheel ① until "Settings" appears in the vehicle information display ② and then push the scroll dial.
2. Use the scroll dial to select "Driver Assistance." Then push the scroll dial.
3. Select "Steering Assist" and push the scroll dial to turn the Steering Assist on or off.

NOTE:

- When the Cruise screen is displayed on the vehicle information display, push the scroll dial on the steering wheel to call up the "Driver Assistance" setting display.
- When enabling/disabling the system through the vehicle information display, the system retains the current settings even if the engine is restarted.

HOW TO CANCEL THE PROPILOT ASSIST SYSTEM

To cancel the ProPILOT Assist system, use one of the following methods:

- Push the CANCEL switch.
- Tap the brake pedal (except at a standstill).
- Push the ProPILOT Assist switch to turn the system off. The ProPILOT Assist status indicator will turn off.

When the ProPILOT Assist system is canceled while the vehicle is stopped, the electronic parking brake is automatically activated.



WARNING

To prevent the vehicle from moving or rolling unexpectedly, which could

result in serious personal injury or property damage, before exiting the vehicle make sure to push the ProPILOT Assist switch to turn the system off, push the park button to shift to the P (Park) position, and turn the engine off.

INTELLIGENT CRUISE CONTROL (ICC)

- The Intelligent Cruise Control (ICC) is a part of the ProPILOT Assist system. To choose the ICC system without the Steering Assist, activate the ProPILOT Assist and then turn off the Steering Assist with the switch or in the settings menu. For additional information, see "Operating ProPILOT Assist" (P.5-92) and "How to enable/disable the Steering Assist" (P.5-97).
- To choose the conventional (fixed speed) cruise control mode, push and hold the ProPILOT Assist switch for longer than approximately 1.5 seconds. For additional information, see "Conventional (fixed speed) cruise control mode" (P.5-119).



WARNING

Failure to follow the warnings and instructions for proper use of the ICC system could result in serious injury or death.

- The ICC system is only an aid to assist the driver and is not a collision warning or avoidance device. It is recommended for highway use only and it is not intended for city driving. It is the driver's responsibility to stay alert, drive safely, and be in control of the vehicle at all times.
- There are limitations to the ICC system capability. The ICC system does not function in all driving, traffic, weather, and road conditions. It is the driver's responsibility to stay alert, drive safely, keep the vehicle in the traveling lane, and be in control of the vehicle at all times.
- Always observe posted speed limits and do not set the speed over them.
- The ICC system does not react to stationary and slow moving vehicles.

- **Always drive carefully and attentively when using the ICC system. Read and understand the Owner's Manual thoroughly before using the ICC system. To avoid serious injury or death, do not rely on the system to prevent accidents or to control the vehicle's speed in emergency situations. Do not use the ICC system except in appropriate road and traffic conditions.**

ICC system operation

The ICC system is designed to maintain a selected distance from the vehicle in front of you and can reduce the speed to match a slower vehicle ahead. The system decelerates the vehicle as necessary and if the vehicle ahead comes to a stop, the vehicle decelerates to a standstill. However, the ICC system can only apply up to 40% of the vehicle's total braking power.

This system should only be used when traffic conditions allow vehicle speeds to remain fairly constant or when vehicle speeds change gradually. If a vehicle moves into the traveling lane ahead or if a vehicle traveling ahead rapidly decelerates, the distance between vehicles may

become closer because the ICC system cannot decelerate the vehicle quickly enough. If this occurs, the ICC system sounds a warning chime and blinks the system display to notify the driver to take necessary action.

The ICC system cancels and a warning chime sounds if the speed is below approximately 15 MPH (25 km/h) and a vehicle is not detected ahead. For ProPI-LOT Assist with Navi-link equipped vehicles on a limited access freeway as identified in the navigation map data, the ICC system cancels and a warning chime sounds if your vehicle is at a standstill for more than approximately 3 seconds and a vehicle is not detected ahead.

The ICC system operates as follows:

- When there are no vehicles traveling ahead, the ICC system maintains the speed set by the driver. The vehicle set speed range is between approximately 20 and 90 MPH (30 and 144 km/h).
- When there is a vehicle traveling ahead, the ICC system adjusts the speed to maintain the distance, selected by the driver, from the vehicle ahead. If the vehicle ahead comes to a stop, the vehicle decelerates to a standstill. Once your vehicle stops,

the ICC system keeps the vehicle stopped.

- When the vehicle traveling ahead moves to a different traveling lane, the ICC system accelerates and maintains vehicle speed up to the set speed.

The ICC system does not control vehicle speed or warn you when you approach stationary and slow moving vehicles. You must pay attention to vehicle operation to maintain proper distance from vehicles ahead when approaching toll gates or traffic congestion.

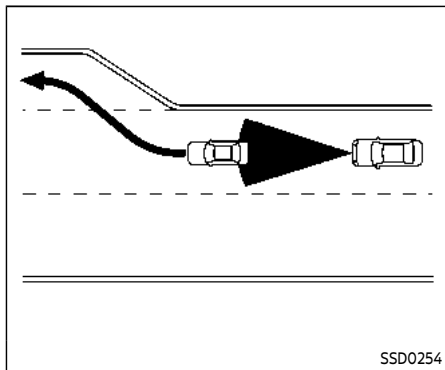

Normally when controlling the distance to a vehicle ahead, the system automatically accelerates or decelerates your vehicle according to the speed of the vehicle ahead.

Depress the accelerator to properly accelerate your vehicle when acceleration is required for a lane change. Depress the brake pedal when deceleration is required to maintain a safe distance to the vehicle ahead due to sudden braking or if a vehicle cuts in. Always stay alert when using the ICC system.

When driving on the highway at a vehicle set speed and approaching a slower traveling vehicle ahead, the ICC system adjusts the speed to maintain the distance, selected by the driver, from the vehicle ahead. If the vehicle ahead changes lanes or exits the highway, the ICC system accelerates and maintains the vehicle set speed. Pay attention to the driving operation to maintain control of the vehicle as it accelerates to the set speed.

The vehicle may not maintain the set speed on winding or hilly roads. If this occurs, you will have to manually control the vehicle speed.

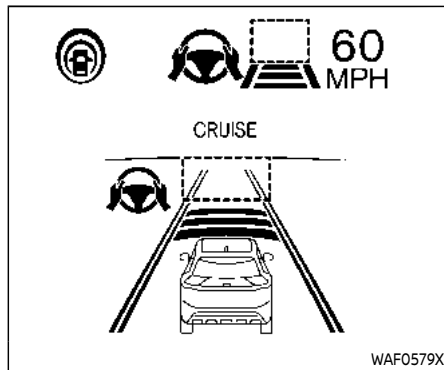

System set display — no vehicle detected ahead*

No vehicle detected ahead:

The driver sets the desired vehicle speed based on the road conditions. The ICC system maintains the vehicle set speed, similar to standard cruise control, as long as no vehicle is detected in the lane ahead. The ICC system displays the vehicle set speed.

*: The design of the set display may differ depending on the model.

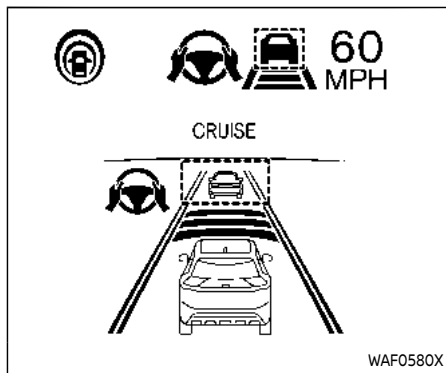

System set display — vehicle ahead*

Vehicle detected ahead:

When a vehicle is detected in the lane ahead, the ICC system decelerates the vehicle by controlling the throttle and applying the brakes to match the speed of a slower vehicle ahead. The ICC system then adjusts the vehicle speed based on the speed of the vehicle ahead to maintain the driver selected distance.

NOTE:

- The stop lights of the vehicle come on when braking is performed by the ICC system.
- When the brake is applied by the system, a noise may be heard. This is not a malfunction.

When the ICC system detects a vehicle ahead, the vehicle ahead detection indicator and the speed control status indicator (distance control mode) illuminates in green.

*: The design of the set display may differ depending on the model.

Vehicle ahead stops:

When a vehicle ahead is detected and it gradually decelerates to stop, your vehicle decelerates to a standstill. When your vehicle is at a standstill, the "(RES+) Follow Vehicle Ahead" message is displayed on the vehicle information display.

Vehicle ahead accelerates:

- When your vehicle is stopped for less than approximately 3 seconds and the vehicle ahead begins to move, your vehicle will start moving again automatically.
- When your vehicle is at a standstill for more than approximately 3 seconds and the vehicle ahead begins to accelerate, push up the RES+ switch or lightly depress the accelerator pedal. The ICC system starts to follow the vehicle ahead.
- Always check surroundings before restarting the vehicle.

- For vehicles equipped with ProPILOT Assist with Navi-link and only when on a limited access freeway (as identified in the navigation map data):
 - The time the vehicle can remain stopped and automatically restart is extended from 3 seconds to 30 seconds.
 - If a vehicle ahead cuts in or out of the lane ahead, the vehicle may not automatically start when the traffic ahead begins to move. You need to push up the RES+ switch or lightly depress the accelerator pedal to follow the vehicle directly ahead when it is safe to do so.

Vehicle ahead not detected:

When a vehicle is no longer detected ahead, the ICC system gradually accelerates your vehicle to resume the previously vehicle set speed. The ICC system then maintains the vehicle set speed.

When a vehicle is no longer detected, the vehicle ahead detection indicator and speed control status indicator (maintain speed control mode) turn off.

The ICC system gradually accelerates to the vehicle set speed, but you can depress the accelerator pedal to quickly accelerate. When a vehicle is no longer

detected and your vehicle is traveling under approximately 15 MPH (25 km/h), the ICC system automatically cancels. For ProPILOT Assist with Navi-link equipped vehicles on a limited access freeway as identified in the navigation map data, the ICC system cancels and a warning chime sounds if your vehicle is at a standstill for more than approximately 3 seconds and a vehicle is not detected ahead.

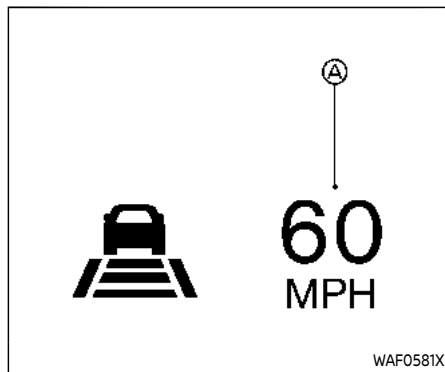

When passing another vehicle, the vehicle set speed indicator **A** flashes when the vehicle speed exceeds the set speed. The vehicle ahead detection indicator turns off when the area ahead of the vehicle is open. When the pedal is released, the vehicle returns to the previously set speed. Even though your vehicle speed is set in the ICC system, you can depress the accelerator pedal when it is necessary to accelerate your vehicle rapidly.

Cut-in detection

If a vehicle moves into your traveling lane near your vehicle, the ICC system may inform the driver by flashing the vehicle ahead detection indicator.

Approach warning

If your vehicle comes closer to the vehicle ahead due to rapid deceleration of that vehicle or if another vehicle cuts in, the system warns the driver with the chime and ICC system display. Decelerate by depressing the brake pedal to maintain a safe vehicle distance if:

- The chime sounds.
- The vehicle ahead detection indicator and set distance indicator blink.
- You judge it necessary to maintain a safe distance.

The warning chime may not sound in some cases when there is a short distance between vehicles. Some examples are:

- When the vehicles are traveling at the same speed and the distance between vehicles is not changing.
- When the vehicle ahead is traveling faster and the distance between vehicles is increasing.
- When a vehicle cuts in near your vehicle.

The warning chime will not sound when:

- Your vehicle approaches other vehicles that are parked or moving slowly.
- The accelerator pedal is depressed, overriding the system.

NOTE:

The approach warning chime may sound and the system display may flash when the radar sensor detects objects on the side of the vehicle or on the side of the road. This may cause the ICC system to decelerate or accelerate the vehicle. The radar sensor may detect these objects when the vehicle is driven on winding, narrow, or hilly roads or when the vehicle is entering or exiting a curve. In these cases, you will have to manually control the proper distance ahead of your vehicle.

Also, the sensor sensitivity can be affected by vehicle operation (steering maneuver or driving position in the lane) or traffic or vehicle conditions (for example, if a vehicle is being driven with some damage).

Acceleration when passing

When the ICC system is engaged above 44 MPH (70 km/h) and following a slower vehicle (below the vehicle set speed), and the turn signal is activated to the left, the ICC system will automatically start to accelerate the vehicle to help initiate passing on the left and will begin to reduce the distance to vehicle directly ahead. Only the left side turn signal operates this feature. As the driver steers the vehicle and moves into the passing lane, if no vehicle is detected ahead the ICC system will continue to accelerate to the vehicle set speed. If another vehicle is detected ahead, then the vehicle will accelerate up to the following speed of that vehicle. If the vehicle is not steered into the left lane to pass, the acceleration will stop after a short time and regain the set following distance. Acceleration can be stopped at any point by depressing the brake pedal or the CANCEL switch on the steering wheel.



WARNING

In order to reduce the risk of a collision that may result in serious injury or death, please be aware of the following:

- **This function is only activated with the left turn signal and will briefly accelerate the vehicle even if a lane change is not initiated. This can include non-passing situations such as left side exits.**
- **Ensure that when passing another vehicle, the adjacent lane is clear before initiating the pass. Sudden changes in traffic may occur while passing. Always manually steer or brake as needed. Never solely rely on the system.**

Speed Limit Assist - a feature of ProPILOT Assist with Navi-link (if so equipped)



WARNING

Listed below are the system limitations for the Speed Limit Assist. Failure to operate the vehicle in accordance with these system limitations could result in serious injury or death:

- **It is the driver's responsibility to select the proper speed, follow all traffic regulations and observe**

other road users.

- The Speed Limit Assist may not operate properly and the actual speed limit may not be applied to the vehicle set speed in all conditions. The driver must manually control the vehicle speed.

Below are some examples:

- When the Traffic Sign Recognition (TSR) system is not functioning properly or turned off. (See “Traffic Sign Recognition (TSR)” (P.5-44).)
- When driving in countries or areas not covered by the navigation system.
- When crossing national boundaries.
- When driving on the exit of the limited access freeway as identified in the navigation map data.
- When driving in an area with nearby parallel roads (for example, freeway with a parallel service drive).
- When driving in an area where each lane has a different speed limit sign.

- When driving on a road under construction or in a construction zone.
- When the data from the navigation system is not up-to-date or is unavailable.

When the ProPILOT Assist with Navi-link is active and it detects a change of the speed limit, the new speed limit is indicated and it can be applied to the vehicle set speed automatically or manually.

The Speed Limit Assist operates:

- When the detected speed limit is 20 MPH (30 km/h) and above.
- The “Spd. Limit Assist” is enabled in the settings menu of the vehicle information display.

NOTE:

- While the accelerator pedal is operated with AUTO mode selected, the Speed Limit Assist will function (automatically adjust the vehicle set speed) only when the detected speed limit is faster than the vehicle set speed.
- In the following situations, the Speed Limit Assist will not operate:
 - When an increase in the posted speed limit is detected, but the

vehicle set speed is already faster than the new speed limit.

- When a decrease in the posted speed limit is detected, but the vehicle set speed is already lower than the new speed limit.

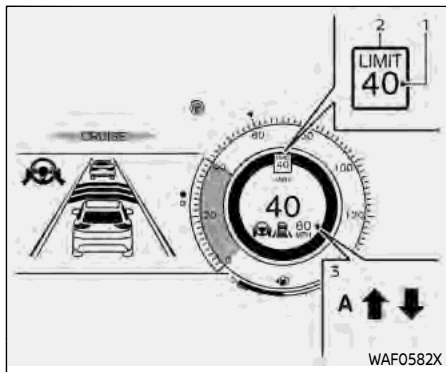

Example

System display and indicators:

1. Detected speed limit indicator
Displays the currently detected speed limit. For additional information, see "Traffic Sign Recognition (TSR)" (P.5-44).
2. Applied speed limit indicator (green frame)
Indicates the detected speed limit can be applied to the vehicle set speed.
3. Speed Limit Assist indicator
Indicates the system activation mode or system operation.
" ↑ " : Manual mode is activated and a

new speed limit (faster speed value) is indicated.

" ↓ " : Manual mode is activated and a new speed limit (lower speed value) is indicated.

"A" : Auto mode is activated.

Operating the system:

When the system detects a different speed limit, the new speed value is indicated. The vehicle set speed can be changed to the indicated speed limit automatically or manually.

When Manual mode is selected on settings menu (factory default setting):

- To accept the newly indicated speed limit, operate the RES+ switch (in case of speed limit up) or SET- switch (in case of speed limit down).
- The Speed Limit Assist indicator (↑ or ↓) will turn off after approximately 10 seconds if the RES+ or SET- switch is not operated. (The Speed Limit Assist indicator can be turned off immediately by operating the opposite switch from the direction indicated by the Speed Limit Assist indicator.)

The system will not activate if a speed limit change is not detected.

When Auto mode is selected on the settings menu:

- The indicated speed limit is applied to the vehicle set speed automatically when on a limited access freeway when identified in the navigation map data. Also, if the ProPILOT Assist with Navilink system is ON, but not set (active), and a new speed limit is detected, the vehicle set speed is automatically updated.
- The Auto mode may not be available in some regions or on roads other than limited access freeways. In this case, the system operates as the Manual mode.

NOTE:

Auto mode will not function in Hawaii or US island territories.

How to activate or deactivate the system:

1. Push the ◀ ▶ button on the steering wheel until "Settings" appears in the vehicle information display, and push the scroll dial.
2. Use the scroll dial to select "Driver Assistance". Then push the scroll dial.
3. Select "Spd. Limit Assist", and push the scroll dial to select "Auto" or "Manual" to enable (not activate) the system.

To deactivate the system, select "OFF".

NOTE:

The system will retain current settings in the vehicle information display even if the engine is restarted.

Speed Adjust by Route - a feature of ProPILOT Assist with Navi-link (if so equipped)



WARNING

Listed below are the system limitations for the Speed Adjust by Route. Failure to operate the vehicle in accordance with these system limitations could result in serious injury or death:

- There are limitations to the Speed Adjust by Route system capability. The system does not function in all driving, traffic, weather and road conditions. It is the driver's responsibility to stay alert, drive safely, and be in control of the vehicle at all times.
- The Speed Adjust by Route system does not brake the vehicle to a stop. Whenever necessary, the driver must apply appropriate braking.

- It is the driver's responsibility to select the proper speed, follow all traffic regulations and observe other road users.
- The Speed Adjust by Route system will not function in Hawaii or US island territories.
- The Speed Adjust by Route may not operate properly in some road and traffic conditions, the system may unexpectedly change the speed. The driver must manually control the vehicle speed.

Below are some examples:

- When the data from the navigation system is not up-to-date or is unavailable.
- When not driving along the route suggested by the navigation system.
- When the navigation system is recalculating the route.
- When driving in countries or areas not covered by the navigation system.
- When driving on a road under construction or newly constructed road.

- When driving near a road split or junction.
- When driving in bad weather or poor road conditions.

When the ProPILOT Assist with Navi-link is active on a limited access freeway (as identified in the navigation map data), the Speed Adjust by Route uses road information provided by the navigation system and can adjust the vehicle speed depending on curves, junctions and exits. The system may not always reduce speed for all curves, junctions or exits and the driver may need to apply additional braking at any time.

When the vehicle is through the curve or junction, the vehicle will accelerate again to the set speed. When exiting the limited access freeway, the driver will need to apply braking at the end of the exit.

NOTE:

- The system does not operate when the accelerator pedal is depressed.
- The system may not operate depending on the set distance to the vehicle ahead and vehicles detected ahead.

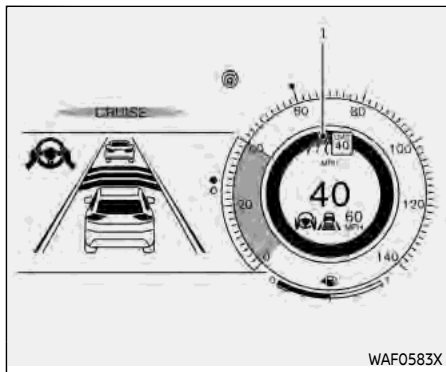

Example

System display and indicators:

1. Road information indicator

Appears when the system adjusts the speed depending on turns or exits.

	Curves and junctions
	Exits

How to activate or deactivate the system:

1. Push the ◀ ▶ button on the steering wheel until "Settings" appears in the vehicle information display, and push the scroll dial.
2. Use the scroll dial to select "Driver Assistance". Then push the scroll dial.
3. Select "Speed Adjust by Route" and push the scroll dial to turn the system on or off.

NOTE:

The system will retain current settings in the vehicle information display even if the engine is restarted.

ICC system limitations



WARNING

Listed below are the system limitations for the ICC system. Failure to operate the vehicle in accordance with these system limitations could result in serious injury or death:

- The ICC system is primarily intended for use on highways and freeways. It is not advisable to use the ICC system in city/urban traffic.

- The ICC system will not adapt automatically to road conditions. This system should be used in evenly flowing traffic. Do not use the system on roads with sharp curves or on icy roads, in heavy rain or in fog.
- As there is a performance limit to the distance control function, never rely solely on the ICC system. This system does not correct careless, inattentive or absent-minded driving or overcome poor visibility in rain, fog, or other bad weather. Decelerate the vehicle speed by depressing the brake pedal, depending on the distance to the vehicle ahead and the surrounding circumstances in order to maintain a safe distance between vehicles.
- When the ICC system automatically brings the vehicle to a stop, your vehicle can automatically accelerate if the vehicle is stopped for less than approximately 3 seconds. Be prepared to stop your vehicle if necessary.
- For vehicles equipped with ProPILOT Assist with Navi-link and only when on a limited access freeway (as identified in the navigation

map data):

- The time the vehicle can remain stopped and automatically restart is extended from 3 seconds to 30 seconds.
- If a vehicle ahead cuts in or out of the lane ahead, the vehicle may not automatically start when the traffic ahead begins to move. You need to push up the RES+ switch or lightly depress the accelerator pedal to follow the vehicle directly ahead when it is safe to do so.
- Always check surroundings before restarting the vehicle.
- Always pay attention to the operation of the vehicle and be ready to manually control the proper following distance. The ICC system may not be able to maintain the selected distance between vehicles (following distance) or selected vehicle speed under some circumstances.
- The ICC system does not detect the following objects:
 - Stationary or slow moving vehicles (when your vehicle is

approaching them)

- Pedestrians or objects in the roadway
- Oncoming vehicles in the same lane
- Motorcycles traveling offset in the travel lane
- The ICC system may not detect a vehicle ahead in certain road, weather or driving conditions. To avoid accidents, never use the ICC system under the following conditions:
 - On roads with heavy, high-speed traffic or sharp curves
 - On slippery road surfaces such as on ice or snow, etc.
 - On a bumpy road surface, such as an uneven dirt road
 - On steep downhill roads (the vehicle may go beyond the vehicle set speed and frequent braking may result in overheating the brakes)
 - On repeated uphill and downhill roads
 - During bad weather (rain, fog, snow, etc.)

- When the sensor detection is reduced (conditions such as rain, snow, fog, dust storms, sandstorms, and road spray from other vehicles)
- When dirt, ice, snow or other material adhere to the radar sensor area
- When traffic conditions make it difficult to keep a proper distance between vehicles because of frequent acceleration or deceleration
- When a complicated-shaped vehicle such as a car carrier trailer or flatbed truck/trailer is near the vehicle ahead
- When there is interference by other radar sources
- When excessively heavy baggage is loaded in the rear seat or cargo area of your vehicle
- When towing a trailer or other vehicle
- In some road or traffic conditions, a vehicle or object can unexpectedly come into the sensor detection zone and cause automatic braking. Always stay alert and

avoid using the ICC system where not recommended in this warning section.

- **The ICC system also uses a multi-sensing front camera. The following are some conditions in which the camera may not properly detect a vehicle and detection of a vehicle ahead may be delayed:**
 - **Poor visibility (conditions such as rain, snow, fog, dust storms, sandstorms, and road spray from other vehicles)**
 - **The camera area of the windshield is fogged up or covered with dirt, water drops, ice, snow, etc.**
 - **Strong light (for example, sunlight or high beams from oncoming vehicles) enters the front camera**
 - **A sudden change in brightness occurs (for example, when the vehicle enters or exits a tunnel or shaded area or lightning flashes)**

The ICC system is designed to automatically check the radar sensor's operation within the limitations of the system

The detection zone of the radar sensor is limited. A vehicle ahead must be in the detection zone for the ICC system to maintain the selected distance from the vehicle ahead. A vehicle ahead may move outside of the detection zone due to its position within the same lane of travel. Motorcycles may not be detected in the same lane ahead if they are traveling offset from the center line of the lane. A vehicle that is entering the lane ahead may not be detected until the vehicle has completely moved into the lane.

If this occurs, the ICC system may warn you by blinking the system indicator and sounding the chime. The driver may have to manually control the proper distance away from the vehicle traveling ahead.

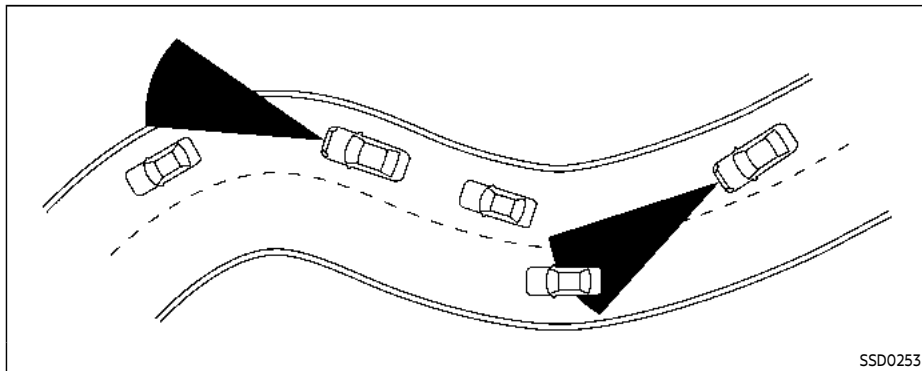
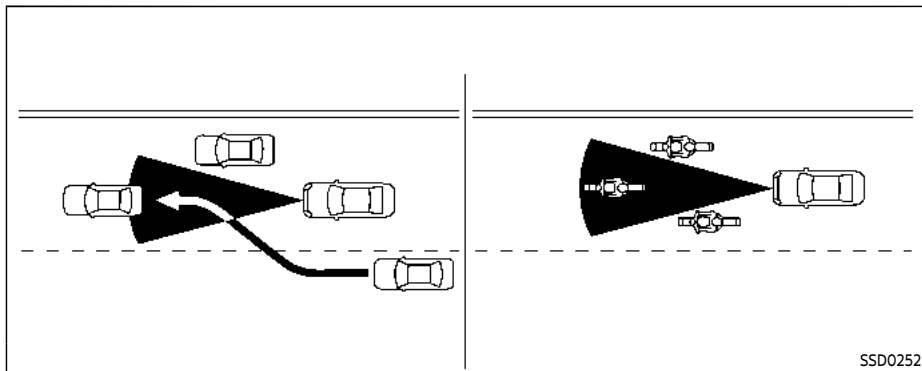

When driving on some roads, such as winding, hilly, curved, narrow roads, or roads which are under construction, the radar sensor may detect vehicles in a different lane, or may temporarily not detect a vehicle traveling ahead. This may cause the ICC system to decelerate or accelerate the vehicle.

The detection of vehicles may also be affected by vehicle operation (steering maneuver or traveling position in the lane, etc.) or vehicle condition.

If this occurs, the ICC system may warn you by blinking the system indicator and sounding the chime unexpectedly. You will have to manually control the proper distance away from the vehicle traveling ahead.

ICC system temporarily unavailable

The following are conditions in which the ICC system may be temporarily unavailable. In these instances, the ICC system may not cancel and may not be able to maintain the selected following distance from the vehicle ahead.

Condition A:

Under the following conditions, the ICC system is automatically canceled. A chime will sound and the system will not be able to be set:

- Any door is open.
- The driver's seat belt is unfastened.
- The vehicle ahead is not detected and your vehicle is traveling below the speed of 15 MPH (25 km/h). For ProPILOT Assist with Navi-link equipped vehicles on a limited access freeway as identified in the navigation map data, the ICC system cancels and a warning chime sounds if your vehicle is at a standstill for more than approximately 3 seconds and a vehicle is not detected ahead.
- Your vehicle has been stopped by the ICC system for approximately 3 minutes or longer.
- The shift lever is moved out of the D (Drive) position or into the manual shift mode.
- The electronic parking brake is applied.
- The VDC system is turned off.
- The AEB applies harder braking
- VDC (including the traction control system) operates.
- The SNOW mode or OFF-ROAD mode is selected (AWD models).
- A wheel slips.
- When the front radar is impaired due to dirt or an other obstruction blocking the radar sensor.

- When the radar signal is temporarily interrupted.

Action to take:

When the conditions listed above are no longer present, turn the system off using the ProPILOT Assist switch. Turn the ProPILOT Assist system back on to use the system.

NOTE:

When the ICC system is canceled under any of the following conditions at a standstill, the electronic parking brake is automatically activated:

- **Any door is open.**
- **The driver's seat belt is unfastened.**
- **Your vehicle has been stopped by the ICC system for approximately 3 minutes or longer.**
- **The shift lever is moved out of the D (Drive) position or into the manual shift mode.**
- **The VDC system is turned off.**
- **When the front radar is impaired due to dirt or an other obstruction blocking the radar sensor.**
- **When the radar signal is temporarily interrupted.**

Condition B:

When there is inclement weather (rain, fog, snow, etc.) blocking the front radar

sensor, the ICC system will automatically be canceled, the chime will sound and the "Forward Driving Aids temporarily disabled Front Sensor blocked" warning message will appear in the vehicle information display.

Action to take:

When the above condition is no longer present, the warning message will no longer be available in the vehicle information display and the system will operate normally. If the warning message continues to appear, have the system checked. It is recommended that you visit a NISSAN dealer for this service.

Condition C:

When the radar sensor on the front of the vehicle is covered with dirt or is obstructed, the ICC system will automatically be canceled.

The chime will sound and the "Forward Driving Aids temporarily disabled Front Sensor blocked" warning message will appear in the vehicle information display.

Action to take:

If the warning message appears, stop the vehicle in a safe place, push the park button to engage the P (Park) position, and turn the engine off. When the radar signal is temporarily interrupted, clean the sensor area and restart the engine. If

the warning message continues to appear, have the system checked. It is recommended that you visit a NISSAN dealer for this service.

Condition D:

When driving on roads with limited road structures or buildings (for example, long bridges, deserts, snow fields, driving next to long walls), the system may display the "Forward Driving Aids temporarily disabled Front Sensor blocked" message.

Action to take:

When the above driving conditions no longer exist, turn the system back on.

ICC system malfunction

If the ICC system malfunctions, it will be turned off automatically, a chime will sound, and the speed control status warning (orange) will illuminate.

Action to take:

If the warning illuminates, stop the vehicle in a safe place. Turn the engine off, restart the engine and set the ICC system again. If it is not possible to set the ICC system or the warning stays on, it may be a malfunction. Although the normal driving can be continued, the ICC system should be inspected. It is recommended that you visit a NISSAN dealer for this service.

NOTE:

If the ICC system is temporarily unavailable, the conventional cruise control mode may still be used. For additional information, see "Conventional (fixed speed) cruise control mode" (P.5-119).

ICC sensor maintenance

The radar sensor is located on the front of the vehicle.

To keep the ICC system operating properly, be sure to observe the following:

- Always keep the sensor area clean.
- Do not strike or damage the areas around the sensor.
- Do not attach a sticker (including transparent material) or install an accessory near the sensor. This could cause failure or malfunction.
- Do not attach metallic objects near the sensor area (brush guard, etc.). This could cause failure or malfunction.
- Do not alter, remove, or paint the front bumper.

Before customizing or restoring the front bumper, it is recommended that you visit a NISSAN dealer.

The camera sensor is located above the inside mirror.

To keep the proper operation of the

systems and prevent a system malfunction, be sure to observe the following:

- Always keep the windshield clean.
- Do not attach a sticker (including transparent material) or install an accessory near the camera unit.
- Do not place reflective materials, such as white paper or a mirror, on the instrument panel. The reflection of sunlight may adversely affect the camera unit's capability of detecting the lane markers.
- Do not strike or damage the areas around the camera unit. Do not touch the camera lens or remove the screw located on the camera unit.

If the camera unit is damaged due to an accident, it is recommended that you visit a NISSAN dealer.

For additional information, see "Common troubleshooting guide" (P.5-40).

Radio frequency statement:

For USA

Type approval number:

FCC ID: NF3-FR5CPEC

User Manual statement according to §15.19:

This device complies with Part 15 of the FCC Rules.

Operation is subject to the following two conditions:

1. this device may not cause harmful interference, and
2. this device must accept any interference received, including interference that may cause undesired operation.

User Manual statement according to §15.21:

Changes or modifications made to this equipment not expressly approved by Robert BOSCH GmbH may void the FCC authorization to operate this equipment.

User Manual statement according to §15.105:

This equipment has been tested and found to comply with the limits for a Class A digital device, pursuant to Part 15 of the FCC Rules. These limits are designed to provide reasonable protection against harmful interference when the equipment is operated in a commercial environment. This equipment generates, uses, and can radiate radio frequency energy and, if not installed and used in accordance with the instruction manual, may cause harmful interference to radio communications. Operation of this equipment in a residential area is likely to cause harmful interference in which case the user will be required to correct the inter-

ference at his own expense.

RF Exposure Information according 2.1091/2.1093/OET bulletin 65:

Radiofrequency radiation exposure information:

This equipment complies with FCC radiation exposure limits set forth for an uncontrolled environment. This equipment should be installed and operated with minimum distance of 20 cm between the radiator and your body.

The transmitter must not be co-located or operating in conjunction with any other antenna or transmitter.

For Canada

Type approval number:

IC: 3387A-FR5CPEC

Legal warning for RF equipment:

This device complies with Industry Canada licence-exempt RSS standard(s). Operation is subject to the following two conditions: (1) this device may not cause interference, and (2) this device must accept any interference, including interference that may cause undesired operation of the device.

STEERING ASSIST



WARNING

Failure to follow the warnings and instructions for proper use of the Steering Assist could result in serious injury or death.

- **The Steering Assist is not a replacement for proper driving procedures and is not designed to correct careless, inattentive or absent-minded driving. The Steering Assist will not always steer the vehicle to keep it in the lane. It is not designed to prevent loss of control. It is the driver's responsibility to stay alert, drive safely, keep the vehicle in the traveling lane, and be in control of the vehicle at all times.**
- **As there is a performance limit to the Steering Assist's capability, never rely solely on the system. The Steering Assist does not function in all driving, traffic, weather, and road conditions. Always drive safely, pay attention to the operation of the vehicle, and manually control your vehicle appropriately.**

- **The Steering Assist is intended for use on well-developed highways with gentle (moderate) curves. To avoid risk of an accident, do not use this system on local or non-highway roads.**
- **The Steering Assist only steers the vehicle to maintain its position in the center of a lane. The vehicle will not steer to avoid objects in the road in front of the vehicle or to avoid a vehicle moving into your lane.**
- **It is the driver's responsibility to stay alert, drive safely, keep the vehicle in the traveling lane, and be in control of the vehicle at all times. Never take your hands off the steering wheel when driving. Always keep your hands on the steering wheel and drive your vehicle safely.**
- **Always drive carefully and attentively when using the Steering Assist. Read and understand the Owner's Manual thoroughly before using the Steering Assist. To avoid serious injury or death, do not rely on the system to prevent accidents or to control the vehicle's speed in emergency situations. Do not use the Steering**

Assist except in appropriate road and traffic conditions.

Steering Assist operation

Steering Assist helps the driver keep the vehicle near the center of the lane when both right and left lane markers are detected. Steering Assist only operates when combined with the Intelligent Cruise Control (ICC) system. For additional information, see "Intelligent Cruise Control (ICC)" (P.5-98).

The Steering Assist can be activated when the following conditions are met:

- The ICC system is activated.
- Lane markers on both sides are clearly detected.
- A vehicle ahead is detected (when the vehicle is driven at speeds under 37 MPH (60 km/h)).
- The driver grips the steering wheel.
- The vehicle is driven at the center of the lane.
- The turn signals are not operated.
- The windshield wiper is not operated in the high speed position (the Steering Assist function is disabled after the wiper operates for approximately 10 seconds in the high speed position).

To enable or disable the Steering Assist,

see "How to enable/disable the Steering Assist" (P.5-97).

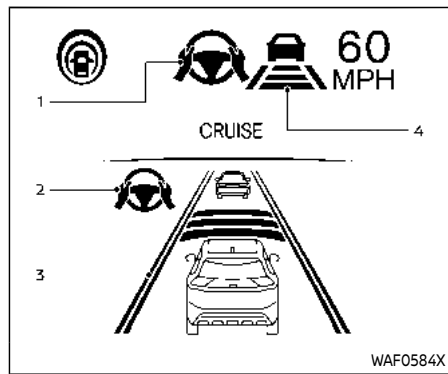

Example

Steering Assist display and indicators

1. Steering Assist status indicator/warning

Displays the status of the Steering Assist by the color of the indicator/warning

- Steering Assist status indicator (gray): Steering Assist standby
- Steering Assist status indicator (green): Steering Assist active
- Steering Assist status indicator (orange): Steering Assist malfunction

2. Steering Assist indicator

Indicates the status of the Steering Assist by the color of the indicator

- Steering Assist indicator (gray): Steering Assist standby
- Steering Assist indicator (green): Steering Assist active

3. Lane marker indicator

Indicates whether the system detects the lane marker

- Lane marker indicator (gray): Lane markers not detected
- Lane marker indicator (green): Lane markers detected
- Lane marker indicator (orange): Lane departure is detected

4. Lane marker indicator/speed control status indicator/set distance indicator

Displays the status of the Steering Assist by the color of the lane marker indicator.

- Lane marker indicator (gray): Steering Assist standby
- Lane marker indicator (green): Steering Assist active

For the speed control status indicator and set distance indicator, see "ProPILOT Assist system display and indicators" (P.5-90).

When the Steering Assist is in operation, the Steering Assist status indicator ①, the Steering Assist indicator ②, and the lane marker indicator ③ and ④ on the vehicle information display turn green. A chime sounds when the Steering Assist initially activates.

When the Steering Assist deactivates, the Steering Assist status indicator ①, the Steering Assist indicator ②, and the lane marker indicator ③ and ④ on the vehicle information display turn gray and a chime sounds twice.

Intelligent Lane Intervention (I-LI)

With the Steering Assist active, when a curve or strong cross wind exceeds the capabilities of the system and your vehicle approaches either the left or the right side of the traveling lane, the I-LI system will flash the I-LI indicator on the vehicle information display and provide steering wheel vibration to alert the driver. The warning chime will also sound (4 rapid beeps). Then, the I-LI system automatically applies the brakes for a short period of time to help assist the driver to return the vehicle to the center of the traveling lane. This action is in addition to any Steering Assist actions and the warnings cannot be turned off. For more information, see "Intelligent Lane Intervention (I-LI)" (P.5-52).

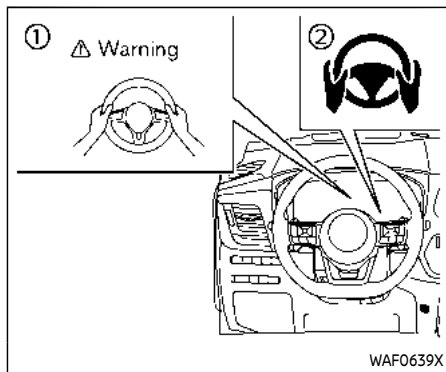

Hands on detection

When the Steering Assist is activated, it monitors the driver's steering wheel operation.

If the steering wheel is not operated or the driver takes his/her hands off the steering wheel for a period of time, the warning ① appears in the vehicle information display and the hands OFF warning light ② illuminates.

If the driver does not operate the steering wheel after the warning has been displayed and the warning light illuminated, an audible alert sounds and both the warning and the warning light flash. If the driver still does not operate the steering

wheel, the system applies a momentary brake application to request the driver to take control of the vehicle again.

If the driver still does not respond, the system turns on the hazard flasher and slows the vehicle to a complete stop.

The driver can cancel the deceleration at any time by steering, braking, accelerating, or operating the ProPILOT Assist switch.

WARNING

Steering Assist is not a system for a hands-free driving. Always keep your hands on the steering wheel and drive your vehicle safely. Failure to do so could cause a collision resulting in serious personal injury or death.

NOTE:

If the driver lightly touches (instead of firmly grips) the steering wheel, the steering torque sensor may not detect the driver's hand(s) on the steering wheel and a sequence of warnings may occur. When the driver holds and operates the steering wheel again, the warnings turn off.

Steering Assist limitations

WARNING

- **In the following situations, the camera may not detect lane markers correctly or may detect lane markers incorrectly and the Steering Assist may not operate properly:**
 - When driving on roads where there are multiple parallel lane markers, lane markers that are faded or not painted clearly, non-standard lane markers, or lane markers covered with water, dirt, snow, etc.
 - When driving on roads with discontinued lane markers
 - When driving on roads with a widening or narrowing lane width
 - When driving on roads where there are multiple lanes or unclear lane markers due to road construction
 - When driving on roads where there are sharply contrasting objects, such as shadows,

snow, water, wheel ruts, seams, or lines remaining after road repairs (the Steering Assist could detect these items as lane markers)

- When driving on roads where the traveling lane merges or separates
- Do not use the Steering Assist under the following conditions because the system may not properly detect lane markers. Doing so could cause a loss of vehicle control and result in an accident.
 - During bad weather (rain, fog, snow, dust, etc.)
 - When rain, snow, sand, etc., is thrown up by the wheels of other vehicles
 - When dirt, oil, ice, snow, water, or another object adheres to the camera unit
 - When the lens of the camera unit is foggy
 - When strong light (for example, sunlight or high beams from oncoming vehicles) shines on the camera

– When the headlights are not bright due to dirt on the lens or the headlights are off in tunnels or darkness

- When a sudden change in brightness occurs (for example, when the vehicle enters or exits a tunnel or is under a bridge)
- When driving on roads where the traveling lane merges or separates or where there are temporary lane markers because of road construction
- When there is a lane closure due to road repairs
- When driving on a bumpy road surface, such as an uneven dirt road
- When driving on sharp curves or winding roads
- When driving on repeated uphill and downhill roads
- Do not use the Steering Assist under the following conditions because the system will not operate properly:
 - When driving with a tire that is not within normal tire condi-

tions (for example, tire wear, abnormal tire pressure, installation of a spare tire, tire chains, non-standard wheels)

- When the vehicle is equipped with non-original brake or suspension parts
- When an object such as a sticker or cargo obstructs the camera
- When excessively heavy baggage is loaded in the rear seat or luggage area of your vehicle
- When the vehicle load capacity is exceeded
- When towing a trailer or other vehicle
- Excessive noise will interfere with the warning chime sound, and the beep may not be heard.
- For the ProPILOT Assist system to operate properly, the windshield in front of the camera must be clean. Replace worn wiper blades. The correct size wiper blades must be used to help make sure the windshield is kept clean. Only use Genuine NISSAN wiper blades, or equivalent wiper blades, that

are specifically designed for use on your vehicle model and model year. It is recommended that you visit your NISSAN dealer for the correct parts for your vehicle.

Steering Assist temporary standby Automatic standby due to driving operation:

When the driver activates the turn signal, the Steering Assist is temporarily placed in a standby mode. (The Steering Assist restarts automatically when the operating conditions are met again.)

Automatic standby:

In the following cases, "Not Available Front Camera Obstructed" warning message appears in the vehicle information display, along with the chime, and the Steering Assist is placed in a temporary standby mode. (The Steering Assist restarts automatically when the operating conditions are met again.)

- When lane markers on both sides are no longer detected
- When a vehicle ahead is no longer detected under approximately 37 MPH (60 km/h)

NOTE:

For ProPILOT Assist with Navi-link equipped vehicles on a limited access freeway as identified in the navigation map data, the Steering Assist system may continue to operate with visible lane markers on the both sides, even when the vehicle speed is below approximately 37 MPH (60 km/h) and a vehicle is not detected ahead.

Steering Assist cancel

Under the following conditions, the Steering Assist cancels, and the Steering Assist status indicator and the Steering Assist indicator turn off:

- When unusual lane markers appear in the traveling lane or when the lane marker cannot be correctly detected for some time due to certain conditions (for example, a snow rut, the reflection of light on a rainy day, the presence of several unclear lane markers)
- When the windshield wiper operates in the high speed operation (the Steering Assist is disabled when the wiper operates for more than approximately 10 seconds)

Action to take:

Turn the ICC system off using the CANCEL switch. When the conditions listed above are no longer present, turn the ICC system on again.

Steering Assist malfunction

When the system malfunctions, it turns off automatically. The Steering Assist status warning (orange) illuminates. A chime may sound depending on the situation.

Action to take:

Stop the vehicle in a safe location, push the park button to shift to the P (Park) position, turn the engine off, restart the engine, resume driving, and set the ICC system again. If the warning (orange) continues to illuminate, the Steering Assist is malfunctioning. Although the vehicle is still drivable under normal conditions, have the system checked. It is recommended that you visit a NISSAN dealer for this service.

Steering Assist maintenance

The camera is located above the inside mirror.

To keep the proper operation of the system and prevent a system malfunction, be sure to observe the following:

- Always keep the windshield clean.
- Do not attach a sticker (including transparent material) or install an accessory near the camera unit.
- Do not place reflective materials, such as white paper or a mirror, on the instrument panel. The reflection of sunlight may adversely affect the camera unit's capability of detecting the lane markers.
- Do not strike or damage the areas around the camera unit. Do not touch the camera lens or remove the screw located on the camera unit.

If the camera unit is damaged due to an accident, it is recommended that you visit a NISSAN dealer.

For additional information, see "Common troubleshooting guide" (P.5-40).

CONVENTIONAL (fixed speed) CRUISE CONTROL MODE

NOTE:

ProPILOT Assist provides no approach warnings, automatic braking, or Steering Assist in the conventional (fixed speed) cruise control mode.

This mode allows driving at a speed between 20 to 90 MPH (30 to 144 km/h) without keeping your foot on the accelerator pedal.



WARNING

- **In the conventional (fixed speed) cruise control mode, a warning chime does not sound to warn you if you are too close to the vehicle ahead, as neither the presence of the vehicle ahead nor the vehicle-to-vehicle distance is detected.**
- **Pay special attention to the distance between your vehicle and the vehicle ahead of you or a collision could occur.**
- **Always confirm the setting in the ICC system display.**
- **Do not use the conventional (fixed speed) cruise control mode when driving under the following conditions:**
 - When it is not possible to keep the vehicle at a set speed
 - In heavy traffic or in traffic that varies in speed
 - On winding or hilly roads
 - On slippery roads (rain, snow, ice, etc.)

– In very windy areas

- **Doing so could cause a loss of vehicle control and result in an accident.**

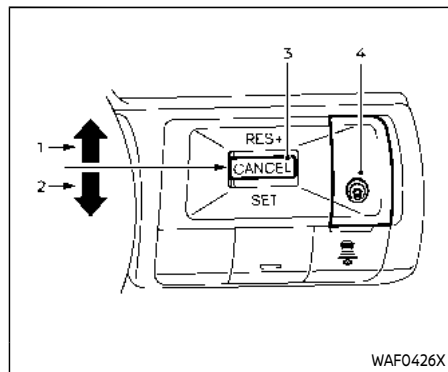

Conventional (fixed speed) cruise control switches

1. RES+ switch:
Resumes vehicle set speed or increases speed incrementally
2. SET- switch:
Sets desired cruise speed or reduces speed incrementally
3. CANCEL switch:
Deactivates the system without erasing the vehicle set speed
4. ProPILOT Assist switch:
Turns the ProPILOT Assist system on or off

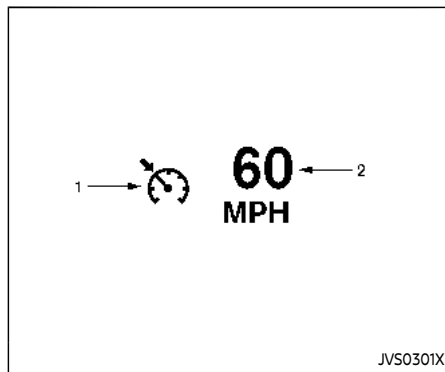

Conventional (fixed speed) cruise control mode display and indicators

The display is located in the vehicle information display.

1. Cruise indicator:
This indicator indicates the condition of the ICC system depending on a color.
 - Cruise control ON indicator (gray):
Indicates that the ProPILOT Assist switch is on
 - Cruise control SET indicator (green):
Indicates that the cruising speed is set

- Cruise control warning (orange):
Indicates that there is a malfunction in the ICC system
2. Vehicle set speed indicator:
This indicator indicates the vehicle set speed.
For Canadian models, the speed is displayed in km/h.

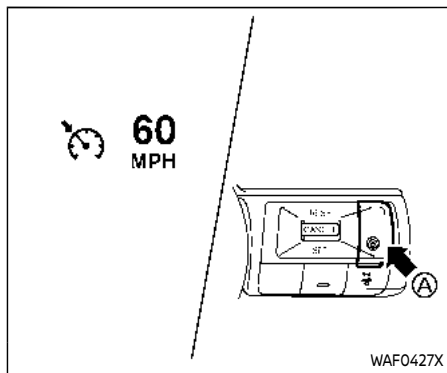

Operating conventional (fixed speed) cruise control mode

To turn on the conventional (fixed speed) cruise control mode, push and hold the ProPILOT Assist switch (A) for longer than about 1.5 seconds.

When pushing the ProPILOT Assist switch on, the conventional (fixed speed) cruise control mode display and indicators are displayed in the vehicle information display. After you hold the ProPILOT Assist switch on for longer than about 1.5 seconds, the ICC system display turns off. The cruise indicator appears. You can now set your desired cruising speed. Pushing the ProPILOT Assist switch again

will turn the system completely off. When the ignition switch is placed in the OFF position, the system is also automatically turned off.

To use the ICC system again, quickly push and release the ProPILOT Assist switch (vehicle-to-vehicle distance control mode) or push and hold it (conventional cruise control mode) again to turn it on.

WARNING

To avoid accidentally engaging cruise control, make sure to turn the ProPILOT Assist switch off when not using the ICC system.

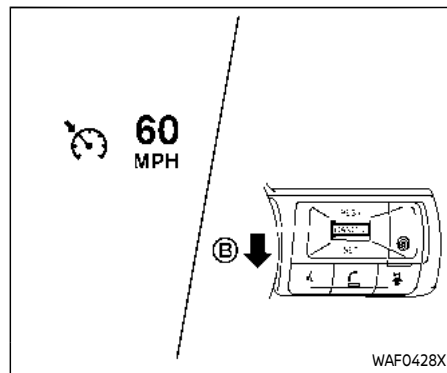

To set cruising speed, accelerate your vehicle to the desired speed, push down the SET- (B) switch and release it. (The color of the cruise indicator changes to green and vehicle set speed indicator comes on.) Take your foot off the accelerator pedal. Your vehicle will maintain the set speed.

- To pass another vehicle, depress the accelerator pedal. When you release the pedal, the vehicle will return to the previously set speed.
- The vehicle may not maintain the set speed when going up or down steep hills. If this happens, manually maintain vehicle speed.

To cancel the preset vehicle speed, use any of the following methods:

1. Push the CANCEL switch. The vehicle set speed indicator will turn off.
2. Tap the brake pedal. The vehicle set speed indicator will turn off.
3. Turn the ProPILOT Assist switch off. Both the cruise indicator and vehicle set speed indicator will turn off.

To reset at a faster cruising speed, use one of the following three methods:

1. Depress the accelerator pedal. When the vehicle attains the desired speed, push down and release the SET-switch.
2. Push up and hold the RES+ switch. When the vehicle attains the desired speed, release the switch.
3. Push up, then quickly release the RES+ switch. Each time you do this, the vehicle set speed will increase by about 1 MPH (1 km/h).

To reset at a slower cruising speed, use one of the following three methods:

1. Lightly tap the brake pedal. When the vehicle attains the desired speed, push down the SET- switch and release it.
2. Push down and hold the SET- switch. Release the switch when the vehicle

slows down to the desired speed.

3. Push down, then quickly release the SET- switch. Each time you do this, the vehicle set speed will decrease by about 1 MPH (1 km/h).

To resume the preset vehicle speed, push up and release the RES+ switch. The vehicle will resume the last set cruising speed when the vehicle speed is over 20 MPH (30 km/h).

AUTOMATIC EMERGENCY BRAKING (AEB) WITH PEDESTRIAN DETECTION SYSTEM



WARNING

Failure to follow the warnings and instructions for proper use of the AEB with Pedestrian Detection system could result in serious injury or death.

- **The AEB with Pedestrian Detection system is a supplemental aid to the driver. It is not a replacement for the driver's attention to traffic conditions or responsibility to drive safely. It cannot prevent accidents due to carelessness or dangerous driving techniques.**
- **The AEB with Pedestrian Detection system does not function in all driving, traffic, weather and road conditions.**

The AEB with Pedestrian Detection system can assist the driver when there is a risk of a forward collision with

- a vehicle ahead in the travelling lane
- a pedestrian ahead in the travelling lane
- a cyclist ahead in the travelling lane

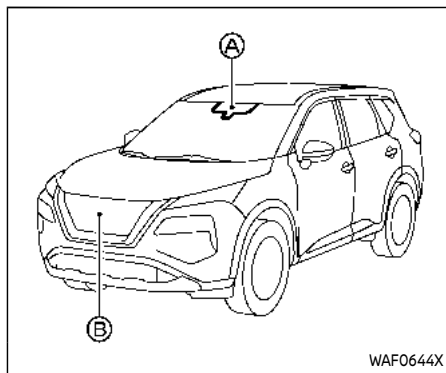

WAF0644X

The AEB with Pedestrian Detection system uses a radar sensor **B** located on the front of the vehicle to measure the distance to the vehicle ahead in the same lane.

For pedestrians and cyclists, the AEB system uses a camera **A** installed behind the windshield in addition to the radar sensor.

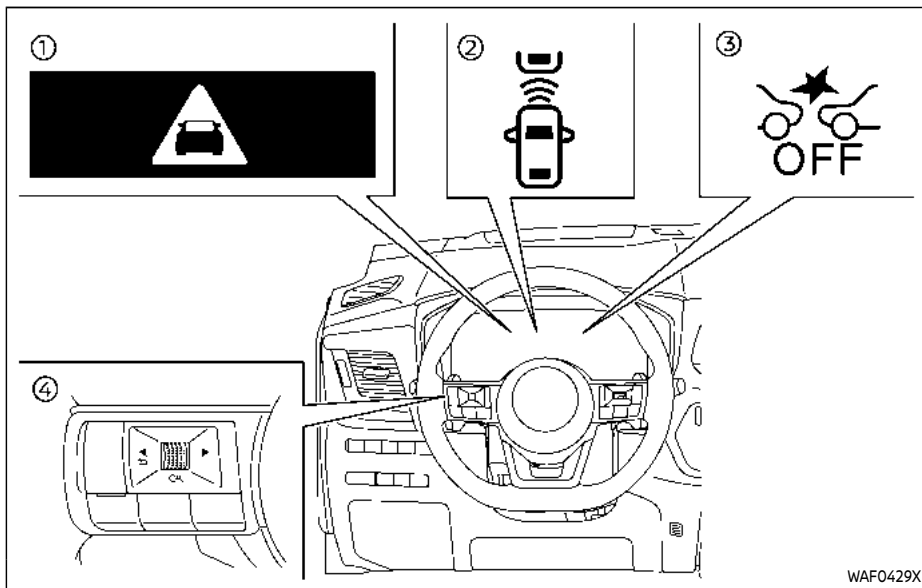

WAF0429X

- ① AEB emergency warning indicator
- ② Vehicle ahead detection indicator (on the vehicle information display)
- ③ AEB system OFF warning light (on the meter panel)
- ④ Steering-wheel-mounted controls (left side)

AEB WITH PEDESTRIAN DETECTION SYSTEM OPERATION

The AEB with Pedestrian Detection system will function when your vehicle is driven at speeds above approximately 3 MPH (5 km/h).

For the pedestrian and cyclists detection

function, the AEB with Pedestrian Detection system operates at speeds between 6 – 37 MPH (10 – 60 km/h).

If a risk of a forward collision is detected, the AEB with Pedestrian Detection system will firstly provide the warning to the driver by flashing the vehicle ahead detection indicator (yellow) in the vehicle information display and providing an audible alert. In addition, the system applies partial braking.

If the driver applies the brakes quickly and forcefully after the warning, and the AEB with Pedestrian Detection system detects that there is still the possibility of a forward collision, the system will automatically increase the braking force.

If the driver does not take action, the AEB with Pedestrian Detection system issues the second visual (flashing) (red) and audible warning. Then the system applies partial braking.

If the risk of a collision becomes imminent, the AEB with Pedestrian Detection system applies harder braking automatically.

While the AEB with Pedestrian Detection system is operating, you may hear the sound of brake operation. This is normal and indicates that the AEB with Pedestrian Detection system is operating prop-

erly.

NOTE:

The vehicle's stop lights come on when braking is performed by the AEB with Pedestrian Detection system.

Depending on vehicle speed and distance to the vehicle, pedestrian or cyclists ahead, as well as driving and roadway conditions, the system may help the driver avoid a forward collision or may help mitigate the consequences of a collision should one be unavoidable.

If the driver is handling the steering wheel, accelerating or braking, the AEB with Pedestrian Detection system will function later or will not function.

The automatic braking will cease under the following conditions:

- When the steering wheel is turned as far as necessary to avoid a collision.
- When the accelerator pedal is depressed.
- When there is no longer a vehicle, pedestrian detected ahead.

If the AEB with Pedestrian Detection system has stopped the vehicle, the vehicle will remain at a standstill for approximately 2 seconds before the brakes are released.

When the brake pedal is depressed while

the brake is applied by the system, you may feel the pedal effort is changed and may hear a sound and vibration noise. This is normal and does not indicate a malfunction. In addition, the braking force can be increased by adding the pedal effort.

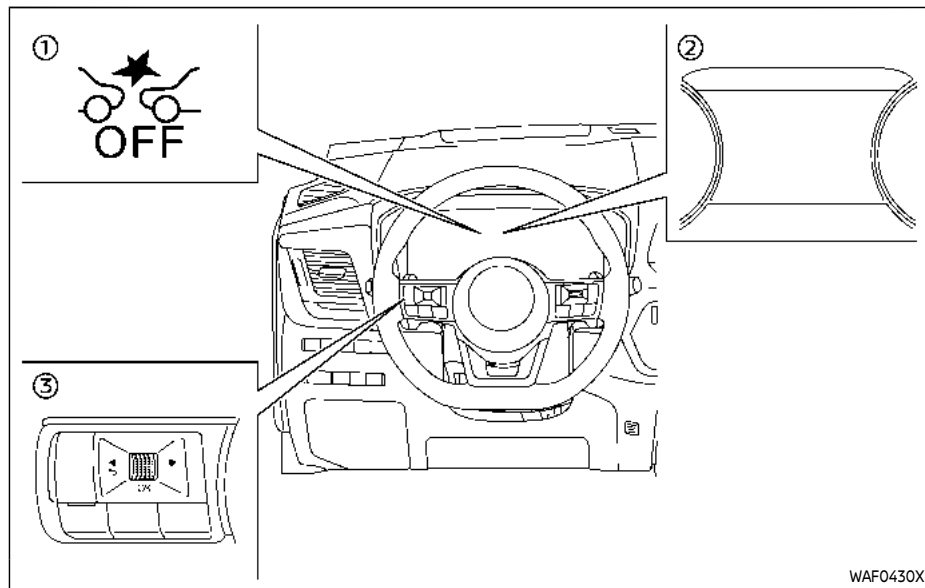

- ① AEB system OFF warning light (on the meter panel)
- ② Vehicle information display
- ③ Steering-wheel-mounted controls (left side)

TURNING THE AEB WITH PEDESTRIAN DETECTION SYSTEM ON/OFF

Perform the following steps to turn the AEB with Pedestrian Detection system on or off.

1. Push the ◀ ▶ button until "Settings" appears in the vehicle informa-

tion display and then push the scroll dial. Use the scroll dial to select "Driver Assistance." Then push the scroll dial.

2. Select "Emergency Assist" and push the scroll dial.
3. Select "Emergency Braking" and use the scroll dial to turn the system on or off.

When the AEB with Pedestrian Detection system is turned off, the AEB system OFF warning light illuminates.

NOTE:

- The AEB with Pedestrian Detection system will be automatically turned ON when the engine is restarted.
- The Intelligent Forward Collision Warning (I-FCW) system is integrated into the AEB system. There is not a separate selection for the I-FCW system. When the AEB with Pedestrian Detection system is turned off, the I-FCW system is also turned off.

AEB WITH PEDESTRIAN DETECTION SYSTEM LIMITATIONS

WARNING

Listed below are the system limitations for the AEB with Pedestrian Detection system. Failure to operate the vehicle in accordance with these system limitations could result in serious injury or death.

- The AEB with Pedestrian Detection system cannot detect all vehicles, pedestrians or cyclists under all conditions.
- The AEB with Pedestrian Detection system does not detect the following:
 - Pedestrians that are small (for example, children), in a sitting position, operating toys/skateboards, on scooters or in wheelchairs, or not in an upright standing or walking position.
 - Animals of any size.
 - Obstacles (for example, cargo or debris) on the roadway or roadside.

- Oncoming or crossing vehicles.
- Vehicles where the tires are difficult to see or the shape of the rear of the vehicle is unclear or obstructed.

– Parked vehicles.

- The AEB with Pedestrian Detection system has some performance limitations.
 - If a stationary vehicle is in the vehicle's path, the system will not function when the vehicle approaches the stationary vehicle at speeds over approximately 50 MPH (80 km/h).
 - Pedestrian and cyclist detection will not function when the vehicle is driven at speeds over approximately 37 MPH (60 km/h) or below approximately 6 MPH (10 km/h).
- For pedestrians, the AEB with Pedestrian Detection system will not issue the first warning.
- The AEB with Pedestrian Detection system may not function properly or detect a vehicle, pedestrian or cyclist ahead in the following conditions:

– In poor visibility conditions (such as rain, snow, fog, dust storms, sand storms, smoke, and road spray from other vehicles).

– If dirt, ice, snow, fog or other material is covering the radar sensor area or camera area of the windshield.

– If strong light (for example, sunlight or high beams) enters the front camera or a sudden change in brightness occurs (for example, entering a tunnel or driving in lighting).

– In dark or dimly lit conditions, such as at night or in tunnels, including cases where your vehicle's headlights are off or dim, or the tail lights of the vehicle ahead are off.

– When the direction of the camera is misaligned.

– When driving on a steep downhill slope, on roads with sharp curves, and/or bumpy or dirt roads.

- If there is interference by other radar sources.
- When your vehicle's position or movement is changed quickly or significantly (for example, lane change, turning vehicle, abrupt steering, sudden acceleration or deceleration).
- When your vehicle or the vehicle, pedestrian or cyclist ahead moves quickly or significantly such that the system cannot detect and react in time (for example, pedestrian moving quickly toward the vehicle at close range, vehicle cutting in, changing lanes, making a turn, steering abruptly, sudden acceleration or deceleration).
- When the vehicle, pedestrian or cyclist is offset from the vehicle's forward path.
- If the speed difference between the two vehicles is small.
- The pedestrian's profile is partially obscured or unidentifiable; for example, due to

- transporting luggage, pushing a stroller, wearing bulky or very loose-fitting clothing or accessories, or being in a unique posture (such as raising hands).
- There is poor contrast of a person to the background, such as having clothing color or pattern which is similar to the background.
- For approximately 15 seconds after starting the engine
- If the vehicle ahead has a unique or unusual shape, extremely low or high clearance heights, or unusual cargo loading or is narrow (for example, a motorcycle).
- When the vehicle, pedestrian or cyclist is located near a traffic sign, a reflective area (for example, water on road), or is in a shadow.
- When multiple pedestrians or cyclists are grouped together.
- When the view of the pedestrian or cyclist is obscured by a vehicle or other object.

- While towing a trailer or other vehicle.
- The system performance may be degraded in the following conditions:
 - The vehicle is driven on a slippery road.
 - The vehicle is driven on a slope.
 - Excessively heavy baggage is loaded in the rear seat or the cargo area of your vehicle.
- The system is designed to automatically check the sensor (radar and camera)'s functionality, with certain limitations. The system may not detect some forms of obstruction of the sensor area such as ice, snow or stickers, for example. In these cases, the system may not be able to warn the driver properly. Be sure that you check, clean and clear sensor areas regularly.
- In some road and traffic conditions, the AEB with Pedestrian Detection system may unexpectedly apply partial braking. When acceleration is necessary, depress the accelerator pedal to

override the system.

- The AEB with Pedestrian Detection system may operate when a pattern, object, shadow or lights are detected that are similar to the outline of vehicles, pedestrians or cyclists, or if they are the same size and position as a vehicle or motorcycle's tail lights.
- The system may keep operating when the vehicle ahead is turning right or left.
- The system may operate when your vehicle is approaching and passing a vehicle ahead.
- Depending on the road shape (curved road, entrance and exit of the curve, winding road, lane regulation, under construction, etc.), the system may operate temporarily for the oncoming vehicle in front of your vehicle.

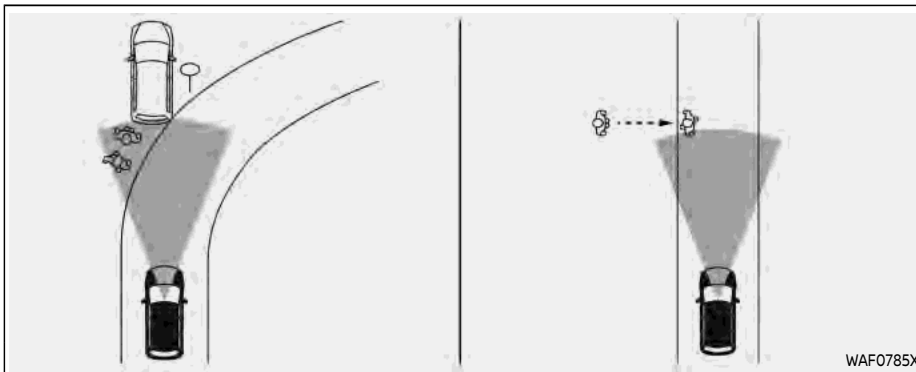

WARNING

Listed below are the system limitations for the AEB with Pedestrian Detection system. Failure to operate the vehicle in accordance with these system limitations could result in serious injury or death.

- The AEB with Pedestrian Detection system may react to:
 - objects on the roadside (traffic sign, guardrail, pedestrian, cyclist, motorcycle, vehicle, etc.)

- pedestrians or cyclists when driving on the narrow alleys, etc.
- pedestrians or cyclists who temporarily protrude into or approaching the driving lane to avoid the obstacles on the road shoulder
- objects above road (low bridge, traffic sign, etc.)
- objects on the road surface (railroad track, grate, steel plate, etc.)

- objects in the parking garage (beam, pillar, etc.)
 - pedestrians, cyclists or motorcycles approaching the traveling lane
 - vehicles, pedestrians, cyclists, motorcycles or objects in adjacent lanes or close to the vehicle
 - oncoming pedestrians, cyclists
 - objects on the road (such as trees)
- **Braking distances increase on slippery surfaces.**
 - **Excessive noise will interfere with the warning chime sound, and the chime may not be heard.**

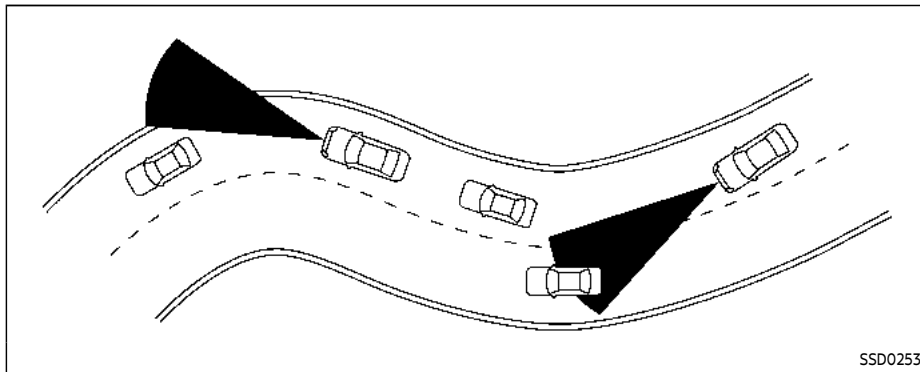

SSD0253

When driving on some roads, such as winding, hilly, curved, narrow roads, or roads which are under construction or on a slope, the sensor may detect vehicles in a different lane, or may temporarily not detect a vehicle traveling ahead. This may cause the system to work inappropriately.

The detection of vehicles may also be affected by vehicle operation (steering maneuver or traveling position in the lane, etc.) or vehicle condition. **If this occurs, the system may warn you by blinking the system indicator and sounding the chime unexpectedly. You will have to manually control the proper distance away from the vehicle traveling ahead.**

SYSTEM TEMPORARILY UNAVAILABLE

Condition A

If the following conditions, the AEB system OFF warning light will flash (no message appears in the vehicle information display).

- Strong light is shining from the front of the vehicle.
- The cabin temperature is over approximately 104°F (40°C) in direct sunlight.
- The camera area of the windshield is misted or frozen.

- The camera unit detects it's misalignment condition.
- The radar sensor picks up interference from another radar source.

Action to take:

When the above conditions no longer exist, the AEB with Pedestrian Detection system will resume automatically.

NOTE:

When the inside of the windshield on camera area is misted or frozen, it will take a period of time to remove it after air conditioner turns on. If dirt appears on this area, it is recommended you visit a NISSAN dealer.

Condition B

In the following condition, the AEB system OFF warning light will flash and the "Forward Driving Aids temporarily disabled Front Sensor blocked" warning message will appear in the vehicle information display.

- The sensor area of the front of the vehicle is covered with dirt or is obstructed

Action to take:

If the warning light flashes, stop the vehicle in a safe place and turn the engine off. Clean the radar cover on the front of the vehicle with a soft cloth, and restart

the engine. If the warning message continues to appear, have the AEB with Pedestrian Detection system checked. It is recommended that you visit a NISSAN dealer for this service.

- When driving on roads with limited road structures or buildings (for example, long bridges, deserts, snow fields, driving next to long walls).

Action to take:

When the above conditions no longer exist, the AEB with Pedestrian Detection system will resume automatically.

Condition C

When the Vehicle Dynamic Control (VDC) system is OFF, the AEB brake will not operate. In this case only visible and audible warning operates. The AEB system OFF warning light (orange) will illuminate.

Action to take:

When the VDC system is ON, the AEB with Pedestrian Detection system will resume automatically.

SYSTEM MALFUNCTION

If the AEB with Pedestrian Detection system malfunctions, it will be turned off automatically, a chime will sound, the AEB system OFF warning light will (orange) will illuminate and the "Malfunction" warning message will appear in the vehicle information display.

Action to take:

If the warning light (orange) comes on, stop the vehicle in a safe location. Turn the engine off and restart the engine. If the warning light continues to illuminate, have the AEB with Pedestrian Detection system checked. It is recommended that you visit a NISSAN dealer for this service.

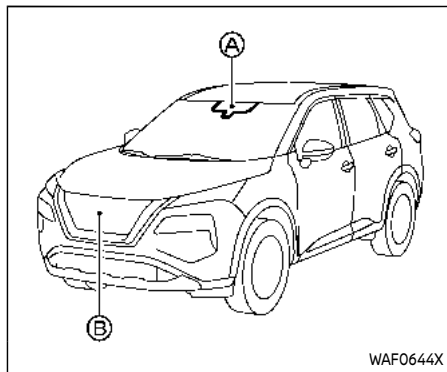

SYSTEM MAINTENANCE

The radar sensor ② is located on the front of the vehicle. The camera ① is located on the upper side of the windshield.

To keep the AEB with Pedestrian Detection system operating properly, be sure to observe the following:

- Always keep the sensor area on the front of the vehicle and windshield clean.
- Do not strike or damage the areas around the sensors (ex. bumper, windshield).
- Do not cover or attach stickers or similar objects on the front of the vehicle near the sensor area. This

could cause failure or malfunction.

- Do not attach metallic objects near the radar sensor area (brush guard, etc.). This could cause failure or malfunction.
- Do not place reflective materials, such as white paper or a mirror, on the instrument panel. The reflection of sunlight may adversely affect the camera unit's detection capability.
- Do not alter, remove or paint the front of the vehicle near the sensor area. Before customizing or restoring the sensor area, it is recommended that you visit a NISSAN dealer.

Radio frequency statement

For USA

Type approval number:

FCC ID: NF3-FR5CPEC

User Manual statement according to §15.19:

This device complies with Part 15 of the FCC Rules.

Operation is subject to the following two conditions:

1. this device may not cause harmful interference, and
2. this device must accept any interference received, including interference

that may cause undesired operation.

User Manual statement according to §15.21:

Changes or modifications made to this equipment not expressly approved by Robert BOSCH GmbH may void the FCC authorization to operate this equipment.

User Manual statement according to §15.105:

This equipment has been tested and found to comply with the limits for a Class A digital device, pursuant to Part 15 of the FCC Rules. These limits are designed to provide reasonable protection against harmful interference when the equipment is operated in a commercial environment. This equipment generates, uses, and can radiate radio frequency energy and, if not installed and used in accordance with the instruction manual, may cause harmful interference to radio communications. Operation of this equipment in a residential area is likely to cause harmful interference in which case the user will be required to correct the interference at his own expense.

RF Exposure Information according 2.1091/2.1093/OET bulletin 65:

Radiofrequency radiation exposure information:

This equipment complies with FCC radi-

INTELLIGENT FORWARD COLLISION WARNING (I-FCW)

tion exposure limits set forth for an uncontrolled environment. This equipment should be installed and operated with minimum distance of 20 cm between the radiator and your body.

The transmitter must not be co-located or operating in conjunction with any other antenna or transmitter.

For Canada

Type approval number:

IC: 3387A-FR5CPEC

Legal warning for RF equipment:

This device complies with Industry Canada licence-exempt RSS standard(s). Operation is subject to the following two conditions: (1) this device may not cause interference, and (2) this device must accept any interference, including interference that may cause undesired operation of the device.





WARNING

Failure to follow the warnings and instructions for proper use of the I-FCW system could result in serious injury or death.

- **The I-FCW system helps warn the driver before a collision but will not avoid a collision. It is the driver's responsibility to stay alert, drive safely and be in control of the vehicle at all times.**

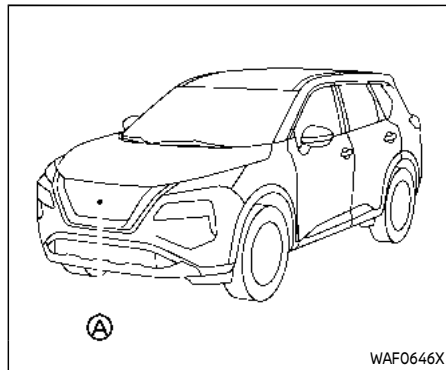
The I-FCW system can help alert the driver when there is a sudden braking of a second vehicle traveling in front of the vehicle ahead in the same lane.



The I-FCW system uses a radar sensor  located on the front of the vehicle to measure the distance to a second vehicle ahead in the same lane.

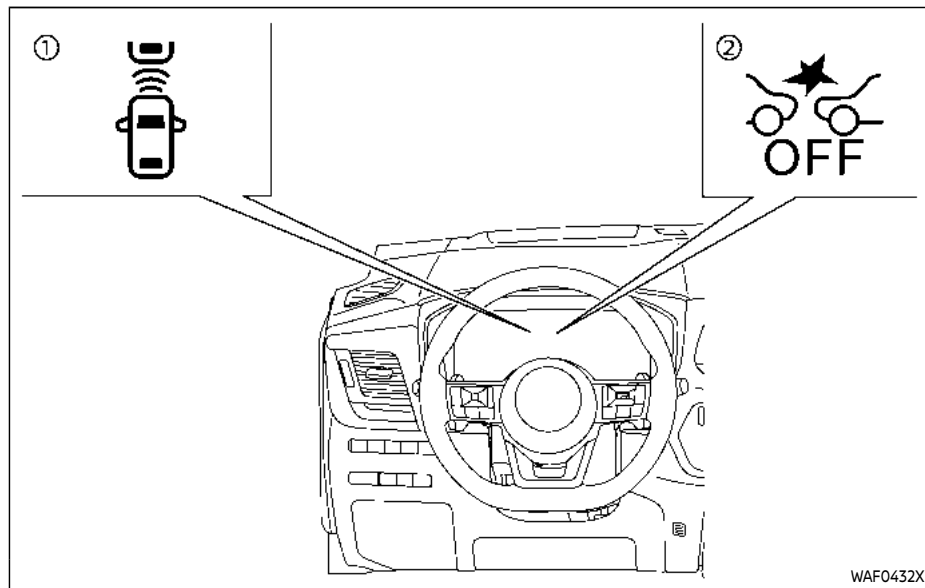

WAF0432X

- ① Vehicle ahead detection indicator (on the vehicle information display)
- ② Automatic Emergency Braking (AEB) system OFF warning light (on the meter panel)

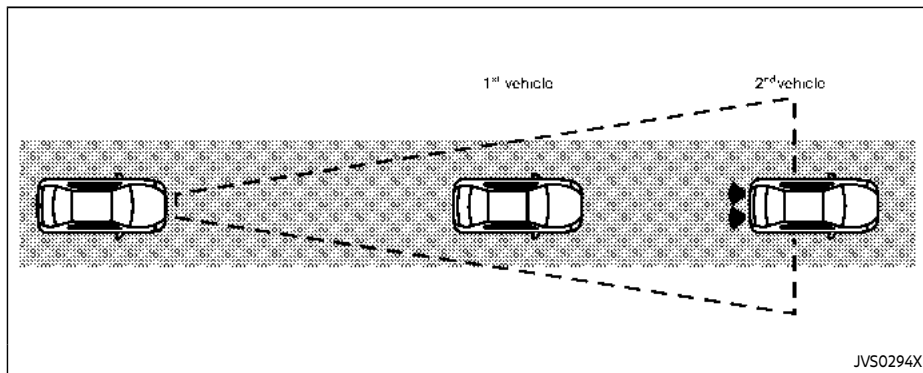

I-FCW SYSTEM OPERATION

The I-FCW system operates at speeds above approximately 3 MPH (5 km/h).

If there is a potential risk of a forward collision, the I-FCW system will warn the driver by blinking the vehicle ahead detection indicator, and sounding an audible alert.

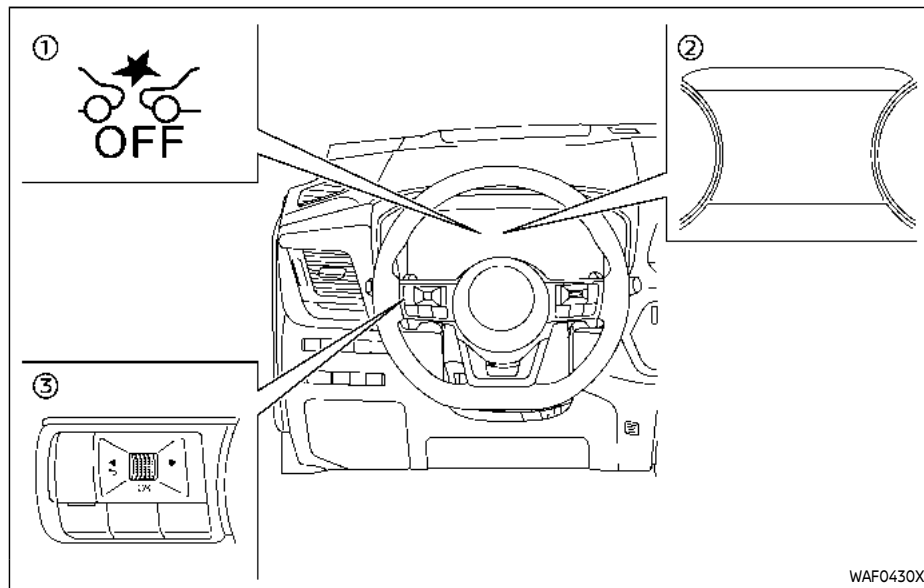

- ① AEB system OFF warning light (on the meter panel)
- ② Vehicle information display
- ③ Steering-wheel-mounted controls (left side)

TURNING THE I-FCW SYSTEM ON/ OFF

Perform the following steps to turn the I-FCW system on or off.

1. Push the ◀ ▶ button until "Settings" appears in the vehicle information display and then push the scroll

dial. Use the scroll dial to select "Driver Assistance." Then push the scroll dial.

2. Select "Emergency Assist" and push the scroll dial.
3. Select "Emergency Braking" and use the scroll dial to turn the system on or off.

When the I-FCW system is turned off, the AEB system OFF warning light (orange) illuminates.

NOTE:

- The I-FCW system will be automatically turned on when the engine is restarted.
- The I-FCW system is integrated into the AEB system. There is not a separate selection for the I-FCW system. When the AEB system is turned off, the I-FCW system is also turned off.

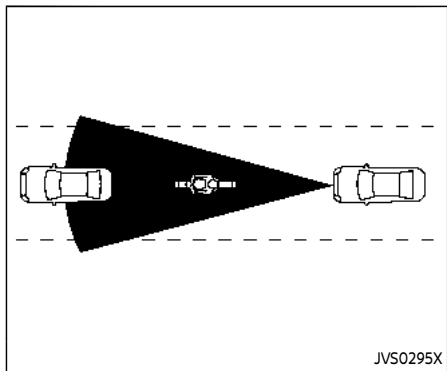

Illustration A

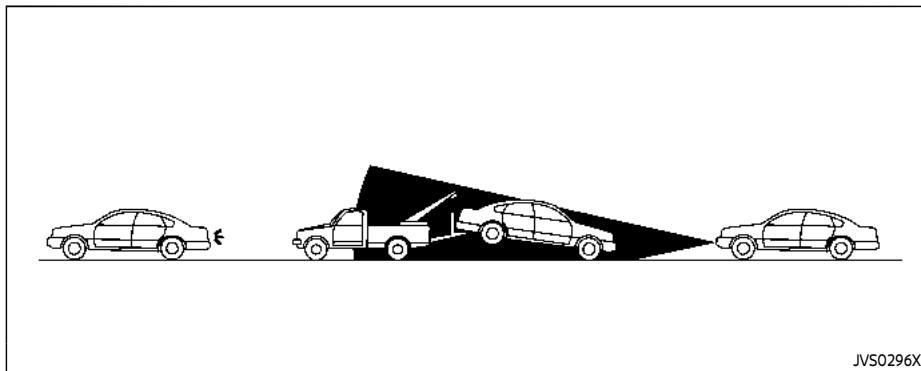

Illustration B

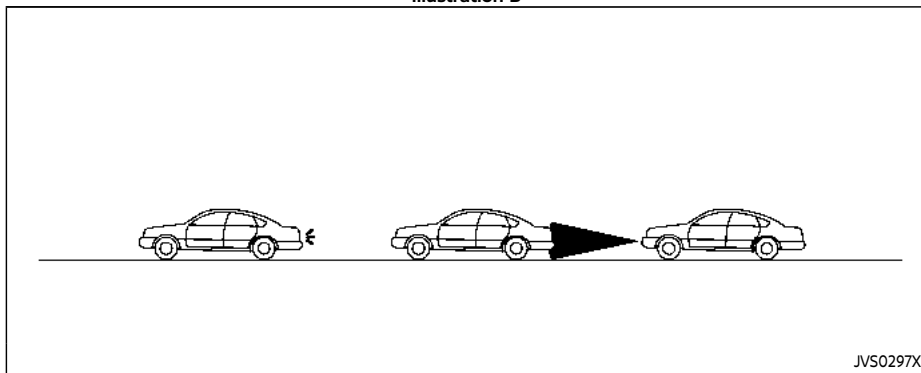

Illustration C

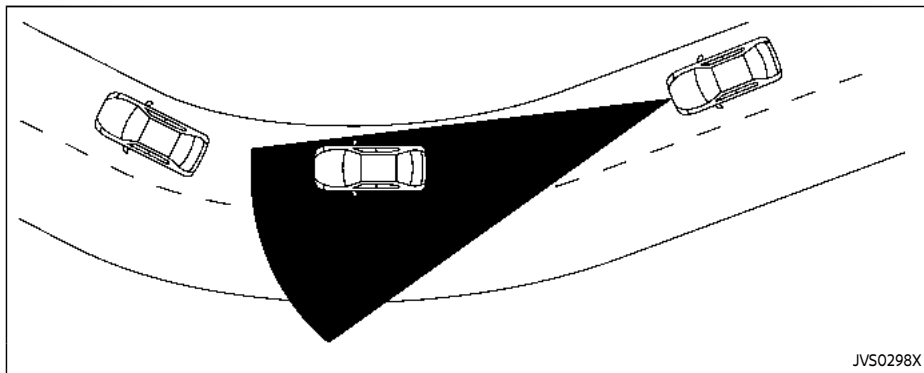

Illustration D

I-FCW SYSTEM LIMITATIONS

WARNING

Listed below are the system limitations for the I-FCW system. Failure to operate the vehicle in accordance with these system limitations could result in serious injury or death.

- The I-FCW system cannot detect all vehicles under all conditions.
- The radar sensor does not detect the following objects:

- Pedestrians, animals or obstacles in the roadway
- Oncoming vehicles
- Crossing vehicles
- (Illustration A) The I-FCW system does not function when a vehicle ahead is a narrow vehicle, such as a motorcycle.
- The radar sensor may not detect a vehicle ahead in the following conditions:
 - Snow or heavy rain

- Dirt, ice, snow or other material covering the radar sensor
- Interference by other radar sources
- Snow or road spray from travelling vehicles.
- Driving in a tunnel
- Towing a trailer
- (Illustration B) When the vehicle ahead is being towed.
- (Illustration C) When the distance to the vehicle ahead is too close, the beam of the radar sensor is obstructed.
- (Illustration D) When driving on a steep downhill slope or roads with sharp curves.
- The system is designed to automatically check the sensor's functionality, within certain limitations. The system may not detect some forms of obstruction of the sensor area such as ice, snow, stickers, for example. In these cases, the system may not be able to warn the driver properly. Be sure that you check, clean and clear the sensor area regularly.

- Excessive noise will interfere with the warning chime sound, and the chime may not be heard.

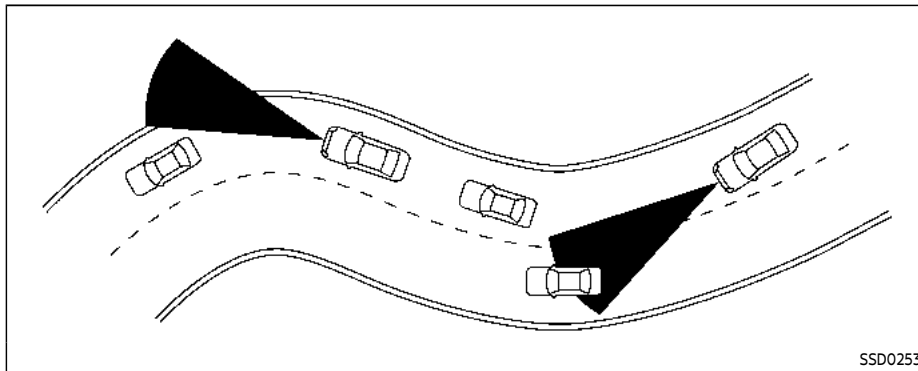

When driving on some roads, such as winding, hilly, curved, narrow roads, or roads which are under construction, the radar sensor may detect vehicles in a different lane, or may temporarily not detect a vehicle traveling ahead. This may cause the I-FCW system to work inappropriately.

The detection of vehicles may also be affected by vehicle operation (steering maneuver or traveling position in the lane, etc.) or vehicle condition. **If this occurs, the system may warn you by blinking the vehicle ahead detection indicator and sounding the chime unexpectedly. You will have to manually control the proper distance away from**

the vehicle traveling ahead.

SYSTEM TEMPORARILY UNAVAILABLE

Condition A

When the radar sensor picks up interference from another radar source, making it impossible to detect a vehicle ahead, the I-FCW system is automatically turned off. The AEB system OFF warning light (orange) will flash.

Action to take:

When the above conditions no longer exist, the I-FCW system will resume automatically.

Condition B

Under the following conditions, making it impossible to detect a vehicle ahead, the I-FCW system is automatically turned off.

The AEB system OFF warning light (orange) will flash and the "Forward Driving Aids temporarily disabled Front Sensor blocked" warning message will appear in the vehicle information display.

- When the sensor area of the front of the vehicle is covered with dirt or is obstructed

Action to take:

If the warning light (orange) flashes, stop the vehicle in a safe place, push the park button to engage the P (Park) position and turn the engine off. Clean the radar cover on the front of the vehicle with a soft cloth, and restart the engine. If the warning light continues to illuminate, have the I-FCW system checked. It is recommended you visit a NISSAN dealer for this service.

- When driving on roads with limited road structures or buildings (for example, long bridges, deserts, snow fields, driving next to long walls)

Action to take:

When the above conditions no longer exist, the I-FCW system will resume automatically.

SYSTEM MALFUNCTION

If the I-FCW system malfunctions, it will be turned off automatically, a chime will sound, the AEB system OFF warning light (orange) will illuminate and the "Malfunction" warning message will appear in the vehicle information display.

Action to take:

If the warning light (orange) illuminates, stop the vehicle in a safe location. Turn the engine off and restart the engine. If the warning light continues to illuminate, have the I-FCW system checked. It is recommended you visit a NISSAN dealer for this service.

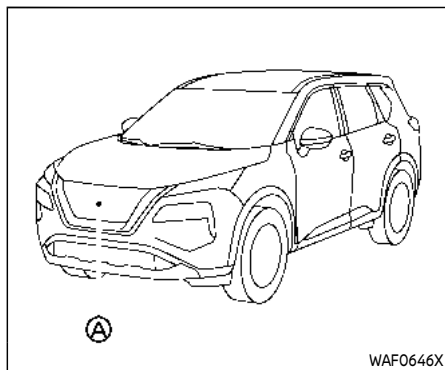

SYSTEM MAINTENANCE

The radar sensor (A) is located on the front of the vehicle.

To keep the system operating properly, be sure to observe the following:

- Always keep the sensor area on the front of the vehicle clean.
- Do not strike or damage the areas around the sensor.
- Do not cover or attach stickers or similar objects on the front bumper near the sensor area. This could cause failure or malfunction.
- Do not attach metallic objects near the sensor area (brush guard, etc.). This could cause failure or malfunction.

tion.

- Do not alter, remove or paint the front bumper. It is recommended you contact a NISSAN dealer before customizing or restoring the front bumper.

Radio frequency statement

For USA

Type approval number:

FCC ID: NF3-FR5CPEC

User Manual statement according to §15.19:

This device complies with Part 15 of the FCC Rules.

Operation is subject to the following two conditions:

1. this device may not cause harmful interference, and
2. this device must accept any interference received, including interference that may cause undesired operation.

User Manual statement according to §15.21:

Changes or modifications made to this equipment not expressly approved by Robert BOSCH GmbH may void the FCC authorization to operate this equipment.

User Manual statement according to §15.105:

This equipment has been tested and found to comply with the limits for a Class A digital device, pursuant to Part 15 of the FCC Rules. These limits are designed to provide reasonable protection against harmful interference when the equipment is operated in a commercial environment. This equipment generates, uses, and can radiate radio frequency energy and, if not installed and used in accordance with the instruction manual, may cause harmful interference to radio communications. Operation of this equipment in a residential area is likely to cause harmful interference in which case the user will be required to correct the interference at his own expense.

RF Exposure Information according 2.1091/2.1093/OET bulletin 65:

Radiofrequency radiation exposure information:

This equipment complies with FCC radiation exposure limits set forth for an uncontrolled environment. This equipment should be installed and operated with minimum distance of 20 cm between the radiator and your body.

The transmitter must not be co-located or operating in conjunction with any other antenna or transmitter.

For Canada

Type approval number:

IC: 3387A-FR5CPEC

Legal warning for RF equipment:

This device complies with Industry Canada licence-exempt RSS standard(s). Operation is subject to the following two conditions: (1) this device may not cause interference, and (2) this device must accept any interference, including interference that may cause undesired operation of the device.

INTELLIGENT DRIVER ALERTNESS (I-DA)



WARNING

Failure to follow the warnings and instructions for proper use of the I-DA system could result in serious injury or death.

- The I-DA system is only a warning to inform the driver of a potential lack of driver attention or drowsiness. It will not steer the vehicle or prevent loss of control.
- The I-DA system does not detect and provide an alert of the driver's lack of attention or fatigue in every situation.
- It is the driver's responsibility to:
 - Stay alert.
 - Drive safely.
 - Keep the vehicle in the traveling lane.
 - Be in control of the vehicle at all times.
 - Avoid driving when tired.
 - Avoid distractions (texting, etc).

The I-DA system helps alert the driver if the system detects a lack of attention or driving fatigue.

The system monitors driving style and steering behavior over a period of time, and it detects changes from the normal pattern. If the system detects that driver attention is decreasing over a period of time, the system uses audible and visual warnings to suggest that the driver take a break.

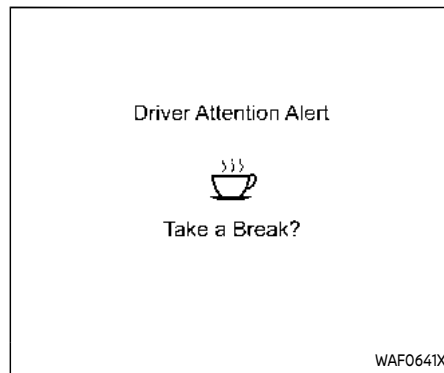

Example

I-DA SYSTEM OPERATION

If the system detects driver fatigue or that driver attention is decreasing, the message "Take a Break?" appears in the vehicle information display and a chime sounds when the vehicle is driven at speeds above 37 MPH (60 km/h).

The system continuously monitors driver attention and can provide multiple warnings per trip.

The system resets and starts reassessing driving style and steering behavior when the ignition switch is cycled from the ON to the OFF position and back to the ON position.

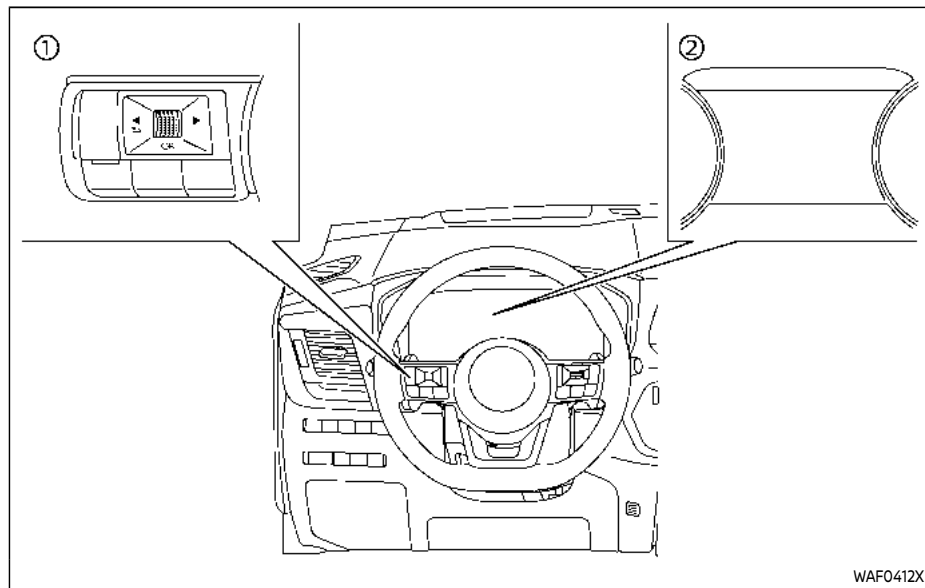

- ① Steering-wheel-mounted control (left side)
- ② Vehicle information display

HOW TO ENABLE/DISABLE THE I-DA SYSTEM

Perform the following steps to enable or disable the I-DA system.

1. Push the ◀ ▶ button until "Settings" appears in the vehicle information display and push the scroll dial.

Use the scroll dial to select "Driver Assistance." Then push the scroll dial.

2. Select "Driver Alertness" and push the scroll dial.

NOTE:

The setting will be retained even if the engine is restarted.

I-DA SYSTEM LIMITATIONS

WARNING

Listed below are the system limitations for the I-DA system. Failure to operate the vehicle in accordance with these system limitations could result in serious injury or death.

- The I-DA system may not operate properly and may not provide an alert in the following conditions:
 - Poor road conditions such as an uneven road surface or pot holes.
 - Strong side wind.
 - If you have adopted a sporty driving style with higher cornering speeds or higher rates of acceleration.

REAR AUTOMATIC BRAKING (RAB)

- Frequent lane changes or changes to vehicle speed.
- The I-DA system will not provide an alert in the following conditions:
 - Vehicle speeds lower than 37 mph (60 km/h).
 - Short lapses of attention.
 - Instantaneous distractions such as dropping an object.

SYSTEM MALFUNCTION

If the I-DA system malfunctions, the “Driver Attention Alert Malfunction” warning message will appear in the vehicle information display and the function will be stopped automatically.

Action to take

Stop the vehicle in a safe location, place the vehicle in P (Park) position, turn the engine off and restart the engine. If the warning message continues to appear, have the system checked. It is recommended that you visit a NISSAN dealer for this service.



WARNING

Failure to follow the warnings and instructions for proper use of the RAB system could result in serious injury or death.

- The RAB system is a supplemental aid to the driver. It is not a replacement for proper driving procedures. Always use the side and rear mirrors and turn and look in the direction you will move before and while backing up. **Never rely solely on the RAB system. It is the driver's responsibility to stay alert, drive safely, and be in control of the vehicle at all times.**
- There is a limitation to the RAB system capability. **The RAB system is not effective in all situations.**

The RAB system can assist the driver when the vehicle is backing up and approaching objects directly behind the vehicle.

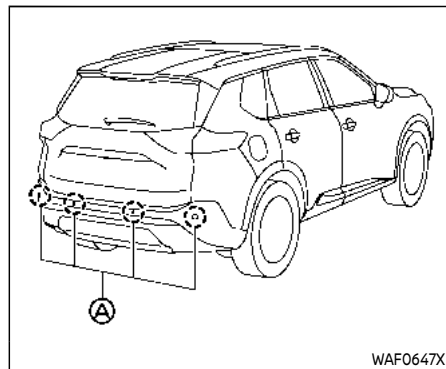

Models with 4 sonar sensors

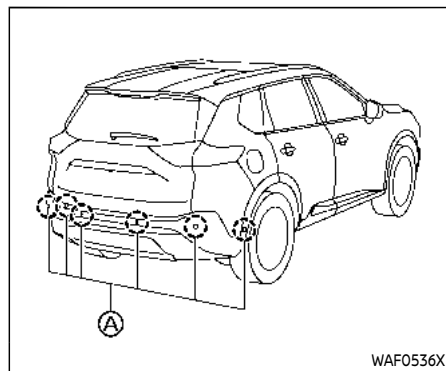

Models with 6 sonar sensors

The RAB system detects obstacles behind the vehicle using the sonar sensors  located on the rear bumper.

NOTE:

You can temporarily cancel the sonar function and the RAB system in the vehicle. For additional information, see “Sonar system” (P.5-162) or “Rear Sonar System (RSS)” (P.5-168).

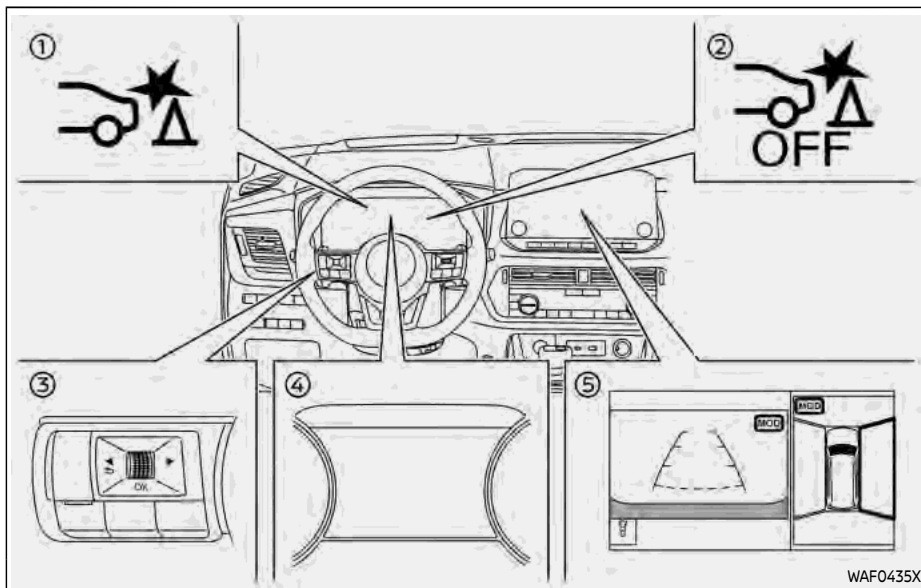

- ① RAB system warning indicator (on the vehicle information display)
- ② RAB system OFF warning light (on the meter panel)
- ③ Steering-wheel-mounted controls (left side)
- ④ Vehicle information display
- ⑤ Center display (if so equipped)

RAB SYSTEM OPERATION

When the shift lever is in the R (Reverse) position and the vehicle speed is less than approximately 9 MPH (15 km/h), the RAB system operates.

If a risk of a collision with an obstacle is detected when your vehicle is backing up, the RAB system warning indicator will flash in the vehicle information display, a red frame will appear in the center display (models with the Intelligent Around View® Monitor system), and the system will chime three times. The system will then automatically apply the brakes. After the automatic brake application, the driver must depress the brake pedal to maintain brake pressure.

NOTE:

- **The stop lights of the vehicle come on when braking is performed by the RAB system.**
- **When the brakes operate, a noise may be heard. This is not a malfunction.**

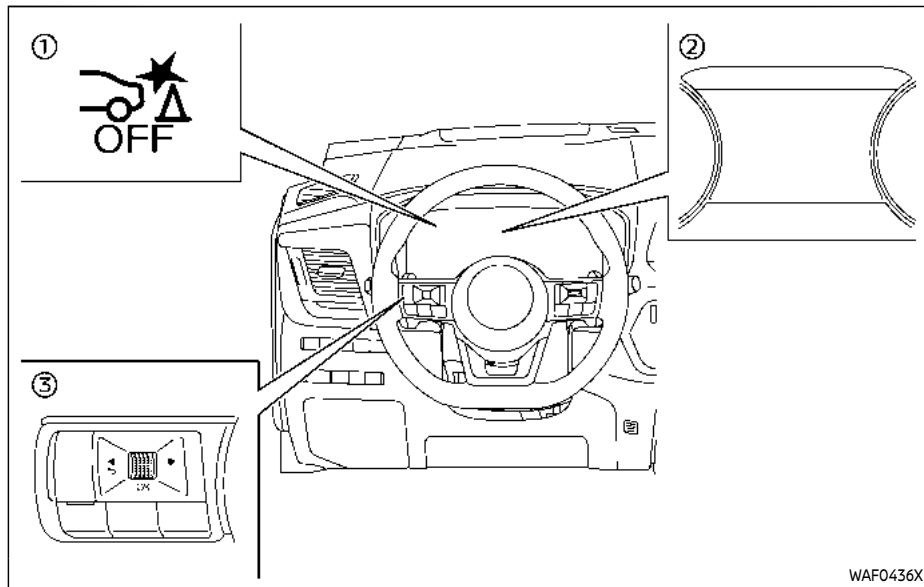

- ① RAB system OFF warning light
- ② Vehicle information display
- ③ Steering-wheel-mounted control (left side)

TURNING THE RAB SYSTEM ON/OFF

Perform the following steps to turn the RAB system ON or OFF.

1. Push the ◀ ▶ button until "Settings" appears in the vehicle information display and then push the scroll dial. Use the scroll dial to select "Driver

Assistance.” Then push the scroll dial.

2. Select “Emergency Assist” and push the scroll dial.
3. Select “Rear Auto Braking” and use the scroll dial to turn the system on or off.

When the RAB system is turned off, the RAB system OFF warning light illuminates.

NOTE:

The RAB system will be automatically turned on when the engine is restarted.

RAB SYSTEM LIMITATIONS



WARNING

Listed below are the system limitations for the RAB system. Failure to follow the warnings and instructions for proper use of the RAB system could result in serious injury or death.

- When the vehicle approaches an obstacle while the accelerator or brake pedal is depressed, the function may not operate or the start of the operation may be delayed. The RAB system may not operate or may not perform sufficiently due to vehicle conditions, driving conditions, the traffic environment, the weather,

road surface conditions, etc. Do not wait for the system to operate. Operate the brake pedal by yourself as soon as necessary.

- If it is necessary to override RAB operation, strongly press the accelerator pedal.
- Always check your surroundings and turn to check what is behind you before and while backing up. The RAB system detects stationary objects behind the vehicle. The RAB system does not detect the following objects:
 - Moving objects
 - Low objects
 - Narrow objects
 - Wedge-shaped objects
 - Complex-shaped objects
 - Multiple object in close
 - Objects close to the bumper (less than approximately 1 ft [30 cm])
 - Objects that suddenly appear
 - Thin objects such as rope, wire, chain, etc.

- The RAB system may not operate for pedestrians or animals.
- The RAB system may not operate for the following obstacles:
 - Obstacles located high off the ground
 - Obstacles in a position offset from your vehicle
 - Obstacles, such as spongy materials or snow, that have soft outer surfaces and can easily absorb a sound wave
- The RAB system may not operate in the following conditions:
 - There is rain, snow, ice, dirt, etc., attached to the sonar sensors.
 - A loud sound is heard in the area around the vehicle.
 - The surface of the obstacle is diagonal to the rear of the vehicle.
 - The sonar sensors or the area around them are extremely hot or cold.
- The RAB system may unintentionally operate in the following conditions:

- There is overgrown grass in the area around the vehicle.
- There is a structure (e.g., a wall, toll gate equipment, a narrow tunnel, a parking lot gate) near the side of the vehicle.
- There are bumps, protrusions, or manhole covers on the road surface.
- The vehicle is driving through a draped flag or a curtain.
- The vehicle is driving on a steep hill.
- There is an accumulation of snow or ice behind the vehicle.
- An ultrasonic wave source, such as another vehicle's sonar, is near the vehicle.
- Once the automatic brake control operates, it does not operate again if the vehicle approaches the same obstacle.
- The automatic brake control can only operate for a short period of time. Therefore, the driver must depress the brake pedal.

- In the following situations, the RAB system may not operate properly or may not function sufficiently:
 - The vehicle is driven in bad weather (rain, fog, snow, etc.).
 - The vehicle is driven on a steep hill.
 - The vehicle's posture is changed (e.g., when driving over a bump).
 - The vehicle is driven on a slippery road.
 - The vehicle is turned sharply by turning the steering wheel fully.
 - Snow chains are used.
 - Wheels or tires other than NISSAN recommended are used.
 - The brakes are cold at low ambient temperatures or immediately after driving has started.
 - The braking force becomes poor due to wet brakes after driving through a puddle or washing the vehicle.

- Turn the RAB system off in the following conditions to prevent the occurrence of an unexpected activation resulting from sudden system operation:
 - The vehicle is towed.
 - The vehicle is carried on a flatbed truck.
 - The vehicle is on the chassis dynamometer.
 - The vehicle drives on an uneven road surface.
 - The vehicle is towing an object (if so equipped).
 - Suspension parts other than those designated as genuine parts are used. (If the vehicle height or the vehicle body inclination is changed, the system may not detect an obstacle correctly.)
 - If the vehicle is using an accessory like a bike rack or cargo carrier that blocks the sensors.
- Excessive noise (e.g., audio system volume, an open vehicle window) will interfere with the chime sound, and it may not be heard.

SYSTEM MALFUNCTION

If the RAB system malfunctions, it will be turned off automatically, the RAB system OFF warning light will illuminate, and the "Malfunction See Owner's Manual" warning message will appear in the vehicle information display.

Action to take

If the warning light illuminates, park the vehicle in a safe location, turn the engine off, and restart the engine. If the warning light continues to illuminate, have the RAB system checked. It is recommended that you visit a NISSAN dealer for this service.

NOTE:

If the RAB system cannot be operated temporarily, the RAB system OFF warning light blinks.

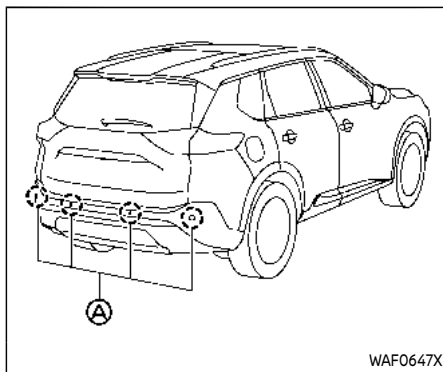

Models with 4 sonar sensors

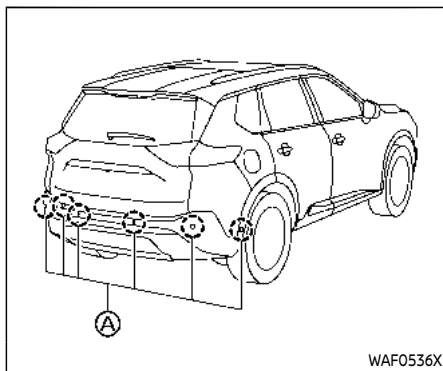

Models with 6 sonar sensors

SYSTEM MAINTENANCE

The sonar sensors (A) are located on the rear bumper. Observe the following items to ensure proper operation of the system:

- Always keep the sonar sensors clean.
- If the sonar sensors are dirty, wipe them off with a soft cloth while being careful to not damage them.
- The sonar sensors may be blocked by temporary ambient conditions such as splashing water, mist or fog. The blocked condition may also be caused by objects such as ice, frost or dirt obstructing the sonar sensors. Check for and remove objects obstructing the area around the sonar sensors.
- Do not subject the area around the sonar sensors to strong impact. Also, do not remove or disassemble the sonar sensors. If the sonar sensors and peripheral areas are deformed in an accident, etc., have the sonar sensors checked. It is recommended that you visit a NISSAN dealer for this service.
- Do not attach stickers (including transparent material), install accessories or apply additional paint on the sonar sensors and their surrounding areas. This may cause a malfunction or improper operation.

- When washing the vehicle using a high-pressure washer, do not apply direct washer pressure on the sonar sensors. This may cause a malfunction of the sonar sensors.

BREAK-IN SCHEDULE



CAUTION

During the first 1,200 miles (2,000 km), follow these recommendations to obtain maximum engine performance and ensure the future reliability and economy of your new vehicle. Failure to follow these recommendations may result in shortened engine life and reduced engine performance.

- Avoid driving for long periods at constant speed, either fast or slow. Do not run the engine over 4,000 rpm.
- Do not accelerate at full throttle in any gear.
- Avoid quick starts.
- Avoid hard braking as much as possible.
- Do not tow a trailer for the first 500 miles (800 km). Your engine, axle or other parts could be damaged.

FUEL EFFICIENT DRIVING TIPS

Follow these easy-to-use Fuel Efficient Driving Tips to help you achieve the most fuel economy from your vehicle.

1. Use smooth accelerator and brake pedal application.
 - Avoid rapid starts and stops.
 - Use smooth, gentle accelerator and brake application whenever possible.
 - Maintain constant speed while commuting and coast whenever possible.
2. Maintain constant speed.
 - Look ahead to try and anticipate and minimize stops.
 - Synchronizing your speed with traffic lights allows you to reduce your number of stops.
 - Maintaining a steady speed can minimize red light stops and improve fuel efficiency.
3. Use air conditioning (A/C) at higher vehicle speeds.
 - Below 40 MPH (64 km/h), it is more efficient to open windows to cool the vehicle due to reduced engine load.
 - Above 40 MPH (64 km/h), it is more efficient to use A/C to cool the vehicle due to increased aerodynamic drag.

- Recirculating the cool air in the cabin when the A/C is on reduces cooling load.
4. Drive at economical speeds and distances.
 - Observing the speed limit and not exceeding 60 MPH (97 km/h) (where legally allowed) can improve fuel efficiency due to reduced aerodynamic drag.
 - Maintaining a safe following distance behind other vehicles reduces unnecessary braking.
 - Safely monitoring traffic to anticipate changes in speed permits reduced braking and smooth acceleration changes.
 - Select a gear range suitable to road conditions.
 5. Use cruise control.
 - Using cruise control during highway driving helps maintain a steady speed.
 - Cruise control is particularly effective in providing fuel savings when driving on flat terrains.
 6. Plan for the shortest route.
 - Utilize a map or navigation system to determine the best route to save time.

7. Avoid idling.
 - Shutting off your engine when safe for stops exceeding 30-60 seconds saves fuel and reduces emissions.
8. Buy an automated pass for toll roads.
 - Automated passes permit drivers to use special lanes to maintain cruising speed through the toll and avoid stopping and starting.
9. Winter warm up.
 - Limit idling time to minimize impact to fuel economy.
 - Vehicles typically need no more than 30 seconds of idling at start-up to effectively circulate the engine oil before driving.
 - Your vehicle will reach its ideal operating temperature more quickly while driving versus idling.
10. Keeping your vehicle cool.
 - Park your vehicle in a covered parking area or in the shade whenever possible.
 - When entering a hot vehicle, opening the windows will help to reduce the inside temperature faster, resulting in reduced demand on your A/C system.

INCREASING FUEL ECONOMY

- Keep your engine tuned up.
- Follow the recommended scheduled maintenance.
- Keep the tires inflated to the correct pressure. Low tire pressure increases tire wear and lowers fuel economy.
- Keep the wheels in correct alignment. Improper alignment increases tire wear and lowers fuel economy.
- Use the recommended viscosity engine oil. (See "Engine oil and oil filter recommendation" (P.10-7).)

INTELLIGENT 4X4 (if so equipped)

If any malfunction occurs in the Intelligent 4x4 system while the engine is running, warning messages appear in the vehicle information display.

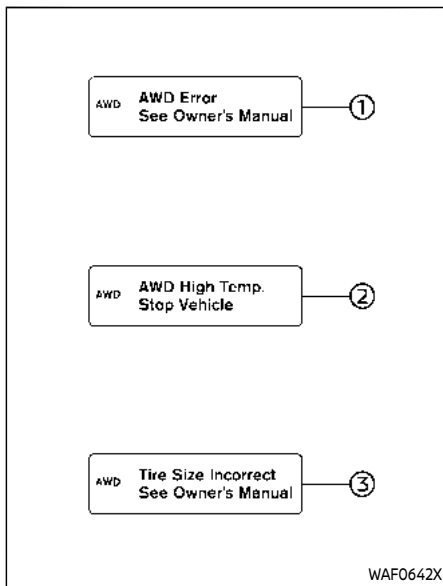

If the "AWD Error" warning ① appears, there may be a malfunction in the Intelligent 4x4 system. Reduce vehicle speed and have your vehicle checked by a NISSAN dealer as soon as possible.

The "AWD High Temp. Stop vehicle" (high temperature) warning ② appears when the oil temperature of the powertrain

parts increases due to the difference in rotation between the front and rear wheels is large (wheel slip), such as when driving on rough roads, driving through sand or mud, or freeing a stuck vehicle. If this warning is displayed, stop the vehicle with the engine idling, as soon as it is safe to do so. In these cases, the AWD changes to 2WD to protect the powertrain parts. Then if the warning turns off, you can continue AWD driving.

The "Tire Size Incorrect" warning ③ may appear if there is a large difference between the diameters of front and rear wheels and tires. Pull off the road in a safe area, with the engine idling. Check that all tire sizes, brand, construction and tread pattern are the same, that the tire pressures are correct and that the tires are not excessively worn. If you have any problems, change tires or adjust tire pressures correctly. Do not select the SNOW or OFF-ROAD mode with the Drive Mode Selector and do not drive fast.

If any warning message continues to be displayed, have your vehicle checked by a NISSAN dealer as soon as possible.



WARNING

- For AWD equipped vehicles, do not attempt to raise two wheels off the ground and shift the transmission to any drive or reverse position with the engine running. Doing so may result in drivetrain damage or unexpected vehicle movement which could result in serious vehicle damage or personal injury.
- Do not attempt to test an AWD equipped vehicle on a 2-wheel dynamometer (such as the dynamometers used by some states for emissions testing) or similar equipment even if the other two wheels are raised off the ground. Make sure that you inform the test facility personnel that your vehicle is equipped with AWD before it is placed on a dynamometer. Using the wrong test equipment may result in drive train damage or unexpected vehicle movement which could result in serious vehicle damage or personal injury.



CAUTION

- Do not operate the engine on a free roller when any of the wheels raised.
- The power train may be damaged if you continue driving with the "AWD Error" warning on.
- If the warning message remains on after the above operation, have your vehicle checked as soon as possible. It is recommended that you visit a NISSAN dealer for this service.
- If the "AWD Error" warning appears while driving, there may be a malfunction in the AWD system.

Reduce the vehicle speed and have your vehicle checked as soon as possible. It is recommended that you visit a NISSAN dealer for this service.

When the vehicle is in the P (Park) position, the operation noise may be heard from the lower part of the vehicle. This is not a malfunction.

PARKING/PARKING ON HILLS

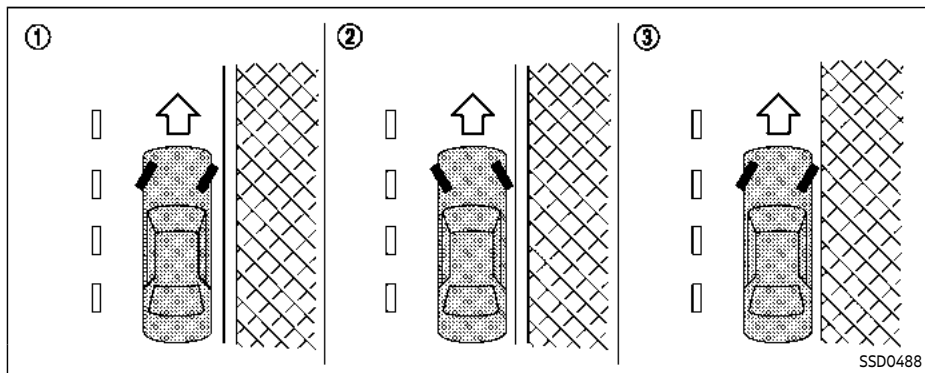

WARNING

- Do not stop or park the vehicle over flammable materials such as dry grass, waste paper or rags. They may ignite and cause a fire.
- Never leave the engine running while the vehicle is unattended.
- Do not leave children unattended inside the vehicle. They could unknowingly activate switches or controls. Unattended children could become involved in serious accidents.

- To help avoid risk of injury or death through unintended operation of the vehicle and/or its systems, do not leave children, people who require the assistance of others or pets unattended in your vehicle. Additionally, the temperature inside a closed vehicle on a warm day can quickly become high enough to cause a significant risk of injury or death to people and pets.
- Safe parking procedures require that both the parking brake be applied and the transmission

placed into P (Park). Failure to do so could cause the vehicle to move unexpectedly or roll away and result in an accident.

- Make sure the shift lever cannot be moved without depressing the foot brake pedal.
1. Apply the parking brake.
 2. Push the park button to shift to the P (Park) position.
 3. To help prevent the vehicle from rolling into the street when parked on a sloping drive way, it is a good practice to turn the wheels as illustrated.
 - HEADED DOWNHILL WITH CURB: ①
Turn the wheels into the curb and move the vehicle forward until the curb side wheel gently touches the curb.
 - HEADED UPHILL WITH CURB: ②
Turn the wheels away from the curb and move the vehicle back until the curb side wheel gently touches the curb.
 - HEADED UPHILL OR DOWNHILL, NO CURB: ③
Turn the wheels toward the side of the road so the vehicle will move away from the center of the road if it moves.

ELECTRIC POWER STEERING

- Place the ignition switch in the OFF position.



WARNING

- If the engine is not running or is turned off while driving, the power assist for the steering will not work. Steering will be harder to operate.**
- When the electric power steering warning light illuminates with the engine running, the power assist for the steering will cease operation. You will still have control of the vehicle but the steering will be harder to operate.**

The electric power steering is designed to provide power assist while driving to operate the steering wheel with light force.

When SPORT mode is selected, the steering wheel effort is moderately increased for a sporty feel. (See "SPORT mode" (P.5-34).)

When the steering wheel is operated repeatedly or continuously while parking or driving at a very low speed, the power assist for the steering wheel will be reduced. This is to prevent overheating of the electric power steering and protect it from getting damaged. While the power

assist is reduced, steering wheel operation will become heavy. If the steering wheel operation is still performed, the electric power steering may stop and the electric power steering warning light  will illuminate. In a safe location, stop the engine and place the ignition switch in the OFF position. When the temperature of the electric power steering goes down, the power assist level will return to normal. Avoid repeating such steering wheel operations that could cause the electric power steering to overheat.

You may hear a noise when the steering wheel is operated quickly. However, this is not a malfunction.

If the electric power steering warning light illuminates while the engine is running, it may indicate the electric power steering is not functioning properly and may need servicing. Have the electric power steering checked. It is recommended that you visit a NISSAN dealer for this service. (See "Electric power steering warning light" (P.2-17).)

When the electric power steering warning light illuminates with the engine running, the power assist for the steering will cease operation. You will still have control of the vehicle. However, greater steering effort is needed, especially in sharp turns and at low speeds.

BRAKE SYSTEM

BRAKING PRECAUTIONS

The brake system has two separate hydraulic circuits. If one circuit malfunctions, you will still have braking at two wheels.

Vacuum assisted brakes

The brake booster aids braking by using engine vacuum. If the engine stops, you can stop the vehicle by depressing the brake pedal. However, greater foot pressure on the brake pedal will be required to stop the vehicle and the stopping distance will be longer.

Using the brakes

Avoid resting your foot on the brake pedal while driving. This will cause overheating of the brakes, wearing out the brake pads faster and reduce gas mileage.

To help reduce brake wear and to prevent the brakes from overheating, reduce speed and downshift to a lower gear before going down a slope or long grade. Overheated brakes may reduce braking performance and could result in loss of vehicle control.



WARNING

- **While driving on a slippery surface, be careful when braking, accelerating or downshifting. Abrupt braking or accelerating could cause the wheels to skid and result in an accident.**
- **If the engine is not running or is turned off while driving, the power assist for the brakes will not work. Braking will be harder.**

Wet brakes

When the vehicle is washed or driven through water, the brakes may get wet. As a result, your braking distance will be longer and the vehicle may pull to one side during braking.

To dry brakes, drive the vehicle at a safe speed while lightly tapping the brake pedal to heat-up the brakes. Do this until the brakes return to normal. Avoid driving the vehicle at high speeds until the brakes function correctly.

Parking brake break-in

Break in the parking brake pads whenever the stopping effect of the parking brake is weakened or whenever the parking brake pads and/or calipers/rotors are replaced, in order to assure the best braking performance.

This procedure is described in the vehicle service manual. It is recommended you visit a NISSAN dealer for this service.

BRAKE ASSIST

BRAKE ASSIST

When the force applied to the brake pedal exceeds a certain level, the Brake Assist is activated generating greater braking force than a conventional brake booster even with light pedal force.



WARNING

The Brake Assist is only an aid to assist braking operation and is not a collision warning or avoidance device. It is the driver's responsibility to stay alert, drive safely and be in control of the vehicle at all times.

ANTI-LOCK BRAKING SYSTEM (ABS)



WARNING

- The Anti-lock Braking System (ABS) is a sophisticated device, but it cannot prevent accidents resulting from careless or dangerous driving techniques. It can help maintain vehicle control during braking on slippery surfaces. Remember that stopping distances on slippery surfaces will be longer than on normal sur-

faces even with ABS. Stopping distances may also be longer on rough, gravel or snow covered roads, or if you are using tire chains. Always maintain a safe distance from the vehicle in front of you. Ultimately, the driver is responsible for safety.

- Tire type and condition may also affect braking effectiveness.
 - When replacing tires, install the specified size of tires on all four wheels.
 - When installing a spare tire, make sure that it is the proper size and type as specified on the Tire and Loading Information label. See "Tire and Loading Information label" (P.10-13) of this manual.
 - For detailed information, see "Wheels and tires" (P.8-30) of this manual.

The Anti-lock Braking System (ABS) controls the brakes so the wheels do not lock during hard braking or when braking on slippery surfaces. The system detects the rotation speed at each wheel and varies the brake fluid pressure to prevent each wheel from locking and sliding. By pre-

venting each wheel from locking, the system helps the driver maintain steering control and helps to minimize swerving and spinning on slippery surfaces.

Using the system

Depress the brake pedal and hold it down. Depress the brake pedal with firm steady pressure, but do not pump the brakes. The ABS will operate to prevent the wheels from locking up. Steer the vehicle to avoid obstacles.



WARNING

Do not pump the brake pedal. Doing so may result in increased stopping distances.

Self-test feature

The ABS includes electronic sensors, electric pumps, hydraulic solenoids and a computer. The computer has a built-in diagnostic feature that tests the system each time you start the engine and move the vehicle at a low speed in forward or reverse. When the self-test occurs, you may hear a "clunk" noise and/or feel a pulsation in the brake pedal. This is normal and does not indicate a malfunction. If the computer senses a malfunc-

VEHICLE DYNAMIC CONTROL (VDC) SYSTEM

tion, it switches the ABS off and illuminates the ABS warning light on the instrument panel. The brake system then operates normally, but without anti-lock assistance.

If the ABS warning light illuminates during the self-test or while driving, have the vehicle checked. It is recommended you visit a NISSAN dealer for this service.

Normal operation

The ABS operates at speeds above 3 to 6 MPH (5 to 10 km/h). The speed varies according to road conditions.

When the ABS senses that one or more wheels are close to locking up, the actuator rapidly applies and releases hydraulic pressure. This action is similar to pumping the brakes very quickly. You may feel a pulsation in the brake pedal and hear a noise from under the hood or feel a vibration from the actuator when it is operating. This is normal and indicates that the ABS is operating properly. However, the pulsation may indicate that road conditions are hazardous and extra care is required while driving.

The Vehicle Dynamic Control (VDC) system uses various sensors to monitor driver inputs and vehicle motion. Under certain driving conditions, the VDC system helps to perform the following functions.



- Controls brake pressure to reduce wheel slip on one slipping drive wheel so power is transferred to a non slipping drive wheel on the same axle.
- Controls brake pressure and engine output to reduce drive wheel slip based on vehicle speed (traction control function).
- Controls brake pressure at individual wheels and engine output to help the driver maintain control of the vehicle in the following conditions:
 - understeer (vehicle tends to not follow the steered path despite increased steering input)
 - oversteer (vehicle tends to spin due to certain road or driving conditions).

The VDC system can help the driver to maintain control of the vehicle, but it cannot prevent loss of vehicle control in all driving situations.

When the VDC system operates, the slip indicator light  in the instrument panel flashes so note the following:

- The road may be slippery or the system may determine some action is required to help keep the vehicle on the steered path.
- You may feel a pulsation in the brake pedal and hear a noise or vibration from under the hood. This is normal and indicates that the VDC system is working properly.
- Adjust your speed and driving to the road conditions.

If a malfunction occurs in the system, the slip indicator light  illuminates in the instrument panel. The VDC system automatically turns off.

The vehicle information display is used to turn off the VDC system. The VDC off indicator  illuminates to indicate the VDC system is off. When the VDC system is turned off, the VDC system still operates to prevent one drive wheel from slipping by transferring power to a non slipping drive wheel. The slip indicator light  flashes if this occurs. All other VDC functions are off, and the slip indicator light  will not flash. The VDC system is automatically reset to on when the ignition switch is placed in the off position then back to the on position.

See "Slip indicator light" (P.2-20) and "Vehicle Dynamic Control (VDC) off indicator light" (P.2-21).





The computer has a built-in diagnostic feature that tests the system each time you start the engine and move the vehicle forward or in reverse at a slow speed. When the self-test occurs, you may hear a “clunk” noise and/or feel a pulsation in the brake pedal. This is normal and is not an indication of a malfunction.



WARNING

- The VDC system is designed to help improve driving stability but does not prevent accidents due to abrupt steering operation at high speeds or by careless or dangerous driving techniques. Reduce vehicle speed and be especially careful when driving and cornering on slippery surfaces and always drive carefully.
- Do not modify the vehicle's suspension. If suspension parts such as shock absorbers, struts, springs, stabilizer bars, bushings and wheels are not NISSAN recommended for your vehicle or are extremely deteriorated, the VDC system may not operate properly. This could adversely affect vehicle handling performance, and the slip indicator light

 may illuminate.

- If brake related parts such as brake pads, rotors and calipers are not NISSAN recommended or are extremely deteriorated, the VDC system may not operate properly and the slip indicator light  may illuminate.
- If engine control related parts are not NISSAN recommended or are extremely deteriorated, the slip indicator light  may illuminate.
- When driving on extremely inclined surfaces such as higher banked corners, the VDC system may not operate properly and the slip indicator light  may illuminate. Do not drive on these types of roads.
- When driving on an unstable surface such as a turntable, ferry, elevator or ramp, the slip indicator light  may illuminate. This is not a malfunction. Restart the engine after driving onto a stable surface.
- If wheels or tires other than the NISSAN recommended ones are used, the VDC system may not operate properly and the slip indicator light  may illuminate.

- The VDC system is not a substitute for winter tires or tire chains on a snow covered road.

HOW TO TURN OFF THE VDC SYSTEM

The vehicle should be driven with the Vehicle Dynamic Control (VDC) system ON for most driving conditions.

When the vehicle is stuck in mud or snow, the VDC system reduces the engine output to reduce wheel spin. The engine speed will be reduced even if the accelerator is depressed to the floor. If maximum engine power is needed to free a stuck vehicle, turn the VDC system off.

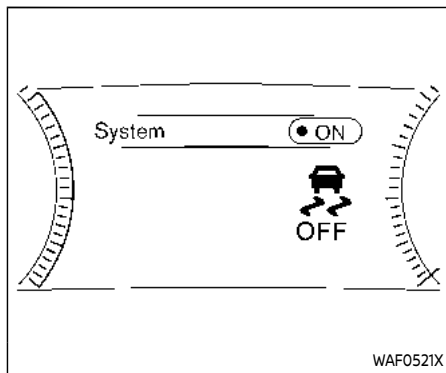

Example

To turn off the VDC system, perform the following steps in the vehicle information display.

1. Push the ◀ ▶ button on the steering wheel until "Settings" appears and then push the job dial.
2. Use the scroll dial to select "VDC Setting" and then push it.
3. Select "System" and push the scroll dial. The  indicator light will illuminate.













Turn "VDC Setting" back on in the vehicle information display or restart the engine to turn on the VDC system.



BRAKE FORCE DISTRIBUTION

During braking while driving through turns, the system optimizes the distribution of force to each of the four wheels depending on the radius of the turn.



WARNING

- The VDC system is designed to help the driver maintain stability but does not prevent accidents due to abrupt steering operation at high speeds or by careless or dangerous driving techniques. Reduce vehicle speed and be especially careful when driving and cornering on slippery surfaces and always drive carefully.
- Do not modify the vehicle's suspension. If suspension parts such as shock absorbers, struts, springs, stabilizer bars, bushings and wheels are not NISSAN recommended for your vehicle or are extremely deteriorated, the VDC system may not operate properly. This could adversely affect vehicle handling performance, and the  indicator light may flash or both the  and  indicator lights may illuminate.
- If brake related parts such as brake pads, rotors and calipers are not NISSAN recommended or are extremely deteriorated, the VDC system may not operate properly and both the  and  indicator lights may illuminate.
- If engine control related parts are not NISSAN recommended or are extremely deteriorated, both the  and  indicator lights may illuminate.
- When driving on extremely inclined surfaces such as higher banked corners, the VDC system may not operate properly and the  indicator light may flash or both the  and  indicator lights may illuminate. Do not drive on these types of roads.
- When driving on an unstable surface such as a turntable, ferry, elevator or ramp, the  indicator light may flash or both the  and  indicator lights may illuminate. This is not a malfunction. Restart the engine after driving onto a stable surface.
- If wheels or tires other than the NISSAN recommended ones are

used, the VDC system may not operate properly and the  indicator light may flash or both the  and  indicator lights may illuminate.

- The VDC system is not a substitute for winter tires or tire chains on a snow covered road.

CHASSIS CONTROL

The chassis control includes the following functions:

- Intelligent Trace Control
- Active Ride Control

INTELLIGENT TRACE CONTROL

This system senses driving based on the driver's steering and acceleration/braking patterns, and controls brake pressure at individual wheels to aid tracing at corners and promote smooth vehicle response.

The amount of brake control is changed based on the mode selected by the Drive Mode Selector. When the VDC system is turned off, Intelligent Trace Control is also turned off.

When Intelligent Trace Control is not functioning properly, the master warning light illuminates, and the warning message "Chassis Control System Error" will also appear in the vehicle information display.

If the chassis control warning message appears in the vehicle information display, it may indicate that Intelligent Trace Control is not functioning properly. Have the system checked as soon as possible. It is recommended that you visit a NISSAN dealer for this service. (See "Vehicle information display warnings and indicators" (P.2-35).)



WARNING

Intelligent Trace Control may not be effective depending on the driving condition. Always drive carefully and attentively.

When Intelligent Trace Control is operating, you may feel a pulsation in the brake pedal and hear a noise. This is normal and indicates that Intelligent Trace Control is operating properly. You may also feel deceleration when Intelligent Trace Control is operating. However, this is not a malfunction.

ACTIVE RIDE CONTROL

This system senses upper body motion and controls four wheel brake pressure. This will enhance ride comfort in an effort to restrain uncomfortable upper body movement when passing over undulated road surfaces. When the VDC system is turned off, Active Ride Control is also turned off.

If the chassis control warning message appears in the vehicle information display, it may indicate that Active Ride Control is not functioning properly. Have the system checked as soon as possible. It is recommended that you visit a NISSAN

dealer for this service.



WARNING

Active Ride Control may not be effective depending on the driving condition. Always drive carefully and attentively.

When Active Ride Control is operating, you may feel a pulsation in the brake pedal and hear a noise. This is normal and indicates that Active Ride Control is operating properly. You may also feel deceleration when Active Ride Control is operating. However, this is not a malfunction.

HILL START ASSIST SYSTEM



WARNING

- **Never rely solely on the hill start assist system to prevent the vehicle from moving backward on a hill. Always drive carefully and attentively. Depress the brake pedal when the vehicle is stopped on a steep hill. Be especially careful when stopped on a hill on frozen or muddy roads. Failure to prevent the vehicle from rolling backwards may result in a loss of control of the vehicle and possible serious injury or death.**
- **The hill start assist system is not designed to hold the vehicle at a standstill on a hill. Depress the brake pedal when the vehicle is stopped on a steep hill. Failure to do so may cause the vehicle to roll backwards and may result in a collision or serious personal injury.**
- **The hill start assist system may not prevent the vehicle from rolling backwards on a hill under all load or road conditions. Always be prepared to depress the brake pedal to prevent the vehicle from rolling backwards. Failure to do**

so may result in a collision or serious personal injury.

The hill start assist system automatically keeps the brakes applied to help prevent the vehicle from rolling backwards in the time it takes the driver to release the brake pedal and apply the accelerator when the vehicle is stopped on a hill.

The hill start assist system will operate automatically under the following conditions:

- The transmission is shifted to a forward or reverse gear.
- The vehicle is stopped completely on a hill by applying the brake.

The maximum holding time is 2 seconds. After 2 seconds the vehicle will begin to roll back and the hill start assist system will stop operating completely.

The hill start assist system will not operate when the transmission is shifted to the N (Neutral) or P (Park) position or on a flat and level road.

When the slip indicator light illuminates in the meter, the hill start assist system will not operate. (See "Slip indicator light" (P.2-20).)

SONAR SYSTEM (if so equipped)

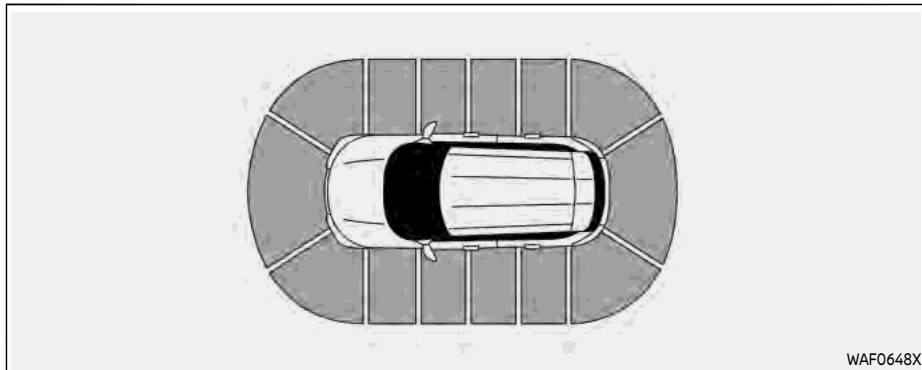

WAF0648X

Example

The sonar system sounds a tone to inform the driver of obstacles around the vehicle using the sonar sensors located in the front and rear bumpers.

When the sonar system is turned on, the sonar view will automatically appear in the vehicle information display.



WARNING

- The sonar system is a convenience but it is not a substitute for proper parking.

- The driver is always responsible for safety during parking and other maneuvers. Always look around and check that it is safe to do so before parking.
- Read and understand the limitations of the sonar system as contained in this section. The colors of the sonar indicator indicates different distances to the object.
- Inclement weather or ultrasonic sources such as an automatic car wash, a truck's compressed-air brakes or a pneumatic drill may

affect the function of the system; this may include reduced performance or a false activation.

- The sonar system is designed as an aid to the driver in detecting large stationary objects to help avoid damaging the vehicle.
- The sonar system is not designed to prevent contact with small or moving objects. Always move slowly. The system will not detect small objects below the bumper/vehicle side, and may not detect objects close to the bumper/vehicle side or on the ground.
- The sonar system may not detect the following objects: fluffy objects such as snow, cloth, cotton, glass-wool, etc.; thin objects such as rope, wire and chain, etc.; or wedge-shaped objects.

If your vehicle sustains damage to the bumper fascia, leaving it misaligned or bent, the sensing zone may be altered causing inaccurate measurement of obstacles or false alarms.

CAUTION

- Excessive noise (such as audio system volume or an open vehicle window) will interfere with the tone and it may not be heard.
- Keep the sonar sensors (located on the bumper fascia) free from snow, ice and large accumulations of dirt. Do not clean the sensors with sharp objects. If the sensors are covered, the accuracy of the sonar function will be diminished.

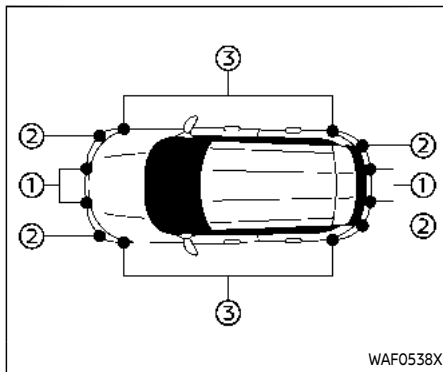

- ① Center sonar sensors
- ② Corner sonar sensors
- ③ Side sonar sensors (if so equipped)

SYSTEM OPERATION

For models without side sonar sensors:

The system informs with a visual and audible alert of:

- front obstacles when the shift lever is in the D (Drive) position
- front and rear obstacles when the shift lever is in the R (Reverse) position

For models with side sonar sensors:

The system provides a visual and audible alert of obstacles in the traveling direction, when the sensor detects them within its detection range.

The system can also provide a visual and audible alerts of potential obstacles near the side of the vehicle. The driver will only be notified of side obstacles located after the obstacles are first detected by the front or rear corner sensor. The system then predicts the obstacle path along the side of the vehicle as the vehicle moves.

How the system alert of obstacles:

The system is deactivated at speeds above 6 MPH (10 km/h). It is reactivated at lower speeds.

The intermittent tone will stop after several seconds when the obstacle is identified only with the center sensor. The tone will stop when the obstacle gets away from the vehicle.

When the object is detected, the indicator (green) appears and blinks and the tone sounds intermittently. When the vehicle moves closer to the object, the color of the indicator turns yellow and the rate of the blinking increases. When the vehicle is very close to the object, the indicator stops blinking and turns red, and the tone sounds continuously.

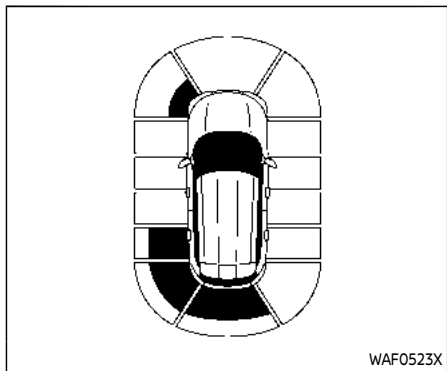

WAF0523X

Example

When the vehicle moves closer to an obstacle, the sonar indicator (detected area) appears in the vehicle information display.

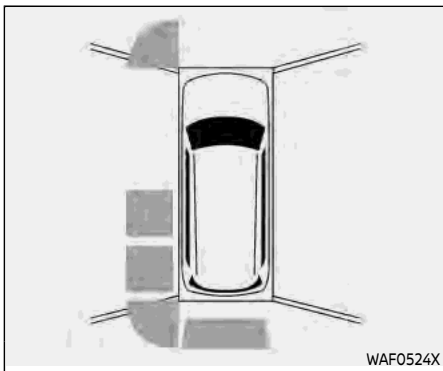

WAF0524X

Example

The sonar indicator also appears on the camera view of the center display.

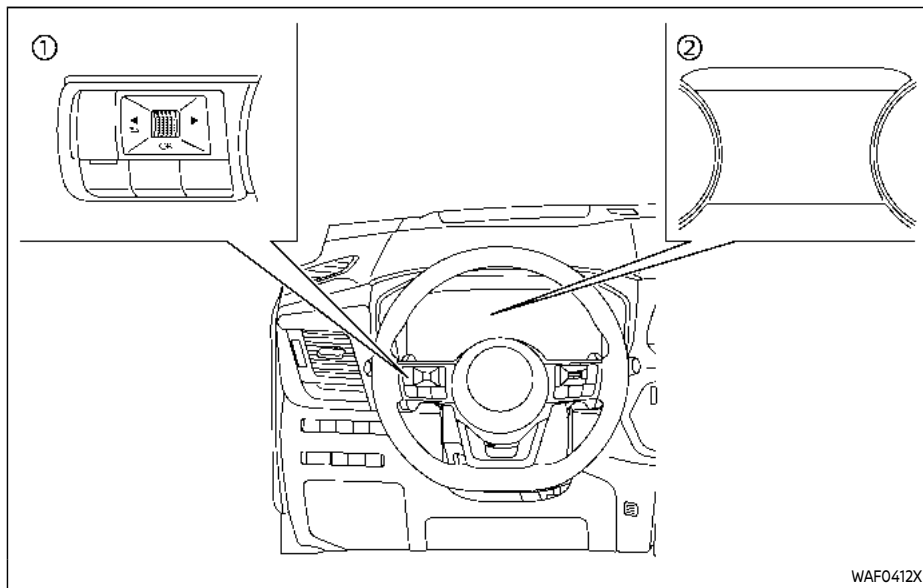

- ① Steering-wheel-mounted control (left side)
- ② Vehicle information display

HOW TO ENABLE/DISABLE THE SONAR SYSTEM

The system is automatically activated when the ignition switch is in the ON position and the shift lever is in the D (Drive) or R (Reverse) position.

Perform the following steps to set up the

sonar system function.

1. Push the ◀ ▶ button until "Settings" appears in the vehicle information display and then push the scroll dial. Use the scroll dial to select "Driver Assistance." Then push the scroll dial.
2. Select "Parking Assist" and push the scroll dial.
3. Use the scroll dial to navigate in the menu and select or change an item:
 - Moving Object
 - Turns ON/OFF the Moving Object Detection (MOD) (See "Moving Object Detection (MOD)" (P.4-22).)
 - Auto Show Sonar
 - Shows the sonar display in the vehicle information display when the sonar activates
 - Front Sonar
 - Turns ON/OFF the front sonar sensors
 - Rear Sonar
 - Turns ON/OFF the rear sonar sensors
 - Side Sonar (if so equipped)
 - Turns ON/OFF the side sonar sensors
 - Sonar Distance
 - Changes the sonar sensor's detection distance to "Long," "Med-

ium” or “Short”

- Sonar Volume
 - Changes the volume of the tone sound to “High,” “Medium” or “Low”

SONAR SYSTEM LIMITATIONS



WARNING

Listed below are the system limitations for the sonar system. Failure to operate the vehicle in accordance with these system limitations could result in serious injury or death.

- Read and understand the limitations of the sonar system as contained in this section. Inclement weather may affect the function of the sonar system; this may include reduced performance or a false activation.
- The sonar system is deactivated at speeds above 6 MPH (10 km/h). It is reactivated at lower speeds.
- Inclement weather or ultrasonic sources such as an automatic car wash, a truck’s compressed-air brakes or a pneumatic drill may affect the function of the sonar system; this may include reduced performance or a false activation.

- The sonar system is not designed to prevent contact with small or moving objects. Always move slowly. The system will not detect small objects below the bumper or on the ground.
- The sonar system may not detect the following objects: fluffy objects such as snow, cloth, cotton, glass-wool, etc.; thin objects such as rope, wire and chain, etc.; or wedge-shaped objects; complex-shaped objects or multiple objects in close.
- The sonar system may not detect objects at speed above 3 MPH (5 km/h) and may not detect certain angular or moving objects.
- The sonar system may not detect pedestrians including small children and animals.
- The side sonar may not detect the following objects:
 - Objects on the side of the vehicle that were not first detected by the front or rear corner sensor.
- The sonar system may not operate in the following conditions:

- When rain, snow, ice, dirt, etc. adheres to the sonar sensor.
- When a loud sound is heard in the area around the vehicle.
- When the surface of the obstacle is diagonal to the front or rear of the vehicle.
- When a sonar sensor or the area around the sensor is extremely hot or cold.
- The sonar system may unintentionally operate in the following conditions:
 - When there is overgrown grass in the area around the vehicle.
 - When there is a structure (for example, a wall, a toll gate equipment, a narrow tunnel or a parking lot gate) near the side of the vehicle.
 - When there are bumps, protrusions or manhole covers on the road surface.
 - When the vehicle drives through a draped flag or a curtain.

– When there is an accumulation of snow or ice behind the vehicle.

– When driving on a steep hill.

SYSTEM TEMPORARILY UNAVAILABLE

When sonar blockage is detected, the system will be deactivated automatically. The system is not available until the conditions no longer exist.

The sonar sensors may be blocked by temporary ambient conditions such as splashing water, mist or fog. The blocked condition may also be caused by objects such as ice, frost or dirt obstructing the sonar sensors.

Action to take:

When the above conditions no longer exist, the system will resume automatically.

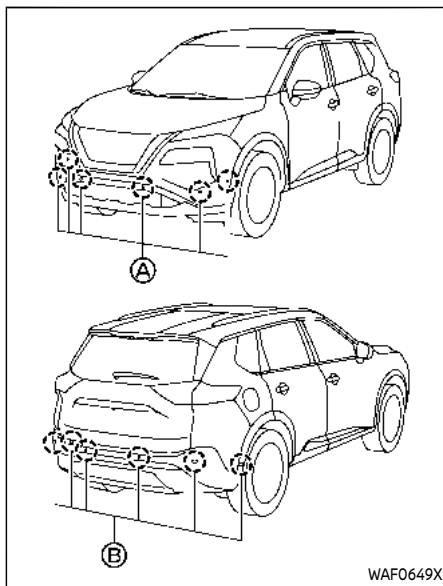

SYSTEM MAINTENANCE

The sonar sensors (A) and (B) are located on the front and rear bumpers.

- Always keep the area near the sonar sensors clean.
- If the sonar sensors are dirty, wipe them off with a soft cloth while being

careful to not damage them.

- The sonar sensors may be blocked by temporary ambient conditions such as splashing water, mist or fog. The blocked condition may also be caused by objects such as ice, frost or dirt obstructing the sonar sensors. Check for and remove objects obstructing the area around the sonar sensors.
- Do not subject the area around the sonar sensors to strong impact. Also, do not remove or disassemble the sonar sensors. If the sonar sensors and peripheral areas are deformed in an accident, etc., have the sonar sensors checked. It is recommended that you visit a NISSAN dealer for this service.
- Do not attach stickers (including transparent material), install accessories or apply additional paint on the sonar sensors and their surrounding areas. This may cause a malfunction or improper operation.
- When washing the vehicle using a high-pressure washer, do not apply direct washer pressure on the sonar sensors. This may cause a malfunction of the sonar sensors.

REAR SONAR SYSTEM (RSS) (if so equipped)

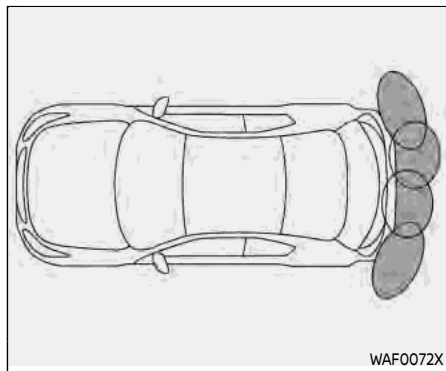

The RSS sounds a tone to inform the driver of obstacles near the rear bumper.

When the RSS is turned on, the sonar view will automatically appear in the vehicle information display.

WARNING

- The RSS is a convenience but it is not a substitute for proper parking.
- The driver is always responsible for safety during parking and other maneuvers. Always look around and check that it is safe

to do so before parking.

- Read and understand the limitations of the RSS as contained in this section. The colors of the sonar indicator indicates different distances to the object.
- Inclement weather or ultrasonic sources such as an automatic car wash, a truck's compressed-air brakes or a pneumatic drill may affect the function of the system; this may include reduced performance or a false activation.
- The RSS is designed as an aid to the driver in detecting large stationary objects to help avoid damaging the vehicle.
- The RSS is not designed to prevent contact with small or moving objects. Always move slowly. The system will not detect small objects below the bumper, and may not detect objects close to the bumper or on the ground.
- The RSS may not detect the following objects: fluffy objects such as snow, cloth, cotton, glass-wool, etc.; thin objects such as rope, wire and chain, etc.; or wedge-shaped objects.

If your vehicle sustains damage to the bumper fascia, leaving it misaligned or bent, the sensing zone may be altered causing inaccurate measurement of obstacles or false alarms.

CAUTION

- Excessive noise (such as audio system volume or an open vehicle window) will interfere with the tone and it may not be heard.
- Keep the sonar sensors (located on the rear bumper fascia) free from snow, ice and large accumulations of dirt. Do not clean the sensors with sharp objects. If the sensors are covered, the accuracy of the sonar function will be diminished.

SYSTEM OPERATION

The system informs with a visual and audible alert of rear obstacles when the shift lever is in the R (Reverse) position.

The system is deactivated at speeds above 6 MPH (10 km/h). It is reactivated at lower speeds.

The intermittent tone will stop after several seconds when an obstacle is

identified only with the corner sensor. The tone will stop when the obstacle gets away from the vehicle.

When the object is detected, the indicator (green) appears and blinks and the tone sounds intermittently. When the vehicle moves closer to the object, the color of the indicator turns yellow and the rate of the blinking increases. When the vehicle is very close to the object, the indicator stops blinking and turns red, and the tone sounds continuously.

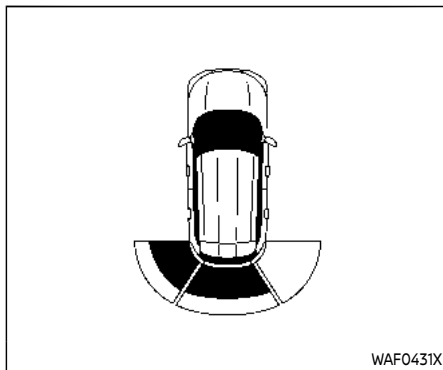

Example

When the rear of the vehicle moves closer to an obstacle, the sonar indicator appears in the vehicle information display.

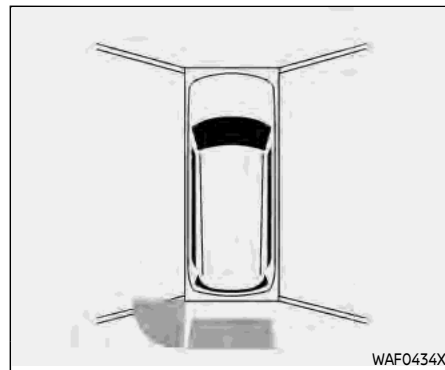

Example

The sonar indicator also appears on the camera view of the center display.

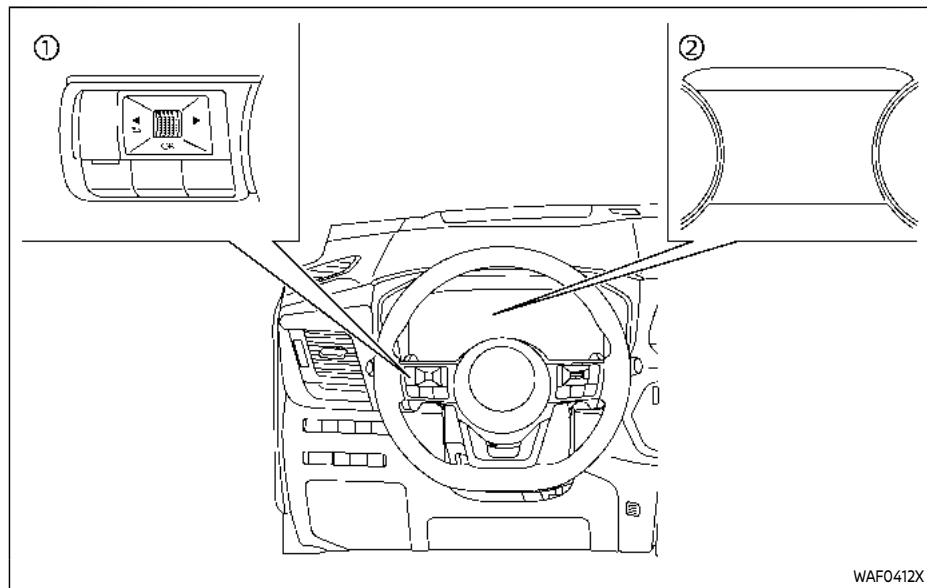

- ① Steering-wheel-mounted control (left side)
- ② Vehicle information display

HOW TO ENABLE/DISABLE THE RSS

The system is automatically activated when the ignition switch is in the ON position and the shift lever is in the R (Reverse) position.

Perform the following steps to set up the RSS function:

1. Push the ◀ ▶ button until "Settings" appears in the vehicle information display and then push the scroll dial. Use the scroll dial to select "Driver Assistance." Then push the scroll dial.
2. Select "Parking Assist" and push the scroll dial.
3. Use the scroll dial to navigate in the menu and select or change an item:
 - Moving Object (if so equipped)
 - Turns ON/OFF the Moving Object Detection (MOD) (See "Moving Object Detection (MOD)" (P.4-22).)
 - Auto Show Sonar
 - Shows the sonar display in the vehicle information display when the RSS activates
 - Rear Sonar
 - Turns ON/OFF the RSS
 - Sonar Distance
 - Changes the RSS sensor's detection distance to "Long," "Medium" or "Short"
 - Sonar Volume
 - Changes the volume of the tone sound to "High," "Medium" or "Low"

RSS LIMITATIONS



WARNING

Listed below are the system limitations for the RSS. Failure to operate the vehicle in accordance with these system limitations could result in serious injury or death.

- Read and understand the limitations of the RSS as contained in this section. Inclement weather may affect the function of the RSS; this may include reduced performance or a false activation.
- The system is deactivated at speeds above 6 MPH (10 km/h). It is reactivated at lower speeds.
- Inclement weather or ultrasonic sources such as an automatic car wash, a truck's compressed-air brakes or a pneumatic drill may affect the function of the RSS; this may include reduced performance or a false activation.
- The RSS is not designed to prevent contact with small or moving objects. Always move slowly. The system will not detect small objects below the bumper or on the ground.

- The RSS may not detect the following objects: fluffy objects such as snow, cloth, cotton, glass-wool, etc.; thin objects such as rope, wire and chain, etc.; or wedge-shaped objects; complex-shaped objects or multiple objects in close.
- The RSS may not detect objects at speed above 3 MPH (5 km/h) and may not detect certain angular or moving objects.
- The RSS may not detect pedestrians including small children and animals.
- The RSS may not operate in the following conditions:
 - When rain, snow, ice, dirt, etc. adheres to the sonar sensor.
 - When a loud sound is heard in the area around the vehicle.
 - When the surface of the obstacle is diagonal to the rear of the vehicle.
 - When a sonar sensor or the area around the sensor is extremely hot or cold.
- The RSS may unintentionally operate in the following conditions:

- When there is overgrown grass in the area around the vehicle.
- When there are bumps, protrusions or manhole covers on the road surface.
- When the vehicle drives through a draped flag or a curtain.
- When there is an accumulation of snow or ice behind the vehicle.
- When driving on a steep hill.

SYSTEM TEMPORARILY UNAVAILABLE

When sonar blockage is detected, the system will be deactivated automatically. The system is not available until the conditions no longer exist.

The sonar sensors may be blocked by temporary ambient conditions such as splashing water, mist or fog. The blocked condition may also be caused by objects such as ice, frost or dirt obstructing the sonar sensors.

Action to take:

When the above conditions no longer exist, the system will resume automatically.

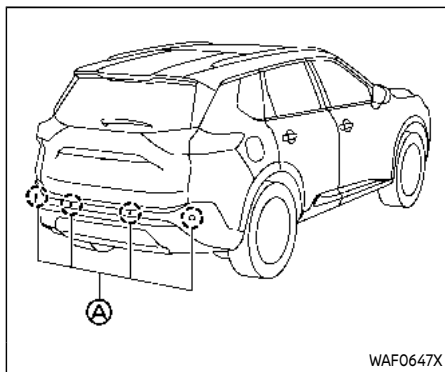
**SYSTEM MAINTENANCE**

The sonar sensors (A) are located on the rear bumper.

- Always keep the area near the sonar sensors clean.
- If the sonar sensors are dirty, wipe them off with a soft cloth while being careful to not damage them.
- The sonar sensors may be blocked by temporary ambient conditions such as splashing water, mist or fog. The blocked condition may also be caused by objects such as ice, frost or dirt obstructing the sonar sensors. Check for and remove objects obstructing the area around the sonar sensors.

- Do not subject the area around the sonar sensors to strong impact. Also, do not remove or disassemble the sonar sensors. If the sonar sensors and peripheral areas are deformed in an accident, etc., have the sonar sensors checked. It is recommended that you visit a NISSAN dealer for this service.
- Do not attach stickers (including transparent material), install accessories or apply additional paint on the sonar sensors and their surrounding areas. This may cause a malfunction or improper operation.
- When washing the vehicle using a high-pressure washer, do not apply direct washer pressure on the sonar sensors. This may cause a malfunction of the sonar sensors.

COLD WEATHER DRIVING

FREEING A FROZEN DOOR LOCK

To prevent a door lock from freezing, apply deicer through the key hole. If the lock becomes frozen, heat the key before inserting it into the key hole, or use the Intelligent Key system.

ANTI-FREEZE

In the winter when it is anticipated that the outside temperature will drop below 32°F (0°C), check the anti-freeze to assure proper winter protection. For additional information, see "Engine cooling system" (P.8-4) or "Intercooler cooling system" (P.8-6).

BATTERY

If the battery is not fully charged during extremely cold weather conditions, the battery fluid may freeze and damage the battery. To maintain maximum efficiency, the battery should be checked regularly. For additional information, see "Battery" (P.8-14).

DRAINING OF COOLANT WATER

If the vehicle is to be left outside without anti-freeze, drain the cooling system, including the engine block. Refill before operating the vehicle. For details, see "Engine cooling system" (P.8-4).

TIRE EQUIPMENT

SUMMER tires have a tread designed to provide superior performance on dry pavement. However, the performance of these tires will be substantially reduced in snowy and icy conditions. If you operate your vehicle on snowy or icy roads, NISSAN recommends the use of MUD & SNOW or ALL SEASON tires on all four wheels. It is recommended you consult a NISSAN dealer for the tire type, size, speed rating and availability information.

For additional traction on icy roads, studded tires may be used. However, some U.S. states and Canadian provinces prohibit their use. Check local, state and provincial laws before installing studded tires.

Skid and traction capabilities of studded snow tires, on wet or dry surfaces, may be poorer than that of non-studded snow tires.

Tire chains may be used. For details, see "Tire chains" (P.8-37) of this manual.

All-Wheel Drive (AWD) model

If you install snow tires, they must also be the same size, brand, construction and tread pattern on all four wheels.

SPECIAL WINTER EQUIPMENT

It is recommended that the following items be carried in the vehicle during winter:

- A scraper and stiff-bristled brush to remove ice and snow from the windows and wiper blades.
- A sturdy, flat board to be placed under the jack to give it firm support.
- A shovel to dig the vehicle out of snow-drifts.
- Extra window washer fluid to refill the reservoir tank.

DRIVING ON SNOW OR ICE



WARNING

- **Wet ice (32°F, 0°C and freezing rain), very cold snow or ice can be slick and very hard to drive on. The vehicle will have much less traction or "grip" under these conditions. Try to avoid driving on wet ice until the road is salted or sanded.**

ACTIVE NOISE CANCELLATION (if so equipped)/ACTIVE SOUND ENHANCEMENT (if so equipped)

- Whatever the condition, drive with caution. Accelerate and slow down with care. If accelerating or downshifting too fast, the drive wheels will lose even more traction.
- Allow more stopping distance under these conditions. Braking should be started sooner than on dry pavement.
- Allow greater following distances on slippery roads.
- Watch for slippery spots (glare ice). These may appear on an otherwise clear road in shaded areas. If a patch of ice is seen ahead, brake before reaching it. Try not to brake while on the ice, and avoid any sudden steering maneuvers.
- Do not use cruise control on slippery roads.
- Snow can trap dangerous exhaust gases under your vehicle. Keep snow clear of the exhaust pipe and from around your vehicle.

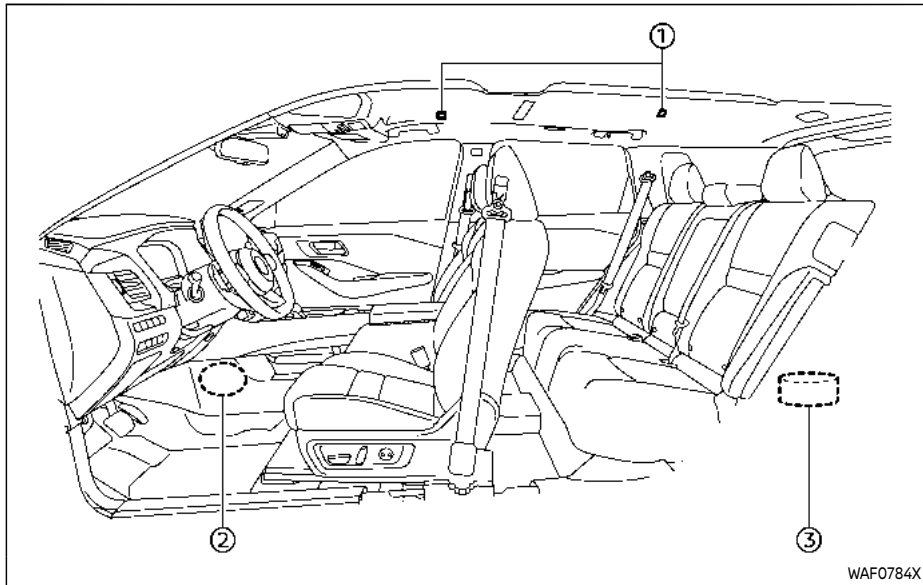

NOTE:

To operate the active noise cancellation and active sound enhancement system properly:

- Do not cover the speakers or woofer.
- Do not cover the microphones.

- Do not change or modify speakers including the woofer and any audio related parts such as the amplifier.
- Do not make any modification including sound deadening or modifications around the microphones, speakers or woofer.

ACTIVE NOISE CANCELLATION

The active noise cancellation uses microphones ① located inside the vehicle to detect engine booming noises. The system then automatically produces a muted engine booming noise through the speakers ② and woofer ③ to reduce engine booming noise.

If the microphones ① or the area around it is tapped, abnormal noise may be output from the speaker.

ACTIVE SOUND ENHANCEMENT

The active sound enhancement generates sounds according to engine speed and driving modes through the speakers ② and woofer ③ to enhance the quality of the engine sound.

MEMO

6 In case of emergency

Hazard warning flasher switch	6-2	Jump starting	6-11
Connection to Roadside Assistance	6-2	Push starting	6-14
Emergency engine shut off	6-3	If your vehicle overheats	6-14
Flat tire	6-3	Towing your vehicle	6-15
Tire Pressure Monitoring System (TPMS)	6-3	Towing recommended by NISSAN	6-16
Changing a flat tire	6-4	Vehicle recovery (freeing a stuck vehicle)	6-17

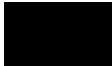

HAZARD WARNING FLASHER SWITCH

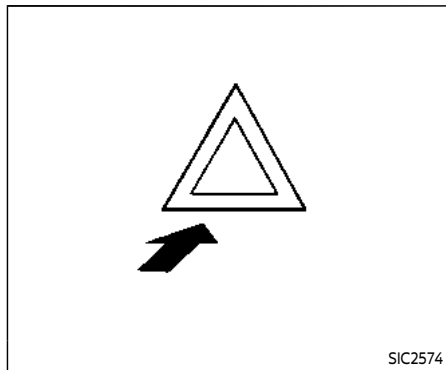

Push the switch on to warn other drivers when you must stop or park under emergency conditions. All turn signal lights will flash.



WARNING

- If stopping for an emergency, be sure to move the vehicle well off the road.
- Do not use the hazard warning flashers while moving on the highway unless unusual circumstances force you to drive so slowly that your vehicle might become a hazard to other traffic.

6-2 In case of emergency

CONNECTION TO ROADSIDE ASSISTANCE

In the event of a roadside emergency, Roadside Assistance Service is available to you. Please refer to your Warranty Information Booklet (U.S.) or Warranty & Roadside Assistance Information Booklet (Canada) for details.

- Turn signals do not work when the hazard warning flasher lights are on.

The flasher can be actuated with the ignition switch in any position.

Some state laws may prohibit the use of the hazard warning flasher switch while driving.

EMERGENCY ENGINE SHUT OFF

To shut off the engine in an emergency situation while driving, perform the following procedure:

- Rapidly push the push-button ignition switch 3 consecutive times in less than 1.5 seconds, or
- Push and hold the push-button ignition switch for more than 2 seconds.

FLAT TIRE

TIRE PRESSURE MONITORING SYSTEM (TPMS)

This vehicle is equipped with the Tire Pressure Monitoring System (TPMS). It monitors tire pressure of all tires except the spare. When the low tire pressure warning light is lit, and the "Tire Pressure Low - Add Air" warning message is displayed in the vehicle information display, one or more of your tires is significantly under-inflated. If the vehicle is being driven with low tire pressure, the TPMS will activate and warn you of it by the low tire pressure warning light. This system will activate only when the vehicle is driven at speeds above 16 MPH (25 km/h). For more details, see "Warning lights, indicator lights and audible reminders" (P.2-13) and "Tire Pressure Monitoring System (TPMS)" (P.5-6).



WARNING

- **If the low tire pressure warning light illuminates while driving, avoid sudden steering maneuvers or abrupt braking, reduce vehicle speed, pull off the road to a safe location and stop the vehicle as soon as possible. Driving with under-inflated tires may permanently damage the tires**

and increase the likelihood of tire failure. Serious vehicle damage could occur and may lead to an accident and could result in serious personal injury. Check the tire pressure for all four tires. Adjust the tire pressure to the recommended COLD tire pressure shown on the Tire and Loading Information label to turn the low tire pressure warning light OFF. If the light still illuminates while driving after adjusting the tire pressure, a tire may be flat. If you have a flat tire, replace it with a spare tire as soon as possible.

- **Since the spare tire is not equipped with the TPMS, when a spare tire is mounted or a wheel is replaced, the TPMS will not function and the low tire pressure warning light will flash for approximately 1 minute. The light will remain on after 1 minute. Have your tires replaced and/or TPMS system reset as soon as possible. It is recommended you visit a NISSAN dealer for these services.**
- **Replacing tires with those not originally specified by NISSAN could affect the proper operation**

of the TPMS.

- Do not inject any tire liquid or aerosol tire sealant into the tires, as this may cause a malfunction of the tire pressure sensors.

CHANGING A FLAT TIRE

If you have a flat tire, follow the instructions below.

Stopping the vehicle

1. Safely move the vehicle off the road and away from traffic.
2. Turn on the hazard warning flashers.
3. Park on a level surface and apply the parking brake.
4. Push the park button to engage the P (Park) position.
5. Turn off the engine.
6. Raise the hood to warn other traffic, and to signal professional road assistance personnel that you need assistance.
7. Have all passengers get out of the vehicle and stand in a safe place, away from traffic and clear of the vehicle.



WARNING

- Make sure the parking brake is securely applied and the shift position is placed in the P (Park) position.
- Never change tires when the vehicle is on a slope, ice or slippery areas. This is hazardous.
- Never change tires if oncoming traffic is close to your vehicle. Wait for professional road assistance.

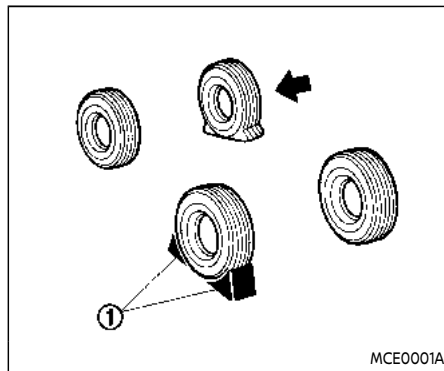

MCE0001A

Blocking wheels

Place suitable blocks ① at both the front and back of the wheel diagonally opposite the flat tire to prevent the vehicle from moving when it is jacked up.



WARNING

Be sure to block the wheel as the vehicle may move and result in personal injury.

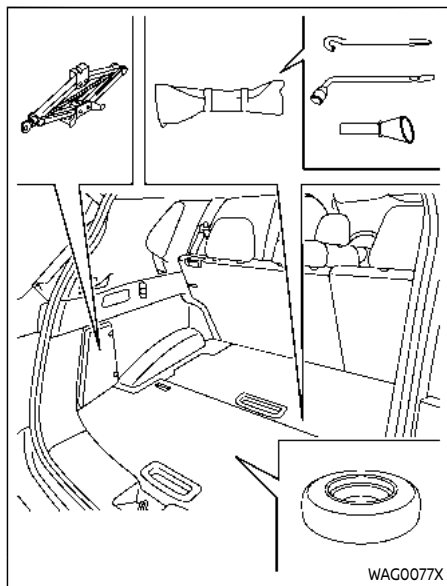

Models with adjustable luggage floor

Getting the spare tire and tools

The jack, jacking tools and the spare tire are stored in the storage in the luggage area.

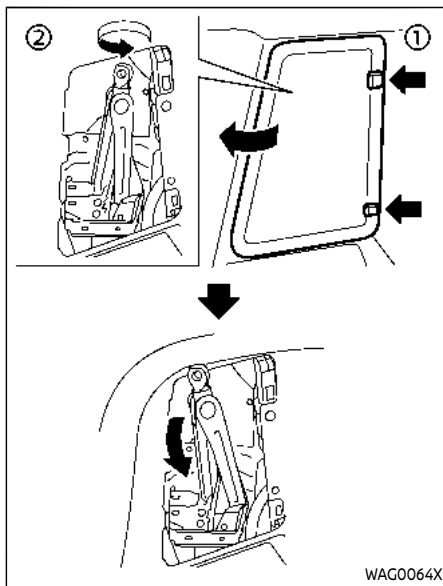

To remove the jack:

1. Remove the storage door by pressing the two release tabs simultaneously.
2. Turn the jack lever in a counter-clockwise direction, and then remove the jack slowly.

When storing the jack, set the jack slowly

back, then turn the jack lever in a clockwise direction until the jack is fixed.

CAUTION

When removing the jack, be careful that your hands do not hit against the vehicle. Otherwise, this could result in personal injury.

NOTE:

- When storing the jack, do not over-tighten the jack lever using a screw driver. Doing so could cause deformation of the installation area for the jack.
- Do not allow the jack to contact the interior parts. Doing so could cause damage to the vehicle.

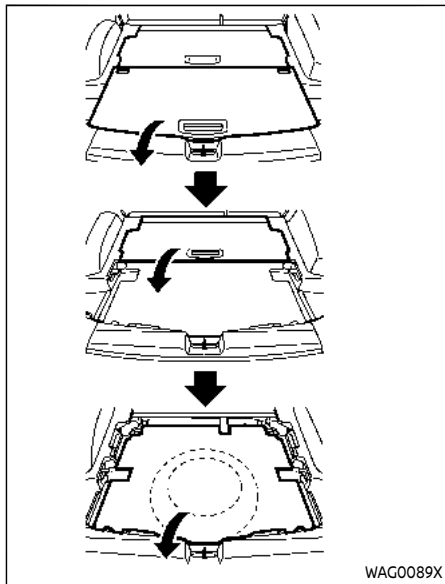

Models with adjustable luggage floor

Removing the spare tire and tools

The spare tire and tools are located under the luggage board(s).

To access the storage area:

1. Remove the luggage floorboard(s).

Models with the adjustable luggage

floor: Release the locks before removing the rear (outer) luggage board. (See "Adjustable luggage floor" (P.2-76) for details.)

Models with the single luggage board: Disengage the retainer pins. (See "Single luggage board" (P.2-76).)

2. Remove the floor carpet (if so equipped).

Remove the tools from the tool bag located in the storage area.

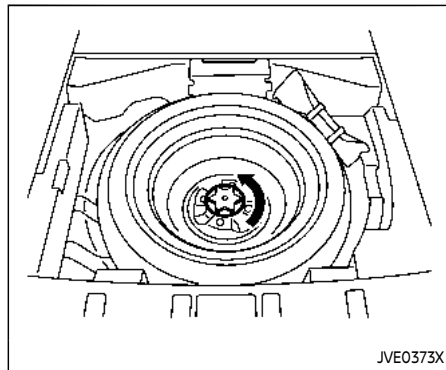

Remove the spare tire by removing the clamp holding it.

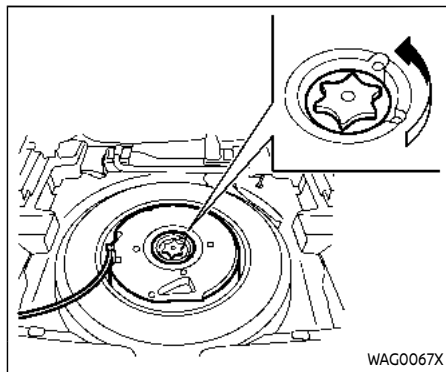

Example

Removing the spare tire with sub-woofer (if so equipped)

1. To loosen the bolt, turn counterclockwise.
2. Once loosened, remove the bolt.

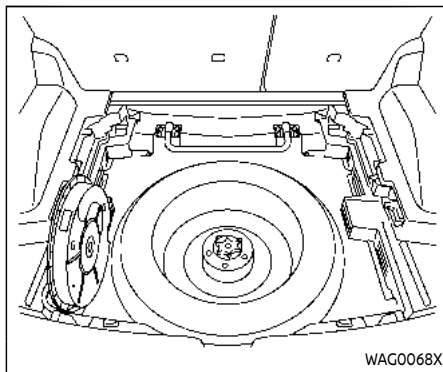

Example

3. Place the sub-woofer in the left corner of the cargo space.
4. Remove the spare tire.
5. Once the flat tire is exchanged with the spare tire, store the flat tire where the spare was located.
6. Place the sub-woofer inside the flat tire.
7. Turn the bolt clockwise to tighten.

Jacking up the vehicle and removing the damaged tire



WARNING

- Never get under the vehicle while it is supported only by the jack. If it is necessary to work under the vehicle, support it with safety stands.
- Use only the jack provided with your vehicle to lift the vehicle. Do not use the jack provided with your vehicle on other vehicles. The jack is designed for lifting only your vehicle during a tire change.
- Use the correct jack-up points. Never use any other part of the vehicle for jack support.
- Never jack up the vehicle more than necessary.
- Never use blocks on or under the jack.
- Do not start or run the engine while vehicle is on the jack, as it may cause the vehicle to move.
- Do not allow passengers to stay in the vehicle while it is on the

jack.

Carefully read the caution label attached to the jack body and the following instructions.

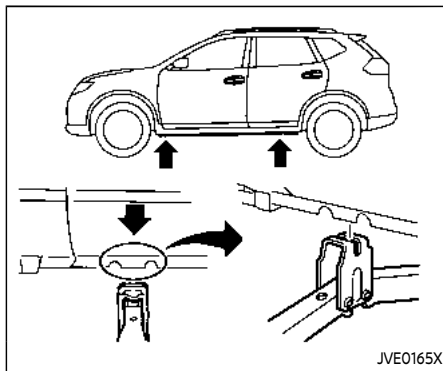

Jack-up point

1. Place the jack directly under the jack-up point as illustrated so the top of the jack contacts the vehicle at the jack-up point. Align the jack head between the two notches in the front or the rear as shown. Also fit the groove of the jack head between the notches as shown.

The jack should be used on firm and level ground.

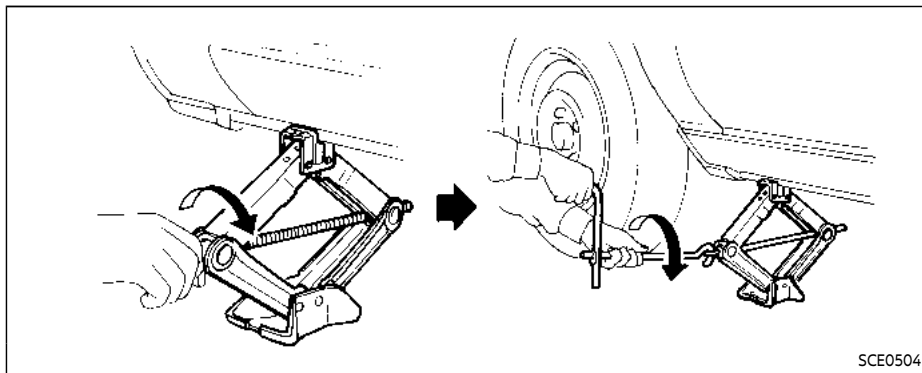

2. Loosen each wheel nut one or two turns by turning it counterclockwise with the wheel nut wrench. **Do not remove the wheel nuts until the tire is off the ground.**
3. To lift the vehicle, securely hold the jack lever and rod with both hands as shown above. Carefully raise the vehicle until the tire clears the ground. Remove the wheel nuts, and then remove the tire.

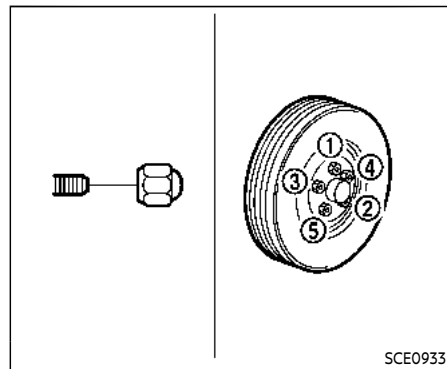

Installing the spare tire

The spare tire is designed for emergency use. (See specific instructions under the heading "Wheels and tires" (P.8-30).)

1. Clean any mud or dirt from the surface between the wheel and hub.
2. Carefully put the spare tire on and tighten the wheel nuts finger tight. Check that all the wheel nuts contact the wheel surface horizontally.
3. With the wheel nut wrench, tighten wheel nuts alternately and evenly in the sequence illustrated (1, 2, 3, 4, 5), more than 2 times, until they are tight.

4. Lower the vehicle slowly until the tire touches the ground. Then, with the wheel nut wrench, tighten the wheel nuts securely in the sequence illustrated. Lower the vehicle completely.



WARNING

- **Incorrect wheel nuts or improperly tightened wheel nuts can cause the wheel to become loose or come off. This could cause an accident.**
 - **Do not use oil or grease on the wheel studs or nuts. This could cause the nuts to become loose.**
 - **Retighten the wheel nuts when the vehicle has been driven for 600 miles (1,000 km) (also in cases of a flat tire, etc.).**
 - **As soon as possible, tighten the wheel nuts to the specified torque with a torque wrench.**
- Wheel nut tightening torque:
83 ft-lb (113 N-m)**
- The wheel nuts must be kept tightened to specifications at all times. It is recommended that the wheel nuts be tightened to specifications at**

each lubrication interval.

- **Adjust tire pressure to the COLD pressure.**

COLD pressure:

After the vehicle has been parked for 3 hours or more or driven less than 1 mile (1.6 km).

COLD tire pressures are shown on the Tire and Loading Information label affixed to the driver side center pillar.

Stowing the damaged tire and the tools

1. Securely store the jack, tools and the damaged tire in the storage area.
2. Replace the luggage boards and cover.
3. Close the liftgate.



WARNING

- **Always make sure that the spare tire and jacking equipment are properly secured after use. Such items can become dangerous projectiles in an accident or sudden stop.**

- **The spare tire is designed for emergency use. See specific instructions under the heading "Wheels and tires" (P.8-30).**

JUMP STARTING

To start your engine with a booster battery, the instructions and precautions below must be followed.



WARNING

- If done incorrectly, jump starting can lead to a battery explosion, resulting in severe injury or death. It could also damage your vehicle.
 - Explosive hydrogen gas is always present in the vicinity of the battery. Keep all sparks and flames away from the battery.
 - Do not allow battery fluid to come into contact with eyes, skin, clothing or painted surfaces. Battery fluid is a corrosive sulfuric acid solution which can cause severe burns. If the fluid should come into contact with anything, immediately flush the contacted area with water.
 - Keep the battery out of the reach of children.
 - The booster battery must be rated at 12 volts. Use of an improperly rated battery can damage your vehicle.
- Whenever working on or near a battery, always wear suitable eye protectors (for example, goggles or industrial safety spectacles) and remove rings, metal bands, or any other jewelry. Do not lean over the battery when jump starting.
 - Do not attempt to jump start a frozen battery. It could explode and cause serious injury.
 - Your vehicle has an automatic engine cooling fan. It could come on at any time. Keep hands and other objects away from it.

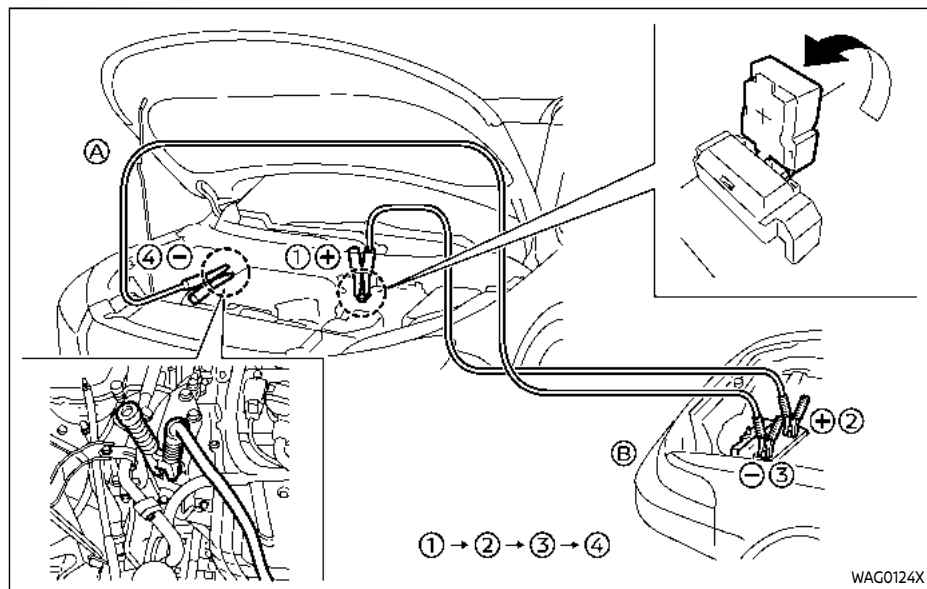

PR25DD engine

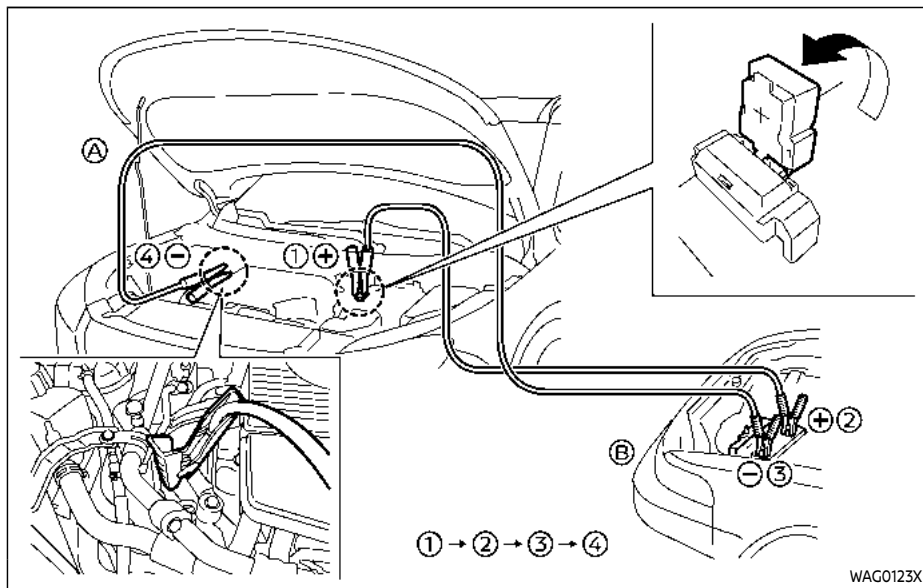

KR15DDT engine

WAG0123X



WARNING

Always follow the instructions below. Failure to do so could result in damage to the charging system and cause personal injury.

1. If the booster battery is in another vehicle ⑥, position the two vehicles (④ and ⑥) to bring their batteries into close proximity to each other.

Do not allow the two vehicles to touch.

2. Apply the parking brake.
3. Push the park button to engage the P (Park) position.
4. Switch off all unnecessary electrical systems (headlights, heater, air conditioner, etc.).
5. Connect jumper cables in the sequence as illustrated (① → ② → ③ → ④).



CAUTION

- Always connect positive (+) to positive (+) and negative (-) to body ground (for example, as illustrated), not to the battery.
- Make sure the jumper cables do not touch moving parts in the engine compartment and that the cable clamps do not contact any other metal.

6. Start the engine of the booster vehicle ⑥ and let it run for a few minutes.
7. Keep the engine speed of the booster vehicle ⑥ at about 2,000 rpm, and start the engine of the vehicle ④ being jump started.



CAUTION

Do not keep the starter motor engaged for more than 10 seconds. If the engine does not start right away, place the ignition switch in the OFF position and wait 10 seconds before trying again.

- After starting your engine, carefully disconnect the negative cable and then the positive cable (④ → ③ → ② → ①).

PUSH STARTING

Do not attempt to start the engine by pushing.



CAUTION

- Continuously Variable Transmission (CVT) models cannot be push-started or tow-started. Attempting to do so may cause transmission damage.
- Three-way catalyst equipped models should not be started by pushing since the three way catalyst may be damaged.
- Never try to start the vehicle by towing it; when the engine starts, the forward surge could cause the vehicle to collide with the tow vehicle.

IF YOUR VEHICLE OVERHEATS



WARNING

- Never continue driving if your vehicle overheats. Doing so could cause a vehicle fire.
- Never open the hood if steam is coming out.
- Never remove the radiator or coolant reservoir cap while the engine is hot. If the radiator or coolant reservoir cap is removed when the engine is hot, pressurized hot water will spurt out and possibly cause burning, scalding or serious injury.
- If steam or coolant is coming from the engine, stand clear of the vehicle to prevent getting burned.
- The engine cooling fan will start at anytime when the coolant temperature exceeds preset degrees.
- Be careful not to allow your hands, hair, jewelry or clothing to come into contact with, or to get caught in the cooling fan or drive belts.

If your vehicle is overheating (indicated by

an extremely high temperature gauge reading), or if you feel a lack of engine power, detect abnormal noise, etc., take the following steps:

1. Move the vehicle safely off the road and apply the parking brake.
2. Push the park button to shift to the P (Park) position.

Do not stop the engine.

3. Turn off the air conditioner (if so equipped). Open all the windows, move the heater or air conditioner temperature control to maximum hot and fan control to high speed.
4. Get out of the vehicle. Look and listen for steam or coolant escaping from the radiator or coolant reservoir before opening the hood. (If steam or coolant is escaping, turn off the engine.) Do not open the hood further until no steam or coolant can be seen.
5. Open the engine hood.



WARNING

If steam or water is coming from the engine, stand clear to prevent getting burned.

6. Visually check the drive belt for damage or looseness. Also check if the cooling fan is running. The radiator hoses and radiator should not leak water. If coolant is leaking or the cooling fan does not run, stop the engine.



WARNING

Be careful not to allow your hands, hair, jewelry or clothing to come into contact with, or get caught in, engine belts or the engine cooling fan. The engine cooling fan can start at any time.

7. After the engine cools down, check the coolant level in the reservoir with the engine running. Add coolant to the reservoir if necessary. Have your vehicle repaired. It is recommended you visit a NISSAN dealer for this service.

TOWING YOUR VEHICLE

When towing your vehicle, all jurisdictional and local regulations for towing must be followed. Incorrect towing equipment could damage your vehicle. Towing instructions are available from a NISSAN dealer. Local service operators are generally familiar with the applicable laws and procedures for towing. To assure proper towing and to prevent accidental damage to your vehicle, NISSAN recommends that you have a service operator tow your vehicle. It is advisable to have the service operator carefully read the following precautions.



WARNING

- **Never ride in a vehicle that is being towed.**
- **Never get under your vehicle after it has been lifted by a tow truck.**



CAUTION

- **When towing, make sure that the transmission, axles, steering system and powertrain are in working condition. If any of these conditions apply, dollies or a flatbed tow truck must be used.**

- **Always attach safety chains before towing.**

(See “Flat towing for All-Wheel Drive vehicle” (P.10-28) or “Flat towing for Front-Wheel Drive vehicle” (P.10-28).)

NOTE:

If the battery is completely drained, the transmission will not manually shift to other positions. For shifting to other positions, charge the battery or supply power following the jump starting procedure. Push the park button to shift to the P (Park) position before shifting to other positions.

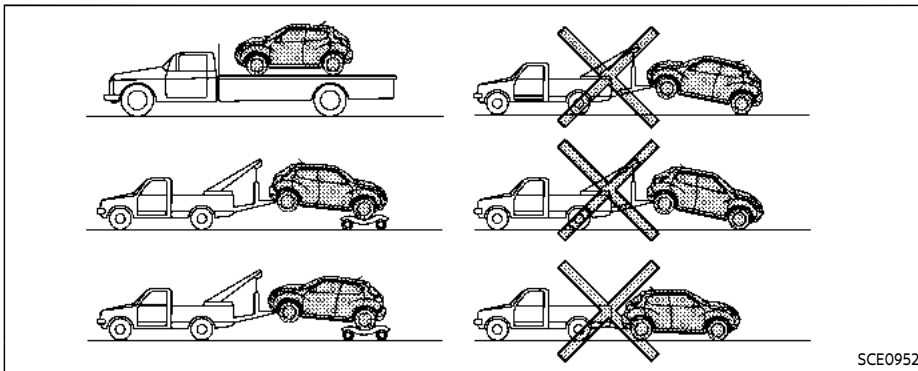

TOWING RECOMMENDED BY NISSAN

All-Wheel Drive (AWD) models

NISSAN recommends that towing dollies be used when towing your vehicle or the vehicle be placed on a flat bed truck as illustrated.

extensive damage to the transfer case and transmission.

⚠ CAUTION

Never tow All-Wheel Drive (AWD) models equipped with a Continuously Variable Transmission (CVT) with any of the wheels on the ground as this may cause serious and ex-

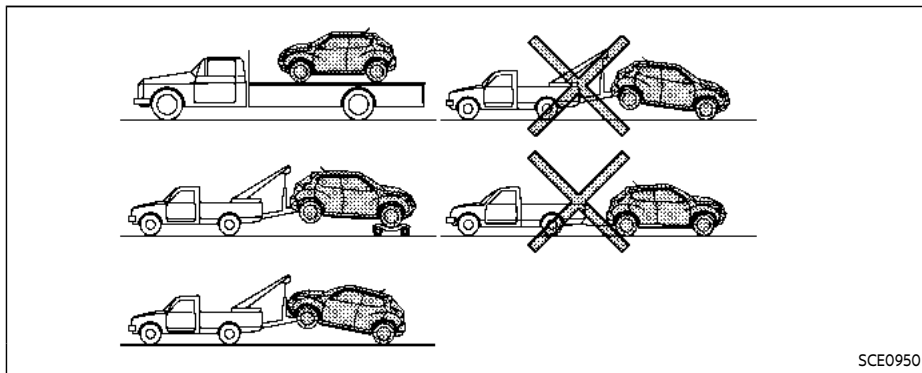

SCE0950

Two-Wheel Drive (2WD) models

NISSAN recommends that your vehicle be towed with the driving (front) wheels off the ground or place the vehicle on a flat bed truck as illustrated.

NOTE:

If the electronic parking brake is released, the rear wheels can be grounded while towing. If the electronic parking brake is not released, towing dollies should be used. For additional information, refer to "Parking brake" (P.5-25).



CAUTION

Never tow CVT models with the front wheels on the ground or four wheels on the ground (forward or backward), as this may cause serious and expensive damage to the transmission. If it is necessary to tow the vehicle with the rear wheels raised, always use towing dollies under the front wheels.

VEHICLE RECOVERY (freeing a stuck vehicle)



WARNING

To avoid vehicle damage, serious personal injury or death when recovering a stuck vehicle:

- Contact a professional towing service to recover the vehicle if you have any questions regarding the recovery procedure.
- Tow chains or cables must be attached only to main structural members of the vehicle.
- Do not use the vehicle tie-downs to tow or free a stuck vehicle.
- Only use devices specifically designed for vehicle recovery and follow the manufacturer's instructions.
- Always pull the recovery device straight out from the front of the vehicle. Never pull at an angle.
- Route recovery devices so they do not touch any part of the vehicle except the attachment point.

If your vehicle is stuck in sand, snow, mud,

In case of emergency 6-17

etc., use a tow strap or other device designed specifically for vehicle recovery. Always follow the manufacturer's instructions for the recovery device.

Rocking a stuck vehicle



WARNING

- **Stand clear of a stuck vehicle.**
- **Do not spin your tires at high speed. This could cause them to explode and result in serious injury. Parts of your vehicle could also overheat and be damaged.**

If your vehicle is stuck in sand, snow, mud, etc., use the following procedure:

1. Turn off the Vehicle Dynamic Control (VDC) system.
2. Make sure the area in front and behind the vehicle is clear of obstructions.
3. Turn the steering wheel right and left to clear an area around the front tires.
4. Slowly rock the vehicle forward and backward.
 - Shift back and forth between R (Reverse) and D (Drive).

- Apply the accelerator as little as possible to maintain the rocking motion.
 - Release the accelerator pedal before shifting between R and D.
 - Do not spin the tires above 35 MPH (55 km/h).
5. If the vehicle cannot be freed after a few tries, contact a professional towing service to remove the vehicle.

7 Appearance and care

Cleaning exterior	7-2	Cleaning interior	7-4
Washing	7-2	Air fresheners	7-5
Waxing	7-3	Floor mats	7-5
Removing spots	7-3	Seat belts	7-7
Underbody	7-3	Cleaning the seat tracks	7-7
Glass	7-3	Corrosion protection	7-7
Wheels	7-3	Most common factors contributing to vehicle corrosion	7-7
Aluminum alloy wheels	7-3	Environmental factors influence the rate of corrosion	7-7
Chrome parts	7-4	To protect your vehicle from corrosion	7-8
Tire dressing	7-4		

CLEANING EXTERIOR

In order to maintain the appearance of your vehicle, it is important to take proper care of it.

To protect the paint surfaces, wash your vehicle as soon as you can:

- after a rainfall to prevent possible damage from acid rain
- after driving on coastal roads
- when contaminants such as soot, bird droppings, tree sap, metal particles or bugs get on the paint surface
- when dust or mud builds up on the surface

Whenever possible, store or park your vehicle inside a garage or in a covered area.

When it is necessary to park outside, park in a shady area or protect the vehicle with a body cover.

Be careful not to scratch the paint surface when putting on or removing the body cover.

WASHING

Wash dirt off the vehicle with a wet sponge and plenty of water. Clean the vehicle thoroughly using a mild soap, a special vehicle soap or general purpose dishwashing liquid mixed with clean, lukewarm (never hot) water.



CAUTION

- **Do not concentrate water spray directly on the sonar sensors on the bumper as this will result in damage to the sensors. Do not use pressure washers capable of spraying water over 1,200 psi (8,274 kPa) to wash your vehicle. Use of high-pressure washers over, 1,200 psi (8,274 kPa) can result in damage to or removal of paint or graphics. Avoid using a high-pressure washer closer than 12 inches (30 cm) to the vehicle. Always use a wide-angle nozzle only, keep the nozzle moving and do not concentrate the water spray on any one area.**
- **Do not use car washes that use acid in the detergent. Some car washes, especially brushless ones, use some acid for cleaning. The acid may react with some plastic vehicle components, causing them to crack. This could affect their appearance, and also could cause them not to function properly. Always check with your car wash to confirm that acid is not used.**

- **Do not wash the vehicle with strong household soap, strong chemical detergents, gasoline or solvents.**
- **Do not wash the vehicle in direct sunlight or while the vehicle body is hot, as the surface may become water-spotted.**
- **Avoid using tight-napped or rough cloths, such as washing mitts. Care must be taken when removing caked-on dirt or other foreign substances so the paint surface is not scratched or damaged.**

Rinse the vehicle thoroughly with plenty of clean water.

Inside flanges, seams and folds on the doors, hatches and hood are particularly vulnerable to the effects of road salt. Therefore, these areas must be regularly cleaned. Make sure that the drain holes in the lower edge of the door are open. Spray water under the body and in the wheel wells to loosen the dirt and wash away road salt.

Avoid leaving water spots on the paint surface by using a damp chamois to dry the vehicle.

WAXING

Regular waxing protects the paint surface and helps retain new vehicle appearance. Polishing is recommended to remove built-up wax residue and to avoid a weathered appearance before reapplying wax.

A NISSAN dealer can assist you in choosing the proper product.

- Wax your vehicle only after a thorough washing. Follow the instructions supplied with the wax.
- Do not use a wax containing any abrasives, cutting compounds or cleaners that may damage the vehicle finish.

Machine compound or aggressive polishing on a base coat/clear coat paint finish may dull the finish or leave swirl marks.

REMOVING SPOTS

Remove tar and oil spots, industrial dust, insects, and tree sap as quickly as possible from the paint surface to avoid lasting damage or staining. Special cleaning products are available at a NISSAN dealer or any automotive accessory stores. It is recommended that you visit a NISSAN dealer for these products.

UNDERBODY

In areas where road salt is used in winter, the underbody must be cleaned regularly. This will prevent dirt and salt from building up and causing the acceleration of corrosion on the underbody and suspension. Before the winter period and again in the spring, the underseal must be checked and, if necessary, re-treated.

GLASS

Use glass cleaner to remove smoke and dust film from the glass surfaces. It is normal for glass to become coated with a film after the vehicle is parked in the hot sun. Glass cleaner and a soft cloth will easily remove this film.



CAUTION

When cleaning the inside of the windows, do not use sharp-edged tools, abrasive cleaners or chlorine-based disinfectant cleaners. They could damage the electrical conductors or rear window defroster elements.

WHEELS

Wash the wheels when washing the vehicle to maintain their appearance.

- Clean the inner side of the wheels when the wheel is changed or the underside of the vehicle is washed.
- Inspect wheel rims regularly for dents or corrosion. Such damage may cause loss of pressure or poor seal at the tire bead.
- NISSAN recommends that the road wheels be waxed to protect against road salt in areas where it is used during winter.



CAUTION

Do not use abrasive cleaners when washing the wheels.

ALUMINUM ALLOY WHEELS

Wash regularly with a sponge dampened in a mild soap solution, especially during winter months in areas where road salt is used. Salt could discolor the wheels if not removed.



CAUTION

Follow the directions below to avoid staining or discoloring the wheels:

- Do not use a cleaner that uses strong acid or alkali contents to clean the wheels.
- Do not apply wheel cleaners to the wheels when they are hot. The wheel temperature should be the same as ambient temperature.
- Rinse the wheel to completely remove the cleaner within 15 minutes after the cleaner is applied.

CHROME PARTS

Clean chrome parts regularly with a non-abrasive chrome polish to maintain the finish.

TIRE DRESSING

NISSAN does not recommend the use of tire dressings. Tire manufacturers apply a coating to the tires to help reduce discoloration of the rubber. If a tire dressing is applied to the tires, it may react with the coating and form a compound. This compound may come off the tire while

driving and stain the vehicle paint.

If you choose to use a tire dressing, take the following precautions:

- Use a water-based tire dressing. The coating on the tire dissolves more easily with an oil-based tire dressing.
- Apply a light coat of tire dressing to help prevent it from entering the tire tread/grooves (where it would be difficult to remove).
- Wipe off excess tire dressing using a dry towel. Make sure the tire dressing is completely removed from the tire tread/grooves.
- Allow the tire dressing to dry as recommended by tire dressing manufacturer.

CLEANING INTERIOR

Occasionally remove loose dust from the interior trim, plastic parts and seats using a vacuum cleaner or soft bristled brush. Wipe the vinyl and leather surfaces with a clean, soft cloth dampened in mild soap solution, then wipe clean with a dry soft cloth.

Regular care and cleaning is required in order to maintain the appearance of the leather (if so equipped).

Before using any fabric protector, read the manufacturer's recommendations. Some fabric protectors contain chemicals that may stain or bleach the seat material.

Use a cloth dampened only with water, to clean the meter and gauge lens.



WARNING

Do not use water or acidic cleaners (hot steam cleaners) on the seat. This can damage the seat or occupant classification sensors. This can also affect the operation of the air bag system and result in serious personal injury.



CAUTION

- Never use benzine, thinner, or any similar material.
- For cleaning, use a soft cloth, dampened with water. Never use a rough cloth, alcohol, benzine, thinner or any kind of solvent or paper towel with a chemical cleaning agent. They will scratch or cause discoloration to the lens.
- Do not spray any liquid such as water on the meter lens. Spraying liquid may cause the system to malfunction.
- Small dirt particles can be abrasive and damaging to the leather surfaces and should be removed promptly. Do not use saddle soap, car waxes, polishes, oils, cleaning fluids, solvents, detergents or ammonia-based cleaners as they may damage the leather's natural finish.
- Never use fabric protectors unless recommended by the manufacturer.
- Do not use glass or plastic cleaner on meter or gauge lens covers. It may damage the lens cover.

- Do not spill on or make contact with interior surfaces while handling air fresheners, aroma agents, cosmetics, sunscreen, etc. They may cause permanent discoloration, stain, crack, paint peeling, etc. depending on the ingredients. If they contact the interior surface, wipe them off immediately using a soft cloth.
- Do not use the chlorine-based cleaning liquid such as chlorine dioxide and hypochlorous acid, which may cause the paint peeling, corrosion, etc. If it is unavoidable to clean or sterilize interior surfaces, use less than 75% ethanol. Wipe the interior parts with a dry cloth dampened with ethanol. Wipe off ethanol completely. If you leave it uncleaned, it may cause paint peeling, discoloration, etc. Since ethanol is flammable, be careful of fire.

AIR FRESHENERS

Most air fresheners use a solvent that could affect the vehicle interior. If you use an air freshener, take the following precautions:

- Hanging-type air fresheners can cause permanent discoloration when they contact vehicle interior surfaces. Place the air freshener in a location that allows it to hang free and not contact an interior surface.
- Liquid-type air fresheners typically clip on the vents. These products can cause immediate damage and discoloration when spilled on interior surfaces.

Carefully read and follow the manufacturer's instructions before using air fresheners.

FLOOR MATS



WARNING

To avoid potential pedal interference that may result in a collision, injury or death:

- NEVER place a floor mat on top of another floor mat in the driver front position or install them upside down or backwards.

- It is recommended that you use only genuine NISSAN floor mats specifically designed for use in your vehicle model and model year.
- Properly position the mats in the floorwell using the floor mat positioning hooks. See "Floor mat installation" (P.7-6).
- Make sure the floor mat does not interfere with pedal operation.
- Periodically check the floor mats to make sure they are properly installed.
- After cleaning the vehicle interior, check the floor mats to make sure they are properly installed.

The use of genuine NISSAN floor mats can extend the life of your vehicle carpet and make it easier to clean the interior. Mats should be maintained with regular cleaning and replaced if they become excessively worn.

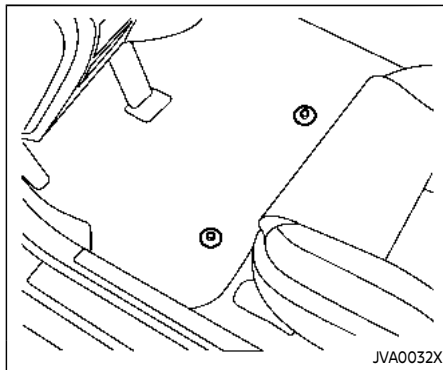

Floor mat installation

Your vehicle is equipped with floor mat positioning hook(s). The number and shape of the floor mat positioning hook (s) for each seating position varies depending on the vehicle.

When installing genuine NISSAN floor mats, follow the installation instructions provided with the floor mat and the following:

1. Position the floor mat in the floorwell so that the floor mat grommet holes are aligned with the hook(s).
2. Push the grommet holes into the hook (s) and secure them. Ensure that the

floor mat is properly positioned.

3. Make sure the floor mat does not interfere with pedal operation. With the ignition in the OFF position and the shift position in the P (Park) position, fully apply and release all pedals. The floor mat must not interfere with pedal operation or prevent the pedal from returning to its normal position. It is recommended you see a NISSAN dealer for details about installing the floor mats in your vehicle.

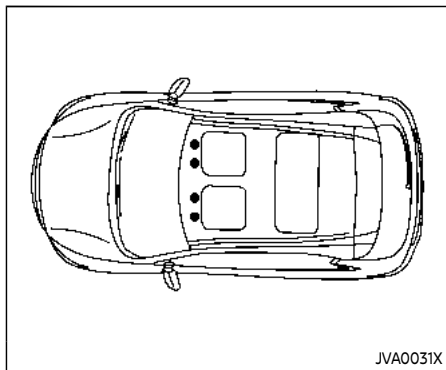

Positioning hook(s)

The illustration shows the location of the floor mat positioning hook(s).

SEAT BELTS

The seat belts can be cleaned by wiping them with a sponge dampened in a mild soap solution. Allow the belts to dry completely in the shade before using them.

See "Seat belts" (P.1-15).



WARNING

Do not allow wet seat belts to roll up in the retractor. NEVER use bleach,

dye, or chemical solvents to clean the seat belts, since these materials may severely weaken the seat belt webbing.

CLEANING THE SEAT TRACKS



CAUTION

Periodically clean the seat tracks to prevent reduction of ability to move the seats.

Clean periodically with a high-powered vacuum cleaner. Dirt and debris may reduce the ability to adjust the seat. A wet cleansing agent may be used if necessary.

CORROSION PROTECTION

MOST COMMON FACTORS CONTRIBUTING TO VEHICLE CORROSION

- The accumulation of moisture-retaining dirt and debris in body panel sections, cavities, and other areas.
- Damage to paint and other protective coatings caused by gravel and stone chips or minor traffic accidents.

ENVIRONMENTAL FACTORS INFLUENCE THE RATE OF CORROSION

Moisture

Accumulation of sand, dirt and water on the vehicle body underside can accelerate corrosion. Wet floor coverings will not dry completely inside the vehicle, and should be removed for drying to avoid floor panel corrosion.

Relative humidity

Corrosion will be accelerated in areas of high relative humidity, especially those areas where the temperatures stay above freezing where atmospheric pollution exists, or where road salt is used.

Temperature

A temperature increase will accelerate the rate of corrosion to those parts which are not well ventilated.

Air pollution

Industrial pollution, the presence of salt in the air in coastal areas, or heavy road salt use will accelerate the corrosion process. Road salt will also accelerate the disintegration of paint surfaces.

TO PROTECT YOUR VEHICLE FROM CORROSION

- Wash and wax your vehicle often to keep the vehicle clean.
- Always check for minor damage to the paint and repair it as soon as possible.
- Keep drain holes at the bottom of the doors open to avoid water accumulation.
- Check the underbody for accumulation of sand, dirt or salt. If present, wash with water as soon as possible.



CAUTION

- **NEVER remove dirt, sand or other debris from the passenger compartment by washing it out with a hose. Remove dirt with a vacuum**

cleaner.

- **Never allow water or other liquids to come in contact with electronic components inside the vehicle as this may damage them.**

Chemicals used for road surface deicing are extremely corrosive. They accelerate corrosion and deterioration of underbody components such as the exhaust system, fuel and brake lines, brake cables, floor pan and fenders.

In winter, the underbody must be cleaned periodically.

For additional protection against rust and corrosion, which may be required in some areas, it is recommended you consult a NISSAN dealer.

8 Do-it-yourself

Maintenance precautions	8-2	Air cleaner	8-18
Engine compartment check locations	8-3	Windshield wiper blades	8-19
PR25DD engine model	8-3	Cleaning	8-19
KR15DDT engine model	8-4	Replacing	8-20
Engine cooling system	8-4	Rear window wiper blade	8-20
Checking engine coolant level	8-6	Brakes	8-21
Changing engine coolant	8-6	Self-adjusting brakes	8-21
Intercooler cooling system (if so equipped)	8-6	Brake pad wear warning	8-21
Checking intercooler coolant level	8-7	Fuses	8-21
Changing intercooler coolant	8-8	Engine compartment	8-21
Engine oil	8-8	Passenger compartment	8-23
Checking engine oil level	8-8	Intelligent Key battery replacement	8-24
Changing engine oil and filter	8-8	Lights	8-27
Continuously Variable Transmission (CVT) fluid	8-12	Headlights	8-28
Brake fluid	8-12	Exterior and interior lights	8-28
Window washer fluid	8-13	Wheels and tires	8-30
Battery	8-14	Tire pressure	8-30
Jump starting	8-15	Tire labeling	8-34
Variable voltage control system	8-16	Types of tires	8-36
Drive belt	8-16	Tire chains	8-37
Spark plugs	8-17	Changing wheels and tires	8-38
Replacing spark plugs	8-18		

MAINTENANCE PRECAUTIONS

When performing any inspection or maintenance work on your vehicle, always take care to prevent serious accidental injury to yourself or damage to the vehicle. The following are general precautions which should be closely observed.



WARNING

- Park the vehicle on a level surface, apply the parking brake securely and block the wheels to prevent the vehicle from moving. Push the park button to shift to the P (Park) position.
- Be sure the ignition switch is in the OFF position when performing any parts replacement or repairs.
- If you must work with the engine running, keep your hands, clothing, hair and tools away from moving fans, belts and any other moving parts.
- It is advisable to secure or remove any loose clothing and remove any jewelry, such as rings, watches, etc. before working on your vehicle.

- Always wear eye protection whenever you work on your vehicle.
- If you must run the engine in an enclosed space such as a garage, be sure there is proper ventilation for exhaust gases to escape.
- Never get under the vehicle while it is supported only by a jack. If it is necessary to work under the vehicle, support it with safety stands.
- Because the fuel lines are under high pressure even when the engine is off, it is recommended you visit a NISSAN dealer for service of the fuel filter or fuel lines.
- Keep smoking materials, flame and sparks away from fuel and the battery.
- On gasoline engine models with the Multiport Fuel Injection (MFI) system, the fuel filter and fuel lines should be serviced because the fuel lines are under high pressure even when the engine is turned off. It is recommended that you visit a NISSAN dealer for this service.

- Your vehicle is equipped with an automatic engine cooling fan. It may come on at any time without warning, even if the ignition switch is in the OFF position and the engine is not running. To avoid injury, always disconnect the negative battery cable before working near the fan.



CAUTION

- Do not work under the hood while the engine is hot. Turn the engine off and wait until it cools down.
- Avoid direct contact with used engine oil and coolant. Improperly disposed engine oil, and engine coolant and/or other vehicle fluids can damage the environment. Always conform to local regulations for disposal of vehicle fluid.
- Never leave the engine or the CVT related component harnesses disconnected while the ignition switch is in the ON position.
- Never connect or disconnect the battery or any transistorized component while the ignition

ENGINE COMPARTMENT CHECK LOCATIONS

switch is in the ON position.

This "8. Do-it-yourself" section gives instructions regarding only those items which are relatively easy for an owner to perform.

A genuine NISSAN Service Manual is also available. (See "Owner's manual/service manual order information" (P.10-33).)

You should be aware that incomplete or improper servicing may result in operating difficulties or excessive emissions, and could affect your warranty coverage. **If in doubt about any servicing, it is recommended you have it done by a NISSAN dealer.**

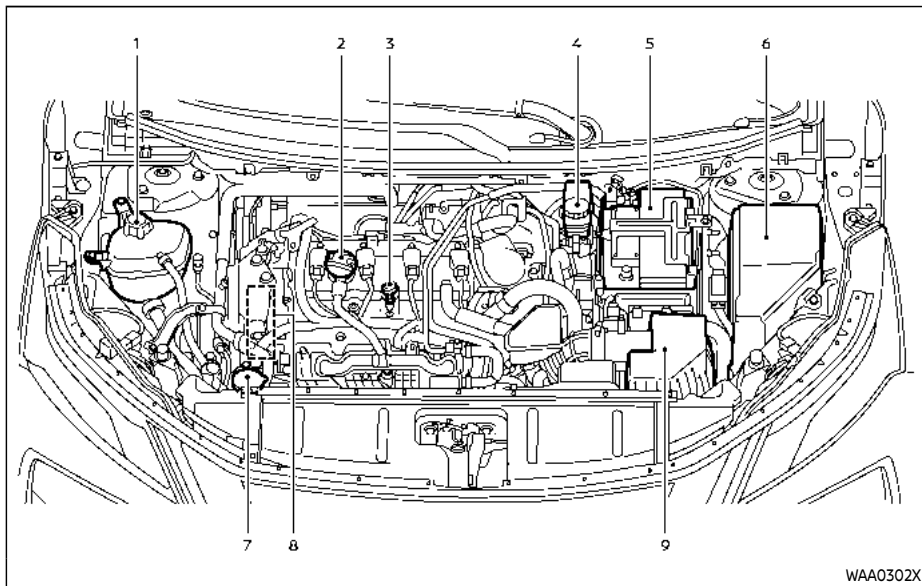

PR25DD ENGINE MODEL

- | | |
|-----------------------------|----------------------------------|
| 1. Engine coolant reservoir | 7. Window washer fluid reservoir |
| 2. Engine oil filler cap | 8. Drive belt |
| 3. Engine oil dipstick | 9. Air cleaner |
| 4. Brake fluid reservoir | |
| 5. Battery | |
| 6. Fuse/fuse link box | |

ENGINE COOLING SYSTEM

The engine cooling system is filled at the factory with a pre-diluted mixture of 50% Genuine NISSAN Long Life Antifreeze/Coolant (blue) and 50% water to provide year-round anti-freeze and coolant protection. The anti-freeze solution contains rust and corrosion inhibitors. Additional engine cooling system additives are not necessary.

WARNING

- **Never remove the radiator or coolant reservoir cap when the engine is hot. Wait until the engine and radiator cool down. Serious burns could be caused by high pressure fluid escaping from the radiator or coolant reservoir. See precautions in "If your vehicle overheats" (P.6-14) of this manual.**
- **The coolant reservoir is equipped with a pressure type coolant reservoir cap. To prevent engine damage, use only a genuine NISSAN coolant reservoir cap.**
- **If the engine was stopped soon when the engine is hot, the cooling fan may operate for approximately 10 minutes after the**

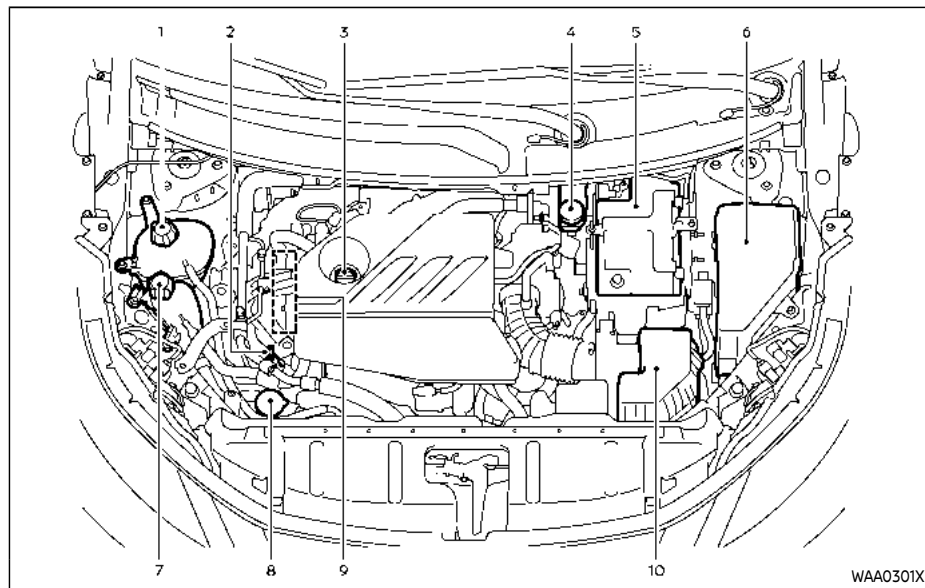

WAA0301X

KR15DDT ENGINE MODEL

- | | |
|-----------------------------|----------------------------------|
| 1. Engine coolant reservoir | 7. Intercooler coolant reservoir |
| 2. Engine oil dipstick | 8. Window washer fluid reservoir |
| 3. Engine oil filler cap | 9. Drive belt |
| 4. Brake fluid reservoir | 10. Air cleaner |
| 5. Battery | |
| 6. Fuse/fusible link box | |

engine was stopped to cool the components in the engine compartment. When the cooling fan is operating, be sure that hands or other items do not get caught in it.

CAUTION

- Never use any cooling system additives such as radiator sealer. Additives may clog the cooling system and cause damage to the engine, transmission and/or cooling system.
- When adding or replacing coolant, be sure to use only Genuine NISSAN Long Life Antifreeze/Coolant (blue) or equivalent. Genuine NISSAN Long Life Antifreeze/Coolant (blue) is pre-diluted to provide antifreeze protection to -34°F (-37°C). If additional freeze protection is needed due to weather where you operate your vehicle, add Genuine NISSAN Long Life Antifreeze/Coolant (blue) concentrate following the directions on the container. If an equivalent coolant other than

Genuine NISSAN Long Life Antifreeze/Coolant (blue) is used, follow the coolant manufacturer's instructions to maintain minimum antifreeze protection to -34°F (-37°C). The use of other types of coolant solutions other than Genuine NISSAN Long Life Antifreeze/Coolant (blue) or equivalent may damage the engine cooling system.

- The life expectancy of the factory-fill coolant is 105,000 miles (168,000 km) or 7 years. Mixing any other type of coolant other than Genuine NISSAN Long Life Antifreeze/Coolant (blue), including Genuine NISSAN Long Life Antifreeze/Coolant (green), or the use of non-distilled water will reduce the life expectancy of the factory-fill coolant. Refer to the "9. Maintenance and schedules" section of this manual for more details.

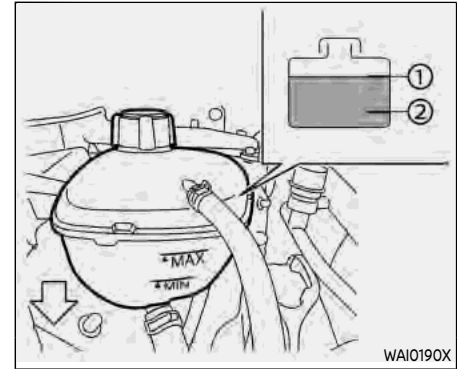

PR25DD engine

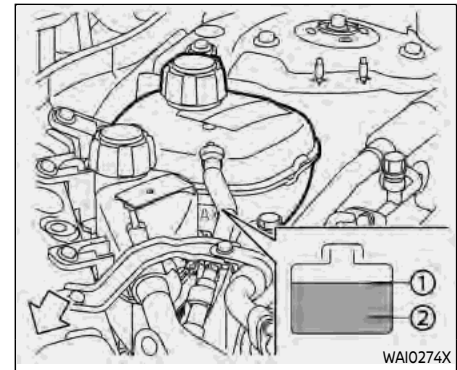

KR15DDT engine

CHECKING ENGINE COOLANT LEVEL

Check the coolant level **in the reservoir when the engine is cold**. If the coolant level is below the MIN level ②, open the reservoir cap and add coolant up to the MAX level ①.

Tighten the cap securely after adding engine coolant.

If the cooling system frequently requires coolant, have it checked. It is recommended you visit a NISSAN dealer for this service.

CHANGING ENGINE COOLANT

A NISSAN dealer can change the engine coolant. The service procedure can be found in the NISSAN Service Manual.

Improper servicing can result in reduced heater performance and engine overheating.



WARNING

- **To avoid being scalded, never change the coolant when the engine is hot.**
- **Never remove the radiator or coolant reservoir cap when the engine is hot. Serious burns could be caused by high pressure fluid escaping from the radiator or**

coolant reservoir.

- **Avoid direct skin contact with used coolant. If skin contact is made, wash thoroughly with soap or hand cleaner as soon as possible.**
- **Keep coolant out of the reach of children and pets.**

Engine coolant must be disposed of properly. Check your local regulations.

INTERCOOLER COOLING SYSTEM (if so equipped)

The intercooler cooling system is filled at the factory with a pre-diluted mixture of 50% Genuine NISSAN Long Life Antifreeze/Coolant (blue) and 50% water to provide year-round anti-freeze and coolant protection. The antifreeze solution contains rust and corrosion inhibitors. Additional intercooler cooling system additives are not necessary.



WARNING

- **Never remove the radiator or coolant reservoir cap when the engine is hot. Wait until the engine cools down. Serious burns could be caused by high pressure fluid escaping from the radiator or coolant reservoir.**
- **The coolant reservoir is equipped with a pressure type coolant reservoir cap. To prevent engine and intercooler damage, use only a genuine NISSAN coolant reservoir cap.**

CAUTION

- Never use any additives in the coolant such as radiator sealer in the cooling system. This may cause damage to the intercooler.
- When adding or replacing coolant, be sure to use only Genuine NISSAN Long Life Antifreeze/Coolant (blue) or equivalent. Genuine NISSAN Long Life Antifreeze/Coolant (blue) is pre-diluted to provide antifreeze protection to -34°F (-37°C). If additional freeze protection is needed due to weather where you operate your vehicle, add Genuine NISSAN Long Life Antifreeze/Coolant (blue) concentrate following the directions on the container. If an equivalent coolant other than Genuine NISSAN Long Life Antifreeze/Coolant (blue) is used, follow the coolant manufacturer's instructions to maintain minimum antifreeze protection to -34°F (-37°C). The use of other types of coolant solutions other than Genuine NISSAN Long Life Antifreeze/Coolant (blue) or equivalent may damage the in-

tercooler cooling system.

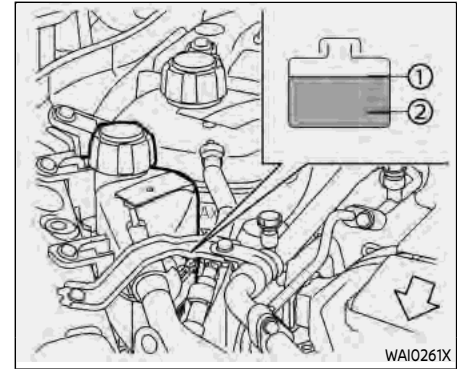

CHECKING INTERCOOLER COOLANT LEVEL

Check the coolant level in the reservoir when the engine is cold. If the coolant level is below the MIN level ②, add coolant to the MAX level ①.

Tighten the cap securely after adding intercooler coolant.

If the intercooler cooling system frequently requires coolant, have it checked. It is recommended you visit a NISSAN dealer for this service.

CHANGING INTERCOOLER COOLANT

Intercooler coolant is maintenance-free.

If replacement is required, it is recommended you visit a NISSAN dealer for this service.

Improper servicing can result in intercooler overheating.

WARNING

- To avoid the danger of being scalded, never change the coolant when the engine is hot.
- Never remove the radiator or coolant reservoir cap when the engine is hot. Serious burns could be caused by high pressure fluid escaping from the radiator or coolant reservoir.
- Avoid direct skin contact with used coolant. If skin contact is made, wash thoroughly with soap or hand cleaner as soon as possible.
- Keep coolant out of the reach of children and pets.

Intercooler coolant must be disposed of properly. Check your local regulations.

8-8 Do-it-yourself

ENGINE OIL

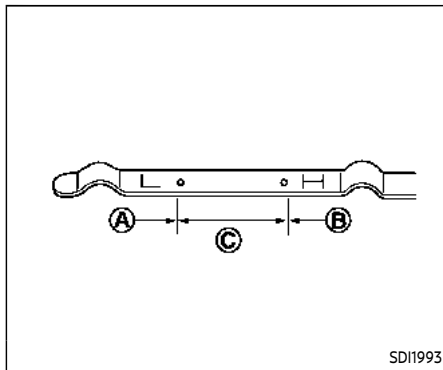

CHECKING ENGINE OIL LEVEL

1. Park the vehicle on a level surface and apply the parking brake.
2. Run the engine until it reaches operating temperature.
3. Turn off the engine. **Wait more than 10 minutes for the oil to drain back into the oil pan.**
4. Remove the dipstick and wipe it clean. Reinsert it all the way.
5. Remove the dipstick again and check the oil level. It should be within the range C. If the oil level is below A, remove the oil filler cap and pour recommended oil through the open-

ing. **Do not overfill B.**

6. Recheck oil level with the dipstick.

It is normal to add some oil between oil maintenance intervals or during the break-in period, depending on the severity of operating conditions.

CAUTION

Oil level should be checked regularly. Operating the engine with an insufficient amount of oil can damage the engine, and such damage is not covered by the warranty.

CHANGING ENGINE OIL AND FILTER

WARNING

- Used oil must be disposed of properly. Never pour or dump oil into the ground, canals, rivers, etc. It should be disposed of at proper waste facilities. NISSAN recommends having your oil changed by a NISSAN dealer.
- Be careful not to burn yourself, as the engine oil may be hot.

- **Prolonged and repeated contact with used engine oil may cause skin cancer.**
- **Avoid direct skin contact with used oil. If contacted, wash thoroughly with soap or hand cleaner and plenty of water as soon as possible.**
- **Store used engine oil in marked containers out of the reach of children.**

- Then remove the other bolts that hold the undercover in place.



CAUTION

Make sure the correct lifting and support points are used to avoid vehicle damage.

Engine oil and filter

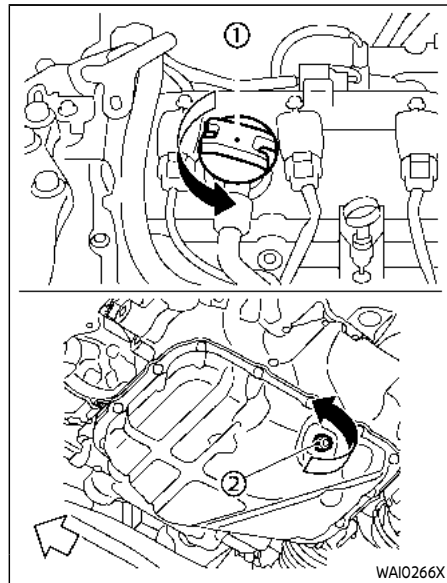

PR25DD engine

Vehicle set-up

1. Park the vehicle on a level surface and apply the parking brake.
2. Run the engine until it reaches the operating temperature.
3. Turn the engine off and wait more than 10 minutes.
4. Raise and support the vehicle using a suitable floor jack and safety jack stands.
 - Place the safety jack stands under the vehicle jack-up points.
 - A suitable adapter should be attached to the jack stand saddle.
5. Remove the engine undercover.
 - Remove clips at the around of the undercover.

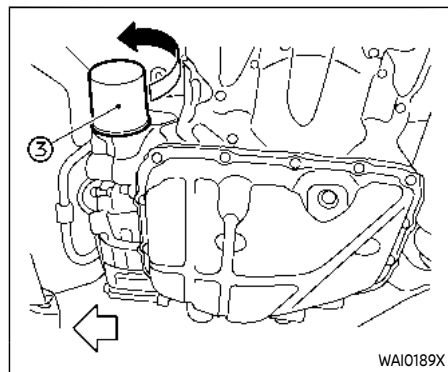

PR25DD engine

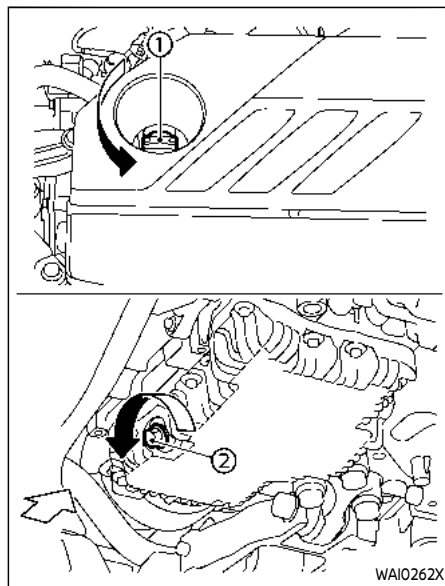

KR15DDT engine

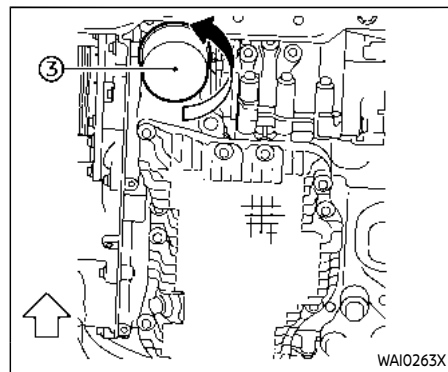

KR15DDT engine

- ① Oil filler cap
- ② Oil drain plug
- ③ Oil filter

1. Place a large drain pan under the drain plug.
2. Remove the oil filler cap.
3. Remove the drain plug with a wrench and completely drain the oil.



CAUTION

Be careful not to burn yourself, as the engine oil is hot.



WARNING

- **Prolonged and repeated contact with used engine oil may cause skin cancer.**
- **Try to avoid direct skin contact with used oil. If skin contact is made, wash thoroughly with soap or hand cleaner as soon as possible.**
- **Keep used engine oil out of reach of children.**

- **Waste oil must be disposed of properly.**
- **Check your local regulations.**

(Perform steps 4 to 7 only when the engine oil filter change is needed.)

4. Loosen the oil filter with an oil filter wrench. Remove the oil filter by turning it by hand.
5. Wipe the engine oil filter mounting surface with a clean rag.



CAUTION

Be sure to remove any old gasket material remaining on the mounting surface of the engine. Failure to do

so could lead to engine damage.

6. Coat the gasket on the new filter with clean engine oil.
7. Screw in the oil filter clockwise until a slight resistance is felt, then tighten additionally more than 2/3 turn.

Oil filter tightening torque:

- **PR25DD engine**
11 to 15 ft-lb
(14.7 to 20.6 N·m)
- **KR15DDT engine**
11 to 15 ft-lb
(15.0 to 21.0 N·m)

8. Clean and re-install the drain plug with a new washer. Securely tighten the drain plug with a wrench.

Drain plug tightening torque:

- **PR25DD engine**
22 to 29 ft-lb
(29.4 to 39.2 N·m)
- **KR15DDT engine**
22 to 27 ft-lb
(30.0 to 37.0 N·m)

Do not use excessive force.

9. Refill the engine with the recommended oil through the oil filler opening, and install the oil filler cap securely.

See "Capacities and recommended

fluids/lubricants" (P.10-3) for drain and refill capacity. The drain and refill capacity depends on the oil temperature and drain time. Use these specifications for reference only. Always use the dipstick to determine the proper amount of oil in the engine.

10. Start the engine and check for leakage around the drain plug and the oil filter. Correct as required.
11. Turn the engine off and wait more than 10 minutes. Check the oil level with the dipstick. Add engine oil if necessary.

After the operation

1. Reinstall undercover in reverse order of removal.
2. Lower the vehicle carefully to the ground.
3. Reset the Oil Control System and oil and filter maintenance reminder. (See "Maintenance" (P.2-29).)

CONTINUOUSLY VARIABLE TRANSMISSION (CVT) FLUID

When checking or replacement is required, we recommend a NISSAN dealer for servicing.

CAUTION

- NISSAN recommends using Genuine NISSAN CVT Fluid NS-3 (or equivalent) ONLY in NISSAN CVTs. Do not mix with other fluids.
- Do not use Automatic transmission fluid (ATF) or Manual Transmission fluid in a NISSAN CVT, as it may damage the CVT. Damage caused by the use of fluids other than as recommended is not covered by the NISSAN's New Vehicle Limited Warranty.
- Using fluids that are not equivalent to Genuine NISSAN CVT Fluid NS-3 may also damage the CVT. Damage caused by the use of fluids other than as recommended is not covered under the NISSAN's New Vehicle Limited Warranty.

BRAKE FLUID

For additional brake fluid information, see "Capacities and recommended fluids/lubricants" (P.10-3) of this manual.

WARNING

- Use only new fluid from a sealed container. Old, inferior or contaminated fluid may damage the brake system. The use of improper fluids can damage the brake system, and affect the vehicle's stopping ability.
- Clean the filler cap before removing.
- Brake fluid is poisonous and should be stored carefully in marked containers out of the reach of children.

CAUTION

Do not spill the fluid on any painted surfaces. This will damage the paint. If fluid is spilled, immediately wash the surface with water.

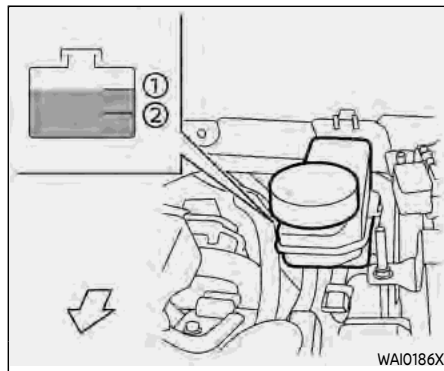

Check the fluid level in the reservoir. If the fluid is below the MIN line ② or the brake warning light comes on, add Genuine NISSAN Super Heavy Duty Brake Fluid or equivalent DOT 3 fluid up to the MAX line ① and it is recommended you have your vehicle checked by a NISSAN dealer as soon as possible. If fluid must be added frequently, the system should be checked. It is recommended you visit a NISSAN dealer for this service.

WINDOW WASHER FLUID

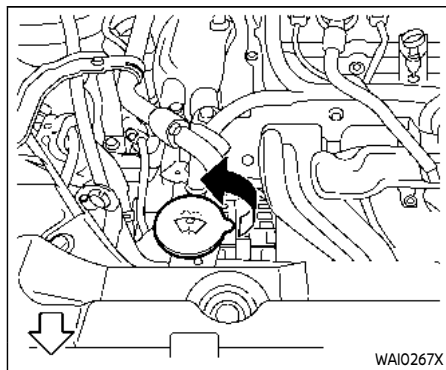

Type A (if so equipped)

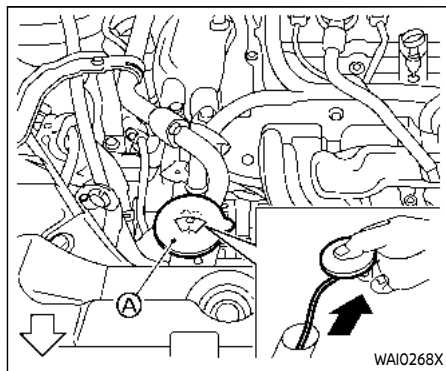

Type B (if so equipped)

Type A: Check the fluid level in the window washer reservoir. If the fluid level is low, add window washer fluid.

Type B: To check the fluid level, use your finger to plug the center hole (A) of the cap/tube assembly, then remove it from the reservoir. If there is no fluid in the tube, add fluid.

Add a washer solvent to the washer for better cleaning. In the winter season, add a windshield washer antifreeze. Follow the manufacturer's instructions for the mixture ratio.

Fill the window washer fluid reservoir periodically.

Add fluid when the low washer fluid warning appears (if so equipped).

Refill the reservoir more frequently when driving conditions require an increased amount of window washer fluid.

Recommended fluid:

Genuine NISSAN Windshield Washer Concentrate Cleaner & Antifreeze or equivalent









CAUTION

- Do not substitute engine anti-freeze coolant for window washer solution. This may result

in damage to the paint.

- Do not fill the window washer reservoir tank with washer fluid concentrates at full strength. Some methyl alcohol based washer fluid concentrates may permanently stain the grille if spilled while filling the window washer reservoir tank.
- Pre-mix washer fluid concentrates with water to the manufacturer's recommended levels before pouring the fluid into the window washer reservoir tank. Do not use the window washer reservoir tank to mix the washer fluid concentrate and water.

BATTERY

Caution symbols for battery		⚠ WARNING
①	 <p>No smoking, No exposed flames, No sparks</p>	Do not expose the battery to electrical sparks, flames or smoking. Hydrogen gas generated by the battery is explosive. Explosive gases can cause blindness or injury.
②	 <p>Shield eyes</p>	Handle the battery cautiously. Always wear eye protection glasses to protect against explosion or battery acid.
③	 <p>Keep away from children</p>	Never allow children to handle battery. Keep the battery out of the reach of children.
④	 <p>Battery acid</p>	Do not allow battery fluid to contact your skin, eyes, fabrics, or painted surfaces. Sulfuric acid can cause blindness or severe burns. After touching a battery or battery cap, do not touch or rub your eyes. Thoroughly wash your hands. If the acid contacts your eyes, skin or clothing, immediately flush with water for at least 15 minutes and seek medical attention. Battery fluid is acidic. If the battery fluid gets into your eyes or onto your skin, it could cause loss of your eyesight or burns.
⑤	 <p>Note operating instructions</p>	Before handling the battery, read this instruction carefully to ensure correct and safe handling.
⑥	 <p>Explosive gas</p>	Hydrogen gas generated by battery fluid is explosive. Explosive gases can cause blindness or injury.

WAI0270X

- If the battery is labeled “do not open” it is maintenance free and battery fluid should not be checked. It is recommended that you visit a NISSAN dealer or a qualified specialist workshop to confirm the battery's performance.
- Keep the battery surface clean and dry. Clean the battery with a solution of baking soda and water.
- Make certain the terminal connections are clean and securely tightened.
- If the vehicle is not to be used for 30 days or longer, disconnect the negative \ominus battery terminal cable to prevent discharging it.

NOTE:

Care should be taken to avoid situations that can lead to potential battery discharge and potential no-start conditions such as:

1. Installation or extended use of electronic accessories that consume battery power when the engine is not running (Phone chargers, GPS, DVD players, etc.).
2. Vehicle is not driven regularly and/ or only driven short distances.

In these cases, the battery may need to be charged to maintain battery health.



WARNING

- Do not expose the battery to flames or electrical sparks. Hydrogen gas generated by the battery is explosive. Do not allow battery fluid to contact your skin, eyes, fabrics or painted surfaces. After touching a battery or battery cap, do not touch or rub your eyes. Thoroughly wash your eyes, skin or clothing, immediately flush with water for at least 15 minutes and seek medical attention.
- When working on or near a battery, always wear suitable eye protection and remove all jewelry.
- Battery posts, terminals and related accessories contain lead and lead compounds. Wash hands after handling.
- Keep the battery out of the reach of children.
- Do not tip the battery.

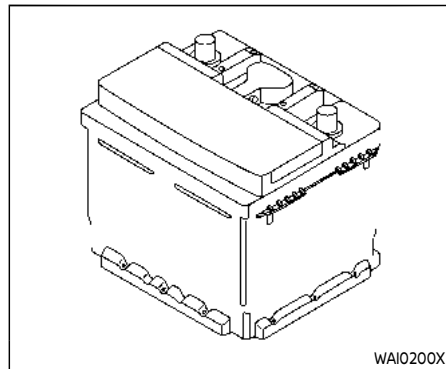

Example

NOTE:

Do not try to open the top of the battery.

This battery is not equipped with removable vent caps.

JUMP STARTING

If jump starting is necessary, see “Jump starting” (P.6-11). If the engine does not start by jump starting, the battery may have to be replaced. It is recommended you visit a NISSAN dealer for this service.

VARIABLE VOLTAGE CONTROL SYSTEM

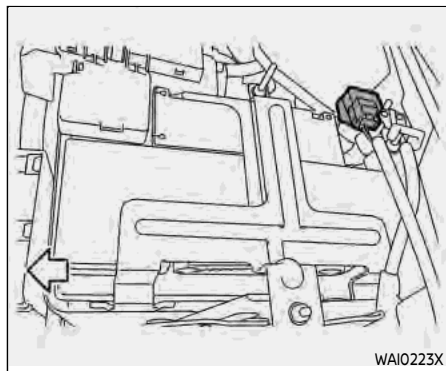

CAUTION

- Do not ground accessories directly to the battery terminal. Doing so will bypass the variable voltage control system and the vehicle battery may not charge completely.
- Use electrical accessories with the engine running to avoid discharging the vehicle battery.

The variable voltage control system measures the amount of electrical discharge from the battery and controls voltage

generated by the generator.

DRIVE BELT

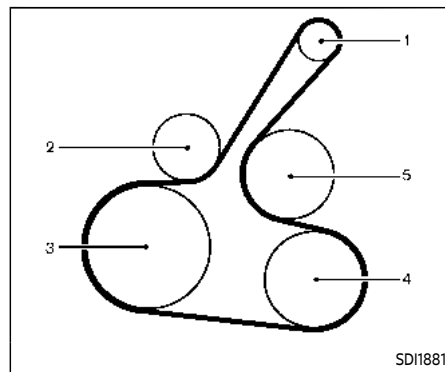

PR25DD engine

1. Alternator
2. Drive belt auto-tensioner
3. Crankshaft pulley
4. Air conditioner compressor
5. Water pump

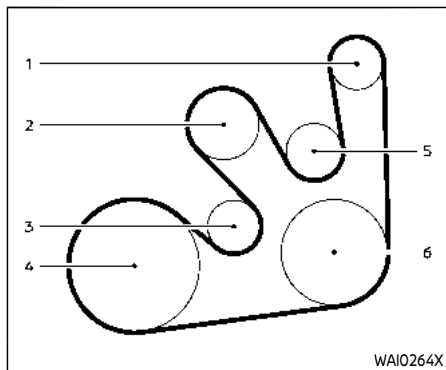

KR15DDT engine

1. Alternator
2. Water pump
3. Drive belt auto-tensioner
4. Crankshaft pulley
5. Idler pulley
6. Air conditioner compressor



WARNING

Be sure the ignition switch is in the OFF position before servicing drive belts. The engine could rotate unexpectedly.

1. Visually inspect the belt for signs of unusual wear, cuts or fraying. If the belt is in poor condition, have it replaced. It is recommended that you visit a NISSAN dealer for this service.
2. Have the belt condition checked regularly.

SPARK PLUGS



WARNING

Be sure the engine and ignition switch are off and that the parking brake is applied.



CAUTION

Be sure to use the correct socket to remove the spark plugs. An incorrect socket can damage the spark plugs.

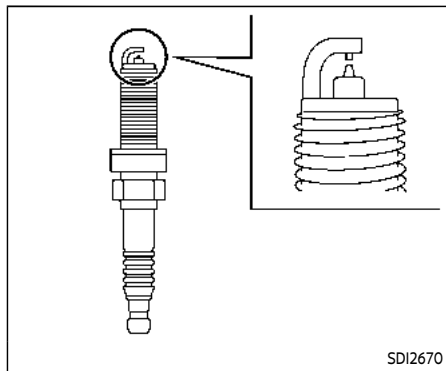

mended or equivalent ones.

REPLACING SPARK PLUGS

If replacement is required, it is recommended you visit a NISSAN dealer for this service.

Iridium platinum-tipped spark plugs

It is not necessary to replace the iridium platinum-tipped spark plugs as frequently as the conventional type spark plugs since they will last much longer. Follow the maintenance schedule shown in the "9. Maintenance and schedules" section. Do not reuse the iridium platinum-tipped spark plugs by cleaning or regapping.

Always replace spark plugs with recom-

AIR CLEANER

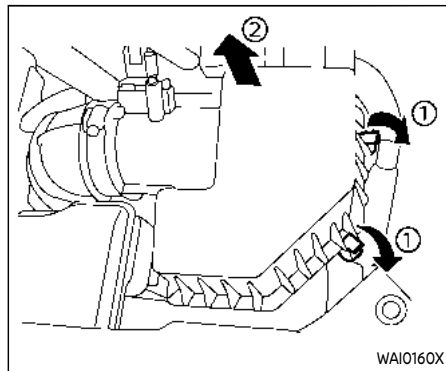

To remove the filter, release the lock pins ① and pull the unit upward ②.

The viscous paper type filter element (if so equipped) should not be cleaned and reused. The dry paper type filter element (if so equipped) may be cleaned and reused. Replace the filter according to the maintenance schedule shown in the "9. Maintenance and schedules" section. When replacing the filter, wipe the inside of the air cleaner housing and the cover with a damp cloth.



WARNING

- **Operating the engine with the air cleaner filter off can cause you or others to be burned. The air cleaner filter not only cleans the intake air, it also stops flame if the engine backfires. If the air cleaner filter is not installed and the engine backfires, you could be burned. Never drive with the air cleaner filter off. Be cautious working on the engine when the air cleaner filter is off.**
- **Never pour fuel into the throttle body or attempt to start the engine with the air cleaner removed. Doing so could result in serious injury.**

WINDSHIELD WIPER BLADES

CLEANING

If your windshield is not clear after using the windshield washer or if a wiper blade chatters when running, wax or other material may be on the blade or windshield.

Clean the outside of the windshield with a washer solution or a mild detergent. Your windshield is clean if beads do not form when rinsing with clear water.

Clean each blade by wiping it with a cloth soaked in a washer solution or a mild detergent. Then rinse the blade with clear water. If your windshield is still not clear after cleaning the blades and using the wiper, replace the blades.



CAUTION

Worn windshield wiper blades can damage the windshield and impair driver vision.

When a washer nozzle is clogged

It is recommended you see a NISSAN dealer if a washer nozzle is clogged or any malfunction occurs. Do not attempt to clean the nozzle using a needle or a pin. Doing so may damage the nozzle.

REAR WINDOW WIPER BLADE

It is recommended you contact a NISSAN dealer if checking or replacement is required.

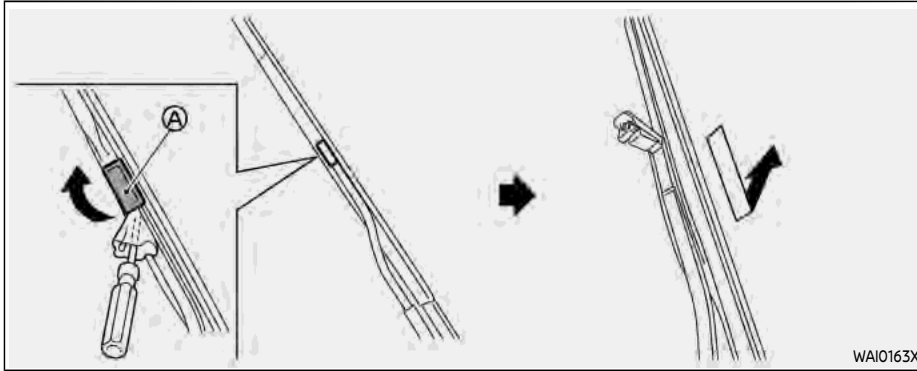

REPLACING

Replace the wiper blades if they are worn.

1. Lift the wiper arm away from the windshield.
2. Open **A**, using a suitable tool, and then move the wiper blade down as shown to remove.
3. Insert the new wiper blade onto the wiper arm until a click sounds.
4. Close **A**.

CAUTION

- **After wiper blade replacement, return the wiper arm to its original position; otherwise it may be damaged when the hood is opened.**
- **Make sure the wiper blades contact the glass; otherwise the arm may be damaged from wind pressure.**

BRAKES

If the brakes do not operate properly, it is recommended you have the brakes checked by a NISSAN dealer.

SELF-ADJUSTING BRAKES

Your vehicle is equipped with self-adjusting brakes.

The disc-type brakes self-adjust every time the brake pedal is applied.



WARNING

Have your brake system checked if the brake pedal height does not return to normal. It is recommended you visit a NISSAN dealer for this service.

BRAKE PAD WEAR WARNING

The disc brake pads have audible wear warnings. When a brake pad requires replacement, it will make a high pitched scraping sound when the vehicle is in motion. This scraping sound will first occur only when the brake pedal is depressed. After more wear of the brake pad, the sound will always be heard even if the brake pedal is not depressed. Have the brakes checked as soon as possible if the wear warning sound is heard.

Under some driving or climate conditions,

occasional brake squeak, squeal or other noise may be heard. Occasional brake noise during light to moderate stops is normal and does not affect the function or performance of the brake system.

Proper brake inspection intervals should be followed. For additional information, see the maintenance schedule shown in the "9. Maintenance and schedules" section.

FUSES

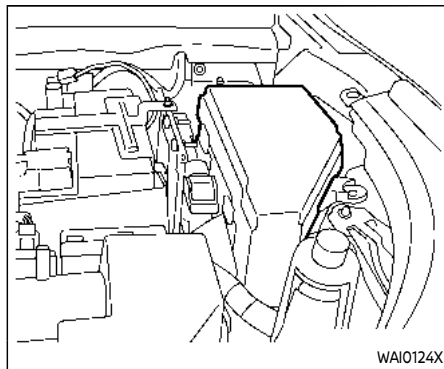

ENGINE COMPARTMENT



WARNING

Never use a fuse of a higher or lower amperage rating than that specified on the fuse box cover. This could damage the electrical system or electronic control units or cause a fire.

If any electrical equipment does not operate, check for an open fuse.

1. Be sure the ignition switch is turned off and the headlights are off.

2. Open the engine hood.
3. Remove the fuse/fusible link box cover by using a suitable tool and pushing the tab.
4. Locate the fuse that needs to be replaced.
5. Remove the fuse using the fuse puller located in the passenger compartment fuse box.

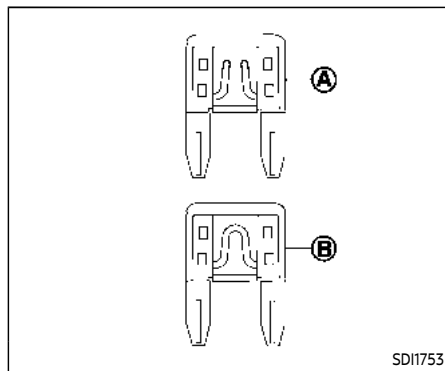

6. If the fuse is open **A**, replace it with a new fuse **B**.
7. If a new fuse also opens, have the electrical system checked and repaired. It is recommended you visit a NISSAN dealer for this service.

Fusible links

If any electrical equipment does not operate and the fuses are in good condition, check the fusible links. If any of these fusible links are melted, replace only with genuine NISSAN parts.

For checking and replacing the fusible links, it is recommended you visit a NISSAN dealer.

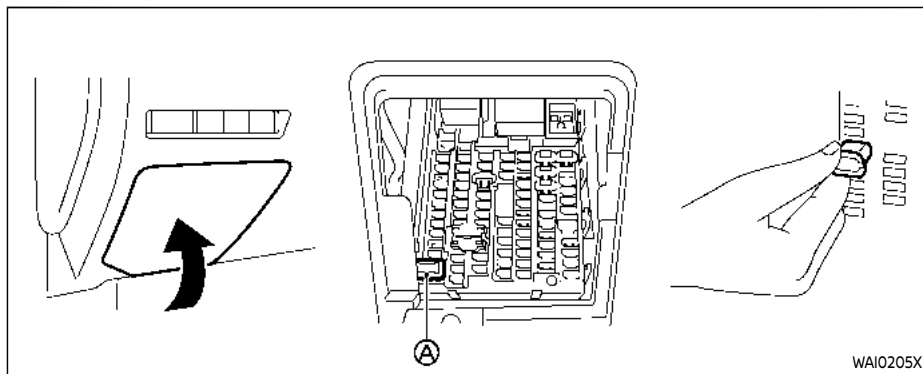

WAI0205X

PASSENGER COMPARTMENT

WARNING

Never use a fuse of a higher or lower amperage rating than that specified on the fuse box cover. This could damage the electrical system or electronic control units or cause a fire.



If any electrical equipment does not operate, check for an open fuse.

1. Be sure the ignition switch is turned off and the headlights are off.

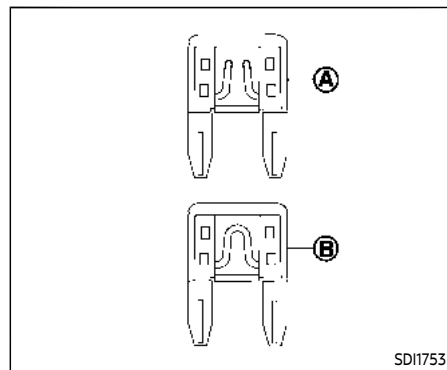
2. Remove the fuse box cover.
3. Remove the fuse with the fuse puller .



SDI1753

4. If the fuse is open , replace it with a new fuse .
5. If a new fuse also opens, have the electrical system checked and repaired. It is recommended you visit a NISSAN dealer for this service.

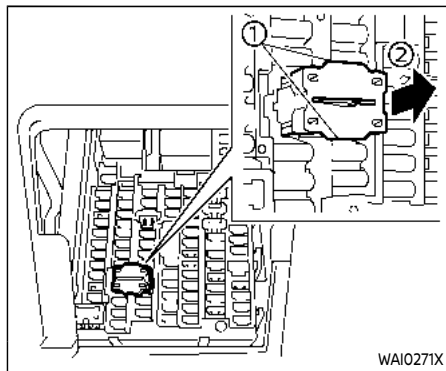

How to remove the extended storage switch:

1. To remove the extended storage switch, be sure the ignition switch is in the OFF or LOCK position.
2. Be sure the headlights are off. (See "Headlight switch" (P.2-58) or "Intelligent Auto Headlight system" (P.2-59).)
3. Remove the fuse box cover.
4. Pinch the locking tabs ① on top and bottom of the extended storage switch.
5. Pull the extended storage switch straight out from the fuse box ②.

Extended storage switch (if so equipped)

The extended storage switch is used when shipping the vehicle. It is located in the fuse panel on the driver's side of the instrument panel. If any electrical equipment does not operate, ensure the extended storage switch is pushed fully in place.

To inspect the extended storage switch, ensure the ignition switch and headlights are off.



CAUTION

- Be careful not to allow children to swallow the battery and removed parts.
- An improperly disposed battery can harm the environment. Always confirm local regulations for battery disposal.
- When changing batteries, do not let dust or oil get on the components.
- There is danger of explosion if the lithium battery is incorrectly replaced. Replace only with the same or equivalent type.

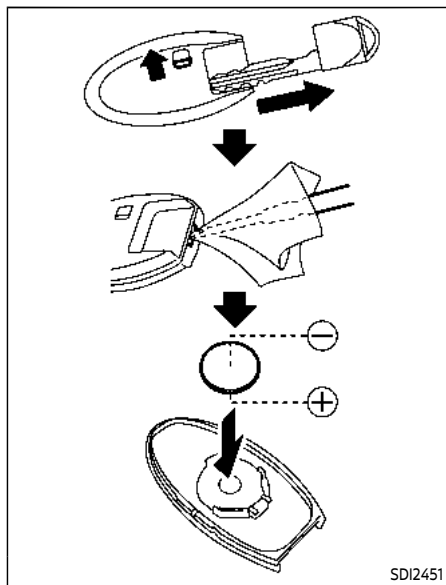

Replace the battery in the Intelligent Key as follows:

1. Remove the mechanical key from the Intelligent Key.
2. Insert a small screwdriver into the slit of the corner and twist it to separate the upper part from the lower part.

Use a cloth to protect the casing.

3. Replace the battery with a new one.

Recommended battery:

CR2032 or equivalent

- Do not touch the internal circuit and electric terminals as doing so could cause a malfunction.
- Hold the battery by the edges. Holding the battery across the contact points will seriously deplete the storage capacity.
- Make sure that the \oplus side faces the bottom of the case.

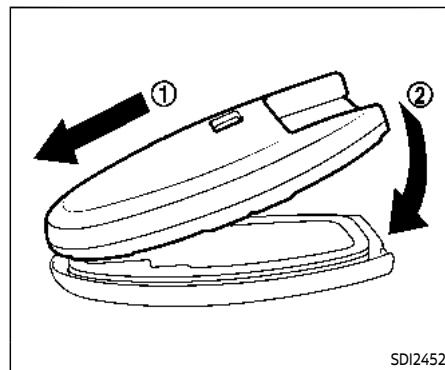

4. Align the tips of the upper and lower parts ①, and then push them together ② until it is securely closed.
5. Operate the buttons to check its operation.

If you need any assistance for replacement, it is recommended you visit a NISSAN dealer for this service.

FCC Notice:

For USA:

FCC ID : KR5TXN1

FCC ID : KR5TXN3

FCC ID : KR5TXN4

FCC ID : KR5HFM401

This device complies with Part 15 of the FCC Rules. Operation is subject to the following two conditions: (1) This device may not cause harmful interference, and (2) this device must accept any interference received, including interference that may cause undesired operation.

Note: Changes or modifications not expressly approved by the party responsible for compliance could void the user's authority to operate the equipment.

For Canada:

IC ID : 7812D-TXN1

IC ID : 7812D-TXN3

IC ID : 7812D-TXN4

IC ID : 7812D-HFM401

This device complies with Industry Canada licence-exempt RSS standard(s). Operation is subject to the following two conditions: (1) this device may not cause interference, and (2) this device must accept any interference, including interference that may cause undesired operation of the device.

LIGHTS

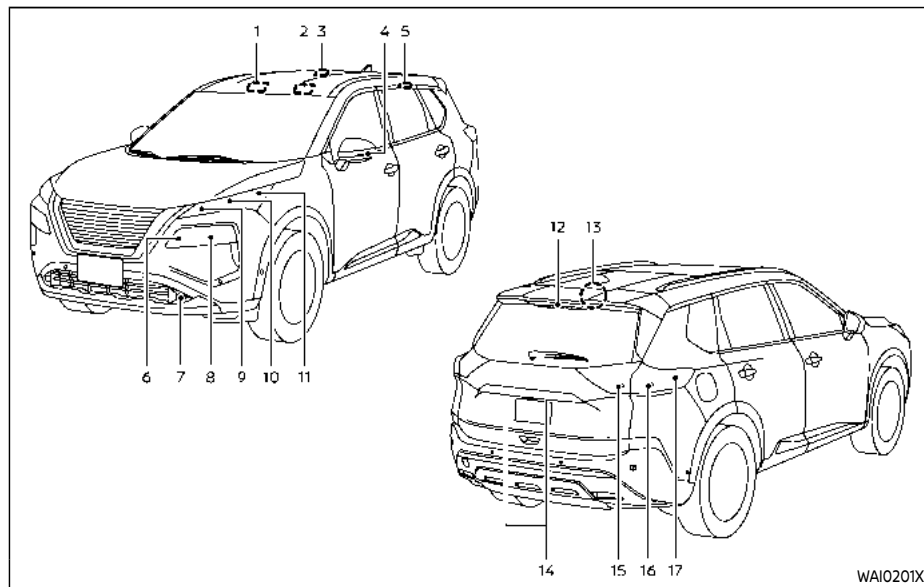

14. License plate light
15. Back-up light/Tail light
16. Rear turn signal light/Stop light/Tail light
17. Rear side marker light

1. Front map light
2. Vanity mirror light
3. Room light (if so equipped)
4. Side turn signal light
5. Rear personal light (if so equipped)
6. Headlight (high-beam)
7. Front fog light (if so equipped)
8. Headlight (low-beam)
9. Front parking light/Daytime running light/Front turn signal light (LED type)
10. Front turn signal light (Bulb type)
11. Front side marker light
12. High-mounted stop light
13. Cargo light

HEADLIGHTS

Fog may temporarily form inside the lens of the exterior lights in the rain or in a car wash. A temperature difference between the inside and the outside of the lens causes the fog. This is not a malfunction. If large drops of water collect inside the lens, it is recommended you visit a NISSAN dealer for servicing.

Replacing

If LED headlight replacement is required, it is recommended that you visit a NISSAN dealer for this service.



EXTERIOR AND INTERIOR LIGHTS

Item	Wattage (w)	Bulb No.
Headlight high/low beams*	LED	-
Front turn signal light*	28/8 or LED	7444NA or -
Front parking light*	LED	-
Front side marker light*	5	W5W
Front fog light (if so equipped)*	LED	-
Side turn signal light (if so equipped)*	LED	-
Daytime running light*	LED	-
Rear combination light*		
Turn signal light	21	W21W
Stop/tail light	LED	-
Back-up	16	W16W
Rear side marker light*	5	W5W
License plate light*	5 (assembly)	W5W
Map light*	8	W8W
Rear personal light (if so equipped)*	5	W5W
Vanity mirror light*	5	W5W
High-mounted stop light*	LED	-
Room light (if so equipped)*	8	W8W
Cargo light	8	-
Lower center light (if so equipped)*	1.4	-
Console box light*	1.4 or LED	-

*: It is recommended you visit a NISSAN dealer for replacement.

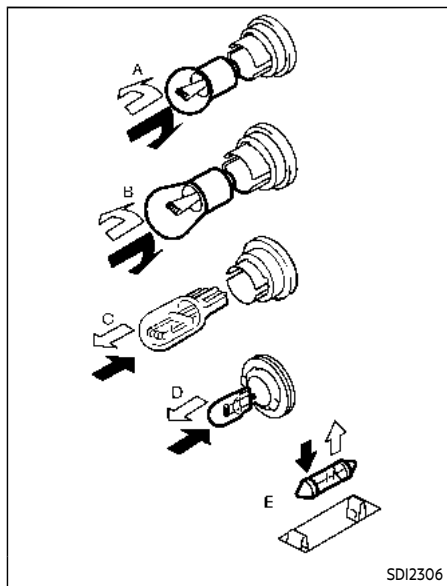
NOTE: It is recommended that you check with the Parts Department at a NISSAN dealer for the latest information about parts.



 REMOVE
 INSTALL

Replacement procedures

All other lights are either type A, B, C, D or E. When replacing a bulb, first remove the lens and/or cover.

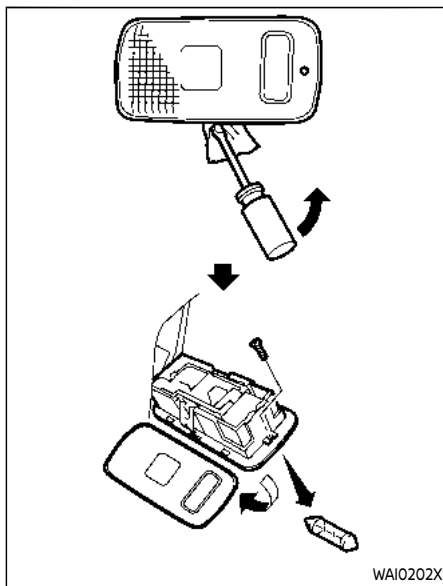

Cargo light

WHEELS AND TIRES

If you have a flat tire, see “Flat tire” (P.6-3).

TIRE PRESSURE

Tire Pressure Monitoring System (TPMS)

This vehicle is equipped with the Tire Pressure Monitoring System (TPMS). It monitors tire pressure of all tires except the spare. When the low tire pressure warning light is lit, and the “Tire Pressure Low - Add Air” warning message is displayed in the vehicle information display, one or more of your tires is significantly under-inflated.

The TPMS will activate only when the vehicle is driven at speeds above 16 MPH (25 km/h). Also, this system may not detect a sudden drop in tire pressure (for example a flat tire while driving).

For more details, see “Low tire pressure warning light” (P.2-18), “Tire Pressure Monitoring System (TPMS)” (P.5-6) and “Tire Pressure Monitoring System (TPMS)” (P.6-3).

Tire inflation pressure

Check the pressure of the tires (including the spare) often and always prior to long distance trips. The recommended tire pressure specifications are shown on the Tire and Loading Information label under the “Cold Tire Pressure” heading. The Tire and Loading Information label is affixed to the driver side center pillar. Tire pressures should be checked regularly because:

- Most tires naturally lose air over time.
- Tires can lose air suddenly when driven over potholes or other objects or if the vehicle strikes a curb while parking.

The tire pressures should be checked when the tires are cold. The tires are considered COLD after the vehicle has been parked for 3 or more hours, or driven less than 1 mile (1.6 km) at moderate speeds.

TPMS with Easy Fill Tire Alert provides visual and audible signals

outside the vehicle for inflating the tires to the recommended COLD tire pressure. (See “TPMS with Easy Fill Tire Alert” (P.5-9).)

Incorrect tire pressure, including under inflation, may adversely affect tire life and vehicle handling.



WARNING

- **Improperly inflated tires can fail suddenly and cause an accident.**
- **The Gross Vehicle Weight rating (GVWR) is located on the F.M.V.S.S./C.M.V.S.S. certification label. The vehicle weight capacity is indicated on the Tire and Loading Information label. Do not load your vehicle beyond this capacity. Overloading your vehicle may result in reduced tire life, unsafe operating conditions due to premature tire failure, or unfavorable**

handling characteristics and could also lead to a serious accident. Loading beyond the specified capacity may also result in failure of other vehicle components.

- Before taking a long trip, or whenever you heavily load your vehicle, use a tire pressure gauge to ensure that the tire pressures are at the specified level.
- For additional information regarding tires, refer to “Important Tire Safety Information” (US) or “Tire Safety Information” (Canada) in the Warranty Information Booklet.

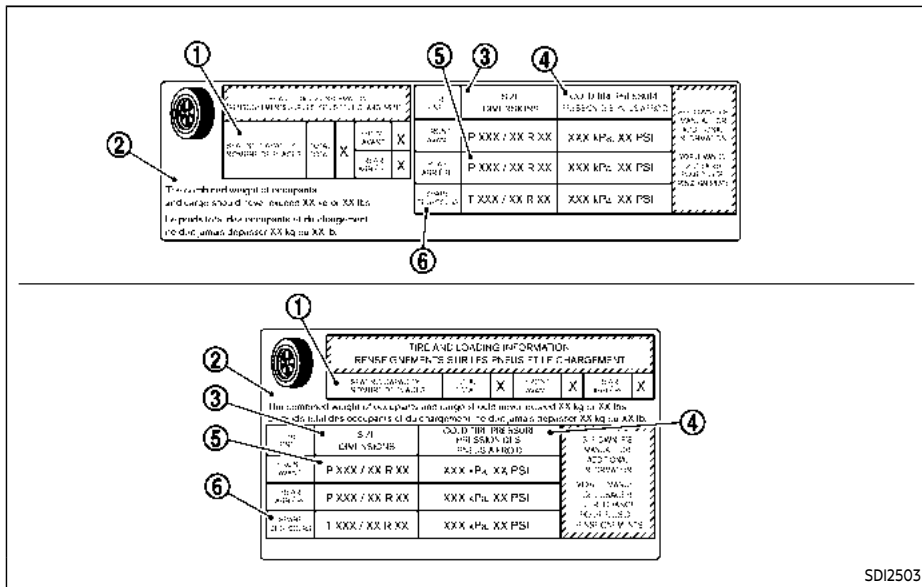

- ④ Cold tire pressure: Inflate the tires to this pressure when the tires are cold. Tires are considered COLD after the vehicle has been parked for 3 or more hours, or driven less than 1 mile (1.6 km) at moderate speeds. The recommended cold tire inflation is set by the manufacturer to provide the best balance of tire wear, vehicle handling, driveability, tire noise, etc., up to the vehicle's GVWR.
- ⑤ Tire size — see "Tire labeling" (P.8-34).
- ⑥ Spare tire size or compact spare tire size

Tire and Loading Information label

- ① Seating capacity: The maximum number of occupants that can be seated in the vehicle.
- ② Vehicle load limit: See "Ve-

hicle loading information" (P.10-15).

- ③ Original size: The size of the tires originally installed on the vehicle at the factory.

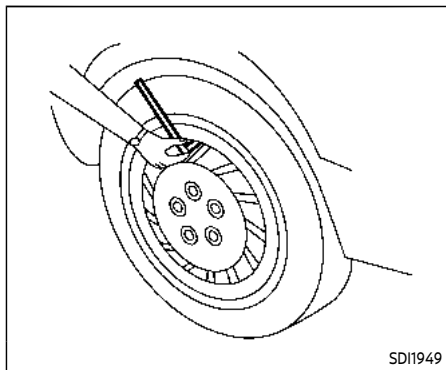

Checking the tire pressure

1. Remove the valve stem cap from the tire.
2. Press the pressure gauge squarely onto the valve stem. Do not press too hard or force the valve stem sideways, or air will escape. If the hissing sound of air escaping from the tire is heard while checking the pressure, reposition the gauge to eliminate this leakage.
3. Remove the gauge.
4. Read the tire pressure on the gauge stem and compare it to the specification shown on the Tire and Loading Information label.
5. Add air to the tire as needed. If too much air is added, press the core of the valve stem briefly with the tip of the gauge stem to release pressure. Recheck the pressure and add or release air as needed.
6. Install the valve stem cap.
7. Check the pressure of all other tires, including the spare.

	SIZE	COLD TIRE INFLATION PRESSURE
FRONT ORIGINAL TIRE	235/65 R17	250 kPa, 36 PSI
	235/60 R18	230 kPa, 33 PSI
	235/55 R19	230 kPa, 33 PSI
REAR ORIGINAL TIRE	235/65 R17	230 kPa, 33 PSI
	235/60 R18	210 kPa, 30 PSI
	235/55 R19	210 kPa, 30 PSI
SPARE TIRE	T155/80 D17 (2WD) T165/90 D17 (AWD)	420 kPa, 60 PSI

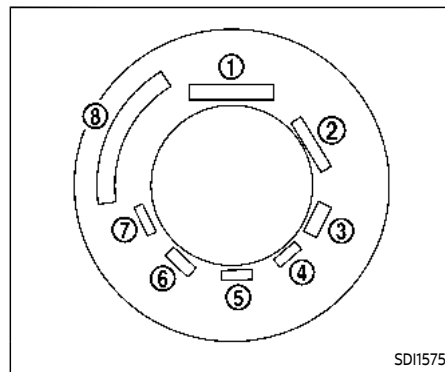

Example

SD11575

TIRE LABELING

Federal law requires tire manufacturers to place standardized information on the sidewall of all tires. This information identifies and describes the fundamental characteristics of the tire and also provides the tire identification number (TIN) for safety standard certification. The TIN can be used to identify the tire in case of a recall.

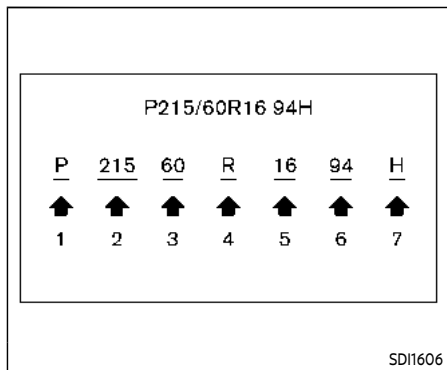

Example

① Tire size (example: P215/60R16 94H)

1. P: The "P" indicates the tire is designed for passenger vehicles. (Not all tires have this information.)
2. Three-digit number (215): This number gives the width in millimeters of the tire from sidewall edge to sidewall edge.
3. Two-digit number (60): This number, known as the aspect ratio, gives the tire's ratio of

height to width.

4. R: The "R" stands for radial.
5. Two-digit number (16): This number is the wheel or rim diameter in inches.
6. Two- or three-digit number (94): This number is the tire's load index. It is a measurement of how much weight each tire can support. You may not find this information on all tires because it is not required by law.
7. H: Tire speed rating. You should not drive the vehicle faster than the tire speed rating.

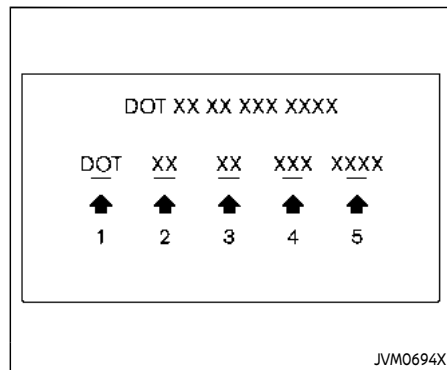

Example

② TIN (Tire Identification Number) for a new tire (example: DOT XX XX XXX XXXX)

1. DOT: Abbreviation for the "Department of Transportation". The symbol can be placed above, below or to the left or right of the Tire Identification Number.
2. Two-digit code: Manufacturer's identification mark
3. Two-digit code: Tire size

4. Three-digit code: Tire type code (Optional)

5. Four numbers represent the week and year the tire was built. For example, the numbers 3103 means the 31st week of 2003. If these numbers are missing, then look on the other sidewall of the tire.

③ Tire ply composition and material

The number of layers or plies of rubber-coated fabric in the tire.

Tire manufacturers also must indicate the materials in the tire, which include steel, nylon, polyester, and others.

④ Maximum permissible inflation pressure

This number is the greatest amount of air pressure that should be put in the tire. Do not exceed the maximum permissible inflation pressure.

⑤ Maximum load rating

This number indicates the maxi-

mum load in kilograms and pounds that can be carried by the tire. When replacing the tires on the vehicle, always use a tire that has the same load rating as the factory installed tire.

⑥ Term of “tubeless” or “tube type”
Indicates whether the tire requires an inner tube (“tube type”) or not (“tubeless”).

⑦ The word “radial”

The word “radial” is shown, if the tire has radial structure.

⑧ Manufacturer or brand name
Manufacturer or brand name is shown.

Other tire-related terminology:

In addition to the many terms that are defined throughout this section, Intended Outboard Sidewall is (1) the sidewall that contains a whitewall, bears white lettering or bears manufacturer, brand and/or model name molding that is higher or deeper than the same molding on the other sidewall of the tire, or

(2) the outward facing sidewall of an asymmetrical tire that has a particular side that must always face outward when mounted on a vehicle.

TYPES OF TIRES



WARNING

- **When changing or replacing tires, be sure all four tires are of the same type (Example: Summer, All Season or Snow) and construction. A NISSAN dealer may be able to help you with information about tire type, size, speed rating and availability.**
- **Replacement tires may have a lower speed rating than the factory equipped tires, and may not match the potential maximum vehicle speed. Never exceed the maximum speed rating of the tire.**
- **Replacing tires with those not originally specified by NISSAN could affect the proper operation of the TPMS.**

- For additional information regarding tires, refer to “Important Tire Safety Information” (US) or “Tire Safety Information” (Canada) in the Warranty Information Booklet.
- Always use tires of the same type, size, brand, construction and tread pattern on all four wheels. Failure to do so may result in a circumference difference between tires on the front and rear axles which can cause the Vehicle Dynamic Control (VDC) system to malfunction resulting in personal injury or death, excessive tire wear and may damage the transmission, transfer case and differential gears.

All season tires

NISSAN specifies all season tires on some models to provide good performance all year, including snowy and icy road conditions. All Season tires are identified by ALL SEASON and/or M&S (Mud and Snow) on the tire sidewall. Snow tires have better snow traction than All Season tires and may be more appropriate in some areas.

Summer tires

NISSAN specifies summer tires on some models to provide superior performance on dry roads. Summer tire performance is substantially reduced in snow and ice. Summer tires do not have the tire traction rating M&S on the tire sidewall.

If you plan to operate your vehicle in snowy or icy conditions, NISSAN recommends the use of SNOW tires or ALL SEASON tires on all four wheels.

Snow tires

If snow tires are needed, it is necessary to select tires equivalent in size and load rating to the original equipment tires. If you do not, it can adversely affect the safety and handling of your vehicle.

Generally, snow tires will have lower speed ratings than factory equipped tires and may not match the potential maximum vehicle speed. Never exceed the maximum speed rating of the tire.

If you install snow tires, they must be the same size, brand, construction and tread pattern on all four wheels.

For additional traction on icy roads, studded tires may be used. However, some U.S. states and Canadian provinces prohibit their use. Check local, state and provincial laws before installing studded

tires. Skid and traction capabilities of studded snow tires, on wet or dry surfaces, may be poorer than that of non-studded snow tires.

TIRE CHAINS



WARNING

If tire chains are used with this vehicle, they must allow sufficient clearance between the tire and the closest vehicle suspension or body component. Failure to use the correct chains, or not properly installing chains, can damage the brakes, suspension or other vehicle parts and cause a crash in which a person could be seriously injured or killed. NISSAN recommends using the following chains, or equivalent.

- PEERLESS SUPER Z6 SZ-429

Use of tire chains may be prohibited according to location. Check the local laws before installing tire chains. When installing tire chains, make sure they are the proper size for the tires on your vehicle and are installed according to the chain manufacturer's suggestions. **Use only SAE Class S chains.** Class “S” chains are used on vehicles with re-

stricted tire to vehicle clearance. Vehicles that can use Class "S" chains are designed to meet the SAE standard minimum clearances between the tire and the closest vehicle suspension or body component required to accommodate the use of a winter traction device (tire chains or cables). The minimum clearances are determined using the factory equipped tire size. Other types may damage your vehicle. Use chain tensioners when recommended by the tire chain manufacturer to ensure a tight fit. Loose end links of the tire chain must be secured or removed to prevent the possibility of whipping action damage to the fenders or underbody. If possible, avoid fully loading your vehicle when using tire chains. In addition, drive at a reduced speed. Otherwise, your vehicle may be damaged and/or vehicle handling and performance may be adversely affected.

Tire chains must be installed only on the front wheels and not on the rear wheels.

Never install tire chains on a TEMPORARY USE ONLY spare tire.

Do not use tire chains on dry roads. Driving with tire chains in such conditions can cause damage to the various mechanisms of the vehicle due to some overstress.

8-38 **Do-it-yourself**

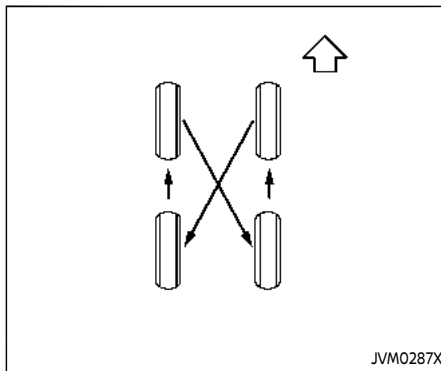

CHANGING WHEELS AND TIRES

Tire rotation

NISSAN recommends rotating the tires at the specified interval shown in the maintenance schedule. (See the "Maintenance and schedules" section. For tire replacing procedures, see "Flat tire" (P.6-3).)

As soon as possible, tighten the wheel nuts to the specified torque with a torque wrench.

Wheel nut tightening torque:

83 ft-lb (113 N·m)

The wheel nuts must be kept tightened to the specification at all times. It is recommended that wheel nuts be tightened to the specification at each tire rotation interval.

WARNING

- **Retighten the wheel nuts when the vehicle has been driven for 600 miles (1,000 km) (also in cases of a flat tire, etc.).**
- **Do not include the spare tire in the tire rotation.**
- **For additional information regarding tires, refer to "Important Tire Safety Information" (US) or "Tire Safety Information" (Canada) in the Warranty Information Booklet.**

- After rotating the tires, do not use the Easy-Fill Tire Alert to adjust the tire pressure. Instead use a gauge to adjust the tires to the correct pressure in accordance with Tire and Loading Information label.
- To ensure proper operation of the Easy-Fill Tire Alert system after a tire rotation, reset and register the sensor to their new installed locations. It is recommended that you visit a NISSAN dealer for this service.

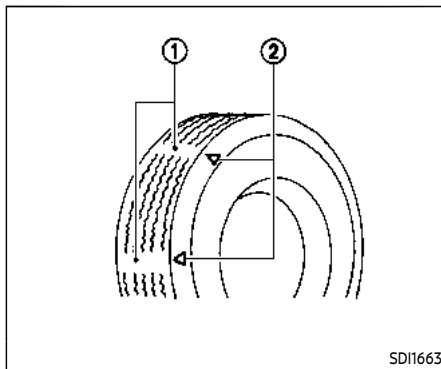

1. Wear indicator
2. Wear indicator location mark

Tire wear and damage

WARNING

- Tires should be periodically inspected for wear, cracking, bulging or objects caught in the tread. If excessive wear, cracks, bulging or deep cuts are found, the tire(s) should be replaced.

- The original tires have built-in tread wear indicators. When wear indicators are visible, the tire(s) should be replaced.
- Tires degrade with age and use. Have tires, including the spare, over 6 years old checked by a qualified technician, because some tire damage may not be obvious. Replace the tires as necessary to prevent tire failure and possible personal injury.
- Improper service of the spare tire may result in serious personal injury. If it is necessary to repair the spare tire, it is recommended you visit a NISSAN dealer for this service.
- For additional information regarding tires, refer to "Important Tire Safety Information" (US) or "Tire Safety Information" (Canada) in the

Warranty Information Booklet.

Replacing wheels and tires

When replacing a tire, use the same size, tread design, speed rating and load carrying capacity as originally equipped. (See "Specifications" (P.10-9) for recommended types and sizes of tires and wheels.)



WARNING

- The use of tires other than those recommended or the mixed use of tires of different brands, construction (bias, bias-belted or radial), or tread patterns can adversely affect the ride, braking, handling, VDC system, ground clearance, body-to-tire clearance, tire chain clearance, speedometer calibration, headlight aim and bumper height. Some of these effects may lead to accidents and could result in serious personal injury.
- For Two-Wheel Drive (2WD) models, if your vehicle was originally equipped with 4 tires that were

the same size and you are only replacing 2 of the 4 tires, install the new tires on the rear axle. Placing new tires on the front axle may cause loss of vehicle control in some driving conditions and cause an accident and personal injury.

- If the wheels are changed for any reason, always replace with wheels which have the same offset dimension. Wheels of a different off-set could cause premature tire wear, degrade vehicle handling characteristics and/or interference with the brake discs/drums. Such interference can lead to decreased braking efficiency and/or early brake pad/shoe wear. See "Wheels and tires" (P.10-10) of this manual for wheel off-set dimensions.
- Since the spare tire is not equipped with the TPMS, when a spare tire is mounted or a wheel is replaced, the TPMS will not function and the low tire pressure warning light will flash for approximately 1 minute. The light will remain on after 1 minute. Have your tires replaced and/or TPMS system reset as soon as

possible. It is recommended you visit a NISSAN dealer for these services.

- Replacing tires with those not originally specified by NISSAN could affect the proper operation of the TPMS.
- The TPMS sensor may be damaged if it is not handled correctly. Be careful when handling the TPMS sensor.
- When replacing the TPMS sensor, the ID registration may be required. It is recommended you visit a NISSAN dealer for ID registration.
- Do not use a valve stem cap that is not specified by NISSAN. The valve stem cap may become stuck.
- Be sure that the valve stem caps are correctly fitted. Otherwise the valve may be clogged up with dirt and cause a malfunction or loss of pressure.
- Do not install a damaged or deformed wheel or tire even if it has been repaired. Such wheels or tires could have structural damage and could fail without warning.

- **The use of retread tire is not recommended.**
- **For additional information regarding tires, refer to “Important Tire Safety Information” (US) or “Tire Safety Information” (Canada) in the Warranty Information Booklet.**

All-Wheel Drive (AWD) models

CAUTION

- **Always use tires of the same size, brand, construction (bias, bias-belted or radial), and tread pattern on all four wheels. Failure to do so may result in a circumference difference between tires on the front and rear axles which will cause excessive tire wear and may damage the transmission and the drivetrain parts.**
- **Only use spare tires specified for each AWD model.**

If excessive tire wear is found, it is recommended that all four tires be replaced with tires of the same size, brand, construction and tread pattern. The tire

pressure and wheel alignment should also be checked and corrected as necessary. It is recommended you visit a NISSAN dealer for this service.

Wheel balance

Unbalanced wheels may affect vehicle handling and tire life. Even with regular use, wheels can get out of balance. Therefore, they should be balanced as required.

Wheel balance service should be performed with the wheels off the vehicle. Spin balancing the wheels on the vehicle could lead to mechanical damage.

For additional information regarding tires, refer to “Important Tire Safety Information” (US) or “Tire Safety Information” (Canada) in the Warranty Information Booklet.

Care of wheels

See “Cleaning exterior” (P.7-2) for details about care of the wheels.

Spare tire

Since the spare tire is not equipped with the TPMS, when a spare tire is mounted (TEMPORARY USE ONLY), the TPMS will not function.

Observe the following precautions if the TEMPORARY USE ONLY spare tire must be

used, otherwise your vehicle could be damaged or involved in an accident.



WARNING

- **The TEMPORARY USE ONLY spare tire should be used for emergency use. It should be replaced with the standard tire at the first opportunity to avoid possible tire or differential damage.**
- **Drive carefully while the TEMPORARY USE ONLY spare tire is installed. Avoid sharp turns and abrupt braking while driving.**
- **Periodically check spare tire inflation pressure. Always keep the pressure of the TEMPORARY USE ONLY spare tire at 60 psi (420 kPa, 4.2 bar).**
- **With the TEMPORARY USE ONLY spare tire installed, do not drive your vehicle at speeds faster than 50 MPH (80 km/h).**
- **When driving on roads covered with snow or ice, the TEMPORARY USE ONLY spare tire should be used on the rear wheels and original tire used on the front wheels (drive wheels). Use tire chains only on the front (original)**

tires.

- **Tire tread of the TEMPORARY USE ONLY spare tire will wear at a faster rate than the standard tire. Replace the spare tire as soon as the tread wear indicators appear.**
- **Do not use the spare tire on other vehicles.**
- **Do not use more than one spare tire at the same time.**
- **Do not tow a trailer when the TEMPORARY USE ONLY spare tire is installed.**



CAUTION

- **Do not use tire chains on a TEMPORARY USE ONLY spare tire. Tire chains will not fit properly and may cause damage to the vehicle.**
- **Because the TEMPORARY USE ONLY spare tire is smaller than the original tire, ground clearance is reduced. To avoid damage to the vehicle, do not drive over obstacles. Also do not drive the vehicle through an automatic car wash since it may get caught.**

9 Maintenance and schedules

Maintenance requirement	9-2	Chassis and body maintenance	9-6
General maintenance	9-2	Maintenance schedules	9-7
Scheduled maintenance	9-2	Additional maintenance items for severe operating conditions	9-7
Where to go for service	9-2	Oil control system	9-7
General maintenance	9-2	Standard maintenance	9-8
Explanation of general maintenance items	9-2	PR25DD engine model	9-8
Explanation of scheduled maintenance items	9-5	KR15DDT engine model	9-20
Emission control system maintenance	9-5		

MAINTENANCE REQUIREMENT

Some day-to-day and regular maintenance is essential to maintain your vehicle good mechanical condition, as well as its emission and engine performance.

It is the owner's responsibility to make sure that the scheduled maintenance, as well as general maintenance, is performed.

As the vehicle owner, you are the only one who can ensure that your vehicle receives the proper maintenance care. You are a vital link in the maintenance chain.

GENERAL MAINTENANCE

General maintenance includes those items which should be checked during normal day-to-day operation. They are essential for proper vehicle operation. It is your responsibility to perform these procedures regularly as prescribed.

Performing general maintenance checks requires minimal mechanical skill and only a few general automotive tools.

These checks or inspections can be done by yourself, a qualified technician or, if you prefer, a NISSAN dealer.

SCHEDULED MAINTENANCE

The maintenance items listed in this section are required to be serviced at regular intervals. However, under severe driving conditions, additional or more frequent maintenance will be required.

WHERE TO GO FOR SERVICE

If maintenance service is required or your vehicle appears to malfunction, have the systems checked and serviced. It is recommended you visit a NISSAN dealer for this service.

NISSAN technicians are well-trained specialists and are kept up-to-date with the latest service information through technical bulletins, service tips, and training programs. They are completely qualified to work on NISSAN vehicles **before** work begins.

If your vehicle is involved in a collision, it is recommended that you ask your NISSAN dealer where the nearest NISSAN Certified Collision Center is located, or go to <http://collision.nissanusa.com>.

You can be confident that a NISSAN dealer's service department performs the best job to meet the maintenance requirements on your vehicle.

GENERAL MAINTENANCE

During the normal day-to-day operation of the vehicle, general maintenance should be performed regularly as prescribed in this section. If you detect any unusual sounds, vibrations or smells, be sure to check for the cause or have it checked promptly. In addition, it is recommended that you visit a NISSAN dealer if you think that repairs are required.

When performing any checks or maintenance work, see "Maintenance precautions" (P.8-2).

EXPLANATION OF GENERAL MAINTENANCE ITEMS

Additional information on the following items with "" is found in the "8. Do-it-yourself" section of this manual.

Outside the vehicle

The maintenance items listed here should be performed from time to time, unless otherwise specified.

Doors and engine hood: Check that all doors and the engine hood operate properly. Also ensure that all latches lock securely. Lubricate hinges, latches, latch pins, rollers and links if necessary. Make sure that the secondary latch keeps the hood from opening when the primary latch is released.

When driving in areas using road salt or

other corrosive materials, check lubrication frequently.

Lights*: Clean the headlights on a regular basis. Make sure that the headlights, stop lights, tail lights, turn signal lights, and other lights are all operating properly and installed securely. Also check headlight aim.

Road wheel nuts (lug nuts)*: When checking the tires, make sure no wheel nuts are missing, and check for any loose wheel nuts. Tighten if necessary.

Tire rotation*: Rotate tires at the specified interval shown in the maintenance schedule.

Tires*: Check the pressure with a gauge often and always prior to long distance trips. If necessary, adjust the pressure in all tires, including the spare (if so equipped), to the pressure specified. Check carefully for damage, cuts or excessive wear.

Tire Pressure Monitoring System (TPMS) tire pressure sensor: It is recommended that you replace TPMS tire pressure sensor assembly when the tires are replaced due to wear or age.

Wheel alignment and balance: If the vehicle should pull to either side while driving on a straight and level road, or if you detect uneven or abnormal tire wear,

there may be a need for wheel alignment. If the steering wheel or seat vibrates at normal highway speeds, wheel balancing may be needed.

For additional information regarding tires, refer to "Important Tire Safety Information" (US) or "Tire Safety Information" (Canada) in the NISSAN Warranty Information Booklet.

Windshield: Clean the windshield on a regular basis. Check the windshield at least every six months for cracks or other damage. Have a damaged windshield repaired by a qualified repair facility.

It is recommended that you have a damaged windshield repaired by a NISSAN dealer, or a NISSAN Certified Collision Center. To locate a collision center in your area, refer to <http://collision.nissanusa.com>.

Windshield wiper blades*: Check for cracks or wear if they do not wipe properly.

Inside the vehicle

The maintenance items listed here should be checked on a regular basis, such as when performing scheduled maintenance, cleaning the vehicle, etc.

Accelerator pedal: Check the pedal for smooth operation and make sure the

pedal does not catch or require uneven effort. Keep the floor mat away from the pedal.

Brake pedal: Check the pedal for smooth operation. If the brake pedal suddenly goes down further than normal, the pedal feels spongy or the vehicle seems to take longer to stop, have your vehicle checked immediately. It is recommended you visit a NISSAN dealer for this service. Keep the floor mat away from the pedal.

Brakes: Check that the brakes do not pull the vehicle to one side when applied.

Continuously Variable Transmission (CVT) P (Park) mechanism: On a fairly steep hill, check that the vehicle is held securely with the shift lever in the P (Park) position without applying any brakes.

Parking brake: Check the parking brake operation regularly. The vehicle should be securely held on a fairly steep hill with only the parking brake applied. If the parking brake needs adjusted, it is recommended you visit a NISSAN dealer for this service.

Seat belts: Check that all parts of the seat belt system (for example, buckles, anchors, adjusters and retractors) operate properly and smoothly, and are installed securely. Check the belt webbing for cuts, fraying, wear or damage.

Seats: Check seat position controls such as seat adjusters, seatback recliners, etc. to ensure they operate smoothly and that all latches lock securely in every position. Check that the head restraints/headrests move up and down smoothly and that the locks (if so equipped) hold securely in all latched positions.

Steering wheel: Check for changes in the steering conditions, such as excessive free play, hard steering or strange noises.

Warning lights and chimes: Make sure that all warning lights and chimes are operating properly.

Windshield defroster: Check that the air comes out of the defroster outlets properly and in sufficient quantity when operating the heater or air conditioner.

Windshield wiper and washer*: Check that the wipers and washers operate properly and that the wipers do not streak.

Under the hood and vehicle

The maintenance items listed here should be checked periodically (for example, each time you check the engine oil or refuel).

Battery*: This vehicle is equipped with a sealed maintenance free battery. It is recommended that you visit a NISSAN

dealer for service.

NOTE:

Care should be taken to avoid situations that can lead to potential battery discharge and potential no-start conditions such as:

1. **Installation or extended use of electronic accessories that consume battery power when the engine is not running (Phone chargers, GPS, DVD players, etc.)**
2. **Vehicle is not driven regularly and/or only driven short distances.**

In these cases, the battery may need to be charged to maintain battery health.

Brake fluid level*: Make sure that the brake fluid level is between the MAX and MIN lines on the reservoir.

Engine coolant level*: Check the coolant level when the engine is cold.

Intercooler coolant level*: Check the coolant level when the engine is cold.

Engine drive belt*: Make sure that the drive belt is not frayed, worn, cracked or oily.

Engine oil level*: Check the level after parking the vehicle on a level surface and turning off the engine. Wait more than 10 minutes for the oil to drain back into the oil pan.

Exhaust system: Make sure there are no loose supports, cracks or holes. If the sound of the exhaust seems unusual or there is a smell of exhaust fumes, immediately have the exhaust system inspected. It is recommended you visit a NISSAN dealer for this service. (See "Precautions when starting and driving" (P.5-5) for exhaust gas (carbon monoxide).)

Fluid leaks: Check under the vehicle for fuel, oil, water or other fluid leaks after the vehicle has been parked for a while. Water dripping from the air conditioner after use is normal. If you should notice any leaks or if gasoline fumes are evident, check for the cause and have it corrected immediately.

Radiator and hoses: Check the front of the radiator and clean off any dirt, insects, leaves, etc., that may have accumulated. Make sure the hoses have no cracks, deformation, rot or loose connections.

Underbody: The underbody is frequently exposed to corrosive substances such as those used on icy roads or to control dust. It is very important to remove these substances, otherwise rust will form on the floor pan, frame, fuel lines and around the exhaust system. At the end of winter, the underbody should be thoroughly flushed with plain water, being careful to clean those areas where mud and dirt

EXPLANATION OF SCHEDULED MAINTENANCE ITEMS

may accumulate. For additional information, see "Cleaning exterior" (P.7-2).

Windshield washer fluid*: Check that there is adequate fluid in the reservoir.

The following descriptions are provided to give you a better understanding of the scheduled maintenance items that should be regularly checked or replaced. The maintenance schedule indicates at which mileage/time intervals each item requires service.

In addition to scheduled maintenance, your vehicle requires that some items be checked during normal day-to-day operation. Refer to "General maintenance" (P.9-2).

Items marked with "*" are recommended by NISSAN for reliable vehicle operation. You are not required to perform maintenance on these items in order to maintain the warranties which come with your vehicle. Other maintenance items and intervals are required.

When applicable, additional information can be found in the "8. Do-it-yourself" section of this manual.

NOTE:

NISSAN does not advocate the use of non-OEM approved aftermarket flushing systems and strongly advises against performing these services on a NISSAN product. Many of the aftermarket flushing systems use non-OEM approved chemicals or solvents, the use of which has not been validated by NISSAN.

For recommended fuel, lubricants, fluids, grease, and refrigerant, refer to "Capacities and recommended fluids/lubricants" (P.10-3) of this manual.

EMISSION CONTROL SYSTEM MAINTENANCE

Drive belt*:

Check engine drive belt for wear, fraying or cracking and for proper tension. Replace any damaged drive belt.

Engine air filter:

Replace at specified intervals. When driving for prolonged periods in dusty conditions, check/replace the filter more frequently.

Engine coolant*:

Replace coolant at the specified interval. When adding or replacing coolant, be sure to use only Genuine NISSAN Long Life Antifreeze/Coolant (blue) or equivalent with the proper mixture. (Refer to "Engine cooling system" (P.8-4) to determine the proper mixture for your area.)

NOTE:

Mixing any other type of coolant or the use of non-distilled water may reduce the recommended service interval of the coolant.

Intercooler coolant:

Intercooler coolant is maintenance-free.

Engine oil and oil filter:

Replace engine oil and oil filter at the specified intervals. For recommended oil grade and viscosity refer to "Capacities and recommended fluids/lubricants" (P.10-3).

Engine valve clearance*:

Inspect only if valve noise increases.

Adjust valve clearance if necessary.

Evaporative emissions control vapor lines*:

Check vapor lines for leaks or looseness. Tighten connections or replace parts as necessary.

Fuel filter

Periodic maintenance is not required (in-tank type filter).

Fuel lines*:

Check the fuel hoses, piping and connections for leaks, looseness, or deterioration. Tighten connections or replace parts as necessary.

Spark plugs:

Replace at specified intervals. Install new plugs of the type as originally equipped.

CHASSIS AND BODY MAINTENANCE

Brake lines:

Visually inspect for proper installation. Check for chafing, cracks, deterioration, and signs of leaking. Replace any deteriorated or damaged parts immediately.

Brake pads and rotors:

Check for wear, deterioration and fluid leaks. Replace any deteriorated or damaged parts immediately.

Exhaust system:

Visually inspect the exhaust pipes, muffler and hangers for leaks, cracks, deterioration, and damage. Tighten connections or replace parts as necessary.

In-cabin microfilter:

Replace at specified intervals. When driving for prolonged periods in dusty conditions, replace the filter more frequently.

Propeller shaft(s):

Check for damage, looseness, and grease leakage. (AWD)

Steering gear and linkage, axle and suspension parts, drive shaft boots:

Check for damage, looseness, and leakage of oil or grease. Under severe driving conditions, inspect more frequently.

Tire rotation:

Rotate tires at the specified interval.

Transmission fluid/oil, differential oil, coupling oil and transfer case oil:

Visually inspect for signs of leakage at specified intervals.

If using a car-top carrier, or towing a trailer, or using a camper, or driving on rough or muddy roads:

- Replace the differential oil and transfer case oil every 20,000 miles (32,000 km) or 24 months.
- Replace the CVT fluid every 60,000 miles (96,000 km) or request the dealer to inspect the fluid deterioration data using a CONSULT. If the deterioration data is more than 210,000, replace the CVT fluid.

MAINTENANCE SCHEDULES

To help ensure smooth, safe and economical driving, NISSAN provides two maintenance schedules that may be used, depending upon the conditions in which you usually drive. These schedules contain both distance and time intervals, up to 120,000 miles (192,000 km)/96 months. For most people, the odometer reading will indicate when service is needed. However, if you drive very little, your vehicle should be serviced at the regular time intervals shown in the schedule.

After 120,000 miles (192,000 km)/96 months, continue maintenance at the same mileage/time intervals.

ADDITIONAL MAINTENANCE ITEMS FOR SEVERE OPERATING CONDITIONS

Additional maintenance items for severe operating conditions; should be performed on vehicles that are driven under especially demanding conditions. Additional maintenance items should be performed if you primarily operate your vehicle under the following conditions:

- Repeated short trips of less than 5 miles (8 km).
- Repeated short trips of less than 10 miles (16 km) with outside temperatures remaining below freezing.

- Operating in hot weather in stop-and-go "rush hour" traffic.
- Extensive idling and/or low speed driving for long distances, such as police, taxi or door-to-door delivery use.
- Driving in dusty conditions.
- Driving on rough, muddy or salt spread roads.
- Using a car-top carrier.
- Towing a trailer.
- Using a camper.

If your vehicle is mainly operated under the severe conditions, follow the severe maintenance intervals shown in the maintenance schedule.

OIL CONTROL SYSTEM

Your vehicle is equipped with oil control system. It calculates engine oil and filter change intervals based on driving conditions. Driving in the following severe conditions will shorten the engine oil and filter change interval.

STANDARD MAINTENANCE

PR25DD ENGINE MODEL

The following shows the maintenance schedule. Choose the maintenance schedule needed based on your vehicle driving conditions.

After 120,000 miles (192,000 km)/144 months, continue maintenance at the same mileage/time interval.

5,000 Miles/6 Months/8,000 Km

Standard maintenance:

- Perform tire rotation

Severe maintenance:

- Inspect brake pads and rotors
- Inspect exhaust system
- Inspect steering gear and linkage
- Inspect axle and suspension parts
- Inspect propeller shaft (AWD models)
- Inspect drive shaft boots

10,000 Miles/12 Months/16,000 Km

Standard maintenance:

- Inspect brake lines
- Inspect brake pads and rotors
- Inspect CVT fluid
- Inspect propeller shaft (AWD models)
- Inspect differential gear oil (AWD models)
- Inspect AWD coupling oil (AWD models)
- Inspect transfer case oil (AWD models)
- Inspect drive shaft boots
- Replace engine oil and filter (1)
- Perform tire rotation

Severe maintenance:

- Inspect brake pads and rotors
- Inspect exhaust system
- Inspect steering gear and linkage
- Inspect axle and suspension parts
- Inspect propeller shaft (AWD models)
- Inspect drive shaft boots
- Replace brake fluid

(1) If the oil replacement indicator is displayed, change the engine oil and filter within two weeks or less than 500 miles (800 km).

15,000 Miles/18 Months/24,000

Km

Standard maintenance:

- Inspect Intelligent Key battery
- Replace In-cabin microfilter
- Perform tire rotation

Severe maintenance:

- Inspect brake pads and rotors
- Inspect exhaust system
- Inspect steering gear and linkage
- Inspect axle and suspension parts
- Inspect propeller shaft (AWD models)
- Inspect drive shaft boots

20,000 Miles/24 Months/32,000

Km

Standard maintenance:

- Inspect brake lines
- Inspect brake pads and rotors
- Inspect CVT fluid
- Inspect fuel tank vapor vent system
- Inspect fuel lines/connections
- Inspect exhaust system
- Inspect steering gear and linkage
- Inspect axle and suspension parts
- Inspect propeller shaft (AWD models)
- Inspect differential gear oil (AWD models)
- Inspect AWD coupling oil (AWD models)
- Inspect transfer case oil (AWD models)
- Inspect drive shaft boots
- Replace brake fluid
- Replace engine oil and filter (1)
- Perform tire rotation

Severe maintenance:

- Inspect brake pads and rotors
- Inspect exhaust system
- Inspect steering gear and linkage
- Inspect axle and suspension parts
- Inspect propeller shaft (AWD models)
- Inspect drive shaft boots
- Replace brake fluid

(1) If the oil replacement indicator is displayed, change the engine oil and filter within two weeks or less than 500 miles (800 km).

25,000 Miles/30 Months/40,000

Km

Standard maintenance:

- Perform tire rotation

Severe maintenance:

- Inspect brake pads and rotors
- Inspect exhaust system
- Inspect steering gear and linkage
- Inspect axle and suspension parts
- Inspect propeller shaft (AWD models)
- Inspect drive shaft boots

30,000 Miles/36 Months/48,000

Km

Standard maintenance:

- Inspect brake lines
- Inspect brake pads and rotors
- Inspect CVT fluid
- Inspect propeller shaft (AWD models)
- Inspect differential gear oil (AWD models)
- Inspect AWD coupling oil (AWD models)
- Inspect transfer case oil (AWD models)
- Inspect drive shaft boots
- Replace engine air filter (1)
- Replace engine oil and filter (2)
- Replace In-cabin microfilter
- Replace Intelligent Key battery
- Perform tire rotation

Severe maintenance:

- Inspect brake pads and rotors
- Inspect exhaust system
- Inspect steering gear and linkage
- Inspect axle and suspension parts
- Inspect propeller shaft (AWD models)
- Inspect drive shaft boots
- Replace brake fluid

(1) If operating mainly in dusty conditions, more frequent maintenance may be required.

(2) If the oil replacement indicator is displayed, change the engine oil and filter within two weeks or less than 500 miles (800 km).

35,000 Miles/42 Months/56,000

Km

Standard maintenance:

- Perform tire rotation

Severe maintenance:

- Inspect brake pads and rotors
- Inspect exhaust system
- Inspect steering gear and linkage
- Inspect axle and suspension parts
- Inspect propeller shaft (AWD models)
- Inspect drive shaft boots

40,000 Miles/48 Months/64,000

Km

Standard maintenance:

- Inspect brake lines
- Inspect brake pads and rotors
- Inspect CVT fluid
- Inspect engine drive belts
- Inspect fuel tank vapor vent system
- Inspect fuel lines/connections
- Inspect exhaust system
- Inspect steering gear and linkage
- Inspect axle and suspension part
- Inspect propeller shaft (AWD models)
- Inspect differential gear oil (AWD models)
- Inspect AWD coupling oil (AWD models)
- Inspect transfer case oil (AWD models)
- Inspect drive shaft boots
- Replace brake fluid
- Replace engine oil and filter (1)
- Perform tire rotation

Severe maintenance:

- Inspect brake pads and rotors
- Inspect exhaust system
- Inspect steering gear and linkage
- Inspect axle and suspension parts
- Inspect propeller shaft (AWD models)
- Inspect drive shaft boots
- Replace brake fluid

(1) If the oil replacement indicator is displayed, change the engine oil and filter within two weeks or less than 500 miles (800 km).

45,000 Miles/54 Months/72,000

Km

Standard maintenance:

- Replace In-cabin microfilter
- Replace Intelligent Key battery
- Perform tire rotation

Severe maintenance:

- Inspect brake pads and rotors
- Inspect exhaust system
- Inspect steering gear and linkage
- Inspect axle and suspension parts
- Inspect propeller shaft (AWD models)
- Inspect drive shaft boots

50,000 Miles/60 Months/80,000

Km

Standard maintenance:

- Inspect brake lines
- Inspect brake pads and rotors
- Inspect CVT fluid
- Inspect engine drive belts
- Inspect propeller shaft (AWD models)
- Inspect differential gear oil (AWD models)
- Inspect AWD coupling oil (AWD models)
- Inspect transfer case oil (AWD models)
- Inspect drive shaft boots
- Replace engine oil and filter (1)
- Perform tire rotation

Severe maintenance:

- Inspect brake pads and rotors
- Inspect exhaust system
- Inspect steering gear and linkage
- Inspect axle and suspension parts
- Inspect propeller shaft (AWD models)
- Inspect drive shaft boots
- Replace brake fluid

(1) If the oil replacement indicator is displayed, change the engine oil and filter within two weeks or less than 500 miles (800 km).

55,000 Miles/66 Months/88,000

Km

Standard maintenance:

- Perform tire rotation

Severe maintenance:

- Inspect brake pads and rotors
- Inspect exhaust system
- Inspect steering gear and linkage
- Inspect axle and suspension parts
- Inspect propeller shaft (AWD models)
- Inspect drive shaft boots

60,000 Miles/72 Months/96,000

Km

Standard maintenance:

- Inspect brake lines
- Inspect brake pads and rotors
- Inspect CVT fluid
- Inspect engine drive belts
- Inspect fuel tank vapor vent system
- Inspect fuel lines/connections
- Inspect exhaust system
- Inspect steering gear and linkage
- Inspect axle and suspension part
- Inspect propeller shaft (AWD models)
- Inspect differential gear oil (AWD models)
- Inspect AWD coupling oil (AWD models)
- Inspect transfer case oil (AWD models)
- Inspect drive shaft boots
- Replace engine air filter (1)
- Replace brake fluid
- Replace engine oil and filter (2)
- Replace In-cabin microfilter
- Replace Intelligent Key battery
- Perform tire rotation

Severe maintenance:

- Inspect brake pads and rotors
- Inspect exhaust system
- Inspect steering gear and linkage
- Inspect axle and suspension parts
- Inspect propeller shaft (AWD models)
- Inspect drive shaft boots
- Replace brake fluid
- Replace CVT fluid

(1) If operating mainly in dusty conditions, more frequent maintenance may be required.
(2) If the oil replacement indicator is displayed, change the engine oil and filter within two weeks or less than 500 miles (800 km).

65,000 Miles/78 Months/104,000

Km

Standard maintenance:

- Perform tire rotation

Severe maintenance:

- Inspect brake pads and rotors
- Inspect exhaust system
- Inspect steering gear and linkage
- Inspect axle and suspension parts
- Inspect propeller shaft (AWD models)
- Inspect drive shaft boots

70,000 Miles/84 Months/112,000

Km

Standard maintenance:

- Inspect brake lines
- Inspect brake pads and rotors
- Inspect CVT fluid
- Inspect engine drive belts
- Inspect propeller shaft (AWD models)
- Inspect differential gear oil (AWD models)
- Inspect AWD coupling oil (AWD models)
- Inspect transfer case oil (AWD models)
- Inspect drive shaft boots
- Replace engine oil and filter (1)
- Perform tire rotation

Severe maintenance:

- Inspect brake pads and rotors
- Inspect exhaust system
- Inspect steering gear and linkage
- Inspect axle and suspension parts
- Inspect propeller shaft (AWD models)
- Inspect drive shaft boots
- Replace brake fluid

(1) If the oil replacement indicator is displayed, change the engine oil and filter within two weeks or less than 500 miles (800 km).

75,000 Miles/90 Months/120,000

Km

Standard maintenance:

- Replace In-cabin microfilter
- Replace Intelligent Key battery
- Perform tire rotation

Severe maintenance:

- Inspect brake pads and rotors
- Inspect exhaust system
- Inspect steering gear and linkage
- Inspect axle and suspension parts
- Inspect propeller shaft (AWD models)
- Inspect drive shaft boots

80,000 Miles/96 Months/128,000

Km

Standard maintenance:

- Inspect brake lines
- Inspect brake pads and rotors
- Inspect CVT fluid
- Inspect engine drive belts
- Inspect fuel tank vapor vent system
- Inspect fuel lines/connections
- Inspect exhaust system
- Inspect steering gear and linkage
- Inspect axle and suspension part
- Inspect propeller shaft (AWD models)
- Inspect differential gear oil (AWD models)
- Inspect AWD coupling oil (AWD models)
- Inspect transfer case oil (AWD models)
- Inspect drive shaft boots
- Replace brake fluid
- Replace engine oil and filter (1)
- Perform tire rotation

Severe maintenance:

- Inspect brake pads and rotors
- Inspect exhaust system
- Inspect steering gear and linkage
- Inspect axle and suspension parts
- Inspect propeller shaft (AWD models)
- Inspect drive shaft boots
- Replace brake fluid

(1) If the oil replacement indicator is displayed, change the engine oil and filter within two weeks or less than 500 miles (800 km).

85,000 Miles/102 Months/136,000

Km

Standard maintenance:

- Perform tire rotation

Severe maintenance:

- Inspect brake pads and rotors
- Inspect exhaust system
- Inspect steering gear and linkage
- Inspect axle and suspension parts
- Inspect propeller shaft (AWD models)
- Inspect drive shaft boots

90,000 Miles/108 Months/144,000

Km

Standard maintenance:

- Inspect brake lines
- Inspect brake pads and rotors
- Inspect CVT fluid
- Inspect engine drive belts
- Inspect propeller shaft (AWD models)
- Inspect differential gear oil (AWD models)
- Inspect AWD coupling oil (AWD models)
- Inspect transfer case oil (AWD models)
- Inspect drive shaft boots
- Replace engine air filter (1)
- Replace engine oil and filter (2)
- Replace In-cabin microfilter
- Replace Intelligent Key battery
- Perform tire rotation

Severe maintenance:

- Inspect brake pads and rotors
- Inspect exhaust system
- Inspect steering gear and linkage
- Inspect axle and suspension parts
- Inspect propeller shaft (AWD models)
- Inspect drive shaft boots
- Replace brake fluid

(1) If operating mainly in dusty conditions, more frequent maintenance may be required.

(2) If the oil replacement indicator is displayed, change the engine oil and filter within two weeks or less than 500 miles (800 km).

95,000 Miles/114 Months/152,000

Km

Standard maintenance:

- Perform tire rotation

Severe maintenance:

- Inspect brake pads and rotors
- Inspect exhaust system
- Inspect steering gear and linkage
- Inspect axle and suspension parts
- Inspect propeller shaft (AWD models)
- Inspect drive shaft boots

100,000 Miles/120 Months/160,000

Km

Standard maintenance:

- Inspect brake lines
- Inspect brake pads and rotors
- Inspect CVT fluid
- Inspect engine drive belts
- Inspect fuel tank vapor vent system
- Inspect fuel lines/connections
- Inspect exhaust system
- Inspect steering gear and linkage
- Inspect axle and suspension part
- Inspect propeller shaft (AWD models)
- Inspect differential gear oil (AWD models)
- Inspect AWD coupling oil (AWD models)
- Inspect transfer case oil (AWD models)
- Inspect drive shaft boots
- Replace brake fluid
- Replace engine oil and filter (1)
- Perform tire rotation

Severe maintenance:

- Inspect brake pads and rotors
- Inspect exhaust system
- Inspect steering gear and linkage
- Inspect axle and suspension parts
- Inspect propeller shaft (AWD models)
- Inspect drive shaft boots
- Replace brake fluid

(1) If the oil replacement indicator is displayed, change the engine oil and filter within two weeks or less than 500 miles (800 km).

105,000 Miles/126 Months/168,000
Km

Standard maintenance:

- Replace In-cabin microfilter
- Replace Intelligent Key battery
- Perform tire rotation
- Replace spark plugs (1) (2)
- Replace engine coolant* (3)

Severe maintenance:

- Inspect brake pads and rotors
- Inspect exhaust system
- Inspect steering gear and linkage
- Inspect axle and suspension parts
- Inspect propeller shaft (AWD models)
- Inspect drive shaft boots

(1) Performed based on the number of miles only

(2) Replace spark plug when the plug gap exceeds 0.053 in (1.35 mm) even if within specified periodic replacement mileage.

(3) First replacement interval is 105,000 miles (168,000 km) or 84 months. After first replacement, replace every 75,000 miles (120,000 km) or 60 months.

*: Maintenance items and intervals with " * " are recommended by NISSAN for reliable vehicle operation. The owner need not perform such maintenance in order to maintain the emission warranty or manufacturer recall liability. Other maintenance items and intervals are required.

110,000 Miles/132 Months/176,000
Km

Standard maintenance:

- Inspect brake lines
- Inspect brake pads and rotors
- Inspect CVT fluid
- Inspect engine drive belts
- Inspect propeller shaft (AWD models)
- Inspect differential gear oil (AWD models)
- Inspect AWD coupling oil (AWD models)
- Inspect transfer case oil (AWD models)
- Inspect drive shaft boots
- Replace engine oil and filter (1)
- Perform tire rotation

Severe maintenance:

- Inspect brake pads and rotors
- Inspect exhaust system
- Inspect steering gear and linkage
- Inspect axle and suspension parts
- Inspect propeller shaft (AWD models)
- Inspect drive shaft boots
- Replace brake fluid

(1) If the oil replacement indicator is displayed, change the engine oil and filter within two weeks or less than 500 miles (800 km).

115,000 Miles/138 Months/184,000
Km

Standard maintenance:

- Perform tire rotation

Severe maintenance:

- Inspect brake pads and rotors
- Inspect exhaust system
- Inspect steering gear and linkage
- Inspect axle and suspension parts
- Inspect propeller shaft (AWD models)
- Inspect drive shaft boots

120,000 Miles/144 Months/192,000
Km

Standard maintenance:

- Inspect brake lines
- Inspect brake pads and rotors
- Inspect CVT fluid
- Inspect engine drive belts
- Inspect fuel tank vapor vent system
- Inspect fuel lines/connections
- Inspect exhaust system
- Inspect steering gear and linkage
- Inspect axle and suspension part
- Inspect propeller shaft (AWD models)
- Inspect differential gear oil (AWD models)
- Inspect AWD coupling oil (AWD models)
- Inspect transfer case oil (AWD models)
- Inspect drive shaft boots
- Replace engine air filter (1)
- Replace brake fluid
- Replace engine oil and filter (2)
- Replace In-cabin microfilter
- Replace Intelligent Key battery
- Perform tire rotation

Severe maintenance:

- Inspect brake pads and rotors
- Inspect exhaust system
- Inspect steering gear and linkage
- Inspect axle and suspension parts
- Inspect propeller shaft (AWD models)
- Inspect drive shaft boots
- Replace brake fluid
- Replace CVT fluid

(1) If operating mainly in dusty conditions, more frequent maintenance may be required.

(2) If the oil replacement indicator is displayed, change the engine oil and filter within two weeks or less than 500 miles (800 km).

KR15DDT ENGINE MODEL

The following shows the maintenance schedule. Choose the maintenance schedule needed based on your vehicle driving conditions.

After 90,000 miles (144,000 km)/144 months, continue maintenance at the same mileage/time interval.

3,750 Miles/6 Months/6,000 Km

Standard maintenance:

- Perform tire rotation

Severe maintenance:

- Inspect brake pads and rotors
- Inspect exhaust system
- Inspect steering gear and linkage
- Inspect axle and suspension parts
- Inspect propeller shaft (AWD models)
- Inspect drive shaft boots

7,500 Miles/12 Months/12,000 Km

Standard maintenance:

- Inspect brake lines
- Inspect brake pads and rotors
- Inspect CVT fluid
- Inspect propeller shaft (AWD models)
- Inspect differential gear oil (AWD models)
- Inspect AWD coupling oil (AWD models)
- Inspect transfer case oil (AWD models)
- Inspect drive shaft boots
- Replace engine oil and filter (1)
- Perform tire rotation

Severe maintenance:

- Inspect brake pads and rotors
- Inspect exhaust system
- Inspect steering gear and linkage
- Inspect axle and suspension parts
- Inspect propeller shaft (AWD models)
- Inspect drive shaft boots
- Replace brake fluid

(1) If the oil replacement indicator is displayed, change the engine oil and filter within two weeks or less than 500 miles (800 km).

11,250 Miles/18 Months/18,000 Km

Standard maintenance:

- Inspect Intelligent Key battery
- Replace In-cabin microfilter
- Perform tire rotation

Severe maintenance:

- Inspect brake pads and rotors
- Inspect exhaust system
- Inspect steering gear and linkage
- Inspect axle and suspension parts
- Inspect propeller shaft (AWD models)
- Inspect drive shaft boots

15,000 Miles/24 Months/24,000

Km

Standard maintenance:

- Inspect brake lines
- Inspect brake pads and rotors
- Inspect CVT fluid
- Inspect fuel tank vapor vent system
- Inspect fuel lines/connections
- Inspect exhaust system
- Inspect steering gear and linkage
- Inspect axle and suspension parts
- Inspect propeller shaft (AWD models)
- Inspect differential gear oil (AWD models)
- Inspect AWD coupling oil (AWD models)
- Inspect transfer case oil (AWD models)
- Inspect drive shaft boots
- Replace brake fluid
- Replace engine oil and filter (1)
- Perform tire rotation

Severe maintenance:

- Inspect brake pads and rotors
- Inspect exhaust system
- Inspect steering gear and linkage
- Inspect axle and suspension parts
- Inspect propeller shaft (AWD models)
- Inspect drive shaft boots
- Replace brake fluid

(1) If the oil replacement indicator is displayed, change the engine oil and filter within two weeks or less than 500 miles (800 km).

18,750 Miles/30 Months/30,000

Km

Standard maintenance:

- Perform tire rotation

Severe maintenance:

- Inspect brake pads and rotors
- Inspect exhaust system
- Inspect steering gear and linkage
- Inspect axle and suspension parts
- Inspect propeller shaft (AWD models)
- Inspect drive shaft boots

22,500 Miles/36 Months/36,000

Km

Standard maintenance:

- Inspect brake lines
- Inspect brake pads and rotors
- Inspect CVT fluid
- Inspect propeller shaft (AWD models)
- Inspect differential gear oil (AWD models)
- Inspect AWD coupling oil (AWD models)
- Inspect transfer case oil (AWD models)
- Inspect drive shaft boots
- Replace engine oil and filter (1)
- Replace In-cabin microfilter
- Replace Intelligent Key battery
- Perform tire rotation

Severe maintenance:

- Inspect brake pads and rotors
- Inspect exhaust system
- Inspect steering gear and linkage
- Inspect axle and suspension parts
- Inspect propeller shaft (AWD models)
- Inspect drive shaft boots
- Replace brake fluid

(1) If the oil replacement indicator is displayed, change the engine oil and filter within two weeks or less than 500 miles (800 km).

26,250 Miles/42 Months/42,000

Km

Standard maintenance:

- Perform tire rotation

Severe maintenance:

- Inspect brake pads and rotors
- Inspect exhaust system
- Inspect steering gear and linkage
- Inspect axle and suspension parts
- Inspect propeller shaft (AWD models)
- Inspect drive shaft boots

30,000 Miles/48 Months/48,000

Km

Standard maintenance:

- Inspect brake lines
- Inspect brake pads and rotors
- Inspect CVT fluid
- Inspect engine drive belts
- Inspect fuel tank vapor vent system
- Inspect fuel lines/connections
- Inspect exhaust system
- Inspect steering gear and linkage
- Inspect axle and suspension part
- Inspect propeller shaft (AWD models)
- Inspect differential gear oil (AWD models)
- Inspect AWD coupling oil (AWD models)
- Inspect transfer case oil (AWD models)
- Inspect drive shaft boots
- Replace engine air filter (1)
- Replace brake fluid
- Replace engine oil and filter (2)
- Perform tire rotation

Severe maintenance:

- Inspect brake pads and rotors
- Inspect exhaust system
- Inspect steering gear and linkage
- Inspect axle and suspension parts
- Inspect propeller shaft (AWD models)
- Inspect drive shaft boots
- Replace brake fluid

(1) If operating mainly in dusty conditions, more frequent maintenance may be required.

(2) If the oil replacement indicator is displayed, change the engine oil and filter within two weeks or less than 500 miles (800 km).

33,750 Miles/54 Months/54,000

Km

Standard maintenance:

- Replace In-cabin microfilter
- Replace Intelligent Key battery
- Perform tire rotation

Severe maintenance:

- Inspect brake pads and rotors
- Inspect exhaust system
- Inspect steering gear and linkage
- Inspect axle and suspension parts
- Inspect propeller shaft (AWD models)
- Inspect drive shaft boots

37,500 Miles/60 Months/60,000

Km

Standard maintenance:

- Inspect brake lines
- Inspect brake pads and rotors
- Inspect CVT fluid
- Inspect engine drive belts
- Inspect propeller shaft (AWD models)
- Inspect differential gear oil (AWD models)
- Inspect AWD coupling oil (AWD models)
- Inspect transfer case oil (AWD models)
- Inspect drive shaft boots
- Replace engine oil and filter (1)
- Perform tire rotation

Severe maintenance:

- Inspect brake pads and rotors
- Inspect exhaust system
- Inspect steering gear and linkage
- Inspect axle and suspension parts
- Inspect propeller shaft (AWD models)
- Inspect drive shaft boots
- Replace brake fluid

(1) If the oil replacement indicator is displayed, change the engine oil and filter within two weeks or less than 500 miles (800 km).

41,250 Miles/66 Months/66,000

Km

Standard maintenance:

- Perform tire rotation

Severe maintenance:

- Inspect brake pads and rotors
- Inspect exhaust system
- Inspect steering gear and linkage
- Inspect axle and suspension parts
- Inspect propeller shaft (AWD models)
- Inspect drive shaft boots

45,000 Miles/72 Months/72,000

Km

Standard maintenance:

- Inspect brake lines
- Inspect brake pads and rotors
- Inspect CVT fluid
- Inspect engine drive belts
- Inspect fuel tank vapor vent system
- Inspect fuel lines/connections
- Inspect exhaust system
- Inspect steering gear and linkage
- Inspect axle and suspension part
- Inspect propeller shaft (AWD models)
- Inspect differential gear oil (AWD models)
- Inspect AWD coupling oil (AWD models)
- Inspect transfer case oil (AWD models)
- Inspect drive shaft boots
- Replace brake fluid
- Replace engine oil and filter (1)
- Replace In-cabin microfilter
- Replace Intelligent Key battery
- Perform tire rotation

Severe maintenance:

- Inspect brake pads and rotors
- Inspect exhaust system
- Inspect steering gear and linkage
- Inspect axle and suspension parts
- Inspect propeller shaft (AWD models)
- Inspect drive shaft boots
- Replace brake fluid

(1) If the oil replacement indicator is displayed, change the engine oil and filter within two weeks or less than 500 miles (800 km).

48,750 Miles/78 Months/78,000

Km

Standard maintenance:

- Perform tire rotation

Severe maintenance:

- Inspect brake pads and rotors
- Inspect exhaust system
- Inspect steering gear and linkage
- Inspect axle and suspension parts
- Inspect propeller shaft (AWD models)
- Inspect drive shaft boots

52,500 Miles/84 Months/84,000

Km

Standard maintenance:

- Inspect brake lines
- Inspect brake pads and rotors
- Inspect CVT fluid
- Inspect engine drive belts
- Inspect propeller shaft (AWD models)
- Inspect differential gear oil (AWD models)
- Inspect AWD coupling oil (AWD models)
- Inspect transfer case oil (AWD models)
- Inspect drive shaft boots
- Replace engine oil and filter (1)
- Perform tire rotation

Severe maintenance:

- Inspect brake pads and rotors
- Inspect exhaust system
- Inspect steering gear and linkage
- Inspect axle and suspension parts
- Inspect propeller shaft (AWD models)
- Inspect drive shaft boots
- Replace brake fluid

(1) If the oil replacement indicator is displayed, change the engine oil and filter within two weeks or less than 500 miles (800 km).

56,250 Miles/90 Months/90,000

Km

Standard maintenance:

- Replace In-cabin microfilter
- Replace Intelligent Key battery
- Perform tire rotation

Severe maintenance:

- Inspect brake pads and rotors
- Inspect exhaust system
- Inspect steering gear and linkage
- Inspect axle and suspension parts
- Inspect propeller shaft (AWD models)
- Inspect drive shaft boots

60,000 Miles/96 Months/96,000

Km

Standard maintenance:

- Inspect brake lines
- Inspect brake pads and rotors
- Inspect CVT fluid
- Inspect engine drive belts
- Inspect fuel tank vapor vent system
- Inspect fuel lines/connections
- Inspect exhaust system
- Inspect steering gear and linkage
- Inspect axle and suspension part
- Inspect propeller shaft (AWD models)
- Inspect differential gear oil (AWD models)
- Inspect AWD coupling oil (AWD models)
- Inspect transfer case oil (AWD models)
- Inspect drive shaft boots
- Replace engine air filter (1)
- Replace brake fluid
- Replace engine oil and filter (2)
- Perform tire rotation

Severe maintenance:

- Inspect brake pads and rotors
- Inspect exhaust system
- Inspect steering gear and linkage
- Inspect axle and suspension parts
- Inspect propeller shaft (AWD models)
- Inspect drive shaft boots
- Replace brake fluid

(1) If operating mainly in dusty conditions, more frequent maintenance may be required.

(2) If the oil replacement indicator is displayed, change the engine oil and filter within two weeks or less than 500 miles (800 km).

63,750 Miles/102 Months/102,000

Km

Standard maintenance:

- Perform tire rotation

Severe maintenance:

- Inspect brake pads and rotors
- Inspect exhaust system
- Inspect steering gear and linkage
- Inspect axle and suspension parts
- Inspect propeller shaft (AWD models)
- Inspect drive shaft boots

67,500 Miles/108 Months/108,000

Km

Standard maintenance:

- Inspect brake lines
- Inspect brake pads and rotors
- Inspect CVT fluid
- Inspect engine drive belts
- Inspect propeller shaft (AWD models)
- Inspect differential gear oil (AWD models)
- Inspect AWD coupling oil (AWD models)
- Inspect transfer case oil (AWD models)
- Inspect drive shaft boots
- Replace engine oil and filter (1)
- Replace In-cabin microfilter
- Replace Intelligent Key battery
- Perform tire rotation

Severe maintenance:

- Inspect brake pads and rotors
- Inspect exhaust system
- Inspect steering gear and linkage
- Inspect axle and suspension parts
- Inspect propeller shaft (AWD models)
- Inspect drive shaft boots
- Replace brake fluid

(1) If the oil replacement indicator is displayed, change the engine oil and filter within two weeks or less than 500 miles (800 km).

71,250 Miles/114 Months/114,000

Km

Standard maintenance:

- Perform tire rotation

Severe maintenance:

- Inspect brake pads and rotors
- Inspect exhaust system
- Inspect steering gear and linkage
- Inspect axle and suspension parts
- Inspect propeller shaft (AWD models)
- Inspect drive shaft boots

75,000 Miles/120 Months/120,000

Km

Standard maintenance:

- Inspect brake lines
- Inspect brake pads and rotors
- Inspect CVT fluid
- Inspect engine drive belts
- Inspect fuel tank vapor vent system
- Inspect fuel lines/connections
- Inspect exhaust system
- Inspect steering gear and linkage
- Inspect axle and suspension part
- Inspect propeller shaft (AWD models)
- Inspect differential gear oil (AWD models)
- Inspect AWD coupling oil (AWD models)
- Inspect transfer case oil (AWD models)
- Inspect drive shaft boots
- Replace brake fluid
- Replace engine oil and filter (1)
- Perform tire rotation

Severe maintenance:

- Inspect brake pads and rotors
- Inspect exhaust system
- Inspect steering gear and linkage
- Inspect axle and suspension parts
- Inspect propeller shaft (AWD models)
- Inspect drive shaft boots
- Replace brake fluid

(1) If the oil replacement indicator is displayed, change the engine oil and filter within two weeks or less than 500 miles (800 km).

78,750 Miles/126 Months/126,000

Km

Standard maintenance:

- Replace In-cabin microfilter
- Replace Intelligent Key battery
- Perform tire rotation

Severe maintenance:

- Inspect brake pads and rotors
- Inspect exhaust system
- Inspect steering gear and linkage
- Inspect axle and suspension parts
- Inspect propeller shaft (AWD models)
- Inspect drive shaft boots

82,500 Miles/132 Months/132,000

Km

Standard maintenance:

- Inspect brake lines
- Inspect brake pads and rotors
- Inspect CVT fluid
- Inspect engine drive belts
- Inspect propeller shaft (AWD models)
- Inspect differential gear oil (AWD models)
- Inspect AWD coupling oil (AWD models)
- Inspect transfer case oil (AWD models)
- Inspect drive shaft boots
- Replace engine oil and filter (1)
- Perform tire rotation

Severe maintenance:

- Inspect brake pads and rotors
- Inspect exhaust system
- Inspect steering gear and linkage
- Inspect axle and suspension parts
- Inspect propeller shaft (AWD models)
- Inspect drive shaft boots
- Replace brake fluid

(1) If the oil replacement indicator is displayed, change the engine oil and filter within two weeks or less than 500 miles (800 km).

86,250 Miles/138 Months/138,000

Km

Standard maintenance:

- Perform tire rotation

Severe maintenance:

- Inspect brake pads and rotors
- Inspect exhaust system
- Inspect steering gear and linkage
- Inspect axle and suspension parts
- Inspect propeller shaft (AWD models)
- Inspect drive shaft boots

90,000 Miles/144 Months/144,000

Km

Standard maintenance:

- Inspect brake lines
- Inspect brake pads and rotors
- Inspect CVT fluid
- Inspect engine drive belts
- Inspect fuel tank vapor vent system
- Inspect fuel lines/connections
- Inspect exhaust system
- Inspect steering gear and linkage
- Inspect axle and suspension part
- Inspect propeller shaft (AWD models)
- Inspect differential gear oil (AWD models)
- Inspect AWD coupling oil (AWD models)
- Inspect transfer case oil (AWD models)
- Inspect drive shaft boots
- Replace engine air filter (1)
- Replace brake fluid
- Replace engine oil and filter (2)
- Replace In-cabin microfilter
- Replace Intelligent Key battery
- Perform tire rotation

Severe maintenance:

- Inspect brake pads and rotors
- Inspect exhaust system
- Inspect steering gear and linkage
- Inspect axle and suspension parts
- Inspect propeller shaft (AWD models)
- Inspect drive shaft boots
- Replace brake fluid

(1) If operating mainly in dusty conditions, more frequent maintenance may be required.

(2) If the oil replacement indicator is displayed, change the engine oil and filter within two weeks or less than 500 miles (800 km).

Additional information

NOTE FOR ENGINE COOLANT *:

(1) First replacement interval is 105,000 miles (168,000 km) or 84 months. After first replacement, replace every 75,000 miles (120,000 km) or 60 months.

(2) Use only Genuine NISSAN Long Life Antifreeze/Coolant (blue) or equivalent with proper mixture ratio of 50% antifreeze and 50% demineralized or distilled water. Mixing any other type of coolant or the use of non-distilled water may reduce the life expectancy of the factory fill coolant.

* Maintenance items and intervals with " * " are recommended by NISSAN for reliable vehicle operation. The owner need not perform such maintenance in order to maintain the emission warranty or manufacturer recall liability. Other maintenance items and intervals are required.

NOTE FOR SPARK PLUGS:

(1) Replace every 105,000 miles (168,000 km)
(2) Replace spark plug when the plug gap exceeds 0.041 in (1.05 mm) even if within specified replacement mileage.

10 Technical and consumer information

Capacities and recommended fluids/lubricants	10-3	Securing the load	10-17
Fuel information	10-5	Loading tips	10-17
Engine oil and oil filter recommendation	10-7	Measurement of weights	10-18
Air conditioning system refrigerant and lubricant recommendations	10-8	Towing a trailer	10-18
Specifications	10-9	Maximum load limits	10-19
Engine	10-9	Maximum Gross Vehicle Weight (GVW)/ maximum Gross Axle Weight (GAW)	10-20
Wheels and tires	10-10	Towing load/specification	10-22
Dimensions and weights	10-10	Towing safety	10-23
When traveling or registering in another country	10-10	Flat towing	10-28
Vehicle identification	10-11	Flat towing for All-Wheel Drive vehicle (if so equipped)	10-28
Vehicle Identification Number (VIN) plate	10-11	Flat towing for Front-Wheel Drive vehicle (if so equipped)	10-28
Vehicle identification number (chassis number)	10-11	Uniform tire quality grading	10-29
Engine serial number	10-12	Treadwear	10-29
F.M.V.S.S./C.M.V.S.S. certification label	10-12	Traction AA, A, B and C	10-29
Emission control information label	10-12	Temperature A, B and C	10-29
Tire and Loading Information label	10-13	Emission control system warranty	10-30
Air conditioner specification label	10-13	Reporting safety defects	10-30
Installing front license plate	10-14	Readiness for Inspection/Maintenance (I/M) test	10-31
Vehicle loading information	10-15	Event Data Recorders (EDR)	10-32
Terms	10-15	Additional data recording (on vehicles equipped with optional ProPILOT Assist)	10-32
Vehicle load capacity	10-15		

Owner's manual/service manual
order information 10-33

CAPACITIES AND RECOMMENDED FLUIDS/LUBRICANTS

The following are approximate capacities. The actual refill capacities may be a little different. When refilling, follow the procedure instructed in the "8. Do-it-yourself" section to determine the proper refill capacity.

Fluid type			Capacity (approximate)			Recommended Fluids/Lubricants
			Metric Measure	US Measure	Imperial Measure	
Fuel			55 L	14-1/2 gal	12-1/8 gal	· See "Fuel information" (P.10-5).
Engine oil ¹ Drain and refill ¹ . For additional information, see "Changing engine oil and filter" (P.8-8).	PR25DD	With oil filter change	5.1 L	5-3/8 qt	4-1/2 qt	· Genuine "NISSAN Motor Oil 0W-20 SP" (or equivalent) is recommended. · If the above motor oil (or engine oil) is not available, a synthetic 0W-20 GF-6 SP motor oil (or engine oil) may be used. Damage caused by the use of motor oil (or engine oil) other than as recommended is not covered under NISSAN's New Vehicle Limited Warranty. For additional information, see "Engine oil and oil filter recommendation" (P.10-7).
		Without oil filter change	4.8 L	5-1/8 qt	4-1/4 qt	
	KR15DDT	With oil filter change	4.7 L	5 qt	4-1/8 qt	
		Without oil filter change	4.6 L	4-7/8 qt	4 qt	
Engine coolant	PR25DD	With reservoir	8.8 L	9-1/4 qt	7-3/4 qt	· Pre-diluted Genuine NISSAN Long Life Antifreeze/Coolant (blue) or equivalent
		Reservoir	0.8 L	7/8 qt	3/4 qt	
	KR15DDT	With reservoir	8.5 L	9 qt	7-1/2 qt	
		Reservoir	0.8 L	7/8 qt	3/4 qt	
Intercooler coolant		With reservoir	3 L	3-1/8 qt	2-5/8 qt	
		Reservoir	0.5 L	1/2 qt	1/2 qt	
Continuously Variable Transmission (CVT) fluid			—	—	—	· Genuine NISSAN CVT Fluid NS-3 · NISSAN recommends using Genuine NISSAN CVT Fluid NS-3 (or equivalent) ONLY in NISSAN CVTs. Do not mix with other fluids. Using fluids that are not equivalent to Genuine NISSAN CVT Fluid NS-3 may damage the CVT. Damage caused by the use of fluids other than as recommended is not covered under NISSAN's New Vehicle Limited Warranty.
Differential gear oil			—	—	—	· Genuine NISSAN HYPOID FLUID-S1 GL-5 75W-80 or equivalent
Transfer fluid			—	—	—	· Genuine NISSAN Differential Oil Hypoid Super-S GL-5 synthetic 75W-90 or equivalent
Brake fluid			Refill to the proper oil level according to the instructions in the "8. Do-it-yourself" section.			· Genuine NISSAN Super Heavy Duty Brake Fluid ² or equivalent DOT 3 ² ; Available in mainland U.S.A. through a NISSAN dealer.
Multi-purpose grease			—	—	—	· NLGI No. 2 (Lithium soap base)
Air conditioning system refrigerant			—	—	—	· See "Vehicle identification" (P.10-11) for air conditioner specification label. · HFO-1234yf (R-1234yf)
Air conditioning system oil			—	—	—	· See "Vehicle identification" (P.10-11) for air conditioner specification label. · A/C System Oil ND-OIL12(PAG) or equivalent
Window washer fluid	With liquid level sensor		5 L	1-3/8gal	1-1/8gal	· Genuine NISSAN Windshield Washer Concentrate Cleaner & Antifreeze or equivalent
	Without liquid level sensor		2.4 L	5/8gal	1/2gal	

Fluid type	Capacity (approximate)			Recommended Fluids/Lubricants
	Metric Measure	US Measure	Imperial Measure	
Coupling oil	—	—	—	Genuine NISSAN LSC Coupling Transmission Fluid 12-301 or equivalent.

FUEL INFORMATION

Use unleaded regular gasoline with an octane rating of at least 87 AKI (Anti-Knock Index) number (Research octane number 91).



CAUTION

- Using a fuel other than that specified could adversely affect the emission control system, and may also affect warranty coverage.
- Under no circumstances should a leaded gasoline be used, because this will damage the three-way catalyst.
- Do not use a fuel containing more than 15% ethanol in your vehicle. Your vehicle is not designed to run on a fuel containing more than 15% ethanol. Using a fuel containing more than 15% ethanol in a vehicle not specifically designed for a fuel containing more than 15% ethanol can adversely affect the emission control devices and systems of the vehicle. Damage caused by such fuel is not covered by the NISSAN new vehicle limited warranty.

- Do not use fuel that contains the octane booster methylcyclopentadienyl manganese tricarbonyl (MMT). Using fuel containing MMT may adversely affect vehicle performance and vehicle emissions. Not all fuel dispensers are labeled to indicate MMT content, so you may have to consult your gasoline retailer for more details. Note that Federal and California laws prohibit the use of MMT in reformulated gasoline.
- U.S. government regulations require ethanol dispensing pumps to be identified by a small, square, orange and black label with the common abbreviation or the appropriate percentage for that region.

Gasoline specifications

NISSAN recommends using gasoline that meets the World-Wide Fuel Charter (WWFC) specifications where it is available. Many of the automobile manufacturers developed this specification to improve emission control system and vehicle performance. Ask your service station manager if the gasoline meets the WWFC specifications.

Reformulated gasoline

Some fuel suppliers are now producing reformulated gasolines. These gasolines are specially designed to reduce vehicle emissions. NISSAN supports efforts towards cleaner air and suggests that you use reformulated gasoline when available.

Gasoline containing oxygenates

Some fuel suppliers sell gasoline containing oxygenates such as ethanol, MTBE and methanol with or without advertising their presence. NISSAN does not recommend the use of fuels of which the oxygenate content and the fuel compatibility for your vehicle cannot be readily determined. If in doubt, ask your service station manager.

If you use oxygenate-blend gasoline, please take the following precautions as the usage of such fuels may cause vehicle performance problems and/or fuel system damage.

- The fuel should be unleaded and have an octane rating no lower than that recommended for unleaded gasoline.
- If an oxygenate-blend, other than methanol blend is used, it should contain no more than 15% oxygenate.

- **If a methanol blend is used, it should contain no more than 5% methanol (methyl alcohol, wood alcohol). It should also contain a suitable amount of appropriate cosolvents and corrosion inhibitors. If not properly formulated with appropriate cosolvents and corrosion inhibitors, such methanol blends may cause fuel system damage and/or vehicle performance problems. At this time, sufficient data is not available to ensure that all methanol blends are suitable for use in NISSAN vehicles.**

If any driveability problems such as engine stalling and difficult hot-starting are experienced after using oxygenate-blend fuels, immediately change to a non-oxygenate fuel or a fuel with a low blend of MTBE.

Take care not to spill gasoline during refueling. Gasoline containing oxygenates can cause paint damage.

E-15 fuel

E-15 fuel is a mixture of approximately 15% fuel ethanol and 85% unleaded gasoline. E-15 can only be used in vehicles designed to run on E-15 fuel. U.S. government regulations require fuel ethanol dispensing pumps to be identified with small, square, orange and black label with the common abbreviation or the appropriate

percentage for that region.

E-85 fuel

E-85 fuel is a mixture of approximately 85% fuel ethanol and 15% unleaded gasoline. E-85 can only be used in a Flexible Fuel Vehicle (FFV). Do not use E-85 fuel in your vehicle. U.S. government regulations require fuel ethanol dispensing pumps to be identified by a small, square, orange and black label with the common abbreviation or the appropriate percentage for that region.

Fuel containing MMT

MMT, or methylcyclopentadienyl manganese tricarbonyl, is an octane boosting additive. NISSAN does not recommend the use of fuel containing MMT. Such fuel may adversely affect vehicle performance, including the emissions control system. Note that while some fuel pumps label MMT content, not all do, so you may have to consult your gasoline retailer for more details.

Aftermarket fuel additives

NISSAN does not recommend the use of any aftermarket fuel additives (for example, fuel injector cleaner, octane booster, intake valve deposit removers, etc.) which are sold commercially. Many of these additives intended for gum, varnish or

deposit removal may contain active solvent or similar ingredients that can be harmful to the fuel system and engine.

Octane rating tips

Using unleaded gasoline with an octane rating lower than recommended can cause persistent, heavy "spark knock". (Spark knock is a metallic rapping noise.) If severe, this can lead to engine damage. If you detect a persistent heavy spark knock even when using gasoline of the stated octane rating, or if you hear steady spark knock while holding a steady speed on level roads, it is recommended you have a NISSAN dealer correct the condition. Failure to correct the condition is misuse of the vehicle, for which NISSAN is not responsible.

Incorrect ignition timing will result in spark knock, after-run and/or overheating, which may cause excessive fuel consumption or engine damage. If any of the above symptoms are encountered, have your vehicle checked. It is recommended you visit a NISSAN dealer for servicing.

However, now and then you may notice light spark knock for a short time while accelerating or driving up hills. This is not a cause for concern, because you

get the greatest fuel benefit when there is light spark knock for a short time under heavy engine load.

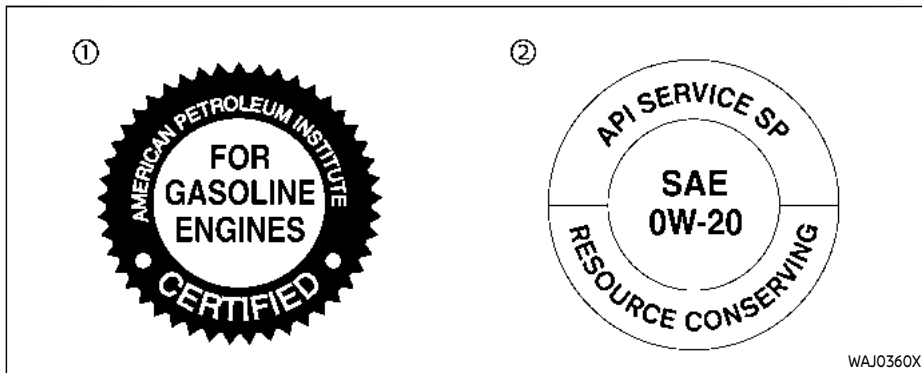

- ① API certification mark
- ② API service symbol

ENGINE OIL AND OIL FILTER RECOMMENDATION

Selecting the correct oil

It is essential to choose the correct grade, quality, and viscosity engine oil to ensure satisfactory engine life and performance, see "Capacities and recommended fluids/lubricants" (P.10-3). NISSAN recommends the use of an energy conserving oil in order to improve fuel economy.

Select only engine oils that meet the American Petroleum Institute (API) certification or International Lubricant Standar-

dization and Approval Committee (ILSAC) certification and SAE viscosity standard. These oils have the API certification mark on the front of the container. Oils which do not have the specified quality label should not be used as they could cause engine damage.

Oil additives

NISSAN does not recommend the use of oil additives. The use of an oil additive is not necessary when the proper oil type is used and maintenance intervals are followed.

Oil which may contain foreign matter or has been previously used should not be used.

Oil viscosity

The engine oil viscosity or thickness changes with temperature. Because of this, it is important to select the engine oil viscosity based on the temperatures at which the vehicle will be operated before the next oil change. Choosing an oil viscosity other than that recommended could cause serious engine damage.

Selecting the correct oil filter

Your new NISSAN vehicle is equipped with a high-quality genuine NISSAN oil filter. When replacing, use a genuine NISSAN oil filter or its equivalent for the reason described in "Change intervals".

Change intervals

The oil and oil filter change intervals for your engine are based on the use of the specified quality oils and filters. Using an engine oil and filter other than the specified quality, or exceeding recommended oil and filter change intervals could reduce engine life. Damage to the engine caused by improper maintenance or use of incorrect oil and filter quality and/or viscosity is not covered by the NISSAN new vehicle limited warranty.

Your engine was filled with a high quality engine oil when it was built. You do not have to change the oil before the first

recommended change interval.

Oil and filter change intervals depend upon how you use your vehicle. Operation under the following conditions may require more frequent oil and filter changes:

- repeated short distance driving at cold outside temperatures
- driving in dusty conditions
- extensive idling
- towing a trailer
- stop and go commuting
(See "9. Maintenance and schedules" section.)

AIR CONDITIONING SYSTEM REFRIGERANT AND LUBRICANT RECOMMENDATIONS

The air conditioner system in your NISSAN vehicle must be charged with the specified refrigerant HFO-1234yf (R-1234yf) and A/C system oil ND-OIL12 (PAG) or the exact equivalent.



CAUTION

The use of any other refrigerant or oil will cause severe damage to the air conditioning system and will require the replacement of all air conditioner

system components.

The refrigerant HFO-1234yf (R-1234yf) in your NISSAN vehicle will not harm the earth's ozone layer. Although this refrigerant does not affect the earth's atmosphere, certain government regulations require the recovery and recycling of any refrigerant during automotive air conditioner system service. Air conditioner system should only be serviced by trained and certified technicians to ensure proper and safe operation (SAE J2845). A NISSAN dealer has the trained technicians and equipment needed to recover and recycle your air conditioner system refrigerant. Only new and SAEJ2842 certified evaporator(s) shall be used as replacement parts.

A damaged or leaking air conditioning evaporator shall never be repaired or replaced with one removed from a used or salvaged vehicle. To replace a damaged or leaking evaporator, use only new and SAE J2842 certified evaporator (s). It is recommended that you visit a NISSAN dealer when servicing your air conditioner system.

SPECIFICATIONS

ENGINE

Model		PR25DD	KR15DDT
Type		Gasoline, 4-cycle, DOHC	Gasoline, 4-cycle, DOHC
Cylinder arrangement		4-cylinder, in-line	3-cylinder, in-line
Bore × Stroke	in (mm)	3.504 × 3.937 (89.0 × 100.0)	-
	when compression ratio = 8 in (mm)	-	3.307 × 3.547 (84.0 × 90.1)
	when compression ratio = 14 in (mm)	-	3.307 × 3.500 (84.0 × 88.9)
Displacement	cu in (cm ³)	151.85 (2,488)	-
	when compression ratio = 8 cu in (cm ³)	-	91.41 (1,497)
	when compression ratio = 14 cu in (cm ³)	-	90.19 (1,477)
Firing order		1-3-4-2	1-2-3
Idle speed	rpm		
Ignition timing (B.T.D.C.)	degree/rpm	No adjustment is necessary.	
Spark plug	Standard	DXE22H11C	ILMAR8G8GS
Spark plug gap (Normal)	in (mm)	0.043 (1.1)	0.031 (0.8)
Camshaft operation		Timing chain	Timing chain

This spark ignition system complies with the Canadian standard ICES-002.

WHEELS AND TIRES

Road wheel

Type	Size	Offset in (mm)
Conventional	17 × 7.5J	1.57 (40)
	18 × 7.5J	1.57 (40)
	19 × 7.5J	1.57 (40)
Spare	17 × 4T	1.18 (30)

Tire

Type	Size	Pressure PSI (kPa) [Cold]
Conventional	235/65 R17	Front: 36 (250)
		Rear: 33 (230)
	235/60 R18	Front: 33 (230)
	235/55 R19	Rear: 30 (210)
Spare	T155/80 D17 (2WD)	60 (420)
	T165/90 D17 (AWD)	

DIMENSIONS AND WEIGHTS

Overall length	in (mm)	182.9 (4,645)*1 183.5 (4,660)*2
Overall width	in (mm)	72.4 (1,840)
Overall height	in (mm)	67.9 (1,725)
Front tread	in (mm)	62.4 (1,585)
Rear tread	in (mm)	62.6 (1,590)
Wheelbase	in (mm)	106.5 (2,705)
Gross Vehicle Weight Rating (GVWR)	lb (kg)	See the F.M.V.S.S. or C.M.V.S.S. certification label on the driver's side center pillar.
Gross Axle Weight Rating (GAWR)		
Front	lb (kg)	
Rear	lb (kg)	

*1: Without license plate

*2: With license plate

WHEN TRAVELING OR REGISTERING IN ANOTHER COUNTRY

When planning to travel in another country, you should first find out if the fuel available is suitable for your vehicle's engine.

Using fuel with an octane rating that is too low may cause engine damage. All gasoline vehicles must be operated with unleaded gasoline. Therefore, avoid taking your vehicle to areas where appropriate fuel is not available.

When transferring the registration of your vehicle to another country, state, province or district, it may be necessary to modify the vehicle to meet local laws and regulations.

The laws and regulations for motor vehicle emission control and safety standards vary according to the country, state, province or district; therefore, vehicle specifications may differ.

When any vehicle is to be taken into another country, state, province or district and registered, its modifications, transportation, and registration are the responsibility of the user. NISSAN is not responsible for any inconvenience that may result.

VEHICLE IDENTIFICATION

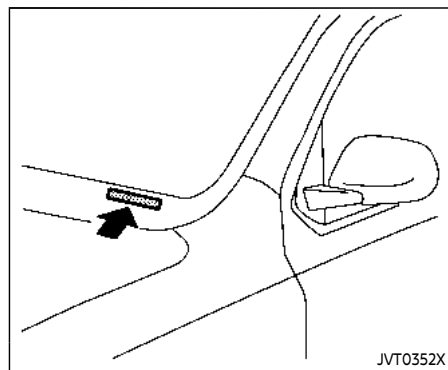

VEHICLE IDENTIFICATION NUMBER (VIN) PLATE

The vehicle identification number plate is attached as shown. This number is the identification for your vehicle and is used in the vehicle registration.

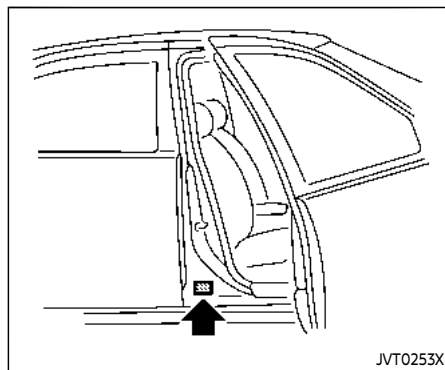

VEHICLE IDENTIFICATION NUMBER (chassis number)

The vehicle identification number is located as shown.

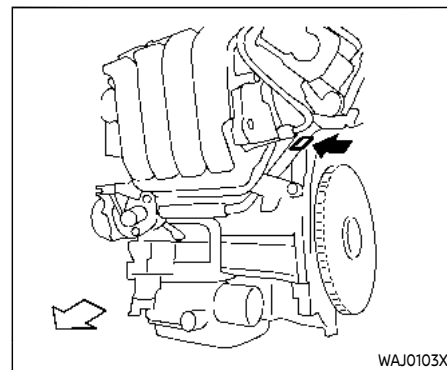

PR25DD engine

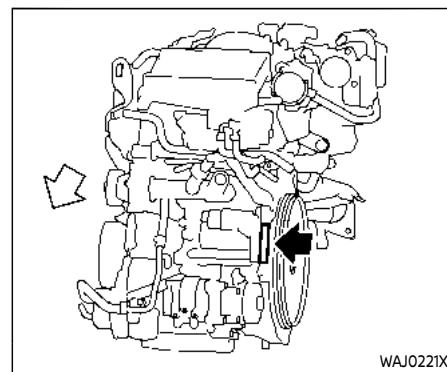

KR15DDT engine

ENGINE SERIAL NUMBER

The number is stamped on the engine as shown.

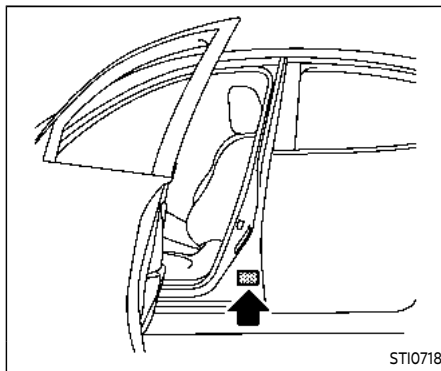

F.M.V.S.S./C.M.V.S.S. CERTIFICATION LABEL

The Federal/Canadian Motor Vehicle Safety Standards (F.M.V.S.S./C.M.V.S.S.) certification label is affixed as shown. This label contains valuable vehicle information, such as: Gross Vehicle Weight Ratings (GVWR), Gross Axle Weight Rating (GAWR), month and year of manufacture, Vehicle Identification Number (VIN), etc. Review it carefully.

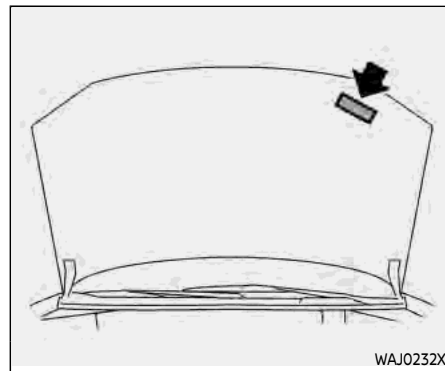

EMISSION CONTROL INFORMATION LABEL

The emission control information label is attached to the underside of the hood as shown.

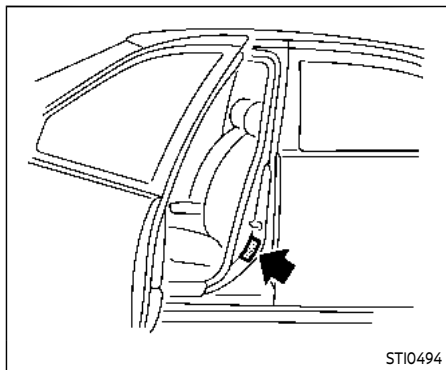



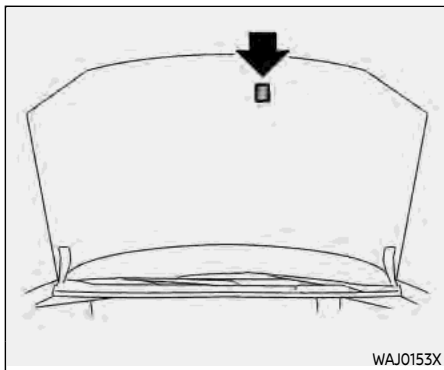

TIRE AND LOADING INFORMATION LABEL

The cold tire pressure is shown on the Tire and Loading Information label affixed to the pillar as shown.



AIR CONDITIONER SPECIFICATION LABEL

The air conditioner specification label is affixed to the underside of the hood as shown.

Air conditioner specification label symbols:		
Symbol Name	Reference	Graphic
Caution	ISO 7000 0434	
Air Conditioning System (MAC)	ISO 2575 D01	
MAC System Lubricant Type (PAG-POE)		
Requires Registered Technician to Service MAC System		
Flammable Refrigerant		

INSTALLING FRONT LICENSE PLATE

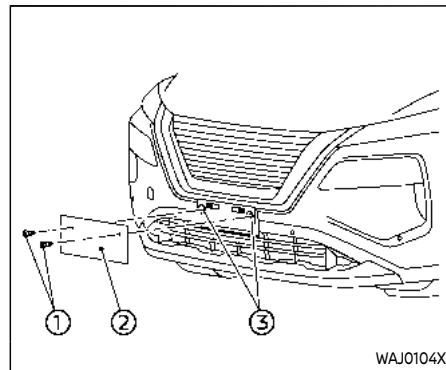

To mount the front license plate ②, attach the licence plate to the location marks (small dimples) ③ of the bumper using the two screws ① provided.

VEHICLE LOADING INFORMATION



WARNING

- It is extremely dangerous to ride in a cargo area inside the vehicle. In a collision, people riding in these areas are more likely to be seriously injured or killed.
- Do not allow people to ride in any area of your vehicle that is not equipped with seats and seat belts.
- Be sure everyone in your vehicle is in a seat and using a seat belt properly.

TERMS

It is important to familiarize yourself with the following terms before loading your vehicle:

- Curb Weight (actual weight of your vehicle) - vehicle weight including: standard and optional equipment, fluids, emergency tools, and spare tire assembly. This weight **does not** include

passengers and cargo.

- GVW (Gross Vehicle Weight) - curb weight plus the combined weight of passengers and cargo.
- GVWR (Gross Vehicle Weight Rating) - maximum total combined weight of the unloaded vehicle, passengers, luggage, hitch, trailer tongue load and any other optional equipment. This information is located on the F.M.V.S.S./C.M.V.S.S. label.
- GAWR (Gross Axle Weight Rating) - maximum weight (load) limit specified for the front or rear axle. This information is located on the F.M.V.S.S./C.M.V.S.S. label.
- GCWR (Gross Combined Weight Rating) - The maximum total weight rating of the vehicle, passengers, cargo, and trailer.
- Vehicle Capacity Weight, Load limit, Total load capacity - maximum total weight limit specified of the load (passengers and cargo) for the vehicle. This is the maximum combined weight of occupants and cargo that can

be loaded into the vehicle. If the vehicle is used to tow a trailer, the trailer tongue weight must be included as part of the cargo load. This information is located on the Tire and Loading Information label.

- Cargo capacity - permissible weight of cargo, the subtracted weight of occupants from the load limit.

VEHICLE LOAD CAPACITY

Do not exceed the load limit of your vehicle shown as "The combined weight of occupants and cargo" on the Tire and Loading Information label. Do not exceed the number of occupants shown as "Seating Capacity" on the Tire and Loading Information label.

To get "the combined weight of occupants and cargo", add the weight of all occupants, then add the total luggage weight. Examples are shown in the following illustration.

Example

$$\begin{array}{l} \text{Load limit} \\ 1,400 \text{ lb} \\ (640 \text{ kg}) \end{array} - \left(\begin{array}{l} \text{Occupants} \\ \text{Luggage} \\ \text{Trailer Tongue} \\ \text{Weight} \end{array} \right) = \begin{array}{l} \text{Remaining available} \\ \text{cargo and luggage} \\ \text{load capacity} = \\ 740 \text{ lb} \\ (336 \text{ kg}) \end{array}$$

150 lb x 2 = 300 lb (70 kg) (135 kg) + 30 lb x 2 = 60 lb (14 kg) (27 kg) + 300 lb (135 kg)

$$\begin{array}{l} \text{Load limit} \\ 1,400 \text{ lb} \\ (640 \text{ kg}) \end{array} - \left(\begin{array}{l} \text{Occupants} \\ \text{Luggage} \end{array} \right) = \begin{array}{l} \text{Remaining available} \\ \text{cargo and luggage} \\ \text{load capacity} = \\ 1,040 \text{ lb} \\ (472 \text{ kg}) \end{array}$$

150 lb x 2 = 300 lb (70 kg) (135 kg) + 30 lb x 2 = 60 lb (14 kg) (27 kg)

$$\begin{array}{l} \text{Load limit} \\ 1,400 \text{ lb} \\ (640 \text{ kg}) \end{array} - \left(\begin{array}{l} \text{Occupants} \\ \text{Luggage} \end{array} \right) = \begin{array}{l} \text{Remaining available} \\ \text{cargo and luggage} \\ \text{load capacity} = \\ 500 \text{ lb} \\ (227 \text{ kg}) \end{array}$$

150 lb x 5 = 750 lb (70 kg) (340 kg) + 30 lb x 5 = 150 lb (14 kg) (70 kg)

ST10445

Steps for determining correct load limit

1. Locate the statement "The combined weight of occupants and cargo should never exceed XXX kg or XXX lbs" on your vehicle's placard.
2. Determine the combined weight of the driver and passengers that will be riding in your vehicle.
3. Subtract the combined weight of the driver and passengers from XXX kg or XXX lbs.
4. The resulting figure equals the available amount of cargo and luggage load capacity. For example, if the XXX amount equals 1400 lbs. and there will be five 150 lb. passengers in your vehicle, the amount of available cargo and luggage load capacity is 650 lbs. (1400 - 750 (5 x 150) = 650 lbs) or (640 - 340 (5 x 70) = 300 kg.)
5. Determine the combined weight of luggage and cargo being loaded on the vehicle. That

weight may not safely exceed the available cargo and luggage load capacity calculated in Step 4.

Before driving a loaded vehicle, confirm that you do not exceed the Gross Vehicle Weight Rating (GVWR) or the Gross Axle Weight Rating (GAWR) for your vehicle. (See "Measurement of weights" (P.10-18).)

Also check tires for proper inflation pressures. See the Tire and Loading Information label.

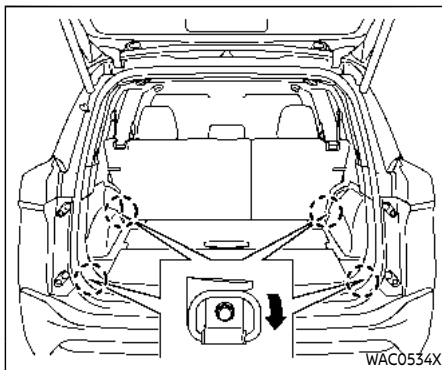

SECURING THE LOAD

There are luggage hooks located in the cargo area as shown. The hooks can be used to secure cargo with ropes or other types of straps.

Do not apply a total load of more than 22 lbs. (10 kg) to a single metal floor hook when securing cargo.



WARNING

- Properly secure all cargo with ropes or straps to help prevent it from sliding or shifting. Do not place cargo higher than the seat-

backs. In a sudden stop or collision, unsecured cargo could cause personal injury.

- The child restraint top tether strap may be damaged by contact with items in the cargo area. Secure any items in the cargo area. Your child could be seriously injured or killed in a collision if the top tether strap is damaged.
- Do not load your vehicle any heavier than the GVWR or the maximum front and rear GAWRs. If you do, parts of your vehicle can break, tire damage could occur, or it can change the way your vehicle handles. This could result in loss of control and cause personal injury.

LOADING TIPS

- The GVW must not exceed GVWR or GAWR as specified on the F.M. V.S.S./C.M.V.S.S. certification label.
- Do not load the front and rear axle to the GAWR. Doing so will exceed the GVWR.



WARNING

- Properly secure all cargo with ropes or straps to help prevent it from sliding or shifting. Do not place cargo higher than the seatbacks. In a sudden stop or collision, unsecured cargo could cause personal injury.
- Do not load your vehicle any heavier than the GVWR or the maximum front and rear GAWRs. If you do, parts of your vehicle can break, tire damage could occur, or it can change the way your vehicle handles. This could result in loss of control and cause personal injury.
- Overloading not only can shorten the life of your vehicle and the tire, but can cause unsafe vehicle handling and longer braking distances. This may cause a premature tire failure, which

could result in a serious accident and personal injury. Failures caused by overloading are not covered by the vehicle's warranty.

MEASUREMENT OF WEIGHTS

Secure loose items to prevent weight shifts that could affect the balance of your vehicle. When the vehicle is loaded, drive to a scale and weigh the front and the rear wheels separately to determine axle loads. Individual axle loads should not exceed either of the Gross Axle Weight Ratings (GAWR). The total of the axle loads should not exceed the Gross Vehicle Weight Rating (GVWR). These ratings are given on the vehicle certification label. If weight ratings are exceeded, move or remove items to bring all weights below the ratings.

TOWING A TRAILER



WARNING

Overloading or improper loading of a trailer and its cargo can adversely affect vehicle handling, braking and performance and may lead to accidents.



CAUTION

- Do not tow a trailer or haul a heavy load for the first 500 miles (800 km). Your engine, axle or other parts could be damaged.
- For the first 500 miles (800 km) that you tow a trailer, do not drive over 50 MPH (80 km/h) and do not make starts at full throttle. This helps the engine and other parts of your vehicle wear in at the heavier loads.

Your new vehicle was designed to be used primarily to carry passengers and cargo. Remember that towing a trailer places additional loads on your vehicle's engine, drivetrain, steering, braking and other systems.

A NISSAN Towing Guide (U.S. only) is

available on the website at www.nissanusa.com. This guide includes information on trailer towing capability and the special equipment required for proper towing.

MAXIMUM LOAD LIMITS

Maximum trailer loads

Never allow the total trailer load to exceed the value specified in the "Towing load/specification" (P.10-22) chart found in this section. The total trailer load equals trailer weight plus its cargo weight.

The maximum Gross Combined Weight Rating (GCWR) should not exceed the value specified in the following "Towing Load/Specification" chart.

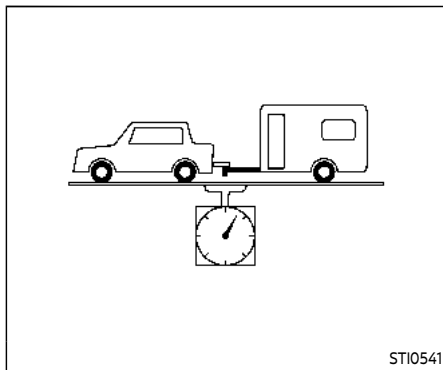

The GCWR equals the combined weight of the towing vehicle (including passengers and cargo) plus the total trailer load. Towing loads greater than these or using improper towing equipment could adversely affect vehicle handling, braking and performance.

The ability of your vehicle to tow a trailer is not only related to the maximum trailer loads, but also the places you plan to tow. Tow weights appropriate for level highway driving may have to be reduced for low traction situations (for example, on slippery boat ramps).

Temperature conditions can also affect towing. For example, towing a heavy

trailer in high outside temperatures on graded roads can affect engine performance and cause overheating. The transmission high fluid temperature and engine protection mode, which helps reduce the chance of transmission and engine damage, could activate and automatically decrease engine power. Vehicle speed may decrease under high load. Plan your trip carefully to account for trailer and vehicle load, weather and road conditions.



WARNING

Overheating can result in reduced engine power and vehicle speed. The reduced speed may be lower than other traffic, which could increase the chance of a collision. Be especially careful when driving. If the vehicle cannot maintain a safe driving speed, pull to the side of the road in a safe area. Allow the engine to cool and return to normal operation. (See "If your vehicle overheats" (P.6-14).)



CAUTION

Vehicle damage resulting from improper towing procedures is not covered by NISSAN warranties.

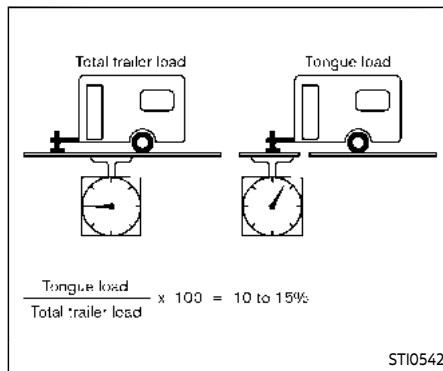

Tongue load

When using a weight carrying or a weight distributing hitch, keep the tongue load between 10 - 15% of the total trailer load or use the trailer tongue load specified by the trailer manufacturer. The tongue load must be within the maximum tongue load limits shown in the following "Towing Load/Specification" chart. If the tongue load becomes excessive, rearrange cargo to allow for proper tongue load.

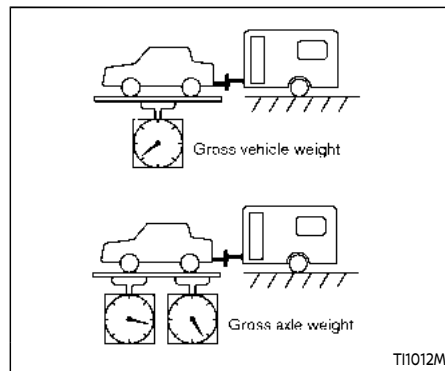

MAXIMUM GROSS VEHICLE WEIGHT (GVW)/MAXIMUM GROSS AXLE WEIGHT (GAW)

The GVW of the towing vehicle must not exceed the Gross Vehicle Weight Rating (GVWR) shown on the F.M.V.S.S./C.M.V.S.S. certification label. The GVW equals the combined weight of the unloaded vehicle, passengers, luggage, hitch, trailer tongue load and any other optional equipment. In addition, front or rear GAW must not exceed the Gross Axle Weight Rating (GAWR) shown on the F.M.V.S.S./C.M.V.S.S. certification label.

Towing capacities are calculated assuming a base vehicle with driver and any

options required to achieve the rating. Additional passengers, cargo and/or optional equipment, such as the trailer hitch, will add weight to the vehicle and reduce your vehicle's maximum towing capacity and trailer tongue load.

The vehicle and trailer need to be weighed to confirm the vehicle is within the GVWR, Front GAWR, Rear GAWR, Gross Combined Weight Rating (GCWR) and Towing capacity.

All vehicle and trailer weights can be measured using platform type scales commonly found at truck stops, highway weigh stations, building supply centers or salvage yards.

To determine the available payload capacity for tongue/king pin load, use the following procedure.

1. Locate the GVWR on the F.M.V.S.S./C.M.V.S.S. certification label.
2. Weigh your vehicle on the scale with all of the passengers and cargo that are normally in the vehicle when towing a trailer.
3. Subtract the actual vehicle weight from the GVWR. The remaining amount is the available maximum tongue/king pin load.

To determine the available towing capacity, use the following procedure.

1. Find the GCWR for your vehicle on the "Towing Load/Specification" chart found later in this section.
2. Subtract the actual vehicle weight from the GCWR. The remaining amount is the available maximum towing capacity.

To determine the Gross Trailer Weight, weigh your trailer on a scale with all equipment and cargo, that are normally in the trailer when it is towed. Make sure the Gross trailer weight is not more than the Gross Trailer Weight Rating shown on the trailer and is not more than the calculated available maximum towing capacity.

Also weigh the front and rear axles on the scale to make sure the Front Gross Axle Weight and Rear Gross Axle Weight are not more than Front Gross Axle Weight and Rear Gross Axle Weight on the F.M.V.S.S./C.M.V.S.S. certification label. The cargo in the trailer and vehicle may need to be moved or removed to meet the specified ratings.

Example:

- Gross Vehicle Weight (GVW) as weighed on a scale - including passengers, cargo and hitch - 6,350 lb. (2,880 kg).

- Gross Vehicle Weight Rating (GVWR) from F.M.V.S.S./C.M.V.S.S. certification label - 7,250 lb. (3,289 kg).
- Gross Combined Weight Rating (GCWR) from "Towing Load/Specification" chart - 15,100 lb. (6,849 kg).
- Maximum Trailer towing capacity from "Towing Load/Specification" chart - 9,100 lb (4,128 kg).

7,250 lb. (3,289 kg)	GVWR
- 6,350lb. (2,880 kg)	GVW
= 900 lb. (409 kg)	Available for tongue weight
15,100 lb. (6,849 kg)	GCWR
- 6,350 lb. (2,880 kg)	GVW
= 8,750 lb. (3,969 kg)	Capacity available for towing
900 lb. (409 kg) /	Available tongue weight
8,750 lb. (3,969 kg)	Available capacity
	= 10 % tongue weight

The available towing capacity may be less than the maximum towing capacity due to the passenger and cargo load in the vehicle.

Remember to keep trailer tongue weight between 10 - 15% of the trailer weight or within the trailer tongue load specification.

tion recommended by the trailer manufacturer. If the tongue load becomes excessive, rearrange the cargo to obtain the proper tongue load. Do not exceed the maximum tongue weight specification shown in the "Towing load/specification" chart even if the calculated available tongue weight is greater than 15%. If the calculated tongue weight is less than 10%, reduce the total trailer weight to match the available tongue weight.

Always verify that available capacities are within the required ratings.

TOWING LOAD/SPECIFICATION



WARNING

The towing capacities provided in this manual are for general reference only. The safe towing capacity of your vehicle is affected by dealer and factory installed options and passenger and cargo loads. You must weigh the vehicle and trailer as described in this manual to determine the actual vehicle towing capacity. Do not exceed the published maximum towing capacity, or the GCWR or the GVWR shown on the F.M.V.S.S./C.M.V.S.S. certification label. Doing so can result in an accident causing serious personal injury or property damage.

Towing load/specification chart				
Engine Type	PR25DD		KR15DDT	
Axle Type	Two-Wheel Drive (2WD)	All-Wheel Drive (AWD)	Two-Wheel Drive (2WD)	All-Wheel Drive (AWD)
Maximum Towing Capacity*1	1,350 lbs (612 kg)		1,500 lbs (680 kg)	
Maximum Tongue Load	135 lbs (61 kg)		150 lbs (68 kg)	
Maximum Gross Combined Weight Rating	5,836 lbs (2,647 kg)	5,969 lbs (2,707 kg)	6,053 lbs (2,745 kg)	6,185 lbs (2,805 kg)

- 1: The towing capacity values are calculated assuming a base vehicle with driver and any options required to achieve the rating. Additional passengers, cargo and/or optional equipment will add weight to the vehicle and reduce your vehicle's maximum towing capacity.

TOWING SAFETY

Trailer hitch

Choose a proper hitch for your vehicle and trailer. Make sure the trailer hitch is securely attached to the vehicle to help avoid personal injury or property damage due to sway caused by crosswinds, rough road surfaces or passing trucks.



WARNING

Trailer hitch components have specific weight ratings. Your vehicle may be capable of towing a trailer heavier than the weight rating of the hitch components. Never exceed the weight rating of the hitch components. Doing so can cause serious personal injury or property damage.

Hitch ball

Choose a hitch ball of the proper size and weight rating for your trailer:

- The required hitch ball size is stamped on most trailer couplers. Most hitch balls also have the size printed on top of the ball.
- Choose the proper class hitch ball based on the trailer weight.

- The diameter of the threaded shank of the hitch ball must be matched to the ball mount hole diameter. The hitch ball shank should be no more than 1/16' smaller than the hole in the ball mount.
- The threaded shank of the hitch ball must be long enough to be properly secured to the ball mount. There should be at least 2 threads showing beyond the lock washer and nut.

Ball mount

The hitch ball is attached to the ball mount and the ball mount is inserted into the hitch receiver. Choose a proper class ball mount based on the trailer weight. Additionally, the ball mount should be chosen to keep the trailer tongue level with the ground.

Weight carrying hitches

A weight carrying or "dead weight" ball mount is one that is designed to carry the whole amount of tongue weight and gross weight directly on the ball mount and on the receiver.

Weight distribution hitch

This type of hitch is also called a "load-leveling" or "equalizing" hitch. A set of bars attach to the ball mount and to the trailer to distribute the tongue weight (hitch weight) of your trailer. Many vehicles cannot carry the full tongue weight of a given trailer, and need some of the tongue weight transferred through the frame and pushing down on the front wheels. This gives stability to the tow vehicle.

A weight-distributing hitch system (Class IV) is recommended if you plan to tow trailers with a maximum weight over 5,000 lbs (2,267 kg). Check with the trailer and towing equipment manufacturers to determine if they recommend the use of a weight-distributing hitch system.

NOTE:

A weight-distributing hitch system may affect the operation of trailer surge brakes. If you are considering use of a weight-distributing hitch system with a surge brake-equipped trailer, check with the surge brake, hitch or trailer manufacturer to determine if and how this can be done.

Follow the instructions provided by the manufacturer for installing and using the weight-distributing hitch system.

General set-up instructions are as follows:

1. Park unloaded vehicle on a level surface. With the ignition switch in the ON position and the doors closed, allow the vehicle to stand for several minutes so that it can level.
2. Measure the height of a reference point on the front and rear bumpers at the center of the vehicle.
3. Attach the trailer to the vehicle and adjust the hitch equalizers so that the front bumper height is within 0 - .5 inches (0 - 13 mm) of the reference height measured in step 2. The rear bumper should be no higher than the reference height measured in step 2.



WARNING

Properly adjust the weight distributing hitch so the rear of the bumper is no higher than the measured reference height when the trailer is attached. If the rear bumper is higher than the measured reference height when loaded, the vehicle may handle unpredictably which could cause a loss of vehicle control and cause serious personal injury or property damage.

Sway control device

Sudden maneuvers, wind gusts and buffeting caused by other vehicles can affect trailer handling. Sway control devices may be used to help control these affects. If you choose to use one, contact a reputable trailer hitch supplier to make sure the sway control device will work with the vehicle, hitch, trailer and the trailer's brake system. Follow the instructions provided by the manufacturer for installing and using the sway control device.

Class I hitch

Class I trailer hitch equipment (receiver, ball mount and hitch ball) can be used to tow trailers of a maximum weight of 2,000 lb (907 kg).

Tire pressures

- When towing a trailer, inflate the vehicle tires to the recommended cold tire pressure indicated on the Tire and Loading Information label.
- Trailer tire condition, size, load rating and proper inflation pressure should be in accordance with the trailer and tire manufacturers' specifications.

Safety chains

Always use a suitable chain between your vehicle and the trailer. The safety chains should be crossed and should be attached to the hitch, not to the vehicle bumper or axle. Be sure to leave enough slack in the chains to permit turning corners.

Trailer lights (if so equipped)



CAUTION

When splicing into the vehicle electrical system, a commercially available power-type module/converter must be used to provide power for all trailer lighting. This unit uses the vehicle battery as a direct power source for all trailer lights while using the vehicle tail light, stoplight and turn signal circuits as a signal source. The module/converter must draw no more than 15 milliamps from the stop and tail lamp circuits. Using a module/converter that exceeds these power requirements may damage the vehicle's electrical system. See a reputable trailer retailer to obtain the proper equipment and to have it installed.

Trailer lights should comply with federal and/or local regulations. For assistance in hooking up trailer lights, contact a NISSAN dealer or reputable trailer retailer.

Pre-towing tips

- Be certain your vehicle maintains a level position when a loaded or unloaded trailer is hitched. Do not drive the vehicle if it has an abnormal nose-up or nose-down condition; check for improper tongue load, overload, worn suspension or other possible causes of either condition.
- Always secure items in the trailer to prevent load shift while driving.
- Keep the cargo load as low as possible in the trailer to keep the trailer center of gravity low.
- Load the trailer so approximately 60% of the trailer load is in the front half and 40% is in the back half. Also make sure the load is balanced side to side.
- Check your hitch, trailer tire pressure, vehicle tire pressure, trailer light operation, and trailer wheel lug nuts every time you attach a trailer to the vehicle.
- Be certain your rearview mirrors conform to all federal, state or local regulations. If not, install any mirrors required for towing before driving the

vehicle.

- Determine the overall height of the vehicle and trailer so the required clearance is known.

Trailer towing tips

In order to gain skill and an understanding of the vehicle's behavior, you should practice turning, stopping and backing up in an area which is free from traffic. Steering stability, and braking performance will be somewhat different than under normal driving conditions.

- Always secure items in the trailer to prevent load shift while driving.
- Lock the trailer hitch coupler with a pin or lock to prevent the coupler from inadvertently becoming unlatched.
- Avoid abrupt starts, acceleration or stops.
- Avoid sharp turns or lane changes.
- Always drive your vehicle at a moderate speed. Some states or provinces have specific speed limits for vehicles that are towing trailers. Obey the local speed limits.
- When backing up, hold the bottom of the steering wheel with one hand. Move your hand in the direction in which you want the trailer to go. Make small corrections and back up slowly. If possible, have someone guide you

when you are backing up.

Always block the wheels on both vehicle and trailer when parking. Parking on a slope is not recommended; however, if you must do so:



CAUTION

If you push the park button to engage the P (Park) position before blocking the wheels and applying the parking brake, transmission damage could occur.

1. Apply and hold the brake pedal.
2. Have someone place blocks on the downhill side of the vehicle and trailer wheels.
3. After the wheel blocks are in place, slowly release the brake pedal until the blocks absorb the vehicle load.
4. Apply the parking brake.
5. Push the park button to engage the P (Park) position.
6. Turn off the engine.

To drive away:

1. Apply and hold the brake pedal.
2. Start the engine.

3. Shift the transmission into gear.
 4. Release the parking brake.
 5. Drive slowly until the vehicle and trailer are clear from the blocks.
 6. Apply and hold the brake pedal.
 7. Have someone retrieve and store the blocks.
- While going downhill, the weight of the trailer pushing on the tow vehicle may decrease overall stability. Therefore, to maintain adequate control, reduce your speed and shift to a lower gear. Avoid long or repeated use of the brakes when descending a hill, as this reduces their effectiveness and could cause overheating. Shifting to a lower gear instead provides "engine braking" and reduces the need to brake as frequently.
 - If the engine coolant temperature rises to a high temperature, see "If your vehicle overheats" (P.6-14).
 - Trailer towing requires more fuel than normal circumstances.
 - Avoid towing a trailer for your vehicle's first 500 miles (800 km).
 - For the first 500 miles (800 km) that you do tow, do not drive over 50 MPH (80 km/h).

- Have your vehicle serviced more often than at intervals specified in the recommended maintenance schedule shown in the "9. Maintenance and schedules" section.
- When making a turn, your trailer wheels will be closer to the inside of the turn than your vehicle wheels. To compensate for this, make a larger than normal turning radius during the turn.
- Crosswinds and rough roads will adversely affect vehicle/trailer handling, possibly causing vehicle sway. When being passed by larger vehicles, be prepared for possible changes in crosswinds that could affect vehicle handling.

Do the following if the trailer begins to sway:

1. Take your foot off the accelerator pedal to allow the vehicle to coast and steer as straight ahead as the road conditions allow. This combination will help stabilize the vehicle.
 - Do not correct trailer sway by steering or applying the brakes.
2. When the trailer sway stops, gently apply the brakes and pull to the side of the road in a safe area.

3. Try to rearrange the trailer load so it is balanced as described earlier in this section.

- Be careful when passing other vehicles. Passing while towing a trailer requires considerably more distance than normal passing. Remember the length of the trailer must also pass the other vehicle before you can safely change lanes.
- Downshift the transmission to a lower gear for engine braking when driving down steep or long hills. This will help slow the vehicle without applying the brakes.
- Avoid holding the brake pedal down too long or too frequently. This could cause the brakes to overheat, resulting in reduced braking efficiency.
- Increase your following distance to allow for greater stopping distances while towing a trailer. Anticipate stops and brake gradually.
- NISSAN recommends that the cruise control not be used while towing a trailer.
- While towing a trailer, do not use the following systems (if so equipped):
 - Lane Departure Warning (LDW) system

- Intelligent Lane Intervention (I-LI) system
 - Blind Spot Warning (BSW) system
 - Intelligent Blind Spot Intervention (I-BSI) system
 - Rear Cross Traffic Alert (RCTA) system
 - ProPILOT Assist system (Intelligent Cruise Control (ICC), ProPILOT Assist with Navi-link and Steering Assist)
 - Automatic Emergency Braking (AEB) with Pedestrian Detection system
 - Intelligent Forward Collision Warning (I-FCW) system
 - Rear Automatic Braking (RAB) system
- Some states or provinces have specific regulations and speed limits for vehicles that are towing trailers. Obey the local speed limits.
 - Check your hitch, trailer wiring harness connections, and trailer wheel lug nuts after 50 miles (80 km) of travel and at every break.
 - When launching a boat, do not allow the water level to go over the exhaust tail pipe or rear bumper.
 - Make sure you disconnect the trailer lights before backing the trailer into

the water or the trailer lights may burn out.

When towing a trailer, the Continuously Variable Transmission (CVT) fluid, transfer fluid and differential gear oil should be changed more frequently. For additional information, see the "9. Maintenance and schedules" section.

FLAT TOWING

FLAT TOWING FOR ALL-WHEEL DRIVE VEHICLE (if so equipped)

Towing your vehicle with all four wheels on the ground is sometimes called flat towing. This method is sometimes used when towing a vehicle behind a recreational vehicle, such as a motor home.



CAUTION

- Failure to follow these guidelines can result in severe transmission damage.
- Never flat tow your All-Wheel Drive (AWD) vehicle.
- DO NOT tow your All-Wheel Drive (AWD) vehicle with any wheels on the ground. Doing so may cause serious and expensive damage to the powertrain.
- For emergency towing procedures refer to "Towing recommended by NISSAN" (P.6-16).

FLAT TOWING FOR FRONT-WHEEL DRIVE VEHICLE (if so equipped)

Towing your vehicle with all four wheels on the ground is sometimes called flat towing. This method is sometimes used when towing a vehicle behind a recreational vehicle, such as a motor home.



CAUTION

- Failure to follow these guidelines can result in severe transmission damage.
- Whenever flat towing your vehicle, always tow forward, never backward.
- Never tow your front wheel drive vehicle with the front tires on the ground. Doing so may cause serious and expensive damage to the powertrain.
- DO NOT tow your front wheel drive Continuously Variable Transmission (CVT) vehicle with all four wheels on the ground (flat towing). Doing so WILL DAMAGE internal transmission parts due to lack of transmission lubrication.

- For emergency towing procedures refer to “Towing recommended by NISSAN” in the “In case of emergency” section of this manual.

Continuously Variable Transmission (CVT)

To tow a vehicle equipped with a CVT, an appropriate vehicle dolly **MUST** be placed under the towed vehicle’s drive wheels. **Always** follow the dolly manufacturer’s recommendations when using their product.

UNIFORM TIRE QUALITY GRADING

DOT (Department Of Transportation) Quality Grades: All passenger car tires must conform to federal safety requirements in addition to these grades.

Quality grades can be found where applicable on the tire sidewall between tread shoulder and maximum section width. For example:

Treadwear 200 Traction AA Temperature A

TREADWEAR

The treadwear grade is a comparative rating based on the wear rate of the tire when tested under controlled conditions on a specified government test course. For example, a tire graded 150 would wear one and one-half

(1 1/2) times as well on the government course as a tire graded 100. The relative performance of tires depends upon actual conditions of their use, however, and may depart significantly from the norm due to variations in driving habits, service practices and differences in road characteristics and climate.

TRACTION AA, A, B AND C

The traction grades, from highest to lowest, are AA, A, B and C. Those grades represent the tire’s ability to stop on wet pavement as measured under controlled conditions on specified government test surfaces of asphalt and concrete. A tire marked C may have poor traction performance.



WARNING

The traction grade assigned to this tire is based on straight-ahead braking traction tests, and does not include acceleration, cornering, hydroplaning, or peak traction characteristics.

TEMPERATURE A, B AND C

The temperature grades A (the highest), B, and C, representing the tire’s resistance to the generation of heat and its ability to dissipate heat when tested under controlled conditions on a specified indoor laboratory test wheel. Sustained high temperature can cause the material of the tire to degenerate and reduce tire life, and excessive temperature can lead to sudden tire failure. The grade C corresponds to a level of performance which

all passenger car tires must meet under the Federal Motor Vehicle Safety Standard No. 109. Grades B and A represent higher levels of performance on the laboratory test wheel than the minimum required by law.



WARNING

The temperature grade for this tire is established for a tire that is properly inflated and not overloaded. Excessive speed, under-inflation, or excessive loading, either separately or in combination, can cause heat build-up and possible tire failure.

EMISSION CONTROL SYSTEM WARRANTY

Your vehicle is covered by the following emission warranties.

For USA:

- Emission Defects Warranty
- Emissions Performance Warranty

Details of these warranties may be found with other vehicle warranties in your Warranty Information Booklet which comes with your vehicle. If you did not receive a Warranty Information Booklet, or it has become lost, you may obtain a replacement by writing to:

- Nissan North America, Inc.
Consumer Affairs Department
P.O. Box 685003
Franklin, TN 37068-5003

For Canada:

Emission Control System Warranty

Details of this warranty may be found with other vehicle warranties in your Warranty Information Booklet which comes with your vehicle. If you did not receive a Warranty Information Booklet, or it has become lost, you may obtain a replacement by writing to:

- Nissan Canada Inc.
5290 Orbitor Drive
Mississauga, Ontario,
L4W 4Z5

REPORTING SAFETY DEFECTS

For USA

If you believe that your vehicle has a defect which could cause a crash or could cause injury or death, you should immediately inform the National Highway Traffic Safety Administration (NHTSA) in addition to notifying NISSAN.

If NHTSA receives similar complaints, it may open an investigation, and if it finds that a safety defect exists in a group of vehicles, it may order a recall and remedy campaign. However, NHTSA cannot become involved in individual problems between you, your dealer, or NISSAN.

To contact NHTSA, you may call the Vehicle Safety Hotline toll-free at 1-888- 327-4236 (TTY: 1-800-424-9153); go to <http://www.safercar.gov>; or write to: Administrator, NHTSA, 400 Seventh Street, SW., Washington, D.C. 20590. You can also obtain other information about motor vehicle safety from <http://www.safercar.gov>.

READINESS FOR INSPECTION/ MAINTENANCE (I/M) TEST

You may notify NISSAN by contacting our Consumer Affairs Department, toll-free, at 1-800-NISSAN-1.

For Canada

If you believe that your vehicle has a defect which could cause a crash or could cause injury or death, you should immediately inform Transport Canada in addition to notifying NISSAN.

If Transport Canada receives complaints, it may open an investigation, and if it finds that a safety defect exists in a group of vehicles, it may request that NISSAN conduct a recall campaign. However, Transport Canada cannot become involved in individual problems between you, your dealer, or NISSAN.

You may contact Transport Canada's Defect Investigations and Recalls Division toll free at 1-800-333-0510. You may also report safety defects online at: <https://wwwapps.tc.gc.ca/Saf-Sec-Sur/7/PCDB-BDPP/fc-cp.aspx?lang=eng> (English speakers) or <https://wwwapps.tc.gc.ca/Saf-Sec-Sur/7/PCDB-BDPP/fc-cp.aspx?lang=fra> (French speakers).

wwwapps.tc.gc.ca/Saf-Sec-Sur/7/PCDB-BDPP/fc-cp.aspx?lang=fra (French speakers).

Additional information concerning motor vehicle safety may be obtained from Transport Canada's Road Safety Information Centre at 1-800-333-0371 or online at www.tc.gc.ca/roadsafety (English speakers) or www.tc.gc.ca/securiteroutiere (French speakers).

To notify NISSAN of any safety concerns please contact our Consumer Information Centre toll free at 1-800-387-0122.



WARNING

A vehicle equipped with All-Wheel Drive (AWD) should never be tested using a two wheel dynamometer (such as the dynamometers used by some states for emissions testing), or similar equipment. Make sure you inform test facility personnel that your vehicle is equipped with AWD before it is placed on a dynamometer. Using the wrong test equipment may result in transmission damage or unexpected vehicle movement which could result in serious vehicle damage or personal injury.

Due to legal requirements in some states/ areas or provinces, your vehicle may be required to be in what is called the "ready condition" for an Inspection/Maintenance (I/M) test of the emission control system.

The vehicle is set to the "ready condition" when it is driven through certain driving patterns. Usually, the "ready condition" can be obtained by ordinary usage of the vehicle.

If a powertrain system component is repaired or the battery is disconnected, the vehicle may be reset to a "not ready

EVENT DATA RECORDERS (EDR)

condition". Before taking the I/M test, check the vehicle's inspection/maintenance test readiness condition. Place the ignition switch in the ON position without starting the engine. If the Malfunction Indicator Light (MIL) comes on steady for 20 seconds and then blinks for 10 seconds, the I/M test condition is "not ready". If the MIL does not blink after 20 seconds, the I/M test condition is "ready".

It is recommended you visit a NISSAN dealer to set "ready condition" or to prepare the vehicle for testing.

This vehicle is equipped with an Event Data Recorder (EDR). The main purpose of an EDR is to record, in certain crash or near crash-like situations, such as an air bag deployment or hitting a road obstacle, data that will assist in understanding how a vehicle's systems performed. The EDR is designed to record data related to vehicle dynamics and safety systems for a short period of time, typically 30 seconds or less. The EDR in this vehicle is designed to record such data as:

- How various systems in your vehicle were operating;
- Whether or not the driver and passenger safety belts were buckled/fastened;
- How far (if at all) the driver was depressing the accelerator and/or brake pedal; and,
- How fast the vehicle was traveling.
- Sounds are not recorded.

These data can help provide a better understanding of the circumstances in which crashes and injuries occur.

NOTE: EDR data are recorded by your vehicle only if a nontrivial crash situation occurs; no data are recorded by the EDR under normal driving conditions and no personal data (e.g. name, gender, age and crash location) are recorded. However, other parties, such as law enforcement,

could combine the EDR data with the type of personally identifying data routinely acquired during a crash investigation.

To read data recorded by an EDR, special equipment is required and access to the vehicle or the EDR is needed. In addition to the vehicle manufacturer and NISSAN dealer, other parties, such as law enforcement, that have the special equipment, can read the information if they have access to the vehicle or the EDR. EDR data will only be accessed with the consent of the vehicle owner or lessee or as otherwise required or permitted by law.

ADDITIONAL DATA RECORDING (on vehicles equipped with optional ProPILOT Assist)

If your vehicle is equipped with the optional ProPILOT Assist, it will also be equipped with supplemental data recording function intended to assist in understanding how ProPILOT Assist performs in certain nontrivial crash or near-crash scenarios. Specifically, supplemental recording is designed to capture the following:

- Driver operational status of the accelerator, brakes, steering, etc.
- Detection status of a vehicle ahead and lane markers

OWNER'S MANUAL/SERVICE MANUAL ORDER INFORMATION

- Vehicle information including distance to vehicle ahead and lateral position
 - Information on the operation of the ProPILOT Assist and other crash avoidance features
 - ProPILOT Assist malfunction diagnosis information
 - External images from the multi-sensing front camera (Available only when the SRS air bag or AEB with Pedestrian Detection system is activated)
- In response to an official request from law enforcement, court order, governmental agency, or other legally enforceable request
 - For research purposes after the data is modified such that it is no longer tied to a specific vehicle or vehicle owner (anonymized)

The ProPILOT Assist does not record conversations, sounds or images of the inside of the vehicle.

To read this supplemental data, special equipment is required and access to the vehicle or the recording unit is needed. This supplemental data will only be accessed with the consent of the vehicle owner or lessee or as otherwise required or permitted by law. If downloaded, NISSAN and third parties entrusted by NISSAN may use the data recorded for the purpose of improving NISSAN's vehicle safety performance.

NISSAN and third parties entrusted by NISSAN will not disclose/provide the recorded data to a third party except:

- With the consent of the vehicle owner or with the consent of the lessee

Genuine NISSAN Service Manuals for this model year and prior can be purchased. A genuine NISSAN Service Manual is the best source of service and repair information for your vehicle. This manual is the same one used by the factory trained technicians working at a NISSAN dealer. Genuine NISSAN Owner's Manuals can also be purchased.

In the USA:

For current pricing and availability of genuine **NISSAN Service Manuals** contact:

www.nissan-techinfo.com

For current pricing and availability of genuine **NISSAN Owner's Manuals** contact:

1-800-247-5321

In Canada:

To purchase a copy of a genuine NISSAN Service Manual or Owner's Manual for this model year and prior please contact a NISSAN dealer. For the phone number and location of a NISSAN dealer in your area call the NISSAN Information Center at 1-800-387-0122 and a bilingual NISSAN representative will assist you.

MEMO

MEMO

MEMO

11 Index

A

ABS (Anti-lock Braking System)	5-156
Active noise cancellation.....	5-175
Active Ride Control	5-160
Active sound enhancement.....	5-175
Adjustable luggage floor	2-76
Advanced Air Bag System.....	1-53
Air bag system	
Advanced Air Bag System.....	1-53
Driver and front passenger supplemental knee air bag system.....	1-62
Front and rear seat-mounted side-impact supplemental air bag system.....	1-64
Front central seat-mounted side-impact supplemental air bag system.....	1-64
Front passenger air bag and status light.....	1-55
Roof-mounted curtain side-impact supplemental air bag system.....	1-64
Air bag warning labels	1-67
Air bag warning light.....	1-67, 2-16
Air cleaner housing filter	8-18
Air conditioner	
Air conditioner operation.....	4-27
Air conditioner service.....	4-38
Air conditioner specification label.....	10-13
Air conditioning system refrigerant and lubricant recommendations.....	4-38
Air conditioning system refrigerant and oil recommendations.....	10-8
Alarm, How to stop alarm (see vehicle security system).....	2-54
Alcohol, drugs and driving.....	5-12

Alert	
Rear Door Alert.....	2-68
All-Wheel Drive (AWD) (See Intelligent 4x4).....	5-151
Android Auto.....	4-2
Antenna.....	4-39
Anti-lock Braking System (ABS).....	5-156
Anti-lock Braking System (ABS) warning light.....	2-17
Appearance care	
Exterior appearance care.....	7-2
Interior appearance care.....	7-4
Apple CarPlay®.....	4-2
Armrest.....	1-10
Audible reminders.....	2-22
AUTO mode.....	5-32
Automatic	
Door locks.....	3-7
Automatic air conditioner and heater.....	4-32, 4-35
Automatic brake hold.....	5-28
Automatic Emergency Braking (AEB) system OFF warning light.....	2-17
Automatic Emergency Braking (AEB) with Pedestrian Detection system.....	5-122
Automatic moonroof and sunshade.....	2-86
Average fuel consumption.....	2-47
Average speed.....	2-47
Avoiding collision and rollover.....	5-10
AWD (See Intelligent 4x4).....	5-151

B

Battery.....	8-14
Battery replacement, Intelligent Key....	8-24
Battery saver system.....	2-63

Variable voltage control system.....	8-16
Before starting the engine.....	5-17
Blind Spot Warning (BSW).....	5-58
Booster seats.....	1-44
Brake	
Anti-lock Braking System (ABS).....	5-156
Brake fluid.....	8-12
Brake system.....	5-155
Electronic parking brake system warning light.....	2-18
Parking brake.....	5-25
Warning light.....	2-14
Break-in schedule.....	5-149
Brightness control	
Instrument panel.....	2-11
Bulb check/instrument panel.....	2-14
Bulb replacement.....	8-27

C

Capacities and recommended fluids/lubricants.....	10-3
Car phone or CB radio.....	4-39
Card holder.....	2-80
Cargo cover.....	2-81
Cargo light.....	2-90
Catalytic converter, Three way catalyst.....	5-6
Charger	
USB (Universal Serial Bus) charging connector.....	2-70
Wireless charger.....	2-70
Chassis control.....	5-160
Child restraints.....	1-25
Booster seats.....	1-44
LATCH system.....	1-27
Precautions on child restraints.....	1-25

Child safety.....	1-22
Child safety rear door lock.....	3-7
Chimes	
Seat belt warning light and chime.....	1-17, 2-16
Chimes, Audible reminders.....	2-22
Circuit breaker, Fusible link.....	8-22
Cleaning exterior and interior.....	7-2, 7-4
Clock.....	2-49
Coat hook.....	2-80
Cockpit.....	2-3
Cold weather driving.....	5-173
Connection to Roadside Assistance.....	6-2
Console box.....	2-79
Continuously Variable Transmission (CVT) fluid.....	8-12
Continuously Variable Transmission (CVT) position indicator.....	2-11
Conventional (fixed speed) cruise control mode (with ProPILOT Assist).....	5-119
Coolant	
Capacities and recommended fluids/lubricants.....	10-3
Changing engine coolant.....	8-6
Changing intercooler coolant.....	8-8
Checking engine coolant level.....	8-6
Checking intercooler coolant level.....	8-7
Corrosion protection.....	7-7
Cover, Cargo cover.....	2-81
Cruise control	
Conventional (fixed speed) cruise control mode.....	5-119
Cruise control (with ProPILOT Assist) (See Conventional (fixed speed) cruise control mode).....	5-119
Cruise control (without ProPILOT Assist).....	5-83

Intelligent Cruise Control (ICC).....	5-98
Cup holders.....	2-74
CVT, Driving with CVT (Continuously Variable Transmission).....	5-19

D

Daytime Running Lights (DRL) system.....	2-64
Defroster switch, Rear window and outside mirror defroster switch.....	2-57
Dimensions and weights.....	10-10
Display	
Head Up Display (HUD).....	2-50
Vehicle information display.....	2-22
Drive belt.....	8-16
Drive Computer.....	2-47
Drive Mode Selector.....	5-31
Driver and front passenger supplemental knee air bag.....	1-62
Driver Assistance systems.....	5-35
Common troubleshooting guide.....	5-40
Driving	
Cold weather driving.....	5-173
Drive Mode Selector.....	5-31
Driving with CVT (Continuously Variable Transmission).....	5-19
Intelligent 4x4.....	5-151
On-pavement and off-road driving.....	5-10
Precautions when starting and driving.....	5-5
Safety precautions.....	5-12

E

Easy-Fill Tire Alert system.....	5-9
ECO mode.....	5-32

ECO mode system	
ECO Drive Report.....	2-11
Economy, Fuel.....	5-150
Elapsed time.....	2-47
Electric power steering.....	5-154
Electric power steering warning light.....	2-17
Electric shift control system warning light.....	2-15
Emergency Call (SOS) button.....	2-73
Emission control information label.....	10-12
Emission control system warranty.....	10-30
Engine	
Before starting the engine.....	5-17
Break-in schedule.....	5-149
Capacities and recommended fluids/lubricants.....	10-3
Changing engine coolant.....	8-6
Changing engine oil and filter.....	8-8
Checking engine coolant level.....	8-6
Checking engine oil level.....	8-8
Coolant temperature gauge.....	2-9
Emergency engine shut off.....	5-16, 6-3
Engine compartment	
check locations.....	8-3
Engine cooling system.....	8-4
Engine oil.....	8-8
Engine oil and oil filter recommendation.....	10-7
Engine oil viscosity.....	10-8
Engine serial number.....	10-12
Engine specifications.....	10-9
Engine start operation indicator.....	2-35
If your vehicle overheats.....	6-14
Remote engine start.....	3-19
Starting the engine.....	5-18
Event Data Recorders (EDR).....	10-32
Exhaust gas (carbon monoxide).....	5-5

Explanation of scheduled maintenance items.....	9-5
-------------------------------------------------	-----

F

F.M.V.S.S./C.M.V.S.S. certification label.....	10-12
Filter	
Air cleaner housing filter.....	8-18
Changing engine oil and filter.....	8-8
Flashers (See hazard warning flasher switch).....	6-2
Flat tire.....	6-3
Flat towing.....	10-28
Floor mat cleaning.....	7-5
Fluid	
Brake fluid.....	8-12
Capacities and recommended fluids/lubricants.....	10-3
Continuously Variable Transmission (CVT) fluid.....	8-12
Engine coolant.....	8-4
Engine oil.....	8-8
Intercooler coolant.....	8-6
Window washer fluid.....	8-13
Fog light switch.....	2-65
Forward Driving Aids.....	5-35
Front manual seat adjustment.....	1-5
Front passenger air bag and status light.....	1-55
Front seat, Front seat adjustment.....	1-5
Fuel	
Capacities and recommended fluids/lubricants.....	10-3
Fuel economy.....	5-150
Fuel information.....	10-5
Fuel octane rating.....	10-5
Fuel-filler door.....	3-29

Gauge.....	2-10
Fuel Efficient Driving Tips.....	5-149
Fuses.....	8-21
Fusible links.....	8-22

G

Garage mode system.....	3-27
Gauge.....	2-5
Engine coolant temperature gauge.....	2-9
Fuel gauge.....	2-10
Odometer.....	2-8
Speedometer.....	2-8
Tachometer.....	2-9
General maintenance.....	9-2
Glove box.....	2-78

H

Hazard warning flasher switch.....	6-2
Head restraints/headrests.....	1-11
Head Up Display (HUD).....	2-50
Headlights	
Bulb replacement.....	8-28
Headlight switch.....	2-58
Heated seats.....	2-66
Heated steering wheel.....	2-66
Heater	
Heater and air conditioner operation.....	4-27
High beam assist.....	2-61
Hill start assist system.....	5-161
Hood release.....	3-22
Hook	
Coat hook.....	2-80
Luggage hook.....	2-81

Horn.....	2-65
-----------	------

I

Ignition switch.....	5-14
Ignition switch positions.....	5-15
Immobilizer system.....	2-54
Indicator	
Lights.....	2-17
Vehicle information display.....	2-22
indicator light	
Electronic parking brake warning light.....	2-15
Inside mirror.....	3-33
Inspection/maintenance (I/M) test.....	10-31
Instrument brightness control.....	2-11
Instrument panel.....	2-4
Intelligent 4x4.....	5-151
Intelligent Around View® Monitor.....	4-10
Intelligent Auto Headlight system.....	2-59
Intelligent Blind Spot Intervention (I-BSI).....	5-66
Intelligent Cruise Control (ICC).....	5-98
Intelligent Driver Alertness (I-DA).....	5-141
Intelligent Forward Collision Warning (I-FCW).....	5-132
Intelligent Key button operation light.....	3-17
Intelligent Key system.....	3-7
Key operating range.....	3-9
Key operation.....	3-11
Remote keyless operation.....	3-15
Intelligent Lane Intervention (I-LI).....	5-52
Intelligent Trace Control.....	5-160
Intercooler cooling system.....	8-6
Interior light replacement.....	8-28
Interior light switch.....	2-89
Interior lights.....	2-88

ISOFIX child restraint 1-27

J

Jump starting 6-11

K

Key

Ignition switch positions 5-15

Keyless entry

With Intelligent Key system
(See Intelligent Key system)..... 3-15

Keys 3-3

For Intelligent Key system..... 3-7

KR15DDT engine model 8-4

L

Labels

Air bag warning labels 1-67

Air conditioner specification label..... 10-13

Emission control information label ... 10-12

Engine serial number 10-12

F.M.V.S.S./C.M.V.S.S.

certification label 10-12

Tire and Loading

information label..... 8-32, 10-13

Vehicle identification number (VIN) ... 10-11

Lane Departure Warning (LDW) 5-47

LATCH system 1-27

License plate, installing front

license plate..... 10-14

Liftgate 3-23

Auto closure 3-28

Liftgate release lever 3-28

Operating manual liftgate..... 3-23

Operating power liftgate..... 3-24

Light

Air bag warning light..... 1-67

Bulb replacement..... 8-27

Cargo light..... 2-90

Fog light switch..... 2-65

Headlight switch 2-58

Headlights bulb replacement..... 8-28

Indicator lights..... 2-17

Interior lights..... 2-88

Map lights..... 2-89

Rear personal lights 2-90

Room lights..... 2-89

Vanity mirror lights 2-90

Warning lights, indicator lights and

audible reminders..... 2-14

Lights, Exterior and interior

light replacement..... 8-28

Loading information (See vehicle

loading information) 10-15

Lock

Automatic door locks..... 3-7

Door locks..... 3-5

Power door lock 3-5

Low tire pressure warning (Tire

Pressure Low)..... 2-36

Low tire pressure warning light 2-18

Low tire pressure warning system

(See Tire Pressure Monitoring

System (TPMS))..... 5-6

Lower console tray 2-79

Luggage

Adjustable luggage floor 2-76

Single luggage board..... 2-76

Luggage hooks 2-81

M

Maintenance

Battery..... 8-14

General maintenance..... 9-2

Maintenance precautions..... 8-2

Maintenance requirements..... 9-2

Maintenance schedules..... 9-7

Seat belt maintenance..... 1-22

Standard maintenance..... 9-8

Maintenance schedules..... 9-7

Malfunction indicator light (MIL)..... 2-19

Manual air conditioner and heater..... 4-28

Manual front seat adjustment..... 1-5

Map lights..... 2-89

Master warning light..... 2-16, 2-20

Mechanical key (Intelligent Key system)..... 3-4

Memory seat 3-37

Meters and gauges..... 2-5

Instrument brightness control 2-11

Mirror

Inside mirror..... 3-33

Outside mirrors..... 3-35

Vanity mirror 3-36

Moonroof..... 2-86

Moving Object Detection (MOD) 4-22

N

Neutral hold mode..... 5-22

New vehicle break-in..... 5-149

NISSAN Vehicle Immobilizer System 2-54

O

Odometer..... 2-8

OFF-ROAD mode..... 5-32

Off-road recovery.....	5-11
Oil	
Capacities and recommended fluids/lubricants.....	10-3
Changing engine oil and filter.....	8-8
Checking engine oil level.....	8-8
Engine oil.....	8-8
Engine oil viscosity.....	10-8
Oil control system.....	2-29, 9-7
Other lights.....	2-21
Outside air temperature.....	2-49
Outside mirrors.....	3-35
Overheat, If your vehicle overheats.....	6-14
Owner's Manual/Service Manual order information.....	10-33

P

Panic alarm.....	3-17
Parking	
Brake break-in.....	5-155
Parking brake.....	5-25
Parking on hills.....	5-153
Parking Aids.....	5-35
Parking brake	
Electronic parking brake warning light.....	2-15
Power	
Electric power steering.....	5-154
Power door lock.....	3-5
Power outlet.....	2-69
Power windows.....	2-83
PR25DD engine model.....	8-3
Precautions	
Braking precautions.....	5-155
Child restraints.....	1-25
Driving safety.....	5-12

Maintenance.....	8-2
On-pavement and off-road driving.....	5-10
Seat belt usage.....	1-15
SRS.....	1-47
When starting and driving.....	5-5
ProPILOT Assist.....	5-85
ProPILOT Assist with Navi-link.....	5-85
Speed Adjust by Route.....	5-106
Speed Limit Assist.....	5-103
Push starting.....	6-14
Push-button ignition switch.....	5-14

R

RAB system.....	5-143
Rapid air pressure loss.....	5-11
Readiness for inspection/maintenance (I/M) test.....	10-31
Rear Automatic Braking (RAB).....	5-143
Rear Automatic Braking (RAB) system	
OFF warning light.....	2-20
Rear Cross Traffic Alert (RCTA).....	5-77
Rear Door Alert.....	2-68
Rear door lock, Child safety rear door lock.....	3-7
Rear Driving Aids.....	5-35
Rear personal lights.....	2-90
Rear seats.....	1-8
Rear Sonar System (RSS).....	5-168
Rear sunshade.....	3-32
Rear window and outside mirror defroster switch.....	2-57
Rear window wiper and washer switch.....	2-56
RearView Monitor.....	4-3
Recorders, Event data.....	10-32
Registering in another country.....	10-10
Remote engine start.....	3-19

Remote keyless entry function, For	
Intelligent Key system.....	3-15
Reporting safety defects.....	10-30
Road Assistance.....	6-2
Rollover.....	5-10
Roof rack.....	2-82
Room lights.....	2-89

S

Safety	
Child seat belts.....	1-22
Reporting safety defects.....	10-30
Towing safety.....	10-23
Seat adjustment	
Front manual seat adjustment.....	1-5
Front power seat adjustment.....	1-6
Front seats.....	1-5
Seat belt(s)	
Child safety.....	1-22
Infants.....	1-23
Injured persons.....	1-18
Larger children.....	1-23
Precautions on seat belt usage.....	1-15
Pregnant women.....	1-18
Seat belt cleaning.....	7-7
Seat belt extenders.....	1-21
Seat belt hook.....	1-21
Seat belt maintenance.....	1-22
Seat belt warning light and chime.....	1-17, 2-16
Seat belts.....	1-15
Seat belts with pretensioners.....	1-66
Shoulder belt height adjustment.....	1-20
Small children.....	1-23
Three-point type with retractor.....	1-18

Seat(s)	
Heated seats	2-66
Memory seat	3-37
Seats	1-3
Security system (NISSAN Vehicle Immobilizer System), Engine start	2-54
Security system, Vehicle security system	2-53
Servicing air conditioner	4-38
Shifting	
CVT (Continuously Variable Transmission)	5-19
Shoulder belt height adjustment, For front seats	1-20
Side Driving Aids	5-35
Single luggage board	2-76
SNOW mode	5-32
Soft bottle holders	2-75
Sonar	
Rear Automatic Braking (RAB)	5-143
Rear Sonar System (RSS)	5-168
Sonar system	5-162
SOS button (See Emergency Call (SOS) button)	2-73
Spare tire	8-41, 10-10
Spark plugs	8-17
Speed Adjust by Route (ProPILOT Assist with Navi-link)	5-106
Speed Limit Assist (ProPILOT Assist with Navi-link)	5-103
Speedometer	2-8
SPORT mode	5-34
SRS	
Precautions on SRS	1-47
Standard maintenance	9-8
STANDARD mode	5-32

Starting	
Before starting the engine	5-17
Jump starting	6-11
Precautions when starting and driving	5-5
Push starting	6-14
Starting the engine	5-18
Status light, Front passenger air bag	1-55
Steering	
Electric power steering	5-154
Heated steering wheel	2-66
Tilt/telescopic steering	3-31
Steering Assist	5-113
Steering Assist switch	2-67
Storage	2-74
Sun visors	3-32
Sunglasses holder	2-79
Sunshade (rear)	3-32
Supplemental air bag warning labels	1-67
Supplemental air bag warning light	1-67, 2-16
Supplemental Restraint System (SRS) switch	1-47
Drive Mode Selector	5-31
Emergency Call (SOS) button	2-73
Fog light switch	2-65
Hazard warning flasher switch	6-2
Headlight switch	2-58
Intelligent Auto Headlight switch	2-59
Memory seat switch	3-37
Power door lock switch	3-6
Rear window and outside mirror defroster switch	2-57
Steering Assist switch	2-67
Turn signal switch	2-64
Wiper and washer switch	2-55

T

Tachometer	2-9
Temperature gauge, Engine coolant temperature gauge	2-9
Theft (NISSAN Vehicle Immobilizer System), Engine start	2-54
Three-way catalyst	5-6
Tilt/telescopic steering	3-31
Tire pressure, Low tire pressure warning light	2-18
Tires	
Easy-Fill Tire Alert system	5-9
Flat tire	6-3
Low tire pressure warning system	5-6
Tire and Loading information label	8-32, 10-13
Tire chains	8-37
Tire dressing	7-4
Tire pressure	8-30
Tire pressure monitoring system (TPMS)	5-6, 6-3
Tire rotation	8-38
Types of tires	8-36
Uniform tire quality grading	10-29
Wheel/tire size	10-10
Wheels and tires	8-30
Towing	
Tow truck towing	6-15
Towing a trailer	10-18
Towing safety	10-23
TPMS, Tire pressure monitoring system	5-6
TPMS with Easy Fill Tire Alert	5-9
TPMS, Tire pressure warning system	6-3
Traffic Sign Recognition (TSR)	5-44
Trailer towing	10-18

Transmission	
Continuously Variable Transmission (CVT) fluid.....	8-12
Driving with CVT (Continuously Variable Transmission).....	5-19
Transmitter, With Intelligent Key system (See Intelligent Key system).....	3-15
Traveling or registering in another country.....	10-10
Trip computer.....	2-47
Trip odometer.....	2-47
Troubleshooting guide	
Driver Assistance systems.....	5-40
Turbocharger system.....	5-6
Turn signal switch.....	2-64

U

Underbody cleaning.....	7-3
Uniform tire quality grading.....	10-29
USB (Universal Serial Bus) charging connector.....	2-70

V

Vanity mirror.....	3-36
Vanity mirror lights.....	2-90
Variable Compression Turbo.....	2-12
Variable voltage control system.....	8-16
Vehicle	
Dimensions and weights.....	10-10
Identification number (VIN).....	10-11
Loading information.....	10-15
Recovery (freeing a stuck vehicle).....	6-17
Security system.....	2-53
Vehicle Dynamic Control (VDC) system.....	5-157

Vehicle information display.....	2-22
Settings.....	2-24
Vehicle information display warnings and indicators.....	2-35
Vehicle Speed.....	2-47
Ventilators.....	4-26

W

Warning	
Blind Spot Warning (BSW).....	5-58
Driver Assistance systems troubleshooting guide.....	5-40
Hazard warning flasher switch.....	6-2
Intelligent Forward Collision Warning (I-FCW).....	5-132
Lane Departure Warning (LDW).....	5-47
Lights.....	2-14
Low tire pressure warning.....	2-36
Rear Door Alert.....	2-68
Tire pressure monitoring system (TPMS).....	5-6, 6-3
Vehicle information display.....	2-22
Warning lights, indicator lights and audible reminders.....	2-13
Warning labels, Air bag warning labels.....	1-67
Warning light	
Air bag warning light.....	1-67, 2-16
Anti-lock Braking System (ABS) warning light.....	2-17
Brake warning light.....	2-14
Electric power steering warning light.....	2-17
Electric shift control system warning light.....	2-15
Electronic parking brake system warning light.....	2-18

Low tire pressure warning light.....	2-18
Seat belt warning light and chime.....	1-17, 2-16
Warranty, Emission control system warranty.....	10-30
Washer switch	
Rear window wiper and washer operation.....	2-56
Wiper and washer switch.....	2-55
Washing.....	7-2
Waxing.....	7-3
Weights (See dimensions and weights).....	10-10
Wheel/tire size.....	10-10
Wheels and tires.....	8-30
Care of wheels.....	7-3
Cleaning aluminum alloy wheels.....	7-3
Window washer fluid.....	8-13
Window(s)	
Cleaning.....	7-3
Power windows.....	2-83
Wiper	
Rear window wiper blade.....	8-20
Wiper and washer switch.....	2-55
Wiper blades.....	8-19
Wiper and washer switch.....	2-55
Wireless charger.....	2-70

MEMO

MEMO

MEMO

MEMO

GAS STATION INFORMATION

FUEL INFORMATION:

Use unleaded regular gasoline with an octane rating of at least 87 AKI (Anti-Knock Index) number (Research octane number 91).



CAUTION

- Using a fuel other than that specified could adversely affect the emission control system, and may also affect warranty coverage.
- Under no circumstances should a leaded gasoline be used, because this will damage the three-way catalyst.
- Do not use a fuel containing more than 15% ethanol in your vehicle. Your vehicle is not designed to run on a fuel containing more than 15% ethanol. Using a fuel containing more than 15% ethanol in a vehicle not specifically designed for a fuel containing more than 15% ethanol can adversely affect the emission control devices and systems of the vehicle. Damage caused by such

fuel is not covered by the NISSAN new vehicle limited warranty.

- Do not use fuel that contains the octane booster methylcyclopentadienyl manganese tricarbonyl (MMT). Using fuel containing MMT may adversely affect vehicle performance and vehicle emissions. Not all fuel dispensers are labeled to indicate MMT content, so you may have to consult your gasoline retailer for more details. Note that Federal and California laws prohibit the use of MMT in reformulated gasoline.
- U.S. government regulations require ethanol dispensing pumps to be identified by a small, square, orange and black label with the common abbreviation or the appropriate percentage for that region.

For additional information, see "Capacities and recommended fluids/lubricants" (P.10-3).

ENGINE OIL RECOMMENDATION:

See "Capacities and recommended fluids/lubricants" (P.10-3) for engine oil and oil filter recommendation.

COLD TIRE PRESSURES:

For additional information, see "Tire and Loading Information label" (P.10-13).

The label is typically located on the driver side center pillar. For additional information, see "Wheels and tires" (P.8-30).

NEW VEHICLE BREAK-IN PROCEDURES RECOMMENDATION:

During the first 1,200 miles (2,000 km) of vehicle use, follow the recommendations outlined in the "Break-in schedule" (P.5-149) of this Owner's Manual. Follow these recommendations for the future reliability and economy of your new vehicle.



To view the digital NissanConnect manual, go to
www.nissanquickguide.com/rogue/2022/browse
or snap this QR code with an appropriate QR code reader.

Printing : October 2021
Publication No.: OM22EA 0T33U0
Printed in the U.S.A.

T33-D