



[owners.honda.com](http://owners.honda.com) (U.S.)  
[myhonda.ca](http://myhonda.ca) (Canada)

31T0AG01  
 00X31-T0A-G011

2015 Honda CR-V Owner's Guide  
 ©2014 Honda Motor Co., Ltd. — All Rights Reserved

Printed in U.S.A.



**2015**  
**OWNER'S GUIDE**

# DISCLOSURES

## ■ Devices That Emit Radio Waves

The following products and systems on your vehicle emit radio waves when in operation:

- Audio system
- Bluetooth® Audio
- Bluetooth® HandsFreeLink®
- HomeLink® Universal Transceiver
- Collision Mitigation Braking System™ (CMBST™)
- Immobilizer system
- Remote transmitter
- Smart Entry System
- Tire Pressure Monitoring System

Each of the above complies with the appropriate requirements or the required standards of the FCC (Federal Communications Commission) and Industry Canada, described below:

*As required by the FCC:*

*This device complies with Part 15 of the FCC rules. Operation is subject to the following two conditions: (1) This device may not cause harmful interference, and (2) this device must accept any interference received, including interference that may cause undesired operation.*

*Changes or modifications not expressly approved by the party responsible for compliance could void the user's authority to operate the equipment.*

*As required by Industry Canada:*

*This device complies with Industry Canada Standard RSS-Gen/210/310. Operation is subject to the following two conditions: (1) this device may not cause interference, and (2) this device must accept any interference, including interference that may cause undesired operation of the device.*

## ■ California Perchlorate Contamination Prevention Act

The airbags, seat belt tensioners, and CR-type batteries in this vehicle may contain perchlorate materials—special handling may apply. See [www.dtsc.ca.gov/hazardouswaste/perchlorate/](http://www.dtsc.ca.gov/hazardouswaste/perchlorate/) for more information.

## ■ California Proposition 65 Warning

**WARNING:** This product contains or emits chemicals known to the state of California to cause cancer and birth defects or other reproductive harm.

## ■ Event Data Recorders

**This vehicle is equipped with an event data recorder (EDR).** The main purpose of an EDR is to record, in certain crash or near crash-like situations, such as an air bag deployment or hitting a road obstacle, data that will assist in understanding how a vehicle's systems performed. **The EDR is designed to record data related to vehicle dynamics and safety systems for a short period of time, typically 30 seconds or less. The EDR in this vehicle is designed to record such data as:**

- **How various systems in your vehicle were operating;**
- **Whether or not the driver and passenger safety belts were buckled/fastened;**
- **How far (if at all) the driver was depressing the accelerator and/or brake pedal; and,**
- **How fast the vehicle was traveling.**

These data can help provide a better understanding of the circumstances in which crashes and injuries occur. NOTE: EDR data are recorded by your vehicle only if a non-trivial crash situation occurs; no data are recorded by the EDR under normal driving conditions and no personal data (e.g., name, gender, age, and crash location) are recorded. However, other parties, such as law enforcement, could combine the EDR data with the type of personally identifying data routinely acquired during a crash investigation.

To read data recorded by an EDR, special equipment is required, and access to the vehicle or the EDR is needed. In addition to the vehicle manufacturer, other parties such as law enforcement that have the special equipment can read the information if they have access to the vehicle or the EDR.

The data belong to the vehicle owner and may not be accessed by anyone else except as legally required or with the permission of the vehicle owner.

## ■ Service Diagnostic Recorders

This vehicle is equipped with service-related devices that record information about powertrain performance. The data can be used to verify emissions law requirements and/or help technicians diagnose and solve service problems. It may also be combined with data from other sources for research purposes, but it remains confidential.

# INTRODUCTION

This Owner's Guide is intended to help you quickly get acquainted with your 2015 Honda CR-V. It provides basic information and instructions on technology and convenience features, as well as emergency procedures and how to get assistance.

This guide is for vehicles sold in the United States and Canada. It covers all CR-V models, so you may find descriptions of features and equipment that are not in your vehicle. Images throughout this guide are from U.S. vehicles and represent features and equipment that are available on some, but not all, models.

This guide is not intended to be a substitute for the Owner's Manual. The Owner Information CD enclosed in your glove box kit includes the Owner's Manual, Navigation Manual, and vehicle and tire warranties in electronic format. This information can be viewed on a computer (PC or Mac platform) and saved or printed for your reference. You can also visit [owners.honda.com](http://owners.honda.com) (U.S.) or [myhonda.ca](http://myhonda.ca) (Canada) to view the complete and most current information.

If you are the first registered owner of your vehicle, you may request a complimentary printed copy of the Owner's Manual, Navigation Manual, or Vehicle Warranty within the first six months of vehicle purchase. To request a copy, visit [owners.honda.com](http://owners.honda.com) (U.S.) and create or log in to your account. In Canada, please request a copy from your Honda dealer.

American Honda Motor Company strives to be proactive in protecting our environment and natural resources. By using electronic delivery for a considerable portion of the information typically found in a vehicle owner's manual, we are further reducing our impact on the environment.

## Honda Automobile Customer Service

Your authorized Honda dealer should be able to answer any questions you have about your vehicle. However, if you are dissatisfied with the information you receive, you can call Honda Automobile Customer Service (see page 142).

**Call (800) 999-1009 (U.S.) or (888) 946-6329 (Canada)**

## Honda Roadside Assistance

24-hour emergency road service is available to you in the United States and Canada throughout your 3-year/36,000-mile warranty term. Services include jump starting, flat tire and lockout assistance, towing, and more (limitations apply).

**Call (866) 864-5211 (U.S.) or (800) 465-7587 (Canada)**

# TABLE OF CONTENTS

VISUAL INDEX .....	1	HomeLink® Garage Opener* .....	49
Steering Wheel and Nearby Controls...1		Air Conditioning System* .....	50
Dashboard and Ceiling Controls ....2		Climate Control System* .....	51
SAFETY INFORMATION .....	3	Seat Heaters* .....	52
Important Safety Information .....	3	Setting the Clock.....	53
Seat Belts .....	5	AUDIO AND CONNECTIVITY .....	54
Airbags.....	9	Basic Audio Operation.....	54
Child Safety .....	15	<i>Models with one display</i>	
Safety Label Locations.....	22	Intelligent Multi-Information	
Reporting Safety Defects.....	23	Display (i-MID) .....	57
INSTRUMENT PANEL .....	24	FM/AM Radio .....	58
Malfunction Indicators .....	24	Compact Disc (CD) .....	59
Condition Indicators .....	26	iPod® .....	60
On/Off Indicators .....	27	USB Flash Drive .....	61
Information Display* .....	28	Bluetooth® Audio .....	62
Multi-Information Display (MID)* ..	29	Pandora® .....	63
Customized Features .....	31	<i>Models with touchscreen</i>	
VEHICLE CONTROLS .....	32	Touchscreen Operation* .....	64
Using the Key or Remote Transmitter...32		HondaLink™ .....	65
Smart Entry System* .....	33	FM/AM Radio .....	66
Door Operation .....	34	SiriusXM® Radio* .....	67
Tailgate Operation* .....	35	Compact Disc (CD) .....	68
Power Tailgate Operation* .....	36	iPod® .....	69
Power Window Operation .....	37	USB Flash Drive .....	70
Power Moonroof Operation* .....	38	Bluetooth® Audio .....	71
Interior and Exterior Lights .....	39	Pandora® .....	72
One-Touch Turn Signal.....	40	HDMI Video .....	73
Wiper Operation.....	41	BLUETOOTH® HANDSFREELINK®	
Adjusting the Seats .....	42	(HFL).....	74
Rear Seats .....	46	<i>Models with one display</i>	
Driving Position Memory System* ...	47	Basic HFL Operation.....	74
Adjusting the Steering Wheel .....	47	Pairing a Phone .....	75
Adjusting the Mirrors.....	48	Making a Call .....	76
		SMS Text Messaging .....	77

\*if equipped

# VISUAL INDEX

Quickly locate items in the vehicle's interior.

## Steering Wheel and Nearby Controls

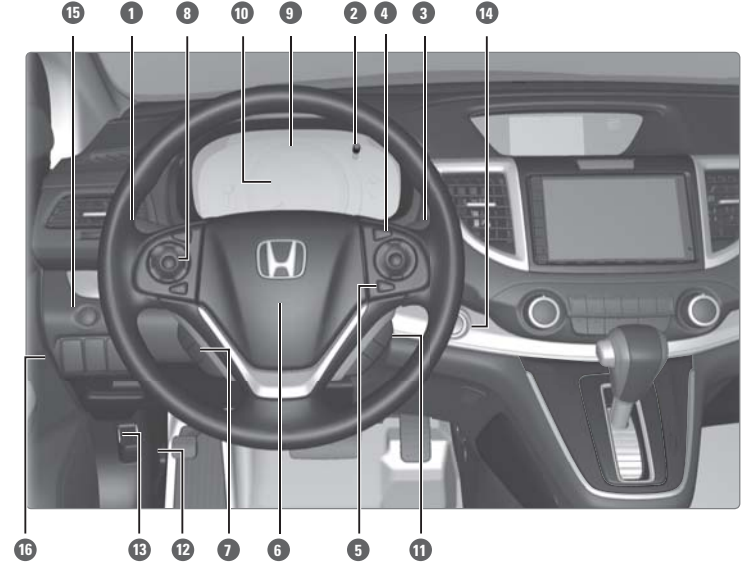

- ① Lights/turn signals/LaneWatch button\* p. 39, p. 40, p. 107
- ② SEL/RESET knob\* p. 28  
Brightness control p. 39
- ③ Wipers/washers p. 41
- ④ Cruise control\*/Adaptive cruise control (ACC)\* buttons p. 101, p. 102
- ⑤ Lane Keeping Assist System (LKAS) button p. 105
- ⑥ Horn
- ⑦ Voice recognition buttons p. 74, p. 78, p. 86
- ⑧ Audio controls p. 55  
i-MID button\* p. 57
- ⑨ Instrument panel p. 24
- ⑩ Information display\* p. 28  
Multi-Information Display (MID)\* p. 29
- ⑪ INFO buttons\* p. 29  
SEL/RESET button\* p. 29
- ⑫ Hood release handle p. 125
- ⑬ Fuel fill door handle p. 110
- ⑭ ENGINE START/STOP button\* p. 97
- ⑮ ECON button\* p. 100
- ⑯ Vehicle Stability Assist (VSA®) OFF button p. 100  
Lane Departure Warning (LDW) button\* p. 104  
Power tailgate button\* p. 36  
Tire Pressure Monitoring System (TPMS) button\* p. 115  
Collision Mitigation Braking System™ (CMBS™) button\* p. 106  
Heated windshield button\* p. 51

\*if equipped

\*if equipped

Models with touchscreen

Basic HFL Operation.....	78	Shift Lever Does Not Move .....	112
Pairing a Phone .....	80	Overheating.....	113
Making a Call .....	81	Emergency Engine Stop* .....	114
SMS Text Messaging and E-Mail* ..	83	Emergency Towing .....	114
HondaLink™ Assist .....	84	Tire Pressure Monitoring System (TPMS) .....	115
Siri™ Eyes Free .....	84	Changing a Flat Tire.....	116
NAVIGATION* .....	85	Fuse Locations.....	119
Entering a Destination .....	88	MAINTENANCE .....	122
Routing .....	90	Safety Precautions .....	122
DRIVING .....	92	Maintenance Minder™.....	123
Before Driving .....	92	Under the Hood.....	125
Maximum Load Limit.....	94	Engine Oil .....	126
Towing a Trailer .....	96	Engine Coolant .....	128
Starting to Drive .....	97	Checking the Battery.....	129
Braking .....	99	Window Washer Fluid .....	129
Vehicle Stability Assist (VSA®), aka Electronic Stability Control (ESC) System.....	100	Changing Wiper Blades.....	130
Eco Assist System.....	100	Tire Information.....	132
Cruise Control* .....	101	Tire Labeling .....	135
Adaptive Cruise Control (ACC)* ...	102	DOT Tire Quality Grading.....	136
Lane Departure Warning (LDW)* ...	104	Tire Pressure Monitoring System (TPMS) - Required Federal Explanation .....	138
Lane Keeping Assist System (LKAS)* .....	105	Testing of Readiness Codes .....	139
Collision Mitigation Braking System™ (CMBS™)* .....	106	SPECIFICATIONS .....	140
LaneWatch™* .....	107	CUSTOMER INFORMATION.....	141
Multi-View Rear Camera* .....	108	Frequently Asked Questions/ Troubleshooting .....	141
Multi-View Rear Camera* .....	109	Contact Us .....	142
Refueling .....	110	Honda Roadside Assistance .....	143
HANDLING THE UNEXPECTED ...	111	Warranty Coverages.....	143
Smart Entry Remote Battery Strength.....	111	VOICE COMMAND INDEX.....	144
Jump Starting .....	111	INDEX .....	151



## Dashboard and Ceiling Controls

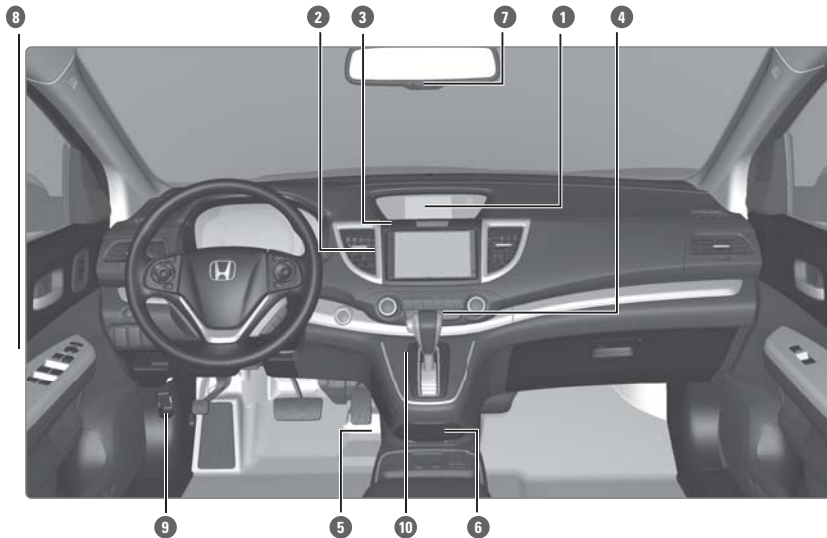

- 1 Intelligent Multi-Information Display (i-MID) p. 57
- 2 Touchscreen\* p. 64
- 3 Hazard warning button
- 4 Climate control system p. 51
- 5 Seat heater switches\* p. 52
- 6 USB/HDMI\* port p. 54  
Auxiliary input jack p. 55  
Accessory power socket p. 54

- 7 Moonroof switch\* p. 38  
Map lights p. 39  
HomeLink® buttons\* p. 49
- 8 Power window switches p. 37  
Door lock switches p. 34  
Door mirror controls p. 48  
Driving Position Memory System buttons\* p. 47
- 9 Parking brake p. 99
- 10 Shift lever p. 98

\*if equipped

## SAFETY INFORMATION

Your safety—and the safety of others—is very important, and operating this vehicle safely is an important responsibility. While we strive to help you make informed decisions about safety, it is not practical or possible to warn you about all the hazards associated with operating or maintaining your vehicle. Therefore, you must use your own good judgment.

### Important Safety Information

This guide explains many of your vehicle's safety features and how to use them. Please read this information carefully. Following the instructions below will also help to keep you and your passengers safe.

#### ■ Important Safety Precautions

- Always wear your seat belt.
- Secure all children in the proper restraint system.
- Be aware of airbag hazards.
- Don't drink and drive.
- Pay appropriate attention to the task of driving safely.
- Control your speed.
- Keep your vehicle in safe condition.

Engaging in cell phone conversation or other activities that keep you from paying close attention to the road, other vehicles, and pedestrians could lead to a crash. Remember, situations can change quickly, and only you can decide when it is safe to divert some attention away from driving.

#### ■ Safety Messages

When you see the following messages throughout this guide, pay close attention.

**⚠ DANGER** You WILL be KILLED or SERIOUSLY HURT if you don't follow instructions.

**⚠ WARNING** You CAN be KILLED or SERIOUSLY HURT if you don't follow instructions.

**⚠ CAUTION** You CAN be HURT if you don't follow instructions.

**NOTICE** This information is intended to help you avoid damage to your vehicle, other property, or the environment.

## ■ Important Handling Information

Your vehicle has higher ground clearance than a passenger vehicle designed for use only on pavement. Higher ground clearance has many advantages for off-highway driving. It allows you to travel over bumps, obstacles, and rough terrain. It also provides good visibility so you can anticipate problems earlier.

These advantages come at some cost. Because your vehicle is taller and rides higher off the ground, it has a higher center gravity making it more susceptible to tripping or rollover if you make abrupt turns. Utility vehicles have a significantly higher rollover rate than other types of vehicles. In a rollover crash, an unbelted person is significantly more likely to die than a person wearing a seat belt. As a reminder, make sure you and your passengers always wear seat belts.

## ■ Carbon Monoxide Gas

The engine exhaust from this vehicle contains carbon monoxide, a colorless, odorless, and highly toxic gas. As long as you properly maintain your vehicle and follow the instructions set forth below, you will not accumulate dangerous levels of carbon monoxide gas in the vehicle interior.

Have the exhaust system inspected for leaks whenever:

- The exhaust system is making an unusual noise.
- The exhaust system may have been damaged.
- The vehicle is raised for an oil change.

When you operate a vehicle with the tailgate open, airflow can pull exhaust gas into the interior and create a hazardous condition. If you must drive with the tailgate open, open all the windows and set the climate control system as shown below.

1. Select the fresh air mode.
2. Select the  mode.
3. Set the fan speed to high.
4. Set the temperature control to a comfortable setting.

Adjust the climate control system in the same manner if you sit in your parked vehicle with the engine running.

### **WARNING**

Carbon monoxide gas is toxic. Breathing it can cause unconsciousness and even kill you.

Avoid any enclosed areas or activities that expose you to carbon monoxide.

An enclosed area such as a garage can quickly fill up with carbon monoxide gas. Do not run the engine with the garage door closed. Even when the garage door is open, drive out of the garage immediately after starting the engine.

## Seat Belts

A seat belt is your best protection in all types of collisions. Airbags are designed to supplement seat belts, not replace them. So even though your vehicle is equipped with airbags, make sure you and your passengers always wear your seat belts and wear them properly.

### ■ Lap/Shoulder Seat Belts

All five seating positions are equipped with lap/shoulder seat belts with emergency locking retractors. In normal driving, the retractor lets you move freely while keeping some tension on the belt. During a collision or sudden stop, the retractor locks to restrain your body. The rear seat belts also have a lockable retractor for use with child seats.

The front seats are equipped with automatic seat belt tensioners to enhance safety. The tensioners automatically tighten the front seat belts during a moderate to severe frontal collision, sometimes even if the collision is not severe enough to inflate the front airbags.

### ■ Proper Use of Seat Belts

Follow these guidelines for proper use:

- All occupants should sit upright, well back in the seat, and remain in that position for the duration of the trip. Slouching and leaning reduces the effectiveness of the belt and can increase the chance of serious injury in a crash.
- Never place the shoulder part of a lap/shoulder seat belt under your arm or behind your back. This could cause very serious injuries in a crash.
- Two people should never use the same seat belt. If they do, they could be very seriously injured in a crash.
- Do not put any accessories on the seat belts. Devices intended to improve comfort or reposition the shoulder part of a seat belt can reduce the protective capability and increase the chance of serious injury in a crash.
- No one should sit in a seat with an inoperative seat belt or one that does not appear to be working correctly. Using a seat belt that is not working properly may not protect the occupant in a crash. Have a dealer check the belt as soon as possible.

### **WARNING**

Not wearing a seat belt properly increases the chance of a serious injury or death in a crash, even though your vehicle has airbags.

Be sure you and your passengers always wear seat belts and wear them properly.

## ■ Seat Belt Inspection

Regularly check the condition of your seat belts as follows:

- Pull each belt out fully, and look for frays, cuts, burns, and wear.
- Check that the latches work smoothly and the belts retract easily. If a belt does not retract easily, cleaning the belt may correct the problem. Use only mild soap and warm water. Do not use bleach or cleaning solvents. Make sure the belt is completely dry before allowing it to retract.

Any belt that is not in good condition or working properly will not provide proper protection and should be replaced as soon as possible.

A belt that has been worn during a crash may not provide the same level of protection in a subsequent crash. Have your seat belts inspected by a dealer after any collision.

### ⚠️ WARNING

Not checking or maintaining seat belts can result in serious injury or death if the seat belts do not work properly when needed.

Check your seat belts regularly and have any problem corrected as soon as possible.

## ■ Fastening a Seat Belt

Adjust your seat to the proper position (see page 42), and then follow the below steps.

1. Pull the seat belt out slowly.
2. Insert the latch plate into the buckle, then tug on the belt to make sure the buckle is secure. Make sure that the belt is not twisted or caught on anything.
3. Position the lap part of the belt as low as possible across your hips, then pull up on the shoulder part of the belt so the lap part fits snugly. This lets your strong pelvic bones take the force of a crash and reduces the chance of internal injuries.
4. If necessary, pull up on the belt again to remove any slack, then make sure that the belt rests across the center of your chest and over your shoulder. This spreads the forces of a crash over the strongest bones in your upper body.

To release the belt, push the red PRESS button then guide the belt by hand until it has retracted completely.

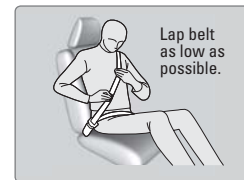
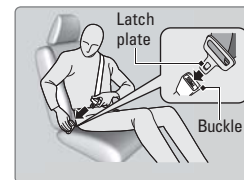

### ⚠️ WARNING

Improperly positioning the seat belts can cause serious injury or death in a crash.

Make sure all seat belts are properly positioned before driving.

## ■ Adjusting the Shoulder Anchor

The front seats have adjustable shoulder anchors to accommodate taller and shorter occupants.

1. Move the anchor up and down while holding the release buttons.
2. Position the anchor so that the belt rests across the center of your chest and over your shoulder.

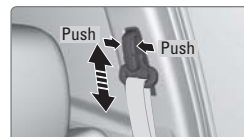

## ■ Seat Belt with Detachable Anchor

The seat belt for the rear center seat is located in the ceiling.

1. Pull out the seat belt's small latch plate and the latch plate from each holding slot in the ceiling.
2. Line up the triangle marks on the small latch plate and anchor buckle. Make sure the seat belt is not twisted. Attach the belt to the anchor buckle.
3. Insert the latch plate into the buckle. Properly fasten the seat belt the same way you fasten the lap/shoulder seat belt.

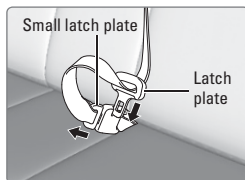
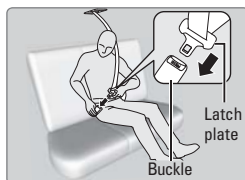
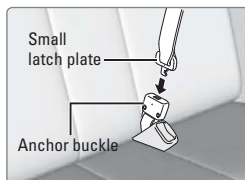
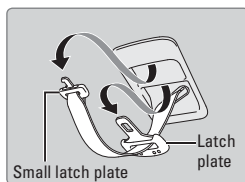

To unlatch the detachable anchor, insert the latch plate into the slot on the side of the anchor buckle.

### ⚠ WARNING

Using the seat belt with the detachable anchor unlatched increases the chance of serious injury or death in a crash.

Before using the seat belt, make sure the detachable anchor is correctly latched.

## Airbags

Your vehicle is equipped with three types of airbags: front airbags, side airbags, and side curtain airbags.

### ■ Front Airbags (SRS)

The front SRS airbags inflate in a moderate-to-severe frontal collision to help protect the head and chest of the driver and/or front passenger. They are housed in the center of the steering wheel for the driver, and in the dashboard for the front passenger. Both airbags are marked **SRS AIRBAG**.

SRS (Supplemental Restraint System) indicates that the airbags are designed to supplement seat belts, not replace them. Seat belts are the occupant's primary restraint system.

### ■ Advanced Airbags

Your front airbags have advanced features to help reduce the likelihood of airbag-related injuries to smaller occupants.

The driver's advanced front airbag system includes a seat position sensor. If the seat is too far forward, the airbag inflates with less force, regardless of the severity of the impact.

If there is a problem with the driver's seat position sensor, the SRS indicator will come on and the airbag will inflate with full (normal) force, regardless of the driver's seating position.

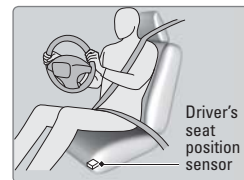

The passenger's advanced front airbag system has weight sensors. Although Honda recommends against carrying an infant or small child in front, if the sensors detect the weight of a child (up to 65 lbs or 29 kg), the system will automatically turn off the passenger's front airbag.

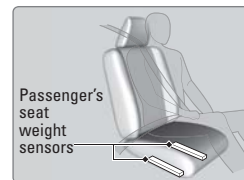

For both advanced front airbags to work properly:

- Do not spill any liquid on or under the seats.
- Do not put any object under the passenger's seat.
- Make sure any objects are positioned properly on the floor. Improperly positioned objects can interfere with the advanced airbag sensors.
- All occupants should sit upright and wear their seat belts properly.
- Do not place any cover over any part of the passenger side dashboard.

## ■ Side Airbags

The side airbags help protect the upper torso and pelvis of the driver or a front passenger during a moderate-to-severe side impact. They are housed in the outside edge of the driver's and front passenger's seat-backs. Both are marked **SIDE AIRBAG**.

## ■ Side Curtain Airbags

Side curtain airbags help protect the head and torso of the driver and passengers in outer seating positions during a moderate-to-severe side impact. The side curtain airbags equipped in this vehicle are also designed to help reduce the likelihood of partial and complete ejection of vehicle occupants through side windows in crashes, particularly rollover crashes.

The side curtain airbags are located in the ceiling above the side windows on both sides of the vehicle.

The side curtain airbags are designed to deploy in a rollover or moderate-to-severe side impact. If the SRS control unit senses that your vehicle is about to roll over, it immediately deploys both side curtain airbags and activates both front seat belt tensioners. If the impact is on the passenger's side, the passenger's side curtain airbag will inflate even if there are no occupants on that side of the vehicle.

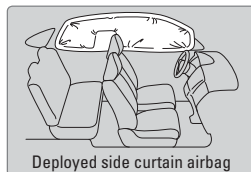
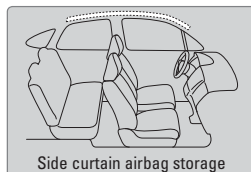

To get the best protection from the side curtain airbags, occupants should wear their seat belts properly and sit upright and well back in their seats.

Do not attach any objects to the side windows or roof pillars, as they can interfere with the proper operation of the side curtain airbags.

### When side curtain airbags deploy in a frontal collision

One or both side curtain airbags may inflate in a moderate-to-severe angled frontal collision. In this case, the side curtain airbags will deploy slightly after the front airbags.

## ■ Important Facts About Your Airbags

Always wear your seat belt properly, and sit upright and as far back from the steering wheel as possible while allowing full control of the vehicle. A front passenger should move their seat as far back from the dashboard as possible.

**Do not place hard or sharp objects between yourself and a front airbag.** Carrying hard or sharp objects on your lap, or driving with a pipe or other sharp object in your mouth, can result in injuries if your front airbag inflates.

**Do not attach or place objects on the front airbag covers.** Objects on the covers marked **SRS AIRBAG** could interfere with the proper operation of the airbags or be propelled inside the vehicle and hurt someone if the airbags inflate.

**Do not attach accessories on or near the side airbags.** They can interfere with the proper operation of the airbags, or hurt someone if an airbag inflates.

**Do not attach any objects to the side windows or roof pillars.** They can interfere with the proper operation of the side curtain airbags.

**Do not cover or replace the front seat-back covers.** This can prevent your side airbags from properly deploying during a side impact.

### ⚠ WARNING

An open glove box can cause serious injury to your passenger in a crash, even if the passenger is wearing the seat belt.

Always keep the glove box closed while driving.

## ■ Airbag System Indicators

If a problem occurs in the airbag system, the SRS indicator comes on and a message appears on the multi-information display\*.

### SRS (Supplemental Restraint System) Indicator

If the indicator comes on at any other time besides vehicle start-up, or does not come on at all, have the system checked by a dealer as soon as possible. If you don't, your airbags and seat belt tensioners may not work properly when they are needed.

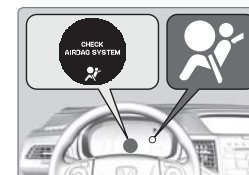

### ⚠ WARNING

Ignoring the SRS indicator can result in serious injury or death if the airbag systems or tensioners do not work properly.

Have your vehicle checked by a dealer as soon as possible if the SRS indicator alerts you to a possible problem.

\*if equipped

### Passenger Airbag Off Indicator

The indicator comes on to alert you that the front passenger's front airbag has been turned off. This occurs when the front passenger's weight sensors detect 65 lbs (29 kg) or less, the weight of an infant or small child, on the seat.



Infants and small children should always ride properly restrained in a back seat.

Objects placed on the seat can also cause the indicator to come on.

If the front passenger's seat is empty, the passenger's front airbag will not deploy and the indicator will not come on.

If the indicator comes on with no occupant or objects in the front passenger's seat, something may be interfering with the weight sensors, such as:

- An object hanging on the seat or in the seat-back pocket.
- A child seat or other object pressing against the rear of the seat-back.
- A rear passenger pushing or pulling on the back of the front passenger's seat.
- The front seat or seat-back is forced against an object on the seat or floor behind it.
- An object placed under the front passenger's seat.

If none of these conditions exist, have your vehicle checked by a dealer as soon as possible.

The passenger airbag off indicator may go on and off repeatedly if the total weight on the seat is near the airbag cutoff threshold.

### Airbag System Components

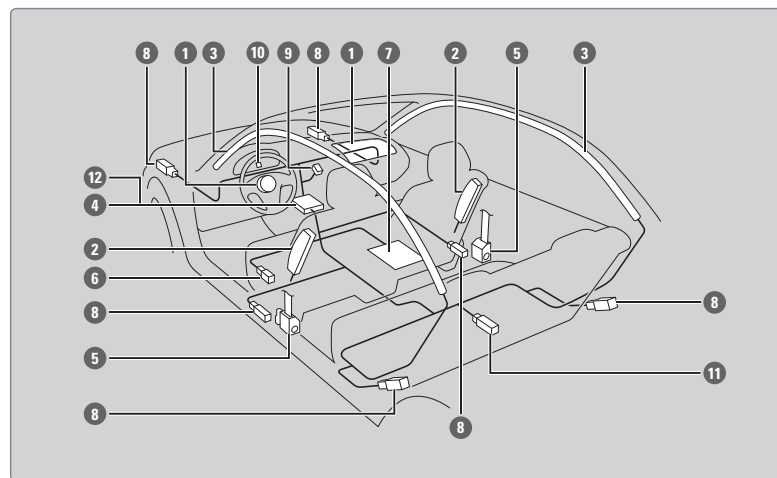

- 1 Two SRS (Supplemental Restraint System) front airbags. The driver's airbag is stored in the center of the steering wheel; the front passenger's airbag is stored in the dashboard. Both are marked **SRS AIRBAG**.
- 2 Two side airbags, one for the driver and one for the front passenger. The airbags are stored in the outer edges of the seat-backs. Both are marked **SIDE AIRBAG**.
- 3 Two side curtain airbags, one for each side of the vehicle. The airbags are stored in the ceiling, above the side windows. The front and rear pillars are marked **SIDE CURTAIN AIRBAG**.
- 4 An electronic control unit that continually monitors and can record information about the sensors, the airbag activators, the seat belt tensioners, and driver and front passenger seat belt use when the vehicle is on.
- 5 Automatic front seat belt tensioners. The driver's and front passenger's seat belts incorporate sensors that detect whether or not they are fastened.
- 6 A driver's seat position sensor. If the seat is too far forward, the airbag will inflate with less force.
- 7 Weight sensors in the front passenger's seat. The front passenger's airbag will be turned off if the weight on the seat is 65 lbs (29 kg) or less (the weight of an infant or small child).
- 8 Impact sensors that can detect a moderate-to-severe front or side impact.
- 9 An indicator on the dashboard that alerts you that the front passenger's front airbag has been turned off.
- 10 An indicator on the instrument panel that alerts you to a possible problem with the airbag system or seat belt tensioners.
- 11 Safing sensor
- 12 A rollover sensor that detects whether the vehicle is about to roll over.



## ■ Airbag Care

You do not need to, and should not, perform any maintenance on or replace any airbag system components yourself. However, you should have your vehicle inspected by a dealer in the following situations:

### When the airbags have deployed

If an airbag has inflated, the control unit and other related parts must be replaced. Similarly, once an automatic seat belt tensioner has been activated, it must be replaced.

### When the vehicle has been in a moderate-to-severe collision

Even if the airbags did not inflate, have your dealer inspect the following: the driver's seat position sensor, weight sensors in the passenger's seat, front seat belt tensioners, and each seat belt that was worn during the crash.

### Do not remove or modify a front seat without first consulting a dealer

This would likely disable the driver's seat position sensor or the weight sensors in the passenger's seat. If it is necessary to remove or modify a front seat to accommodate a person with disabilities, contact a Honda dealer. For U.S. vehicles, call Honda Automobile Customer Service at (800) 999-1009. For Canadian vehicles, call Honda Canada Customer Relations at (888) 946-6329.

## Child Safety

Each year, many children are injured or killed in vehicle crashes because they are either unrestrained or not properly restrained. In fact, vehicle collisions are the number one cause of death of children ages 12 and under.

The National Highway Traffic Safety Administration and Transport Canada recommend that all children ages 12 and under be properly restrained in a rear seat. Some states or provinces/territories have laws restricting where children may ride.

To reduce the number of child deaths and injuries, every state, Canadian province and territory requires that infants and children be properly restrained when they ride in a vehicle.

## ■ Protecting Child Passengers

- An inflating front or side airbag can injure or kill a child sitting in the front seat.
- A child in the front seat is more likely to interfere with the driver's ability to safely control the vehicle.
- Statistics show that children of all sizes and ages are safer when they are properly restrained in a rear seat.
- Any child who is too small to wear a seat belt correctly must be restrained in an approved child seat that is properly secured to the vehicle using either the lap belt portion of the lap/shoulder belt or the lower anchors of the LATCH system.
- Never hold a child on your lap because it is impossible to protect them in the event of a collision.
- Never put a seat belt over yourself and a child. During a crash, the belt would likely press deep into the child and cause serious or fatal injuries.
- Never let two children use the same seat belt. Both children could be very seriously injured in a crash.
- Do not allow children to operate the doors, windows, or seat adjusters.
- Do not leave children in the vehicle unattended, especially in hot weather when the inside of the vehicle can get hot enough to kill them. They could also activate vehicle controls, causing it to move unexpectedly.

### WARNING

Children who are unrestrained or improperly restrained can be seriously injured or killed in a crash.

Any child too small for a seat belt should be properly restrained in a child seat. A larger child should be properly restrained with a seat belt, using a booster seat if necessary.

**⚠️ WARNING**

Allowing a child to play with a seat belt or wrap one around their neck can result in serious injury or death.

Instruct children not to play with any seat belt and make sure any unused seat belt a child can reach is buckled, fully retracted, and locked.

**■ Protecting Infants**

An infant must be properly restrained in a rear-facing, reclining child seat until the infant reaches the seat maker's weight or height limit for the seat, and the infant is at least one year old. Many experts recommend use of a rear-facing seat for a child up to two years old if the child's height and weight are appropriate for a rear-facing seat.

Child seats must be placed and secured in a rear seating position. Rear-facing child seats should never be installed in a forward-facing position.

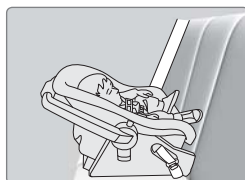

When properly installed, a rear-facing child seat may prevent the driver or a front passenger from moving their seat all the way back, or from locking their seat-back in the desired position. If this occurs, we recommend that you install the child seat directly behind the front passenger's seat, move the seat as far forward as needed, and leave it unoccupied. Or, you may wish to get a smaller rear-facing child seat.

**⚠️ WARNING**

Placing a rear-facing child seat in the front seat can result in serious injury or death during a crash.

Always place a rear-facing child seat in the rear seat, not the front.

**■ Protecting Smaller Children**

If a child is at least one year old and within the weight range indicated by the child seat manufacturer, the child should be properly restrained in a firmly secured forward-facing child seat.

We strongly recommend placing a forward-facing child seat in a rear seating position.

Placing a forward-facing child seat in the front seat can be hazardous, even with advanced front airbags that automatically turn the passenger's front airbag off. A rear seat is the safest place for a child.

**⚠️ WARNING**

Placing a forward-facing child seat in the front seat can result in serious injury or death if the front airbag inflates.

If you must place a forward-facing child seat in front, move the vehicle seat as far back as possible, and properly restrain the child.

**■ Selecting a Child Seat**

Most child seats are LATCH-compatible (Lower Anchors and Tethers for Children). Some have a rigid-type connector, while others have a flexible-type connector. Both are equally easy to use. Some existing and previously owned child seats can only be installed using the seat belt. Whichever type you choose, follow the child seat manufacturer's use and care instructions as well as the instructions in this manual. Proper installation is key to maximizing your child's safety.

In seating positions and vehicles not equipped with LATCH, a LATCH-compatible child seat can be installed using the seat belt and a top tether for added security. This is because all child seats are required to be designed so that they can be secured with a lap belt or the lap part of a lap/shoulder belt. In addition, the child seat manufacturer may advise that a seat belt be used to attach a LATCH-compatible seat once a child reaches a specified weight. Please read the child seat owner's manual for proper installation instructions.

**Important considerations when selecting a child seat**

Make sure the child seat meets the following three requirements:

- The child seat is the correct type and size for the child.
- The child seat is the correct type for the seating position.
- The child seat is compliant with Federal Motor Vehicle Safety Standard 213 or Canadian Motor Vehicle Safety Standard 213.

### ■ Installing a LATCH-Compatible Child Seat

A LATCH-compatible child seat can be installed in each of the rear seats. A child seat is attached to the lower anchors with either the rigid or flexible type of connectors.

1. Locate the lower anchors under the marks.
2. Place the child seat on the vehicle seat, then attach the child seat to the lower anchors according to the instructions that came with the child seat. Make sure that the lower anchors are not obstructed by the seat belt or any other object.

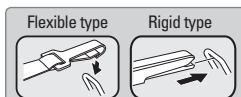
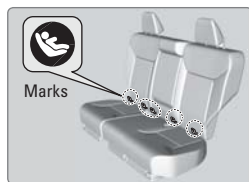

3. **For outer seats:** Raise the head restraint to its highest position, then route the tether strap between the head restraint legs.

**For the center seat:** Lower the head restraint to its lowest position. Open the anchor cover. Route the tether strap over the head restraint.

Make sure the strap is not twisted. Secure the tether strap hook onto the anchor.

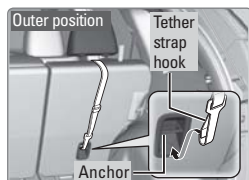

4. Tighten the tether strap according to the seat maker's instructions.

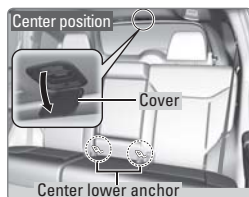

5. Make sure the child seat is firmly secured by rocking it forward and back and side to side; little movement should be felt.

6. Make sure any unused seat belt that a child can reach is buckled, the lockable retractor is activated, and the belt is fully retracted and locked.

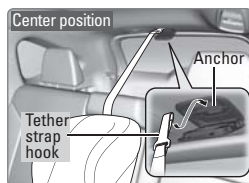

### ■ Installing a Child Seat with a Lap/Shoulder Seat Belt

1. Place the child seat on the vehicle seat.
2. Route the seat belt through the child seat according to the seat maker's instructions, and insert the latch plate into the buckle. Insert the latch plate fully until it clicks.
3. Slowly pull the shoulder part of the belt all the way out until it stops. This activates the lockable retractor.
4. Let the seat belt completely wind up into the retractor, then try to pull it out to make sure the retractor is locked. If you are able to pull the shoulder belt out, the lockable retractor is not activated. Pull the seat belt all the way out, and repeat steps 3 – 4.
5. Grab the shoulder part of the seat belt near the buckle, and pull up to remove any slack from the lap part of the belt. When doing this, place your weight on the child seat and push it into the vehicle seat.
6. Make sure the child seat is firmly secured by rocking it forward and back and side to side; little movement should be felt.
7. Make sure any unused seat belt that a child can reach is buckled, the lockable retractor is activated, and the belt is fully retracted and locked.

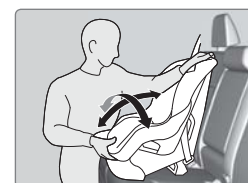

To deactivate a lockable retractor, release the buckle and allow the seat belt to wind up all the way.

### ■ Adding Security with a Tether

Two tether anchorage points are provided behind the rear outer seating positions and one in the ceiling for the rear center. A child seat that is installed with a seat belt and comes with a tether can use the tether for additional security.

1. **Using an outer anchor:** Raise the head restraint to its highest position, then route the tether strap through the head restraint legs.

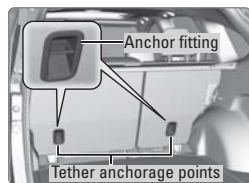

**Using the center anchor:** Lower the head restraint to its lowest position. Open the anchor cover. Route the tether strap through the head restraint legs.

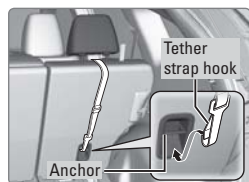

Make sure the strap is not twisted. Secure the tether strap hook onto the anchor.

2. Secure the tether strap hook onto the anchor.

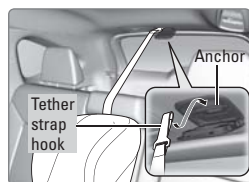

3. Tighten the tether strap according to the seat maker's instructions.

### ■ Protecting Larger Children

When a child is too big for a child seat, secure the child in a rear seat using the lap/shoulder seat belt.

Have the child sit upright and all the way back, then ensure the following:

- The child's knees bend comfortably over the edge of the seat.
- The shoulder belt crosses between the child's neck and arm.
- The lap part of the seat belt is as low as possible, touching the child's thighs.
- The child can stay seated for the whole trip.



If a lap/shoulder belt cannot be used properly, position the child in a booster seat in a rear seating position. For the child's safety, check that the child meets the booster seat manufacturer's recommendations.

Some U.S. states and Canadian provinces/territories require children to use a booster seat until they reach a given age or weight (e.g., 6 years or 60 lbs). Be sure to check current laws in the state or province/territory where you intend to drive.

#### **⚠ WARNING**

Allowing a child age 12 or under to sit in the front can result in injury or death if the passenger's front airbag inflates.

If a larger child must ride in front, move the vehicle seat as far to the rear as possible, then have the child sit up properly and wear the seat belt properly, using a booster seat if needed.

## Safety Label Locations

Safety labels are in the locations shown. They warn you of potential hazards that can cause serious injury or death. Read these labels carefully.

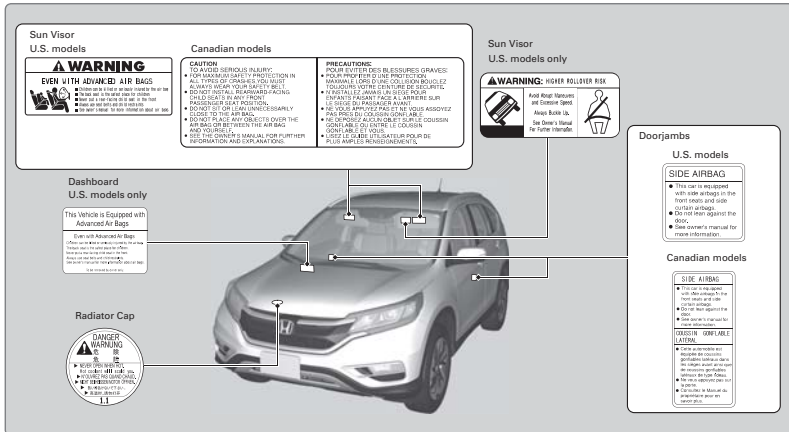

## Reporting Safety Defects

### In the U.S.

If you believe that your vehicle has a defect which could cause a crash or could cause injury or death, you should immediately inform the National Highway Traffic Safety Administration (NHTSA) in addition to notifying American Honda Motor Co., Inc.

If NHTSA receives similar complaints, it may open an investigation, and if it finds that a safety defect exists in a group of vehicles, it may order a recall and remedy campaign. However, NHTSA cannot become involved in individual problems between you, your dealer, or American Honda Motor Co., Inc.

To contact NHTSA, you may call the Vehicle Safety Hotline toll-free at 1-888-327-4236 (TTY: 1-800-424-9153); go to <http://www.safercar.gov>; or write to: Administrator, NHTSA, 1200 New Jersey Avenue, SE., Washington, DC 20590. You can also obtain other information about motor vehicle safety from <http://www.safercar.gov>.

### In Canada

If you believe that your vehicle has a defect which could cause a crash or could cause injury or death, you should immediately inform Honda Canada, Inc., and you may also inform Transport Canada.

If Transport Canada receives similar complaints, it may open an investigation, and if it finds that a safety defect exists in a group of vehicles, it may lead to a recall and remedy campaign. However, Transport Canada cannot become involved in individual problems between you, your dealer, or Honda Canada, Inc.

To contact Transport Canada's Defect Investigations and Recalls Division, you may call 1-800-333-0510. For more information on reporting safety defects or about motor vehicle safety, go to <http://www.tc.gc.ca/roadsafety>.

# INSTRUMENT PANEL

Learn about the indicators, gauges, and displays related to driving the vehicle.



Indicators briefly appear with each engine start and then go out. Red and amber indicators are most critical. Blue and green indicators are used for general information.

## Malfunction Indicators

These are the most critical indicators. If they come on and stay lit while driving or at any other time, there may be a problem. See your dealer if necessary.

### Brake system

- Brake fluid is low.
- The brake system has a problem.

Press the brake pedal lightly to check pedal pressure. If normal, check the brake fluid level when you stop. If abnormal, take immediate action. If necessary, downshift the transmission to slow the vehicle using engine braking. Have your vehicle repaired immediately.

### Low oil pressure

Engine oil pressure is low. Stop in a safe place. Open the hood. Check the oil level, and add oil if necessary (see page 127). If the indicator does not turn off, have your vehicle repaired immediately.

### Charging system

The battery is not charging. Turn off all electrical items, but do not turn off the vehicle to prevent further battery discharge. Have your vehicle repaired immediately.

### Supplemental Restraint System (SRS)

There is a problem with one of the airbag systems or seat belt tensioners.

*\*if equipped*

### Smart Entry system\*

There is a problem with the smart entry system.

### Malfunction indicator lamp (check engine light)

- The emissions control system may have a problem, or the fuel cap is loose or missing.
- (Blinks) A misfire in the engine's cylinders is detected. Stop in a safe place, and wait for the engine to cool down.

### Anti-lock Brake System (ABS)

There is a problem with the anti-lock brake system. Your vehicle still has normal braking ability, but no anti-lock function.

### Tire Pressure Monitoring System (TPMS)\*

There is a problem with the tire pressure monitoring system, or the vehicle is fitted with the compact spare tire.

### Collision Mitigation Braking System™ (CMBS™)\*

There is a problem with CMBS.

### Lane Departure Warning (LDW)\*

There is a problem with the LDW system.

### Lane Keeping Assist System (LKAS)\*

There is a problem with the LKAS.

### Vehicle Stability Assist (VSA®)

There is a problem with the VSA system or hill start assist system.

### Adaptive Cruise Control (ACC)\*

There is a problem with the ACC system.

### Electric Power Steering (EPS)

There is a problem with the EPS system. Stop in a safe place, and restart the vehicle.

### Starter system\*

There is a problem with the starter system.

### All Wheel Drive (AWD)\*

There is a problem with the AWD system. If the indicator blinks, the system is overheated and inactive. Stop in a safe place, and idle until the indicator goes off.

### Brake system

There is a problem with one of the braking systems. Your vehicle still has normal braking ability.





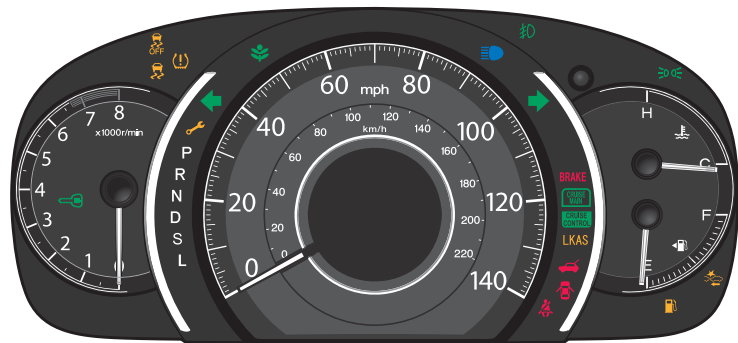

*\*if equipped*





### Condition Indicators

These indicators may require you to perform an action.

- 
**Parking brake**  
 Release the parking brake before driving. You will hear a beep if you drive with it not fully released.
- 
**Seat belt reminder**  
 Make sure seat belts are fastened for you and all passengers. The indicator blinks and beeps sound continuously if you or your front passenger has not fastened your seat belts when you begin driving. If the indicator remains on after seat belts are fastened, see your dealer.
- 
**Door/tailgate open\***  
 A door or the tailgate is open.
- 
**Tailgate open\***  
 The tailgate is open.
- 
**Low fuel**  
 Refuel as soon as possible. If the indicator blinks, there is a problem with the fuel gauge. See your dealer.
- 
**Low tire pressure**  
 Stop in a safe place, check tire pressures, and inflate tire(s) if necessary. If the indicator remains on after tire inflation, you need to calibrate the system (see page 115). The indicator also appears if your vehicle is fitted with the compact spare tire. Have your regular tire repaired or replaced as soon as possible.
- 
**Vehicle Stability Assist (VSA®)**  
 (Blinks) VSA is active.

\*if equipped

- 
**Maintenance Minder™\***  
 Scheduled maintenance for your vehicle is due.

- 
**Immobilizer**  
 Your key or remote transmitter cannot be recognized by the vehicle. If the indicator blinks, you may not be able to start the engine. Turn the vehicle off, and then on again. If it continues to blink, there may be a problem with the system. See your dealer.

### On/Off Indicators

These indicators remind you when an item is on or off.

- |  |  |
|--|--|
|  VSA off                  |  High beams on      |
|  CRUISE MAIN* on          |  Exterior lights on |
|  CRUISE CONTROL* on       |  ECON mode on       |
|  Turn signals/ hazards on |  LKAS LKAS* off     |
|  Fog lights* on           |  CMBS* off          |

\*if equipped

### Information Display\*

Consists of several displays that provide you with useful information.

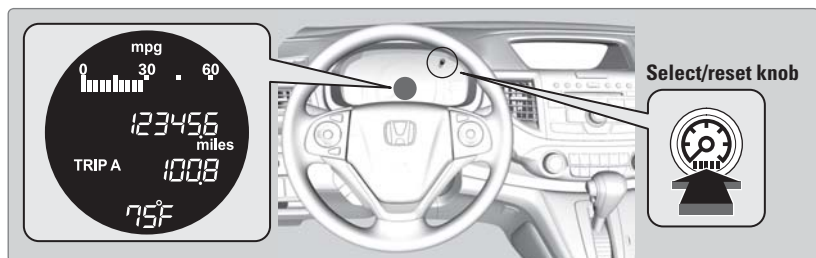

Press the select/reset knob to change displays.

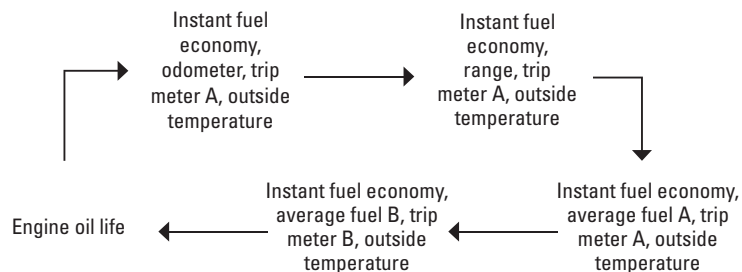

### Multi-Information Display (MID)\*

Consists of several displays that provide you with useful information.

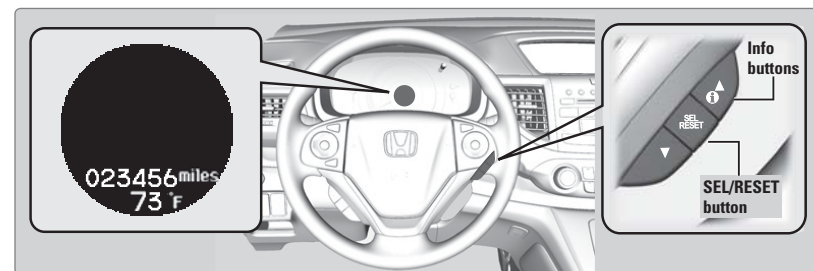

#### Main Displays

Press the Info buttons to change main displays.

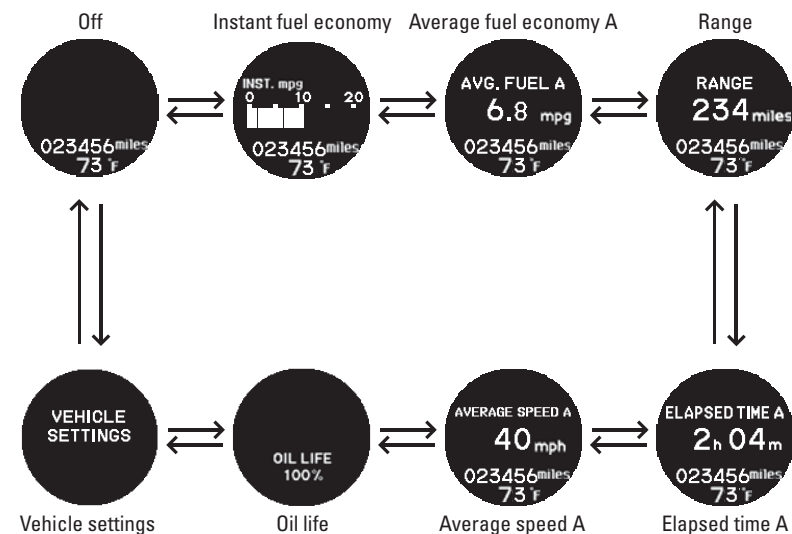

#### Lower Displays

Press the SEL/RESET button to change lower displays.

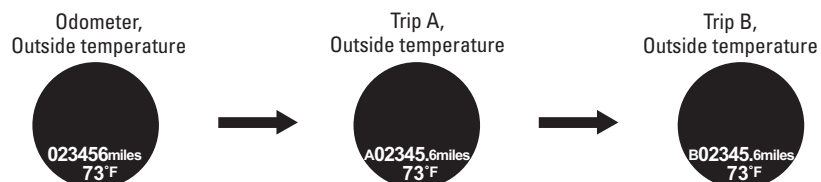

\*if equipped

\*if equipped

## ■ Changing Settings Using the MID

Use the Info and SEL/RESET buttons to operate the Vehicle Settings menu in the MID. The vehicle must be in Park (P) to enter the menu.

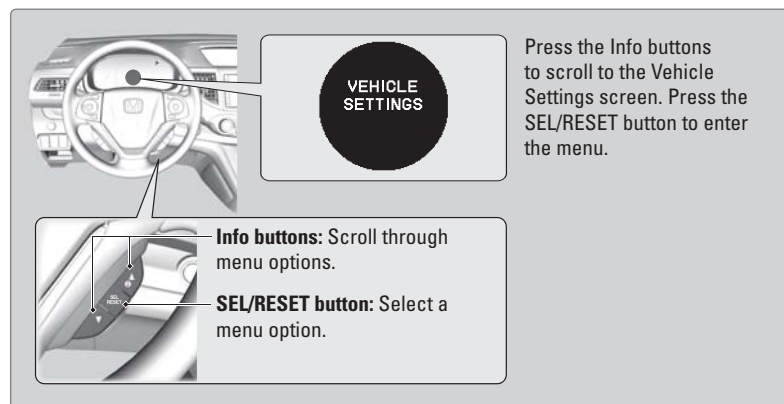

## Customized Features

Use the Vehicle Menu in the i-MID to customize certain features, such as the display, the trip computer, and door locking/unlocking. Use the steering wheel controls to make and enter selections when the vehicle is stopped.

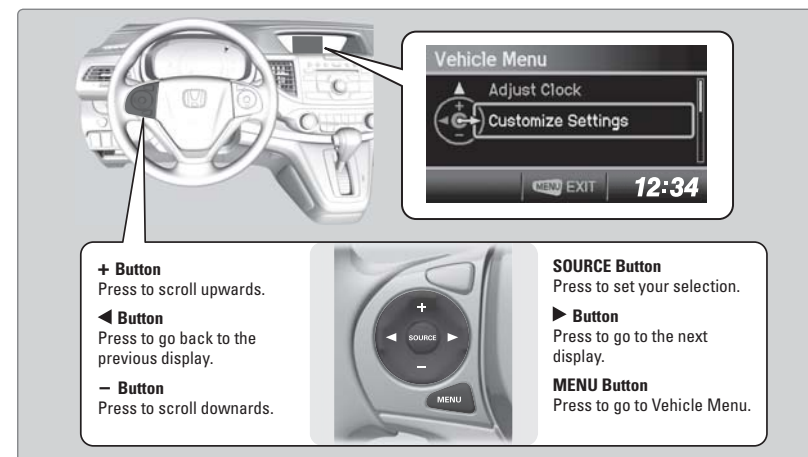

## ■ Changing Settings Using the Touchscreen\*

Select items on the touchscreen to make selections.

1. Select SETTINGS.
2. Select an option (Clock/Info, Audio, Bluetooth, Phone, Camera, System, or Navi\*).
3. Select a setting option, and make your preferred changes.
4. Press BACK to exit the menus.

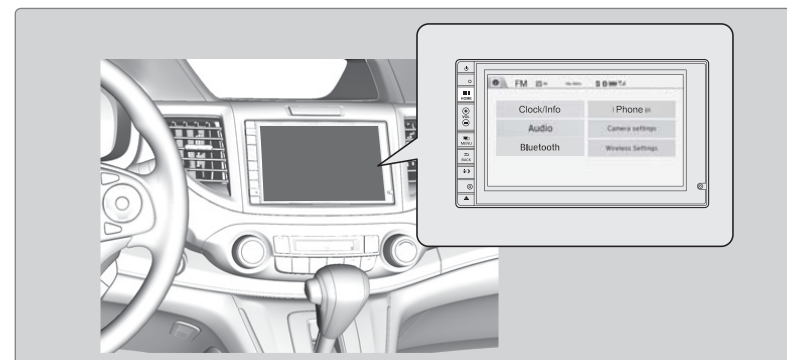

\*if equipped

# VEHICLE CONTROLS

Learn about the various controls necessary for operating and driving the vehicle.

## Using the Key or Remote Transmitter

Lock or unlock the doors and tailgate.

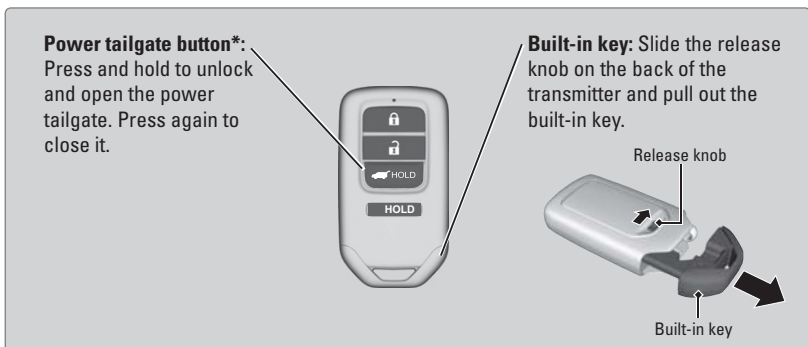
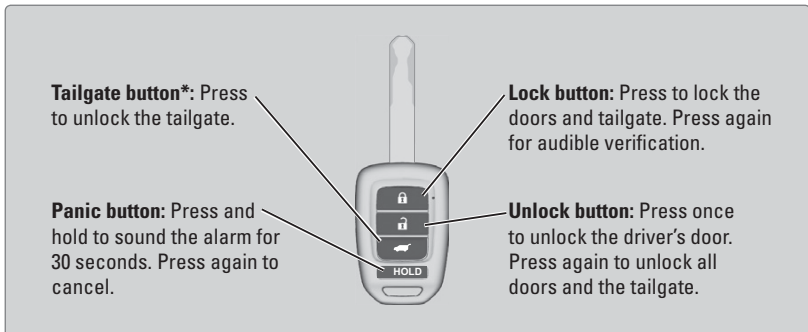

### NOTICE

Leaving the key or remote transmitter in the vehicle can result in theft or accidental movement of the vehicle. Always take it with you whenever you leave the vehicle unattended.

\*if equipped

## Smart Entry System\*

When you carry the remote transmitter (for example, in a pocket or purse) and it is outside the vehicle and within range (about 32 inches or 80 cm), you can lock or unlock the doors and tailgate without handling the transmitter.

### ■ Unlocking/Locking the Doors

**To unlock**: Grab the driver's door handle when the vehicle is off to unlock the driver's door. Grab the front passenger's door handle to unlock all doors and the tailgate.



**To lock**: Press the door lock button on the front door handle when the vehicle is off. If the remote transmitter is inside the vehicle, the doors will not lock.

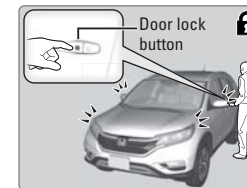

### ■ Unlocking/Locking the Tailgate

**To unlock**: Press the tailgate release button under the tailgate handle to unlock the tailgate. The vehicle can be on or off.

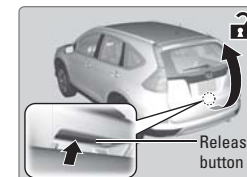

**To lock**: Press the tailgate lock button to lock the tailgate and all doors. If the remote transmitter is inside the vehicle, the tailgate and doors will not lock.

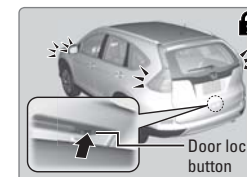

\*if equipped

## Door Operation

Use several methods to lock or unlock the doors.

### ■ Using the Lock Tab

**To unlock:** Pull the lock tab rearward. When you unlock the door using the lock tab on the driver's door, only the driver's door unlocks.

**To lock:** Push the lock tab forward. When you lock the door using the lock tab on the driver's door, all other doors and the tailgate lock.

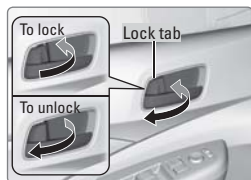

### ■ Using the Front Door Inner Handle

When you pull either front door inner handle, the door unlocks and opens.



### ■ Using the Master Door Lock Switch

**To unlock:** Press the unlock side of the switch to unlock all doors and the tailgate.

**To lock:** Press the lock side of the switch to lock all doors and the tailgate.

The front passenger's door also has the master door lock switch.

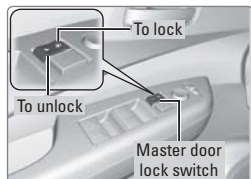

### ■ Childproof Door Locks

The childproof door locks prevent the rear doors from being opened from the inside, regardless of the position of the lock tab.

Slide the lever in the rear door to the lock position, and close the door.

Open the door using the outer door handle.

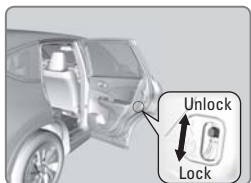

## Tailgate Operation\*

Use these methods to operate the tailgate.

### ■ Opening the Tailgate

Press the tailgate release button and lift up the tailgate to open it.

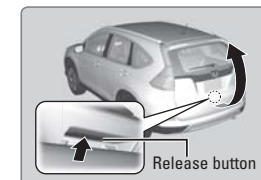

### ■ Closing the Tailgate

Grab the inner handle and pull the tailgate down. Push it closed from the outside.



## Power Tailgate Operation\*

Use these methods to operate the power tailgate.

### ■ Power Tailgate Button

The vehicle must be in Park (P) with all doors unlocked.

Press and hold the power tailgate button on the dashboard to open the tailgate. Press it again at any time to close it.

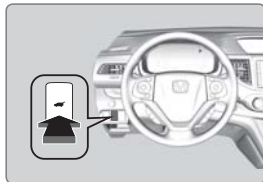

### ■ Power Tailgate Close Button

Press the power tailgate close button to automatically close the tailgate. Press it again at any time to reverse the tailgate direction.

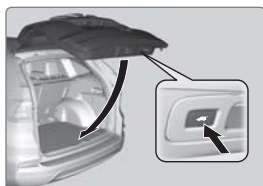

### ⚠ WARNING

Closing the power tailgate while anyone is in the path of the tailgate can cause serious injury.

Make sure everyone is away from the tailgate before closing it.

### NOTICE

Do not push or pull on the power tailgate when it is being automatically opened or closed. Forcibly opening or closing the power tailgate while in operation can deform the tailgate frame.

\*if equipped

## Power Window Operation

The power windows can be opened and closed when the vehicle is on by using the switches on the doors. The switches on the driver's side can be used to open and close all the windows.

### ■ Automatic Operation

**To open:** Push the switch down firmly.

**To close:** Pull the switch up firmly.

The window opens or closes completely. To stop the window at any time, push or pull the switch again briefly.

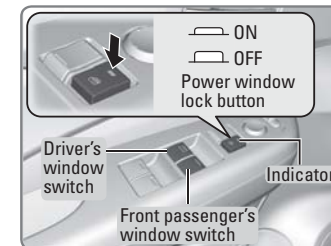

### ■ Manual Operation

**To open:** Push the switch down lightly.

**To close:** Pull the switch up lightly.

Release the switch when the windows reach the desired position.

### ■ Power Window Lock

Push in the power window lock button so only the driver's window can be operated. The driver can operate all other windows using the specific switches.

### ⚠ WARNING

Closing a power window on someone's hands or fingers can cause serious injury.

Make sure your passengers are away from the windows before closing them.



## Power Moonroof Operation\*

The moonroof can be opened and closed when the vehicle is on by using the switch on the ceiling.

### Automatic Operation

**To open:** Push the switch back firmly to the second detent, then release.

**To close:** Push the switch forward firmly to the second detent, then release.

The moonroof opens or closes completely. To stop the moonroof at any time, push the switch briefly.

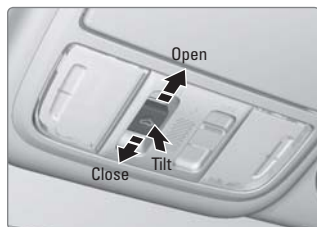

### Manual Operation

**To open:** Push and hold the switch back to the first detent until the desired position is reached.

**To close:** Push and hold the switch forward to the first detent until the desired position is reached.

### Moonroof Tilt

**To tilt:** Push the center of the switch.

**To close:** Push the switch forward firmly, then release.

### NOTICE

Opening the moonroof in below freezing temperatures or when it is covered with snow or ice can damage the moonroof panel or motor.

### WARNING

Closing the moonroof on someone's hands or fingers can cause serious injury.

Make sure your passengers are away from the moonroof before closing it.

\*if equipped

## Interior and Exterior Lights

Operate interior and exterior lights when the vehicle is on or off.

### Brightness Control

Adjust instrument panel brightness when the vehicle is on.

**To brighten:** Turn the knob to the right.

**To dim:** Turn the knob to the left.

A beep sounds when the brightness reaches minimum or maximum.



### Interior Lights

Change the interior light settings using the switch on the ceiling.

**ON position:** Interior lights remain on.

**Door-activated position:** Interior lights come on when any of the doors are opened, the driver's door is unlocked, or the vehicle is turned off.

**OFF position:** Interior lights remain off.



### Map Lights

Press the front map lights to turn on or off.



### Cargo Area Lights

Located on the rear ceiling in front of the tailgate.

**ON position:** Cargo lights remain on.

**Door-activated position:** Cargo area lights are on when the tailgate is open.

**OFF position:** Cargo area lights remain off.



**Exterior Lights**

Rotate the switches on the headlight lever to operate the exterior lights. Push the lever forward to turn on the high beams. Return the lever to its original position for low beams.

**OFF:** All exterior lights are off.

Turn on exterior lights except headlights.

**AUTO:** Turn on the automatic lighting feature\*. Headlights turn on or off depending on ambient brightness when the vehicle is on. Headlights automatically come on after the wipers are engaged for a certain time.

Turn on all exterior lights including headlights.

Turn fog lights\* on or off.

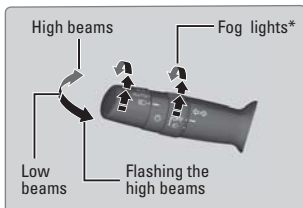

**One-Touch Turn Signal**

Use this quick and convenient method to signal a lane change.

Lightly push the turn signal lever up or down for a three-blink sequence.

For a continuous signal, push the lever up or down until it locks into place.

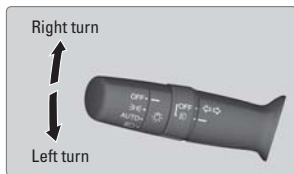

*\*if equipped*

**Wiper Operation**

The windshield wipers and washers can be used when the vehicle is on.

**Front Wipers**

Move the wiper lever up or down to the desired position.

**Headlight-Wiper Integration\***

When the headlights are in the AUTO position, they automatically turn on when the front wipers operate several times within a certain interval. The headlights turn off shortly after the wipers are turned off, or if there is enough ambient light.

**Intermittent or Automatic Wipers\***

When you move the lever to the INT or AUTO position, the wipers operate based on the wiper delay.

Adjust the wiper delay using the adjustment ring.

**Rear Wiper**

When you shift to Reverse (R) and the front wipers are activated, the rear wiper activates even if the switch is off.

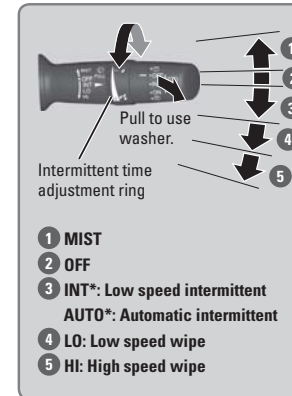

**NOTICE**

Do not use the wipers when the windshield is dry. The windshield will get scratched, or the rubber blades will get damaged.

In cold weather, the blades may freeze to the windshield, becoming stuck. Operating the wipers in this condition may damage the wipers. Use the defroster or heated windshield button\* to warm the windshield, or manually clear the windshield of ice and snow before turning on the wipers.

*\*if equipped*

## Adjusting the Seats

Make seat adjustments before driving to ensure the best comfort and safety.

### Adjusting the Front Seats

Adjust the driver's seat as far back as possible while allowing you to maintain full control of the vehicle. You should be able to sit upright and well back in the seat, adequately press the pedals without leaning forward, and grip the steering wheel comfortably. The passenger's seat should be adjusted so that it is as far back from the front airbag in the dashboard as possible.

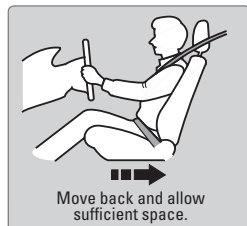

The National Highway Traffic Safety Administration and Transport Canada recommend that drivers allow at least 10 inches (25 cm) between the center of the steering wheel and the chest.

### Driver's power seat\*

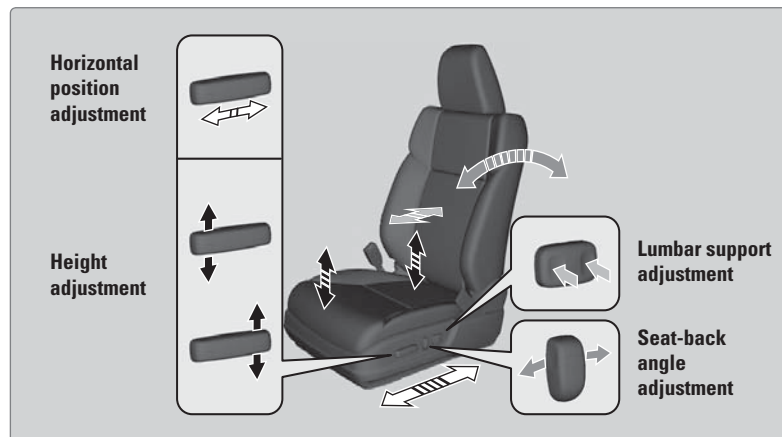

\*if equipped

### Manual seats\*

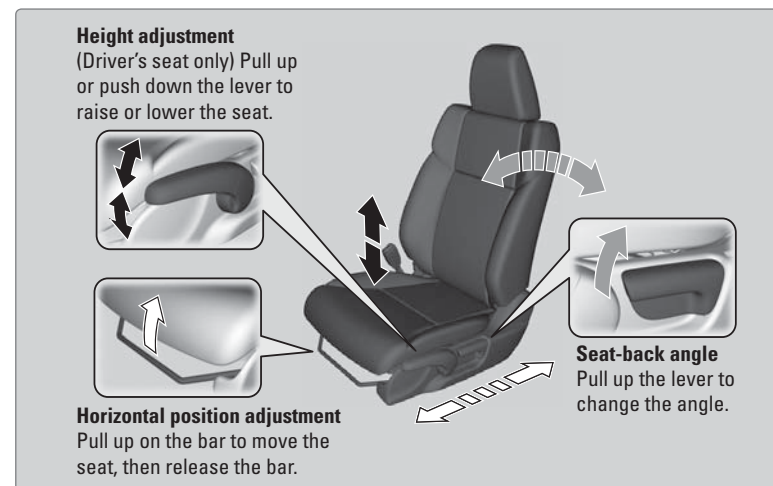

**⚠ WARNING**  
 Reclining the seat-back too far can result in serious injury or death in a crash. Adjust the seat-back to an upright position, and sit well back in the seat.

**⚠ WARNING**  
 Sitting too close to a front airbag can result in serious injury or death if the front airbags inflate. Always sit as far back from the front airbags as possible while maintaining control of the vehicle.

**⚠ WARNING**  
 Sitting improperly or out of position can result in serious injury or death in a crash. Always sit upright, well back in the seat, with your feet on the floor.

\*if equipped

TABLE OF CONTENTS  
 VISUAL INDEX  
 SAFETY INFORMATION  
 INSTRUMENT PANEL  
 VEHICLE CONTROLS  
 AUDIO AND CONNECTIVITY  
 BLUETOOTH® HANDSFREELINK®  
 HONDALINK®

NAVIGATION  
 DRIVING  
 HANDLING THE UNEXPECTED  
 MAINTENANCE  
 SPECIFICATIONS  
 CUSTOMER INFORMATION  
 VOICE COMMAND INDEX  
 INDEX

## ■ Adjusting the Head Restraints

Your vehicle is equipped with head restraints in all seating positions. Head restraints are most effective for protection against whiplash and other rear-impact crash injuries.

The center of the back of the occupant's head should rest against the center of the restraint. The tops of the occupant's ears should be level with the center height of the restraint.

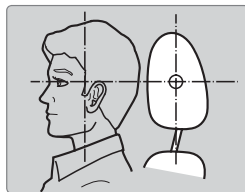

### Front and rear center seat head restraints

**To raise the head restraint:** Pull it upward.

**To lower the head restraint:** Push it down while pressing the release button.

**To remove the head restraint:** Pull the restraint up as far as it will go. Then push the release button, and pull the restraint up and out.

**To reinstall a head restraint:** Insert the legs back in place, then adjust the head restraint to an appropriate height while pressing the release button. Pull up on the restraint to make sure it is locked in position.

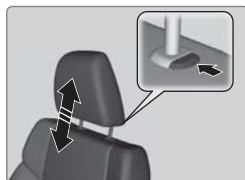

### Rear outer seat head restraints

**To fold down the head restraint:** Pull up on the strap.

**To return the head restraint to its upright position:** Pull up the head restraint and push it back until it latches into place.

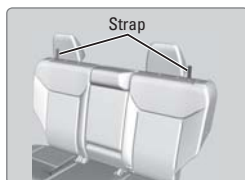

In order for the head restraint system to work properly:

- Do not hang any items on the head restraints, or from the restraint legs.
- Do not place any object between an occupant and the seat-back.
- Install each restraint in its proper location.

## ⚠ WARNING

Improperly positioning head restraints reduces their effectiveness and increases the likelihood of serious injury in a crash.

Make sure head restraints are in place and positioned properly before driving.

## ⚠ WARNING

Failure to reinstall, or correctly reinstall, the head restraints can result in severe injury during a crash.

Always replace the head restraints before driving.

## ■ Floor Mats

Position the front seat floor mats properly, and anchor them. If they are not properly positioned, the floor mats can interfere with the front seat functions.

**Do not put additional floor mats on top of the anchored mats.**

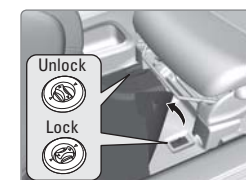

## Rear Seats

Fold down rear seats to allow for additional storage space.

### Folding Down Rear Seats

1. Store the center seat belt. Insert the latch plate into the slot on the side of the anchor buckle. Retract the seat belt into the holder on the ceiling (see page 8).
2. Lower the center head restraint to its lowest position. Put the armrest back into the seat-back.
3. **From the rear door side:** Pull the release strap.  
**From the cargo area side:** Pull the release lever.

Make sure all items in the cargo area or items extending to the rear seats are properly secured. Loose items can fly forward if you have to brake hard.

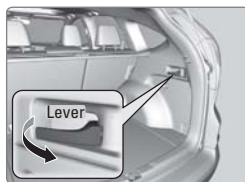

### Returning Seats to the Upright Position

1. Pull the seat-back up and push back into place until you hear a click.
2. Push the head restraint up to its original position.
3. Pull the seat cushion up and push it down into its original position.



## Driving Position Memory System\*

You can store two driver's seat positions into memory when the vehicle is on using the buttons on the driver's door.

1. Adjust the seat to your preferred position.
2. Press SET.
3. Press and hold memory button 1 or 2. You will hear two beeps when the memory is set.
4. Press one of the memory buttons to recall previously stored positions.  
Lumbar positions cannot be stored.

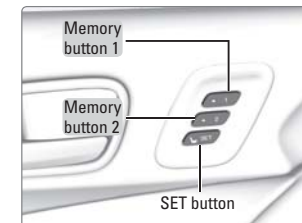

When you unlock and open the driver's door with a remote transmitter, the seat adjusts automatically to one of the two preset positions.

## Adjusting the Steering Wheel

The steering wheel height and distance from your body can be adjusted so that you can comfortably grip the steering wheel in an appropriate driving posture.

1. Pull up the steering wheel adjustment lever.
2. Move the steering wheel up or down, and in or out.
3. Push down the steering wheel adjustment lever to lock the steering wheel in position.



### ⚠ WARNING

Adjusting the steering wheel position while driving may cause you to lose control of the vehicle and be seriously injured in a crash.

Adjust the steering wheel only when the vehicle is stopped.

\*if equipped

## Adjusting the Mirrors

Adjust the angle of the mirrors for the best visibility when you are sitting in the correct driving position.

### Rearview Mirror with Day/Night Positions\*

Manually adjust the position to reduce headlight glare from vehicles behind you. Flip the tab to switch between day and night positions.

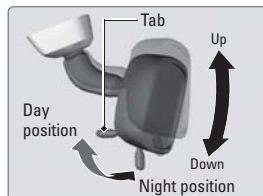

### Automatic Dimming Rearview Mirror\*

When driving after dark, the automatic dimming function reduces the glare from headlights behind you.

A green indicator appears when automatic dimming is on. The function cancels when the shift lever is in Reverse (R).

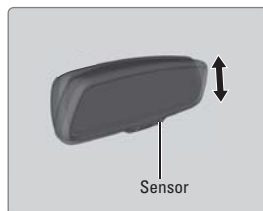

### Power Door Mirrors

Adjust the power door mirrors when the vehicle is on.

**L/R selector switch:** Select the left or right mirror. After adjusting the mirror, return the switch to the center position.

**Mirror position adjustment switch:** Press the switch left, right, up, or down to move the mirror.

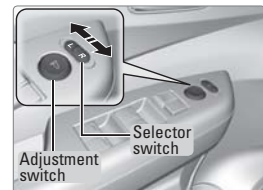

## HomeLink® Garage Opener\*

Program your vehicle to operate up to three remote-controlled devices around your home—such as garage doors, lighting, or home security systems—using the buttons on the ceiling.



### Training a Button

Park near the system you want to program, and follow the instructions in the flowchart below.

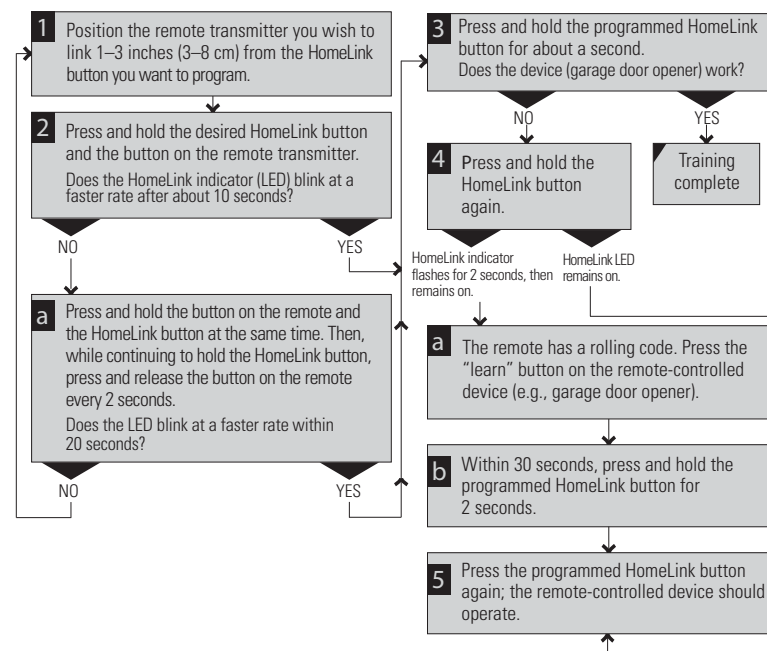

To retrain a button or erase codes, see the Owner's Manual on the Owner Information CD or at [owners.honda.com](http://owners.honda.com) (U.S.) or [www.myhonda.ca](http://www.myhonda.ca) (Canada). If you need help, visit [www.homelink.com](http://www.homelink.com).

\*if equipped

\*if equipped



### Air Conditioning System\*

Manually control the front heating and cooling in your vehicle's interior using the buttons on the dashboard.

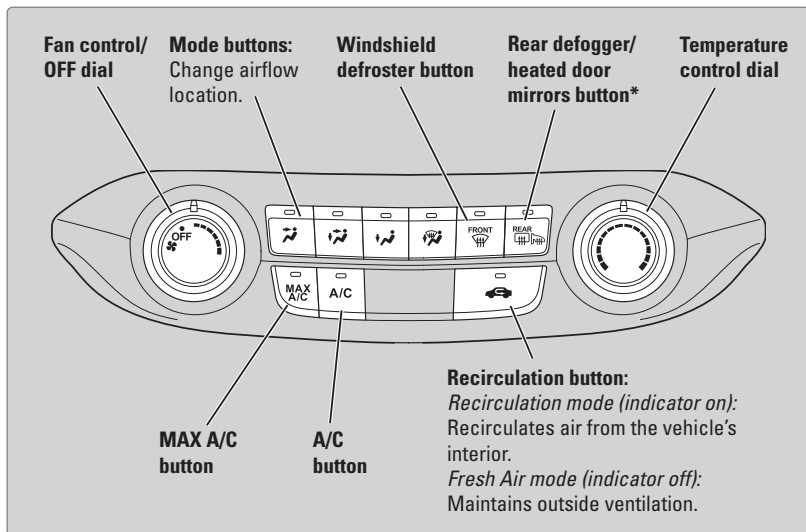

### Climate Control System\*

The automatic climate control system can maintain your preferred interior temperature by selecting the proper mix of heated or cooled air and fan speed. Use the buttons on the dashboard to control the system.

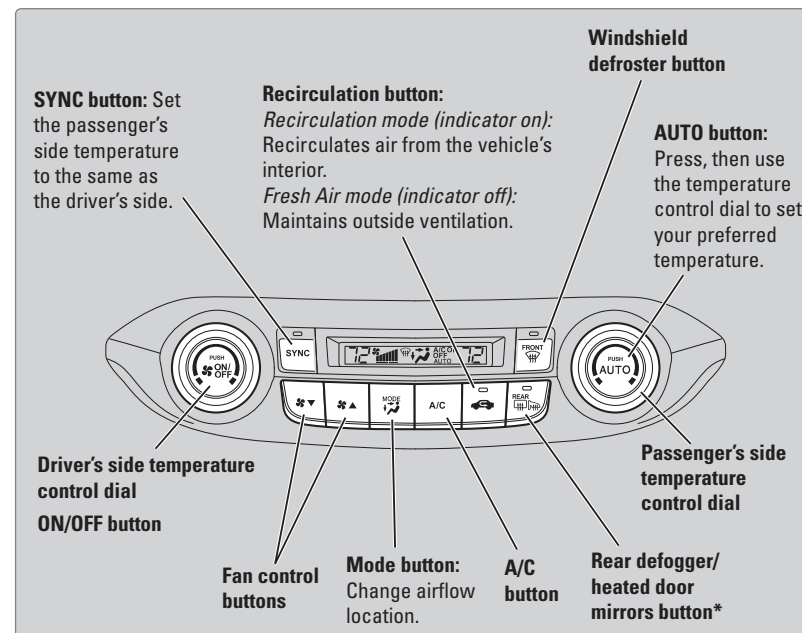

#### ■ Heated Windshield Button\*\*

Press the heated windshield button to deice the windshield when the vehicle is on.

When the outside temperature is below 4°C, the heated windshield may automatically activate. The system deactivates itself once the outside temperature reaches 6°C.

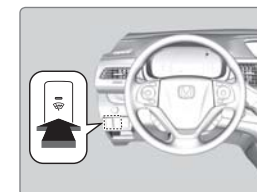

\*if equipped

\*if equipped  
 \*\*Canadian models

TABLE OF CONTENTS

VISUAL INDEX

SAFETY INFORMATION

INSTRUMENT PANEL

VEHICLE CONTROLS

AUDIO AND CONNECTIVITY

BLUETOOTH® HANDSFREELINK®

HONDALINK®

NAVIGATION

DRIVING

HANDLING THE UNEXPECTED

MAINTENANCE

SPECIFICATIONS

CUSTOMER INFORMATION

VOICE COMMAND INDEX

INDEX

## Seat Heaters\*

Quickly warm the front seats when the vehicle is on. Press the seat heater switch in the front console to select LO or HI.

**LO:** Slowly warm the seat, or to maintain continuous heating.

**HI:** Quickly warm the seat. If left in HI, the heater cycles on and off.



### ⚠ WARNING

Heat-induced burns are possible when using seat heaters.

Persons with a diminished ability to sense temperature (e.g., persons with diabetes, lower-limb nerve damage, or paralysis) or with sensitive skin should not use the seat heaters.

## Setting the Clock

Adjust the time using the steps described for your vehicle type.

### ■ Using the SETUP Button\*

Use this method for vehicles with one display. Use the selector knob to make and enter selections.

1. Press the SETUP button.
2. Select Adjust Clock.
3. Select the hour and adjust as necessary.
4. Select the minutes and adjust as necessary.
5. Select Set when complete.
6. Press the Back button to exit the menus.



### ■ Using the Settings Menu\*

Use this method for vehicles with touchscreen. Touch items to make selections.

1. From the HOME screen, select Settings.
2. Select the Clock/Info tab.
3. Select Clock Adjustment.
4. Adjust the hour and minute values.
5. Select OK when complete.



On vehicles with navigation, the time is automatically set using GPS signals.

\*if equipped

\*if equipped

# AUDIO AND CONNECTIVITY

Learn how to operate the vehicle's audio system.

## Basic Audio Operation

Connect audio devices and operate buttons and displays for the audio system.

### ■ USB Adapter Cable\*

1. Open the center console. Unclip the USB connector and loosen the adapter cable.
2. Connect a USB flash drive or other audio device, such as an iPod® or iPhone®.

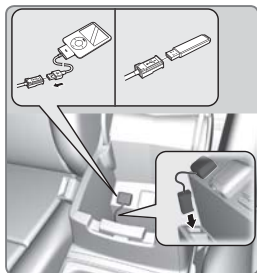

### ■ USB Port\*

1. Open the center console. Open one of the USB covers.
2. Insert a USB flash drive or other audio device, such as an iPod® or iPhone®, into the USB port.



*iPod and iPhone are trademarks of Apple, Inc.  
State or local laws may prohibit the operation  
of handheld electronic devices while operating a vehicle.*

### ■ Accessory Power Socket

Open the socket cover in the front console to use power when the vehicle is on. An additional power socket is also located in the center console.



### NOTICE

Do not insert an automotive type cigarette lighter element. This can overheat the power socket.

\*if equipped

### ■ HDMI Port\*

1. Open the center console. Open the HDMI cover.
2. Insert an HDMI cable to the HDMI port.



*Additional cables and connectors sold separately.*

### ■ Auxiliary Input Jack\*

Connect standard audio devices with a 1/8-inch (3.5 mm) stereo miniplug.

1. Open the AUX cover.
2. Insert the miniplug attached to the audio device into the jack. The audio system switches to AUX mode. Use the device to control the audio.

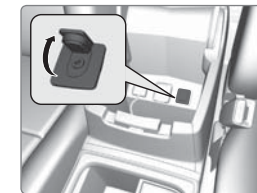

### ■ Steering Wheel Controls

You can operate certain functions of the audio system using the steering wheel controls.

**SOURCE button:** Cycle through available audio modes.

**◀/▶ buttons:** Change presets, tracks, albums, or folders.

**+/- buttons:** Adjust audio volume.

**MENU button:** From the audio screen, press and hold to choose options for the current audio mode (models with touchscreen).

#### FM/AM/XM® Radio

Press ◀ or ▶ for the next or previous station.

Press and hold ◀ or ▶ for the next or previous strong station.

#### CD/iPod®/USB/Bluetooth® Audio

Press ◀ or ▶ for the next or previous track.

Press and hold ◀ or ▶ for the next or previous folder (CD/USB).

#### Pandora®

Press ▶ for the next song.

Press and hold ◀ or ▶ for the next or previous station.



**Adjusting the Sound**

Adjust various sound settings.

**Models with one display**

Use the selector knob to make and enter selections.

1. Press the SETUP button.
2. Select Sound Settings.
3. Select a sound mode to change, and adjust it using the selector knob.
4. Press the Back button to exit the menu.

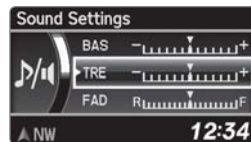

**Models with touchscreen**

Make selections using the touchscreen.

1. From the HOME screen, select Settings.
2. Select Audio.
3. Select Sound.
4. Select the tabs to change the sound mode and adjust the setting.
5. Select OK when complete.

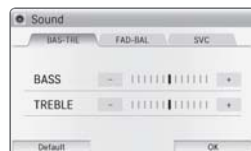

**Intelligent Multi-Information Display (i-MID)**

Display audio information. Use the buttons to control the display and audio system.

**Models with one display**

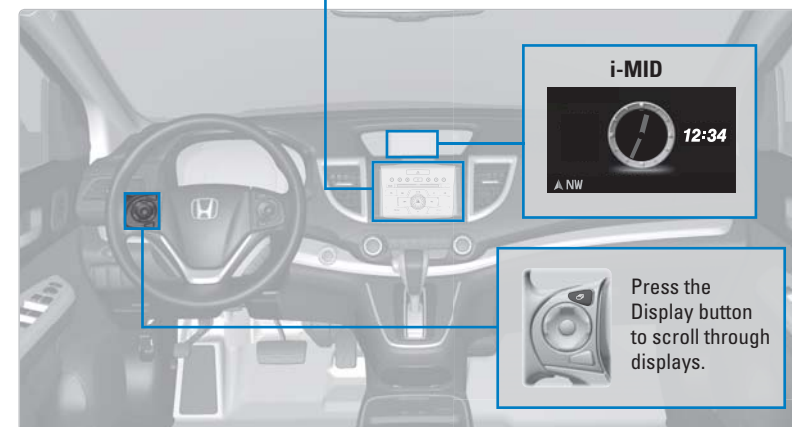
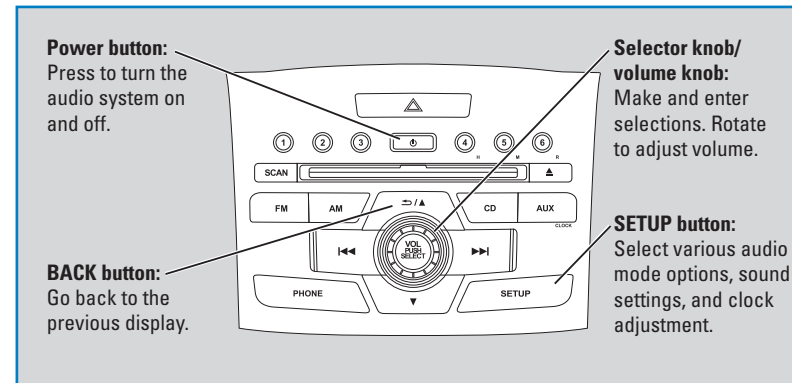

*\*if equipped*

## FM/AM Radio

Play FM or AM radio stations.

### Models with one display

**SCAN button:** Press to sample strong stations on the selected band. Press again to turn off scan.

**Preset buttons (1-6):** Press and hold a preset button to store the current station. Press a preset button to select a previously stored station.

**FM/AM button:** Select a band.

**(↔ / ▲ / ▼) buttons:** Press to display a radio data category. Press Seek/Skip to search the band for stations in that category.

**Selector knob:** Press and rotate to tune radio frequency.

**Seek/Skip buttons:** Search up and down the selected band for a station with a strong signal.

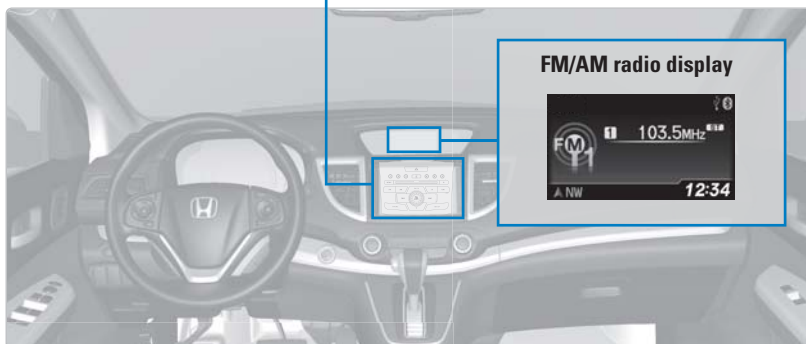

## Compact Disc (CD)

The audio system supports audio CDs, CD-Rs, and CD-RWs in MP3, WMA, or AAC formats.

### Models with one display

**SCAN button:** Press to sample each track. Press again to sample the first file in each folder. Press and hold to turn off scan.

**CD slot**

**CD button:** Play a CD.

**CD eject button**

**(↔ / ▲ / ▼) buttons:** Press to skip to the next or previous folder.

**Seek/Skip buttons:** Press to change tracks. Press and hold to move rapidly within a track.

**Selector knob:** Press to display the track or folder listing. Rotate to scroll through tracks, and select a track to play.

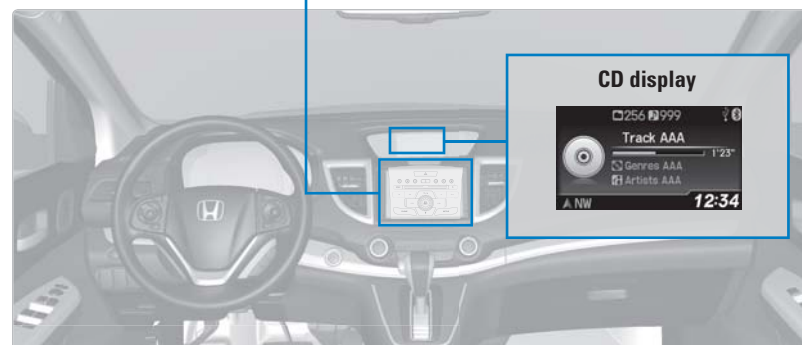

### NOTICE

Do not use CDs with adhesive labels or insert a damaged CD. Inserting these types of CDs may cause them to get stuck or damage the audio unit.

## iPod®

Play and operate an iPod through the vehicle's audio system.

### Models with one display

Connect your device (see page 54).

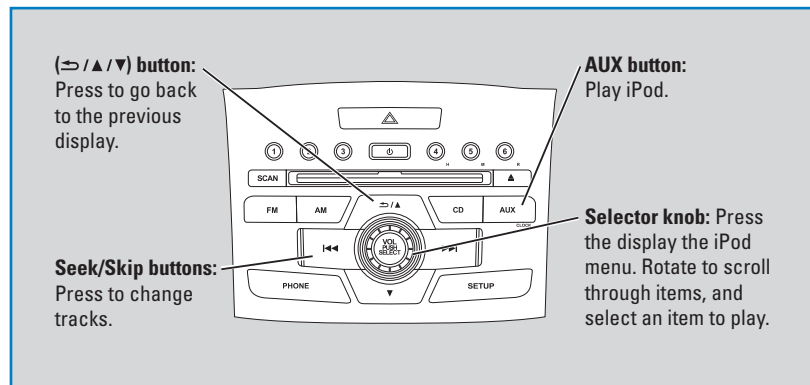

### ■ Searching for Music

Use the selector knob to search for tracks stored on the iPod.

1. From the audio screen, press the selector knob.
2. Select a search option.
3. Select the track you want to play.

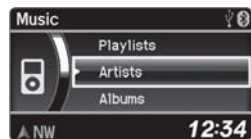

iPod is a trademark of Apple, Inc.

## USB Flash Drive

Play and operate a USB flash drive through the vehicle's audio system.

### Models with one display

Connect your device (see page 54).

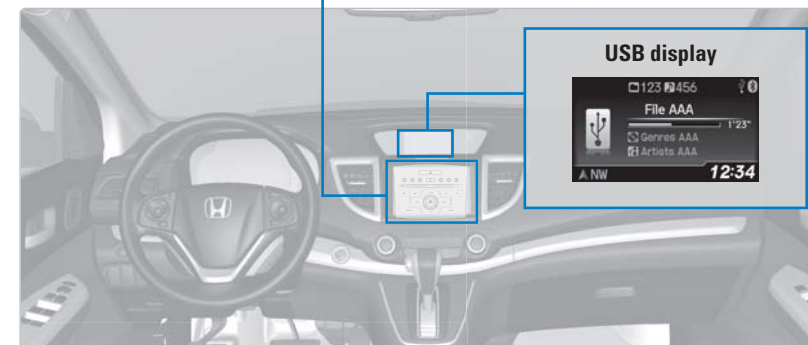
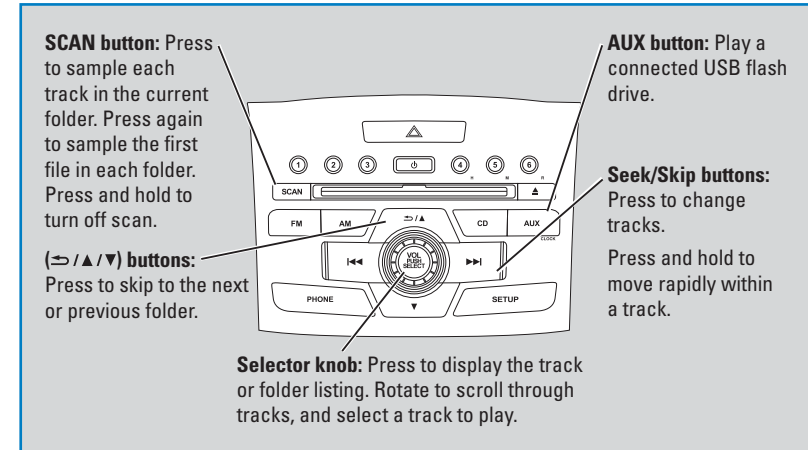

### ■ Searching for Music

Use the selector knob to search for tracks stored on the flash drive.

1. From the audio screen, press the selector knob.
2. Select a folder.
3. Select the track you want to play.



iPod is a trademark of Apple, Inc.



## Bluetooth® Audio

Play streaming or stored audio from your compatible phone through the vehicle's audio system. Visit [handsfreelink.com](http://handsfreelink.com) (U.S.) or [handsfreelink.ca](http://handsfreelink.ca) (Canada) to check phone compatibility. Standard data rates apply.

### Models with one display

Connect your phone to **Bluetooth® HandsFreeLink®** (see page 75).

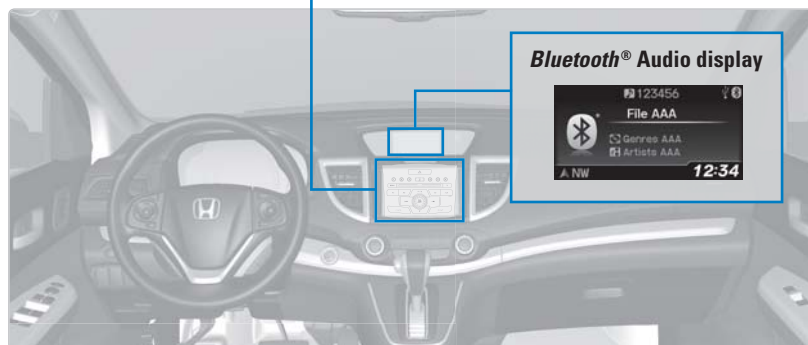
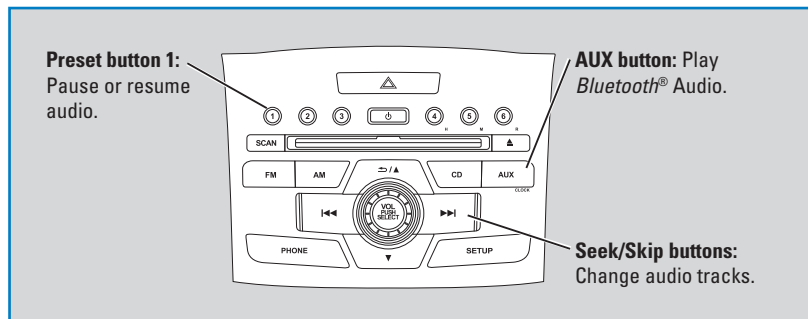

### Notes:

- Make sure the volume on your phone is properly adjusted.
- You may need to enable additional settings on your phone for playback.
- The resume/pause function and remote audio controls are not supported on all phones.

*State or local laws may prohibit the operation of handheld electronic devices while operating a vehicle. Only launch streaming audio on your phone when it is safe to do so.*

## Pandora®

Play and operate Pandora from your phone through the vehicle's audio system. Visit [handsfreelink.com](http://handsfreelink.com) to check phone compatibility. Standard data rates apply. **Available in the U.S. only.**

### Models with one display

Connect your phone when the vehicle is stopped.

#### For iPhone:

- Connect via **Bluetooth® HandsFreeLink®** (see page 75) or USB port (see page 54).
- A pop-up may appear on your phone requesting you to allow access for Pandora to be launched.
- If you cannot operate Pandora through the audio system, it may be streaming through **Bluetooth® Audio**. Make sure Pandora is selected on the audio system.
- If Pandora still does not operate, try rebooting the phone and reconnecting the cable if necessary.

#### For Android or BlackBerry:

- Connect via **Bluetooth® HandsFreeLink®** (see page 75).

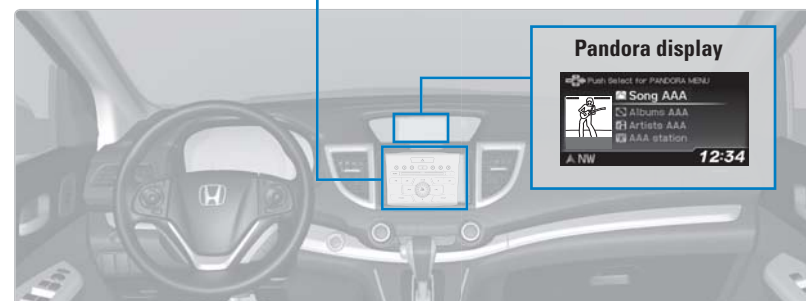
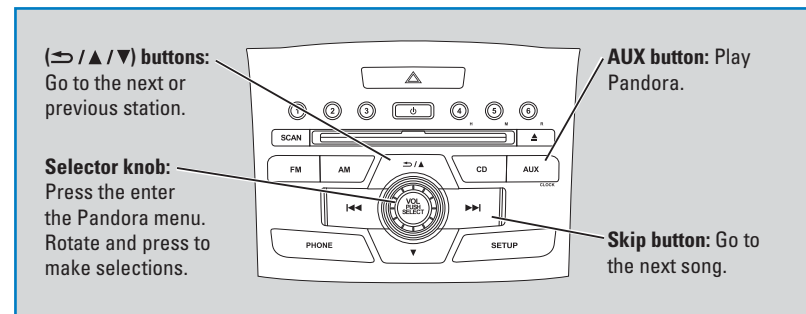

*State or local laws may prohibit the operation of handheld electronic devices while operating a vehicle. Only launch streaming audio on your phone when it is safe to do so.*

## Touchscreen Operation\*

Use simple gestures—including touching, swiping, and scrolling—to operate certain audio functions.

Some items may be grayed out during driving to reduce the potential for distraction. You can select them when the vehicle is stopped or use voice commands\*.

Wearing gloves may limit or prevent touchscreen response.

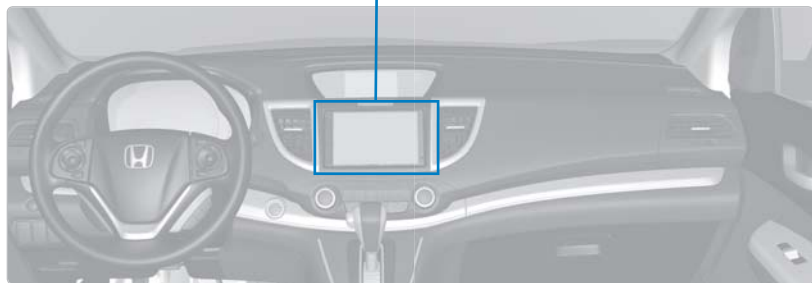
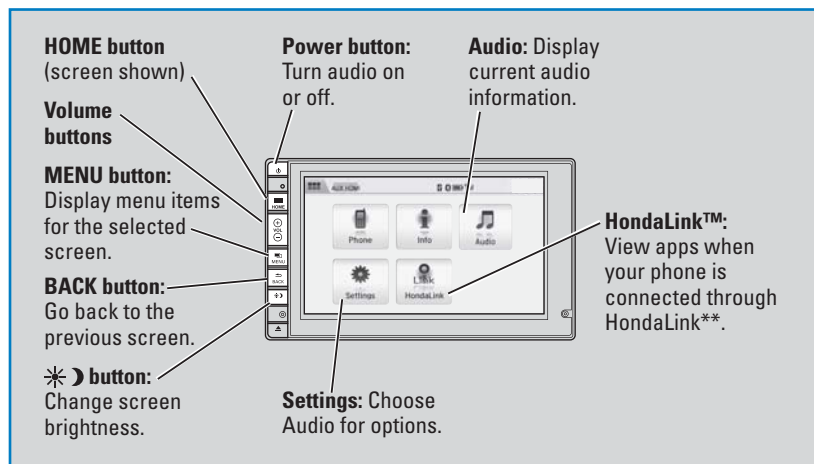

## Changing Icon Order

You can change the order of the icons on the Home screen.

1. From the Home screen, select Settings.
2. Select System.
3. Select Home.
4. Select Home Screen Edit Order.
5. Select and hold the icon you want to move and slide it to a different position.



## HondaLink™

You can connect a compatible smartphone to the audio system to enable integration between the smartphone's approved apps and the vehicle. This allows you to control the phone's apps through the touchscreen.

To check smartphone compatibility and connection instructions, visit [handsfreelink.com](http://handsfreelink.com).

To get more information on HondaLink features and apps, visit [www.hondalink.com](http://www.hondalink.com).

\*if equipped

\*\*HondaLink can be accessed only if the app is installed on your smartphone, and the phone is connected to the system (see page 65).

## FM/AM Radio

Play FM or AM radio stations.

### Models with touchscreen

**Source:** Select the FM or AM icon.

**Open/close:** Display or hide the station list or preset list.

**Scan:** Scan for each station with a strong signal.

**Seek:** Search for the next or previous station with a strong signal.

**Tune:** Change the station.

**Presets:** Select and hold a preset number to store the current station. Select a preset number to select a previously stored station.

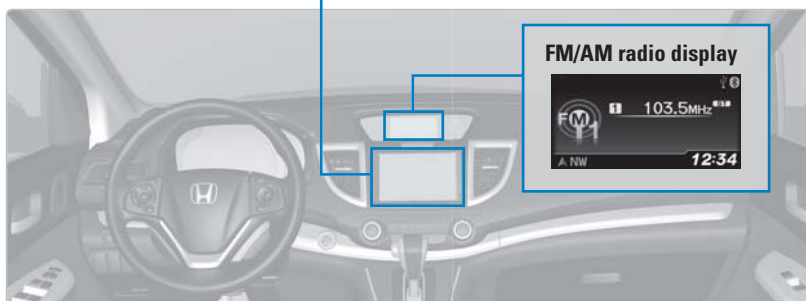

## SiriusXM® Radio\*

Available on a subscription basis only. For more information or to subscribe, contact your dealer, or visit [www.siriusxm.com](http://www.siriusxm.com) (U.S.) or [www.sirius.ca](http://www.sirius.ca) (Canada).

### Models with touchscreen

**Source:** Select the XM icon.

**Open/close:** Display or hide the channel list or preset list.

**Scan:** Scan for each station with a strong signal.

**Channel:** Change the channel.

**Category:** Change the category.

**Presets:** Select and hold a preset number to store the current station. Select a preset number to select a previously stored station.

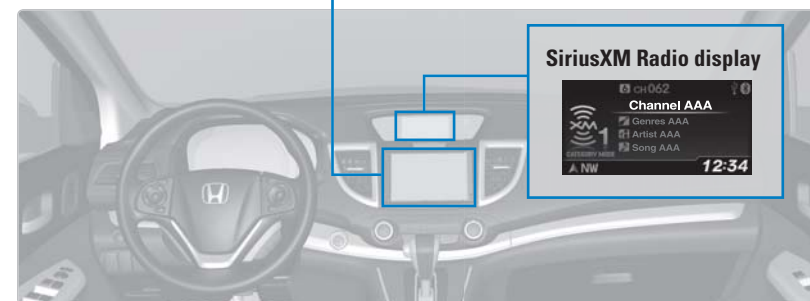

Available in the U.S. and Canada, except Hawaii, Alaska, and Puerto Rico. XM® is a registered trademark of Sirius XM Radio, Inc.

\*if equipped

## Compact Disc (CD)

The audio system supports audio CDs, CD-Rs, and CD-RWs in MP3, WMA, or AAC formats.

### Models with touchscreen

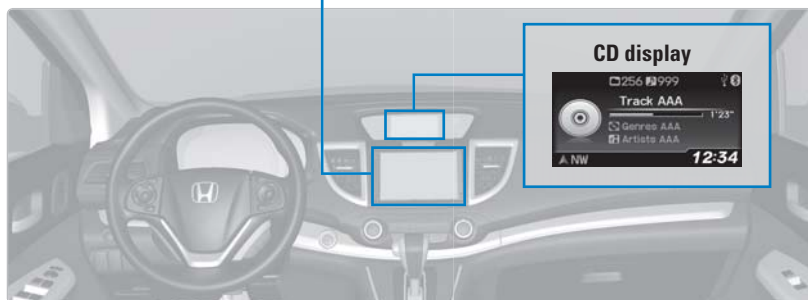
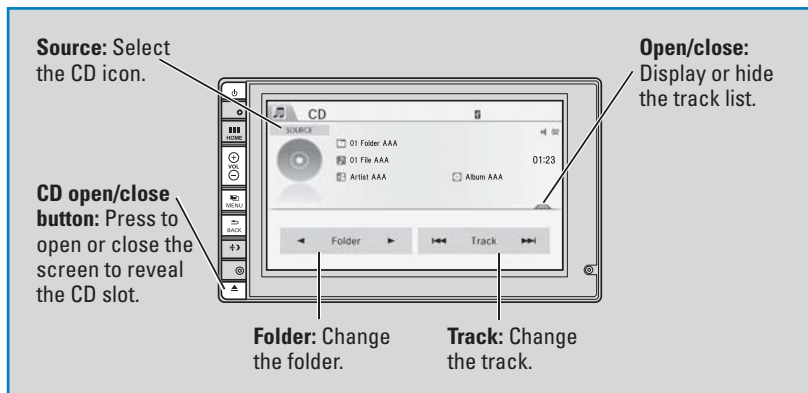

#### NOTICE

Do not use CDs with adhesive labels or insert a damaged CD. Inserting these types of CDs may cause them to get stuck or damage the audio unit.

## iPod®

Play and operate an iPod through the vehicle's audio system.

### Models with touchscreen

Connect your device to the USB port (see page 54).

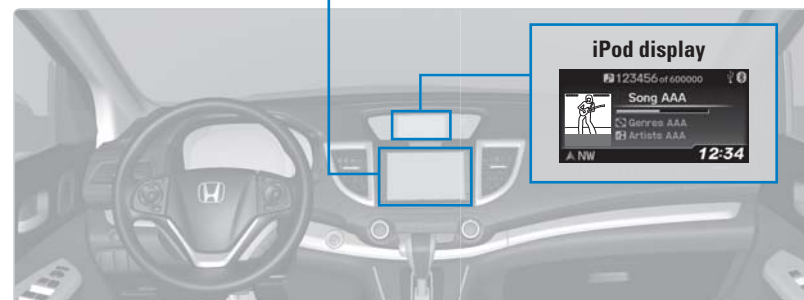
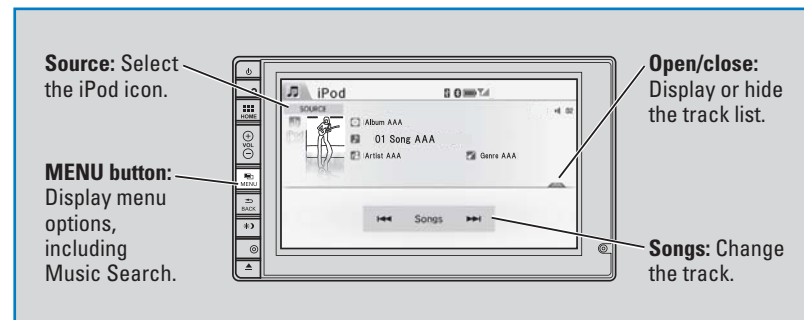

### Searching for Music

Use the touchscreen to search for tracks stored on the iPod.

1. From the audio screen, press MENU.
2. Select Music Search.
3. Select a search option.
4. Select the track you want to play.



## USB Flash Drive

Play and operate a USB flash drive through the vehicle's audio system.

### Models with touchscreen

Connect your device to the USB port (see page 54).

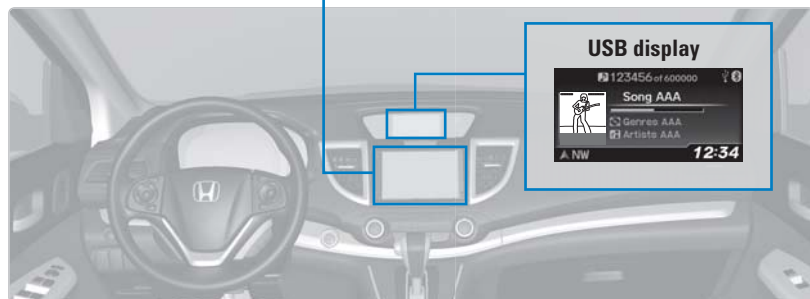
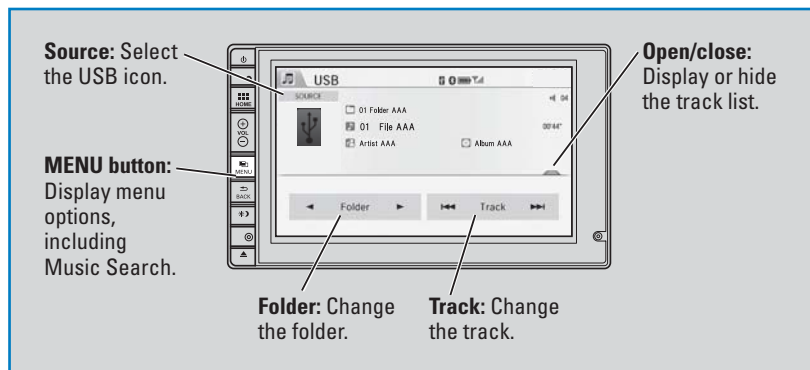

### ■ Searching for Music

Use the touchscreen to search for tracks stored on the USB flash drive.

1. From the audio screen, press MENU.
2. Select Music Search.
3. Select a folder.
4. Select the track you want to play.



## Bluetooth® Audio

Play streaming or stored audio from your compatible phone through the vehicle's audio system. Visit [handsfreelink.com](http://handsfreelink.com) (U.S.) or [handsfreelink.ca](http://handsfreelink.ca) (Canada) to check phone compatibility. Standard data rates apply.

### Models with touchscreen

Connect your phone to *Bluetooth®* HandsFreeLink® (see page 80).

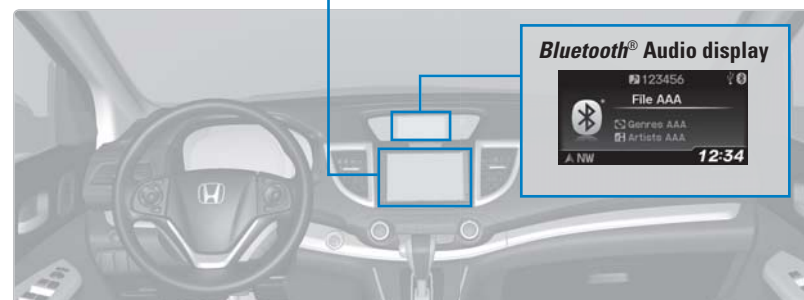
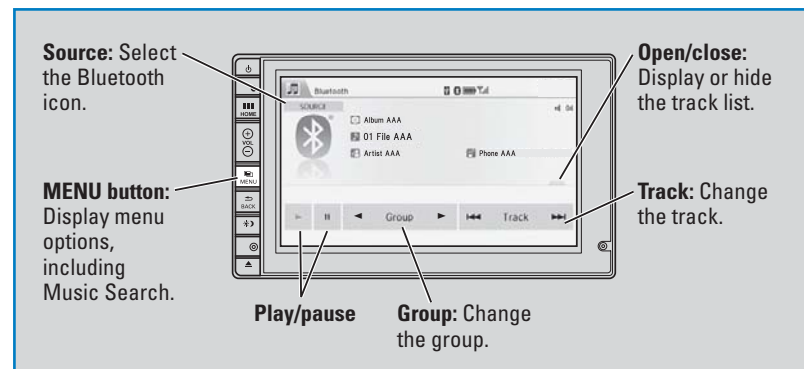

### Notes:

- Make sure the volume on your phone is properly adjusted.
- You may need to enable additional settings on your phone for playback.
- The resume/pause function and remote audio controls are not supported on all phones.

*State or local laws may prohibit the operation of handheld electronic devices while operating a vehicle. Only launch streaming audio on your phone when it is safe to do so.*

## Pandora®

Play and operate Pandora from your compatible phone through the vehicle's audio system. Visit [handsfreelink.com](http://handsfreelink.com) to check phone compatibility. Standard data rates apply. **Available in the U.S. only.**

### Models with touchscreen

Connect your phone when the vehicle is stopped.

#### For iPhone:

- Connect via *Bluetooth*® HandsFreeLink® (see page 80) or USB port (see page 54).
- A pop-up may appear on your phone requesting you to allow access for Pandora to be launched.
- If you cannot operate Pandora through the audio system, it may be streaming through *Bluetooth*® Audio. Make sure Pandora is selected on the audio system.
- If Pandora still does not operate, try rebooting the phone and reconnecting the cable if necessary.

#### For Android or BlackBerry:

- Connect via *Bluetooth*® HandsFreeLink® (see page 80).

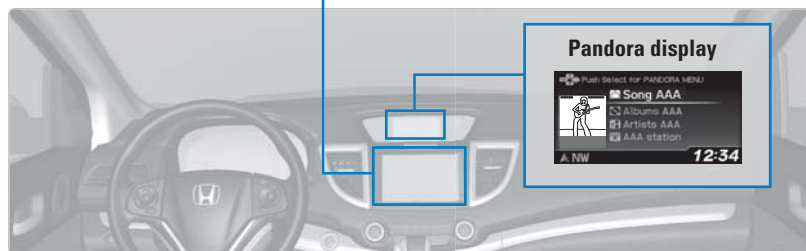
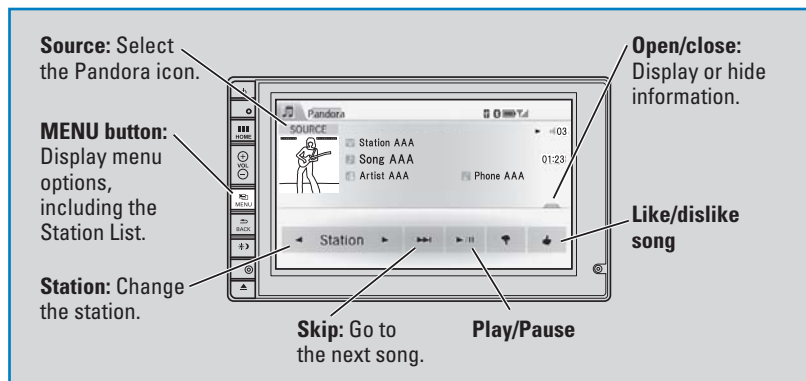

*State or local laws may prohibit the operation of handheld electronic devices while operating a vehicle. Only launch streaming audio on your phone when it is safe to do so.*

## HDMI Video

Play video from a compatible device through your vehicle.

### Models with touchscreen

Connect your device to the HDMI port (see page 55). From the connected device, launch the video you want to display on the touchscreen. This feature is limited while the vehicle is moving.

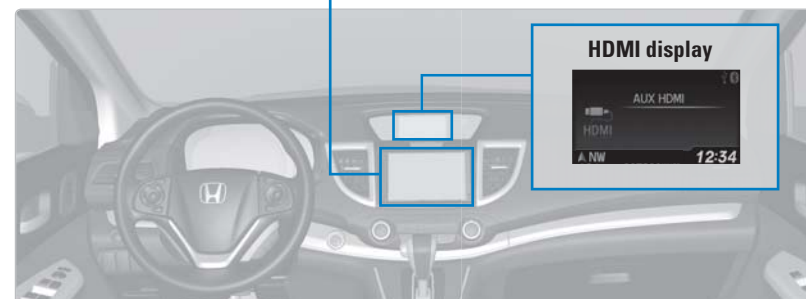

The device or video resolution must be 720p or lower to view in the touchscreen.



# BLUETOOTH® HANDSFREELINK® (HFL)

Learn how to operate the vehicle's hands-free calling system.

## Basic HFL Operation

Make and receive phone calls using the vehicle's audio system, without handling your phone. Visit [handsfreelink.com](http://handsfreelink.com) (U.S.) or [handsfreelink.ca](http://handsfreelink.ca) (Canada) to check phone compatibility.

**To reduce the potential for driver distraction, certain manual functions may be inoperable or grayed out while the vehicle is moving. Stop or pull over to perform the function.**

### Models with one display

#### HFL Controls

Use the controls to enter information and make selections.

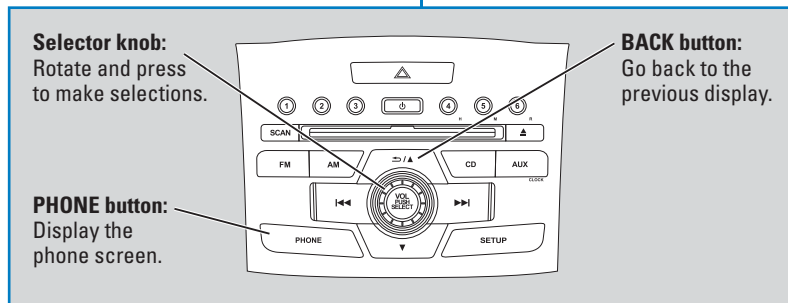
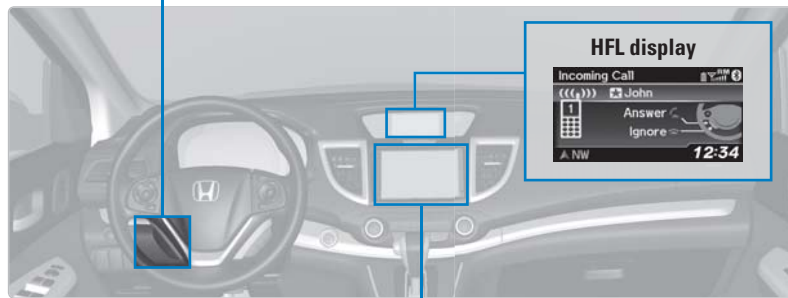
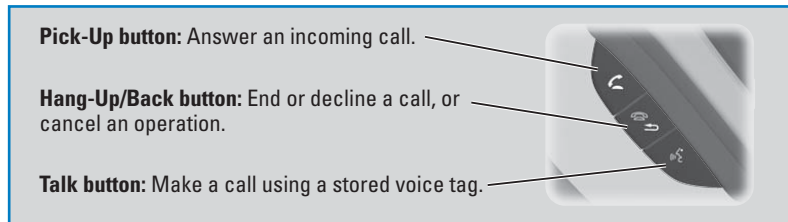

### Models with one display

## Pairing a Phone

To use hands-free phone and streaming audio functions, you must first pair your phone to the system. This can only be done when the vehicle is stopped. Use the selector knob to make and enter selections.

#### Pairing the First Phone

1. Press PHONE to go to the Phone screen. A prompt appears. Select Yes.
2. Make sure your phone is in discovery mode. Select OK.
3. HFL searches for your phone. Select your phone when it appears on the list.  
*If your phone does not appear:* Select Phone Not Found and search for HandsFreeLink from your phone. Connect to HFL.
4. HFL gives you a four-digit code. Compare it to the code that appears on your phone. Connect to HFL from your phone.

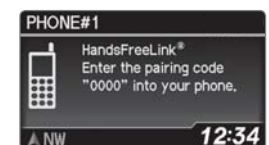

#### Pairing an Additional Phone

1. Press PHONE to go to the Phone screen. If a prompt appears asking to connect to a phone, select No.
2. Select Phone Setup.
3. Select Connection.
4. Select Add a New Phone.
5. Select an empty location for the phone.
6. Make sure your phone is in discovery mode. Select OK.
7. HFL searches for your phone. Select it when it appears on the list.  
*If your phone does not appear:* Select Phone Not Found, and search for HandsFreeLink from your phone. Connect to HFL.
8. HFL gives you a four-digit code. Enter it on your phone when prompted.

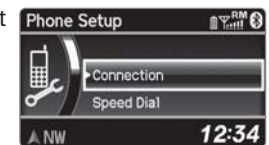

State or local laws may prohibit the operation of handheld electronic devices while operating a vehicle.

## Models with one display

## Making a Call

You can make a call using several methods.

### ■ Dialing a Number

Enter a 10-digit phone number to call. Use the selector knob to make and enter selections. This method is inoperable while the vehicle is moving.

1. Press PHONE.
2. Select Dial.
3. Enter the phone number. Select the green phone icon to call.



### ■ Using the Phonebook

When your phone is paired, its entire phonebook can be automatically imported to the system. Use the selector knob to make and enter selections. This method is inoperable while the vehicle is moving.

1. Press PHONE.
2. Select Phonebook.
3. Scroll through the list to find the name and number you want to call, and select it to call.



### ■ Storing Speed Dial Entries

Store up to 20 numbers for quick dialing. Use the selector knob to make and enter selections.

1. Press PHONE.
2. Select Phone Setup
3. Select Speed Dial, then select Add New.
4. Select an entry method.
5. If desired, you can create a voice tag for the number. Follow the prompts.



### ■ Using Speed Dial

Make calls quickly using stored speed dial entries. Use the selector knob to make and enter selections.

1. Press PHONE.
2. Select Speed Dial.
3. Scroll through the list to find the entry you want to call, and select it to call.



Speed dial entries with stored voice tags can be called using the Talk button. Press the Talk button and follow the prompts.

## Models with one display

## SMS Text Messaging

Receive and send messages from your paired and connected phone. Visit [handsfreelink.com](http://handsfreelink.com) (U.S.) or [handsfreelink.ca](http://handsfreelink.ca) (Canada) to check phone compatibility. Standard message rates apply. This feature is limited while the vehicle is moving.

### ■ Receiving and Responding to Messages

When you receive a new message, a pop-up appears on the display. Use the selector knob to view the message when the vehicle is stopped. You can also reply to it using fixed phrases or call the sender.

1. When the prompt appears, select Yes.
2. The message is displayed, and the system reads it aloud.

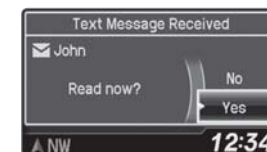

*To reply:* With the message open, press the selector knob to enter the Text Message Menu. Select Reply, and choose one of the six available responses. Select Yes to send the message. You cannot create a new text message.

*To call the sender:* With the message open, press the selector knob to enter the Text Message Menu. Select Call.

## Basic HFL Operation

Make and receive phone calls using the vehicle's audio system, without handling your phone. Visit [handsfreelink.com](http://handsfreelink.com) (U.S.) or [handsfreelink.ca](http://handsfreelink.ca) (Canada) to check phone compatibility.

**To reduce the potential for driver distraction, certain manual functions may be inoperable or grayed out while the vehicle is moving. Stop or pull over to perform the function. Voice commands are also available.**

Models with touchscreen

### HFL Controls

Use the controls to enter information and make selections.

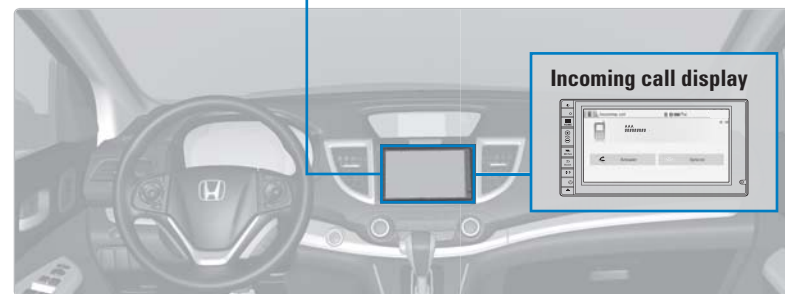
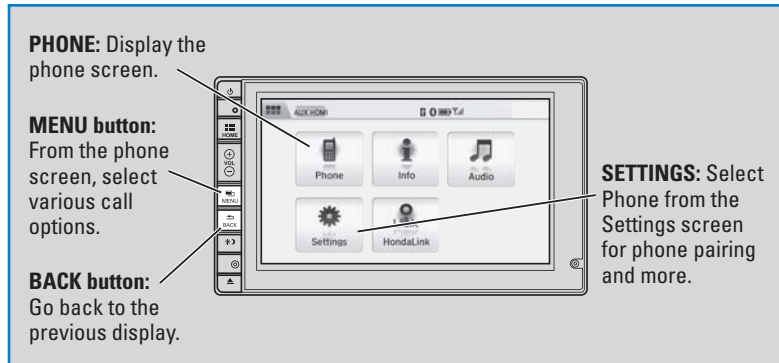
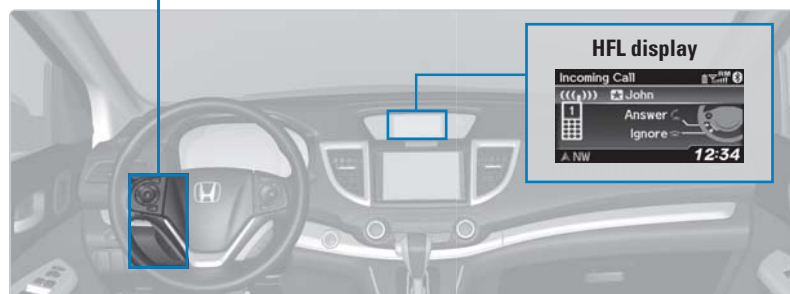
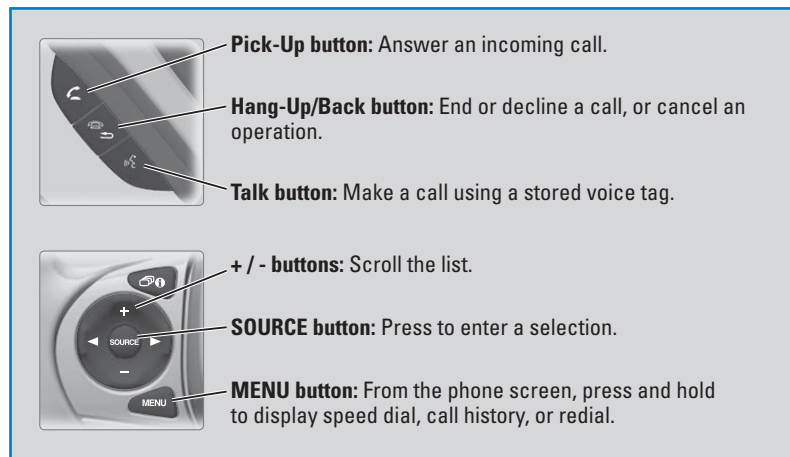

### Voice Recognition Tips

- When using the Talk button, wait for a beep before saying a command.
- To bypass the system prompts, simply press the Talk button again to say your command.
- When the Talk button is pressed, all available voice commands are highlighted in yellow.
- Speak in a clear, natural voice.
- Reduce all background noise.
- Adjust the dashboard and side vents away from the microphone in the ceiling.
- Close the windows and moonroof.

Models with touchscreen

### Pairing a Phone

To use hands-free phone and streaming audio functions, you must first pair your phone to the system. This can only be done when the vehicle is stopped. Use the touchscreen to make and enter selections.

1. From the Home screen, select Settings.
2. Select Phone.
3. Select Bluetooth Device List
4. Select Add Bluetooth Device.
5. Make sure your phone is in discovery mode. Select OK.
6. HFL searches for your phone. Select your phone when it appears on the list.  
*If your phone does not appear:* Select Phone Not Found and search for HandsFreeLink from your phone. Connect to HFL.
7. HFL gives you a six-digit code. Compare it to the code that appears on your phone. Connect to HFL from your phone.
8. The system asks if you want to enable options:  
*HondaLink Assist:* Select On to enable emergency collision notification (see page 84).  
*Phone Synchronization:* Select On to automatically import contacts and call history from your phone.
9. Press BACK to exit the menu.



*State or local laws may prohibit the operation of handheld electronic devices while operating a vehicle.*

Models with touchscreen

### Making a Call

You can make a call using several methods.

#### Dialing a Number

Enter a 10-digit phone number to call.

#### Using voice commands

Press the Talk button before you say each command.

1. Say "Dial by number."
2. Say the phone number: For example, "3-1-0-5-5-5-1-2-3-4."
3. The system begins to dial.



#### Using the touchscreen

Manual operation is limited while the vehicle is moving. Voice commands are always available.

1. From the Home screen, select Phone.
2. Select MENU.
3. Select Dial.
4. Enter the phone number. Select the green phone icon to call.



#### Using the Phonebook

When your phone is paired, its entire phonebook can be automatically imported to the system. Phone synchronization must be turned on.

#### Using voice commands

Press the Talk button before you say each command.

1. Say "Dial by name."
2. Say the phonebook name and phone type. For example, "John Smith mobile."

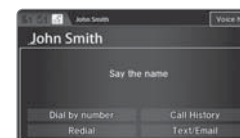

#### Using the touchscreen

Manual operation is limited while the vehicle is moving. Voice commands are always available.

1. From the Home screen, select Phone.
2. Select MENU.
3. Select Phonebook.
4. Scroll through the list to find the name and number you want to call, and select it to call.



## ■ Storing Speed Dial Entries

Store up to 20 numbers for quick dialing.

1. From the Home screen, select Phone.
2. Select MENU.
3. Select Edit Speed Dial, then select New Entry.
4. Select an entry method.
5. If desired, you can create a voice tag for the number. Follow the prompts.

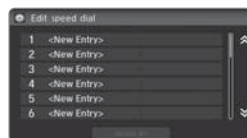

## ■ Using Speed Dial

Make calls quickly using stored speed dial entries.

### Using voice commands

Press the Talk button before you say each command.

1. Say "Dial by name."
2. Say the stored voice tag name. For example, "John Smith."



### Using the touchscreen

1. From the Home screen, select Phone.
2. Scroll through the list to find the entry you want to call, and select it to call.



## Models with touchscreen

### SMS Text Messaging and E-Mail\*

Receive and send messages from your paired and connected phone. Visit [handsfreelink.com](http://handsfreelink.com) (U.S.) or [handsfreelink.ca](http://handsfreelink.ca) (Canada) to check phone compatibility. Standard message rates apply. This feature is limited while the vehicle is moving.

#### ■ Receiving and Responding to Messages

When you receive a new message, a pop-up appears on the touchscreen. You can view the message when the vehicle is stopped. You can also reply to it using fixed phrases or call the sender.

1. When the prompt appears, select Read.
2. The message is displayed, and the system reads it aloud.

*To reply:* With the message open, select Reply, and choose one of the six available responses. Select Send to send the message. You cannot create a new text message.

*To call the sender:* With the message open, select Call.

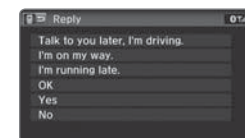
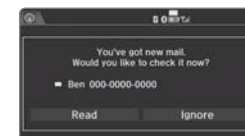

#### ■ Selecting an Account

If your phone has both text message and e-mail accounts, you can select only one of them at a time to be active and receive notifications.

1. From the Home screen, select Settings.
2. Select Phone.
3. Select Select Account.
4. Select Text Message or an e-mail account.

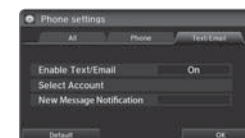

\*if equipped



Models with touchscreen

### HondaLink™ Assist

Automatically connect and talk to an operator who can locate your vehicle and send emergency help in the event of a collision. Visit [www.hondalink.com](http://www.hondalink.com) (U.S.) or [honda.ca/hondalinkassist](http://honda.ca/hondalinkassist) (Canada) for more information.

1. Make sure your phone is on and paired to *Bluetooth®* HandsFreeLink® (see page 80).
2. Select Call Now, or the system automatically connects after 10 seconds. The vehicle information and its position are sent to the operator.
3. Select Talk Now to immediately talk to the operator.
4. When the call is complete, select Hang Up or press the Hang Up/Back button on the steering wheel.



### Siri™ Eyes Free

Activate Siri through your vehicle when an iPhone® is paired to the system. Visit [handsfreelink.com](http://handsfreelink.com) (U.S.) or [honda.ca/siri](http://honda.ca/siri) (Canada) to check phone compatibility.

**Hang-Up/Back button:** Exit Siri Eyes Free mode, or cancel a command.

**Talk button:** Press and hold to activate Siri Eyes Free mode. The Smartphone screen appears. Say your command after you hear the Siri tone. If you only press and release the Talk button, the standard voice recognition system is activated.



Here are some examples of Siri commands:

- |   |   |
|---|---|
| <i>"Call John Smith"</i>                | <i>"Remind me to pick up dinner"</i>      |
| <i>"Read my new text message"</i>       | <i>"Set up a meeting today at 3 p.m."</i> |
| <i>"Find a nearby sushi restaurant"</i> | <i>"Play song XYZ"</i>                    |

**Notes:**

- Any requests that include visual feedback from Siri on your phone are not displayed in the vehicle.
- Certain commands rely on the iPhone's features and existing apps.
- To hear turn-by-turn directions or songs through the vehicle, set the audio source to *Bluetooth®* Audio.

*Siri and iPhone are trademarks of Apple, Inc.*

## NAVIGATION\*

Learn how to enter a destination and operate the navigation system.

### Basic Navigation Operation

A real-time navigation system uses GPS and a map database to show your current location and help guide you to a desired destination. You can operate the system using voice commands or the touchscreen.

**To reduce the potential for driver distraction, certain manual functions may be inoperable or grayed out while the vehicle is moving. Voice commands are always available.**

#### Steering Wheel Controls

Use the steering wheel controls to control the system.

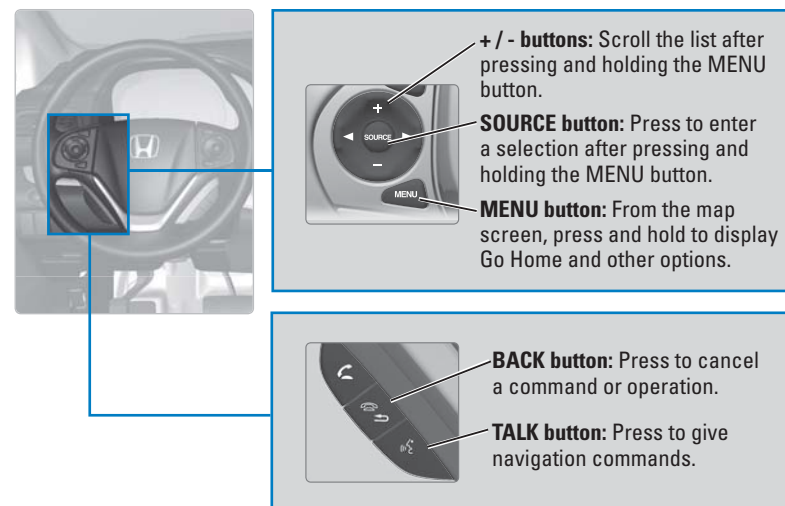

**⚠ WARNING**

Using the navigation system while driving can take your attention away from the road, causing a crash in which you could be seriously injured or killed. Operate system controls only when the conditions permit you to safely do so.

\*if equipped

TABLE OF CONTENTS  
VISUAL INDEX  
SAFETY INFORMATION  
INSTRUMENT PANEL  
VEHICLE CONTROLS  
AUDIO AND CONNECTIVITY  
BLUETOOTH® HANDSFREELINK®  
HONDALINK®

NAVIGATION  
DRIVING  
HANDLING THE UNEXPECTED  
MAINTENANCE  
SPECIFICATIONS  
CUSTOMER INFORMATION  
VOICE COMMAND INDEX  
INDEX



**Navigation Display and Controls**

Use the touchscreen to enter information and make selections.

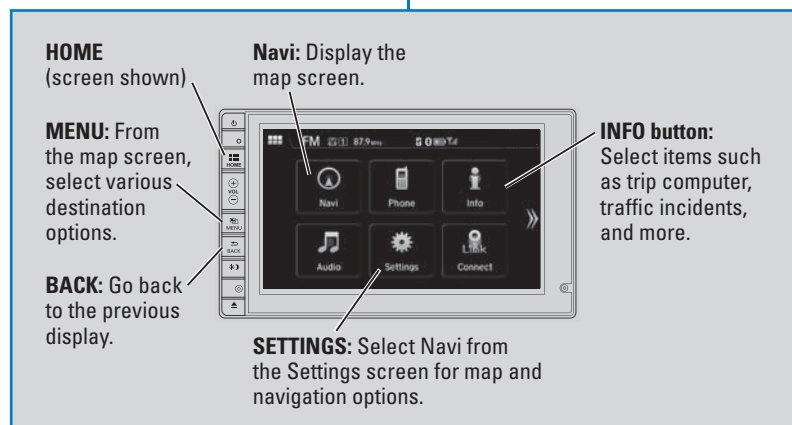
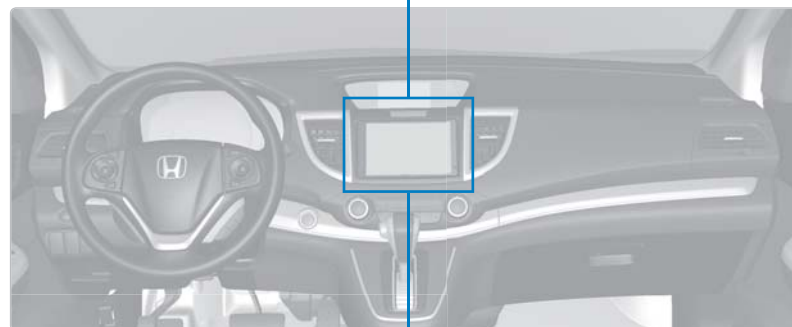
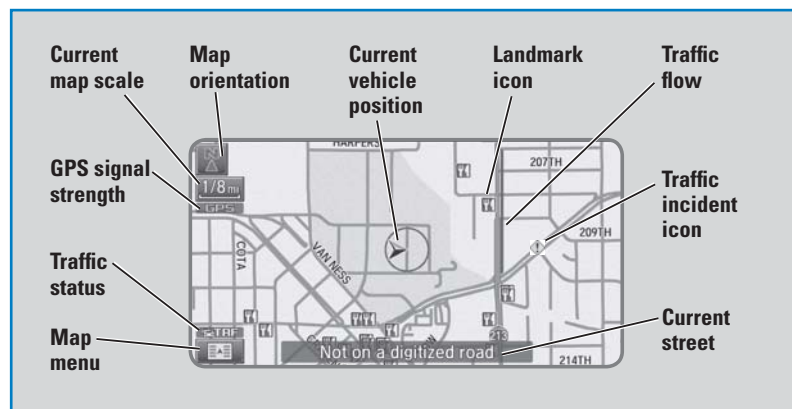

**Voice Prompt Volume**

Adjust volume for navigation and voice command confirmation. This does not affect audio or Bluetooth® HandsFreeLink® volume, which is controlled by the volume bar.

1. From the Home Screen, select Settings.
2. Select System.
3. Select Volume.
4. Adjust the level, or select off.



**Voice Prompt**

Turn the voice feedback feature on or off.

1. From the Home screen, select Settings.
2. Select System.
3. Select Voice Prompt.
4. Select On or Off.



**Voice Recognition Tips**

- When using the Talk button, wait for a beep before saying a command.
- To bypass the system prompts, simply press the Talk button again to say your command.
- When the Talk button is pressed, all available voice commands are highlighted in yellow.
- Speak in a clear, natural voice.
- Reduce all background noise.
- Adjust the dashboard and side vents away from the microphone in the ceiling.
- Close the windows and moonroof.

## Entering a Destination

Use multiple methods to enter a destination.

### Home Address

Store your home address in the system so you can easily route to it.

1. From the Home screen, select Settings.
2. Select Navigation.
3. Select Edit Go Home (1 or 2).
4. Enter the address, and select OK when complete.



When your home address is stored, you can press the Talk button and say "Go home" at any time. You can also select Go home from the navigation menu.

### Street Address

Enter a street address using voice commands. Press the Talk button before saying each command.

You can also enter the address manually when the vehicle is stopped. From the map screen, press MENU and select Address. Follow the prompts.

#### U.S. models

1. From the Voice Portal screen, say "Address."
2. The system prompts you to say the entire address. For example, say "1-2-3-4 Main Street, Los Angeles, California."
3. The system interprets the address by state, city, street, and address number. If necessary, you may have to clarify similar matches.
4. Say "Set as destination" to set the route.

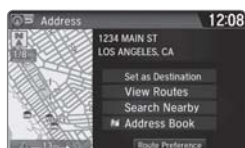
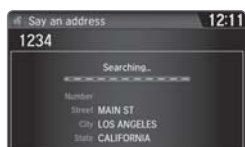
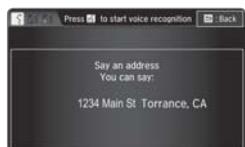

#### Canadian models

1. From the Voice Portal screen, say "Address."
2. Follow the prompts.

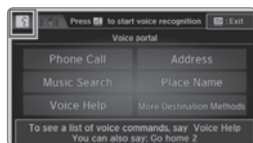

### Place Category

Enter a destination or point of interest using voice commands. Press the Talk button before saying each command.

You can also enter the place name manually when the vehicle is stopped. From the map screen, press MENU and select Place Name. Follow the prompts.

1. From the Voice Portal screen, say "Place name."
2. Say a category, for example "ATM/Bank."
3. Say the name of the place, for example "ABC Bank."
4. The system interprets the name. If necessary, you may have to clarify similar matches.
5. Say "Set as destination" to set the route.

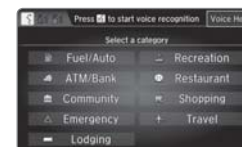

### Find Nearest Place

Enter a destination by category and distance using voice commands. Press the Talk button before saying each command.

1. Say "Find nearest" and a place. For example, "Find nearest ATM."
2. A list of the nearest places in your area is displayed by shortest distance to destination.
3. Say the number next to the destination you want to select.
4. Say "Set as destination" to set the route.



## Routing

After a destination is set, you can alter or cancel your route.

### Map Legend

#### Turn-by-Turn Directions

Shows a more detailed view of the next maneuver on the i-MID.

Distance to next maneuver



Upcoming maneuver

Current route

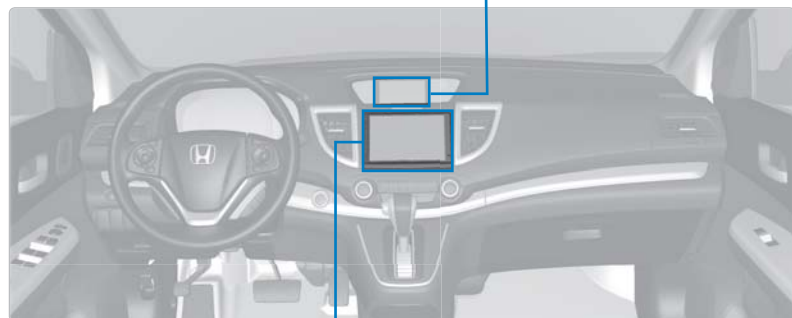

#### During route guidance

Estimated time to destination



Next guidance point

Calculated route

Distance to destination

### Taking a Detour

You can calculate a detour route manually if you encounter a road closure or other obstacle.

1. When en route, press MENU from the map screen.
2. Select Detour. The system attempts to calculate a new route by avoiding the next 5 miles (8 km) while on a freeway or 1 mile (1 km) while on a surface street.

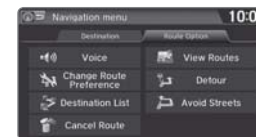

### Traffic

View traffic flow, incidents, and construction in major metro areas. You can also route around congestion or incidents using voice commands. Press the Talk button before saying each command. **Available on U.S. models only.**

1. When en route, say "Display traffic incidents." A list of incidents on your route appears.
2. Say the number of the incident you want to avoid.
3. Say "Avoid" and the incident list returns.
4. Say "Recalculate route" to set the new route.



### Canceling Your Route

You can cancel your route at any time.

1. When en route, press MENU from the map screen.
2. Select Cancel Route. The route is cleared and the map screen returns. You can also press the Talk button and say "Cancel route."



# DRIVING

Learn about preparation for driving, as well as other features.

## Before Driving

Check the following items before you begin driving.

### ■ Exterior Checks

- Make sure there are no obstructions on the windows, door mirrors, exterior lights, or other parts of the vehicle.
- Remove any frost, snow, or ice.
- Make sure the hood is securely closed.
- Heat from the engine and exhaust can ignite flammable materials left under the hood, causing a fire. If you've parked your vehicle for an extended period, inspect and remove any debris that may have collected, such as dried grass and leaves that have fallen or have been carried in for use as a nest by a small animal. Also check under the hood for leftover flammable materials after you or someone else has performed maintenance on your vehicle.
- Make sure the tires are in good condition.
- Make sure there are no people or objects behind or around the vehicle.

### NOTICE

If the doors are frozen shut, use warm water around the door edges to melt any ice. Do not try to force them open, as this can damage the rubber trim around the doors. When done, wipe dry to avoid further freezing.

### ■ Interior Checks

- Store or secure all items on board properly.
- Do not pile items higher than the seat height.
- Do not place anything in the front seat footwells. Make sure to secure the floor mats.
- If you have any animals on board, do not let them move freely around in the vehicle.
- Securely close and lock all doors and the tailgate.
- Adjust your seating position, mirrors, and steering wheel properly.
- Make sure items placed on the floor behind the front seats cannot roll under the seats.
- Everyone in the vehicle must fasten their seat belt.
- Make sure that the indicators in the instrument panel come on when you start the vehicle, and go off soon after.

In addition:

- During the first 600 miles (1,000 km) of operation, avoid sudden acceleration or full throttle operation so as not to damage the engine or powertrain.
- Avoid hard braking for the first 200 miles (300 km). You should also follow this when the brake pads are replaced.

### ⚠ WARNING

Improper accessories or modifications can affect your vehicle's handling, and stability, and performance, and cause a crash in which you can be seriously hurt or killed.

Follow all instructions in the vehicle owner's manual regarding accessories and modifications.

Your vehicle has been designed primarily for use on pavement; however, its higher ground clearance allows you to occasionally travel on unpaved roads. It is not designed for trail-blazing or other challenging off-road activities.

If you decide to drive on unpaved roads, you will find that it requires somewhat different driving skills and that your vehicle will handle somewhat differently than it does on pavement. Pay attention to the precautions and tips in this section, and get acquainted with your vehicle before leaving the pavement.

### ⚠ WARNING

Improperly operating this vehicle on or off pavement can cause a crash or rollover in which you and your passengers can be seriously hurt or killed.

Follow all instructions and guidelines in this guide.

Keep your speed low, and don't drive faster than conditions permit.

## Maximum Load Limit

Carrying too much cargo or improperly storing it can affect your vehicle's handling, stability, stopping distance, and tires, and make it unsafe.

The maximum load for your vehicle is 850 lbs (385 kg). See the Tire and Loading Information label on the driver's doorjamb.

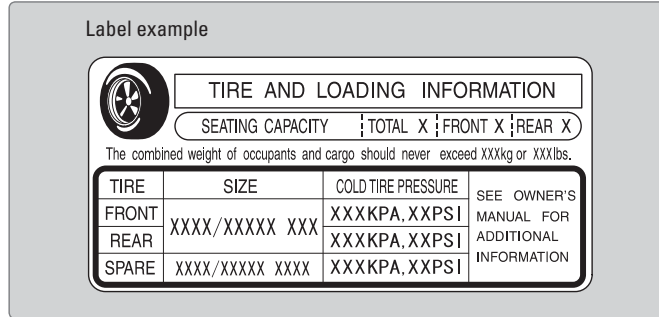

This figure includes the total weight of all occupants, cargo, and accessories, and the tongue load if you are towing a trailer. Below are the steps for determining the correct load limit:

1. Locate the statement "The combined weight of occupants and cargo should never exceed XXX kg or XXX lbs." on your vehicle's placard.
2. Determine the combined weight of the driver and passengers that will be riding in your vehicle.
3. Subtract the combined weight of the driver and passengers from XXX kg or XXX lbs.
4. The resulting figure equals the available amount of cargo and luggage load capacity. For example, if the "XXX" amount equals 1,400 lbs. and there will be five 150 lb. passengers in your vehicle, the amount of available cargo and luggage load capacity is 650 lbs. (1,400 - 750 (5 x 150) = 650 lbs.)
5. Determine the combined weight of luggage and cargo being loaded on the vehicle. That weight may not safely exceed the available cargo and luggage load capacity calculated in step 4.
6. If your vehicle will be towing a trailer, load from your trailer will be transferred to your vehicle. Consult the Owner's Manual on the Owner Information CD or at [owners.honda.com](http://owners.honda.com) (U.S.) or [myhonda.ca](http://myhonda.ca) (Canada) to determine how this reduces the available cargo and luggage load capacity of your vehicle.

In addition, the total weight of the vehicle, all occupants, accessories, cargo, and trailer tongue load must not exceed the Gross Vehicle Weight Rating (GVWR) or the Gross Axle Weight Rating (GAWR). Both are on a label on the driver's doorjamb.

### Load Limits Example

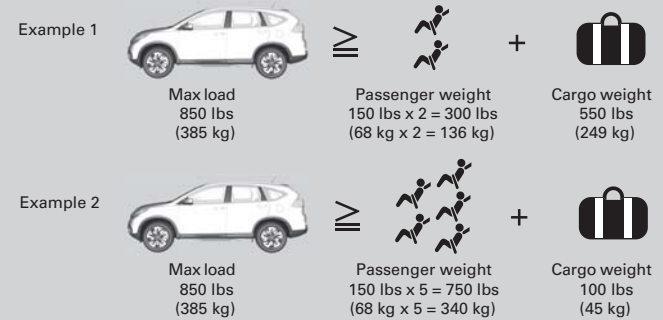

### WARNING

Overloading or improper loading can affect handling and stability and cause a crash in which you can be hurt or killed.

Follow all load limits and other loading guidelines in this guide.

The headlight aim on your vehicle was set by the factory, and does not need to be adjusted. However, if you regularly carry heavy items in the cargo area or pull a trailer, have the aiming readjusted at your dealer or by a qualified technician.



## Towing a Trailer

Your vehicle can tow a trailer if you carefully observe the load limits, use the proper equipment, and follow the towing guidelines. See the Owner's Manual on the Owner Information CD or at [owners.honda.com](http://owners.honda.com) (U.S.) or [www.myhonda.ca](http://www.myhonda.ca) (Canada) for more information.

### ■ Towing Load Limits

#### Total trailer weight

Maximum allowable weight of the trailer, cargo, and everything in or on it must not exceed 1,500 lbs (680 kg). Towing loads in excess of this can seriously affect vehicle handling and performance and can damage the engine and drivetrain.

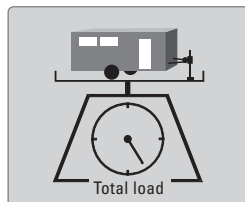

#### Tongue load

The weight of the tongue with a fully loaded trailer on the hitch should be approximately 10% of the total trailer weight.

- Excessive tongue load reduces front tire traction and steering control. Too little tongue load can make the trailer unstable and cause it to sway.
- To achieve a proper tongue load, start by loading 60% of the load toward the front of the trailer and 40% toward the rear. Readjust the load as needed.

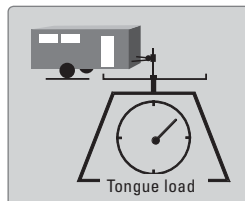

#### Pre-tow checklist

When preparing to tow, and before driving away, ensure the following:

- The vehicle has been properly serviced, and the suspension and the cooling system are in good operating condition.
- Avoid towing a trailer during your vehicle's first 600 miles (1,000 km).
- The trailer has been properly serviced and is in good condition.
- All weights and loads are within limits. Never exceed the gross weight ratings.
- Check if all loads are within limits at a public scale. If a public scale is not available, add the estimated weight of your cargo load to the weight of your trailer (as quoted by the manufacturer) and the tongue load.
- The hitch, safety chains, and any other attachments are secure.
- All items in or on the trailer are properly secured and cannot shift while you drive.

### ⚠ WARNING

Exceeding any load limit or improperly loading your vehicle and trailer can cause a crash in which you can be seriously hurt or killed.

Check the loading of your vehicle and trailer carefully before starting to drive.

## Starting to Drive

Turn on the vehicle and start the engine to begin driving.

### ■ Before Starting the Engine

Check that the shift lever is in Park (P), then press the brake pedal. Keep your foot firmly on the brake pedal when starting the engine.

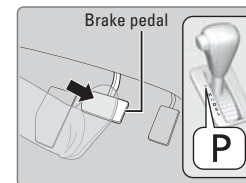

The engine is harder to start in cold weather and in thinner air found at altitudes above 8,000 feet (2,400 m). When starting the engine in cold weather, turn off all electrical accessories such as the lights, climate control system, and rear defogger in order to reduce battery drain.

### ■ Starting the Ignition\*

Insert the key into the ignition and turn to turn on the vehicle or start the engine.

🔒 **LOCK:** Insert and remove the key in this position.

🔊 **ACCESSORY:** Operate the audio system and other accessories in this position.

🚗 **ON:** This is the position when driving.

🔑 **START:** This position is for starting the engine.

The switch returns to ON when you release the key.

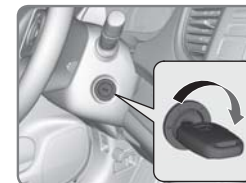

### ■ Changing the Power Mode\*

Use the ENGINE START/STOP button to cycle through power modes or start the engine.

**Accessory or On mode:** Press ENGINE START/STOP once without pressing the brake pedal for Accessory mode. Press it again for On mode.

**Starting the engine:** Press and hold the brake pedal, then press ENGINE START/STOP. Keep your foot firmly on the brake pedal when starting the engine.

**Turning the vehicle off:** Shift to Park (P), then press ENGINE START/STOP.

If you press the button and the shift lever is not in Park (P), the vehicle goes into Accessory mode.

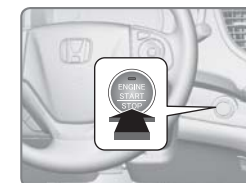

\*if equipped



## ■ Shifting

Change the shift position based on your driving needs.

**Park (P):** Used for parking or starting/stopping the engine. Press the brake pedal, then press the release button to shift.

**Reverse (R):** Used for reversing.

**Neutral (N):** Used for idling.

**Drive (D):** Used for normal driving.

**Drive (S):** Used for better acceleration, increased engine braking, or driving in hilly terrain.

**Low (L):** Used for stronger engine braking when driving in hilly terrain.

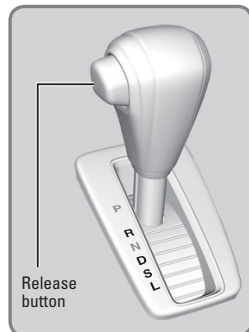

### NOTICE

When you change the shift lever from D to R and vice versa, come to a complete stop and keep the brake pedal depressed. Operating the shift lever before the vehicle has come to a complete standstill can damage the transmission.

Do not operate the shift lever while pressing the accelerator pedal. You could damage the transmission.

## Braking

Slow down or stop your vehicle, and keep it from moving when parked.

### ■ Foot Brake

Press the brake pedal to slow down or stop your vehicle from moving.

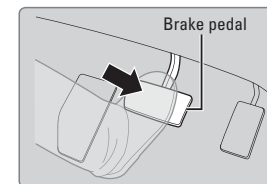

### ■ Parking Brake

Keep the vehicle from moving when it is parked.

**To apply:** Press the parking brake with your foot.

**To release:** Press the brake pedal, then press the parking brake until it releases.

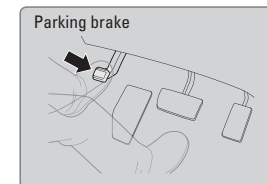

### NOTICE

Release the parking brake fully before driving. The rear brakes and axle can be damaged if you drive with the parking brake applied.

### ■ Brake Assist System

During hard or emergency braking, the system increases braking force. The brake pedal may move slightly or make a noise; this is normal. Continue to hold the brake pedal firmly down.

### ■ Anti-Lock Brake System (ABS)

During hard or emergency braking, the system rapidly pumps the brakes to prevent wheel lockup and help you maintain steering control. The brake pedal may pulsate slightly during ABS operation; this is normal. Do not pump the brake pedal, and continue to hold it firmly down.

### NOTICE

The ABS may not function correctly if you use an incorrect tire type and size.

## Vehicle Stability Assist (VSA®), aka Electronic Stability Control (ESC) System

Helps to stabilize the vehicle during cornering if the vehicle turns more or less than what was intended. It assists in maintaining traction on slippery surfaces by regulating engine output and selectively applying the brakes.

### ■ Turning VSA On or Off

VSA is turned on every time you start the engine, even if you previously turned it off. If you turn VSA off, your vehicle has normal braking and cornering ability, but not VSA traction and stability enhancement.

Press and hold the VSA OFF button until you hear a beep to turn VSA on or off. The VSA OFF indicator appears when the system is off.

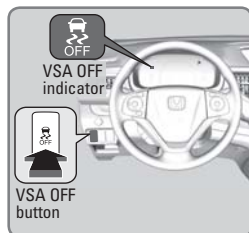

Traction control stops functioning, which may make it easier when trying to free your vehicle if it is stuck in mud or snow.

## Eco Assist System

Can help improve fuel economy by adjusting the performance of the engine, transmission, climate control system, and cruise control.

### ■ ECON Button

Press the ECON button to turn the system on or off. The ECON Mode indicator appears when the system is turned on.



### ■ Ambient Meter

Color-coded bars around the speedometer change based on your driving style and brake or accelerator pedal operation.

**Green:** Fuel efficient driving

**Light green:** Moderate acceleration/deceleration

**White:** Aggressive acceleration/deceleration

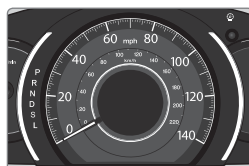

## Cruise Control\*

Maintain a constant vehicle speed without having to keep your foot on the accelerator pedal. Use cruise control on freeways or open roads where you can travel at a constant speed with little acceleration or deceleration.

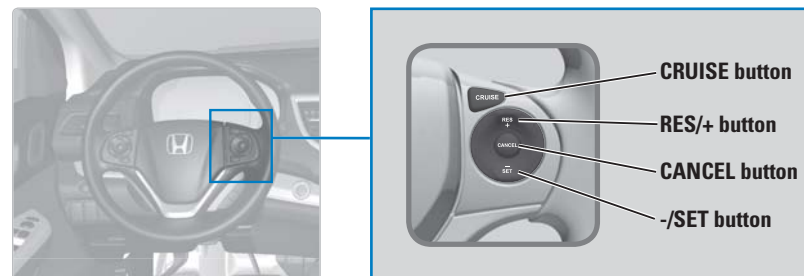

### ■ Activating and Setting the Vehicle Speed

1. Press CRUISE. The CRUISE MAIN indicator appears.
2. Accelerate to the desired speed (above 25 mph/40 km/h). Press -/SET and take your foot off the pedal to set the speed. The CRUISE CONTROL indicator appears.

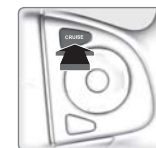

### ■ Adjusting the Vehicle Speed

Press RES/+ to increase or -/SET to decrease.

Each time you press the button, the vehicle speed is increased or decreased by about 1 mph (1.6 km/h). If you keep the button pressed, the vehicle speed increases or decreases by 5 mph (5 km/h) until you release it.



### ■ Canceling Cruise Control

Press CANCEL or the brake pedal. The CRUISE CONTROL indicator goes off.

After cruise control has been canceled, you can still resume the prior set speed by pressing RES/+ while driving at a speed of at least 25 mph (40 km/h).

Press CRUISE to turn the system off.



## ⚠ WARNING

Improper use of the cruise control can lead to a crash.

Use cruise control only when traveling on open highways in good weather.

\*if equipped

## Adaptive Cruise Control (ACC)\*

Helps maintain a constant vehicle speed and a set following distance behind a vehicle detected in front of yours. When the vehicle ahead changes speed, ACC senses the change and accelerates or decelerates to maintain a set distance.

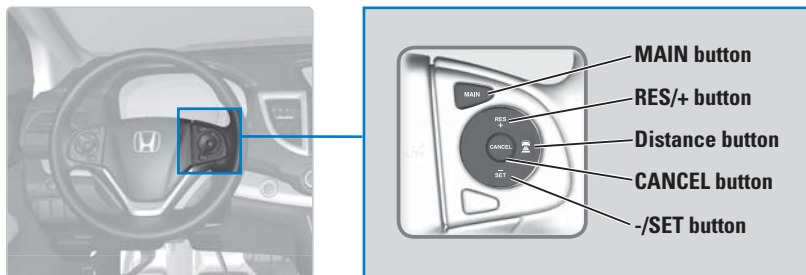

### ■ Activating and Setting the Vehicle Speed

1. Press MAIN. The ACC indicator appears on the MID.
2. Accelerate to the desired speed (above 25 mph/ 40 km/h). Press -/SET and take your foot off the pedal to set the speed. The ACC display appears on the MID.



### ■ Adjusting the Vehicle Speed

Press RES/+ to increase or -/SET to decrease.

Each time you press the button, the vehicle speed is increased or decreased by about 1 mph (1.6 km/h). If you keep the button pressed, the vehicle speed increases or decreases by 5 mph (5 km/h) until you release it.



### ■ Adjusting the Following Distance

Press the Distance button to change the following distance. Each time you press the button, the following distance setting cycles through short, middle, long, and extra long following distances.



### ■ Switching to Standard Cruise Control

Press and hold the Distance button. CRUISE MODE SELECTED appears on the MID.

### ■ During Operation

When there is no vehicle ahead of you, your vehicle cruises at the set speed.

When there is a vehicle ahead of you, your vehicle maintains the following range selected with the Distance button by increasing or decreasing your vehicle's speed.

If a vehicle ahead of you slows down abruptly or another vehicle cuts in front of you, a beep sounds and a message appears on the MID alerting you to brake.

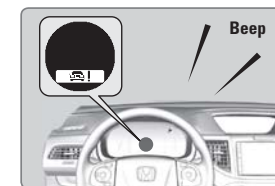

### ⚠ WARNING

ACC has limited braking capability. When your vehicle speed drops below 22 mph, ACC automatically cancels and no longer applies your vehicle's brakes. Always be prepared to apply the brake pedal if the conditions require.

### ■ Canceling ACC

Press CANCEL or MAIN, or press the brake pedal. The ACC indicator goes off.

Certain conditions may cause ACC to cancel automatically. When this happens, a beep sounds and a message appears on the MID.

After ACC has been canceled, you can still resume the prior set speed by pressing RES/+ while driving at a speed of at least 25 mph (40 km/h).

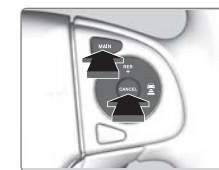

\*if equipped

## Lane Departure Warning (LDW)\*

A camera mounted between the windshield and the rearview mirror determines if your vehicle begins to move away from the center of a detected lane while driving between 45–90 mph (72–145 km/h).

If you cross a detected lane line without using your turn signal, a message appears on the display and a beep sounds.

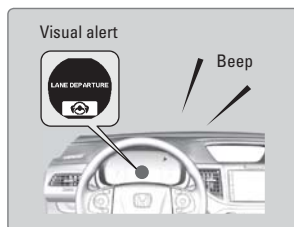

### Turning LDW On or Off

Press LDW to turn the system on or off. A green indicator light appears on the button when the system is on.

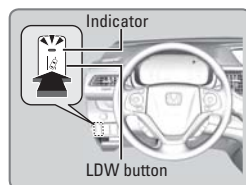

### Important Safety Reminder

Like all assistance systems, LDW has limitations. Over-reliance on LDW may result in a collision. It is always your responsibility to keep the vehicle within your lane.

LDW only alerts you when lane drift is detected without a turn signal in use. LDW may not detect all lane markings or lane departures; accuracy will vary based on weather, speed, and lane marker condition. It is always your responsibility to safely operate the vehicle and avoid collisions.

\*if equipped

## Lane Keeping Assist System (LKAS)\*

A camera mounted between the windshield and the rearview mirror determines if your vehicle begins to move away from the center of a detected lane while driving between 45–90 mph (72–145 km/h).

If you cross a detected lane line without using your turn signal, a message appears on the MID and a beep sounds.

Steering wheel vibrations alert you to steer your vehicle back to the middle of the lane.

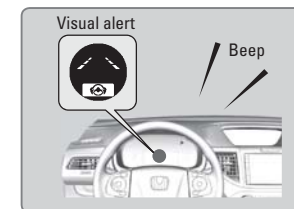

### Turning LKAS On or Off

1. Press MAIN. LKAS appears in the MID.

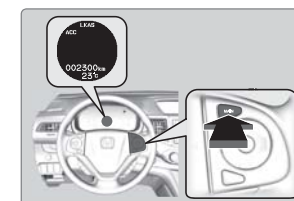

2. Press the LKAS button. Lane outlines appear in the MID. Dotted lane lines turn solid when the system operates.

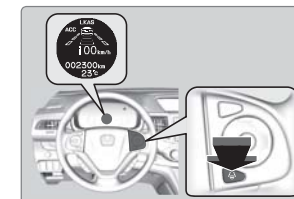

3. Press MAIN or the LKAS button to turn the system off.

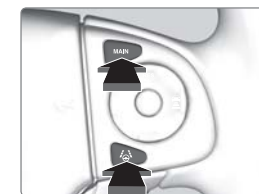

### Important Safety Reminder

The LKAS is for your convenience only. It is not a substitute for your vehicle control. The system does not work if you take your hands off the steering wheel or fail to steer the vehicle.

Do not place an object on the top of the instrument panel. It may reflect onto the windshield and prevent the system from detecting lane lines properly.

\*if equipped

## Collision Mitigation Braking System™ (CMBS™)\*

Can alert you when a potential frontal collision with a vehicle or pedestrian is determined and reduce your vehicle speed when a collision is deemed unavoidable to help minimize collision severity.

The system provides visual and audible alerts if you do not take appropriate action to avoid a collision.

### ■ Alert Stages

The system has three alert stages for a possible collision. Depending on the circumstances or CMBS settings, CMBS may not go through all of the stages before initiating the last stage.

**Stage 1:** Visual warnings and audible warning

**Stage 2:** Visual warnings, audible warning, and light brake application

**Stage 3:** Visual warnings, audible warning, and strong brake application

### ■ Turning CMBS On or Off

Press and hold the CMBS OFF button. A beep sounds and a message appears in the MID. The CMBS indicator appears when the system is off.

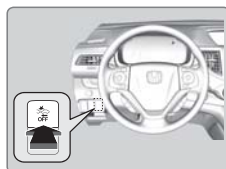
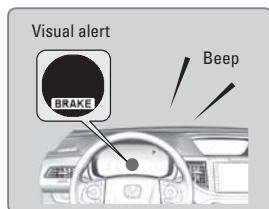

### ■ Changing Settings

Change the alert distance. Use the steering wheel buttons to make and enter selections in the MID (see page 30).

1. Select the Customize Settings display.
2. Select Change Settings.
3. Select Driver Assist System Setup.
4. Select Forward Collision Warning Distance. Select Long, Normal, or Short.
5. Exit the menu.

### Important Safety Reminder

CMBS is designed to reduce the severity of an unavoidable collision. It does not prevent collision nor stop the vehicle automatically. It is still your responsibility to operate the brake pedal and steering wheel appropriately according to the driving conditions.

\*if equipped

## LaneWatch™\*

Check the passenger-side rear areas in the upper display when the right turn signal is activated.

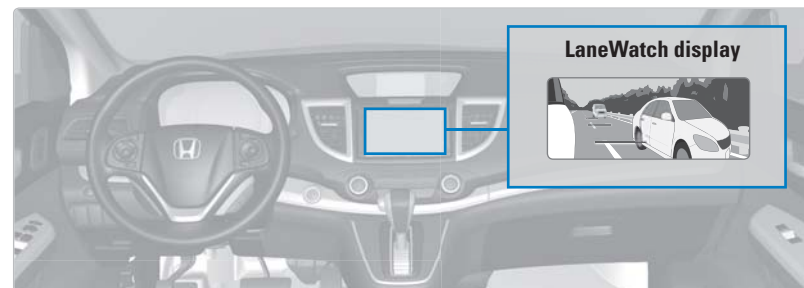

### ■ Activating LaneWatch

Activate the right turn signal. The LaneWatch display appears. Check the display for blind spots, and visually confirm that it is safe to change lanes.

You can also press the LaneWatch button on the end of the turn signal switch to view a constant real-time display. Press it again to turn the display off.

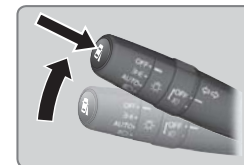

### ■ Changing Settings

Customize the display and how and when the display appears.

1. From the HOME screen, select Settings.
2. Select Camera.
3. Select LaneWatch.
4. Select an option and make the preferred changes.
5. Press BACK to exit the menu.



### Important Safety Reminder

Like all assistance systems, LaneWatch has limitations. Over-reliance on the system may result in a collision.

## ⚠ WARNING

Failure to visually confirm that it is safe to change lanes before doing so may result in a crash and serious injury or death.

Do not rely only on LaneWatch while driving. Always look in your mirrors, to either side of your vehicle, and behind you for other vehicles before changing lanes.

\*if equipped

## Multi-View Rear Camera\*

When you shift into Reverse (R), a real-time image of the area behind your vehicle is shown in the i-MID, along with helpful parking guidelines.

### Models with one display

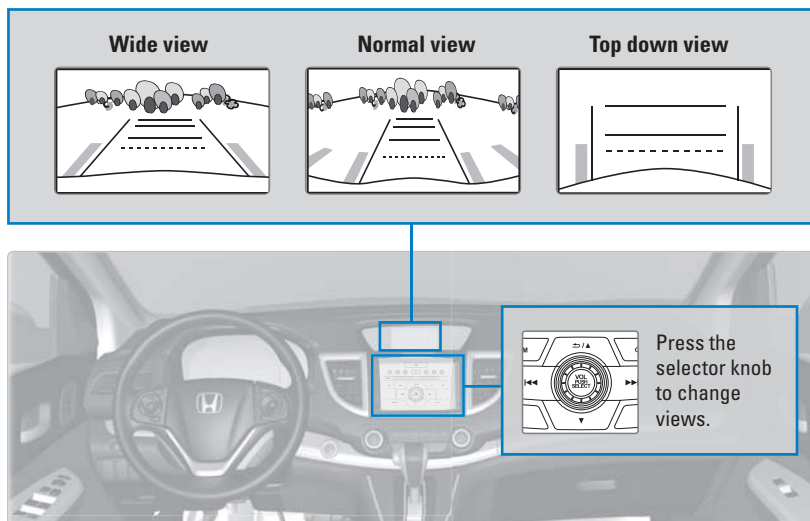

*The rear camera view is restricted. You cannot see the corner ends of the bumper or what is underneath the bumper. Its unique lens also makes objects appear closer or farther than they actually are.*

*Visually confirm that it is safe to drive before backing up. Certain conditions (such as weather, lighting, and high temperatures) may also restrict the rear view. Do not rely on the rearview display, which does not give you all information about conditions at the rear of your vehicle.*

\*if equipped

## Multi-View Rear Camera\*

When you shift into Reverse (R), a real-time image of the area behind your vehicle is shown in the touchscreen, along with helpful parking guidelines.

### Models with touchscreen

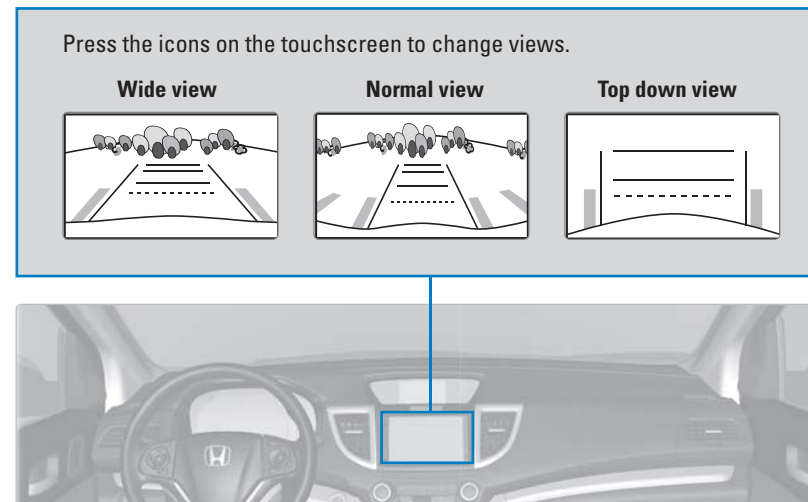

### ■ Changing Camera Settings

Turn the guidelines on or off.

1. From the HOME screen, select Settings.
2. Select Camera.
3. Select Rear Wide Camera.
4. Select one of the options.

*Fixed Guideline:* Guidelines appear when you shift into Reverse. Select On or Off.

*Dynamic Guideline:* Guidelines move as you turn the steering wheel. Select On or Off.

5. Press BACK to exit the menu.

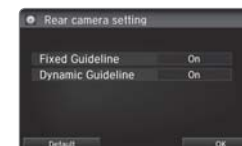

*The rear camera view is restricted. You cannot see the corner ends of the bumper or what is underneath the bumper. Its unique lens also makes objects appear closer or farther than they actually are.*

*Visually confirm that it is safe to drive before backing up. Certain conditions (such as weather, lighting, and high temperatures) may also restrict the rear view. Do not rely on the rearview display, which does not give you all information about conditions at the rear of your vehicle.*

\*if equipped



## Refueling

Use the proper fuel and refueling procedure to ensure the best performance and safety of your vehicle.

### Fuel Information

**Use of unleaded gasoline of 87 octane or higher is recommended.**

- Honda recommends TOP TIER Detergent Gasoline where available.
- Do NOT use gasoline containing more than 15% ethanol.
- Do NOT use gasoline containing methanol.
- Do NOT use gasoline containing MMT.

### NOTICE

We recommend quality gasoline containing detergent additives that help prevent fuel system and engine deposits. In addition, in order to maintain good performance, fuel economy, and emissions control, we strongly recommend the use of gasoline that does NOT contain harmful manganese-based fuel additives such as MMT, if such gasoline is available.

### How to Refuel

1. The fuel fill door is located at the left rear of the vehicle. Park next to the service pump that is most accessible.
2. Turn off the engine.
3. Pull the fuel fill door release handle near the parking brake. The fuel fill door opens.
4. Turn the fuel fill cap slowly to open. Place the fuel fill cap in the holder.
5. Insert the filler nozzle fully. When the tank is full, the fuel nozzle clicks off automatically.
6. Replace the fuel fill cap. Tighten it until you hear at least one click. Close the fuel fill door.



### ⚠ WARNING

Gasoline is highly flammable and explosive. You can be burned or seriously injured when handling fuel.

- Stop the engine, and keep heat, sparks, and flame away.
- Handle fuel only outdoors.
- Wipe up spills immediately.

## HANDLING THE UNEXPECTED

Learn about what to do in critical or emergency situations.

### Smart Entry Remote Battery Strength\*

If the battery life in your remote transmitter is weak, a message appears in the display with information on how to start the engine.

1. Touch the back of the remote transmitter to the ENGINE START/STOP button while the indicator is flashing.
2. With the brake pedal pressed, press the ENGINE START/STOP button within 10 seconds.

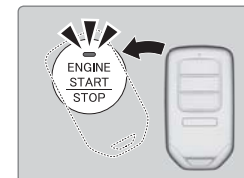

### Jump Starting

Turn off the power to electric devices, such as audio and lights. Turn off the engine, then open the hood.

1. Connect the first jumper cable to your vehicle's battery (+) terminal.
2. Connect the other end of the first jumper cable to the booster battery (+) terminal. Use a 12-volt booster battery only.
3. Connect the second jumper cable to the booster battery (-) terminal.
4. Connect the other end of the second jumper cable to the engine mounting bolt as shown. Do not connect this jumper cable to any other part.
5. If your vehicle is connected to another vehicle, start the assisting vehicle's engine and increase its rpm slightly.
6. Attempt to start your vehicle's engine. If it turns over slowly, make sure that the jumper cables have good metal-to-metal contact.

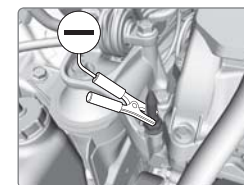
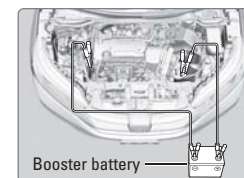

### ⚠ WARNING

A battery can explode if you do not follow the correct procedure, seriously injuring anyone nearby.

Keep all sparks, open flames, and smoking materials away from the battery.

\*if equipped

### ■ After the Engine Starts

Once your vehicle's engine has started, remove the jumper cables in the following order:

1. Disconnect the jumper cable from your vehicle's ground.
2. Disconnect the other end of the jumper cable from the assisting vehicle's (-) terminal.
3. Disconnect the jumper cable from your vehicle's (+) terminal.
4. Disconnect the other end of the jumper cable from the assisting vehicle's (+) terminal.
5. Have your vehicle inspected by a nearby service station or a dealer.

### Shift Lever Does Not Move

Follow the procedure below if you cannot move the shift lever out of Park (P).

1. Set the parking brake.
2. Remove the key from the ignition, or remove the built-in key from the remote transmitter.
3. Wrap a cloth around the tip of a small flat-tip screwdriver to remove the cover of the shift lock release slot. Put the tip of the flat-tip screwdriver into the slot and remove it as shown in the image.
4. Insert the key into the shift lock release slot.
5. While pushing the key down, press the shift lever release button and place the shift lever into Neutral (N). The lock is now released. Have the shift lever checked by a dealer as soon as possible.

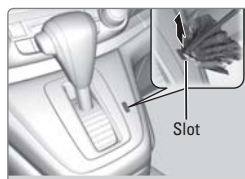

### Overheating

If the temperature gauge needle is at the H mark, the engine suddenly loses power, or steam or spray comes out from under the hood, your engine is overheating.

1. Immediately park the vehicle in a safe place. Turn off all accessories and turn on the hazard warning lights.
2. *If steam or spray is not present:* Keep the engine running and open the hood.



*If steam or spray is present:* Turn off the engine and wait until it subsides. Then, open the hood.

3. Check that the cooling fan is operating and stop the engine once the temperature gauge needle comes down. If the cooling fan is not operating, immediately stop the engine.
4. Once the engine has cooled down, inspect the coolant level and check the cooling system components for leaks. If the coolant level in the reserve tank is low, add coolant until it reaches the MAX mark. If there is no coolant in the reserve tank, make sure the radiator is cool, then cover the radiator cap with a heavy cloth and open the cap. If necessary, add coolant up to the base of the filler neck, and put the cap back on.

Once the engine has cooled sufficiently, restart it and check the temperature gauge. If the temperature needle has gone down, resume driving. If it has not gone down, contact a dealer for repairs.

#### ⚠ WARNING

Steam and spray from an overheated engine can seriously scald you.  
Do not open the hood if steam is coming out.

#### ⚠ WARNING

Removing the radiator cap while the engine is hot can cause the coolant to spray out, seriously scalding you.  
Always let the engine and radiator cool down before removing the radiator cap.

#### NOTICE

Continuing to drive with the temperature gauge needle at the H mark may damage the engine.

## Emergency Engine Stop\*

The ENGINE START/STOP button may be used to stop the engine due to an emergency situation even while driving. If you must stop the engine, choose one of the following operations:

- Press and hold the ENGINE START/STOP button for two seconds, or
- Firmly press the ENGINE START/STOP button two times.



The steering wheel will not lock. The power mode changes to ACCESSORY, unless the shift lever is in Park (P), in which case the power mode changes to VEHICLE OFF.

Because turning off the engine also disables the power assist the engine provides to the steering and braking systems, it will require significantly more physical effort and time to steer and slow the vehicle. Downshift gears and use both feet on the brake pedal, if necessary, to slow the vehicle and stop immediately in a safe place.

Do not press the button while driving unless it is absolutely necessary for the engine to be switched off.

## Emergency Towing

Call a professional towing service if you need to tow your vehicle.

Flat bed equipment: The operator loads your vehicle on the back of a truck. **This is the best way to transport your vehicle.**

Wheel lift equipment: The tow truck uses two pivoting arms that go under the front tires and lift them off the ground. The rear tires remain on the ground. **This is an acceptable way to tow your vehicle (2WD models only).**

### NOTICE

Trying to lift or tow your vehicle by the bumpers will cause serious damage. The bumpers are not designed to support the vehicle's weight.

Improper towing such as towing behind a motorhome or other motor vehicle can damage the transmission.

\*if equipped

## Tire Pressure Monitoring System (TPMS)

Monitors the tire pressure while you are driving.

If your vehicle's tire pressure becomes significantly low, the low tire pressure indicator comes on and a message appears on the multi-information display.



### ■ What to Do

Stop your vehicle in a safe place. Check the tire pressure and adjust the pressure to the specified level. The specified tire pressure is on a label on the driver's doorjamb.

### ■ TPMS Calibration

Any time you inflate, change, or rotate one of more of the tires, you need to recalibrate the system.

#### On vehicles with information display

Press and hold the TPMS button on the dashboard. The TPMS indicator blinks, and calibration begins.

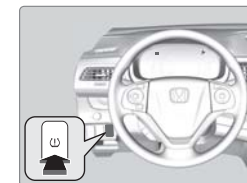

#### On vehicles with multi-information display (MID)

Use the buttons on the steering wheel to enter and operate the Vehicle Settings menu (see page 30).

1. Scroll to the Vehicle Settings screen and enter the menu.
2. Select TPMS Calibration.
3. Select Calibrate. Calibration begins.
4. Exit the menu.

### NOTICE

Driving on an extremely underinflated tire can cause it to overheat. An overheated tire can fail. Always inflate your tires to the specified pressure.

## Changing a Flat Tire

If a tire goes flat while driving, grasp the steering wheel firmly, and brake gradually to reduce speed. Then, stop in a safe place. Replace the flat tire with the compact spare tire. Go to a dealer as soon as possible to have the full-size tire repaired or replaced.

### ■ Getting Ready to Change the Tire

Park the vehicle on a firm, level, non-slippery surface. Apply the parking brake, shift to Park (P), and turn the vehicle off. Turn on the hazard warning lights.

1. Open the tailgate. Turn on the cargo lights if necessary (see page 39).
2. Open the cargo area floor lid.
3. Take the tool bag out of the cargo area. Take the jack handle bar and wheel nut wrench out of the tool bag.
4. Take the jack out of the spare tire area.
5. Unscrew the wing bolt and remove the spacer cone. Then remove the spare tire.
6. Place a wheel block or rock in front and rear of the wheel diagonal to the flat tire.
7. Place the compact spare tire (wheel side up) under the vehicle body, near the tire that needs to be replaced.
8. Loosen each wheel nut about one turn using the wheel nut wrench.



### ■ Setting Up the Jack

1. Place the jack under the jacking point closest to the tire to be changed.
2. Turn the end bracket clockwise (as shown in the image) until the top of the jack contacts the jacking point. Make sure that the jacking point tab is resting in the jack notch.
3. Raise the vehicle, using the jack handle bar and the jack handle, until the tire is off the ground.

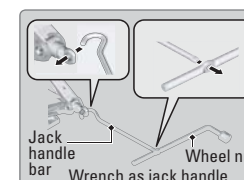
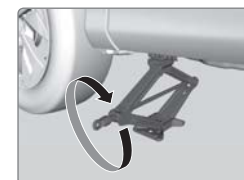
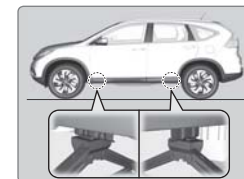

### ⚠ WARNING

The vehicle can easily roll off the jack, seriously injuring anyone underneath. Follow the directions for changing a tire exactly, and never get under the vehicle when it is supported only by the jack.

The following instructions must be followed to use the jack safely:

- Do not use the jack with people or luggage in the vehicle.
- Use the jack provided in your vehicle. Other jacks may not support the weight ("load") or fit the jacking point.
- Do not use while the engine is running.
- Use only where the ground is firm and level.
- Use only at the jacking points.
- Do not get in the vehicle while using the jack.
- Do not put anything on top of or underneath the jack.

**■ Replacing the Flat Tire**

1. Remove the wheel nuts and flat tire.
2. Mount the compact spare tire. Replace the wheel nuts, and lightly tighten them.
3. Lower the vehicle and remove the jack. Tighten the wheel nuts in the order indicated in the image. Go around, tightening the nuts, two to three times in this order. Do not overtighten the wheel nuts.

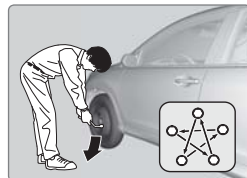
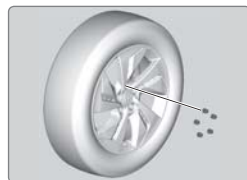

If you drive with the spare tire installed, the low tire pressure/TPMS indicator appears. The indicator stays on until a regular tire is installed.

**■ Storing the Flat Tire**

1. Remove the center cap.
2. Place the flat tire face down in the spare tire well.
3. Remove the spacer cone from the wing bolt, flip it over, and insert it back on the bolt. Secure the flat tire with the wing bolt.
4. Securely store the wheel nut wrench and jack handle bar back in the tool bag. Store the bag in the cargo area.
5. Store the jack in its holder. Turn the jack's end bracket to lock it in place.

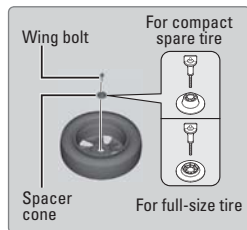

**⚠ WARNING**

Loose items can fly around the interior in a crash and can seriously injure the occupants.

Store the wheel, jack, and tools securely before driving.

**Fuse Locations**

If any electrical devices are not working, turn the vehicle off and check to see if any applicable fuse is blown. Fuse locations are shown on the fuse box cover. Locate the fuse in question by the fuse number and box cover number.

**■ Engine Compartment Fuse Box**

Located under the hood near the brake fluid reservoir. Push the tabs to open the box.

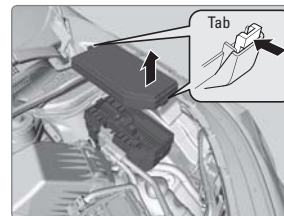

	Circuit Protected	Amps
1	EPS	70 A
	Power Tailgate	(40 A)
	ABS/VSA FSR	20 A
	ABS/VSA Motor	40 A
	E-DPS*	(30 A)
	Main Fuse	120 A
	Main	50 A
	Fuse Box Main	60 A
	Fuse Box Main 2	60 A
	Headlight High Beam Main	30 A
2	ST Magnetic Switch	(30 A)
	Rear Defogger	30 A
	-	-
	Heater Motor	40 A
3	Front Wiper Main	30 A
	Sub Fan Motor	20 A
	Main Fan Motor	20 A
	DC/DC1	(30 A)
	DC/DC2	(30 A)
4	IG MAIN	(30 A)
	IG MAIN2	(30 A)
5	-	-
6	-	-
7	-	-

	Circuit Protected	Amps
8	Sub Fan Rly CL	7.5 A
9	VSA ECU	7.5 A
10	Heated Door Mirror*	(7.5 A)
11	STRLD	7.5 A
12	Injector	20 A
13	Premium Amp*	(20 A)
14	Horn	10 A
15	Hazard	10 A
16	Stop	10 A
17	IG Coil	15 A
18	IGP2	15 A
19	Daytime Running Lights	(10 A)
20	Passenger's Power Seat Reclining	(20 A)
21	Deicer	(15 A)
22	DBW	15 A
23	IGP	15 A
24	Left Headlight Low Beam	10 A
25	Right Headlight Low Beam	10 A
26	SMALL	20 A
27	MG Clutch	7.5 A
28	Interior Lights	7.5 A
29	Backup	10 A

\*if equipped

■ Interior Fuse Box

Located under the dashboard.

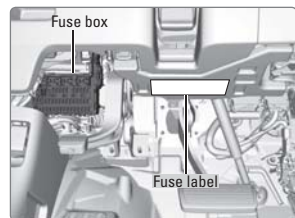

	Circuit Protected	Amps
1	-	-
2	ACG	10 A
3	SRS	10 A
4	Fuel Pump	15 A
5	Meter	10 A
6	Power Window	7.5 A
7	VB SOL	7.5 A
8	Passenger's Side Door Lock Motor 2 (Unlock)	15 A
9	Driver's Side Door Lock Motor 1 (Unlock)	15 A
10	Trailer*	(7.5 A)
11	Moonroof*	(20 A)
12	Accessory Power Socket (Center Console)	20 A
13	Washer Main*	(15 A)
14	Seat Heaters*	(20 A)
15	Driver's Door Lock Motor (Unlock)	10 A
16	Driver's Power Seat Sliding*	(20 A)
17	Driver's Power Seat Reclining*	(20 A)
18	-	-
19	ACC	7.5 A

	Circuit Protected	Amps
20	ACC Key Lock	7.5 A
21	Daytime Running Lights	7.5 A
22	A/C	7.5 A
23	Wiper	10 A
24	ABS/VSA	7.5 A
25	Audio	10 A
26	Power Tailgate*	(20 A)
27	Accessory Power Socket (Front)	20 A
28	Washer*	15 A
29	OPDS	7.5 A
30	Driver's Door Lock Motor (Lock)	10 A
31	Smart*	(10 A)
32	Passenger's Side Door Lock Motor 2 (Lock)	15 A
33	Driver's Side Door Lock Motor 1 (Lock)	15 A
34	Small Lights	10 A
35	Illumination	7.5 A
36	Rear Wiper Main*	(10 A)
37	Front Fog Lights*	(20 A)
38	Left Headlight High Beam	10 A
39	Right Headlight High Beam	10 A
40	-	-
41	Door Lock	20 A
42	Driver's Side Power Window	20 A
43	Rear Passenger's Side Power Window	20 A
44	Front Passenger's Side Power Window	20 A
45	Rear Driver's Side Power Window	20 A
46	-	-

\*if equipped

■ Inspecting and Changing Fuses

1. Turn the vehicle off, including all lights and accessories.
2. Remove the fuse box cover.
3. Check the large fuse in the engine compartment.

If the fuse is blown, use a Phillips-head screwdriver to remove the screws and replace the fuse with a new one. Reinstall the screws.

4. Inspect the small fuses in the engine compartment and the vehicle interior.

If there is a burned-out fuse, remove it with the fuse puller and replace it with a new one.

**NOTICE**

Replacing a fuse with one that has a higher rating greatly increases the chances of damaging the electrical system.

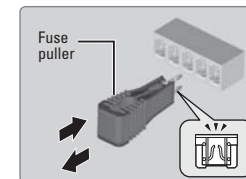
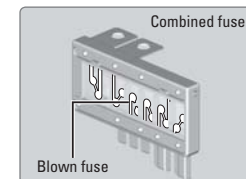



# MAINTENANCE

Learn about basic maintenance that you can perform on the vehicle yourself, as well as information about how to best maintain the vehicle.

## Safety Precautions

Some of the most important safety precautions are listed below; however, we cannot warn you of every conceivable hazard that can arise in performing maintenance. Only you can decide whether or not you should perform a given task.

### ■ Maintenance Safety

- To reduce the possibility of fire or explosion, keep cigarettes, sparks, and flames away from the battery and all fuel-related parts.
- Never leave rags, towels, or other flammable objects under the hood.
- To clean parts, use a commercially available degreaser or parts cleaner, not gasoline.
- Wear eye protection and protective clothing when working with the battery or compressed air.
- Do not run the engine in confined spaces where carbon monoxide gas can accumulate.

### ■ Vehicle Safety

- The vehicle must be stationary, and parked on level ground with the parking brake set and the engine off.
- Be aware that hot parts can burn you.
- Be aware that moving parts can injure you.

### ⚠️ WARNING

Improperly maintaining this vehicle or failing to correct a problem before driving can cause a crash in which you can be seriously hurt or killed.

Always follow the inspection and maintenance recommendations according to the schedules in this guide.

### ⚠️ WARNING

Failure to properly follow maintenance instructions and precautions can cause you to be seriously hurt or killed.

Always follow the procedures and precautions in this guide.

## Maintenance Minder™

Reminds you when indicated maintenance service is due.

### Models with information display

When maintenance is due, the Maintenance Minder indicator comes on and a message appears on the display every time you turn the vehicle on. Press the select/reset knob to change displays.

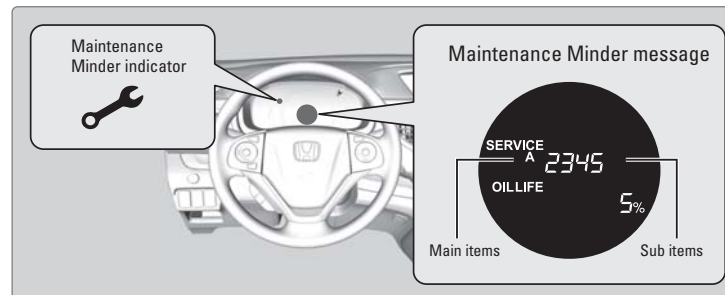

### Models with multi-information display

When maintenance is due, the system message indicator comes on and a message appears on the display every time you turn the vehicle on. Press the Info button on the steering wheel to change displays.

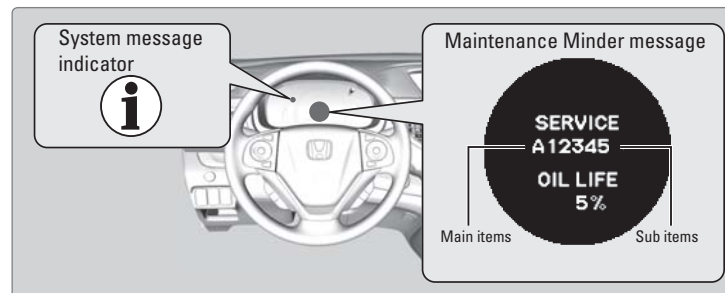

- Independent of the Maintenance Minder information, replace the brake fluid every 3 years.
- Inspect idle speed every 160,000 miles (256,000 km).
- Adjust the valves during services A, B, 1, 2, or 3 if they are noisy.

TABLE OF CONTENTS

VISUAL INDEX

SAFETY INFORMATION

INSTRUMENT PANEL

VEHICLE CONTROLS

AUDIO AND CONNECTIVITY

BLUETOOTH® HANDSFREE LINK®

HONDALINK®

NAVIGATION

DRIVING

HANDLING THE UNEXPECTED

MAINTENANCE

SPECIFICATIONS

CUSTOMER INFORMATION

VOICE COMMAND INDEX

INDEX

**Maintenance Minder Service Codes**

These codes indicate what services are due on your vehicle.

CODE	Maintenance Main Items
A	Replace engine oil *1
B	Replace engine oil *1 and oil filter Inspect front and rear brakes Check parking brake adjustment Inspect tie rod ends, steering gearbox, and boots Inspect suspension components Inspect driveshaft boots Inspect brake hoses and lines (Including ABS/VSA) Inspect all fluid levels and condition of fluids Inspect exhaust system # Inspect fuel lines and connections #

\*1: If a message SERVICE does not appear more than 12 months after the display is reset, change the engine oil every year.

#: See information on maintenance and emissions warranty.

CODE	Maintenance Sub Items
1	Rotate tires
2	Replace air cleaner element *2 Replace dust and pollen filter *3 Inspect drive belt
3	Replace transmission fluid *4
4	Replace spark plugs Inspect valve clearance
5	Replace engine coolant
6	Replace rear differential fluid *

\*2: If you drive in dusty conditions, replace the air cleaner element every 15,000 miles (24,000 km).

\*3: If you drive primarily in urban areas that have high concentrations of soot in the air from industry and diesel-powered vehicles, replace the dust and pollen filter every 15,000 miles (24,000 km).

\*4: Driving in mountainous areas at very low vehicle speeds or trailer towing results in higher transmission temperatures. This requires transmission fluid changes more frequently than recommended by the Maintenance Minder. If you regularly drive your vehicle under these conditions, have the transmission fluid changed every 25,000 miles (40,000 km).

**U.S. Models**

**Maintenance, replacement, or repair of emissions control devices and systems may be done by any automotive repair establishment or individuals using parts that are certified to EPA standards.**

According to state and federal regulations, failure to perform maintenance on the maintenance main items marked with # will not void your emissions warranties. However, all maintenance services should be performed in accordance with the intervals indicated by the multi-information display.

**Under the Hood**

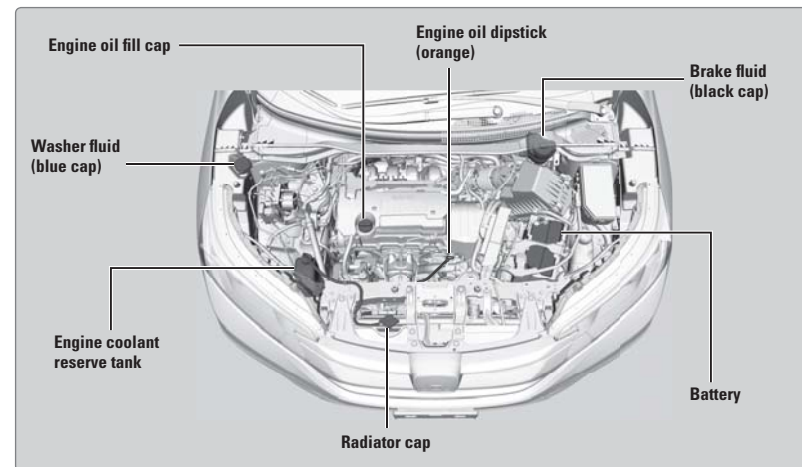

**Opening the Hood**

1. Park the vehicle on a level surface, and set the parking brake.
2. Pull the hood release handle under the lower left corner of the dashboard.
3. Push up the hood latch lever in the center of the hood to release the lock mechanism, and open the hood.
4. Remove the support rod from the clamp using the grip. Mount the support rod in the hood.

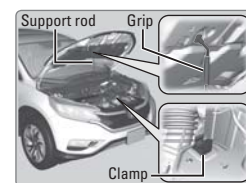
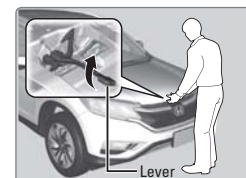

When closing, remove the support rod, and stow it in the clamp, then gently lower the hood. Remove your hand at a height of approximately 12 inches (30 cm) and let the hood close.

**NOTICE**

Do not open the hood when the wiper arms are raised. The hood will strike the wipers, and may damage either the hood or the wipers.

## Engine Oil

Park the vehicle on level ground, and wait approximately three minutes after turning the engine off before you check the oil.

### ■ Checking the Oil

1. Remove the dipstick (orange loop).
2. Wipe the dipstick with a clean cloth or paper towel.
3. Insert the dipstick back all the way into its hole.
4. Remove the dipstick again, and check the level. It should be between the upper and lower marks. Add oil if necessary.

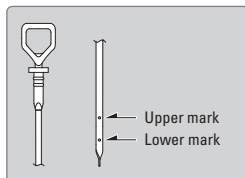
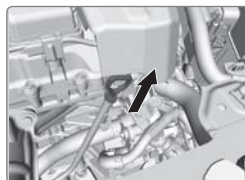

### ■ Recommended Engine Oil

- **Honda Genuine Motor Oil**
- **Premium-grade 0W-20 detergent oil with an API Certification Seal on the container**

This seal indicates the oil is energy conserving and that it meets the American Petroleum Institute's latest requirements.



Use Honda Genuine Motor Oil or another commercial engine oil of suitable viscosity for the ambient temperature as shown.

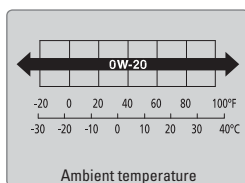

You may also use synthetic motor oil if it is labeled with the API Certification Seal and is of the specified viscosity grade.

### ■ Adding Oil

1. Unscrew and remove the engine oil fill cap.
2. Add oil slowly.
3. Reinstall the engine oil fill cap, and tighten it securely.
4. Wait for three minutes and recheck the engine oil dipstick.

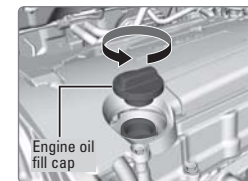

### NOTICE

Do not fill the engine oil above the upper mark. Overfilling the engine oil can result in leaks and engine damage.

### ■ Resetting the Engine Oil Life

If you change or replace the vehicle's engine oil yourself, you must reset the engine oil life. Use the buttons on the steering wheel to operate the Vehicle Menu (see page 31).

1. Press MENU.
2. Select Maintenance Info.
3. Press the SOURCE button to enter reset mode. Select Yes. The maintenance codes disappear, and the engine oil life display returns to 100%.



### NOTICE

Failure to reset the engine oil life after a maintenance service results in the system showing incorrect maintenance intervals, which can lead to serious mechanical problems.

## Engine Coolant

Park the vehicle on level ground. Check the reserve tank and the coolant level in the radiator. **We recommend Honda Long Life Antifreeze/Coolant Type 2.**

### ■ Checking the Reserve Tank

1. Check the amount of coolant in the reserve tank.
2. If the coolant level is below the MIN mark, add the specified coolant until it reaches the MAX mark.
3. Inspect the cooling system for leaks.

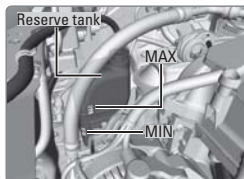

### NOTICE

If temperatures consistently below  $-22^{\circ}\text{F}$  ( $-30^{\circ}\text{C}$ ) are expected, the coolant mixture should be changed to a higher concentration. Consult a dealer for details for more information.

### ■ Adding Coolant

1. Make sure the engine and radiator are cool.
2. Turn the radiator cap counterclockwise and relieve any pressure in the coolant system. Do not push the cap down when turning.
3. Push down and turn the radiator cap counterclockwise to remove it.
4. The coolant level should be up to the base of the filler neck. Add coolant if it is low.
5. Put the radiator cap back on, and tighten it fully.
6. Pour coolant into the reserve tank until it reaches the MAX mark. Put the cap back on the reserve tank.

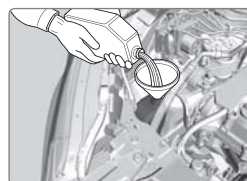
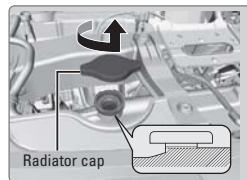

### ⚠ WARNING

Removing the radiator cap while the engine is hot can cause the coolant to spray out, seriously scalding you.

Always let the engine and radiator cool down before removing the radiator cap.

### NOTICE

Pour the fluid slowly and carefully so you do not spill any. Clean up any spills immediately; they can damage components in the engine compartment.

## Checking the Battery

Check the battery terminals for corrosion monthly.

For jump starting, see page 111.

### ⚠ WARNING

The battery gives off explosive hydrogen gas during normal operation.

A spark or flame can cause the battery to explode with enough force to kill or seriously hurt you.

When conducting any battery maintenance, wear protective clothing and a face shield, or have a skilled technician do it.

**WARNING:** Battery posts, terminals, and related accessories contain lead and lead compounds. **Wash your hands after handling.**

## Window Washer Fluid

If the washer fluid level is low, fill the washer reservoir.

### Canadian models

If the washer fluid level is low, the washer level indicator or a message appears.



### NOTICE

Do not use engine antifreeze or a vinegar/water solution in the windshield washer reservoir. Antifreeze can damage your vehicle's paint. A vinegar/water solution can damage the windshield washer pump.

## Changing Wiper Blades

If the wiper blades leave streaks across the windshield, try cleaning them first with a paper towel or soft cloth and wiper fluid. If the wiper blade rubber has deteriorated, you should change the wiper blades.

### ■ Changing the Front Wiper Blade Rubber

1. Lift the driver side wiper arm first, then the passenger side.
2. Push the lock tab up.
3. Slide the blade from the wiper arm.
4. Slide the wiper blade out from its holder by pulling the tabbed end out.
5. Remove the retainers from the rubber blade that has been removed, and mount to a new rubber blade. Correctly align the rubber protrusion and the retainer grooves.
6. Slide the new wiper blade onto the holder from the bottom end. The tab on the holder should fit in the indent of the wiper blade.
7. Slide the wiper blade onto the wiper arm until it clicks.
8. Lower the passenger side wiper arm first, then the driver side.

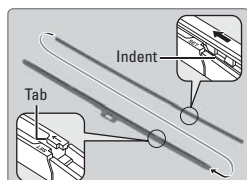
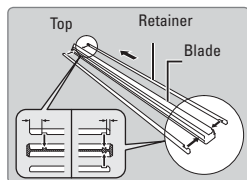
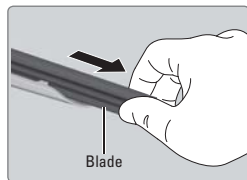
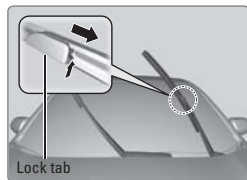
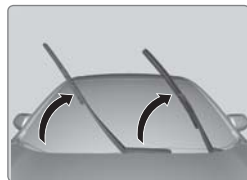

#### NOTICE

Avoid dropping the wiper arm, as it may damage the windshield.

### ■ Changing the Rear Wiper Blade Rubber

1. Lift the wiper arm off the window.
2. Pull up the lock tab and release the wiper arm.
3. Slide the wiper blade out from the end with the indent.
4. Remove the retainers from wiper blade and mount it to a new rubber blade.
5. Slide the new wiper blade onto the holder. Make sure it is engaged correctly, then install the wiper blade assembly onto the wiper arm.

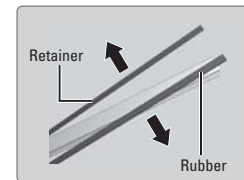
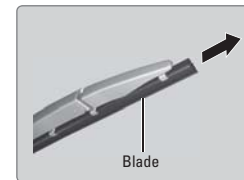
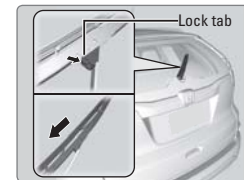

## Tire Information

To safely operate your vehicle, your tires must be of the proper type and size, in good condition with adequate tread, and properly inflated.

### Inflation Guidelines

- Properly inflated tires provide the best combination of handling, tread life, and comfort. Refer to the driver's doorjamb label or the specifications (see page 140) for the specified pressure.
- Underinflated tires wear unevenly, adversely affect handling and fuel economy, and are more likely to fail from overheating.
- Overinflated tires make your vehicle ride harshly, are more prone to road hazards, and wear unevenly.
- Every day before you drive, look at each of the tires. If one looks lower than the others, check the pressure with a tire gauge.
- Measure the air pressure when tires are cold. This means the vehicle has been parked for at least 3 hours, or driven less than 1 mile (1.6 km). If necessary, add or release air until the specified pressure is reached, and then calibrate the system (see page 115). If checked when hot, tire pressure can be as much as 4–6 psi (30–40 kPa, 0.3–0.5 kgf/cm<sup>2</sup>) higher than checked when cold.
- At least once a month or before long trips, use a gauge to measure the pressure in all tires, including the spare. Even tires in good condition can lose 1–2 psi (10–20 kPa, 0.1–0.2 kgf/cm<sup>2</sup>) per month.

### Inspection Guidelines

Every time you inflate the tires, check for the following:

- Any damage to tires, including bumps, bulges, cuts, splits, or cracks in the side or tread. Remove any foreign objects and inspect for air leaks. Replace tires if you see fabric or cord.
- Uneven or excessive tread wear. Have a dealer check the wheel alignment.
- Cracks or other damage around the valve stems.

### Wear Indicators

The groove where the wear indicator is located is 1/16 inch (1.6 mm) shallower than elsewhere on the tire. If the tread has worn so low that the indicator is exposed, replace the tire. **Worn out tires have poor traction on wet roads.**

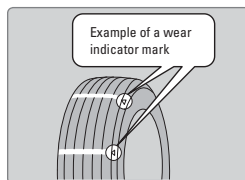

## WARNING

Using tires that are excessively worn or improperly inflated can cause a crash in which you can be seriously hurt or killed. Follow all instructions in this owner's manual regarding tire inflation and maintenance.

### Tire and Loading Information Label

The label attached to the driver's doorjamb provides necessary tire and loading information.

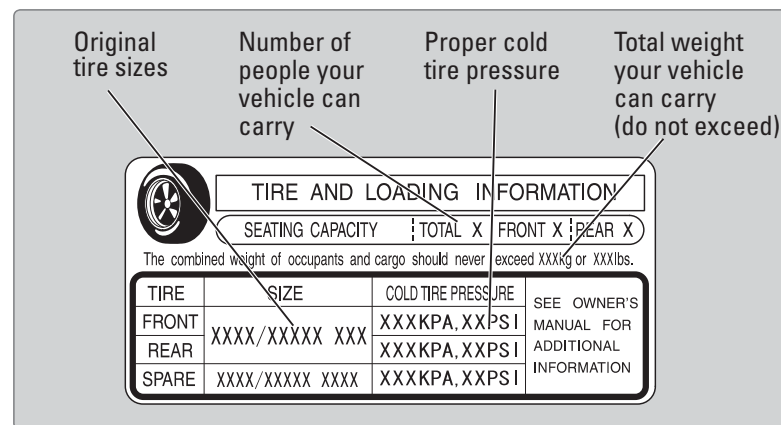

### Tire and Wheel Replacement

Replace your tires with radials of the same size, load range, speed rating, and maximum cold tire pressure rating (as shown on the tire's sidewall). Using tires of a different size or construction can cause certain vehicle systems to work incorrectly. It is best to replace all four tires at the same time. If that isn't possible, replace the front or rear tires in pairs.

If you change or replace a wheel, make sure that the wheel's specifications match those of the original wheels. Only use TPMS-specified wheels approved for your vehicle.

## WARNING

Installing improper tires on your vehicle can affect handling and stability. This can cause a crash in which you can be seriously hurt or killed. Always use the size and type of tires recommended in the Owner's Manual.

TABLE OF CONTENTS

VISUAL INDEX

SAFETY INFORMATION

INSTRUMENT PANEL

VEHICLE CONTROLS

AUDIO AND CONNECTIVITY

BLUETOOTH® HANDSFREELINK®

HONDALINK®

NAVIGATION

DRIVING

HANDLING THE UNEXPECTED

MAINTENANCE

SPECIFICATIONS

CUSTOMER INFORMATION

VOICE COMMAND INDEX

INDEX



**Tire Service Life**

The life of your tires is dependent on many factors, including driving habits, road conditions, vehicle loading, inflation pressure, maintenance history, speed, and environmental conditions (even when the tires are not in use).

In addition to regular inspections and inflation pressure maintenance, it is recommended that you have annual inspections performed once the tires reach five years old. All tires, including the spare, should be removed from service after 10 years from the date of manufacture, regardless of their condition or state of wear.

**Winter Tires**

If driving on snowy or frozen roads, mount all season tires marked "M+S", snow tires, or tire chains; reduce speed; and maintain sufficient distance between vehicles when driving. For winter tires, select the size and load ranges that are the same as the original tires, and mount them to all four wheels.

**Tire Chains**

Install tire chains on the front tires only. Because your vehicle has limited tire clearance, we strongly recommend using the following chains:

**Models with 215/70R16 tires:**

Cable type: SCC Radial Chain SC1042

**Models with 225/65R17 or P225/60R18 99H tires:**

Cable type: SCC Radial Chain TC2111MM

Mount chains as tightly as you can, and make sure that they do not touch the brake lines or suspension.

**NOTICE**

Traction devices that are the wrong size or improperly installed can damage your vehicle's brake lines, suspension, body, and wheels. Stop driving if they are hitting any part of the vehicle.

**WARNING**

Using the wrong chains, or not properly installing chains, can damage the brake lines and cause a crash in which you can be seriously injured or killed.

Follow all instructions in this guide regarding the selection and use of tire chains.

**Tire Labeling**

The tires that came on your vehicle have a number of markings. Those you should be aware of are described below.

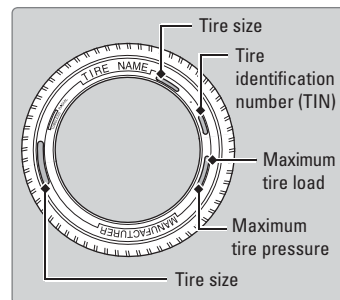

Here is an example of what each marking means:

**215/70R16 100S**

- 215: tire width in millimeters
- 70: aspect ratio (tire section height as a percentage of its width)
- R: tire construction code (radial)
- 16: rim diameter in inches
- 100: load index (code indicating maximum load tire can carry)
- S: speed symbol (code indicating maximum speed rating)

**Tire Identification Number (TIN)**

The tire identification number (TIN) is a group of numbers and letters that look like the example below. TIN is located on the sidewall of the tire.

DOT B97R FW6X 2209  
 DOT: This indicates that the tire meets all requirements of the U.S. Department of Transportation.  
 B97R: Manufacturer's identification mark  
 FW6X: Tire type code  
 22 09: Date of Transportation  
 Year  
 Week

**Glossary of Tire Terminology**

**Cold Tire Pressure** – The tire air pressure when the vehicle has been parked for at least three hours or driven less than 1 mile (1.6 km).

**Load Rating** – The maximum load that a tire is rated to carry for a given inflation pressure.

**Maximum Inflation Pressure** – The maximum tire air pressure that the tire can hold.

**Maximum Load Rating** – The load rating for a tire at the maximum permissible inflation pressure for that tire.

**Recommended Inflation Pressure** – The cold tire inflation pressure recommended by the manufacturer.

**Treadwear Indicators (TWI)** – The projections within the principal grooves designed to give a visual indication of the degrees of wear of the tread.

TABLE OF CONTENTS  
 VISUAL INDEX  
 SAFETY INFORMATION  
 INSTRUMENT PANEL  
 VEHICLE CONTROLS  
 AUDIO AND CONNECTIVITY  
 BLUETOOTH® HANDSFREELINK®  
 HONDALINK®

NAVIGATION  
 DRIVING  
 HANDLING THE UNEXPECTED  
 MAINTENANCE  
 SPECIFICATIONS  
 CUSTOMER INFORMATION  
 VOICE COMMAND INDEX  
 INDEX

## DOT Tire Quality Grading

The tires on your vehicle meet all U.S. Federal Safety Requirements. All tires are also graded for treadwear, traction, and temperature performance according to Department of Transportation (DOT) standards. The following explains these gradings.

### ■ Uniform Tire Quality Grading

Quality grades can be found where applicable on the tire sidewall between tread shoulder and maximum section width.

For example:

*Treadwear 200*

*Traction AA*

*Temperature A*

All passenger car tires must conform to Federal Safety Requirements in addition to these grades.

### ■ Treadwear

The treadwear grade is a comparative rating based on the wear rate of the tire when tested under controlled conditions on a specified government test course. For example, a tire graded 150 would wear one and one-half (1 1/2) times as well on the government course as a tire graded 100. The relative performance of tires depends upon the actual conditions of their use, however, and may depart significantly from the norm due to variations in driving habits, service practices, and differences in road characteristics and climate.

### ■ Traction

The traction grades, from highest to lowest, are AA, A, B, and C. Those grades represent the tire's ability to stop on wet pavement as measured under controlled conditions on specified government test surfaces of asphalt and concrete. A tire marked C may have poor traction performance.

**WARNING:** The traction grade assigned to this tire is based on straight-ahead braking traction tests, and does not include acceleration, cornering, hydroplaning, or peak traction characteristics.

### ■ Temperature

The temperature grades are A (the highest), B, and C, representing the tire's resistance to the generation of heat and its ability to dissipate heat when tested under controlled conditions on a specified indoor laboratory test wheel. Sustained high temperature can cause the material of the tire to degenerate and reduce tire life, and excessive temperature can lead to sudden tire failure. The grade C corresponds to a level of performance which all passenger car tires must meet under the Federal Motor Vehicle Safety Standard No. 109. Grades B and A represent higher levels of performance on the laboratory test wheel than the minimum required by law.

**WARNING:** The temperature grade for this tire is established for a tire that is properly inflated and not overloaded. Excessive speed, underinflation, or excessive loading, either separately or in combination, can cause heat buildup and possible tire failure.

## Tire Pressure Monitoring System (TPMS) - Required Federal Explanation

### U.S. models only

Each tire, including the spare (if provided), should be checked monthly when cold and inflated to the inflation pressure recommended by the vehicle manufacturer on the vehicle placard or tire inflation pressure label.

(If your vehicle has tires of a different size than the size indicated on the vehicle placard or tire inflation pressure label, you should determine the proper tire inflation pressure for those tires.)

As an added safety feature, your vehicle has been equipped with a tire pressure monitoring system (TPMS) that illuminates a low tire pressure telltale when one or more of your tires is significantly under-inflated.



Accordingly, when the low tire pressure telltale illuminates, you should stop and check your tires as soon as possible, and inflate them to the proper pressure.

Driving on a significantly under-inflated tire causes the tire to overheat and can lead to tire failure. Under-inflation also reduces fuel efficiency and tire tread life, and may affect the vehicle's handling and stopping ability.

Please note that the TPMS is not a substitute for proper tire maintenance, and it is the driver's responsibility to maintain correct tire pressure, even if under-inflation has not reached the level to trigger illumination of the TPMS low tire pressure telltale.

Your vehicle has also been equipped with a TPMS malfunction indicator to indicate when the system is not operating properly. The TPMS malfunction indicator is combined with the low tire pressure telltale. When the system detects a malfunction, the telltale will flash for approximately one minute and then remain continuously illuminated. This sequence will continue upon subsequent vehicle start-ups as long as the malfunction exists.

When the malfunction indicator is illuminated, the system may not be able to detect or signal low tire pressure as intended.

TPMS malfunctions may occur for a variety of reasons, including the installation of replacement or alternate tires or wheels on the vehicle that prevent the TPMS from functioning properly.

Always check the TPMS malfunction telltale after replacing one or more tires or wheels on your vehicle to ensure that the replacement or alternate tires and wheels allow the TPMS to continue to function properly.

## Testing of Readiness Codes

Your vehicle has "readiness codes" as part of the onboard self-diagnostic system. Some states refer to these codes as a test to see if your vehicle's emissions components are working properly. The codes may not be read if you go through the testing just after the battery has gone dead or been disconnected.

To check if they are set, turn the vehicle on without starting the engine. The malfunction indicator lamp will come on for several seconds. If it goes off, the readiness codes are set. If it blinks five times, the readiness codes are not set.

If you are required to have your vehicle tested before the readiness codes are set, prepare the vehicle for retesting by doing the following:

1. Fill the gas tank to approximately 3/4 full.
2. Park the vehicle and leave the engine off for 6 hours or more.
3. Make sure the ambient temperature is between 40°F and 95°F (4°C and 35°C).
4. Start the engine without touching the accelerator pedal, and let it idle for 20 seconds.
5. Keep the vehicle in Park (P). Increase the engine speed to 2,000 rpm, and hold it there for about 3 minutes.
6. Let the engine idle with your foot off the accelerator for 20 seconds.
7. Select a nearby, lightly traveled major highway where you can maintain a speed of 50 to 60 mph (80 to 97 km/h) for at least 20 minutes. Drive on the highway with the vehicle in Drive. Do not use cruise control. When traffic allows, drive for 90 seconds without using the accelerator pedal. (Vehicle speed may vary slightly; this is OK.) If you cannot do this for a continuous 90 seconds because of traffic conditions, drive for at least 30 seconds, then repeat two more times (for a total of 90 seconds).
8. Drive in city/suburban traffic for at least 10 minutes. When traffic conditions allow, let the vehicle coast for several seconds without using the accelerator pedal or the brake pedal.
9. Park the vehicle and leave the engine off for 30 minutes.

The readiness codes are erased when the battery is disconnected, and set again only after several days of driving under a variety of conditions.

If a testing facility determines that the readiness codes are not set, you may be requested to return at a later date to complete the test, or see your dealer.

TABLE OF CONTENTS  
VISUAL INDEX  
SAFETY INFORMATION  
INSTRUMENT PANEL  
VEHICLE CONTROLS  
AUDIO AND CONNECTIVITY  
BLUETOOTH® HANDSFREE LINK®  
HONDALINK®

NAVIGATION  
DRIVING  
HANDLING THE UNEXPECTED  
MAINTENANCE  
SPECIFICATIONS  
CUSTOMER INFORMATION  
VOICE COMMAND INDEX  
INDEX

# SPECIFICATIONS

## Vehicle

Model	Honda CR-V	
No. of Passengers:		
Front	2	
Rear	3	
Total	5	
<b>Weights:</b>		
Gross Vehicle Weight Rating	U.S.:	4,464 lbs (2,025 kg) <sup>*1</sup> 4,519 lbs (2,050 kg) <sup>*2, *3</sup> 4,564 lbs (2,070 kg) <sup>*4</sup> 4,630 lbs (2,100 kg) <sup>*5</sup>
	Canada:	2,025 kg <sup>*6</sup> 2,050 kg <sup>*7</sup> 2,070 kg <sup>*8</sup> 2,100 kg <sup>*9</sup>
Gross Axle Weight Rating (Front)	U.S.:	2,271 lbs (1,030 kg) <sup>*1</sup> 2,326 lbs (1,055 kg) <sup>*2, *3, *4</sup> 2,348 lbs (1,065 kg) <sup>*5</sup>
	Canada:	1,030 kg <sup>*6</sup> 1,055 kg <sup>*7, *8</sup> 1,065 kg <sup>*9</sup>
Gross Axle Weight Rating (Rear)	U.S.:	2,238 lbs (1,015 kg) <sup>*1, *2, *3</sup> 2,282 lbs (1,035 kg) <sup>*4</sup> 2,326 lbs (1,055 kg) <sup>*5</sup>
	Canada:	1,015 kg <sup>*6, *7</sup> 1,035 kg <sup>*8</sup> 1,055 kg <sup>*9</sup>

- \*1: LX and EX models with 2WD  
 \*2: EXL and TOURING models with 2WD  
 \*3: LX models with AWD  
 \*4: EX models with AWD  
 \*5: EXL and TOURING models with AWD  
 \*6: LX models with 2WD  
 \*7: LX models with AWD  
 \*8: EX and SE models with 4WD  
 \*9: EXL and TOURING models with AWD

Air Conditioning:	
Refrigerant Type	HFC-134a (R-134a)
Charge Quantity	13.6 – 15.4 oz (385 – 435 g)
Lubricant Type	SP-10

## Engine and Fuel

Engine Specifications	
Displacement	144 cu-in (2,356 cm <sup>3</sup> )
Spark Plugs	NGK DILKAR7H11GS DILKAR7G11GS DENSO DXE22HQ-R-D11S
Fuel	
Fuel Type	Unleaded gasoline, Pump octane number of 87 or higher
Fuel Tank Capacity	15.3 US gal (58 l)

## Tires

Regular	Size	215/70R16 100S <sup>*1</sup> 225/65R17 102T <sup>*2</sup> P225/60R18 99H <sup>*3</sup>
	Pressure psi (kPa [kgf/cm <sup>2</sup> ])	32 (220 [2.2]) <sup>*1</sup> 33 (230 [2.3]) <sup>*2</sup> 30 (210 [2.1]) <sup>*3</sup>
	Compact Spare	T165/80D17 104M
Wheel Size	Regular	16 x 6.5J <sup>*1</sup> 17 x 7J <sup>*2</sup> 18 x 7J <sup>*3</sup>
	Compact Spare	17 x 4T

- \*1: Vehicle with 16 inch wheel  
 \*2: Vehicle with 17 inch wheel  
 \*3: Vehicle with 18 inch wheel

## Light Bulbs

Headlights (Low Beam)	55W (H11)
Headlights (High Beam)	60W (H83)
Fog Lights*	35W (H8)
Front Turn Signal/Side Marker/ Parking Lights	28/8W (Amber)
Front Turn Signal/ Side Marker Lights*	28/8W (Amber)
Side Turn Signal Lights (on Door Mirrors)*	LED
Parking Lights*	LED
Upper Rear Side Marker/Tailights	3CP
Lower Rear Side Marker/Brake/ Tailights	21/5W
Back-Up Lights	21W
Rear Turn Signal Lights	21W (Amber)
High-Mount Brake Light	LED
Rear License Plate Light	3CP
Cargo Area Light	8W
Vanity Mirror Lights*	1.4W
<b>Interior Lights</b>	
Map Lights	8W
Ceiling Light	8W

## Fluids

Specified	Honda Heavy Duty Brake Fluid DOT 3
-----------	------------------------------------

Continuously Variable Transmission Fluid	
Specified	Honda HCF-2 Transmission Fluid
Capacity	Change 3.9 US qt (3.7 l) <sup>*1</sup> 4.5 US qt (4.3 l) <sup>*2</sup>

- \*1: 2WD models  
 \*2: AWD models

Engine Coolant	
Specified	Honda Long-Life Antifreeze/Coolant Type2
Ratio	50/50 with distilled water
Capacity	1.66 US gal (6.3 l) (change including the remaining 0.16 US gal (0.62 l) in the reserve tank)

Engine Oil	
Recommended	Honda Genuine Motor Oil 0W-20 API Premium-grade 0W-20 detergent oil
Capacity	Change 4.4 US qt (4.2 l) Change including filter 4.6 US qt (4.4 l)

Rear Differential Fluid*	
Specified	Honda Dual Pump Fluid II
Capacity	Change 1.32 US qt (1.247 l) Total 1.57 US qt (1.488 l)

Washer Fluid	
Tank Capacity	U.S.: 2.6 US qt (2.5 l) Canada: 4.8 US qt (4.5 l)

# CUSTOMER INFORMATION

Learn about information specific to you as a Honda customer and how to get help.

## Frequently Asked Questions/Troubleshooting

Below are some frequently asked questions and troubleshooting items that you may have about the vehicle.

**Q:** *How do I set the vehicle clock?*

**A:** For vehicles without navigation, see page 53. For vehicles with navigation, the time is automatically set using GPS signals.

**Q:** *Why doesn't the vehicle start when I press the ENGINE START/STOP button?\**

**A:** The brake pedal must be pressed to start the engine.

**Q:** *What is the AUTO setting on my headlight lever?*

**A:** When in the AUTO position, the vehicle's exterior lights will automatically turn on or off depending on the ambient lighting.

**Q:** *Why won't the driver's door unlock when I grab the door handle, even though the keyless access remote is within range?\**

**A:** If you pull the handle too quickly, the system may not have time to confirm the door is unlocked. Wait to hear a beep to confirm the door is unlocked. If you are wearing gloves, the system may be slow to respond.

**Q:** *After my battery was disconnected or went dead, the audio system is asking for a code. Where do I find this?*

**A:** In most cases, you do not need to enter a code. Turn on the vehicle and the audio system, and press and hold the power button until the system reactivates.

**Q:** *Why can't I operate Pandora® through the audio system?*

**A:** Audio may be streaming through Bluetooth® Audio. Make sure Pandora mode is selected and the phone cable is properly connected to the USB adapter. Some phones may prompt you to "Allow" a connection.

**Q:** *Is my phone compatible with Bluetooth features?*

**A:** Visit [handsfreelink.com](http://handsfreelink.com) (U.S.) or [handsfreelink.ca](http://handsfreelink.ca) (Canada) to check phone compatibility for Bluetooth® Audio, Bluetooth® HandsFreeLink®, and SMS text messaging.

**Q:** *Every time I press the Talk button, the system gives me voice prompts. Can I turn these off?\**

**A:** From the Home screen, select Settings. Select the Voice Recog tab, then select Voice Prompt. Select Off.

\*if equipped

**Q:** Why can't I select an item using the selector knob or touchscreen\*?

**A:** To prevent driver distraction, certain items are limited or inoperable while the vehicle is moving. Use voice commands or pull over to select the items.

**Q:** Where can I find the vehicle identification number (VIN)?

**A:** Check the label on the driver's doorjamb.

## Contact Us

Honda dealer personnel are trained professionals. They should be able to answer all your questions. If you encounter a problem that your dealership does not solve to your satisfaction, please discuss it with the dealership's service manager or general manager. If you are dissatisfied with the decision made by the dealership's management, contact Honda Automobile Customer Service.

### U.S. Owners:

American Honda Motor Co., Inc.  
Honda Automobile Customer Service  
1919 Torrance Blvd.  
Mail Stop 500-2N-7A  
Torrance, CA 90501-2746  
Tel: (800) 999-1009

### In Puerto Rico and the U.S. Virgin Islands:

Bella International  
P.O. Box 190816  
San Juan, PR 00919-0816  
Tel: (787) 620-7546

### Canadian Owners:

Honda Canada, Inc.  
Customer Relations  
180 Honda Blvd.  
Markham, ON  
L6C 0H9  
Tel: (888) 946-6329  
Fax: (877) 939-0909  
e-mail: honda\_cr@ch.honda.com

When you call or write, please give us the following information:

- Vehicle Identification Number
- Date of purchase
- Odometer reading of your vehicle
- Your name, address, and telephone number
- A detailed description of the problem
- Name of the dealer who sold the vehicle to you

\*if equipped

## Honda Roadside Assistance

24-hour emergency road service is available to you in the United States and Canada throughout your 3-year/36,000-mile warranty term. Services include jump starting, flat tire and lockout assistance, towing, and more (limitations apply).

Call (866) 864-5211 (U.S.) or (800) 465-7587 (Canada).

## Warranty Coverages

Below is a brief summary of the warranties covering your new vehicle.

**New Vehicle Limited Warranty:** Covers your new vehicle, except for the emissions control system and accessories, against defects in materials and workmanship.

**Emissions Control Systems Defects Warranty and Emissions Performance Warranty:** Covers your vehicle's emissions control systems. Time, mileage, and coverage are conditional.

**Seat Belt Limited Warranty:** Covers seat belts that fail to function properly.

**Rust Perforation Limited Warranty:** Covers all exterior body panels that rust through from the inside.

**Accessory Limited Warranty:** Covers Honda accessories.

**Replacement Parts Limited Warranty:** Covers all Honda replacement parts against defects in materials and workmanship.

**Replacement Battery Limited Warranty:** Provides prorated coverage for a replacement battery purchased from a Honda dealer.

**Replacement Muffler Lifetime Limited Warranty:** Covers a replacement muffler for the duration of the ownership.

Restrictions and exclusions apply to all these warranties. See the Warranty Manual on the Owner Information CD or at [owners.honda.com](http://owners.honda.com) (U.S.) or [myhonda.ca](http://myhonda.ca) (Canada) for complete descriptions of each warranty, including time, mileage, and other conditional limitations.

Your vehicle's original tires are covered by their manufacturer. Tire warranty information can be found on the Owner Information CD or at [owners.honda.com](http://owners.honda.com) (U.S.) or [myhonda.ca](http://myhonda.ca) (Canada).

# VOICE COMMAND INDEX

Learn about all available voice commands to help you operate the vehicle. Available on vehicles with navigation.

Press the Talk button before you say a command. To view a list of available commands in the vehicle, say “Voice help.” Select a category to hear the commands read aloud.

## Global Commands

The system accepts these commands on any screen.

- Voice help
- Display menu
- Display setting
- Display navigation
- Display information
- Display audio
- Display phone
- Back/Cancel
- What is today's date?
- What time is it?

## Navigation Commands

The system accepts these commands on the map/guidance screen.

### General Commands

- Display map
- Display navigation
- Go home 1 (or 2)

### Map Display Commands

- Display current location
- Display/Hide (specify icon type):
  - ATM
  - gas station
  - restaurant
  - post office
  - grocery store
  - lodging (hotel, motel)
  - parking garage
  - parking lot
  - school
  - hospital
  - freeway exit information
  - traffic
  - traffic speeds
  - traffic icons
  - traffic incidents
- Display north up
- Display heading up
- Display 3D map
- Display zoom in
- Display zoom out

## Navigation Commands (continued)

### Find Place Commands

- Find nearest (specify place):
  - Fuel and auto
  - Honda dealers
  - Gas station
  - Auto parts & electronics
  - Auto repair & maintenance
  - Car wash & detailing
  - Motorcycle dealers
  - Other car dealerships
  - Roadside assistance
  - ATM
  - Bank
  - Check cashing
  - Currency exchange
  - Community
  - Business
  - City hall
  - Civic center
  - Convention center
  - Court house
  - Higher education
  - Library
  - Post office
  - School
  - Emergency room
  - Hospital
  - Police station
  - Veterinarian
  - Lodging
  - Bed & breakfast
  - Hotel
  - Resort
  - Recreation
  - Amusement park
  - Golf course
  - Historical monument
  - Marina
  - Movie theater
  - Museum
  - Park
  - Performing arts
  - Sports complex
  - Tourist attraction
  - Restaurant
  - American restaurant
  - Californian restaurant
  - Chinese restaurant
  - Coffee shop
  - Continental restaurant
  - Fast food
  - French restaurant
  - German restaurant
  - Greek restaurant
  - Indian restaurant
  - Italian restaurant
  - Japanese restaurant
  - Korean restaurant
  - Mexican restaurant
  - Pizza
  - Seafood restaurant
  - Thai restaurant
  - Vegetarian restaurant
  - Vietnamese restaurant
  - Other restaurant
  - Shopping
  - Shopping area
  - Accessory store
  - Book store
  - Clothing store
  - Grocery store
  - Home improvement store
  - Mall
  - Office supply store
  - Pharmacy
  - Pet food store
  - Sewing store
  - Shoe store
  - Sporting goods store
  - Toy store



- Travel center
- Airport
- Automobile club
- Bus station
- Camping
- Commuter rail station
- Ferry terminal
- Named place
- Park & ride
- Parking garage
- Parking lot
- Rental car agency
- Rest area
- Ski area
- Tourist information
- Train station
- Travel agency
- Truck stop

### Route Commands

The system accepts these commands when a route is set.

- How long to the destination?
- How far to the destination?
- Display destination map
- Display entire route
- Cancel route
- Repeat guidance
- Route menu

### Climate Control Commands

The system accepts these commands on most screens.

- Climate control automatic (maintains selected temperature)
- Climate control on\*
- Climate control off\*
- Air conditioner on\*
- Air conditioner off\*
- Climate control defrost on\*
- Climate control defrost off\*
- Rear defrost on\*
- Rear defrost off\*
- Climate control fresh air
- Climate control recirculate
- Climate control sync on\*
- Climate control sync off\*
- Climate control vent
- Climate control bi-level (vent and floor)
- Climate control floor
- Climate control floor and defrost
- Climate control mode automatic
- Fan speed up
- Fan speed down
- Fan speed # (#: 1 to 7)
- Fan automatic
- Rear lock on
- Rear lock off
- Temperature # degrees (#: 57 to 87°F)
- Driver temperature # degrees (#: 57 to 87°F)
- Passenger temperature # degrees (#: 57 to 87°F)
- Temperature up
- Temperature down
- Driver temperature up
- Driver temperature down
- Passenger temperature up
- Passenger temperature down
- Temperature max heat
- Temperature max cool
- Driver temperature max heat
- Driver temperature max cool
- Passenger temperature max heat
- Passenger temperature max cool
- Front climate control automatic
- Front climate control off
- Rear climate control automatic
- Rear climate control off
- Rear climate control vent
- Rear climate control bi-level
- Rear climate control floor
- Rear fan speed up
- Rear fan speed down
- Rear fan speed # (#:1 to 5)
- Rear temperature up
- Rear temperature down
- Rear temperature max heat
- Rear temperature max cool

\* These commands toggle the function on and off, so the command may not match your intended action.

## ■ Audio Commands

The system accepts these commands on most screens. Audio volume levels cannot be controlled using voice commands.

### FM/AM Radio Commands

- Audio on\*
- Audio off\*
- Radio on\*
- Radio off\*
- Radio select FM
- Radio select AM
- Radio tune to # FM (#: frequency, e.g., 95.5)
- Radio tune to # AM (#: frequency, e.g., 1020)
- Radio seek up
- Radio seek down
- Radio next station
- Radio preset # (#: 1 to 12)
- Radio FM preset # (#: 1 to 12)
- Radio AM preset # (#: 1 to 6)
- Radio scan\*

### SiriusXM® Radio Commands

- Radio select XM
- XM channel # (#: 0 to 255)
- XM channel up
- XM channel down
- XM category up
- XM category down
- XM preset # (#: 1 to 12)
- XM scan\*
- XM category mode
- XM channel mode

### Disc Commands

- Disc play
- Disc play track # (#: 1 to 30)
- Disc skip forward
- Disc skip back
- Disc track random\*
- Disc track repeat\*
- Disc track scan\*
- Disc folder up
- Disc folder down
- Disc folder repeat\*
- Disc folder scan\*
- Disc normal play

## ■ Audio Commands (continued)

### USB Commands

- USB play
- USB play track # (#: 1 to 30)
- USB skip forward
- USB skip back
- USB track random\*
- USB track repeat\*
- USB track scan\*
- USB folder up
- USB folder down
- USB folder random\*
- USB folder repeat\*
- USB folder scan\*
- USB normal play

### iPod® Commands

- Music search
- iPod play
- iPod play track # (#: 1-30)
- iPod skip forward
- iPod skip back
- iPod track shuffle\*
- iPod album shuffle\*
- iPod track repeat\*
- iPod normal play
- What/Who am I listening to?
- Who is this?
- What's playing?
- Who's playing?
- What album is this?

### Pandora® Commands

- Pandora play\*
- Pandora skip forward
- Pandora station up
- Pandora station down
- Pandora pause\*
- Pandora resume\*
- Pandora like this song
- Pandora dislike this song

### Bluetooth® Audio Commands

- Bluetooth audio play
- Bluetooth audio skip forward
- Bluetooth audio skip back
- Bluetooth audio pause
- Bluetooth audio resume
- Bluetooth audio group up
- Bluetooth audio group down

Commands may not work on some phones or devices.

### AUX Commands

- Auxiliary play

\*These commands toggle the function on and off, so the command may not match your intended action.

\*These commands toggle the function on and off, so the command may not match your intended action.

**Phone Commands**

The system accepts these commands on most screens.

- Dial/call by number
- Dial/call by voice tag

**Info Commands**

The system accepts these commands on most screens.

- Trip computer
- Display clock
- Display traffic list
- Display wallpaper
- Display traffic on my route

**On-screen Commands**

The system accepts these commands on any screen where applicable. All available commands are highlighted in yellow when you press the Talk button.

- Next (or Down)
- Previous (or Up)
- Return
- OK (excluding Startup Confirmation screen)
- Delete

**INDEX**

ABS .....	25, 99	SMS Text Messaging .....	77, 83
Adaptive Cruise Control (ACC).....	25, 102	Speed Dial .....	76, 82
Airbags .....	9	Voice Recognition Tips.....	79
Advanced Airbags .....	9	Brake Assist System.....	99
Airbag Care .....	14	Brake system .....	24, 25
Airbag System Components.....	13	Braking .....	99
Airbag System Indicators .....	11	Brightness Control.....	39
Front Airbags (SRS) .....	9	Built-in key .....	32
Passenger Airbag Off Indicator.....	12	Calibration .....	115
Side Airbags.....	10	Carbon Monoxide Gas.....	4
Side Curtain Airbags.....	10	Cargo Area Lights .....	39
Supplemental Restraint System Indicator...	11	Changing a Flat Tire .....	116
Air Conditioning System.....	50	Changing Settings.....	30, 31
All Wheel Drive (AWD).....	25	Changing Wiper Blades .....	130
Ambient Meter.....	100	Charging system.....	24
Anti-lock Brake System (ABS).....	25, 99	Child Safety .....	15
Audio Operation .....	54	Childproof Door Locks.....	34
Accessory Power Socket .....	54	Selecting a Child Seat.....	17
Audio Commands .....	148	Child Seat .....	17
Auxiliary Input Jack.....	55	Adding Security with a Tether .....	20
Bluetooth® Audio .....	62, 71	LATCH-Compatible Child Seat.....	18
Compact Disc (CD).....	59, 68	Climate Control Commands .....	147
FM/AM Radio.....	58, 66	Climate Control System.....	51
HDMI Port.....	55	Clock .....	53
HDMI Video.....	73	Collision Mitigation Braking System™ (CMBS™).....	25, 27, 106
HondaLink™.....	65	Compact Disc (CD).....	59, 68
Intelligent Multi-Information Display (i-MID).....	57	Compact Disc (CD) Commands.....	148
iPod® .....	60, 69	Contact Us.....	142
Pandora® .....	63, 72	Cruise Control .....	27, 101
SiriusXM® Radio .....	67	Customer Information.....	141
Sound .....	56	Customized Features .....	31
Steering Wheel Controls.....	55	Dashboard and Ceiling Controls.....	2
Touchscreen Operation .....	64	Daytime Running Lights (DRL).....	25
USB Adapter Cable.....	54	Destination .....	88
USB Flash Drive.....	61, 70	Detour .....	91
USB Port .....	54	Dialing a Number .....	76, 81
Automatic Dimming Rearview Mirror.....	48	Door Mirrors .....	48
Automatic Headlights.....	40	Door Operation .....	34
Automatic Wipers .....	41	Door/tailgate open.....	26
AUX Commands.....	149	DOT Tire Quality Grading .....	136
Auxiliary Input Jack.....	55	Driver's power seat.....	42
AWD .....	25	Driving .....	92
Battery .....	129	Braking.....	99
Bluetooth® Audio .....	62, 71	Cruise Control.....	101
Bluetooth® Audio Commands .....	149	Ignition.....	97
Bluetooth® HandsFreeLink® (HFL).....	74	Lane Departure Warning (LDW) ...	25, 27, 104
E-Mail.....	83	Lane Keeping Assist System (LKAS)...	25, 27, 105
HFL Controls.....	74, 78	LaneWatch™ .....	107
HondaLink™ Assist.....	84	Maximum Load Limit.....	94
Making a Call .....	76, 81	Multi-View Rear Camera .....	108, 109
Pairing a Phone .....	75, 80	Power Mode .....	97
Siri Eyes Free .....	84	Refueling.....	110

Shifting.....98  
 Towing a Trailer.....96  
 Driving Position Memory System.....47  
 Eco Assist System.....100  
 ECON Button.....100  
 ECON mode.....27  
 Electric Power Steering (EPS).....25  
 Electronic Stability Control (ESC).....100  
 E-Mail.....83  
 Emergency Engine Stop.....114  
 Emergency Towing.....114  
 Engine and Fuel Specs.....140  
 Engine Coolant.....128  
 Engine Oil.....126  
 ENGINE START/STOP button.....97  
 Exterior Lights.....27, 40  
 Fastening a Seat Belt.....7  
 Find Nearest Place.....89  
 Find Place Commands.....145  
 Flat Tire.....116  
 Floor Mats.....45  
 Fluids.....140  
 FM/AM Radio.....58, 66  
 FM/AM Radio Commands.....148  
 Fog lights.....27, 40  
 Foot Brake.....99  
 Frequently Asked Questions.....141  
 Front Airbags (SRS).....9  
 Front Door Inner Handle.....34  
 Front Seats.....42  
 Front Wipers.....41  
 Fuel Information.....110  
 Fuse Locations.....119  
 Garage Opener.....49  
 Handling Information.....4  
 Hazard lights.....27  
 HDMI Port.....55  
 HDMI Video.....73  
 Head Restraints.....44  
 Headlight-Wiper Integration.....41  
 Heated Windshield Button.....51  
 HFL Controls.....74, 78  
 High beams.....27  
 Home Address.....88  
 HomeLink® Garage Opener.....49  
 Honda Roadside Assistance.....143  
 HondaLink™.....65  
 HondaLink™ Assist.....84  
 Hood.....125  
 Ignition.....97  
 i-MID.....57  
 Immobilizer.....27  
 Info buttons.....29, 30  
 Info Commands.....150  
 Information Display.....28  
 Instrument Panel.....24  
 Condition Indicators.....26  
 Malfunction Indicators.....24  
 On/Off Indicators.....27  
 Intelligent Multi-Information Display (i-MID).....57  
 Interior Lights.....39  
 Intermittent Wipers.....41  
 iPod®.....60, 69  
 iPod® Commands.....149  
 Jump Starting.....111  
 Key.....32  
 Lane Departure Warning (LDW).....25, 27, 104  
 Lane Keeping Assist System (LKAS).....25, 27, 105  
 LaneWatch™.....107  
 Lap/Shoulder Seat Belts.....5  
 LATCH-Compatible Child Seat.....18  
 LDW.....25, 27, 104  
 Lights.....27, 39  
 LKAS.....25, 27, 105  
 Lock Tab.....34  
 Low fuel.....26  
 Low oil pressure.....24  
 Low tire pressure.....26  
 Maintenance.....122  
 Maintenance Minder™.....27, 123  
 Safety Precautions.....122  
 Service Codes.....124  
 Under the Hood.....125  
 Making a Call.....76, 81  
 Malfunction indicator lamp.....25  
 Manual seats.....43  
 Map Display Commands.....144  
 Map Legend.....90  
 Map Lights.....39  
 Master Door Lock Switch.....34  
 Maximum Load Limit.....94  
 Mirrors.....48  
 Moonroof.....38  
 Multi-Information Display.....29  
 Multi-View Rear Camera.....108, 109  
 Navigation.....85  
 Detour.....91  
 Display and Controls.....86  
 Entering a Destination.....88  
 Find Nearest Place.....89  
 Home Address.....88  
 Map Legend.....90  
 Navigation Commands.....144  
 Place Category.....89  
 Routing.....90  
 Steering Wheel Controls.....85  
 Street Address.....88  
 Traffic.....91

Turn-by-Turn Directions.....90  
 Voice Prompt.....87  
 Voice Recognition Tips.....87  
 One-Touch Turn Signal.....40  
 On-screen Commands.....150  
 Opening the Hood.....125  
 Overheating.....113  
 Pairing a Phone.....75, 80  
 Pandora®.....63, 72  
 Pandora® Commands.....149  
 Panic button.....32  
 Parking brake.....26, 99  
 Passenger Airbag Off Indicator.....12  
 Phone.....75, 80  
 Phonebook.....76, 81  
 Phone Commands.....150  
 Place Category.....89  
 Power Door Mirrors.....48  
 Power Mode.....97  
 Power Moonroof.....38  
 Power seat.....42  
 Power Tailgate.....36  
 Power Windows.....37  
 Radio.....58, 66  
 Readiness Codes.....139  
 Rear Camera.....108, 109  
 Rear Seats.....46  
 Rearview Mirror.....48  
 Rear Wiper.....41  
 Refueling.....110  
 Remote Battery Strength.....111  
 Remote Transmitter.....32  
 Reporting Safety Defects.....23  
 Roadside Assistance.....143  
 Route Commands.....146  
 Routing.....90  
 Safety Information.....3  
 Carbon Monoxide Gas.....4  
 Childproof Door Locks.....34  
 Child Safety.....15  
 Handling Information.....4  
 Reporting Safety Defects.....23  
 Safety Label Locations.....22  
 Safety Messages.....3  
 Seat Belts.....5  
 Fastening a Seat Belt.....7  
 Lap/Shoulder Seat Belts.....5  
 Seat Belt Inspection.....6  
 Seat belt reminder.....26  
 Seat Belt with Detachable Anchor.....8  
 Shoulder Anchor.....7  
 Seat Heaters.....52  
 Seats.....42  
 Front Seats.....42  
 Rear Seats.....46  
 Select/reset knob.....28  
 SEL/RESET button.....29, 30  
 Service Codes.....124  
 Settings.....30, 31  
 Setting the Clock.....53  
 Shifting.....98  
 Shift Lever Does Not Move.....112  
 Shoulder Anchor.....7  
 Side Airbags.....10  
 Side Curtain Airbags.....10  
 Siri™ Eyes Free.....84  
 SiriusXM® Radio.....67  
 SiriusXM® Radio Commands.....148  
 Smart Entry system.....25, 33  
 SMS Text Messaging.....77, 83  
 Sound.....56  
 Specifications.....140  
 Speed Dial.....76, 82  
 Starter system.....25  
 Steering Wheel.....47  
 Steering Wheel and Nearby Controls.....1  
 Steering Wheel Controls.....55, 85  
 Street Address.....88  
 Supplemental Restraint System (SRS).....24  
 System message.....26  
 Tailgate.....33, 35  
 Tailgate open.....26  
 Text Messaging.....77, 83  
 Tire Chains.....134  
 Tire Information.....132  
 DOT Tire Quality Grading.....136  
 Inflation Guidelines.....132  
 Tire and Loading Information Label.....133  
 Tire and Wheel Replacement.....133  
 Tire Identification Number (TIN).....135  
 Tire Labeling.....135  
 Tire Service Life.....134  
 Tire Terminology.....135  
 Wear Indicators.....132  
 Tire Pressure Monitoring System (TPMS).....25, 115, 138  
 Tire Specs.....140  
 Tongue load.....96  
 Total trailer weight.....96  
 Touchscreen Operation.....64  
 Towing.....96, 114  
 Towing Load Limits.....96  
 TPMS.....25, 115, 138  
 Traffic.....91  
 Troubleshooting.....141  
 Turn-by-Turn Directions.....90  
 Turn Signal.....27, 40  
 Under the Hood.....125  
 USB Adapter Cable.....54  
 USB Commands.....149

TABLE OF CONTENTS

VISUAL INDEX

SAFETY INFORMATION

INSTRUMENT PANEL

VEHICLE CONTROLS

AUDIO AND CONNECTIVITY

BLUETOOTH® HANDSFREELINK®

HONDALINK®

NAVIGATION

DRIVING

HANDLING THE UNEXPECTED

MAINTENANCE

SPECIFICATIONS

CUSTOMER INFORMATION

VOICE COMMAND INDEX

INDEX

INDEX

USB Flash Drive.....61, 70  
 USB Port.....54  
 Vehicle Specs.....140  
 Vehicle Controls.....32  
 Vehicle Stability Assist (VSA®) ...25, 26, 27, 100  
 Visual Index.....1  
 Voice Command Index .....144  
 Voice Prompt .....87  
 Voice Recognition Tips.....79, 87  
 VSA .....25, 26, 27, 100  
 Warranty Coverages .....143  
 Wear Indicators .....132  
 Windows.....37  
 Window Washer Fluid .....129  
 Winter Tires.....134  
 Wiper Blades .....130  
 Wiper Operation.....41

INDEX