

2006 Element Online Reference Owner's Manual

Use these links (and links throughout this manual) to navigate through this reference.
For a printed owner's manual, click on authorized manuals or go to www.helminc.com.

Contents

Owner's Identification Form

Introduction	i
A Few Words About Safety	ii
Important Handling Information	iii
Your Vehicle at a Glance	4
Driver and Passenger Safety	7
Proper use and care of your vehicle's seat belts, and Supplemental Restraint System.	
Instruments and Controls	51
Instrument panel indicator and gauge, and how to use dashboard and steering column controls.	
Comfort and Convenience Features	89
How to operate the climate control system, the audio system, and other convenience features.	
Before Driving	123
What gasoline to use, how to break-in your new vehicle, and how to load luggage and other cargo.	
Driving	137
The proper way to start the engine, shift the transmission, and park, plus towing a trailer.	
Maintenance	161
The Maintenance Schedule shows you when you need to take your vehicle to the dealer.	
Taking Care of the Unexpected	195
This section covers several problems motorists sometimes experience, and how to handle them.	
Technical Information	219
ID numbers, dimensions, capacities, and technical information.	
Warranty and Customer Relations (U.S. and Canada)	233
A summary of the warranties covering your new Acura, and how to contact us.	
Authorized Manuals (U.S. only)	237
How to order manuals and other technical literature.	
Index	I

Service Information Summary

A summary of information you need when you pull up to the fuel pump.

Owner's Identification

OWNER _____

ADDRESS _____

STREET

CITY

STATE/PROVINCE

ZIP CODE/
POSTAL CODE

V. I. N. _____

DELIVERY DATE _____

(Date sold to original retail purchaser)

DEALER NAME _____ DEALER NO. _____

ADDRESS _____

STREET

CITY

STATE/PROVINCE

ZIP CODE/
POSTAL CODE

OWNER'S SIGNATURE _____

DEALER'S SIGNATURE _____

This owner's manual should be considered a permanent part of the vehicle and should remain with the vehicle when it is sold.

This owner's manual covers all models of the Element. You may find descriptions of equipment and features that are not on your particular model.

The information and specifications included in this publication were in effect at the time of approval for printing. Honda Motor Co., Ltd. reserves the right, however, to discontinue or change specifications or design at any time without notice and without incurring any obligation whatsoever.

Congratulations! Your selection of a 2006 Honda Element was a wise investment. It will give you years of driving pleasure.

One of the best ways to enhance the enjoyment of your new vehicle is to read this manual. In it, you will learn how to operate its driving controls and convenience items. Afterwards, keep this owner's manual in your vehicle so you can refer to it at any time.

Several warranties protect your new vehicle. Read the warranty booklet thoroughly so you understand the coverages and are aware of your rights and responsibilities.

Maintaining your vehicle according to the schedules given in this manual helps to keep your driving trouble-free while it preserves your investment. When your vehicle needs maintenance, keep in mind that your dealer's staff is specially trained in servicing the many systems unique to your vehicle. Your dealer is dedicated to your satisfaction and will be pleased to answer any questions and concerns.

As you read this manual, you will find information that is preceded by a **NOTICE** symbol. This information is intended to help you avoid damage to your vehicle, other property, or the environment.

California Proposition 65 Warning

WARNING: This product contains or emits chemicals known to the state of California to cause cancer and birth defects or other reproductive harm.

Event Data Recorders

This vehicle is equipped with one or more recording devices commonly referred to as event data recorders or sensing and diagnostic modules.

A Few Words About Safety

Your safety, and the safety of others, is very important. And operating this vehicle safely is an important responsibility.

To help you make informed decisions about safety, we have provided operating procedures and other information on labels and in this manual. This information alerts you to potential hazards that could hurt you or others.

Of course, it is not practical or possible to warn you about all the hazards associated with operating or maintaining your vehicle. You must use your own good judgement.

You will find this important safety information in a variety of forms, including:

- **Safety Labels** — on the vehicle.
- **Safety Messages** — preceded by a safety alert symbol  and one of three signal words: **DANGER**, **WARNING**, or **CAUTION**. These signal words mean:

 **DANGER**

You **WILL** be **KILLED** or **SERIOUSLY HURT** if you don't follow instructions.

 **WARNING**

You **CAN** be **KILLED** or **SERIOUSLY HURT** if you don't follow instructions.

 **CAUTION**

You **CAN** be **HURT** if you don't follow instructions.

- **Safety Headings** — such as Important Safety Reminders or Important Safety Precautions.
- **Safety Section** — such as Driver and Passenger Safety.
- **Instructions** — how to use this vehicle correctly and safely.

This entire book is filled with important safety information — please read it carefully.

Important Handling Information

Your Element has higher ground clearance than a passenger vehicle designed for use only on pavement. Higher ground clearance has many advantages for off-highway driving. It allows you to travel over bumps, obstacles, and rough terrain. It also provides good visibility so you can anticipate problems earlier.

These advantages come at some cost. Because your vehicle is taller and rides higher off the ground, it has a high center of gravity. This means your vehicle can tip or roll over if you make abrupt turns. Utility vehicles have a significantly higher rollover rate than other types of vehicles. In a rollover crash, an unbelted person is significantly more likely to die than a person wearing a seat belt. As a reminder, make sure you and your passengers always wear seat belts.

For information on how to reduce the risk of rollover, read “Driving Guidelines” on page 138 of this manual and the *Off-Highway Driving Guidelines* section on page 157 . Failure to operate your vehicle correctly might result in loss of control or an accident.

Your Vehicle at a Glance

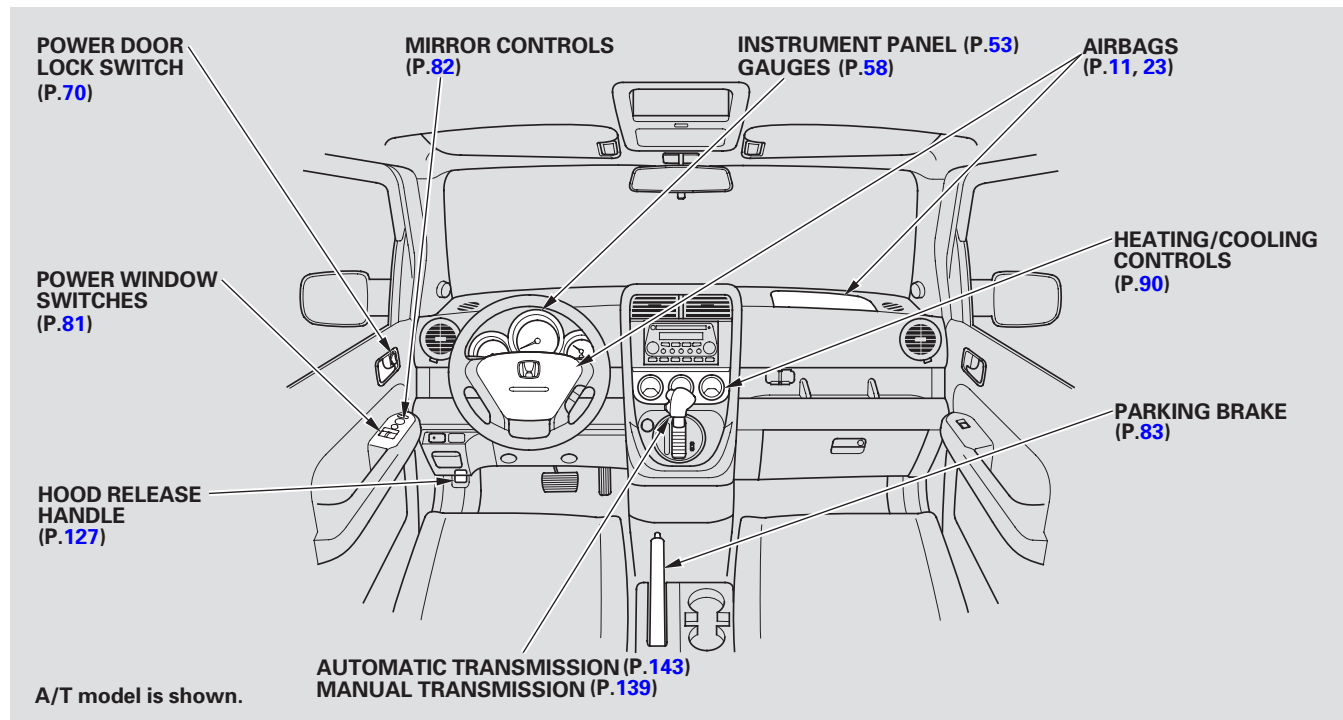

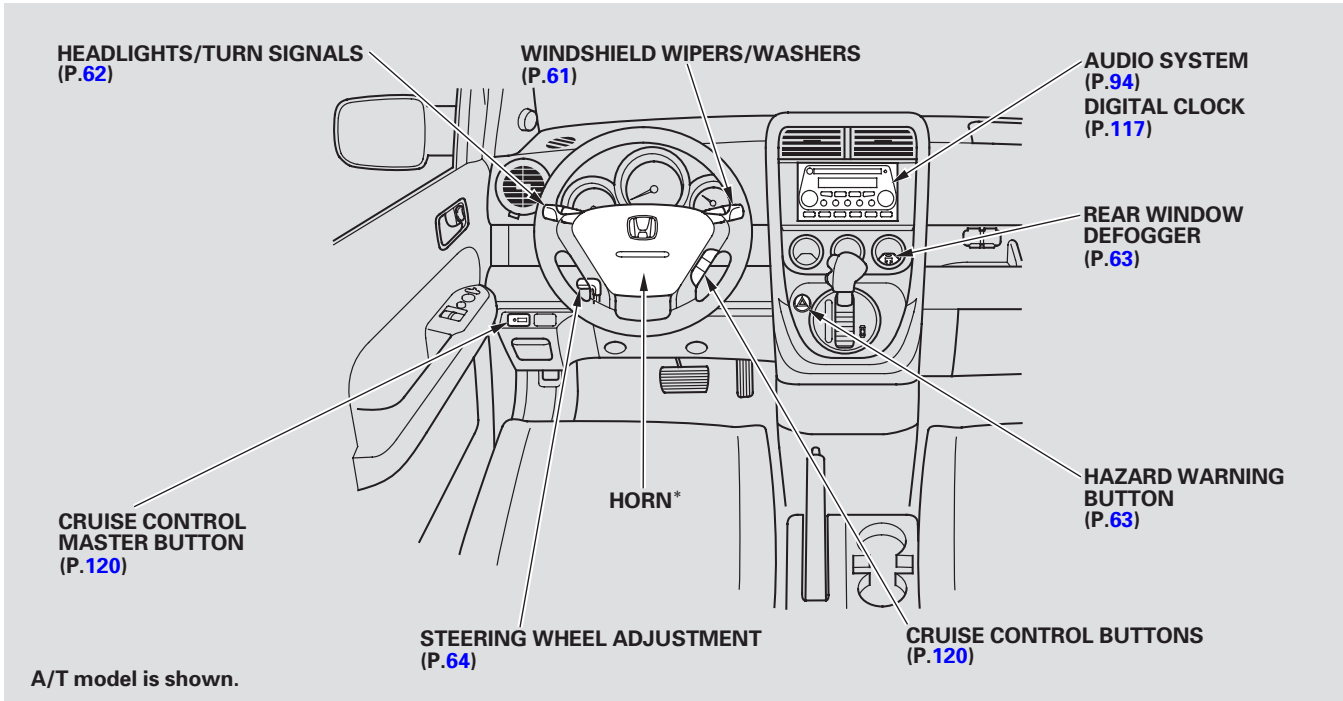

* : To use the horn, press the center pad of the steering wheel.

This section gives you important information about how to protect yourself and your passengers. It shows you how to use seat belts. It explains how your airbags work. And it tells you how to properly restrain infants and children in your vehicle.

- Important Safety Precautions 8
- Your Vehicle’s Safety Features..... 9
 - Seat Belts 10
 - Airbags..... 11
- Protecting Adults and Teens..... 12
 - 1. Close and Lock the Doors..... 12
 - 2. Adjust the Front Seats 12
 - 3. Adjust the Seat-Backs 14
 - 4. Adjust the Head Restraints 15
 - 5. Fasten and Position the Seat Belts..... 15
 - 6. Maintain a Proper Sitting Position 17
 - Advice for Pregnant Women..... 18
 - Additional Safety Precautions.... 19

- Additional Information About Your Seat Belts 20
- Seat Belt System Components... 20
- Lap/Shoulder Belt..... 20
- Automatic Seat Belt Tensioners..... 21
- Seat Belt Maintenance 21
- Additional Information About Your Airbags..... 23
- Airbag System Components..... 23
- How Your Front Airbags Work..... 24
- How Your Side Airbags Work.... 26
- How the SRS Indicator Works..... 27
- How the Side Airbag Off Indicator Works 28
- Airbag Service..... 28
- Additional Safety Precautions.... 29
- Protecting Children – General Guidelines..... 30
- All Children Must Be Restrained 30
- All Children Should Sit in a Back Seat..... 31

- The Passenger’s Front Airbag Poses Serious Risks 31
- If You Must Drive with Several Children 33
- If a Child Requires Close Attention 33
- Additional Safety Precautions... 34
- Protecting Infants and Small Children..... 35
- Protecting Infants 35
- Protecting Small Children 36
- Selecting a Child Seat..... 37
- Installing a Child Seat 38
 - With LATCH 39
 - With a Lap/Shoulder Belt 41
 - With a Tether 43
- Protecting Larger Children 44
- Checking Seat Belt Fit 44
- Using a Booster Seat 45
- When Can a Larger Child Sit in Front..... 45
- Additional Safety Precautions... 46
- Carbon Monoxide Hazard 47
- Safety Labels 48

Important Safety Precautions

You'll find many safety recommendations throughout this section, and throughout this manual. The recommendations on this page are the ones we consider to be the most important.

Always Wear Your Seat Belt

A seat belt is your best protection in all types of collisions. Airbags are designed to supplement seat belts, not replace them. So even though your vehicle is equipped with airbags, make sure you and your passengers always wear your seat belts, and wear them properly (see page 15).

Restrain All Children

Children age 12 and under should ride properly restrained in a back seat. Infants and small children should be restrained in a child seat. Larger children should use a booster seat and a lap/shoulder belt until they can use the belt properly without a booster (see pages 30 — 46).

Be Aware of Airbag Hazards

While airbags can save lives, they can cause serious or fatal injuries to occupants who sit too close to them, or are not properly restrained. Infants, young children, and short adults are at the greatest risk. Be sure to follow all instructions and warnings in this manual.

Don't Drink and Drive

Alcohol and driving don't mix. Even one drink can reduce your ability to respond to changing conditions, and your reaction time gets worse with

every additional drink. So don't drink and drive, and don't let your friends drink and drive, either.

Control Your Speed

Excessive speed is a major factor in crash injuries and deaths. Generally, the higher the speed, the greater the risk, but serious injuries can also occur at lower speeds. Never drive faster than is safe for current conditions, regardless of the maximum speed posted.

Keep Your Vehicle in Safe Condition

Having a tire blowout or a mechanical failure can be extremely hazardous. To reduce the possibility of such problems, check your tire pressures and condition frequently, and perform all regularly scheduled maintenance (see page 163).

Your Vehicle's Safety Features

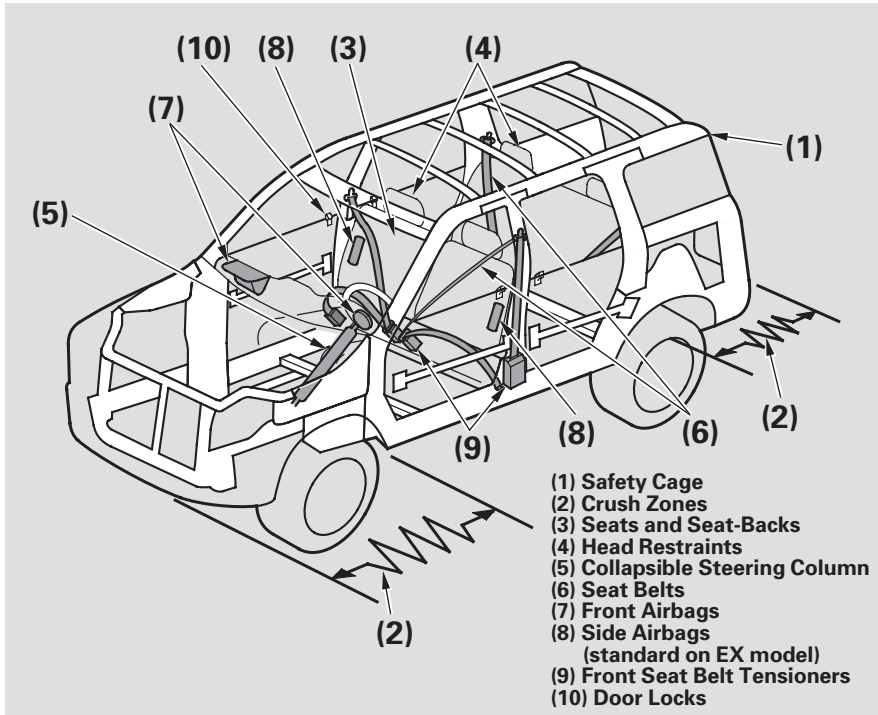

Your vehicle is equipped with many features that work together to protect you and your passengers during a crash.

Some features do not require any action on your part. These include a strong steel framework that forms a safety cage around the passenger compartment; front and rear crush zones; a collapsible steering column; and tensioners that tighten the front seat belts in a crash.

However, you and your passengers can't take full advantage of these features unless you remain sitting in a proper position and ***always wear your seat belts.*** In fact, some safety features can contribute to injuries if they are not used properly.

The following pages explain how you can take an active role in protecting yourself and your passengers.

Your Vehicle's Safety Features

Seat Belts

Your vehicle is equipped with seat belts in all seating positions.

Your seat belt system also includes an indicator on the instrument panel to remind you and your passengers to fasten your seat belts.

Why Wear Seat Belts

Seat belts are the single most effective safety device for adults and larger children. (Infants and smaller children must be properly restrained in child seats.)

Not wearing a seat belt properly increases the chance of serious injury or death in a crash, even though your vehicle has airbags.

In addition, most states and all Canadian provinces require you to wear seat belts.

WARNING

Not wearing a seat belt properly increases the chance of serious injury or death in a crash, even though your vehicle has airbags.

Be sure you and your passengers always wear seat belts and wear them properly.

When properly worn, seat belts:

- Keep you connected to the vehicle so you can take advantage of the vehicle's built-in safety features.
- Help protect you in almost every type of crash, including frontal, side, and rear impacts and rollovers.

- Help keep you from being thrown against the inside of the vehicle and against other occupants.
- Keep you from being thrown out of the vehicle.
- Help keep you in a good position should the airbags ever deploy. A good position reduces the risk of injury from an inflating airbag and allows you to get the best advantage from the airbag.

Of course, seat belts cannot completely protect you in every crash. But in most cases, seat belts can reduce your risk of serious injury.

What You Should Do:

Always wear your seat belt, and make sure you wear it properly.

Your Vehicle's Safety Features

Airbags

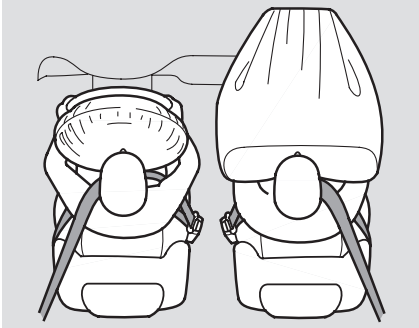

Your vehicle has a supplemental restraint system (SRS) with front airbags to help protect the heads and chests of the driver and a front seat passenger during a moderate to severe frontal collision (see page 24 for more information on how your front airbags work).

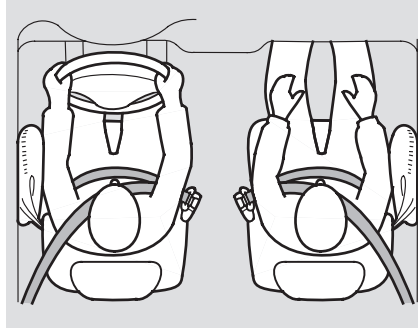

Standard on EX models
Your vehicle has side airbags to help protect the upper torso of the driver or a front seat passenger during a moderate to severe side impact (see page 26 for more information on how your side airbags work).

The most important things you need to know about your airbags are:

- **Airbags do not replace seat belts.** They are designed to supplement the seat belts.
- **Airbags offer no protection in rear impacts, or minor frontal or side collisions.**
- **Airbags can pose hazards.** To do their job, airbags must inflate with tremendous force. So while airbags help save lives, they can cause minor injuries or more serious or even fatal injuries if occupants are not properly restrained or sitting properly.

What you should do: Always wear your seat belt properly, and sit upright and as far back from the steering wheel as possible while allowing full control of the vehicle. A front passenger should move their seat as far back from the dashboard as possible.

Protecting Adults and Teens

The rest of this section gives more detailed information about how you can maximize your safety.

Remember, however, that no safety system can prevent all injuries or deaths that can occur in a severe crash, even when seat belts are properly worn and the airbags deploy.

Introduction

The following pages provide instructions on how to properly protect the driver, adult passengers, and teenage children who are large enough and mature enough to drive or ride in the front.

See pages [30](#) – [46](#) for important guidelines on how to properly protect infants, small children, and larger children who ride in your vehicle.

1. Close and Lock the Doors

After everyone has entered the vehicle, be sure the doors are closed and locked.



Your vehicle has a door monitor indicator on the instrument panel to indicate when a specific door or the tailgate or the hatch is not tightly closed.

Locking the doors reduces the chance of someone being thrown out of the vehicle during a crash and it helps prevent passengers from accidentally opening and falling out.

Locking the doors also helps prevent an outsider from unexpectedly opening a door when you come to a stop.

See page [70](#) for how to lock the doors, and page [57](#) for how the door monitor indicator works.

2. Adjust the Front Seats

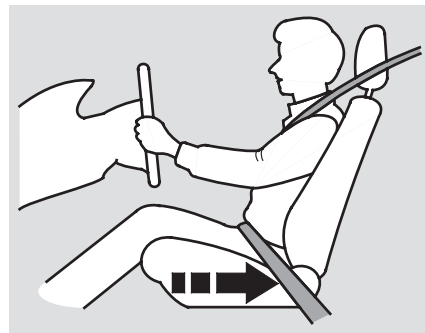

Adjust the driver's seat as far to the rear as possible while allowing you to maintain full control of the vehicle. Have a front passenger adjust their seat as far to the rear as possible.

If you sit too close to the steering wheel or dashboard, you can be seriously injured by an inflating front airbag, or by striking the steering wheel or dashboard.

The National Highway Traffic Safety Administration and Transport Canada recommend that drivers allow at least 10 inches (25 cm) between the center of the steering wheel and the chest.

If you cannot get far enough away from the steering wheel and still reach the controls, we recommend that you investigate whether some type of adaptive equipment may help.

⚠ WARNING

Sitting too close to a front airbag can result in serious injury or death if the front airbags inflate.

Always sit as far back from the front airbags as possible.

See page [73](#) for how to adjust the front seats.

Protecting Adults and Teens

3. Adjust the Seat-Backs

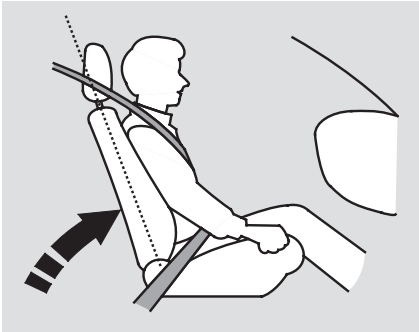

Adjust the driver's seat-back to a comfortable, upright position, leaving ample space between your chest and the airbag cover in the center of the steering wheel.

Passengers with adjustable seat-backs should also adjust their seat-back to a comfortable, upright position.

Reclining a seat-back so that the shoulder part of the belt no longer rests against the occupant's chest reduces the protective capability of the belt. It also increases the chance of sliding under the belt in a crash and being seriously injured. The farther a seat-back is reclined, the greater the risk of injury.

⚠ WARNING

Reclining the seat-back too far can result in serious injury or death in a crash.

Adjust the seat-back to an upright position, and sit well back in the seat.

See page [73](#) for how to adjust the seat-backs.

4. Adjust the Head Restraints

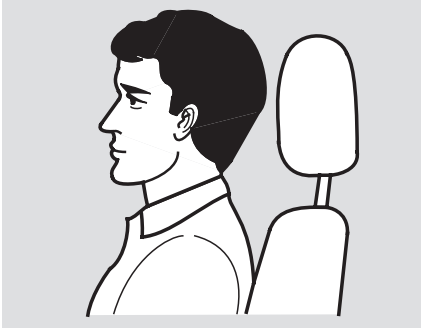

Adjust the driver's head restraint so the back of your head rests against the center of the restraint.

Have passengers with adjustable head restraints adjust their restraints properly as well. Taller persons should adjust their restraint as high as possible.

⚠ WARNING

Improperly positioning head restraints reduces their effectiveness and you can be seriously injured in a crash.

Make sure head restraints are in place and positioned properly before driving.

Properly adjusted head restraints will help protect occupants from whiplash and other crash injuries.

See page [75](#) for how to adjust the head restraints.

5. Fasten and Position the Seat Belts

Insert the latch plate into the buckle, then tug on the belt to make sure the belt is securely latched. Also check that the belt is not twisted, because a twisted belt can cause serious injuries in a crash.

CONTINUED

Protecting Adults and Teens



Position the lap part of the belt as low as possible across your hips, then pull up on the shoulder part of the belt so the lap part fits snugly. This lets your strong pelvic bones take the force of a crash and reduces the chance of internal injuries.

If necessary, pull up on the belt again to remove any slack, then check that the belt rests across the center of your chest and over your shoulder. This spreads the forces of a crash over the strongest bones in your upper body.

⚠ WARNING

Improperly positioning the seat belts can cause serious injury or death in a crash.

Make sure all seat belts are properly positioned before driving.

If the seat belt touches or crosses your neck, or if it crosses your arm instead of your shoulder, you need to adjust the seat belt anchor height.

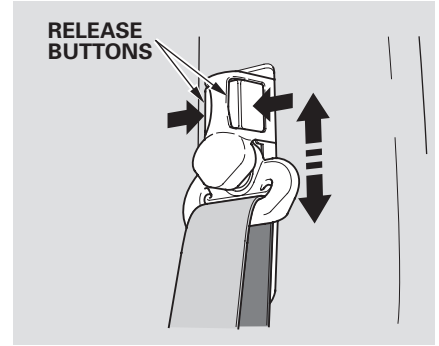

The front seats have adjustable seat belt anchors. To adjust the height of an anchor, press and hold the release buttons, and slide the anchor up or down as needed (it has four positions).

Never place the shoulder portion of a lap/shoulder belt under your arm or behind your back. This could cause very serious injuries in a crash.

If a seat belt does not seem to work properly, it may not protect the occupant in a crash.

No one should sit in a seat with an inoperative seat belt. Using a seat belt that is not working properly can result in serious injury or death. Have your dealer check the belt as soon as possible.

See page [20](#) for additional information about your seat belts and how to take care of them.

6. Maintain a Proper Sitting Position

After all occupants have adjusted their seats and put on seat belts, it is very important that they continue to sit upright, well back in their seats, with their feet on the floor, until the vehicle is parked and the engine is off.

Sitting improperly can increase the chance of injury during a crash. For example, if an occupant slouches, lies down, turns sideways, sits forward, leans forward or sideways, or puts one or both feet up, the chance of injury during a crash is greatly increased.

CONTINUED

Protecting Adults and Teens

In addition, an occupant who is out of position in the front seat can be seriously or fatally injured in a crash by striking interior parts of the vehicle or being struck by an inflating front airbag.

WARNING

Sitting improperly or out of position can result in serious injury or death in a crash.

Always sit upright, well back in the seat, with your feet on the floor.

Advice for Pregnant Women



If you are pregnant, the best way to protect yourself and your unborn child when driving or riding in a vehicle is to always wear a seat belt, and keep the lap part of the belt as low as possible across the hips.

When driving, remember to sit upright and adjust the seat as far back as possible while allowing full control of the vehicle. When riding as a front passenger, adjust the seat as far back as possible.

This will reduce the risk of injuries to both you and your unborn child that can be caused by a crash or an inflating front airbag.

Each time you have a checkup, ask your doctor if it's okay for you to drive.

Additional Safety Precautions

- **Never let passengers ride in the cargo area or on top of a folded-down back seat.** If they do, they could be very seriously injured in a crash.
- **Passengers should not stand up or change seats while the vehicle is moving.** A passenger who is not wearing a seat belt during a crash or emergency stop can be thrown against the inside of the vehicle, against other occupants, or out of the vehicle.
- **Two people should never use the same seat belt.** If they do, they could be very seriously injured in a crash.
- **Do not put any accessories on seat belts.** Devices intended to improve occupant comfort or reposition the shoulder part of a seat belt can severely compromise the protective capability of the seat belt and increase the chance of serious injury in a crash.
- **Do not place hard or sharp objects between yourself and a front airbag.** Carrying hard or sharp objects on your lap, or driving with a pipe or other sharp object in your mouth, can result in injuries if your front airbag inflates.
- **Do not attach or place objects on the front airbag covers.** Objects on the covers marked “SRS AIRBAG” could interfere with the proper operation of the airbags or be propelled inside the vehicle and hurt someone if the airbags inflate.
- **On models with side airbags, do not attach hard objects on or near a front door.** If a side airbag inflates, a cup holder or other hard object attached on or near the door could be propelled inside the vehicle and hurt someone.
- **Keep your hands and arms away from the airbag covers.** If your hands or arms are close to an airbag cover, they could be injured if the front airbag inflates.

Additional Information About Your Seat Belts

Seat Belt System Components

Your seat belt system includes lap/shoulder belts in all four seating positions. The front seat belts are also equipped with automatic seat belt tensioners.



The seat belt system includes an indicator on the instrument panel and a beeper to remind you to fasten your seat belt.

If you turn the ignition switch to the ON (II) position before fastening your seat belt, the beeper will sound, and the indicator will flash. If you do not fasten your seat belt before the beeper stops, the indicator will stop flashing but remains on.

If you continue driving without fastening your seat belt, the beeper will sound and the indicator will flash again at regular intervals.

Lap/Shoulder Belt

The lap/shoulder belt goes over your shoulder, across your chest, and across your hips.

To fasten the belt, insert the latch plate into the buckle, then tug on the belt to make sure the buckle is latched (see page 15 for how to properly position the belt).

To unlock the belt, press the red PRESS button on the buckle. Guide the belt across your body so that it retracts completely. After exiting the vehicle, be sure the belt is out of the way and will not get closed in the door.

All seat belts have an emergency locking retractor. In normal driving, the retractor lets you move freely in your seat while it keeps some tension on the belt. During a collision or sudden stop, the retractor automatically locks the belt to help

restrain your body.

The seat belts in all positions except the driver's have an additional locking mechanism that must be activated to secure a child seat (see page 41).

If the shoulder part of the belt is pulled all the way out, the locking mechanism will activate. The belt will retract, but it will not allow the passenger to move freely.

To deactivate the locking mechanism, unlatch the buckle and let the seat belt fully retract. To refasten the seat belt, pull it out only as far as needed.

Additional Information About Your Seat Belts

Automatic Seat Belt Tensioners

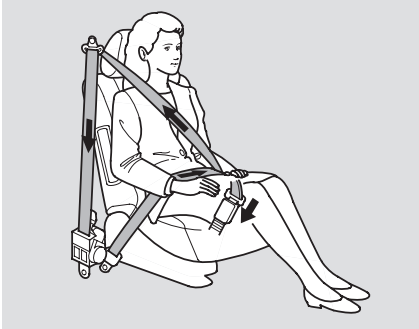

For added protection, the front seat belts are equipped with automatic seat belt tensioners. When activated, the tensioners immediately tighten the belts to help hold the driver and a front passenger in place.

The tensioners are designed to activate in any collision severe enough to cause front airbag inflation.

The tensioners can also be activated during a collision in which the front airbags *do not deploy*. In this case, the airbags would not be needed, but the additional restraint could be helpful.

When the tensioners are activated, the seat belts will remain tight until they are unbuckled in the normal manner.

If the front seat belt tensioners ever activate, they must be replaced as the belts will no longer retract properly.

Seat Belt Maintenance

For safety, you should check the condition of your seat belts regularly.

Pull each belt out fully, and look for frays, cuts, burns, and wear. Check that the latches work smoothly and the belts retract easily. If a belt does not retract easily, cleaning the belt may correct the problem (see page 185). Any belt that is not in good condition or working properly will not provide good protection and should be replaced as soon as possible.

Honda provides a lifetime warranty on seat belts for U.S. models. See your *Honda Warranty Information* booklet for details.

CONTINUED

Additional Information About Your Seat Belts

If a seat belt is worn during a crash, it must be replaced by the dealer. A belt that has been worn during a crash may not provide the same level of protection in a subsequent crash.

The dealer should also inspect the anchors for damage and replace them if needed. If the automatic seat belt tensioners activate during a crash, they must be replaced.

WARNING

Not checking or maintaining seat belts can result in serious injury or death if the seat belts do not work properly when needed.

Check your seat belts regularly and have any problem corrected as soon as possible.

Additional Information About Your Airbags

Airbag System Components

Your airbag system includes:

- Two SRS (supplemental restraint system) front airbags. The driver's airbag is stored in the center of the steering wheel; the front passenger's airbag is stored in the dashboard. Both are marked "SRS AIRBAG" (see page 24).
- On models equipped with two side airbags, one for the driver and one for a front passenger. The airbags are stored in the outer edges of the seat-backs. Both are marked "SIDE AIRBAG" (see page 26).
- Automatic seat belt tensioners (see page 21).
- Sensors that can detect a moderate to severe front impact, or side impact in models with side airbags.
- On models with side airbags, sensors that can detect whether a child is in the passenger's side airbag path and automatically turn the airbag off (see page 26).
- A sophisticated electronic system that continually monitors and records information about the sensors, the control unit, the airbag activators, the seat belt tensioners, and driver and front passenger seat belt use when the ignition switch is in the ON (II) position.
- An indicator on the instrument panel that alerts you to a possible problem with your airbags, sensors, or seat belt tensioners (see page 27).
- On models equipped with side airbags, an indicator on the dashboard that alerts you that the passenger's side airbag has been turned off (see page 28).
- Emergency backup power in case your vehicle's electrical system is disconnected in a crash.

Additional Information About Your Airbags

How Your Front Airbags Work

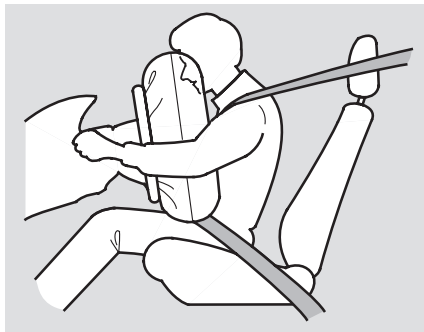

If you ever have a moderate to severe frontal collision, sensors will detect the vehicle's rapid deceleration.

If the rate of deceleration is high enough, the control unit will instantly inflate the driver's and front passenger's airbags, at the time and with the force needed.

During a frontal crash, your seat belt restrains your lower body and torso, and the front airbag helps protect your head and chest.

Although both airbags normally inflate within a split second of each other, it is possible for only one airbag to deploy.

This can happen if the severity of a collision is at the margin, or threshold, that determines whether or not the airbags will deploy. In such cases, the seat belt will provide sufficient protection, and the supplemental protection offered by the airbag would be minimal.

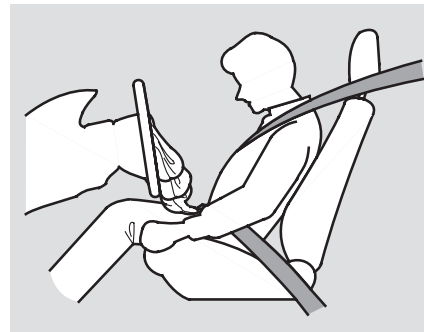

After inflating, the front airbags immediately deflate, so they won't interfere with the driver's visibility, or the ability to steer or operate other controls.

Additional Information About Your Airbags

The total time for inflation and deflation is one-tenth of a second, so fast that most occupants are not aware that the airbags deployed until they see them lying in their laps.

After a crash, you may see what looks like smoke. This is actually powder from the airbag's surface. Although the powder is not harmful, people with respiratory problems may experience some temporary discomfort. If this occurs, get out of the vehicle as soon as it is safe to do so.

Dual-Stage Airbags

Your front airbags are dual-stage airbags. This means they have two inflation stages that can be ignited sequentially or simultaneously, depending on crash severity.

In a *more severe* crash, both stages will ignite simultaneously to provide the quickest and greatest protection.

In a *less severe* crash, one stage will ignite first, then the second stage will ignite a split second later. This provides longer airbag inflation time with a little less force.

Dual-Threshold Airbags

Your front airbags are also dual-threshold airbags. Airbags with this feature have two deployment thresholds that depend on whether or not the occupant is wearing a seat belt.

If the occupant's belt is *not latched*, the airbag will deploy at a slightly lower threshold, because the occupant would need extra protection.

If the occupant's belt is *latched*, the airbag will deploy at a slightly higher threshold, when the airbag would be needed to supplement the protection provided by the seat belt.

Additional Information About Your Airbags

How Your Side Airbags Work

Standard on EX models

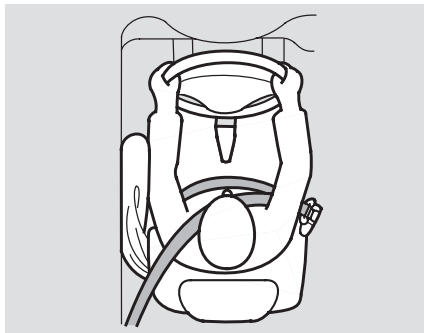

If you ever have a moderate to severe side impact, sensors will detect rapid deceleration and signal the control unit to instantly inflate either the driver's or the passenger's side airbag.

Only one airbag will deploy during a side impact. If the impact is on the passenger's side, the passenger's side airbag will deploy even if there is no passenger.

To get the best protection from the side airbags, front seat occupants should wear their seat belts and sit upright and well back in their seats.

Side Airbag Cutoff System

Your vehicle has a side airbag cutoff system designed primarily to protect a child riding in the front passenger's seat.

Although Honda does not encourage children to ride in front, if the sensors in the seat detect a child has leaned into the side airbag's deployment path, the airbag will shut off.

The side airbag may also shut off if a short adult leans sideways, or a larger adult slouches and leans sideways into the airbag's deployment path.

Objects placed on the front passenger seat can also cause the

side airbag to be shut off.

If the side airbag off indicator comes on (see page 28), have the passenger sit upright. Once the passenger is out of the airbag's deployment path, the system will turn the airbag back on, and the indicator will go out.

There will be some delay between the moment the passenger moves into or out of the airbag deployment path and when the indicator comes on or goes off.

A front seat passenger should not use a cushion or other object as a backrest. It may prevent the cutoff system from working properly.

Additional Information About Your Airbags

How the SRS Indicator Works



The SRS indicator alerts you to a potential problem with your airbags or seat belt tensioners.

When you turn the ignition switch to the ON (II) position, this indicator comes on briefly then goes off. This tells you the system is working properly.

If the indicator comes on at any other time, or does not come on at all, you should have the system checked by your dealer. For example:

- If the SRS indicator does not come on after you turn the ignition switch to the ON (II) position.
- If the indicator stays on after the engine starts.
- If the indicator comes on or flashes on and off while you drive.

If you see any of these indications, the airbags and seat belt tensioners may not work properly when you need them.

WARNING

Ignoring the SRS indicator can result in serious injury or death if the airbag systems or tensioners do not work properly.

Have your vehicle checked by a dealer as soon as possible if the SRS indicator alerts you to a possible problem.

Additional Information About Your Airbags

How the Side Airbag Off Indicator Works

Standard on U.S. EX models and Canadian Y package

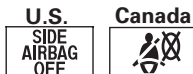

This indicator alerts you that the passenger's side airbag has been automatically shut off. It does **not** mean there is a problem with your side airbags.

When you turn the ignition switch to the ON (II) position, the indicator should come on briefly and go off (see page 55). If it doesn't come on, stays on, or comes on while driving without a passenger in the front seat, have the system checked.

Airbag Service

Your airbag systems are virtually maintenance free, and there are no parts you can safely service. However, you must have your vehicle serviced if:

- **An airbag ever inflates.** Any airbag that has deployed must be replaced along with the control unit and other related parts. If a front airbag inflates, the seat belt tensioners must also be replaced. Do not try to remove or replace any airbag by yourself. This must be done by a dealer or a knowledgeable body shop.

- **The SRS indicator alerts you to a problem.** Take your vehicle to an authorized dealer as soon as possible. If you ignore this indication, your airbags may not operate properly.

Additional Information About Your Airbags

Additional Safety Precautions

- **Do not attempt to deactivate your airbags.** Together, airbags and seat belts provide the best protection.
- **Do not tamper with airbag components or wiring for any reason.** Tampering could cause the airbags to deploy, possibly causing very serious injury.
- **Do not expose the front seat-backs to liquid.** If water or another liquid soaks into a seat-back, it can prevent the side airbag cutoff system from working properly.

Models with side airbags:

- **Do not cover or replace front seat-back covers without consulting your dealer.** Improperly replacing or covering front seat-back covers can prevent your side airbags from inflating during a side impact.

Protecting Children – General Guidelines



Children depend on adults to protect them. However, despite their best intentions, many adults do not know how to properly protect child passengers.

If you have children, or ever need to drive with a child in your vehicle, be sure to read this section. It begins with important general guidelines, then presents special information for infants, small children, and larger children.

All Children Must Be Restrained

Each year, many children are injured or killed in vehicle crashes because they are either unrestrained or not properly restrained. In fact, vehicle accidents are the number one cause of the death of children ages 12 and under.

To reduce the number of child deaths and injuries, every state and Canadian province requires that infants and children be properly restrained when they ride in a vehicle.

Infants and small children must be restrained in an approved child seat that is properly secured to the vehicle (see pages [35](#) – [43](#)).

⚠ WARNING

Children who are unrestrained or improperly restrained can be seriously injured or killed in a crash.

Any child too small for a seat belt should be properly restrained in a child seat. A larger child should be properly restrained with a seat belt and use a booster seat if necessary.

Larger children must be restrained with a lap/shoulder belt and ride on a booster seat until the seat belt fits them properly (see pages [44](#) – [46](#)).

All Children Should Sit in a Back Seat

According to accident statistics, children of all ages and sizes are safer when they are restrained in a back seat. The National Highway Traffic Safety Administration and Transport Canada recommend that all children age 12 and under be properly restrained in a back seat. Some states have laws restricting where children may ride.

Children who ride in back are less likely to be injured by striking interior vehicle parts during a collision or hard braking. Also, children cannot be injured by an inflating front airbag when they ride in the back.

The Passenger's Front Airbag Poses Serious Risks

Front airbags have been designed to help protect adults in a moderate to severe frontal collision. To do this, the passenger's front airbag is quite large, and it can inflate with enough force to cause very serious injuries.

Infants

Never put a rear-facing child seat in the front seat of a vehicle equipped with a passenger's front airbag. If the airbag inflates, it can hit the back of the child seat with enough force to kill or very seriously injure an infant.

Small Children

Placing a forward-facing child seat in the front seat of a vehicle equipped with a passenger's front airbag can be hazardous. If the vehicle seat is too far forward, or the child's head is thrown forward during a collision, an inflating front airbag can strike the child with enough force to kill or very seriously injure a small child.

Larger Children

Children who have outgrown child seats are also at risk of being injured or killed by an inflating passenger's front airbag. Whenever possible, larger children should sit in the back seat, on a booster seat if needed, and be properly restrained with a seat belt (see page 44 for important information about protecting larger children).

CONTINUED

Protecting Children – General Guidelines

To remind you of the passenger's front airbag hazards, and that children must be properly restrained in a back seat, your vehicle has warning labels on the dashboard (U.S. models) and on the front visors. Please read and follow the instructions on these labels.

U.S. Models

	WARNING
	DEATH or SERIOUS INJURY can occur <ul style="list-style-type: none">• Children 12 and under can be killed by the air bag• The BACK SEAT is the SAFEST place for children• NEVER put a rear-facing child seat in the front• Sit as far back as possible from the air bag• ALWAYS use SEAT BELTS and CHILD RESTRAINTS

	WARNING
Children Can Be KILLED or INJURED by Passenger Air Bag	
<ul style="list-style-type: none">• The back seat is the safest place for children 12 and under.• Make sure all children use seat belts or child seats.	
To be removed by owner only.	

Canadian Models

- CAUTION**
TO AVOID SERIOUS INJURY:
- FOR MAXIMUM SAFETY PROTECTION IN ALL TYPES OF CRASHES, YOU MUST ALWAYS WEAR YOUR SAFETY BELT.
 - DO NOT INSTALL REARWARD-FACING CHILD SEATS IN ANY FRONT PASSENGER SEAT POSITION.
 - DO NOT SIT OR LEAN UNNECESSARILY CLOSE TO THE AIR BAG.
 - DO NOT PLACE ANY OBJECTS OVER THE AIR BAG OR BETWEEN THE AIR BAG AND YOURSELF.
 - SEE THE OWNER'S MANUAL FOR FURTHER INFORMATION AND EXPLANATIONS.

- PRECAUTIONS:**
- POUR EVITER DES BLESSURES GRAVES:
- POUR PROFITER D'UNE PROTECTION MAXIMALE LORS D'UNE COLLISION BOUCLEZ TOUJOURS VOTRE CEINTURE DE SECURITE.
 - N'INSTALLEZ JAMAIS UN SIEGE POUR ENFANTS FAISANT FACE A L'ARRIERE SUR LE SIEGE DU PASSAGER AVANT.
 - NE VOUS APPUYEZ PAS ET NE VOUS ASSOYEZ PAS PRES DU COUSSIN GONFLABLE.
 - NE DEPOSEZ AUCUN OBJET SUR LE COUSSIN GONFLABLE OU ENTRE LE COUSSIN GONFLABLE ET VOUS.
 - LISEZ LE GUIDE UTILISATEUR POUR DE PLUS AMPLES RENSEIGNEMENTS.

If You Must Drive with Several Children

Your vehicle has two back seats where children can be properly restrained. If you ever have to carry three children, and a child must ride in front:

- Place the largest child in the front seat, provided the child is large enough to wear the lap/shoulder belt properly (see page 44).
- Move the vehicle seat as far to the rear as possible (see page 73).
- Have the child sit upright and well back in the seat (see page 17).
- Make sure the seat belt is properly positioned and secured (see page 15).

If a Child Requires Close Attention

Many parents say they prefer to put an infant or a small child in the front passenger seat so they can watch the child, or because the child requires attention.

Placing a child in the front seat exposes the child to hazards in a frontal collision, and paying close attention to a child distracts the driver from the important tasks of driving, placing both of you at risk.

If a child requires physical attention or frequent visual contact, we strongly recommend that another adult ride with the child in the back seat. The back seat is far safer for a child than the front.

Protecting Children – General Guidelines

Additional Safety Precautions

- **Never hold an infant or child on your lap.** If you are not wearing a seat belt in crash, you could be thrown forward and crush the child against the dashboard or a seat-back. If you are wearing a seat belt, the child can be torn from your arms and be seriously hurt or killed.
- **Never put a seat belt over yourself and a child.** During a crash, the belt could press deep into the child and cause serious or fatal injuries.
- **Never let two children use the same seat belt.** If they do, they could be very seriously injured in a crash.

- **Do not leave children alone in a vehicle.** Leaving children without adult supervision is illegal in most states and Canadian provinces, and can be very hazardous.

For example, infants and small children left in a vehicle on a hot day can die from heatstroke. A child left alone with the key in the ignition switch can accidentally set the vehicle in motion, possibly injuring themselves or others.

- **Lock all doors, the tailgate and the hatch when your vehicle is not in use.** Children who play in vehicles can accidentally get trapped inside. Teach your children not to play in or around vehicles.
- **Keep vehicle keys and remote transmitters (on some models) out of the reach of children.** Even very young children learn how to unlock vehicle doors, turn on the ignition, and open the tailgate or hatch, which can lead to accidental injury or death.

Protecting Infants

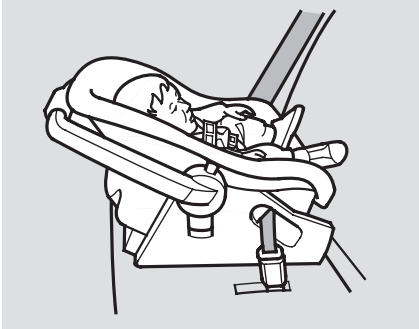

Child Seat Type

An infant must be properly restrained in a rear-facing, reclining child seat until the child reaches the seat maker's weight or height limit for the seat, and the child is at least one year old.

Only a rear-facing child seat provides proper support for a baby's head, neck, and back.

Two types of seats may be used: a seat designed exclusively for infants, or a convertible seat used in the rear-facing, reclining mode.

Do not put a rear-facing child seat in a forward-facing position. If placed facing forward, an infant could be very seriously injured during a frontal collision.

⚠ WARNING

Placing a rear-facing child seat in the front seat can result in serious injury or death if the passenger's front airbag inflates.

Always place a rear-facing child seat in the back seat, not the front.

Child Seat Placement

A rear-facing child seat can be placed in any seating position in the back seat, but not in the front. **Never put a rear-facing child seat in the front seat.**

If the passenger's front airbag inflates, it can hit the back of the child seat with enough force to kill or seriously injure an infant.

When properly installed, a rear-facing child seat may prevent the driver or a front passenger from moving their seat as far back as recommended, or from locking their seat-back in the desired position.

CONTINUED

Protecting Infants and Small Children

In either situation, we strongly recommend that you install the child seat directly behind the front passenger seat, move the seat as far forward as needed, and leave it unoccupied. Or you may wish to get a smaller rear-facing child seat.

Protecting Small Children



Child Seat Type

A child who is at least 1 year old, and who fits within the child seat maker's weight and height limits, should be restrained in a forward-facing, upright child seat.

Of the different seats available, we recommend those that have a five-point harness system as shown.

We also recommend that a small child use the child seat as long as possible, until the child reaches the weight or height limit for the seat.

Child Seat Placement

We strongly recommend placing a forward-facing child seat in a back seat, not the front.

Placing a forward-facing child seat in the front seat of a vehicle equipped with a passenger's airbag can be hazardous. If the vehicle seat is too far forward, or the child's head is thrown forward during a collision, an inflating airbag can strike the child with enough force to cause very serious or fatal injuries.

Protecting Infants and Small Children, Selecting a Child Seat

If it is necessary to put a forward-facing child seat in the front, move the vehicle seat as far to the rear as possible, and be sure the child seat is firmly secured to the vehicle and the child is properly strapped in the seat.

WARNING

Placing a forward-facing child seat in the front seat can result in serious injury or death if the front airbag inflates.

If you must place a forward-facing child seat in front, move the vehicle seat as far back as possible, and properly restrain the child.

Selecting a Child Seat

When buying a child seat, you need to choose either a conventional child seat, or one designed for use with the lower anchors and tethers for children (LATCH) system.

Conventional child seats must be secured to a vehicle with a seat belt, whereas LATCH-compatible seats are secured by attaching the seat to hardware built into the two second row seats.

Since LATCH-compatible child seats are easier to install and reduce the possibility of improper installation, we recommend selecting this style.

We also recommend selecting a LATCH-compatible seat with a rigid, rather than a flexible, anchor (see page 39).

In seating positions and vehicles not equipped with LATCH, a LATCH-compatible child seat can be installed using a seat belt.

Whatever type of seat you choose, to provide proper protection, a child seat should meet three requirements:

1. ***The child seat should meet U.S. or Canadian Motor Vehicle Safety Standard 213.*** Look for FMVSS 213 or CMVSS 213 on the box.
2. ***The child seat should be of the proper type and size to fit the child.*** Rear-facing for infants, forward-facing for small children.

CONTINUED

Selecting a Child Seat, Installing a Child Seat

3. *The child seat should fit the vehicle seating position (or positions) where it will be used.*

Before purchasing a conventional child seat, or using a previously purchased one, we recommend that you test the seat in the specific vehicle seating position or positions where the seat will be used.

Installing a Child Seat

After selecting a proper child seat and a good place to install the seat, there are three main steps in installing the seat:

1. ***Properly secure the child seat to the vehicle.*** All child seats must be secured to the vehicle with the lap part of a lap/shoulder belt or with the LATCH (lower anchors and tethers for children) system. A child whose seat is not properly secured to the vehicle can be endangered in a crash.
2. ***Make sure the child seat is firmly secured.*** After installing a child seat, push and pull the seat forward and from side-to-side to verify that it is secure.

A child seat secured with a seat belt should be installed as firmly as possible. However, it does not need to be “rock solid.” Some side-to-side

movement can be expected and should not reduce the child seat’s effectiveness.

If the child seat is not secure, try installing it in a different seating position, or use a different style of child seat that can be firmly secured.

3. ***Secure the child in the child seat.*** Make sure the child is properly strapped in the child seat according to the child seat maker’s instructions. A child who is not properly secured in a child seat can be seriously injured in a crash.

The following pages provide guidelines on how to properly install a child seat. A forward-facing child seat is used in all examples, but the instructions are the same for rear-facing child seats.

Installing a Child Seat with LATCH

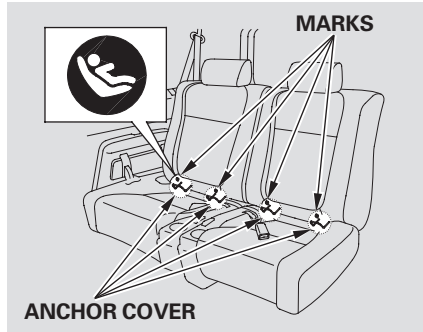

Your vehicle is equipped with LATCH (lower anchors and tethers for children) in the rear seats. The lower anchors are located between the seat-back and seat bottom, and are to be used only with a child seat designed for use with LATCH. The location of each lower anchor is marked with a small button above the point.

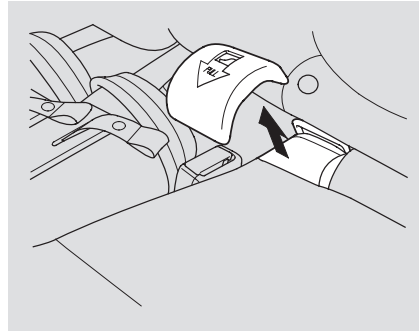

To install a LATCH-compatible child seat:

1. Remove both anchor covers by pulling forward.
2. Make sure there are no objects near the anchors that could prevent a secure connection between the child seat and the anchors.

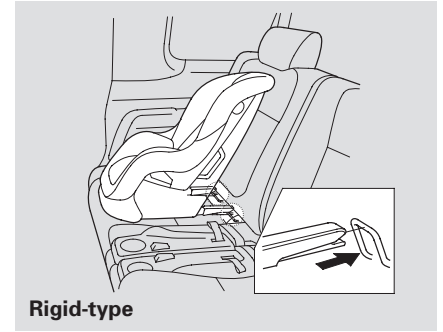

3. Place the child seat on the vehicle seat, then attach the seat to the lower anchors according to the child seat maker's instructions.

Some LATCH-compatible seats have a rigid-type connector as shown above.

CONTINUED

Installing a Child Seat

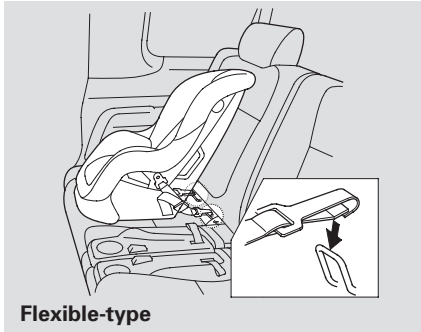

Other LATCH-compatible seats have a flexible-type connector as shown above.

4. Whatever type you have, follow the child seat maker's instructions for adjusting or tightening the fit.

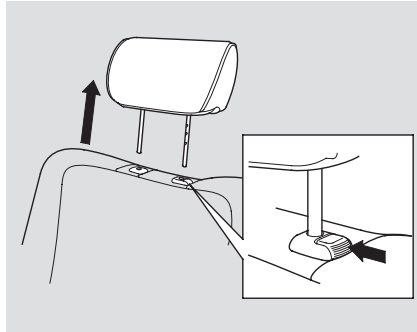

5. Remove the head restraint (see page 75). Make sure the removed head restraints are secured in the cargo area, and reinstalled when the child seat is removed.

6. Route the tether strap over the top of the seat-back, making sure the strap is not twisted.

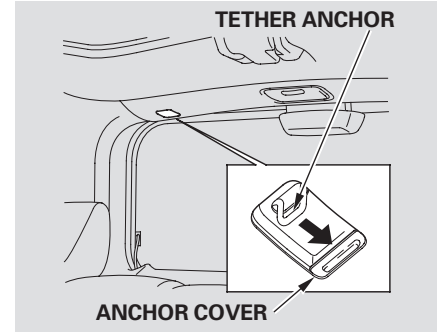

7. Slide the anchor cover open.

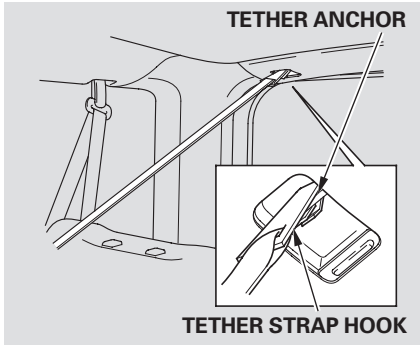

8. Attach the tether strap hook to the tether anchor, then tighten the strap as instructed by the child seat maker.
9. Push and pull the child seat forward and from side-to-side to verify that it is secure.

Installing a Child Seat with a Lap/Shoulder Belt

When not using the LATCH system, all child seats must be secured to the vehicle with the lap part of a lap/shoulder belt.

In addition, the lap/shoulder belts in all seating positions except the driver's have a locking mechanism that must be activated to secure a child seat.

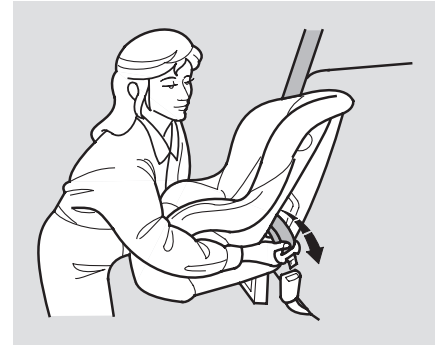

1. With the child seat in the desired seating position, route the belt through the child seat according to the seat maker's instructions, then insert the latch plate into the buckle.

CONTINUED

Installing a Child Seat

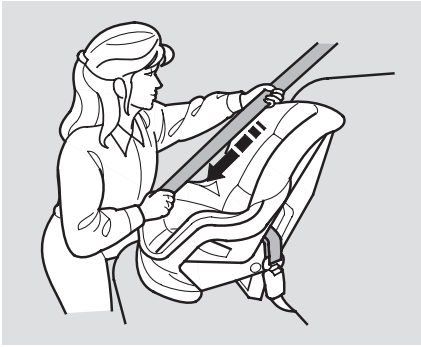

2. To activate the lockable retractor, slowly pull the shoulder part of the belt all the way out until it stops, then let the belt feed back into the retractor.
3. After the belt has retracted, tug on it. If the belt is locked, you will not be able to pull it out. If you can pull the belt out, it is not locked, and you will need to repeat these steps.



4. After confirming that the belt is locked, grab the shoulder part of the belt near the buckle, and pull up to remove any slack from the lap part of the belt. Remember, if the lap part of the belt is not tight, the child seat will not be secure.

To remove slack, it may help to put weight on the child seat, or push on the back of the seat while pulling up on the belt.

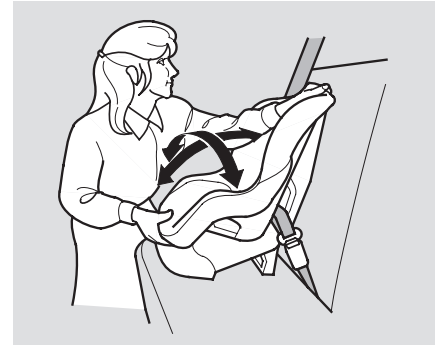

5. Push and pull the child seat forward and from side-to-side to verify that it is secure enough to stay upright during normal driving maneuvers. If the child seat is not secure, unlatch the belt, allow it to retract fully, then repeat these steps.
To deactivate the locking mechanism and remove a child seat, unlatch the buckle, unroute the seat belt, and let the belt fully retract.

Installing a Child Seat with a Tether

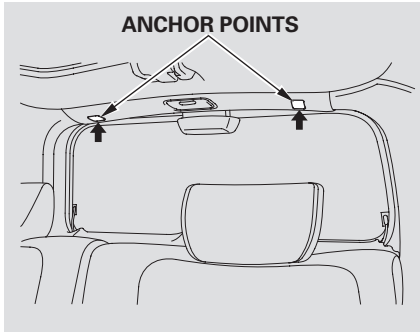

A child seat with a tether can be installed in either back seat, using one of the anchor points shown above.

Since a tether can provide additional security to the lap/shoulder belt installation, we recommend using a tether whenever one is required or available.

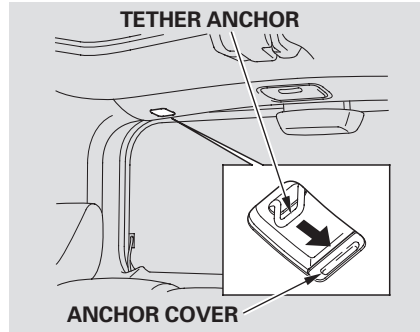

1. After securing the child seat in the desired position (see page 41), remove the head restraint (see page 75), then route the tether strap over the top of the seat-back.
2. Slide the anchor cover open as shown.

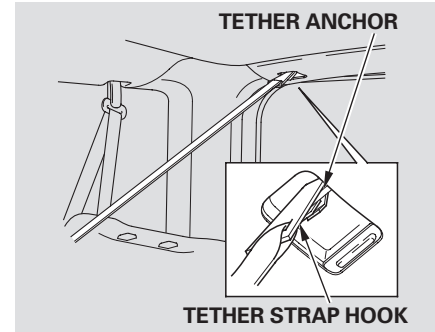

3. Attach the tether strap hook to the anchor, making sure the strap is not twisted.
4. Tighten the strap according to the seat maker's instructions. Make sure the removed head restraint is secured in the cargo area. Reinstall the head restraint in place when you remove the child seat.

Protecting Larger Children

When a child reaches the recommended weight or height limit for a forward-facing child seat, the child should sit in a back seat on a booster seat and wear a lap/shoulder belt.

The following pages give instructions on how to check proper seat belt fit, what kind of booster seat to use if one is needed, and important precautions for a child who must sit in front.

⚠ WARNING

Allowing a child age 12 or under to sit in front can result in injury or death if the passenger's front airbag inflates.

If a larger child must ride in front, move the vehicle seat as far back as possible, use a booster seat if needed, have the child sit up properly and wear the seat belt properly.

Checking Seat Belt Fit



To determine if a lap/shoulder belt properly fits a child, have the child put on the seat belt, then ask yourself:

1. Does the child sit all the way back against the seat?
2. Do the child's knees bend comfortably over the edge of the seat?

3. Does the shoulder belt cross between the child's neck and arm?
4. Is the lap part of the belt as low as possible, touching the child's thighs?
5. Will the child be able to stay seated like this for the whole trip?

If you answer yes to all these questions, the child is ready to wear the lap/shoulder belt correctly. If you answer no to any question, the child needs to ride on a booster seat.

Using a Booster Seat

A child who has outgrown a forward-facing child seat should ride in a back seat and use a booster seat until the lap/shoulder belt fits them properly without the booster.

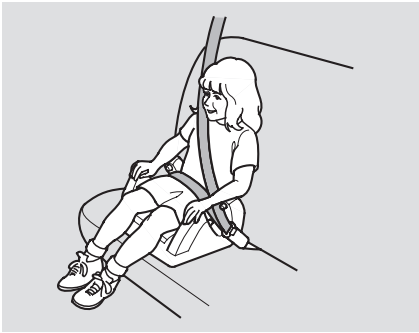

Some states and Canadian provinces also require children to use a booster seat until they reach a given age or weight (e.g., 6 years or 60 lbs). Be sure to check current laws in the states or provinces where you intend to drive.

Booster seats can be high-back or low-back. Whichever style you select, make sure the booster meets federal safety standards and that you follow the booster seat maker's instructions.

If a child who uses a booster seat must ride in front, move the vehicle seat as far back as possible and be sure the child is wearing the seat belt properly.

A child may continue using a booster seat until the tops of their ears are even with the top of the vehicle's or booster's seat-back. A child of this height should be tall enough to use the lap/shoulder belt without a booster seat.

When Can a Larger Child Sit in Front

The National Highway Traffic Safety Administration and Transport Canada recommend that all children age 12 and under be properly restrained in the back seat.

If the passenger's front airbag inflates in a moderate to severe frontal collision, the airbag can cause serious injuries to a child who is unrestrained, improperly restrained, sitting too close to the airbag, or out of position.

A side airbag also poses risks. If any part of a larger child's body is in the path of a deploying side airbag, the child could receive possibly serious injuries.

CONTINUED

Protecting Larger Children

Of course, children vary widely. And while age may be one indicator of when a child can safely ride in front, there are other important factors you should consider.

Maturity

To safely ride in front, a child must be able to follow the rules, including sitting properly, and wearing the seat belt properly throughout a ride.

Physical Size

Physically, a child must be large enough for the lap/shoulder belt to properly fit (see page 44). If the seat belt does not fit properly, with or without the child sitting on a booster seat, the child should not sit in front.

If you decide that a child can safely ride up front, be sure to:

- Carefully read the owner's manual, and make sure you understand all seat belt instructions and all safety information.
- Move the vehicle seat to the rear-most position.
- Have the child sit up straight, back against the seat, and feet on or near the floor.
- Check that the child's seat belt is properly and securely positioned.
- Supervise the child. Even mature children sometimes need to be reminded to fasten the seat belts or sit properly.

Additional Safety Precautions

- ***Do not let a child wear a seat belt across the neck.*** This could result in serious neck injuries during a crash.
- ***Do not let a child put the shoulder part of a seat belt behind the back or under the arm.*** This could cause very serious injuries during a crash. It also increases the chance that the child will slide under the belt in a crash and be injured.
- ***Two children should never use the same seat belt.*** If they do, they could be very seriously injured in a crash.
- ***Do not put any accessories on a seat belt.*** Devices intended to improve a child's comfort or reposition the shoulder part of a seat belt can make the belt less effective and increase the chance of serious injury in a crash.

Your vehicle's exhaust contains carbon monoxide gas. You should have no problem with carbon monoxide entering the vehicle in normal driving if you maintain your vehicle properly.

Have the exhaust system inspected for leaks whenever:

- The vehicle is raised for an oil change.
- You notice a change in the sound of the exhaust.
- The vehicle was in an accident that may have damaged the underside.

WARNING

Carbon monoxide gas is toxic. Breathing it can cause unconsciousness and even kill you.

Avoid any enclosed areas or activities that expose you to carbon monoxide.

High levels of carbon monoxide can collect rapidly in enclosed areas, such as a garage. Do not run the engine with the garage door closed. Even with the door open, run the engine only long enough to move the vehicle out of the garage.

With the tailgate or hatch open, air flow can pull exhaust gas into your vehicle's interior and create a hazardous condition. If you must drive with the tailgate or hatch open, open all the windows and set the heating and cooling system as shown below.

If you must sit in your parked vehicle with the engine running, even in an unconfined area, adjust the heating and cooling system as follows:

1. Select the fresh air mode.
2. Select the  mode.
3. Turn the fan on high speed.
4. Set the temperature control to a comfortable setting.

Safety Labels

These labels are in the locations shown. They warn you of potential hazards that could cause serious injury. Read these labels carefully. If a label comes off or becomes hard to read, contact your dealer for a replacement.

DASHBOARD

U.S. models only

▲ WARNING

Children Can Be KILLED or INJURED by Passenger Air Bag

- The back seat is the safest place for children 12 and under.
- Make sure all children use seat belts or child seats.

To be removed by owner only.

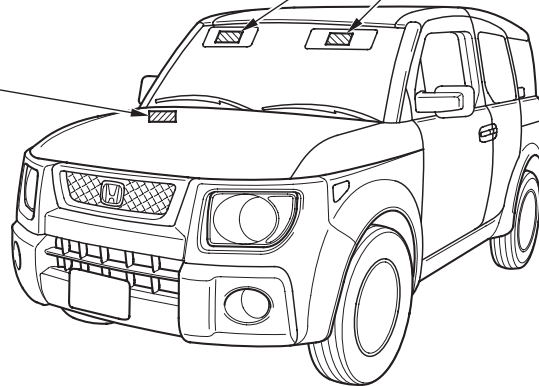

SUN VISOR

U.S. models

▲ WARNING

DEATH or SERIOUS INJURY can occur



- Children 12 and under can be killed by the air bag
- The **BACK SEAT** is the **SAFEST** place for children
- NEVER put a rear-facing child seat in the front
- Sit as far back as possible from the air bag
- ALWAYS use **SEAT BELTS** and **CHILD RESTRAINTS**

Canadian models

<p>CAUTION</p> <ul style="list-style-type: none"> • TO AVOID SERIOUS INJURY, ALWAYS WEAR YOUR SEAT BELT. • DO NOT OPERATE IN A POLICE VEHICLE. • DO NOT OPERATE IN AN OFFICIAL VEHICLE. • DO NOT OPERATE IN A VEHICLE WHERE IT IS PROHIBITED BY LAW. • DO NOT OPERATE IN A VEHICLE WHERE IT IS PROHIBITED BY LOCAL, STATE, FEDERAL OR INTERNATIONAL REGULATIONS. • DO NOT OPERATE IN A VEHICLE WHERE IT IS PROHIBITED BY LOCAL, STATE, FEDERAL OR INTERNATIONAL REGULATIONS. 	<p>PRECAUTIONS</p> <ul style="list-style-type: none"> • DO NOT OPERATE IN A VEHICLE WHERE IT IS PROHIBITED BY LOCAL, STATE, FEDERAL OR INTERNATIONAL REGULATIONS. • DO NOT OPERATE IN A VEHICLE WHERE IT IS PROHIBITED BY LOCAL, STATE, FEDERAL OR INTERNATIONAL REGULATIONS. • DO NOT OPERATE IN A VEHICLE WHERE IT IS PROHIBITED BY LOCAL, STATE, FEDERAL OR INTERNATIONAL REGULATIONS. • DO NOT OPERATE IN A VEHICLE WHERE IT IS PROHIBITED BY LOCAL, STATE, FEDERAL OR INTERNATIONAL REGULATIONS.
---	--

U.S. models only

▲ WARNING: HIGHER ROLLOVER RISK

	<p>Avoid Abrupt Maneuvers and Excessive Speed.</p> <p>Always Buckle Up.</p> <p>See Owner's Manual For Further Information.</p>	
---	--	---

HOOD

On models without side airbags

▲WARNING

The airbag inflator is explosive and, if accidentally deployed, can seriously hurt you. Follow Service Manual instructions carefully.

▲ATTENTION

Le gonfleur SRS est explosible, et s'il se déploie accidentellement, il risque de provoquer des blessures graves ou de tuer. Suivre attentivement les instructions du manuel d'entretien.

On models with side airbags

▲WARNING

Accidental deployment can seriously hurt or kill you. Follow Service Manual instructions carefully.

▲ATTENTION

Un déploiement accidentel risque de causer de graves blessures, voire mort. Suivre attentivement les instructions du manuel de réparation.

RADIATOR CAP

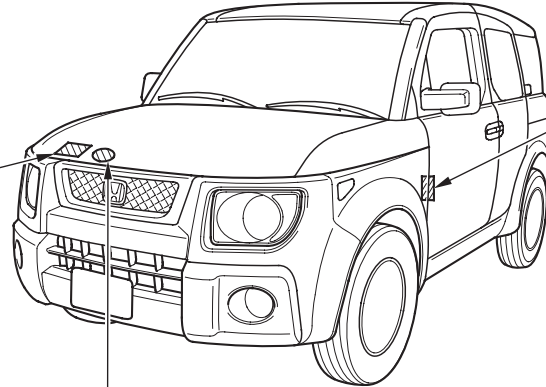

On models with side airbags

SIDE AIRBAG (A8)

- This car is equipped with side airbags in the driver's and passenger's seat.
- Do not lean against the door.
- See owner's manual for more information.

SIDE AIRBAG (C8)

- This car is equipped with side airbags in the driver's and passenger's seat.
- Do not lean against the door.
- See owner's manual for more information.

COUSSIN GONFLABLE LATÉRAL

- Cette voiture est équipée de coussins gonflables latéraux dans les sièges du conducteur et du passager.
- Ne vous appuyez pas sur la porte.
- Consultez le Manuel du propriétaire pour en savoir plus.

This section gives information about the controls and displays that contribute to the daily operation of your vehicle. All the essential controls are within easy reach.

Control Locations	52	Seats	73
Instrument Panel	53	Seat Adjustments.....	73
Instrument Panel Indicators.....	54	Driver's Seat Height	
Gauges	58	Adjustment	74
Trip Meter	58	Front Seat Armrests.....	74
Odometer.....	58	Head Restraints	75
Fuel Gauge	59	Rear Seat Access	75
Check Fuel Cap Indicator.....	59	Reclining the Front Seats	76
Temperature Gauge.....	59	Folding the Rear Seats.....	77
Controls Near the Steering		Removing the Rear Seats	79
Wheel	60	Power Windows	81
Windshield Wipers and Washers ..	61	Mirrors.....	82
Turn Signal and Headlights.....	62	Adjusting the Power Mirrors	82
Instrument Panel Brightness	63	Rear Windows	83
Hazard Warning Button.....	63	Parking Brake	83
Rear Window Defogger	63	Skylight	83
Steering Wheel Adjustment	64	Interior Convenience Items.....	86
Keys and Locks.....	65	Beverage Holders.....	87
Immobilizer System.....	66	Accessory Power Sockets.....	87
Remote Transmitter	67	Glove Box	87
Ignition Switch	69	Interior Lights.....	88
Door Locks	70	Ceiling Light.....	88
Power Door Locks.....	70	Cargo Area Light	88
Rear Doors	70	Spotlights.....	88
Hatch.....	71	Ignition Switch Light.....	88
Tailgate	72		

Control Locations

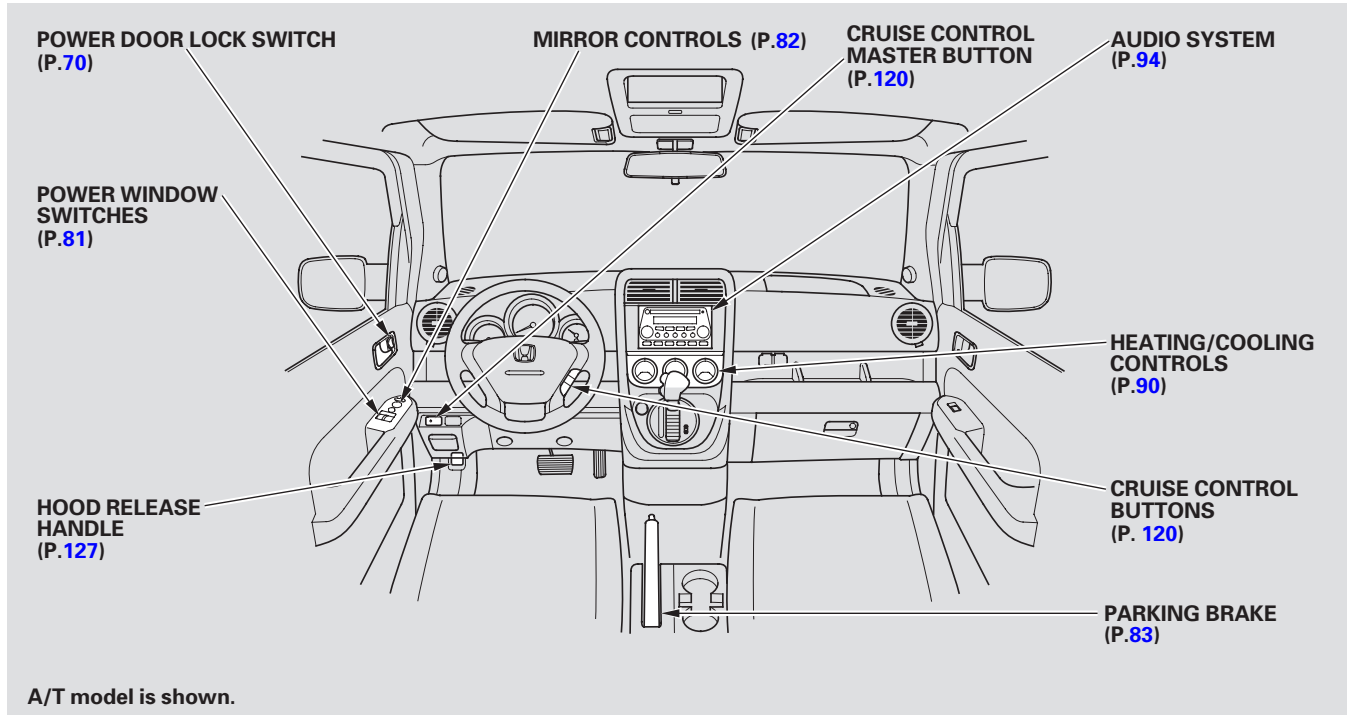

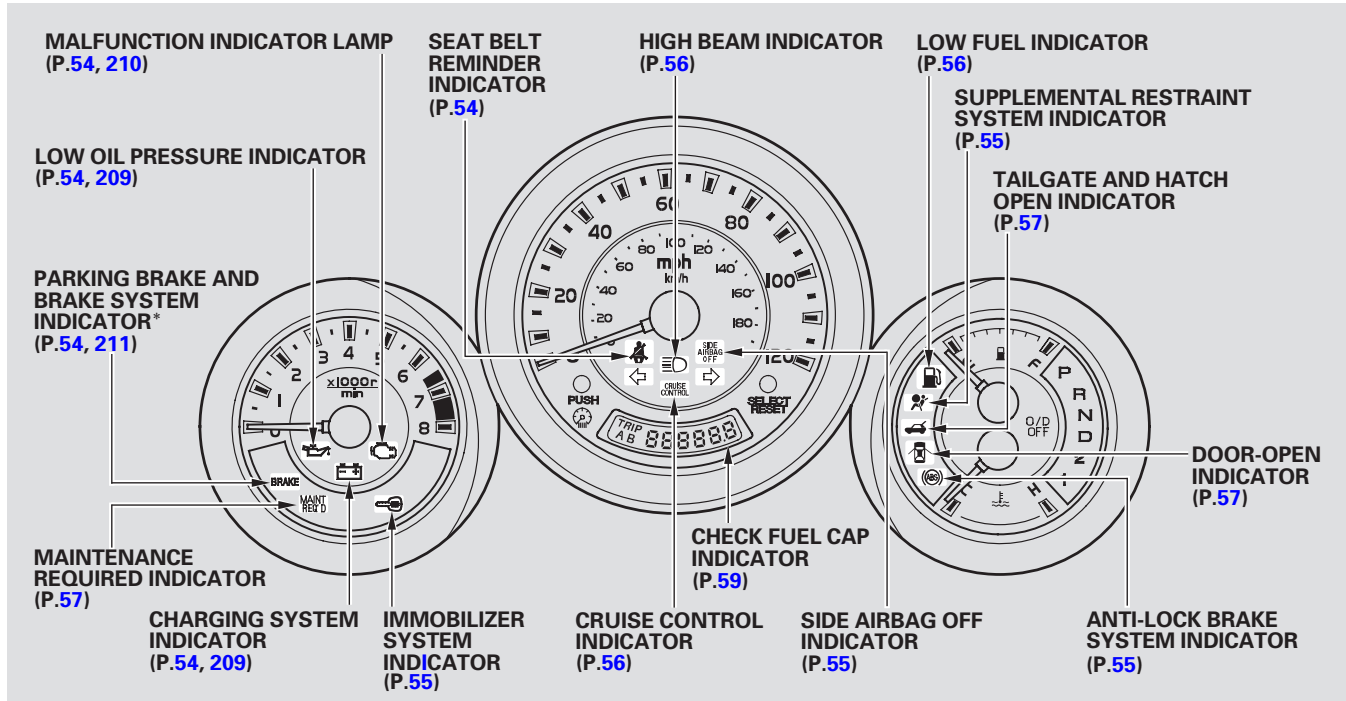

*The U.S. instrument panel is shown. Differences for the Canadian models are noted in the text.

Instrument Panel Indicators

The instrument panel has many indicators that give you important information about your vehicle.



Malfunction Indicator Lamp

See page [210](#).



Low Oil Pressure Indicator

The engine can be severely damaged if this indicator flashes or stays on when the engine is running. For more information, see page [209](#).



Charging System Indicator

If this indicator comes on when the engine is running, the battery is not being charged. For more information, see page [209](#).

U.S. Canada Parking Brake and Brake System Indicator

This indicator has two functions:

1. It comes on when you turn the ignition switch to the ON (II) position. It is a reminder to check the parking brake. Driving with the parking brake not fully released can damage the brakes and tires.
2. If it stays on after you have fully released the parking brake while the engine is running, or if it comes on while driving, there could be a problem with the brake system. For more information, see page [211](#).



Seat Belt Reminder Indicator

This indicator comes on when you turn the ignition switch to the ON (II) position. It reminds you and your passengers to fasten your seat belts. A beeper also sounds if you have not fastened your seat belt.

If you turn the ignition switch to the ON (II) position before fastening your seat belt, the beeper sounds and the indicator flashes. If you do not fasten your seat belt before the beeper stops, the indicator stops flashing but remains on.

If you continue driving without fastening your seat belt, the beeper sounds and the indicator flashes again at regular intervals.



Supplemental Restraint System Indicator

This indicator comes on when you turn the ignition switch to the ON (II) position. If it comes on at any other time, it indicates a potential problem with your front airbags or automatic seat belt tensioners. On models equipped with side airbags, this indicator will also alert you to a potential problem with your side airbags or passenger's side airbag automatic cutoff system. For complete information, see page 27.

Side Airbag Off Indicator



Standard on U.S. EX models and Canadian Y package

This indicator comes on when you turn the ignition switch to the ON (II) position. If it comes on at any other time, it indicates that the passenger's side airbag has automatically shut off. For more information, see page 28.



Anti-lock Brake System (ABS) Indicator

This indicator normally comes on for a few seconds when you turn the ignition switch to the ON (II) position, and when the ignition switch is turned to the START (III) position. If it comes on at any other time, there is a problem with the ABS. If this happens, have your vehicle checked at a dealer. With the indicator on, your vehicle still has

normal braking ability but no anti-lock brakes. For more information, see page 150.



Immobilizer System Indicator

This indicator comes on for a few seconds when you turn the ignition switch to the ON (II) position. It will then go off if you have inserted a properly-coded ignition key. If it is not a properly-coded key, the indicator will blink, and the engine will not start (see page 66).

This indicator also blinks several times when you turn the ignition switch from the ON (II) position to the ACCESSORY (I) or LOCK (0) position.

Instrument Panel Indicators



Turn Signal and Hazard Warning Indicators

The left or right turn signal indicator blinks when you signal a lane change or turn. If the indicators do not blink or they blink rapidly, it usually means one of the turn signal bulbs is burned out (see page [180](#)). Replace the bulb as soon as possible, since other drivers cannot see that you are signaling.

When you turn on the hazard warning button, both turn signal indicators blink. All turn signals on the outside of the vehicle should flash.

DRL

“Daytime Running Lights” Indicator

Canadian models only

This indicator comes on when you turn the ignition switch to the ON (II) position with the headlight switch off and the parking brake set. It should go off if you turn on the headlights or release the parking brake. If it comes on at any other time, it means there is a problem with the DRL. There may also be a problem with the high beam headlights.

CRUISE CONTROL

Cruise Control Indicator

If equipped

This indicator comes on when you set the cruise control. See page [120](#) for information on operating the cruise control.



High Beam Indicator

This indicator comes on with the high beam headlights. For more information, see page [62](#).

On Canadian models, this indicator comes on with reduced brightness when the daytime running lights (DRL) are on (see page [62](#)).



Low Fuel Indicator

This indicator comes on as a reminder that you must refuel soon.

When the indicator comes on, there is about 1.6 U.S. gal (6 ℓ) of fuel remaining in the tank before the needle reaches E. There is a small reserve of fuel remaining in the tank when the needle does reach E.



Washer Level Indicator

Canadian models only

This indicator comes on when the washer fluid level is low. Add washer fluid when you see this indicator come on (see page [174](#)).



Tailgate and Hatch Open Indicator

This indicator comes on if the tailgate or the hatch is not closed tightly.



Door-open Indicator

This indicator comes on if any door is not closed tightly.



Maintenance Required Indicator

This indicator reminds you that it is time to take your vehicle in for scheduled maintenance.

Refer to the maintenance schedules for normal and severe driving conditions on pages [165](#) – [166](#).

For the first 8,000 miles (12,800 km) after the maintenance required indicator is reset, it will come on for 2 seconds when you turn the ignition switch to the ON (II) position.

Between 8,000 miles (12,800 km) and 10,000 miles (16,000 km), this indicator will come on for 2 seconds when you first turn the ignition switch to the ON (II) position, and then flash for 10 seconds.

If you exceed 10,000 miles (16,000 km) without having the scheduled maintenance performed, this indicator will remain on as a constant reminder.

Your dealer will reset this indicator after completing the scheduled maintenance. If this maintenance is not done by your dealer, reset the indicator as follows.

1. Turn off the engine.
2. Press and hold the Select/Reset button on the instrument panel, then turn the ignition switch to the ON (II) position.
3. Hold the button for about 10 seconds until the indicator goes off.

Gauges

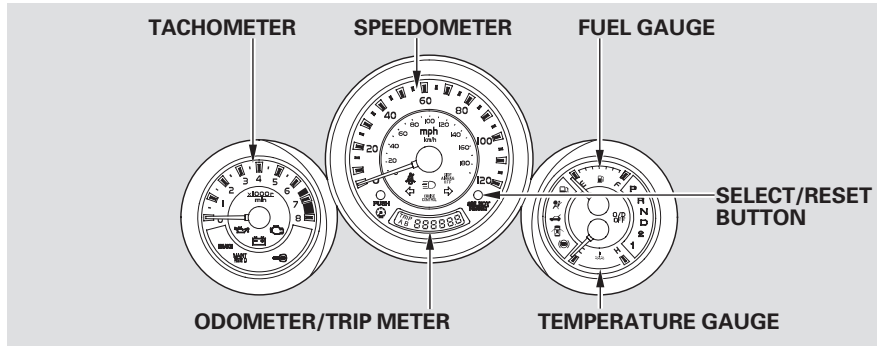

Trip Meter

This shows the number of miles (U.S.) or kilometers (Canada) driven since you last reset it.

There are two trip meters: Trip A and Trip B. Switch between these displays and the odometer by pressing the Select/Reset button repeatedly.

Each trip meter works independently, so you can keep track of two different distances.

To reset a trip meter, display it, and then press and hold the Select/Reset button until the number resets to "0.0." Both trip meters will reset if the vehicle's battery goes dead or is disconnected.

Odometer

The odometer shows the total distance your vehicle has been driven. It measures miles in U.S. models and kilometers in Canadian models. It is illegal under U.S. federal law and Canadian provincial regulations to disconnect, reset, or alter the odometer with the intent to change the number of miles or kilometers indicated.

Fuel Gauge

This shows how much fuel you have. It may show slightly more or less than the actual amount. Driving uphill or making turns can cause the needle to fluctuate or the low fuel indicator to come on early. The needle returns to the bottom after you turn off the ignition.

NOTICE

Avoid driving with an extremely low fuel level. Running out of fuel could cause the engine to misfire, damaging the catalytic converter.

Check Fuel Cap Indicator (odometer/trip meter message)

If your fuel cap is loose or missing, a “CHECK FUEL CAP” message appears as text in the odometer/trip meter display after you start the engine. Turn the engine off and confirm the fuel cap is installed. If it is, loosen the cap, then retighten it at least 3 clicks. When you restart the engine, the message appears again. To clear the message, press and hold the select/reset button until the message is replaced the odometer/trip meter display.

If the system still detects a loose or missing fuel cap, the malfunction indicator lamp (MIL) comes on. Turn the engine off, and check or retighten the fuel cap at least 3 clicks. The MIL goes out after several days of normal driving once the cap is tightened or replaced. If it does not go out, have your dealer inspect the vehicle. For more information, see page [210](#).

Temperature Gauge

This shows the temperature of the engine’s coolant. During normal operation, the pointer should rise to about the middle of the gauge. In severe driving conditions, the pointer may rise to the upper zone. If it reaches the red (hot) mark, pull safely to the side of the road. Turn to page [207](#) for instructions and precautions on checking the engine’s cooling system.

Controls Near the Steering Wheel

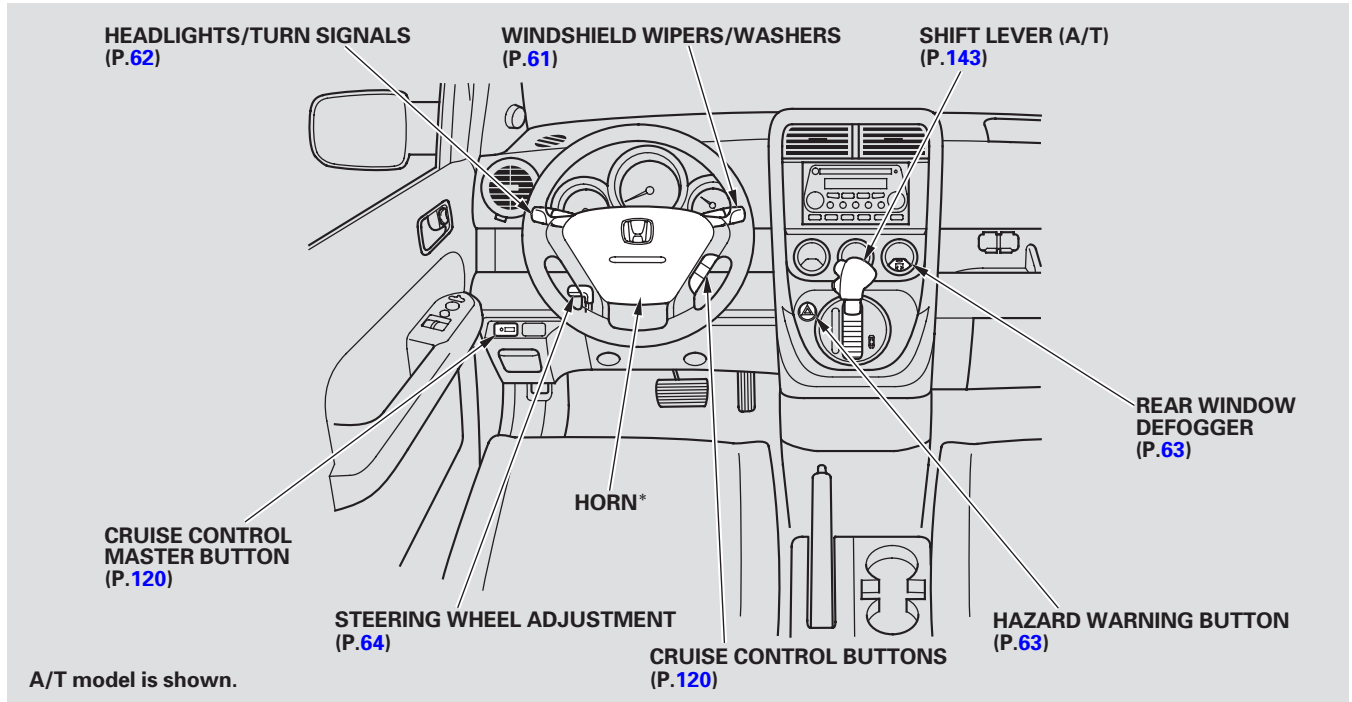

*: To use the horn, press the center pad of the steering wheel.

Windshield Wipers and Washers

Windshield Wiper

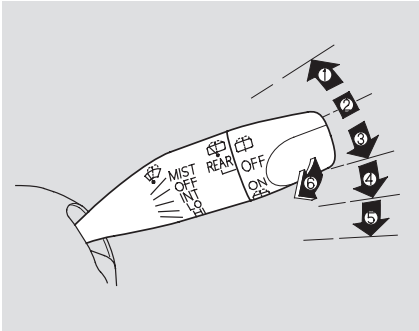

1. MIST
2. OFF
3. INT – Intermittent
4. LO – Low speed
5. HI – High speed
6. Windshield washers

Push the right lever up or down to select a position.

MIST – The wipers run at high speed until you release the lever.

OFF – The wipers are not activated.

INT – The wipers operate every few seconds.

LO – The wipers run at low speed.

HI – The wipers run at high speed.

Windshield Washer – Pull the wiper control lever toward you, and hold it. The washers spray until you release the lever. The wipers run at low speed, then complete one more sweep after you release the lever.

Rear Window Wiper and Washer

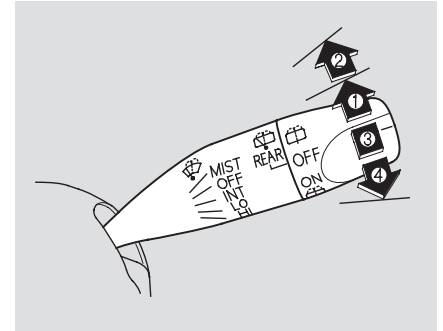

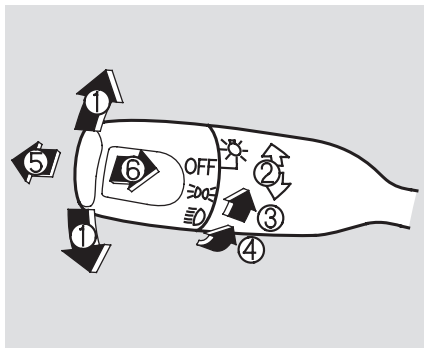

1. Rotate the switch clockwise to turn the rear window wiper ON.
2. Hold past ON to turn the window wiper on and the window washer on.
3. OFF
4. Rotate the switch counterclockwise to spray the window washer without activating the wiper.

Turn Signal and Headlights



1. Turn Signal
2. OFF
3. Parking and interior lights
4. Headlights on
5. High Beams
6. Flash high beams

Turn Signal — Push down on the lever to signal a left turn and up to signal a right turn. To signal a lane change, push lightly on the lever, and hold it. The lever will return to center when you release it or complete a turn.

Headlights — Turning switch to the  position turns on the parking lights, taillights, instrument panel lights, side-marker lights, and rear license plate lights. Turning the switch to the  position turns on the headlights. If you leave the lights on with the key removed from the ignition switch, you will hear a reminder tone when you open the driver's door.

High Beams — Push the lever back until you hear a click to turn on the high beams. The blue high beam indicator will come on (see page 56). Pull the lever back again to low beams.

To flash the high beams, pull the lever back lightly, then release it. The high beams will stay on as long as you hold the lever back.

Daytime Running Lights (Canadian Models)

With the headlight switch off, the high beam headlights come on with reduced brightness when you turn the ignition switch to the ON (II) position and release the parking brake. They remain on until you turn the ignition switch off, even if you set the parking brake.

The headlights revert to normal operation when you turn them on with the switch.

Instrument Panel Brightness, Hazard Warning Button, Rear Window Defogger

Instrument Panel Brightness

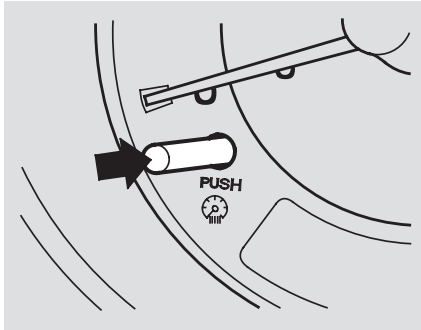

Push the button in the speedometer repeatedly to adjust the brightness of the instrument panel lights. There are six brightness levels. A segment display shows the current brightness level.

Hazard Warning Button

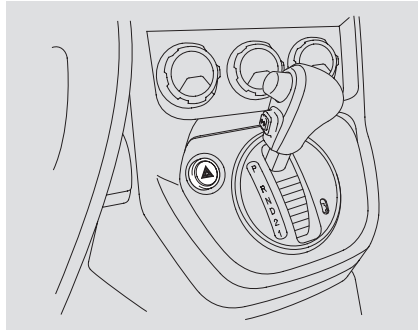

Push the button next to the shift lever to turn on the hazard warning lights (four-way flashers). This causes all four outside turn signals and both turn indicators in the instrument panel to flash. Use the hazard warning lights if you need to park in a dangerous area near heavy traffic, or if your vehicle is disabled.

Rear Window Defogger

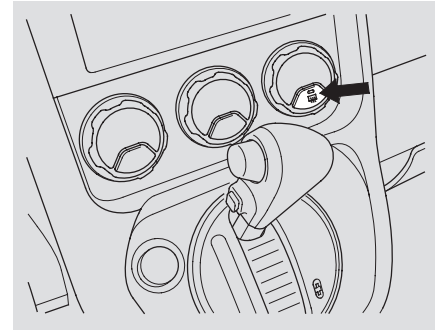

The rear window defogger will clear fog, frost, and thin ice from the window. Push the defogger button to turn it on and off. The indicator in the button comes on to show the defogger is on. If you do not turn it off, the defogger will shut itself off after about 15 minutes. It also shuts off when you turn off the ignition switch. You have to turn the defogger on again when you restart the vehicle. *CONTINUED*

Rear Window Defogger, Steering Wheel Adjustment

Make sure the rear window is clear and you have good visibility before starting to drive.

The defogger wires on the inside of the rear window can be accidentally damaged. When cleaning the glass, always wipe side-to-side.

Steering Wheel Adjustment

Make any steering wheel adjustment before you start driving.

⚠ WARNING

Adjusting the steering wheel position while driving may cause you to lose control of the vehicle and be seriously injured in a crash.

Adjust the steering wheel only when the vehicle is stopped.

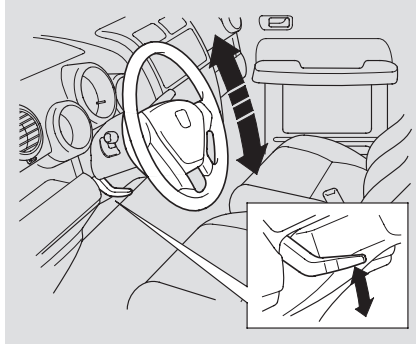

To adjust the steering wheel upward or downward:

1. Push the lever under the left side of the steering column all the way down.
2. Move the steering wheel up or down to the desired position. Make sure you can see the instrument panel gauges and the indicators.

3. Push the lever up to lock the steering wheel in that position.
4. Make sure you have securely locked the steering wheel in place by trying to move it up and down.

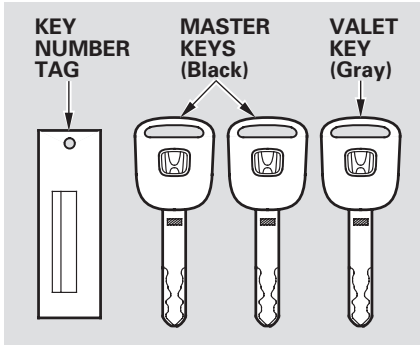

The master key fits all the locks on your vehicle. The valet key works only in the ignition and the door locks. You can keep the glove box and hatch locked when you leave your vehicle and the valet key at a parking facility.

You should have received a key number tag with your set of keys. You will need this key number if you ever have to get a key replaced. Use only Honda-approved key blanks.

These keys contain electronic circuits that are activated by the immobilizer system. They will not work to start the engine if the circuits are damaged.

- Protect the keys from direct sunlight, high temperature, and high humidity.
- Do not drop the keys or set heavy objects on them.
- Keep the keys away from liquids. If they get wet, dry them immediately with a soft cloth.

The keys do not contain batteries. Do not try to take them apart.

Some models also come with two remote transmitters; see page 67 for an explanation of their operation.

Immobilizer System

The immobilizer system protects your vehicle from theft. If an improperly-coded key (or other device) is used, the engine will not start.

When you turn the ignition switch to the ON (II) position, the immobilizer system indicator should come on for a few seconds, then go off. If the indicator starts to blink, it means the system does not recognize the coding of the key. Turn the ignition switch to the LOCK (0) position, remove the key, reinsert it, and turn the ignition switch to the ON (II) position again.

The system may not recognize your key's coding if another immobilizer key or other metal object (i.e. key fob) is near the ignition switch when you insert the key.

If the system repeatedly does not recognize the coding of your key, contact your dealer.

Do not attempt to alter this system or add other devices to it. Electrical problems could result that may make your vehicle undrivable.

If you have lost your key and cannot start your engine, contact your dealer.

*As required by the FCC:
This device complies with Part 15 of the FCC rules. Operation is subject to the following two conditions: (1) This device may not cause harmful interference, and (2) this device must accept any interference received, including interference that may cause undesired operation.*

Changes or modifications not expressly approved by the party responsible for compliance could void the user's authority to operate the equipment.

*This device complies with Industry Canada Standard RSS-210.
Operation is subject to the following two conditions: (1) this device may not cause interference, and (2) this device must accept any interference that may cause undesired operation of the device.*

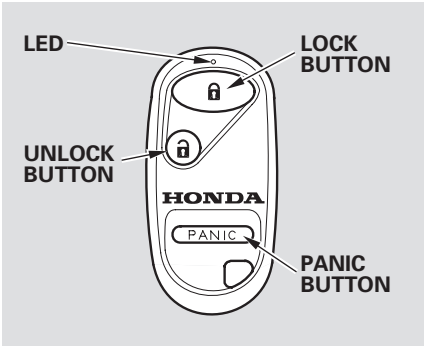

On EX models

LOCK – Press this button once to lock both doors and hatch. Some exterior lights will flash. When you push LOCK twice within 5 seconds, you will hear a beep to verify that the doors are locked. You cannot lock it if any door is not fully closed or key is in the ignition switch.

UNLOCK – Press this button once to unlock the driver’s door. Push it twice to unlock the passenger’s door and the hatch. Some exterior lights will flash twice each time you press the button. If you do not open either door or the hatch within 30 seconds, they will automatically relock.

PANIC – Press this button for about 1 second to attract attention; the horn will sound and the exterior lights will flash for about 30 seconds. To cancel panic mode, press any other button on the remote transmitter, or turn the ignition switch to the ON (II) position.

Remote Transmitter Care

- Avoid dropping or throwing the transmitter.
- Protect the transmitter from extreme temperature.
- Do not immerse the transmitter in any liquid.
- If you lose a transmitter, the replacement needs to be reprogrammed by your dealer.

Remote Transmitter

Replacing the Transmitter Battery

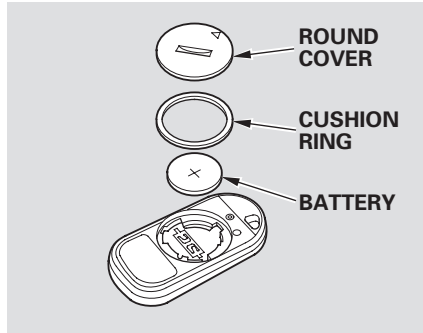

If it takes several pushes on the button to lock or unlock the doors and the hatch, replace the battery as soon as possible.

Battery type: CR2025

To replace the battery, remove the round cover on the back of the transmitter by turning it counterclockwise with a coin. Insert a new battery with the + side facing up, and reinstall the cushion ring. Align the ▽ mark on the cover with the ⊙ mark on the transmitter. Set the cover in place and turn it clockwise.

As required by the FCC:

This device complies with Part 15 of the FCC rules. Operation is subject to the following two conditions: (1) This device may not cause harmful interference, and (2) this device must accept any interference received, including interference that may cause undesired operation.

Changes or modifications not expressly approved by the party responsible for compliance could void the user's authority to operate the equipment.

This device complies with Industry Canada Standard RSS-210. Operation is subject to the following two conditions: (1) this device may not cause interference, and (2) this device must accept any interference that may cause undesired operation of the device.

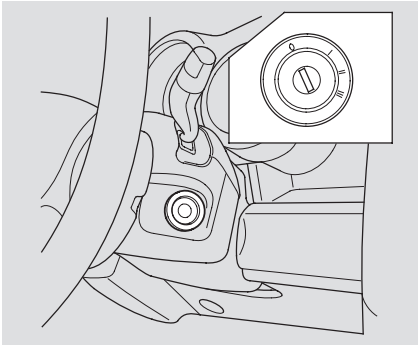

The ignition switch has four positions: LOCK (0), ACCESSORY (I), ON (II), and START (III).

LOCK (0) – You can insert or remove the key only in this position. To turn the key, push it in slightly. If your vehicle has an automatic transmission, the shift lever must also be in park.

If the front wheels are turned, the anti-theft lock may make it difficult to turn the key. Firmly turn the steering wheel to the left or right as you turn the key.

ACCESSORY (I) – You can operate the audio system and the accessory power sockets in this position.

ON (II) – This is the normal key position when driving. Several of the indicators on the instrument panel come on as a test when you turn the ignition switch from the ACCESSORY (I) to the ON (II) position.

START (III) – Use this position only to start the engine. The switch returns to the ON (II) position when you let go of the key.

You will hear a reminder beeper if you leave the key in the ignition switch in the LOCK (0) or the ACCESSORY (I) position and open the driver's door. Remove the key to turn off the beeper.

If your vehicle has an automatic transmission, the shift lever must be in Park before you can remove the key from the ignition switch.

⚠ WARNING

Removing the key from the ignition switch while driving locks the steering. This can cause you to lose control of the vehicle.

Remove the key from the ignition switch only when parked.

Door Locks

Power Door Locks

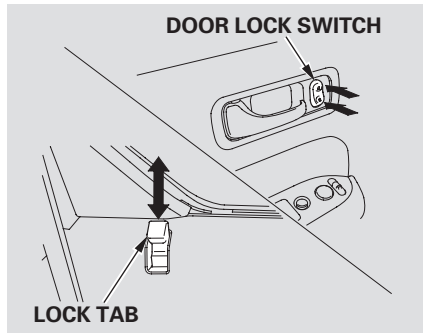

To lock all of the doors and hatch, press the door lock switch on either front door, or press the lock tab down on the driver's door, or use the key on the outside lock.

Pressing up on the door lock switch will unlock all of the doors and the hatch.

The lock tab on the passenger's door locks and unlocks only that door. Pulling up on the driver's door lock tab only unlocks the driver's door.

To lock the driver's door, remove the key from the ignition switch, pull the outside door handle and push the lock tab down or push the door lock switch down. Release the handle, then close the door.

To unlock the driver's door from the outside, turn the key and release it.

Rear Doors

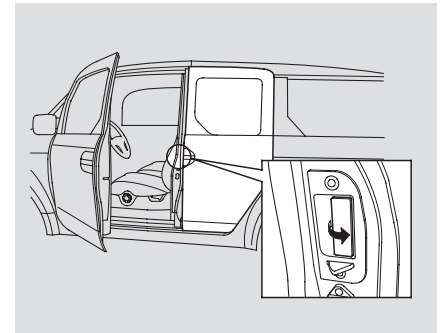

To open the rear door, pull the rear door handle located in the rear door edge. The rear door can be opened only when the front door is open.

To close the doors, close the rear door first, then the front door. The front door cannot be latched without first closing the rear door. Closing the rear door on the front door will damage both doors.

Hatch

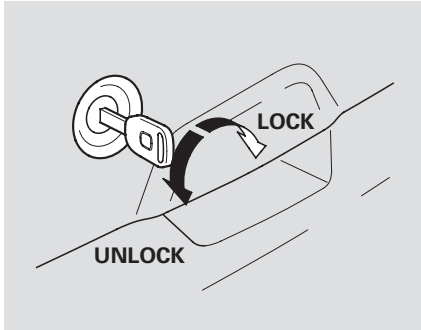

To lock or unlock the hatch.

- Use your master key to lock and unlock the hatch. Turn the key clockwise to lock the hatch, and counterclockwise to unlock it.

- Lock the hatch by pushing down the lock tab on the driver's door (see page 70), or by using the master key in the driver's door lock.
- Lock or unlock the hatch with the master door lock switch.

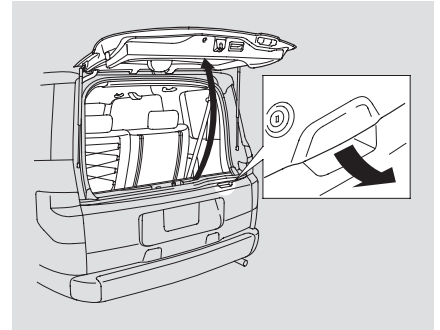

With the hatch unlocked, open it by pulling the handle and lifting up. To close the hatch, lower it, then press down on the back edge.

When both the hatch and tailgate are open, the hatch cannot be latched without first closing the tailgate.

Door Locks

Tailgate

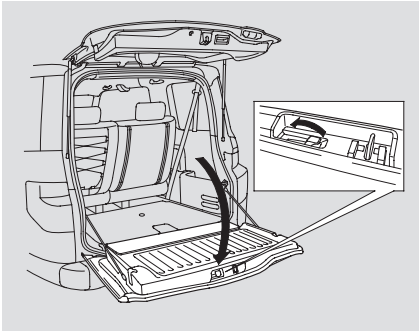

You can open the tailgate only when the hatch is open. To open the tailgate, slide the lock lever to the left and swing down the tailgate. To close the tailgate, lift it up and push it firmly until it latches.

Before closing the tailgate, make sure the hatch is raised. Closing the tailgate on the lowered hatch can damage the hatch and the tailgate.

See page [132](#) for information on cargo loading. Keep the tailgate and the hatch closed at all times while driving to avoid damaging them, and to prevent exhaust gas from getting into the interior. See **Carbon Monoxide Hazard** on page [47](#).

Seat Adjustments

See pages 12 – 14 for important safety information and warnings about how to properly position seats and seat-backs.

Make all seat adjustments before you start driving.

Front Seat

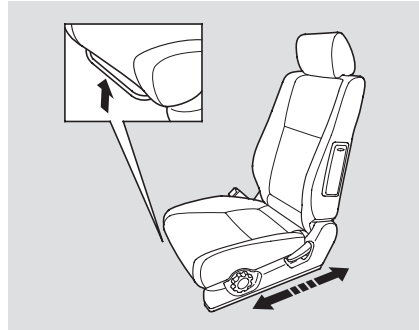

To adjust the seat forward and backward, pull up on the bar under the seat cushion's front edge. Try to move the seat to make sure it is locked in position.

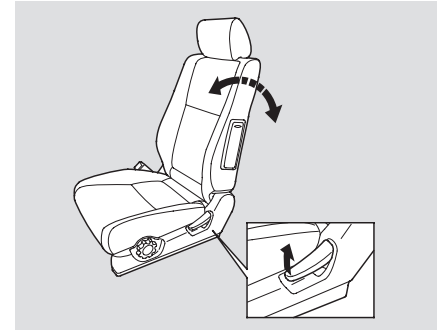

To change the seat-back angle of the front seat, pull up on the lever on the outside of the seat bottom. Adjust the seat-back and make sure it locks into position.

Seats

Driver's Seat Height Adjustment

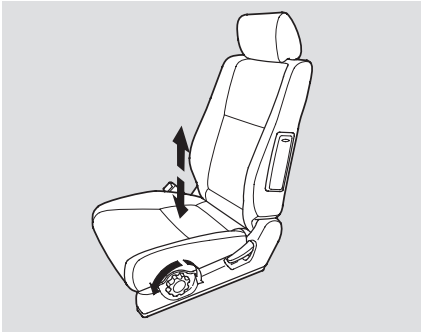

To adjust the height of the driver's seat, turn the dial on the outside of the seat bottom.

Front Seat Armrests



On EX models
Each front seat has an armrest on the side of the seat-back. To use it, pivot it down.

Rear Seat

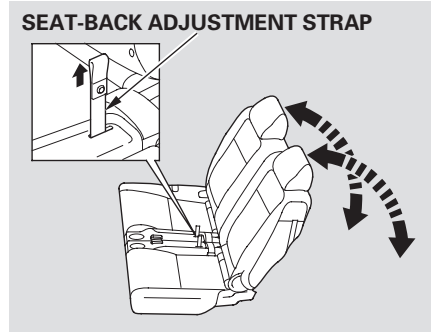

To change the angle of the rear seat-back, pull the strap at the inside edge of the seat cushion, make sure the seat-back locks into position.

Head Restraints

See page 15 for important safety information and a warning about how to properly position the head restraints.

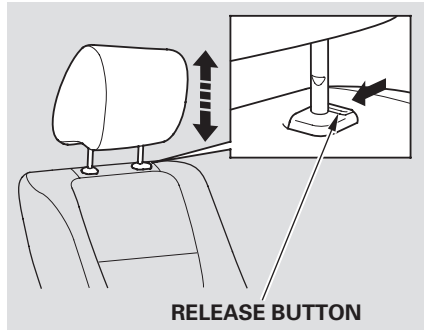

Your vehicle is equipped with head restraints in all seating positions to help protect you and your passengers from whiplash and other injuries.

They are most effective when you adjust them so the back of the occupant’s head rests against the center of the restraint.

The head restraints in the front and rear seating positions adjust for height. You need both hands to adjust the restraint. To raise it, pull upward. To lower the restraint, push the release button sideways and push the restraint down.

Rear Seat Access

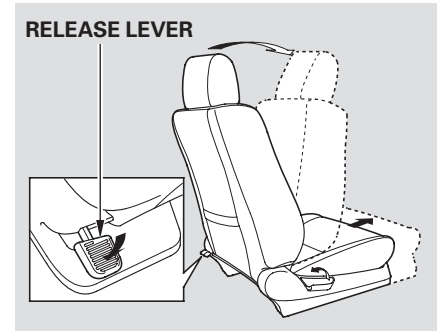

The rear seat passengers can get out through the passenger’s door. Push down on the release lever at the base of the front passenger’s seat-back, and push the seat-back forward. The seat-back will tilt forward and the entire seat will move forward.

Make sure the seat is upright and fully latched before sitting in it.

Seats

Reclining the Front Seats

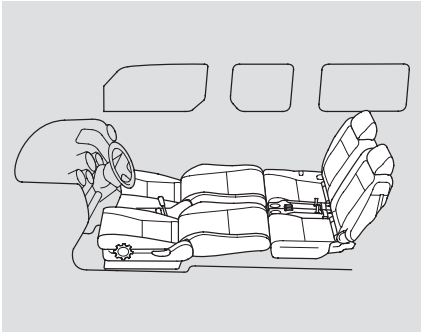

You can recline the seat-backs on the front seats so they are level with the rear seat cushions, making a large cushioned area. To do this:

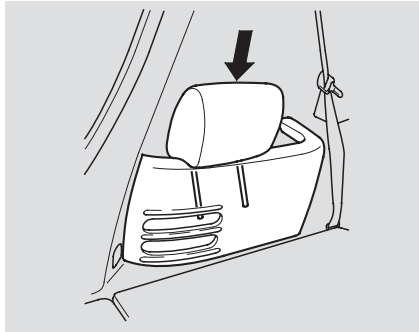

1. Remove the head restraints from the front seats (see page 75), and store them in the side pockets of the cargo area.

2. Adjust the front seats forward as far as they will go. Pull up the seat-back angle adjustment lever and pivot the seat-back backward until it is level with the rear seat cushion.
3. Move the front seat backward until it touches the rear seat.
4. Adjust the rear seat-back to the desired position.

Reverse this procedure to return the front and rear seats to the upright position. Make sure you install the head restraints and the seats are locked securely before driving.

When you return the seat-back to the upright position, hold the seat-back to keep it from going up too quickly.

Folding the Rear Seats

To create more cargo space, you can fold up each rear seat to each side wall separately.

1. Lower the head restraint to its lowest position.

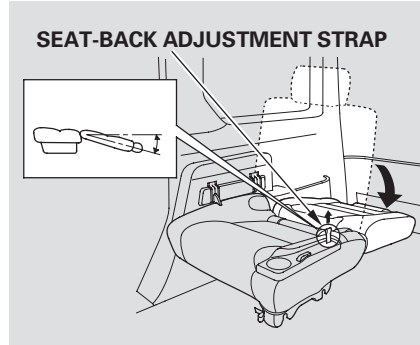

2. Pull the seat-back adjustment strap at the inside edge of the seat cushion and push the seat-back backward as far as it will go.



3. Pull the release strap on the seat support, and pivot the seat toward the vehicle's side wall.

CONTINUED

Seats

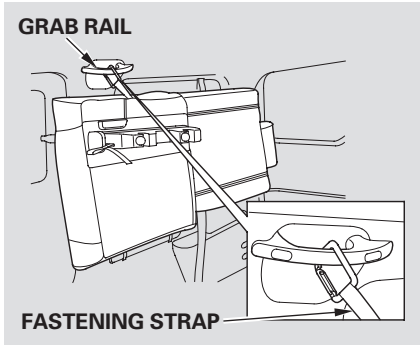

4. A fastening strap is attached to the inside of the seat cushion. While pushing the seat up and toward the side wall, hook the fastening strap to the grab rail.

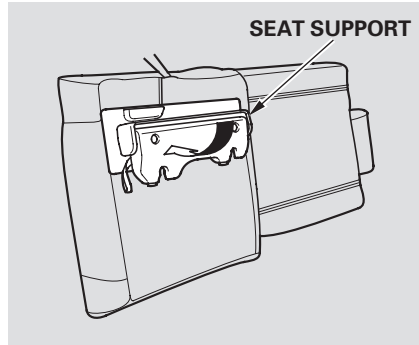

5. Fold down the seat support.

Reverse this procedure to return the rear seat to the upright position. When not in use, store the fastening strap hook in the fabric pocket on the bottom of the seat cushion. Make sure the seat is locked securely.

Removing the Rear Seats



Both seats can be removed to give more cargo capacity. To remove a seat:

1. Pull the release strap on the seat support to unlock the seat support.

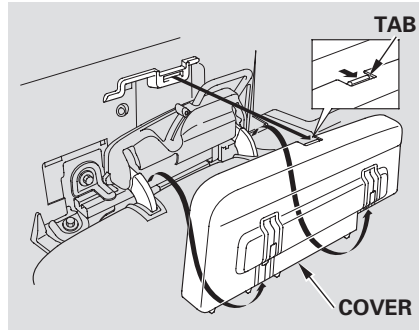

2. Remove the cover between the seat cushion and the side wall by pulling the tab and pulling the cover straight up.

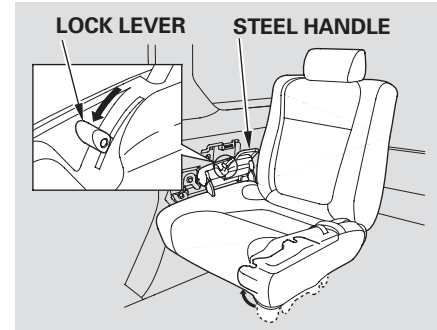

3. Push the lock lever forward to unlock the seat.

CONTINUED

Seats

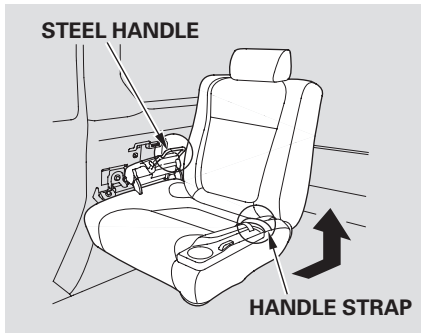

4. Hold the steel handle next to the lock lever and the handle strap at the outside edge of the seat cushion, and remove the entire seat by pulling it up and backward.

Reverse this procedure to reinstall the seat. Make sure the seat is securely locked.

Always remove an unsecured seat from the vehicle before driving. A seat that is not locked in place could be thrown about and cause injury in a sudden stop or crash.

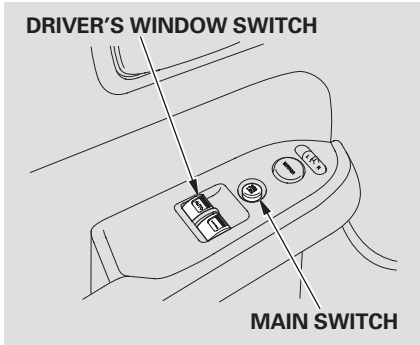

Turn the ignition switch to the ON (II) position to raise or lower either window. To open the window, push the switch down and hold it. Release the switch when you want the window to stop. Pull back on the switch and hold it to close the window.

⚠ WARNING

Closing a power window on someone's hands or fingers can cause serious injury.

Make sure your passenger is away from the window before closing it.

AUTO – To open/close the driver's window, push the window switch firmly down or up to the second detent, and release it. The window will automatically go up or down all the way. To stop the window, pull/push on the window switch briefly.

If the MAIN switch is OFF, the passenger's window cannot be raised or lowered. Keep the MAIN switch off when you have children in the vehicle so they do not injure themselves by operating the passenger's window unintentionally.

AUTO REVERSE – If the driver's window senses any obstacle while it is closing automatically, it will reverse direction, and then stop. To close the window, remove the obstacle, then use the window switch again.

If your vehicle's battery is disconnected or goes dead, or the driver's window fuse is removed, the AUTO function will be disabled. The power window system needs to be reset after reconnecting the battery or installing the fuse.

1. Start the engine. Push down and hold the driver's window switch until the window is fully open.
2. Pull and hold the driver's window switch to close the window completely, then hold the switch for about 2 seconds.

If the power windows do not operate properly after resetting, have your vehicle checked by your dealer.

Mirrors

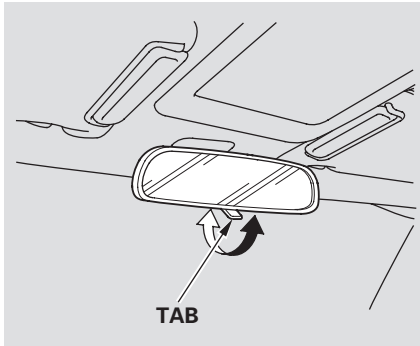

Keep the inside and outside mirrors clean and adjusted for best visibility. Be sure to adjust the mirrors before you start driving.

The inside mirror has day and night positions. The night position reduces glare from headlights behind you. Flip the tab on the bottom edge of the mirror to select the day or night position.

Adjusting the Power Mirrors

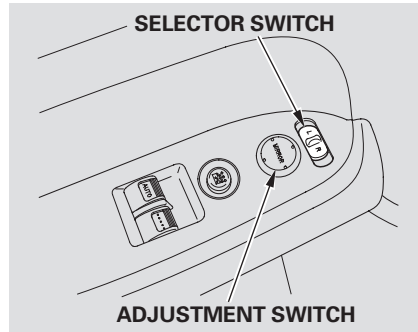

1. Move the selector switch to L (driver's side) or R (passenger's side).

2. Push the appropriate edge of the adjustment switch to move the mirror right, left, up, or down.
3. When you finish, move the selector switch to the center (off) position. This turns the adjustment switch off to keep your settings.

Rear Windows, Parking Brake, Skylight

Rear Windows

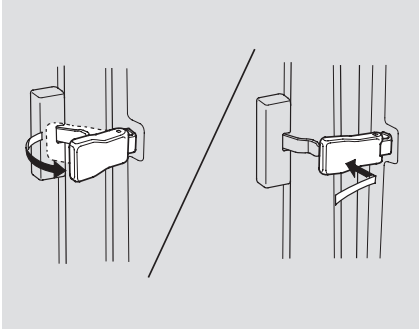

To open a rear window, pull the lever towards you, then push it out until it locks. To close the rear window pull the lever towards you, then push it back. Make sure the window is fully closed and locked.

Parking Brake

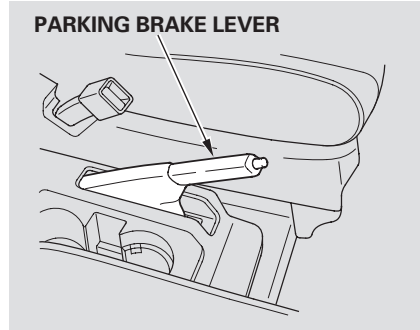

To apply the parking brake, pull the lever up fully. To release it, pull up slightly, push the button, and lower the lever. The parking brake indicator on the instrument panel should go out when the parking brake is fully released (see page 54).

NOTICE

Driving the vehicle with the parking brake applied can damage the rear brakes and axles.

Skylight

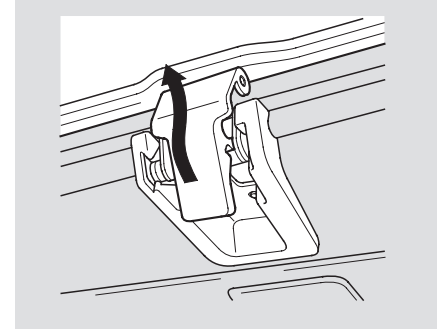

If equipped

To lift up the rear of the skylight for ventilation, pull down the lever to unlock the skylight, then push it up until the skylight is locked in the tilt-up position.

To close the skylight, pull down the lever to unlock the skylight, then push it back in place. Make sure the skylight is fully closed and locked.

CONTINUED

Skylight

NOTICE

If you try to tilt up the skylight in below-freezing temperatures, or when it is covered with snow or ice, you can damage it.

Before lifting the skylight, make sure the roof of the vehicle is dry. Rain or remaining water after car-washing may get into the frame of the skylight. In winter, remove the buildup of snow on the roof.

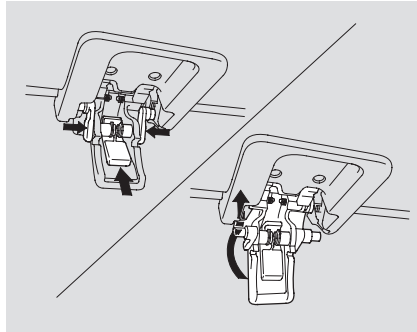

To remove the skylight: Turn off the engine, and set the parking brake. Then pull down the lever, squeeze both sides of the pivot while pushing up the red tab in the lever, and pull the lever assembly away from the ceiling.

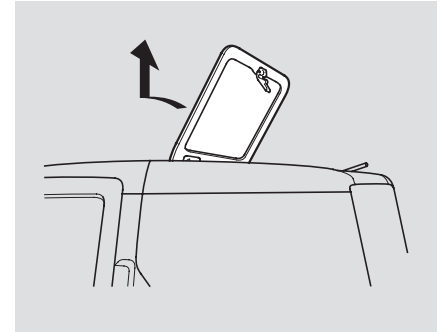

Push up the rear of the skylight. Standing on the tailgate with the hatch down, hold both sides of the skylight and pull it toward you to remove it from the vehicle roof.

NOTICE

The maximum weight on the tailgate is 440 lbs (200 kg).

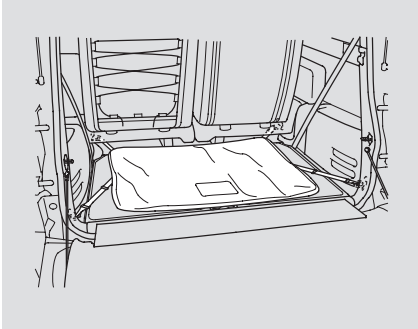

With the rear seats in their upright position, store the skylight, face down in its bag in the cargo area. Secure the bag with four hooks on the cargo area floor. Do not store anything on top of the skylight.

⚠ WARNING

An unsecured skylight can be thrown about and cause serious injury in a sudden stop or crash.

Make sure to store the skylight in its bag, and secure the bag to the hooks on the cargo area floor.

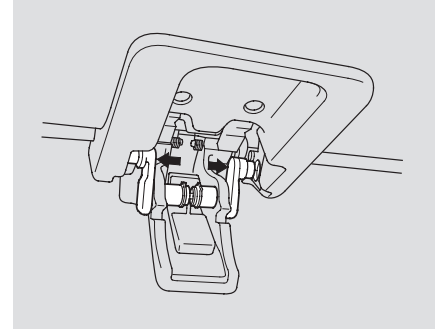

To reinstall the skylight, make sure the air deflector is pushed down. When reinstalling the lever assembly, push in both red pivots, and align with the receptacle holes. Let the pivots move out until they rest in the holes securely. Make sure the skylight is fully closed and latched.

Interior Convenience Items

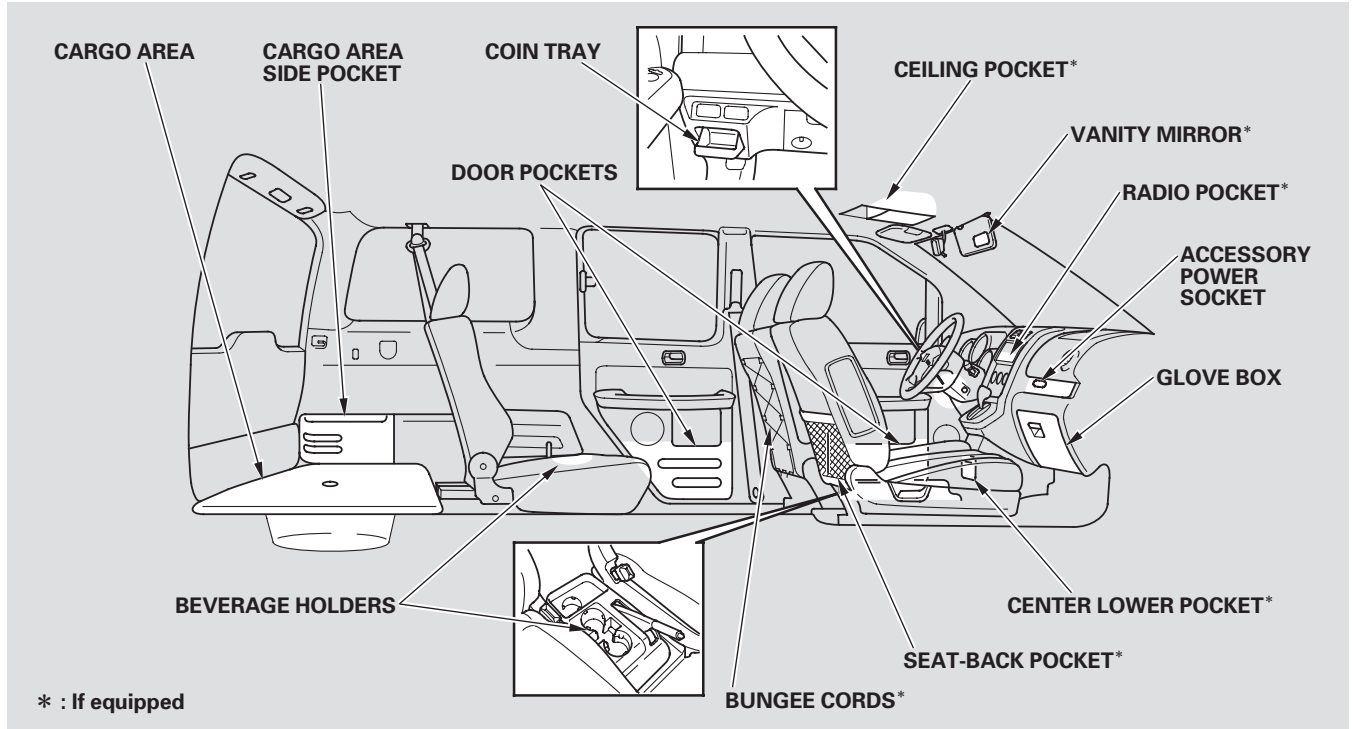

Beverage Holders

Be careful when you are using the beverage holders. A spilled liquid that is very hot can scald you or your passengers. Spilled liquids can also damage the upholstery, and electrical components in the interior.

Accessory Power Sockets

Your vehicle has one or two accessory power sockets, depending on the model. All models have a front accessory power socket on the dashboard above the glove box.

The EX model has another accessory power socket in the cargo area on the passenger's side.

These sockets are intended to supply power for 12 volt DC accessories that are rated 120 watts or less (10 amps).

None of the sockets will power an automotive type cigarette lighter element. When more than one socket is being used, the combined power rating of the accessories should be 120 watts or less (10 amps).

Glove Box

Open the glove box by pulling the bottom of the handle. Close it with a firm push. Lock or unlock the glove box with the master key.

WARNING

An open glove box can cause serious injury to your passenger in a crash, even if the passenger is wearing the seat belt.

Always keep the glove box closed while driving.

Interior Lights

Ceiling Light

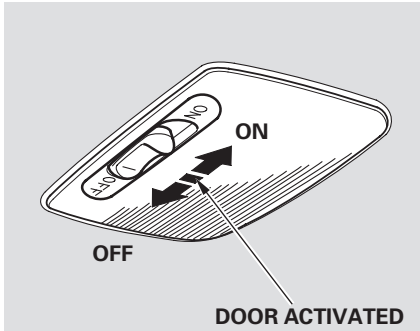

The ceiling light has a three-position switch: ON, Door Activated, and OFF.

In the Door Activated (center) position, the light comes on when you:

- Open any door.
- Remove the key from the ignition.
If you do not open a door, the light fades out in about 30 seconds.
- Unlock the doors with the key or remote transmitter.

Cargo Area Light

The cargo area light has a three-position switch. In the center position, the light comes on when you open the hatch.

Spotlights

On U.S. EX models and Canadian Y package

Turn on the spotlight by pushing the lens. Push the lens again to turn it off. You can use the spotlights at all times.

Ignition Switch Light

The ignition switch light comes on when you unlock the driver's door, and fades out about 30 seconds after you close the door.

The heating and air conditioning system in your vehicle provides a comfortable driving environment in all weather conditions.

The standard audio system has many features. This section describes those features and how to use them. (If you have an optional audio system, refer to the operating instructions that came with it.)

Your vehicle has an anti-theft audio system that requires a code number to enable it.

Vents, Heating, and A/C	90
Air Flow Controls	91
Ventilation	92
Using the Heater	92
Using the A/C	92
Dehumidify the Interior.....	93
To Defog and Defrost	93
To Remove Exterior Frost or Ice From the Windows.....	93
Playing the AM/FM Radio.....	94
AM/FM Radio Reception.....	98
Playing the XM® Satellite Radio	100
Playing a Disc.....	106
Protecting Your Discs.....	113
Disc Player Error Messages	114
Disc Changer Error Messages	115
Radio Theft Protection.....	116
Setting the Clock	117
Remote Audio Controls.....	119
Cruise Control.....	120

Vents, Heating, and A/C

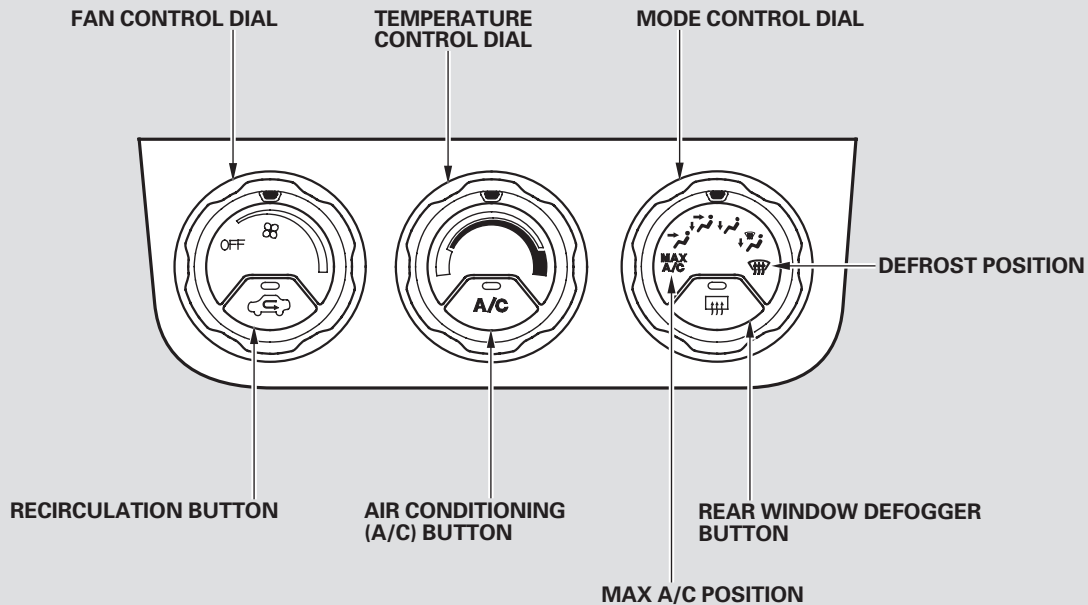

Air Flow Controls

Fan Control Dial

Turn this dial clockwise to increase the fan speed and airflow.

Temperature Control Dial

Turning this dial clockwise increases the temperature of the airflow.

Air Conditioning (A/C) Button

This button turns the air conditioning on and off. The indicator in the button is on when the A/C is on.

Recirculation Button

When the recirculation indicator is on, air from the vehicle's interior is sent throughout the system again. When the indicator is off, air is brought in from the outside of the vehicle (fresh air mode).

The outside air intakes for the heating and cooling system are at the base of the windshield. Keep this area clear of leaves and other debris.

The system should be left in fresh air mode under almost all conditions. Keeping the system in recirculation mode, particularly with the A/C off, can cause the windows to fog up.

Switch to recirculation mode when driving through dusty or smoky conditions, then return to fresh air mode.

Rear Window Defogger Button

This button turns the rear window defogger off and on (see page 63).

Mode Control Dial

Use the mode control dial to select the vents the air flows from. Some air will flow from the dashboard vents in all modes.

MAX A/C

The system automatically turns on the A/C and switches to recirculation mode. Air flows from the center and side vents in the dashboard.



Air flows from the center and corner vents in the dashboard.



Airflow is divided between the vents in the dashboard and the floor vents.



Air flows from the floor vents. When you select , the system automatically switches to fresh air mode.





Airflow is divided between the floor vents and the defroster vents at the base of the windshield.

CONTINUED

Vents, Heating, and A/C

 Air flows from the defroster vents at the base of the windshield.

When you select  or  , the system automatically switches to fresh air mode and turns on the A/C. The A/C indicator does not come on.

Ventilation (fresh air mode)

The flow-through ventilation system draws in outside air, circulates it through the interior, then exhausts it through vents near the tailgate.

1. Turn the temperature control dial all the way to the left.
2. Make sure the A/C is off.
3. Select  and fresh air mode.
4. Set the fan to the desired speed.

Using the Heater

The heater uses engine coolant to warm the air. If the engine is cold, it will be several minutes before you feel warm air coming from the system.

1. Select  and fresh air mode.
2. Set the fan to the desired speed.
3. Adjust the warmth of the air with the temperature control dial.

Using the A/C

Air conditioning places an extra load on the engine. Watch the engine coolant temperature gauge (see page 59). If it moves near the red zone, turn off the A/C until the gauge reading returns to normal.

1. Turn on the A/C by pressing the button. The indicator in the button comes on when a fan speed is selected.
2. Make sure the temperature control dial is all the way to the left.
3. Select  .
4. If the outside air is humid, select recirculation mode. If the outside air is dry, select fresh air mode.
5. Set the fan to the desired speed.
If the interior is very warm, you can cool it down more rapidly by partially opening the windows, turning on the A/C, and setting the fan to maximum speed in Fresh Air mode.

To cool the interior with MAX A/C:

1. Set the mode control dial to MAX A/C.
The system automatically turns on the A/C, selects  and switches to recirculation mode.
2. Make sure the temperature control dial is all the way to the left.
3. Set the fan to the desired speed.

Dehumidify the Interior



Air conditioning, as it cools, removes moisture from the air. When used in combination with the heater, it makes the interior warm and dry.

1. Switch the fan on.
2. Turn on the air conditioning.
3. Select  and fresh air mode.
4. Adjust the temperature control dial to your preference.

This setting is suitable for all driving conditions whenever the outside temperature is above 32°F (0°C).



To Defog and Defrost

To remove fog from the inside of the windows:

1. Set the fan to the desired speed, or high for faster defrosting.
2. Select . The system automatically switches to fresh air mode and turns on the A/C. (The A/C indicator will not come on in U.S. vehicles, if the A/C was off to start with)
3. Adjust the temperature control dial so the airflow feels warm.
4. Select  to help clear the rear window.
5. To increase airflow to the windshield, close the corner vents.

When you switch to another mode from , the A/C turns off. But if it was on to start with, it stays on.

To Remove Exterior Frost or Ice From the Windows

1. Select . The system automatically switches to fresh air mode and turns on the A/C. The A/C indicator does not come on in U.S. vehicle, if the A/C was off to start with.
2. Select .
3. Set the fan and temperature controls to maximum level.
4. Select  to help clear the rear window.

To clear the windows faster, you can close the dashboard corner vents by rotating the wheel below each vent. This sends more warm air to the windshield defroster vents. Once the windshield is clear, select fresh air mode to avoid fogging the windows.

For your safety, make sure you have a clear view through all the windows before driving.

Playing the AM/FM Radio

U.S. LX and Canadian Base models

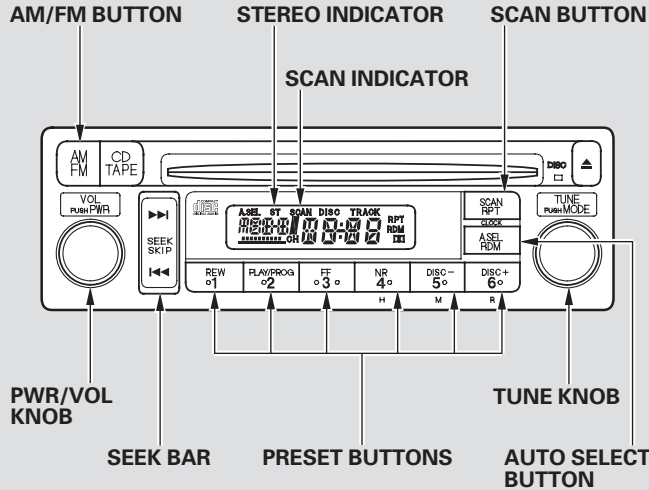

Canadian Y package

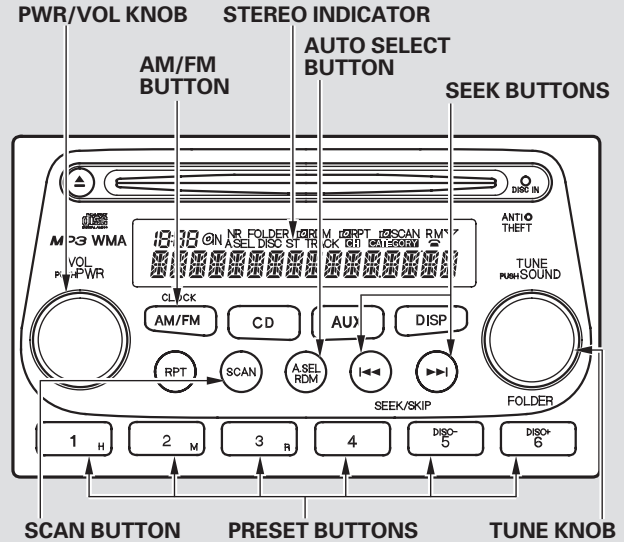

Playing the AM/FM Radio

U.S. EX models

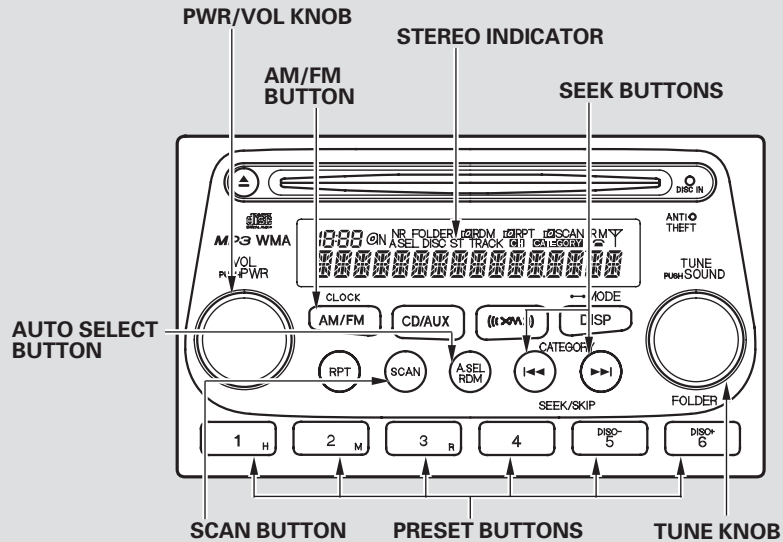

Features

Playing the AM/FM Radio

To Play the Radio

The ignition switch must be in the ACCESSORY (I) or the ON (II) position. Turn the system on by pushing the PWR/VOL knob or the AM/FM button. Adjust the volume by turning the same knob.

The band and frequency that the radio was last tuned to is displayed. To change bands, press the FM/AM button. On the FM band, ST will be displayed if the station is broadcasting in stereo. Stereo reproduction on AM is not available.

To Select a Station

You can use any of five methods to find radio stations on the selected band: **TUNE**, **SEEK**, **SCAN**, the preset buttons, and **AUTO SELECT**.

TUNE — Use the TUNE knob to tune the radio to a desired frequency. Turn the knob right to tune to a higher frequency, or left to tune to a

lower frequency.

SEEK — The seek function searches up and down from the current frequency to find a station with a strong signal. To activate it, press either (◀◀ or ▶▶), then release it.

SCAN — The scan function samples all stations with strong signals on the selected band. To activate it, press the SCAN button, then release it. You will see SCAN in the display. The system will scan for a station with a strong signal. When it finds one, it will stop and play that station for about 5 seconds (U.S. LX and Canadian base models) or 10 seconds (U.S. EX and Canadian Y package models).

If you do nothing, the system will then scan for the next strong station and play it for 5 seconds (U.S. LX and Canadian base models) or 10

seconds (U.S. EX and Canadian Y package models). When it plays a station you want to listen to, press the SCAN button again.

Preset — Each preset button can store one frequency on AM and two frequencies on FM.

1. Select the desired band, AM or FM. FM1 and FM2 let you store two frequencies with each preset button.
2. Use the tune, seek, or scan function to tune the radio to a desired station.
3. Pick a preset button, and hold it until you hear a beep.
4. Repeat steps 1 through 3 to store a total of six stations on AM and twelve stations on FM.

AUTO SELECT – If you are traveling far from home and can no longer receive your preset stations, you can use the auto select feature to find stations in the local area.

Press the A. SEL button. “A. SEL” flashes in the display, and the system goes into scan mode for several seconds. It stores the frequencies of six AM and twelve FM stations in the preset buttons.

You will see a “0” displayed after pressing a preset button if auto select cannot find a strong station for every preset button.

If you do not like the stations auto select has stored, you can store other frequencies on the preset buttons as previously described.

To turn off auto select, press the A. SEL button. This restores the presets you originally set.

Adjusting the Sound

Press the MODE or SOUND knob repeatedly to display the bass (BAS), treble (TRE), balance (BAL), fader (FAD), and sub-woofer (SUB-W) settings.

Each mode is shown in the display as it changes. Turn the MODE or SOUND knob to adjust the setting to your liking. When the level reaches the center, you will see “C” in the display. The system will automatically return the display to the selected audio mode about 5 seconds after you stop adjusting a mode.

Balance/Fader – These two modes adjust the strength of the sound coming from each speaker. BAL adjusts the side-to-side strength, while FAD adjusts the front-to-back strength.

Treble/Bass/Sub-Woofers – Use the TRE/BAS/SUB-W modes to adjust the tone to your liking.

AM/FM Radio Reception

Radio Frequencies

The radio can receive the complete AM and FM bands.

Those bands cover these frequencies:

AM band: 530 to 1,710 kHz

FM band: 87.7 to 107.9 MHz

Radio stations on the AM band are assigned frequencies at least 10 kHz apart (530, 540, 550). Stations on the FM band are assigned frequencies at least 0.2 MHz apart (87.9, 88.1, 88.3).

Stations must use these exact frequencies. It is fairly common for stations to round-off the frequency in their advertising, so your radio could display a frequency of 100.9 even though the announcer may identify the station as “FM101.”

Radio Reception

How well the radio receives stations is dependent on many factors, such as the distance from the station’s transmitter, nearby large objects, and atmospheric conditions.

A radio station’s signal gets weaker as you get farther away from its transmitter. If you are listening to an AM station, you will notice the sound volume becoming weaker, and the station drifting in and out. If you are listening to an FM station, you will see the stereo indicator flickering off and on as the signal weakens. Eventually, the stereo indicator will go off and the sound will fade completely as you get out of range of the station’s signal.

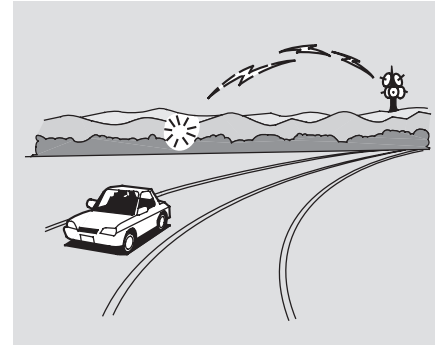

Driving very near the transmitter of a station that is broadcasting on a frequency close to the frequency of the station you are listening to can also affect your radio’s reception. You may temporarily hear both stations, or hear only the station you are close to.

AM/FM Radio Reception

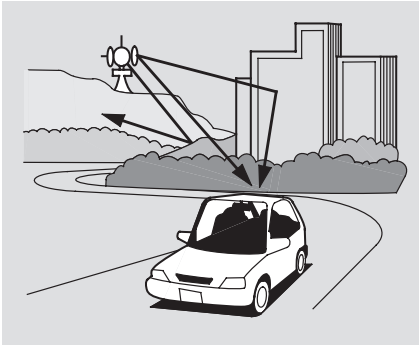

Radio signals, especially on the FM band, are deflected by large objects such as buildings and hills. Your radio then receives both the direct signal from the station's transmitter, and the deflected signal. This causes the sound to distort or flutter. This is a main cause of poor radio reception in city driving.



Radio reception can be affected by atmospheric conditions such as thunderstorms, high humidity, and even sunspots. You may be able to receive a distant radio station one day and not receive it the next day because of a change in conditions.

Electrical interference from passing vehicles and stationary sources can cause temporary reception problems.

*As required by the FCC:
Changes or modifications not expressly
approved by the party responsible for
compliance could void the user's
authority to operate the equipment.*

Playing the XM® Satellite Radio

XM Satellite Radio

U.S. EX models

Your vehicle is capable of receiving XM® Satellite Radio anywhere in the United States, except Hawaii and Alaska.

XM® is a registered trademark of XM Satellite Radio, Inc.

Satellite radio is only available on U.S. models.

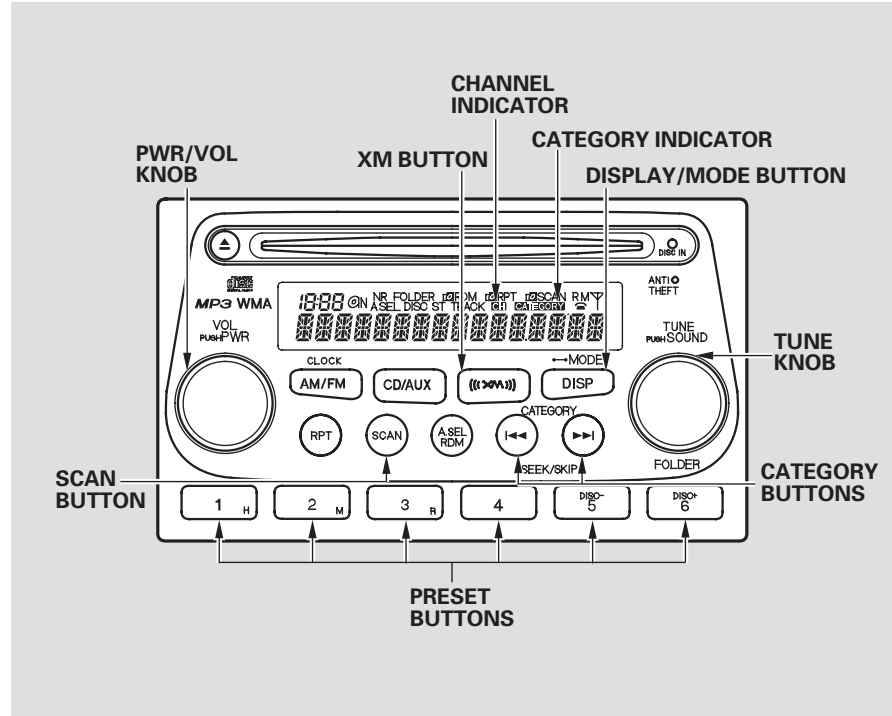

XM radio receives signals from two satellites to produce clear, high-quality digital reception. It offers many channels in several categories. Along with a large selection of different types of music, XM radio allows you to view channel and category selections in the display.

Operating the Satellite Radio

To listen to XM radio, turn the ignition switch to the ACCESSORY (I) or the ON (II) position. Push the PWR/VOL knob to turn on the audio system, and press the “XM” button. Adjust the volume by turning the PWR/VOL knob. The last channel you listened to will show in the display.

MODE – To switch between channel mode and category mode, press and hold the DISP/MODE button until the mode changes.

In the channel mode, you can select all of the available channels. In the category mode, such as Jazz, Rock, Classical, etc., you can select all of the channels within that category.

Each time you press and release the DISP/MODE button, the display changes in the following sequence: channel name, channel number, category, artist name, and music title.

You may experience periods when XM Radio does not transmit the artist’s name and song title information. If this happens, there is nothing wrong with your system.

TUNE – Turn the TUNE knob left or right to select channels. In the category mode, you can only select channels within that category.

CATEGORY (**◀◀** or **▶▶**) – In the category mode, press either button to select another category.

CONTINUED

Playing the XM® Satellite Radio

SCAN – The scan function gives you sampling of all channels while in the channel mode. In the category mode, only the stations within that category are scanned. To activate scan, press the SCAN button. The system plays each channel in numerical order for 5 seconds, then selects the next channel. When you hear a channel you want to continue listening to, press the button.

Preset – You can store up to 12 preset channels using the six preset buttons. Each button stores one channel from the XM1 band and one channel from the XM2 band.

To store a channel:

1. Press the XM button. Either XM1 or XM2 will show in the display.
2. Use the TUNE knob, or the CATEGORY or SCAN buttons to tune to a desired channel.

In category mode, only channels within that category can be selected. In channel mode, all channels can be selected.

3. Pick the preset button you want for that channel. Press and hold the button until you hear a beep.
4. Repeat steps 2 and 3 to store the first six channels.

5. Press the XM button again. The other XM band will show. Store the next six channels using steps 2 and 3.

Once a channel is stored, press and release the proper preset button to tune to it.

XM Radio Display Messages

“LOADING” – XM is loading the audio or program information.

“OFF AIR” – The channel currently selected is no longer broadcasting.

“UPDATING” – The encryption code is being updated. Wait until the encryption code is fully updated. Channels 0 and 1 should still work normally.

“NO SIGNAL” – The signal is currently too weak. Move the vehicle to an area away from tall buildings, and with an unobstructed view of the southern horizon.

“ - - - - ” – The selected channel number does not exist or is not part of your subscription, or this channel has no artist or title information at this time.

“ANTENNA” – There is a problem with the XM antenna. Please consult your dealer.

Playing the XM® Satellite Radio

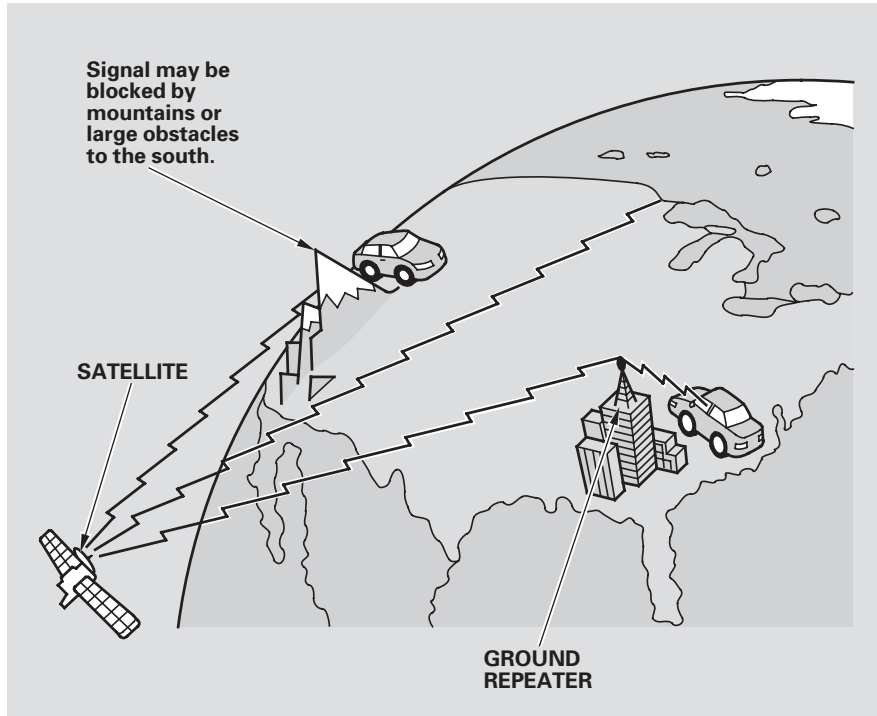

The XM satellites are in orbit over the equator; therefore, objects south of the vehicle may cause satellite reception interruptions. To help compensate for this, ground-based repeaters are placed in major metropolitan areas.

Satellite signals are more likely to be blocked by tall buildings and mountains the farther north you travel from the equator. Carrying large items on a roof rack can also block the signal.

Depending on where you drive, you may experience reception problems. Interference can be caused by any of these conditions:

- Driving on the north side of an east/west mountain road.
- Driving on the north side of a large commercial truck on an east/west road.
- Driving in tunnels.
- Driving on a road beside a vertical wall, steep cliff, or hill to the south of you.
- Driving on the lower level of a multi-tiered road.
- Driving on a single lane road alongside dense trees taller than 50 ft. (15 m) to the south of you.
- Large items carried on a roof rack.

There may be other geographic situations that could affect XM radio reception.

*As required by the FCC:
Changes or modifications not expressly approved by the party responsible for compliance could void the user's authority to operate the equipment.*

Receiving Satellite Radio Service

If your XM Radio service has expired or you purchased your vehicle from a previous owner, you can listen to a sampling of the broadcasts available on XM Satellite Radio. With the ignition switch in the ACCESSORY (I) or ON (II) position, push the PWR/VOL knob to turn on the audio system and press the XM button. A variety of music types and styles will play.

If you decide to purchase XM satellite radio service, contact XM Radio at www.xmradio.com, or at 1-800-852-9696. You will need to give them your radio I.D. number and your credit card number. To get your radio I.D. number, turn the TUNE

knob until "0" appears in the display. Your I.D. will appear in the display.

After you have registered with XM Radio, keep your audio system in the satellite radio mode while you wait for activation. This should take about 30 minutes.

While waiting for activation, make sure your vehicle remains in an open area with good reception. Once your audio system is activated, you'll be able to listen to XM radio broadcasts. XM Radio will continue to send an activation signal to your vehicle for at least 12 hours from the activation request. If the service has not been activated after 36 hours, contact XM Radio.

Playing a Disc

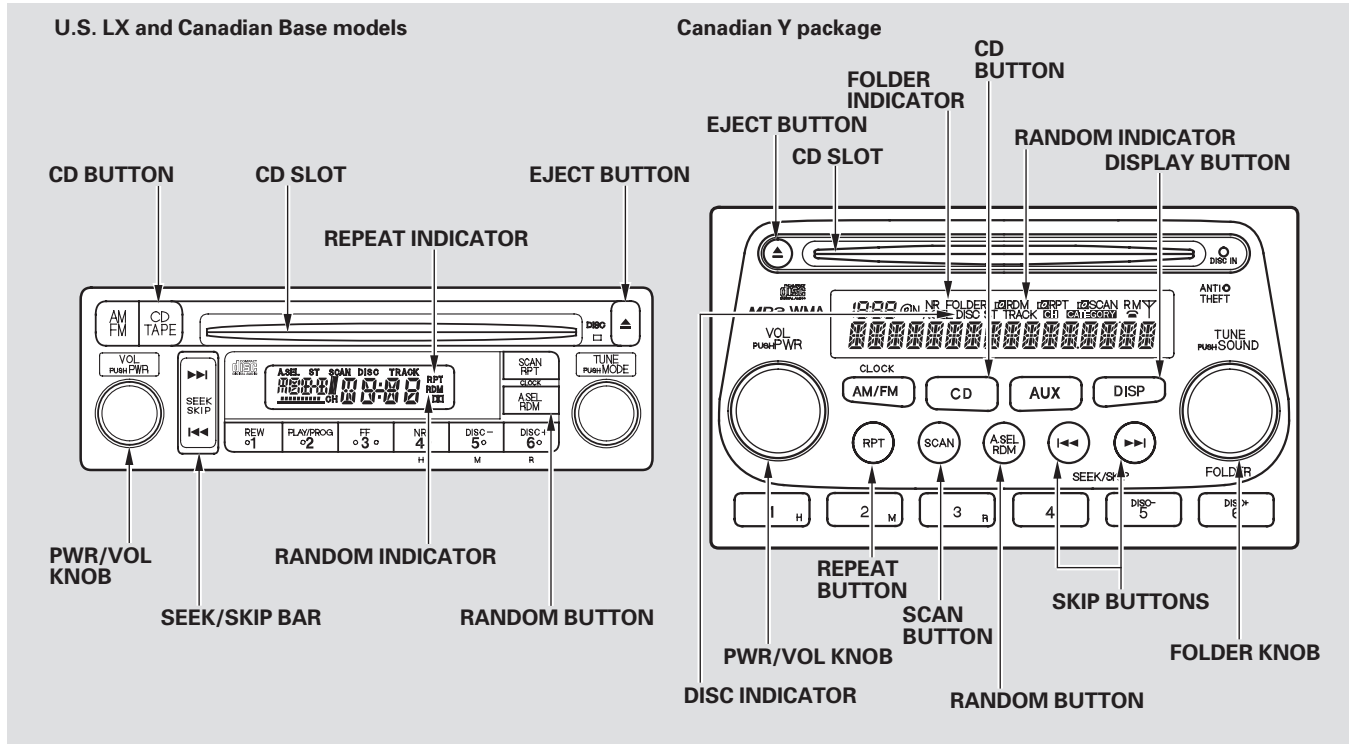

U.S. EX models

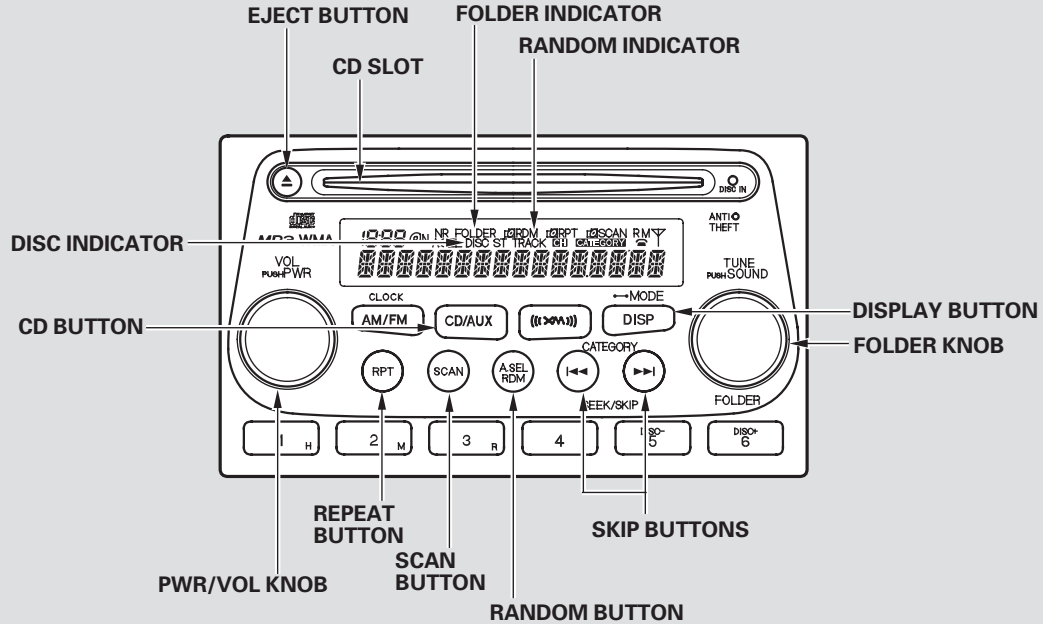

Features

Playing a Disc

To Play a Disc

To load or play discs, the ignition switch must be in the ACCESSORY (I) or ON (II) position.

NOTICE

Do not use discs with adhesive labels. The label can curl up and cause the disc to jam in the unit.

You operate the disc player with the same controls used for the radio. To select the disc player, press the CD/AUX button. You will see “CD” in the display. The number of the track playing is shown in the display. The system will continuously play a disc until you change modes.

On U.S. EX models and Canadian Y package

The disc player can also play CD-Rs WMA files, and CD-RWs compressed in MP3 standard. When playing a disc in MP3, you will see “MP3” in the display. You can select up to 255 folders or tracks.

Note:

- Because the compressed audio format of MP3 and WMA discs allows them to store large amounts of files and tagging information, these discs may take more time to begin playing.
- The sound quality of MP3 and WMA discs generally degrades as the bit rate increases.
- If a file on an MP3 or WMA disc is protected by digital rights management (DRM), the audio unit displays FORMAT, and then skips to the next file.

Video CDs and DVDs will not work in this unit.

The specifications of the compatible MP3 file are:

Sampling frequency: 32/44.1/48 kHz
Bit rate: 8/16/24/32/40/48/56/64/80/96/112/128/160/192/224/256/320 kbps

Compatible with variable bit rate and multi-session.

Maximum layers (including ROOT):
8

Insert a disc into the slot. The drive will pull the disc in the rest of the way to play it. When the system reaches the end of the disc, it will return to the beginning and play the disc again.

You can also play 3-inch (8-cm) discs without using an adapter ring.

To play the radio when a disc is playing, press the AM/FM button. Press the CD/AUX button again to switch back to the disc player.

If you turn the system off while a disc is playing, either with the PWR/VOL knob or by turning off the ignition switch, the disc will stay in the drive. When you turn the system back on, the disc will begin playing where it left off.

If you press the DISP/MODE button while playing a disc, additional information (track, album, artist, etc.) may be displayed.

To Change or Select Tracks/Files

Use the SEEK/SKIP button while a disc is playing to select passages and change tracks (files in MP3/WMA mode).

In MP3/WMA mode, use the FOLDER knob to select folders in the disc, and use the SEEK/SKIP button to change files.

SEEK/SKIP — Each time you press and release the ►►, the player skips forward to the beginning of the next track (files in MP3/WMA mode). Press and release the ◀◀ to skip backward to the beginning of the current track. Press it again to skip to the beginning of the previous track.

To move rapidly within a track, press and hold ►► or ◀◀.

Except EX models

You will see CUE or REW in the display while moving within a track.

CONTINUED

Playing a Disc

On U.S. EX models and Canadian Y package

REPEAT (TRACK/FILE

REPEAT) – To continuously replay a track (files in MP3/WMA mode), press and release the RPT button. You will see RPT in the display. Press the RPT button again to turn it off.

In MP3/WMA mode

FOLDER SELECTION – To select a different folder, use the FOLDER knob to move to the beginning of the next folder. Turn the knob right to move to the beginning of the current folder. Turn the knob left to skip to the beginning of the previous folder.

FOLDER-REPEAT – This feature, when activated, replays all the files on the selected folder in the order they are compressed in MP3/WMA. To activate folder repeat, press and hold the RPT button for 2 seconds. You will see  RPT in the display. The system continuously replays the current folder. Press and hold the RPT button for 2 seconds to turn it off.

RANDOM (Random within a Disc) – This feature plays the tracks (all files in each folder in MP3/WMA mode) within a disc in random order. To activate random play, press and release the RDM button. You will see RDM in the display. Press the RDM button again to return to normal play.

FOLDER-RANDOM – This feature, when activated, plays the files within a folder in random order, rather than in the order they are compressed in MP3/WMA. To activate folder random play, press and hold the RDM button. You will see  RDM in the display. The system will then select and play files randomly. This continues until you deactivate folder random play by pressing the RDM button again or selecting a different folder with the FOLDER knob.

SCAN – The scan function samples all tracks/files on the selected disc in the order they are recorded. To activate scan, press and hold the SCAN button until you hear a beep. You will see SCAN in the display. You will get a 10 second sampling of each track/file on the selected disc. Press the SCAN button again to exit scan and play the last track/file sampled.

Pressing either side of the SEEK/SKIP button also turns off scan.

FOLDER SCAN – This feature, when activated, samples all files on the selected folder in order. To activate folder scan, press and hold the SCAN button until you hear a beep. You will see  SCAN in the display. The system will then play the first file for about 10 seconds. If you do nothing, the system will then play the first file in each folder for 10 seconds. When it plays a file you want to continue listening to, press the SCAN button again.

Pressing either side of the SEEK/SKIP button or selecting a different folder with the FOLDER knob also turns off folder scan.

To Stop Playing a Disc

Press the eject button () to remove the disc. If you eject the disc, but do not remove it from the slot, the system will automatically reload the disc after 15 seconds and put it in pause mode. To begin playing, press the CD/AUX button.

Press the AM/FM button to switch to the radio while a disc is playing. To play the disc, press the CD button.

If you turn the system off while a disc is playing, either with the PWR/VOL knob or by turning off the ignition switch, the disc will stay in the drive. When you turn the system back on, the disc will begin playing where it left off.

Playing a Disc

Auxiliary Input Jack

If equipped

The auxiliary input jack is on the dashboard next to the accessory power socket. The system will accept auxiliary input from standard audio accessories.

When the accessory is connected to the auxiliary input jack, press the AUX button to select it.

Audio System Malfunction

See pages [114](#) and [115](#) for information on error messages.

Protecting Discs

For information on how to handle and protect discs, see page [113](#).

Operating the Optional Disc Changer

An optional six disc changer is available for your vehicle. This disc changer uses the same controls used for the in-dash disc player or the radio.

Load the desired discs in the magazine, and load the magazine in the changer according to the instructions that came with the unit.

To select the disc changer, press the CD/AUX button. The disc and track numbers will be displayed. To select a different disc, use the preset 5 (DISC -) or the preset 6 (DISC +) button. To select the previous disc, press the preset 5 (DISC -), or the preset 6 (DISC +) to select the next disc in sequence.

If you select an empty slot in the magazine, the changer will search for the next available disc to load and play.

General Information

- When using CD-R or CD-RW discs, use only high quality CDs labeled for audio use.
- When recording a CD-R or CD-RW, the recording must be closed for it to be used by the system.
- Play only standard round discs. Odd-shaped discs may jam in the drive or cause other problems.
- Handle your discs properly to prevent damage and skipping.

Protecting Discs

When a disc is not being played, store it in its case to protect it from dust and other contamination. To prevent warpage, keep discs out of direct sunlight and extreme heat.

To clean a disc, use a clean soft cloth. Wipe across the disc from the center to the outside edge.

A new disc may be rough on the inner and outer edges. The small plastic pieces causing this roughness can flake off and fall on the recorded surface of the disc, causing skipping or other problems. Remove these pieces by rubbing the inner and outer edges with the side of a pencil or pen.

Never try to insert foreign objects in the CD player or the magazine.

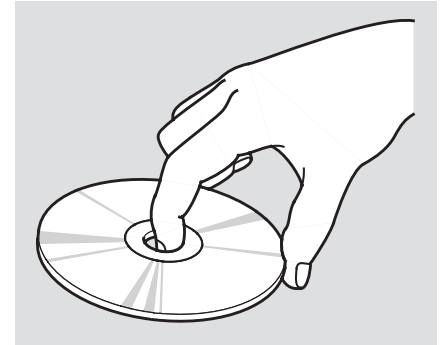

Handle a disc by its edges; never touch either surface. Do not place stabilizer rings or labels on the disc. These, along with contamination from finger prints, liquids, and felt-tip pens, can cause the disc to not play properly, or possibly jam in the drive.

Disc Player Error Messages

If you see an error message in the display while playing a disc, find the cause in the chart to the right. If you cannot clear the error message, take the vehicle to your dealer.

Indication		Cause	Solution
①	CD DISC ERROR	FOCUS error	Press the EJECT button and pull out the disc. Check if it is inserted correctly in the player. Make sure the disc is not scratched or damaged.
②	CD DISC		
①	CD MECH ERROR	Mechanical error	Press the EJECT button and pull out the disc. Check the disc for damage or deformation. If the disc cannot be pulled out, or the error message does not disappear after the disc is ejected, see your dealer.
②	CD ERR		
①	CD HEAT ERROR	High temperature	Will disappear when the temperature returns to normal.
②	CD Hot		

①: U.S. EX models and Canadian Y package

②: Except U.S. EX models and Canadian Y package

Disc Changer Error Messages

If you see an error message in the display while playing a disc, find the cause in the chart to the right. If you cannot clear the error message, take the vehicle to your dealer.

Indication		Cause	Solution
①	CDC DISC ERROR	FOCUS error	Press the magazine eject button, and pull the magazine out. If the message does not disappear or the magazine cannot be pulled out, see your dealer.
②	C02 DISC		
①	CDC NO DISC	No disc in the magazine	Insert disc.
②	C02 NO		
①	CDC MECH ERROR	Mechanical error	Press the magazine eject button, and pull the magazine out. Check for an error message, and insert the magazine again. If the message does not disappear or the magazine cannot be pulled out, see your dealer.
②	C03 ERR		
①	CDC HEAT ERROR	High temperature	Will disappear when the temperature returns to normal.
②	C02 HOT		
①	CDC EJECT	No magazine in the changer	Insert magazine.
②	C02 EJECT		

①: U.S. EX models and Canadian Y package

②: Except U.S. EX models and Canadian Y package

Radio Theft Protection

On U.S. EX models and Canadian Y package

Your vehicle's audio system will disable itself if it is disconnected from electrical power for any reason. To make it work again, you must enter a specific five-digit code in the preset buttons. Because there are hundreds of number combinations possible from five-digits, making the system work without knowing the exact code is nearly impossible.

You should have received a card that lists your audio system's code and serial numbers. It is best to store this card in a safe place at home. In addition, you should write the audio system's serial number in this owner's manual.

If you lose the card, you must obtain the code number from a dealer. To do this, you will need the system's serial number.

If your vehicle's battery is disconnected or goes dead, or the radio fuse is removed, the audio system will disable itself. If this happens, you will see "CODE" in the frequency display the next time you turn on the system. Use the preset buttons to enter the five-digit code. The code is on the radio code card included in your Owner's Manual kit. When it is entered correctly, the radio will start playing.

If you make a mistake entering the code, do not start over; complete the five-digit sequence, then enter the correct code. You have 10 tries to enter the correct code. If you are unsuccessful in 10 attempts, you must then leave the system on for 1 hour before trying again.

Setting the Clock

If your vehicle's battery is disconnected or goes dead, you will need to set the clock.

U.S. LX and Canadian Base models

To set the hour, press the H button while pressing the CLOCK (SCAN/RPT) button until the hour advances to the desired time. Change the minute by pressing the M button while pressing the CLOCK (SCAN/RPT) button until the minute advances to the desired time.

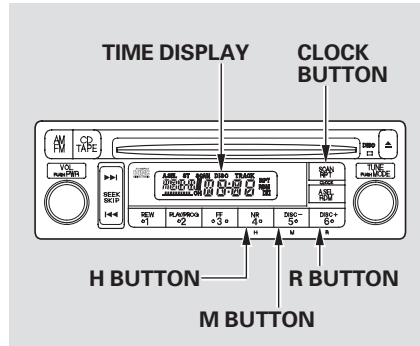

You can use the R button to quickly set the time to the nearest hour. Press the R button while pressing the CLOCK button. If the displayed time is before the half hour, pressing R sets the clock back to the previous hour. If the displayed time is after the half hour, pressing R sets the clock forward to the beginning of the next hour.

For example:

1:06 will reset to 1:00

1:53 will reset to 2:00

On U.S. EX models

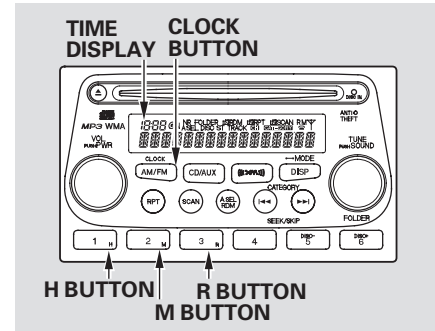

Press and hold the CLOCK button until the numbers flash and you hear a beep. Change the hour by pressing the H button until the numbers advance to the desired time. Change the minute by pressing the M button until the numbers advance to the desired time.

CONTINUED

Setting the Clock

On Canadian Y package

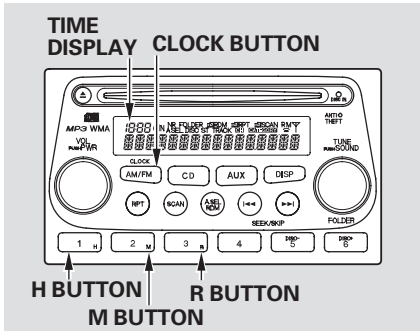

You can quickly set the time to the nearest hour. If the displayed time is before the half hour, press the R (RESET) button to set the clock back to the previous hour. If the displayed time is after the half hour, pressing R sets the clock forward to the beginning of the next hour.

For example:

1:06 will reset to 1:00

1:53 will reset to 2:00

When you are finished, press the CLOCK button again.

On all models except Canadian Base model

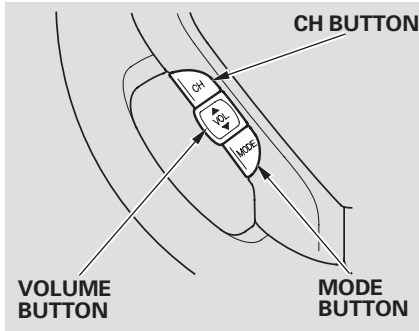

Three controls for the audio system are mounted in the steering wheel hub. These let you control basic functions without removing your hand from the wheel.

The middle button adjusts the volume up (▲) or down (▼). Press the top or bottom of the button and hold it until the desired volume is reached, then release it.

The MODE button changes the mode. Pressing the button repeatedly selects FM1, FM2, AM or CD (if a CD is loaded).

The CHANNEL button has two functions, depending on whether you are listening to the radio, or playing a CD.

If you are listening to the radio, use the CH button to change stations. Each time you press this button, the system advances to the next preset station on the band you are listening to. You will see the number of the selected Preset button in the display. To change bands, or to change from FM1 to FM2, press the MODE button.

If you are playing a CD, the system skips to the beginning of the next track each time you push the CH button. You will see the disc and track number in the display.

Cruise Control

If equipped

Cruise control allows you to maintain a set speed above 25 mph (40 km/h) without keeping your foot on the accelerator pedal. It should be used for cruising on straight, open highways. It is not recommended for city driving, winding roads, slippery roads, heavy rain, or bad weather.

⚠ WARNING

Improper use of the cruise control can lead to a crash.

Use the cruise control only when traveling on open highways in good weather.

Using Cruise Control

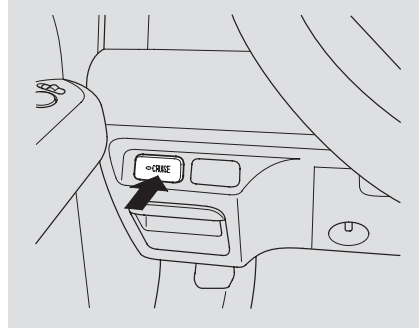

1. Push in the cruise control master button. The indicator in the button comes on.
2. Accelerate to the desired cruising speed above 25 mph (40 km/h).
3. Press and release the SET/DECEL button on the steering wheel. The indicator on the instrument panel comes on to show the system is now activated.

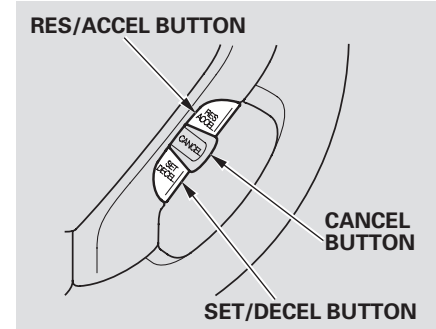

Cruise control may not hold the set speed when you are going up and down hills. If your speed increases going down a hill, use the brakes to slow down. This will cancel cruise control. To resume the set speed, press the RES/ACCEL button. The indicator on the instrument panel will come back on.

Changing the Set Speed

You can increase the set cruising speed in any of these ways:

- Press and hold the RES/ACCEL button. When you reach the desired cruising speed, release the button.
- To increase the speed in very small amounts, tap the RES/ACCEL button. Each time you do this, your vehicle speeds up about 1 mph (1.6 km/h).
- Push on the accelerator pedal. Accelerate to the desired cruising speed, and press the SET/DECEL button.

You can decrease the set cruising speed in any of these ways:

- Press and hold the SET/DECEL button. Release the button when you reach the desired speed.

- To slow down in very small amounts, tap the SET/DECEL button. Each time you do this, your vehicle will slow down about 1 mph (1.6 km/h).
- Tap the brake or clutch pedal lightly with your foot. The CRUISE CONTROL indicator on the instrument panel goes out. When the vehicle slows to the desired speed, press the SET/DECEL button.

Even with cruise control turned on, you can still use the accelerator pedal to speed up for passing. After completing the pass, take your foot off the accelerator pedal. The vehicle will return to the set cruising speed.

Resting your foot on the brake or clutch pedal causes cruise control to cancel.

Cancelling Cruise Control

You can cancel cruise control in any of these ways:

- Tap the brake or clutch pedal.
- Push the CANCEL button on the steering wheel.
- Push the cruise control master button.

Resuming the Set Speed

When you push the CANCEL button, or tap the brake or clutch pedal, the system remembers the previously set cruising speed. To return to that speed, accelerate to above 25 mph (40 km/h), then press and release the RES/ACCEL button. The indicator comes on, and the vehicle accelerates to the same cruising speed as before.

Pressing the cruise control master button turns the system off and erases the previous cruising speed.

Before you begin driving your vehicle, you should know what gasoline to use and how to check the levels of important fluids. You also need to know how to properly store luggage or packages. The information in this section will help you. If you plan to add any accessories to your vehicle, please read the information in this section first.

Break-in Period	124
Fuel Recommendation	124
Service Station Procedures	126
Refueling.....	126
Opening and Closing the Hood	127
Oil Check	128
Engine Coolant Check	128
Fuel Economy	129
Accessories and Modifications	130
Carrying Cargo	132

Break-in Period, Fuel Recommendation

Break-in Period

Help assure your vehicle's future reliability and performance by paying extra attention to how you drive during the first 600 miles (1,000 km). During this period:

- Avoid full-throttle starts and rapid acceleration.
- Do not change the oil until the scheduled maintenance time.
- Avoid hard braking for the first 200 miles (300 km).
- Do not tow a trailer.

You should also follow these recommendations with an overhauled or exchanged engine, or when the brakes are replaced.

Fuel Recommendation

Your vehicle is designed to operate on unleaded gasoline with a pump octane number of 87 or higher. Use of a lower octane gasoline can cause a persistent, heavy metallic rapping noise that can lead to engine damage.

On vehicles with manual transmission

You may hear a knocking noise from the engine if you drive the vehicle at low engine speed (below about 1,000 rpm) in a higher gear. To stop this, raise the engine speed by shifting to a lower gear.

We recommend quality gasoline containing detergent additives that help prevent fuel system and engine deposits.

In addition, in order to maintain good performance, fuel economy, and emissions control, we strongly recommend, in areas where it is available, the use of gasoline that does NOT contain manganese-based fuel additives such as MMT.

Some gasoline today is blended with oxygenates such as ethanol or MTBE. Your vehicle is designed to operate on oxygenated gasoline containing up to 10 % ethanol by volume and up to 15 % MTBE by volume. Do not use gasoline containing methanol.

If you notice any undesirable operating symptoms, try another service station or switch to another brand of gasoline.

For further important fuel-related information, please refer to your **Quick Start Guide**.

Service Station Procedures

Refueling

1. Park with the driver's side closest to the gas pump.
2. Outside of the vehicle, locate and open the fuel fill door by pulling on the notched edge.

WARNING

Gasoline is highly flammable and explosive. You can be burned or seriously injured when handling fuel.

- Stop the engine, and keep heat, sparks, and flame away.
- Handle fuel only outdoors.
- Wipe up spills immediately.

3. Remove the fuel fill cap slowly. You may hear a hissing sound as pressure inside the tank escapes. Place the cap in the holder on the fuel fill door.
4. Stop filling the tank after the fuel nozzle automatically clicks off. Do not try to “top off” the tank. Leave some room for the fuel to expand with temperature changes.

If the fuel nozzle keeps clicking off even though the tank is not full, there may be a problem with your vehicle's fuel vapor recovery system. The system helps keep fuel vapors from going into the atmosphere. Try filling at another pump. If this does not fix the problem, consult your dealer.

5. Screw the fuel fill cap back on until it clicks at least three times. If you do not properly tighten the cap, the malfunction indicator lamp may come on (see page [210](#)).
6. Push the fuel fill door closed.

Opening and Closing the Hood

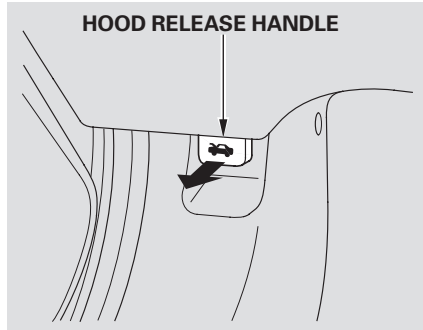

1. Park the vehicle, and set the parking brake. Pull the hood release handle located under the lower left corner of the dashboard. The hood will pop up slightly.
2. Put your fingers under the front edge of the hood near the center. The hood latch handle is above the "H" logo. Push this handle up to release it. Lift up the hood.

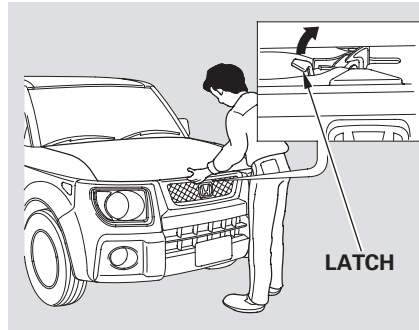

If the hood latch handle moves stiffly, or if you can open the hood without lifting the handle, the mechanism should be cleaned and lubricated.

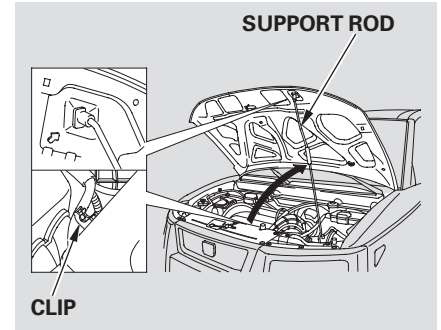

3. Pull the support rod out of its clip and insert the end into the hole in the hood.

To Close the Hood:

Lift it up slightly to remove the support rod from the hole. Put the support rod back into its holding clip. Lower the hood to about a foot (30 cm) above the fender, then let it drop. Make sure it is securely latched.

Service Station Procedures

Oil Check

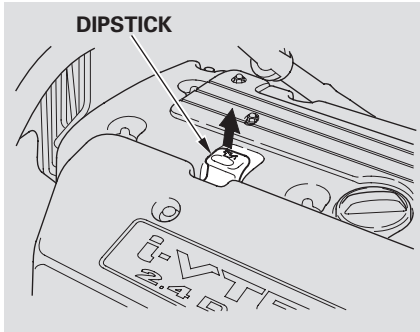

Wait a few minutes after turning the engine off before you check the oil.

1. Remove the dipstick (orange tab).
2. Wipe the dipstick with a clean cloth or paper towel.
3. Insert it all the way back in its tube.

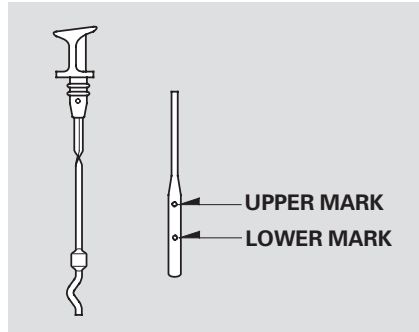

4. Remove the dipstick again, and check the level. It should be between the upper and lower marks.

If it is near or below the lower mark, see **Adding Engine Oil** on page [170](#).

Engine Coolant Check

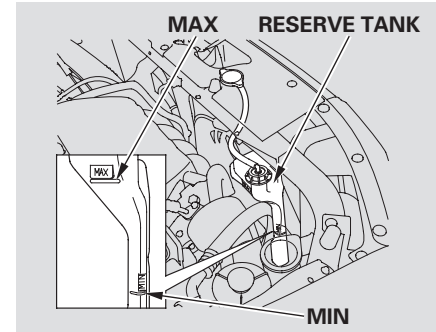

Look at the coolant level in the radiator reserve tank. Make sure it is between the MAX and MIN lines. If it is below the MIN line, see **Adding Engine Coolant** on page [173](#) for information on adding the proper coolant.

Refer to **Owner's Maintenance Checks** on page [164](#) for information about checking other items on your vehicle.

Improving Fuel Economy

- Always maintain your vehicle according to the maintenance schedule. See **Owner's Maintenance Checks** on page 164 .

For example, an underinflated tire causes more “rolling resistance,” which uses more fuel.

- The build-up of snow or mud on your vehicle’s underside adds weight and rolling resistance. Frequent cleaning helps your fuel mileage and reduces the chance of corrosion.
- Drive moderately. Rapid acceleration, abrupt cornering, and hard braking use more fuel.
- Always drive in the highest gear possible.

- Try to maintain a constant speed. Every time you slow down and speed up, your vehicle uses extra fuel. Use cruise control when appropriate.
- Combine several short trips into one.
- The air conditioning puts an extra load on the engine which makes it use more fuel. Use the fresh-air ventilation when possible.

Accessories and Modifications

Modifying your vehicle, or installing some non-Honda accessories, can make it unsafe. Before you make any modifications or add any accessories, be sure to read the following information.

Accessories

Your dealer has Honda accessories that allow you to personalize your vehicle. These accessories have been designed and approved for your vehicle, and are covered by warranty.

Although non-Honda accessories may fit on your vehicle, they may not meet factory specifications, and could adversely affect your vehicle's handling and stability.

WARNING

Improper accessories or modifications can affect your vehicle's handling, stability, and performance, and cause a crash in which you can be hurt or killed.

Follow all instructions in this owner's manual regarding accessories and modifications.

When properly installed, cellular phones, alarms, two-way radios, and low-powered audio systems should not interfere with your vehicle's computer controlled systems, such as your airbags and anti-lock brakes.

Before installing any accessory:

- Make sure the accessory does not obscure any lights, or interfere with proper vehicle operation or performance.
- Be sure electronic accessories do not overload electrical circuits (see page 212) or interfere with proper the operation of your vehicle.
- Before installing any electronic accessory, have the installer contact your dealer for assistance. If possible, have your dealer inspect the final installation.

Modifying Your Vehicle

Removing parts from your vehicle, or replacing components with some non-Honda components could seriously affect your vehicle's handling, stability, and reliability.

Some examples are:

- Lowering the vehicle with a non-Honda suspension kit that significantly reduces ground clearance can allow the undercarriage to hit speed bumps or other raised objects, which could cause the airbags to deploy.
- Raising your vehicle with a non-Honda suspension kit can affect the handling and stability.
- Non-Honda wheels can cause excessive stress on suspension components.

- Larger or smaller wheels and tires can interfere with the operation of your vehicle's anti-lock brakes and other systems.
- Modifying your steering wheel or any other part of your vehicle's safety features can make the systems ineffective.

If you plan to modify your vehicle, consult your dealer.

Carrying Cargo

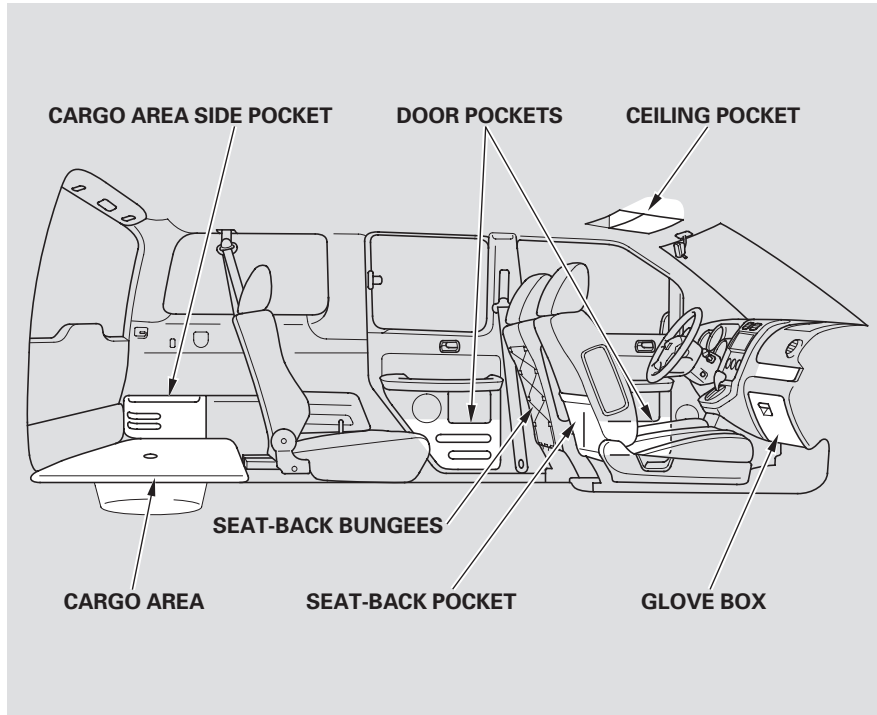

Your vehicle has several convenient storage areas:

- Cargo area side pockets
- Glove box
- Ceiling pocket (U.S. EX models and Canadian Y package)
- Door pockets
- Seat-back pocket (U.S. EX models and Canadian Y package)
- Cargo area (including rear seats when they are folded down, folded to the side, or removed)
- Seat-back bungees (U.S. EX models and Canadian Y package)
- Roof rack (if installed)

However, carrying too much cargo, or improperly storing it, can affect your vehicle's handling, stability, stopping distance, and tires, and make it unsafe. Before carrying any type of cargo, be sure to read the following pages.

Load Limits

The maximum load for your vehicle is 675 lbs (308 kg). This figure includes the total weight of all occupants, cargo, and accessories, and the tongue load if you are towing a trailer.

WARNING

Overloading or improper loading can affect handling and stability and cause a crash in which you can be hurt or killed.

Follow all load limits and other loading guidelines in this manual.

Steps for determining correct load limit:

1. Locate the statement, “the combined weight of occupants and cargo should never exceed 675 lbs” on your vehicle’s placard. [The placard is on the driver’s doorjamb.]
2. Determine the combined weight of the driver and passengers that will be riding in your vehicle.
3. Subtract the combined weight of the driver and passengers from 675 pounds or 308 kilograms.
4. The resulting figure equals the available amount of cargo and luggage load capacity.

For example, if the maximum load is 675 lbs and there will be four 150 lb. passengers in your vehicle, the amount of available cargo and

luggage load capacity is 75 lbs.
(675 – 600 (4 × 150) = 75 lbs.)

5. Determine the combined weight of luggage and cargo being loaded in the vehicle. That weight may not safely exceed the available cargo and luggage load capacity in step 4.
6. If your vehicle will be towing a trailer, the load from your trailer will be transferred to your vehicle. Consult this manual to determine how this reduces the available cargo and luggage load capacity of your vehicle (see page 151).

CONTINUED

Carrying Cargo

In addition, the total weight of the vehicle, all passengers, accessories, cargo, and trailer tongue load must not exceed the Gross Vehicle Weight Rating (GVWR) or the Gross Axle Weight Rating (GAWR). Both are on a label on the driver's doorjamb.

Carrying Items in the Passenger Compartment

- Store or secure all items that could be thrown around and hurt someone during a crash.
- Be sure items placed on the floor behind the front seats cannot roll under the seats and interfere with the driver's ability to operate the pedals or the proper operation of the seats.
- Keep the glove box closed while driving. If it is open, a passenger could injure their knees during a crash or sudden stop.

- If you fold the rear seats down, fold them up, or remove them, tie down items that could be thrown about the vehicle during a crash or sudden stop.

Carrying Cargo in the Cargo Area or on a Roof Rack

- Distribute cargo evenly on the floor of the cargo area, placing the heaviest items on the bottom and as far forward as possible. Tie down items that could be thrown about the vehicle during a crash or sudden stop.
- If you carry large items that prevent you from closing the tailgate or the hatch, exhaust gas can enter the passenger area. To avoid the possibility of **carbon monoxide poisoning**, follow the instructions on page 47 .

- If you carry any items on a roof rack, be sure the total weight of the rack and the items does not exceed 165 lbs (75 kg).

If you use an accessory roof rack, the roof rack weight limit may be lower. Refer to the information that came with your roof rack.

Optional Separation Net

The separation net can be used to hold back soft, lightweight items stored in the cargo area. Heavy items should be properly secured on the floor of the cargo area. The net may not prevent heavy items from being thrown forward in a crash or a sudden stop.

Seat-Back Bungee

If equipped

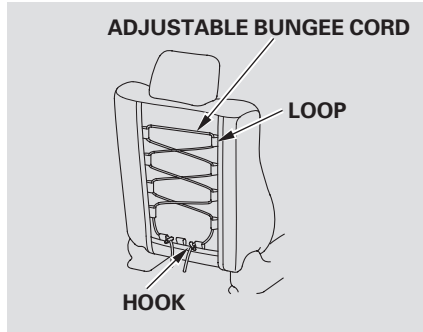

The driver's seat-back and left rear seat-back are equipped with adjustable bungee cords to hold medium-sized, lightweight objects.

If the cords are not installed, route one cord through the loops as shown. To attach the hooks, press the top of the hook down, and slide to the desired position, then release. Adjust as needed.

This section gives you tips on starting the engine under various conditions, and how to operate the manual and automatic transmissions. It also includes important information on parking your vehicle, the braking system, and facts you need if you are planning to tow a trailer or drive off-highway.

Driving Guidelines.....	138
Preparing to Drive	139
Starting the Engine.....	140
Manual Transmission.....	141
Automatic Transmission.....	143
Parking	147
Braking System.....	148
Anti-lock Brakes (ABS)	149
Towing a Trailer	151
Off-Highway Driving Guidelines.....	157

Driving Guidelines

Your vehicle has a higher ground clearance that allows you to travel over bumps, obstacles, and rough terrain. It also provides good visibility so you can anticipate problems earlier.

Because your vehicle rides higher off the ground, it has a high center of gravity that can cause it to roll over if you make abrupt turns. Utility vehicles have a significantly higher roll over rate than other types of vehicles.

To prevent rollovers or loss of control:

- Take corners at slower speeds than you would with a passenger vehicle.
- Avoid sharp turns and abrupt maneuvers whenever possible.

- Do not modify your vehicle in any way that would raise the center of gravity.
- Do not carry heavy cargo on the roof.

Four-wheel drive models

Your vehicle is equipped with a four-wheel drive (4WD) system. When the system senses a loss of front-wheel traction, it automatically transfers some power to the rear wheels. This gives you better traction and mobility.

You still need to exercise the same care when accelerating, steering, and braking that you would in a two-wheel drive vehicle.

See page 157 for off-highway driving guidelines.

You should do the following checks and adjustments before you drive your vehicle.

1. Make sure all windows, mirrors, and outside lights are clean and unobstructed. Remove frost, snow, or ice.
2. Check that the hood is fully closed.
3. Visually check the tires. If a tire looks low, use a gauge to check its pressure.
4. Check that any items you may be carrying with you inside are stored properly or fastened down securely.
5. Check the seat adjustment (see page [73](#)).
6. Check the adjustment of the inside and outside mirrors (see page [82](#)).
7. Check the steering wheel adjustment (see page [64](#)).
8. Make sure the doors, hatch, and tailgate are securely closed and locked.
9. Fasten your seat belt. Check that your passengers have fastened their seat belts (see page [15](#)).
10. When you start the engine, check the gauges and indicators in the instrument panel (see page [53](#)).

Starting the Engine

1. Apply the parking brake.
2. In cold weather, turn off all electrical accessories to reduce the drain on the battery.
3. *Manual transmission:*
Push the clutch pedal down all the way.

Automatic transmission:

Make sure the shift lever is in Park. Press on the brake pedal.

4. Without touching the accelerator pedal, turn the ignition key to the START (III) position. Do not hold the key in the START (III) position for more than 15 seconds at a time. If the engine does not start right away, pause for at least 10 seconds before trying again.

NOTICE

The immobilizer system protects your vehicle from theft. If an improperly-coded key (or other device) is used, the engine's fuel system is disabled. For more information, see page 66.

5. If the engine does not start within 15 seconds, or starts but stalls right away, repeat step 4 with the accelerator pedal pressed halfway down. If the engine starts, release pressure on the accelerator pedal so the engine does not race.
6. If the engine fails to start, press the accelerator pedal all the way down, and hold it there while starting to clear flooding. If the engine still does not start, return to step 5.

NOTICE

The engine is harder to start in cold weather. Also, the thinner air found at altitudes above 8,000 feet (2,400 meters) adds to this problem.

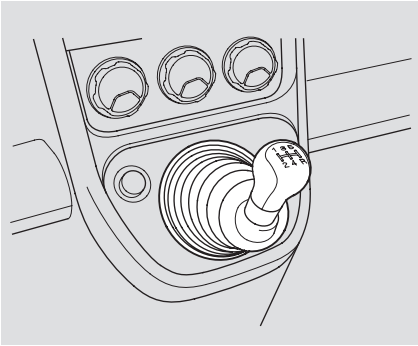

The manual transmission is synchronized in all forward gears for smooth operation. It has a lockout so you cannot shift directly from fifth to reverse. When shifting up or down, make sure you push the clutch pedal down all the way, shift to the next gear, and let the pedal up gradually. When you are not shifting, do not rest your foot on the clutch pedal. This can cause your clutch to wear out faster.

Come to a full stop before you shift into reverse. You can damage the transmission by trying to shift into reverse with the vehicle moving. Push down the clutch pedal, and pause for a few seconds before shifting into reverse, or shift into one of the forward gears for a moment. This stops the gears so they won't "grind."

When slowing down, you can get extra braking from the engine by shifting to a lower gear. This extra braking can help you maintain a safe speed and prevent your brakes from overheating while going down a steep hill. Before downshifting, make sure the engine speed will not go into the tachometer's red zone in the lower gear.

⚠ WARNING

Rapid slowing or speeding-up can cause loss of control on slippery surfaces. If you crash, you can be injured.

Use extra care when driving on slippery surfaces.

Manual Transmission

Recommended Shift Points

Drive in the highest gear that lets the engine run and accelerate smoothly. This will give you good fuel economy and effective emissions control. The following shift points are recommended:

Shift up	Normal acceleration
1st to 2nd	15 mph (24 km/h)
2nd to 3rd	25 mph (40 km/h)
3rd to 4th	40 mph (64 km/h)
4th to 5th	48 mph (77 km/h)

Engine Speed Limiter

If you exceed the maximum speed for the gear you are in, the engine speed will enter into the tachometer's red zone. If this occurs, you may feel the engine cut in and out. This is caused by a limiter in the engine's computer controls. The engine will run normally when you reduce the rpm below the red zone.

Before downshifting, make sure the engine will not go into the tachometer's red zone.

Shift Lever Position Indicators

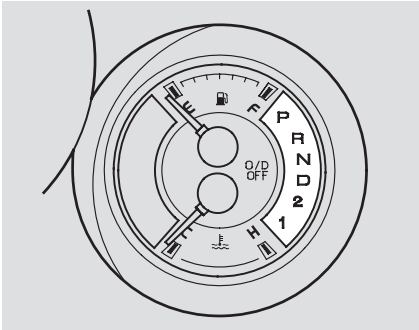

These indicators on the instrument panel show which position the shift lever is in. The “D” indicator comes on for a few seconds when you turn the ignition switch to the ON (II) position. If it flashes while driving (in any shift position), it indicates a possible problem in the transmission. Avoid rapid acceleration, and have the transmission checked by your dealer as soon as possible.

Shifting

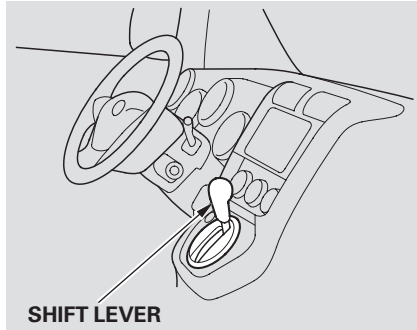

To shift from any position, press firmly on the brake pedal, push the release button, and pull the lever toward you. You cannot shift out of Park when the ignition switch is in the LOCK (0) or ACCESSORY (I) position.

To shift from:	Do this:
P to R	Press the brake pedal, and press the release button.
R to N N to D D to 2 2 to 1	Press the release button.
1 to 2 2 to D D to N N to R R to P	Move the lever.

Park (P) – This position mechanically locks the transmission. Use Park whenever you are turning off or starting the engine. To shift out of Park, you must press on the brake pedal and have your foot off the accelerator pedal.

If you have done all of the above and still cannot move the lever out of Park, see **Shift Lock Release** on page 146 .

CONTINUED

Automatic Transmission

To avoid transmission damage, come to a complete stop before shifting into Park. The shift lever must be in Park before you can remove the key from the ignition switch.

Reverse (R) – Press the brake pedal and press the release button to shift from Park to reverse. To shift from reverse to neutral, come to a complete stop, and then shift.

Your vehicle has a reverse lockout so you cannot accidentally shift to reverse when the vehicle speed exceeds 5 mph (8 km/h).

If you cannot shift to reverse when the vehicle is stopped, press the brake pedal and slowly shift to neutral. Then press the release button, and shift to reverse.

If there is a problem in the reverse lockout system, or your vehicle's battery is disconnected or goes dead, you cannot shift to reverse. (Refer to **Shift Lock Release** on page 146).

Neutral (N) – Use neutral if you need to restart a stalled engine, or if it is necessary to stop briefly with the engine idling. Shift to the Park position if you need to leave your vehicle for any reason. Press on the brake pedal when you are moving the shift lever from neutral to another gear.

Drive (D) – Use this position for your normal driving. The transmission automatically selects a suitable gear for the vehicle speed and acceleration. You may notice the transmission shifting up at higher speeds when the engine is cold. This helps the engine warm up faster.

Overdrive (O/D) Mode

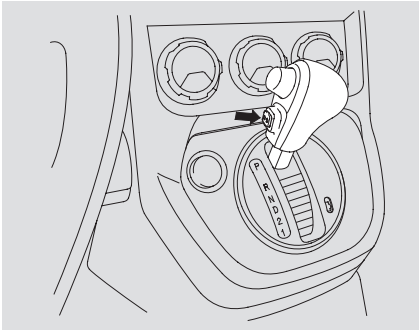

Overdrive (O/D) is on whenever you turn the ignition to ON (II). Press the O/D switch on the side of the shift lever to turn it off; the O/D OFF indicator comes on.

Overdrive can be turned on or off only when the ignition switch is in the ON (II) position.

When overdrive is off, the transmission selects only the first three gears. Use it to provide engine braking when going down a steep hill, or to keep the transmission from cycling between third and fourth gear in stop-and-go driving.

Second (2) — This position locks the transmission in second gear. It does not downshift to first gear when you come to a stop.

Use second gear:

- For more power when climbing.
- To increase engine braking when going down steep hills.
- For starting out on a slippery surface or in deep snow.
- To help reduce wheel spin.
- When driving downhill with a trailer.

First (1) — This position locks the transmission in first gear. By upshifting and downshifting through 1, 2, and D, you can operate this transmission much like a manual transmission without a clutch pedal.

If you shift into first when the vehicle speed is above 31 mph (50 km/h), the transmission shifts into second gear first to avoid sudden engine braking.

Engine Speed Limiter

If you exceed the maximum speed for the gear you are in, the engine speed will enter into the tachometer's red zone. If this occurs, you may feel the engine cut in and out. This is caused by a limiter in the engine's computer controls. The engine will run normally when you reduce the rpm below the red zone.

Automatic Transmission

Shift Lock Release

Do this if pushing on the brake pedal and pulling the shift lever does not shift the transmission out of Park:

1. Set the parking brake.
2. Make sure the ignition switch is in the LOCK (0) position.

To release the reverse lockout, make sure the ignition switch is in the ACCESSORY(I) position.

3. Put a cloth on the edge of the shift lock release slot cover next to the shift lever. Using a flathead screwdriver, carefully pry on the edge of the cover to remove it.

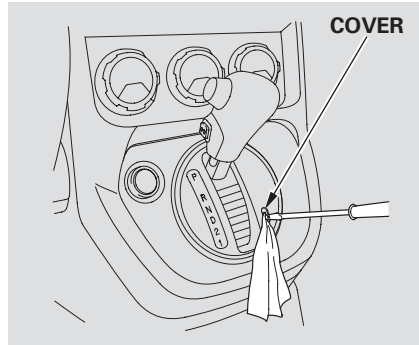

4. Insert the flat-tip screwdriver into the shift lock release slot.
5. Push down on the screwdriver while you press the release button and move the shift lever out of Park to neutral.

To release the reverse lockout, move the shift lever from neutral to reverse, then to Park.

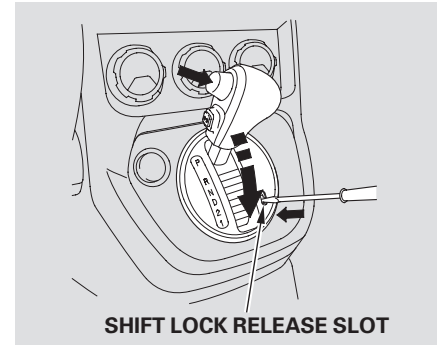

6. Remove the screwdriver from the shift lock release slot, then replace the cover. Make sure the notch on the cover is on the right side. Press the brake pedal and restart the engine.

If you need to use the shift lock release, it means your vehicle is developing a problem. Have it checked by your dealer.

Always use the parking brake when you park your vehicle. Make sure the parking brake is set firmly, or your vehicle may roll if it is parked on an incline.

If your vehicle has an automatic transmission, set the parking brake before you put the transmission in Park. This keeps the vehicle from moving and putting pressure on the parking mechanism in the transmission.

Parking Tips

- Make sure the windows are closed.
- Turn off the lights.
- Place any packages, valuables, etc. in the cargo area or take them with you.
- Lock the doors and the hatch with the key.
- Never park over dry leaves, tall grass, or other flammable materials. The hot three way catalytic converter could cause these materials to catch on fire.

- If the vehicle is facing uphill, turn the front wheels away from the curb. If you have a manual transmission, put it in first gear.
- If the vehicle is facing downhill, turn the front wheels toward the curb. If you have a manual transmission, put it in reverse gear.
- Make sure the parking brake is fully released before driving away. Driving with the parking brake partially set can overheat or damage the rear brakes.

Braking System

Your vehicle is equipped with disc brakes at all four wheels. A power assist helps reduce the effort needed on the brake pedal. The anti-lock brake system (ABS) helps you retain steering control when braking very hard.

Resting your foot on the pedal keeps the brakes applied lightly, builds up heat, and reduces their effectiveness. It also keeps your brake lights on all the time, confusing drivers behind you.

Constant application of the brakes when going down a long hill builds up heat and reduces their effectiveness. Use the engine to assist the brakes by taking your foot off the accelerator and downshifting to a lower gear.

Check the brakes after driving through deep water. Apply the brakes moderately to see if they feel normal. If not, apply them gently and frequently until they do. Be extra cautious in your driving.

Braking System Design

The hydraulic system that operates the brakes has two separate circuits. Each circuit works diagonally across the vehicle (the left-front brake is connected with the right-rear brake, etc.). If one circuit should develop a problem, you will still have braking at two wheels.

Brake Wear Indicators

If the brake pads need replacing, you will hear a distinctive, metallic screeching sound when you apply the brake pedal. If you do not have the brake pads replaced, they will screech all the time. It is normal for the brakes to occasionally squeal or squeak when you apply them.

Anti-lock Brakes

The anti-lock brake system (ABS) helps prevent the brakes from locking up, and helps you retain steering control by pumping the brakes rapidly, much faster than a person can do it.

The ABS also balances the front-to-rear braking distribution according to vehicle loading.

You should never pump the brake pedal.
Let the ABS work for you by always keeping firm, steady pressure on the brake pedal. This is sometimes referred to as “stomp and steer.”

You will feel a pulsation in the brake pedal when the ABS activates, and you may hear some noise. This is normal: it is the ABS rapidly pumping the brakes. On dry pavement, you will need to press on the brake pedal very hard before the ABS activates. However, you may feel the ABS activate immediately if you are trying to stop on snow or ice.

Anti-lock Brakes (ABS)



ABS Indicator

If this indicator comes on, the anti-lock function of the braking system has shut down. The brakes still work like a conventional system, but without anti-lock. You should have your dealer inspect your vehicle as soon as possible.

If the indicator comes on while driving, test the brakes as instructed on page 55 .

If the ABS indicator and the brake system indicator come on together and the parking break is fully released, the front-to-rear braking distribution system may also shut down.

Test your brakes as instructed on page 211 . If the brakes feel normal, drive slowly and have your vehicle repaired by your dealer as soon as possible. Avoid sudden hard braking which could cause the rear wheels to lock up and possibly lead to a loss of control.

Important Safety Reminders

ABS does not reduce the time or distance it takes to stop the vehicle. It only helps with steering control during braking.

ABS will not prevent a skid that results from changing direction abruptly, such as trying to take a corner too fast or making a sudden lane change.

ABS cannot prevent a loss of stability. Always steer moderately when you are braking hard. Severe or sharp steering wheel movement can still cause your vehicle to veer into oncoming traffic or off the road.

A vehicle with ABS may require a longer distance to stop on loose or uneven surfaces, such as gravel or snow, than a vehicle without anti-lock.

Your vehicle has been designed to primarily carry passengers and their cargo. You can also use it to tow a trailer if you carefully observe the load limits, use the proper equipment, and follow the guidelines in this section.

Be sure to read the *Driving Off-Highway Guidelines* section on page 157 if you plan to tow off paved surfaces.

⚠️ WARNING

Exceeding any load limit or improperly loading your vehicle and trailer can cause a crash in which you can be seriously hurt or killed.

Check the loading of your vehicle and trailer carefully before starting to drive.

Load Limits

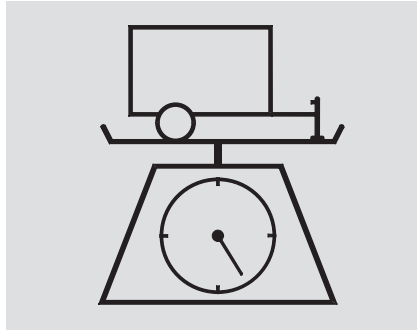

Total Trailer Weight: The maximum allowable weight of the trailer and everything in or on it must not exceed 1,500 lbs (680 kg). Towing a trailer that is too heavy can seriously affect your vehicle's handling and performance. It can also damage the engine and drivetrain.

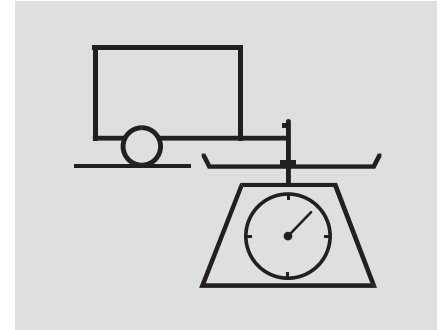

Tongue Load: The weight that the tongue of a fully-loaded trailer puts on the hitch should be approximately 10 % of the total trailer weight. Too much tongue load reduces front-tire traction and steering control. Too little tongue load can make the trailer unstable and cause it to sway.

CONTINUED

Towing a Trailer

To achieve a proper tongue load, start by loading 60 % of the load toward the front of the trailer and 40 % toward the rear, then re-adjust the load as needed.

- **Gross Vehicle Weight Rating (GVWR):**

The maximum allowable weight of the vehicle, all occupants, all cargo, and tongue load is:

4,450 lbs (2,020 kg)

- **Gross Axle Weight Rating (GAWR):**

The maximum allowable weight of the vehicle axles is:

2,300 lbs (1,045 kg)

on the front axle

2,205 lbs (1,000 kg)

on the rear axle

Checking Loads

The best way to confirm that vehicle and trailer weights are within limits is to have them checked at a public scale.

Using a suitable scale or a special tongue load gauge, check the tongue load the first time you set up a towing combination (a fully-loaded vehicle and trailer), then recheck the tongue load whenever the conditions change.

Towing Equipment and Accessories

Towing can require a variety of equipment, depending on the size of your trailer, how it will be used, how much load you are towing, and where you tow. To ensure the highest quality equipment, purchase Honda equipment whenever possible.

Discuss your needs with your trailer sales or rental agency, and follow the guidelines in the rest of this section. Also make sure that all equipment is properly installed and that it meets federal, state, province, and local regulations.

Hitches

Any hitch used on your vehicle must be properly bolted to the underbody.

Safety Chains

Always use safety chains when you tow a trailer. Make sure the chains are secured to the trailer and hitch, and that they cross under the tongue and can catch the trailer if it becomes unhitched. Leave enough slack to allow the trailer to turn corners easily, but do not let the chains drag on the ground.

Trailer Brakes

Honda recommends that any trailer having a total weight of 1,000 lbs (450 kg) or more be equipped with its own electric or surge-type brakes.

If you choose electric brakes, be sure they are electrically actuated. Do not attempt to tap into your vehicle's hydraulic system. No matter how successful it may seem, any attempt to attach trailer brakes to your vehicle's hydraulic system will lower braking effectiveness and create a potential hazard.

See your trailer dealer for more information on installing electric brakes.

CONTINUED

Towing a Trailer

Trailer Lights

Trailer lights and equipment must comply with federal, state, and local regulations. Check with your trailer sales or rental agency for the requirements in your area, and use only equipment designed for your vehicle.

Since lighting and wiring vary by trailer type and brand, you should have a qualified technician install a suitable connector between the vehicle and the trailer. Improper equipment or installation can cause damage to your vehicle's electrical system and affect your vehicle warranty.

Additional Towing Equipment

Many states and Canadian provinces require special outside mirrors when towing a trailer. Even if they don't, you should install special mirrors if you cannot clearly see behind you, or if the trailer creates a blind spot.

Ask your trailer sales or rental agency if any other items are recommended or required for your towing situation.

Pre-Tow Checklist

When preparing to tow, and before driving away, be sure to check the following:

- The vehicle has been properly serviced, and the tires, brakes, suspension, cooling system, and lights are in good operating condition.
 - The trailer has been properly serviced and is in good condition.
 - All weights and loads are within limits (see pages [151](#) and [152](#)).
 - The hitch, safety chains, and any other attachments are secure.
 - All items in or on the trailer are properly secured and cannot shift while you drive.
- Your vehicle tires and spare are properly inflated (see page [187](#)), and the trailer tires and spare are inflated as recommended by the trailer maker.

Driving Safely With a Trailer

The added weight, length, and height of a trailer will affect your vehicle's handling and performance, so driving with a trailer requires some special driving skills and techniques.

For your safety and the safety of others, take time to practice driving maneuvers before heading for the open road, and follow the guidelines below.

Towing Speeds and Gears

Drive slower than normal in all driving situations, and obey posted speed limits for vehicles with trailers. If you have an automatic transmission, use overdrive (O/D) when towing a trailer on level roads. Turn off the overdrive (O/D) when towing a trailer in hilly terrain.

CONTINUED

Towing a Trailer

Making Turns and Braking

Make turns more slowly and wider than normal. The trailer tracks a smaller arc than your vehicle, and it can hit or run over something the vehicle misses. Allow more time and distance for braking. Do not brake or turn suddenly as this could cause the trailer to jackknife or turn over.

Driving on Hills

When climbing hills, closely watch your temperature gauge. If it nears the red (Hot) mark, turn the air conditioning off, reduce speed and, if necessary, pull to the side of the road to let the engine cool.

If the automatic transmission shifts frequently between 3rd and 4th gears while going up a hill, turn off the overdrive (O/D) (see page 145).

If you must stop when facing uphill, use the foot brake or parking brake. Do not try to hold the vehicle in place by pressing on the accelerator, as this can cause the automatic transmission to overheat.

When driving down hills, reduce your speed and shift down to 3rd gear (manual transmission) or turn off the overdrive (O/D) (automatic transmission). Do not “ride” the brakes, and remember it will take longer to slow down and stop when towing a trailer.

Handling Crosswinds and Buffeting

Crosswinds and air turbulence caused by passing trucks can disrupt your steering and cause trailer to sway. When being passed by a large vehicle, keep a constant speed, and steer straight ahead. Do not try to make quick steering or braking corrections.

Backing Up

Always drive slowly and have someone guide you when backing up. Grip the *bottom* of the steering wheel; then turn the wheel to the left to get the trailer to move to the left, and turn the wheel right to move the trailer to the right.

Parking

Follow all normal precautions when parking, including firmly setting the parking brake and putting the transmission in Park (automatic) or in 1st or reverse (manual). Also, place wheel chocks at each of the trailer’s tires.

General Information

Your vehicle has been designed primarily for use on pavement. But its higher ground clearance allows you to occasionally travel on unpaved roads, to campgrounds, picnic sites, and similar locations. It is not designed for trail-blazing, mountain climbing, or other challenging off-road activities.

If you decide to drive on unpaved roads, you will find that it requires somewhat different driving skills. Your vehicle will also handle somewhat differently than it does on pavement. So be sure to read this owner's manual, pay special attention to the precautions and tips in this section, and get acquainted with your vehicle before you leave the pavement.

WARNING

Improperly operating this vehicle on or off-pavement can cause an accident or rollover in which you and your passengers could be seriously injured or killed.

- Follow all instructions and guidelines in this owner's manual.
- Keep your speed low, and don't drive faster than conditions permit.

Important Safety Precautions

To avoid loss of control or rollover, be sure to follow all precautions and recommendations.

- Be sure to store cargo properly, and do not exceed your vehicle cargo load limits (see pages [133](#) and [151](#)).
- Wherever you drive, make sure you and your passengers always wear seat belts.
- Keep your speed low, and never go faster than the conditions allow.
- It's up to you to continually assess the situation and drive within the limits.

Off-Highway Driving Guidelines

Check Out Your Vehicle

Before you leave the pavement, be sure to do all scheduled maintenance and service, and inspect your vehicle for any problems. Pay special attention to the condition of the tires, and check the tire pressures.

After you return to the pavement, carefully inspect your vehicle to make sure there is no damage that could make driving it unsafe. Recheck the condition of the tires and the tire pressures.

Remember

The route presents limits (too steep or bumpy roads). You have limits (driving skill and comfort). And your vehicle has limits (traction, stability, and power).

Driving off-highway can be hazardous if you fail to recognize limits and take the proper precautions.

Accelerating and Braking

For better traction on all surfaces, accelerate slowly and gradually build up speed. If you try to start too fast on wet soil, mud, snow, or ice, you might not have enough traction to get underway, and you may dig yourself a hole. Starting with the shift lever in second (2) gear will help you have a smoother start on snow or ice.

Keep in mind that you will usually need more time and distance to brake to a stop on unpaved surfaces. Avoid hard braking. Do not “pump” the brakes; let the anti-lock braking system pump them for you.

Avoiding Obstacles

Debris in the road can damage your suspension or other components. Because your vehicle has a high center of gravity, driving over a large obstacle, or allowing a wheel to drop into a deep hole can cause your vehicle to tip or roll over.

Driving on Slopes

If you can't clearly see all conditions or obstacles on a slope, walk the slope before you drive on it. If you have any doubt whether or not you can safely drive on the slope, don't do it. Find another route.

If you are driving up a hill and find that you cannot continue, *do not try to turn around*. Your vehicle could roll over. Slowly back down the hill, following the same route you took up the hill.

Crossing a Stream

Avoid driving through deep water. If you encounter water in your route (a small stream or large puddle, for example), evaluate it carefully before going ahead. Make sure it is shallow, flowing slowly, and has firm ground underneath. If you are not sure of the depth or the ground, turn around and find another route.

Driving through deep water can also damage your vehicle. The water can get into the transmission and differential, diluting the lubricant and causing an eventual failure. It can also wash the grease out of the wheel bearings.

If You Get Stuck

Avoid driving on soft sand, deep mud, or other surfaces where you could get stuck. If you do happen to get stuck because of inclement weather or other conditions, choose a safe and appropriate course of action.

You should never use a jack to try getting unstuck. A jack only works on firm, level ground. Also, your vehicle could easily slip off the jack and hurt you or someone else.

4-Wheel Drive Vehicles

If you spin the wheels excessively trying to get unstuck, you may overheat the components of the 4-wheel drive system. If this happens, the 4-wheel drive system shuts off and only the front wheels receive power. If this happens, stop and allow everything to cool down. The 4-wheel drive system will work again after its temperature drops.

If you slip the clutch for a long time while trying to get unstuck, you may overheat and damage it.

This section explains why it is important to keep your vehicle well maintained and how to follow basic maintenance safety precautions.

This section also includes maintenance schedules for normal driving and severe driving conditions, a maintenance record, and instructions for simple maintenance tasks you may want to take care of yourself.

If you have the skills and tools to perform more complex maintenance tasks on your vehicle, you may want to purchase the service manual. See page [237](#) for information on how to obtain a copy, or see your dealer.

Maintenance Safety.....	162
Maintenance Schedule.....	163
Maintenance Record.....	167
Fluid Locations.....	169
Adding Engine Oil.....	170
Changing the Oil and Filter.....	171
Engine Coolant.....	173
Windshield Washers.....	174
Automatic Transmission Fluid.....	175
Manual Transmission Fluid.....	176
Brake and Clutch Fluid.....	177
Power Steering Fluid.....	178
Cleaning the Body Panels.....	178
Lights.....	179
Cleaning the Seat Belts.....	185
Dust and Pollen Filter.....	185
Wiper Blades.....	186
Tires.....	187
Checking the Battery.....	193
Vehicle Storage.....	194

Maintenance Safety

All service items not detailed in this section should be performed by a certified technician or other qualified mechanic.

Important Safety Precautions

To eliminate potential hazards, read the instructions before you begin, and make sure you have the tools and skills required.

- Make sure your vehicle is parked on level ground, the parking brake is set, and the engine is off.
- To clean parts, use a commercially available degreaser or parts cleaner, not gasoline.
- To reduce the possibility of fire or explosion, keep cigarettes, sparks, and flames away from the battery and all fuel-related parts.
- Wear eye protection and protective clothing when working

with the battery or compressed air.

WARNING

Improperly maintaining this vehicle or failing to correct a problem before driving can cause a crash in which you can be seriously hurt or killed.

Always follow the inspection and maintenance recommendations, and schedules in this owner's manual.

Potential Vehicle Hazards

- **Carbon Monoxide poison from engine exhaust.** Be sure there is adequate ventilation whenever you operate the engine.
- **Burns from hot parts.** Let the engine and exhaust system cool down before touching any parts.

- **Injury from moving parts.** Do not run the engine unless instructed to do so.

WARNING

Failure to properly follow maintenance instructions and precautions can cause you to be seriously hurt or killed.

Always follow the procedures and precautions in this owner's manual.

Some of the most important safety precautions are given here. However, we cannot warn you of every conceivable hazard that can arise in performing maintenance. Only you can decide whether or not you should perform a given task.

The maintenance schedule assumes you will use your vehicle as normal transportation for passengers and their possessions. You should also follow these recommendations:

- Avoid exceeding your vehicle's load limit. This puts excess stress on the engine, brakes, and many other vehicle parts. The load limit is shown on the tire information label on the driver's doorjamb.
- Operate your vehicle on reasonable roads within the legal speed limit.
- Drive your vehicle regularly over a distance of several miles (kilometers).
- Always use unleaded gasoline with the proper octane rating (see page [124](#)).

Which Schedule to Follow

Service your vehicle according to the time and mileage periods on one of the maintenance schedules on the following pages.

U.S. Owners — Follow the maintenance schedule for severe conditions if you drive your vehicle **MAINLY** under one or more of the following conditions.

- Driving less than 5 miles (8 km) per trip, or in freezing temperatures, driving less than 10 miles (16 km) per trip.
- Driving in extremely hot [over 90°F (32°C)] conditions.
- Used primarily as a delivery vehicle or taxi that is driven mostly in stop-and-go traffic and/or parked with the engine idling.

- Trailer towing, driving with a loaded roof rack, or driving in mountainous conditions.
- Driving on muddy, dusty, or de-iced roads.

NOTE: If you only *OCCASIONALLY* drive under a “severe” condition, you should follow the normal conditions maintenance schedule.

Canadian Owners — Follow the maintenance schedule for severe conditions.

Maintenance Schedule

Servicing Your Vehicle

Your authorized dealer knows your vehicle best and can provide competent, efficient service.

However, service at a dealer is not mandatory to keep your warranties in effect. Maintenance may be done by any qualified service facility or skilled person to keep your warranties in effect. Keep all the receipts as proof of completion, and have the person who does the work fill out the maintenance record. Check your warranty booklet for more information.

We recommend the use of Honda parts and fluids whenever you have maintenance done.

U.S. Vehicles:

Maintenance, replacement, or repair of emissions control devices and systems may be done by any automotive repair establishment or individual using parts that are “certified” to EPA standards.

According to state and federal regulations, failure to perform maintenance on the items marked with # will not void your emissions warranties. However, all maintenance services should be performed at the recommended time or mileage period to ensure long-term reliability.

Owner’s Maintenance Checks

You should check the following items at the specified intervals. If you are unsure of how to perform any check, turn to the appropriate page listed.

- Engine oil level — Check every time you fill the fuel tank. See page [128](#).
- Engine coolant level — Check the radiator reserve tank every time you fill the fuel tank. See page [128](#).
- Automatic transmission — Check the fluid level monthly. See page [175](#).
- Brakes — Check the fluid level monthly. See page [177](#).
- Tires — Check the tire pressure monthly. Examine the tread for wear and foreign objects. See page [188](#).
- Lights — Check the operation of the headlights, parking lights, taillights, high-mount brake light, and license plate lights monthly. See page [179](#).

Service the items listed at the indicated distance (or time, if given).																	
	miles x 1,000	10	20	30	40	50	60	70	80	90	100	110	120	130	140	150	
	km x 1,000	16	32	48	64	80	96	112	128	144	160	176	192	208	224	240	
Check engine oil and coolant		Check oil and coolant at each fuel stop															
Check tires		Check inflation and condition once a month															
Replace engine oil		•	•	•	•	•	•	•	•	•	•	•	•	•	•	•	•
		<i>(Or every 1 year, whichever comes first)</i>															
Rotate tires (follow pattern on page 190)		Every 10,000 miles (16,000 km)															
Replace engine oil filter																	
Check front and rear brakes																	
Check parking brake adjustment																	
Inspect the following items:																	
Tie-rod ends, steering gearbox, and boots																	
Suspension components			•		•		•		•		•		•		•		•
Driveshaft boots																	
Brake hoses and lines (including ABS)																	
All fluid levels and condition of fluids																	
Exhaust system [‡]																	
Fuel lines and connections [‡]																	
Inspect drive belts				•			•			•			•				•
Replace dust and pollen filter																	
Replace air cleaner element			•				•			•			•				•
Replace spark plugs													•				
Inspect valve clearance													•				
Replace automatic transmission fluid* ¹																	•
Replace manual transmission fluid																	
Replace rear differential fluid																	
Inspect idle speed																	
Replace engine coolant																	
Replace brake fluid																	

* 1: Replace at 120,000 miles (192,000 km) or 6 years, then every 90,000 miles (144,000 km) or 5 years.

: See information on maintenance and emissions warranty on page 164.

Follow the normal maintenance schedule if the severe driving conditions maintenance schedule on the next page do not apply.

NOTE: If you only OCCASIONALLY drive under a “severe” condition, you should follow the normal conditions maintenance schedule.

Service the items listed at the indicated distance (or time, if given).																
	miles x 1,000	10	20	30	40	50	60	70	80	90	100	110	120	130	140	150
	km x 1,000	16	32	48	64	80	96	112	128	144	160	176	192	208	224	240
Check engine oil and coolant	Check oil and coolant at each fuel stop															
Check tires	Check inflation and condition once a month															
Replace engine oil	Every 5,000 miles (8,000 km) or every 6 months, whichever comes first															
Rotate tires (follow pattern on page 190)	Every 10,000 miles (16,000 km)															
Replace engine oil filter																
Check front and rear brakes																
Lubricate all hinges, locks and latches		•	•	•	•	•	•	•	•	•	•	•	•	•	•	•
Inspect the following items: Tie rod ends, steering gearbox, and boots Suspension components, driveshaft boots																
Check parking brake adjustment																
Inspect the following items: Brake hoses and lines (including ABS) All fluid levels and condition of fluids Exhaust system [‡] , fuel lines and connections [‡] Lights and controls/vehicle underbody		•		•		•		•		•		•		•		•
Inspect drive belts			•				•				•			•		•
Replace dust and pollen filter*1																
Replace air cleaner element																
Replace spark plugs																
Inspect valve clearance																
Replace automatic transmission fluid*2																
Replace manual transmission fluid																
Replace rear differential fluid																
Inspect idle speed																
Replace engine coolant																
Replace brake fluid																

Follow the severe maintenance schedule if you drive your vehicle MAINLY under one or more of the following conditions:

- Driving less than 5 miles (8 km) per trip or, in freezing temperatures, driving less than 10 miles (16 km) per trip.
- Driving in extremely hot [over 90°F (32°C)] conditions.
- Extensive idling or long periods of stop and go driving, such as a taxi or a commercial delivery vehicle.
- Trailer towing, driving with a loaded roof rack, or driving in mountainous conditions.
- Driving on muddy, dusty, or de-iced roads.

Canadian Owners — Follow the maintenance schedule for severe conditions.

*1 : See dust and pollen filter on page 185 for replacement information under special driving conditions.

*2 : Replace at 60,000 miles (96,000 km) or 3 years, then every 30,000 miles (48,000 km) or 2 years.

: See information on maintenance and emissions warranty on page 164 .

Maintenance Record *(for Normal and Severe Schedules)*

You or the servicing dealer can record all completed maintenance here, whether you follow the schedule for normal conditions (page 165) or severe conditions (page 166). Keep the receipts for all work done on your vehicle. Maintenance can also be recorded in your Honda service history booklet.

5,000 mi 8,000 km	Signature or dealer stamp	mi/km
		Date
10,000 mi 16,000 km		mi/km
		Date
15,000 mi 24,000 km		mi/km
		Date
20,000 mi 32,000 km (or 1 year)		mi/km
		Date
25,000 mi 40,000 km		mi/km
		Date
30,000 mi 48,000 km		mi/km
		Date
35,000 mi 56,000 km		mi/km
		Date
40,000 mi 64,000 km (or 2 years)		mi/km
		Date

45,000 mi 72,000 km	Signature or dealer stamp	mi/km
		Date
50,000 mi 80,000 km		mi/km
		Date
55,000 mi 88,000 km		mi/km
		Date
60,000 mi 96,000 km (or 3 years)		mi/km
		Date
65,000 mi 104,000 km		mi/km
		Date
70,000 mi 112,000 km		mi/km
		Date
75,000 mi 120,000 km		mi/km
		Date
80,000 mi 128,000 km (or 4 years)		mi/km
		Date

Maintenance Record *(for Normal and Severe Schedules)*

85,000 mi 136,000 km	Signature or dealer stamp	mi/km
		Date
90,000 mi 144,000 km		mi/km
		Date
95,000 mi 152,000 km		mi/km
		Date
100,000 mi 160,000 km (or 5 years)		mi/km
		Date
105,000 mi 168,000 km		mi/km
		Date
110,000 mi 176,000 km		mi/km
		Date
115,000 mi 184,000 km		mi/km
		Date
120,000 mi 192,000 km (or 6 years)		mi/km
		Date

125,000 mi 200,000 km	Signature or dealer stamp	mi/km
		Date
130,000 mi 208,000 km		mi/km
		Date
135,000 mi 216,000 km		mi/km
		Date
140,000 mi 224,000 km (or 7 years)		mi/km
		Date
145,000 mi 232,000 km		mi/km
		Date
150,000 mi 240,000 km		mi/km
		Date
155,000 mi 248,000 km		mi/km
		Date
160,000 mi 256,000 km (or 8 years)		mi/km
		Date

Fluid Locations

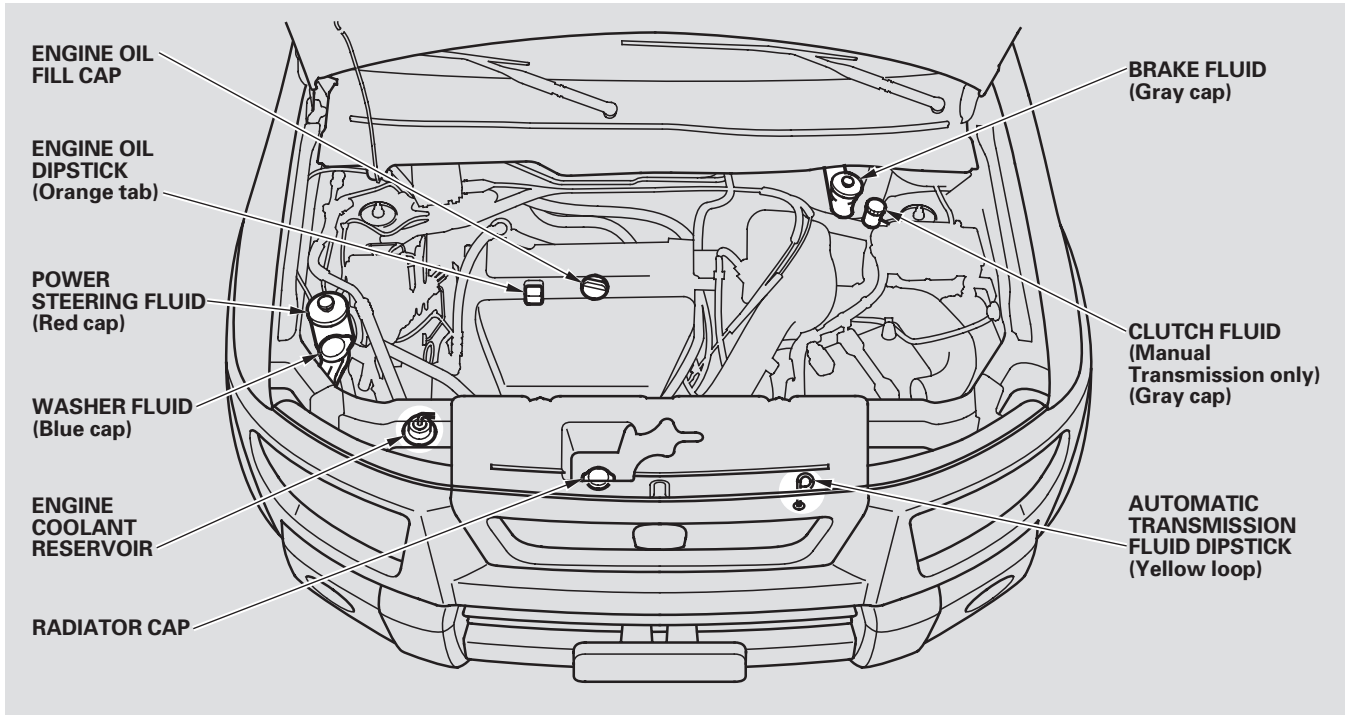

Adding Engine Oil

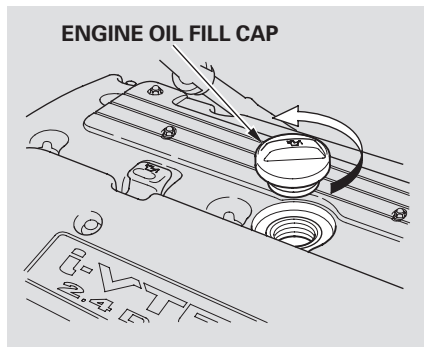

Unscrew and remove the engine oil fill cap on top of the valve cover. Pour in the oil slowly and carefully so you do not spill. Clean up any spills immediately. Spilled oil could damage components in the engine compartment. Install the engine oil fill cap, and tighten it securely. Wait a few minutes, and recheck the oil level. Do not fill above the upper mark; you could damage the engine.

Recommended Engine Oil

Oil is a major contributor to your engine's performance and longevity. Always use a premium-grade 5W-20 detergent oil displaying the API certification seal. This seal indicates the oil is energy conserving, and that it meets the American Petroleum Institute's latest requirements.



Honda motor oil is the preferred 5W-20 lubricant for your vehicle. It is highly recommended that you use Honda motor oil in your vehicle for optimum engine protection. Make sure the API certification seal says "For Gasoline Engines."

The oil viscosity or weight is provided on the container's label. 5W-20 oil is formulated for year-round protection of your vehicle to improve cold weather starting and fuel economy.

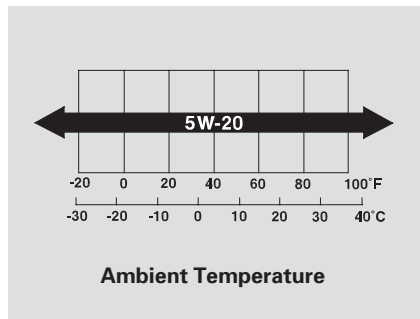

Adding Engine Oil, Changing the Oil and Filter

Synthetic Oil

You may use a synthetic motor oil if it meets the same requirements given for a conventional motor oil: it displays the API certification seal, and it is the proper weight. You must follow the oil and filter change intervals given on the maintenance schedule.

Engine Oil Additives

Your vehicle does not require any oil additives. Additives may adversely affect the engine or transmission performance and durability.

Changing the Oil and Filter

Always change the oil and filter according to the recommendations in the maintenance schedule. The oil and filter collect contaminants that can damage your engine if they are not removed regularly.

Changing the oil and filter requires special tools and access from underneath the vehicle. The vehicle should be raised on a service station-type hydraulic lift for this service. Unless you have the knowledge and proper equipment, you should have this maintenance done by a skilled mechanic.

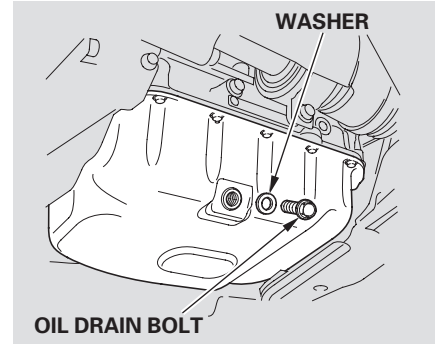

1. Run the engine until it reaches normal operating temperature, then shut it off.
2. Open the hood, and remove the engine oil fill cap. Remove the oil drain bolt and washer from the bottom of the engine. Drain the oil into an appropriate container.

CONTINUED

Changing the Oil and Filter

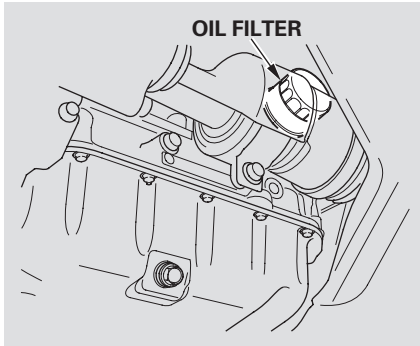

3. Remove the oil filter and let the remaining oil drain. A special wrench (available from your dealer) is required.

Make sure the oil filter gasket is not stuck to the engine block. If it is, remove it before installing a new oil filter.

4. Install a new oil filter according to the instructions that come with it.
5. Put a new washer on the drain bolt, then reinstall the drain bolt.
Tighten the drain bolt to:
33 lbf-ft (44 N·m , 4.5 kgf·m)
6. Refill the engine with the recommended oil.

Engine oil change capacity
(including filter):
4.4 US qt (4.2 ℓ)

7. Replace the engine oil fill cap.
Start the engine. The oil pressure indicator should go out within 5 seconds. If it does not, turn off the engine, and check your work.
8. Let the engine run for several minutes, then check the drain bolt and oil filter for leaks.

9. Turn off the engine and let it sit for several minutes, then check the oil level on the dipstick. If necessary, add more oil.

NOTICE

Improper disposal of engine oil can be harmful to the environment. If you change your own oil, please dispose of the used oil properly. Put it in a sealed container, and take it to a recycling center. Do not discard it in a trash bin or dump it on the ground.

Adding Engine Coolant

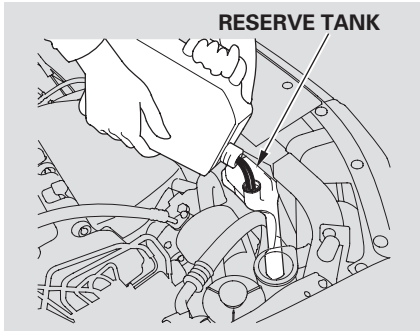

If the coolant level in the reserve tank is at or below the MIN line, add coolant to bring it up to between the MIN and MAX lines. Inspect the cooling system for leaks.

Always use Honda Long-life Antifreeze/Coolant Type 2. This coolant is pre-mixed with 50 percent antifreeze and 50 percent water. Never add straight antifreeze or plain water.

If Honda antifreeze/coolant is not available, you may use another major-brand non-silicate coolant as a temporary replacement. Make sure it is a high-quality coolant recommended for aluminum engines. Continued use of any non-Honda coolant can result in corrosion, causing the cooling system to malfunction or fail. Have the cooling system flushed and refilled with Honda antifreeze/coolant as soon as possible.

If the reserve tank is completely empty, you should also check the coolant level in the radiator.

⚠ WARNING

Removing the radiator cap while the engine is hot can cause the coolant to spray out, seriously scalding you.

Always let the engine and radiator cool down before removing the radiator cap.

CONTINUED

Engine Coolant, Windshield Washers

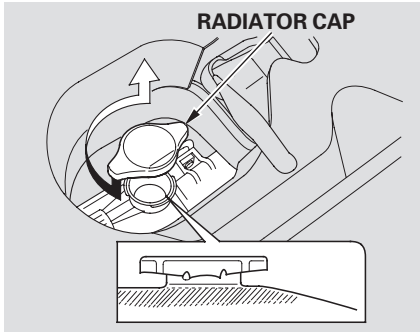

1. When the radiator and engine are cool, relieve any pressure in the cooling system by turning the radiator cap counterclockwise, without pressing down.
2. Remove the radiator cap by pushing down and turning counterclockwise.

3. The coolant level should be up to the base of the filler neck. Add coolant if it is low.

Pour the coolant slowly and carefully so you do not spill any. Clean up any spill immediately; it could damage components in the engine compartment.

4. Put the radiator cap back on and tighten it.
5. Pour coolant into the reserve tank. Fill it to halfway between the MAX and MIN marks. Put the cap back on the reserve tank.

Do not add any rust inhibitors or other additives to your vehicle's cooling system. They may not be compatible with the coolant or engine components.

Windshield Washers

Check the fluid level in the windshield washer reservoir at least monthly during normal use.

On Canadian models: The low washer level indicator comes on when the level is low (see page 57).

Fill the reservoir with a good-quality windshield washer fluid. This increases the cleaning capability and prevents freezing in cold weather. When you refill the reservoir, clean the edges of the windshield wiper blades with windshield washer fluid on a clean cloth. This will help to condition them.

NOTICE

Do not use engine antifreeze or a vinegar/water solution in the windshield washer reservoir. Antifreeze can damage your vehicle's paint, while a vinegar/water solution can damage the windshield washer pump. Use only commercially-available windshield washer fluid.

Automatic Transmission Fluid

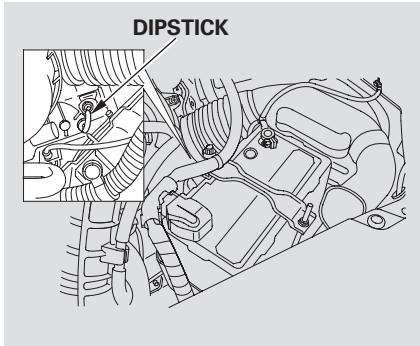

Check the fluid level with the engine at normal operating temperature.

1. Park the vehicle on level ground. Shut off the engine.
2. Remove the dipstick (yellow loop) from the transmission, and wipe it with a clean cloth.
3. Insert the dipstick all the way into the transmission securely.

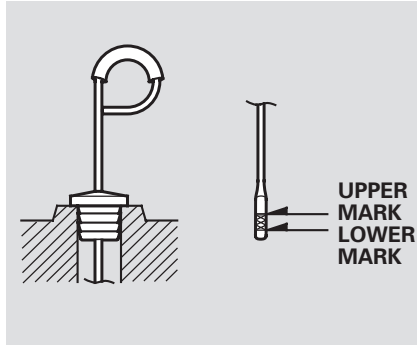

4. Remove the dipstick and check the fluid level. It should be between the upper and lower marks.
5. If the level is below the lower mark, add fluid into the filler hole to bring it to the upper mark. Pour the fluid slowly and carefully so you do not spill any. Clean up any spill immediately; it could damage components in the engine compartment.

Always use Honda ATF-Z1 (automatic transmission fluid). If it's not available, you may use a DEXRON® III automatic transmission fluid as a temporary replacement. However, continued use can affect the shift quality. Have the transmission flushed and refilled with Honda ATF-Z1 as soon as it is convenient.

6. Insert the dipstick all the way back in the transmission.

The transmission should be drained and refilled with new fluid according to the time and distance recommendations in the maintenance schedule. If you are not sure how to add fluid, contact your dealer.

Manual Transmission Fluid

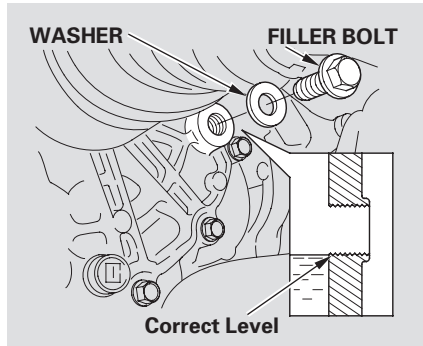

Check the fluid level with the transmission at normal operating temperature and the vehicle sitting on level ground. Remove the transmission filler bolt, and carefully feel inside the bolt hole with your finger. The fluid level should be up to the edge of the bolt hole. If it is not, add Honda manual transmission fluid (MTF) until it starts to run out of the hole. Reinstall the filler bolt, and tighten it securely.

If Honda MTF is not available, you may use an SAE 10W-30 or 10W-40 viscosity motor oil with the API Certification seal that says “FOR GASOLINE ENGINES” as a temporary replacement. However, motor oil does not contain the proper additives, and continued use can cause stiffer shifting. Replace as soon as it is convenient.

The transmission should be drained and refilled with new fluid according to the time and distance recommendations in the maintenance schedule.

Check the brake fluid level in the reservoirs monthly.

Replace the brake fluid according to the time recommendation in the maintenance schedule.

Always use Honda Heavy Duty Brake Fluid DOT 3. If it is not available, you should use only DOT 3 or DOT 4 fluid, from a sealed container, as a temporary replacement.

Using any non-Honda brake fluid can cause corrosion and decrease the life of the system. Have the brake system flushed and refilled with Honda Heavy Duty Brake Fluid DOT 3 as soon as possible.

Brake fluid marked DOT 5 is not compatible with your vehicle's braking system and can cause extensive damage.

Brake Fluid

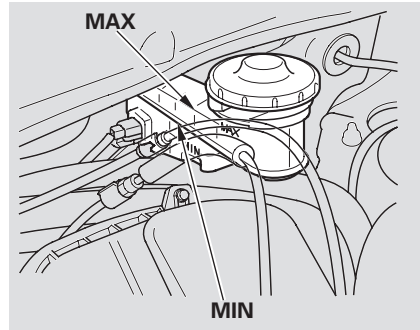

The fluid level should be between the MIN and MAX marks on the side of the reservoir. If the level is at or below the MIN mark, your brake system needs attention. Have the brake system inspected for leaks or worn brake pads.

Clutch Fluid

Manual Transmission only

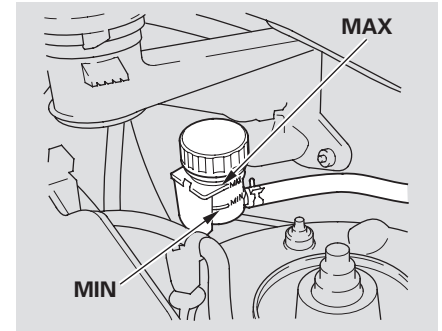

The fluid level should be between the MIN and MAX marks on the side of the reservoir. If it is not, add brake fluid to bring it up to that level. Use the same fluid specified for the brake system.

Low fluid can indicate a leak in the clutch system. Have this system inspected as soon as possible.

Power Steering Fluid, Cleaning the Body Panels

Power Steering Fluid

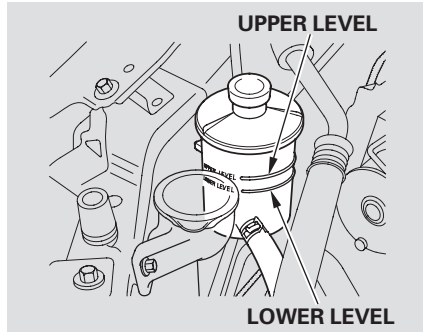

Check the level on the side of the reservoir when the engine is cold. The fluid should be between the UPPER LEVEL and LOWER LEVEL. If not, add power steering fluid to the UPPER LEVEL.

Pour the fluid slowly and carefully so you do not spill any. Clean up any spill immediately; it could damage components in the engine compartment.

Always use Honda Power Steering Fluid. You may use another power steering fluid as an emergency replacement, but have the power steering system flushed and refilled with Honda PSF as soon as possible.

A low power steering fluid level can indicate a leak in the system. Check the fluid level frequently, and have the system inspected as soon as possible.

NOTICE

Turning the steering wheel to full left or right lock and holding it there can damage the power steering pump.

Cleaning the Body Panels

If equipped with body panels

To clean the gray composite body panels, wash them with soap and water only. Do not apply wax to the panels; it will cause discoloration.

Headlight Aiming

The headlights were properly aimed when your vehicle was new. If you regularly carry heavy items in the cargo area or pull a trailer, readjustment may be required. Adjustments should be done by your dealer or other qualified mechanic.

Replacing a Headlight Bulb

Your vehicle has halogen headlight bulbs. Handle it by its steel base and protect the glass from contact with your skin or hard objects. If you touch the glass, clean it with denatured alcohol and a clean cloth.

NOTICE

Halogen headlight bulbs get very hot when lit. Oil, perspiration, or a scratch on the glass can cause the bulb to overheat and shatter.

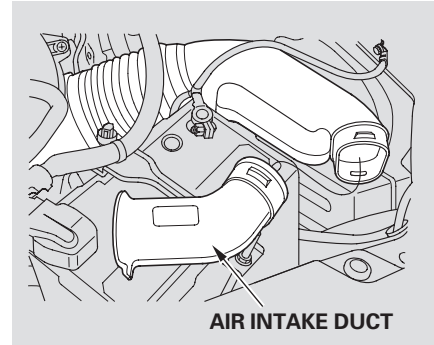

1. Open the hood.
If you need to change the headlight bulb on the driver's side, remove the front end of the air intake duct by pulling it out.

CONTINUED

Lights

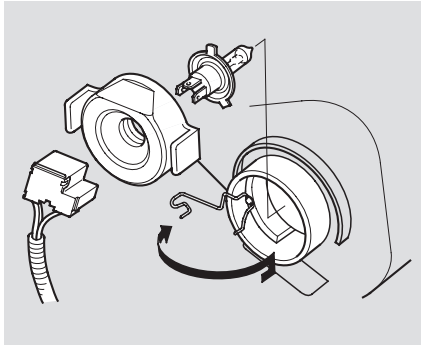

2. Remove the electrical connector from the bulb by pulling the connector straight back.
3. Remove the rubber weather seal by pulling on the tab.
4. Unclip the end of the hold-down wire from its slot. Pivot it out of the way, and remove the bulb.

5. Insert the new bulb into the hole, making sure the tabs are in their slots. Pivot the hold-down wire back in place, and clip the end into the slot.
6. Reinstall the rubber weather seal. Make sure it is right side up; it is marked "TOP."
7. Push the electrical connector onto the new bulb.
8. (Driver's side)
Install the front end of the air intake duct.

Replacing a Front Parking/Turn Signal Light Bulb

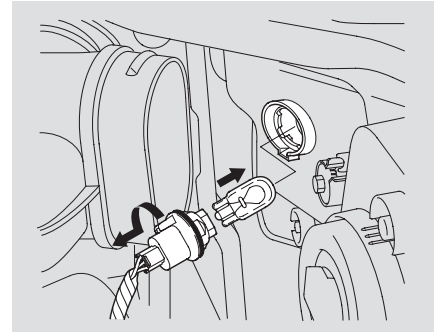

1. The front parking/turn signal light is next to the headlight bulb. On the driver's side, remove the front end of the air intake duct by pulling it out (see page [179](#)).
2. Remove the socket from the headlight assembly by turning it one-quarter turn counterclockwise.

3. Pull the bulb straight out of its socket. Push the new bulb straight into the socket until it bottoms.
4. Insert the socket back into the headlight assembly. Turn it clockwise to lock it in place.
5. Test the lights to make sure the new bulb is working.
6. (Driver's side)
Install the front end of the air intake duct.

Replacing a Front Side Marker Light Bulb

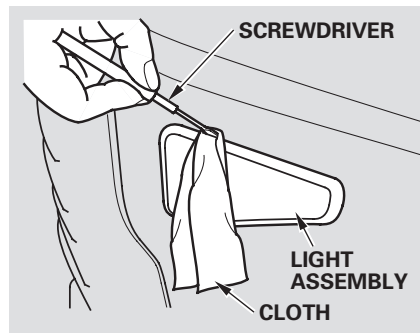

1. Place a cloth between the trim of the lens and the body, at the top of the lens. Remove the front side marker light assembly by carefully prying on the trim of the lens with a small flat-tip screwdriver.

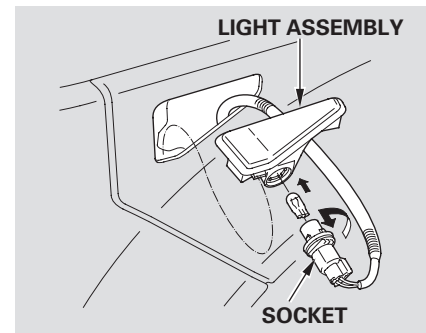

2. Remove the socket from the light assembly by turning it one-quarter turn counterclockwise.
3. Pull the bulb straight out of its socket. Push the new bulb straight into the socket until it bottoms.

CONTINUED

Lights

- Put the socket back into the light assembly, and turn it clockwise to lock it in place.
- Turn on the lights to make sure the new bulb is working.
- Put the light assembly back into the body, bottom first. Push on the top edge until it snaps into place.

Replacing Rear Bulbs

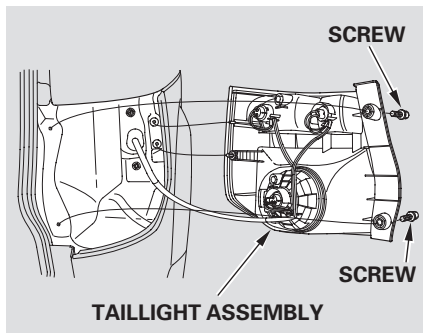

- Open the hatch and the tailgate. Remove the two mounting screws with a Phillips-head screwdriver, and remove the taillight assembly from the body by pulling it back.
- Determine which of the three bulbs is burned out: brake/taillight, turn signal light or back-up light.

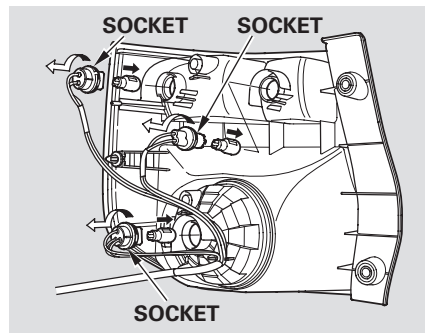

- Remove the socket by turning it one-quarter turn counterclockwise.
- Pull the bulb straight out of its socket. Push the new bulb straight into the socket until it bottoms.

5. Reinstall the socket into the light assembly by turning it clockwise until it locks.
6. Test the lights to make sure the new bulb is working.
7. When reinstalling the taillight assembly, first place the two pins in the holes in place. Tighten the two mounting bolts.

Replacing a Rear License Plate Bulb

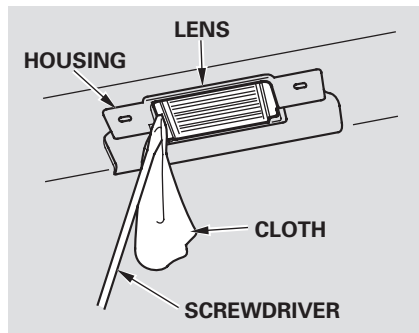

1. Place a cloth and insert a small flat-tip screwdriver between the left edge of the lens and the housing. The lens will come down.
2. Pull the bulb straight out of its socket. Push the new bulb in until it bottoms in the socket.

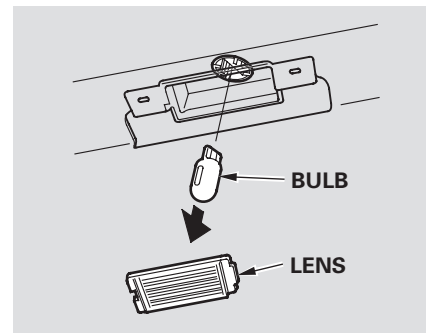

3. Turn on the parking lights and check that the new bulb is working.
4. Put the lens back into the light assembly, right side first. Push on the left edge until it snaps into place.

Lights

Replacing a High-mount Brake Light Bulb

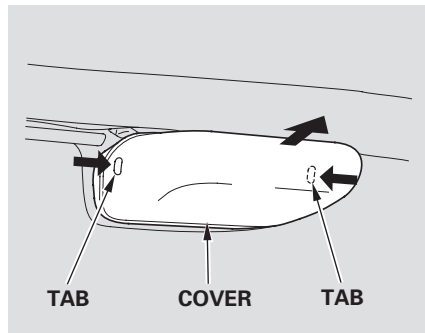

1. Open the hatch. Remove the light assembly cover by pushing in on the tabs on both sides and pulling the cover down.
2. Remove the socket from the light assembly by turning it one-quarter turn counterclockwise.

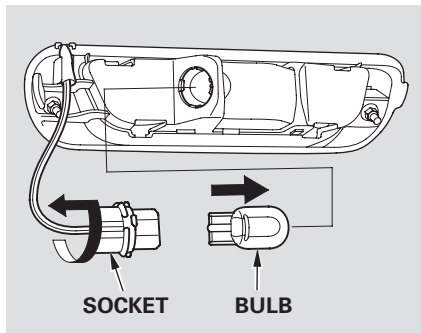

3. Pull the bulb straight out of its socket. Push the new bulb straight into the socket until it bottoms.

4. Test the lights to make sure the new bulb is working.
5. Put the socket back into the light assembly, and turn it clockwise to lock it in place.
6. Put the cover back onto the light assembly. Push it on until it locks in place.

Cleaning the Seat Belts, Dust and Pollen Filter

Cleaning the Seat Belts

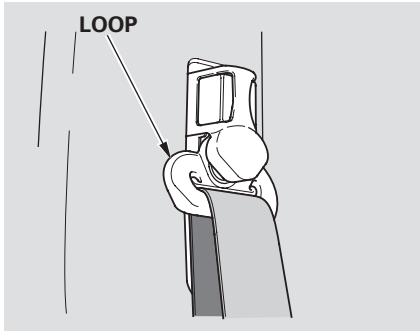

If your seat belts get dirty, use a soft brush with a mixture of mild soap and warm water to clean them. Do not use bleach, dye, or cleaning solvents. Let the belts air-dry before you use the vehicle.

Dirt build-up in the loops of the seat belt anchors can cause the belts to retract slowly. Wipe the insides of the loops with a clean cloth dampened in mild soap and warm water or isopropyl alcohol.

Dust and Pollen Filter

This filter removes the dust and pollen that is brought in from the outside through the heating and cooling system.

Have your dealer replace this filter every 30,000 miles (48,000 km) under normal conditions. It should be replaced every 15,000 miles (24,000 km) if you drive primarily in urban areas that have high concentrations of soot in the air, or if the flow from the heating and cooling system becomes less than usual.

Wiper Blades

Check the condition of the wiper blades at least every 6 months. Replace them if you find signs of cracking in the rubber, areas that are getting hard, or if they leave streaks and unwiped areas when used.

1. Front:

Raise the wiper arm off the windshield.

NOTICE

Do not open the hood when the wiper arms are raised, or you will damage the hood and the arms.

Rear:

Raise the wiper arm off the hatch glass and hold it.

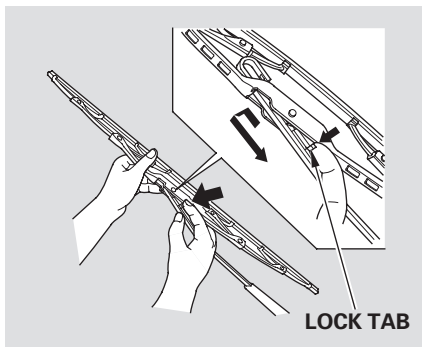

2. Disconnect the blade assembly from the wiper arm by pushing in the lock tab. Hold the lock tab in while you push the blade assembly toward the base of the arm.

If you are changing the rear wiper blade, go to step 6.

3. Remove the blade from its holder by grasping the tabbed end of the blade. Pull firmly until the tabs come out of the holder.

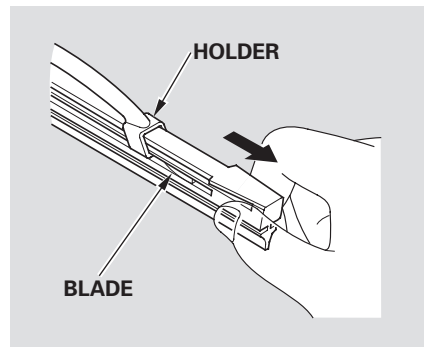

4. Examine the new wiper blades. If they have no plastic or metal reinforcement along the back edge, remove the metal reinforcement strips from the old wiper blade, and install them in the slots along the edge of the new blade.

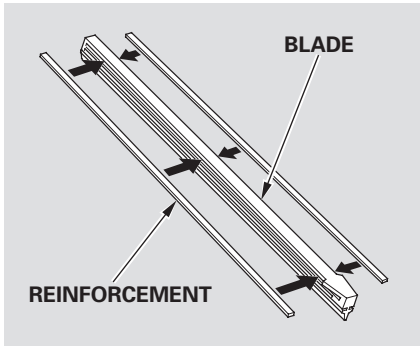

5. Slide the new wiper blade into the holder until the tabs lock.
6. Slide the wiper blade assembly onto the wiper arm. Make sure it locks in place.
7. Lower the wiper arm down against the windshield or the hatch glass.

Tires

To safely operate your vehicle, your tires must be the proper type and size, in good condition with adequate tread, and correctly inflated.

The following pages give more detailed information on how to take care of your tires and what to do when they need to be replaced.

⚠ WARNING

Using tires that are excessively worn or improperly inflated can cause a crash in which you can be seriously hurt or killed.

Follow all instructions in this owner's manual regarding tire inflation and maintenance.

Inflation Guidelines

Keeping the tires properly inflated provides the best combination of handling, tread life, and riding comfort.

- Underinflated tires wear unevenly, adversely affect handling and fuel economy, and are more likely to fail from being overheated.
- Overinflated tires can make your vehicle ride more harshly, are more prone to damage from road hazards, and wear unevenly.

We recommend that you visually check your tires everyday. If you think a tire might be low, check it immediately with a tire gauge.

CONTINUED

Tires

Use a gauge to measure the air pressure in each tire at least once a month. Even tires that are in good condition may lose 1 to 2 psi (10 to 20 kPa, 0.1 to 0.2 kgf/cm²) per month. Remember to check the spare tire at the same time.

Check the air pressures when the tires are cold. This means the vehicle has been parked for at least 3 hours, or driven less than 1 mile (1.6 km). Add or release air, if needed, to match the recommended cold tire pressures.

If you check air pressures when the tires are hot (driven for several miles), you will see readings 4 to 6 psi (30 to 40 kPa, 0.3 to 0.4 kgf/cm²) higher than the cold readings. This is normal. Do not let air out to match the recommended cold air pressure. The tire will be underinflated.

You should get your own tire pressure gauge and use it whenever you check your tire pressures. This will make it easier for you to tell if a pressure loss is due to a tire problem and not due to a variation between gauges.

While tubeless tires have some ability to self-seal if they are punctured, you should look closely for punctures if a tire starts losing pressure.

Recommended Tire Pressures for Normal Driving

The following chart shows the recommended cold tire pressures for most normal driving conditions and speed.

Tire Size	Cold Tire Pressure for Normal Driving
P215/70R16 99S	Front: 32 psi (220 kPa , 2.2 kgf/cm ²) Rear: 34 psi (235 kPa , 2.4 kgf/cm ²)

The compact spare tire pressure is:
60 psi (420 kPa , 4.2 kgf/cm²)

For convenience, the recommended tire sizes and cold tire pressures are on a label on the driver's doorjamb.

For additional technical information about your tires, see page [224](#).

Tire Inspection

Every time you check inflation, you should also examine the tires for damage, foreign objects, and wear.

You should look for:

- Bumps or bulges in the tread or side of the tire. Replace the tire if you find either of these conditions.
- Cuts, splits, or cracks in the side of the tire. Replace the tire if you can see fabric or cord.
- Excessive tread wear.

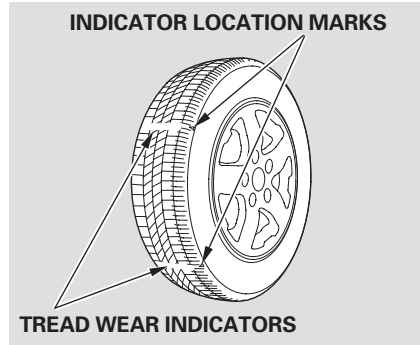

Your tires have wear indicators molded into the tread. When the tread wears down, you will see a band 1/2 inch (12.7 mm) wide across the tread. This shows there is less than 1/16 inch (1.6 mm) of tread left on the tire. A tire that is this worn gives very little traction on wet roads. You should replace the tire if you can see the tread wear indicator in three or more places on the tire.

Tire Maintenance

In addition to proper inflation, correct wheel alignment helps to decrease tire wear. If you find a tire is worn unevenly, have your dealer check the wheel alignment.

Have your dealer check the tires if you feel a consistent vibration while driving. A tire should always be rebalanced if it is removed from the wheel. When you have new tires installed, make sure they are balanced. This increases riding comfort and tire life. For best results, have the installer perform a dynamic balance.

NOTICE

For vehicles with aluminum wheels: Improper wheel weights can damage your vehicle's aluminum wheels. Use only genuine Honda wheel weights for balancing.

Tires

Tire Rotation

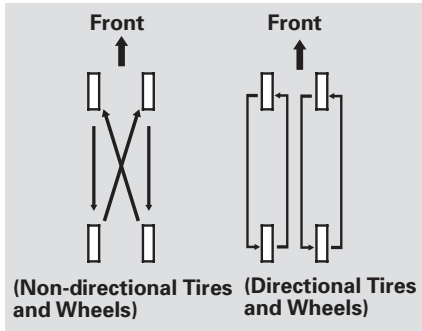

To help increase tire life and distribute wear more evenly, rotate the tires every 10,000 miles (16,000 km). Move the tires to the positions shown in the illustration each time they are rotated. If you purchase directional tires, rotate only front-to-back.

Replacing Tires and Wheels

Replace your tires with radial tires of the same size, load range, speed rating, and maximum cold tire pressure rating (as shown on the tire's sidewall).

Mixing radial and bias-ply tires on your vehicle can reduce braking ability, traction, and steering accuracy. Using tires of a different size or construction can cause the ABS to work inconsistently.

It is best to replace all four tires at the same time. If that is not possible or necessary, replace the two front tires or two rear tires as a pair. Replacing just one tire can seriously affect your vehicle's handling.

If you ever replace a wheel, make sure that the wheel's specifications match those of the original wheels. Replacement wheels are available at your dealer.

WARNING

Installing improper tires on your vehicle can affect handling and stability. This can cause a crash in which you can be seriously hurt or killed.

Always use the size and type of tires recommended in this owner's manual.

Wheel and Tire Specifications

Wheels:

16 x 6 1/2JJ

16 x 6 1/2

Tires:

P215/70R16 99S

See page [224](#) for DOT tire quality grading information, and page [226](#) for tire size and labeling information.

Winter Driving

Tires marked “M + S” or “All Season” on the sidewall have an all-weather tread design suitable for most winter driving conditions.

For the best performance in snowy or icy conditions, you should install snow tires or tire chains. They may be required by local laws under certain conditions.

Snow Tires

If you mount snow tires on your vehicle, make sure they are radial tires of the same size and load range as original tires. Mount snow tires on all four wheels. The traction provided by snow tires on dry roads may be lower than your original tires. Check with the tire dealer for maximum speed recommendations.

Tires

Tire Chains

Because your vehicle has limited tire clearance, use only SAE Class “S” cable-type traction devices, with rubber chain tensioners, on the front tires. Use traction devices only when required by driving conditions or local laws. Make sure they are the correct size for your tires. Metal link-type “chains” should not be used.

When installing cables, follow the manufacturer’s instructions, and mount them as tight as you can. Make sure they are not contacting the brake lines or suspension. Drive slowly with them installed. If you hear them coming into contact with the body or chassis, stop and investigate. Remove them as soon as you begin driving on cleared roads.

NOTICE

Traction devices that are the wrong size or improperly installed can damage your vehicle’s brake lines, suspension, body, and wheels. Stop driving if they are hitting any part of the vehicle.

Checking the Battery

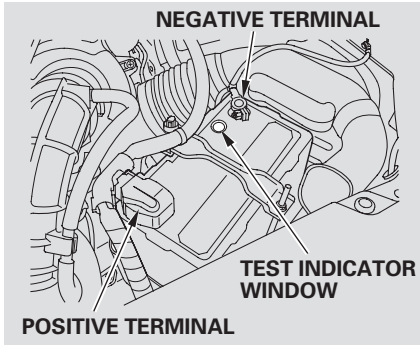

Check the condition of the battery monthly by looking at the test indicator window. The label on the battery explains the test indicator's colors.

Check the terminals for corrosion (a white or yellowish powder). To remove it, cover the terminals with a solution of baking soda and water. It will bubble up and turn brown. When this stops, wash it off with plain water. Dry off the battery with a cloth or paper towel. Coat the terminals with grease to help prevent future corrosion.

If additional battery maintenance is needed, see your dealer or a qualified technician.

WARNING: Battery posts, terminals, and related accessories contain lead and lead compounds. **Wash your hands after handling.**

If you need to connect the battery to a charger, disconnect both cables to prevent damaging your vehicle's electrical system. Always disconnect the negative (–) cable first, and reconnect it last.

⚠ WARNING

The battery gives off explosive hydrogen gas during normal operation.

A spark or flame can cause the battery to explode with enough force to kill or seriously hurt you.

Wear protective clothing and a face shield, or have a skilled mechanic do the battery maintenance.

Vehicle Storage

If you need to park your vehicle for an extended period (more than 1 month), there are several things you should do to prepare it for storage. Proper preparation helps prevent deterioration and makes it easier to get your vehicle back on the road. If possible, store your vehicle indoors.

- Fill the fuel tank.
- Change the engine oil and filter.
- Wash and dry the exterior completely.
- Clean the interior. Make sure the carpeting, floor mats, etc., are completely dry.
- Leave the parking brake off. Put the transmission in reverse (manual) or Park (automatic).

- Block the rear wheels.
- If the vehicle is to be stored for a longer period, it should be supported on jackstands so the tires are off the ground.
- Leave one window open slightly (if the vehicle is being stored indoors).
- Disconnect the battery.
- Support the front and rear wiper blade arms with a folded towel or rag so they do not touch the windshield.
- To minimize sticking, apply a silicone spray lubricant to all door and tailgate seals. Also, apply a vehicle body wax to the painted surfaces that mate with the door and tailgate seals.

- Cover the vehicle with a “breathable” cover, one made from a porous material such as cotton. Non-porous materials, such as plastic sheeting, trap moisture, which can damage the paint.
- If possible, periodically run the engine until it reaches full operating temperature (the cooling fan cycles twice). Preferably, do this once a month.

If you store your vehicle for 12 months or longer, have your dealer perform the inspections called for in the 24 months/30,000 miles (48,000 km) maintenance schedule (normal conditions) as soon as you take it out of storage (see page 165). The replacements called for in the maintenance schedule are not needed unless the vehicle has actually reached that time or mileage.

This section covers the more common problems that motorists experience with their vehicles. It gives you information about how to safely evaluate the problem and what to do to correct it. If the problem has stranded you on the side of the road, you may be able to get going again. If not, you will also find instructions on getting your vehicle towed.

Compact Spare Tire.....	196
Changing a Flat Tire	197
If the Engine Won't Start.....	203
Jump Starting	205
If the Engine Overheats	207
Low Oil Pressure Indicator	209
Charging System Indicator.....	209
Malfunction Indicator Lamp	210
Brake System Indicator	211
Fuses	212
Fuse Locations.....	215
Emergency Towing	217

Compact Spare Tire

Use the compact spare tire as a temporary replacement only. Get your regular tire repaired or replaced, and put it back on your vehicle as soon as you can.

Check the inflation pressure of the compact spare tire every time you check the other tires. It should be inflated to:
60 psi (420 kPa , 4.2 kgf/cm²)

Follow these precautions:

- Never exceed 50 mph (80 km/h).
- This tire gives a harsher ride and less traction on some road surfaces. Use greater caution while driving.
- Do not mount snow chains on the compact spare tire.
- Do not use your compact spare tire on another vehicle unless it is the same make and model.
- On models with manual transmission, do not drive for a long period with the compact spare tire mounted on a front wheel; it will damage the limited slip differential.

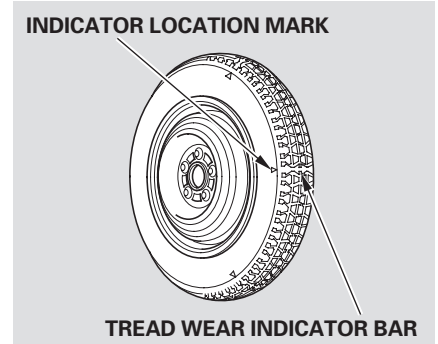

Replace the tire when you can see the tread wear indicator bars. The replacement should be the same size and design tire, mounted on the same wheel. The spare tire is not designed to be mounted on a regular wheel, and the spare wheel is not designed for mounting a regular tire.

Changing a Flat Tire

If you have a flat tire while driving, stop in a safe place to change it. Drive slowly along the shoulder until you get to an exit or an area to stop that is far away from the traffic lanes.

⚠️ WARNING

The vehicle can easily roll off the jack, seriously injuring anyone underneath.

Follow the directions for changing a tire exactly, and never get under the vehicle when it is supported only by the jack.

1. Park the vehicle on firm, level, and non-slippery ground. Put the transmission in Park (automatic) or reverse (manual). Apply the parking brake.

If you are towing a trailer, unhitch the trailer.

2. Turn on the hazard warning lights, and turn the ignition switch to the LOCK (0) position. Have all passengers get out of the vehicle while you change the tire.

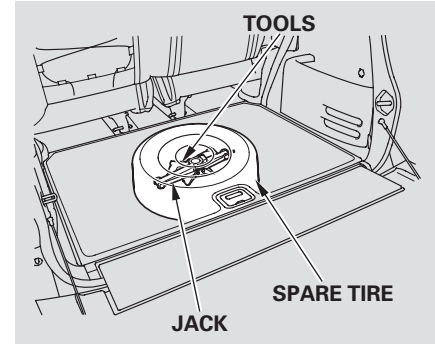

3. Open the hatch and the tailgate.
4. The spare tire, jack, and tools are under the cargo area floor.

CONTINUED

Changing a Flat Tire

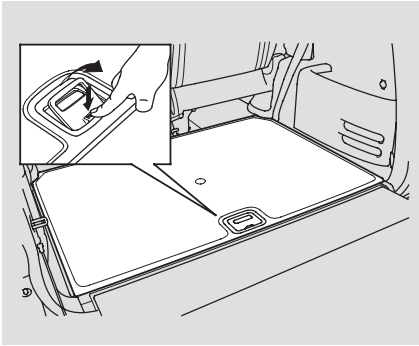

5. Push the rear edge of the handle to raise the handle loop and pull up the loop to raise the cargo area floor.

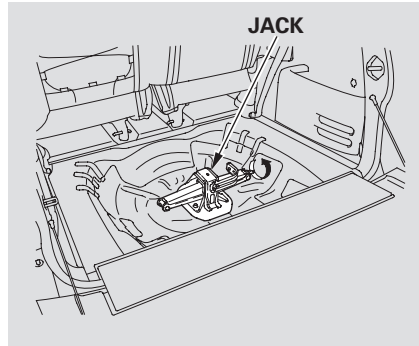

6. Unscrew the wing bolt, and take the spare tire out of the cargo area.

7. Remove the tools and the jack. To remove the jack, turn the jack's end bracket counterclockwise to loosen it.

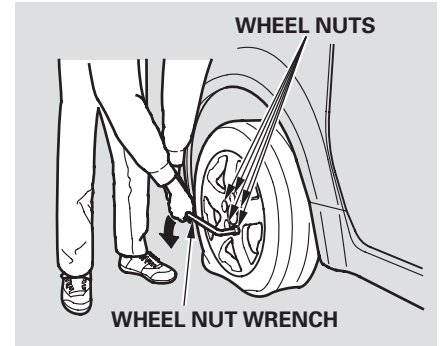

8. Loosen the five wheel nuts $1/2$ turn with the wheel nut wrench.

Changing a Flat Tire

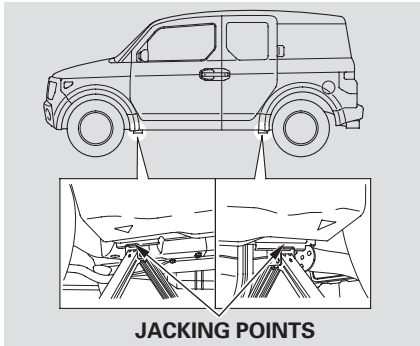

9. Locate the jacking point nearest the tire you need to change. It is pointed to by an arrow molded into the underside of the body. Place the jack under the jacking point. Turn the end bracket clockwise until the top of the jack contacts the jacking point. Make sure the jacking point tab is resting in the jack notch.

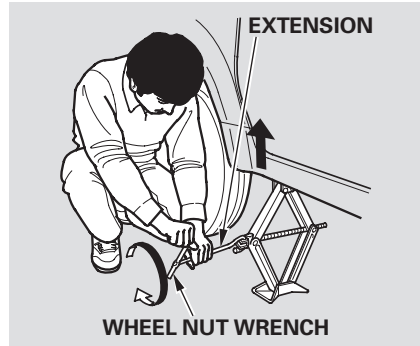

10. Use the extension and the wheel nut wrench as shown to raise the vehicle until the flat tire is off the ground.

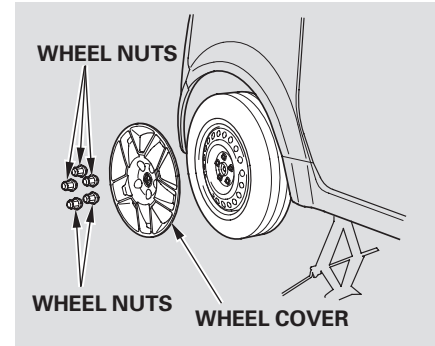

U.S. LX and Canadian Base models
Remove the wheel nuts and wheel cover. The wheel nuts will be very hot if you were recently driving. The wheel cover cannot be removed without first removing the wheel nuts. Do not attempt to forcibly pry the wheel cover off with a screwdriver or other tool.

CONTINUED

Changing a Flat Tire



11. Remove the wheel nuts and the flat tire. Temporarily place the flat tire on the ground with the outside surface of the wheel facing up.

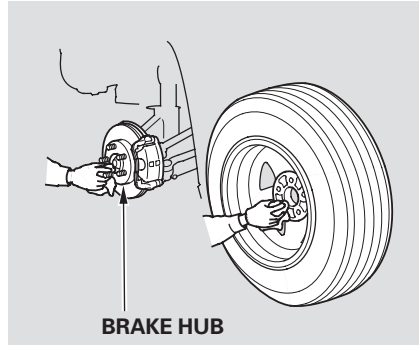

12. Before mounting the spare tire, wipe any dirt off the mounting surface of the wheel and hub with a clean cloth. Wipe the hub carefully; it may be hot from driving.

13. Put on the spare tire. Put the wheel nuts back on finger-tight, then tighten them in a crisscross pattern with the wheel nut wrench until the wheel is firmly against the hub. Do not try to tighten them fully.

Changing a Flat Tire

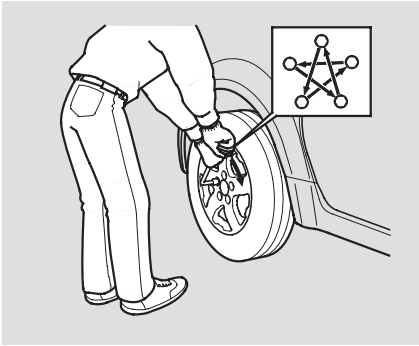

14. Lower the vehicle to the ground, and remove the jack.
15. Tighten the wheel nuts securely in the same crisscross pattern. Have the wheel nut torque checked at the nearest automotive service facility.
Tighten the wheel nuts to:
80 lbf·ft (108 N·m , 11 kgf·m)

16. Store the jack in its holder. Turn the jack's end bracket to lock it in place. Store the tools.

17. Remove the center cap from the flat tire, and store it in the spare tire well.

⚠ WARNING

Loose items can fly around the interior in a crash and could seriously injure the occupants.

Store the wheel, jack, and tools securely before driving.

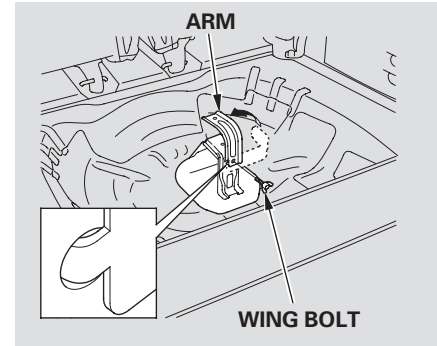

18. Remove the wing bolt on the spare tire mount, and pivot the arm 90° to the upright position. Then tighten the wing bolt securely.

CONTINUED

Changing a Flat Tire

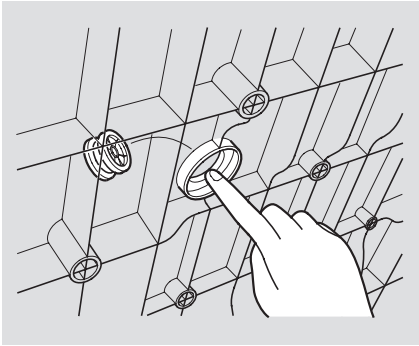

19. Remove the small round plug from the cargo area floor by pushing it from the back side to make a hole. Store the removed plug in a place you can easily remember.

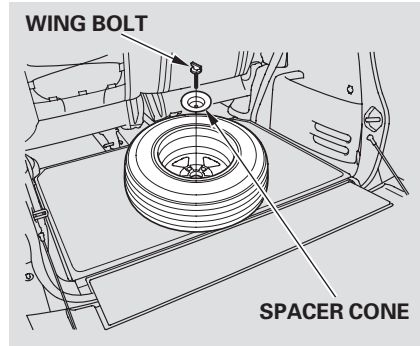

20. Reinstall the cargo area floor. Place the flat tire face down on the cargo area floor.

21. Align the center of the flat tire with the hole in the cargo area floor. Remove the spacer cone from the wing bolt, turn it over, and put it back on the bolt.

22. Secure the flat tire by screwing the wing bolt to the spare tire mount through the hole in the cargo area floor.

Diagnosing why the engine won't start falls into two areas, depending on what you hear when you turn the ignition switch to the START (III) position:

- You hear nothing, or almost nothing. The engine's starter motor does not operate at all, or operates very slowly.
- You can hear the starter motor operating normally, or the starter motor sounds like it is spinning faster than normal, but the engine does not start up and run.

Nothing Happens or the Starter Motor Operates Very Slowly

When you turn the ignition switch to the START (III) position, you do not hear the normal noise of the engine trying to start. You may hear a clicking sound or series of clicks, or nothing at all.

Check these things:

- Check the transmission interlock. If you have a manual transmission, the clutch pedal must be pushed all the way to the floor or the starter will not operate. With an automatic transmission, the shift lever must be in Park or neutral.
- Turn the ignition switch to the ON (II) position. Turn on the headlights, and check their brightness. If the headlights are very dim or do not come on at all, the battery is discharged (see **Jump Starting** on page 205).

- Turn the ignition switch to the START (III) position. If the headlights do not dim, check the condition of the fuses. If the fuses are OK, there is probably something wrong with the electrical circuit for the ignition switch or starter motor. You will need a qualified technician to determine the problem (see **Emergency Towing** on page 217).

If the headlights dim noticeably or go out when you try to start the engine, either the battery is discharged or the connections are corroded. Check the condition of the battery and terminal connections (see page 193). You can then try jump starting the vehicle from a booster battery (see page 205).

CONTINUED

If the Engine Won't Start

The Starter Operates Normally

In this case, the starter motor's speed sounds normal, or even faster than normal, when you turn the ignition switch to the START (III) position, but the engine does not run.

- Are you using a properly coded key? An improperly coded key will cause the immobilizer system indicator in the instrument panel to blink rapidly (see page 55).
- Are you using the proper starting procedure? Refer to **Starting the Engine** on page 140 .

- Do you have fuel? Check the fuel gauge; the low fuel indicator may not be working.
- There may be an electrical problem, such as no power to the fuel pump. Check all the fuses (see page 212).

If you find nothing wrong, you will need a qualified technician to find the problem (see **Emergency Towing** on page 217).

Although this seems like a simple procedure, you should take several precautions.

⚠ WARNING

A battery can explode if you do not follow the correct procedure, seriously injuring anyone nearby.

Keep all sparks, open flames, and smoking materials away from the battery.

You cannot start your vehicle with an automatic transmission by pushing or pulling it.

To Jump Start Your Vehicle:

1. Open the hood, and check the physical condition of the battery. In very cold weather, check the condition of the electrolyte. If it seems slushy or frozen, do not try jump starting until it thaws.

NOTICE

If a battery sits in extreme cold, the electrolyte inside can freeze. Attempting to jump start with a frozen battery can cause it to rupture.

2. Turn off all the electrical accessories: heater, A/C, stereo system, lights, etc. Put the transmission in neutral or Park, and set the parking brake.
3. Connect one jumper cable to the positive (+) terminal on your battery. Connect the other end to the positive (+) terminal on the booster battery.

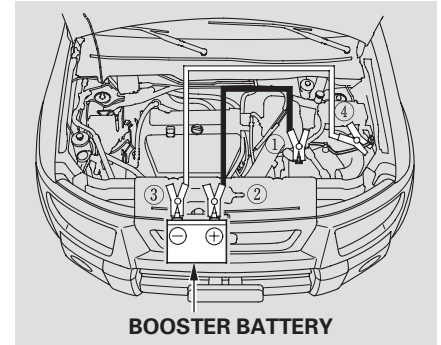

BOOSTER BATTERY

The numbers in the illustration show you the order to connect the jumper cables.

CONTINUED

Jump Starting

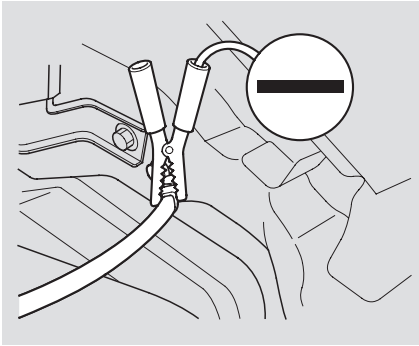

4. Connect the second jumper cable to the negative (–) terminal on the booster battery. Connect the other end to the grounding strap on your vehicle as shown. Do not connect this jumper cable to any other part of the engine.

5. If the booster battery is in another vehicle, have an assistant start that vehicle and run it at a fast idle.
6. Start your vehicle. If the starter motor still operates slowly, check that the jumper cables have good metal-to-metal contact.
7. Once your vehicle is running, disconnect the negative cable from your vehicle, then from the booster battery. Disconnect the positive cable from your vehicle, then from the booster battery.

Keep the ends of the jumper cables away from each other and any metal on the vehicle until everything is disconnected. Otherwise, you may cause an electrical short.

If the Engine Overheats

The pointer of the vehicle's temperature gauge should stay in the midrange. If it climbs to the red mark, you should determine the reason (hot day, driving up a steep hill, etc.).

If the vehicle overheats, you should take immediate action. The only indication may be the temperature gauge climbing to or above the red mark. Or you may see steam or spray coming from under the hood.

NOTICE

Driving with the temperature gauge pointer at the red mark can cause serious damage to the engine.

WARNING

Steam and spray from an overheated engine can seriously scald you.

Do not open the hood if steam is coming out.

1. Safely pull to the side of the road. Put the transmission in neutral (manual) or Park (automatic), and set the parking brake. Turn off all the accessories, and turn on the hazard indicators.
2. If you see steam and/or spray coming from under the hood, turn off the engine. Wait until you see no more signs of steam or spray, then open the hood.

3. If you do not see steam or spray, leave the engine running, and watch the temperature gauge. If the high heat is due to overloading, the engine should start to cool down almost immediately. If it does, wait until the temperature gauge comes down to the midpoint, then continue driving.
4. If the temperature gauge stays at the red mark, turn off the engine.

CONTINUED

If the Engine Overheats

5. Look for any obvious coolant leaks, such as a split radiator hose. Everything is still extremely hot, so use caution. If you find a leak, it must be repaired before you continue driving (see **Emergency Towing** on page 217).
6. If you don't find an obvious leak, check the coolant level in the radiator reserve tank (see page 128).
7. If there was no coolant in the reserve tank, you may need to add coolant to the radiator. Let the engine cool down until the pointer reaches the middle of the temperature gauge or lower before checking the radiator.

WARNING

Removing the radiator cap while the engine is hot can cause the coolant to spray out, seriously scalding you.

Always let the engine and radiator cool down before removing the radiator cap.

8. Using gloves or a large heavy cloth, turn the radiator cap counterclockwise, without pushing down, to the first stop. After the pressure releases, push down on the cap, and turn it until it comes off.
9. Start the engine, and set the temperature control dial to maximum heat. Add coolant to the radiator up to the base of the filler neck. If you do not have the proper coolant mixture available, you can add plain water. Remember to have the cooling system drained and refilled with the proper mixture as soon as you can.
10. Put the radiator cap back on tightly. Run the engine, and watch the temperature gauge. If it goes back to the red mark, the engine needs repair (see **Emergency Towing** on page 217).
11. If the temperature stays normal, check the coolant level in the radiator reserve tank. If it has gone down, add coolant to the MAX mark. Put the cap back on tightly.

Low Oil Pressure Indicator, Charging System Indicator

Low Oil Pressure Indicator



This indicator should never come on when the engine is running. If it starts flashing or stays on, the oil pressure has dropped very low. Serious engine damage is possible and you should take immediate action.

NOTICE

Running the engine with low oil pressure can cause serious mechanical damage almost immediately. Turn off the engine as soon as you can safely get the vehicle stopped.

1. Safely pull off the road, and shut off the engine. Turn on the hazard warning lights.
2. Let the vehicle sit for a minute. Open the hood, and check the oil level (see page 128). An engine very low on oil can lose pressure during cornering and other driving maneuvers.
3. If necessary, add oil to bring the level back to the full mark on the dipstick (see page 170).
4. Start the engine, and watch the oil pressure indicator. If it does not go out within 10 seconds, turn off the engine. There is a mechanical problem that needs to be repaired before you can continue driving (see **Emergency Towing** on page 217).

Charging System Indicator



If the charging system indicator comes on brightly when the engine is running, the battery is not being charged.

Immediately turn off all electrical accessories. Try not to use other electrically operated controls such as the power windows. Keep the engine running; starting the engine will discharge the battery rapidly.

Go to a service station or garage where you can get technical assistance.

Malfunction Indicator Lamp



If this indicator comes on while driving, it means one of the engine's emissions control systems may have a problem. Even though you may feel no difference in your vehicle's performance, it can reduce your fuel economy and cause increased emissions. Continued operation may cause serious damage.

If you have recently refueled your vehicle, the indicator coming on could be due to a loose or missing fuel fill cap. Tighten the cap until it clicks at least three times. Tightening the cap will not turn the indicator off immediately; it takes several days of normal driving.

If the indicator comes on repeatedly, even though it may turn off as you continue driving, have the vehicle checked by the dealer as soon as possible.

NOTICE

If you keep driving with the malfunction indicator lamp on, you can damage your vehicle's emissions controls and engine. Those repairs may not be covered by your vehicle's warranties.

Readiness Codes

Your vehicle has certain "readiness codes" that are part of the on-board diagnostics for the emissions systems. In some states, part of the emissions testing is to make sure these codes are set. If they are not set, the test cannot be completed.

If your vehicle's battery has been disconnected or gone dead, these codes are erased. It takes several days of driving under various conditions to set the codes again.

To check if they are set, turn the ignition switch to the ON (II) position, without starting the engine. The malfunction indicator lamp will come on for 20 seconds. If it then goes off, the readiness codes are set. If it blinks five times, the readiness codes are not set. If possible, do not take your vehicle for a state emissions test until the readiness codes are set. Refer to **State Emissions Testing** for more information (see page [230](#)).

U.S.

BRAKE

Canada



The brake system indicator normally comes on when you turn the ignition switch to the ON (II) position, and as a reminder to check the parking brake. It will stay on if you do not fully release the parking brake.

If the brake system indicator comes on while driving, the brake fluid level is probably low. Press lightly on the brake pedal to see if it feels normal. If it does, check the brake fluid level the next time you stop at a service station (see page [177](#)).

If the fluid level is low, take your vehicle to a dealer, and have the brake system inspected for leaks or worn brake pads.

However, if the brake pedal does not feel normal, you should take immediate action. A problem in one part of the system's dual circuit design will still give you braking at two wheels. You will feel the brake pedal go down much farther before the vehicle begins to slow down, and you will have to press harder on the pedal.

Slow down by shifting to a lower gear, and pull to the side of the road when it is safe. Because of the long distance needed to stop, it is hazardous to drive the vehicle. You should have it towed and repaired as soon as possible (see **Emergency Towing** on page [217](#)).

If you must drive the vehicle a short distance in this condition, drive slowly and carefully.

Fuses

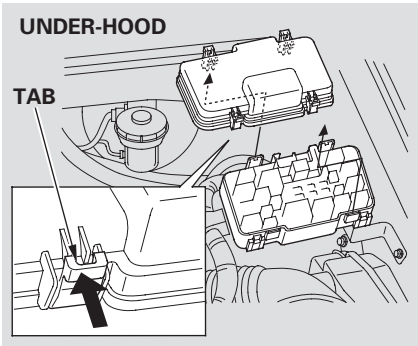

The vehicle's fuses are located in two fuse boxes. The under-hood fuse box is located in the engine compartment on the driver's side. To open it, push the tabs as shown.

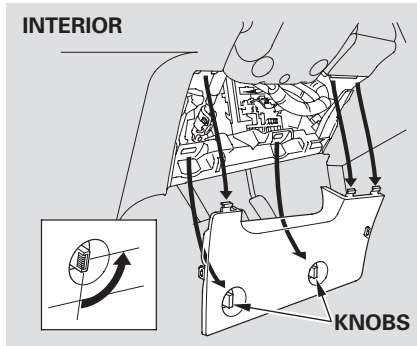

The interior fuse box is underneath the steering column. To remove the fuse box lid, turn the knobs counterclockwise and pull the lid out of its hinges.

Checking and Replacing Fuses

If something electrical in your vehicle stops working, check for a blown fuse first. Determine from the chart on pages [215](#) and [216](#), or the diagram on the fuse box lid, which fuse or fuses control that device. Check those fuses first, but check all the fuses before deciding that a blown fuse is the cause. Replace any blown fuses, and check if the device works.

1. Turn the ignition switch to the LOCK (0) position. Make sure the headlights and all other accessories are off.
2. Remove the cover from the fuse box.

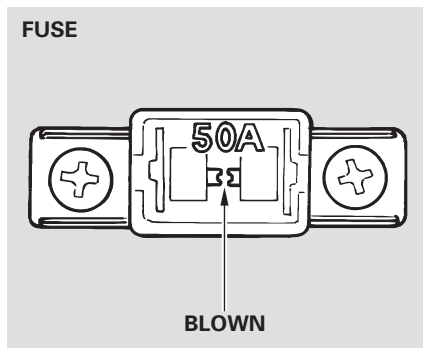

3. Check each of the large fuses in the under-hood fuse box by looking through the top at the wire inside. Remove the screws with a Phillips-head screwdriver.

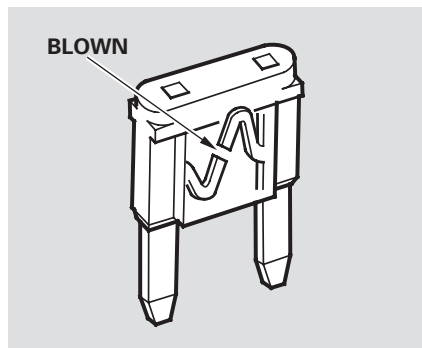

4. Check the smaller fuses in the under-hood fuse box and all the fuses in the interior fuse box by pulling out each one with the fuse puller provided in the under-hood fuse box.
5. Look for a blown wire inside the fuse. If it is blown, replace it with one of the spare fuses of the same rating or lower.

If you cannot drive the vehicle without fixing the problem, and you do not have a spare fuse, take a fuse of the same rating or a lower rating from one of the other circuits. Make sure you can do without that circuit temporarily (such as the accessory power socket or radio).

If you replace the blown fuse with a spare fuse that has a lower rating, it might blow out again. This does not indicate anything wrong. Replace the fuse with one of the correct rating as soon as you can.

CONTINUED

Fuses

NOTICE

Replacing a fuse with one that has a higher rating greatly increases the chances of damaging the electrical system. If you do not have a replacement fuse with the proper rating for the circuit, install one with a lower rating.

6. If the replacement fuse of the same rating blows in a short time, there is probably a serious electrical problem in your vehicle. Leave the blown fuse in that circuit and have your vehicle checked by a qualified mechanic.

On U.S. EX models and Canadian Y package

If the radio fuse is removed, the audio system will disable itself. The next time you turn on the radio you will see “CODE” in the frequency display. Use the preset buttons to enter the five-digit code (see page [116](#)).

Fuse Locations

INTERIOR FUSE BOX

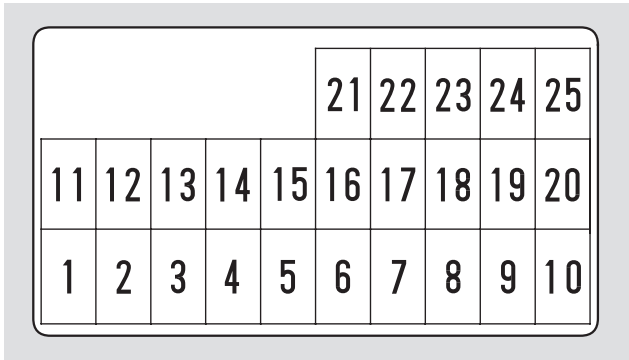

No.	Amps.	Circuits Protected
1	15 A	Ignition Coil
2	15 A	+B ACC
3	10 A	+B Daytime running lights*2
4	10 A	IG1 ACG
5	—	Not Used

No.	Amps.	Circuits Protected
6	7.5 A	Power Window Relay
7	20 A	AMP
8	7.5 A	Accessory, Radio
9	10 A	Rear Wiper
10	7.5 A	Meter
11	7.5 A	ABS
12	7.5 A	IG2 Daytime running lights*2
13	10 A	SRS
14	10 A	Remote Control Mirrors
15	20 A	LAF Heater
16	—	Not Used
17	15 A	Fuel Pump
18	15 A	Front Accessory Power Socket
19	7.5 A	Turn Signal Lights
20	20 A	Front Wiper
21	—	Not Used
22	20 A	Passenger's Power Window
23	20 A	Driver's Power Window
24	—	Not Used
25	—	Not Used

* 1 : If equipped

* 2 : Canadian models

Taking Care of the Unexpected

CONTINUED

Fuse Locations

UNDER-HOOD FUSE BOX

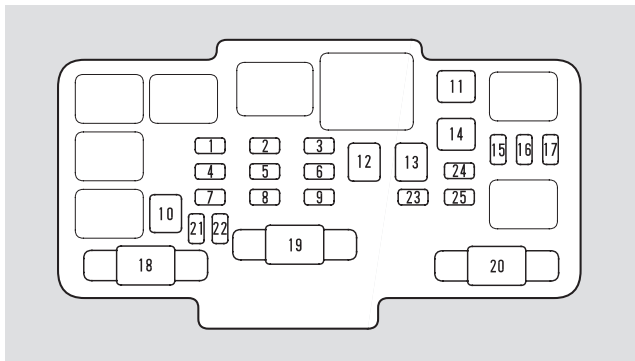

No.	Amps.	Circuits Protected
1	30 A	Condenser Fan
2	15 A	Small Light
3	7.5 A	Interior Light
4	20 A	Cooling Fan Motor
5	15 A	Hazard
6	15 A	IGP
7	15 A	Horn, Stop
8	—	Not Used
9	10 A	Back Up
10	30 A	ABS Motor
11	20 A	Rear Defroster
12	40 A	Heater Motor
13	40 A	Power Window Main
14	40 A	Option
15	15 A	Left Headlight
16	15 A	Door Lock
17	15 A	Right Headlight
18	30 A	ABS MTR FSR
19	100 A	Battery
20	50 A	IG1 Main
21-25	7.5A-30A	Spare Fuses

If your vehicle needs to be towed, call a professional towing service or organization. Never tow your vehicle with just a rope or chain. It is very dangerous.

The only way you can safely tow your vehicle is with flat-bed equipment. The operator will load your vehicle on the back of a truck. Any other method of towing will damage the drive system. When you contact the towing agency, inform them a flat-bed is required.

NOTICE

Towing with only two tires on the ground will damage parts of the 4WD system. It should be transported on a flat-bed truck or trailer.

The diagrams in this section give you the dimensions and capacities of your vehicle, and the locations of the identification numbers. It also includes information you should know about your vehicle’s tires and emissions control systems.

- Identification Numbers..... 220
- Specifications 222
- DOT Tire Quality Grading
 - (U.S. Vehicles) 224
 - Uniform Tire Quality Grading 224
 - Treadwear 224
 - Traction..... 224
 - Temperature 225
- Tire Labeling..... 226

- Emissions Controls..... 227
 - The Clean Air Act..... 227
 - Crankcase Emissions Control System..... 227
 - Evaporative Emissions Control System..... 227
 - Onboard Refueling Vapor Recovery 227
- Exhaust Emissions Controls ... 228
 - PGM-FI System 228
 - Ignition Timing Control System..... 228
 - Three Way Catalytic Converter..... 228
- Replacement Parts..... 228
- Three Way Catalytic Converter... 229
- State Emissions Testing 230

Identification Numbers

Your vehicle has several identifying numbers located in various places.

The vehicle identification number (VIN) is the 17-digit number your dealer uses to register your vehicle for warranty purposes. It is also necessary for licensing and insuring your vehicle. The easiest place to find the VIN is on a plate fastened to the top of the dashboard. You can see it by looking through the windshield on the driver's side. It is also on the certification label attached to the driver's doorjamb (front edge of rear door), and is stamped on the engine compartment bulkhead. The VIN is also provided in bar code on the certification label.

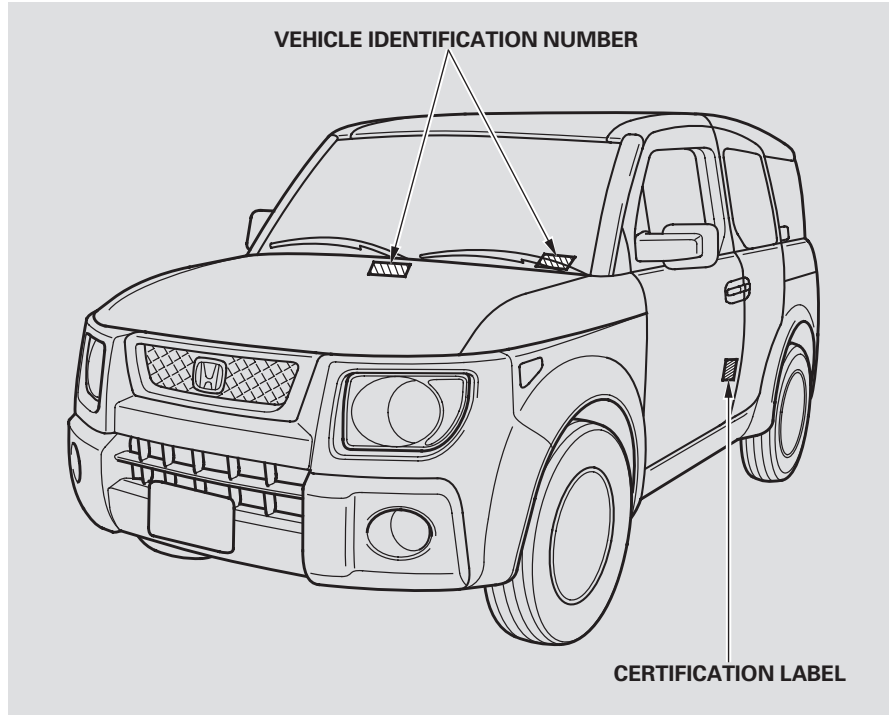

Identification Numbers

The engine number is stamped into the engine block.

The transmission number is on a label on top of the transmission.

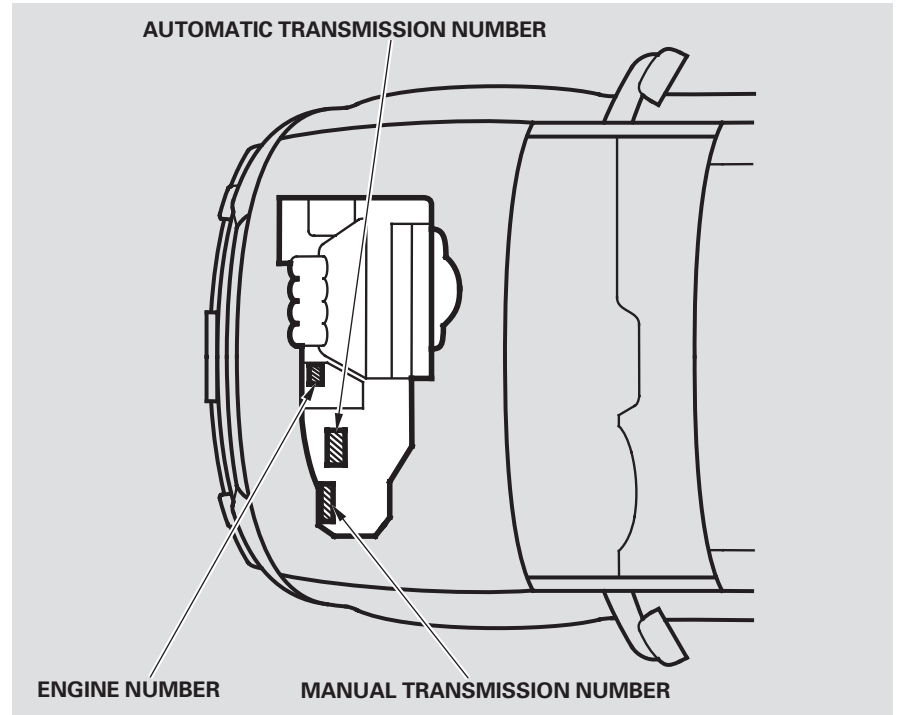

Specifications

Dimensions

Length	169.3 in (4,300 mm)
Width	71.5 in (1,815 mm)
Height	70.4 in (1,788 mm)
Wheelbase	101.4 in (2,575 mm)
Track	62.1 in (1,577 mm)
	Front
	Rear
	62.3 in (1,582 mm)

Weights

Gross vehicle weight rating	See the certification label attached to the driver's doorjamb (front edge of rear door).
-----------------------------	--

Engine

Type	Water cooled 4-stroke DOHC VTEC 4-cylinder gasoline engine
Bore x Stroke	3.43 x 3.90 in (87.0 x 99.0 mm)
Displacement	144 cu-in (2,354 cm ³)
Compression ratio	9.7 : 1
Spark plugs	NGK: IZFR6K-11 DENSO: SKJ20DR-M11

Capacities

Fuel tank	Approx. 15.9 US gal (60 ℓ)
Engine oil	Change* ¹
	Including filter
	Without filter
	Total
	4.4 US qt (4.2 ℓ)
	4.2 US qt (4.0 ℓ)
	5.6 US qt (5.3 ℓ)

Engine coolant	Automatic Transmission	
	Change* ²	1.43 US gal (5.4 ℓ)
	Total	1.88 US gal (7.1 ℓ)
	Manual Transmission	
	Change* ²	1.45 US gal (5.5 ℓ)
	Total	1.90 US gal (7.2 ℓ)
Automatic transmission fluid	Change	
	4WD	3.3 US qt (3.1 ℓ)
	2WD	3.1 US qt (2.9 ℓ)
	Total	
	4WD	7.6 US qt (7.2 ℓ)
	2WD	6.9 US qt (6.5 ℓ)
Manual transmission fluid	Change	2.0 US qt (1.9 ℓ)
	Total	
	4WD	2.4 US qt (2.3 ℓ)
	2WD	2.3 US qt (2.2 ℓ)
Rear differential fluid (4WD)	Change	1.1 US qt (1.0 ℓ)
	Total	1.3 US qt (1.2 ℓ)
Windshield washer reservoir		4.8 US qt (4.5 ℓ)

* 1 : Excluding the oil remaining in the engine

* 2 : Including the coolant in the reserve tank and that remaining in the engine

Reserve tank capacity:
0.145 US gal (0.55 ℓ)

Air Conditioning

Refrigerant type	HFC-134a (R-134a)
Charge quantity	16.9 – 18.7 oz (480 – 530 g)
Lubricant type	SP-10

Lights

Headlights	12 V – 60/55 W (H4/HB2)
Front turn signal/parking lights	12 V – 21/5 W
Front side marker lights	12 V – 3 CP
Rear turn signal lights	12 V – 21 W
Brake/Taillights	12 V – 21/5 W
Back-up lights	12 V – 18 W (21 CP)
License plate lights	12 V – 5 W
Ceiling light	12 V – 8 W
Spotlights	12 V – 4 CP
Cargo area light	12 V – 8 W
High-mount brake light	12 V – 21 W

Battery

Capacity	12 V – 45 AH/20 HR
----------	--------------------

Fuses

Interior	See page 215 or the fuse label attached to the inside of the fuse box door under the steering column.
Under-hood	See page 216 or the fuse box cover.

Alignment

Toe-in	Front	0.0 in (0 mm)
	Rear	0.08 in (2.0 mm)
Camber	Front	–0°13'
	Rear	–1°
Caster	Front	1°50'

Tires

Size	Front/Rear	P215/70R16 99S
Pressure	Front	32 psi (220 kPa , 2.2 kgf/cm ²)
	Rear	34 psi (235 kPa , 2.4 kgf/cm ²)
	Spare	60 psi (420 kPa , 4.2 kgf/cm ²)

DOT Tire Quality Grading (U.S. Vehicles)

The tires on your vehicle meet all U.S. Federal Safety Requirements. All tires are also graded for treadwear, traction, and temperature performance according to Department of Transportation (DOT) standards. The following explains these gradings.

Uniform Tire Quality Grading

Quality grades can be found where applicable on the tire sidewall between the tread shoulder and the maximum section width. For example:

Treadwear 200
Traction AA
Temperature A

All passenger car tires must conform to Federal Safety Requirements in addition to these grades.

Treadwear

The treadwear grade is a comparative rating based on the wear rate of the tire when tested under controlled conditions on a specified government test course. For example, a tire graded 150 would wear one and one-half (1 1/2) times as well on the government course as a tire graded 100. The relative performance of tires depends upon the actual conditions of their use, however, and may depart significantly from the norm due to variations in driving habits, service practices, and differences in road characteristics and climate.

Traction – AA, A, B, C

The traction grades, from highest to lowest, are AA, A, B, and C. Those grades represent the tire's ability to stop on wet pavement as measured under controlled conditions on specified government test surfaces of asphalt and concrete. A tire marked C may have poor traction performance.

Warning: The traction grade assigned to this tire is based on straight-ahead braking traction tests, and does not include acceleration, cornering, hydroplaning, or peak traction characteristics.

DOT Tire Quality Grading (U.S. Vehicles)

Temperature – A, B, C

The temperature grades are A (the highest), B, and C, representing the tire's resistance to the generation of heat and its ability to dissipate heat when tested under controlled conditions on a specified indoor laboratory test wheel. Sustained high temperature can cause the material of the tire to degenerate and reduce tire life, and excessive temperature can lead to sudden tire failure. The grade C corresponds to a level of performance, which all passenger vehicle tires must meet under the Federal Motor Vehicle Safety Standard No. 109. Grades B and A represent higher levels of performance on the laboratory test wheel than the minimum required by law.

Warning: The temperature grade for this tire is established for a tire that is properly inflated and not overloaded. Excessive speed, underinflation, or excessive loading, either separately or in combination, can cause heat buildup and possible tire failure.

Tire Labeling

Tire Labeling

The tires that came on your vehicle have a number of markings. Those you should be aware of are described below.

Tire Size

Whenever tires are replaced, they should be replaced with tires of the same size. Following is an example of tire size with an explanation of what each component means.

P215/70R16 99S

- P – Vehicle type (P indicates passenger vehicle).
- 215 – Tire width in millimeters.
- 70 – Aspect ratio (the tire's section height as a percentage of its width).
- R – Tire construction code (R indicates radial).
- 16 – Rim diameter in inches.

- 99 – Load index (a numerical code associated with the maximum load the tire can carry).
- S – Speed symbol (an alphabetical code indicating the maximum speed rating).

Tire Identification Number

The tire identification number (TIN) is a group of numbers and letters that look like this example:

DOT B97R FW6X 2202

- DOT – This indicates that the tire meets all requirements of the U.S. Department of Transportation.
- B97R – Manufacturer's identification mark.
- FW6X – Tire type code.
- 2202 – Date of manufacture.

Maximum Tire Pressure

Max Press – The maximum air pressure the tire can hold.

Maximum Tire Load

Max Load – The maximum load the tire can carry at maximum air pressure.

The burning of gasoline in your vehicle's engine produces several by-products. Some of these are carbon monoxide (CO), oxides of nitrogen (NOx), and hydrocarbons (HC). Gasoline evaporating from the tank also produces hydrocarbons. Controlling the production of NOx, CO, and HC is important to the environment. Under certain conditions of sunlight and climate, NOx and HC react to form photochemical "smog." Carbon monoxide does not contribute to smog creation, but it is a poisonous gas.

The Clean Air Act

The United States Clean Air Act* sets standards for automobile emissions. It also requires that automobile manufacturers explain to owners how their emissions controls work and what to do to maintain them. This section summarizes how the emissions controls work. Scheduled maintenance is on page [163](#).

* In Canada, Honda vehicles comply with the Canadian emission requirements, as specified in an agreement with Environment Canada, at the time they are manufactured.

Crankcase Emissions Control System

Your vehicle has a positive crankcase ventilation system. This keeps gasses that build up in the engine's crankcase from going into the atmosphere. The positive

crankcase ventilation valve routes them from the crankcase back to the intake manifold. They are then drawn into the engine and burned.

Evaporative Emissions Control System

As gasoline evaporates in the fuel tank, an evaporative emissions control canister filled with charcoal adsorbs the vapor. It is stored in this canister while the engine is off. After the engine is started and warmed up, the vapor is drawn into the engine and burned during driving.

Onboard Refueling Vapor Recovery

The onboard refueling vapor recovery (ORVR) system captures the fuel vapors during refueling. The vapors are adsorbed in a canister filled with activated carbon. While driving, the fuel vapors are drawn into the engine and burned off.

Emissions Controls

Exhaust Emissions Controls

The exhaust emissions controls include three systems: PGM-FI, ignition timing control, and three way catalytic converter. These three systems work together to control the engine's combustion and minimize the amount of HC, CO, and NOx that comes out the tailpipe. The exhaust emissions control systems are separate from the crankcase and evaporative emissions control systems.

PGM-FI System

The PGM-FI system uses sequential multiport fuel injection. It has three subsystems: air intake, engine control, and fuel control. The powertrain control module (PCM) in automatic transmission vehicles or the engine control module (ECM) in manual transmission vehicles uses various sensors to determine how much air is going into the engine. It then controls how much fuel to inject under all operating conditions.

Ignition Timing Control System

This system constantly adjusts the ignition timing, reducing the amount of HC, CO, and NOx produced.

Three Way Catalytic Converter

The three way catalytic converter is in the exhaust system. Through chemical reactions, it converts HC, CO, and NOx in the engine's exhaust to carbon dioxide (CO₂), nitrogen (N₂), and water vapor.

Replacement Parts

The emissions control systems are designed and certified to work together in reducing emissions to levels that comply with the Clean Air Act. To make sure the emissions remain low, you should use only new Honda replacement parts or their equivalent for repairs. Using lower quality parts may increase the emissions from your vehicle.

The emissions control systems are covered by warranties separate from the rest of your vehicle. Read your warranty manual for more information.

Three Way Catalytic Converter

The three way catalytic converter contains precious metals that serve as catalysts, promoting chemical reactions to convert the exhaust gasses without affecting the metals. The catalytic converter is referred to as a three-way catalyst, since it acts on HC, CO, and NOx. A replacement unit must be an original Honda part or its equivalent.

The three way catalytic converter must operate at a high temperature for the chemical reactions to take place. It can set on fire any combustible materials that come near it. Park your vehicle away from high grass, dry leaves, or other flammables.

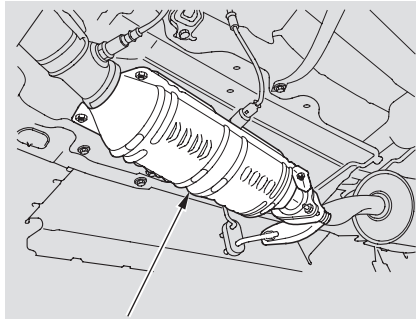

THREE WAY CATALYTIC CONVERTER

A defective three way catalytic converter contributes to air pollution, and can impair your engine's performance. Follow these guidelines to protect your vehicle's three way catalytic converter.

- Always use unleaded gasoline. Even a small amount of leaded gasoline can contaminate the catalyst metals, making the three way catalytic converter ineffective.

- Keep the engine tuned-up.
- Have your vehicle diagnosed and repaired if it is misfiring, back-firing, stalling, or otherwise not running properly.

State Emissions Testing

Testing of Readiness Codes

If you take your vehicle for a state emissions test shortly after the battery has been disconnected or gone dead, it may not pass the test. This is because of certain “readiness codes” that must be set in the on-board diagnostics for the emissions systems. These codes are erased when the battery is disconnected, and set again only after several days of driving under a variety of conditions.

If the testing facility determines that the readiness codes are not set, you will be requested to return at a later date to complete the test. If you must get the vehicle retested within the next two or three days, you can condition the vehicle for retesting by doing the following.

- Make sure the fuel tank is nearly, but not completely full (around 3/4).
 - Make sure the vehicle has been parked with the engine off for 6 hours or more.
 - Make sure the ambient temperature is between 40° and 95°F.
- Without touching the accelerator pedal, start the engine, and let it idle for 20 seconds.
 - Keep the vehicle in Park (automatic transmission) or neutral (manual transmission). Increase the engine speed to 2,000 rpm, and hold it there until the temperature gauge rises to at least 1/4 of the scale (about 3 minutes).

- Select a nearby lightly traveled major highway where you can maintain a speed of 50 to 60 mph (80 to 97 km/h) for at least 20 minutes. Drive on the highway in D (A/T) or 5th (M/T). Do not use cruise control. When traffic allows, drive for 90 seconds without moving the accelerator pedal. (Vehicle speed may vary slightly; this is okay.) If you cannot do this for a continuous 90 seconds because of traffic conditions, drive for at least 30 seconds, then repeat it two more times (for a total of 90 seconds).

- Then drive in city/suburban traffic for at least 10 minutes. When traffic conditions allow, let the vehicle coast for several seconds without using the accelerator pedal or the brake pedal.

If the testing facility determines the readiness codes are still not set, see your dealer.

Warranty and Customer Relations

Customer Service Information.....	234
Warranty Coverages	235
Reporting Safety Defects (U.S. Vehicles)	236
Authorized Manuals	237

Customer Service Information

Honda dealership personnel are trained professionals. They should be able to answer all your questions. If you encounter a problem that your dealership does not solve to your satisfaction, please discuss it with the dealership's management. The service manager or general manager can help. Almost all problems are solved in this way.

If you are dissatisfied with the decision made by the dealership's management, contact your Honda Customer Service Office.

U.S. Owners:

American Honda Motor Co., Inc.
Honda Automobile Customer Service
Mail Stop 500-2N-7A
1919 Torrance Boulevard
Torrance, California 90501-2746

Tel: (800) 999-1009

Canadian Owners: **CUSTOMER RELATIONS RELATIONS AVEC LA CLIENTÈLE**

Honda Canada Inc.
715 Milner Avenue
Toronto, ON
M1B 2K8

Tel: 1-888-9-HONDA-9
Fax: Toll-free 1-877-939-0909
Toronto (416) 287-4776

In Puerto Rico and the U.S. Virgin Islands:

Bella International
P.O. Box 190816
San Juan, PR 00919-0816

Tel: (787) 620-7098

When you call or write, please give us this information:

- Vehicle identification number (see page [220](#))
- Name and address of the dealer who services your vehicle
- Date of purchase
- Mileage on your vehicle
- Your name, address, and telephone number
- A detailed description of the problem
- Name of the dealer who sold the vehicle to you

U.S. Owners

Your new vehicle is covered by these warranties:

New Vehicle Limited Warranty – covers your new vehicle, except for the battery, emissions control systems, and accessories, against defects in materials and workmanship.

Emissions Control Systems Defects Warranty and Emissions Performance Warranty – these two warranties cover your vehicle’s emissions control systems. Time, mileage, and coverage are conditional. Please read your warranty booklet for exact information.

Original Equipment Battery Limited Warranty – this warranty gives up to 100 % credit toward a replacement battery.

Seat Belt Limited Warranty – a seat belt that fails to function properly is covered for the useful life of the vehicle.

Rust Perforation Limited Warranty – all exterior body panels are covered for rust-through from the inside for the specified time period with no mileage limit.

Accessory Limited Warranty – Honda accessories are covered under this warranty. Time and mileage limits depend on the type of accessory and other factors. Please read your warranty booklet for details.

Replacement Parts Limited Warranty – covers all Honda replacement parts against defects in materials and workmanship.

Replacement Battery Limited Warranty – provides prorated coverage for a replacement battery purchased from your dealer.

Replacement Muffler Lifetime Limited Warranty – provides coverage for as long as the purchaser of the muffler owns the vehicle.

Restrictions and exclusions apply to all these warranties. Please read the 2006 Honda warranty information booklet that came with your vehicle for precise information on warranty coverages. Your vehicle’s original tires are covered by their manufacturer. Tire warranty information is in a separate booklet.

Canadian Owners
Please refer to the 2006 Warranty Manual that came with your vehicle.

Reporting Safety Defects (U.S. Vehicles)

If you believe that your vehicle has a defect which could cause a crash or could cause injury or death, you should immediately inform the National Highway Traffic Safety Administration (NHTSA) in addition to notifying American Honda Motor Co., Inc.

If NHTSA receives similar complaints, it may open an investigation, and if it finds that a safety defect exists in a group of vehicles, it may order a recall and remedy campaign. However, NHTSA cannot become involved in individual problems between you, your dealer, or American Honda Motor Co., Inc.

To contact NHTSA, call the Vehicle Safety Hotline toll-free at 1-800-327-4236 (TTY: 1-800-424-9153); go to www.safercar.gov; or write to: Administrator, NHTSA, 400 Seventh Street, SW., Washington, DC, 20590. You can also obtain other information about motor vehicle safety from www.safercar.gov.

Purchasing Factory Authorized Manuals (U.S. only)

The publications shown below can be purchased from Helm Incorporated. You can order in any of three ways:

- Detach and mail the order form on the right half of this page
- Call Helm Inc. at 1-800-782-4356 (credit card orders only)
- Go online at www.helminc.com

If you are interested in other years or models, contact Helm Inc. at 1-800-782-4356.

Publication Form Number	Form Description	Price Each*
61SCV04	2003 – 2006 Honda Element Service Manual	\$75.00
61SCV04EL	2003 – 2006 Honda Element Electrical Troubleshooting Manual	\$50.00
61SCV30	2003 – 2006 Honda Element Body Repair Manual	\$44.00
31SCV630	2006 Honda Element Owner's Manual	\$35.00
31SNA700	2006 Honda Element Navigation System Owner's Manual	\$29.00
31SCVM10	2006 Honda Element Honda Service History	\$12.00
31SCVQ30	2006 Honda Element Quick Start Guide	\$12.00
HON-R	Order Form for Previous Years- Indicate Year and Model Desired	FREE

* Prices are subject to change without notice and without incurring obligation.

Valid only for sales within the United States. Canadian owners should contact their authorized Honda dealer.

ORDER TOLL FREE: 1-800-782-4356 (NOTE: For Credit Card Holder Orders Only) Monday-Friday 8:00 A.M. — 6:00 P.M. EST MINIMUM CREDIT CARD PURCHASE \$10.00
--

OR

By completing this form you can order the materials desired. You can pay by check or money order, or charge to your credit card. Mail to Helm Incorporated at the address shown on the back of the order form.

2006 HONDA	PUBLICATION NUMBER	VEHICLE MODEL		Qty	Price Each*	Total Price
		Name	Year			
* Prices are subject to change without notice and without incurring obligation.					TOTAL MATERIAL	
					Mich. Purchases Add 6% Sales Tax	
Orders are mailed within 10 days. Please allow adequate time for delivery.					HANDLING CHARGE	\$6.95
					GRAND TOTAL	

Authorized Manuals

S H I P T O	NOTE: Dealers and Companies please provide dealer or company name, and also the name of the person to whose attention the shipment should be sent. For purchases outside U.S.A. please write to the address shown below for a quotation.	
	_____	_____
	Customer Name	Attention
	_____	_____
	Street Address – No P.O. Box Number	Apartment Number
_____	_____	
City	State & Zip Code	
Daytime Telephone Number () _____		

P A Y M E N T	<input type="checkbox"/> Check or money order enclosed payable to Helm Inc – U.S. funds only. Do not send cash.
	<input type="checkbox"/> Master Card <input type="checkbox"/> VISA <input type="checkbox"/> Check here if your billing address is different from the shipping address shown above.
	Account Number _____ Expiration: Mo. Yr.

	CUSTOMER SIGNATURE DATE

These Publications cannot be returned for credit without receiving advance authorization within 14 days of delivery. On returns, a restocking fee may be applied against the original order.

HELM P.O. BOX 07280-DETROIT, MICHIGAN 48207-1-800-782-4356

Service Manual:

This manual covers maintenance and recommended procedures for repair to engine and chassis components. It is written for the journeyman mechanic, but is simple enough for most mechanically-inclined owners to understand.

Electrical Troubleshooting Manual:

This manual complements the service manual by providing in-depth troubleshooting information for each electrical circuit in your vehicle.

Body Repair Manual:

This manual describes the procedures involved in the replacement of damaged body parts.

A

Accessories.....	130
ACCESSORY (Ignition Key Position)	69
Accessory Power Sockets.....	87
Additives, Engine Oil.....	171
Airbag (SRS)	11, 23
Airbags, Additional Information	23
Additional Safety Precautions....	29
Airbag Service.....	28
How the Side Airbag Off Indicator Works.....	28
How the SRS Indicator Works...	27
How Your Front Airbags Work.....	24
How Your Side Airbags Work....	26
SRS Components	23
Air Conditioning System.....	91
Usage.....	91
Air Pressure, Tires	188
Normal Driving	188
Antifreeze	173
Anti-lock Brakes (ABS) Indicator.....	55, 150
Operation.....	149

Anti-theft, Audio System.....	116
Anti-theft Steering Column Lock ..	69
Armrests, Front Seat.....	74
Audio System	94
Automatic Seat Belt Tensioners	21
Automatic Speed Control.....	120
Automatic Transmission.....	143
Capacity, Fluid	222
Checking Fluid Level.....	175
Shifting.....	143
Shift Lever Position Indicator ..	143
Shift Lever Positions	143
Shift Lock Release.....	146
Auxiliary Input Jack.....	112

B

Battery Charging System Indicator.....	54, 209
Jump Starting	205
Maintenance.....	193
Specifications	223
Before Driving	123
Belts, Seat.....	10, 20
Beverage Holders.....	87

Body Panels.....	178
Booster Seats	45
Brakes Anti-lock System (ABS).....	149
Break-in, New Linings	124
Bulb Replacement	182
Fluid	177
Parking.....	83
System Indicator.....	54, 211
Wear Indicators	149
Braking System.....	148
Break-in, New Vehicle	124
Brightness Control, Instruments...	63
Brights, Headlights	62
Bulb Replacement Back-up Lights	182
Brake Lights.....	182
Front Parking Lights.....	180
Front Side Marker Lights.....	181
Headlights	179
Specifications	223
Turn Signal Lights.....	180
Bulbs, Halogen.....	179
Bungee Cords.....	135

CONTINUED

Index

C

Capacities Chart.....	222
Carbon Monoxide Hazard	47
Carrying Cargo	132
CAUTION, Explanation of	ii
CD Care	113
CD Changer.....	112
CD Error Message	114
CD Changer Error Message	115
CD Player.....	106
Ceiling Pocket.....	86
Certification Label.....	220
Chains	192
Changing a Flat Tire	197
Changing Oil	171
How to.....	171
When to.....	165
Charging System Indicator	54, 209
Checklist, Before Driving.....	139
Child Safety	30
Child Seats	
LATCH Anchorage System	39
Lower Anchors	39
Tether Anchorage Points	43
Cleaning the Body Panels.....	178

Clock	117
Clock, Setting the	117
Clutch Fluid.....	177
CO in the Exhaust	227
Cold Weather, Starting in.....	140
Compact Spare	196
Consumer Information *	234
Controls, Instruments and.....	51
Coolant	
Adding.....	173
Checking.....	128
Proper Solution	173
Temperature Gauge	59
Crankcase Emissions Control	
System.....	227
Cruise Control Indicator	56
Cruise Control Operation	120
Customer Service Office	234

D

DANGER, Explanation of	ii
Dashboard	4, 52
Daytime Running Lights	
Indicator**	56
Dead Battery	205

Defects, Reporting Safety*	236
Defog and Defrost.....	93
Defogger, Rear Window	63
Defrosting the Windows.....	93
Dimensions.....	222
Dimming the Headlights	62
Dipstick	
Automatic Transmission.....	175
Engine Oil.....	128
Directional Signals.....	62
Disc Brake Wear Indicators.....	149
Disposal of Used Oil.....	172
Doors	
Locking and Unlocking.....	70
Power Door Locks.....	70
DOT Tire Quality Grading*	224
Downshifting, Manual	
Transmission.....	141
Driver and Passenger Safety.....	7
Driving	137
Economy	129
Driving Guidelines.....	138
Dust and Pollen Filter	185

E

Economy, Fuel	129
Emergencies on the Road.....	195
Battery, Jump Starting	205
Brake System Indicator	211
Changing a Flat Tire	197
Charging System Indicator	209
Checking the Fuses.....	212
Hazard Warning Flashers	63
Low Oil Pressure Indicator	209
Malfunction Indicator Lamp	210
Overheated Engine	207
Emergency Brake.....	83
Emergency Flashers	63
Emergency Towing	217
Emissions Controls.....	227
Emissions Testing, State	230
Engine	
Coolant Temperature Gauge	59
Engine Speed Limiter	142, 145
Malfunction Indicator	
Lamp	54, 210
Oil Pressure Indicator	54, 209
Oil, What Kind to Use	170
Overheating.....	207

Specifications	222
Starting.....	140
Evaporative Emissions Controls..	227
Exhaust Fumes	47
Expectant Mothers, Use of Seat	
Belts by	18

F

Fan, Interior.....	91
Features	89
Filling the Fuel Tank.....	126
Filters	
Dust and Pollen.....	185
Oil	171
Flashers, Hazard Warning.....	63
Flat Tire, Changing a	197
Fluids	
Automatic Transmission.....	175
Brake	177
Clutch.....	177
Manual Transmission	176
Power Steering.....	178
Windshield Washer	174
FM Stereo Radio	
Reception	98

Folding Rear Seat	77
Four-way Flashers	63
Four-wheel Drive	138
Front Airbags.....	11, 23
Front Seat	
Adjusting.....	12
Airbags.....	23
Fuel.....	124
Fill Door and Cap.....	126
Gauge	59
Octane Requirement.....	124
Reserve Indicator.....	56
Tank, Filling the.....	126
Fuses, Checking the.....	212

G

Gas Mileage, Improving.....	129
Gasoline	124
Fuel Reserve Indicator	56
Gauge	59
Octane Requirement	124
Tank, Filling the.....	126

CONTINUED

Index

Gas Station Procedures.....	126
Gauges	
Engine Coolant Temperature	59
Fuel.....	59
Gearshift Lever Positions	
Automatic Transmission.....	143
Manual Transmission	141
Glove Box	87

H

Halogen Headlight Bulbs.....	179
Hatch	71
Hazard Warning Flashers.....	63
Headlights	
Aiming	179
Daytime Running Lights**	62
High Beam Indicator	56
Reminder Beeper.....	62
Replacing Halogen Bulbs	179
Turning on.....	62
Head Restraints	75
Heating and Cooling.....	90
High Altitude, Starting at.....	140
High-Low Beam Switch	62
Hood, Opening and Closing the...	127

IV

Horn.....	5, 60
Hydraulic Clutch.....	177

I

Identification Number, Vehicle....	220
Ignition	
Keys.....	65
Switch.....	69
Timing Control System.....	228
Immobilizer System.....	66
Important Safety Precautions	8
Indicators, Instrument Panel.....	53
Infant Restraint	35
Infant Seats.....	35
LATCH Anchorage System	39
Lower Anchors	39
Tether Anchorage Points	43
Inflation, Proper Tire	187
Normal Driving	188
Inside Mirror	82
Inspection, Tire.....	189
Instrument Panel	53
Instrument Panel Brightness	63
Interior Lights	88
Introduction.....	i

J

Jacking up the Vehicle	199
Jack, Tire	197
Jump Starting	205

K

Keys.....	65
-----------	----

L

Label, Certification	220
Lane Change, Signaling	62
Lap/Shoulder Belts.....	15, 20
LATCH Anchorage System.....	39
Lights	
Bulb Replacement	179
Indicator	53
Parking	62
Turn Signal.....	62
Load Limits.....	133
LOCK (Ignition Key Position)	69
Locks	
Anti-theft Steering Column	69
Fuel Fill Door	126

Glove Box	87
Power Door	70
Tailgate	72
Low Coolant Level.....	128
Low Fuel Indicator	56
Low Oil Pressure Indicator	54, 209
Lower Anchors.....	39
Lower Gear, Downshifting to a.....	141
Lubricant Specifications Chart	222
Luggage	132

M

Maintenance.....	161
Owner Maintenance Checks....	164
Record.....	167-168
Required Indicator.....	57
Safety.....	162
Schedule	165-166
Malfunction Indicator Lamp ..	54, 210
Manual Transmission.....	141
Checking Fluid Level	176
Shifting the	141
Manual Transmission Fluid	176
Meters, Gauges.....	53, 58
Mirrors, Adjusting	82

Modifying Your Vehicle.....	131
-----------------------------	-----

N

Neutral Gear Position.....	144
New Vehicle Break-in	124
Normal Shift Speeds.....	142
NOTICE, Explanation of.....	i
Numbers, Identification.....	220

O

Octane Requirement, Gasoline....	124
Odometer.....	58
Odometer, Trip	58
Off-Highway Driving.....	157
Oil	
Change, How to	171
Change, When to	165
Checking Engine	128
Pressure Indicator	54, 209
Selecting Proper Viscosity	
Chart	170
ON (Ignition Key Position)	69
Onboard Refueling Vapor	
Recovery	227

Outside Mirrors	82
Overdrive	145
Overheating, Engine	207
Owner Maintenance Checks.....	164

P

Panel Brightness Control	63
Park Gear Position.....	143
Parking	147
Parking Brake	83
Parking Brake and Brake	
System Indicator	54, 211
Parking Lights.....	62
Parking Over Things that Burn...	147
Playing a Disc.....	106
Playing the AM/FM Radio.....	94
Playing the XM Satellite	
Radio	100
PGM-FI System.....	228
Power Socket Locations.....	87
Power Windows	81
Power Door Locks.....	70
Pregnancy, Using Seat Belts.....	18

CONTINUED

Index

Protecting Adults and Teens.....	12
Additional Safety Precautions....	19
Advice for Pregnant Women.....	18
Protecting Children.....	30
Protecting Infants and Small Children.....	35
Protecting Larger Children.....	44
Using Booster Seat.....	45

R

Radiator Overheating.....	207
Radio/CD Sound System.....	94
Readiness Codes.....	230
Rear Doors.....	70
Rear Lights, Bulb Replacement...	182
Rear Seat Access.....	75
Rear Seat, Folding.....	77
Rear View Mirror.....	82
Rear Window Defogger.....	63
Rear Window Wiper and Washer..	61
Reclining the Seat-Backs.....	73
Recommended Shift Speeds.....	142
Reminder Lights.....	53
Removing the Rear Seats.....	79
Remote Transmitter.....	67

Replacement Information	
Dust and Pollen Filter.....	185
Engine Oil and Filter.....	171
Fuses.....	212
Light Bulbs.....	179
Schedule.....	165
Tires.....	187
Wiper Blades.....	186
Replacing Seat Belts After a Crash.....	21
Reserve Tank, Engine Coolant.....	128, 173
Restraint, Child.....	30
Reverse Gear Position.....	144
Roof Rack.....	134
Rotation, Tire.....	190

S

Safety Belts.....	10, 20
Safety Defects, Reporting*.....	236
Safety Features.....	9
Airbags.....	11
Seat Belts.....	10
Safety Labels, Location of.....	48
Safety Messages.....	ii

Satellite Radio.....	100
Seat Belts.....	10, 20
Additional Information.....	20
Automatic Seat Belt Tensioners.....	21
Lap/Shoulder Belt.....	15, 20
Maintenance.....	21
Reminder Light.....	20, 54
System Components.....	20
Use During Pregnancy.....	18
Wearing a Lap/Shoulder Belt...	15
Seats, Adjusting the.....	73
Serial Number.....	220
Service Intervals.....	165
Service Manual*.....	237
Service Station Procedure.....	126
Setting the Clock.....	117
Shift Lever Position Indicator.....	143
Shift Lock Release.....	146
Side Airbags.....	26
Off Indicator.....	28
Side Marker Lights, Bulb Replacement.....	181
Signaling Turns.....	62
Skylight.....	83
Snow Tires.....	191

Sound System..... 94
Spare Tire 196
 Inflating..... 196
 Specifications 223
Specifications Charts..... 222
Speed Control..... 120
SRS, Additional Information..... 23
 Additional Safety Precautions... 29
 Airbag Service..... 28
 How the Side Airbag Off
 Indicator Works..... 28
 How the SRS Indicator Works... 27
 How Your Front Airbags
 Work..... 24
 How Your Side Airbags Work... 26
 SRS Components 23
SRS Indicator..... 27, 55
START (Ignition Key Position) 69
State Emissions Testing 230
Starting the Engine..... 140
 In Cold Weather at High
 Altitude 140
 With a Dead Battery 205
Steam Coming from Engine..... 207
Steering Wheel
 Adjustment 64

 Anti-theft Column Lock 69
Stereo Sound System 94
Storing Your Vehicle 194
Supplemental Restraint
 System..... 11, 23
 Servicing 28
SRS Indicator..... 27, 55
 System Components..... 23
Synthetic Oil..... 171

T

Tailgate
 Open Indicator 57
 Opening the 72
Taillights, Changing Bulbs 182
Taking Care of the Unexpected .. 195
Technical Descriptions
 DOT Tire Quality Grading 224
 Emissions Control Systems..... 227
 State Emissions Testing 230
 Three Way Catalytic
 Converter..... 229
Tire Labeling..... 226
Temperature Gauge..... 59
Tether Anchorage Points 43

Theft Protection..... 116
Three Way Catalytic Converter... 229
Tilt the Steering Wheel..... 64
Time, Setting the 117
Tire Chains 192
Tire, How to Change a Flat 197
Tire Information 224
Tires 187
 Air Pressure 188
 Checking Wear 189
 Compact Spare..... 196
 DOT Tire Quality Grading* 224
 Inflation..... 187
 Inspection 189
 Maintenance..... 189
 Replacing 190
 Rotating..... 190
 Snow 191
 Specifications 223
 Tire Chains..... 192
Tools, Tire Changing 197

CONTINUED

Index

Towing	
A Trailer.....	151
Emergency	217
Equipment And Accessories	153
Weight Limit	151
Trailer Loading	152
Trailer Towing Tips.....	155
Traction Devices.....	192
Transmission	
Checking Fluid Level,	
Automatic	175
Checking Fluid Level,	
Manual	176
Fluid Selection	175, 176
Identification Number.....	220
Shifting the Automatic.....	143
Shifting the Manual.....	141
Treadwear*	224
Trip Meter	58
Turn Signals	62

U

Unexpected, Taking Care	
of the	195
Uniform Tire Quality Grading* ...	224

Unleaded Gasoline.....	124
Used Oil, How to Dispose of	172

V

Vehicle Capacity Load	133
Vehicle Dimensions.....	222
Vehicle Identification Number....	220
Vehicle Storage.....	194
Ventilation.....	92
VIN	220
Viscosity, Oil.....	170

W

WARNING, Explanation of	ii
Warning Labels, Location of	48
Warranty Coverages*	235
Washers, Windshield	
Checking the Fluid Level	174
Operation	61
Wheels	
Adjusting the Steering	64
Alignment and Balance.....	189
Nut Wrench.....	198

Windows	
Operating the Power	81
Rear, Defogger	63
Windshield	
Cleaning	61
Defroster	93
Washers	174
Wipers, Windshield	
Changing Blades.....	186
Operation	61
Worn Tires	189
Wrecker, Emergency Towing.....	217

* : U.S. only

** : Canada only

Service Information Summary

Gasoline:

Unleaded gasoline, pump octane number of 87 or higher.

Fuel Tank Capacity:

15.9 US gal (60 ℓ)

Recommended Engine Oil:

API Premium grade 5W-20 detergent oil (see page [170](#)).

Oil change capacity (including filter):

4.4 US qt (4.2 ℓ)

Automatic Transmission Fluid:

Honda ATF-Z1 (Automatic Transmission Fluid) preferred, or a DEXRON® III ATF as a temporary replacement (see page [175](#)).

Manual Transmission Fluid:

Honda Manual Transmission Fluid preferred, or an SAE 10W-30 or 10W-40 motor oil as a temporary replacement (see page [176](#)).

Capacity (including differential):

2.0 US qt (1.9 ℓ)

Rear Differential Fluid:

Honda Dual Pump Fluid. Do not use ATF.

Capacity:

1.1 US qt (1.0 ℓ)

Power Steering Fluid:

Honda Power Steering Fluid preferred, or another brand of power steering fluid as a temporary replacement. Do not use ATF (see page [178](#)).

Brake Fluid:

Honda Heavy Duty Brake Fluid DOT 3 preferred, or a DOT 3 or DOT 4 brake fluid as a temporary replacement (see page [177](#)).

Tire Pressure (measured cold):

Front:

32 psi (220 kPa , 2.2 kgf/cm²)

Rear:

34 psi (235 kPa , 2.4 kgf/cm²)

Spare Tire Pressure:

60 psi (420 kPa , 4.2 kgf/cm²)