

## 2004 Pilot Online Reference Owner's Manual

Use these links (and links throughout this manual) to navigate through this reference.  
For a printed owner's manual, click on authorized manuals or go to [www.helminc.com](http://www.helminc.com).

## Contents

---

### Owner's Identification Form

<b>Introduction</b> .....	<b>i</b>
<b>A Few Words About Safety</b> .....	<b>ii</b>
<b>Your Vehicle at a Glance</b> .....	<b>2</b>
<b>Driver and Passenger Safety</b> .....	<b>5</b>
Proper use and care of your vehicle's seat belts, and Supplemental Restraint System.	
<b>Instruments and Controls</b> .....	<b>45</b>
Instrument panel indicator and gauge, and how to use dashboard and steering column controls.	
<b>Comfort and Convenience Features</b> .....	<b>81</b>
How to operate the climate control system, the audio system, and other convenience features.	
<b>Before Driving</b> .....	<b>123</b>
What gasoline to use, how to break-in your new vehicle, and how to load luggage and other cargo.	
<b>Driving</b> .....	<b>135</b>
The proper way to start the engine, shift the transmission, and park, plus towing a trailer.	
<b>Maintenance</b> .....	<b>159</b>
The Maintenance Schedule shows you when you need to take your vehicle to the dealer.	
<b>Taking Care of the Unexpected</b> .....	<b>195</b>
This section covers several problems motorists sometimes experience, and how to handle them.	
<b>Technical Information</b> .....	<b>215</b>
ID numbers, dimensions, capacities, and technical information.	
<b>Warranty and Customer Relations (U.S. and Canada)</b> .....	<b>229</b>
A summary of the warranties covering your new Honda, and how to contact us.	
<b>Index</b> .....	<b>I</b>

### Service Information Summary

A summary of information you need when you pull up to the fuel pump.

## Owner's Identification

---

OWNER \_\_\_\_\_  
\_\_\_\_\_

ADDRESS \_\_\_\_\_  
STREET

\_\_\_\_\_ CITY

STATE/PROVINCE

ZIP CODE/  
POSTAL CODE

V. I. N. \_\_\_\_\_

DELIVERY DATE \_\_\_\_\_  
(Date sold to original retail purchaser)

DEALER NAME \_\_\_\_\_ DEALER NO. \_\_\_\_\_

ADDRESS \_\_\_\_\_  
STREET

\_\_\_\_\_ CITY

STATE/PROVINCE

ZIP CODE/  
POSTAL CODE

OWNER'S SIGNATURE \_\_\_\_\_

DEALER'S SIGNATURE \_\_\_\_\_

This Owner's Manual should be considered a permanent part of the vehicle, and should remain with the vehicle when it is sold.

This Owner's Manual covers all models of the Pilot. You may find descriptions of equipment and features that are not on your particular model.

The information and specifications included in this publication were in effect at the time of approval for printing. Honda Motor Co., Ltd. reserves the right, however, to discontinue or change specifications or design at any time without notice and without incurring any obligation whatsoever.

**POUR CLIENTS CANADIEN  
AVIS IMPORTANT: Si vous avez  
besoin d'un Manuel du Conducteur  
en français, veuillez demander à  
votre concessionnaire de  
commander le numéro de pièce  
33S9VC10**

Congratulations! Your selection of a 2004 Honda Pilot was a wise investment. It will give you years of driving pleasure.

One of the best ways to enhance the enjoyment of your new Honda is to read this manual. In it, you will learn how to operate its driving controls and convenience items. Afterwards, keep this owner's manual in your vehicle so you can refer to it at any time.

Several warranties protect your new Honda. Read the warranty booklet thoroughly so you understand the coverages and are aware of your rights and responsibilities.

Maintaining your vehicle according to the schedules given in this manual helps to keep your driving trouble-free while it preserves your investment. When your vehicle needs maintenance, keep in mind that your Honda dealer's staff is specially trained in servicing the many systems unique to your Honda. Your Honda dealer is dedicated to your satisfaction and will be pleased to answer any questions and concerns.

### California Proposition 65 Warning

**WARNING:** This product contains or emits chemicals known to the State of California to cause cancer and birth defects or other reproductive harm.

As you read this manual, you will find information that is preceded by a **NOTICE** symbol. This information is intended to help you avoid damage to your Honda, other property, or the environment.

## A Few Words About Safety

---

Your safety, and the safety of others, is very important. And operating this car safely is an important responsibility.

To help you make informed decisions about safety, we have provided operating procedures and other information on labels and in this manual. This information alerts you to potential hazards that could hurt you or others.

Of course, it is not practical or possible to warn you about all the hazards associated with operating or maintaining your vehicle. You must use your own good judgement.

You will find this important safety information in a variety of forms, including:

- **Safety Labels** – on the vehicle.
- **Safety Messages** – preceded by a safety alert symbol  and one of three signal words: **DANGER**, **WARNING**, or **CAUTION**.  
These signal words mean:

 **DANGER**

You **WILL** be **KILLED** or **SERIOUSLY HURT** if you don't follow instructions.

 **WARNING**

You **CAN** be **KILLED** or **SERIOUSLY HURT** if you don't follow instructions.

 **CAUTION**

You **CAN** be **HURT** if you don't follow instructions.

- **Safety Headings** – such as Important Safety Reminders or Important Safety Precautions.
- **Safety Section** – such as Driver and Passenger Safety.
- **Instructions** – how to use this vehicle correctly and safely.

This entire book is filled with important safety information – please read it carefully.

## Important Handling Information

---

Your Pilot has higher ground clearance than a passenger vehicle designed for use only on pavement. Higher ground clearance has many advantages for off-highway driving. It allows you to travel over bumps, obstacles, and rough terrain. It also provides good visibility so you can anticipate problems earlier.

These advantages come at some cost. Because your vehicle is taller and rides higher off the ground, it has a high center of gravity. This means your vehicle can tip or roll over if you make abrupt turns. Utility vehicles have a significantly higher rollover rate than other types of vehicles. In a rollover crash, an unbelted person is significantly more likely to die than a person wearing a seat belt. As a reminder, make sure you and your passengers always wear seat belts.

For information on how to reduce the risk of rollover, read “Driving Guidelines” on page 136 of this manual and the *Off-Highway Guidelines* section on page 155 . Failure to operate this vehicle correctly may result in loss of control or an accident.

## Your Vehicle at a Glance

---

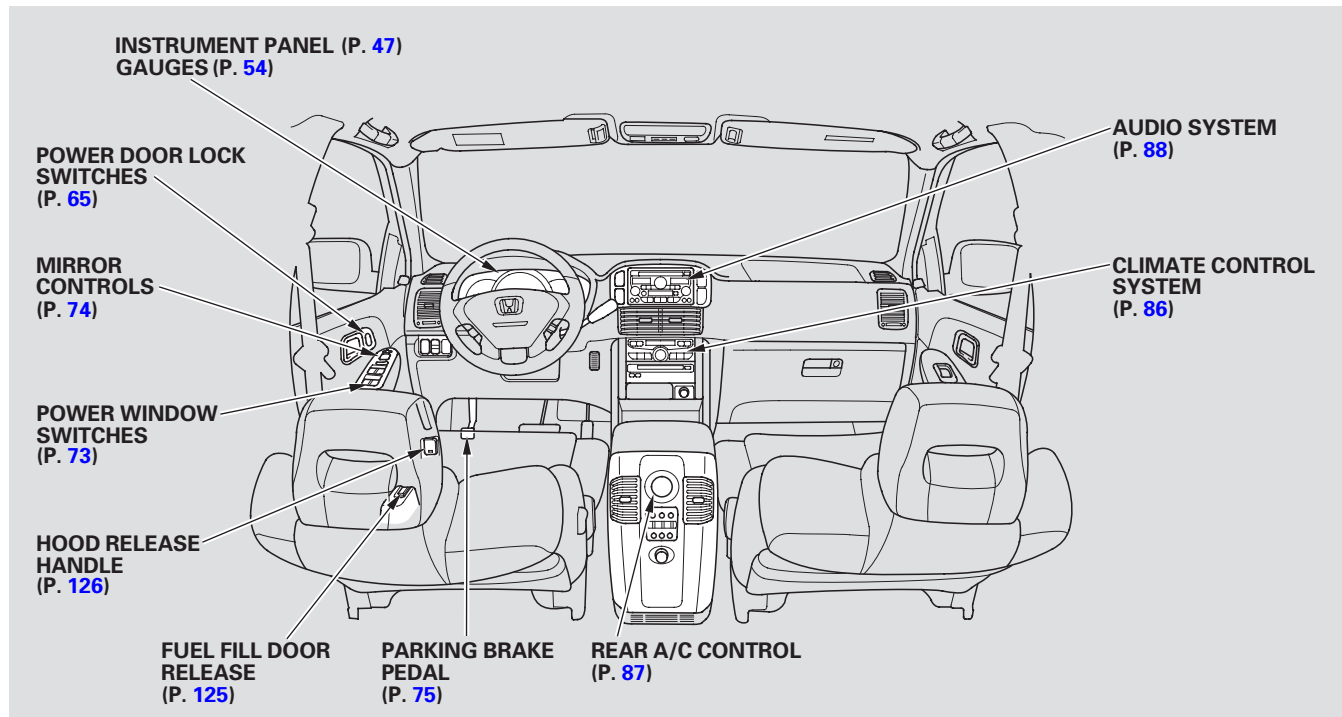

# Your Vehicle at a Glance

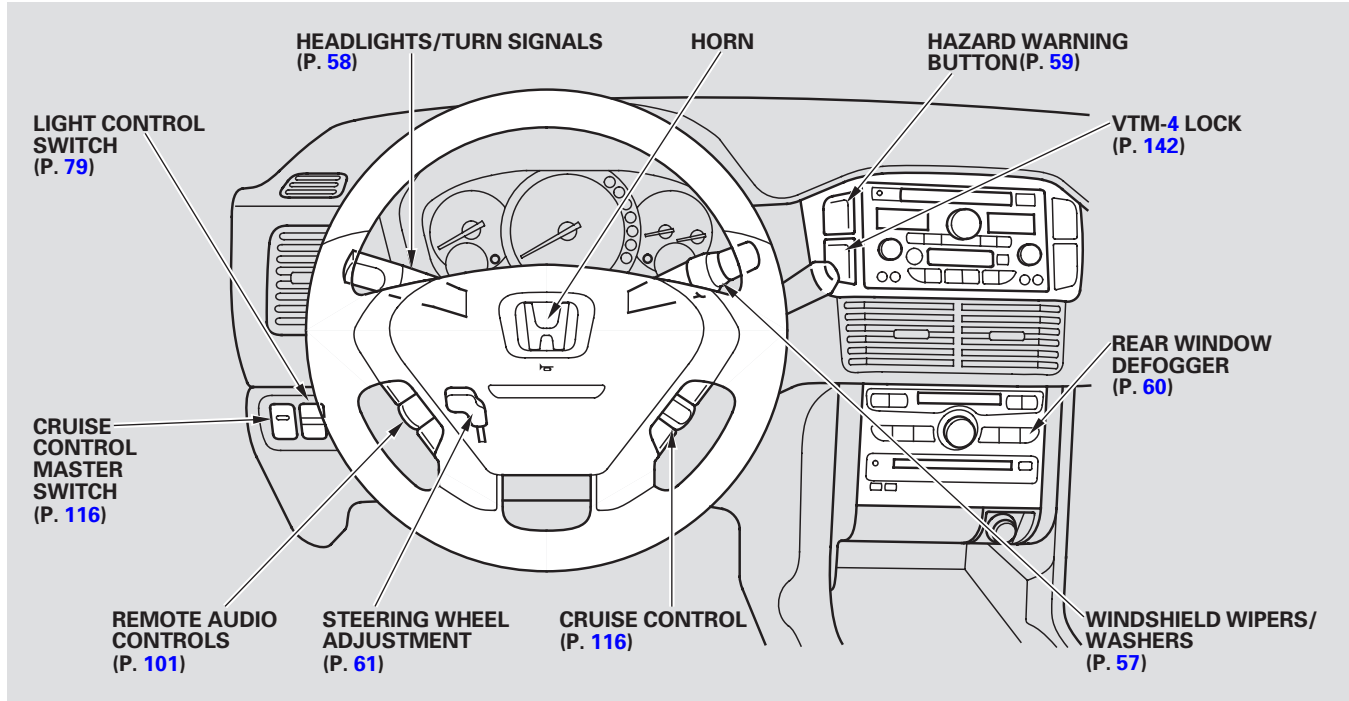





This section gives you important information about how to protect yourself and your passengers. It shows you how to use seat belts properly. It explains how your airbags work. And it tells you how to properly restrain infants and children in your vehicle.

Important Safety Precautions .....	6
Your Vehicle's Safety Features.....	7
Seat Belts .....	8
Airbags .....	9
Protecting Adults and Teens.....	10
1. Close and Lock the Doors .....	10
2. Adjust the Front Seats .....	10
3. Adjust the Seat-Backs .....	11
4. Adjust the Head Restraints ....	12
5. Fasten and Position the Lap/Shoulder Seat Belts ....	12
6. Adjust the Steering Wheel .....	14
7. Maintain a Proper Sitting Position .....	14

Advice for Pregnant Women.....	15
Additional Safety Precautions....	16
Additional Information About Your	
Seat Belts .....	17
Seat Belt System Components...	17
Lap/Shoulder Belt .....	17
Automatic Seat Belt Tensioners.....	18
Seat Belt Maintenance .....	19
Additional Information About	
Your Airbags .....	19
Airbag System Components.....	19
How Your Front Airbags Work.....	20
How Your Side Airbags Work....	22
How the SRS Indicator Light Works.....	23
How The Side Airbag Off Indicator Works .....	23
Airbag Service .....	24
Additional Safety Precautions....	24
Protecting Children — — General	
Guidelines.....	25
All Children Must Be Restrained .....	25

All Children Should Sit in the Back Seat .....	26
The Passenger's Front Airbag Can Pose Serious Risks .....	26
If You Must Drive with Several Children .....	28
If a Child Requires Close Attention .....	28
Additional Safety Precautions....	28
Protecting Infants .....	29
Protecting Small Children .....	30
Selecting a Child Seat.....	31
Installing a Child Seat .....	32
Installing a Child Seat Using LATCH.....	33
Installing a Child Seat with a Lap/shoulder Belt .....	35
Installing a Child Seat with a Tether .....	37
Protecting Larger Children .....	38
Checking Seat Belt Fit .....	39
Using a Booster Seat.....	39
Additional Safety Precautions....	41
Carbon Monoxide Hazard .....	42
Safety Labels .....	43

## Important Safety Precautions

---

You'll find many safety recommendations throughout this section, and throughout this manual. The recommendations on this page are the ones we consider to be the most important.

### **Always Wear Your Seat Belt**

A seat belt is your best protection in all types of collisions. Airbags supplement seat belts, but airbags are designed to inflate only in a moderate to severe frontal or side collision. So even though your vehicle is equipped with airbags, make sure you and your passengers always wear your seat belts, and wear them properly (see page 12 ).

### **Restrain All Children**

Children age 12 and under should ride properly restrained in a back seat. Infants and small children should be restrained in a child seat. Larger children should use a booster and a lap/shoulder belt until they

can use the belt properly without a booster (see page 25 ).

### **Be Aware of Airbag Hazards**

While airbags can save lives, they can cause serious or fatal injuries to occupants who sit too close to them, or are not properly restrained. Infants, young children, and short adults are at the greatest risk. Be sure to follow all instructions and warnings in this manual (see page 9 ).

### **Don't Drink and Drive**

Alcohol and driving don't mix. Even one drink can reduce your ability to respond to changing conditions, and your reaction time gets worse with every additional drink. So don't drink and drive, and don't let your friends drink and drive, either.

### **Control Your Speed**

Excessive speed is a major factor in crash injuries and deaths. Generally, the higher the speed, the greater the risk, but serious injuries can also occur at lower speeds. Never drive faster than is safe for current conditions, regardless of the maximum speed posted.

### **Keep Your Vehicle in Safe Condition**

Having a tire blowout or a mechanical failure can be extremely hazardous. To reduce the possibility of such problems, check your tire pressures and condition frequently, and perform all regularly scheduled maintenance (see page 161 ).

## Your Vehicle's Safety Features

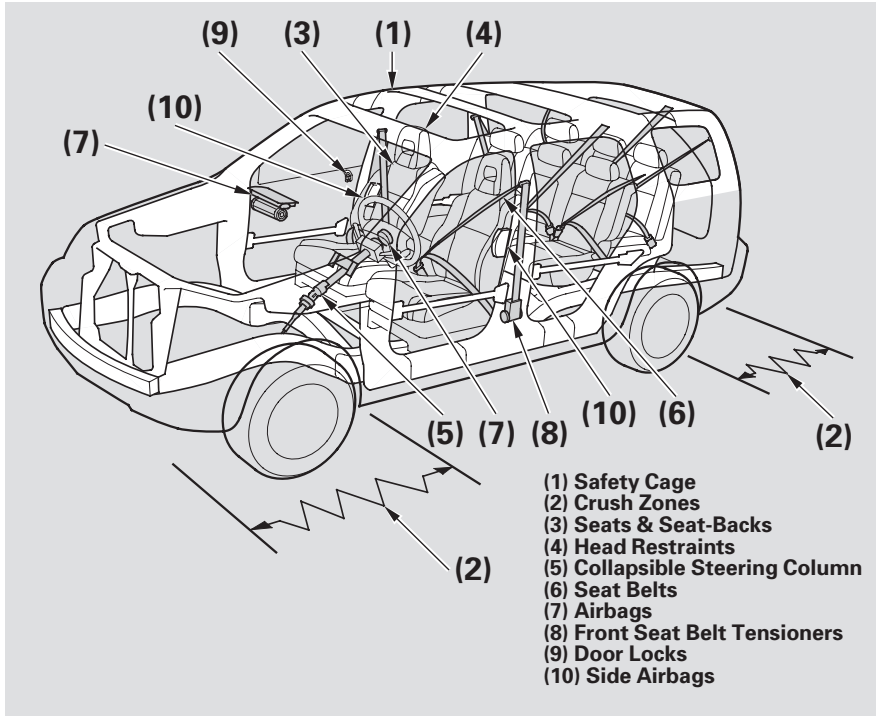

Your vehicle is equipped with many features that work together to protect you and your passengers during a crash. Some safety features do not require any action on your part. These include a strong steel framework that forms a safety cage around the passenger compartment; front and rear crush zones, a collapsible steering column, and seat belt tensioners that tighten the front seat belts in the event of a crash. However, you and your passengers can't take full advantage of these safety features unless you remain sitting in a proper position and always wear your seat belts properly. In fact, some safety features can contribute to injuries if they are not used properly. The following pages explain how you can take an active role in protecting yourself and your passengers.

*CONTINUED*

## Your Vehicle's Safety Features

---

### Seat Belts

Your vehicle is equipped with seat belts in all seating positions.

Your seat belt system also includes an indicator on the instrument panel to remind you and your passengers to fasten your seat belts.

### *Why Wear Seat Belts*

Seat belts are the single most effective safety device for adults and larger children (Infants and smaller children must be properly restrained in child seats).

Not wearing a seat belt properly increases the chance of serious injury or death in a crash, even though your vehicle has airbags.

In addition, most states and all Canadian provinces require you to wear seat belts.

When properly worn, seat belts:

- Keep you connected to the vehicle so you can take advantage of the vehicle's built-in safety features.
- Help protect you in almost every type of crash, including frontal, side, and rear impacts and rollovers.
- Help keep you from being thrown against the inside of the vehicle and against other occupants.
- Keep you from being thrown out of the vehicle.
- Help keep you in a good position should the airbags ever deploy. A good position reduces the risk of injury from an inflating airbag, and allows you to get the best advantage from the airbag.

Of course, seat belts cannot completely protect you in every crash. But in most cases, seat belts can reduce your risk of serious injury.

### *What You Should Do:*

Always wear your seat belt, and make sure you wear it properly.

The rest of this section gives more detailed information about how you can take an active role in maximizing your safety.

### **WARNING**

Not wearing a seat belt properly increases the chance of serious injury or death in a crash, even if you have airbags.

Be sure you and your passengers always wear seat belts and wear them properly.

### Airbags

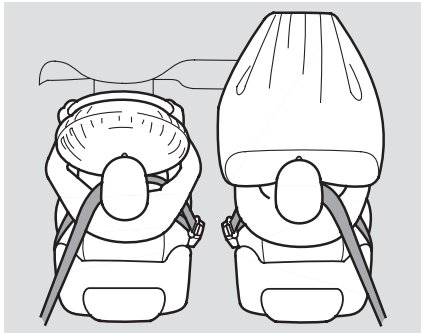

Your vehicle has a Supplemental Restraint System (SRS) with front airbags to help protect the heads and chests of the driver and a front seat passenger during a moderate to severe frontal collision (see page 20 for more information on how your front airbags work).

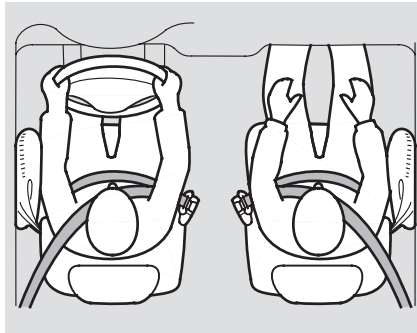

Your vehicle also has side airbags to help protect the upper torso of the driver or a front seat passenger during a moderate to severe side impact. (See page 22 for more information on how your side airbags work.)

The most important things you need to know about your airbags are:

- **Airbags do not replace seat belts.** They are designed to supplement the seat belts.
- **Airbags offer no protection in rear impacts, or minor frontal or side collisions.**
- **Airbags can pose hazards.** To do their job, airbags must inflate with tremendous force. So while airbags help save lives, they can cause minor injuries or more serious or even fatal injuries if occupants are not properly restrained or sitting properly.

**What you should do:** Always wear your seat belt properly, and sit upright, and as far back from the steering wheel while allowing full control of the vehicle. A front passenger should move their seat as far back from the dashboard as possible.

## Protecting Adults and Teens

---

The rest of this section gives more detailed information about how you can maximize your safety.

Remember however, that no safety system can prevent all injuries or deaths that can occur in severe crashes, even where seat belts are properly worn and the airbags deploy.

The following pages provide instructions on how to properly protect the driver, adult passengers and teenage children who are large enough and mature enough to ride in the front seat.

See page [26](#) for important guidelines on how to properly protect infants, small children, and larger children who ride in your vehicle.

### 1. Close and Lock the Doors

After everyone has entered the vehicle, be sure the doors and tailgate are closed and locked.

Your vehicle has a door and tailgate monitor indicator on the instrument panel to indicate when a specific door or the tailgate is not tightly closed.

Locking the doors reduces the chance of someone being thrown out of the vehicle during a crash, and it helps prevent passengers from accidentally opening a door and falling out.

Locking the doors also helps prevent an outsider from unexpectedly opening a door when you come to a stop.

See page [65](#) for how to lock the doors, and page [50](#) for how the monitor light works.

### 2. Adjust the Front Seats

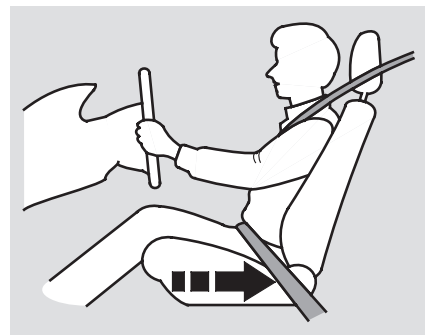

Adjust the driver's seat as far to the rear as possible while allowing you to maintain full control of the vehicle. Have a front passenger adjust their seat as far to the rear as possible.

If you sit too close to the steering wheel or dashboard, you can be seriously injured by an inflating front airbag, or by striking the steering wheel or dashboard.

The National Highway Traffic Safety Administration and Transport Canada recommend that drivers allow at least 10 inches (25 cm) between the center of the steering wheel and the chest.

If you cannot get far enough away from the steering wheel and still reach the controls, we recommend that you investigate whether some type of adaptive equipment may help. Once your seat is adjusted correctly, rock it back and forth to make sure the seat is locked into position. See page 68 for how to adjust the front seats.

### **⚠ WARNING**

Sitting too close to a front airbag can result in serious injury or death if the front airbags inflate.

Always sit as far back from the front airbags as possible.

### 3. Adjust the Seat-Backs

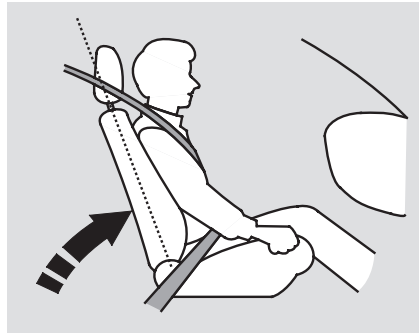

Adjust the driver's seat-back to a comfortable, upright position, leaving ample space between your chest and the airbag cover in the center of the steering wheel.

Passengers with adjustable seat-backs should also adjust their seat-back to a comfortable, upright position.

Reclining a seat-back so that the shoulder part of the belt no longer rests against the occupant's chest reduces the protective capability of the belt. It also increases the chance of sliding under the belt in a crash and being seriously injured. The farther a seat-back is reclined, the greater the risk of injury.

See page 68 for how to adjust seat-backs.

### **⚠ WARNING**

Reclining the seat-back too far can result in serious injury or death in a crash.

Adjust the seat-back to an upright position, and sit well back in the seat.

## Protecting Adults and Teens

### 4. Adjust the Head Restraints

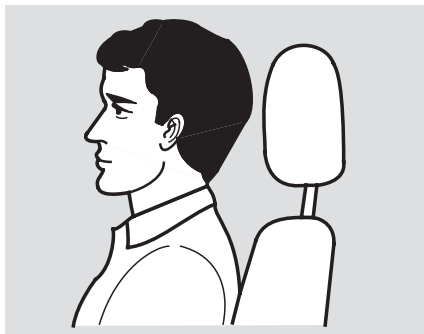

Adjust the driver's head restraint so the back of your head rests against the center of the restraint.

Have passengers with adjustable restraints adjust their restraints properly as well. Taller persons should adjust their restraint as high as possible.

### **⚠ WARNING**

Improperly positioning head restraints reduces their effectiveness and you can be seriously injured in a crash.

Make sure head restraints are in place and positioned properly before driving.

Properly adjusted head restraints will help protect occupants from whiplash and other crash injuries.

See page [72](#) for how to adjust the head restraints.

### 5. Fasten and Position the Lap/Shoulder Seat Belts

Insert the latch plate into the buckle, then tug on the belt to make sure the belt is securely latched. Also check that the belt is not twisted, because a twisted belt can cause serious injuries in a crash.

In the second row center seat and the third row seats, be sure the detachable anchors are also latched (see page [72](#)).

Position the lap part of the belt as low as possible across your hips, then pull up on the shoulder part of the belt so the lap part fits snugly. This lets your strong pelvic bones take the force of a crash and reduces the chance of internal injuries.





If necessary, pull up on the belt again to remove any slack, then check that the belt rests across the center of your chest and over your shoulder. This spreads the forces of a crash over the strongest bones in your upper body.

If the seat belt touches or crosses your neck, or if it crosses your arm instead of your shoulder, you need to adjust the seat belt anchor height.

To adjust the height of a front seat belt anchor, press and hold the release buttons and slide the anchor up or down as needed (it has four positions).

*Never place the shoulder portion of a lap/shoulder belt under your arm or behind your back.* This could cause very serious injuries in a crash.

### **⚠ WARNING**

Improperly positioning the seat belts can cause serious injury or death in a crash.

Make sure all seat belts are properly positioned before driving.

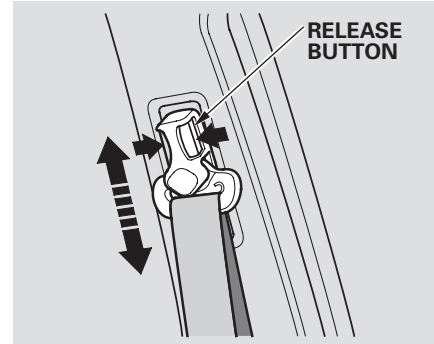

If a seat belt does not seem to work as it should, it may not protect the occupant in a crash.

*No one should sit in a seat with an inoperative seat belt.* Using a seat belt that is not working properly can result in serious injury or death. Have your Honda dealer check the belt as soon as possible.

CONTINUED

## Protecting Adults and Teens

---

*Never place the shoulder portion of a lap/shoulder belt under your arm or behind your back.* This could cause very serious injuries in a crash.

See page [17](#) for additional information about your seat belts and how to take care of them.

### 6. Adjust the Steering Wheel

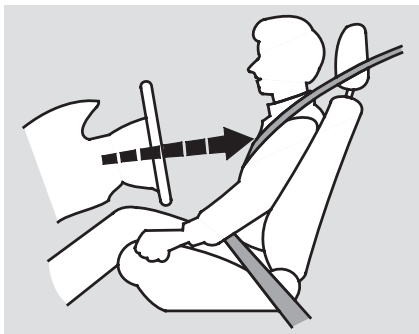

Adjust the steering wheel, if needed, so that the wheel points toward your chest, not toward your face. This provides optimal protection from the front airbag.

See page [61](#) for how to adjust the steering wheel.

### 7. Maintain a Proper Sitting Position

After all occupants have adjusted their seats and put on seat belts, it is very important that they continue to sit upright, well back in their seats, with their feet on the floor, until the vehicle is parked and the engine is off.

Sitting improperly can increase the chance of injury during a crash. For example, if an occupant slouches, lies down, turns sideways, sits forward, leans forward or sideways, or puts one or both feet up, the chance of injury during a crash is greatly increased.

In addition, an occupant who is out of position in the front seat can be seriously or fatally injured in a crash by striking interior parts of the vehicle or being struck by an inflating front airbag. Being struck by an inflating side airbag can possibly result in serious injuries.

### **⚠ WARNING**

Sitting improperly or out of position can result in serious injury or death.

Always sit upright, well back in the seat, with your feet on the floor.

### **Advice for Pregnant Women**



If you are pregnant, the best way to protect yourself and your unborn child when driving or riding in a vehicle is to always wear a seat belt, and keep the lap part of the belt as low as possible across the hips.

When driving, remember to sit upright and adjust the seat as far back as possible while allowing full control of the vehicle. When riding as a front passenger, adjust the seat as far back as possible.

This will reduce the risk of injuries to both you and your unborn child that can be caused by a crash or an inflating front airbag.

Each time you have a check-up, ask your doctor if it's okay for you to drive.

## Protecting Adults and Teens

---

### Additional Safety Precautions

- **Never let passengers ride in the cargo area or on top of a folded-down back seat.** All passengers must sit in locked, upright seats and be properly restrained by seat belts.
- **Passengers should not stand up or change seats while the vehicle is moving.** A passenger who is not wearing a seat belt during a crash or emergency stop can be thrown against the inside of the vehicle, against other occupants, or out of the vehicle.
- **Two people should never use the same seat belt.** If they do, they could be very seriously injured in a crash.
- **Do not put any accessories on seat belts.** Devices intended to improve occupant comfort or reposition the shoulder part of a seat belt can

reduce the protective capability of the seat belt and increase the chance of serious injury in a crash.

- **Do not place hard or sharp objects between yourself and a front airbag.** Carrying hard or sharp objects on your lap, or driving with a pipe or other sharp objects in your mouth, can result in injuries if your front airbag inflates.
- **Keep your hands and arms away from the airbag covers.** If your hands or arms are close to an airbag cover, they could be injured if the airbag inflates.
- **Do not attach or place objects on the front airbag covers.** Objects on the covers marked “SRS AIRBAG” could interfere with the proper operation of the airbags or if be propelled inside the vehicle and hurt someone if the airbags inflate.

- **Do not attach hard objects on or near a front door.** If a side airbag inflates, a cup holder or other hard object attached on or near the door could be propelled inside the vehicle and hurt someone.

## Additional Information About Your Seat Belts

### Seat Belt System Components

Your seat belt system includes lap/shoulder belts in all eight seating positions. The front seat belts are also equipped with automatic seat belt tensioners.



The seat belt system includes an indicator on the instrument panel and a beeper to remind you and your passengers to fasten your seat belts.

If you turn the ignition switch to ON (II) before fastening your seat belt, the beeper sounds and the indicator flashes. If you do not fasten your seat belt before the beeper stops, the indicator stops flashing but remains on.

If you continue driving without fastening your seat belt, the beeper sounds and the indicator flashes again at regular intervals.

### Lap/Shoulder Belt

The lap/shoulder belt in the center seat of the second and third row seats is equipped with a detachable anchor that has two parts: a small latch plate and a buckle.

The detachable anchor should normally be latched whenever the seats-backs are in an upright position. For more information about the detachable anchor (see page 72 ).

The lap and shoulder belt goes over your shoulder, across your chest, and across your hips.

To fasten the belt, insert the latch plate into the buckle, then tug on the belt to make sure the buckle is latched (see page 12 for how to properly position the belt).

To unlock the belt, push the red PRESS button on the buckle. Guide the belt across your body so that it retracts completely. After exiting the vehicle, be sure the belt is out of the way and will not get closed in the door.

All seat belts have an emergency locking retractor. In normal driving, the retractor lets you move freely in your seat while it keeps some tension on the belt. During a collision or sudden stop, the retractor automatically locks the belt to help restrain your body.

The seat belts in all positions except the driver's have an additional locking mechanism that must be activated to secure a child seat (see page 35).

## Additional Information About Your Seat Belts

---

If the shoulder part of the belt is pulled all the way out, the locking mechanism will activate. The belt will retract, but it will not allow the passenger to move freely.

To deactivate the locking mechanism, unlatch the buckle, and let the seat belt fully retract. To refasten the belt, pull it out only as far as needed.

To unlatch the belt, push the red **PRESS** button on the buckle.

### Automatic Seat Belt Tensioners

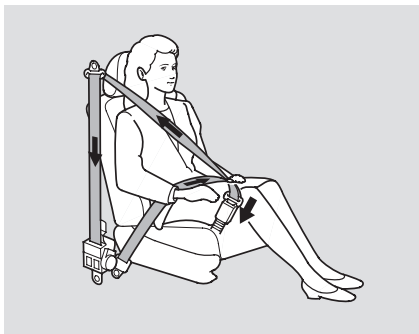

For added protection, the front seat belts are equipped with automatic seat belt tensioners. When activated, the tensioners immediately tighten the belts to help hold the driver and a front passenger in place.

The tensioners are designed to activate primarily in frontal collisions, and they should activate in any collision severe enough to cause front-airbag inflation.

However, the tensioners can be activated during a collision in which the front airbags do not deploy. In this case, the airbags would not be needed, but the additional restraint could be helpful.

When the tensioners are activated, the seat belts will remain tight until they are unbuckled in the normal manner.

## Additional Information About Your Seat Belts, Additional Information About Your Airbags

### Seat Belt Maintenance

For safety, you should check the condition of your seat belts regularly.

Pull each belt out fully and look for frays, cuts, burns, and wear. Check that the latches work smoothly and the belts retract easily. Any belt that is not in good condition or not working properly will not provide good protection and should be replaced as soon as possible.

Honda provides a lifetime warranty on seat belts for U.S. models. See your *Honda Warranty Information* booklet for details.

If a seat belt is worn during a crash, it must be replaced by the dealer. A belt that has been worn during a crash may not provide the same level of protection in a subsequent crash.

The dealer should also inspect the anchors for damage and replace them if needed. If the automatic seat belt tensioners activate during a crash, they must be replaced.

For information on how to clean your seat belts, see page [184](#).

### **WARNING**

Not checking or maintaining seat belts can result in serious injury or death if the seat belts do not work properly when needed.

Check your seat belts regularly and have any problem corrected as soon as possible.

### Airbag System Components

Your airbag system includes:

- Two SRS (Supplemental Restraint System) front airbags. The driver's airbag is stored in the center of the steering wheel; the front passenger's airbag is stored in the dashboard. Both are marked "SRS AIRBAG."
- Two side airbags, one for the driver and one for a front passenger. The airbags are stored in the outer edges of the seat-backs. Both are marked "SIDE AIRBAG" (see page [22](#)).
- Automatic front seat belt tensioners (see page [18](#)).
- Sensors that can detect a moderate to severe frontal or side collision.

## Additional Information About Your Airbags

---

- A sophisticated electronic system that continually monitors and records information about the sensors, the control unit, the airbag activators, and driver and front passenger seat belt use when the ignition is in the ON (II) position.
- An indicator on the instrument panel that alerts you to a possible problem with your airbags (see page 23).
- An indicator on the dashboard that alerts you that the passenger's front airbag has been turned off (see page 18).
- Emergency backup power in case your vehicle's electrical system is disconnected in a crash.

### How Your Front Airbags Work

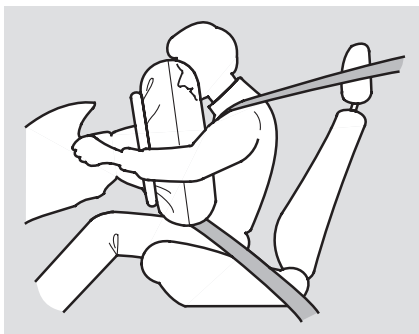

If you ever have a moderate to severe frontal collision, sensors will detect the vehicle's rapid deceleration. If the rate of deceleration is high enough, the control unit will instantly inflate the driver's and front passenger's front airbags, at the time and with the force needed.

During a frontal crash, your seat belt restrains your lower body and torso, and the airbag helps protect your head and chest.

Although both airbags normally inflate within a split second of each other, it is possible for only one airbag to deploy.

This can happen if the severity of a collision is at the margin, or threshold, that determines whether or not the airbags will deploy. In such cases, the seat belt will provide sufficient protection, and the supplemental protection offered by the airbag would be minimal.



## Additional Information About Your Airbags

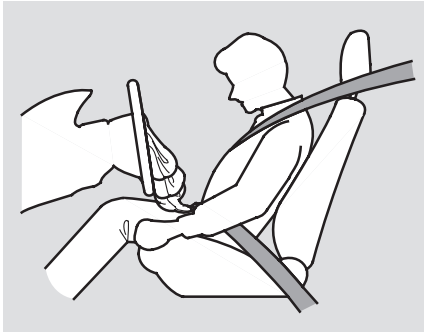

After inflating, the front airbags immediately deflate, so they won't interfere with the driver's visibility, or the ability to steer or operate other controls.

The total time for inflation and deflation is one-tenth of a second, so fast that most occupants are not aware that the airbags deployed until they see them lying in their laps.

After a crash, you may see what looks like smoke. This is actually powder from the airbag's surface. Although the powder is not harmful, people with respiratory problems may experience some temporary discomfort. If this occurs, get out of the vehicle as soon as it is safe to do so.

### *Dual-Stage Airbags*

Your front airbags are dual-stage airbags. This means they have two inflation stages that can be ignited sequentially or simultaneously, depending on crash severity.

In a **more severe** crash, both stages will ignite simultaneously to provide the quickest and greatest protection.

In a **less severe** crash, one stage will ignite first, then the second stage will ignite a split second later. This provides longer airbag inflation time with a little less force.

### *Dual-Threshold Airbags*

Your front airbags are also dual-threshold airbags. Airbags with this feature have two deployment thresholds that depend on whether or not the occupant is wearing a seat belt.

If the occupant's belt is **not latched**, the airbag will deploy at the same threshold as a conventional airbag, because the occupant would need extra protection.

If the occupant's belt **is latched**, the airbag will inflate at a slightly higher threshold, when the airbag would be needed to supplement the protection provided by the seat belt.

## Additional Information About Your Airbags

---

### How Your Side Airbags Work



If you ever have a moderate to severe side impact, the sensors will detect rapid deceleration and signal the control unit to instantly inflate either the driver's or the passenger's side airbag.

Only one airbag will deploy during a side impact. If the impact is on the passenger's side, the passenger's side airbag will deploy even if there is no passenger.

The passenger's side airbag has a cutoff system designed to turn off the passenger's side airbag if a child's head is in the airbag's deployment path (see page 23).

There will be some delay between the moment the passenger moves into or out of the airbag deployment path and when the indicator comes on or goes off.

If the side airbag cutoff indicator comes on, have the passenger sit upright. Once the passenger is out of the deployment path of the side airbag, the system will turn the airbag back on and the indicator will go out.

A front seat passenger should not use a cushion or other object as a backrest. It may prevent the cutoff system from working properly.

When you turn the ignition ON (II), the indicator should light briefly and go out (see page 23). If it doesn't light, stays on, or comes on while driving without a passenger in the front seat, have the system checked.

### How the SRS Indicator Works

**SRS** The SRS indicator alerts you to a potential problem with your front airbags, side airbags, or front seat belt tensioners (see page 48).

When you turn the ignition to ON (II), this indicator will light briefly then go out. This tells you that the system is working properly.

If the indicator comes on at any other time, or does not come on at all, you should have the system checked by your dealer. For example:

- If the SRS indicator does not come on after you turn the ignition switch to ON (II).
- If the indicator stays on after the engine starts.
- If the indicator comes on or flashes on and off while you drive.

If you see any of these indications, the airbags and seat belt tensioners may not work properly when you need them.

### **WARNING**

Ignoring the SRS indicator light can result in serious injury or death if the airbag systems, or tensioners do not work properly.

Have your vehicle checked by a dealer as soon as possible if the SRS indicator alerts you to a possible problem.

### How the Side Airbag Off Indicator Works

**SIDE AIRBAG OFF** This indicator alerts you that the passenger's side airbag has been automatically shut off. It does *not* mean there is a problem with your side airbags.

To reduce the risk of injury from an inflating side airbag, your vehicle has an automatic cutoff system for the passenger's side airbag.

Although Honda does not encourage children to ride in front, this system is designed to shut off the side airbag if a child leans sideways and the child's head is in the side airbag deployment path.

If a short adult leans sideways, or a larger adult slouches and leans sideways into the side airbag deployment path, the system may also shut off the side airbag.

## Additional Information About Your Airbags

---

Objects placed on the front passenger seat can also cause the side airbag to shut off.

To get the best protection from the side airbags, front seat occupants should wear their seat belts and sit upright and well back in their seats.

### Airbag Service

Your airbag systems are virtually maintenance-free, and there are no parts you can safely service. However, you must have your vehicle serviced if:

- ***An airbag ever inflates.*** Any airbag that has deployed must be replaced along with the control unit and other related parts. If a front airbag inflates the seat belt tensioners must also be replaced. Do not try to remove or replace any airbag by yourself. This must be done by a Honda dealer or a knowledgeable body shop.
- ***The SRS indicator light alerts you to a problem.*** Take your vehicle to an authorized Honda dealer as soon as possible. If you ignore this indication, your airbags may not operate properly.

### Additional Safety Precautions

- ***Do not attempt to deactivate your airbags.*** Together, airbags and seat belts provide the best protection.
- ***Do not tamper with airbag components or wiring for any reason.*** Tampering could cause the airbags to deploy, possibly causing very serious injury.
- ***Do not expose the front seat-backs to liquid.*** If water or another liquid soaks into a seat-back, it can prevent the side airbag cutoff system from working properly.
- ***Do not cover or replace front seat-back covers without consulting a Honda dealer.*** Improperly replacing or covering front seat-back covers can prevent your side airbags from inflating during a side impact.

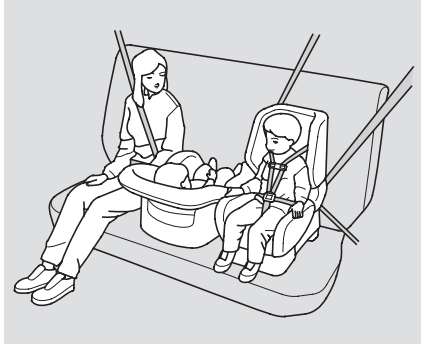

Children depend on adults to protect them. However, despite their best intentions many adults do not know how to properly protect child passengers.

### **⚠ WARNING**

Children who are unrestrained or improperly restrained can be seriously injured or killed in a crash.

Any child too small for a seat belt should be properly restrained in a child seat. A larger child should be properly restrained with a seat belt and use a booster if necessary.

If you have children, or if you ever need to drive with a child in your vehicle, be sure to read this section. It begins with important general guidelines, then presents special information for infants, small children, and larger children.

**All Children Must Be Restrained**  
Each year, many children are injured or killed in vehicle crashes because they are either unrestrained or not properly restrained. In fact, vehicle accidents are the number one cause of death of children ages 12 and under.

To reduce the number of child deaths and injuries, every state and Canadian province requires that infants and children be properly restrained when they ride in a vehicle.

## Protecting Children – General Guidelines

---

*Infants and small children must be restrained in an approved child seat that is properly secured to the vehicle* (see pages 29 – 31 ).

*Larger children must be restrained with a lap/shoulder belt and ride on a booster until the seat belt fits them properly* (see pages 38 – 41 ).

### All Children Should Sit in the Back Seat

According to accident statistics, children of all ages and sizes are safer when they are restrained in the back seat. The National Highway Traffic Safety Administration and Transport Canada recommend that all children age 12 and under be properly restrained in the back seat.

Children who ride in back are less likely to be injured by striking interior vehicle parts during a collision or hard braking. Also, children cannot be injured by an

inflating airbag when they ride in the back.

### The Passenger's Front Airbag Can Pose Serious Risks

Front airbags have been designed to help protect adults in a moderate to severe frontal collision. To do this the passenger's front airbag is quite large and it can inflate with enough force to cause very serious injuries.

#### *Infants*

*Never put a rear-facing child seat in the front seat of a vehicle equipped with a passenger's front airbag.* If the airbag inflates, it can hit the back of the child seat with enough force to kill or very seriously injure an infant.

#### *Small Children*

*Placing a forward-facing child seat in the front seat of a vehicle equipped with passenger's front airbag can be hazardous.* If the vehicle seat is too far forward, or the child's head is thrown forward during a collision, an inflating front airbag can strike the child with enough force to kill or very seriously injure a small child.

#### *Larger Children*

*Children who have outgrown child seats are also at risk of being injured or killed by an inflating passenger's front airbag.* Whenever possible, larger children should sit in the back seat, in a booster seat if needed, and be properly restrained with a seat belt (see page 38 for important information about protecting larger children).

## U.S. Models

To remind you of the passenger's front airbag hazards, and that children must be properly restrained in the back seat, your vehicle has warning labels on the dashboard and on the driver's and front passenger's visors. Please read and follow the instructions on these labels.

<b>⚠ WARNING</b>	
	<p>DEATH or SERIOUS INJURY can occur</p> <ul style="list-style-type: none"><li>• Children 12 and under can be killed by the air bag</li><li>• The BACK SEAT is the SAFEST place for children</li><li>• NEVER put a rear-facing child seat in the front</li><li>• Sit as far back as possible from the air bag</li><li>• ALWAYS use SEAT BELTS and CHILD RESTRAINTS</li></ul>

<b>⚠ WARNING</b>	
<b>Children Can Be KILLED or INJURED by Passenger Air Bag</b>	
<ul style="list-style-type: none"><li>• The back seat is the safest place for children 12 and under.</li><li>• Make sure all children use seat belts or child seats.</li></ul>	
To be removed by owner only.	

## Canadian Models

To remind you of the front airbag hazards, your vehicle has warning labels on the driver's and front passenger's visors. Please read and follow the instructions on these labels.

<p><b>CAUTION</b> TO AVOID SERIOUS INJURY:</p> <ul style="list-style-type: none"><li>• FOR MAXIMUM SAFETY PROTECTION IN ALL TYPES OF CRASHES, YOU MUST ALWAYS WEAR YOUR SAFETY BELT.</li><li>• DO NOT INSTALL REARWARD-FACING CHILD SEATS IN ANY FRONT PASSENGER SEAT POSITION.</li><li>• DO NOT SIT OR LEAN UNNECESSARILY CLOSE TO THE AIR BAG.</li><li>• DO NOT PLACE ANY OBJECTS OVER THE AIR BAG OR BETWEEN THE AIR BAG AND YOURSELF.</li><li>• SEE THE OWNER'S MANUAL FOR FURTHER INFORMATION AND EXPLANATIONS.</li></ul>	<p><b>PRÉCAUTION:</b> POUR ÉVITER DES BLESSURES GRAVES:</p> <ul style="list-style-type: none"><li>• POUR PROFITER D'UNE PROTECTION MAXIMALE LORS D'UNE COLLISION BOUCLEZ TOUJOURS VOTRE CEINTURE DE SÉCURITÉ.</li><li>• N'INSTALLEZ JAMAIS UN SIÈGE POUR ENFANTS FAISANT FACE À L'ARRIÈRE SUR LE SIÈGE DU PASSAGER AVANT.</li><li>• NE VOUS APPUYEZ PAS ET NE VOUS ASSEYEZ PAS PRES DU COUSSIN GONFLABLE.</li><li>• NE DEPOSEZ AUCUN OBJET SUR LE COUSSIN GONFLABLE OU ENTRE LE COUSSIN GONFLABLE ET VOUS.</li><li>• LISEZ LE GUIDE UTILISATEUR POUR DE PLUS AMPLES RENSEIGNEMENTS.</li></ul>
--	---

## Protecting Children – General Guidelines

---

### If You Must Drive with Several Children

Your vehicle has two rows of back seats where children can be properly restrained. If you ever have to carry a group of children, and a child must ride in front:

- Place the largest child in the front seat, provided the child is large enough to wear the lap/shoulder belt properly (see page 38).
- Move the vehicle seat as far to the rear as possible (see page 10).
- Have the child sit upright and well back in the seat (see page 26).
- Make sure the seat belt is properly positioned and secured (see page 12).

### If a Child Requires Close Attention

Many parents say they prefer to put an infant or small child in the front passenger seat so they can watch the child, or because the child requires attention.

Placing a child in the front seat exposes the child to hazards in a frontal collision, and paying close attention to a child distracts the driver from the important tasks of driving, placing both of you at risk.

If a child requires physical attention or frequent visual contact, we strongly recommend that another adult ride with the child in the back seat. The back seat is far safer for a child than the front.

### Additional Safety Precautions

- Never hold an infant or child on your lap. If you are not wearing a seat belt in crash, you could be thrown forward and crush the child against the dashboard or a seat-back. If you are wearing a seat belt the child can be torn from your arms and be seriously hurt or killed.
- Never put a seat belt over yourself and a child. During a crash, the belt could press deep into the child and cause serious or fatal injuries.
- Never let two children use the same seat belt. If they do, they could be very seriously injured in a crash.
- Use childproof door locks to prevent children from opening the doors. This can prevent children from accidentally falling out.



## Protecting Children – General Guidelines, Protecting Infants

- Do not leave children alone in a vehicle. Leaving children without adult supervision is illegal in most states and Canadian provinces, and can be very hazardous. For example, infants and small children left in a vehicle on a hot day can die from heatstroke. A child left alone with the key in the ignition can accidentally set the vehicle in motion, possibly injuring themselves or others.
- Lock all doors and the tailgate when your vehicle is not in use. Children who play in vehicles can accidentally get trapped inside. Teach your children not to play in or around vehicles.
- Keep vehicle keys and remote transmitters out of the reach of children. Even very young children learn how to unlock vehicle doors, turn on the ignition, and open the trunk, which can lead to accidental injury or death.

### Protecting Infants *Child Seat Type*

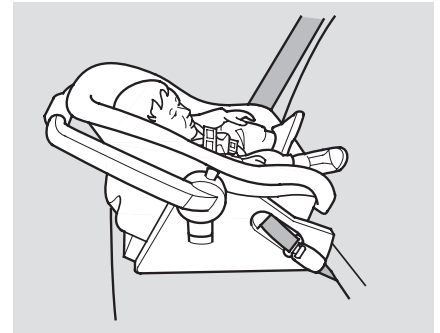

Only a rear-facing child seat provides proper support for a baby's head, neck, and back.

An infant must be properly restrained in a rear-facing, reclining child seat until the child reaches the seat maker's weight or height limit for the seat, and the child is at least one year old.

## Protecting Infants and Small Children

### **⚠ WARNING**

Placing a rear-facing child seat in the front seat can result in serious injury or death if the passenger's front airbag inflates.

Always place a rear-facing child seat in the back seat, not the front.

Two types of seats may be used: a seat designed exclusively for infants, or a convertible seat used in the rear-facing, reclining mode.

***Do not put a rear-facing child seat in a forward-facing position.*** If placed facing forward, an infant could be very seriously injured during a frontal collision.

### ***Child Seat Placement***

We strongly recommend installing a rear-facing child seat in a back seat.

***Never put a rear-facing child seat in the front seat.*** If the passenger's front airbag inflates, it can hit the back of the child seat with enough force to kill or seriously injure an infant.

When properly installed, a rear-facing child seat may prevent the driver or a front passenger from moving the seat as far back as recommended, or from locking the seat-back in the desired position, and interfering with the proper operation of the passenger's advanced front airbag (see page 22 ).

In any of these situations, we strongly recommend that you install the child seat in a different back seating position or get a smaller rear-facing child seat.

### **Protecting Small Children** ***Child Seat Type***



A child who is at least one year old, and who fits within the child seat maker's weight and height limits, should be restrained in a forward-facing, upright child seat.

Of the different seats available, we recommend those that have a five-point harness system as shown.

### ***Child Seat Placement***

We strongly recommend placing a forward-facing child seat in a back seat, not the front.

***Placing a forward-facing child seat in the front seat of a vehicle equipped with a passenger's airbag can be hazardous.*** If the vehicle seat is too far forward, or the child's head is thrown forward during a collision, an inflating airbag can strike the child with enough force to cause very serious or fatal injuries.

We also recommend that a small child stay in the child seat as long as possible, until the child reaches the weight or height limit for the seat.

If it is necessary to put a forward-facing child seat in the front, move the vehicle seat as far to the rear as possible, be sure the child seat is firmly secured to the vehicle, and the child is properly strapped in the seat.

### **⚠ WARNING**

Placing a forward-facing child seat in the front seat can result in serious injury or death if the front airbag inflates.

If you must place a forward-facing child seat in front, move the vehicle seat as far back as possible, and properly restrain the child.

### **Selecting a Child Seat**

When buying a child seat, you need to choose between a conventional child seat, or one designed for use with the Lower Anchors and Tethers for Children (LATCH) system.

Conventional child seats must be secured to a vehicle with a seat belt, whereas LATCH-compatible seats are secured by attaching the seat to hardware built into the two second-row seat.

*CONTINUED*

## Selecting a Child Seat, Installing a Child Seat

---

Since LATCH-compatible child seats are easier to install and reduce the possibility of improper installation, we recommend selecting this style.

We also recommend selecting a LATCH-compatible seat with a rigid, rather than a flexible, anchor (see page 33).

In seating positions and vehicles not equipped with LATCH, a LATCH-compatible child seat can be installed using a seat belt.

Whatever type of seat you choose, to provide proper protection, a child seat should meet three requirements:

**1. The child seat should meet U.S. or Canadian Motor Vehicle Safety Standard 213.** Look for FMVSS 213 or CMVSS 213 on the box.

**2. The child seat should be of the proper type and size to fit the child.** Rear-facing for infants, forward-facing for small children.

**3. The child seat should fit the vehicle seating position (or positions) where it will be used.**

Before purchasing a conventional child seat, or using a previously purchased one, we recommend that you test the seat in the specific vehicle seating position, or positions, where the seat will be used.

After selecting a proper child seat, and a good place to install the seat, there are three main steps in installing the seat:

**1. Properly secure the child seat to the vehicle.** All child seats must be secured to the vehicle with the lap part of a lap/shoulder belt or with the LATCH (Lower Anchors and Tethers for Children) system. A child whose seat is not properly secured to the vehicle can be endangered in a crash.

**2. Make sure the child seat is firmly secured.** After installing a child seat, push and pull the seat forward and from side to side to verify that it is secure.

A child seat secured with a seat belt should be installed as firmly as possible. However, it does not need to be “rock solid”. Some side-to-side movement can be expected and should not reduce the child seat’s effectiveness.

If the child seat is not secure, try installing it in a different seating position, or use a different style of child seat that can be firmly secured.

### **3. Secure the child in the child seat.**

Make sure the child is properly strapped in the child seat according to the child seat maker’s instructions. A child who is not properly secured in a child seat can be seriously injured in a crash.

The following pages provide guidelines on how to properly install a child seat. A forward-facing child seat is used in all examples, but the instructions are the same for a rear-facing child seat.

### **Installing a Child Seat Using LATCH**

Your vehicle is equipped with LATCH (Lower Anchors and Tethers for Children) at the second row seats. The lower anchors are located between the seat-back and seat bottom, and are to be used only with a child seat designed for use with LATCH.

The location of each lower anchor is marked with a small circle above the point.

To install a LATCH-compatible child seat:

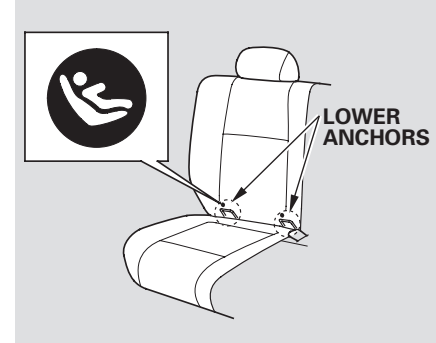

1. Move the seat belt buckle or tongue away from the lower anchors.
2. Make sure there are no objects near the anchors that could prevent a secure connection between the child seat and anchors.

## Installing a Child Seat

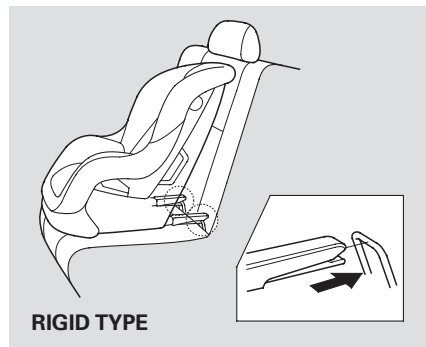

3. Place the child seat on the vehicle seat, and attach the seat to the lower anchors according to the child seat maker's instructions.

Some LATCH-compatible seats have a rigid-type connection as shown above.

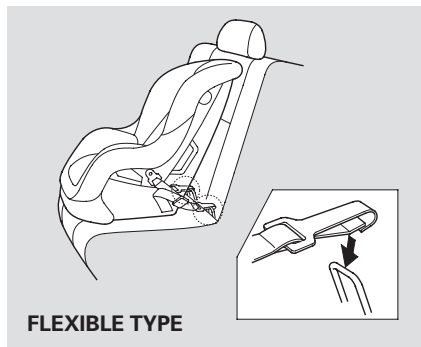

- Other LATCH-compatible seats have a flexible-type connection as shown above.
4. Whatever type you have, follow the child seat maker's instructions for adjusting or tightening the fit.

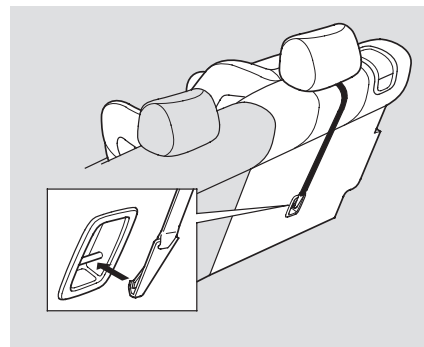

5. Attach the tether strap hook to the tether anchorage point on the underside of the seat cushion, then tighten the strap as instructed by the child seat maker. Make sure the strap is not twisted.
6. Push and pull the child seat forward and from side-to-side to verify that it is secure.

### Installing a Child Seat with a Lap/Shoulder Belt

When not using the LATCH system, all child seats must be secured to the vehicle with the lap part of a lap/shoulder belt.

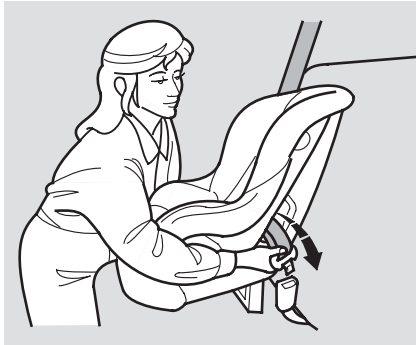

1. With the child seat in the desired seating position, route the belt through the child seat according to the seat maker's instructions, then insert the latch plate into the buckle.

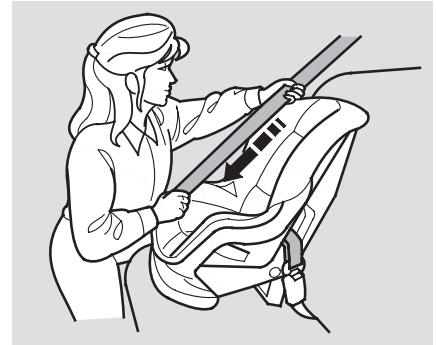

2. To activate the lockable retractor, slowly pull the shoulder part of the belt all the way out until it stops, then let the belt feed back into the retractor.
3. After the belt has retracted, tug on it. If the belt is locked, you will not be able to pull it out. If you can pull the belt out, it is not locked, and you will need to repeat these steps.

*CONTINUED*

## Installing a Child Seat



4. After confirming that the belt is locked, then grab the shoulder part of the belt near the buckle and pull up to remove any slack from the lap part of the belt. Remember, if the lap part of the belt is not tight, the child seat will not be secure.

To remove slack, it may help to put weight on the child seat, or push on the back of the seat while pulling up on the belt.

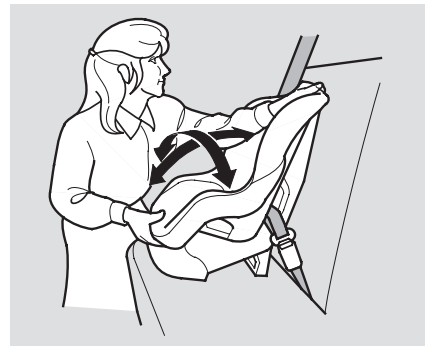

5. Push and pull the child seat forward and from side to side to verify that it is firmly secured. If the child seat is not secure, unlatch the belt, allow it to retract fully, then repeat these steps.

To deactivate the locking mechanism and remove a child seat, unlatch the buckle, unrout the seat belt, and let the belt fully retract.



### Installing a Child Seat with a Tether

Your vehicle has attachment points for a tether-style child seat to be installed on the second or third row as shown.

Since a tether can provide additional security, we recommend using a tether whenever one is required or available. (Tethers are required in Canada.)

#### *Second Seat Installation:*

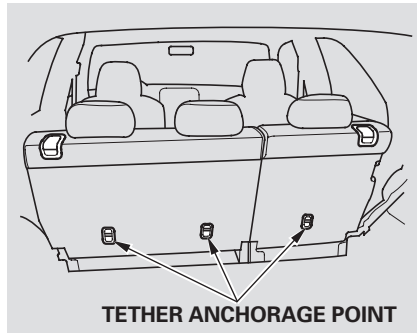

Each second row seat has a tether anchorage point behind the seat back.

#### *Third Seat Installation:*

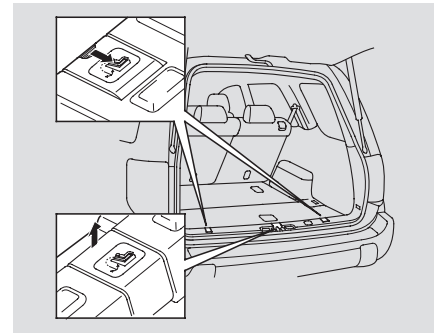

There are three anchorage points on the tailgate sill. Select the anchorage point you want to use, and slide the cover to open it (outboard anchor), or remove the cover (center anchor).

## Installing a Child Seat, Protecting Larger Children

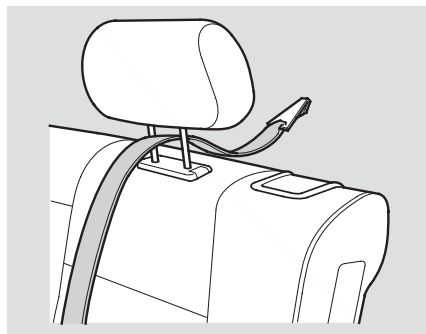

Lift the head restraint, then route the tether strap over the seat-back between the legs of the head restraint.

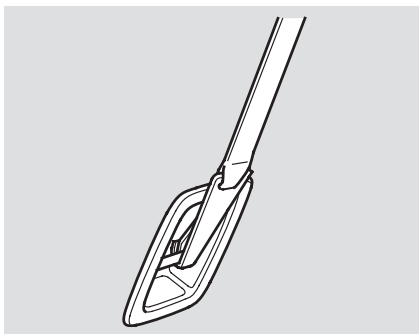

Attach the tether strap hook to the tether attachment point, and tighten the strap according to the child seat maker's instructions. Make sure the strap is not twisted.

### Protecting Larger Children

When a child reaches the recommended weight or height limit for a forward-facing child seat, the child should sit in a back seat on a booster and wear a lap/shoulder belt. The following pages give instructions on how to check proper seat belt fit, what kind of booster seat to use if one is needed, and important precautions for a child who must sit in front.

#### **⚠ WARNING**

Allowing a large child age 12 or under to sit in front can result in injury or death if the passenger's front airbag inflates.

If a large child must ride in front, move the vehicle seat as far back as possible, use a booster seat if needed, have the child sit up properly and wear the seat belt properly.

### Checking Seat Belt Fit



To determine if a lap/shoulder belt properly fits a child, have the child put on the seat belt, then ask yourself:

1. Does the child sit all the way back against the seat?
2. Do the child's knees bend comfortably over the edge of the seat?

3. Does the shoulder belt cross between the child's neck and arm?
4. Is the lap part of the belt as low as possible, touching the child's thighs?
5. Will the child be able to stay seated like this for the whole trip?

If you answer yes to all these questions, the child is ready to wear the lap/shoulder belt correctly. If you answer no to any question, the child needs to ride on a booster seat.

### Using a Booster Seat



A child who has outgrown a forward-facing child seat should ride in a back seat and use a booster seat until the lap/shoulder belt fits them properly without the booster.

Some states also require children to use a booster until they reach a given age or weight (e.g., 6 years or 60 lbs). Be sure to check current laws in the state or states where you intend to drive.

## Protecting Larger Children

---

Booster seats can be high-back or low-back. Whichever style you select, make sure the booster meets federal safety standards (see page 25 ) and that you follow the booster seat maker's instructions.

If a child who uses a booster must ride in front, move the vehicle seat as far to the rear as possible, and be sure the child is wearing the seat belt properly.

A child may continue using a booster seat until the tops of their ears are even with the top of the vehicle's or booster's seat-back. A child of this height should be tall enough to use the lap/shoulder belt without a booster.

### ***When Can a Larger Child Sit in Front***

The National Highway Traffic Safety Administration and Transport Canada recommend that all children ages 12 and under be properly restrained in the back seat.

If the passenger's front airbag is on, and it inflates in a moderate to severe frontal collision, the airbag can cause serious injuries to a child who is unrestrained, improperly restrained, sitting too close to the airbag, or out of position.

The side airbag also poses risks. If any part of a larger child's body is in the path of a deploying side airbag, the child could receive possibly serious injuries.

Of course, children vary widely. And while age may be one indicator of when a child can safely ride in the front. There are other important factors you should consider.

### ***Maturity***

To safely ride in front, a child must be able to follow the rules, including sitting properly, and wearing the seat belt properly throughout a ride.

### ***Physical Size***

Physically, a child must be large enough for the lap/shoulder belt to properly fit (see page 39 ). If the seat belt does not fit properly, with or without the child sitting on a booster, the child should not sit in the front.

If you decide that a child can safely ride up front, be sure to:

- Carefully read the owner's manual and make sure you understand all seat belt instructions and all safety information.
- Move the vehicle seat to the rear-most position.
- Have the child sit up straight, back against the seat, and feet on or near the floor.
- Check that the child's seat belt is properly positioned and secured.
- Supervise the child. Even mature children sometimes need to be reminded to fasten the seat belts or sit properly.

### **Additional Safety Precautions**

***Do not let a child wear a seat belt across the neck.*** This could result in serious neck injuries during a crash.

***Do not let a child put the shoulder part of a seat belt behind the back or under the arm.*** This could cause very serious injuries during a crash. It also increases the chance that the child will slide under the belt in a crash and be injured.

***Two children should never use the same seat belt.*** If they do, they could be very seriously injured in a crash.

***Do not put any accessories on a seat belt.*** Devices intended to improve a child's comfort or reposition the shoulder part of a seat belt can make the belt less effective, and increase the chance of serious injury in a crash.

## Carbon Monoxide Hazard

---

Your vehicle's exhaust contains carbon monoxide gas. You should have no problem with carbon monoxide entering the vehicle in normal driving if you maintain your vehicle properly. Have the exhaust system inspected for leaks whenever:

- The vehicle is raised for an oil change.
- You notice a change in the sound of the exhaust.
- The vehicle was in an accident that may have damaged the underside.

### **WARNING**

Carbon monoxide gas is toxic. Breathing it can cause unconsciousness and even kill you.

Avoid any enclosed areas or activities that expose you to carbon monoxide.

High levels of carbon monoxide can collect rapidly in enclosed areas, such as a garage. Do not run the engine with the garage door closed. Even with the door open, run the engine only long enough to move the vehicle out of the garage.

With the tailgate open, air flow can pull exhaust gas into your vehicle's interior and create a hazardous condition. If you must drive with the tailgate open, open all the windows and set the heating and cooling system/climate control system as shown below.

If you must sit in your parked vehicle, even in an unconfined area, with the engine running, adjust the heating and cooling system/climate control system as follows:

1. Select the Fresh Air mode.
2. Select the  mode.
3. Turn the fan on high speed.
4. Set the temperature control to a comfortable setting.

These labels are in the locations shown. They warn you of potential hazards that could cause serious injury. Read these labels carefully. If a label comes off or becomes hard to read, contact your Honda dealer for a replacement.

## HOOD

**⚠ WARNING**

Accidental deployment can seriously hurt or kill you.  
Follow Service Manual instructions carefully.

**⚠ ATTENTION**

Un déploiement accidentel risque de causer de graves blessures, voire la mort.  
Suivre attentivement les instructions du manuel de réparation.

## RADIATOR CAP

**DANGER**  
**WARNING**  
**危険**

▶ NEVER OPEN WHEN HOT.  
Hot coolant will scald you.  
▶ N'OUVREZ PAS QUAND CHAUD.  
NIGHT BEI HEISSEN MOTOR OFFEN.  
▶ 熱い時あけないうで下さい。  
▶ 高温時、請勿打开。

**1.1**

## DASHBOARD

*U.S. models only*

**⚠ WARNING**

**Children Can Be KILLED or INJURED by Passenger Air Bag**

- The back seat is the safest place for children 12 and under.
- Make sure all children use seat belts or child seats.

To be removed by owner only.

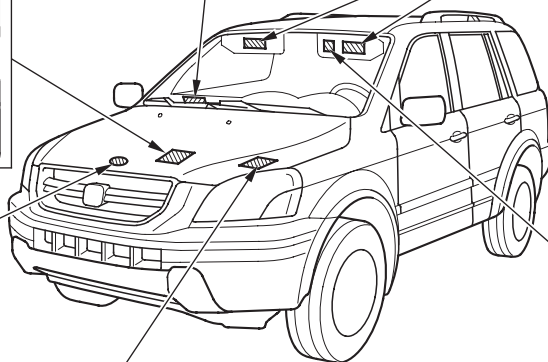

## BATTERY LABEL

## SUN VISOR

*U.S. models*

**⚠ WARNING**

**DEATH or SERIOUS INJURY can occur**

- Children 12 and under can be killed by the air bag
- The BACK SEAT is the SAFEST place for children
- NEVER put a rear-facing child seat in the front
- Sit as far back as possible from the air bag
- ALWAYS use SEAT BELTS and CHILD RESTRAINTS

## Canadian models

<p><b>CAUTION</b> TO AVOID SERIOUS INJURY: • FOR MAXIMUM SAFETY PROTECTION IN ALL TYPES OF CRASHES, YOU MUST ALWAYS WEAR YOUR SAFETY BELT. • DO NOT INSTALL REARWARD-FACING CHILD SEATS IN ANY FRONT PASSENGER SEAT POSITION. • DO NOT SIT OR LEAN UNNECESSARILY CLOSE TO THE AIR BAG. • DO NOT PLACE ANY OBJECTS OVER THE AIR BAG OR BETWEEN THE AIR BAG AND YOURSELF. • SEE THE OWNER'S MANUAL FOR FURTHER INFORMATION AND EXPLANATIONS.</p>	<p><b>PRÉCAUTION:</b> POUR ÉVITER DES BLESSURES GRAVES: MAXIMALE LORS D'UNE COLLISION BOUCLEZ TOUJOURS VOTRE CEINTURE DE SÉCURITÉ. • N'INSTALLEZ JAMAIS UN SIÈGE POUR ENFANTS FAISANT FACE À L'ARRIÈRE SUR LE SIÈGE DU PASSAGER AVANT. • NE VOUS APPUYEZ PAS ET NE VOUS ASSEYEZ PAS PRES DU COUSSIN GONFLABLE. • NE D'POSEZ AUCUN OBJET SUR LE COUSSIN GONFLABLE OU ENTRE LE COUSSIN GONFLABLE ET VOUS. • LISEZ LE GUIDE UTILISATEUR POUR DE PLUS AMPLES RENSEIGNEMENTS.</p>
--	--

**⚠ WARNING: HIGHER ROLLOVER RISK**

	<p>Avoid Abrupt Maneuvers and Excessive Speed.</p> <p>Always Buckle Up.</p> <p>See Owner's Manual For Further Information.</p>	
--	--	--





This section gives information about the controls and displays that contribute to the daily operation of your Honda. All the essential controls are within easy reach.

Control Locations .....	46	Parking Brake .....	75
Instrument Panel .....	47	Interior Convenience Items.....	76
Gauges .....	54	Beverage Holders.....	77
Odometer/Trip Meter .....	54	Console Compartment .....	77
Fuel Gauge .....	54	Sunglasses Holder .....	78
Temperature Gauge .....	55	Glove Box .....	78
Outside Temperature Gauge .....	55	Sun Visor.....	78
Controls Near the Steering		Lights .....	79
Wheel .....	56		
Windshield Wipers and Washers ..	57		
Turn Signal and Headlights.....	58		
Instrument Panel Brightness .....	59		
Hazard Warning Button.....	59		
Rear Window Defogger .....	60		
Steering Wheel Adjustment .....	61		
Keys and Locks.....	62		
Immobilizer System.....	62		
Ignition Switch .....	64		
Door Locks .....	65		
Power Door Locks.....	65		
Childproof Door Locks .....	65		
Remote Transmitter .....	66		
Seats Heaters .....	67		
Seats .....	68		
Power Windows .....	73		
Mirrors.....	74		

## Control Locations

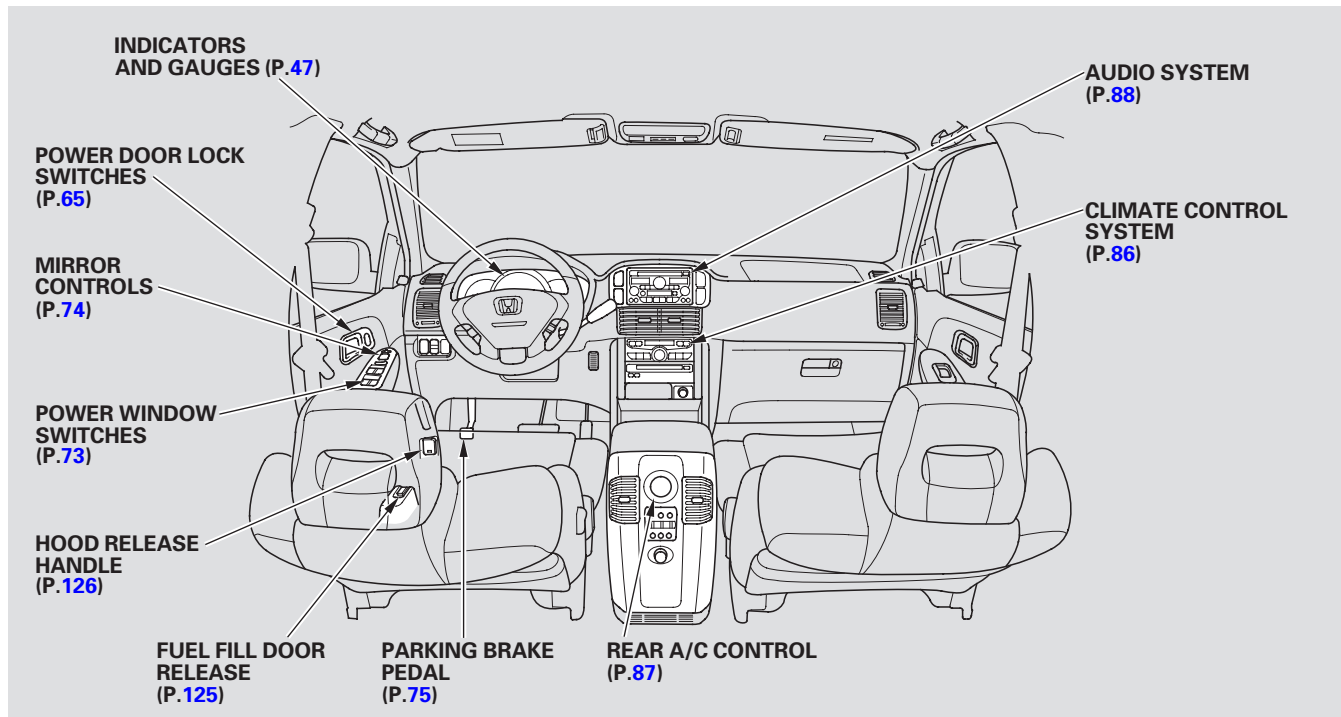

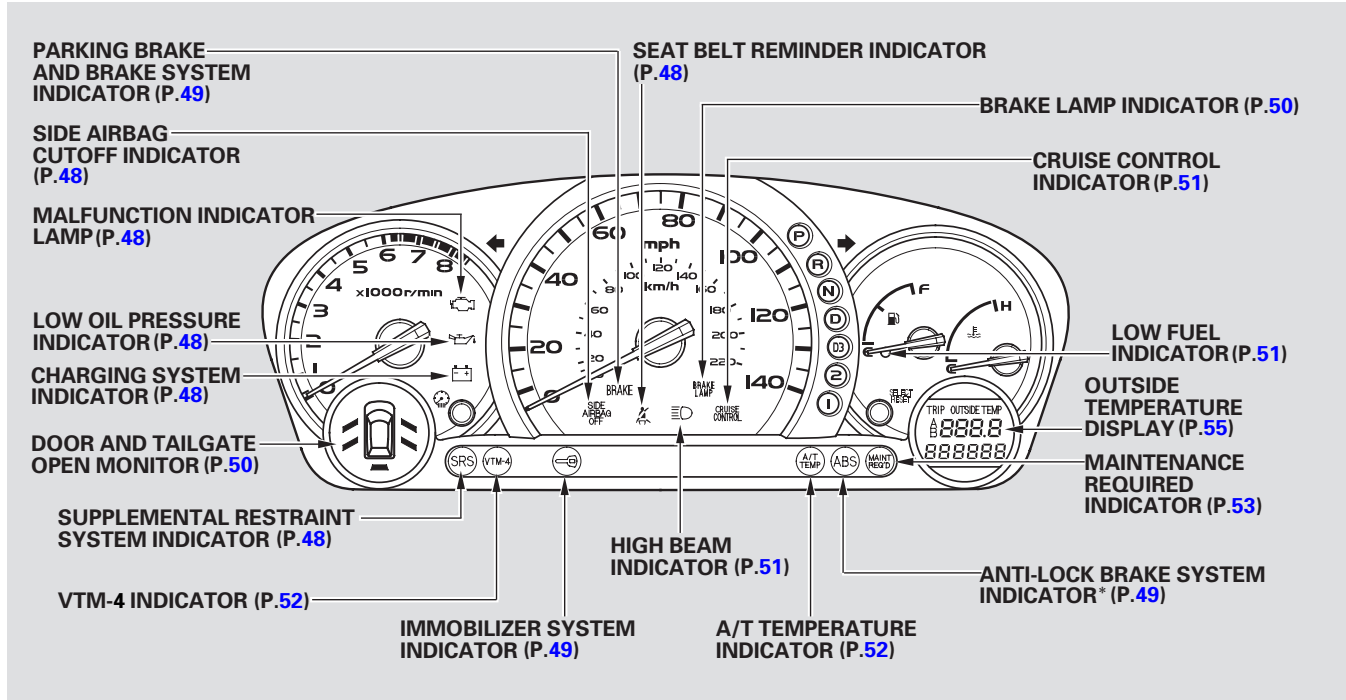

\* The U.S. instrument panel is shown. Differences for the Canadian models are noted in the text.

CONTINUED

## Instrument Panel

---

The instrument panel has many indicators to give you important information about your vehicle.



### Seat Belt Reminder Indicator

This indicator comes on when you turn the ignition switch to ON (II). It reminds you and your passengers to fasten your seat belts. A beeper also sounds if you have not fastened your seat belt.

If you turn the ignition switch to ON (II) before fastening your seat belt, the beeper sounds and the indicator flashes. If you do not fasten your seat belt before the beeper stops, the indicator stops flashing but remains on.

If you continue driving without fastening your seat belt, the beeper sounds and the indicator flashes again at regular intervals.



### Malfunction Indicator Lamp

See page [207](#).



### Low Oil Pressure Indicator

The engine can be severely damaged if this indicator flashes or stays on when the engine is running. For more information, see page [206](#).



### Charging System Indicator

If this indicator comes on when the engine is running, the battery is not being charged. For more information, see page [206](#).



### Supplemental Restraint System Indicator

This indicator comes on when you turn the ignition switch to ON (II). If it comes on at any other time, it indicates a potential problem with your front airbags. This indicator will also alert you to a potential problem with your side airbags, passenger's side airbag automatic cutoff system or automatic seat belt tensioners. For complete information, see page [23](#).



### Side Airbag Off Indicator

This indicator comes on when you turn the ignition switch to ON (II). If it comes on at any other time, it indicates that the passenger's side airbag has automatically shut off. For complete information, see page [23](#).

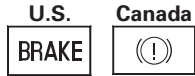

## Parking Brake and Brake System Indicator

This indicator has two functions:

1. It comes on when you turn the ignition switch to ON (II). It is a reminder to check the parking brake. Driving with the parking brake not fully released can damage the brakes and tires. A chime also sounds if you try to drive with the parking brake on.
2. If it remains lit after you have fully released the parking brake while the engine is running, or if it comes on while driving, there could be a problem with the brake system. For complete information, see page [208](#).

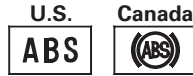

## Anti-lock Brake System (ABS) Indicator

This indicator normally comes on for a few seconds when you turn the ignition switch to ON (II), and when the ignition switch is turned to START (III). If it comes on at any other time, there is a problem in the ABS. If this happens, have your vehicle checked at a dealer. With this indicator on, your vehicle still has normal braking ability but not anti-lock. For complete information, see page [145](#).



## Immobilizer System Indicator

This indicator comes on for a few seconds when you turn the ignition switch to ON (II). It will go off if you have inserted a properly-coded ignition key. If it is not a properly-coded key, the indicator will blink and the engine will not start (see page [62](#)).

This indicator also blinks several times when you turn the ignition switch from ON (II) to ACCESSORY (I) or LOCK (0).

## Instrument Panel

---



### Turn Signal and Hazard Warning Indicators

The left or right turn signal indicator blinks when you signal a lane change or turn. If the indicators do not blink or blink rapidly, it usually means one of the turn signal bulbs is burned out (see page 181). Replace the bulb as soon as possible, since other drivers cannot see that you are signaling.

When you push the Hazard Warning button, both turn signal indicators blink. All turn signals on the outside of the vehicle should flash.



### Brake Lamp Indicator

If a brake light does not work, the **BRAKE LAMP** indicator comes on when you push the brake pedal with the ignition switch in the ON (II) position.

A burned out brake light is a hazard when drivers behind you cannot tell you are braking. Have your brake lights repaired right away.

### Door and Tailgate Open Monitor

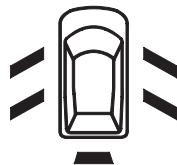

The appropriate indicator comes on in this display if the tailgate or any door is not closed tightly.

All the indicators in the monitor display come on for a few seconds when you turn the ignition switch to ON (II).

**DRL**

## “Daytime Running Lights” Indicator

*Canadian models only*

This indicator comes on when you turn the ignition switch to ON (II) with the headlight switch off and the parking brake set. It should go off if you turn on the headlights or release the parking brake. If it comes on at any other time, it means there is a problem with the DRL. There may also be a problem with the high beam headlights.

**CRUISE CONTROL**

## Cruise Control Indicator

This indicator comes on when you set the cruise control. See page [116](#) for information on operating the cruise control.



## High Beam Indicator

This indicator comes on with the high beam headlights. See page [58](#) for information on the headlight controls.

On Canadian models, this indicator comes on with reduced brightness when the Daytime Running Lights (DRL) are on (see page [59](#)).

## Low Fuel Indicator

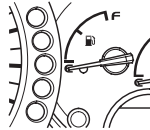

This indicator comes on as a reminder that you must refuel soon.



## Washer Level Indicator

*Canadian models only*

This indicator comes on when the washer fluid level is low. Add washer fluid when you see this indicator come on (see page [175](#)).

## Instrument Panel

---

A/T  
TEMP

### A/T Temperature Indicator

This indicator monitors the temperature of the automatic transmission fluid. It comes on for a few seconds when you turn the ignition switch to ON (II). If it comes on while driving, it indicates the transmission fluid temperature is too high. Pull to the side of the road when it is safe, shift to Park, and let the engine idle until the light goes out.

#### NOTICE

*Continuing to drive with the A/T Temperature indicator on may cause serious damage to the transmission.*

VTM-4

### VTM-4 Indicator

This indicator normally comes on for a few seconds when you turn the ignition switch to ON (II). If this indicator comes on at any other time, there is a problem in the 4WD system. Have your vehicle checked by a dealer.

If the indicator blinks while driving, pull to the side of the road when it is safe, shift to Park, and let the engine idle until the indicator goes out.

#### NOTICE

*Continuing to drive with the VTM-4 indicator blinking may cause serious damage to the 4WD system.*



## Maintenance Required Indicator

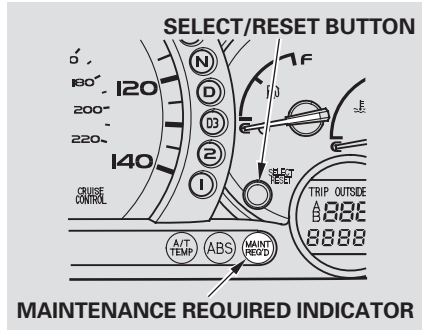

This indicator reminds you that it is time to take your vehicle in for scheduled maintenance. Refer to the Maintenance Schedules for Normal and Severe Driving Conditions on pages [164](#) and [165](#).

For the first 6,000 miles (9,600 km) after the Maintenance Required Indicator is reset, it will come on for two seconds when you turn the ignition switch to ON (II).

Between 6,000 miles (9,600 km) and 7,500 miles (12,000 km) this indicator will light for two seconds when you first turn the ignition switch to ON (II), and then flash for ten seconds.

If you exceed 7,500 miles (12,000 km) without having the scheduled maintenance performed, this indicator will remain on as a constant reminder.

Your dealer will reset this indicator after completing the scheduled maintenance. If this maintenance is done by someone other than your Honda dealer, reset the indicator as follows.

1. Turn off the engine.
2. Press and hold the Select/Reset button on the instrument panel, then turn the ignition switch ON (II).
3. Hold the button for approximately ten seconds until the indicator resets.

# Gauges

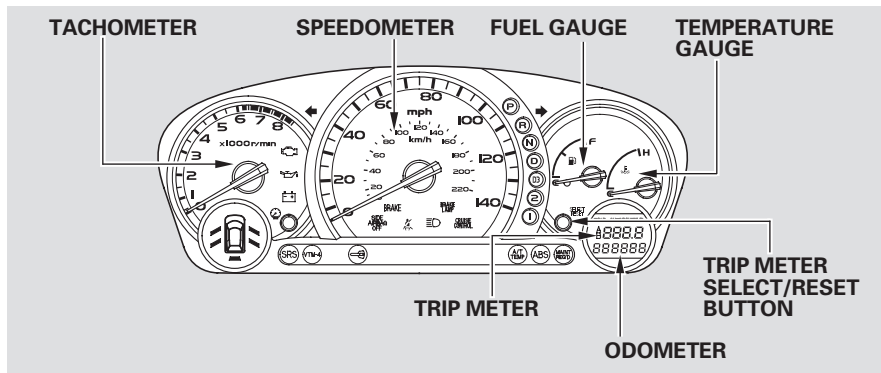

## Trip Meter

This meter shows the number of miles (U.S.) or kilometers (Canada) driven since you last reset it.

There are two trip meters: Trip A and Trip B. Switch between these displays and the outside temperature display (EX model only) by pressing the Select/Reset button repeatedly.

Each trip meter works independently, so you can keep track of two different distances.

To reset a trip meter, display it, and then press and hold the Select/Reset button until the number resets to "0.0". Both trip meters will reset if the vehicle's battery goes dead or is disconnected.

## Odometer

The odometer shows the total distance your vehicle has been driven. It measures miles in U.S. models and kilometers in Canadian models. It is illegal under U.S. federal law and Canadian provincial regulations to disconnect, reset, or alter the odometer with the intent to change the number of miles or kilometers indicated.

## Fuel Gauge

This shows how much fuel you have. It may show slightly more or less than the actual amount. The needle returns to the bottom after you turn off the ignition.

### NOTICE

*Avoid driving with an extremely low fuel level. Running out of fuel could cause the engine to misfire, damaging the catalytic converter.*

### Temperature Gauge

This shows the temperature of the engine's coolant. During normal operation, the pointer should rise from the bottom white mark to about the middle white mark. In severe driving conditions, such as very hot weather or a long period of uphill driving, the pointer may rise to the upper white mark. If it reaches the red (Hot) mark, pull safely to the side of the road. Turn to page [204](#) for instructions and precautions on checking the engine's cooling system.

### Outside Temperature Indicator

*On EX model*

This indicator displays the outside temperature in Fahrenheit (U.S. models) or Centigrade (Canadian models). To see the outside temperature, press and release the Select/Reset button until the temperature is displayed.

The temperature sensor is in the front bumper. Therefore, the temperature reading can be affected by heat reflection from the road surface, engine heat, and the exhaust from surrounding traffic. This can cause an incorrect temperature reading when your speed is under 19 mph (30 km/h).

The sensor delays the display update until it reaches the correct outside temperature, this may take several minutes.

In certain weather conditions, temperature readings near freezing (32°F, 0°C) could mean that ice is forming on the road surface.

## Controls Near the Steering Wheel

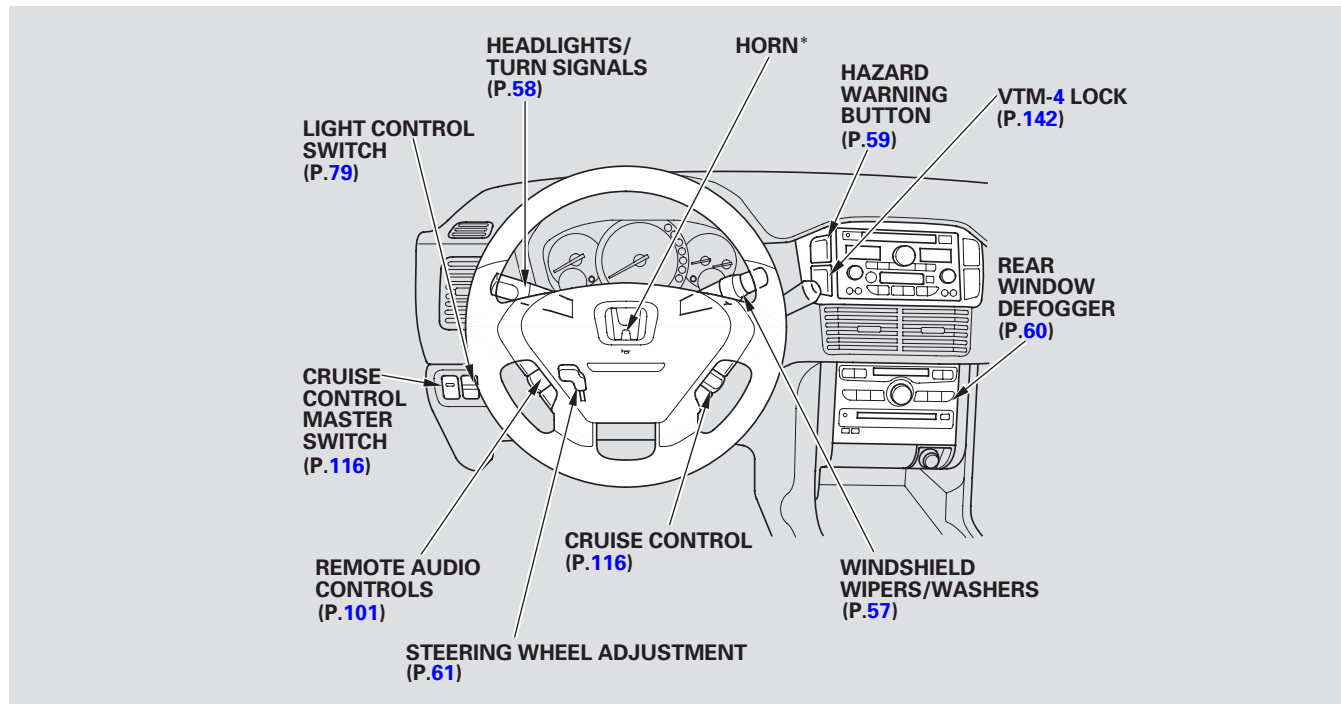

\* To use the horn, press the pad around the “H” logo.

## Windshield Wipers and Washers

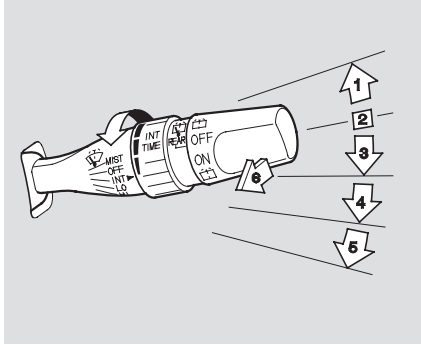

1. MIST
2. OFF
3. INT — Intermittent
4. LO — Low
5. HI — High
6. Windshield Washers

Push the right lever up or down to select a position.

**MIST** — The wipers run at high speed until you release the lever.  
**OFF** — The wipers are not activated.

**INT** — The length of the wiper interval is varied automatically according to the vehicle's speed.

Vary the delay by turning the INT TIME ring. If you turn it to the shortest delay, the wipers will change to low speed operation when the vehicle speed exceeds 12 mph (20 km/h).

**LO** — The wipers run at low speed.  
**HI** — The wipers run at high speed.

**Windshield Washer** — Pull the wiper control lever toward you and hold it. The washers spray until you release the lever. The wipers run at low speed, then complete one more sweep after you release the lever.

### Rear Window Wiper and Washer

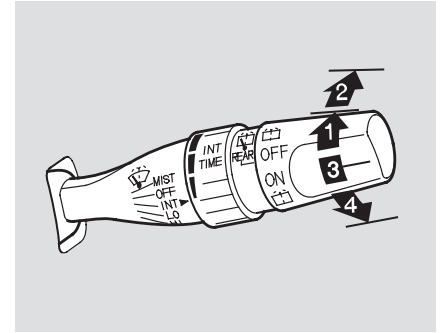

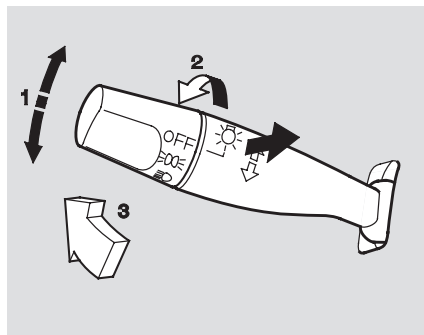

1. Rotate the switch clockwise to turn the rear window wiper ON.
2. Hold past ON to turn the window wiper on and the window washer to spray.
3. OFF
4. Rotate the switch counterclockwise to turn the window wiper on and the window washer to spray.

## Turn Signal and Headlights



1. Turn Signal
2. Headlights On
3. High Beams



**Turn Signal** — Push down on the left lever to signal a left turn and up to signal a right turn. To signal a lane change, push lightly on the lever and hold it. The lever will return to center when you release it or complete a turn.

**Headlights On** — Rotating switch on the left lever to the “ ” position turns on the parking lights, taillights, instrument panel lights, side-marker lights, and rear license plate lights. Turning the switch to the “ ” position turns on the headlights. If you leave the lights on with the ignition switch in the ACCESSORY (I) or LOCK (0) position, you will hear a reminder chime when you open the driver’s door.

**High Beams** — To turn on, push the lever forward until you hear a click. The blue high beam indicator will light (see page 51). Pull it back to return to low beams. To flash the high beams, pull the lever back lightly, then release it. The high beams will stay on as long as you hold the lever back.

### Automatic Lighting Off Feature *On EX model*

This feature turns off the headlights, fog lights, parking lights, taillights, side marker lights, license plate lights, and instrument panel lights within 15 seconds of removing the key from the ignition switch and closing the driver’s door.

This feature activates if you leave the headlight switch in the “ ” or “ ” position, remove the key, then open and close the driver’s door. If you remove the key from the ignition switch with the headlight switch on, but do not open the door and get out, the lights will turn off after 10 minutes.

## Headlights, Instrument Panel Brightness, Hazard Warning Button

The lights will turn on again when you unlock or open the driver's door. If you unlock the door, but do not open it within 15 seconds, the lights will go off. With the driver's door open, you will hear a lights-on reminder chime.

### Daytime Running Lights (Canadian Models)

With the headlight switch off, the high beam headlights come on with reduced brightness when you turn the ignition switch ON (II) and release the parking brake. They remain on until you turn the ignition off, even if you set the parking brake.

The headlights revert to normal operation when you turn the switch to the "  " position.

### Instrument Panel Brightness

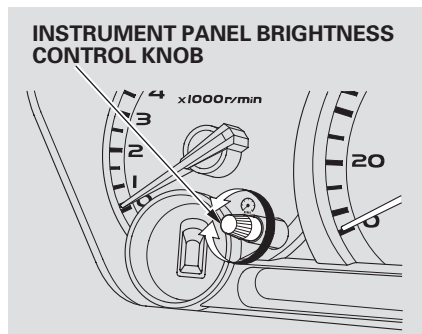

The knob on the instrument panel controls the brightness of the instrument panel lights. Turn the knob to adjust the brightness.

### Hazard Warning Button



Push the red button to turn on the hazard warning lights (four-way flashers). This causes all four outside turn signals and both indicators in the instrument panel to flash. Use the hazard warning lights if you need to park in a dangerous area near heavy traffic, or if your vehicle is disabled.

## Rear Window Defogger

---

EX model

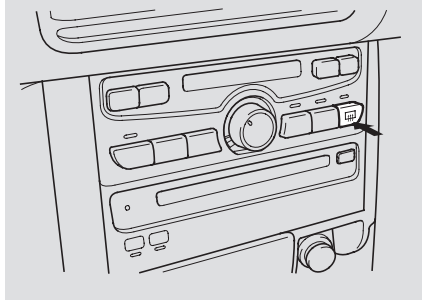

The rear window defogger will clear fog, frost, and thin ice from the window. Push the defogger button to turn it on and off. The indicator above the button lights to show the defogger is on. If you do not turn it off, the defogger will shut itself off after about 15 minutes. It also shuts off when you turn off the ignition. You have to turn it on again when you restart the vehicle.

LX model

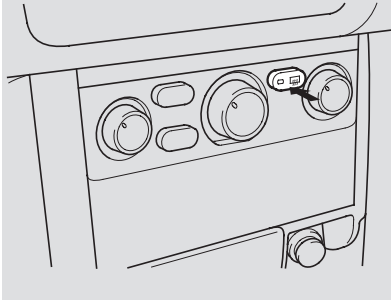

Make sure the rear window is clear and you have good visibility before starting to drive.

The defogger wires on the inside of the rear window can be accidentally damaged. When cleaning the glass, always wipe side-to-side.



See page 14 for important safety information about how to properly position the steering wheel.

Make any steering wheel adjustment before you start driving.

### **⚠ WARNING**

Adjusting the steering wheel position while driving may cause you to lose control of the vehicle and be seriously injured in a crash.

Adjust the steering wheel only when the vehicle is stopped.

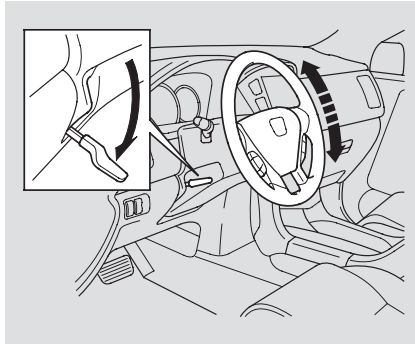

1. Push the lever under the steering column all the way down.
2. Move the steering wheel so it points to your chest, not toward your face. Make sure you can see the instrument panel gauges and indicators.
3. Push the lever up to lock the steering wheel in that position.
4. Make sure you have securely locked the steering wheel in place by trying to move it up and down.

## Keys and Locks, Immobilizer System

---

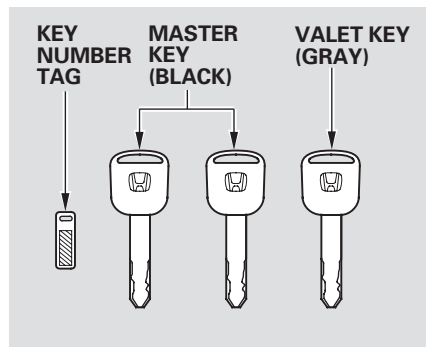

The master key fits all the locks on your vehicle. The valet key works only in the ignition and the door locks. You can keep the glove box locked when you leave your vehicle and the valet key at a parking facility.

You should have received a key number tag with your set of keys. You will need this key number if you ever have to get a key replaced. Use only Honda-approved key blanks.

### Immobilizer System

These keys contain electronic circuits that are activated by the Immobilizer System. They will not work to start the engine if the circuits are damaged.

- Protect the keys from direct sunlight, high temperature, and high humidity.
- Do not drop the keys or set heavy objects on them.
- Keep the keys away from liquids. If they get wet, dry them immediately with a soft cloth.

The keys do not contain batteries. Do not try to take them apart.

The Immobilizer System protects your vehicle from theft. If an improperly-coded key (or other device) is used, the engine's fuel system is disabled.

When you turn the ignition switch to ON (II), the Immobilizer System indicator should come on for a few seconds, then go out. If the indicator starts to blink, it means the system does not recognize the coding of the key. Turn the ignition switch to LOCK (0), remove the key, reinsert it, and turn the switch to ON (II) again.

The system may not recognize your key's coding if another immobilizer key or other metal object (i.e. key fob) is near the ignition switch when you insert the key.

If the system repeatedly does not recognize the coding of your key, contact your Honda dealer.

Do not attempt to alter this system or add other devices to it. Electrical problems could result that may make your vehicle undriveable.

If you have lost your key and cannot start your engine, contact a Honda dealer.

*As required by the FCC:*

*This device complies with Part 15 of the FCC rules. Operation is subject to the following two conditions: (1) This device may not cause harmful interference, and (2) this device must accept any interference received, including interference that may cause undesired operation.*

*Changes or modifications not expressly approved by the party responsible for compliance could void the user's authority to operate the equipment.*

*This device complies with Industry Canada Standard RSS-210. Operation is subject to the following two conditions: (1) this device may not cause interference, and (2) this device must accept any interference that may cause undesired operation of the device.*

## Ignition Switch

---

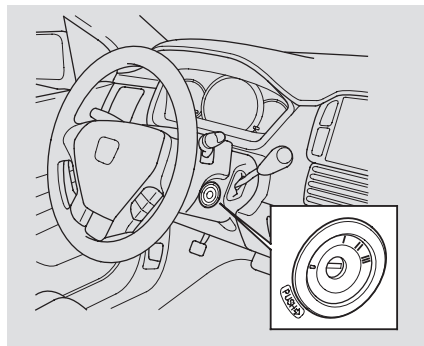

The ignition switch has four positions: LOCK (0), ACCESSORY (I), ON (II), and START (III).

**LOCK (0)** – You can insert or remove the key only in this position. To turn the key, the shift lever must be in Park, and you must push the key in slightly.

If the front wheels are turned, the anti-theft lock may make it difficult to turn the key. Firmly turn the steering wheel to the left or right as you turn the key.

**ACCESSORY (I)** – You can operate the audio system and the accessory power sockets in this position.

**ON (II)** – This is the normal key position when driving. Several of the lights on the instrument panel come on as a test when you turn the ignition switch from ACCESSORY (I) to ON (II).

**START (III)** – Use this position only to start the engine. The switch returns to ON (II) when you let go of the key.

You will hear a reminder beeper if you leave the key in the ignition switch in the LOCK (0) or ACCESSORY (I) position and open the driver's door. Remove the key to turn off the beeper.

The shift lever must be in Park before you can remove the key from the ignition switch.

### Power Door Locks

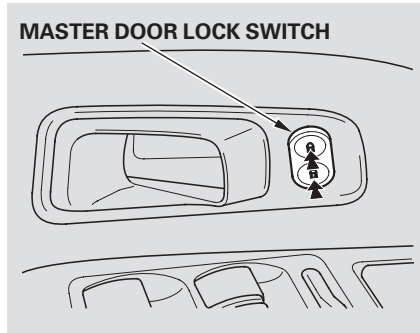

Each door has a lock tab on the top. When you push down the tab on the driver's door or use the key, all the doors and the tailgate lock. To lock the front passenger's door, push the lock tab down and close the door.

To unlock only the driver's door from the outside, turn the key and release it. If you turn the key and hold it, all doors and the tailgate unlock. All four doors and the

tailgate unlock when you use the key in the passenger's door.

### Lockout Prevention

With the driver's door open and the key in the ignition, both master door lock switches are disabled. They are not disabled if the driver's door is closed. Pushing the switch down on the open passenger's door will lock all doors.

### Tailgate

To open the tailgate, pull the handle, then lift up. To close the tailgate, use the inner handle to pull it down, then press down on the back edge.

Keep the tailgate closed at all times while driving to avoid damaging it and to prevent exhaust gas from getting into the interior. See **Carbon Monoxide Hazard**, page 42 .

### Childproof Door Locks

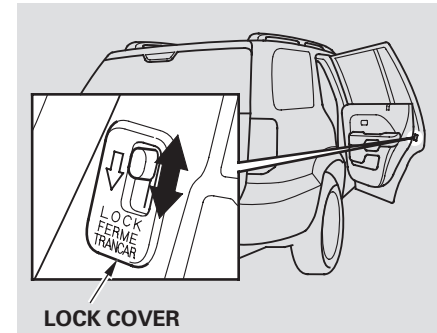

The childproof door locks are designed to prevent children seated in the rear from accidentally opening the rear doors. Each rear door has a lock lever near the edge. With the lever in the LOCK position, the door cannot be opened from the inside regardless of the position of the lock tab. To open the door, pull the lock tab up and use the outside door handle.

## Remote Transmitter

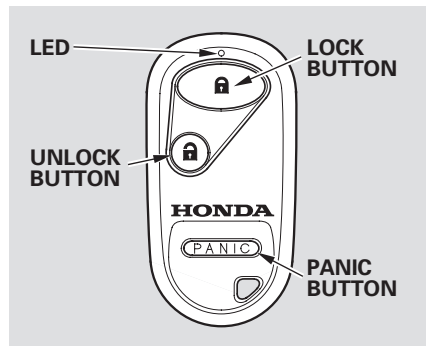

**LOCK** — Press this button once to lock all doors and the tailgate. Some exterior and interior lights will flash. When you push LOCK twice within 5 seconds, you will hear a beep to verify that the security system has set. You cannot lock it if any door is not fully closed or key is in the ignition switch.

**UNLOCK** — Press this button once to unlock the driver's door. Push it twice to unlock the other doors and

the tailgate. If you do not open any doors or the tailgate within 30 seconds, they will automatically relock.

**PANIC** — Press this button for about one second to attract attention; the horn will sound and the exterior lights will flash for about 30 seconds. To cancel panic mode, press any other button on the remote transmitter or turn the ignition switch to ON (II).

### *Remote Transmitter Care*

- Avoid dropping or throwing the transmitter.
- Protect the transmitter from extreme temperature.
- Do not immerse the transmitter in any liquid.
- If you lose a transmitter, the replacement needs to be reprogrammed by a Honda dealer.

### *Replacing the Transmitter Battery*

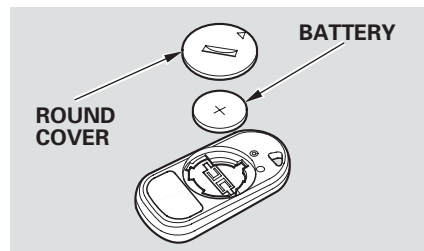

If it takes several pushes on the button to lock or unlock the doors and the tailgate, replace the battery as soon as possible.

Battery type: CR2025

To replace the battery, remove the round cover on the back of the transmitter by turning it counterclockwise with a coin. Insert a new battery with the + side facing up. Align the ∇ mark on the cover with the ⊙ mark on the transmitter. Set the cover in place and turn it clockwise.

*As required by the FCC:*

*This device complies with Part 15 of the FCC rules. Operation is subject to the following two conditions: (1) This device may not cause harmful interference, and (2) this device must accept any interference received, including interference that may cause undesired operation.*

*Changes or modifications not expressly approved by the party responsible for compliance could void the user's authority to operate the equipment.*

*This device complies with Industry Canada Standard RSS-210.*

*Operation is subject to the following two conditions: (1) this device may not cause interference, and (2) this device must accept any interference that may cause undesired operation of the device.*

### Seat Heaters (If equipped)

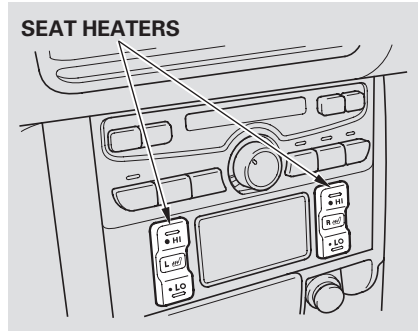

Both front seats are equipped with seat heaters. The passenger seat only has heaters in the seat bottom because of side airbag system. The ignition switch must be in the ON (II) position to use them. Push the top of the switch, HI, to rapidly heat up the seat. After the seat reaches a comfortable temperature, select LO by pushing the bottom of the switch. This will keep the seat warm.

In HI, the heater turns off when the seat gets warm, and turns back on after the seat's temperature drops.

In LO, the heater runs continuously. It does not cycle with temperature changes.

Follow these precautions whenever you use the seat heaters:

- Use the HI setting only to heat the seats quickly, because it draws large amounts of current from the battery.
- If the engine is left idling for an extended period, do not use the seat heaters even on the LO setting. It can weaken the battery, causing hard starting.

## Seats

### Power Seat Adjustment

*On EX model*

See pages 10 – 11 for important safety information and warnings about how to properly position seats and seat-backs.

The controls for the power adjustable driver's seat are on the outside edge of the seat bottom. You can adjust the power seat with the ignition switch in any position. Make all seat adjustments before you start driving.

Moving the long horizontal switch adjusts the seat bottom in several directions. The seat bottom adjusts in the direction you move the switch. The short vertical switch adjusts the seat back angle.

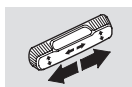
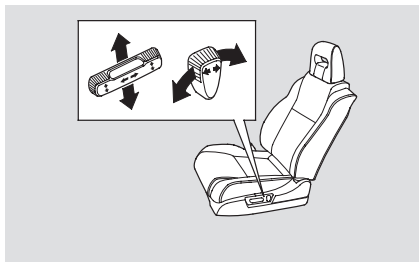

Moves the seat forward and backward.

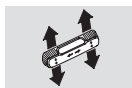

Moves the front of the seat up or down and the rear of the seat up or down.

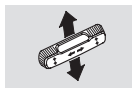

Raises or lowers the seat.



Adjusts the seat-back angle forward or backward.

### Driver's Lumbar Support

*On EX model*

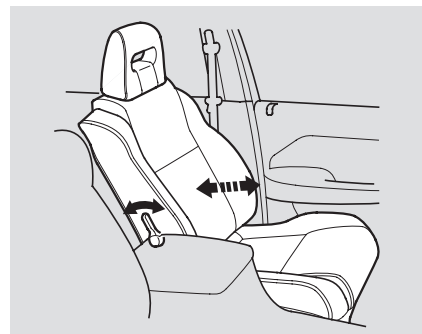

To change the lumbar support, move the lever on the right side of the seat-back forward or backward. Keep moving the lever forward or backward until you find a suitable position.



## Manual Seat Adjustments



*On LX model*

To adjust the seat forward and backward, pull up on the lever under the front seat cushion. Then try to move the seat to make sure it is locked into position.

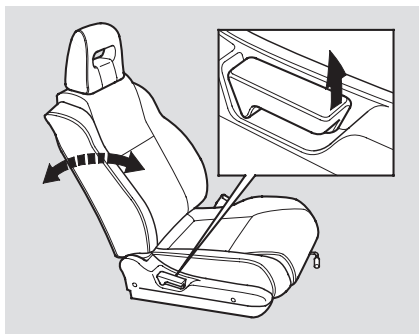

To change the seat-back angle of the front seat, pull up on the lever on the outside of the seat bottom.

## Driver's Seat Height Adjustment

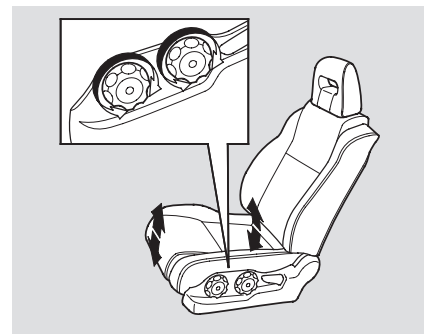

The height of your driver's seat is adjustable. Turn the front dial on the outside of the seat cushion to raise the front of the seat bottom, and turn the rear dial to raise the rear.

## Seats

### Adjusting the Second Row Seats

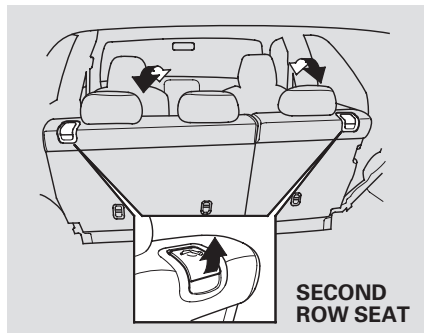

To change the angle of the seats in the second row seat-backs, pull up the handle on the seat-back. Moving the short vertical switch forward or backward adjusts the seat back in those directions.

To adjust the seats forward and backward, pull up on the lever under the seat cushion. After moving the seat, make sure it is locked into position.

### Folding the Second Row Seats

The left and right halves can be folded separately.

1. If you are folding the left half of the seat, use the ignition key to release the center seat belt from the detachable anchor (see page 72 ).
2. Lower the head restraint fully.
3. Pull up the handle on the outside of the seat-back.
4. Fold the seat-back forward.

Reverse this procedure to return the seat to its upright position. Make sure the seat is locked and secured before driving.

### Third Seat Access

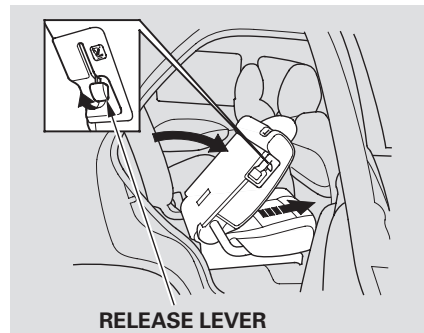

To get into the third row seats, pull up the lever on the outside of the passenger's side second row seat-back. The seat-back will tilt forward, and the seat will slide forward.

Push the whole seat backwards until fully latches. Make sure the seat is locked and secured before driving.

## Adjusting the Third Row Seat

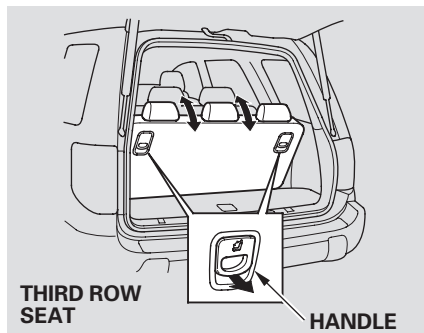

Pull the handle on the back of the seat, move the seat-back to the desired position and release the handle. Let the seat-back latch into the new position.

## Folding the Third Row Seat

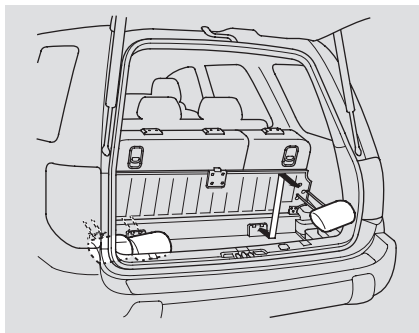

1. Remove the head restraints by pushing the release buttons and pulling the restraints out.
2. Store the head restraints under the cargo area floor. Insert the shafts into the holes in the sides of the storage compartment.

3. Use the ignition key to release the seat belt from the detachable anchor. See page [80](#) .
4. Unlock the seat-back by pulling the handle. Push the seat-back forward.

Make sure you clip the small latch plate of each outer shoulder belt to the seat belt webbing whenever the third seat is folded.

Reverse this procedure to return the seat to its upright position.

Reinstall the head restraints, reconnect the seat belts, and make sure the seats are secured before driving.

Make sure all items in the cargo area are secured. Loose items can fly forward and cause injury if you have to brake hard. See **Carrying Cargo** on page [131](#) .

## Seats

### Head Restraints

See page 12 for important safety information and a warning about how to properly position the head restraints.

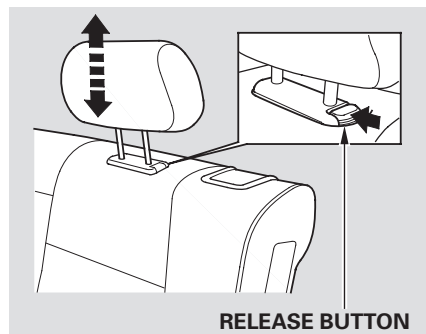

Your vehicle is equipped with head restraints in all seating positions to help protect you and your passengers whiplash and other injuries.

They are most effective when you adjust them so the back of the occupant's head rests against the center of the restraint.

The head restraints in the second and third row seats adjust for height. You need both hands to adjust the restraint. To raise it, pull upward. To lower it, push the release button sideways, and push the restraint down.

### **⚠ WARNING**

Using a seat belt with the detachable anchor unlatched increases the chance of serious injury or death in a crash.

Before using the seat belt, make sure the detachable anchor is correctly latched.

### Detachable Seat Belt Anchors

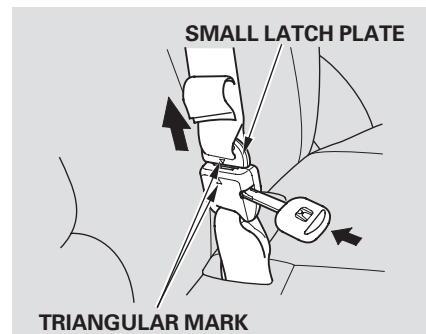

To unlatch the detachable anchor, insert a key into the slot on the side of the small buckle. Line up the triangle marks on the plate and buckle when reattaching the belt and buckle.

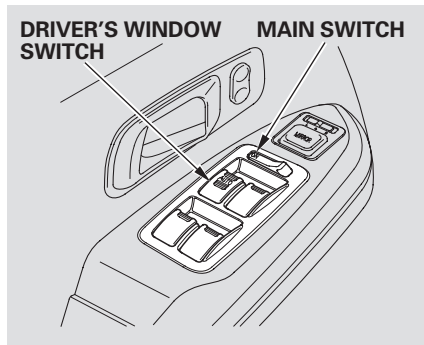

Turn the ignition switch to ON (II) to raise or lower any window. To open the window, push the switch down and hold it. Release the switch when you want the window to stop. Pull back on the switch and hold it to close the window.

### **⚠ WARNING**

Closing a power window on someone's hands or fingers can cause serious injury.

Make sure your passengers are away from the windows before closing them.

**AUTO** — To open/close the driver's window, push the window switch firmly down or up to the second detent, and release it. The window will automatically go up or down all the way. To stop the window, pull/push on the window switch briefly.

If the MAIN switch is OFF, the passenger windows cannot be raised or lowered. Keep the MAIN switch off when you have children in the vehicle so they do not injure themselves by operating the windows unintentionally.

**AUTO REVERSE** — If the driver's window runs into any obstacle while it is closing automatically, it will reverse direction and then stop. To close the window, remove the obstacle, then use the window switch again.

If your vehicle's battery is disconnected or goes dead, or the driver's window fuse is removed, the AUTO function will be disabled. The power window system needs to be reset after reconnecting the battery or installing the fuse.

1. Start the engine. Push down and hold the driver's window switch until the window is fully open.
2. Pull and hold the driver's window switch to close the window completely, then hold the switch for a second or two more.

If the power windows do not operate properly after resetting, have your vehicle checked by a Honda dealer.

## Mirrors

Keep the inside and outside mirrors clean and adjusted for best visibility. Be sure to adjust the mirrors before you start driving.

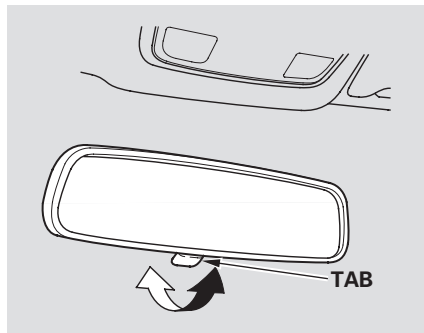

The inside mirror has day and night positions. The night position reduces glare from headlights behind you. Flip the tab on the bottom edge of the mirror to select the day or night position.

### Adjusting the Power Mirrors

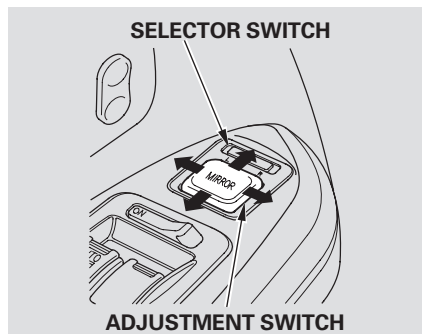

1. Move the selector switch to L (driver's side) or R (passenger's side).
2. Push the appropriate edge of the adjustment switch to move the mirror right, left, up, or down.
3. When you finish, move the selector switch to the center (off) position. This turns off the adjustment switch so you can't move a mirror out of position by accidentally bumping the switch.

### Power Mirror Heaters (If equipped)

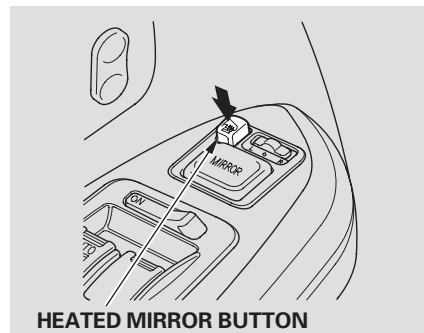

The outside mirrors are heated to remove fog and frost. With the ignition switch in the ON (II) position, turn on the heaters by pressing the button. The indicator in the button comes on as a reminder. Press the button again to turn the heaters off.

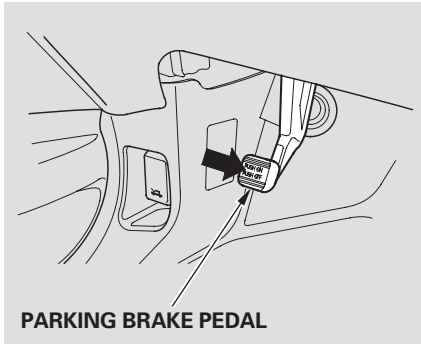

**NOTICE:** *Driving the vehicle with the parking brake applied can damage the rear brakes and axles.*

To apply the parking brake, push the parking brake pedal down with your foot. To release the parking brake, push on the pedal again. The parking brake light on the instrument panel should go out when the parking brake is fully released with the engine running. (see page [49](#).)

## Interior Convenience Items

---

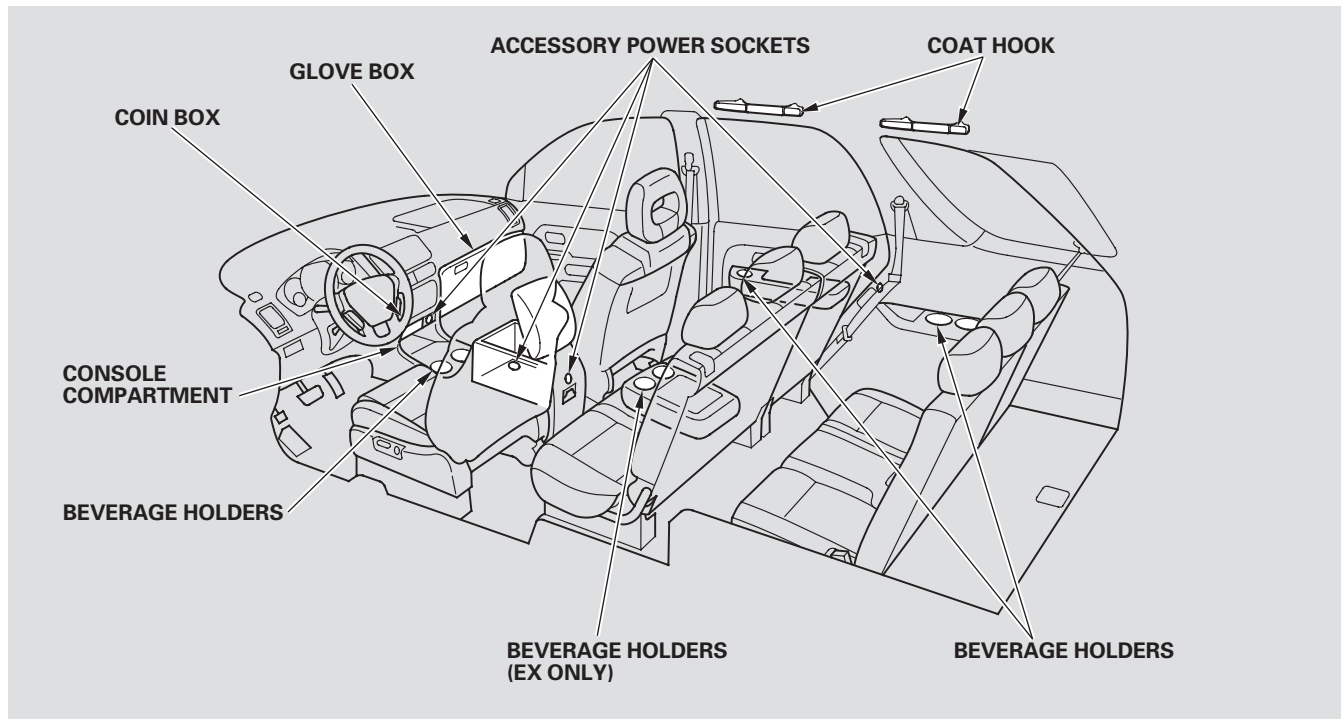



### Beverage Holders

Be careful when you are using the beverage holders. A spilled liquid that is very hot can scald you or your passengers. Liquid can also spill from the rear door pocket beverage holders when you close the rear doors. Use only resealable containers in the door pockets. The front beverage holders can be installed under the slide.

Spilled liquids can damage the upholstery, carpeting, and electrical components in the interior.

### Accessory Power Sockets

These sockets are intended to supply power for 12 volt DC accessories that are rated 120 watts or less (10 amps).

None of the sockets will power an automotive type cigarette lighter element. When more than one socket is being used, the combined power rating of the accessories should be 120 watts or less (10 amps).

### Console Compartment

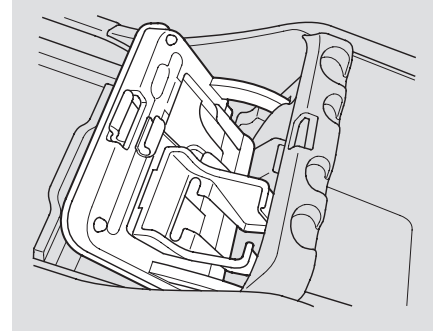

To open the console compartment, pull up on the lever and lift the lid.

Pivot the front door of the console forward and you can store a cellular phone, a small notepad, and business cards in it.

## Interior Convenience Items

### Sunglasses Holder



To open and close the sunglasses holder, push on the front edge. Make sure the holder is closed while you are driving. Some larger styles of sunglasses may not fit in the holder.

### Glove Box

Open the glove box by pulling the bottom of the handle. Close it with a firm push. Lock or unlock the glove box with the master key.

The glove box light comes on only when the parking lights are on.

#### **⚠ WARNING**

An open glove box can cause serious injury to your passenger in a crash, even if the passenger is wearing the seat belt.

Always keep the glove box closed while driving.

### Sun Visor

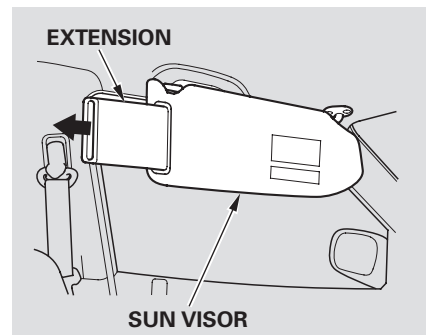

When using the sun visor for the side window, remove the support rod from the clip and swing it out. Slide the extension out to get more coverage on side windows.

Make sure you put the sun visor back in place when you are getting into or out of the vehicle. Do not use the sun visor extension over the rear view mirror.

## Light Control Switch

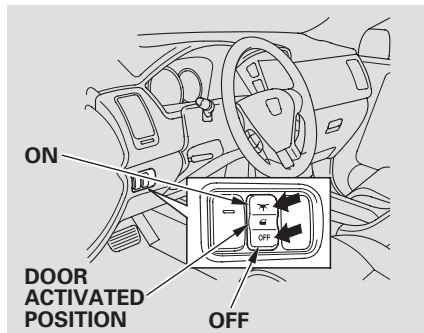

*When this switch is in the ON position:*

- All the individual map lights come on.

*When this switch is in the OFF position:*

- None of the lights come on when a door or the tailgate is opened.
- The individual map lights in the front can be turned on and off with the switches next to the lights.

- The individual map lights in the second and third rows cannot be turned on.

*When the switch is in the Door Activated position:*

- The individual map lights come on when any door or the tailgate is opened, or when the remote transmitter is used to unlock the doors.
- The individual map lights in the second and third rows can be turned on and off by pressing the lens.
- The tailgate light comes on when you open the tailgate if the light switch is in the ON position.
- The lights go out about 6 seconds after all the doors and the tailgate are closed. With any door or the tailgate left open, the lights stay on about 3 minutes, then go out.

## *Individual Interior Lights*

The courtesy lights in the front doors and around the ignition switch come on when you open any door. After you close the door, the ignition switch light stays on for several seconds.



## Comfort and Convenience Features

---

Vents, Heating, and A/C .....	82	Setting the Clock .....	103
Air Flow Buttons.....	83	Rear Entertainment System.....	104
Climate Control.....	86	DVD Specifications .....	112
Playing the Radio.....	88	Security System .....	115
Radio Reception.....	91	Cruise Control.....	116
Playing a CD.....	93	HomeLink Universal	
CD Changer .....	94	Transceiver.....	118
Protecting your CDs.....	95		
CD Player Error Messages .....	96		
CD Changer Error Messages ....	97		
Playing a Tape.....	98		
Steering Wheel Controls .....	101		
Radio Theft Protection.....	102		

## Vents, Heating, and A/C

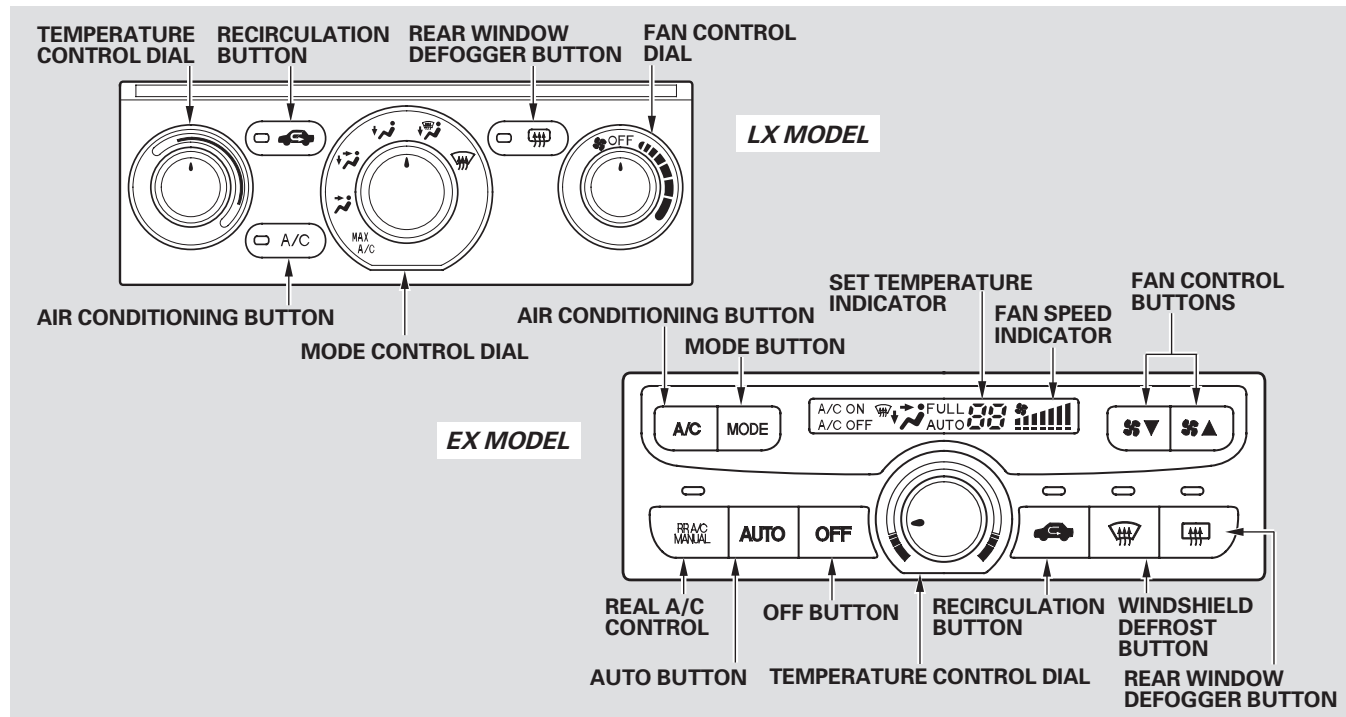

### Fan Control

*On LX models*, turn this dial clockwise to increase fan speed and increase the airflow.

*On EX models*, you can manually select the fan speed by pressing the fan control buttons. The fan speed is represented by vertical bars in the display.

### Temperature Control Dial

Turning this dial clockwise increases the temperature of the airflow.

### Air Conditioning (A/C) Button

This button turns the air conditioning on and off. The light in the button is on when the A/C is on.

*On EX models*, you will see A/C ON or A/C OFF in the display. When you turn the A/C off, the system cannot regulate the inside temperature if you set the dial below the outside temperature.

### Recirculation Button

When the light in the button is on, air from the vehicle's interior is sent throughout the system again. When the light is off, air is brought in from the outside of the vehicle (Fresh Air mode).

The outside air intakes for the heating and cooling system are at the base of the windshield. Keep this area clear of leaves and other debris.

The system should be left in Fresh Air mode under almost all conditions. Keeping the system in Recirculation mode, particularly with the A/C off, can cause the windows to fog up.

Switch to Recirculation mode when driving through dusty or smoky conditions, then return to Fresh Air mode.

### Rear Window Defogger Button

This button turns the rear window defogger off and on (see page 60).

### Mode Control

Use the mode control dial or buttons to select the vents the air flows from. Some air will flow from the dashboard corner vents in all modes.

 Air flows from the center and corner vents in the dashboard.

 Air flow is divided between the vents in the dashboard and the floor vents.



 Air flows from the floor vents.

 Air flow is divided between the floor vents and the defroster vents at the base of the windshield.

## Air Flow Buttons, Vents, Heating, and A/C

---

 Air flows from the defroster vents at the base of the windshield.

When you select  or , the system automatically switches to Fresh Air mode and turns on the A/C. In this case you cannot turn A/C mode off.

When you select , the system automatically switches to Fresh Air mode and turns on the A/C.

### Ventilation

The flow-through ventilation system draws in outside air, circulates it through the interior, then exhausts it through vents near the rear side panels.

1. Turn the temperature control dial all the way to the left.
2. Make sure the A/C is off.
3. Select  and Fresh Air mode.
4. Set the fan to the desired speed.

### Using the Heater

The heater uses engine coolant to warm the air. If the engine is cold, it will be several minutes before you feel warm air coming from the system.

1. Select  and Fresh Air mode.
2. Set the fan to the desired speed.
3. Adjust the warmth of the air with the temperature control dial or buttons.

### Using the A/C

Air conditioning places an extra load on the engine. Watch the engine coolant temperature gauge (see page 55). If it moves near the red zone, turn off the A/C until the gauge reads normally.

1. Turn on the A/C by pressing the button. The light in the button comes on when a fan speed is selected.
2. Make sure the temperature control dial is all the way to the left.
3. Select .
4. If the outside air is humid, select Recirculation mode. If the outside air is dry, select Fresh Air mode.
5. Set the fan to the desired speed.

*If the interior is very warm, you can cool it down more rapidly by partially opening the windows, turning on the A/C, and setting the fan to maximum speed in Fresh Air mode.*

**NOTE:** The vehicle has two A/C and heater units. The LX units are independently controlled. The EX units are controlled by the front panel controls, unless the RR A/C Manual button is selected.



### Dehumidify the Interior



Air conditioning, as it cools, removes moisture from the air. When used in combination with the heater, it makes the interior warm and dry.

1. Switch the fan on.
2. Turn on the air conditioning.
3. Select  and Fresh Air mode.
4. Adjust the temperature control dial to your preference.

This setting is suitable for all driving conditions whenever the outside temperature is above 32°F (0°C).



### To Defog and Defrost

To remove fog from the inside of the windows:

1. Set the fan to the desired speed.
2. Select . When you select , the system automatically switches to Fresh Air mode and turns on the A/C.
3. Adjust the temperature control dial so the airflow feels warm.
4. Select  to help clear the rear window.

When you switch to another mode from , the A/C stays on. Press the A/C button to turn it off.

### To Remove Exterior Frost or Ice From the Windows

1. Select . The system automatically switches to Fresh Air mode and turns on the A/C.
2. Select .
3. Set the fan and temperature controls to maximum level.

To clear the windows faster, you can close the dashboard corner vents by rotating the wheel below it. This will send more warm air to the windshield defroster vents. Once the windshield is clear, select the Fresh Air mode to avoid fogging the windows.

For your safety, make sure you have a clear view through all the windows before driving.

## Climate Control

---

### To Cool or Heat Automatically

*On EX models*

The Automatic Climate Control system can adjust the fan speed and airflow levels to maintain the interior temperature you select.

### Using Automatic Climate Control

1. Press the AUTO button.
2. Set the desired temperature by turning the Temperature Control dial. You will see FULL AUTO in the system's display.

The system automatically selects the proper mix of conditioned and/or heated air that will, as quickly as possible, raise or lower the interior temperature to your preference.

When you set the temperature to its lower or its upper limit, the system runs at full cooling or heating only. It does not regulate the interior temperature.

When you press a fan control button, the fan is taken out of FULL AUTO mode and starts to run at its lowest speed. Press the ▲ button repeatedly to make the fan run faster.

*Rear A/C Control* – When the system is in FULL AUTO, the rear A/C passenger control dial cannot be used. Pressing the RR A/C button disables the FULL AUTO function.

### Semi-automatic Operation

You can manually select various functions of the Climate Control system when it is in FULL AUTO. All other features remain automatically controlled. Making any manual selection causes the word FULL in the display to go out. See page 82 .

### To Turn Everything Off

Press the OFF button. However, a lack of air flow can cause the windows to fog up. It is recommended that you keep the fan on at all times so stale air and moisture do not build up in the interior and cause fogging.

## Using the Rear A/C Unit

*EX models*

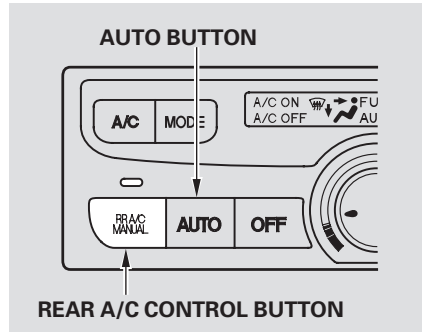

Press the RR A/C button to enable the rear A/C control knob. A passenger in the second row can use the rear control dial to adjust the temperature up to 21°F (10°C) higher or lower than the front. This is limited by the minimum and maximum system temperatures.

## Sunlight and Temperature Sensors

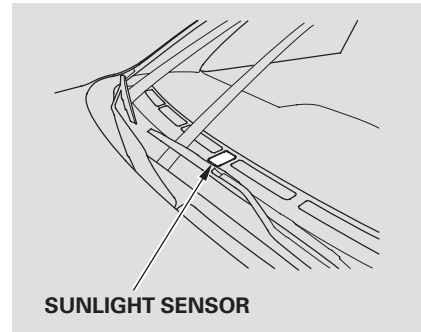

The climate control system has two sensors. A sunlight sensor is in the top of the dashboard, and a temperature sensor is next to the steering column. Do not cover the sensors or spill any liquid on them.

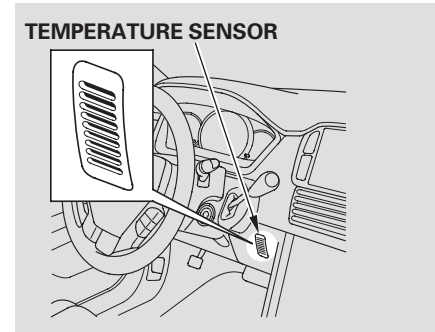

# Playing the Radio

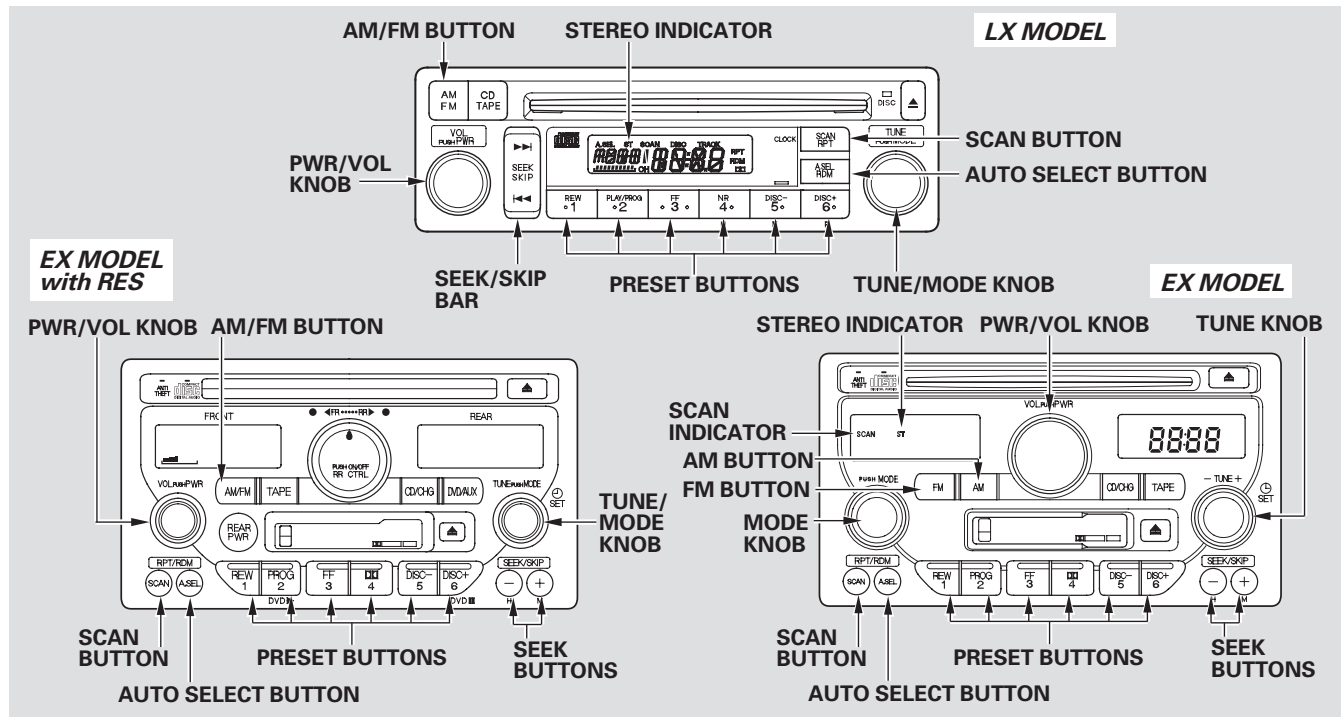

### To Play the Radio

The ignition switch must be in the ACCESSORY (I) or ON (II) position. Turn the system on by pushing the PWR/VOL knob or the AM/FM button. Adjust the volume by turning the same knob.

The band and frequency that the radio was last tuned to is displayed. To change bands, press the AM/FM button. On the FM band, ST will be displayed if the station is broadcasting in stereo. Stereo reproduction on AM is not available.

### To Select a Station

You can use any of five methods to find radio stations on the selected band: **TUNE**, **SEEK**, **SCAN**, the preset buttons, and **AUTO SELECT**.

**TUNE** – Use the TUNE knob to tune the radio to a desired frequency. Turn the knob right to tune to a higher frequency, or left to tune to a lower frequency.

**SEEK** – The SEEK function searches up and down from the current frequency to find a station with a strong signal. To activate it, press the **◀◀ /(-)** or **▶▶ /(+)** side of the bar, then release it.

**SCAN** – The SCAN function samples all stations with strong signals on the selected band. To activate it, press the SCAN button, then release it. You will see SCAN in the display. The system will scan for a station with a strong signal. When it finds one, it will stop and play that station for about five seconds.

If you do nothing, the system will then scan for the next strong station and play it for five seconds. When it plays a station you want to listen to, press the SCAN button again.

**Preset** – Each preset button can store one frequency on AM, and two frequencies on FM.

1. Select the desired band, AM or FM. FM1 and FM2 let you store two frequencies with each preset button.
2. Use the TUNE, SEEK, or SCAN function to tune the radio to a desired station.
3. Pick a preset button, and hold it until you hear a beep.
4. Repeat steps 1 to 3 to store a total of six stations on AM and twelve stations on FM.

The preset frequencies will be lost if your vehicle's battery goes dead, is disconnected, or the radio fuse is removed.

*CONTINUED*

## Playing the Radio

---

**AUTO SELECT** — If you are traveling far from home and can no longer receive your preset stations, you can use the Auto Select feature to find stations in the local area.

Press the A. SEL Button. “A.SEL” flashes in the display, and the system goes into scan mode for several seconds. It stores the frequencies of six AM, and twelve FM stations in the preset buttons.

You will see a “0” displayed after pressing a preset button if Auto Select cannot find a strong station for every preset button.

If you do not like the stations Auto Select has stored, you can store other frequencies on the preset buttons. Use the TUNE, SEEK, or SCAN function to find stations, then store them in the preset buttons as described previously.

*To turn off Auto Select, press the A. SEL button. This restores the presets you originally set.*

### Adjusting the Sound

Press the MODE knob repeatedly to display the Bass (BAS), Treble (TRE), Balance (BAL), and Fader (FAD) settings.

Each mode is shown in the display as it changes. Turn the MODE knob to adjust the setting to your liking. When the level reaches the center, you will see “C” in the display. The system will automatically return the display to the selected audio mode about five seconds after you stop adjusting a mode.

**Balance/Fader** — These two modes adjust the strength of the sound coming from each speaker. BAL adjusts the side-to-side strength, while FAD adjusts the front-to-back strength.

**Treble/Bass** — Use the TRE/BAS modes to adjust the tone to your liking.

### Audio System Lighting

You can use the instrument panel brightness control knob to adjust the illumination of the audio system (see page 59). The audio system illuminates when the parking lights are on, even if the radio is off.

### Radio Frequencies

Your Honda's radio can receive the complete AM and FM bands. Those bands cover these frequencies:

AM band:

530 to 1,710 kilohertz

FM band:

87.7 to 107.9 megahertz

Radio stations on the AM band are assigned frequencies at least ten kilohertz apart (530, 540, 550). Stations on the FM band are assigned frequencies at least 0.2 megahertz apart (87.9, 88.1, 88.3).

Stations must use these exact frequencies. It is fairly common for stations to round-off the frequency in their advertising, so your radio could display a frequency of 100.9 even though the announcer may identify the station as "FM101."

### Radio Reception

How well your Honda's radio receives stations is dependent on many factors, such as the distance from the station's transmitter, nearby large objects, and atmospheric conditions.

A radio station's signal gets weaker as you get farther away from its transmitter. If you are listening to an AM station, you will notice the sound volume becoming weaker, and the station drifting in and out. If you are listening to an FM station, you will see the stereo indicator flickering off and on as the signal weakens. Eventually, the stereo indicator will go off and the sound will fade completely as you get out of range of the station's signal.

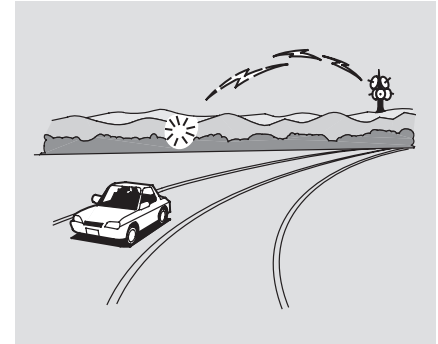

Driving very near the transmitter of a station that is broadcasting on a frequency close to the frequency of the station you are listening to can also affect your radio's reception. You may temporarily hear both stations, or hear only the station you are close to.

*CONTINUED*

## Radio Reception

---

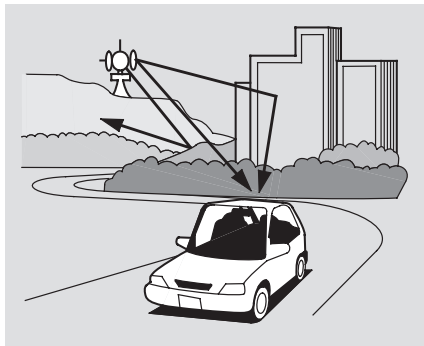

Radio signals, especially on the FM band, are deflected by large objects such as buildings and hills. Your radio then receives both the direct signal from the station's transmitter, and the deflected signal. This causes the sound to distort or flutter. This is a main cause of poor radio reception in city driving.



Radio reception can be affected by atmospheric conditions such as thunderstorms, high humidity, and even sunspots. You may be able to receive a distant radio station one day and not receive it the next day because of a change in conditions.

Electrical interference from passing vehicles and stationary sources can cause temporary reception problems.

*As required by the FCC:  
Changes or modifications not expressly  
approved by the party responsible for  
compliance could void the user's  
authority to operate the equipment.*



# Playing a CD

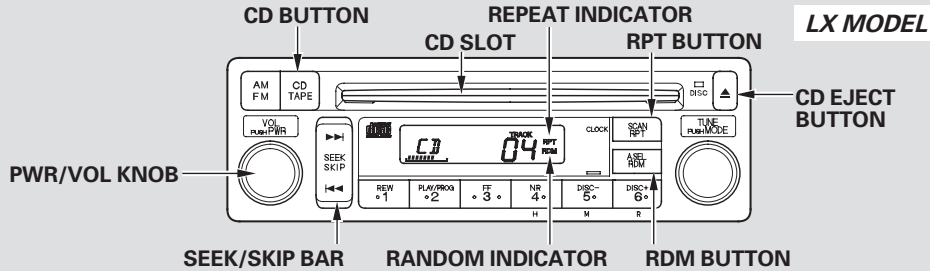

**EX MODEL with RES**

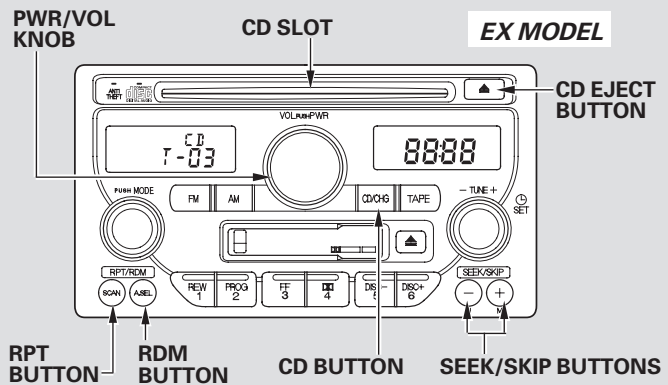
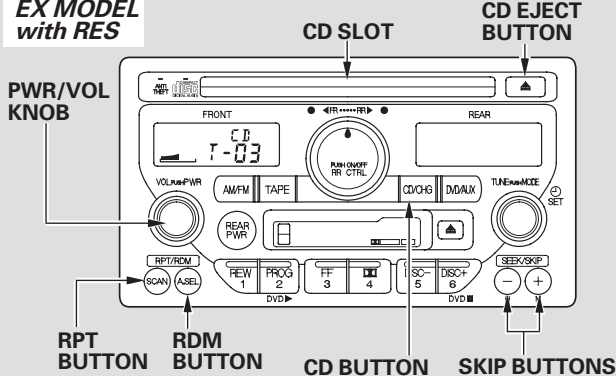

## Playing a CD, CD Changer

---

### To Play a CD

With the ignition in the ACCESSORY (I) or ON (II) position, insert a CD into the CD slot. The drive will pull the CD in the rest of the way and begin to play it.

You operate the CD player with the same controls used for the radio. The number of the track playing is shown in the display. The system will continuously play a CD until you change modes.

### To Change Tracks (SKIP)

Each time you press and release **▶▶** /(+), the player skips forward to the beginning of the next track. Press and release **◀◀** /(-) to skip backward to the beginning of the previous track.

To move rapidly within a track, press and hold the **▶▶** /(+), or **◀◀** /(-). You will see CUE or REW in the display.

**REPEAT** — To continuously replay a track, press and release the RPT button. You will see RPT in the display. Press the RPT button again to turn it off.

**RANDOM** — This feature plays the tracks in random order. To activate Random Play, press and release the RDM button. You will see RDM in the display. This continues until you press the RDM button again.

### To Stop Playing a CD

Press the eject button ( **▲** ) to remove the CD. If you eject the CD, but do not remove it from the slot, the system will automatically reload the CD after 15 seconds and put it in pause mode. To begin playing, press the CD button.

Press the AM/FM button to switch to the radio while a CD is playing. Press the CD button to play the CD.

If you turn the system off while a CD

is playing, either with the PWR/VOL knob or by turning off the ignition, the CD will stay in the drive. When you turn the system back on, the CD will begin playing where it left off.

### Operating the Optional CD Changer

A CD changer is available for your vehicle. It holds up to six CDs. You operate the CD changer with the same controls used for the in-dash CD player.

Load the desired CDs in the magazine, and load the magazine in the changer according to the instructions that came with the unit. To select the CD changer, press the CD button. The CD and track numbers will be displayed. To select a different CD, use the preset 5 (DISC -) or preset 6 (DISC +) button. If you select an empty slot in the magazine, the changer will, after finding that slot empty, try to load the CD in the next slot.

### General Information

- When using CD-R discs, use only high quality CDs labeled for audio use.
- When recording a CD-R, the recording must be closed for it to be used by the CD players.
- CD-RW discs will not work in this unit.
- Play only standard round CDs. Odd-shaped CDs may jam in the drive or cause other problems.
- Handle your CDs properly to prevent damage and skipping. See this page.

### Protecting CDs

When a CD is not being played, store it in its case to protect it from dust and other contamination. To prevent warpage, keep CDs out of direct sunlight and extreme heat.

To clean a CD, use a clean soft cloth. Wipe across the CD from the center to the outside edge.

A new CD may be rough on the inner and outer edges. The small plastic pieces causing this roughness can flake off and fall on the recording surface of the CD, causing skipping or other problems. Remove these pieces by rubbing the inner and outer edges with the side of a pencil or pen.

Never try to insert foreign objects in the CD player or the magazine.

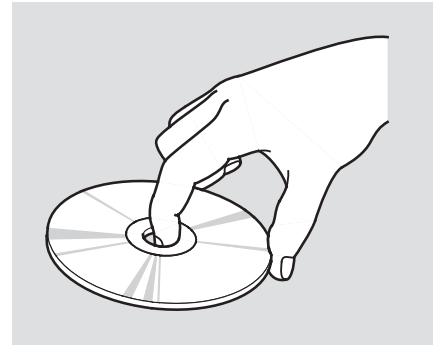

Handle a CD by its edges; never touch either surface. Do not place stabilizer rings or labels on the CD. These, along with contamination from fingerprints, liquids, and felt-tip pens, can cause the CD to not play properly, or possibly jam in the drive.

## CD Player Error Messages

---

If you see an error message in the display while playing a CD, find the cause in the chart to the right. If you cannot clear the error message, take your vehicle to a Honda dealer.

Error Message	Cause	Solution
<i>CD DISC</i>	FOCUS Error	Press the EJECT button and pull out the CD. Check if it is inserted correctly in the CD player. Make sure the CD is not scratched or damaged.
<i>CD ERR</i>	Mechanical Error, or a DVD has been loaded in the CD player	Press the EJECT button and pull out the CD. Check the CD for damage or deformation. If the CD cannot be pulled out, or the error message does not disappear after the CD is ejected, see a Honda Dealer.
<i>CD HOT</i>	High Temperature	Will disappear when the temperature returns to normal.

## CD Changer Error Messages

If you see an error message in the display while playing a CD, find the cause in the chart to the right. If you cannot clear the error message, take your vehicle to a Honda dealer.

Error Message	Cause	Solution
CD DISC	FOCUS Error	Press the magazine EJECT button and pull it out. Check for an error message, and insert the magazine again. If the message does not disappear or the magazine cannot be pulled out, see a Honda dealer.
	No CD in the CD magazine	Insert a CD.
CD ERR	Mechanical Error	Press the magazine EJECT button and pull it out. Check for an error message and insert the magazine again. If the message does not disappear or the magazine cannot be pulled out, see a Honda dealer.
CD Hot	High Temperature	Will disappear when the temperature returns to normal.
CD EJECT	No CD magazine in the CD changer.	Insert CD magazine.

# Playing a Tape

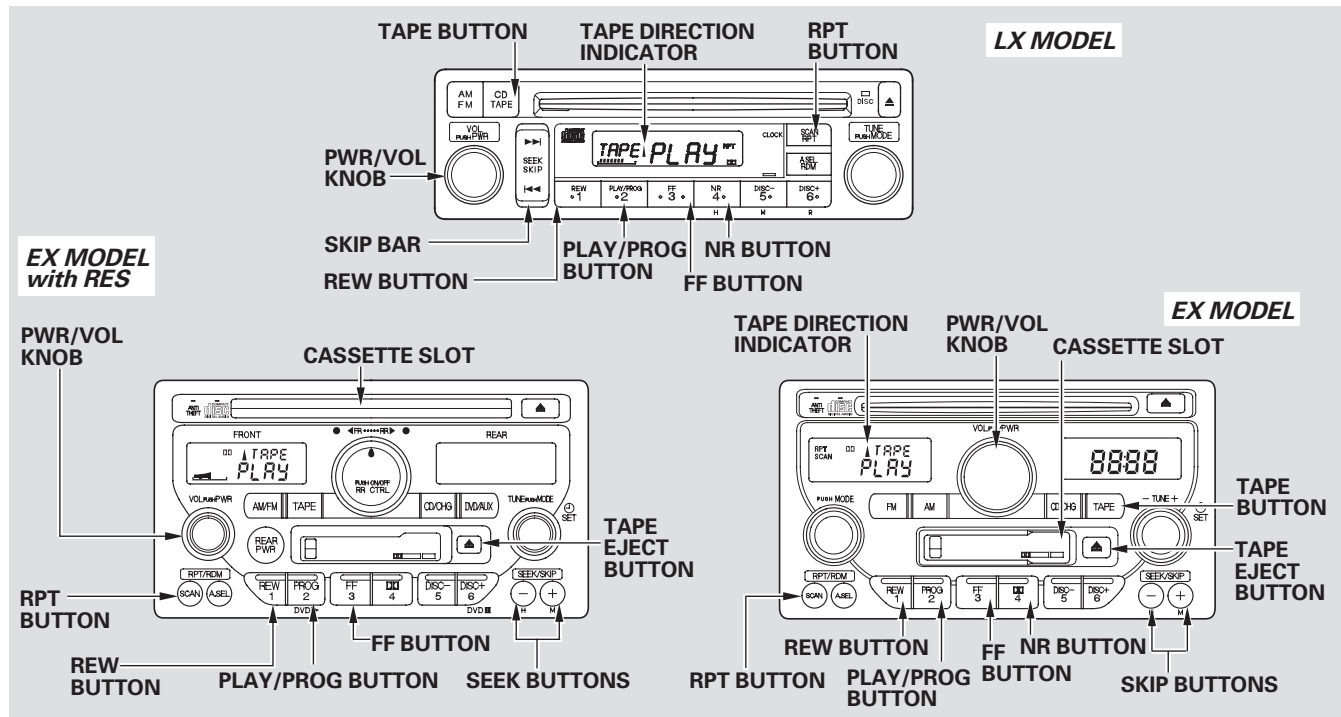



### To Play a Tape

#### *Optional on LX models*

The ignition switch must be in ACCESSORY (I) or ON (II). Make sure the open side of the tape is facing right, then insert the tape most of the way into the slot. The system will pull the tape in the rest of the way, and begin to play it.

The tape direction indicator will come on to show you which side of the tape is playing. The ▲ indicates the side you inserted upward in now playing. If you want to play the other side, press the PLAY/PROG button. When the player reaches the end of the tape, it will automatically reverse direction and play the other side.

Dolby\* noise reduction turns on when you insert a tape. The  indicator will light in the display. If the tape was not recorded in Dolby, turn it off by pressing the NR button. Dolby remains off until you press the NR button again.

\* Dolby noise reduction manufactured under license from Dolby Laboratories Licensing Corporation. "DOLBY" and the double-D symbol  are trademarks of Dolby Laboratories Licensing Corporation.

### To Stop Playing a Tape



To remove the tape, press the EJECT button. If you want to turn the player off, press the PWR/VOL knob or turn off the ignition. The tape will remain in the drive.

*LX Models* — When you turn the system back on, the tape player will be in pause mode. Press the PLAY/PROG button to resume play.

To switch to the radio or CD player while a tape is playing, press the AM/FM or CD/CHG (CD/TAPE) button. To change back to the tape player, press the TAPE button.

### Tape Search Functions

**FF/REW** — To rewind the tape, push the REW button. You will see REW in the display. To fast forward the tape, push the FF button. You will see FF displayed. Press the FF, REW, or PLAY/PROG button to take the system out of rewind or fast forward.

**SKIP** — Press the  / (-) buttons to find the beginning of the current song or passage. Press the  / (+) buttons to find the beginning of the next song or passage. When the system reaches the beginning of a song or passage, it begins to play it.

*CONTINUED*

## Playing a Tape

---

**REPEAT** — Press the RPT button to continuously play a song or passage. You will see RPT displayed. The track will repeat until you press the RPT button again.

**NOTE:** The SKIP and REPEAT functions use silent periods on the tape to find the end of a song or passage. These features may not work if there is almost no gap between selections, a high noise level, or a silent period in the middle of a selection.

### Caring for the Tape and Player

The tape player picks up dirt and oxides from the tape. This contamination builds up over time and cause the sound quality to degrade. To prevent this, you should clean the player after every 30 hours of use.

If you do not clean the tape player regularly, it may eventually become impossible to remove the contamination with a normal cleaning kit. Your Honda dealer has a cleaning kit available.

Use 100-minute or shorter tapes. Tapes longer than that may break or jam the drive.

If the tape is loose, tighten it by turning the hub with a pencil or your finger. If the label is peeling off, remove it or it could cause the cassette to jam in the player. Never try to insert a warped or damaged

cassette in the player.

Store tapes in their cases to protect them from dust and moisture. Never place tapes where they will be exposed to direct sunlight, high heat, or high humidity. If a tape is exposed to extreme heat or cold, let it reach a moderate temperature before inserting it into the player.

Never try to insert foreign objects into the cassette player.



### *EX Only*

Three controls for the audio system are mounted in the steering wheel hub. These let you control basic functions without removing your hand from the wheel.

The middle button adjusts the volume. Press the top or bottom of the button and hold it until the desired volume is reached, then release it.

The CH button has three functions, depending on whether you are listening to the radio, playing a tape, or CD.

The AM/FM functions change AM, FM1, FM2, CD, Tape, and DVD/AUX, if available.

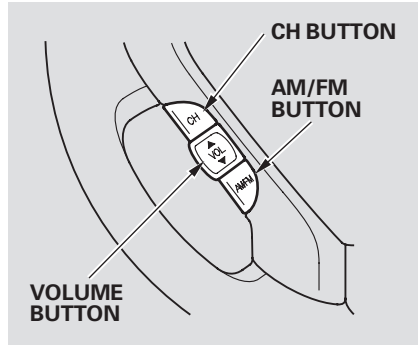

*If you are listening to the radio, use the CH button to go to the next preset station. You will see the number of the preset button in the display. To change bands, press the AM/FM button.*

*If you are playing a tape, use the CH button to advance to the next selection. You will see “FF” blinking in the display. The system fast forwards until it senses a silent period, then resumes playing.*

*If you are playing a CD, use the CH button to skip to the beginning of the next track. You will see the CD and track number in the display.*

## Radio Theft Protection

---

### *On EX models*

Your vehicle's audio system will disable itself if it is disconnected from electrical power for any reason. To make it work again, you must enter a specific five-digit code in the preset buttons. Because there are hundreds of number combinations possible from five-digits, making the system work without knowing the exact code is nearly impossible.

You should have received a card that lists your audio system code number and serial number. It is best to store this card in a safe place at home. In addition, you should write the audio system's serial number in this Owner's Manual.

If you should happen to lose the card, you must obtain the code number from a Honda dealer. To do this, you will need the system's serial number.

If your vehicle's battery is disconnected or goes dead, the audio system will disable itself. If this happens, you will see "CODE" in the frequency display the next time you turn on the system. Use the preset buttons to enter the five-digit code. The code is located on the radio code card included in your Owner's Manual kit. When it is entered correctly, the radio will start playing.

If you make a mistake entering the code, do not start over; complete the five-digit sequence, then enter the correct code. You have ten tries to enter the correct code. If you are unsuccessful in ten attempts, you must then leave the system on for 1 hour before trying again.

If the code card is lost, a Honda dealer can access your code with the your radio's serial number. To access the serial number, turn the radio on. It must display "CODE", then turn the radio off. Push the preset 1, preset 6, and power buttons at the same time, then quickly release.

You will have to store your favorite stations in the Preset buttons after the system begins working. Your original settings were lost when the power was disconnected.

## Setting the Clock

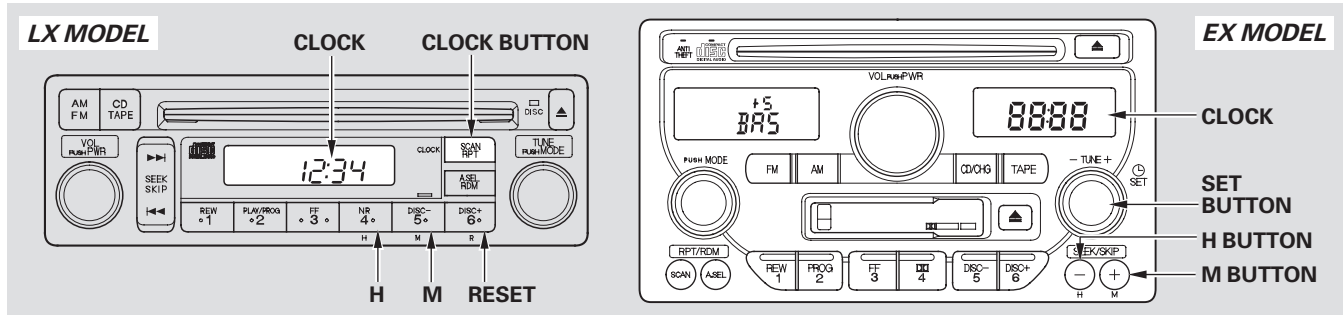

If your vehicle's battery is disconnected or goes dead, you will need to set the clock.

### *LX models*

Press and hold the **CLOCK** (SCAN/RPT) button. Change the hours by pressing the **H** (preset 4) button until the numbers advance to the desired time. Change the minutes by pressing the **M** (preset 5) button until the numbers advance to the desired time. When you are finished, release the **CLOCK** button.

You can quickly set the time to the nearest hour. If the displayed time is before the half hour, pressing and holding the clock button, then pressing the **RESET** (preset 6) button sets the clock back to the previous hour. If the displayed time is after the half hour, the clock sets forward to the beginning of the next hour.

For example: 1:06 will reset to 1:00  
1:52 will reset to 2:00

### *EX models*

The right display shows the time when the ignition is in the **ACCESSORY (I)** or **ON (II)** position. Press and hold the **SET** (TUNE) button until the numbers flash. Change the hours by pressing the **H** (-) button until the numbers advance to the desired time. Change the minutes by pressing the **M** (+) button until the numbers advance to the desired time. When you are finished, press the **SET** button again.

## Rear Entertainment System

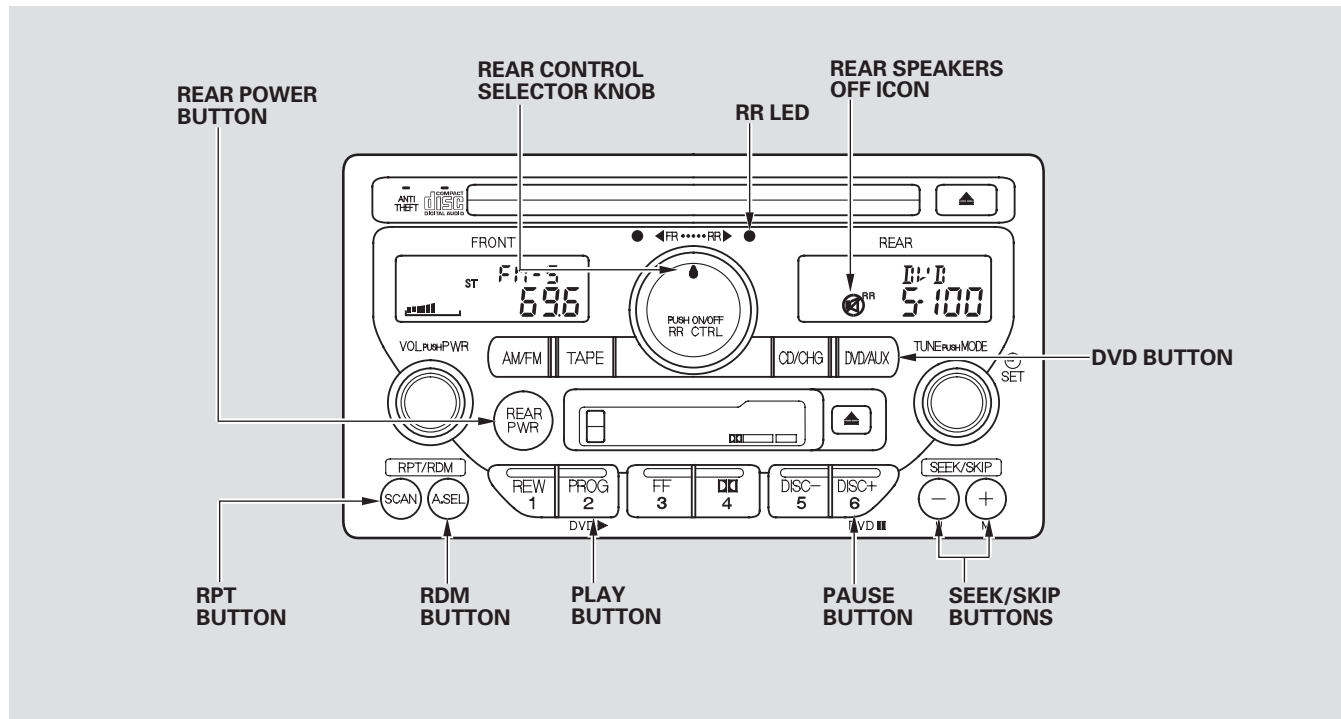

### *Optional on EX models*

With this system, the rear passengers can enjoy a different entertainment source (radio, tape player, CD player, or DVD player) than the front seat occupants. The audio is broadcast through the supplied wireless headphones.

### **To Turn On the System**

Press the REAR PWR button. To turn on the rear controls (ceiling panel or remote), press the RR CTRL knob. The system's icon shows in the right side display. Your passengers can then operate the rear system with the control panel in the ceiling or with the remote control. Press the RR CTRL knob again to turn the rear controls off. The rear system selects the source it was last set to. If that source has been removed (the DVD has been ejected from the player, for example), you will see “\_ \_ \_ \_” in the display. You must select another source.

### **Rear Speakers**

When you turn on the system, the rear speakers are automatically turned off. You will see the Rear Speakers Off icon in the display. The sound for the rear system is sent to the wireless headphones.

If you want to turn the rear speakers on again, press and hold the REAR PWR button until the Rear Speakers Off icon goes off.

**NOTE:** The rear speakers are connected to the front system, so they will always play the source that the front system is set to.

### **To Select Rear Entertainment from the Front Control Panel**

To operate the rear entertainment system from the front panel, turn the RR CTRL knob clockwise. The amber RR LED comes on to show that the control panel is enabled.

To play the radio or tape, the buttons for the front entertainment system have the same functions.

If a CD is loaded in the main CD player or CD changer, select CD/CHG. If the CD is loaded in the lower player, select DVD/AUX.

If the CD is loaded in the main CD player or CD changer, refer to page [94](#) for operating instructions. If the CD is loaded in the DVD/AUX player, refer to page [107](#).

## Rear Entertainment System

---

### Operating the DVD Player from the Front Control Panel

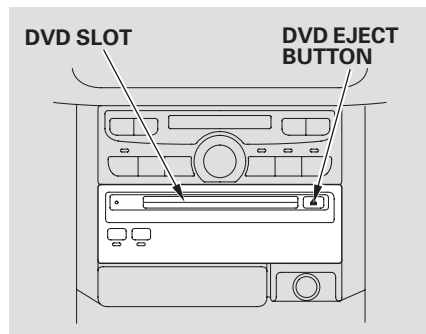

Turn the RR CTRL knob clockwise. The amber RR LED will come on to show that the control panel is now enabled.

Insert a DVD into the DVD/CD player below the front panel.

**PLAY** — Press the PLAY button if the DVD does not start playing automatically.

**PAUSE** — Press the PAUSE button to pause the DVD. Press the button again or press PLAY to resume. Pause works only with the DVD player.

**SEEK/SKIP** — Press and hold the (+) button to move forward; you will see “CUE” in the display. Press and hold the (–) side to move backward; you will see “REV” in the display. Release the button when the system reaches the point you want.

Each time you press and release the (+) button, the system skips forward to the next track or chapter. Press and release the (–) button to skip backward to the beginning of the current track or chapter. Press it again to skip to the beginning of the previous track or chapter.

**EJECT** — Press the eject button to remove the DVD from the drive.

### To Return to Front Audio Controls

To return front panel control to the front audio system, turn the RR CTRL knob counterclockwise.

### Using the Rear Control Panel

Use these buttons to select the entertainment source (radio, tape player, CD player, or DVD player/Auxiliary device). The selected source will be shown in the display. Make sure the rear control operation has not been disabled with the RR CTRL knob on the front panel.

### To Play the Radio from the Rear Control Panel

Use the ◀ and ▶ buttons to select from the stations on the rear control panel set to the preset buttons. Pressing the ⏪ or ⏩ button will cause the system to search up or down the band for a station with a strong signal. You will see SEEK in the display.

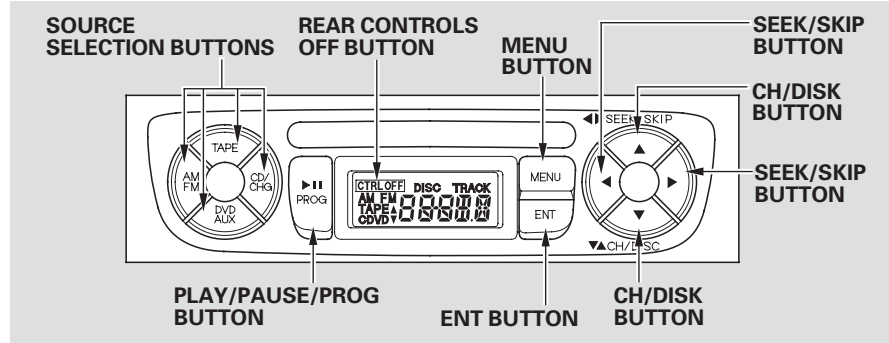

### To Play a Tape from the Rear Control Panel

On the rear control panel, use the PROG/PLAY button to reverse the tape direction. Press the ▶ button to skip forward to beginning of the next song or passage. You will see FF flashing in the display. Press the ◀ button to skip backward to the beginning of the current song or passage. You will see REV flashing in the display.

### To Play a CD from the Rear Control Panel

If a CD is loaded in the main CD player or CD changer, select it by pressing the CD/CHG button. If the CD is loaded in the DVD player, press the DVD/AUX button. Press the ▶ button to skip to the beginning of the next track. Press the ▲ button to return to the beginning of the current track. If the changer is selected, use the ▼ and ▲ buttons to change discs.

## Rear Entertainment System



---





### To Play a DVD from the Rear Control Panel

The video screen is for use by rear seat passengers only. The driver and front seat passenger should not try to view the screen while driving.

Open the overhead screen by pushing the open button. The screen will swing down partway. Pivot the screen the rest of the way. If you pivot the screen past the detent, the display will turn off. To close the screen, pivot it up until it latches.

**PLAY/PAUSE/PROG** – Press this button when you want to pause the DVD. Press this button again to go back to PLAY.

**SEEK/SKIP** – Press the  button to skip to the beginning of the next chapter. Press the  button to skip back to the beginning of the current chapter.

**MENU/ENT** – To select the menu on the DVD, press the MENU button. Use the , , , and  buttons to move to the desired menu selection, then press the ENT button to enter your selection.



## Using the Remote Control

You can use the remote control to select the entertainment source (radio, tape player, CD player, or DVD player/Auxiliary device). The selected source will be shown in the display.

Make sure the rear control operation has not been disabled with the RR CTRL knob on the front panel.

When using the remote control, point it at the rear control panel in the ceiling.

## To Play a Tape, CD, or Radio

The PLAY/PROG, PAUSE, STOP, SKIP, and FWD/REW buttons work the same as the front and rear control panel buttons.

## To Play a DVD

The PLAY/PROG, PAUSE, STOP, SKIP, and FWD/REW buttons work the same function as the front and rear control panel buttons.

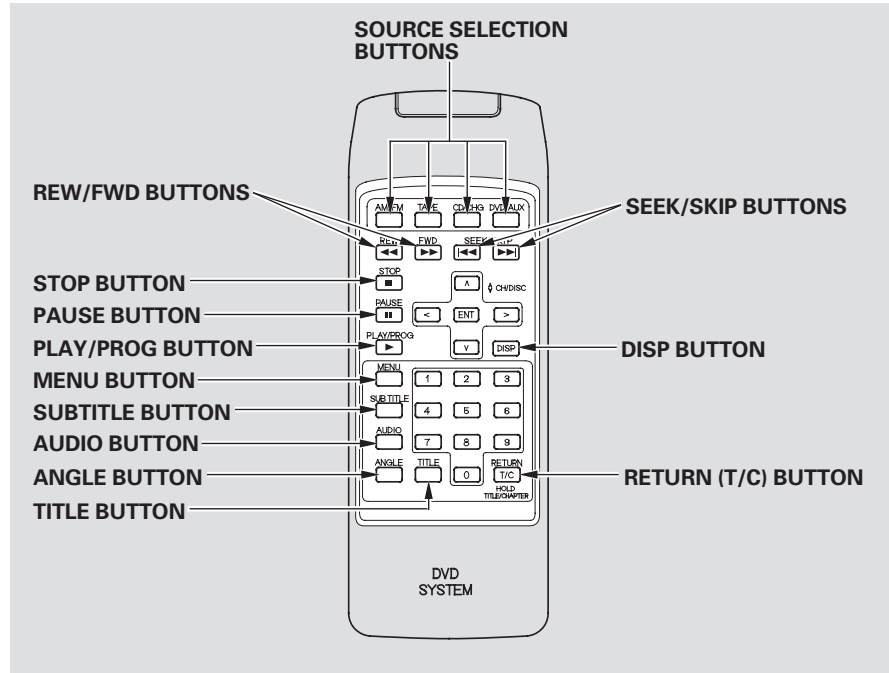

CONTINUED

## Rear Entertainment System

---

**MENU and TITLE Buttons** – Some DVDs have menus that allow you to select a dubbed language, subtitles, a chapter list, previews, etc. The menu contents will vary from DVD to DVD.

Use the ◀, ▶, ▲, and ▼ buttons to select the desired menu option. Then press ENT to enter your selection. Use the ◀◀ and ▶▶ buttons to change pages. You can also use the numbered buttons to enter the two-digit number of a menu option. You do not have to press ENT. Press the button again to close the window.

**SUBTITLES and AUDIO Buttons** – Many DVDs are recorded with subtitles or dubbed in multiple languages. To select subtitles, press the SUBTITLE button. To select a different language than the one being heard, press the AUDIO button. Continue to press and

release the SUBTITLE or AUDIO button to scan through all available languages.

**DISP Button** – To change the color, contrast, aspect ratio, and brightness of the video screen, press the DISP button. The current setting of one will be displayed on the screen each time you press the button. Use the ▶ and

◀ buttons to change the setting as desired. The display will disappear from the screen several seconds after you stop adjusting the setting.

**ANGLE Button** – On some DVDs, the scenes are recorded by more than one camera, giving different viewpoints of the same scene. By pressing the ANGLE button, you can select a different viewpoint.

**RETURN (T/C) Button** – In the MENU selection mode, pressing the RETURN button for less than two seconds changes the MENU display to the previous page. Pressing the RETURN button for more than two seconds while a DVD is playing brings the system into the TITLE enter mode. When you enter your selection, the DVD player will start playing from the selected title.

### Storing the Remote Control

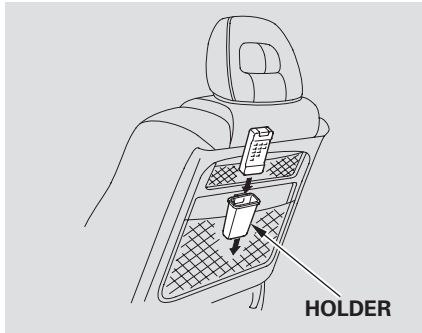

When you are not using the remote control, store it in its holder in the front seat pocket.

### Replacing the Remote Control Batteries

To replace the batteries in the remote control, press down on the ▼ symbol on the back, then slide the cover off. Remove the old batteries. Make sure the polarity of the new batteries is correct when you install them. Slide the cover until it locks. The remote control uses two AA batteries.

*As required by the FCC: This device complies with Part 15 of the FCC rules. Operation is subject to the following two conditions: (1) This device may not cause harmful interference, and (2) this device must accept any interference received, including interference that may cause undesired operation.*

*Changes or modifications not expressly approved by the party responsible for compliance could void the user's authority to operate the equipment. This device complies with Industry Canada Standard RSS-210. Operation is subject to the following two conditions: (1) this device may not cause interference, and (2) this device must accept any interference that may cause undesired operation of the device.*

## DVD Specifications

### Playable DVDs



There are various types of DVDs available. Some of them are not compatible with your system. The DVD player in your Rear Entertainment System can play DVDs and CDs bearing the above marks on their packages or jackets. Those packages or jackets should also bear the designation of “1” or “ALL”. DVD-ROMs cannot be played in this system.

### DVD Player Error Messages

If you see an error message in the display while operating the DVD player, find the cause in the chart to the right. If you cannot clear the message, take your vehicle to a Honda dealer.

Error Message	Cause	Solution
	FOCUS Error	Press the EJECT button and pull out the DVD. Check if it is inserted correctly in the DVD Player. Make sure the DVD is not scratched or damaged.
	Mechanical Error, or a DVD has been loaded in the CD player	Press the EJECT button and pull out the DVD. Check it for damage or deformation. If the DVD cannot be pulled out, or the error message does not disappear after the DVD is ejected, see a Honda dealer. Do not try to force the DVD out of the player.
	High Temperature	Will disappear when the temperature returns to normal.
	Low Vehicle Battery Voltage	Run the engine to recharge the battery.

### Wireless Headphones

Some state and local government agencies prohibit the use of headphones by the driver of a motor vehicle. Always obey applicable laws and regulations.

The audio for the rear entertainment system is sent to the wireless headphones that come with the system. To turn on the headphones, press the red button on the earpiece. Adjust the volume level with the dial at the bottom of the same earpiece.

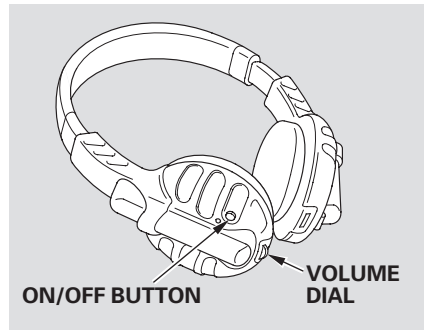

To adjust the headphones, slide the earpieces up or down the headband.

For greater battery life, turn off the headphones when they are not in use by pressing the red button again. They will turn off automatically if they do not receive an audio signal from the system for several minutes. When not in use, store the headphones in the pocket on the back of either front seat.

### Replacing Batteries

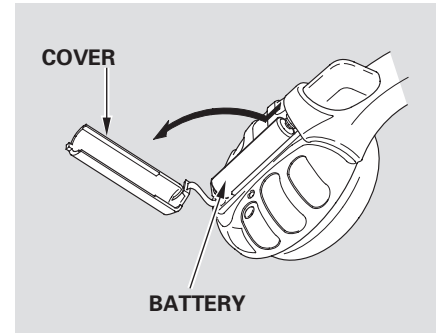

The batteries are under the domed covers on the back of each earpiece. To remove a cover, press down on it with your thumb, slide it backward (away from the haedband), then lift it up. Remove the batteries and note their polarity. Install the new batteries in the earpiece with the same polarity. Set the cover in place, then slide it up until it locks. Each headphone uses two AAA batteries.

# Rear Entertainment System

## Auxiliary Input Jacks

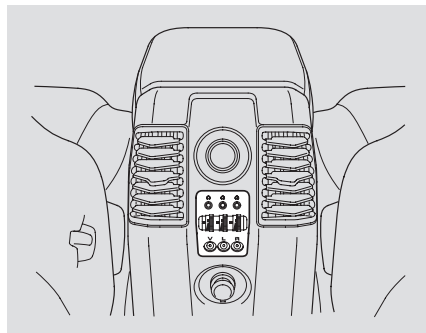

Auxiliary input jacks and headphone connectors for the rear entertainment system are on the back of the center console compartment.

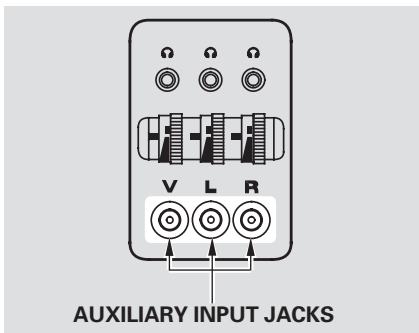

The system will accept auxiliary inputs from standard video games and video equipment.

V = Video jack  
L = Left audio jack  
R = Right audio jack

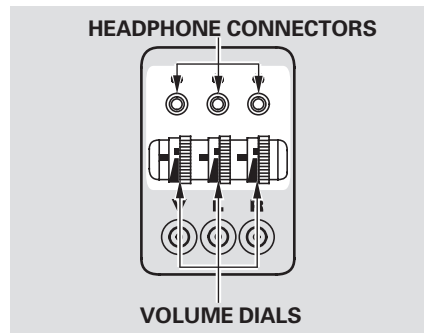

There are three headphone connectors for the third seat passengers. Each connector has its own volume control.

### *On EX models*

The security system helps to protect your vehicle and valuables from theft. The horn sounds and a combination of headlights, parking lights, side marker lights, and taillights flash if someone attempts to break into your vehicle. This alarm continues for two minutes, then the system resets. To reset an alarm system before the two minutes have elapsed, unlock the driver's front door with the key or the remote transmitter.

The security system automatically sets fifteen seconds after you lock the doors, hood, and the tailgate. For the system to activate, you must lock the doors from the outside with the key or remote transmitter. The security system light starts blinking immediately to show you the system is setting itself.

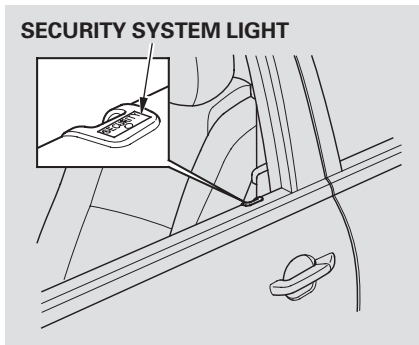

Once the security system is set, opening any door without using the key or the remote transmitter, or the hood, will cause it to alarm. It also alarms if the radio is removed from the dashboard or the wiring is cut.

The security system will not set if the hood, the tailgate, or any door is not fully closed. If the system will not set, check the Door and Tailgate Open Monitor on the instrument panel (see page 50) to see if the doors and the tailgate are fully closed. Since it is not part of the monitor display, manually check the hood.

Do not attempt to alter this system or add other devices to it.

## Cruise Control

Cruise control allows you to maintain a set speed above 25 mph (40 km/h) without keeping your foot on the accelerator pedal. It should be used for cruising on straight, open highways. It is not recommended for city driving, winding roads, slippery roads, heavy rain, or bad weather.

### **⚠ WARNING**

Improper use of the cruise control can lead to a crash.

Use the cruise control only when traveling on open highways in good weather.

### Using the Cruise Control

#### CRUISE CONTROL MASTER SWITCH

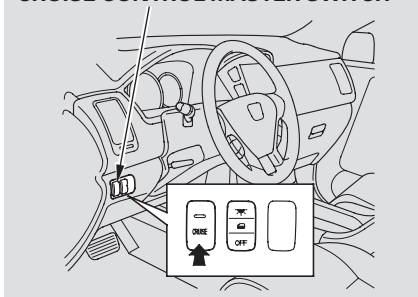

1. Push in the Cruise Control Master Switch. The indicator in the switch will come on.
2. Accelerate to the desired cruising speed above 25 mph (40 km/h).
3. Press and release the SET/DECEL button on the steering wheel. The indicator on the instrument panel comes on to show the system is now activated.

#### RESUME/ACCEL

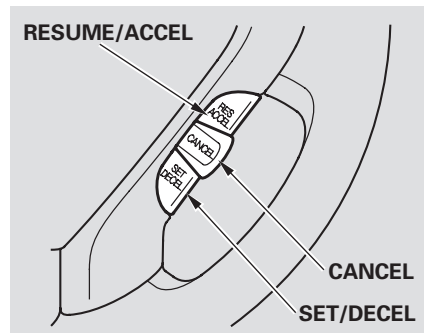

Cruise control may not hold the set speed when you are going up and down hills. If your speed increases going down a hill, use the brakes to slow down. This will cancel the cruise control. To resume the set speed, press the RESUME/ACCEL button. The indicator on the instrument panel will come back on.



### Changing the Set Speed

You can increase the set cruising speed in any of these ways:

- Press and hold the RESUME/ACCEL button. When you reach the desired cruising speed, release the button.
- Push on the accelerator pedal. Accelerate to the desired cruising speed and press the SET/DECEL button.
- To increase your speed in very small amounts, tap the RESUME/ACCEL button. Each time you do this, your vehicle will speed up about 1 mph (1.6 km/h).

You can decrease the set cruising speed in any of these ways:

- Press and hold the SET/DECEL button. Release the button when you reach the desired speed.

- To slow down in very small amounts, tap the SET/DECEL button. Each time you do this, your vehicle will slow down about 1 mph (1.6 km/h).
- Tap the brake pedal lightly with your foot. The CRUISE CONTROL indicator on the instrument panel will go out. When the vehicle slows to the desired speed, press the SET/DECEL button.

Even with the cruise control turned on, you can still use the accelerator pedal to speed up for passing. After completing the pass, take your foot off the accelerator pedal. The vehicle will return to the set cruising speed.

Resting your foot on the brake pedal will cause the cruise control to cancel.

### Cancelling the Cruise Control

You can cancel the cruise control in any of these ways:

- Tap the brake pedal.
- Push the CANCEL button on the steering wheel.
- Press the Cruise Control Master Switch.

### Resuming the Set Speed

When you push the CANCEL button or tap on the brake pedal, the system will remember the previously set cruising speed. To return to that speed, accelerate to above 25 mph (40 km/h) and then press and release the RESUME/ACCEL button. The CRUISE CONTROL light comes on. The vehicle will accelerate to the same cruising speed as before.

Pressing the Cruise Control Master Switch turns the system off and erases the previous cruising speed.

# HomeLink Universal Transceiver

---

## *On EX Models*

The HomeLink® Universal Transceiver built into your vehicle can be programmed to operate up to three remote controlled devices around your home, such as garage doors, lighting, or home security systems.

## **General Information**

If you are training HomeLink to operate a garage door or gate, you should unplug the motor for that device during training. Repeatedly pressing the remote control button could burn out the motor.

The HomeLink Transceiver stores the code in a permanent memory. There should be no need to retrain HomeLink if your vehicle's battery goes dead or is disconnected.

If your garage door opener was manufactured before April 1982, you may not be able to program HomeLink to operate it. They do not have the safety feature that causes

the motor to stop and reverse if an obstacle is detected during closing, increasing the risk of injury.

## **Important Safety Precautions**

Always refer to the opening instructions and safety information that came with your garage door opener or other equipment you intend to operate with the HomeLink Universal Transceiver. If you do not have this information, contact the manufacturer of the equipment.

## **Training HomeLink**

**Before you begin** – If you just received your vehicle and have not trained any of the buttons in HomeLink before, you should erase any previously learned codes before training the first button. To do this, press and hold the two outside buttons on HomeLink Transceiver for about 20 seconds, or until the red light flashes. Release the buttons, then proceed to Step 1.

If you are training the second or third buttons, go directly to Step 1.

1. Unplug the garage door opener motor from the house current.
2. Hold the end of the garage door opener remote control 2 to 5 inches from HomeLink. Make sure you are not blocking your view of the red light in HomeLink.

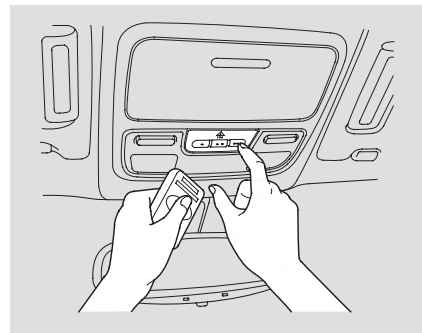

3. Press and hold the remote control button and one of the HomeLink buttons at the same time.

*Canadian Owners:* The remote control you are training from may stop transmitting after two seconds. This is not long enough for HomeLink to learn the code. Release and press the button on the remote control every two seconds until HomeLink has learned the code.

4. The red light in HomeLink should begin flashing. It will flash slowly at first, then rapidly.
5. When the red light flashes rapidly, release both buttons. HomeLink should have learned the code from the remote control.

6. Plug in the garage door opener motor, then test the HomeLink Transceiver button by pushing it. If the button does not work, repeat the procedure to train it again. If it still does not work, you may have a variable or rolling code garage door opener. See if you do by pressing and holding the HomeLink transceiver button you just trained. If the red light blinks for two seconds, then stays on, you have a rolling code garage door opener. Go to “Training With a Rolling Code System” (see page 120).
7. Repeat these steps to train the other two HomeLink buttons to operate any other remotely-controlled devices around your home (lighting, automatic gate, security system, etc.).

# HomeLink Universal Transceiver

## Training With a Rolling Code System

For security purposes, newer garage door opening systems use a “rolling” or variable code. Information from the remote control and the garage door opener are needed before HomeLink can operate the garage door opener.

The “Training HomeLink” procedure trains HomeLink to the proper garage door opener code. The following procedure synchronizes HomeLink to the garage door opener so they send and receive the correct codes.

1. Make sure you have properly completed the “Training HomeLink” procedure.
2. Find the “Training” button on your garage door opener unit. The location will vary, depending on the manufacturer.

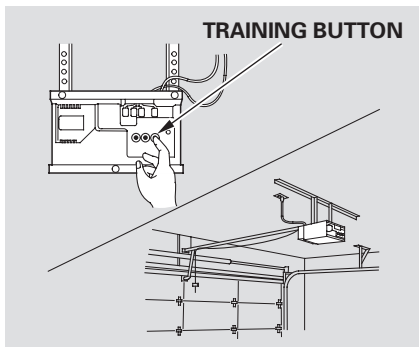

3. Press the Training button on the garage door opener unit until the light next to the button comes on, then release it. The light may blink, or come on and stay on. You then have approximately 30 seconds to complete the following steps.
4. Press and hold the button on HomeLink for 3 – 4 seconds.
5. Press and hold the HomeLink button again for 3 – 4 seconds.

This should turn off the training light on the garage door opener unit. (Some systems may require you to press the button up to three times.)

6. Press the HomeLink button again. It should operate the garage door.

## Erasing Codes

To erase the codes stored in all three buttons, press and hold the two outside buttons until the red light begins to flash, then release the buttons.

You should erase all three codes before selling the vehicle.

## Retraining a Button

To train an already programmed transceiver button with a new device, you do not have to erase all the memory. Train the selected button over the existing memory code following the steps under **Training HomeLink**.

## Customer Assistance

If you have problems with training the HomeLink Universal Transceiver, or would like information on home products that can be operated by the transmitter, call (800) 355-3515. On the Internet, go to [www.homelink.com](http://www.homelink.com).

*As required by the FCC:*

*This device complies with Part 15 of the FCC rules. Operation is subject to the following two conditions: (1) This device may not cause harmful interference, and (2) this device must accept any interference received, including interference that may cause undesired operation.*

*Changes or modifications not expressly approved by the party responsible for compliance could void the user's authority to operate the equipment.*

*This device complies with Industry Canada Standard RSS-210. Operation is subject to the following two conditions: (1) this device may not cause interference, and (2) this device must accept any interference that may cause undesired operation of the device.*



Before you begin driving your Honda, you should know what gasoline to use, and how to check the levels of important fluids. You also need to know how to properly store luggage or packages. The information in this section will help you. If you plan to add any accessories to your vehicle, please read the information in this section first.

Break-in Period .....	124
Fuel Recommendation .....	124
Service Station Procedures .....	125
Fuel Economy .....	128
Accessories and Modifications ....	129
Carrying Cargo .....	131

## Break-in Period, Fuel Recommendation

---

### Break-in Period

Help assure your vehicle's future reliability and performance by paying extra attention to how you drive during the first 600 miles (1,000 km). During this period:

- Avoid full-throttle starts and rapid acceleration.
- Do not change the oil until the scheduled maintenance time.
- Avoid hard braking for the first 200 miles (300 km).
- Do not tow a trailer.

You should also follow these recommendations with an overhauled or exchanged engine, or when the brakes are replaced.

### Fuel Recommendation

Your Honda is designed to operate on unleaded gasoline with a pump octane number of 86 or higher. Use of a lower octane gasoline can cause occasional metallic knocking noises in the engine and will result in decreased engine performance.

We recommend using gasoline containing detergent additives that help prevent fuel system and engine deposits.

In addition, in order to maintain good performance, fuel economy, and emissions control, we strongly recommend, in areas where it is available, the use of gasoline that does NOT contain manganese-based fuel additives such as MMT.

Use of gasoline with these additives may adversely affect performance, and cause the Malfunction Indicator Lamp on your instrument panel to

come on. If this happens, contact your authorized Honda dealer for service.

For further important fuel-related information, please refer to your **Quick Start Guide**.

Some gasoline today is blended with oxygenates such as ethanol or MTBE. Your vehicle is designed to operate on oxygenated gasoline containing up to 10 percent ethanol by volume and up to 15 percent MTBE by volume. Do not use gasoline containing methanol.

If you notice any undesirable operating symptoms, try another service station or switch to another brand of gasoline.

Premium fuel is recommended when towing in certain conditions (see page [152](#) ).



### Refueling

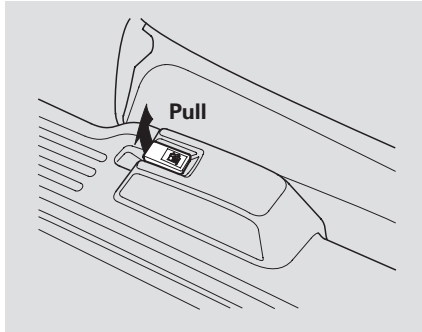

1. Park with the driver's side closest to the gas pump.
2. Open the fuel fill door by pulling on the handle to the left of the driver's seat.
3. Remove the fuel fill cap slowly. You may hear a hissing sound as pressure inside the tank escapes. Place the cap in the holder on the fuel fill door.

### **⚠ WARNING**

Gasoline is highly flammable and explosive. You can be burned or seriously injured when handling fuel.

- Stop the engine and keep heat, sparks, and flames away.
- Handle fuel only outdoors.
- Wipe up spills immediately.

4. Stop filling the tank after the fuel nozzle automatically clicks off. Do not try to "top off" the tank. Leave some room for the fuel to expand with temperature changes.

*If the fuel nozzle keeps clicking off even though the tank is not full, there may be a problem with your vehicle's fuel vapor recovery system. The system helps keep fuel vapors from going into the atmosphere. Consult your dealer.*

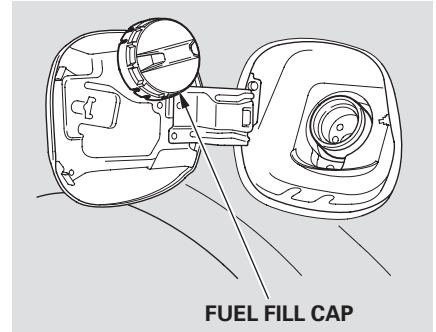

**FUEL FILL CAP**

5. Screw the fuel fill cap back on until it clicks at least three times. If you do not properly tighten the cap, the Malfunction Indicator Lamp may come on (see page [207](#)).
6. Push the fuel fill door closed until it latches.

# Service Station Procedures

## Opening the Hood



1. Park the vehicle, and set the parking brake. Pull the hood release handle located under the lower left corner of the dashboard. The hood will pop up slightly.
2. Put your fingers under the front edge of the hood to the left of the center. Slide your hand to the left until you feel the hood latch handle. Push this handle up to release it. Lift up the hood.

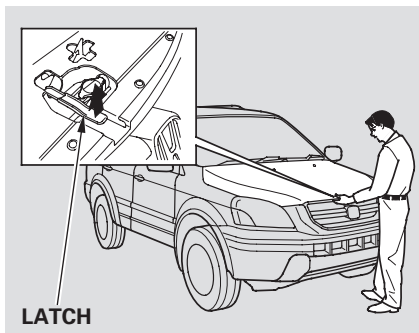

- If the hood latch handle moves stiffly, or if you can open the hood without lifting the handle, the mechanism should be cleaned and lubricated.
3. Pull the support rod out of its clip, and insert the end into the hole at the center of the hood or the hole on the left side of the hood.

## To Close the Hood

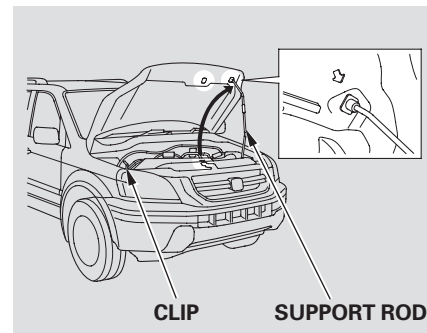

Lift it up slightly to remove the support rod from the hole. Put the support rod back into its holding clip. Lower the hood to about a foot (30 cm) above the fender, then let it drop. Make sure it is securely latched.

### Oil Check

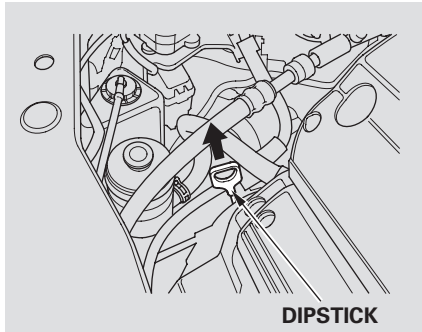

Wait a few minutes after turning the engine off before you check the oil.

1. Remove the dipstick (orange handle).
2. Wipe off the dipstick with a clean cloth or paper towel.
3. Insert it all the way back into its tube.

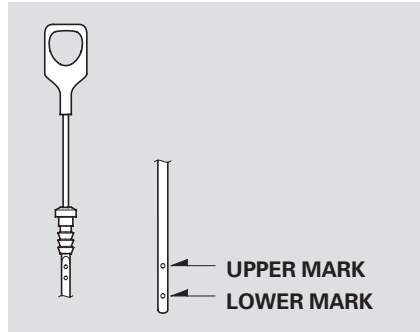

4. Remove the dipstick again and check the level. It should be between the upper and lower marks.

If it is near or below the lower mark, see **Adding Oil** on page 171.

### Engine Coolant Check

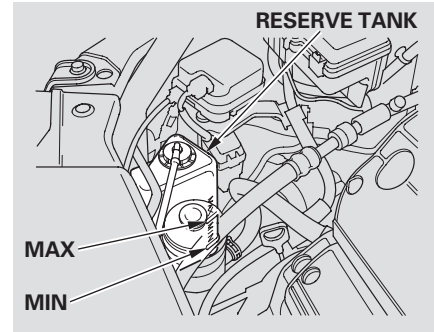

Look at the coolant level in the radiator reserve tank. Make sure it is between the MAX and MIN lines. If it is below the MIN line, see **Adding Engine Coolant** on page 174 for information on adding the proper coolant.

Refer to **Owner's Maintenance Checks** on page 163 for information on checking other items in your Honda.

## Fuel Economy

---

### Improving Fuel Economy

- Always maintain your vehicle according to the maintenance schedule. See **Owner's Maintenance Checks** (see page [163](#)).

*For example*, an underinflated tire causes more “rolling resistance,” which uses fuel.

The build-up of snow or mud on your vehicle's underside adds weight and rolling resistance. Frequent cleaning helps your fuel mileage and reduces the chance of corrosion.

- Drive moderately. Rapid acceleration, abrupt cornering and hard braking use more fuel.
- Always drive in the highest gear possible.

- Try to maintain a constant speed. Every time you slow down and speed up, your vehicle uses extra fuel. Use the cruise control when appropriate.
- Combine several short trips into one.
- The air conditioning puts an extra load on the engine which makes it use more fuel. Use the fresh-air ventilation when possible.

Modifying your vehicle, or installing some non-Honda accessories, can make your vehicle unsafe. Before you make any modifications or add any accessories, be sure to read the following information.

### Accessories

Your dealer has Honda accessories that allow you to personalize your vehicle. These accessories have been designed and approved for your vehicle, and are covered by warranty.

Although aftermarket accessories may fit on your vehicle, they may not meet factory specifications, and could adversely affect your vehicle's handling and stability. (See "Modifications" on page 130 for additional information.)

### **WARNING**

Improper accessories or modifications can affect your vehicle's handling, stability, and performance, and cause a crash in which you can be hurt or killed.

Follow all instructions in this owner's manual regarding accessories and modifications.

When properly installed, cellular phones, alarms, two-way radios, and low-powered audio systems should not interfere with your vehicle's computer controlled systems, such as the SRS and anti-lock brake system.

Before installing any accessory:

- Make sure the accessory does not obscure any lights, or interfere with proper vehicle operation or performance.
- Be sure electronic accessories do not overload electrical circuits (see page 212) or interfere with proper operation.
- Have the installer contact your Honda dealer for assistance before installing any electronic accessory.

## Accessories and Modifications

---

### Modifying Your Vehicle

Removing parts from your vehicle, or replacing components with non-Honda (aftermarket) components could seriously affect your vehicle's handling, stability, and reliability.

Some examples are:

- Lowering your vehicle with an aftermarket suspension kit that significantly reduces ground clearance can allow the undercarriage to hit speed bumps or other raised objects, which could cause the airbags to deploy.
- Raising your vehicle with an aftermarket suspension kit can affect the handling and stability.
- Aftermarket wheels, because they are a universal design, can cause excessive stress on suspension components.

- Larger or smaller wheels and tires can interfere with the operation of your vehicle's anti-lock brakes and other systems.

Do not modify your steering wheel or any other part of your Supplemental Restraint System. Modifications could make the system ineffective.

If you plan to modify your vehicle, consult your Honda dealer.

### Additional Safety Precautions

- **Do not attach or place objects on the airbag covers.** Any object attached to or placed on the covers marked "SRS AIRBAG" in the center of the steering wheel and on top the dashboard, and front seat back could interfere with the proper operation of the airbags. Or, if the airbags inflate, the objects could be propelled inside the vehicle and hurt someone.
- **Do not attach hard objects on or near a front door.** If a side airbag inflates, a cup holder or other hard object attached on or near the door could be propelled inside the vehicle and hurt someone.
- **Do not place any objects over or replace the outside edge of a front seat-back.** This could prevent the airbag from inflating properly.

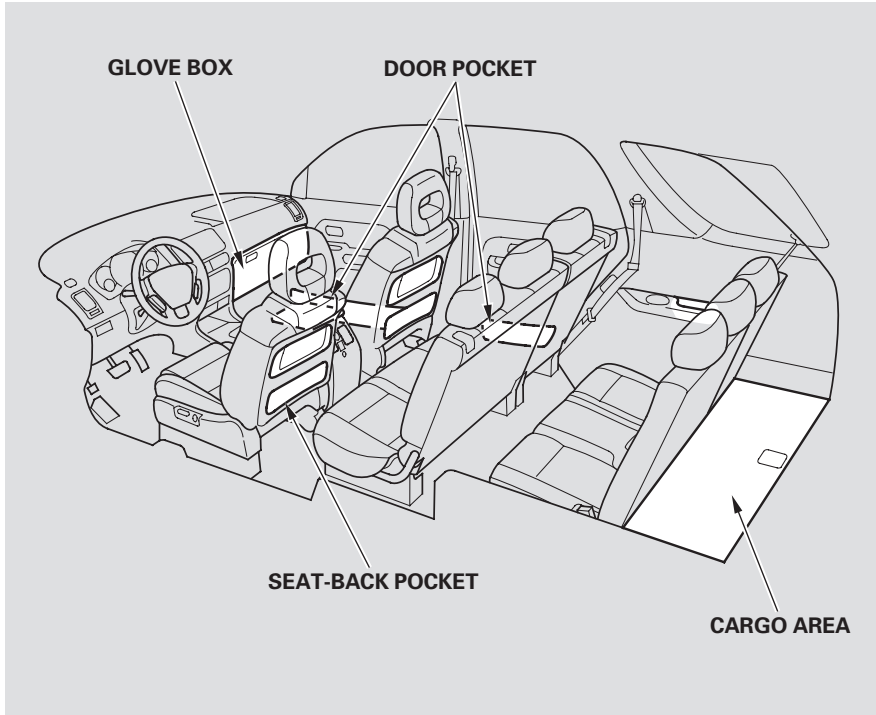

Your vehicle has several convenient storage areas:

- Glove box
- Door and seat-back pockets
- Rear cargo area, including the second and third row seats when folded flat
- Roof-rack (if installed)

However, carrying too much cargo, or improperly storing it, can affect your vehicle's handling, stability, stopping distance, and tires, and make it unsafe. Before carrying any type of cargo, be sure to read the following pages.

### **⚠ WARNING**

Overloading or improper loading can affect handling and stability and cause a crash in which you can be hurt or killed.

Follow all load limits and other loading guidelines in this manual.

## Carrying Cargo

---

The maximum load for your vehicle is 1,323 lbs (600 kg). This figure includes the total weight of all occupants, cargo, accessories, and the tongue weight if you are towing a trailer.

To determine the correct cargo and luggage load limit:

1. Locate the statement, “the combined weight of occupants and cargo should never exceed 1,323 lbs (600 kg)” on your vehicle’s placard (on the driver’s doorjamb).
2. Determine the combined weight of the driver and passengers that will be riding in the vehicle. (Eight is seating capacity of your vehicle.)
3. Subtract the combined weight of the driver and passengers from 1,323 lbs (600 kg).

4. The resulting figure equals the available amount of cargo and luggage load capacity.

For example, if there will be five 150 lbs (70 kg) occupants in your vehicle, the amount of available cargo and luggage load capacity is 573 lbs (250 kg).

$$5 \times 150 \text{ lbs (70 kg)} = 750 \text{ lbs (350 kg)}$$

$$1,323 \text{ lbs (600 kg)} - 750 \text{ lbs (350 kg)} = 573 \text{ lbs (250 kg)}$$

5. Determine the combined weight of accessories, luggage, and cargo being loaded in the vehicle. The weight may not safely exceed the available cargo and luggage load capacity calculated in step 4 [573 lbs (250 kg) in this example].

6. If your vehicle will be towing a trailer, the load from your trailer will be transferred to your vehicle. Consult this manual to determine how this reduces the available cargo and luggage load capacity of your vehicle.

The total weight must not exceed the Gross Vehicle Weight Rating (GVWR). The load for the front and rear axles also must not exceed the Gross Axle Weight Rating (GAWR) (see page 148).

### Optional Separation Net

The separation net can be used to hold back soft lightweight items stored in the cargo area. Heavy items should be properly secured on the floor of the cargo area.



### Carrying Cargo in the Cargo Area or on a Roof Rack

- Distribute cargo evenly on the floor of the cargo area, placing the heaviest items on the bottom and as far forward as possible. Tie down items that could be thrown about the vehicle during a crash or sudden stop.
- If you carry large items that prevent you from closing the tailgate, exhaust gas can enter the passenger area. To avoid the possibility of **carbon monoxide poisoning**, follow the instructions on page 42 .
- If you carry any items on a roof rack, be sure the total weight of the rack and the items does not exceed 165 lbs (75 kg).

If you use an accessory roof rack, the roof rack weight limit may be lower. Refer to the information that

came with your roof rack.

### Carrying Items in the Passenger Compartment

- Store or secure all items that could be thrown around and hurt someone during a crash.
- Be sure items placed on the floor behind the front seats cannot roll under the seats and interfere with the pedals or seat operation.
- Keep the glove box closed while driving. If it is open, a passenger could injure their knees during a crash or sudden stop.

### Optional Cargo Cover

The cargo cover can be used over the cargo area behind the third row seats. When the third row seats are folded down, the cargo cover can be installed in a forward position and extended over the larger cargo area.

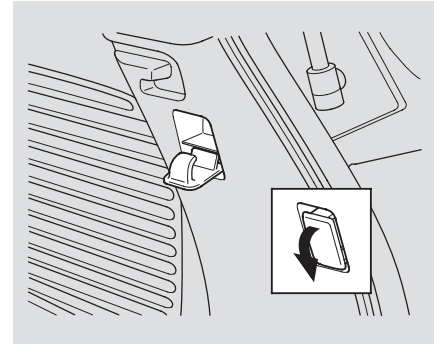

The hooks on each side of the tailgate and on the underside of the cargo area storage compartment lid are for plastic grocery bags. To use the hook on the storage compartment lid, open the lid, and attach the cord to one of the shafts of the third seat center head restraint.

*On LX model* — The hook on the rear of the console compartment is for plastic grocery bags.



This section gives you tips on starting the engine under various conditions, and how to operate the automatic transmission. It also includes important information on parking your vehicle, the braking system, the VTM-4 System, and facts you need if you are planning to tow a trailer.

Driving Guidelines.....	136
Starting the Engine.....	137
Automatic Transmission.....	138
VTM-4 System .....	142
Parking Tips .....	143
Braking System.....	144
Anti-lock Brakes (ABS) .....	145
Towing a Trailer .....	147
Trailer Driving Tips.....	152
Towing Your Vehicle Behind a Motorhome.....	154
Off-Highway Driving Guidelines.....	155

## Driving Guidelines

---

Your vehicle has a higher ground clearance that allows you to travel over bumps, obstacles, and rough terrain. It also provides good visibility so you can anticipate problems earlier.

Because your vehicle rides higher off the ground, it has a high center of gravity that can cause it to roll over if you make abrupt turns. Utility vehicles have a significantly higher roll over rate than other types of vehicles.

To prevent rollovers or loss of control:

- Take corners at slower speeds than you would with a passenger vehicle.
- Avoid sharp turns and abrupt maneuvers whenever possible.

- Do not modify your vehicle in any way that would raise the center of gravity.
- Do not carry heavy cargo on the roof.

*See page 155 for additional driving off-highway guidelines.*

### Preparing to Drive

You should do the following checks and adjustments before you drive your vehicle.

1. Make sure all windows, mirrors, and outside lights are clean and unobstructed. Remove frost, snow, or ice.
2. Visually check the tires. If a tire looks low, use a gauge to check its pressure.

3. Check that any items you may be carrying are stored properly or fastened down securely.
4. Check the seat adjustment (see page 68 ).
5. Check the adjustment of the inside and outside mirrors (see page 74 ).
6. Check the steering wheel adjustment (see page 61 ).
7. Make sure the doors and the tailgate are securely closed and locked.
8. Fasten your seat belt. Check that your passengers have fastened their seat belts (see page 12 ).
9. When you start the engine, check the gauges and indicator lights in the instrument panel (see page 47 ).

1. Apply the parking brake.
2. In cold weather, turn off all electrical accessories to reduce the drain on the battery.
3. Make sure the shift lever is in Park. Press on the brake pedal.
4. Without touching the accelerator pedal, turn the ignition key to the START (III) position. Do not hold the key in START for more than 15 seconds at a time. If the engine does not start right away, pause for at least 10 seconds before trying again.
5. If the engine does not start within 15 seconds, or starts but stalls right away, repeat step 4 with the accelerator pedal pressed halfway down. If the engine starts, release pressure on the accelerator pedal so the engine does not race.
6. If the engine fails to start, press the accelerator pedal all the way down and hold it there while starting to clear flooding. If the engine still does not start, return to step 5.

**NOTICE:** *The engine is harder to start in cold weather. Also, the thinner air found at altitudes above 8,000 feet (2,400 meters) adds to this problem.*

# Automatic Transmission

## Shift Lever Position Indicators

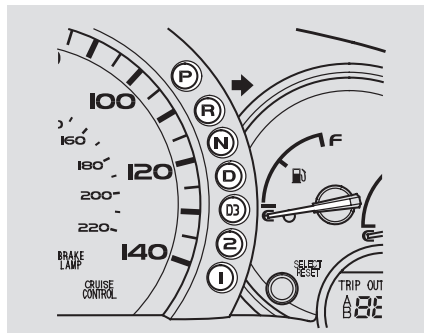

These indicators on the instrument panel show which position the shift lever is in.

The “D” indicator comes on for a few seconds when you turn the ignition switch to ON (II). If it flashes while driving (in any shift position), it indicates a possible problem in the transmission.

If the malfunction indicator lamp comes on along with the “D” indicator, there is a problem in the automatic transmission control system. Avoid rapid acceleration and have the transmission checked by a Honda dealer as soon as possible.

## Shifting

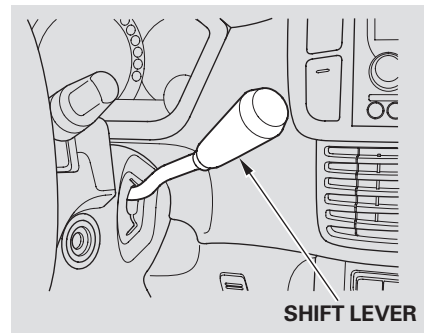

To shift from any position, pull the lever toward you. You cannot shift out of Park when the ignition switch is in the LOCK (0) or ACCESSORY (I) positions.

## Automatic Transmission

To shift from:	Do this:
P to R	Press the brake pedal and pull the shift lever towards you.
R to P N to R D <sub>3</sub> to 2 2 to 1	Pull the shift lever towards you.
1 to 2 2 to D <sub>3</sub> D <sub>3</sub> to D D to N D to D <sub>3</sub> N to D R to N	Move the lever.

**Park (P)** – This position mechanically locks the transmission. Use Park whenever you are turning off or starting the engine. To shift out of Park, you must press on the brake pedal and have your foot off the accelerator pedal.

If you have done all of the above and still cannot move the lever out of Park, see **Shift Lock Release** on page 141.

To avoid transmission damage, come to a complete stop before shifting into Park. The shift lever must be in Park before you can remove the key from the ignition switch.

**Reverse (R)** – Press the brake pedal and pull the shift lever towards you to shift from Park to Reverse. To shift from Reverse to Natural, come to a complete stop and then shift.

**Neutral (N)** – Use Neutral if you need to restart a stalled engine, or if it is necessary to stop briefly with the engine idling. Shift to the Park position if you need to leave your vehicle for any reason. Press on the brake pedal when you are moving the shift lever from Neutral to another gear.

**Drive (D)** – Use this position for your normal driving. The transmission automatically selects a suitable gear for your speed and acceleration. You may notice the transmission shifting up at higher speeds when the engine is cold. This helps the engine warm up faster.

*CONTINUED*

## Automatic Transmission

---

**Drive (D3)** – This position is similar to D, except only the first three gears are selected. Use D3 when towing a trailer in hilly terrain, or to provide engine braking when going down a steep hill. D3 can also keep the transmission from cycling between third and fourth gear in stop-and-go driving.

**Second (2)** – This position locks the transmission in second gear. It does not downshift to first gear when you come to a stop.

Use Second gear:

- For more power when climbing.
- To increase engine braking when going down steep hills.
- For starting out on a slippery surface or in deep snow.
- To help reduce wheel spin.

- When driving downhill with a trailer.

**First (1)** – This position locks, the transmission locks in first gear. By upshifting and downshifting through 1, 2, D3, and D, you can operate the transmission much like a manual transmission without a clutch pedal.

### Engine Speed Limiter

If you exceed the maximum speed for the gear you are in, the engine speed will enter into the tachometer's red zone. If this occurs, you may feel the engine cut in and out. This is caused by a limiter in the engine's computer controls. The engine will run normally when you reduce the RPM below the red zone.



### Shift Lock Release

Do this if pushing on the brake pedal and pulling the shift lever does not shift the transmission out of Park:

1. Set the Parking brake.
2. Make sure the key is in the ignition switch LOCK (0) position.

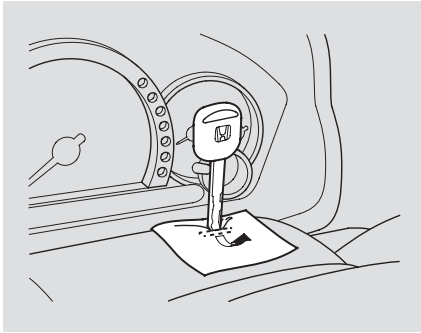

3. Put a cloth on the edge of the Shift Lock Release slot cover. Using a key, carefully pry on the edge of the cover to remove it.

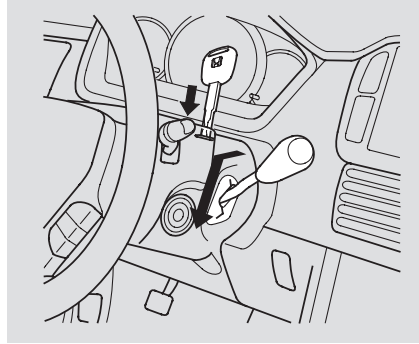

4. Insert the key in the Shift Lock Release slot.
5. Push down on the key while you pull the shift lever towards you and move it out of Park to Neutral.
6. Remove the key from the Shift Lock Release slot, then install the cover. Press the brake pedal, and restart the engine.

If you need to use the Shift Lock Release, it means your vehicle is developing a problem. Have it checked by a Honda dealer.

## VTM-4 System

---

The Variable Torque Management 4WD System (VTM-4) automatically transfers varying amounts of engine torque to the rear wheels under lower traction conditions.

If more traction is needed when your vehicle is stuck, or is likely to become stuck, you can use the VTM-4 Lock button to increase torque to the rear wheels.

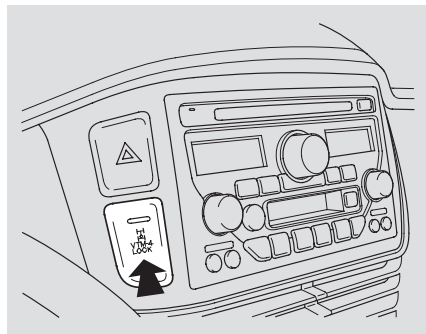

### To Engage the VTM-4 Lock

1. The vehicle must be stopped with the engine running.
2. Move the shift lever to First (1), Second (2), or Reverse (R) gear.
3. Press the VTM-4 Lock button. The light in the button will come on.

To get unstuck, apply light pressure to the accelerator pedal. Do not spin the front tires for more than a few seconds. Because of the amount of torque applied to the rear tires, they should not spin. This is normal. If you are not able to move the vehicle, stop and reverse direction.

**NOTICE:** Do not use the VTM-4 Lock button on dry, paved roads. Driving on dry, paved roads with VTM-4 Lock ON may damage the rear differential when making a turn. Strange noise and vibration can also result.

**To Disengage the VTM-4 Lock**, do one of the following:

- Press the VTM-4 Lock button.
- Move the shift lever to D or D3.
- Turn the ignition to LOCK (0).

The VTM-4 Lock will temporarily disengage when the vehicle speed exceeds 18 mph (30 km/h). It will automatically engage again as the speed slows below 18 mph (30 km/h). The button light will remain on.

**NOTICE:** Do not continually spin the front tires of your vehicle. Continuously spinning the front tires can cause transmission or rear differential damage.

Always use the parking brake when you park your vehicle. Make sure the parking brake is set firmly or your vehicle may roll if it is on an incline.

Set the parking brake before you put the transmission in Park. This keeps the vehicle from moving and putting pressure on the parking mechanism in the transmission.

### **Parking Tips**

- Make sure the windows are closed.
  - Turn off the lights.
  - Place any packages, valuables, etc. in the cargo area, or take them with you.
  - Lock the doors.
  - Never park over dry leaves, tall grass, or other flammable materials. The hot three way catalytic converter could cause these materials to catch on fire.
  - If the vehicle is facing uphill, turn the front wheels away from the curb.
  - If the vehicle is facing downhill, turn the front wheels toward the curb.
- Make sure the parking brake is fully released before driving away. Driving with the parking brake partially set can overheat or damage the rear brakes.

## Braking System

### Braking System

Your Honda is equipped with disc brakes on all four wheels. A power assist helps reduce the effort needed on the brake pedal. The ABS helps you retain steering control when braking very hard.

Resting your foot on the pedal keeps the brakes applied lightly, builds up heat, and reduces their effectiveness. It also keeps your brake lights on all the time, confusing drivers behind you.

Constant application of the brakes when going down a long hill builds up heat and reduces their effectiveness. Use the engine to assist the brakes by taking your foot off the accelerator and downshifting to a lower gear.

Check the brakes after driving through deep water. Apply the brakes moderately to see if they feel normal. If not, apply them gently and frequently until they do. Be extra cautious in your driving.

### Braking System Design

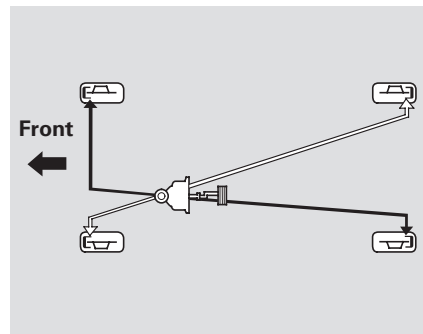

The hydraulic system that operates the brakes has two separate circuits. Each circuit works diagonally across the vehicle (the left-front brake is connected with the right-rear brake, etc.). If one circuit should develop a problem, you will still have braking at two wheels.

## Braking System, Anti-lock Brakes (ABS)

### Brake Wear Indicators

If the brake pads need replacing, you will hear a distinctive, metallic screeching sound when you apply the brake pedal. If you do not have the brake pads replaced, they will screech all the time. It is normal for the brakes to occasionally squeal or squeak when you apply them.

### Anti-lock Brakes (ABS)

The Anti-lock Brake System (ABS) helps prevent the brakes from locking up and helps you retain steering control by pumping the brakes rapidly, much faster than a person can do it.

The ABS also balances the front-to-rear braking distribution according to vehicle loading.

*You should never pump the brake pedal; this defeats the purpose of the ABS.*

Let the ABS work for you by always keeping firm, steady pressure on the brake pedal as you steer away from the hazard. This is sometimes referred to as “stomp and steer.”

### Activating the Anti-lock Brakes

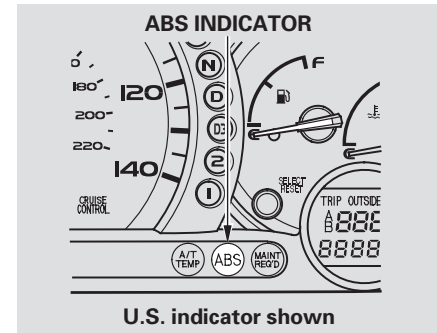

You will feel a pulsation in the brake pedal when the ABS activates, and you may hear some noise. This is normal: it is the ABS rapidly pumping the brakes. On dry pavement, you will need to press on the brake pedal very hard before the ABS activates. However, you may feel the ABS activate immediately if you are trying to stop on snow or ice.

## Anti-lock Brakes (ABS)

---

### ABS Indicator

If the ABS indicator comes on, the anti-lock function of the braking system has shut down. The brakes still work like a conventional system, but without anti-lock. You should have the dealer inspect your vehicle as soon as possible.

If the ABS indicator and the brake system indicator come on together, and the parking brake is fully released, the front-to-rear braking distribution system may also be shut down.

Test your brakes as instructed on page 208. If the brakes feel normal, drive slowly and have your vehicle repaired by your Honda dealer as soon as possible. Avoid sudden hard braking which could cause the rear wheels to lock up and possibly lead to a loss of control.

### *Important Safety Reminders*

**ABS does not reduce the time or distance it takes to stop the vehicle.** It only helps with the steering control during braking.

**ABS will not prevent a skid that results from changing direction abruptly,** such as trying to take a corner too fast or making a sudden lane change. Always drive at a safe speed for the road and weather conditions.

**ABS cannot prevent a loss of stability.** Always steer moderately when you are braking hard. Severe or sharp steering wheel movement can still cause your vehicle to veer into oncoming traffic or off the road.

**A vehicle with ABS may require a longer distance to stop** on loose or uneven surfaces, such as gravel or snow, than a vehicle without anti-lock. Slow down and allow a greater distance between vehicles under those conditions.

To safely tow a trailer, you should observe the load limits, use the proper equipment, and follow the guidelines in this section.

Be sure to read the *Driving Off-Highway Guidelines* section on page [155](#) if you plan to tow off paved surfaces.

### **WARNING**

Exceeding any load limit or improperly loading your vehicle and trailer can cause a crash in which you can be seriously hurt or killed.

Check the loading of your vehicle and trailer carefully before starting to drive.

### **Load Limits**

The total trailer weight and tongue load vary depending on the number of occupants in your vehicle and the type of trailer being towed.

### **Total Trailer Weight**

See page [150](#) for limits for your towing situation. Towing a load that is too heavy can seriously affect your vehicle's handling and performance.

### **Tongue Load**

The weight that the tongue of a fully loaded trailer puts on the hitch should be 5 to 10 percent of the total trailer weight for boat trailers, and 8 to 15 percent of total trailer weight for all other trailers. See page [150](#) for limits for your towing situation.

Too much tongue load reduces front-tire traction and steering control. Too little tongue load can make the trailer unstable and cause it to sway.

*CONTINUED*

## Towing a Trailer

---

### **Gross Vehicle Weight Rating**

**(GVWR)** – The maximum allowable weight of the vehicle, all occupants, all cargo and the tongue load is 5,950 lbs (2,700 kg).

### **Gross Axle Weight Ratings**

**(GAWR)** – The maximum allowable weight on the vehicle axles are 2,865 lbs (1,300 kg) on the front axle, and 3,155 lbs (1,430 kg) on the rear axle.

### **Gross Combined Weight Rating**

**(GCWR)** – The maximum allowable weight of the fully loaded vehicle and trailer is 9,700 lbs (4,410 kg) with the proper hitch and fluid coolers (see page [151](#)).

The GCWR must be reduced 2 percent for every 1,000 feet (305 meters) of elevation.

### **Estimating Loads**

The best way to confirm that all loads are within limits is to check them at a public scale.

To help ensure a safe drive to a scale, or if you cannot get to a public scale, we recommend that you estimate your total trailer weight and tongue load as described next.

### ***To Estimate the Total Trailer Weight***

Add the weight of your trailer (as quoted by the manufacturer) with everything in or on the trailer. Check the tables on page [150](#) that you do not exceed the limit for your conditions.



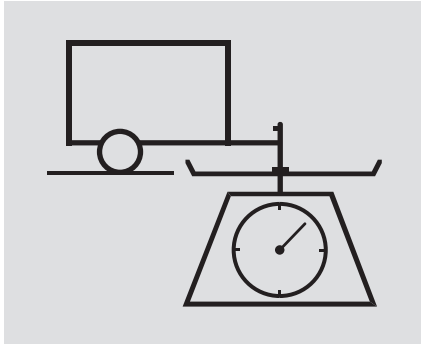

### ***To Estimate the Tongue Load***

1. Park the vehicle on level ground.
2. Measure and record the distance from the ground to the bottom of the trailer hitch.
3. Connect the fully loaded trailer to the hitch.
4. Measure again from the ground to the same spot on the bottom of the hitch.

5. Subtract the second measurement from the first measurement. Refer to Fig. 1.

***Fig. 1***

If the difference is:

- 1" = 150 lbs (68 kg)
- 1 ¾" = 250 lbs (114 kg)
- 2 ½" = 350 lbs (160 kg)
- 3" = 450 lbs (205 kg)
- 3 ¼" = over 450 lbs (205 kg)

If the difference is more than 3 ¼" you have too much tongue load at the rear. Move or remove cargo from the trailer and the vehicle and measure again.

If the estimated trailer weight and tongue load do not exceed the limits, drive your trailer to a public scale fully loaded with all occupants and cargo you plan to take on the road.

### **Trailer Lights**

If your trailer lights burn out, check to see if there are any blown fuses (see page [211](#)).

*CONTINUED*

# Towing a Trailer

---

## Total Trailer Weight and Tongue Load Limits:

### BOAT TRAILERS

Number of Occupants	Equipped with transmission cooler and power steering fluid cooler.	
	Max. Trailer Weight	Max. Tongue Load
2	4,500 lbs (2,045 kg)	450 lbs (205 kg)
3	4,500 lbs (2,045 kg)	450 lbs (205 kg)
4	4,500 lbs (2,045 kg)	450 lbs (205 kg)
5	4,300 lbs (1,945 kg)	350 lbs (160 kg)
6	4,100 lbs (1,855 kg)	220 lbs (100 kg)
7	2,000 lbs (905 kg)	100 lbs (45 kg)
8	Towing is Not Recommended	

### OTHER TYPES OF TRAILERS

Number of Occupants	Equipped with transmission cooler and power steering fluid cooler.	
	Max. Trailer Weight	Max. Tongue Load
2	3,500 lbs (1,590 kg)	450 lbs (205 kg)
3	3,500 lbs (1,590 kg)	450 lbs (205 kg)
4	3,300 lbs (1,490 kg)	450 lbs (205 kg)
5	3,100 lbs (1,400 kg)	350 lbs (160 kg)
6	2,700 lbs (1,220 kg)	220 lbs (100 kg)
7	1,200 lbs (540 kg)	100 lbs (45 kg)
8	Towing is Not Recommended	

The corresponding weight limits assume occupants fill seats from the front of the vehicle to the back, each occupant weighs 150 lbs (70 kg) and each has 15 lbs (7 kg) of luggage in the cargo area.

### **Towing Equipment and Accessories**

Towing generally requires a variety of supplemental equipment. To ensure the best quality, we recommend that you purchase Honda equipment whenever possible.

Discuss any additional needs with your trailer sales or rental agency, and make sure all equipment is properly installed, maintained, and also meets state regulations.

### ***Hitch***

We strongly recommend that you have your Honda dealer install a Honda hitch and use the required fluid coolers. Using non-Honda equipment may result in serious damage to your vehicle.

### ***Weight Distributing Hitch***

A weight distributing hitch is not recommended for use with your Pilot.

### ***Trailer Brakes***

Honda requires that any trailer with a total trailer weight of 1,000 lbs (455 kg) or more have its own brakes.

There are two common types of trailer brakes: surge and electric. Surge brakes are common for boat trailers, since the brakes will get wet.

Electric brakes must be electronically actuated. Do not attempt to tap into your vehicle's hydraulic system. See your brake manufacturer for more information on installing electric brakes.

### ***Safety Chains***

Always use safety chains when you tow a trailer. Make sure the chains are secured to the trailer and hitch, and that they cross under the tongue and can catch the trailer if it becomes unhitched. Leave enough slack to allow the trailer to turn corners easily, but do not let the

chains drag on the ground.

### ***Transmission Fluid Cooler and Power Steering Fluid Cooler***

To help prevent overheating, a heavy-duty transmission fluid cooler and a heavy-duty power steering fluid cooler are required for trailer towing. These coolers are available only from your Honda dealer.

### ***Sway Control***

This device is recommended if your trailer tends to sway. Your trailer maker can tell you what kind of sway control you need and how to install it.

### ***Trailer Mirrors***

Many states and provinces require special exterior mirrors when towing a trailer. Even if they don't, you should install special mirrors if you cannot clearly see behind you, or if the trailer creates a blind spot.

*CONTINUED*

## Towing a Trailer, Trailer Driving Tips

### Trailer Lights

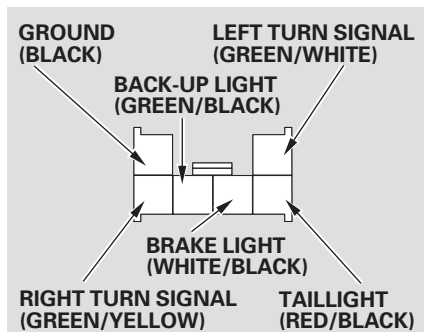

Check trailer light requirements for the areas where you plan to tow.

To get to your vehicle's trailer lighting connector, open the tailgate, remove the cargo cover, then remove the rear panel trim. The connector is on the left side. We recommend that you have your Honda dealer install a Honda wiring harness and converter.

If you use a non-Honda trailer lighting harness and converter, you can get the mating connector and pins that mate with the connector in your vehicle from your Honda dealer.

Connector-98530-00006-00  
Terminal Kit-07JAZ-001-030A

### Spare Tires

When towing a trailer, we recommend that you carry a full-size spare wheel and tire for your vehicle and trailer. See page 191 for proper tire size, page 200 for how to store a full size wheel and tire, and page 197 for information on changing a flat tire.

Remember to unhitch the trailer before changing a flat. Ask your trailer sales or rental agency where and how to store the trailer's spare tire.

### Driving Safely With a Trailer

For your safety and the safety of others, take time to practice driving maneuvers before heading for the open road, and follow the guidelines below.

- Towing performance can be affected by high altitude, high temperature, or when climbing steep grades. Therefore, premium fuel is recommended when towing more than 3,500 lbs (1,590 kg).
- Avoid towing a trailer during your vehicle's first 600 miles (1,000 km).
- Drive slower than normal in all driving conditions.
- Make turns more slowly and wider than normal. The trailer has a smaller arc and it can hit or run over something the vehicle misses.

- Allow more time and distance for braking. Do not brake or turn suddenly — the trailer could jackknife or turn over.
- When driving with a fix-sided (e.g. camper, utility) trailer, do not exceed 55 mph (88 km/h). At higher speeds, the trailer may sway or affect vehicle handling.
- When being passed by a truck or large vehicle, cross-winds and air turbulence can disrupt your steering and cause your trailer to sway. Keep a constant speed, steer straight ahead, and do not try to make quick steering or braking corrections.

- Do not park on an incline unless it is unavoidable. If you must, turn the vehicle's wheels toward the curb on a downhill or away from the curb on an uphill. After parking, place wheel chocks at each trailer tire on the downhill side.

### ***Backing Up***

Always drive slowly and have someone guide you when backing up. Grip the *bottom* of the steering wheel; then turn the wheel to the left to get the trailer to move to the left, and turn the wheel right to move the trailer to the right.

### ***Retrieving a Boat***

If the vehicle's wheels slip when retrieving a boat from the water, shift to first gear, and turn on VTM-4 Lock (see page 142). Disengage VTM-4 Lock as soon as the boat is out of the water to prevent damage to the VTM-4 system.

### ***Driving on Hills***

When climbing hills, closely watch your temperature gauge. If it nears the red (Hot) mark, reduce speed and, if necessary, pull to the side of the road and let the engine cool.

If the transmission shifts frequently while going up a hill, shift down one gear.

If you must stop when facing uphill, use the foot brake or the parking brake. Do not try to hold the vehicle in place by pressing on the accelerator; this could cause the automatic transmission to overheat.

When driving down hills, reduce your speed and shift down to D3. Do not “ride” the brakes.

**Remember: It will take longer to slow down and stop when towing a trailer.**

## Towing Your Vehicle Behind a Motorhome

---

Your Pilot can be towed behind a motorhome at legal highway speeds up to 65 mph (100 km/h). Do not exceed 65 mph (100 km/h) or severe transmission damage will occur. To avoid damage to the 4WD system, it must be towed with all four wheels on the ground (flat towing).

When purchasing a tow bar, make sure you select a reputable manufacturer. Follow the manufacturer's attachment instructions carefully.

Perform the following procedure everyday immediately before you begin towing. Otherwise severe automatic transmission damage will occur.

- Check the transmission fluid level (see page [176](#)). *Do not overfill.*
- Start the engine.

- Press on the brake pedal. Move the shift lever through all its positions.
- Shift to D, then to N. Let the engine run for three minutes, then turn it off.
- Release the parking brake.
- Leave the ignition switch in ACCESSORY (I) so the steering wheel does not lock. Make sure the radio and any items plugged into the accessory power sockets are turned off so you do not run down the battery.

### ***Extended Towing***

If you tow more than 8 hours in one day, you should repeat the above procedure at least every 8 hours (when you stop for fuel, etc.)

**NOTICE:** *Improper towing preparation will damage the transmission. Follow the above procedure exactly. If you cannot shift the transmission or start the engine, your vehicle must be transported on a flat-bed or trailer.*

**NOTICE:** *The steering system can be damaged if the steering wheel is locked. Leave the ignition switch in ACCESSORY (I), and make sure the steering wheel turns freely before you begin towing.*

Your vehicle has been designed primarily for use on pavement. But its higher ground clearance and four-wheel drive VTM-4 system allow you to occasionally travel on unpaved roads, to campgrounds, picnic sites, and similar locations. It is not designed for trailblazing, mountain climbing, or other challenging off-road activities.

If you decide to drive on unpaved roads, you will find that it requires somewhat different driving skills. Your vehicle will also handle somewhat differently than it does on pavement. Be sure to pay extra attention to the precautions and tips in this section, and get acquainted with your vehicle before leaving the pavement.

### **⚠ WARNING**

Improperly operating this vehicle on or off-pavement can cause an accident or rollover in which you and your passengers could be seriously injured or killed.

- Follow all instructions and guidelines in the owner's manual.
- Keep your speed low and don't drive faster than conditions permit.

### **Important Safety Precautions**

To avoid loss of control or rollover, be sure to follow all precautions and recommendations.

- Be sure to store cargo properly and do not exceed your vehicle cargo load limits (see pages [132](#) and [147](#) ).
- Wherever you drive, make sure you and your passengers always wear seat belts.
- Keep your speed low, and never go faster than the conditions allow.
- It's up to you to continually assess the situation and drive within the limits.

## Off-Highway Driving Guidelines

---

### Check Out Your Vehicle

Before you leave the pavement, be sure to do all scheduled maintenance and service and that you inspect your vehicle. Pay special attention to the condition of the tires and check the tire pressure.

After you return to the pavement, carefully inspect your vehicle to make sure there is no damage that could make driving it unsafe.

Recheck the condition of the tires and the tire pressure.

### Remember:

The route presents limits (too steep or bumpy roads). You have limits (driving skill and comfort). And your vehicle has limits (traction, stability, and power).

Driving off-highway can be hazardous if you fail to recognize limits and take the proper precautions.

### Accelerating and Braking

For better traction on all surfaces, accelerate slowly and gradually build up speed. If you try to start too fast on wet soil, mud, snow, or ice, you might not have enough traction to get underway and you may dig yourself a hole. Starting with the shift lever in second gear (2) will help you have a smoother start on snow and ice.

Keep in mind that you will usually need more time and distance to brake to a stop on unpaved surfaces. Avoid hard braking. Do not pump the brakes; let the anti-lock braking system pump them for you.

### Avoiding Obstacles

Debris in the road can damage your suspension or other components. Because your vehicle has a high center of gravity, driving over a large obstacle, or allowing a wheel to drop into a deep hole can cause your vehicle to tip or roll over.

### Driving on Slopes

If you can't clearly see all road conditions or obstacles, walk the slope before you drive on it. If you have any doubt whether or not you can safely drive on the slope, don't do it. Find another route.

If you are driving up a hill and find that you cannot continue, *do not try to turn around*. Your vehicle could roll over. Slowly back down the hill, following the same route you took up the hill.



### Crossing a Stream

Before driving through water, stop and make sure that:

- The water is not deep enough to cover your wheel hubs, axles or exhaust pipe. You could stall and not be able to restart your engine. The water can also damage important vehicle components.
- The banks are sloped so you can drive out.
- The water is not flowing too fast. Deep rushing water can sweep you downstream. Even very shallow rushing water can wash the ground from under your tires and cause you to lose traction and possibly roll over.
- The banks and surface under the water provide good traction. The water may hide hazards such as rocks, holes, or mud.

If you decide it is safe to drive through water, choose a suitable speed and engage the VTM-4 Lock. Proceed without shifting or changing speeds, and do not stop the vehicle or shut off the engine.

After driving through water, test your brakes. If they got wet, gently pump them while driving slowly until they operate normally.

If the water is deeper than the wheel hubs, some additional service may be required. This service is not covered by your warranties.

### If You Get Stuck

If you get stuck, engage the VTM-4 Lock (see page 142 ). Carefully try to go in the direction (forward or reverse) that you think will get you unstuck. Do not spin the tires at high speeds. It will not help you get out and may cause damage to the transmission or VTM-4 system.

If you are unable to free yourself, your vehicle is equipped with front and rear tow hooks designed for this purpose.

Use a nylon strap to attach the Pilot to the recovery vehicle and carefully take out the slack in the strap. Once the strap is tight, the recovery vehicle should apply force. Remember that the recovery vehicle needs good traction to avoid becoming stuck, too.

*CONTINUED*

## Off-Highway Driving Guidelines

---

You should never use a jack to try to get unstuck. Your vehicle could easily slip off the jack and hurt you or someone else.

### **Towing a Trailer Off-Road**

You may be able to safely tow a lightweight trailer (such as a motorcycle or small tent trailer) off-road if you follow these guidelines.

- Do not exceed 1,000 lbs (450 kg) or a tongue weight of 100 lbs (45 kg).
- Try to stay on smooth, level dirt roads, and avoid driving in hilly terrain.
- Allow extra room for starting, stopping, and turning.
- Slow down if you encounter bumps or other obstacles.

This section explains why it is important to keep your vehicle well maintained and how to follow basic maintenance safety precautions.

This section also includes Maintenance Schedules for normal driving and severe driving conditions, a Maintenance Record, and instructions for simple maintenance tasks you may want to take care of yourself.

If you have the skills and tools to perform more complex maintenance tasks on your Honda, you may want to purchase the Service Manual. See page [233](#) for information on how to obtain a copy, or see your Honda dealer.

Maintenance Safety.....	160
Maintenance Schedule.....	161
Maintenance Record .....	167
Fluid Locations.....	170
Adding Engine Oil .....	171
Changing the Oil and Filter.....	172
Engine Coolant.....	174
Windshield Washers .....	175
Automatic Transmission Fluid.....	176
Differential Oil .....	177
Timing Belt.....	177
Brake Fluid .....	178
Power Steering Fluid.....	179
Lights .....	180
Floor Mats .....	185
Cleaning Seat Belts.....	185
Wiper Blades.....	186
Tires .....	188
Checking Your Battery .....	193
Vehicle Storage .....	194

## Maintenance Safety

---

All service items not detailed in this section should be performed by a Honda technician or other qualified mechanic.

### Important Safety Precautions

To eliminate potential hazards, read the instructions before you begin, and make sure you have the tools and skills required.

- Make sure your vehicle is parked on level ground, the parking brake is set, and the engine is off.
- To clean parts, use a commercially available degreaser or parts cleaner, not gasoline.
- To reduce the possibility of fire or explosion, keep cigarettes, sparks, and flames away from the battery and all fuel-related parts.
- Wear eye protection and protective clothing when working

with the battery or compressed air.

### WARNING

Improperly maintaining this vehicle or failing to correct a problem before driving can cause a crash in which you can be seriously hurt or killed.

Always follow the inspection and maintenance recommendations, and schedules in this owner's manual.

### Potential Vehicle Hazards

- **Carbon Monoxide poison from engine exhaust.** Be sure there is adequate ventilation whenever you operate the engine.
- **Burns from hot parts.** Let the engine and exhaust system cool before touching any parts.

- **Injury from moving parts.** Do not run the engine unless instructed to do so.

### WARNING

Failure to properly follow maintenance instructions and precautions can cause you to be seriously hurt or killed.

Always follow the procedures and precautions in this owner's manual.

Some of the most important safety precautions are given here. However, we cannot warn you of every conceivable hazard that can arise in performing maintenance. Only you can decide whether or not you should perform a given task.

### Maintenance Schedule

The maintenance schedule assumes you will use your vehicle as normal transportation for passengers and their possessions. You should also follow these recommendation:

- Avoid exceeding your vehicle's load limit. This puts excess stress on the engine, brakes, and many other vehicle parts. The load limit is shown on the tire information label on the driver's doorjamb.
- Operate your vehicle on reasonable roads within the legal speed limit.
- Drive your vehicle regularly over a distance of several miles (kilometers).
- Always use unleaded gasoline with the proper octane rating (see page 112 ).

### Which Schedule to Follow

Service your vehicle according to the time and mileage periods on one of the Maintenance Schedules on the following pages.

**U.S. Owners** — Follow the Maintenance Schedule for Severe Conditions if you drive your vehicle **MAINLY** under one or more of the following conditions.

- Driving less than 5 miles (8 km) per trip or, in freezing temperatures, driving less than 10 miles (16 km) per trip.
- Driving in extremely hot [over 90°F (32°C)] conditions.
- Used primarily as a delivery vehicle or taxi that is driven mostly in stop-and-go traffic and/or parked with the engine idling.

- Trailer towing, driving with a roof top carrier, or driving in mountainous conditions.
- Driving on muddy, dusty, or de-iced roads.

**NOTE:** If you only *OCCASIONALLY* drive under a “severe” condition, you should follow the Normal Conditions Maintenance Schedule.

**Canadian Owners** — Follow the Maintenance Schedule for Severe Conditions.

## Maintenance Schedule

---

### **Servicing Your Vehicle**

Your authorized Honda dealer knows your vehicle best and can provide competent, efficient service. However, service at a dealer is not mandatory to keep your warranties in effect. Maintenance may be done by any qualified service facility or skilled person to keep your warranties in effect. Keep all the receipts as proof of completion, and have the person who does the work fill out the Maintenance Record. Check your warranty booklet for more information.

We recommend the use of Honda parts and fluids whenever you have maintenance done.

**U.S. Vehicles:** Maintenance, replacement, or repair of emissions control devices and systems may be done by any automotive repair establishment or individual using parts that are “certified” to EPA standards.

According to state and federal regulations, failure to perform maintenance on the items marked with # will not void your emissions warranties. However, Honda recommends that all maintenance services be performed at the recommended time or mileage period to ensure long-term reliability.

### Owner's Maintenance Checks

You should check the following items at the specified intervals. If you are unsure of how to perform any check, turn to the appropriate page listed.

- Engine oil level — Check every time you fill the fuel tank. See page [171](#).
- Engine coolant level — Check the radiator reserve tank every time you fill the fuel tank. See page [174](#).
- Automatic transmission — Check the fluid level monthly. See pages [176](#) — [177](#).
- Brakes — Check the fluid level monthly. See page [178](#).
- Tires — Check the tire pressure monthly. Examine the tread for wear and foreign objects. See page [188](#).
- Lights — Check the operation of the headlights, parking lights, taillights, high-mount brake light, and license plate lights monthly. See page [180](#).

Service the items listed at the indicated distance (or time, if given).											
	miles x 1,000	15	30	45	60	75	90	105	120	135	150
	km x 1,000	24	48	72	96	120	144	168	192	216	240
Check engine oil and coolant	Check oil and coolant at each fuel stop										
Check tires	Check inflation and condition once a month										
Replace engine oil	Every 7,500 miles (12,000 km) or every 1 year, whichever comes first										
Rotate tires (follow pattern on page 190)	Every 7,500 miles (12,000 km)										
Replace engine oil filter											
Check front and rear brake wear											
Check parking brake adjustment											
Inspect the following items:											
Tie-rod ends, steering gearbox, and boots											
Suspension components	•	•	•	•	•	•	•	•	•	•	•
Driveshaft boots											
Brake hoses and lines (including ABS)											
All fluid levels and condition of fluids											
Exhaust system <sup>‡</sup>											
Fuel lines and connections <sup>‡</sup>											
Inspect drive belts		•		•		•		•		•	•
Replace dust and pollen filter											
Replace air cleaner element		•		•		•		•		•	•
Replace spark plugs								•			
Inspect valve clearance								•			
Replace automatic transmission fluid* <sup>1</sup>			•		•		•		•		•
Replace VTM-4 rear differential fluid* <sup>2</sup>	•	•			•		•		•		•
Inspect idle speed								•			
Replace timing belt and inspect water pump								•			
Replace engine coolant	At 120,000 miles (192,000 km) or 10 years, then every 60,000 miles (96,000 km) or 5 years										
Replace brake fluid	Every 3 years (independent of mileage)										

Follow the Normal Maintenance Schedule if the severe driving conditions specified in the Severe Conditions Maintenance Schedule on the next page do not apply.

NOTE: If you only OCCASIONALLY drive under a “severe” condition, you should follow the Normal Conditions Maintenance Schedule.

\* 1: At 45,000 miles (72,000 km) or 3 years, then every 30,000 miles (48,000 km) or 2 years.

\* 2: At every 15,000 miles (24,000 km) up to 30,000 miles (48,000 km) or every 1 year, then every 30,000 miles (48,000 km) or 2 years.

# : See information on maintenance and emissions warranty, page 162.



Service the items listed at the indicated distance (or time, if given).													
	miles x 1,000	7.5	15	30	45	60	75	90	105	120	135	150	
	km x 1,000	12	24	48	72	96	120	144	168	192	216	240	
Check engine oil and coolant	Check oil and coolant at each fuel stop												
Check tires	Check inflation and condition once a month												
Replace engine oil filter	Every 3,750 miles (6,000 km) or every 6 months, whichever comes first												
Rotate tires (follow pattern on page 190)	Every 7,500 miles (12,000 km)												
Check front and rear brake wear Inspect the following items: Tie-rod ends, steering gearbox, and boots Suspension components Driveshaft boots	Every 7,500 miles (12,000 km) or every 6 months, whichever comes first												
Check parking brake adjustment Lubricate all hinges, locks and latches Inspect the following items: Brake hoses and lines (including ABS) All fluid levels and condition of fluids Exhaust system <sup>†</sup> , Fuel lines and connections <sup>†</sup> Lights and controls/vehicle underbody			•	•	•	•	•	•	•	•	•	•	•
	<i>(Or every 1 year, whichever comes first)</i>												
Inspect drive belts Replace dust and pollen filter* <sup>1</sup>													
	<i>(Or every 2 years, whichever comes first)</i>												
Replace air cleaner element	Every 15,000 miles (24,000 km) (Use normal schedule except in dusty condition)												
Replace spark plugs Inspect valve clearance										•			
	<i>(Otherwise adjust only if noisy)</i>												
Replace automatic transmission fluid			•	•	•	•	•	•	•	•	•	•	•
	<i>(Or every 2 years, whichever comes first)</i>												
Replace VTM-4 rear differential fluid* <sup>2, *3</sup>	•	•	•	•	•	•	•	•	•	•	•	•	•
Inspect idle speed Replace timing belt <sup>†, **4</sup> and inspect water pump										•			
	<i>(Or every 7 years, whichever comes first)</i>												
Replace engine coolant	120,000 miles (192,000 km) or 10 years, then every 60,000 miles (96,000 km) or 5 years												
Replace brake fluid	Every 3 years (independent of mileage)												

Follow the Severe Maintenance Schedule if you drive your vehicle MAINLY under one or more of the following conditions:

Driving less than 5 miles (8 km) per trip or, in freezing temperatures, driving less than 10 miles (16 km) per trip.

- Driving in extremely hot [over 90°F (32°C)] conditions.
- Extensive idling or long periods of stop and go driving, such as a taxi or a commercial delivery vehicle.
- Trailer towing, driving with a roof rack, or driving in mountainous conditions.
- Driving on muddy, dusty, or de-iced roads.

**Canadian Owners** — Follow the Maintenance Schedule for Severe Conditions.

- \* 1: See dust and pollen filter on page [185](#) for replacement information under special driving conditions.
- \* 2: At every 7,500 miles (12,000 km) up to 15,000 miles (24,000 km) or every 6 months, then every 15,000 miles (24,000 km) or 1 year.
- \* 3: Follow this schedule for rear differential fluid replacement if you use your vehicle for off-highway driving, trailer towing, mainly in stop-and-go driving. Otherwise, use the fluid replacement schedule in the Maintenance Schedule for Normal Conditions.
- \* 4: See timing belt on page [177](#) for replacement information under special driving conditions.
- # : See information on maintenance and emissions warranty, page [162](#).

## Maintenance Record *(for Normal and Severe Schedules)*

You or the servicing dealer can record all completed maintenance here, whether you follow the schedule for normal conditions (page 164) or severe conditions (page 165). Keep the receipts for all work done on your vehicle.

<b>3,750 mi</b> 6,000 km	Signature or dealer stamp	mi/km
		Date
<b>7,500 mi</b> 12,000 km		mi/km
		Date
<b>11,250 mi</b> 18,000 km		mi/km
		Date
<b>15,000 mi</b> 24,000 km		mi/km
		Date
<b>18,750 mi</b> 30,000 km		mi/km
		Date
<b>22,500 mi</b> 36,000 km		mi/km
		Date
<b>26,250 mi</b> 42,000 km		mi/km
		Date
<b>30,000 mi</b> 48,000 km		mi/km
		Date

<b>33,750 mi</b> 54,000 km	Signature or dealer stamp	mi/km
		Date
<b>37,500 mi</b> 60,000 km		mi/km
		Date
<b>41,250 mi</b> 66,000 km		mi/km
		Date
<b>45,000 mi</b> 72,000 km		mi/km
		Date
<b>48,750 mi</b> 78,000 km		mi/km
		Date
<b>52,500 mi</b> 84,000 km		mi/km
		Date
<b>56,250 mi</b> 90,000 km		mi/km
		Date
<b>60,000 mi</b> 96,000 km		mi/km
		Date

## Maintenance Record *(for Normal and Severe Schedules)*

---

63,750 mi 102,000 km	Signature or dealer stamp	mi/km	93,750 mi 150,000 km	Signature or dealer stamp	mi/km
		Date			Date
67,500 mi 108,000 km		mi/km	97,500 mi 156,000 km		mi/km
		Date			Date
71,250 mi 114,000 km		mi/km	101,250 mi 162,000 km		mi/km
		Date			Date
75,000 mi 120,000 km		mi/km	105,000 mi 168,000 km		mi/km
		Date			Date
78,750 mi 126,000 km		mi/km	108,750 mi 174,000 km		mi/km
		Date			Date
82,500 mi 132,000 km		mi/km	112,500 mi 180,000 km		mi/km
		Date			Date
86,250 mi 138,000 km		mi/km	116,250 mi 186,000 km		mi/km
		Date			Date
90,000 mi 144,000 km		mi/km	120,000 mi 192,000 km		mi/km
		Date			Date

## Maintenance Record *(for Normal and Severe Schedules)*

---

<b>123,750 mi</b> 198,000 km	Signature or dealer stamp	mi/km
		Date
<b>127,500 mi</b> 204,000 km		mi/km
		Date
<b>131,250 mi</b> 210,000 km		mi/km
		Date
<b>135,000 mi</b> 216,000 km		mi/km
		Date
<b>138,750 mi</b> 222,000 km		mi/km
		Date
<b>142,500 mi</b> 228,000 km		mi/km
		Date
<b>146,250 mi</b> 234,000 km		mi/km
		Date
<b>150,000 mi</b> 240,000 km		mi/km
		Date

## Fluid Locations

---

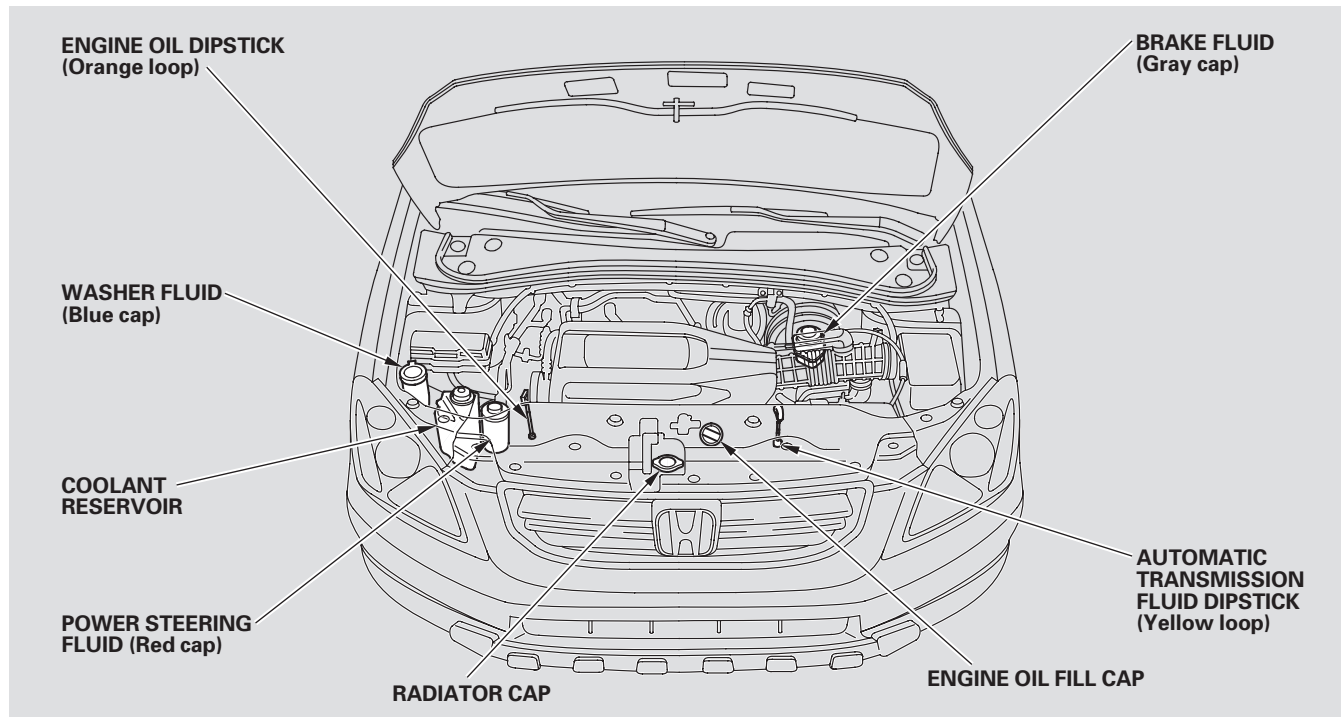

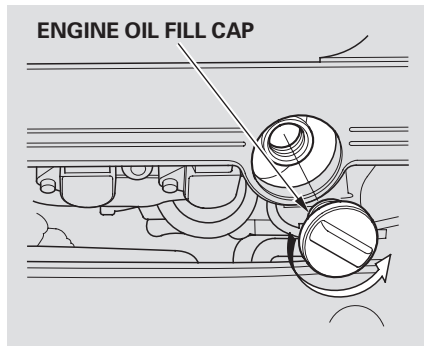

Unscrew and remove the engine oil fill cap on top of the valve cover. Pour in the oil slowly and carefully so you do not spill. Clean up any spills immediately. Spilled oil could damage components in the engine compartment. Install the engine oil fill cap and tighten it securely. Wait a few minutes and recheck the oil level. Do not fill above the upper mark; you could damage the engine.

### Recommended Engine Oil

Oil is a major contributor to your engine's performance and longevity. Always use a premium-grade 5W-20 detergent oil displaying the API Certification Seal. This seal indicates the oil is energy conserving, and that it meets the American Petroleum Institute's latest requirements.



Honda Motor Oil is the preferred 5W-20 lubricant for your vehicle. It is highly recommended that you use Honda Motor Oil in your vehicle for optimum engine protection. Make sure the API Certification Seal says "For Gasoline Engines".

The oil viscosity or weight is provided on the container's label. 5W-20 oil is formulated for year-round protection of your Honda to improve cold weather starting and fuel economy.

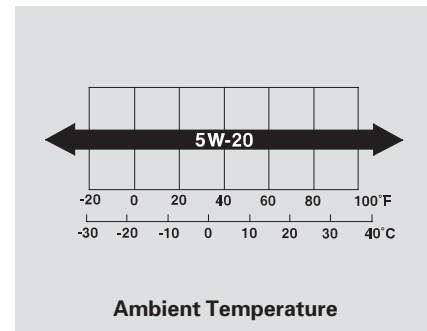

## Adding Engine Oil, Changing the Oil and Filter

---

### Synthetic Oil

You may use a synthetic motor oil if it meets the same requirements given for a conventional motor oil: it displays the API Certification Seal and it is the proper weight. You must follow the oil and filter change intervals given on the maintenance schedule.

### Engine Oil Additives

Your Honda does not require any oil additives. Additives may adversely affect your engine's or transmission's performance and durability.

### Changing the Oil and Filter

Always change the oil and filter according to the recommendations in the maintenance schedule. The oil and filter collect contaminants that can damage your engine if they are not removed regularly.

Changing the oil and filter requires special tools and access from underneath the vehicle. The vehicle should be raised on a service station-type hydraulic lift for this service. Unless you have the knowledge and proper equipment, you should have this maintenance done by a skilled mechanic.

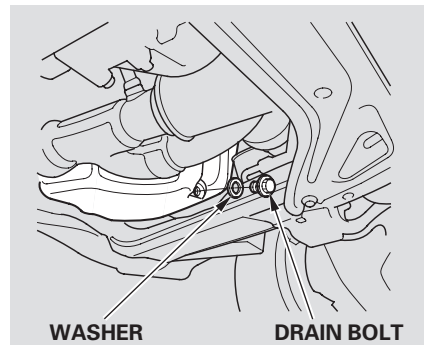

1. Run the engine until it reaches normal operating temperature, then shut it off.
2. Open the hood and remove the engine oil fill cap. Remove the oil drain bolt and washer from the bottom of the engine. Drain the oil into an appropriate container.



### OIL FILTER

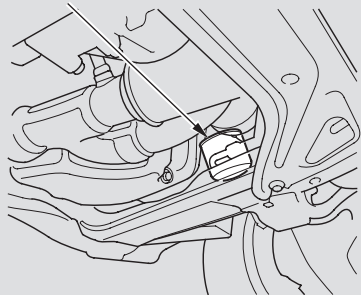

- Remove the oil filter and let the remaining oil drain. A special wrench (available from your Honda dealer) is required.
- Install a new oil filter according to the instructions that come with it.
- Put a new washer on the drain bolt, then reinstall the drain bolt. Tighten it to:  
29 lbf·ft (39 N·m , 4.0 kgf·m)
- Refill the engine with the recommended oil.  
Engine oil change capacity (including filter):  
5.1 US qt (4.8 ℓ)
- Replace the engine oil fill cap. Start the engine. The oil pressure indicator light should go out within 5 seconds. If it does not, turn off the engine and check your work.
- Let the engine run for several minutes, then check the drain bolt and oil filter for leaks.
- Turn off the engine, let it sit for several minutes, then check the oil level on the dipstick. If necessary, add more oil.

**NOTICE:** *Improper disposal of engine oil can be harmful to the environment. If you change your own oil, please dispose of the used oil properly. Put it in a sealed container and take it to a recycling center. Do not discard it in a trash bin or dump it on the ground.*

# Engine Coolant

## Adding Engine Coolant

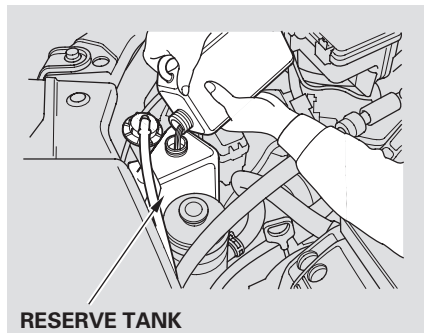

If the coolant level in the reserve tank is at or below the MIN line, add coolant to bring it up to the MAX line. Inspect the cooling system for leaks. Always use Honda All Season Antifreeze/Coolant Type 2. This coolant is pre-mixed with 50 percent antifreeze and 50 percent water. Never add straight antifreeze or plain water.

If Honda antifreeze/coolant is not available, you may use another major-brand non-silicate coolant as a temporary replacement. Make sure it is a high-quality coolant recommended for aluminum engines. Continued use of any non-Honda coolant can result in corrosion, causing the cooling system to malfunction or fail. Have the cooling system flushed and refilled with Honda antifreeze/coolant as soon as possible.

If the reserve tank is completely empty, you should also check the coolant level in the radiator.

### **⚠ WARNING**

Removing the radiator cap while the engine is hot can cause the coolant to spray out, seriously scalding you.

Always let the engine and radiator cool down before removing the radiator cap.

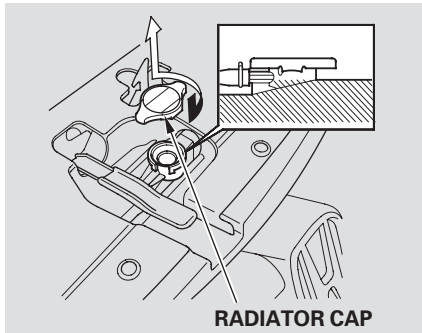

1. When the radiator and engine are cool, relieve any pressure in the cooling system by turning the radiator cap counterclockwise, without pressing down.
2. Remove the radiator cap by pushing down and turning counterclockwise.

3. The coolant level should be up to the base of the filler neck. Add coolant if it is low. Pour the coolant slowly and carefully so you do not spill. Clean up any spill immediately; it could damage components in the engine compartment.
4. Put the radiator cap back on and tighten it.
5. Pour coolant into the reserve tank. Fill it to halfway between the MAX and MIN marks. Put the cap back on the reserve tank.

Do not add any rust inhibitors or other additives to your vehicle's cooling system. They may not be compatible with the coolant or engine components.

### Windshield Washers

Check the fluid level in the windshield washer reservoir at least monthly during normal use.

*On Canadian models:* The low washer level indicator will light when the level is low.

Fill the reservoir with a good-quality windshield washer fluid. This increases the cleaning capability and prevents freezing in cold weather. When you refill the reservoir, clean the edges of the windshield wiper blades with windshield washer fluid on a clean cloth. This will help to condition them.

**NOTICE:** Do not use engine antifreeze or a vinegar/water solution in the windshield washer reservoir. Antifreeze can damage your vehicle's paint, while a vinegar/water solution can damage the windshield washer pump. Use only commercially-available windshield washer fluid.

# Automatic Transmission Fluid

## Automatic Transmission

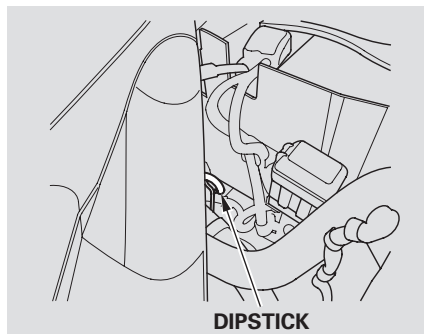

Check the fluid level with the engine at normal operating temperature.

1. Park the vehicle on level ground. Shut off the engine.
2. Remove the dipstick (yellow loop) from the transmission, and wipe it with a clean cloth.

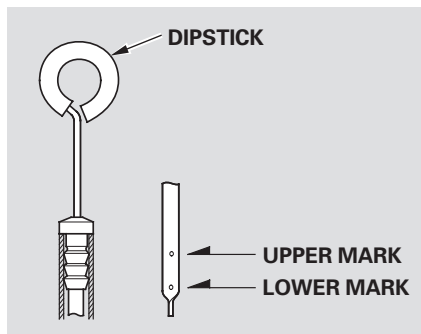

3. Insert the dipstick all the way into the transmission.
4. Remove the dipstick and check the fluid level. It should be between the upper and lower marks.

5. If the level is below the lower mark, add fluid into the tube to bring it to the upper mark.

Always use Honda ATF-Z1 (Automatic Transmission Fluid). If it's not available, you may use a DEXRON® III automatic transmission fluid as a temporary replacement. However, continued use can affect the shift quality. Have the transmission flushed and refilled with Honda ATF-Z1 as soon as it is convenient.

## Automatic Transmission Fluid, Differential Oil, Timing Belt

To thoroughly flush the transmission, the technician should drain and refill it with Honda ATF-Z1 (Automatic Transmission Fluid), then drive the vehicle for a short distance. Do this three times. Then drain and refill the transmission a final time.

6. Insert the dipstick all the way back into the transmission.

The transmission should be drained and refilled with new fluid according to the time and distance recommendations in the maintenance schedule.

If you are not sure how to add fluid, contact your Honda dealer.

### Differential Oil

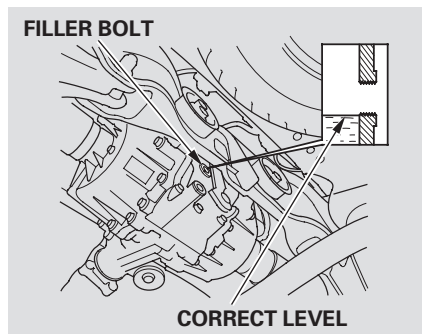

Check the fluid level with the differential at normal operating temperature and the vehicle sitting on level ground. Remove the differential fluid filler bolt and washer, and carefully feel inside the bolt hole with your finger. The fluid level should be up to the edge of the bolt hole. If it is not, slowly add VTM-4 Differential Fluid until it starts to run out of the hole.

Put a new washer on the filler bolt, then reinstall the filler bolt and tighten it securely. Tightening torque:  
33 lbf·ft (45 N·m , 4.6 kgf·m)

The differential should be drained and refilled with new fluid according to the time and distance recommendations in the maintenance schedule.

### Timing Belt

The timing belt should be replaced at the intervals shown in the maintenance schedule. Replace the belt at 60,000 miles (100,000 km) if you regularly drive your vehicle in one or more of these conditions:

- In very high temperatures (over 110°F, 43°C).
- In very low temperatures (under -20°F, -29°C).
- Frequently tow a trailer.

## Brake Fluid

---

Check the brake fluid level in the reservoirs monthly. Replace it according to the time recommendation in the maintenance schedule.

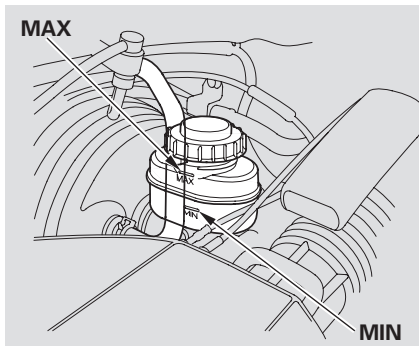

The fluid level should be between the MIN and MAX marks on the side of the reservoir. If the level is at or below the MIN mark, your brake system needs attention. Have the brake system inspected for leaks or worn brake pads.

Always use Honda Heavy Duty Brake Fluid DOT 3. If it is not available, you should use only DOT 3 or DOT 4 fluid, from a sealed container, as a temporary replacement.

Using any non-Honda brake fluid can cause corrosion and decrease the life of the system. Have the brake system flushed and refilled with Honda Heavy Duty Brake Fluid DOT 3 as soon as possible.

Brake fluid marked DOT 5 is not compatible with your vehicle's braking system and can cause extensive damage.

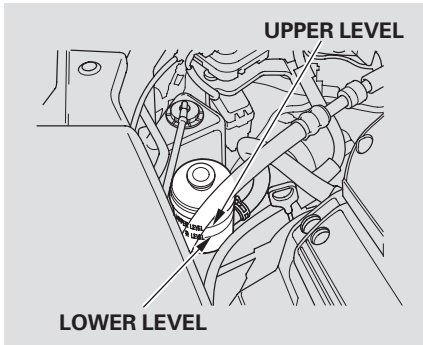

Check the level on the side of the reservoir when the engine is cold. The fluid should be between the UPPER LEVEL and LOWER LEVEL. If not add power steering fluid to the UPPER LEVEL mark.

Always use Honda Power Steering Fluid. You may use another power steering fluid as an emergency replacement, but have the power steering system flushed and refilled with Honda PSF as soon as possible.

A low power steering fluid level can indicate a leak in the system. Check the fluid level frequently, and have the system inspected as soon as possible.

**NOTICE:** *Turning the steering wheel to full left or right lock and holding it there can damage the power steering pump.*

# Lights

## Headlight Aiming

The headlights were properly aimed when your vehicle was new. If you regularly carry heavy items in the trunk, readjustment may be required. Adjustments should be performed by a Honda dealer or other qualified mechanic.

## Replacing a Headlight Bulb

Your vehicle has halogen headlight bulb. Handle it by its steel base and protect the glass from contact with your skin or hard objects. If you touch the glass, clean it with denatured alcohol and a clean cloth.

**NOTE:** Halogen headlight bulbs get very hot when lit. Oil, perspiration, or a scratch on the glass can cause the bulb to overheat and shatter.

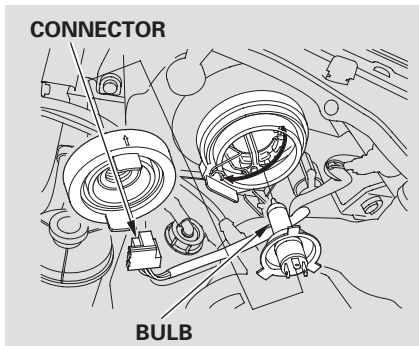

1. Remove the electrical connector from the bulb by pulling the connector straight back.
2. Remove the rubber weather seal by pulling on the tab.
3. Unclip the end of the hold-down wire from its slot. Pivot it out of the way, and remove the bulb.
4. Insert the new bulb and make sure it is right side up. The tabs on the base fit into the indentations in the headlight assembly. Pivot the hold-down wire back in place, and clip the end into the slot.
5. Reinstall the rubber seal and make sure one of its arrow is pointing up.
6. Push the electrical connector onto the new bulb.



## Replacing a Front Turn Signal/ Parking Light Bulb

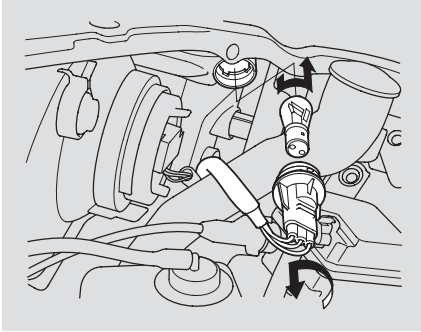

1. Remove the socket from the headlight assembly by turning it one-quarter turn counterclockwise.
2. To remove the front turn signal bulb, push it in slightly and turn it counterclockwise.
3. Install the new bulb into the socket and reinstall it.
4. Insert the socket back into the headlight assembly. Turn it clockwise to lock it in place.
5. Turn on the lights to make sure the new bulb is working.

# Lights

## Replacing Rear Bulbs

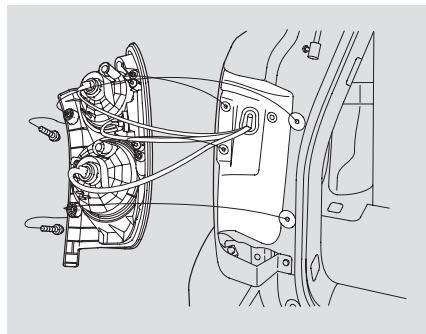

1. Open the tailgate.
2. Remove the two screws, then pull the rear light assembly straight back to remove it from the body.
3. Remove the socket of the burned out bulb by turning it one-quarter turn counterclockwise, and pull it straight out of its socket.

4. Install a new bulb into the socket and reinstall the socket into the light assembly.

## Replacing the High-mount Brake Light

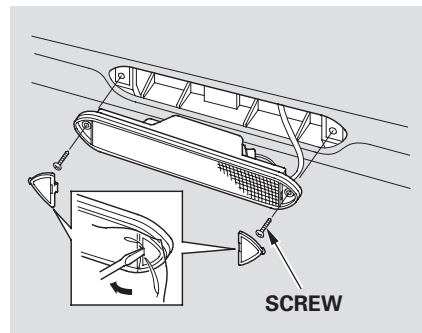

1. Place a cloth on the middle edge of a part of the lens on the passenger's side. Remove a part of the lens by carefully prying on its edge with a small flip tipped screwdriver.
2. Use a Phillips-head screwdriver to remove the screw under the lens.

3. Pull the light assembly out of the tailgate.
4. Remove the socket from the light assembly by turning it one-quarter turn counterclockwise.
5. Pull the bulb straight out of its socket. Push a new bulb into the socket until it bottoms. Reinstall the assembly.

## Replacing a Front Side Marker Light Bulb

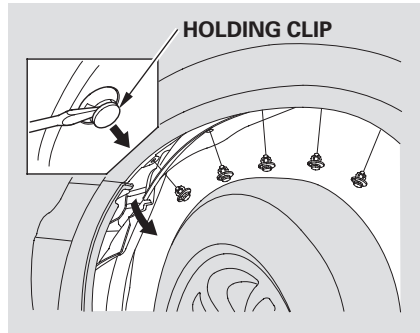

1. If you are changing the bulb on the driver's side, start the engine, turn the steering wheel all the way to the right, and turn off the engine. If you are changing the bulb on the passenger's side, turn the steering wheel to the left.

2. Use a flat-tipped screwdriver to remove the five holding clips from the inner fender.

*CONTINUED*

## Lights

---

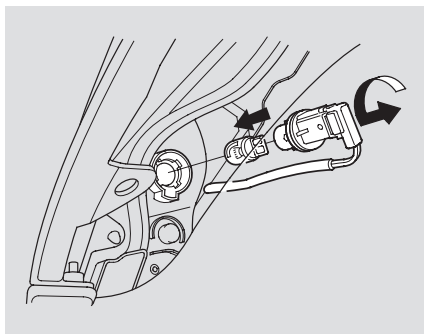

3. Pull the inner fender cover away from the fender and bumper.
4. Remove the socket from the headlight assembly by turning it one-quarter turn counterclockwise.
5. Pull the burned out bulb straight out of its socket. Push the new bulb straight into the socket until it bottoms.
6. Insert the socket back into the headlight assembly. Turn it clockwise to lock it in place.
7. Turn on the lights to make sure the new bulb is working.
8. Put the inner fender in place. Install the five holding clips. Lock each clip in place by pushing on the center.

### Floor Mats

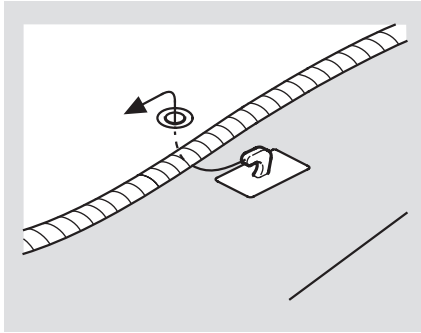

The driver's floor mat that came with your vehicle hooks over the floor mat anchor. This keeps the floor mat from sliding forward and possibly interfering with the pedals.

If you remove the driver's floor mat, make sure to re-anchor it when you put it back in your vehicle.

If you use a non-Honda floor mat, make sure it fits properly and that it can be used with the floor mat anchor. Do not put additional floor mats on top of the anchored mat.

### Cleaning Seat Belts

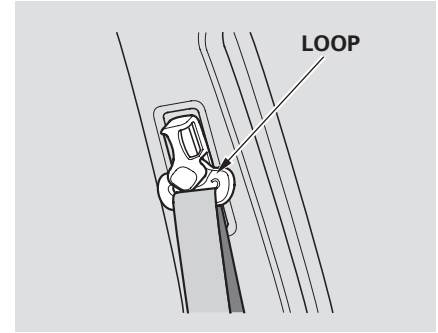

If your seat belts get dirty, use a soft brush with a mixture of mild soap and warm water to clean them. Do not use bleach, dye, or cleaning solvents. Let the belts air dry before you use the vehicle.

Dirt build-up in the loops of the seat belt anchors can cause the belts to retract slowly. Wipe the insides of the loops with a clean cloth dampened in mild soap and warm water or isopropyl alcohol.

## Wiper Blades

Check the condition of the wiper blades at least every six months. Replace them if you find signs of cracking in the rubber, areas that are getting hard, or if they leave streaks and unwiped areas when used.

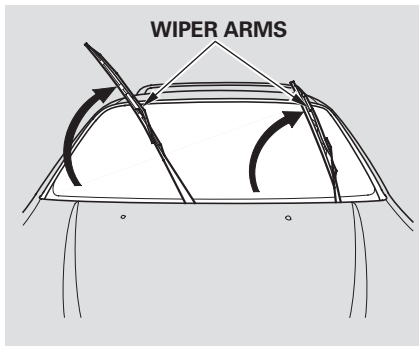

1. Raise the wiper arm off the windshield. Raise the driver's side first, then the passenger's side.

### NOTICE

*Do not open the hood when the wiper arms are raised, or you will damage the hood and wiper arms.*

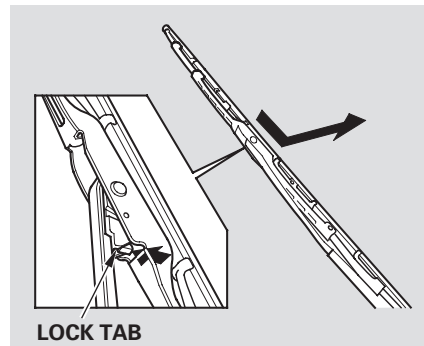

2. Front only:  
Disconnect the blade assembly from the wiper arm by pushing in the lock tab. Hold the lock tab in while you push the blade assembly toward the base of the arm.

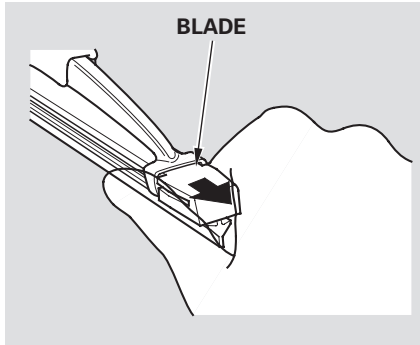

3. Remove the blade from its holder by grasping the tabbed end of the blade. Pull firmly until the tabs come out of the holder.

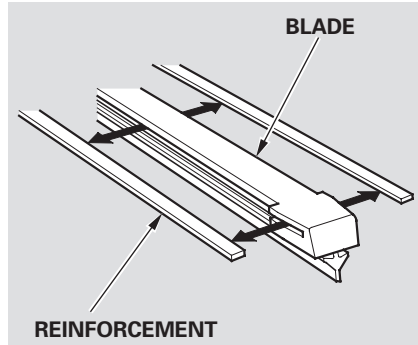

4. Examine the new wiper blades. If they have no plastic or metal reinforcement along the back edge, remove the metal reinforcement strips from the old wiper blade, and install them in the slots along the edge of the new blade.

5. Slide the new wiper blade into the holder until the tabs lock.
6. Front only:  
Slide the wiper blade assembly onto the wiper arm. Make sure it locks in place.
7. Lower the wiper arm down against the windshield. Lower the passenger's side first, then the driver's side.

# Tires

## Tires

To safely operate your vehicle, your tires must be the proper type and size, in good condition with adequate tread, and correctly inflated.

The following pages give more detailed information on how to take care of your tires and what to do when they need to be replaced.

### **WARNING**

Using tires that are excessively worn or improperly inflated can cause a crash in which you can be seriously hurt or killed.

Follow all instructions in this owner's manual regarding tire inflation and maintenance.

## Inflation

Keeping the tires properly inflated provides the best combination of handling, tread life, and riding comfort.

- Underinflated tires wear unevenly, adversely affect handling and fuel economy, and are more likely to fail from being overheated.
- Overinflated tires can make your vehicle ride more harshly, are more prone to damage from road hazards, and wear unevenly.

We recommend that you visually check your tires every day. If you think a tire might be low, check it immediately with a tire gauge.

Tire Size	Cold Tire Pressure for Normal Driving
P235/70R16 104S	32 psi (220 kPa , 2.2 kgf/cm <sup>2</sup> )

The compact spare tire pressure is: **60 psi (420 kPa , 4.2 kgf/cm<sup>2</sup>)**

For convenience, the recommended tire sizes and cold air pressures are on a label on the driver's doorjamb.

For additional technical information, see page [220](#) .

Use a gauge to measure the air pressure at least once a month. Even tires that are in good condition may lose one to two psi (10 to 20 kPa, 0.1 to 0.2 kgf/cm<sup>2</sup>) per month.

Remember to check the spare tire at the same time.



Check the pressure in the tires when they are cold. This means the vehicle has been parked for at least three hours, or driven less than 1 mile (1.6 km).

Tire pressure for high speed driving is the same as for normal driving.

If you check the pressure when the tires are hot (driven for several miles), you will see readings 4 to 6 psi (30 to 40 kPa, 0.3 to 0.4 kgf/cm<sup>2</sup>) higher than the cold reading. This is normal; do not release air to match the cold pressure.

Tubeless tires have some ability to self-seal if they are punctured. You should look closely for punctures if a tire starts losing pressure.

You should get your own tire pressure gauge and use it whenever you check your tire pressures. This will make it easier for you to tell if a pressure loss is due to a tire problem and not due to a variation between gauges.

## **Tire Inspection**

Every time you check inflation, you should also examine the tires for damage, foreign objects, and wear. You should look for:

- Bumps or bulges in the tread or side of the tire. Replace the tire if you find either of these conditions.
- Cuts, splits, or cracks in the side of the tire. Replace the tire if you can see fabric or cord.
- Excessive tread wear.

# Tires

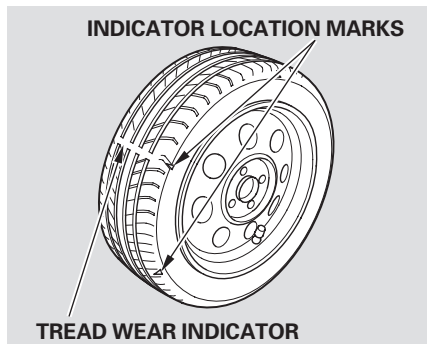

Your vehicle's tires have wear indicators molded into the tread. When the tread wears down to that point, you will see a 1/2 inch (12.7 mm) wide band running across the tread. This shows there is less than 1/16 inch (1.6 mm) of tread left on the tire. A tire that is this worn gives very little traction on wet roads. You should replace the tire if you can see the tread wear indicator in three or more places around the tire.

## Tire Maintenance

In addition to proper inflation, correct wheel alignment helps to decrease tire wear. If you find a tire is worn unevenly, have your dealer check the wheel alignment.

Have your dealer check the tires if you feel a consistent vibration while driving. A tire should always be rebalanced if it is removed from the wheel. When you have new tires installed, make sure they are balanced. This increases riding comfort and tire life. For best results, have the installer perform a dynamic balance.

## Tire Rotation

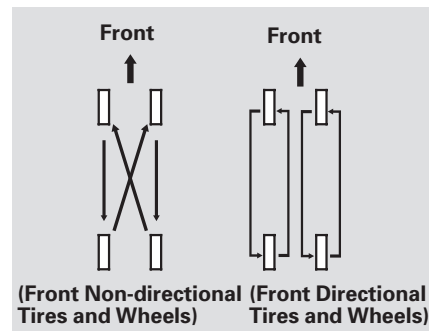

To help increase tire life and distribute wear more evenly, rotate the tires every 7,500 miles (12,000 km). Move the tires to the positions shown in the chart each time they are rotated. If you purchase directional tires, rotate only front-to-back.

## Replacing Tires

Replace your tires with radial tires of the same size, load range, speed rating and maximum cold tire pressure rating (as shown on the tire's side wall).

Mixing radial and bias-ply tires on your vehicle can reduce braking ability, traction, and steering accuracy. Using tires of a different size or construction can cause the ABS to work inconsistently.

It is best to replace all four tires at the same time. If that is not possible or necessary, replace the two front tires or two rear tires as a pair. Replacing just one tire can seriously affect your vehicle's handling.

If you ever replace a wheel, make sure that the wheel's specifications match those of the original wheels.

## WARNING

Installing improper tires on your vehicle can affect handling and stability. This can cause a crash in which you can be seriously hurt or killed.

Always use the size and type of tires recommended in this owner's manual.

## Wheel and Tire Specifications

Wheels:

16 x 6 1/2 JJ

Tires:

P235/70R16 104S

See page [198](#) for DOT tire quality grading information, and page [199](#) for tire size explanation.

## Winter Driving

Tires marked “M + S” or “All Season” on the sidewall have an all-weather tread design suitable for most winter driving conditions.

For the best performance in snowy or icy conditions, you should install snow tires or tire chains. They may be required by local laws under certain conditions.

## Snow Tires

If you mount snow tires on your Honda, make sure they are radial tires of the same size and load range as original tires. Mount snow tires on all four wheels. The traction provided by snow tires on dry roads may be lower than your original tires. Check with the tire dealer for maximum speed recommendations.

# Tires

---

## Tire Chains

Because your Honda has limited tire clearance, mount only SAE Class “S” cable-type traction devices, with rubber chain tensioners on the front tires. Use traction devices only when required by driving condition or local laws. Make sure they are the correct size for your tires. Metal link-type “chains” should not be used.

When installing cables, follow the manufacturer’s instructions, and mount them as tight as you can. Make sure they are not contacting the brake lines or suspension. Drive slowly with them installed. If you hear them coming into contact with the body or chassis, stop and investigate. Remove them as soon as you begin driving on cleared roads.

**NOTICE:** *Traction devices that are the wrong size or improperly installed can damage your vehicle’s brake lines, suspension, body, and wheels. Stop driving if they are hitting any part of the vehicle.*

### TEST INDICATOR WINDOW

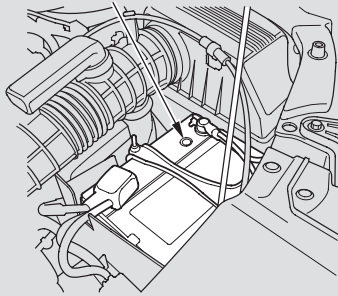

Check the condition of the battery monthly by looking at the test indicator window. The label on the battery explains the test indicator's colors.

Check the terminals for corrosion (a white or yellowish powder). To remove it, cover the terminals with a solution of baking soda and water. It will bubble up and turn brown. When this stops, wash it off with plain water. Dry off the battery with a cloth or paper towel. Coat the terminals with grease to help prevent further corrosion.

If additional battery maintenance is needed, see your Honda dealer or a qualified technician.

**WARNING:** Battery posts, terminals, and related accessories contain lead and lead compounds. **Wash your hands after handling.**

If you need to connect the battery to a charger, disconnect both cables to prevent damaging your vehicle's electrical system. Always disconnect the negative (–) cable first, and reconnect it last.

### **⚠ WARNING**

The battery gives off explosive hydrogen gas during normal operation.

A spark or flame can cause the battery to explode with enough force to kill or seriously hurt you.

Wear protective clothing and a face shield, or have a skilled mechanic do the battery maintenance.

## Vehicle Storage

---

If you need to park your vehicle for an extended period (more than one month), there are several things you should do to prepare it for storage. Proper preparation helps prevent deterioration and makes it easier to get your vehicle back on the road. If possible, store your vehicle indoors.

- Fill the fuel tank.
- Change the engine oil and filter.
- Wash and dry the exterior completely.
- Clean the interior. Make sure the carpeting, floor mats, etc. are completely dry.
- Leave the parking brake off. Put the transmission in Park.

- Block the rear wheels.
- If the vehicle is to be stored for a longer period, it should be supported on jackstands so the tires are off the ground.
- Leave one window open slightly (if the vehicle is being stored indoors).
- Disconnect the battery.
- Support the front wiper blade arms with a folded towel or rag so they do not touch the windshield.
- To minimize sticking, apply a silicone spray lubricant to all door and tailgate seals. Also, apply a vehicle body wax to the painted surfaces that mate with the door and tailgate seals.

- Cover the vehicle with a “breathable” cover, one made from a porous material such as cotton. Non-porous materials, such as plastic sheeting, trap moisture, which can damage the paint.
- If possible, run the engine periodically (preferably once a month).

If you store your vehicle for 12 months or longer, have your Honda dealer perform the inspections called for in the 24 months/30,000 miles maintenance schedule (Normal Conditions) as soon as you take it out of storage (see page [165](#)). The replacements called for in the maintenance schedule are not needed unless the vehicle has actually reached that time or mileage.

## Taking Care of the Unexpected

---

Compact Spare Tire.....	196
Changing a Flat Tire .....	197
If Your Engine Won't Start.....	201
Jump Starting .....	202
If Your Engine Overheats.....	204
Low Oil Pressure Light.....	206
Charging System Indicator.....	206
Malfunction Indicator .....	207
Brake System Indicator .....	208
Emergency Towing .....	208
Fuses .....	209
Fuse Locations.....	212

## Compact Spare Tire

---

Use the compact spare tire as a temporary replacement only. Get your regular tire repaired or replaced and put it back on your vehicle as soon as you can.

Check the inflation pressure of the compact spare tire every time you check the other tires. It should be inflated to:  
60 psi (420 kPa , 4.2 kgf/cm<sup>2</sup>)

Follow these precautions:

- Never exceed 50 mph (80 km/h).
- This tire gives a harsher ride and less traction on some road surfaces. Use greater caution while driving.
- Do not mount snow chains on it.
- Do not use the compact spare tire if you are towing a trailer.
- Do not use your compact spare tire on another vehicle unless it is the same make and model.

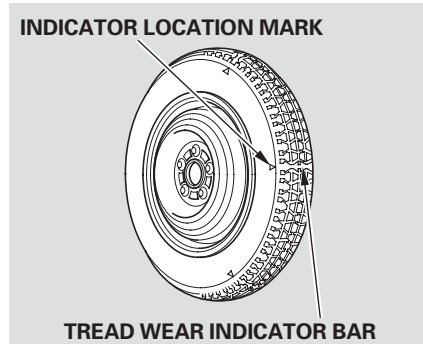

Replace the tire when you can see the tread wear indicator bars. The replacement should be the same size and design tire, mounted on the same wheel. The spare tire is not designed to be mounted on a regular wheel, and the spare wheel is not designed for mounting a regular tire.



## Changing a Flat Tire

If you have a flat tire while driving, stop in a safe place to change it. Drive slowly along the shoulder until you get to an exit or an area that is far away from the traffic lanes.

### **WARNING**

The vehicle can easily roll off the jack, seriously injuring anyone underneath.

Follow the directions for changing a tire exactly, and never get under the vehicle when it is supported only by the jack.

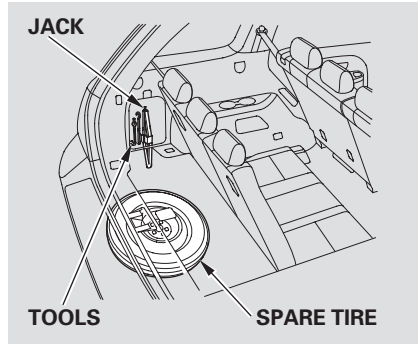

1. Park the vehicle on firm, level, and non-slippery ground. Put the transmission in Park. Apply the parking brake.
2. Turn on the hazard warning lights, and turn the ignition switch to LOCK (0). Have all the passengers get out of the vehicle while you change the tire.

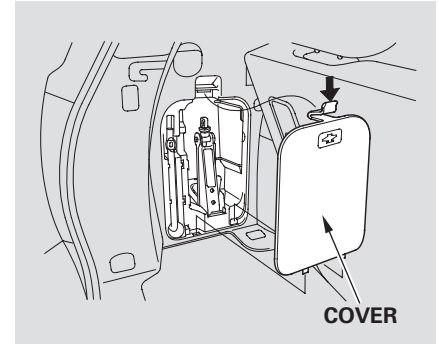

3. The tools and jack are behind a cover in the cargo area on the driver's side. Remove the cover by pushing the top of it.
4. Turn the jack's end counterclockwise to loosen it, then remove the jack and tools.

## Changing a Flat Tire

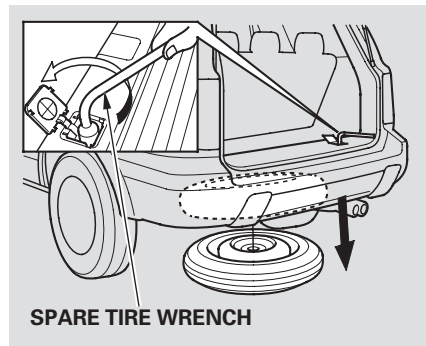

5. The spare tire is stored underneath the rear cargo area. Remove the plastic cover on the cargo area lining to access the shaft for the spare tire hoist.

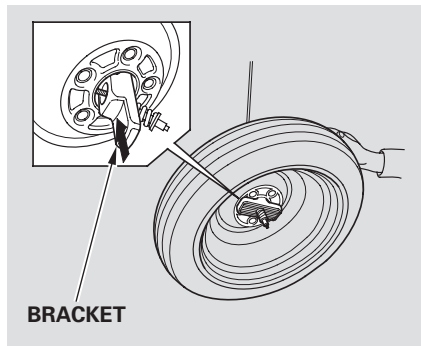

6. Put the wheel nut wrench on the hoist shaft. Turn the wrench counterclockwise to lower the spare tire to the ground. Keep turning the wheel wrench to create slack in the cable.
7. Remove the bracket from the spare tire.
8. Loosen each wheel nut 1/2 turn with the wheel wrench.

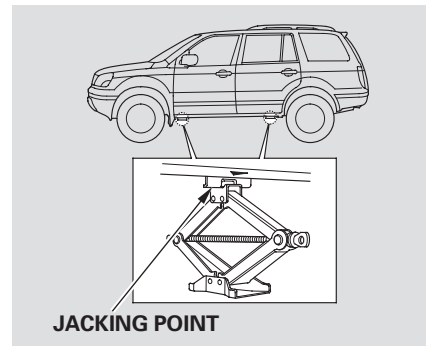

9. Place the jack under the jacking point nearest the tire you need to change. It is pointed to by a  $\triangle$  mark molded into the underside of the body. Turn the end bracket clockwise until the top of the jack contacts the jacking point. Make sure the jacking point tab is resting in the jack notch.

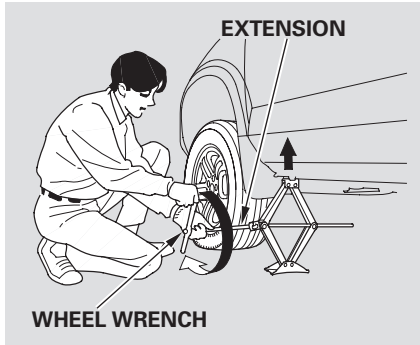

10. Use the extension and wheel wrench as shown to raise the vehicle until the flat tire is off the ground.
11. Remove the wheel nuts, then remove the flat tire. Place the flat tire on the ground with the outside surface facing up.

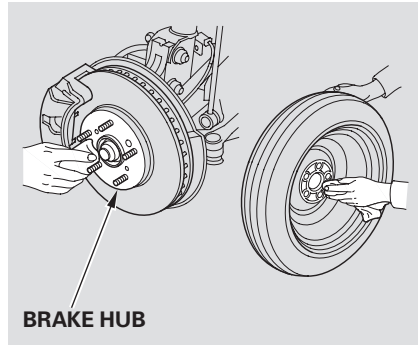

12. Before mounting the spare tire, wipe any dirt off the mounting surface of the wheel and hub with a clean cloth. Wipe the hub carefully; it may be hot from driving.
13. Put on the spare tire. Put the wheel nuts back on finger-tight, then tighten them in a crisscross pattern with the wheel wrench until the wheel is firmly against the hub. Do not try to tighten them fully.

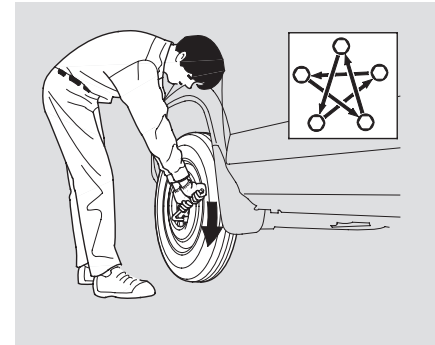

14. Lower the vehicle to the ground and remove the jack.
15. Tighten the wheel nuts securely in the same crisscross pattern. Have the wheel nut torque checked at the nearest automotive service facility.  
Tighten the wheel nuts to:  
80 lbf-ft (108 N·m , 11 kgf·m)
16. Remove the center cap from the flat tire, and place the flat tire up under the hoist.

## Changing a Flat Tire

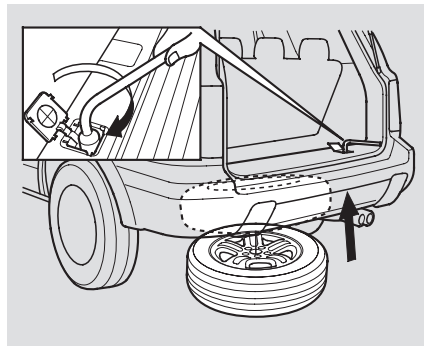

17. Insert the hoist bracket into the center hole of the flat tire.
18. Slowly turn the wheel wrench clockwise to take up the slack of the hoist cable. Make sure the bracket is seated in the center hole of the spare tire.
19. Turn the wheel wrench clockwise until the flat tire rests against the underbody of the vehicle and you hear the hoist click.

**NOTICE:** Always raise the spare tire hoist, even if you are not stowing a tire. If the hoist is left down, it will be damaged during driving and need to be replaced.

20. Store the jack in its holder. Turn the jacks' end bracket to lock it in place and replace the tools and cover.

### **⚠ WARNING**

Loose items can fly around the interior in a crash and could seriously injure the occupants.

Store the wheel, jack, and tools securely before driving.

Diagnosing why your engine won't start falls into two areas, depending on what you hear when you turn the key to START (III):

- You hear nothing, or almost nothing. The engine's starter motor does not operate at all, or operates very slowly.
- You can hear the starter motor operating normally, or the starter motor sounds like it is spinning faster than normal, but the engine does not start up and run.

### **Nothing Happens or the Starter Motor Operates Very Slowly**

When you turn the ignition switch to START (III), you do not hear the normal noise of the engine trying to start. You may hear a clicking sound or series of clicks, or nothing at all. Check these things:

- Check the transmission interlock. The transmission must be in Park or Neutral or the starter will not operate.
- Turn the ignition switch to ON (II). Turn on the headlights and check their brightness. If the headlights are very dim or don't light at all, the battery is discharged. See **Jump Starting** on page 202 .
- Turn the ignition switch to START (III). If the headlights do not dim, check the condition of the fuses. If the fuses are OK, there is probably something wrong with the electrical circuit for the ignition switch or starter motor. You will need a qualified technician to determine the problem (see **Emergency Towing** on page 208 ).

If the headlights dim noticeably or go out when you try to start the engine, either the battery is discharged or the connections are corroded. Check the condition of the battery and terminal connections (see page 193 ). You can then try jump starting the vehicle from a booster battery (see page 202 ).

### **The Starter Operates Normally**

In this case, the starter motor's speed sounds normal, or even faster than normal, when you turn the ignition switch to START (III), but the engine does not run.

- Are you using the proper starting procedure? Refer to **Starting the Engine** on page 137 .

## If the Engine Won't Start, Jump Starting

---

- Are you using a properly coded key? An improperly coded key will cause the immobilizer system indicator in the dash panel to blink rapidly (see page 53).
- Do you have fuel? Check the fuel gauge; the warning light may not be working.
- There may be an electrical problem, such as no power to the fuel pump. Check all the fuses (see page 209).

If you find nothing wrong, you will need a qualified technician to find the problem. See **Emergency Towing** on page 208.

### Jump Starting

Although this seems like a simple procedure, you should take several precautions.

#### **WARNING**

A battery can explode if you do not follow the correct procedure, seriously injuring anyone nearby.

Keep all sparks, open flames, and smoking materials away from the battery.

You cannot start a Honda by pushing or pulling it.

### To Jump Start Your Vehicle:

1. Open the hood and check the physical condition of the battery. In very cold weather, check the condition of the electrolyte. If it seems slushy or like ice, do not try jump starting until it thaws.  
**NOTICE:** *If a battery sits in extreme cold, the electrolyte inside can freeze. Attempting to jump start with a frozen battery can cause it to rupture.*
2. Turn off all the electrical accessories: heater, A/C, climate control, stereo system, lights, etc. Put the transmission in Neutral or Park, and set the parking brake.
3. Connect one jumper cable to the positive (+) terminal on your battery. Connect the other end to the positive (+) terminal on the booster battery.

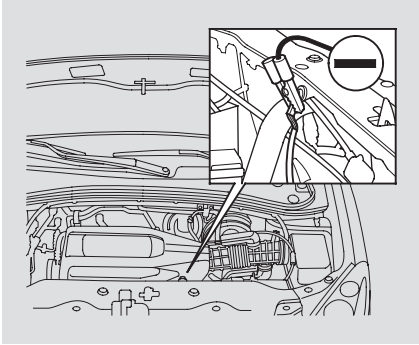

4. Connect the second jumper cable to the negative (–) terminal on the booster battery. Connect the other end to the grounding strap as shown. Do not connect this jumper cable to any other part of the engine.
5. If the booster battery is in another vehicle, have an assistant start that vehicle and run it at a fast idle.

6. Start your vehicle. If the starter motor still operates slowly, check that the jumper cables have good metal-to-metal contact.
7. Once your vehicle is running, disconnect the negative cable from your vehicle, then from the booster battery. Disconnect the positive cable from your vehicle, and then from the booster battery.

Keep the ends of the jumper cables away from each other and any metal on the vehicle until everything is disconnected. Otherwise, you may cause an electrical short.

## If the Engine Overheats

---

The pointer of your vehicle's temperature gauge should stay in the midrange. If it climbs to the red mark, you should determine the reason (hot day, driving up a steep hill, etc.).

If your vehicle overheats, you should take immediate action. The only indication may be the temperature gauge climbing to or above the red mark. Or you may see steam or spray coming from under the hood.

**NOTICE:** *Driving with the temperature gauge pointer at the red mark can cause serious damage to your engine.*

### **WARNING**

Steam and spray from an overheated engine can seriously scald you.

Do not open the hood if steam is coming out.

1. Safely pull to the side of the road. Put the transmission in Neutral or Park, and set the parking brake. Turn off all the accessories, and turn on the hazard indicator.
2. If you see steam and/or spray coming from under the hood, turn off the engine. Wait until you see no more signs of steam or spray, then open the hood.

3. If you do not see steam or spray, leave the engine running and watch the temperature gauge. If the high heat is due to overloading, the engine should start to cool down almost immediately. If it does, wait until the temperature gauge comes down to the midpoint, then continue driving.
4. If the temperature gauge stays at the red mark, turn off the engine.
5. Look for any obvious coolant leaks, such as a split radiator hose. Everything is still extremely hot, so use caution. If you find a leak, it must be repaired before you continue driving (see **Emergency Towing** on page 208).
6. If you don't find an obvious leak, check the coolant level in the radiator reserve tank. Add coolant if the level is below the MIN mark.



7. If there was no coolant in the reserve tank, you may need to add coolant to the radiator. Let the engine cool down until the pointer reaches the middle of the temperature gauge, or lower, before checking the radiator.

### **WARNING**

Removing the radiator cap while the engine is hot can cause the coolant to spray out, seriously scalding you.

Always let the engine and radiator cool down before removing the radiator cap.

8. Using gloves or large heavy cloth, turn the radiator cap counterclockwise without pushing down to the first stop. After the pressure releases, push down on the cap, and turn it until it comes off.

9. Start the engine and set the temperature control dial to maximum (climate control to FULL AUTO at 90°F/32°C). Add coolant to the radiator up to the base of the filler neck. If you do not have the proper coolant mixture available, you can add plain water. Remember to have the cooling system drained and refilled with the proper mixture as soon as you can.

10. Put the radiator cap back on tightly. Run the engine and watch the temperature gauge. If it goes back to the red mark, the engine needs repair (see **Emergency Towing** on page 208).

11. If the temperature stays normal, check the coolant level in the radiator reserve tank. If it has gone down, add coolant to the MAX mark. Put the cap back on tightly.

## Low Oil Pressure Light, Charging System Indicator

---

### Low Oil Pressure Indicator



This light should never come on when the engine is running. If it starts flashing or stays on, the oil pressure has dropped very low or lost pressure. Serious engine damage is possible and you should take immediate action.

**NOTICE:** *Running the engine with low oil pressure can cause serious mechanical damage almost immediately. Turn off the engine as soon as you can safely get the vehicle stopped.*

1. Safely pull off the road, and shut off the engine. Turn on the hazard warning lights.
2. Let the vehicle sit for a minute. Open the hood, and check the oil level (see page [127](#) ). An engine very low on oil can lose pressure during cornering and other driving maneuvers.
3. If necessary, add oil to bring the level back to the full mark on the dipstick (see page [171](#) ).
4. Start the engine, and watch the oil pressure light. If it does not go out within ten seconds, turn off the engine. There is a mechanical problem that needs to be repaired before you can continue driving. (See **Emergency Towing** on page [208](#) ).

### Charging System Indicator



If the charging system indicator comes on brightly when the engine is running, the battery is not being charged.

Immediately turn off all electrical accessories. Try not to use other electrically operated controls such as the power windows. Keep the engine running; starting the engine will discharge the battery rapidly.

Go to a service station or garage where you can get technical assistance.

### **Malfunction Indicator Lamp**



If the indicator comes on while driving, it means one of the engine's emission control systems may have a problem. Even though you may feel no difference in your vehicle's performance, continued operation may cause serious damage.

If you have recently refueled your vehicle, the cause of this indicator coming on could be a loose or missing fuel fill cap. Check the cap or replace it. Tightening the cap will not make the indicator turn off immediately; it takes at least three days of normal driving.

If the indicator remains on or the fuel cap was not loose or missing, have the vehicle checked by the dealer as soon as possible.

**NOTICE:** *If you keep driving with the Malfunction Indicator Lamp on, you can damage your vehicle's emission controls and the engine. Those repairs may not be covered by your vehicle's warranties.*

If the malfunction indicator lamp comes on along with the "D" indicator, there is a problem in the automatic transmission control system.

### **Readiness Code**

Your vehicle has certain "readiness codes" that are part of the on-board diagnostics for the emissions systems. In some states, part of the emissions testing is to make sure these codes are set. If they are not set, the test cannot be completed.

If your vehicle battery has been disconnected or gone dead, these codes are erased. It takes at least three days of driving under various conditions to set the codes again.

To check if they are set, turn the ignition to ON (II), without starting the engine. The Malfunction Indicator Lamp will come on for 20 seconds. If it then goes off, the readiness codes are set. If it blinks 5 times, the readiness codes are not set. If possible, do not take your vehicle for a state emissions test until the readiness codes are set. Refer to State Emissions Testing for more information (see page [226](#)).

## Brake System Indicator, Emergency Towing

---

### Brake System Indicator

**BRAKE** If the brake system indicator comes on while driving, the brake fluid level is probably low in the reservoir. Press lightly on the brake pedal to see if it feels normal. If it does, check the brake fluid level the next time you stop at a service station (see page [178](#)). If the fluid level is low, take the vehicle to your dealer and have the brake system inspected for leaks or worn brake pads.

However, if the brake pedal does not feel normal, you should take immediate action. A problem in one part of the system's dual circuit design will still give you braking at two wheels. You will feel the brake pedal go down much farther before the vehicle begins to slow down and you will have to press harder on the pedal.

Slow down by shifting to a lower gear, and pull to the side of the road when it is safe. Because of the long distance needed to stop, it is hazardous to drive the vehicle. You should have it towed and repaired as soon as possible (see **Emergency Towing** on page [208](#)).

If you must drive the vehicle a short distance in this condition, drive slowly and carefully.

### Emergency Towing

If your vehicle needs to be towed, call a professional towing service or organization. Never tow your vehicle with just a rope or chain. It is very dangerous.

**The only way you can safely tow your vehicle is with flat-bed equipment.** The operator will load your vehicle on the back of a truck. Any other method of towing will damage the drive system. When you contact the towing agency, inform them a flat-bed is required.

**NOTICE:** *Towing a Pilot with only two tires on the ground will damage parts of the 4WD system. It should be transported on a flat-bed truck or trailer.*

Refer to **Towing Your Vehicle Behind a Motorhome** on page [208](#) for non-emergency towing information.

## DRIVER'S SIDE INTERIOR

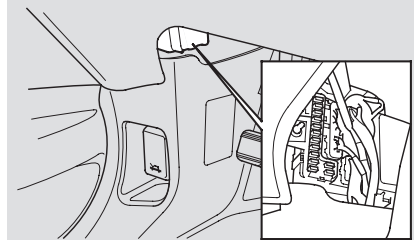

The vehicle's fuses are located in four fuse boxes. The interior fuse boxes are located under the dashboard on the driver's and passenger's side.

## PASSENGER'S SIDE INTERIOR

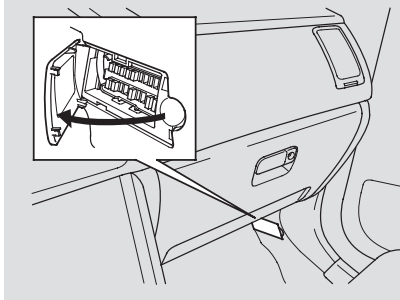

To open the passenger's side, pull the right edge of the cover.

The primary under-hood fuse box is located on the passenger's side. The secondary fuse box is next to the battery.

## UNDER-HOOD FUSE BOXES

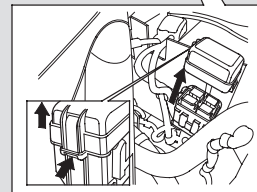
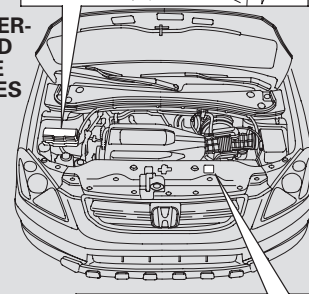
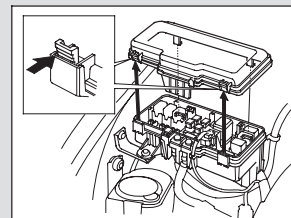

# Fuses

## Checking and Replacing Fuses

If something electrical in your vehicle stops working, the first thing you should check for is a blown fuse. Determine from the chart on pages 212 and 213, or the diagram on the fuse box lid, which fuse or fuses control that device. The diagram for the interior driver's side fuse box is on the kick panel below the fuse box. Check those fuses first, but check all the fuses before deciding that a blown fuse is the cause. Replace any blown fuses, and check if the device works.

1. Turn the ignition switch to LOCK (0). Make sure the headlights and all other accessories are off.
2. Remove the cover from the fuse box.

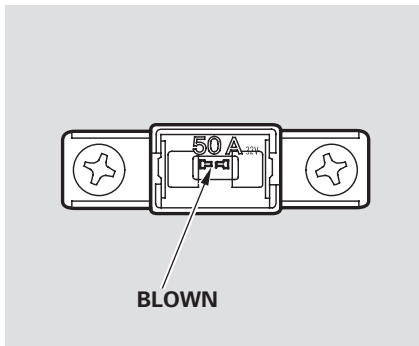

3. Check each of the large fuses in the primary under-hood fuse box by looking through the top at the wire inside. Remove the screws with a Phillips-head screwdriver.

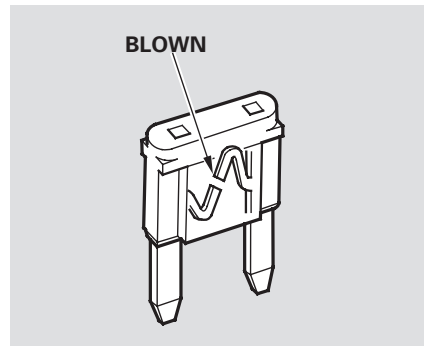

4. Check the smaller fuses in the under-hood fuse box and all the fuses in the interior fuse boxes by pulling out each fuse with the fuse puller provided in the primary under-hood fuse box.
5. Look for a burned wire inside the fuse. If it is burned, replace it with one of the spare fuses of the same rating or lower.

If you cannot drive the vehicle without fixing the problem, and you do not have a spare fuse, take a fuse of the same rating or a lower rating from one of the other circuits. Make sure you can do without that circuit temporarily (such as the accessory power socket or radio).

If you replace the blown fuse with a spare fuse that has a lower rating, it might blow out again. This does not indicate anything wrong. Replace the fuse with one of the correct rating as soon as you can.

**NOTICE:** *Replacing a fuse with one that has a higher rating greatly increases the chances of damaging the electrical system. If you do not have a replacement fuse with the proper rating for the circuit, install one with a lower rating.*

6. If the replacement fuse of the same rating blows in a short time, there is probably a serious electrical problem in your vehicle. Leave the blown fuse in that circuit, and have your vehicle checked by a qualified mechanic.

### *On EX model*

If the radio fuse is removed, the audio system will disable itself. The next time you turn on the radio you will see “COdE” in the frequency display. Use the Preset buttons to enter the five-digit code (see page 102).

### **Trailer Fuses**

If a trailer light is burned out, check if these fuses are blown when you replace the light bulbs:

- Primary under-hood fuse box fuses 5, 7, and 24
- Interior driver’s side fuse box: 10
- Interior passenger’s side fuse box: 10

If those fuses are OK, but the trailer lights still do not work, there are two blown 7.5 amp fuses in the trailer hatch wiring. To access the 7.5 amp fuses:

1. Open the tailgate and remove the cargo floor lid.
2. Pull out the bottom of the tailgate rubber seal.
3. Remove rear trim panel by pulling up on the inside edge of the rear trim panel, and unhooking the four clips and tabs.
4. After replacing fuses, and reinstall the rear trim panel in the reverse order of removal.

# Fuse Locations

## PRIMARY UNDER-HOOD FUSE BOX

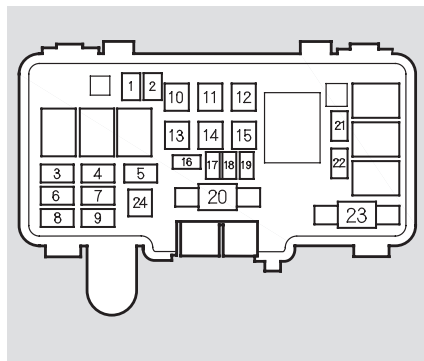

No.	Amps.	Circuits Protected
1	20 A	Spare Fuse
2	30 A	Spare Fuse
3	20 A	Right Headlight
4	15 A	ACG S
5	15 A	Hazard
6	—	Not used
7	20 A	Stop
8	20 A	Left Headlight
9	20 A	Radio
10	40 A	Power Window Motor
11	40 A	Power Seat
12	30 A	Rear Defroster
13	40 A	Back Up, ACC

No.	Amps.	Circuits Protected
14	30 A	Rear A/C
15	40 A	Heater Motor
16	30 A	Cooling Fan
17	7.5 A	Spare Fuse
18	10 A	Spare Fuse
19	15 A	Spare Fuse
20	120 A	Battery
21	30 A	Condenser Fan
22	7.5 A	MG Clutch
23	50 A	IGI Main
24	20 A	Trailer (accessory)

## SECONDARY UNDER-HOOD FUSE BOX

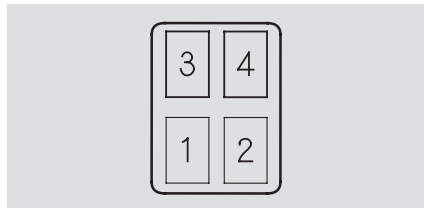

No.	Amps.	Circuits Protected
1	40 A	ABS Motor
2	20 A	ABS F/S
3	20 A	Rear ACC Socket
4	20 A	4WD



## INTERIOR FUSE BOX Driver's Side

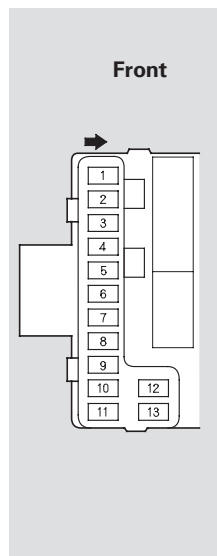

No.	Amps.	Circuits Protected
1	15 A	Fuel Pump
2	10 A	SRS
3	7.5 A	Heater Control, A/C Clutch Relay, Cooling Fan Relay
4	7.5 A	Power Mirror, VTM-4
5	7.5 A	Daytime Running Light*
6	15 A	ECU (PCM), Cruise Control
7	7.5 A	OPDS, Rear Wiper
8	7.5 A	ACC Relay
9	10 A	Back-up Lights, Instrument Lights
10	7.5 A	Turn Signals
11	15 A	IG Coil
12	30 A	Front Wiper
13	7.5 A	Starter Signal

\* : On Canadian models

## Passenger's Side

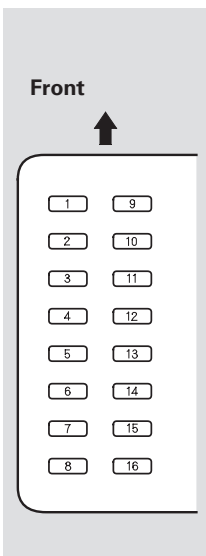

No.	Amps.	Circuits Protected
1	20 A	Driver's Power Window
2	20 A	Driver's Power Seat Reclining
3	20 A	Heated Seat*
4	20 A	Driver's Power Seat Sliding
5	—	Not used
6	10 A	Daytime Running Light*
7	20 A	Driver's side Rear Power Window
8	20 A	Front Passenger's Power Window
9	15 A	Front Accessory Socket, Radio
10	15 A	Small Light
11	10 A	Interior Light, Navi
12	20 A	Power Door Lock
13	7.5 A	Back Up
14	—	Not used
15	—	Not used
16	20 A	Passenger's Side Rear Power Window

\* : Canadian models



The diagrams in this section give you the dimensions and capacities of your Honda, and the locations of the identification numbers. It also includes information you should know about your vehicle's tires and emissions control systems.

Identification Numbers.....	216	Emissions Controls.....	223
Specifications .....	218	The Clean Air Act.....	223
DOT Tire Quality Grading .....	220	Crankcase Emissions Control System.....	223
Uniform Tire Quality Grading .....	220	Evaporative Emissions Control System.....	223
Treadwear .....	220	Onboard Refueling Vapor Recovery .....	223
Traction.....	220	Exhaust Emissions Controls ...	224
Temperature .....	221	PGM-FI System .....	224
		Ignition Timing Control System.....	224
		Exhaust Gas Recirculation (EGR) System.....	224
		Three Way Catalytic Converter.....	224
		Replacement Parts.....	224
		Three Way Catalytic Converter...	225
		State Emissions Testing .....	226
		Testing of Readiness Codes....	226

## Identification Numbers

---

Your vehicle has several identifying numbers in various places.

The Vehicle Identification Number (VIN) is the 17-digit number your Honda dealer uses to register your vehicle for warranty purposes. It is also necessary for licensing and insuring your vehicle. The easiest place to find the VIN is on a plate fastened to the top of the dashboard. You can see it by looking through the windshield on the driver's side. It is also on the Certification label attached to the driver's doorjamb, and is stamped on the engine compartment bulkhead. The VIN is also provided in bar code on the Certification label.

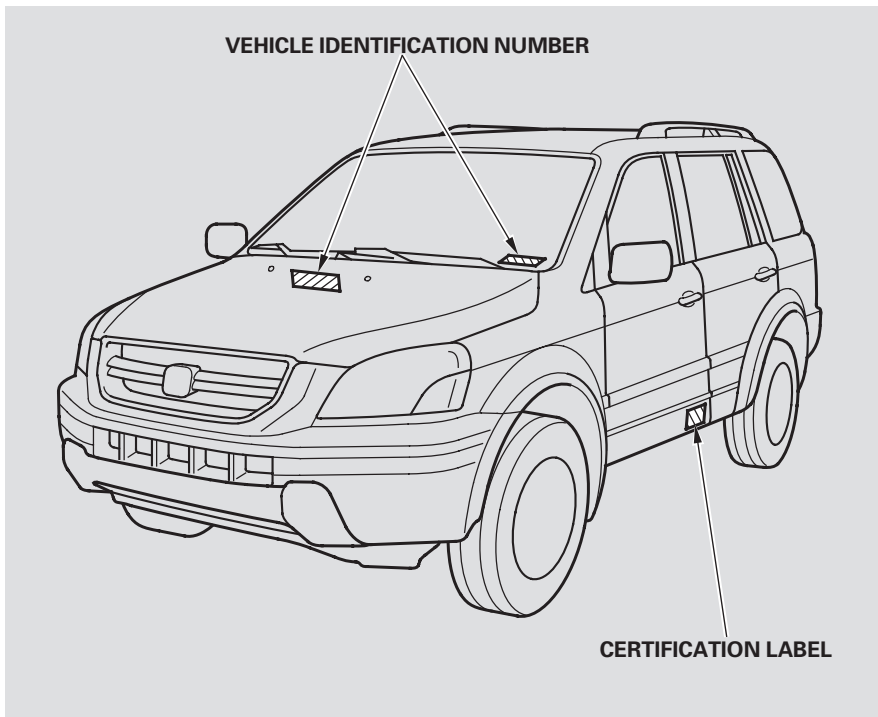

The Engine Number is stamped into the engine block. It is on the front.

The Transmission Number is on a label on top of the transmission.

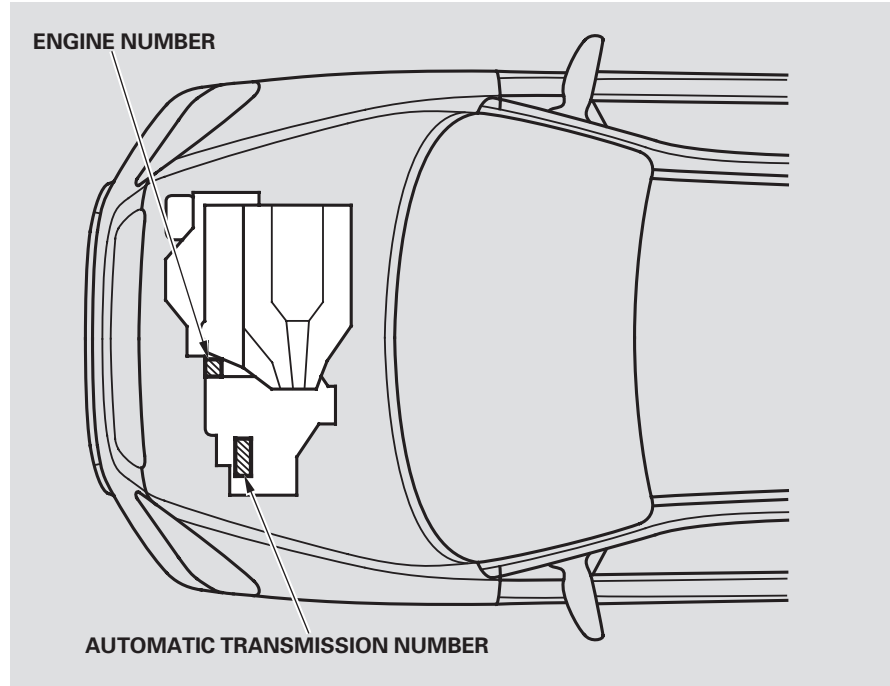

# Specifications

## Dimensions

Length	188.0 in (4,775 mm)
Width	76.3 in (1,938 mm)
Height	70.6 in (1,793 mm)
Wheelbase	106.3 in (2,700 mm)
Track	Front 66.3 in (1,685 mm)
	Rear 66.5 in (1,690 mm)

## Weights

Gross vehicle weight rating	See the tire information label attached to the driver's doorjamb.
Gross combined weight** <sup>2</sup> rating (GCWR)	9,700 lbs (4,400 kg)* <sup>1</sup>

\* 1 : Equipped with transmission fluid cooler and power steering fluid cooler.

\* 2 : The GCWR must be reduced 2 percent for every 1,000 feet (305 meters) of elevation.

## Air Conditionig

Refrigerant type	HFC-134a (R-134a)
Charge quantity	24.7 – 26.5 oz (700 – 750 g)
Lubricant type	ND-OIL8

## Capacities

Fuel tank		Approx. 19.3 US gal (73 ℓ)
Engine coolant	Change* <sup>1</sup> Total	1.74 US gal (6.6 ℓ) 2.25 US gal (8.5 ℓ)
Engine oil	Change* <sup>2</sup> Including filter Without filter Total	5.1 US qt (4.8 ℓ) 4.5 US qt (4.3 ℓ) 5.8 US qt (5.5 ℓ)
Automatic transmission fluid	Change Total	3.2 US qt (3.0 ℓ) 8.2 US qt (7.8 ℓ)
Rear differential fluid	Change	2.79 US qt (2.64 ℓ)
Windshield washer reservoir		4.8 US qt (4.5 ℓ)

\* 1 : Including the coolant in the reserve tank and that remaining in the engine.

Reserve tank capacity:  
0.16 US gal (0.6 ℓ)

\* 2 : Excluding the oil remaining in the engine.

# Specifications

## Lights

Headlights	12 V – 60 W/55 W	(HB2)
Front side marker lights	12 V – 5 W	(168)
Front turn signal lights/ Parking lights	12 V – 27 W/8 W	(1157 NA)
Rear side marker lights	12 V – 5 W	(168)
Rear turn signal/hazard lights	12 V – 21 W/5 W	(7443)
Stop/Taillights	12 V – 21 W/5 W	(7443)
Backup lights	12 V – 21 CP (18 W)	(921)
License plate lights	12 V – 5 W	(168)
High-mount brake light	12 V – 18 W	(921)
Individual map lights	12 V – 6.2 W	(204)
Tailgate light	12 V – 5 W	
Vanity mirror light	12 V – 1.1 W	
Door (Courtesy) light	12 V – 3.8 W	
Grabrail lights	12 V – 12.4 W	
Console lights	14 V – 1.4 W	

## Battery

Capacity	12 V – 65 AH/20 HR
----------	--------------------

## Fuses

Interior	Driver's side	See page 213 or the fuse label attached to the dashboard.
	Passenger's side	See page 213 or the fuse label attached to the inside of the fuse box door under the dashboard.
Under-hood		See page 212 or the fuse box cover.

## Engine

Type	Water cooled 4-stroke SOHC, V6 gasoline engine	
Bore x Stroke	3.50 x 3.66 in (89.0 x 93.0 mm)	
Displacement	211.8 cu-in (3,471 cm <sup>3</sup> )	
Compression ratio	10.0 : 1	
Spark plugs	NGK:	PZFR5F-11
	DENSO:	PKJ16CR-L11

## Alignment

Toe-in	Front	0.00 in (0.0 mm)
	Rear	0.00 in (0.0 mm)
Camber	Front	–0°50'
	Rear	–0°50'
Caster	Front	1°88'

## Tires

Size	Front/Rear	P235/70R16 104S
	Spare	T155/90D16 110M
Pressure	Front/Rear	32 psi (220 kPa , 2.2 kgf/cm <sup>2</sup> )
	Spare	60 psi (420 kPa , 4.2 kgf/cm <sup>2</sup> )

## DOT Tire Quality Grading (U.S. Vehicles)

---

The tires on your car meet all U.S. Federal Safety Requirements. All tires are also graded for treadwear, traction, and temperature performance according to Department of Transportation (DOT) standards. The following explains these gradings.

### **Uniform Tire Quality Grading**

Quality grades can be found where applicable on the tire sidewall between the tread shoulder and the maximum section width. For example:

**Treadwear 200**

**Traction AA**

**Temperature A**

All passenger vehicle tires must conform to Federal Safety Requirements in addition to these grades.

### **Treadwear**

The treadwear grade is a comparative rating based on the wear rate of the tire when tested under controlled conditions on a specified government test course. For example, a tire graded 150 would wear one and one-half (1 1/2) times as well on the government course as a tire graded 100. The relative performance of tires depends upon the actual conditions of their use, however, and may depart significantly from the norm due to variations in driving habits, service practices and differences in road characteristics and climate.

### **Traction — AA, A, B, C**

The traction grades, from highest to lowest, are AA, A, B, and C. Those grades represent the tire's ability to stop on wet pavement as measured under controlled conditions on specified government test surfaces of asphalt and concrete. A tire marked C may have poor traction performance.

Warning: The traction grade assigned to this tire is based on straight-ahead braking traction tests, and does not include acceleration, cornering, hydroplaning, or peak traction characteristics.



## DOT Tire Quality Grading (U.S. Vehicles), Tire Labeling

### Temperature – A, B, C

The temperature grades are A (the highest), B, and C, representing the tire's resistance to the generation of heat and its ability to dissipate heat when tested under controlled conditions on a specified indoor laboratory test wheel. Sustained high temperature can cause the material of the tire to degenerate and reduce tire life, and excessive temperature can lead to sudden tire failure. The grade C corresponds to a level of performance, which all passenger vehicle tires must meet under the Federal Motor Vehicle Safety Standard No. 109. Grades B and A represent higher levels of performance on the laboratory test wheel than the minimum required by law.

Warning: The temperature grade for this tire is established for a tire that is properly inflated and not overloaded. Excessive speed, underinflation, or excessive loading, either separately or in combination, can cause heat buildup and possible tire failure.

### Tire Labeling

The tires that came on your vehicle have a number of markings. Those you should be aware of are described below.

### Tire Size

Whenever tires are replaced, they should be replaced with tires of the same size. Following is an example of tire size with an explanation of what each component means.

P225/55R16 94V

- P – Vehicle type (P indicates passenger vehicle).
- 225 – Tire width in millimeters.
- 55 – Aspect ratio (the tire's section height as a percentage of its width).
- R – Rim diameter in inches.
- 16 – Load index (a numerical code associated with the maximum load the tire can carry).
- 94 – Tire construction code (R indicates radial).
- V – Speed symbol (an alphabetical code indicating the maximum speed rating).

## Tire Labeling

---

### *Tire Identification Number*

Tire Identification Number (TIN) is a group of numbers and letters that look like the following example TIN.

DOT B97R FW6X 2202

DOT – This indicates that the tire meets all requirements of the U.S. Department of Transportation.

B97R – Manufacturer's identification mark.

FW6X – Tire type code.

2202 – Date of manufacture.

The burning of gasoline in your vehicle's engine produces several by-products. Some of these are carbon monoxide (CO), oxides of nitrogen (NOx) and hydrocarbons (HC). Gasoline evaporating from the tank also produces hydrocarbons. Controlling the production of NOx, CO, and HC is important to the environment. Under certain conditions of sunlight and climate, NOx and HC react to form photochemical "smog." Carbon monoxide does not contribute to smog creation, but it is a poisonous gas.

### **The Clean Air Act**

The United States Clean Air Act\* sets standards for automobile emissions. It also requires that automobile manufacturers explain to owners how their emissions controls work and what to do to maintain them. This section summarizes how the emissions controls work. Scheduled maintenance is on page 164 .

\* In Canada, Honda vehicles comply with the Canadian emission requirements, as specified in an agreement with Environment Canada, at the time they are manufactured.

### **Crankcase Emissions Control System**

Your vehicle has a Positive Crankcase Ventilation System. This keeps gasses that build up in the engine's crankcase from going into the atmosphere. The Positive Crank-

case Ventilation valve routes them from the crankcase back to the intake manifold. They are then drawn into the engine and burned.

### **Evaporative Emissions Control System**

As gasoline evaporates in the fuel tank, an evaporative emissions control canister filled with charcoal adsorbs the vapor. It is stored in this canister while the engine is off. After the engine is started and warmed up, the vapor is drawn into the engine and burned during driving.

### **Onboard Refueling Vapor Recovery**

The Onboard Refueling Vapor Recovery (ORVR) system captures the fuel vapors during refueling. The vapors are adsorbed in a canister filled with activated carbon. While driving, the fuel vapors are drawn into the engine and burned off.

## Emissions Controls

---

### **Exhaust Emissions Controls**

The exhaust emissions controls include four systems: PGM-FI, Ignition Timing Control, Exhaust Gas Recirculation and Three Way Catalytic Converter. These four systems work together to control the engine's combustion and minimize the amount of HC, CO, and NO<sub>x</sub> that comes out the tailpipe. The exhaust emissions control systems are separate from the crankcase and evaporative emissions control systems.

#### ***PGM-FI System***

The PGM-FI System uses sequential multiport fuel injection. It has three subsystems: Air Intake, Engine Control, and Fuel Control. The Powertrain Control Module (PCM) uses various sensors to determine how much air is going into the engine. It then controls how much fuel to inject under all operating conditions.

#### ***Ignition Timing Control System***

This system constantly adjusts the ignition timing, reducing the amount of HC, CO, and NO<sub>x</sub> produced.

#### ***Exhaust Gas Recirculation (EGR) System***

The Exhaust Gas Recirculation (EGR) system takes some of the exhaust gas and routes it back into the intake manifold. Adding exhaust gas to the air/fuel mixture reduces the amount of NO<sub>x</sub> produced when the fuel is burned.

#### ***Three Way Catalytic Converter***

The three way catalytic converter is in the exhaust system. Through chemical reactions, it converts HC, CO, and NO<sub>x</sub> in the engine's exhaust to carbon dioxide (CO<sub>2</sub>), dinitrogen (N<sub>2</sub>), and water vapor.

### **Replacement Parts**

The emissions control systems are designed and certified to work together in reducing emissions to levels that comply with the Clean Air Act. To make sure the emissions remain low, you should use only new Honda replacement parts or their equivalent for repairs. Using lower quality parts may increase the emissions from your vehicle.

The emissions control systems are covered by warranties separate from the rest of your vehicle. Read your warranty manual for more information.

## Three Way Catalytic Converter

The three way catalytic converter contains precious metals that serve as catalysts, promoting chemical reactions to convert the exhaust gasses without affecting the metals. The catalytic converter is referred to as a three-way catalyst, since it acts on HC, CO, and NOx. A replacement unit must be an original Honda part or its equivalent.

The three way catalytic converter must operate at a high temperature for the chemical reactions to take place. It can set on fire any combustible materials that come near it. Park your vehicle away from high grass, dry leaves, or other flammables.

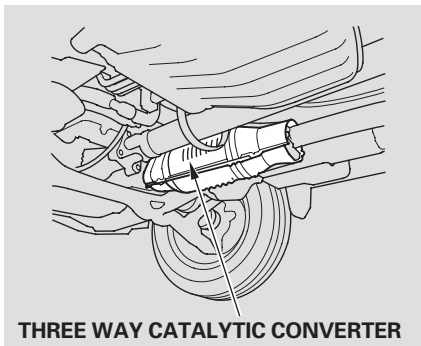

**THREE WAY CATALYTIC CONVERTER**

A defective three way catalytic converter contributes to air pollution, and can impair your engine's performance. Follow these guidelines to protect your vehicle's three way catalytic converter.

- Always use unleaded gasoline. Even a small amount of leaded gasoline can contaminate the catalyst metals, making the three way catalytic converter ineffective.

- Keep the engine tuned-up.
- Have your vehicle diagnosed and repaired if it is misfiring, back-firing, stalling, or otherwise not running properly.

## State Emissions Testing

---

### Testing of Readiness Codes

If you take your vehicle for a state emissions test shortly after the battery has been disconnected or gone dead, it may not pass the test. This is because of certain “readiness codes” that must be set in the on-board diagnostics for the emissions systems. These codes are erased when the battery is disconnected, and set again only after several days of driving under a variety of conditions.

If the testing facility determines that the readiness codes are not set, you will be requested to return at a later date to complete the test. If you must get the vehicle re-tested within the next two or three days, you can condition the vehicle for re-testing by doing the following.

- Make sure the gas tank is nearly, but not completely, full (around 3/4).
- Make sure the vehicle has been parked with the engine off for 8 hours or more.
- Make sure the ambient temperature is between 20° and 95° F.
- Without touching the accelerator pedal, start the engine, and let it idle for 20 seconds.
- Keep the vehicle in Park. Increase the engine speed to 2,000 rpm and hold it there until the temperature gauge rises to at least 1/4 of the scale (approximately 3 minutes).
- Select a nearby lightly traveled major highway where you can maintain a speed of 50 to 60 mph (80 to 97 km/h) for at least 20 minutes. Drive on the highway in D. Do not use the cruise control. When traffic allows, drive for 90 seconds without moving the accelerator pedal. (Vehicle speed may vary slightly; this is okay.) If you cannot do this for a continuous 90 seconds because of traffic conditions, drive for at least 30 seconds, then repeat it two more times (for a total of 90 seconds).

- Then drive in city/suburban traffic for at least 10 minutes. When traffic conditions allow, let the vehicle coast for several seconds without using the accelerator pedal or the brake pedal.

If the testing facility determines the readiness codes are still not set, see your Honda dealer.





## Warranty and Customer Relations

---

Customer Service Information.....	230
Warranty Coverages .....	231
Reporting Safety Defects (U.S. Vehicles) .....	232
Authorized Manuals.....	233

## Customer Service Information

---

Honda dealership personnel are trained professionals. They should be able to answer all your questions. If you encounter a problem that your dealership does not solve to your satisfaction, please discuss it with the dealership's management. The Service Manager or General Manager can help. Almost all problems are solved in this way.

If you are dissatisfied with the decision made by the dealership's management, contact your Honda Customer Service Office.

U.S. Owners:  
American Honda Motor Co.  
Honda Customer Service  
Mail Stop 500-2N-7D  
1919 Torrance Boulevard  
Torrance, California 90501-2746

Tel: (800) 999-1009

Canadian Owners:  
**CUSTOMER RELATIONS**  
**RELATIONS AVEC LA CLIENTÉLE**

Honda Canada Inc.  
715 Milner Avenue  
Toronto, ON  
M1B 2K8

Tel: 1-888-9-HONDA-9  
Fax: Toll-free 1-877-939-0909  
Toronto (416) 287-4776

In Puerto Rico and the U.S. Virgin Islands:

Bella International  
P.O. Box 190816  
San Juan, Puerto Rico 00919-0816

(787) 250-4318

When you call or write, please give us this information:

- Vehicle Identification Number (see page 216 )
- Name and address of the dealer who services your vehicle
- Date of purchase
- Mileage on your vehicle
- Your name, address, and telephone number
- A detailed description of the problem
- Name of the dealer who sold the vehicle to you

### **U.S. Owners**

Your new Honda is covered by these warranties:

***New Vehicle Limited Warranty*** – covers your new vehicle, except for the battery, emissions control systems, and accessories, against defects in materials and workmanship.

***Emissions Control Systems Defects Warranty and Emissions Performance Warranty*** – these two warranties cover your vehicle's emissions control systems. Time, mileage, and coverage are conditional. Please read the warranty manual for exact information.

***Original Equipment Battery Limited Warranty*** – this warranty gives up to 100 percent credit toward a replacement battery.

***Seat Belt Limited Warranty*** – a seat belt that fails to function properly is covered for the useful life of the vehicle.

***Rust Perforation Limited Warranty*** – all exterior body panels are covered for rust-through from the inside for the specified time period with no mileage limit.

***Accessory Limited Warranty*** – Honda Accessories are covered under this warranty. Time and mileage limits depend on the type of accessory and other factors. Please read your warranty manual for details.

***Replacement Parts Limited Warranty*** – covers all genuine Honda replacement parts against defects in materials and workmanship.

***Replacement Battery Limited Warranty*** – provides prorated coverage for a replacement battery purchased from a Honda dealer.

***Replacement Muffler Lifetime Limited Warranty*** – provides coverage for as long as the purchaser of the muffler owns the vehicle.

Restrictions and exclusions apply to all these warranties. Please read the 2004 Honda Warranty Information booklet that came with your vehicle for precise information on warranty coverages. Your Honda's original tires are covered by their manufacturer. Tire warranty information is in a separate booklet.

### **Canadian Owners**

Please refer to the 2004 Warranty Manual that came with your vehicle.

## Reporting Safety Defects (U.S. Vehicles)

---

If you believe that your vehicle has a defect which could cause a crash or could cause injury or death, you should immediately inform the National Highway Traffic Safety Administration (NHTSA) in addition to notifying American Honda Motor Co., Inc.

If NHTSA receives similar complaints, it may open an investigation, and if it finds that a safety defect exists in a group of vehicles, it may order a recall and remedy campaign. However, NHTSA cannot become involved in individual problems between you, your dealer, or American Honda Motor Co., Inc.

To contact NHTSA, you may either call the Auto Safety Hotline toll-free at 1-800-424-9393 (or 366-0123 in Washington D.C. area) or write to: NHTSA, U.S. Department of Transportation, Washington, D.C. 20590. You can also obtain other information about motor vehicle safety from the Hotline.

## Purchasing Factory Authorized Manuals (U.S. only)

The publications shown below can be purchased from Helm Incorporated. You can order in any of three ways:

- Detach and mail the order form on the right half of this page
- Call Helm Inc. at 1-800-782-4356 (credit card orders only)
- Go online at [www.helminc.com](http://www.helminc.com)

If you are interested in other years or models, contact Helm Inc. at 1-800-782-4356

Publication Form Number	Form Description	Price Each*
61S9V01	2004 Honda Pilot Service Manual	\$70.00
61S9V01EL	2004 Honda Pilot Electrical Troubleshooting Manual	\$50.00
61S9V30	2004 Honda Pilot Body Repair Manual	\$44.00
31S9V610	2004 Honda Pilot Owner's Manual	\$34.00
31S9V710	2004 Honda Pilot Navigation System Owner's Manual	\$29.00
31S9VQ10	2004 Honda Pilot Quick Start Guide	\$12.00
HON-R	Order Form for Previous Years- Indicate Year and Model Desired	FREE
* Prices are subject to change without notice and without incurring obligation.		

*Valid only for sales within the U.S. Canadian owners should contact their authorized Honda dealer.*

**ORDER TOLL FREE: 1-800-782-4356**

**(NOTE: For Credit Card Holder Orders Only)**

Monday-Friday 8:00 A.M. — 6:00 P.M. EST

**MINIMUM CREDIT CARD PURCHASE \$10.00**

**OR**

By completing this form you can order the materials desired. You can pay by check or money order, or charge to your credit card. Mail to Helm Incorporated at the address shown on the back of the order form.

2004 HON	PUBLICATION NUMBER	VEHICLE MODEL		Qty	Price Each*	Total Price
		Name	Year			
* Prices are subject to change without notice and without incurring obligation.					TOTAL MATERIAL	
					Mich. Purchases Add 6% Sales Tax	
Orders are mailed within 10 days. Please allow adequate time for delivery.					HANDLING CHARGE	\$6.00
					GRAND TOTAL	

## Authorized Manuals

SHIP TO	NOTE: Dealers and Companies please provide dealer or company name, and also the name of the person to whose attention the shipment should be sent. For purchases outside U.S.A. please write to the address shown below for a quotation.	
	_____ Customer Name	_____ Attention
	_____ Street Address -- No P.O. Box Number	_____ Apartment Number
	_____ City	_____ State & Zip Code
	_____ Daytime Telephone Number (      )	

PAYMENT	<input type="checkbox"/> Check or money order enclosed payable to Helm Inc -- U.S. funds only. Do not send cash	
	<input type="checkbox"/> Master Card	<input type="checkbox"/> VISA <input type="checkbox"/> Check here if your billing address is different from the shipping address shown above.
	Account Number	Expiration: Mo. Yr.
	<input type="text"/>	<input type="text"/> - <input type="text"/>
	_____ CUSTOMER SIGNATURE    DATE	

These Publications cannot be returned for credit without receiving advance authorization within 14 days of delivery. On returns, a restocking fee may be applied against the original order.

**HELM** P.O. BOX 07280-DETROIT, MICHIGAN 48207-1-800-782-4356

### Service Manual:

This manual covers maintenance and recommended procedures for repair to engine and chassis components. It is written for the journeyman mechanic, but is simple enough for most mechanically-inclined owners to understand.

### Electrical Troubleshooting Manual:

This manual complements the Service Manual by providing in-depth troubleshooting information for each electrical circuit in your vehicle.

### Body Repair Manual:

This manual describes the procedures involved in the replacement of damaged body parts.

## A

Accessories and Modifications ....	129
ACCESSORY (Ignition Key Position) .....	64
Accessory Power Sockets.....	77
Additives, Engine Oil.....	172
Airbag (SRS) .....	9, 19
Airbags, Additional Information.....	19
Additional Safety Precautions....	24
Airbag Service.....	24
How the Side Airbag Off Indicator Works.....	23
How the SRS Indicator Works...	23
How Your Front Airbags Work.....	20
How Your Side Airbags Work....	22
SRS Components .....	19
Air Conditioning System.....	82
Rear A/C Control .....	87
Air Pressure, Tires .....	188
Antifreeze .....	174
Anti-lock Brakes (ABS) Indicator Light .....	49, 146
Operation.....	145
Anti-theft, Audio System.....	102

Anti-theft Steering Column Lock ..	64
Audio System .....	88
Automatic Seat Belt Tensioners....	18
Automatic Lighting Off Feature....	58
Automatic Speed Control.....	116
Automatic Transmission.....	138
Capacity, Fluid .....	218
Checking Fluid Level.....	176
Shifting.....	138
Shift Lever Position Indicator ..	138
Shift Lever Positions .....	139
Shift Lock Release.....	141

## B

Battery	
Charging System	
Indicator.....	48, 206
Jump Starting .....	202
Maintenance.....	193
Specifications .....	219
Before Driving .....	123
Belts, Seat .....	8, 16
Beverage Holders.....	77
Booster Seats .....	39

## Brakes

Anti-lock System (ABS).....	145
Break-in, New Linings .....	124
Fluid .....	178
Bulb Replacement .....	182
Parking.....	75
System Indicator.....	49, 208
Wear Indicators .....	145
Braking System.....	144
Break-in, New Vehicle .....	124
Brightness Control, Instruments...	59
Brights, Headlights .....	58
Bulb Replacement	
Brake Lights.....	182
Front Parking Lights.....	181
Front Side Marker Lights.....	183
Headlights .....	180
High-mount Brake Lights.....	182
Rear Bulbs .....	182
Specifications .....	219
Turn Signal Light .....	181, 182
Bulbs, Halogen.....	180

CONTINUED

# Index

---

## C

Cancel Button.....	117
Capacities Chart.....	218
Carbon Monoxide Hazard .....	42
Cargo, <i>how to carry</i> .....	131
Cassette Player	
Care .....	95
Operation .....	98
CAUTION, Explanation of .....	ii
CD Care .....	95
CD Changer.....	94
CD Changer Error Message .....	97
CD Player.....	93
CD Player Error Message .....	96
Certification Label.....	216
Chains, <i>tires</i> .....	192
Changing a Flat Tire .....	197
Change Oil	
How to .....	172
When to .....	164, 165
Charging System Indicator ....	48, 206
Checklist, Before Driving.....	136
Childproof Door Locks .....	65
Child Safety .....	25
Booster Seats .....	39

Child Seats.....	30
Important Safety Reminders.....	25
Infants .....	29
Larger Children .....	38
LATCH.....	33
Risks with Airbags.....	26
Small Children.....	30
Tethers.....	37
Where Should a Child Sit?.....	26
Child Seats	
LATCH.....	33
Lower Anchors .....	33
Tether Anchorage Points .....	37
Climate Control System.....	86
Clock, Setting the .....	103
Clock .....	103
Code, Audio System .....	102
CO in the Exhaust .....	223
Cold Weather, Starting in.....	137
Compact Spare <i>tire</i> .....	196
Console Compartment .....	77
Consumer Information* .....	230
Controls, Instruments and.....	45
Coolant	
Adding.....	174
Checking.....	127

Proper Solution .....	174
Temperature Gauge.....	55
Crankcase Emissions Control	
System.....	223
Cruise Control Indicator .....	51
Cruise Control Operation .....	116
Cup Holders.....	77
Customer Service Information.....	230

## D

DANGER, Explanation of .....	ii
Dashboard .....	2, 46
Daytime Running Lights.....	59
Daytime Running Lights	
Indicator .....	51
Dead Battery .....	202
Defects, Reporting Safety.....	232
Defogger, Rear Window .....	60
Defrosting the Windows.....	83, 85
Dimensions.....	218
Dimming the Headlights .....	58
Dipstick	
Automatic Transmission.....	176
Engine Oil.....	127
Directional Signals.....	58



Disc Brake Wear Indicators.....	145
Disposal of Used Oil.....	173
Doors	
Locking and Unlocking.....	65
Lockout Prevention.....	65
Power Door Locks.....	65
DOT Tire Quality Grading.....	220
Driver and Passenger Safety.....	5
Driving.....	135
Economy.....	128
DVD Player.....	104
DVD Player Error Message.....	112

## E

Economy, Fuel.....	128
Emergencies	
Jump Starting.....	202
Towing.....	208
Hazard Warning <i>Button</i> .....	59
Emergencies on the Road.....	195
Battery, Jump Starting.....	202
Brake System Indicator.....	208
Changing a Flat Tire.....	197
Charging System Indicator.....	206
Checking the Fuses.....	210

Low Oil Pressure Indicator.....	206
Malfunction Indicator Lamp.....	207
Overheated Engine.....	204
Emergency Brake.....	75
Emergency Flashers.....	59
Emergency Towing.....	208
Emissions Controls.....	223
Emissions Testing, State.....	226
Engine	
Coolant Temperature Gauge.....	55
<i>If it won't start</i> .....	137
Malfunction Indicator	
Lamp.....	48, 207
Oil Pressure Indicator.....	48, 206
Oil, What Kind to Use.....	171
Overheating.....	204
Specifications.....	219
Speed Limiter.....	140
Starting.....	137
Evaporative Emissions Controls.....	223
Exhaust Fumes.....	42
Exhaust Gas Recirculation	
System.....	224
Expectant Mothers, Use of Seat	
Belts by.....	15

## F

Fan, Interior.....	82
Features, Comfort and	
Convenience.....	81
Filling the Fuel Tank.....	125
Filters	
Oil.....	172
Flashers, Hazard Warning.....	59
Flat Tire, Changing a.....	197
Fluids	
Automatic Transmission.....	176
Brake.....	178
Power Steering.....	179
Windshield Washer.....	175
FM Stereo Radio	
Reception.....	91
Folding the Third Seat.....	71
Four-way Flashers.....	59
Front Airbags.....	10, 19
Front Seat	
Adjusting.....	68, 69
Heaters.....	67
Airbags.....	9, 19

CONTINUED

# Index

---

Fuel.....	124
Fill Door and Cap.....	125
Gauge .....	54
Octane Requirement .....	124
Reserve Indicator.....	51
Tank, Filling the.....	125
Fuses, Checking the.....	210

## G

Gas Mileage, Improving.....	128
Gasoline .....	124
Fuel Reserve Indicator .....	51
Gauge .....	54
Octane Requirement .....	124
Tank, Filling the.....	125
Gas Station Procedures.....	125
Gauges	
Engine Coolant Temperature ...	55
Fuel.....	54
GAWR (Gross Axle Weight Rating) .....	148
GCWR (Gross Combined Weight Rating) .....	148
Gearshift Lever Positions.....	139
Glove Box .....	78

GVWR (Gross Vehicle Weight Rating) .....	148
---	-----

## H

Halogen Headlight Bulbs.....	180
Hazard Warning Button.....	59
Headlights.....	58
Aiming.....	180
Automatic Lighting Off.....	58
Daytime Running Lights.....	59
High Beam Indicator .....	51
High Beams, Turning on .....	58
Low Beams, Turning on .....	58
Reminder Chime.....	58
Replacing Halogen Bulbs .....	180
Turning on.....	58
Headphones.....	113
Head Restraints .....	72
Heated Mirror .....	74
Heater, Seat .....	67
Heating and Cooling.....	82
High Altitude, Starting at.....	137
High-Low Beam Switch .....	58
High-mount Brake Light.....	182

HomeLink Universal Transceiver.....	118
Hood, Opening the .....	126
Horn.....	56

## I

Identification Number, Vehicle....	216
Ignition	
Keys.....	62
Switch.....	64
Timing Control System.....	224
Immobilizer System.....	62
Important Safety Precautions .....	6
Indicators	
A/T Temperature.....	52
ABS (Anti-lock Brake) .....	49
Brake (Parking and Brake System) .....	49
Brake Lamp.....	50
Charging System .....	48
Cruise Control.....	51
DRL (Daytime Running Lights).....	51
High Beam.....	51
Key (Immobilizer System) .....	49

Low Fuel .....	51
Low Oil Pressure .....	48
Side Airbag Off .....	48
SRS .....	48
Turn Signal and Hazard Warning .....	50
VTM-4 .....	52
Washer Level .....	51
Indicators, Instrument Panel.....	47
Infant Restraint.....	26, 29
Infant Seats.....	26, 29
Inflation, Proper Tire .....	188
Inside Mirror .....	74
Inspection, Tire .....	189
Instrument Panel .....	2, 46
Instrument Panel Brightness.....	59
Introduction.....	i

## J

Jacking up the Vehicle .....	198
Jack, Tire .....	197
Jump Starting .....	202

## K

Keys.....	62
-----------	----

## L

Label, Certification .....	216
Lane Change, Signaling .....	58
Lap/Shoulder Belts.....	12, 17
LATCH Anchorage System.....	33
Light .....	79
Lights .....	180
Bulb Replacement .....	180
Indicator.....	47
Parking.....	58
Turn Signal.....	58
Load Limits.....	132
LOCK (Ignition Key Position) .....	64
Locks	
Anti-theft Steering Column .....	64
Fuel Fill Door .....	125
Glove Box .....	78
Lockout Prevention .....	65
Power Door .....	65
Low Coolant Level.....	127
Low Fuel Indicator .....	51

Low Oil Pressure Indicator ....	48, 206
Lower Anchor .....	33
Lubricant Specifications Chart ...	218
Luggage, <i>Storing (Cargo)</i> .....	131

## M

Maintenance.....	159
Owner's Maintenance	
Checks .....	163
Record.....	167-169
Required Indicator.....	53
Safety.....	160
Schedule .....	164-166
Malfunction Indicator Lamp ..	48, 207
Manual Seat Adjustments.....	69
Meters, Gauges.....	54
Modifications.....	130

## N

Neutral Gear Position.....	139
New Vehicle Break-in .....	124
NOTICE, Explanation of.....	i
Numbers, Identification.....	216

CONTINUED

# Index

---

## O

- Octane Requirement, Gasoline .... 124
- Odometer ..... 54
- Odometer, Trip ..... 54
- Off-Highway Driving ..... 155
- Off-Road Precautions ..... 155
- Oil
  - Change, How to ..... 172
  - Change, When to ..... 164, 165
  - Checking Engine ..... 127
  - Pressure Indicator ..... 48, 206
  - Selecting Proper Viscosity
    - Chart ..... 171
- ON (Ignition Key Position) ..... 64
- Onboard Refueling Vapor
  - Recovery ..... 223
- Outside Mirrors ..... 74
- Overheating, Engine ..... 204
- Owner's Maintenance Checks ..... 163

## P

- Panel Brightness Control ..... 59
- Park Gear Position..... 139

- Parking ..... 143
- Parking Brake ..... 75
- Parking Brake and Brake System
  - Indicator ..... 49, 208
- Parking Lights ..... 58
- Parking Over Things that Burn... 225
- Playing the Radio ..... 88
- Playing a CD ..... 93
- Playing a CD Changer ..... 94
- Playing a Tape ..... 98
- PGM-FI System..... 224
- Power Door Locks..... 65
- Power Seat Adjustments..... 68
- Power Socket Locations..... 76
- Power Windows ..... 73
- Pregnancy, Using Seat Belts ..... 15
- Protecting Adults and Teens..... 10
  - Additional Safety Precautions.... 16
  - Advice for Pregnant Women..... 15
- Protecting Children ..... 25
  - General Guidelines ..... 25
- Protecting Infants ..... 29
- Protecting Larger Children ..... 38
- Protecting Small Children ..... 30

## R

- Radiator Overheating..... 204
- Radio/CD Sound
  - System..... 88
- Readiness Codes ..... 226
- Rear A/C Unit ..... 87
- Rear Audio Control Panel..... 107
- Rear Entertainment System..... 104
- Rear Lights, Bulb Replacement... 182
- Rear View Mirror..... 74
- Rear Window Defogger ..... 60
- Rear Window Wiper and Washer.. 57
- Reclining the Seat Backs ..... 68, 69
- Reclining the Second Seats ..... 70
- Reclining the Third Seat ..... 71
- Reminder Lights ..... 47
- Remote Audio Controls..... 101
- Remote Control (RES) ..... 109
- Remote Transmitter ..... 66
- Replacement Information
  - Dust and Pollen Filter ..... 185
  - Engine Oil and Filter ..... 172
  - Floor Mats ..... 185
  - Fuses ..... 210
  - Light Bulbs ..... 180

- Schedule ..... 164-166
- Seat Belts ..... 184
- Timing Belt ..... 177
- Tires ..... 191
- Wiper Blades ..... 186
- Replacing Seat Belts After a  
Crash ..... 19
- Reserve Tank, Engine Coolant .... 127
- Restraint, Child ..... 25
- Reverse Gear Position ..... 139
- Roof Rack ..... 131
- Rotation, Tire ..... 190
- S**
- Safety Belts ..... 8, 16
- Safety Defects, Reporting\* ..... 232
- Safety Features ..... 7
- Airbags ..... 9
- Seat Belts ..... 8
- Safety Labels, Location of ..... 43
- Safety Messages ..... ii
- Seat Belts ..... 8, 16
- Additional Information ..... 16
- Automatic Seat Belt  
    Tensioners ..... 18
- Cleaning ..... 185
- Lap/Shoulder Belt ..... 17
- Maintenance ..... 18
- Reminder Light and  
    Beeper ..... 16, 48
- System Components ..... 16
- Use During Pregnancy ..... 15
- Wearing a Lap/Shoulder Belt .... 12
- Seat Heaters ..... 67
- Seats ..... 68
- Folding the Second Seat ..... 70
- Folding the Third Seat ..... 71
- Head Restraints ..... 72
- Reclining the Second Seat ..... 70
- Reclining the Third Seat ..... 71
- Third Seat Access ..... 70
- Seats, Adjusting the ..... 10, 68, 69
- Security System ..... 115
- Serial Number ..... 216
- Service Intervals ..... 161
- Service Manual\* ..... 233
- Service Station Procedures ..... 125
- Setting the Clock ..... 103
- Shifting the Automatic  
Transmission ..... 138
- Shift Lever Position Indicator ..... 138
- Shift Lock Release ..... 141
- Side Marker Lights, Bulb  
Replacement in ..... 183
- Side Airbags ..... 9, 22
- Cutoff Indicator ..... 23, 48
- Signaling Turns ..... 58
- Snow Tires ..... 191
- Sound System ..... 88
- Spare Tire
- Inflating ..... 196
- Specifications ..... 219
- Specifications Charts ..... 218
- Speed Control ..... 116
- SRS, Additional Information ..... 19
- Additional Safety Precautions ... 24
- Airbag Service ..... 24
- How the Side Airbag Off  
    Indicator Works ..... 23
- How the SRS Indicator Works ... 23
- How Your Front Airbags  
    Work ..... 20
- How Your Side Airbags Work ... 22
- SRS Components ..... 19
- SRS Indicator ..... 23, 48

CONTINUED

# Index

---

START (Ignition Key Position) .....	64
Starting the Engine.....	137
In Cold Weather at High Altitude .....	137
With a Dead Battery .....	202
State Emissions Testing .....	226
Steam Coming from Engine .....	204
Steering Wheel	
Adjustment .....	61
Anti-theft Column Lock .....	64
Buttons.....	101, 116
Stereo Sound System .....	88
Storing Your Vehicle .....	194
Sunglasses Holder .....	78
Sun Visor.....	79
Supplemental Restraint System	
Servicing .....	24
SRS Indicator.....	23, 48
System Components.....	19
Synthetic Oil.....	172

## T

Taillights, Changing Bulbs in.....	182
Taking Care of the Unexpected ..	195
Tape Player.....	98

Technical Descriptions	
DOT Tire Quality Grading .....	220
Emissions Control Systems.....	223
State Emissions Testing .....	226
Three Way Catalytic Converter.....	225
Temperature Gauge .....	55
Temperature, Inside Sensor.....	87
Temperature, Outside.....	55
Tensioners, Seat Belts .....	18
Testing of Readiness Codes.....	226
Tether Anchorage Points .....	37
Theft Protection.....	102
Three Way Catalytic Converter..	225
Time, Setting the .....	103
Tilt the Steering Wheel.....	61
Timing Belt.....	177
Tire Chains.....	192
Tire, How to Change a Flat .....	197
Tires .....	188
Air Pressure .....	188
Balancing .....	190
Checking Wear .....	189
Compact Spare .....	196
DOT Tire Quality Grading .....	220
Inflation.....	188

Inspection .....	189
Maintenance.....	190
Replacing .....	191
Rotating.....	190
Snow .....	191
Specifications .....	219
Tire Chains.....	192
Winter Driving .....	191
Tools, Tire Changing .....	197
Towing	
A Trailer.....	147
Emergency Wrecker.....	208
Equipment and Accessories.....	151
Traction Devices.....	192
Your Vehicle Behind a Motorhome.....	154
Weight Limit .....	150
Trailer Loading .....	147
Trailer Towing Tips.....	152
Transmission	
Checking Fluid Level.....	176
Fluid Selection.....	176
Identification Number.....	216
Shifting the Automatic.....	138
Treadwear .....	220
Trip Meter .....	54

Turn Signals ..... 58

## U

Unexpected, Taking Care  
of the ..... 195  
Uniform Tire Quality Grading ..... 220  
Unleaded Gasoline..... 124  
Used Oil, How to Dispose of ..... 173

## V

Vehicle Capacity Load ..... 132  
Vehicle Dimensions..... 218  
Vehicle Identification Number..... 216  
Vehicle Storage ..... 194  
VIN ..... 216  
Viscosity, Oil..... 171  
VTM-4 Lock ..... 142

## W

WARNING, Explanation of ..... ii  
Warning Labels, Location of ..... 43  
Warranty Coverages\* ..... 231

Washer, Windshield  
Checking the Fluid Level ..... 175  
Level Indicator ..... 51  
Operation ..... 57

Wheels  
Adjusting the Steering ..... 61  
Alignment and Balance..... 190  
Compact Spare ..... 196  
Wrench ..... 199

Windows  
Operating the Power ..... 73  
Rear, Defogger ..... 60

Windshield  
Defroster ..... 83, 85  
Washers ..... 57

Wipers, Windshield  
Changing Blades..... 186  
Operation ..... 57  
Rear Window Wiper and  
Washer ..... 57

Worn Tires ..... 189  
Wrecker, Emergency Towing..... 208

\*: U.S. and Canada only

## Service Information Summary

---

### **Gasoline:**

Unleaded gasoline, pump octane number of 86 or higher.

### **Fuel Tank Capacity:**

19.3 US gal (73 ℓ)

### **Recommended Engine Oil:**

API Service SJ "Energy Conserving" oil, SAE 5W-20 viscosity (see page [171](#)).

Oil change capacity (including filter):

5.1 US qt (4.8 ℓ)

### **Automatic Transmission Fluid:**

Honda ATF-Z1 (Automatic Transmission Fluid) preferred, or a DEXRON® III ATF as a temporary replacement (see page [176](#)).

### **Power Steering Fluid:**

Honda Power Steering Fluid preferred, or another brand of power steering fluid as a temporary replacement. Do not use ATF (see page [179](#)).

### **Brake Fluid:**

Honda Heavy Duty Brake Fluid DOT 3 preferred, or a DOT 3 or DOT 4 brake fluid as a temporary replacement (see page [178](#)).

### **Rear Differential Fluid:**

Honda VTM-4 Differential Fluid (see page [177](#)).

### **Tire Pressure (measured cold):**

Front/Rear:

32 psi (220 kPa , 2.2 kgf/cm<sup>2</sup>)

Compact Spare Tire:

60 psi (420 kPa , 4.2 kgf/cm<sup>2</sup>)