

# Contents

The Quick Guide is not intended as a substitute for your *Owner's Manual*. We strongly encourage you to review the *Owner's Manual* and supplementary manuals so you will have a better understanding of your vehicle's capabilities and limitations.

Air Conditioning System (with navigation system)	
Using the automatic mode .....	40
Adjusting the temperature .....	40
To turn off the airflow .....	40
Air Conditioning System (without navigation system)	
Using the automatic mode .....	51
Adjusting the temperature .....	51
To turn off the airflow .....	51
Audio System (with navigation system)	
Audio control screen .....	36
Basic operation .....	36
Radio .....	37
DVD player/CD player .....	37
Operating an iPod .....	39
Remote control (steering wheel switches) .....	39
Audio System (without navigation system)	
Basic operation .....	45
Radio .....	46
CD player .....	47
Operating an iPod .....	49
Remote control (steering wheel switches) .....	50
Automatic High Beam .....	22
Back Door .....	65
Cruise Control .....	15
Door Locks .....	63
Dynamic Radar Cruise Control .....	16
Eco Driving Indicator .....	14
Engine (Ignition) Switch .....	10
Fuel Tank Cap .....	66
Hands-free System For Cellular Phone (with navigation system)	
Bluetooth <sup>®</sup> phone pairing .....	31
Phonebook transfer .....	32
Registering a speed dial .....	33
Calling by name .....	34
Receiving a call .....	35

Hands-free System For Cellular Phone (without navigation system)	
Bluetooth® phone pairing .....	41
Calling by number .....	42
Calling by name.....	42
Phonebook transfer .....	43
Registering a speed dial.....	44
Headlights .....	19
Head-up Display .....	18
Intuitive Parking Assist.....	11
Keys .....	7
Lexus Enform with Safety Connect.....	61
Moon Roof.....	64
Multi-information Display and Switch.....	12
Navigation System	
Register home.....	26
Destination input — Search by address .....	27
Destination input — Search points of interest by name.....	28
Destination input — Search points of interest by category.....	29
Destination input — Search points of interest by telephone number .....	30
Portable Audio Device Ports.....	58
Power Windows .....	64
Rear Window Wiper and Washer.....	23
Remote Touch	
Basic operation.....	24
Start .....	25
Display.....	25
Safety Connect .....	59
Smart Access System with Push-button Start .....	8
Theft Deterrent System .....	9
Turn Signal Lever .....	17
Voice Command System	
Basic operation.....	52
Command list.....	53
Windshield Wipers and Washer.....	20

# Overview

# Instrument Panel

- Headlight switch P.19
- Automatic high beam P.22
- Turn signal lever P.17

Fuel filler door opener P.66

Power back door switch \* P.65

Multi-information display P.12

Inside lock buttons P.63

Window lock switch P.64

Power window switches P.64

Door lock switches P.63

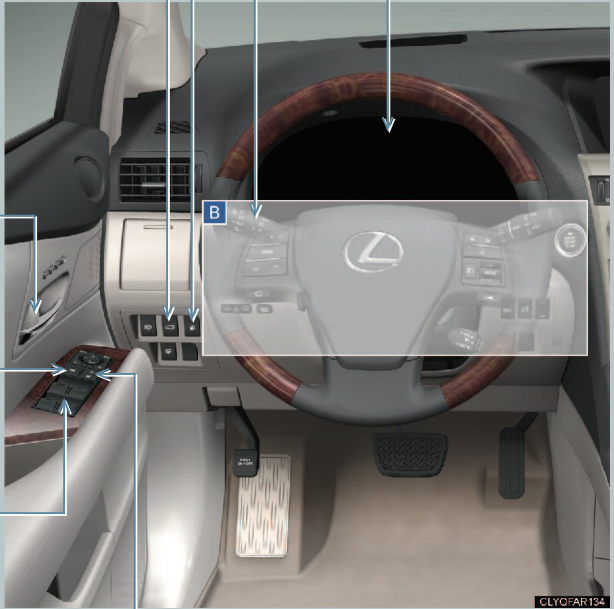

Windshield wiper and washer switch P.20

Rear window wiper and washer switch P.23

Engine (ignition) switch P.10



Power back door main switch \* P.66

Remote Touch \* P.24

Head-up display main switch \* P.18

\* : If equipped

**A**

► With navigation system

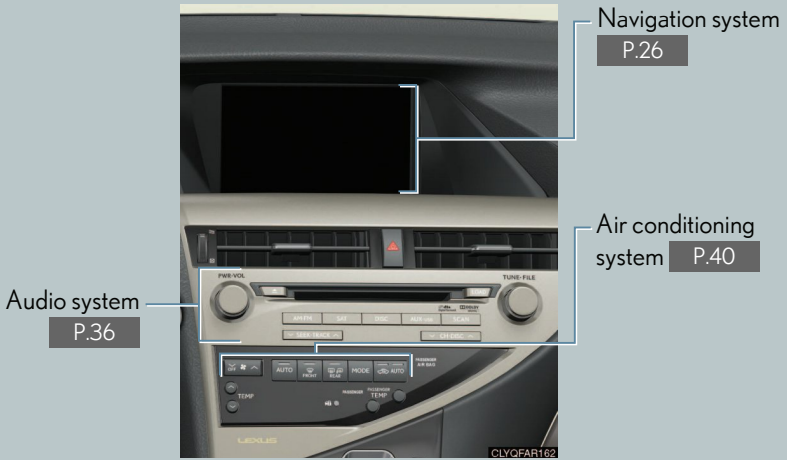

► Without navigation system



B

Multi-information switches P.12

Telephone switches \* P.31, 41

Talk switch \* P.31, 41, 52

Audio remote control switches P.50, 39



Cruise control switch P.15, 16

Distance switch \* P.16

\* : If equipped

## Keys

### n Electronic key



Smart access system with push-button start  
(→P.8, 10)

\*: If equipped

### n Mechanical key



- 1 Locks and unlocks the doors
- 1 Locks and unlocks the glove box

The mechanical key is stored inside the electronic key. To extract the key, release the latch and pull, or if equipped with a card key, press the button and pull.

### n Wireless remote control



- 1 **Press**: locks all doors
- 2 **Press once**: unlocks the driver's door  
**Press twice**: unlocks all doors
- 3 **Press and hold**: Opens and closes the back door\*
- 4 **Press and hold**: sounds the alarm  
(Use the alarm to attract attention to the vehicle in order to help deter break-ins. To stop the alarm, press any button on the wireless remote control.)

\*: If equipped

## Smart Access System with Push-button Start

The smart access system with push-button start allows you to enter and exit the vehicle or start the engine by simply carrying the electronic key in your pocket or bag. For details on starting the engine, see page 10.

### n Entering the vehicle



To unlock the vehicle, simply grasp either of the front door handles.

### n Exiting the vehicle



To lock the vehicle, touch the lock sensor on either of the front door handles.

### n Locking and unlocking the back door

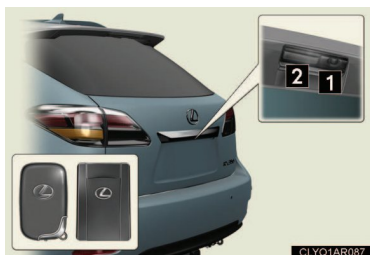

- 1 Locks
- 2 Unlocks

For details on what to do when the electronic key does not operate properly, see page 69.



## Theft Deterrent System

The theft deterrent system includes the following features to help protect your vehicle from theft.

### n Engine immobilizer system



The engine immobilizer system prevents the engine from being started in the event that an attempt is made to start the vehicle using an unregistered key.

The security indicator light flashes to indicate that the system is set.

### n Alarm

The system sounds the alarm and flashes lights when an attempt to steal the vehicle is detected.

**To set the alarm:** close the doors and hood, and lock all doors. The security indicator light comes on to indicate that the alarm is in its preparation state. When the indicator light begins to flash, the system is armed.

**To deactivate or stop the alarm:** turn the “ENGINE START STOP” switch to ACCESSORY or IGNITION ON mode, start the engine, or unlock the doors.

### n Steering lock



The steering wheel locks when the “ENGINE START STOP” switch is turned off and the driver’s door is opened.

When the steering lock cannot be released, the green indicator light on the “ENGINE START STOP” switch will flash and a message will be shown on the multi-information display. To release it, press the “ENGINE START STOP” switch while gently turning the steering wheel left or right.

## Engine (Ignition) Switch

With the electronic key on your person, the engine can be started by simply pressing the “ENGINE START STOP” switch, while depressing the brake pedal.  
(The mechanical key cannot be used to start the engine.)

### n Starting the engine



Make sure the parking brake is set and the shift lever is in P.

- 1 Depress the brake pedal.  
The “ENGINE START STOP” switch indicator light turns green.
- 2 Press the “ENGINE START STOP” switch.

### n Stopping the engine

- 1 Set the parking brake and shift the shift lever to P.
- 2 Press the “ENGINE START STOP” switch.

If the shift lever is in a position other than P when turning off the engine, the “ENGINE START STOP” switch will be turned to ACCESSORY mode, not to OFF. To avoid unexpected battery discharge, make sure the lever is in the P position when stopping the engine.

To change the “ENGINE START STOP” switch mode without turning on the engine, press the “ENGINE START STOP” switch without depressing the brake pedal. The mode can be changed in the following order:

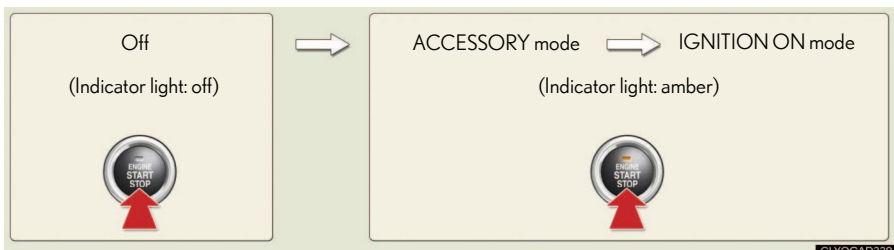

## Intuitive Parking Assist (If Equipped)

The system uses a screen display and buzzer to inform the driver of obstacles near the vehicle when parking or driving at low speed.

Owners of models equipped with a navigation system should refer to the “Navigation System Owner’s Manual”.

### n Turning the system on and off



- 1 Press the menu switch
- 2 Press the “ENTER” switch upwards or downwards until the Intuitive parking assist-sensor mark appears in the multi-information display.



- 3 Press the “ENTER” switch to select on/off.

Press the menu switch to change to the normal display.

### n Screen display

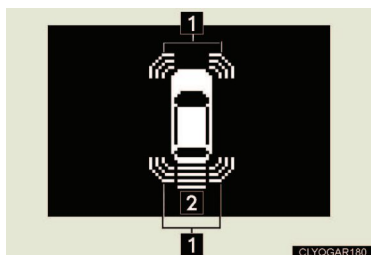

Sensors are used to detect obstacles near the vehicle. The distance to a detected obstacle is shown by the number of indicator bars.

- 1 Indicates obstacles detected by the corner sensors
- 2 Indicates obstacles detected by the back sensors

## Multi-information Display and Switch

The multi-information display shows information about your vehicle, including the items shown below.

### n Multi-information switches



- 1** Menu switch  
Changes modes to electronic features control mode, customization mode or back to normal display mode.
- 2** “ENTER” switch  
Changes trip information items. This switch is also used to turn on/off electronic features controls and to change customization settings.

### n Display contents

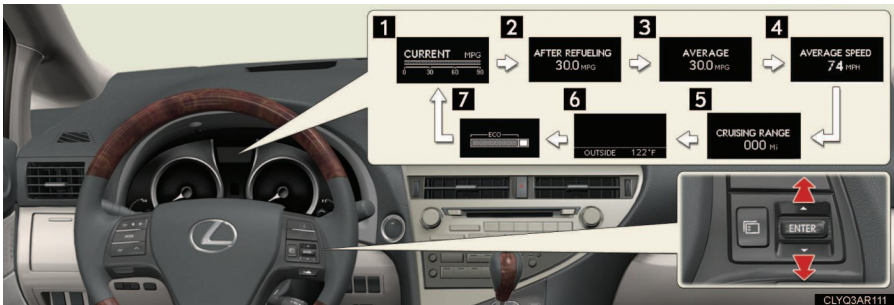

Trip information contents	Switching display items
<b>1</b> Current fuel consumption	Pressing the “ENTER” switch upwards or downwards.
<b>2</b> Average fuel consumption after refueling	
<b>3</b> Average fuel consumption	
<b>4</b> Average vehicle speed	
<b>5</b> Cruising range	
<b>6</b> Multi-information display OFF	
<b>7</b> Eco Driving Indicator Zone Display	



Electronic features control contents	Setting electronic features controls
<b>1</b> Intuitive parking assist*	→P. 11
<b>2</b> Snow mode	For details, see the Owner's Manual.
<b>3</b> AFS*	For details, see the Owner's Manual.

Other contents	Customizing settings and other information to be displayed
Outside temperature	For details, see the Owner's Manual.
Customization	
Dynamic radar cruise control settings*	
Warning message	

\*: If equipped

- n When using Intuitive parking assist-sensor or dynamic radar cruise control the appropriate display is shown on the screen.
- n In the event that a problem is detected in any of the vehicle's systems, a warning message is shown on the multi-information display.

## Eco Driving Indicator

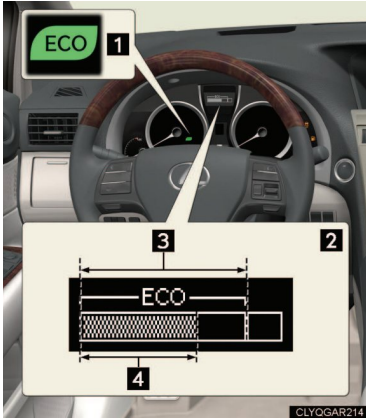

- 1 Eco Driving Indicator Light**  
During Eco-friendly acceleration (Eco driving), the Eco Driving Indicator Light will turn on.
- 2 Eco Driving Indicator Zone Display**  
Suggests Eco driving range with current Eco driving ratio based on acceleration.
- 3 Zone of Eco driving**
- 4 Eco driving ratio based on acceleration**  
If Zone of Eco driving is exceeded, the right of Eco Driving Indicator Zone Display will blink and Eco Driving Indicator Light will turn off.

## Cruise Control (If Equipped)

Cruise control allows the driver to maintain a constant speed without having to operate the accelerator pedal.

Use for highway driving or when traveling at a constant speed for long periods of time.



- 1 Indicator
- 2 Display
- 3 Cruise control switch

### n Setting the speed



- 1 Press the "ON-OFF" button.  
The system will turn on.
- 2 Accelerate or decelerate to the desired speed, and then push the lever down.  
This sets the speed in the cruise control memory.

### n Canceling

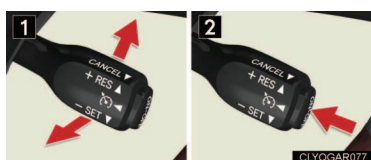

- 1 To temporarily cancel the cruise control, pull the lever toward you. To resume the cruise control, push the lever up.
- 2 To turn the system off, press the "ON-OFF" button.

### n Adjusting the speed setting



- To increase speed:** push the lever up.  
**To decrease speed:** push the lever down.

Release the lever when the desired speed is reached.

## Dynamic Radar Cruise Control (If Equipped)

Dynamic radar cruise control supplements conventional cruise control with a vehicle-to-vehicle distance control mode.

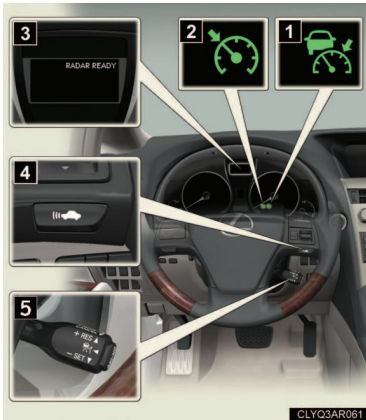

- 1 Indicator (vehicle-to-vehicle distance control mode)
- 2 Indicator (constant vehicle speed control mode)
- 3 Display
- 4 Distance switch
- 5 Cruise control switch

### n Cruise control display



Cruise control settings are shown on the multi-information display.

- 1 Vehicle ahead indicator
- 2 Vehicle-to-vehicle distance
- 3 Preset speed

### n Vehicle-to-vehicle distance control mode



- 1 Press the "ON-OFF" button.
- 2 Accelerate or decelerate to the desired speed, and then push the lever down. Vehicle-to-vehicle distance can be adjusted using the distance switch.

### n Constant speed control mode



- 1 Press the "ON-OFF" button.
- 2 Push the lever forward and hold for at least one second.
- 3 Accelerate or decelerate to the desired speed, and then push the lever down.



## n Canceling

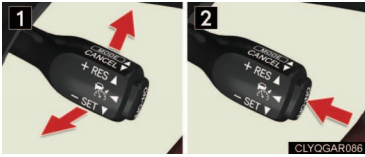

- 1 To temporarily cancel the dynamic radar cruise control, pull the lever toward you. To resume the cruise control, push the lever up.
- 2 To turn the system off, press the “ON-OFF” button.

## n Adjusting the speed setting

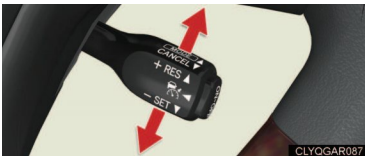

- To increase speed: push the lever up.  
To decrease speed: push the lever down.

Release the lever when the desired speed is reached.

The vehicle-to-vehicle distance control mode maintains the preset cruising speed as long as no vehicle is detected ahead.

## Turn Signal Lever



- 1 Right turn signal
- 2 Left turn signal

To signal a lane change, move the lever partway and hold.

## Head-up Display (If Equipped)

The head-up display can be used to project vehicle speed and other information onto the windshield.

### n Head-up display switches

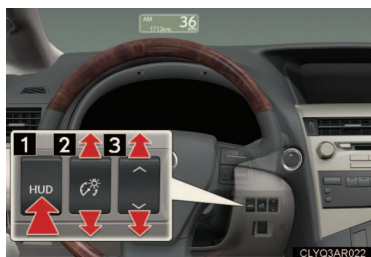

- 1 Pressing the switch turns the head-up display on/off and changes the vehicle speed display units.
- 2 Adjusting display contrast
- 3 Adjusting display position

### n Head-up display contents

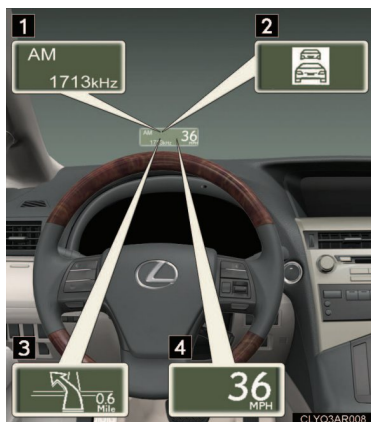

- 1 Audio display
- 2 Dynamic radar cruise control (if equipped)
- 3 Turn-by-turn navigation\*
- 4 Vehicle speed display



- n When using audio system or navigation system the appropriate display is shown on the screen.
- n In the event that a problem is detected in any of the vehicle's systems, a warning message is shown on the head-up display.
- n Pressing and holding the head-up display main switch for more than 2 seconds changes the display to audio display on/off mode. Press the head-up display main switch to turn the audio display on/off.
- n The head-up display may seem dark and hard to see when head viewed through sunglasses, especially polarized sunglasses.  
Adjust the brightness of the head-up display or remove your sunglasses.

\*: Refer to "Navigation System Owner's Manual".

# Headlights



## ► U.S.A

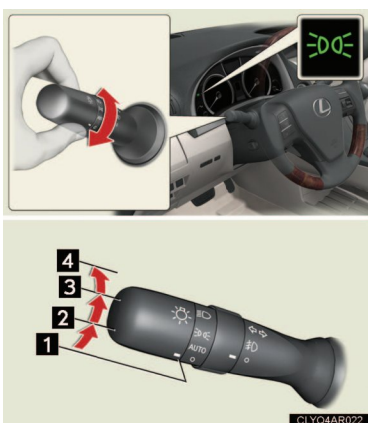

- 1 **AUTO** The headlights, side marker, parking, tail, license plate, daytime running lights and instrument panel lights turn on/off automatically in accordance with ambient light levels.
- 2  The instrument panel, side marker, parking, tail, license plate and daytime running lights turn on.
- 3  The headlights and all lights listed above turn on.
- 4 **DRL OFF** The daytime running light turn off.

## ► Canada



- 1  The daytime running lights turn on.
- 2 **AUTO** The headlights, side marker, parking, tail, license plate, daytime running lights and instrument panel lights turn on/off automatically in accordance with ambient light levels.
- 3  The instrument panel, side marker, parking, tail, license plate and daytime running lights turn on.
- 4  The headlights and all lights listed above turn on.

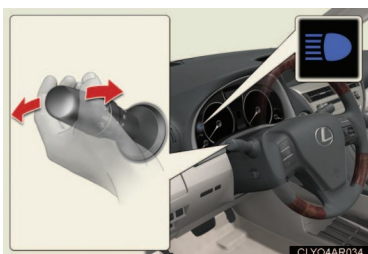





To engage the high beams, push the lever forward. To flash the high beams temporarily, pull the lever toward you.

## Windshield Wipers and Washer

### n Intermittent wiper with interval adjuster (if equipped)



- 1  Off
- 2  Intermittent operation
- 3  Low speed
- 4  High speed
- 5  Temporary operation

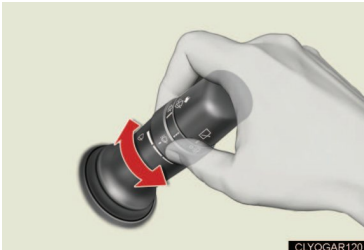
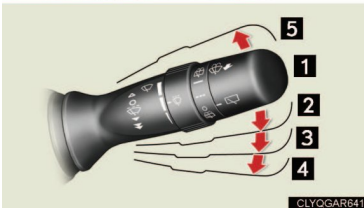

Intermittent operation: Wiper interval can be adjusted by turning the band.



To spray washer fluid, pull the lever. The wipers will operate automatically.

## n Rain-sensing windshield wipers (if equipped)



- 1 ○ Off
- 2 AUTO Automatic operation
- 3 ▼ Low speed
- 4 ▼ High speed
- 5 ▲ Temporary operation

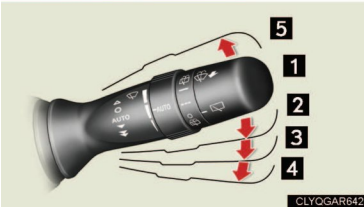

CLYOGAR642

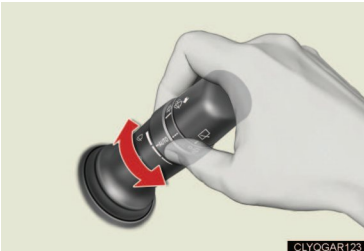

CLYOGAR123

Automatic operation: sensitivity can be adjusted by turning the band.

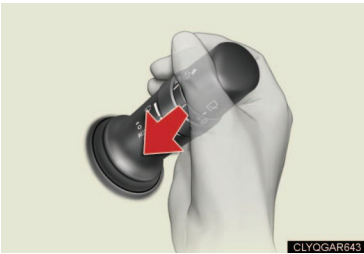

CLYOGAR843

To spray washer fluid, pull the lever. The wipers will operate automatically.

## Automatic High Beam (If Equipped)

The Automatic High Beam uses an in-vehicle camera sensor to assess the brightness of streetlights, the lights of oncoming and preceding vehicles, etc., and automatically turns high beam on or off as necessary.



1 Headlight switch in "AUTO" position.

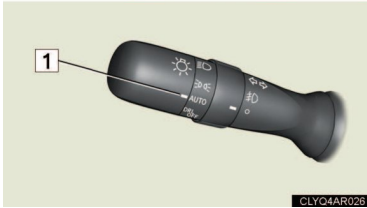

CLY04AR026

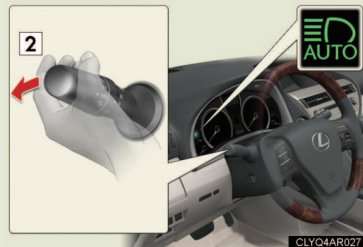





2 Push the lever away from you.

When all of the following conditions are fulfilled, high beam will be automatically turned on (after approximately 1 second):

- Vehicle speed is above approximately 20 mph (32 km/h).
- The area ahead of the vehicle is dark.
- There are no oncoming or preceding vehicles with headlights or tail lights turned on.

## Rear Window Wiper and Washer



- 1  Off
- 2  Intermittent window wiper operation
- 3  Normal window wiper operation
- 4  Washer/wiper dual operation
- 5  Washer/wiper dual operation

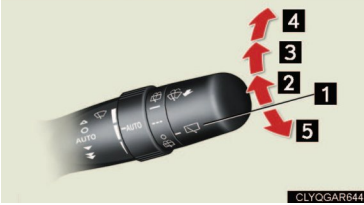

CLYOGAR644

## Remote Touch (If Equipped)

The Remote Touch can be used to operate the navigation screens and configure settings.

### n Basic operation

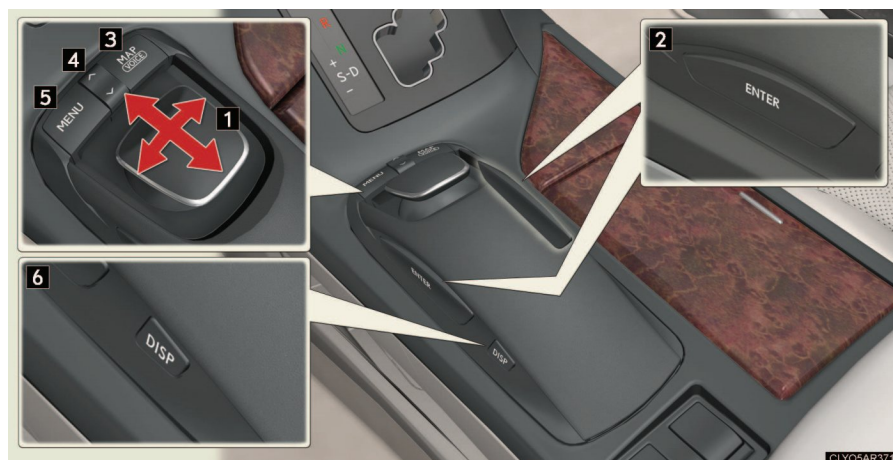

- 1 Remote Touch knob**  
Use this knob to move the cursor and select items on the screen.  
Feedback force, selection sounds and pointer shape can be changed. Refer to the "Navigation System Owner's Manual".
- 2 "ENTER" button**  
Press this button to confirm a selection.
- 3 "MAP/VOICE" button**  
Press this button to display the vehicle's current position.
- 4 "∧∨" button**  
Press these buttons to change map scale and scroll through lists.
- 5 "MENU" button**  
Press this button to display the "Start" (menu) screen.
- 6 "DISP" button**  
Press this button to adjust picture quality.



## n Start

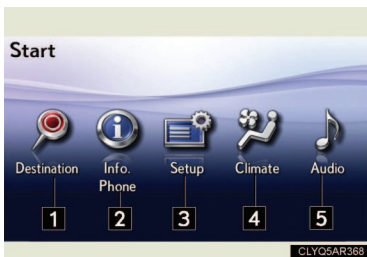

Press the "MENU" button on the Remote Touch to display the "Start" screen.

- 1 Destination (→P.26)
- 2 Info.Phone
- 3 Setup (→P.26, 31)
- 4 Climate (→P.40)
- 5 Audio (→P.36)

## n Display



Press the "DISP" button on the Remote Touch to show the "Display" screen.

- 1 Turns the rear seat entertainment system on and off
- 2 Displays the screen in "Day Mode" with the headlight switch on
- 3 Turns the screen off
- 4 Adjust contrast
- 5 Adjust brightness
- 6 Adjust color tone
- 7 Adjust color

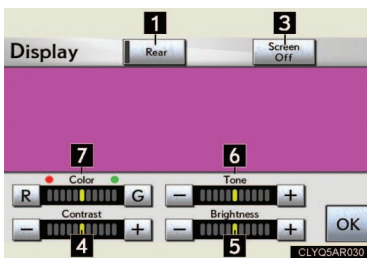

## Navigation System (If Equipped)

### n Register home

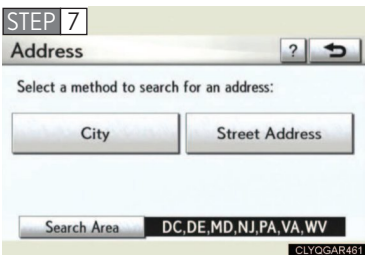
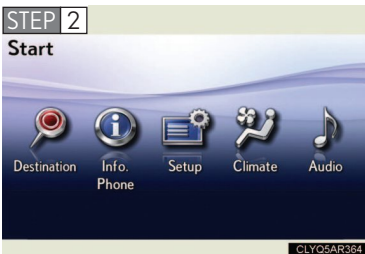

- 1 Press the "MENU" button.  
The "Start" screen will be displayed.

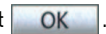

- 8 Input a city name and select  .

- 9 Select the button of the desired city name from the displayed list.

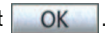
- 10 Input the street name and select  .

- 11 When the desired street name is found, select the corresponding button.



- 12 Input a house number and select  .

- 13 Select  .  
Enter

- 14 Select  .  
OK

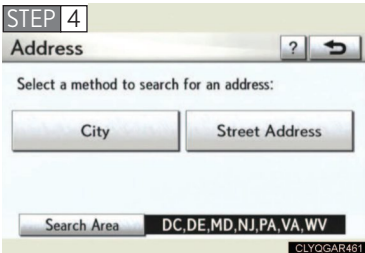
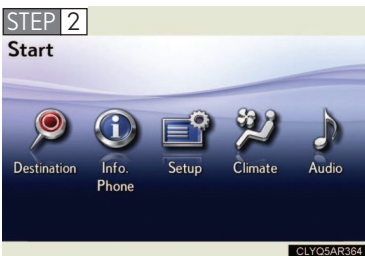

## n Destination input — Search by address



- 1 Press the “MENU” button.  
The “Start” screen will be displayed.
- 2 Select  .
- 3 Select  .
- 4 Select  .
- 5 Input a city name and select  .
- 6 Select the button of the desired city name from the displayed list.
- 7 Input the street name and select  .
- 8 When the desired street name is found, select the corresponding button.
- 9 Input a house number and select  .
- 10 Select  .
- 11 Select  .

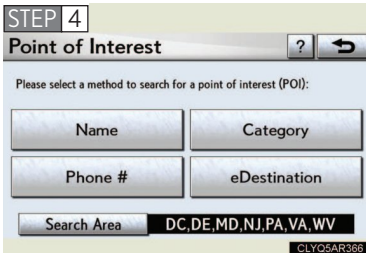
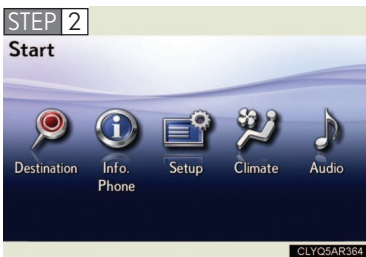





## n Destination input — Search points of interest by name

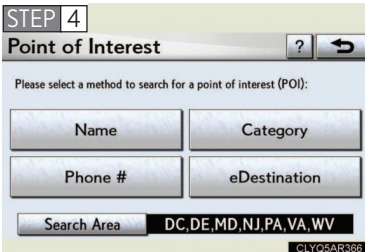
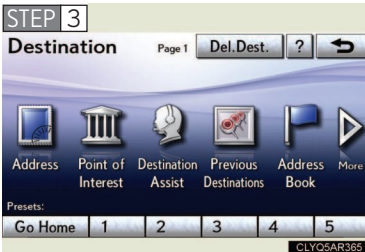
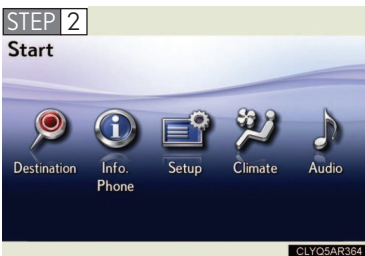

- 1 Press the “MENU” button.  
The “Start” screen will be displayed.
- 2 Select  .
- 3 Select  .
- 4 Select  .
- 5 Input the name of the point of interest and select  .
- 6 Select the button of the desired destination.
- 7 Select  .
- 8 Select  .



## n Destination input — Search points of interest by category

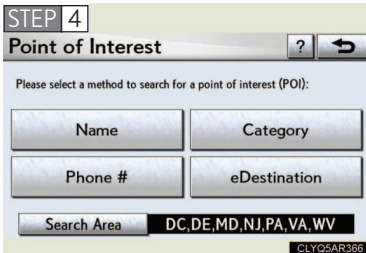
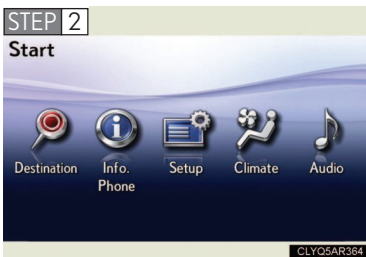

- 1 Press the “MENU” button.  
The “Start” screen will be displayed.
- 2 Select  .
- 3 Select  .
- 4 Select  .
- 5 Select  .
- 6 Select the button of the desired destination and set the search point.
- 7 Select the desired point of interest category.
- 8 Select the button of the desired item.
- 9 Select  .
- 10 Select  .

## n Destination input — Search points of interest by telephone number



- 1 Press the "MENU" button.  
The "Start" screen will be displayed.
- 2 Select  .
- 3 Select  .
- 4 Select  .
- 5 Input a telephone number and select  .
- 6 Select  .
- 7 Select  .

# Hands-free System For Cellular Phone (with navigation system)

## n Bluetooth® phone pairing

Compatible Bluetooth®-equipped phones can be connected to the vehicle, enabling hands-free operation. Please refer to the cellular phone manufacturer's user guide for pairing procedures, or go to [www.lexus.com/bluetooth](http://www.lexus.com/bluetooth) for more phone information.

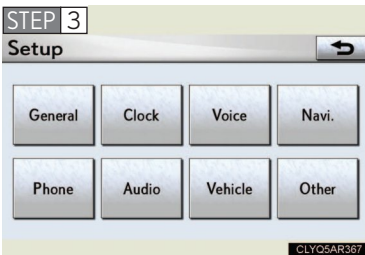

To use a Bluetooth® phone, it is necessary to first register it in the system.

1 Press the "MENU" button.

The "Start" screen will be displayed.

2 Select  .

3 Select  .

4 Select  .

5 Select  to display the screen for connecting Bluetooth.





6 Enter the passcode displayed on the screen into the phone.

Refer to the cellular phone user's manual for cellular phone operation.

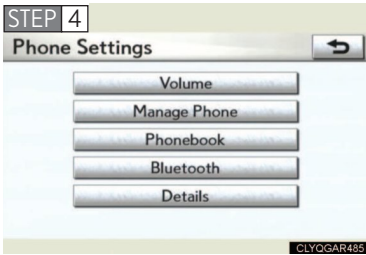
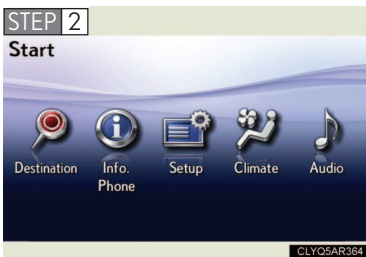
7 When the connection is completed, a message will appear indicating that the phone has been connected successfully.

## n Phonebook transfer







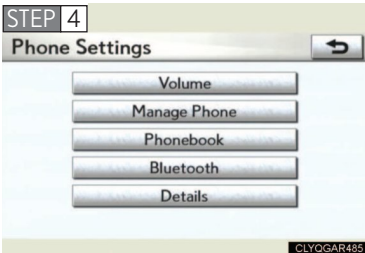

- 1 Press the "MENU" button.  
The "Start" screen will be displayed.
- 2 Select  .
- 3 Select  .
- 4 Select  .
- 5 Select  .
- 6 Select  .
- 7 Transfer the phonebook data to the system using the cellular phone.  
Refer to the cellular phone user's manual for cellular phone operation.

Phonebook transfer may not be possible depending on phone model.



## n Registering a speed dial



- 1 Press the "MENU" button.  
The "Start" screen will be displayed.
- 2 Select  .
- 3 Select  .
- 4 Select  .
- 5 Select  .
- 6 Select  .
- 7 Select the data you want to register.
- 8 Select the desired phone number.
- 9 Select the button you want to register in.
- 10 The registration completion message is displayed on the screen.

## n Calling by name

You can call by saying a voice tag registered in the phonebook. For setting the voice recognition, refer to the "Navigation System Owner's Manual". Only when English is selected as the system language can you call by saying a name registered in the phonebook without registering any voice tags beforehand. (Names in the phonebook work as voice tags.)

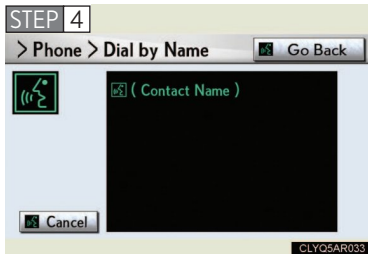
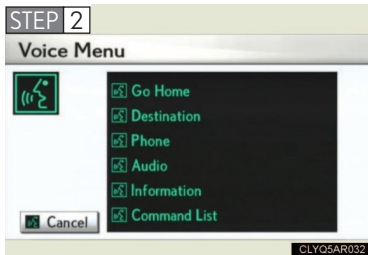
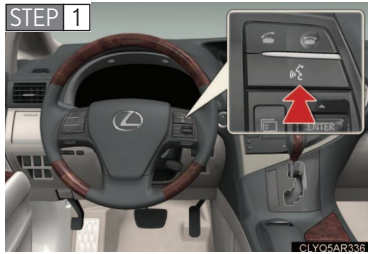

- 1 Press .
- 2 Follow the voice guidance and say "Phone".
- 3 Follow the voice guidance and say "Dial by name".
- 4 Follow the voice guidance and say a contact name.
- 5 Follow the voice guidance and say the type of phone number (home, mobile, work, other).
- 6 Follow the voice guidance and say "Dial".



: Pressing this switch turns the speech command system on. Say a command after the beep.

## n Receiving a call

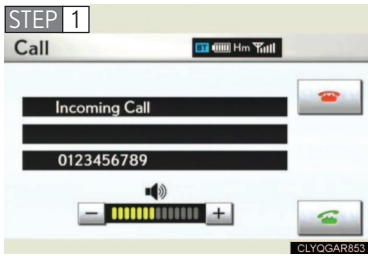

1 When a call is received, this screen is displayed with a sound.

2 Press  on the steering wheel to talk on the phone.

To ignore the call, press  on the steering wheel.

## Audio System (with navigation system)

### n Audio control screen

Follow the procedure below to display the audio control screen.



- 1 Press the "MENU" button on the Remote Touch.

Please refer to P.24 for the Remote Touch operation.

The "Start" screen will be displayed.

- 2 Using the Remote Touch, select "Audio" and press the "ENTER" button.

### n Basic operation



- 1 Sound quality modes

- 2 Audio sources

**AM·FM:** AM radio/FM radio

**AM:** AM radio

**SAT:** Satellite radio

**FM:** FM radio

**DISC (if equipped):** DVD player

**CD (if equipped):** CD player

**AUX·USB (if equipped):** Auxiliary audio device/USB memory/iPod/Bluetooth® audio

**AUX (if equipped):** Auxiliary audio device/USB memory/iPod/Bluetooth® audio

- 3 Power/Volume

## n Radio

---

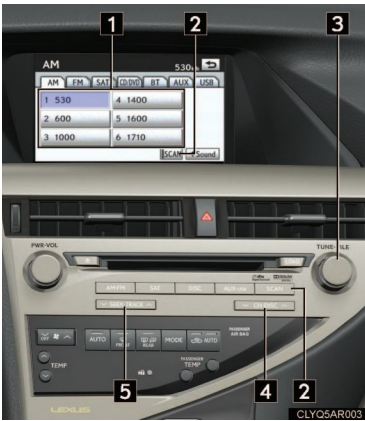

- 1 Station presets
- 2 Scanning radio stations
- 3 Radio tuner
- 4 Station select
- 5 Seek

## n Entering station presets

- 1 Select the desired station by using the tune, seek or scan function.
- 2 Using the Remote Touch, select one of the preset switches (1-6), then press the “ENTER” button until a beep is heard, indicating that the station has been set.

## n DVD player/CD player

---

### n Playing an audio CD



- 1 Disc select
- 2 Repeat play
- 3 Random playback
- 4 Search playback
- 5 Disc load
- 6 Track select/rewind/fast-forward
- 7 Eject

**n** Playing a CD with MP3/WMA files



- 1** Disc select
- 2** Repeat play
- 3** Random playback
- 4** Search playback
- 5** Folder select
- 6** Disc load
- 7** File select
- 8** Eject

**n** Playing a DVD (DVD player only)

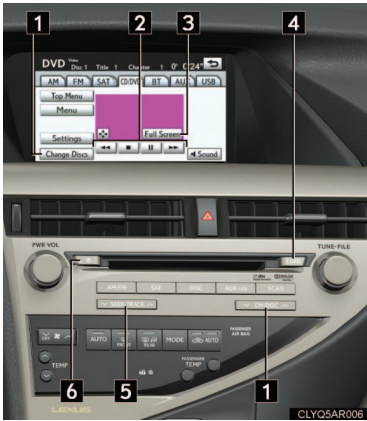

- 1** Disc select
- 2** DVD operation
- 3** Image display (full screen)
- 4** Disc load
- 5** Chapter select
- 6** Eject

## n Loading a disc

- 1 Press the "LOAD" button.
- 2 When the indicator changes from flashing amber to green, insert a disc after the disc slot door opens.

## n Loading multiple discs

- 1 Press and hold the "LOAD" button until you hear a beep.
- 2 When the indicator changes from flashing amber to green, insert a disc after the disc slot door opens.
- 3 After inserting a disc, wait until the indicator changes from flashing amber to green, then insert the next disc after the disc slot door has opened.

Repeat **2** and **3** until you have inserted all discs.

To cancel the operation, press the "LOAD" button. If you do not insert a disc within 15 seconds, loading will be canceled automatically.

## n Operating an iPod



- 1 Menu
- 2 Pause/Playback
- 3 Repeat play
- 4 Random playback
- 5 Song list
- 6 Go back
- 7 Song select
- 8 Song select/rewind/fast-forward

## n Remote control (steering wheel switches)

The audio system can be operated using the remote control located on the steering wheel.



- 1 Volume
- 2 Power on/change mode: press  
Power off: press and hold
- 3 Radio mode: radio tuner  
DVD mode: track/chapter/disc select  
CD mode: disc/track/file (MP3/WMA) select  
iPod mode: song select

## Air Conditioning System (with navigation system)



- |   |   |
|---|---|
| <b>1</b> Dual mode button                         | <b>8</b> Automatic mode button                                |
| <b>2</b> Passenger side temperature display       | <b>9</b> Driver side temperature control                      |
| <b>3</b> Fan speed display                        | <b>10</b> Fan speed control button/"OFF" button               |
| <b>4</b> Outside air/recirculated air mode button | <b>11</b> Cooling and dehumidification function on/off button |
| <b>5</b> Passenger side temperature control       | <b>12</b> Driver side temperature display                     |
| <b>6</b> Air outlet selector button               | <b>13</b> Air outlet display                                  |
| <b>7</b> Windshield defogger                      |   |

### n Using the automatic mode

Press **8** to turn on the airflow and **9** to adjust the temperature.

### n Adjusting the temperature

**n To simultaneously adjust the driver's side and passenger's side temperature settings**  
Select **1** to turn the "DUAL" indicator off ( **DUAL** ) and then press **9**.

**n To individually adjust the driver's side and passenger's side temperature settings**  
Select **1** or press **5** to turn the "DUAL" indicator on ( **DUAL** ) and then press **9** or **5**.

### n To turn off the airflow

Press and hold "v" on **10** until the airflow turns off.



## Hands-free System For Cellular Phone (without navigation system)

### n Bluetooth® phone pairing

Compatible Bluetooth®-equipped phones can be connected to the vehicle, enabling hands-free operation. Please refer to the cellular phone manufacturer's user guide for pairing procedures, or go to "www.lexus.com/bluetooth" for more phone information.



To use a Bluetooth® phone, it is necessary to first register it in the system.

1 Press  or .

2 Press  and say "Pair phone".

3 Press  and say a name\*.

\*: This name will be used to identify your phone in the case that more than one phone has been registered to the system.

4 Press  and say "Confirm" to display the passkey.

5 Enter the passkey shown on the display into the phone.

Refer to the cellular phone user's manual for cellular phone operation.





6 Once the voice guidance for registration completion is finished, press .

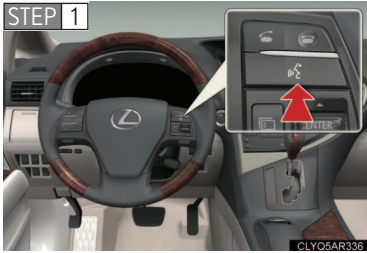

: Pressing this switch turns the speech command system on. Say a command after the beep.

## n Calling by number





- 1 Press  and say "Dial by number".
- 2 Press  and say the phone number.
- 3 Dialing
  - a. Press .
  - b. Press  and say "Dial".

## n Calling by name

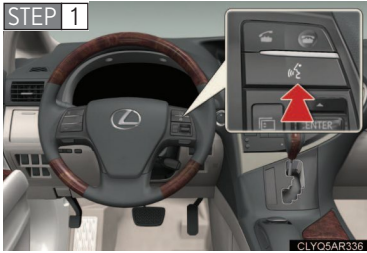
You can call by saying a voice tag registered in the phonebook. For setting the voice recognition, refer to the "Owner's Manual".











- 1 Press  and say "Dial by name".
- 2 Press  and say a contact name.
- 3 Dialing
  - a. Press .
  - b. Press  and say "Dial".



: Pressing this switch turns the speech command system on. Say a command after the beep.

## n Phonebook transfer

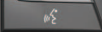

- 1 Press .
- 2 Press  and say "Phone book".
- 3 Press  and say "Add entry".
- 4 Press  and say "By phone".
- 5 Press  and say "Confirm".
- 6 Transfer the phonebook data to the system using the cellular phone.  
Refer to the cellular phone user's manual for cellular phone operation.
- 7 Press  and say "Previous" or "Next" until the desired data is displayed.
- 8 Press  and say "Confirm".
- 9 Press  and say the desired name.
- 10 Press  and say "Confirm".
- 11 Press  and say "Confirm" again.

Phonebook transfer may not be possible depending on phone model.









: Pressing this switch turns the speech command system on. Say a command after the beep.

## n Registering a speed dial

STEP 1



- 1 Press .
- 2 Press  and say "Phone book".
- 3 Press  and say "Set speed dial".
- 4 Select the data to be registered.
- 5 Press  and say the desired name.
- 6 Press  and say "Confirm".
- 7 Press the desired preset button.
- 8 Press  and say "Confirm".

STEP 7

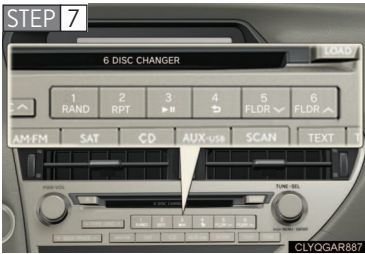

: Pressing this switch turns the speech command system on. Say a command after the beep.

# Audio System (without navigation system)

## n Basic operation

### ► Type A



1 Power/Volume

2 Audio sources

AM-FM: AM radio/FM radio

SAT: Satellite radio

CD: CD player

AUX-USB (if equipped): Auxiliary audio device/USB memory/iPod/Bluetooth® audio

AUX (if equipped): Auxiliary audio device/Bluetooth® audio

3 Sound quality modes

### ► Type B



1 Power/Volume

2 Audio sources

AM: AM radio

FM: FM radio

CD: CD player

AUX: Auxiliary audio device/USB memory/iPod

3 Mute

4 Sound quality modes

# n Radio

## ► Type A

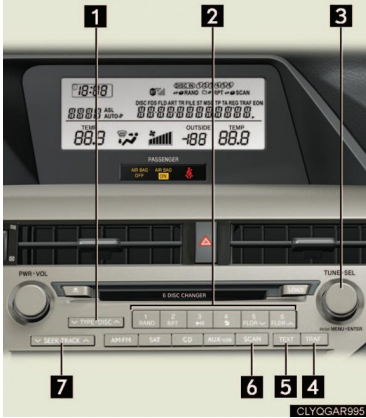

- 1 RDS genre select
- 2 Station presets
- 3 Radio tuner
- 4 Traffic information
- 5 Text messages
- 6 Scanning radio stations
- 7 Seek

## ► Type B

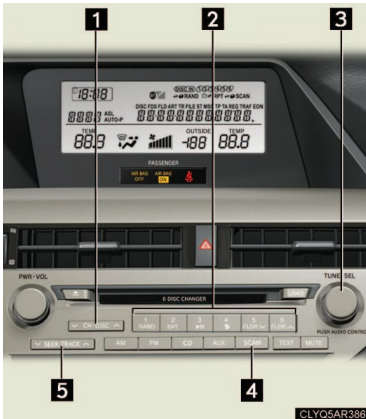

- 1 Station select
- 2 Station presets
- 3 Radio tuner
- 4 Scanning radio stations
- 5 Seek

## n Entering station presets

- 1 Select the desired station by using the tune, the seek or the scan function.
- 2 Press and hold one of the preset buttons (1-6) until you hear a beep, indicating that the station is set.

## n CD player

### n Playing an audio CD

#### ► Type A

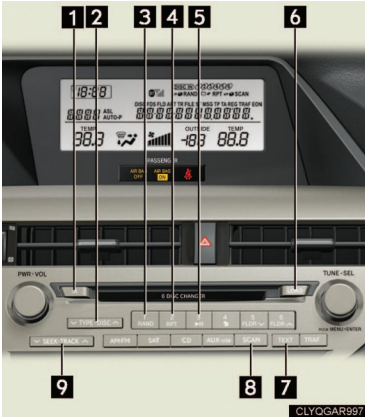

- 1 Eject
- 2 Disc select
- 3 Random playback
- 4 Repeat play
- 5 Pause/Playback
- 6 Disc load
- 7 Text information
- 8 Search playback
- 9 Track select/rewind/fast-forward

#### ► Type B

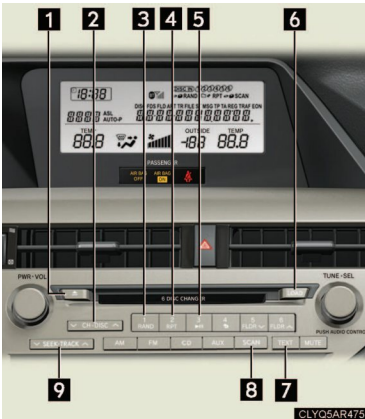

- 1 Eject
- 2 Disc select
- 3 Random playback
- 4 Repeat play
- 5 Pause/Playback
- 6 Disc load
- 7 Text information
- 8 Search playback
- 9 Track select/rewind/fast-forward

## ▶ Playing a CD with MP3/WMA files

### ▶ Type A

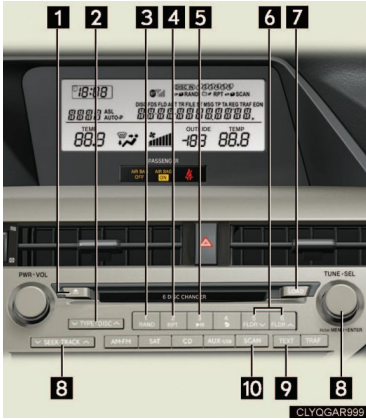

- 1 Eject
- 2 Disc select
- 3 Random playback
- 4 Repeat play
- 5 Pause/Playback
- 6 Folder select
- 7 Disc load
- 8 File select
- 9 Text information
- 10 Search playback

### ▶ Type B

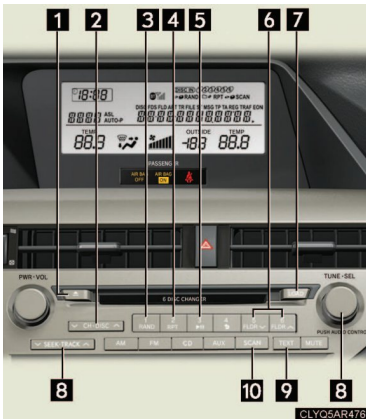

- 1 Eject
- 2 Disc select
- 3 Random playback
- 4 Repeat play
- 5 Pause/Playback
- 6 Folder select
- 7 Disc load
- 8 File select
- 9 Text information
- 10 Search playback



## n Loading a CD

- 1 Press the "LOAD" button.  
"WAIT" is shown on the display.
- 2 Insert a CD when the indicators on the slot turn from amber to green.  
The display changes from "WAIT" to "LOAD".

## n Loading multiple CDs

- 1 Press and hold the "LOAD" button until you hear a beep.  
"WAIT" is shown on the display.
- 2 Insert a CD when the indicators on the slot turn from amber to green.  
The display changes from "WAIT" to "LOAD".  
The indicators on the slot turn to amber when the CD is inserted.
- 3 Insert the next CD when the indicators on the slot turn from amber to green again.  
Repeat the procedure for the remaining CDs.  
To cancel the operation, press the "LOAD" button. If you do not insert a CD within 15 seconds, loading will be cancelled automatically.

## n Operating an iPod (if equipped)

---

### ► Type A

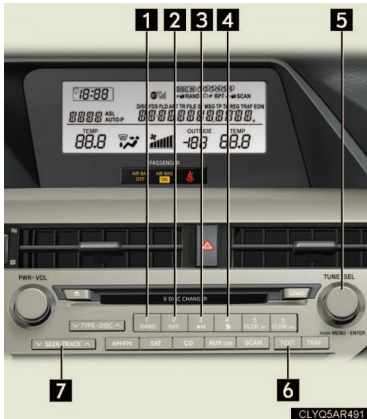

- 1 Random play
- 2 Repeat play
- 3 Pause/Playback
- 4 Go back
- 5 Menu/Song select
- 6 Text information
- 7 Song select/rewind/fast-forward

► Type B

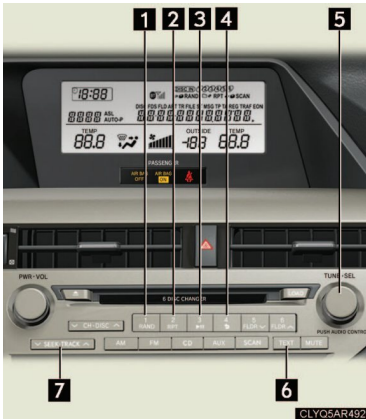

- 1 Random play
- 2 Repeat play
- 3 Pause/Playback
- 4 Go back
- 5 Menu/Song select
- 6 Text information
- 7 Song select/rewind/fast-forward

n Remote control (steering wheel switches)

The audio system can be operated using the remote control located on the steering wheel.



- 1 Volume
- 2 Power on/change mode: press  
Power off: press and hold
- 3 Radio mode: radio tuner  
CD mode: disc/track/file (MP3/WMA) select  
iPod mode (if equipped): song select

## Air Conditioning System (without navigation system)



- |  |  |
|--|--|
| <b>1</b> Passenger side temperature display                  | <b>6</b> Air outlet selector button            |
| <b>2</b> Passenger side temperature control                  | <b>7</b> Driver side temperature control       |
| <b>3</b> Cooling and dehumidification function on/off button | <b>8</b> Fan speed control button/"OFF" button |
| <b>4</b> Outside air/recirculated air mode button            | <b>9</b> Automatic mode button                 |
| <b>5</b> Windshield defogger                                 | <b>10</b> Dual mode button                     |
|  | <b>11</b> Driver side temperature display      |

### **n** Using the automatic mode

Press **9** to turn on the airflow and **7** to adjust the temperature.

### **n** Adjusting the temperature

**n** To simultaneously adjust the driver's side and passenger's side temperature settings

Press **10** to turn the "DUAL" indicator off () and then press **7**.

**n** To individually adjust the driver's side and passenger's side temperature settings

Press **10** or **2** to turn the "DUAL" indicator on () and then press **7** or **2**.



### **n** To turn off the airflow

Press and hold "v" on **8** until the airflow turns off.



## Voice Command System

### n Basic operation



- 1 Press  on the steering wheel.
- 2 - If you know the command:  
Press  again.  
- If you do not know the command:  
Follow the voice guidance to learn the command and then press  again.
- 3 Say a command after the beep.

### n Important voice commands information and tips

- Voice commands can be used while driving.
- You must wait until after the beep to say a command.
- In vehicles with a navigation system, a large TALK icon  will appear on the navigation screen to prompt you to say a command.
- If you know what command to use, you can press  at any time to interrupt the voice guidance.

## n Command list

### ► All vehicles

PHONE			
To Operate a Bluetooth Connected Phone/Make Calls, SAY:	"Phone" and then SAY:	"Dial by Name"	NOTE: You can also make a call by simply saying: "Call XXX-555-5555" ETC.
		"Dial by Number"	
		"Redial"	
		"Call Back"	
		"Mute"	

### ► With navigation system

Destinations				
To Enter an Address/ Destination, SAY: (English only)	"Destination" and then SAY:		"Address" and then follow the prompts to enter city, state, street and house number	
To Enter a Point of Interest, SAY	A Point of Interest Category, Such As: "Dining," "Shopping Malls," "Police," "Gas," ETC.			
	"Destination" and then SAY:	"Point of Interest" and then SAY:	"Near Here"	And then follow the prompts
			"Along Route"	
			"Emergency"	
"Phone Number"				
To Enter a Previous Destination, SAY:	"Destination" and then SAY:		"Previous Destinations"	
To Enter/Go to Preset Destinations, SAY:	"Destination" and then SAY:	"Presets" and then SAY:	"Home" (HOME must already be set using manual controls)	
			"Preset 1" or "Preset 2" ETC. (preset addresses must already be set using manual controls)	

## General Navigation Commands

To Change the Map Screen, SAY:	"Map"
	"Dual Map"
	"Single Map"
	"Compass Mode"
To Change the Map Scale/ Size, SAY:	"Zoom In"
	"Zoom Out"
	"Right Map Zoom In"
	"Right Map Zoom Out"
	"North Up"
	"Heading Up"
To Change the Map Orientation, SAY:	"Map Direction"
	"Right Map North Up"
	"Right Map Heading Up"
To Change the Guidance Mode, SAY:	"Right Map Direction"
	"Arrow Mode"
	"Turn List Mode"
	"Intersection Mode"
To Save a Point on the Map, SAY:	"Freeway Mode"
	"Mark This Point"
To Remove Icons from Map, SAY:	"Clear All Icons"
To Set the Destination, SAY:	"Previous Start Point"
To Change the Route, SAY:	"Quick Route"
	"Short Route"
	"Alternate Route"
	"Detour"
	"Detour Entire Route"

## General Navigation Commands

To Review the Route, SAY:	"Route Overview"
	"Next Destination Map"
	"First Destination Map"
	"Second Destination Map"
	"Third Destination Map"
	"Fourth Destination Map"
	"Fifth Destination Map"
To Delete the Destination, SAY:	"Final Destination Map"
	"Delete Next Destination"
	"Delete Final Destination"
To Operate Guidance Options, SAY:	"Delete All Destinations"
	"Pause Guidance"
	"Resume Guidance"
	"Repeat Guidance"
To Operate the Traffic Information, SAY:	"Louder"
	"Softer"
To Operate the Traffic Information, SAY:	"Traffic Information"
To Show the Icon, SAY:	"Show GAS", "Show PARKING" ETC.

## PHONE

To Operate a Bluetooth Connected Phone/Make Calls, SAY:	"Phone" and then SAY:	"Send Tones"		NOTE: You can also make a call by simply saying: "Call XXX-555-5555" ETC.
		"Connect Phone" and then SAY:	"Send Phone"	
			"Add New Phone"	
			"Hands Free Power ON"	
			"Hands Free Power OFF"	

## AUDIO

To Turn Audio On or Off, SAY:	"Audio ON"		
	"Audio OFF"		
To Change the Audio Mode, SAY:	FM, AM, Radio, Satellite Radio, Auxiliary, CD*, CD Changer*, DVD**, DVD Changer**, Bluetooth® Audio, iPod, USB Audio  *For systems w/o NAV **For systems w/NAV		
To Change to a different CD/DVD track, SAY:	"Track Up", "Track Down" or "Previous Track"		
To Change to a different CD/DVD, SAY:	"Disc Up" "Disc Down"		
To Change Radio Stations, SAY:	"Seek Up" or "Seek Down"		
	"Type Up" or "Type Down"		
To Operate Satellite RadioXM Controls, SAY:	"Satellite Radio" and then SAY:	"Select Channel Number"	
		"Select Channel Name" (English only)	
		"Select Channel Type" (English only)	
		"Command List" and then SAY:	"Seek Up" or "Seek Down" "Type Up" or "Type Down"



XM Information		
To Operate XM NavWeather, SAY: (English only)	"Information" and then SAY:	"XM NavWeather" and follow the prompts
To Operate XM NavTraffic, SAY: (English only)	"Information" and then SAY:	"XM NavTraffic" and follow the prompts
To Operate XM Sports, SAY: (English only)	"Information" and then SAY:	"XM Sports" and follow the prompts
To Operate XM Stocks, SAY: (English only)	"Information" and then SAY:	"XM Stocks" and follow the prompts
To Operate Lexus Insider, SAY:	"Information" and then SAY:	"Lexus Insider" and follow the prompts

CLIMATE CONTROL/AIR CONDITIONING	
To Turn On and Adjust setting for Climate Control and Temperature, SAY:	"Automatic Climate Control"
	"Raise Temperature"
	"Lower Temperature"
To Set a Specific Temperature, SAY:	"70 Degrees" or "65 Degrees" ETC.

## Portable Audio Device Ports

These ports can be used to connect a portable audio device and listen to it through the vehicle's speakers.

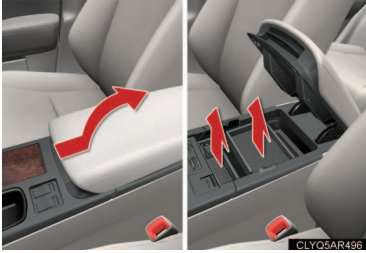

- 1 Slide the armrest while pulling up the lever, and lift the armrest.  
Remove the upper trays. (if equipped)

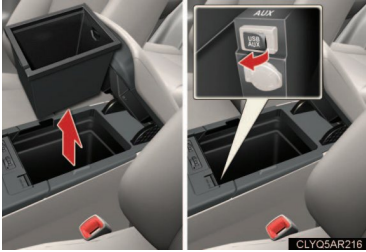

- 2 Remove the lower tray and open the cover.



- 1 USB port (if equipped)
- 2 AUX port

## Safety Connect (If Equipped)

Safety Connect is a subscription-based telematics service that uses Global Positioning System (GPS) data and embedded cellular technology to provide safety and security features to subscribers. Safety Connect is supported by Lexus' designated response center, which operates 24 hours per day, 7 days per week.

Safety Connect service is available by subscription on select, telematics hardware-equipped vehicles.

### n System components

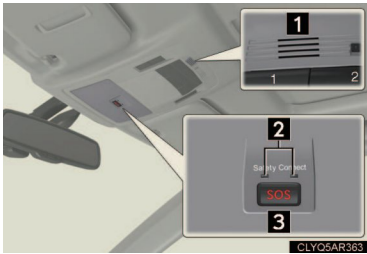

- 1 Microphone
- 2 LED light indicators
- 3 "SOS" button

### n Services

Subscribers have the following Safety Connect services available:

#### 1 Automatic Collision Notification\*

In case of either airbag deployment or severe rear-end collision, the system is designed to automatically call the response center. The responding agent receives the vehicle's location and attempts to speak with the vehicle occupants to assess the level of emergency. If the occupants are unable to communicate, the agent automatically treats the call as an emergency, contacts the nearest emergency services provider to describe the situation, and requests that assistance be sent to the location.

\*: U.S. Patent No. 7,508,298 B2

#### 1 Stolen Vehicle Location

If your vehicle is stolen, Safety Connect can work with local authorities to assist them in locating and recovering the vehicle. After filing a police report, call the Safety Connect response center at 1-800-25-LEXUS (1-800-255-3987) and follow the prompts for Safety Connect to initiate this service.

In addition to assisting law enforcement with recovery of a stolen vehicle, Safety-Connect-equipped vehicle location data may, under certain circumstances, be shared with third parties to locate your vehicle. Further information is available at [Lexus.com](http://Lexus.com).

### **l Emergency Assistance Button (SOS)**

In the event of an emergency on the road, push the “SOS” button to reach the Safety Connect response center. The answering agent will determine your vehicle’s location, assess the emergency, and dispatch the necessary assistance required.

If you accidentally push the “SOS” button, tell the response-center agent that you are not experiencing an emergency.

### **l Enhanced Roadside Assistance**

Subscribers can push the “SOS” button to reach a Safety Connect response-center agent, who can help with a wide range of needs, such as: towing, flat tire, fuel delivery, etc. For a description of the Roadside Assistance services and their limitations, please see the Safety Connect Terms and Conditions, which are available at [Lexus.com](http://Lexus.com).

### **n Subscription**

---

After you have signed the Telematics Subscription Service Agreement and are enrolled, you can begin receiving services.

A variety of subscription terms is available for purchase. Contact your Lexus dealer, call 1-800-25-LEXUS (1-800-255-3987) or push the “SOS” button in your vehicle for further subscription details.

## Lexus Enform with Safety Connect (If Equipped)

Lexus Enform and Safety Connect are subscription-based telematics services that use Global Positioning System (GPS) data, embedded cellular technology and XM<sup>®</sup> satellite data services to provide safety and security as well as convenience features to subscribers.

Lexus Enform and Safety Connect services are supported by Lexus' designated response center, which operates 24 hours per day, 7 days per week.

Lexus Enform service is available by subscription on select, telematics hardware-equipped vehicles.

For details, refer to the "Owner's Manual" and "Navigation System Owner's Manual".

### n Services

---

► **With an active Lexus Enform subscription, the following features are available:**

#### 1 **Safety Connect features** (→P.59)

- Automatic collision notification<sup>\*1</sup>
- Stolen vehicle location
- Emergency assistance button (SOS)
- Enhanced Roadside assistance

#### 1 **Destination Assist**

Destination Assist provides you with live assistance for finding destinations via the Lexus Enform response center. You can request either a specific business, address, or ask for help locating your desired destination by category, such as restaurants, gas stations, shopping centers or other points of interest (POI).

After you tell the agent your choice of destination, its coordinates are sent wirelessly to your vehicle's navigation system.

#### 1 **eDestination**

With the eDestination feature, you can go online, via the Lexus.com owner's Web site, to select and organize destinations of your choice and then wirelessly send them to your vehicle's navigation system.

You can store up to 200 locations online to access and update at any time.

Your locations can be organized into up to 20 personalized folders.

You must first go online at [www.lexus.com](http://www.lexus.com) and go to the "Owners" section where you will need to register and log in. After this, you can create your personalized folders containing the locations you wish to send to your vehicle. (See Lexus Enform Guide for more information.)

#### 1 **XM<sup>®</sup> Sports and Stocks<sup>\*2</sup>**

XM<sup>®</sup> Sports and Stocks is a service included with XM<sup>®</sup> satellite radio subscriptions for Lexus Enform vehicles. With this service, you can receive updates via the navigation system on your personally selected sports teams and stocks.

### 1 XM NavWeather™\*3

The subscription-based XM NavWeather™ service allows the navigation system to display weather information on the map.

### 1 XM® NavTraffic\*3

The subscription-based XM® NavTraffic service allows the navigation system to display traffic information on the map.

► **The following navigation-based Lexus Enform features are available without a subscription:**

#### 1 Lexus Insider

Lexus Insider is an optional service that can send audio messages, or articles, to participating owner's vehicles via the navigation system. Potential Lexus Insider subjects might include, for example, Lexus vehicle technology tips, updates on regional Lexus events, or audio excerpts from Lexus Magazine articles. Up to 20 articles can be stored at a time.

#### 1 Voice Command

The voice command system enables you to operate the navigation system, audio system and hands-free system by giving a command.

\*1: U.S. Patent No. 7,508,298 B2

\*2: Available at no extra charge with an active XM® satellite radio subscription.

\*3: Available via separate XM® subscription(s).

## n Subscription

---

After you have signed the Telematics Subscription Service Agreement and are enrolled, you can begin receiving services. A variety of subscription terms is available for purchase. Contact your Lexus dealer, call 1-800-25-LEXUS (1-800-255-3987), or push the "Destination Assist" button in your vehicle for further subscription details. XM NavTraffic® and XM NavWeather™ require separate XM® subscription(s). XM® Sports and Stocks is available with an XM® Satellite Radio subscription. After a 90-day free trial, you must set up the appropriate XM® subscription(s) to continue receiving these services.

## Door Locks

### n Locking the vehicle from inside

---



#### ► Inside lock button

- 1 Locks
- 2 Unlocks



#### ► Door lock switches

Operates all door locks.

- 1 Locks
- 2 Unlocks

### n Locking the vehicle from outside

---

Using the entry function or wireless remote control (→P.7, 8)

### n Rear door child-protector lock

---



Pushing down the switch prevents the rear doors from being opened from the inside.

Always set the child protector locks when children are seated in the rear seat.

## Power Windows

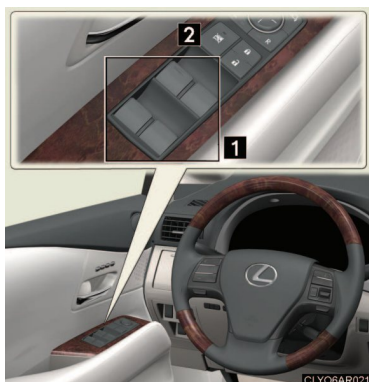

### 1 Power window switches

To open: press the switch.

To close: pull the switch up.

Fully pulling up and releasing the switches causes the windows to close fully. Fully pressing down and releasing the switches causes the windows to open fully.

### 2 Window lock switch

The window lock switch disables the operation of passenger window switches.

## Moon Roof (If Equipped)

### n Opening and closing

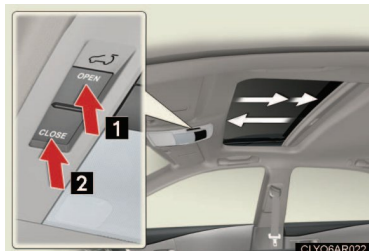

### 1 Opens

The moon roof stops slightly before the fully opened position.

To fully open, press the switch again.

### 2 Closes

To stop partway, press the switch lightly.

### n Tilt up and down

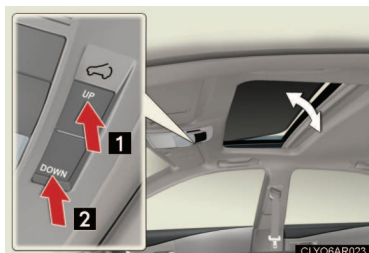

### 1 Tilts up

### 2 Tilts down

To stop partway, press the switch lightly.



## Back Door

### n Back door opener button

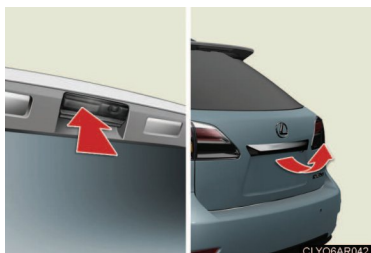

To open the back door, push up the opener button and raise the door.

### n Power back door switches (with power back door)



#### ► Instrument panel

To open or close the back door, press the switch.

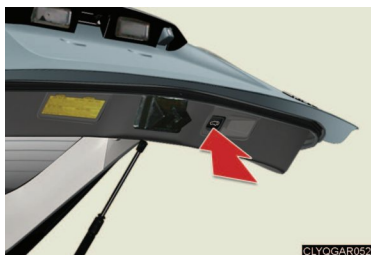

#### ► Back door

To close the back door, press the switch.

#### ► Wireless remote control (→P.7)

## n Back door closer (with power back door)

If the back door is left slightly open, it will close automatically.

## n Turning the power back door system on and off (with power back door)

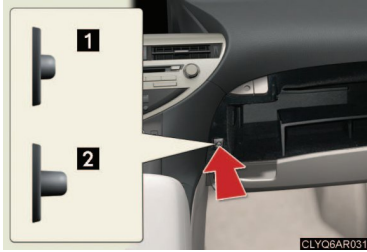

To disable the system, turn off the main switch in the glove box.

1 On

2 Off

When the power back door system is disabled, the back door cannot be opened using the wireless remote control or power back door switch.

## Fuel Tank Cap

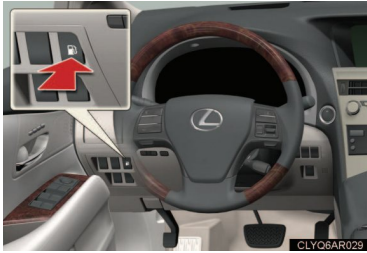

1 Press the fuel filler door opener.

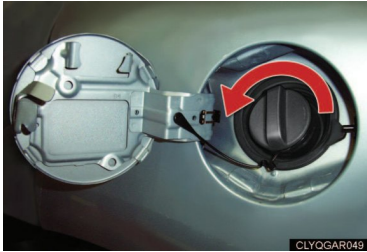

2 Slowly remove the cap by turning it counter-clockwise.

After the cap is removed, it can be hung on the inside of the fuel filler door.

## What to do if ...

### List of Warning/Indicator Lights

Stop the vehicle immediately. Continuing to drive the vehicle may be dangerous.

**BRAKE**

(U.S.A.)

Brake system warning light



(Canada)

Stop the vehicle immediately.



Charging system warning light

Have the vehicle inspected immediately.



(U.S.A.)

Malfunction indicator lamp



(Canada)



SRS warning light



(U.S.A.)

"ABS" warning light



(Canada)



Electric power steering system warning light



Pre-collision system warning light\*<sup>1</sup>



(Flashing and then continuously on)

Tire pressure warning light

Follow the correction procedures.



Open door warning light



Low fuel level warning light



(On the instrument panel)

Driver's seat belt reminder light



(On the center panel)

Front passenger's seat belt reminder light



(Illuminate no flashing)

Tire pressure warning light\*<sup>2</sup>



Master warning light

For further information, refer to the Owner's Manual.

## See the Owner's Manual



Turn signal indicator



Headlight high beam indicator



Automatic high beam indicator<sup>\*1</sup>



Headlight indicator (U.S.A.)



Tail light indicator (Canada)



Front fog light indicator



"ECT SNOW" indicator



All-wheel drive lock indicator<sup>\*1</sup>



Cruise control indicator



Radar cruise control indicator<sup>\*1</sup>



Intuitive parking assist-sensor indicator<sup>\*1</sup>



"AFS OFF" indicator<sup>\*1</sup>



Slip indicator



VSC off indicator



Eco Driving Indicator Light



SRS airbag on-off indicator<sup>\*1</sup>



SRS airbag on-off indicator<sup>\*1</sup>

For further information, refer to the Owner's Manual.

<sup>\*1</sup>: If equipped

<sup>\*2</sup>: It also turn on due to natural causes such as natural air leaks or tire inflation pressure changes caused by temperature (the status of the full-sized spare tire, if equipped, is also checked). Adjust the tire inflation pressure.

## What to do if ...

### If the electronic key does not operate properly

#### n Unlocking and locking the doors

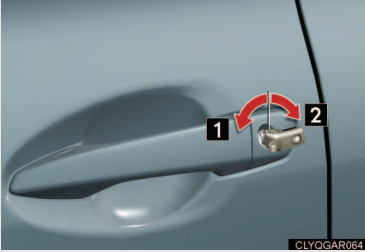

To unlock or lock the vehicle, use the mechanical key. (driver's door only) The mechanical key is stored inside the electronic key.

- 1 Locks
- 2 Unlocks

#### n Starting the engine



- 1 Depress the brake pedal.
- 2 Touch the Lexus emblem side of the electronic key to the "ENGINE START STOP" switch.
- 3 Press the "ENGINE START STOP" switch within 10 seconds of the buzzer, keeping the brake pedal depressed.

\*: If equipped

If the electronic key battery becomes depleted, replace it with a new battery. For instructions on replacing the battery, refer to the Owner's Manual. If you need further assistance, contact your Lexus dealer.

## If the engine doesn't start

Make sure that the correct operating procedures have been followed.

**Brake pedal**

Make sure that the brake pedal is firmly depressed when attempting to start the engine.

**Steering wheel lock**

Make sure that the steering wheel lock is released.

To release it, press the "ENGINE START STOP" switch while gently turning the wheel left or right.

If the engine still does not start, see the Owner's Manual for more information or contact your Lexus dealer.

### Electronic Key Alarm

The electronic key alarm uses an alarm and warning messages to indicate that the electronic key has been used improperly. Take appropriate measure in response to any warning messages that are displayed. In some cases, an alarm may sound without an accompanying warning message. If so, follow the correction procedure in the table below.

Alarm	Situation	Correction procedure
Exterior alarm sounds once for 10 seconds.	An attempt was made to lock the vehicle while a door was open.	Close all of the doors and lock the doors again.
Interior alarm pings continuously.	The "ENGINE START STOP" switch was turned to ACCESSORY mode while the driver's door was open (or the driver's door was opened while the "ENGINE START STOP" switch was in ACCESSORY mode).	Close the driver's door.
	The "ENGINE START STOP" switch was turned off while the driver's door was open.	Close the driver's door.









### Your Lexus dealer

Your Lexus dealer will provide quality maintenance and any other assistance you may require.

If there is not a Lexus dealer near you, please call the following number:

#### n U.S. OWNERS

l In the U.S. mainland or Canada:

Lexus Roadside Assistance

**1-800-25-LEXUS** or **1-800-255-3987** (Toll-Free)

l In Hawaii:

Servco Automotive Roadside Assistance/Customer Services

**1-800-25-LEXUS** or **1-800-255-3987** (Toll-Free)

#### n CANADIAN OWNERS

l In Canada or the U.S. mainland:

Lexus Roadside Assistance/Customer Service

**1-800-26-LEXUS** or **1-800-265-3987** (Toll-Free)

Please access our **websites** for further information.

l The U.S. mainland: **[www.lexus.com](http://www.lexus.com)**

l Hawaii: **[www.servcolexus.com](http://www.servcolexus.com)**

l Canada: **[www.lexus.ca](http://www.lexus.ca)**

©2010 TOYOTA MOTOR CORPORATION

All rights reserved. This material may not be reproduced or copied, in whole or in part, without the written permission of Toyota Motor Corporation.

# TABLE OF CONTENTS

<b>1</b>	<b>Before driving</b>	Adjusting and operating features such as door locks, mirrors, and steering column.
<b>2</b>	<b>When driving</b>	Driving, stopping and safe-driving information.
<b>3</b>	<b>Interior features</b>	Air conditioning and audio systems, as well as other interior features for a comfortable driving experience.
<b>4</b>	<b>Maintenance and care</b>	Cleaning and protecting your vehicle, performing do-it-yourself maintenance, and maintenance information.
<b>5</b>	<b>When trouble arises</b>	What to do if the vehicle needs to be towed, gets a flat tire, or is involved in an accident.
<b>6</b>	<b>Vehicle specifications</b>	Detailed vehicle information.
<b>7</b>	<b>For owners</b>	Reporting safety defects for U.S. owners and seat belt and SRS airbag instructions for Canadian owners.
	<b>Index</b>	Alphabetical listing of information contained in this manual.

**1 Before driving**

**1-1. Key information**  
 Keys ..... 26

**1-2. Opening, closing and locking the doors**  
 Smart access system with push-button start ..... 31  
 Wireless remote control ..... 43  
 Side doors ..... 47  
 Back door ..... 50

**1-3. Adjustable components (seats, mirrors, steering wheel)**  
 Front seats ..... 61  
 Rear seats ..... 66  
 Driving position memory ..... 70  
 Head restraints ..... 73  
 Seat belts ..... 75  
 Steering wheel ..... 83  
 Anti-glare inside rear view mirror ..... 85  
 Outside rear view mirrors ..... 87

**1-4. Opening and closing the windows and moon roof**  
 Power windows ..... 90  
 Moon roof ..... 93

**1-5. Refueling**  
 Opening the fuel tank cap ..... 97

**1-6. Theft deterrent system**  
 Engine immobilizer system ..... 101  
 Alarm ..... 103  
 Theft prevention labels (for U.S.A.) ..... 106

**1-7. Safety information**  
 Correct driving posture ..... 107  
 SRS airbags ..... 109  
 Front passenger occupant classification system ..... 122  
 Child restraint systems ..... 127  
 Installing child restraints ..... 131

**2 When driving**

**2-1. Driving procedures**  
 Driving the vehicle ..... 144  
 Engine (ignition) switch ..... 153  
 Automatic transmission ..... 159  
 Turn signal lever ..... 163  
 Parking brake ..... 164  
 Horn ..... 165

## 2-2. Instrument cluster

Gauges and meters .....	166
Indicators and warning lights.....	168
Multi-information display.....	173
Head-up display .....	179

## 2-3. Operating the lights and windshield wipers

Headlight switch.....	184
Automatic High Beam .....	189
Fog light switch .....	195
Windshield wipers and washer.....	197
Rear window wiper and washer.....	202
Headlight cleaner switch .....	203

## 2-4. Using other driving systems

Cruise control .....	204
Dynamic radar cruise control.....	208
Intuitive parking assist .....	220
Rear view monitor system (rear view mirror-attached type).....	227
Driving assist systems.....	231
All-wheel drive lock switch (AWD models) .....	237
Hill-start assist control.....	238
Pre-Collision System.....	240

## 2-5. Driving information

Utility vehicle precautions.....	244
Cargo and luggage.....	249
Vehicle load limits.....	253
Winter driving tips .....	254
Trailer towing.....	258
Dinghy towing .....	270

## 3 Interior features

### 3-1. Using the air conditioning system and defogger

Automatic air conditioning system.....	274
Rear window defogger switch .....	281
Windshield wiper de-icer .....	282

### 3-2. Using the audio system

Audio system .....	283
Using the radio.....	287
Using the CD player.....	297
Playing MP3 and WMA discs.....	307
Operating an iPod.....	317
Operating a USB memory.....	325
Optimal use of the audio system .....	334
Using the AUX port .....	337
Using the steering wheel audio switches .....	339

**3-3. Using the Bluetooth® audio system**

Bluetooth® audio system ..... 342

Using the Bluetooth® audio system ..... 345

Operating a Bluetooth® enabled portable player ..... 350

Setting up a Bluetooth® enabled portable player ..... 354

Bluetooth® audio system setup ..... 361

**3-4. Using the hands-free phone system (for mobile phones)**

Hands-free system for mobile phones ..... 362

Using the hands-free system (for mobile phones) ..... 366

Making a phone call ..... 374

Setting a mobile phone ..... 379

Security and system setup ..... 385

Using the phone book ..... 389

**3-5. Using the interior lights**

Interior lights list ..... 396

- Interior lights ..... 397
- Personal lights ..... 397

**3-6. Using the storage features**

List of storage features ..... 399

- Glove box ..... 400
- Bottle holders/door pockets ..... 401
- Cup holders ..... 402
- Console box ..... 404
- Auxiliary boxes ..... 406
- Under tray ..... 407

**3-7. Other interior features**

Sun visors ..... 408

Vanity mirrors ..... 409

Clock ..... 410

Outside temperature display ..... 411

Multi-display light control (vehicles without a navigation system) ..... 412

Power outlets ..... 413

Seat heaters and ventilators ..... 416

Armrest ..... 418

Coat hooks ..... 419

Floor mat ..... 420

Luggage compartment features ..... 421

Garage door opener ..... 426

Compass ..... 432

Safety Connect ..... 436

## 4 Maintenance and care

### 4-1. Maintenance and care

- Cleaning and protecting the vehicle exterior..... 444
- Cleaning and protecting the vehicle interior ..... 447

### 4-2. Maintenance

- Maintenance requirements.... 450
- General maintenance ..... 452
- Emission inspection and maintenance (I/M) programs ..... 456

### 4-3. Do-it-yourself maintenance

- Do-it-yourself service precautions..... 457
- Hood..... 460
- Positioning a floor jack..... 461
- Engine compartment..... 463
- Tires ..... 478
- Tire inflation pressure..... 487
- Wheels..... 491
- Air conditioning filter ..... 493
- Electronic key battery ..... 496
- Checking and replacing fuses ..... 498
- Headlight aim (discharge headlights) ..... 509
- Light bulbs..... 511

## 5 When trouble arises

### 5-1. Essential information

- Emergency flashers ..... 524
- If your vehicle needs to be towed ..... 525
- If you think something is wrong..... 531
- Fuel pump shut off system ..... 532
- Event data recorder..... 533

### 5-2. Steps to take in an emergency

- If a warning light turns on or a warning buzzer sounds... ..... 535
- If a warning message is displayed..... 545
- If you have a flat tire..... 564
- If the engine will not start ..... 577
- If the shift lever cannot be shifted from P ..... 579
- If you lose your keys ..... 580
- If the electronic key does not operate properly ..... 581
- If the battery is discharged ..... 584
- If your vehicle overheats ..... 587
- If the vehicle becomes stuck..... 590
- If your vehicle has to be stopped in an emergency..... 591

**6 Vehicle specifications**

**6-1. Specifications**  
 Maintenance data  
 (fuel, oil level, etc.)..... 594  
 Fuel information..... 606  
 Tire information..... 609

**6-2. Customization**  
 Customizable features..... 621

**6-3. Initialization**  
 Items to initialize ..... 630

**7 For owners**

Reporting safety defects  
 for U.S. owners..... 632

Seat belt instructions  
 for Canadian owners  
 (in French)..... 633

SRS airbag instructions  
 for Canadian owners  
 (in French)..... 636

**Index**

Abbreviation list..... 648

Alphabetical index ..... 650

What to do if... ..... 665



1

2

3

4

5

6

7

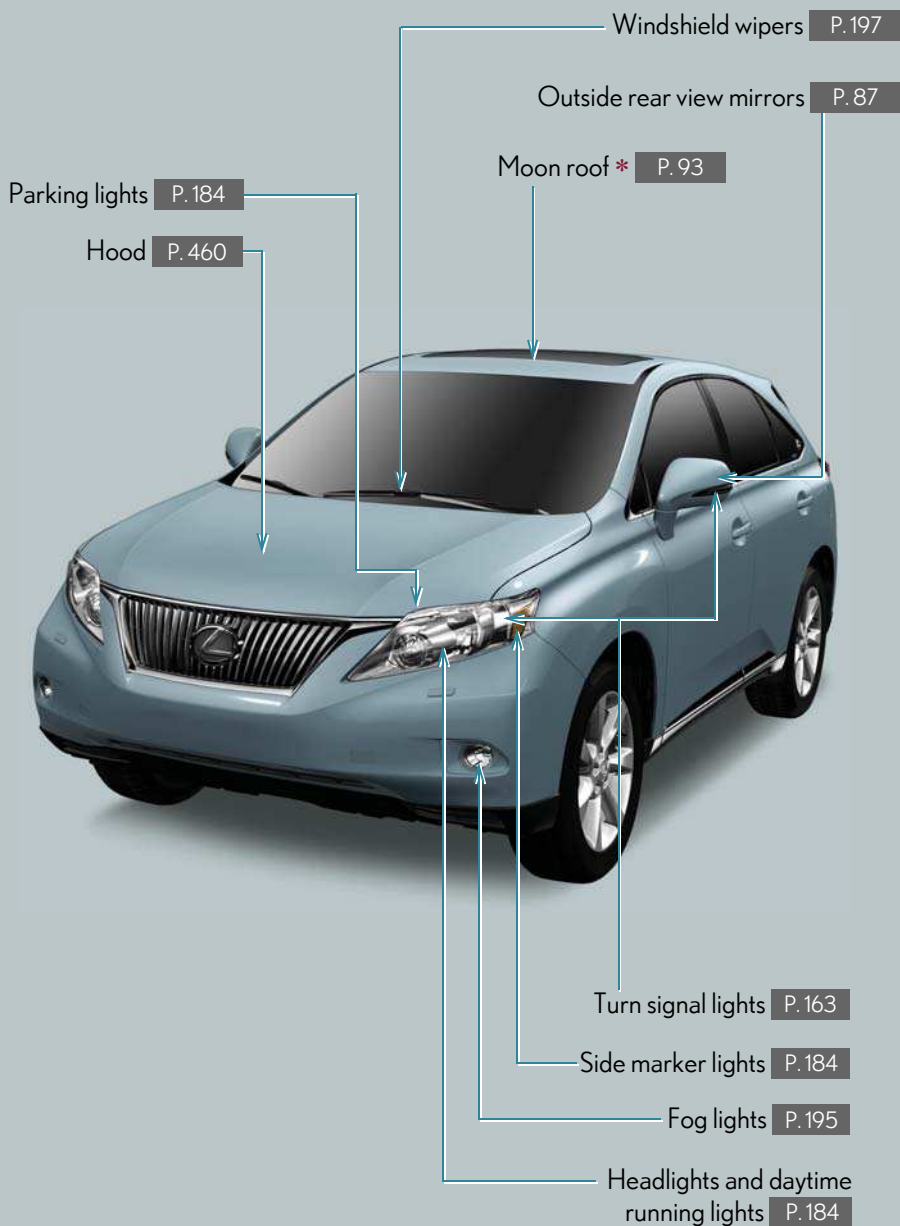

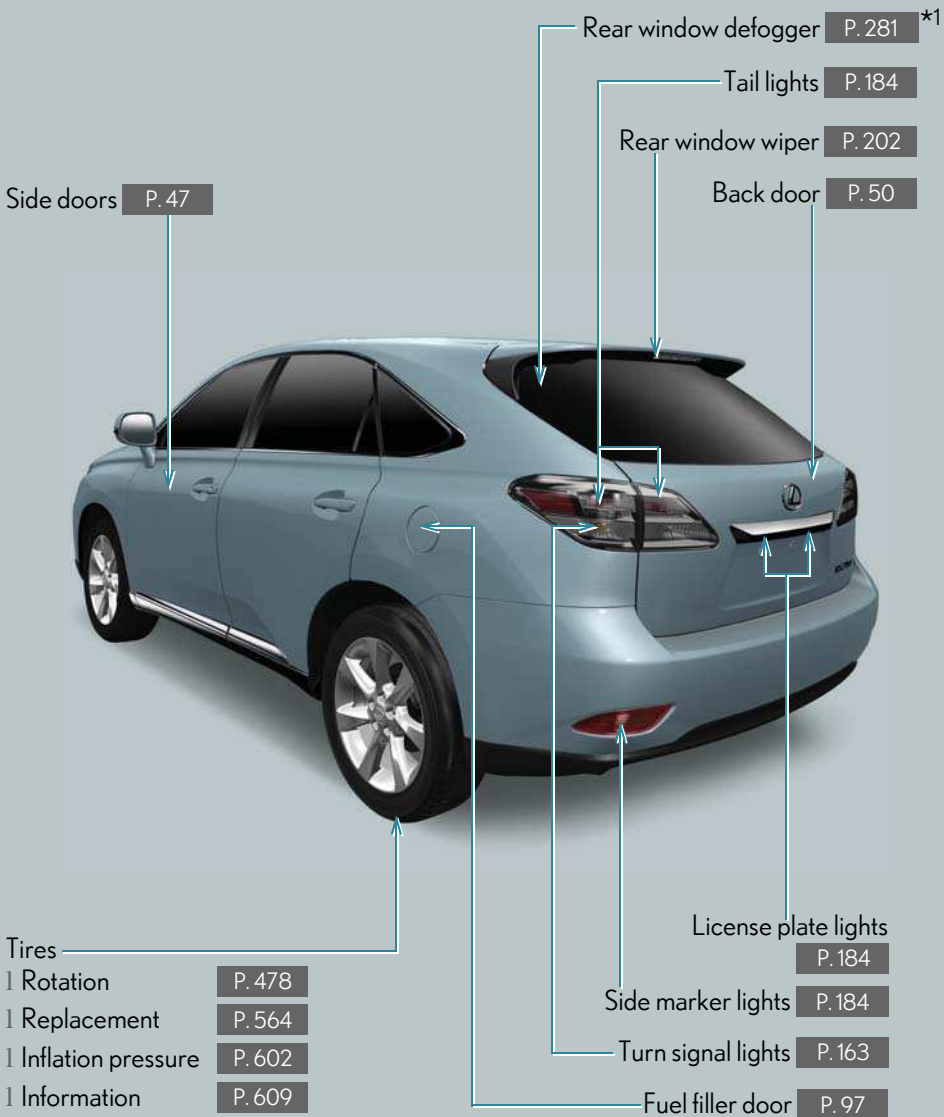

\*: If equipped

\*1: For vehicles with a navigation system, refer to the "Navigation System Owner's Manual".

# Pictorial index

# Interior

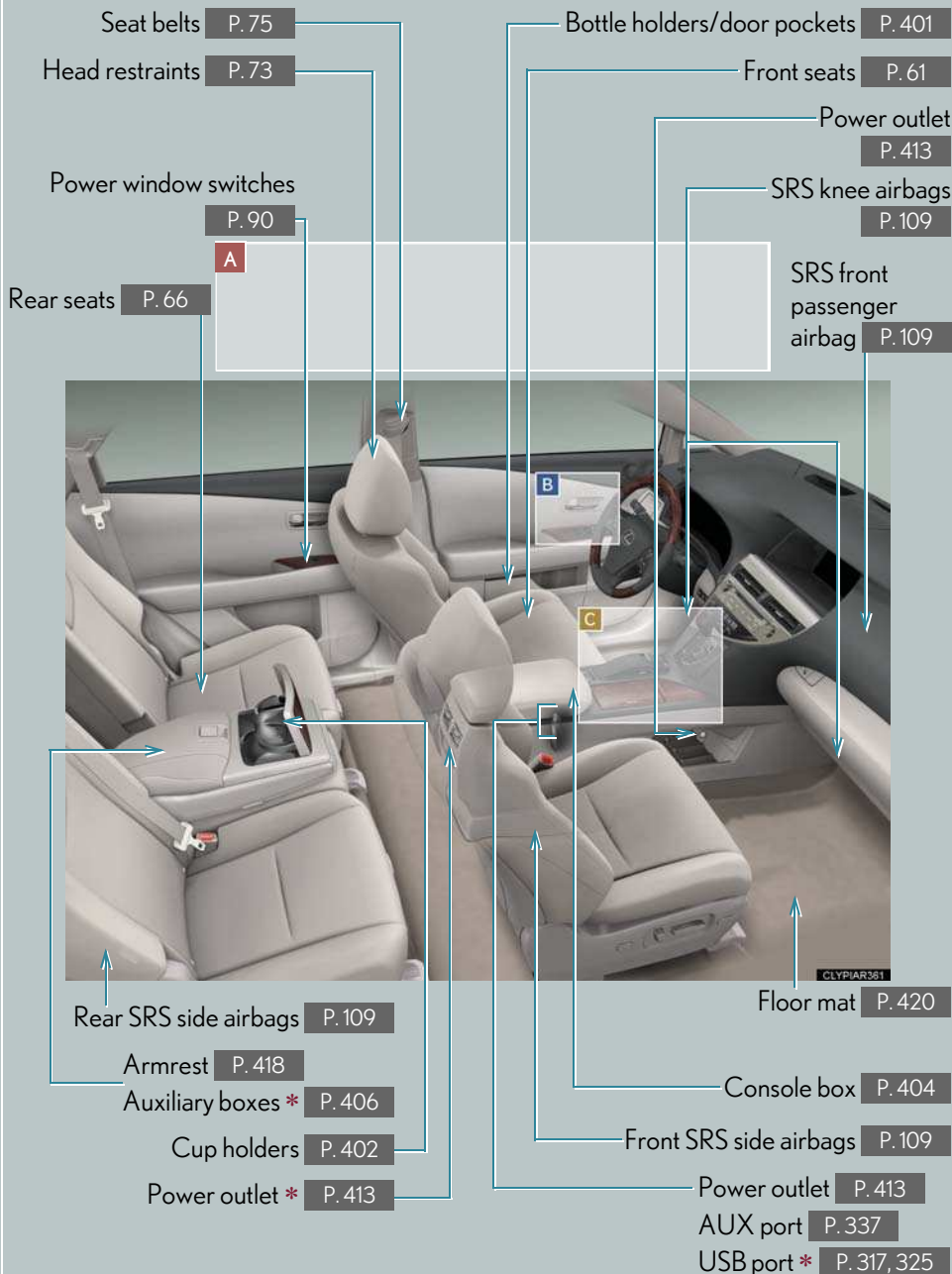

A

► Without "SOS" button

Rear view monitor system \* P. 227

Auxiliary boxes \* P. 406

Personal lights P. 397

Interior light P. 397

Interior light P. 397

Personal lights P. 397

SRS curtain shield airbags P. 109

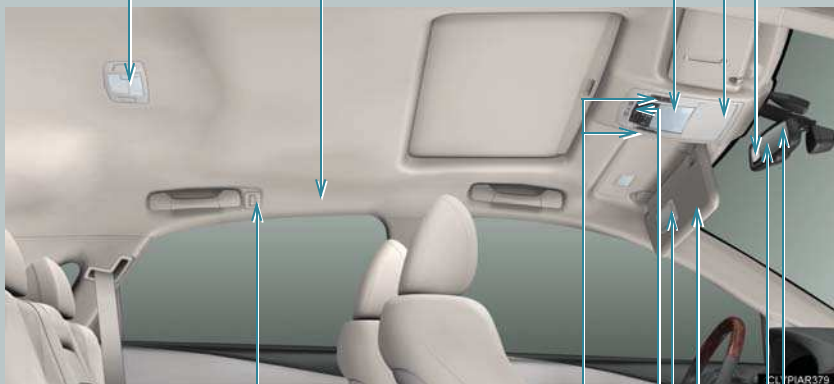

Coat hooks P. 419

Moon roof switches \* P. 93

Garage door opener switches P. 426

Vanity mirrors P. 409

Sun visors P. 408

Anti-glare inside rear view mirror P. 85

Compass \* P. 432

\*: If equipped

**A**

► With "SOS" button

Rear view monitor system \* P. 227

"SOS" button P. 436

Personal lights P. 397

Interior light P. 397

Interior light P. 397

Personal lights P. 397

SRS curtain shield airbags P. 109

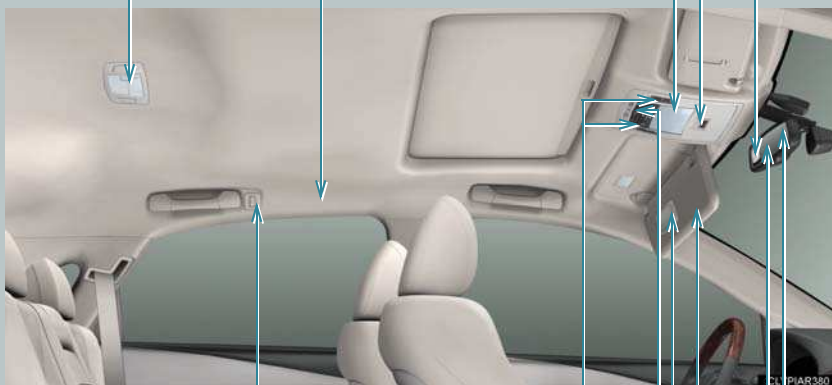

Coat hooks P. 419

Moon roof switches \* P. 93

Garage door opener switches P. 426

Vanity mirrors P. 409

Sun visors P. 408

Anti-glare inside rear view mirror P. 85

Compass \* P. 432

B

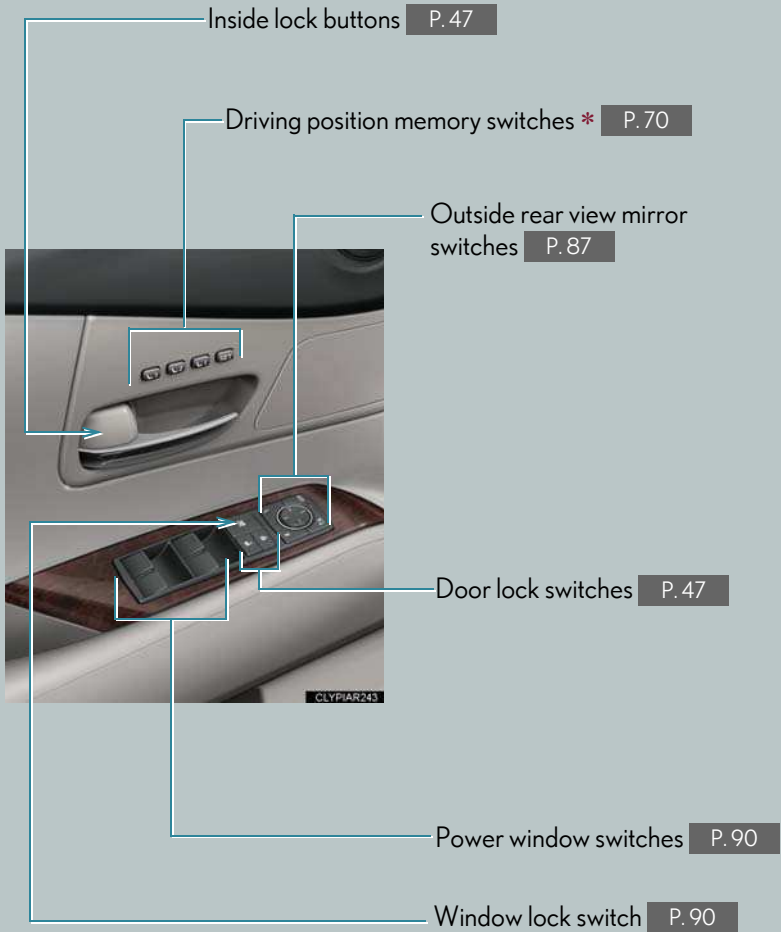

\*: If equipped

C

Automatic transmission shift lever P. 159

Shift lock override button P. 579

Remote Touch \*, \*2

Cup holders P. 402



VSC off switch P. 233

All-wheel drive lock switch \* P. 237

Seat heater switches \* /

Seat heater and ventilator switches \* P. 416

\*: If equipped

\*2: Refer to "Navigation System Owner's Manual".



# Pictorial index

# Instrument panel

Headlight switch P.184

Turn signal lever P.163

Fog light switch P.195

Glove box P.400

Power back door main switch \* P.52

Gauges and meters P.166

Multi-information display P.173

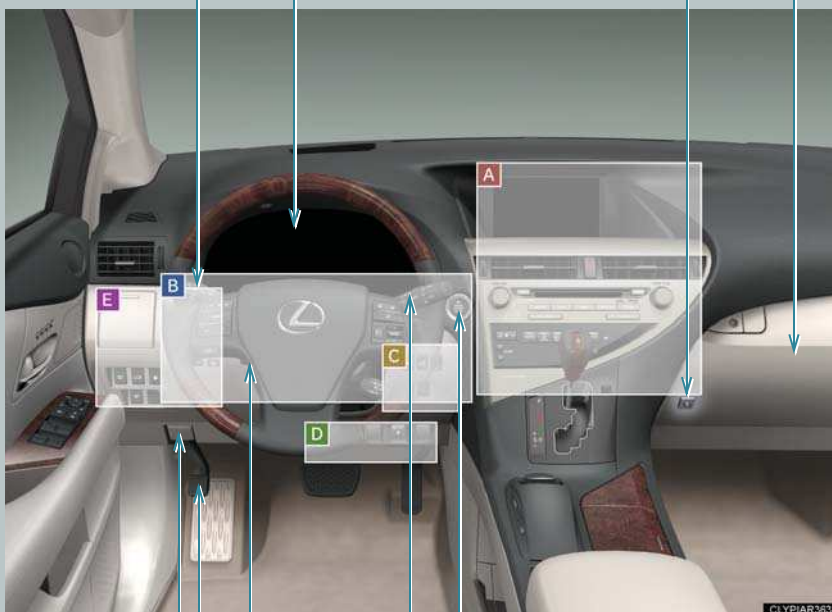

Engine (ignition) switch P.153

Windshield wiper and washer switch P.197

Rear window wiper and washer switch P.202

Tilt and telescopic steering control switch P.83

Parking brake pedal P.164

Hood lock release lever P.460

\*: If equipped

**A**

► With navigation system

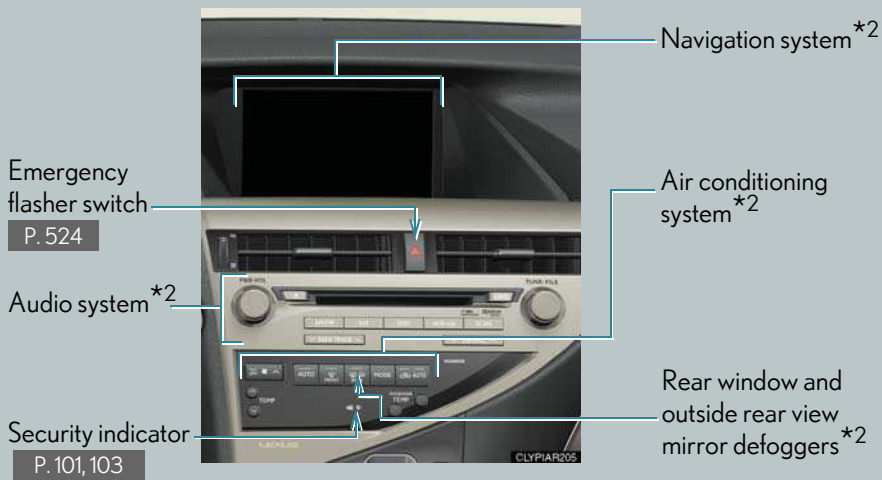

A

► Without navigation system

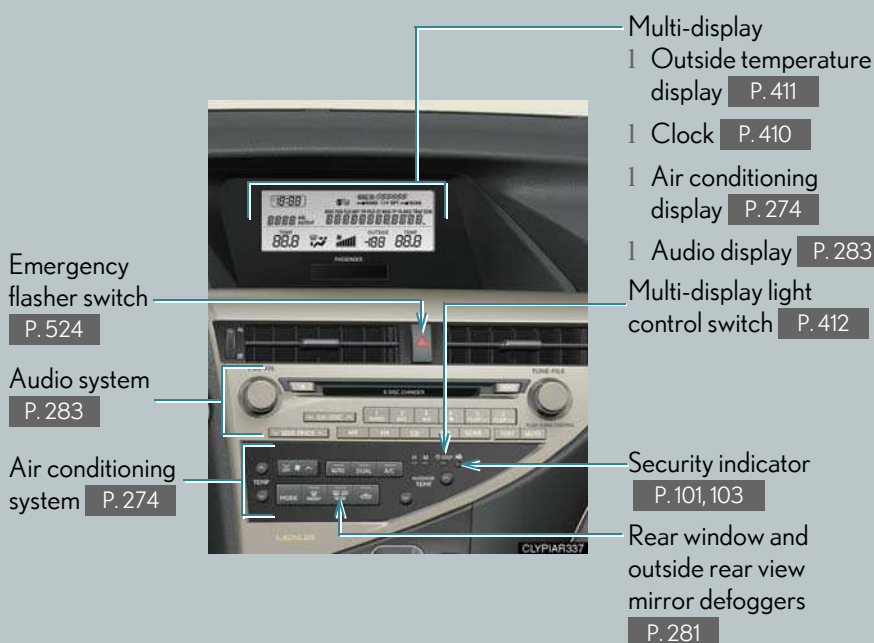

\*2: Refer to "Navigation System Owner's Manual".

**B**

Audio remote control switches P. 339 \*1

Talk switch \* P. 367 \*1

Telephone switches \* P. 367 \*1

Multi-information switch P. 173



Side camera switch \*, \*2

Horn P. 165

Distance switch \* P. 208

SRS driver airbag P. 109

Cruise control switch P. 204, 208

**C**

Display position adjustment switch \* P. 181

Head-up display main switch \* P. 181



Display contrast adjustment switch \* P. 181

D

Tire pressure warning reset switch P. 480



E

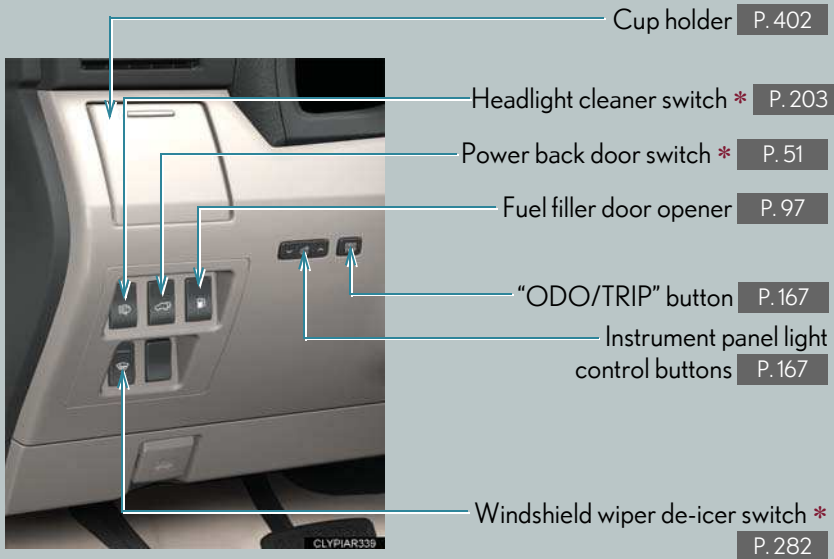

\*: If equipped

\*1: For vehicles with a navigation system, refer to the "Navigation System Owner's Manual".

\*2: Refer to "Navigation System Owner's Manual".



A

Power back door switch \* P. 50



B

Luggage compartment lights P. 53

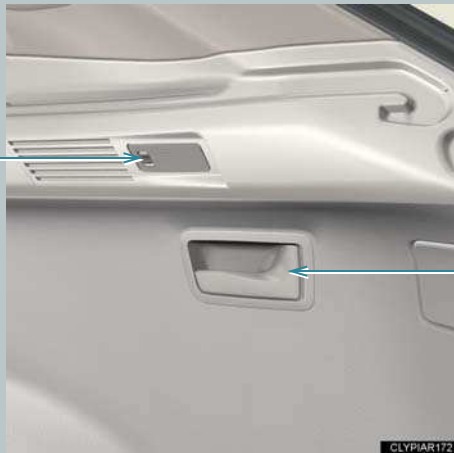

Rear seatback lock release levers P. 67

\*: If equipped

## For your information

### **Main Owner's Manual**

Please note that this manual applies to all models and explains all equipment, including options. Therefore, you may find some explanations for equipment not installed on your vehicle.

All specifications provided in this manual are current at the time of printing. However, because of the Lexus policy of continual product improvement, we reserve the right to make changes at any time without notice.

Depending on specifications, the vehicle shown in the illustrations may differ from your vehicle in terms of color and equipment.

### **Noise from under vehicle after turning off the engine**

Approximately five hours after the engine is turned off, you may hear sound coming from under the vehicle for several minutes. This is the sound of a fuel evaporation leakage check and, it does not indicate a malfunction.

### **Accessories, spare parts and modification of your Lexus**

A wide variety of non-genuine spare parts and accessories for Lexus vehicles are currently available in the market. You should know that Toyota does not warrant these products and is not responsible for their performance, repair, or replacement, or for any damage they may cause to, or adverse effect they may have on, your Lexus vehicle.

This vehicle should not be modified with non-genuine Lexus products. Modification with non-genuine Lexus products could affect its performance, safety or durability, and may even violate governmental regulations. In addition, damage or performance problems resulting from the modification may not be covered under warranty.

### **Installation of a mobile two-way radio system**

As the installation of a mobile two-way radio system in your vehicle could affect electronic systems such as the multiport fuel injection system/sequential multiport fuel injection system, cruise control system, anti-lock brake system, SRS airbag system and seat belt pretensioner system, be sure to check with your Lexus dealer for precautionary measures or special instructions regarding installation.



## Scrapping of your Lexus

The SRS airbag and seat belt pretensioner devices in your Lexus contain explosive chemicals. If the vehicle is scrapped with the airbags and seat belt pretensioners left as they are, this may cause an accident such as fire. Be sure to have the systems of the SRS airbag and seat belt pretensioner removed and disposed of by a qualified service shop or by your Lexus dealer before you scrap your vehicle.

## Perchlorate Material

Special handling may apply, See [www.dtsc.ca.gov/hazardouswaste/perchlorate](http://www.dtsc.ca.gov/hazardouswaste/perchlorate).

Your vehicle has components that may contain perchlorate. These components may include airbag, seat belt pretensioners, and wireless remote control batteries.

### CAUTION

#### **n General precautions while driving**

**Driving under the influence:** Never drive your vehicle when under the influence of alcohol or drugs that have impaired your ability to operate your vehicle. Alcohol and certain drugs delay reaction time, impair judgment and reduce coordination, which could lead to an accident that could result in death or serious injury.

**Defensive driving:** Always drive defensively. Anticipate mistakes that other drivers or pedestrians might make and be ready to avoid accidents.

**Driver distraction:** Always give your full attention to driving. Anything that distracts the driver, such as adjusting controls, talking on a cellular phone or reading can result in a collision with resulting death or serious injury to you, your occupants or others.

#### **n General precaution regarding children's safety**

Never leave children unattended in the vehicle, and never allow children to have or use the key.

Children may be able to start the vehicle or shift the vehicle into neutral. There is also a danger that children may injure themselves by playing with the cigarette lighter, the windows, the moon roof, or other features of the vehicle. In addition, heat build-up or extremely cold temperatures inside the vehicle can be fatal to children.

## Symbols used throughout this manual

### Cautions & Notices

#### CAUTION

This is a warning against something which, if ignored, may cause injury to people. You are informed about what you must or must not do in order to reduce the risk of injury to yourself and others.

#### NOTICE

This is a warning against something which, if ignored, may cause damage to the vehicle or its equipment. You are informed about what you must or must not do in order to avoid or reduce the risk of damage to your Lexus and its equipment.

### Symbols used in illustrations



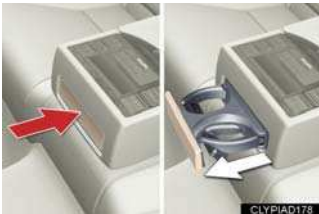

#### Safety symbol

The symbol of a circle with a slash through it means “Do not”, “Do not do this”, or “Do not let this happen”.



#### Arrows indicating operations

 Indicates the action (pushing, turning, etc.) used to operate switches and other devices.

 Indicates the outcome of an operation (e.g. a lid opens).

## 1-1. Key information

# Keys

The following keys are provided with the vehicle.

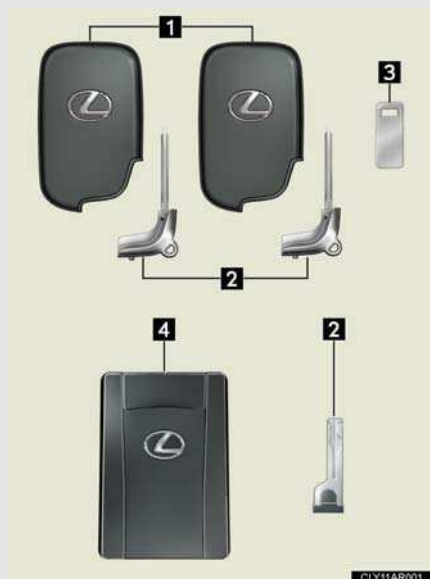

### 1 Electronic keys

- Operating the smart access system with push-button start (→P. 31)
- Operating the wireless remote control function (→P. 43)

### 2 Mechanical keys

### 3 Key number plate

### 4 Card key (electronic key) (if equipped)

Operating the smart access system with push-button start (→P. 31)

CLY11AR001

## Using the mechanical key

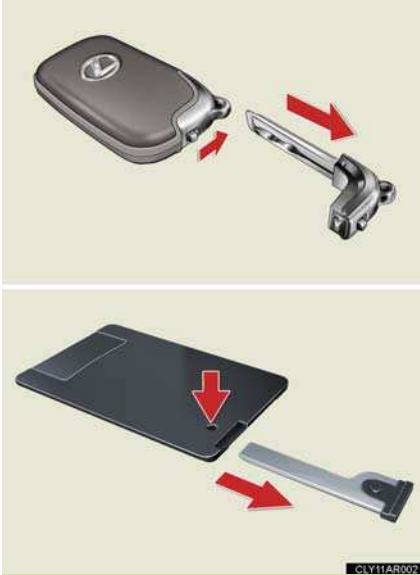

To take out the mechanical key:

Electronic keys: Slide the release lever and take the key out.

Card key: Press the lock release button and take the key out.

If the key cannot be inserted in a lock cylinder, turn it over and re-attempt to insert it. Mechanical keys with grooves on one side can be inserted in one direction only.

After using the mechanical key, store it in the electronic key. Carry the mechanical key together with the electronic key. If the electronic key battery is depleted or the entry function does not operate properly, you will need the mechanical key. (→P. 581)

### n Card key

- 1 The mechanical key that is stored inside the card key should be used only if a problem arises, such as when the key does not operate properly.
- 1 If it is difficult to take out the mechanical key, press down the lock release button using a pen tip etc. If it is still difficult to pull it out, use a coin etc.



- 1 To store the mechanical key in the card key, insert it while pressing the lock release button.



- 1 If the battery cover is not installed and the battery falls out or if the battery was removed because the key got wet, reinstall the battery with the positive terminal facing the Lexus emblem.

1 The card key is not waterproof.

### ▮ **When required to leave the vehicle's key with a parking attendant**

Lock the glove box as circumstances demand. (→P. 400)

Remove the mechanical key for your own use and provide the attendant with the electronic key only.

### ▮ **Key number plate**

Keep the plate in a safe place such as your wallet, not in the vehicle. In the event that a mechanical key is lost, a new key can be made at your Lexus dealer using the key number plate. (→P. 580)

### ▮ **When riding in an aircraft**

When bringing an electronic key onto an aircraft, make sure you do not press any buttons on the electronic key while inside the aircraft cabin. If you are carrying an electronic key in your bag etc, ensure that the buttons are not likely to be pressed accidentally. Pressing a button may cause the electronic key to emit radio waves that could interfere with the operation of the aircraft.

 NOTICE**n To prevent key damage**

Observe the following:

- l Do not drop the keys, subject them to strong shocks or bend them.
- l Do not expose the keys to high temperatures for a long period of time.
- l Do not get the keys wet or wash them in an ultrasonic washer etc.
- l Do not attach metallic or magnetic materials to the keys or place the keys close to such materials.
- l Do not disassemble the keys.
- l Do not attach a sticker or anything else to the surface of the electronic key.
- l Do not place the keys near objects that produce magnetic fields, such as TVs, audio systems, glass top ranges, or medical electrical equipment, such as low-frequency therapy equipment.

**n Carrying the electronic key on your person**

Carry the electronic key 3.9 in. (10 cm) or more away from electric appliances that are turned on.

**n In case of a smart access system with push-button start malfunction or other key-related problems**

Take your vehicle with all the electronic keys provided with your vehicle, including the card key, to your Lexus dealer.

**n When a vehicle key is lost**

If the key remains lost, the risk of vehicle theft increases significantly. Visit your Lexus dealer immediately with all remaining electronic keys and the card key that was provided with your vehicle.

### NOTICE

#### **n Precautions for handling the card key**

- I** Do not apply excess force when inserting the mechanical key to the card key. Doing so may damage the card key.
- I** If the battery or card key terminals get wet, the battery may corrode and the card key may stop working.  
If the key is dropped into water, or if drinking water etc. is spilled on the key, immediately remove the battery cover and wipe the battery and terminals. (To remove the battery cover, lightly grasp and pull it.) If the battery is corroded, have your Lexus dealer, replace the battery.
- I** Do not crush the battery cover or use a screwdriver to remove the battery cover. Forcibly removing the battery cover may bend or damage the key.
- I** If the battery cover is frequently removed, the battery cover may become loose.
- I** When installing the battery, make sure to check the direction of the battery. Installing the battery in the wrong direction may cause the battery to deplete rapidly.
- I** The surface of the card key may be damaged, or its coating may peel off in the following situations:
  - The card key is carried together with hard objects, such as coins and keys.
  - The card key is scraped with a sharp object, such as the tip of a mechanical pencil.
  - The surface of the card key is wiped with thinner or benzene.

## 1-2. Opening, closing and locking the doors

# Smart access system with push-button start

The following operations can be performed simply by carrying the electronic key (including the card key) on your person, for example in your pocket.

(The driver should always carry the electronic key.)

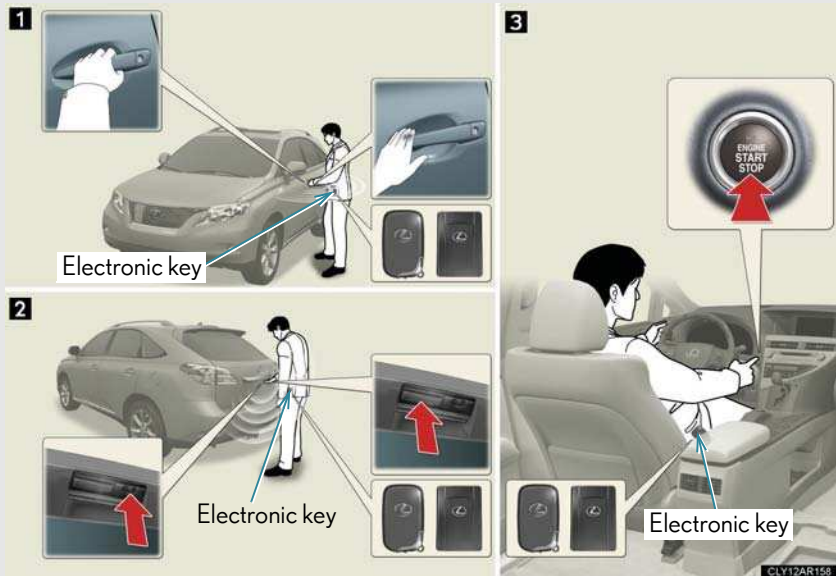

**1** Locks and unlocks the side doors (→P. 32)

**2** Locks and unlocks the back door (→P. 32)

**3** Starts the engine (→P. 153)



### Unlocking and locking the side doors (front door handles only)

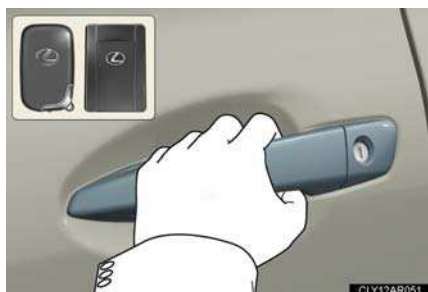

Grip the handle to unlock the door.

Make sure to touch the sensor on the back of the handle.

The doors cannot be unlocked for 3 seconds after the doors are locked.



Touch the lock sensor (the indentation on the upper part of the door handle) to lock the doors.

### Unlocking and locking the back door



Press the button to unlock the door.

The door cannot be unlocked for 3 seconds after the door is locked.



Press the button to lock the door.

1

Before driving

## Antenna location and effective range

### n Antenna location

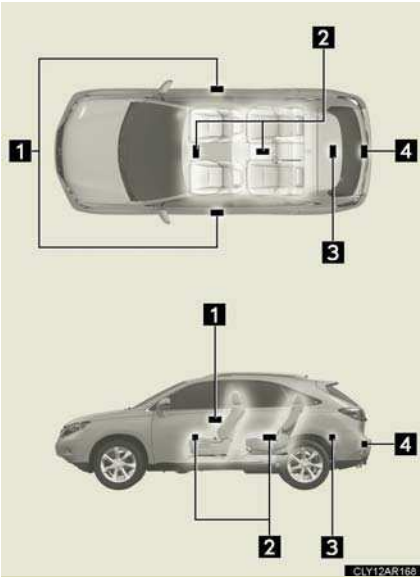

- 1 Antennas outside the cabin
- 2 Antennas inside the cabin
- 3 Antenna inside the luggage compartment
- 4 Antenna outside the luggage compartment

### n Effective range (areas within which the electronic key is detected)

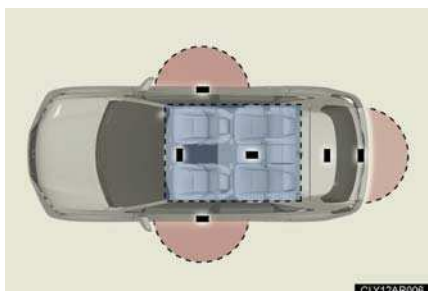

- When locking or unlocking the doors

The system can be operated when the electronic key is within about 2.3 ft. (0.7 m) of an outside door handle. (Only the doors detecting the key can be operated.)

- When starting the engine or changing “ENGINE START STOP” switch modes

The system can be operated when the electronic key is inside the vehicle.

---

### n Operation signals

A buzzer sounds and the emergency flashers flash to indicate that the doors have been locked/unlocked. (Locked: Once; Unlocked: Twice)

### n When the door cannot be locked by the lock sensor on the upper part of the door handle



Touch both lock sensors on the upper and lower part of the door handle simultaneously.

## ■ Alarms and warning indicators

A combination of exterior and interior alarms as well as warning messages shown on the multi-information display is used to prevent theft of the vehicle and accidents resulting from erroneous operation. Take appropriate measures in response to any warning message on the multi-information display. (→P. 545)

The following table describes circumstances and correction procedures when only alarms are sounded.

Alarm	Situation	Correction procedure
Exterior alarm sounds once for 10 seconds.	An attempt was made to lock the vehicle while a door was open.	Close all of the doors and lock the doors again.
Interior alarm pings repeatedly	The "ENGINE START STOP" switch was turned to ACCESSORY mode while the driver's door is open (The driver's door was opened when the "ENGINE START STOP" switch is in ACCESSORY mode.)	Close the driver's door.
	The "ENGINE START STOP" switch was turned off while the driver's door is open.	Close the driver's door.

## ■ Security feature

If a door is not opened within approximately 60 seconds after the vehicle is unlocked, the security feature automatically locks the vehicle again.

### n **Battery-saving function**

If the vehicle is parked for a long period of time, the battery-saving function is activated in order to prevent the vehicle battery from being discharged and the electronic key battery from being depleted.

1 In the following circumstances, unlocking the vehicle using the entry function may take longer than usual

- When the entry function has not been used for 5 days or more
- When the electronic key has been left within approximately 2 m (6 ft.) of the vehicle for 10 minutes or more

1 If the entry function has not been used for 14 days or more, the vehicle cannot be unlocked by a door other than the driver's door. To unlock the vehicle, grip the driver's door handle or use the wireless remote control or the mechanical key.

The system will resume operation when:

1 The vehicle is locked using the lock sensor.

1 The vehicle is locked/unlocked using the wireless remote control function. (→P. 43)

1 The vehicle is locked/unlocked using the mechanical key. (→P. 581)

### n **Conditions affecting operation**

The smart access system with push-button start uses weak radio waves. In the following situations, the communication between the electronic key and the vehicle may be affected, preventing the smart access system with push-button start, wireless remote control and immobilizer system from operating properly.

(Ways of coping: →P. 581)

1 When the electronic key battery is depleted

1 Near a TV tower, electric power plant, gas station, radio station, large display, airport or other facility that generates strong radio waves or electrical noise

1 When carrying a portable radio, cellular phone, cordless phone or other wireless communication devices

- 1 When the electronic key is in contact with, or is covered by the following metallic objects
  - Cards to which aluminum foil is attached
  - Cigarette boxes that have aluminum foil inside
  - Metallic wallets or bags
  - Coins
  - Hand warmers made of metal
  - Media such as CDs and DVDs
- 1 When multiple electronic keys are in the vicinity
- 1 When another wireless key (that emits radio waves) is being used nearby
- 1 When carrying the electronic key together with the following devices that emit radio waves
  - Another vehicle's electronic key or a wireless key that emits radio waves
  - Personal computers or personal digital assistants (PDAs)
  - Digital audio players
  - Portable game systems
- 1 If window tint with a metallic content or metallic objects are attached to the rear window

**n Note for the entry function**

- 1 Even when the electronic key is within the effective range (detection areas), the system may not operate properly in the following cases:
  - The electronic key is too close to the window or outside door handle, near the ground, or in a high place when the doors are locked or unlocked.
  - The electronic key is on the instrument panel, luggage cover or floor, or in the glove box.
- 1 As long as the electronic key is within the effective range, the doors may be locked or unlocked by anyone. However, only the doors detecting the electronic key can be used to unlock the vehicle.
- 1 The doors may lock or unlock if the electronic key is within the effective range and a large amount of water splashes on the door handle, such as in the rain or in a car wash. The doors will automatically be locked after approximately 60 seconds if a door is not opened and closed.
- 1 If the wireless remote control is used to lock the doors when the electronic key is near the vehicle, there is a possibility that the door may not be unlocked by the entry function. (Use the wireless remote control to unlock the doors.)

### n Notes for locking the doors

- 1 Touching the door lock sensor while wearing gloves may delay or prevent lock operation. Remove the gloves and touch the lock sensor again.
- 1 When the lock operation is performed using the lock sensor, recognition signals will be shown up to two consecutive times. After this, no recognition signals will be given.
- 1 If the door handle becomes wet while the electronic key is within the effective range, the door may lock and unlock repeatedly. Place the key in a position 6 ft. (2 m) or more separate from the vehicle while the vehicle is being washed. (Take care to ensure that the key is not stolen.)
- 1 If the electronic key is inside the vehicle and a door handle becomes wet during a car wash, a message may be shown on the multi-information display and a buzzer will sound outside the vehicle. To turn off the alarm, lock all the doors.
- 1 The lock sensor may not work properly if it comes into contact with ice, snow, mud, etc. Clean the lock sensor and attempt to operate it again, or use the lock sensor on the lower part of the door handle.
- 1 Fingernails may scrape against the door during operation of the door handle. Be careful not to injure fingernails or damage the surface of the door.

### n Notes for the unlocking function

- 1 Gripping the door handle when wearing a glove may not unlock the door.
- 1 A sudden approach to the effective range or door handle may prevent the doors from being unlocked. In this case, return the door handle to the original position and check that the doors unlock before pulling the door handle again.
- 1 If there is another electronic key in the detection area, it may take slightly longer to unlock the doors after the door handle is gripped.

### n When the vehicle is not driven for extended periods

- 1 To prevent theft of the vehicle, do not leave the electronic key within 6 ft. (2 m) of the vehicle.
- 1 The smart access system with push-button start can be deactivated in advance. (→P. 621)

### n **To operate the system properly**

Make sure to carry the electronic key when operating the system. Do not get the electronic key too close to the vehicle when operating the system from the outside of the vehicle.

Depending on the position and holding condition of the electronic key, the key may not be detected correctly and the system may not operate properly. (The alarm may go off accidentally, or the door lock prevention may not function.)

### n **If the smart access system with push-button start does not operate properly**

l Locking and unlocking the doors: Use the mechanical key. (→P. 581)

l Starting the engine: →P. 582

### n **Electronic key battery depletion**

l The standard battery life is 1 to 2 years. (The card key battery life is about a year and a half.)

l If the battery becomes low, an alarm will sound in the cabin when the engine stops. (→P. 556)

l As the electronic key always transmits radio waves, the battery will become depleted even if the electronic key is not used. The following symptoms indicate that the electronic key battery may be depleted. Replace the battery when necessary. (→P. 496)

- The smart access system with push-button start or the wireless remote control does not operate.
- The detection area becomes smaller.
- The LED indicator on the key surface does not turn on.

l To avoid serious deterioration, do not leave the electronic key within 3 ft. (1 m) of the following electrical appliances that produce a magnetic field:

- TVs
- Personal computers
- Cellular phones, cordless phones and battery chargers
- Recharging cellular phones or cordless phones
- Glass top ranges
- Table lamps

### n **When the electronic key battery is fully depleted**

→P. 496



### n Customization

Settings (e.g. smart access system with push-button start) can be changed.  
(Customizable features →P. 621)

### n Certification for the smart access system with push-button start

► For vehicles sold in Hawaii, Guam, Saipan and Puerto Rico

FCC ID: NI4TMLF8-6

FCC ID: HYQ14ACX

FCC ID: HYQ14AEB

FCC ID: HYQ13CZF

NOTE:

This device complies with part 15 of the FCC Rules. Operation is subject to the following two conditions: (1) This device may not cause harmful interference, and (2) this device must accept any interference received, including interference that may cause undesired operation.

FCC WARNING:

Changes or modifications not expressly approved by the party responsible for compliance could void the user's authority to operate the equipment.

► For vehicles sold in the mainland U.S.A.

FCC ID: NI4TMLF8-6

FCC ID: HYQ14ACX

FCC ID: HYQ14AEB

FCC ID: HYQ13CZF

FCC ID: HYQ14ADF

FCC ID: HYQ14AEF

FCC ID: HYQ13CZG

NOTE:

This device complies with Part 15 of the FCC Rules. Operation is subject to the following two conditions: (1) this device may not cause harmful interference, and (2) this device must accept any interference received, including interference that may cause undesired operation.

FCC WARNING:

Changes or modifications not expressly approved by the party responsible for compliance could void the user's authority to operate the equipment.

► For vehicles sold in Canada

NOTE:

Operation is subject to the following two conditions; (1) this device may not cause interference, and (2) this device must accept any interference, including interference that may cause undesired operation of the device.

L'utilisation de ce dispositif est autorisée seulement aux deux conditions suivantes: (1) il ne doit pas produire de brouillage, et (2) l'utilisateur du dispositif doit être prêt à accepter tout brouillage radioélectrique reçu, même si ce brouillage est susceptible de compromettre le fonctionnement du dispositif.

### CAUTION

#### **n** Caution regarding interference with electronic devices

**I** People with implanted pacemakers or cardiac defibrillators should keep away from the smart access system antennas. (→P. 33)

The radio waves may affect the operation of such devices. If necessary, the entry function can be disabled. Ask your Lexus dealer for details, such as the frequency of radio waves and timing of emitting the radio waves. Then, consult your doctor to see if you should disable the entry function.

**I** User of any electrical medical device other than implanted pacemakers and implanted cardiac defibrillators should consult the manufacturer of the device for information about its operation under the influence of radio waves.

Radio waves could have unexpected effects on the operation of such medical devices.

Ask your Lexus dealer for disabling the entry function.

# Wireless remote control

The wireless remote control can be used to lock and unlock the vehicle. It also opens and closes the back door.

► Vehicles without a power back door



**1** Locks all the doors

**2** Unlocks all the doors

Pressing the button unlocks the driver's door. Pressing the button again within 3 seconds unlocks the other doors.

**3** Opens the windows and moon roof (press and hold)

**4** Sounds the alarm (press and hold) (→P. 45)

### ► Vehicles with a power back door



**1** Locks all the doors

**2** Unlocks all the doors

Pressing the button unlocks the driver's door. Pressing the button again within 3 seconds unlocks the other doors.

**3** Opens the windows and moon roof (press and hold)

**4** Opens and closes the back door (press and hold)

**5** Sounds the alarm (press and hold) (→P. 45)

### ▮ Operation signals

Side doors: A buzzer sounds and the emergency flashers flash to indicate that the doors have been locked/unlocked. (Locked: Once; Unlocked: Twice)

Back door: A buzzer sounds and the emergency flashers flash twice to indicate that the back door is opening/closing.

Windows and moon roof: A buzzer sounds to indicate that the windows and moon roof are opening.

### ▮ Door lock buzzer

If an attempt to lock the doors is made when a door is not fully closed, a buzzer sounds continuously. Fully close the door to stop the buzzer, and lock the vehicle once more.

### n Security feature

→P. 35

### n Panic mode



When  is pressed for longer than about one second, an alarm will sound intermittently and the vehicle lights will flash to deter any person from trying to break into or damage your vehicle.

To stop the alarm, press any button on the electronic key.

### n Back door operation

The back door can be opened even if it is locked. Lock the back door again when you leave the vehicle. The back door will not lock automatically after it has been opened and then closed.

### n Alarm

Using the wireless remote control to lock the doors will set the alarm system. (→P. 103)

### n Reversing the operation of the power back door

Pressing the wireless remote control switch again while the power back door is operating will cause the operation to reverse.

### n Conditions affecting operation

→P. 36

### n If the wireless remote control does not operate properly

Locking and unlocking the doors: Use the mechanical key. (→P. 581)

### n Electronic key battery depletion

→P. 39

### ■ **When the electronic key battery is fully depleted**

→P. 496

### ■ **Customization**

Settings (e.g. door unlocking function) can be changed.  
(Customizable features →P. 621)

## 1-2. Opening, closing and locking the doors

### Side doors

The vehicle can be locked and unlocked using the entry function, wireless remote control or door lock switch.

#### n Entry function

→P. 32

#### n Wireless remote control

→P. 43

#### n Door lock switches



- 1 Locks all the doors
- 2 Unlocks all the doors

#### n Inside lock button

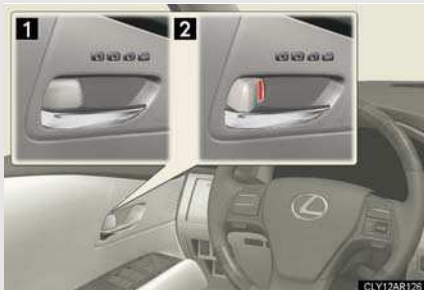

- 1 Locks the door
- 2 Unlocks the door

The front doors can be opened by pulling the inside handle even if the lock buttons are in the lock position.



### Locking the front doors from the outside without a key

**STEP 1** Move the inside lock button to the lock position.

**STEP 2** Close the door.

The door cannot be locked if the “ENGINE START STOP” switch is in ACCESSORY or IGNITION ON mode, or the electronic key is left inside the vehicle.

The key may not be detected correctly and the door may be locked.

### Rear door child-protector lock



The door cannot be opened from inside the vehicle when the lock is set.

These locks can be set to prevent children from opening the rear doors. Push down on each rear door switch to lock both rear doors.

#### n Impact detection door lock release system

In the event that the vehicle is subject to a strong impact, all the doors are unlocked. Depending on the force of the impact or the type of accident, however, the system may not operate.

#### n Using the mechanical key

The doors can also be locked and unlocked with the mechanical key. (→P. 581)

#### n If a wrong key is used

The key cylinder rotates freely to isolate inside mechanism.

#### n Customization

Settings (e.g. unlocking function using a key) can be changed. (Customizable features →P. 621)

 **CAUTION****n To prevent an accident**

Observe the following precautions while driving the vehicle.

Failure to do so may result in a door opening and an occupant falling out, resulting in death or serious injury.

**I** Always use a seat belt.

**I** Always lock all the doors.

**I** Ensure that all the doors are properly closed.

**I** Do not pull the inside handle of the doors while driving.

The doors may be opened and the passengers are thrown out of the vehicle and it may result in serious injury or death.

Be especially careful for the front doors, as the doors may be opened even if the inside lock buttons are in locked position.

**I** Set the rear door child-protector locks when children are seated in the rear seats.

**n When opening or closing a door**

Check the surroundings of the vehicle such as whether the vehicle is on an incline, whether there is enough space for a door to open and whether a strong wind is blowing. When opening or closing the door, hold the door handle tightly to prepare for any unpredictable movement.

## 1-2. Opening, closing and locking the doors

### Back door

The back door can be locked/unlocked and opened/closed by the following procedures.

#### **n** Locking and unlocking the back door

▶ Door lock switch

→P. 47

▶ Entry function

→P. 32

▶ Wireless remote control

→P. 43

#### **n** Opening the back door from outside the vehicle

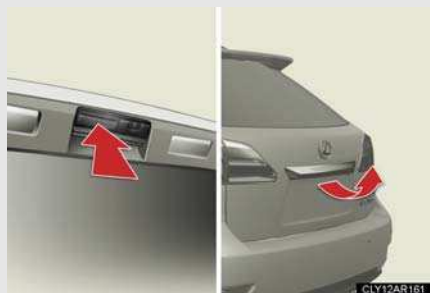

Raise the back door while pushing up the back door opener button.

## n Opening the back door from outside the vehicle (vehicles with a power back door)

### ▶ Using the back door opener button\*



When the back door is unlocked: Press the back door opener button.

When the back door is locked: While carrying the electronic key on your person, press and hold the back door opener button or press it twice.

\*: This setting must be customized at your Lexus dealer.

### ▶ Using the wireless remote control →P. 43

## n Opening the back door from inside the vehicle (vehicles with a power back door)



Press the switch to open/close.

Pressing the switch again while the power back door is operating will cause the operation to reverse.

### Power back door switch (vehicles with a power back door)



Press the switch to close the back door.

Pressing the switch again while the power back door is closing will cause it to open again.

### Canceling the power back door system (vehicles with a power back door)

Turn off the main switch in the glove box to disable the power back door system.

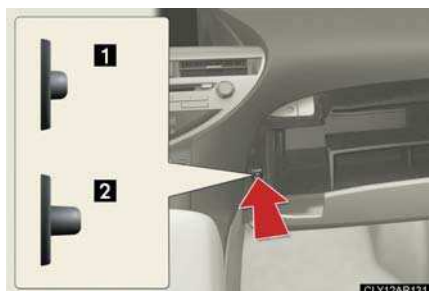

- 1 On
- 2 Off

The back door cannot be operated even with the wireless remote control or power back door switch.

### n The power back door can be operated when

- 1 The back door is unlocked. (Except for using the back door opener button\* or wireless remote control, when the power back door can be operated even if it is locked.)
  - 1 The power back door main switch is on.
  - 1 To open the power back door when the “ENGINE START STOP” switch is in IGNITION ON mode, the power back door main switch must be on, the vehicle speed must be lower than 1 mph (3 km/h) and the shift lever must be in P.
- \*: This setting must be customized at your Lexus dealer.

### n Back door handle

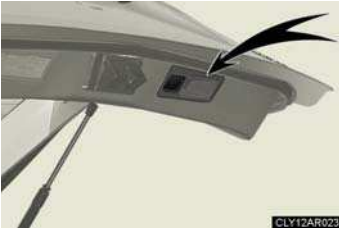

Use the back door handle when lowering the back door.

Do not close the back door fully while still holding the door handle as an injury may result.

### n Luggage compartment lights



The luggage compartment lights turn on when the back door is opened with the luggage compartment light switch on.

### n Back door closer (vehicles with a power back door)

In the event that the back door is left slightly open, the back door closer will automatically close it to the fully closed position.

- 1 The back door closer will operate regardless of the “ENGINE START STOP” switch mode.
- 1 The back door can be opened while the back door closer is operating by pressing the back door opener button.

### n **Power back door operation**

- l A buzzer sounds and the emergency flashers flash twice to indicate that the back door is opening/closing.
- l The back door can still be opened and closed manually, even when the power back door main switch is off.
- l Pressing the back door opener button while the power back door system is operating will cause the back door to switch to manual operation.
- l If anything obstructs the power back door while it is closing/opening, a buzzer will sound and the back door will automatically operate in the opposite direction.
- l If two or more successive attempts are made to close the back door, a buzzer will sound and the back door will switch to manual operation.

### n **Jam protection function (vehicles with a power back door)**



Sensors are attached to the left and right sides of the power back door. If these sensors detect an obstruction while the power back door is closing, the jam protection function will return the door to the fully open position.

### n **After the back door has been opened and then closed**

- l Lock the back door as the back door will not lock automatically.

**n If the back door opener is inoperative**

The back door can be opened from the inside.

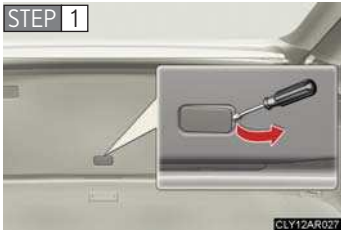

Remove the cover.



Move the lever.

► Vehicles with a power back door



► Vehicles without a power back door



**n After disconnecting the battery or changing a fuse**

To enable the power back door system to operate properly, perform the following procedures to initialize the system:

- 1 Unlock the back door using the door lock switch.
- 1 Lower the back door manually using the back door handle and fully close the back door by pushing it down.



### CAUTION

#### **n Caution while driving**

- 1** Keep the back door closed while driving.

If the back door is left open, it may hit near-by objects while driving or luggage may be unexpectedly thrown out, causing an accident.

In addition, exhaust gases may enter the vehicle, causing death or a serious health hazard. Make sure to close the back door before driving.

- 1** Before driving the vehicle, make sure that the back door is fully closed. If the back door is not fully closed, it may open unexpectedly while driving, causing an accident.

- 1** Never let anyone sit in the luggage compartment. In the event of sudden braking or a collision, they are susceptible to death or serious injury.

#### **n When children are in the vehicle**

Observe the following precautions.

Failure to do so may result in death or serious injury.

- 1** Do not leave children alone in the luggage compartment.

If a child is accidentally locked in the luggage compartment, they could have heat exhaustion.

- 1** Do not allow a child to open or close the back door.

Doing so may cause the back door to operate unexpectedly, or cause the child's hands, head, or neck to be caught by the closing back door, which may result in death or serious injury of the child.

#### **n Operating the back door**

Observe the following precautions.

Failure to do so may cause parts of the body to be caught, resulting in serious injury.

- 1** Remove any heavy loads, such as snow and ice, from the back door before opening it. Failure to do so may cause the back door fall closed again after it is opened.

- 1** When opening or closing the back door, thoroughly check to make sure the surrounding area is safe.

- 1** If anyone is in the vicinity, make sure they are safe and let them know that the back door is about to open or close.

- 1** Use caution when opening or closing the back door in windy weather as it may move abruptly in strong wind.

## ! CAUTION



1 The back door may fall if it is not opened fully. It is more difficult to open or close the back door on an incline than on a level surface, so beware of the back door unexpectedly opening or closing by itself. Make sure that the back door is fully open and secure before using the luggage compartment.



1 When closing the back door, take extra care to prevent your fingers etc. from being caught.

1 When closing the back door, make sure to press it lightly on its outer surface. If the back door strap is used to fully close the back door, it may result in hands or arms being caught.

1 Do not pull on the back door damper stay to close the back door, and do not hang on the back door damper stay.

Doing so may cause hands to be caught or the back door damper stay to break, causing an accident.

1 Do not attach any accessories other than genuine Lexus parts to the back door. Such additional weight on the back door may cause the back door to fall closed again after it is opened.

### n Back door closer



1 In the event that the back door is left slightly open, the back door closer will automatically close it to the fully closed position. It takes several seconds before the back door closer begins to operate. Be careful not to catch fingers or anything else in the back door, as this may cause bone fractures or other serious injuries.

1 Use caution when using the back door closer as it still operates when the power back door system is cancelled.

### CAUTION

#### **n Power back door**

Observe the following precautions when operating the power back door. Failure to do so may cause serious injury.

- I** Check the safety of the surrounding area to make sure there are no obstacles or anything that could cause any of your belongings to get caught.
- I** If anyone is in the vicinity, make sure they are safe and let them know that the back door is about to open or close.
- I** If the operating conditions of the power back door are no longer met, a buzzer may sound and the back door may stop opening or closing. The back door then has to be operated manually. Take extra care in this situation, as the back door may move abruptly.
- I** If the power back door main switch is turned off while the power back door is operating, the back door will change to manual operation. In this case, be careful as the back door may move suddenly.
- I** On an incline, the back door may fall after it opens automatically. Make sure the back door is fully open and secure.
- I** In the following situations, the power back door may detect an abnormality and automatic operation may be stopped. In this case, the back door has to be operated manually. Take extra care in this situation, as the stopped back door may suddenly fall, causing an accident.
  - When the back door contacts an obstacle
  - When the battery voltage suddenly drops, such as when the “ENGINE START STOP” switch is turned to IGNITION ON mode or the engine is started during automatic operation

 **CAUTION**

- I** Do not attach any accessories other than genuine Lexus parts to the back door. The power back door may not operate, causing itself to malfunction, or the back door may fall closed again after it is opened.
- I** In cases such as when replacing tires, make sure to turn off the power back door main switch. Failure to do so may cause the back door to operate unintentionally if the power back door switch is accidentally touched, resulting in hands and fingers being caught and injured.
- n** **Jam protection function (vehicle with a power back door)**

Observe the following precautions.  
Failure to do so may cause death or serious injury.

  - I** Be careful while the jam protection function is operating. Being hit by the back door may result in an injury.
  - I** If anything obstructs the power back door while it is closing, the jam protection function will cause the back door to automatically operate in the opposite direction. However, be careful not to jam body parts in the doorframe, as an injury may result.
  - I** Never use any part of your body to intentionally activate the jam protection function.
  - I** The jam protection function may not work if something gets caught just before the back door fully closes. Be careful not to catch fingers or anything else.
  - I** The jam protection function may not work depending on the shape of the object that is caught. Be careful not to catch fingers or anything else.
  - I** The sensors located on the right and left sides of the power back door detect obstructions and prevent them from becoming jammed in the door. Some objects may not be detected depending on their shape or how they are jammed. Be careful not to get fingers or other body parts caught in the back door while it is operating as this may result in a serious injury.

### NOTICE

#### **n Back door damper stays**

The back door is equipped with damper stays that hold the back door in place.

Observe the following precautions.

Failure to do so may cause damage to the back door damper stay, resulting in malfunction.



- 1 Do not attach any foreign objects, such as stickers, plastic sheets, or adhesives to the damper stay rod.
- 1 Do not touch the damper stay rod with gloves or other fabric items.
- 1 Do not attach any accessories other than genuine Lexus parts to the back door.
- 1 Do not place your hand on the damper stay or apply lateral forces to it.

#### **n To prevent back door closer malfunction**

- 1 Do not apply excessive force to the back door while the back door closer is operating.
- 1 If the back door is opened and closed repeatedly in a short amount of time, the back door closer may stop operating. In this case, manually open the back door once and wait for a while before attempting to close it again.

#### **n To prevent damage to the power back door**

- 1 Make sure that there is no ice between the back door and frame that would prevent movement of the back door. Operating the power back door when excessive load is present on the back door may cause a malfunction.
- 1 Do not apply excessive force to the back door while the power back door is operating.
- 1 Take care not to damage the sensors (installed on the right and left edges of the power back door) with a knife or other sharp object. If the sensor is disconnected, the power back door will not operate in automatic operation.
- 1 When manually closing the back door immediately after the power back door has been automatically opened fully, some resistance may be felt.

## 1-3. Adjustable components (seats, mirrors, steering wheel)

### Front seats

1

Before driving

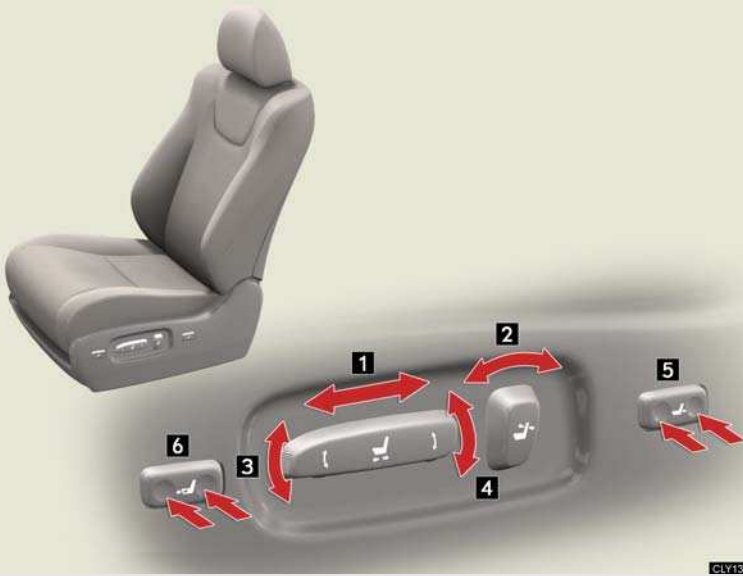

- 1 Seat position adjustment switch
- 2 Seatback angle adjustment switch
- 3 Seat cushion (front) angle adjustment switch
- 4 Vertical height adjustment switch
- 5 Lumbar support adjustment switch
- 6 Seat cushion length adjustment switch (if equipped)

#### Flattening the front seatbacks

##### n Before flattening the front seatbacks

Slide the rear seats as far back as possible. (→P. 66)

## n Flattening the front seatbacks

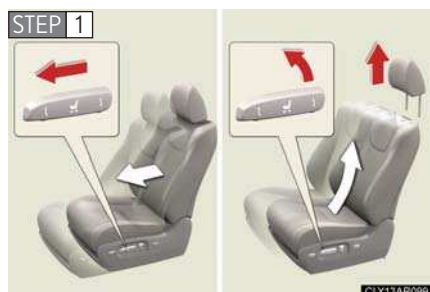

Move the front seat forward, raise the seat, and remove the head restraint (→P. 73).

After returning the seat to its original position, make sure to replace the head restraint.



Move the seatback angle adjustment switch backward to flatten the seatback.

### Power easy access system (vehicles with driving position memory)

When the driver enters and exits the vehicle, the driver's seat and steering wheel will automatically perform the following operations:

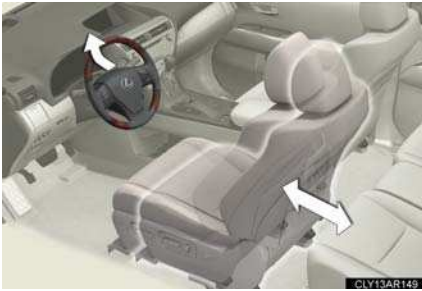

Exiting the vehicle: When all of the following actions have been performed, the steering wheel will move up and back to the point farthest away from the driver and the seat will move backward (auto away function):

- The shift lever has been shifted to P
- The “ENGINE START STOP” switch has been turned off
- The driver seat belt has been unfastened

Entering the vehicle: When either of the following actions has been performed, the steering wheel will move toward the driver and seat will move forward (auto return function):

- The “ENGINE START STOP” switch has been turned to ACCESSORY mode
- The driver seat belt has been fastened



## Active head restraints

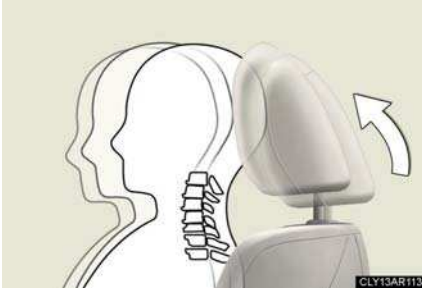

When the occupant's lower back presses against the seatback during a rear-end collision, the head restraint moves slightly forward and upward to help reduce the risk of whiplash on the seat occupant.

### n The auto away function for exiting the driver seat

If the seat is already close to the rearmost position, the auto away function may not operate when the driver exits the vehicle.

### n Active head restraints

Even small forces applied to the seatback may cause the head restraint to move. Pushing up a locked head restraint forcibly may appear the head restraint inner structure. These do not indicate problems.

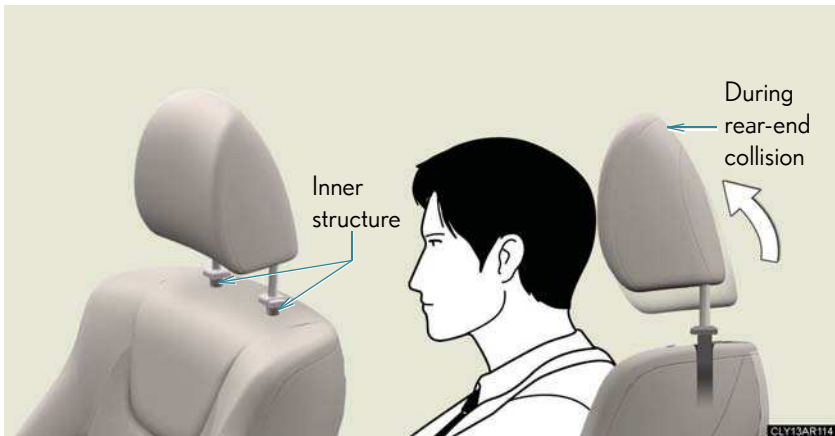

### n Customization

The distance that the driver's seat moves backward during the auto away function can be changed. (Customizable features →P. 621)

 **CAUTION**

**n Seat adjustment**

**I** To reduce the risk of sliding under the lap belt during a collision, do not recline the seat more than necessary.

If the seat is too reclined, the lap belt may slide past the hips and apply restraint forces directly to the abdomen, or your neck may contact the shoulder belt, increasing the risk of death or serious injury in the event of an accident.

**I** Adjustments should not be made while driving as the seat may unexpectedly move and cause the driver to lose control of the vehicle.

**n While driving**

Do not allow passengers to ride on the flattened seat.

## 1-3. Adjustable components (seats, mirrors, steering wheel)

### Rear seats

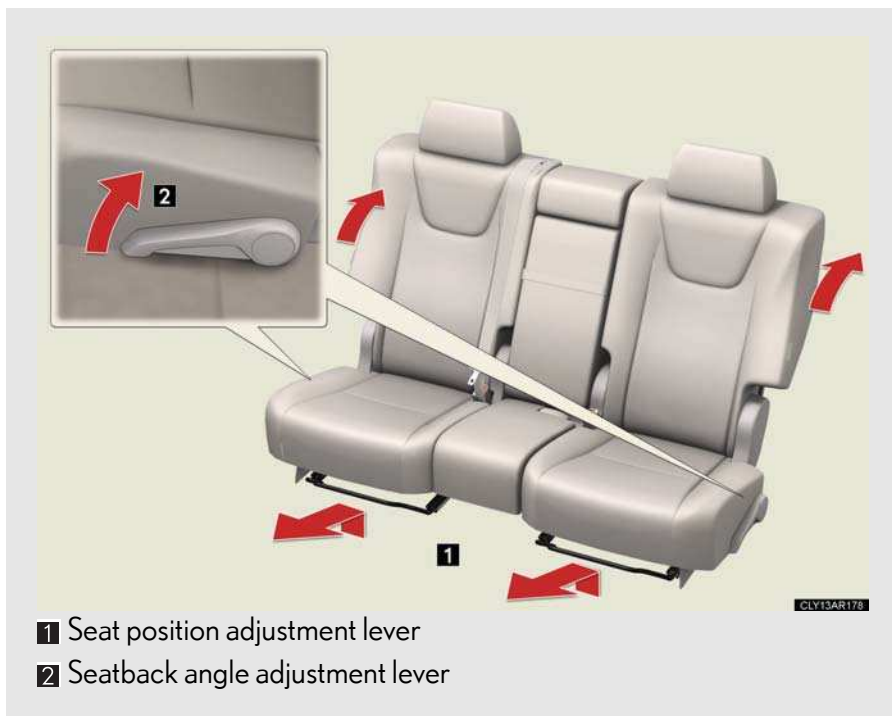

### Folding down the rear seatbacks

#### n Before folding down the rear seatbacks



Stow all the head restraints and the rear center seat belt buckle.



Stow the seat belts inside the rear seat side pockets.

When not in use, the seat belts should be stored inside the rear seat side pockets at all times.

**n** Folding down the rear seatbacks

► From inside

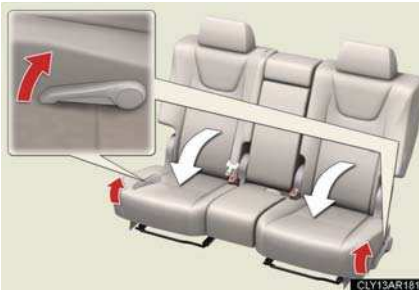

Pull the seatback angle adjustment lever.

To return the rear seatbacks to their original positions, lift them up until they lock.

► From outside



Pull the levers.

Left side lever: Folds down the left side rear seat

Right side lever: Folds down the right side and center rear seats

To return the rear seatbacks to their original positions, lift them up until they lock.

### n Folding down the rear center seatback



Pull the center seatback angle lever behind the seatback and fold the seatback down.

To return the rear center seatback to its original position, lift it up until it locks.

### ! CAUTION

#### n When folding the rear seatbacks down

Observe the following precautions. Failure to do so may result in death or serious injury.

- 1 Do not fold the seatbacks down while driving.
- 1 Do not fold seatbacks down while passengers are seated or luggage is placed on the seats.
- 1 Stop the vehicle on level ground, set the parking brake and shift the shift lever to P.
- 1 After folding the seatback, lightly move the seat back and forth to lock it in place.
- 1 Do not allow anyone to sit on a folded seatback or in the luggage compartment while driving.
- 1 Do not allow children to enter the luggage compartment.

#### n Seat adjustment

1 To reduce the risk of sliding under the lap belt during a collision, do not recline the seat more than necessary.

If the seat is too reclined, the lap belt may slide past the hips and apply restraint forces directly to the abdomen, or your neck may contact the shoulder belt, increasing the risk of death or serious injury in the event of an accident.

1 Adjustments should not be made while driving as the seat may unexpectedly move and cause the driver to lose control of the vehicle.

 CAUTION

**n After returning the rear seatback to the upright position**

Observe the following precautions. Failure to do so may result in death or serious injury.

- I** Make sure the seatback is securely locked by pushing it forward and rearward on the top.
- I** Check that the seat belts are not twisted or caught in the seatback.

 NOTICE

**n Stowing the center seat belt buckle**

Before folding down the rear seatbacks, stow the center seat belt buckle to prevent it from becoming caught in the seatbacks.

## 1-3. Adjustable components (seats, mirrors, steering wheel)

### Driving position memory\*

Your preferred driving position (the position of the driver's seat, steering wheel and outside rear view mirrors) can be memorized and recalled with the touch of a button. It is also possible to set this function to activate automatically when the doors are unlocked.

Three different driving positions can be entered into memory.

#### n Entering a position to memory

**STEP 1** Turn the "ENGINE START STOP" switch to IGNITION ON mode.

**STEP 2** Adjust the driver's seat, steering wheel and outside rear view mirrors to the desired positions.



Press the "SET" button, then within 3 seconds press button "1", "2" or "3" until the signal beeps.

If the selected button has already been preset, the previously recorded position will be overwritten.

#### n Recalling the memorized position

**STEP 1** Check that the shift lever is set in P.

**STEP 2** Turn the "ENGINE START STOP" switch to IGNITION ON mode.



Press button "1", "2" or "3" until the signal beeps to recall the desired position.

\*: If equipped

## Linking driving position memory with door unlock operation

Record your driving position to button “1”, “2” or “3” before performing the following:

Carry only the key (including the card key) to which you want to link the driving position. If 2 or more keys are in the vehicle, the driving position cannot be linked properly.

**STEP 1** Shift the shift lever to P and close the driver's door. Turn the “ENGINE START STOP” switch to IGNITION ON mode.

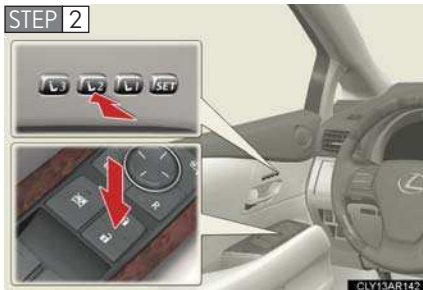

Press the desired button (“1”, “2” or “3”) to recall the position. Then, while keep pressing the button, press the driver's door lock switches (either lock or unlock) until the signal beeps.

The driving position is recalled when the driver's door is unlocked using the entry function or wireless remote control and the driver's door is opened.



### n **Operating the driving position memory after turning the “ENGINE START STOP” switch off**

Memorized positions (except for the steering wheel position) can be activated up to 180 seconds after the driver’s door is opened and another 60 seconds after it is closed again, even after turning the “ENGINE START STOP” switch off.

### n **Canceling the linked door unlock operation**

**STEP 1** Turn the “ENGINE START STOP” switch to IGNITION ON mode and close the driver’s door.

**STEP 2** While pressing the “SET” button, press the driver’s door lock switches (either lock or unlock) until the signal beeps.

### n **Stopping seat position operation part-way through**

Perform any of the following operations:

1 Press the “SET” button.

1 Press button “1”, “2” or “3”.

1 Adjust the seat using the switches (only cancels seat position recall).

1 Adjust the steering wheel using the tilt and telescopic steering control switch (only cancels steering wheel position recall).

### n **Correct seat position**

When the seat is in the most forward or most backward position, and the seat is being moved in those directions, the system may not correctly recognize the current position and the memorized position will not be correctly recalled.

### n **When the power easy access system (→P. 63) is activated**

If a seat position is memorized, the driver seat will move back the set distance (→P. 621) from that memorized position.

## CAUTION

### n **Seat adjustment caution**

Take care during seat adjustment so that the seat does not strike the rear passenger or squeeze your body against the steering wheel.

## Head restraints

Head restraints are provided for all seats.

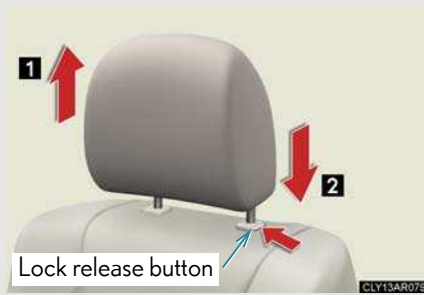

**1** Up

Pull the head restraints up.

**2** Down

Push the head restraint down while pressing the lock release button.

1

Before driving

### n Removing the head restraints



Pull the head restraint up while pressing the lock release button.

### n Installing the head restraints



Align the head restraint with the installation holes and push it down to the lock position.

Press and hold the lock release button when lowering the head restraint.

## 1-3. Adjustable components (seats, mirrors, steering wheel)

### n Adjusting the height of the head restraints (front seats)



Make sure that the head restraints are adjusted so that the center of the head restraint is closest to the top of your ears.

### n Adjusting the rear seat head restraints

Always raise the head restraints to the uppermost lock position during use.

#### CAUTION

##### n Head restraint precautions

Observe the following precautions regarding the head restraints. Failure to do so may result in death or serious injury.

- 1 Use the head restraints designed for each respective seat.
- 1 Adjust the head restraints to the correct position at all times.
- 1 After adjusting the head restraints, push down on them and make sure they are locked in position.
- 1 Do not drive with the head restraints removed.

# Seat belts

Make sure that all occupants are wearing their seat belts before driving the vehicle.

### n Correct use of the seat belts



- 1 Extend the shoulder belt so that it comes fully over the shoulder, but does not come into contact with the neck or slide off the shoulder.
- 1 Position the lap belt as low as possible over the hips.
- 1 Adjust the position of the seatback. Sit up straight and well back in the seat.
- 1 Do not twist the seat belt.

### n Fastening and releasing the seat belt

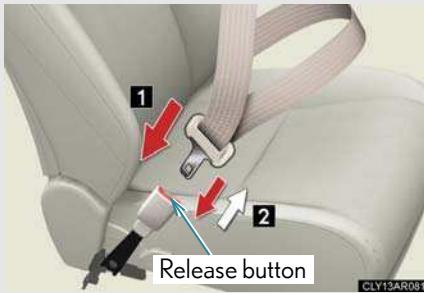

- 1 To fasten the seat belt, push the plate into the buckle until a click sound is heard.
- 2 To release the seat belt, press the release button.

### n Adjusting the seat belt shoulder anchor height (front seats)



1 Push the seat belt shoulder anchor down while pressing the release button.

2 Push the seat belt shoulder anchor up.

Move the height adjuster up and down as needed until you hear a click.

### Seat belt comfort guide (outside rear seats)

If the shoulder belt sits close to a person's neck, use the seat belt comfort guide.



Pull the comfort guide from the pocket.

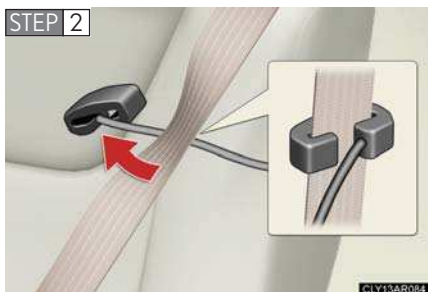

Slide the belt past the slot of the guide.

The elastic cord must be behind the seat belt.

STEP 3



Buckle the seat belt and position it comfortably.

### Seat belt pretensioners (front and outside rear seats)

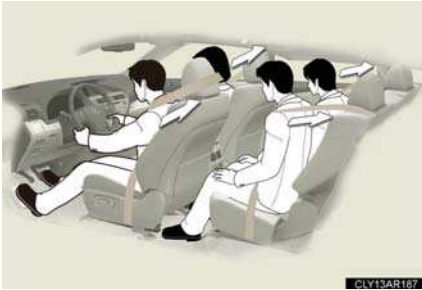

The pretensioner helps the seat belt to quickly restrain the occupant by retracting the seat belt when the vehicle is subjected to certain types of severe frontal collision.

The pretensioner may not activate in the event of a minor frontal impact, a side impact or a rear impact.

### Pre-collision seat belts (front seats of vehicles with pre-collision system)

If the pre-collision sensor detects that a collision is unavoidable, the pre-collision system will retract the seat belt, thus enhancing the effectiveness of the seat belt pretensioner in a crash.

The same will happen if the driver makes an emergency braking or loses control of the vehicle. (→P. 240)

#### n Emergency locking retractor (ELR)

The retractor will lock the belt during a sudden stop or on impact. It may also lock if you lean forward too quickly. To allow the belt to extend, retract the belt and then pull it slowly.

#### n Automatic locking retractor (ALR)

When a passenger's shoulder belt is completely extended and then retracted even slightly, the belt is locked in that position and cannot be extended. This feature is used to hold the child restraint system (CRS) firmly. To free the belt again, fully retract the belt and then pull the belt out once more. (→P. 131)

#### n Pregnant women

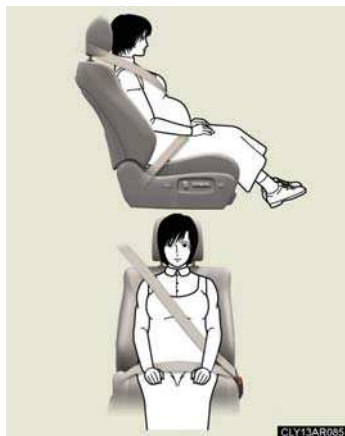

Obtain medical advice and wear the seat belt in the proper way. (→P. 75)

Women who are pregnant should position the lap belt as low as possible over the hips in the same manner as other occupants. Extend the shoulder belt completely over the shoulder and position the belt across the chest. Avoid belt contact over the round part of the abdominal area.

If the seat belt is not worn properly, not only the pregnant woman, but also the fetus could suffer death or serious injury as a result of sudden braking or a collision.

### n People suffering illness

Obtain medical advice and wear the seat belt in the proper way.

### n Child seat belt usage

The seat belts of your vehicle were principally designed for persons of adult size.

1 Use a child restraint system appropriate for the child, until the child becomes large enough to properly wear the vehicle's seat belt. (→P. 127)

1 When the child becomes large enough to properly wear the vehicle's seat belt, follow the instructions on P. 75 regarding seat belt usage.

### n Replacing the belt after the pretensioner has been activated

If the vehicle is involved in multiple collisions, the pretensioner will activate for the first collision, but will not activate for the second or subsequent collisions.

### n Seat belt extender



If your seat belts cannot be fastened securely because they are not long enough, a personalized seat belt extender is available from your Lexus dealer free of charge.



### CAUTION

#### **n Wearing a seat belt**

Observe the following precautions to reduce the risk of injury in the event of sudden braking, sudden swerving or an accident.

Failing to do so may cause death or serious injury.

- 1 Ensure that all passengers wear a seat belt.
- 1 Always wear a seat belt properly.
- 1 Each seat belt should be used by one person only. Do not use a seat belt for more than one person at once, including children.
- 1 Lexus recommends that children be seated in the rear seat and always use a seat belt and/or an appropriate child restraint system.
- 1 To achieve a proper seating position, do not recline the seat more than necessary. The seat belt is most effective when the occupants are sitting up straight and well back in the seats.
- 1 Do not wear the shoulder belt under your arm.
- 1 Always wear your seat belt low and snug across your hips.

#### **n Adjustable shoulder anchor**

Always make sure the shoulder belt is positioned across the center of your shoulder. The belt should be kept away from your neck, but not falling off your shoulder. Failure to do so could reduce the amount of protection in an accident and cause death or serious injuries in the event of a sudden stop, sudden swerve or accident. (→P. 76)

#### **n Seat belt pretensioners**

- 1 Do not place anything, such as a cushion, on the front passenger's seat. Doing so will disperse the passenger's weight, which prevents the sensor from detecting the passenger's weight properly. As a result, the seat belt pretensioner for the front passenger's seat may not activate in the event of a collision.
- 1 If the pretensioner has activated, the SRS warning light will come on. In that case, the seat belt cannot be used again and must be replaced at your Lexus dealer.

**! CAUTION****n Child restraint lock function belt precaution**

Do not allow children to play with the child restraint lock function belt. If the belt becomes twisted around a child's neck, it will not be possible to pull the belt out leading to choking or other serious injuries that could result in death.

If this occurs and the buckle cannot be unfastened, scissors should be used to cut the belt.

**n Seat belt damage and wear**

**I** Do not damage the seat belts by allowing the belt, plate, or buckle to be jammed in the door.

**I** Inspect the seat belt system periodically. Check for cuts, fraying, and loose parts. Do not use a damaged seat belt until it is replaced. Damaged seat belts cannot protect an occupant from death or serious injury.

**I** Ensure that the belt and tab are locked and the belt is not twisted. If the seat belt does not function correctly, immediately contact your Lexus dealer.

**I** Replace the seat assembly, including the belts, if your vehicle has been involved in a serious accident, even if there is no obvious damage.

**I** Do not attempt to install, remove, modify, disassemble or dispose of the seat belts. Have any necessary repairs carried out by your Lexus dealer. Inappropriate handling of the pretensioner may prevent it from operating properly, resulting in death or serious injury.

**n Using a seat belt comfort guide**

Failure to observe the following precautions could reduce the effectiveness of the seat belt in an accident, causing death or serious injury.

**I** Make sure the belt is not twisted and that it lies flat. The elastic cord must be behind the belt and the guide must be on the front.

**I** To reduce the chance of injury in case of a sudden stop, sudden swerve or accident while driving, remove and store the comfort guide in its pocket when it is not in use.

**I** Always make sure the shoulder belt is positioned across the center of the shoulder. The belt should be kept away from the neck, and should not fall off the shoulder.

 **CAUTION**

**n Using a seat belt extender**

- I** Do not wear the seat belt extender if you can fasten the seat belt without the extender.
- I** Do not use the seat belt extender when installing a child restraint system because the belt will not securely hold the child restraint system, increasing the risk of death or serious injury in the event of an accident.
- I** The personalized extender may not be safe on another vehicle, when used by another person, or at a different seating position other than the one originally intended.

 **NOTICE**

**n When using a seat belt extender**

When releasing the seat belt, press on the buckle release button on the extender, not on the seat belt.  
This helps prevent damage to the vehicle interior and the extender itself.

## 1-3. Adjustable components (seats, mirrors, steering wheel)

### Steering wheel

The steering wheel can be adjusted to a comfortable position.

Operating the switch moves the steering wheel in the following directions:



- 1 Up
- 2 Down
- 3 Away from the driver
- 4 Toward the driver

### Auto tilt away



When the “ENGINE START STOP” switch is turned off, the steering wheel returns to its stowed position by moving up and away to enable easier driver entry and exit.

Turning the “ENGINE START STOP” switch to ACCESSORY or IGNITION ON mode will return the steering wheel to the original position.

### **n The steering wheel can be adjusted when**

The “ENGINE START STOP” switch is in ACCESSORY or IGNITION ON mode\*.

\*: Vehicles with driving position memory: If the driver's seat belt is fastened, the steering wheel can be adjusted regardless of “ENGINE START STOP” switch mode.

### **n Automatic adjustment of the steering position (vehicles with driving position memory)**

A desired steering position can be entered to memory and recalled automatically by the driving position memory. (→P. 70)

### **n Notes for the auto tilt away function (vehicles with driving position memory)**

The auto tilt away function can only operate when the “ENGINE START STOP” switch has been turned off, the driver seat belt has been unfastened and the driver's seat movement (→P. 621) is in a setting other than off.

When the driver fastens the seat belt again, the steering wheel will return to the original position. (→P. 63)

## **! CAUTION**

### **n Caution while driving**

Do not adjust the steering wheel while driving.

Doing so may cause the driver to mishandle the vehicle and cause an accident, resulting in death or serious injury.

## 1-3. Adjustable components (seats, mirrors, steering wheel)

### Anti-glare inside rear view mirror

In automatic mode, sensors are used to detect the headlights of vehicles behind and the reflected light is automatically reduced.

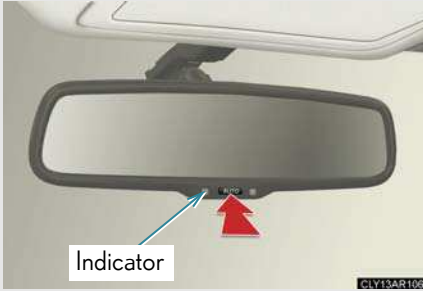

Turns automatic mode on/ off

The indicator comes on when automatic mode is turned on.

The mirror will revert to automatic mode each time the "ENGINE START STOP" switch is turned to IGNITION ON mode.

1

Before driving

### Adjusting the height of rear view mirror



Adjust the height of the rear view mirror by moving it up and down.

#### n To prevent sensor error



To ensure that the sensors operate properly, do not touch or cover them.

 **CAUTION**

**n Caution while driving**

Do not adjust the position of the mirror while driving.

Doing so may lead to mishandling of the vehicle and cause an accident, resulting in death or serious injury.

### Outside rear view mirrors

Mirror angle can be adjusted using the switch.

#### STEP 1



To select a mirror to adjust, press the switch.

- 1 Left
- 2 Right

Pressing the same switch again will put the switch in neutral.

#### STEP 2

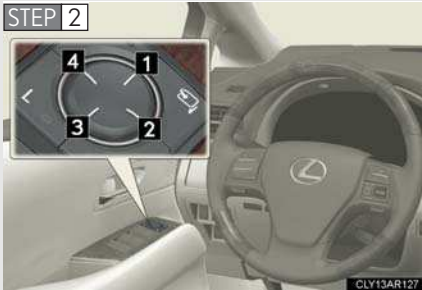

To adjust the mirror, press the switch.

- 1 Up
- 2 Right
- 3 Down
- 4 Left

### Manually folding and extending the mirrors



Push the mirror back in the direction of the vehicle's rear.



## Automatically folding and extending the mirrors (if equipped)

### n Using the switch



Press the switch to fold the mirrors.

Press it again to return them.

### n Setting automatic mode



Automatic mode allows the folding or extending of the mirrors to be linked to locking/unlocking of the doors.

Press the "AUTO" button to set automatic mode.

The indicator will come on.

---

### n Mirror angle can be adjusted when

The "ENGINE START STOP" switch is in ACCESSORY or IGNITION ON mode.

### n Linked mirror function when reversing

The outside rear view mirrors will automatically angle downwards when the vehicle is reversing in order to give a better view of the ground. This function only operates when either the "L" or "R" mirror select button is selected.

### n When the mirrors are fogged up

Turn on the mirror defoggers to defog the mirrors. (→P. 281)

**n Automatic adjustment of the mirror angle (vehicles with driving position memory)**

A desired mirror face angle can be entered to memory and recalled automatically by the driving position memory. (→P. 70)

**n Auto anti-glare function (if equipped)**

When the anti-glare inside rear view mirror is set to automatic mode, the outside rear view mirrors will activate in conjunction with the anti-glare inside rear view mirror to reduce reflected light. (→P. 85)

**! CAUTION**

**n When driving the vehicle**

Observe the following precautions while driving.

Failing to do so may result in loss of control of the vehicle and cause an accident, resulting in death or serious injury.

**I** Do not adjust the mirrors while driving.

**I** Do not drive with the mirrors folded.

**I** Both the driver and passenger side mirrors must be extended and properly adjusted before driving.

**n When a mirror is moving**

To avoid personal injury and mirror malfunction, be careful not to get your hand caught by the moving mirror.

**n When the mirror defoggers are operating**

Do not touch the rear view mirror surfaces, as they can become very hot and burn you.

## 1-4. Opening and closing the windows and moon roof

### Power windows

The power windows can be opened and closed using the switches.

Operating the switch moves the windows as follows:



- 1 Closing
- 2 One-touch closing\*
- 3 Opening
- 4 One-touch opening\*

\*: Pushing the switch in the opposite direction will stop window travel partway.



### Window lock switch



Press the switch to lock the passenger window switches.

The indicator will come on.

Use this switch to prevent children from accidentally opening or closing a passenger window.

The passenger windows can still be opened and closed using the power window switches on the driver's side even if the lock switch is on.

### n The power windows can be operated when

The “ENGINE START STOP” switch is in IGNITION ON mode.

### n Operating the power windows after turning the engine off

The power windows can be operated for approximately 45 seconds even after the “ENGINE START STOP” switch is turned to ACCESSORY mode or turned off. They cannot, however, be operated once either front door is opened.

### n Jam protection function

If an object becomes caught between the window and the window frame, window travel is stopped and the window is opened slightly.

### n When the power window does not close normally

If the jam protection function is operating abnormally and a window cannot be closed, perform the following operations using the power window switch on the relevant door.

1 After stopping the vehicle, the window can be closed by holding the power window switch in the one-touch closing position while the “ENGINE START STOP” switch is turned to IGNITION ON mode.

1 If the window still cannot be closed even by carrying out the operation explained above, initialize the function by performing the following procedure.

**STEP 1** Hold the power window switch in the one-touch closing position. Continue holding the switch for a further 6 seconds after the window has closed.

**STEP 2** Hold the power window switch in the one-touch opening position. Continue holding the switch for a further 2 seconds after the window has opened completely.

**STEP 3** Hold the power window switch in the one-touch closing position once again. Continue holding the switch for a further 2 seconds after the window has closed.

If you release the switch while the window is moving, start again from the beginning. If the window continues to close but then re-open slightly even after performing the above procedure correctly, have the vehicle inspected by your Lexus dealer.

### n Door lock linked window operation

- 1 The power windows can be opened and closed using the mechanical key. (→P. 581)
- 1 The power windows can be opened using the wireless remote control. (→P. 43)

### n When the battery is disconnected

The window lock switch is disabled. If necessary, press the window lock switch after reconnecting the battery.

### n Customization

Settings (e.g. linked door lock operation) can be changed. (Customizable features →P. 621)

## CAUTION

### n Closing the windows

Observe the following precautions.

Failing to do so may result in death or serious injury.

- 1 Check to make sure that all passengers do not have any part of their body in a position where it could be caught when a window is being operated.
- 1 Do not allow children to operate the power windows. Closing a power window on someone can cause serious injury, and in some instances, even death.

### n Jam protection function

- 1 Never use any part of your body to intentionally activate the jam protection function.
- 1 The jam protection function may not work if something gets caught just before the window fully closes. Also, the jam protection does not operate when the power window switch is pulled up continually to close the windows.

## 1-4. Opening and closing the windows and moon roof

### Moon roof\*

Use the overhead switches to open and close the moon roof and tilt it up and down.

#### n Opening and closing

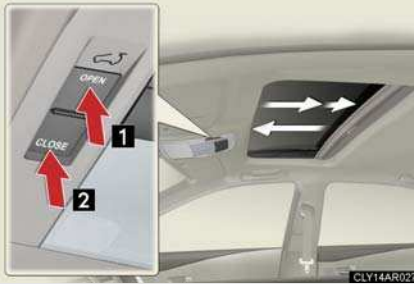

#### 1 Opens the moon roof\*

The moon roof stops slightly before the fully open position to reduce wind noise.

Press the switch again to fully open the moon roof.

#### 2 Closes the moon roof\*

\*: Lightly press either of the moon roof switches to stop the moon roof partway.

#### n Tilting up and down

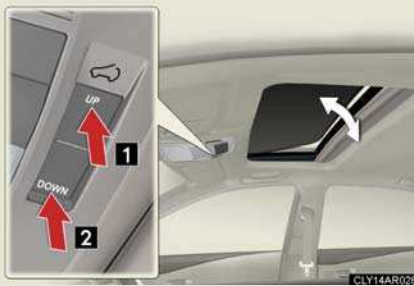

#### 1 Tilts the moon roof up\*

#### 2 Tilts the moon roof down\*

\*: Lightly press either of the moon roof switches to stop the moon roof partway.

### ■ **The moon roof can be operated when**

The "ENGINE START STOP" switch is in IGNITION ON mode.

### ■ **Operating the moon roof after turning the engine off**

The moon roof can be operated for approximately 45 seconds even after the "ENGINE START STOP" switch is turned to ACCESSORY mode or turned off. It cannot, however, be operated once either front door is opened.

### ■ **Jam protection function**

If an object is detected between the moon roof and the frame while closing or tilting down, travel is stopped and the moon roof opens slightly.

### ■ **Sunshade**

The sunshade can be opened and closed manually. However, the sunshade will open automatically when the moon roof is opened.

### ■ **Door lock linked moon roof operation**

1 The moon roof can be opened and closed using the mechanical key. (→P. 581)

1 The moon roof can be opened using the wireless remote control. (→P. 43)

## n When the moon roof does not close normally

Perform the following procedure:

1 If the moon roof closes but then re-opens slightly

**STEP 1** Stop the vehicle.

**STEP 2** Press and hold the “CLOSE” switch.\*1

The moon roof will close, reopen and pause for approximately 10 seconds.\*2 Then it will close again, tilt up and pause for approximately 1 second. Finally, it will tilt down, open and close.

**STEP 3** Check to make sure that the moon roof is completely closed and then release the switch.

1 If the moon roof tilts down but then tilts back up

**STEP 1** Stop the vehicle.

**STEP 2** Press and hold the “UP” switch\*1 until the moon roof moves into the tilt up position and stops.

**STEP 3** Release the “UP” switch once and then press and hold the “UP” switch again.\*1

The moon roof will pause for approximately 10 seconds in the tilt up position.\*2 Then it will adjust slightly and pause for approximately 1 second. Finally, it will tilt down, open and close.

**STEP 4** Check to make sure that the moon roof is completely closed and then release the switch.

\*1: If the switch is released at the incorrect time, the procedure will have to be performed again from the beginning.

\*2: If the switch is released after the above mentioned 10 second pause, automatic operation will be disabled. In that case, press and hold the “CLOSE” or “UP” switch, and the moon roof will tilt up and pause for approximately 1 second. Then it will tilt down, open and close. Check to make sure that the moon roof is completely closed and then release the switch.

If the moon roof does not fully close even after performing the above procedure correctly, have the vehicle inspected by your Lexus dealer.

## n Customization

Settings (e.g. linked door lock operation) can be changed.  
(Customizable features →P. 621)



### CAUTION

#### **n Opening the moon roof**

Observe the following precautions.

Failing to do so may cause death or serious injury.

**1** Do not allow any passengers to put their hands or heads outside the vehicle while it is moving.

**1** Do not sit on top of the moon roof.

#### **n Closing the moon roof**

Observe the following precautions.

Failing to do so may result in death or serious injury.

**1** Check to make sure that all passengers do not have any part of their body in a position where it could be caught when the moon roof is being operated.

**1** Do not allow children to operate the moon roof.

Closing the moon roof on someone can cause death or serious injury.

#### **n Jam protection function**

Observe the following precautions.

Failing to do so may result in death or serious injury.

**1** Never use any part of your body to intentionally activate the jam protection function.

**1** The jam protection function may not work if something gets caught just before the moon roof fully closes. Be careful not to catch fingers or anything else.

## 1-5. Refueling

# Opening the fuel tank cap

Perform the following steps to open the fuel tank cap:

**n Before refueling the vehicle**

Turn the “ENGINE START STOP” switch off and ensure that all the doors and windows are closed.

**n Opening the fuel tank cap**



Press the opener to open the fuel filler door.

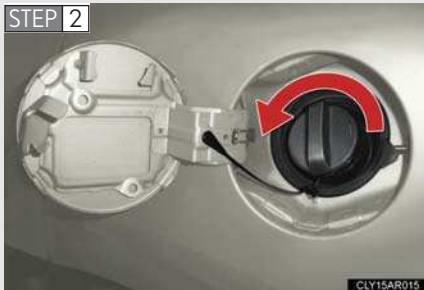

Turn the fuel tank cap slowly to open.

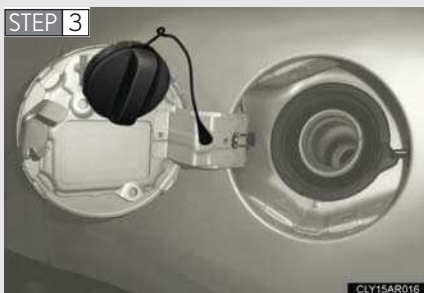

Hang the fuel tank cap on the back of the fuel filler door.

## Closing the fuel tank cap



After refueling, turn the fuel tank cap until you hear a click. Once the cap is released, it will turn slightly in the opposite direction.

### n If the fuel filler door opener is inoperable

**STEP 1** Pull the lever upwards to lift the deck board up. (→P. 421)

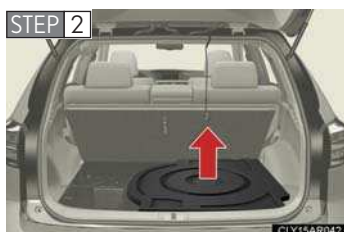

With a compact spare tire only:  
Remove the spare tire cover.

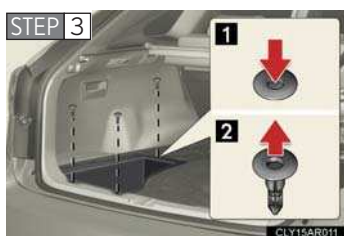

Remove the auxiliary box.



Pull the lever.

The lever can be used to open the fuel filler door if the fuel filler door cannot be opened using the inside switch.

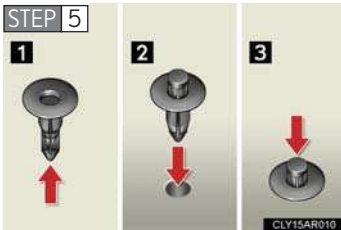

Install the clips.

### CAUTION

#### **n** When refueling the vehicle

Observe the following precautions while refueling the vehicle. Failure to do so may result in death or serious injury.

- 1 After exiting the vehicle and before opening the fuel door, touch an unpainted metal surface to discharge any static electricity. It is important to discharge static electricity before refueling because sparks resulting from static electricity can cause fuel vapors to ignite while refueling.
- 1 Always hold the grips on the fuel tank cap and turn it slowly to remove it. A whooshing sound may be heard when the fuel tank cap is loosened. Wait until the sound cannot be heard before fully removing the cap. In hot weather, pressurized fuel may spray out of the filler neck and cause injury.

### CAUTION

- I Do not allow anyone that has not discharged static electricity from their body to come close to an open fuel tank.
- I Do not inhale vaporized fuel.  
Fuel contains substances that are harmful if inhaled.
- I Do not smoke while refueling the vehicle.  
Doing so may cause the fuel to ignite and cause a fire.
- I Do not return to the vehicle or touch any person or object that is statically charged.  
This may cause static electricity to build up, resulting in a possible ignition hazard.

#### **n When refueling**

Securely insert the fuel nozzle into the fuel filler neck. If fuel is added with the nozzle slightly lifted away from the fuel filler neck, the automatic shut off function may not operate, resulting in fuel overflowing from the tank.

#### **n When replacing the fuel cap**

Do not use anything but a genuine Lexus fuel tank cap designed for your vehicle. Doing so may cause a fire or other incident which may result in death or serious injury.

### NOTICE

#### **n Refueling**

Do not spill fuel during refueling.  
Doing so may damage the vehicle, such as causing the emission control system to operate abnormally or damaging fuel system components or the vehicle's painted surface.

## 1-6. Theft deterrent system

### Engine immobilizer system

The vehicle's keys have built-in transponder chips that prevent the engine from starting if the key has not been previously registered in the vehicle's on-board computer.

Never leave the keys inside the vehicle when you leave the vehicle.



The indicator light flashes after the “ENGINE START STOP” switch has been turned off to indicate that the system is operating.

The indicator light stops flashing after the “ENGINE START STOP” switch has been turned to ACCESSORY or IGNITION ON mode to indicate that the system has been canceled.

#### n System maintenance

The vehicle has a maintenance-free type engine immobilizer system.

#### n Conditions that may cause the system to malfunction

- l If the grip portion of the key is in contact with a metallic object
- l If the key is in close proximity to or touching a key to the security system (key with a built-in transponder chip) of another vehicle

### **n Certifications for the engine immobilizer system**

- ▶ For vehicles sold in the U.S.A.

FCC ID: NI4TMIMB-1

This device complies with Part 15 of the FCC Rules. Operation is subject to the following two conditions: (1) this device may not cause harmful interference, and (2) this device must accept any interference received, including interference that may cause undesired operation.

- ▶ For vehicles sold in Canada

Operation is subject to the following two conditions: (1) this device may not cause interference, and (2) this device must accept any interference, including interference that may cause undesired operation of the device.

L'utilisation de ce dispositif est autorisée seulement aux deux conditions suivantes: (1) il ne doit pas produire de brouillage, et (2) l'utilisateur du dispositif doit être prêt à accepter tout brouillage radioélectrique reçu, même si ce brouillage est susceptible de compromettre le fonctionnement du dispositif.

### **⚠ CAUTION**

#### **n Certifications for the immobilizer system**

Changes or modifications not expressly approved by the party responsible for compliance could void the user's authority to operate the equipment.

### **⚠ NOTICE**

#### **n To ensure the system operates correctly**

Do not modify or remove the system. If modified or removed, the proper operation of the system cannot be guaranteed.

# Alarm

The system sounds the alarm and flashes the lights when forcible entry is detected.

### n Triggering of the alarm

The alarm is triggered in the following situations when the alarm is set:

- 1 A locked door is unlocked or opened in any way other than using the entry function, wireless remote control or mechanical key.
- 1 The hood is opened.
- 1 Some models: The back door window is tapped or broken.

### n Setting the alarm system



Close the doors and hood, and lock all the doors.

The system will be set automatically after 30 seconds.

The indicator light changes from being on to flashing when the system is set.

### n Deactivating or stopping the alarm

Do one of the following to deactivate or stop the alarms:

- 1 Unlock the doors.
- 1 Turn the “ENGINE START STOP” switch to ACCESSORY or IGNITION ON mode, or start the engine. (The alarm will be deactivated or stopped after a few seconds.)



### ■ System maintenance

The vehicle has a maintenance-free type alarm system.

### ■ Items to check before locking the vehicle

To prevent unexpected triggering of the alarm and vehicle theft, make sure of the following:

- 1 Nobody is in the vehicle.
- 1 The windows and moon roof are closed before the alarm is set.
- 1 No valuables or other personal items are left in the vehicle.

### ■ Triggering of the alarm

The alarm may be triggered in the following situations:  
(Stopping the alarm deactivates the alarm system.)



- 1 A person inside the vehicle opens a door or the hood.

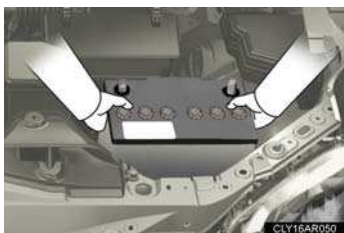

- 1 The battery is recharged or replaced when the vehicle is locked.

### ■ Alarm-operated door lock

- 1 When the alarm is operating, the doors are locked automatically to prevent intruders.
- 1 Do not leave the key inside the vehicle when the alarm is operating, and make sure the key is not inside the vehicle when recharging or replacing the battery.

 NOTICE**n To ensure the system operates correctly**

Do not modify or remove the system. If modified or removed, the proper operation of the system cannot be guaranteed.

1

Before driving

## 1-6. Theft deterrent system

### Theft prevention labels (for U.S.A.)



C1Y16AR003

These labels are attached to the vehicle to reduce vehicle theft by facilitating the tracing and recovery of parts from stolen vehicles. Do not remove under penalty of law.

## Correct driving posture

Drive in a good posture as follows:



- 1 Sit upright and well back in the seat. (→P. 61)
- 2 Adjust the position of the seat forward or backward to ensure the pedals can be reached and easily depressed to the extent required. (→P. 61)
- 3 Adjust the seatback so that the controls are easily operable. (→P. 61)
- 4 Adjust the tilt and telescopic positions of the steering wheel downward so the air-bag is facing your chest. (→P. 83)
- 5 Lock the head restraint in place with the center of the head restraint closest to the top of your ears. (→P. 73)
- 6 Wear the seat belt correctly. (→P. 75)

### CAUTION

#### **n While driving**

- 1** Do not adjust the position of the driver's seat.  
Doing so could cause the driver to lose control of the vehicle.
- 1** Do not place a cushion between the driver or passenger and the seatback.  
A cushion may prevent correct posture from being achieved, and reduce the effectiveness of the seat belt and head restraint, increasing the risk of death or serious injury to the driver or passenger.
- 1** Do not place anything under the front seats.  
Objects placed under the front seats may become jammed in the seat tracks and stop the seat from locking in place. This may lead to an accident, resulting in death or serious injury. The adjustment mechanism may also be damaged.

#### **n Adjusting the seat position**

- 1** Take care when adjusting the seat position to ensure that other passengers are not injured by the moving seat.
- 1** Do not put your hands under the seat or near the moving parts to avoid injury.  
Fingers or hands may become jammed in the seat mechanism.

## SRS airbags

The SRS airbags inflate when the vehicle is subjected to certain types of severe impacts that may cause significant injury to the occupants. They work together with the seat belts to help reduce the risk of death or serious injury.

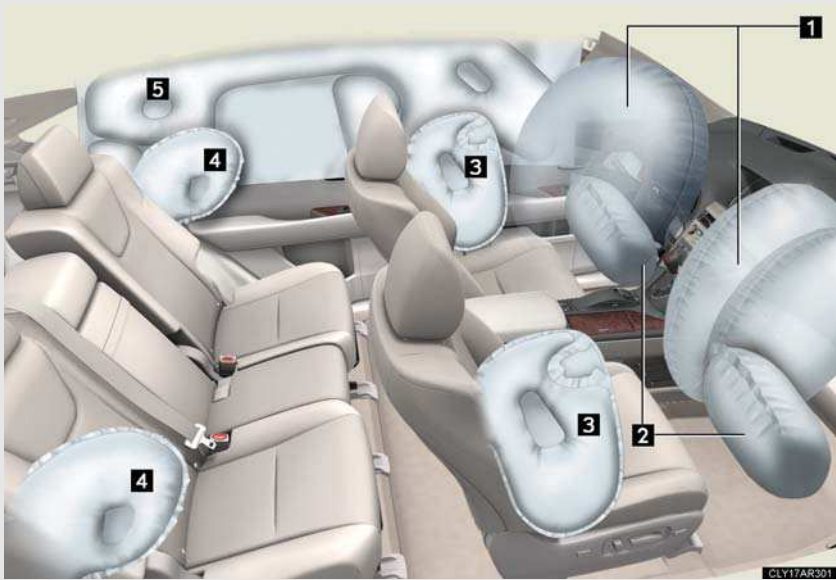

► SRS front airbags

**1** SRS driver airbag/front passenger airbag

Can help protect the head and chest of the driver and front passenger from impact with interior components

**2** SRS knee airbags

Can help provide driver and front passenger protection

- ▶ SRS side and curtain shield airbags
- 3 Front SRS side airbags
  - Can help protect the torso of the front seat occupants
- 4 Rear SRS side airbags
  - Can help protect the torso of occupants in the rear outer seats
- 5 SRS curtain shield airbags
  - Can help protect primarily the head of occupants in the outer seats

## SRS airbag system components

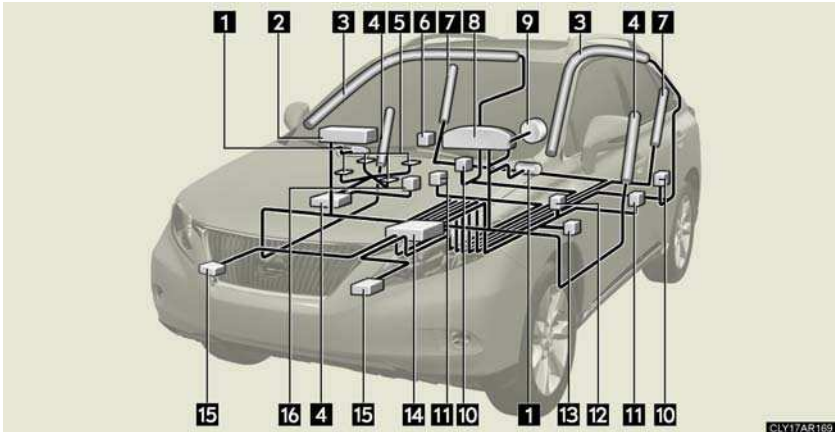

- |  |   |
|--|---|
| <b>1</b> Knee airbags                                    | <b>10</b> Curtain shield airbag sensors             |
| <b>2</b> Front passenger airbag                          | <b>11</b> Side and curtain shield airbag sensors    |
| <b>3</b> Curtain shield airbags                          | <b>12</b> Driver's seat belt buckle switch          |
| <b>4</b> Front side airbags                              | <b>13</b> Driver's seat position sensor             |
| <b>5</b> Occupant detection system (ECU and sensors)     | <b>14</b> Airbag sensor assembly                    |
| <b>6</b> "AIR BAG ON" and "AIR BAG OFF" indicator lights | <b>15</b> Front airbag sensors                      |
| <b>7</b> Rear side airbags                               | <b>16</b> Front passenger's seat belt buckle switch |
| <b>8</b> SRS warning light                               |   |
| <b>9</b> Driver airbag                                   |   |

Your vehicle is equipped with ADVANCED AIRBAGS designed based on US motor vehicle safety standards (FMVSS208). The airbag system controls airbag deployment power for the driver and front passenger. The driver airbag system consists of the driver's seat position sensor etc. The front passenger's airbag system consists of the front passenger occupant classification sensor etc.



The main SRS airbag system components are shown above. The SRS airbag system is controlled by the airbag sensor assembly. The airbag sensor assembly consists of a safing sensor and an airbag sensor.

In certain types of severe frontal or side impacts, the SRS airbag system triggers the airbag inflators. A chemical reaction in the inflators quickly fills the airbags with non-toxic gas to help restrain the motion of the occupants.

---

### n If the SRS airbags deploy (inflate)

- 1 Bruising and slight abrasions may result from contact with a deploying (inflating) SRS airbag.
- 1 A loud noise and white powder will be emitted.
- 1 Parts of the airbag module (steering wheel hub, airbag cover and inflator) as well as the seats, and parts of the front and rear pillars, and roof side rails, may be hot for several minutes. The airbag itself may also be hot.
- 1 The windshield may crack.
- 1 For Safety Connect subscribers, if the SRS airbags deploy or in the event of a severe rear-end collision, the system is designed to send an emergency call to the response center, notifying them of the vehicle's location (without needing to push the "SOS" button) and an agent will attempt to speak with the occupants to ascertain the level of emergency and assistance required. If the occupants are unable to communicate, the agent automatically treats the call as an emergency and helps to dispatch the necessary emergency services. (→P. 436)

### n SRS airbag deployment conditions (SRS front airbags)

- l The SRS front airbags will deploy in the event of an impact that exceeds the set threshold level (the level of force corresponding to an approximately 12 - 18 mph [20 - 30 km/h] frontal collision with a fixed wall that does not move or deform).

However, this threshold velocity will be considerably higher if the vehicle strikes an object, such as a parked vehicle or sign pole, which can move or deform on impact, or if the vehicle is involved in an underride collision (e.g. a collision in which the front of the vehicle “underrides”, or goes under, the bed of a truck, etc.).

- l It is possible that in some collisions where the forward deceleration of the vehicle is very close to the designed threshold level, the SRS front airbags and the seat belt pretensioners may not activate together.
- l The SRS front passenger airbag will not activate if there is no passenger sitting in the front passenger seat. However, the SRS front passenger airbag may deploy if luggage is put in the seat, or the seat belt is fastened, even if the seat is unoccupied. (→P. 75)

### n SRS airbag deployment conditions (SRS side airbags and curtain shield airbags)

The SRS side airbags and curtain shield airbags will deploy in the event of an impact that exceeds the set threshold level (the level of force corresponding to the impact force produced by an approximately 3300 lb. [1500 kg] vehicle colliding with the vehicle cabin from a direction perpendicular to the vehicle orientation at an approximate speed of 12 - 18 mph [20 - 30 km/h]).

### ▢ Conditions under which the SRS airbags may deploy (inflate), other than a collision (SRS front airbags)

The SRS front airbags may also deploy if a serious impact occurs to the underside of your vehicle. Some examples are shown in the illustration.

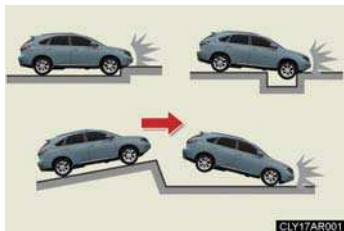

- 1 Hitting a curb, edge of pavement or hard surface
- 1 Falling into or jumping over a deep hole
- 1 Landing hard or vehicle falling

The SRS curtain shield airbags may also deploy under the situations shown in the illustration.



- 1 The angle of vehicle tip-up is marginal.
- 1 The vehicle skids and hits a curb stone.

### ▢ Types of collisions that may not deploy the SRS airbags (SRS front airbags)

The SRS front airbags are generally not designed to inflate if the vehicle is involved in a side or rear collision, if it rolls over, or if it is involved in a low-speed frontal collision. But, whenever a collision of any type causes sufficient forward deceleration of the vehicle, deployment of the SRS front airbags may occur.



- 1 Collision from the side
- 1 Collision from the rear
- 1 Vehicle rollover

## n Types of collisions that may not deploy the SRS airbags (SRS side airbags and curtain shield airbags)

The SRS side airbag and curtain shield airbag system may not activate if the vehicle is subjected to a collision from the side at certain angles, or a collision to the side of the vehicle body other than the passenger compartment.

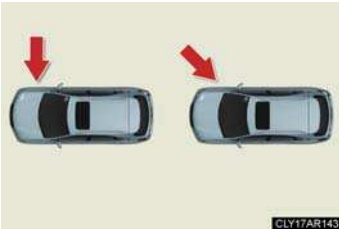

- 1 Collision from the side to the vehicle body other than the passenger compartment
- 1 Collision from the side at an angle

The SRS side airbags and curtain shield airbags are not generally designed to inflate if the vehicle is involved in a frontal or rear collision, if it rolls over, or if it is involved in a low-speed side collision.



- 1 Collision from the front
- 1 Collision from the rear
- 1 Vehicle rollover

### ■ When to contact your Lexus dealer

In the following cases, contact your Lexus dealer as soon as possible.

#### 1 Any of the SRS airbags has been inflated.

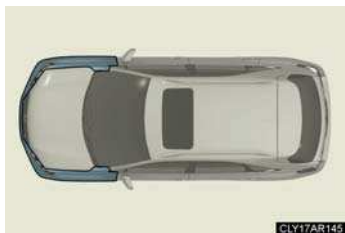

- 1 The front of the vehicle is damaged or deformed, or was involved in an accident that was not severe enough to cause the SRS airbags to inflate.

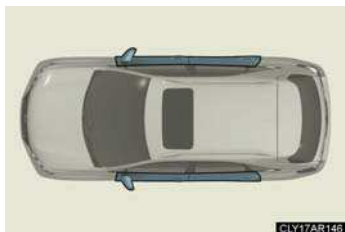

- 1 A portion of the doors is damaged or deformed, or the vehicle was involved in an accident that was not severe enough to cause the SRS side airbags and curtain shield airbags to inflate.



- 1 The pad section of the steering wheel, dashboard near the front passenger airbag or lower portion of the instrument panel is scratched, cracked, or otherwise damaged.



- 1 The surface of the seats with the side airbag is scratched, cracked, or otherwise damaged.
- 1 The portion of the front pillars, rear pillars or roof side rail garnishes (padding) containing the curtain shield airbags inside is scratched, cracked, or otherwise damaged.

**! CAUTION****n SRS airbag precautions**

Observe the following precautions regarding the SRS airbags. Failure to do so may cause death or serious injury.

- 1** The driver and all passengers in the vehicle must wear their seat belts properly. The SRS airbags are supplemental devices to be used with the seat belts.
- 1** The SRS driver airbag deploys with considerable force, and can cause death or serious injury especially if the driver is very close to the airbag. The National Highway Traffic Safety Administration ("NHTSA") advises:

Since the risk zone for driver's airbag is the first 2 - 3 in. (50 - 75 mm) of inflation, placing yourself 10 in. (250 mm) from your driver airbag provides you with a clear margin of safety. This distance is measured from the center of the steering wheel to your breastbone. If you sit less than 10 in. (250 mm) away now, you can change your driving position in several ways:

- Move your seat to the rear as far as you can while still reaching the pedals comfortably.
- Slightly recline the back of the seat. Although vehicle designs vary, many drivers can achieve the 10 in. (250 mm) distance, even with the driver seat all the way forward, simply by reclining the back of the seat somewhat. If reclining the back of your seat makes it hard to see the road, raise yourself by using a firm, non-slippery cushion, or raise the seat if your vehicle has that feature.
- If your steering wheel is adjustable, tilt it downward. This points the airbag toward your chest instead of your head and neck.

The seat should be adjusted as recommended by NHTSA above, while still maintaining control of the foot pedals, steering wheel, and your view of the instrument panel controls.

**! CAUTION**

**n SRS airbag precautions**



**I** If the seat belt extender has been connected to the driver's seat belt buckle but the seat belt extender has not also been fastened to the latch plate of the driver's seat belt, the SRS driver's airbag system will judge that the driver is wearing the seat belt even though the seat belt has not been connected. In this case, the driver's airbag may not activate correctly in a collision, resulting in death or serious injury in the event of collision. Be sure to wear the seat belt with the seat belt extender.

**I** The SRS front passenger airbag also deploys with considerable force, and can cause death or serious injury especially if the front passenger is very close to the airbag. The front passenger seat should be as far from the airbag as possible with the seatback adjusted, so the front passenger sits upright.

**I** Improperly seated and/or restrained infants and children can be killed or seriously injured by a deploying airbag. An infant or child who is too small to use a seat belt should be properly secured using a child restraint system. Lexus strongly recommends that all infants and children be placed in the rear seats of the vehicle and properly restrained. The rear seats are safer for infants and children than the front passenger seat. (→P. 127)

## ⚠ CAUTION

### n SRS airbag precautions



- 1 Do not sit on the edge of the seat or lean against the dashboard.



- 1 Do not allow a child to stand in front of the SRS front passenger airbag unit or sit on the knees of a front passenger.
- 1 Do not allow the front seat occupants to hold items on their knees.



- 1 Do not lean against the door, the roof side rail or the front, side and rear pillars.



- 1 Do not allow anyone to kneel on the passenger seats toward the door or put their head or hands outside the vehicle.

1

Before driving



**! CAUTION**

**n SRS airbag precautions**



**I** Do not attach anything to or lean anything against areas such as the dashboard, steering wheel pad or lower portion of the instrument panel.

These items can become projectiles when SRS driver, front passenger and knee airbags deploy.



**I** Do not attach anything to areas such as the door, windshield glass, side door glass, front and rear pillars, roof side rail or assist grip.

**I** Do not hang coat hangers or other hard objects on the coat hooks. All of these items could become projectiles and may cause death or serious injury, should the SRS curtain shield airbags deploy.

- I** If a vinyl cover is put on the area where the SRS knee airbags will deploy, be sure to remove it.
- I** Do not use seat accessories which cover the parts where the SRS side airbags inflate as they may interfere with inflation of the airbags. Such accessories may prevent the side airbags from activating correctly, disable the system or cause the side airbags to inflate accidentally, resulting in death or serious injury.
- I** Do not strike or apply significant levels of force to the area of the SRS airbag components.  
Doing so can cause the SRS airbags to malfunction.
- I** Do not touch any of the component parts immediately after the SRS airbags have deployed (inflated) as they may be hot.
- I** If breathing becomes difficult after the SRS airbags have deployed, open a door or window to allow fresh air in, or leave the vehicle if it is safe to do so. Wash off any residue as soon as possible to prevent skin irritation.
- I** If the areas where the SRS airbags are stored, such as the steering wheel pad and front and rear pillar garnishes, are damaged or cracked, have them replaced by your Lexus dealer.

 **CAUTION****n SRS airbag precautions**

- 1 Do not place anything, such as a cushion, on the front passenger's seat. Doing so will disperse the passenger's weight, which prevents the sensor from detecting the passenger's weight properly. As a result, the SRS front passenger airbag may not deploy in the event of a collision.

**n Modification and disposal of SRS airbag system components**

Do not dispose of your vehicle or perform any of the following modifications without consulting your Lexus dealer.

The SRS airbags may malfunction or deploy (inflate) accidentally, causing death or serious injury.

- 1 Installation, removal, disassembly and repair of the SRS airbags
- 1 Repairs, modifications, removal or replacement of the steering wheel, instrument panel, dashboard, seats or seat upholstery, front, side and rear pillars or roof side rails
- 1 Repairs or modifications of the front fender, front bumper, or side of the occupant compartment
- 1 Installation of snow plows, winches, etc. to the front grille (bull bars or kangaroo bar etc.)
- 1 Modifications to the vehicle's suspension system
- 1 Installation of electronic devices such as mobile two-way radios or CD players
- 1 Modifications to your vehicle for a person with a physical disability

## 1-7. Safety information

### Front passenger occupant classification system

Your vehicle is equipped with a front passenger occupant classification system. This system detects the conditions of the front passenger seat and activates or deactivates the devices for the front passenger.



- 1 SRS warning light
- 2 "AIR BAG OFF" indicator light
- 3 "AIR BAG ON" indicator light
- 4 Front passenger's seat belt reminder light

## Condition and operation in the front passenger occupant classification system

### n Adult<sup>\*1</sup>

Indicator/ warning light	"AIR BAG ON" and "AIR BAG OFF" indicator lights	"AIR BAG ON"
	SRS warning light	Off
	Front passenger's seat belt reminder light	Flashing <sup>*2</sup>
Devices	Front passenger airbag	Activated
	Side airbag on the front passenger seats	
	Curtain shield airbag in the front passenger side	
	Front passenger knee airbag	
	Front passenger's seat belt pretensioner	

1

Before driving

### n Child<sup>\*3</sup> or child restraint system<sup>\*4</sup>

Indicator/ warning light	"AIR BAG ON" and "AIR BAG OFF" indicator lights	"AIR BAG OFF" <sup>*5</sup>
	SRS warning light	Off
	Front passenger's seat belt reminder light	Flashing <sup>*2</sup>
Devices	Front passenger airbag	Deactivated
	Side airbag on the front passenger seats	Activated
	Curtain shield airbag in the front passenger side	
	Front passenger knee airbag	Deactivated
	Front passenger's seat belt pretensioner	Activated

**n Unoccupied**

Indicator/ warning light	“AIR BAG ON” and “AIR BAG OFF” indicator lights	Not illuminated
	SRS warning light	Off
	Front passenger’s seat belt reminder light	
Devices	Front passenger airbag	Deactivated
	Side airbag on the front passenger seats	Activated
	Curtain shield airbag in the front passenger side	
	Front passenger knee airbag	Deactivated
	Front passenger’s seat belt pretensioner	

**n There is a malfunction in the system**

Indicator/ warning light	“AIR BAG ON” and “AIR BAG OFF” indicator lights	“AIR BAG OFF”
	SRS warning light	On
	Front passenger’s seat belt reminder light	Off
Devices	Front passenger airbag	Deactivated
	Side airbag on the front passenger seats	Activated
	Curtain shield airbag in the front passenger side	
	Front passenger knee airbag	Deactivated
	Front passenger’s seat belt pretensioner	Activated

- \*1: The system judges a person of adult size as an adult. When a smaller adult sits in the front passenger seat, the system may recognize him/her as a child depending on his/her physique and posture.
- \*2: In the event the front passenger does not wear a seat belt.
- \*3: When a larger child who has outgrown a child restraint system sits in the front passenger seat, the system may recognize him/her as an adult depending on his/her physique or posture.

- \*4: Never install a rear-facing child restraint system on the front passenger seat. A forward-facing child restraint system should only be installed on the front passenger seat when it is unavoidable. (→P. 127)
- \*5: In case indicator light is not illuminated, consult this manual on how to install the child restraint system properly. (→P. 131)

### CAUTION

#### **n Front passenger occupant classification system precautions**

Observe the following precautions regarding the front passenger occupant classification system.

Failure to do so may cause death or serious injury.

- I** Wear the seat belt properly.
- I** Make sure the front passenger's seat belt tab has not been left inserted into the buckle before someone sits in the front passenger seat.
- I** Make sure the "AIR BAG OFF" indicator light is not illuminated when using the seat belt extender for the front passenger seat. If the "AIR BAG OFF" indicator light is illuminated, disconnect the extender tongue from the seat belt buckle, then reconnect the seat belt. Reconnect the seat belt extender after making sure the "AIR BAG ON" indicator light is illuminated. If you use the seat belt extender while the "AIR BAG OFF" indicator light is illuminated, the front passenger airbag, side airbag on the front passenger side and front passenger knee airbag may not activate correctly, which could cause death or serious injury in the event of collision.
- I** Do not apply a heavy load to the front passenger seat or equipment.
- I** Do not put weight on the front passenger seat by putting your hands or feet on the front passenger seat seatback from the rear passenger seat.
- I** Do not let a rear passenger lift the front passenger seat with their feet or press on the seatback with their legs.
- I** Do not put objects under the front passenger seat.

 **CAUTION**

**n Front passenger occupant classification system precautions**

- 1 Do not recline the front passenger seatback so far that it touches a rear seat. This may cause the “AIR BAG OFF” indicator light to be illuminated, which indicates that the passenger’s airbags will not deploy in the event of a severe accident. If the seatback touches the rear seat, return the seatback to a position where it does not touch the rear seat. Keep the front passenger seatback as upright as possible when the vehicle is moving. Reclining the seatback excessively may lessen the effectiveness of the seat belt system.
- 1 If an adult sits in the front passenger seat, the “AIR BAG ON” indicator light is illuminated. If the “AIR BAG OFF” indicator is illuminated, ask the passenger to sit up straight, well back in the seat, feet on the floor, and with the seat belt worn correctly. If the “AIR BAG OFF” indicator still remains illuminated, either ask the passenger to move to the rear seat, or if that is not possible, move the front passenger seat fully rearward.
- 1 When it is unavoidable to install the forward-facing child restraint system on the front passenger seat, install the child restraint system on the front passenger seat in the proper order. (→P. 131)
- 1 Do not modify or remove the front seats.
- 1 Do not kick the front passenger seat or subject it to severe impact. Otherwise, the SRS warning light may come on to indicate a malfunction of the detection system. In this case, contact your Lexus dealer immediately.
- 1 Child restraint systems installed on the rear seat should not contact the front seatbacks.
- 1 Do not use a seat accessory, such as a cushion or seat cover, that covers the seat cushion surface.
- 1 Do not modify or replace the upholstery of the front seat.

# Child restraint systems

A child restraint system for a small child or baby must itself be properly restrained on the seat with the lap portion of the lap/shoulder belt.

The laws of all 50 states of the U.S.A. and Canada now require the use of child restraint systems.

### Points to remember

Studies have shown that installing a child restraint on a rear seat is much safer than installing one to the front passenger seat.

- 1 Choose a child restraint system that suits your vehicle and is appropriate to the age and size of the child.
- 1 For installation details, follow the instructions provided with the child restraint system.  
General installation instructions are provided in this manual. (→P.131)

### Types of child restraints

Child restraint systems are classified into the following 3 types according to the age and size of the child.

- ▶ Rear facing — Infant seat/convertible seat





### ▶ Forward facing — Convertible seat



### ▶ Booster seat



---

#### ■ Selecting an appropriate child restraint system

- 1 Use a child restraint system appropriate for the child until the child becomes large enough to properly wear the vehicle's seat belt.
- 1 If the child is too large for a child restraint system, sit the child on a rear seat and use the vehicle's seat belt. (→P. 75)

 **CAUTION****n Child restraint precautions**

- I** For effective protection in automobile accidents and sudden stops, a child must be properly restrained, using a seat belt or child restraint system depending on the age and size of the child. Holding a child in your arms is not a substitute for a child restraint system. In an accident, the child can be crushed against the windshield, or between you and the vehicle's interior.
- I** Lexus strongly urges the use of a proper child restraint system that conforms to the size of the child, installed on the rear seat. According to accident statistics, the child is safer when properly restrained in the rear seat than in the front seat.
- I** Never install a rear-facing child restraint system on the front passenger seat even if the "AIR BAG OFF" indicator light is illuminated. In the event of an accident, the force of the rapid inflation of the front passenger airbag can cause death or serious injury to the child if a rear-facing child restraint system is installed on the front passenger seat.
- I** A forward-facing child restraint system may be allowed to be installed on the front passenger seat only when it is unavoidable. A child restraint system that requires a top tether strap should not be used in the front passenger seat since there is no top tether strap anchor for the front passenger seat. Adjust the seat-back as upright as possible and always move the seat as far back as possible even if the "AIR BAG OFF" indicator light is illuminated, because the front passenger airbag could inflate with considerable speed and force. Otherwise, the child may be killed or seriously injured.
- I** Do not use the seat belt extender when installing a child restraint system on the front or rear passenger seat. If installing a child restraint system with the seat belt extender connected to the seat belt, the seat belt will not securely hold the child restraint system, which could cause death or serious injury to the child or other passengers in the event of a sudden stop, sudden swerve or an accident.
- I** Do not allow the child to lean his/her head or any part of his/her body against the door or the area of the seat, front and rear pillars or roof side rails from which the SRS side airbags or SRS curtain shield airbags deploy even if the child is seated in the child restraint system. It is dangerous if the side airbags and curtain shield airbags inflate, and the impact could cause death or serious injury to the child.

### CAUTION

#### **n Child restraint precautions**

**I** Make sure you have complied with all installation instructions provided by the child restraint manufacturer and that the system is properly secured. If it is not secured properly, it may cause death or serious injury to the child in the event of a sudden stop, sudden swerve or an accident.

#### **n Child restraint lock function belt precaution**

Do not allow children to play with the child restraint lock function belt. If the belt becomes twisted around a child's neck, it will not be possible to pull the belt out leading to choking or other serious injuries that could result in death.

If this occurs and the buckle cannot be unfastened, scissors should be used to cut the belt.

#### **n When the child restraint system is not in use**

**I** Keep the child restraint system properly secured on the seat even if it is not in use. Do not store the child restraint system unsecured in the passenger compartment.

**I** If it is necessary to detach the child restraint system, remove it from the vehicle or store it securely in the luggage compartment. This will prevent it from injuring passengers in the event of a sudden stop, sudden swerve or accident.

## Installing child restraints

Follow the child restraint system manufacturer's instructions. Firmly secure child restraints to the seats using the LATCH anchors or a seat belt. Attach the top tether strap when installing a child restraint.

The lap/shoulder belt can be used if your child restraint system is not compatible with the LATCH (Lower Anchors and Tethers for Children) system.



Child restraint LATCH anchors  
LATCH anchors are provided for the outer rear seats. (Buttons displaying the location of the anchors are attached to the seats.)



Seat belts equipped with a child restraint locking mechanism (ALR/ELR belts except driver's seat belt) (→P. 75)

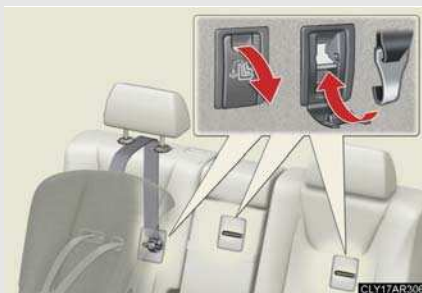

Anchor brackets (for top tether strap)

An anchor bracket is provided for each rear seat.

## Installation with LATCH system

STEP 1

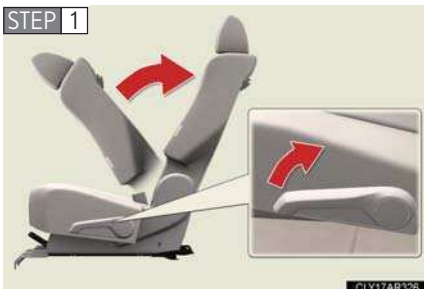

Fold the seatback while pulling the seatback angle adjustment lever. Return the seatback and secure it at the first lock position. (→P. 66)

STEP 2 Widen the gap between the seat cushion and seatback slightly.

► Type A

STEP 3

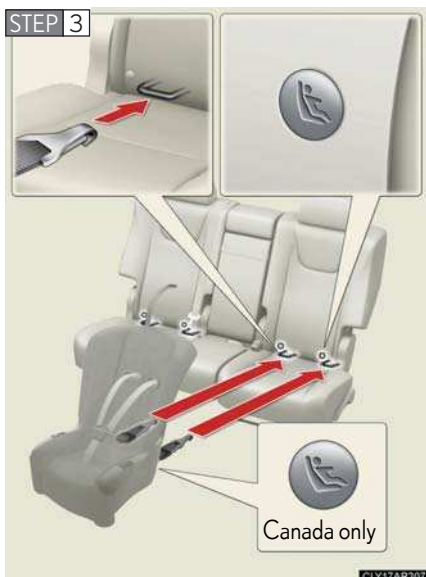

Latch the hooks of the lower straps onto the LATCH anchors. If the child restraint has a top tether strap, the top tether strap should be latched onto the top tether strap anchor bracket.

For owners in Canada:  
The symbol on a child restraint system indicates the presence of a lower connector system.

## ► Type B

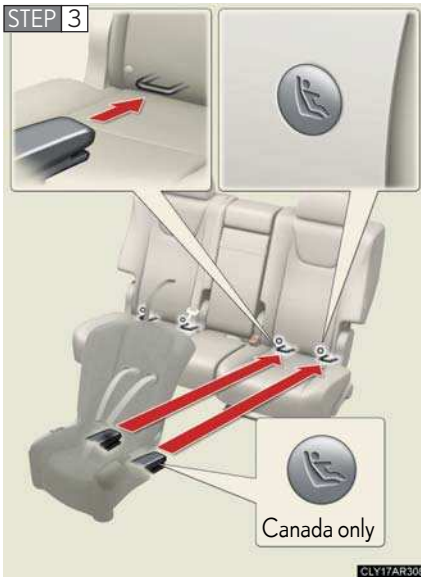

Latch the buckles onto the LATCH anchors. If the child restraint has a top tether strap, the top tether strap should be latched onto the top tether strap anchor bracket.

For owners in Canada:  
The symbol on a child restraint system indicates the presence of a lower connector system.

1

Before driving

## Installing child restraints using a seat belt (child restraint lock function belt)

### n Rear-facing — Infant seat/convertible seat

STEP 1

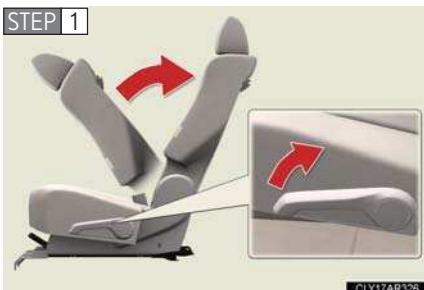

Fold the seatback while pulling the seatback angle adjustment lever. Return the seatback and secure it at the first lock position. (→P. 66)

STEP 2



Place the child restraint system on the rear seat facing the rear of the vehicle.

STEP 3



Run the seat belt through the child restraint system and insert the plate into the buckle. Make sure that the belt is not twisted.

STEP 4



Fully extend the shoulder belt and allow it to retract to put it in lock mode. In lock mode, the belt cannot be extended.

STEP 5



While pushing the child restraint system down into the rear seat, allow the shoulder belt to retract until the child restraint system is securely in place.

After the shoulder belt has retracted to a point where there is no slack in the belt, pull the belt to check that it cannot be extended.

### n Forward-facing — Convertible seat

STEP 1

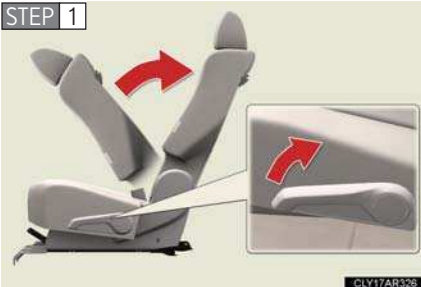

Fold the seatback while pulling the seatback angle adjustment lever. Return the seatback and secure it at the first lock position. (→P. 66)

STEP 2



Place the child restraint system on the seat facing the front of the vehicle.



STEP 3



Run the seat belt through the child restraint system and insert the plate into the buckle. Make sure that the belt is not twisted.

STEP 4



Fully extend the shoulder belt and allow it to retract to put it in lock mode. In lock mode, the belt cannot be extended.

STEP 5



While pushing the child restraint system into the rear seat, allow the shoulder belt to retract until the child restraint system is securely in place.

After the shoulder belt has retracted to a point where there is no slack in the belt, pull the belt to check that it cannot be extended.

**STEP 6** If the child restraint has a top tether strap, the top tether strap should be latched onto the top tether strap anchor. (→P.138)

## n Booster seat

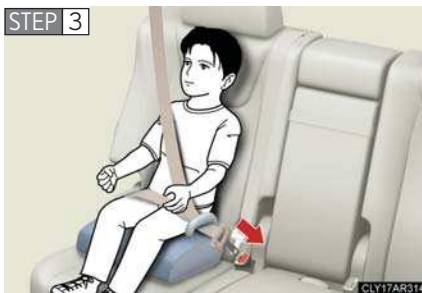
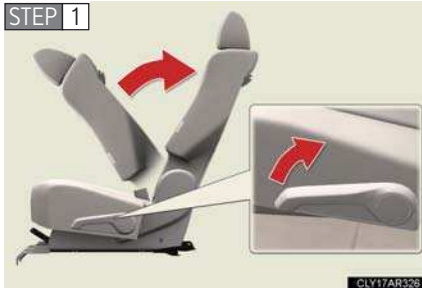

Fold the seatback while pulling the seatback angle adjustment lever. Return the seatback and secure it at the first lock position. (→P. 66)

Place the child restraint system on the seat facing the front of the vehicle.

Sit the child in the child restraint system. Fit the seat belt to the child restraint system according to the manufacturer's instructions and insert the plate into the buckle. Make sure that the belt is not twisted.

Check that the shoulder belt is correctly positioned over the child's shoulder, and that the lap belt is as low as possible. (→P. 75)

### Removing a child restraint installed with a seat belt



Press the buckle release button and fully retract the seat belt.

### Child restraint systems with a top tether strap



Secure the child restraint system using a seat belt or the LATCH anchors, and remove the head restraint.



Open the anchor bracket cover, latch the hook onto the anchor bracket and tighten the top tether strap.

Make sure the top tether strap is securely latched.

STEP 3



Replace the head restraint and lift it up to the uppermost lock position.

1

Before driving

#### n Laws and regulations pertaining to anchors

The LATCH system conforms to FMVSS225 or CMVSS210.2.

Child restraint systems conforming to FMVSS213 or CMVSS213 specifications can be used.

This vehicle is designed to conform to the SAE J1819.

#### ! CAUTION

##### n When installing a booster seat

To prevent the belt from going into ALR lock mode, do not fully extend the shoulder belt. ALR mode causes the belt to tighten only. This could cause injury or discomfort to the child. (→P. 78)

**! CAUTION**

**n When installing a child restraint system**

Follow the directions given in the child restraint system installation manual and fix the child restraint system securely in place.

If the child restraint system is not correctly fixed in place, the child or other passengers may be injured or even killed in the event of sudden braking, sudden swerving or an accident.



1 If the driver's seat interferes with the child restraint system and prevents it from being attached correctly, attach the child restraint system to the right-hand rear seat.

1 Adjust the front passenger seat so that it does not interfere with the child restraint system.



1 Only put a forward-facing child restraint system on the front seat when unavoidable. When installing a forward-facing child restraint system on the front passenger seat, move the seat as far back as possible even if the "AIR BAG OFF" indicator light is illuminated. Failure to do so may result in death or serious injury if the airbags deploy (inflate).

1 When installing a child restraint system in the rear center seat, adjust both seat cushions to the same position and align both seatbacks at the same angle. The seatbacks must be adjusted to the same angle. Otherwise, the child restraint system cannot be securely restrained and this may cause death or serious injuries in the event of sudden braking, sudden swerving or an accident.

1 When using the LATCH system, move the seat as far back as possible and adjust the seatback as upright as possible.

1 When a booster seat is installed, always ensure that the shoulder belt is positioned across the center of the child's shoulder. The belt should be kept away from the child's neck, but not so that it could fall off the child's shoulder. Failing to do so may result in death or serious injury in the event of sudden braking, sudden swerving or an accident.

 **CAUTION****n When installing a child restraint system**

- I Ensure that the belt and tab are securely locked and the seat belt is not twisted.
- I Push and pull the child restraint system from side to side and forward to be sure it is secure.
- I After securing a child restraint system, never adjust the seat.
- I Follow all installation instructions provided by the child restraint system manufacturer.

**n Do not use a seat belt extender**

If a seat belt extender is used when installing a child restraint system, the seat belt will not securely hold the child restraint system, which could cause death or serious injury to the child or other passengers in the event of sudden braking, sudden swerving or an accident.

**n To correctly attach a child restraint system to the anchors**

When using the LATCH anchors, be sure that there are no foreign objects around the anchors and that the seat belt is not caught behind the child restraint system. Make sure the child restraint system is securely attached, or it may cause death or serious injury to the child or other passengers in the event of a sudden stop, sudden swerve or accident.



## 2-1. Driving procedures

# Driving the vehicle

The following procedures should be observed to ensure safe driving.

### n Starting the engine

→P. 153

### n Driving

**STEP 1** With the brake pedal depressed, shift the shift lever to D.  
(→P. 159)

**STEP 2** Release the parking brake. (→P. 164)

**STEP 3** Gradually release the brake pedal and gently depress the accelerator pedal to accelerate the vehicle.

### n Stopping

**STEP 1** With the shift lever in D, depress the brake pedal.

**STEP 2** If necessary, set the parking brake.

If the vehicle is to be stopped for an extended period of time, shift the shift lever to P or N. (→P. 159)

### n Parking the vehicle

**STEP 1** With the shift lever in D, depress the brake pedal.

**STEP 2** Set the parking brake. (→P. 164)

**STEP 3** Shift the shift lever to P. (→P. 159)

If parking on a hill, block the wheels as needed.

**STEP 4** Press the “ENGINE START STOP” switch to stop the engine.

**STEP 5** Lock the door, making sure that you have the electronic key on your person.

## Starting off on a steep uphill

**STEP 1** Make sure that the parking brake is set and shift the shift lever to D.

**STEP 2** Gently depress the accelerator pedal.

**STEP 3** Release the parking brake.



### n **Driving in the rain**

- 1 Drive carefully when it is raining, because visibility will be reduced, the windows may become fogged-up, and the road will be slippery.
- 1 Drive carefully when it starts to rain, because the road surface will be especially slippery.
- 1 Refrain from high speeds when driving on an expressway in the rain, because there may be a layer of water between the tires and the road surface, preventing the steering and brakes from operating properly.

### n **Breaking in your new Lexus**

To extend the life of the vehicle, observing the following precautions is recommended:

- 1 For the first 200 miles (300 km):  
Avoid sudden stops.
- 1 For the first 500 miles (800 km):  
Do not tow a trailer.
- 1 For the first 1000 miles (1600 km):
  - Do not drive at extremely high speeds.
  - Avoid sudden acceleration.
  - Do not drive continuously in low gears.
  - Do not drive at a constant speed for extended periods.

### n **Drum-in-disc type parking brake system**

Your vehicle has a drum-in-disc type parking brake system. This type of brake system needs bedding-down of the brake shoes periodically or whenever the parking brake shoes and/or drum are replaced. Have your Lexus dealer perform the bedding down operation.

### n **Operating your vehicle in a foreign country**

Comply with the relevant vehicle registration laws and confirm the availability of the correct fuel. (→P. 596)

### CAUTION

#### **n When starting the vehicle**

Always keep your foot on the brake pedal while stopped with the engine running. This prevents the vehicle from creeping.

#### **n When driving the vehicle**

- 1** Do not drive if you are unfamiliar with the location of the brake and accelerator pedals to avoid depressing the wrong pedal.
  - Accidentally depressing the accelerator pedal instead of the brake pedal will result in sudden acceleration that may lead to an accident that could result in death or serious injury.
  - When backing up, you may twist your body around, leading to a difficulty in operating the pedals. Make sure to operate the pedals properly.
  - Make sure to keep a correct driving posture even when moving the vehicle only slightly. This allows you to depress the brake and accelerator pedals properly.
  - Depress the brake pedal using your right foot. Depressing the brake pedal using your left foot may delay response in an emergency, resulting in an accident.
- 1** Do not drive the vehicle over or stop the vehicle near flammable materials. The exhaust system and exhaust gases can be extremely hot. These hot parts may cause a fire if there is any flammable material nearby.
- 1** Do not let the vehicle roll backwards while the shift lever is in a driving position, or roll forward while the shift lever is in R. Doing so may cause the engine to stall or lead to poor brake and steering performance, resulting in an accident or damage to the vehicle.
- 1** If the smell of exhaust is noticed inside the vehicle, open the windows and check that the back door is closed. Large amounts of exhaust in the vehicle can cause driver drowsiness and an accident, resulting in death or a serious health hazard. Have the vehicle inspected by your Lexus dealer immediately.
- 1** Do not under any circumstances shift the shift lever to P while the vehicle is moving. Doing so can cause significant damage to the driveline and may result in a loss of vehicle control.

 **CAUTION**

- I** Do not under any circumstances shift the shift lever to R while the vehicle is moving forward.  
Doing so can cause significant damage to the driveline and may result in a loss of vehicle control.
- I** Do not shift the shift lever to N while the vehicle is moving.  
Doing so may cause insufficient engine braking, resulting in an accident.
- I** Do not turn the engine off while driving.  
The power steering and brake booster will not operate properly if the engine is not running.
- I** Use engine braking (downshift) to maintain a safe speed when driving down a steep hill.  
Using the brakes continuously may cause the brakes to overheat and lose effectiveness. (→P. 159)
- I** When stopped on an incline, use the brake pedal and parking brake to prevent the vehicle from rolling backward or forward, causing an accident.
- I** Do not adjust the position of the steering wheel, the seat, or the inside or outside rear view mirrors while driving.  
Doing so may result in a loss of vehicle control that can cause accidents, resulting in death or serious injury.
- I** Always check that all passengers' arms, heads or other parts of their body are not outside the vehicle, as this may result in death or serious injury.
- I** Do not drive in excess of the speed limit. Even if the legal speed limit permits it, do not drive over 85 mph (140 km/h) unless your vehicle has high-speed capability tires. Driving over 85 mph (140 km/h) may result in tire failure, loss of control and possible injury. Be sure to consult a tire dealer to determine whether the tires on your vehicle are high-speed capability tires or not before driving at such speeds.

### CAUTION

#### **n When driving on slippery road surfaces**

- I** Sudden braking, acceleration and steering may cause tire slippage and reduce your ability to control the vehicle, resulting in an accident.
- I** Sudden changes in engine speed, such as engine braking caused by up-shifting and down-shifting, may cause the vehicle to skid, resulting in an accident.
- I** After driving through a puddle, lightly depress the brake pedal to make sure that the brakes are functioning properly. Wet brake pads may prevent the brakes from functioning properly. If the brakes on only one side are wet and not functioning properly, steering control may be affected, resulting in an accident.

#### **n When shifting the shift lever**

Be careful not to shift the shift lever with the accelerator pedal depressed. This may lead to unexpected rapid acceleration of the vehicle that may cause an accident and result in death or serious injury.

#### **n When the vehicle is stopped**

- I** Do not race the engine.  
If the vehicle is in any gear other than P or N, the vehicle may accelerate suddenly and unexpectedly, causing an accident.
- I** Do not leave the vehicle with the engine running for a long time.  
If such a situation cannot be avoided, park the vehicle in an open space and check that exhaust fumes do not enter the vehicle interior.
- I** In order to prevent accidents due to the vehicle rolling away, always keep depressing the brake pedal while the engine is running, and apply the parking brake as necessary.
- I** If the vehicle is stopped on an incline, in order to prevent accidents caused by the vehicle rolling forward or backward, always depress the brake pedal and securely apply the parking brake as needed.
- I** Avoid revving or racing the engine.  
Running the engine at high speed while the vehicle is stopped may cause the exhaust system to overheat, which could result in a fire if combustible material is nearby.

 **CAUTION****n When the vehicle is parked**

**I** Do not leave glasses, cigarette lighters, spray cans, or soft drink cans in the vehicle when it is in the sun.

Doing so may result in the following:

- Gas may leak from a cigarette lighter or spray can, and may lead to a fire.
- The temperature inside the vehicle may cause the plastic lenses and plastic material of glasses to deform or crack.
- Soft drink cans may fracture, causing the contents to spray over the interior of the vehicle, and may also cause a short circuit in the vehicle's electrical components.

**I** Do not leave cigarette lighters in the vehicle. If a cigarette lighter is in a place such as the glove box or on the floor, it may be lit accidentally when luggage is loaded or the seat is adjusted, causing a fire.

**I** Do not attach adhesive discs to the windshield or windows. Do not place containers such as air fresheners on the instrument panel or dashboard. Adhesive discs or containers may act as lenses, causing a fire in the vehicle.

**I** Do not leave a door or window open if the curved glass is coated with a metalized film such as a silver-colored one. Reflected sunlight may cause the glass to act as a lens, causing a fire.

**I** Always apply the parking brake, shift the shift lever to P, stop the engine and lock the vehicle.

Do not leave the vehicle unattended while the engine is running.

**I** Do not touch the exhaust pipes while the engine is running or immediately after turning the engine off.

Doing so may cause burns.

**I** Do not leave the engine running in an area with snow build-up, or where it is snowing. If snowbanks build up around the vehicle while the engine is running, exhaust gases may collect and enter the vehicle. This may lead to death or a serious health hazard.

**n Exhaust gases**

Exhaust gases include harmful carbon monoxide (CO) that is colorless and odorless. Inhaling exhaust gases may lead to death or a serious health hazard.

### CAUTION

**I** If the vehicle is in a poorly ventilated area, stop the engine. In a closed area, such as a garage, exhaust gases may collect and enter the vehicle. This may lead to death or a serious health hazard.

**I** The exhaust system should be checked occasionally. If there is a hole or crack caused by corrosion, damage to a joint or abnormal exhaust noise, be sure to have the vehicle inspected and repaired by your Lexus dealer. Failure to do so may allow exhaust gases to enter the vehicle, resulting in death or a serious health hazard.

#### **n** When taking a nap in the vehicle

Always turn the engine off. Otherwise, if you accidentally move the shift lever or depress the accelerator pedal, this could cause an accident or fire due to engine overheating. Additionally, if the vehicle is parked in a poorly ventilated area, exhaust gases may collect and enter the vehicle, leading to death or a serious health hazard.

#### **n** When braking the vehicle

**I** When the brakes are wet, drive more cautiously.

Braking distance increases when the brakes are wet, and this may cause one side of the vehicle to brake differently than the other side. Also, the parking brake may not securely hold the vehicle.

**I** If the power brake assist function does not operate, do not follow other vehicles closely and avoid hills or sharp turns that require braking.

In this case, braking is still possible, but the brake pedal should be depressed more firmly than usual. Also, the braking distance will increase.

**I** Do not pump the brake pedal if the engine stalls.

Each push on the brake pedal uses up the reserve for the power-assisted brakes.

**I** The brake system consists of 2 individual hydraulic systems: if one of the systems fails, the other will still operate. In this case, the brake pedal should be depressed more firmly than usual and the braking distance will increase.

If this happens, do not drive the vehicle. Have your brakes fixed immediately.

#### **n** If the vehicle becomes stuck

Do not spin the wheels excessively when any of the tires is up in the air, or the vehicle is stuck in sand, mud, etc. This may damage the driveline components or propel the vehicle forward or backward, causing an accident.

 NOTICE

**n When driving the vehicle**

- 1 Do not depress the accelerator and brake pedals at the same time during driving. If the brake pedal is depressed while driving with the accelerator pedal depressed, driving torque may be restrained.
- 1 Do not use the accelerator pedal or depress the accelerator and brake pedals at the same time to hold the vehicle on a hill.

**n When parking the vehicle**

Always shift the shift lever to P. Failure to do so may cause the vehicle to move or the vehicle may accelerate suddenly if the accelerator pedal is accidentally depressed.

**n Avoiding damage to vehicle parts**

- 1 Do not turn the steering wheel fully in either direction and hold it there for an extended period of time.  
Doing so may damage the power steering motor.
- 1 When driving over bumps in the road, drive as slowly as possible to avoid damaging the wheels, underside of the vehicle, etc.

**n If you hear a squealing or scraping noise (brake pad wear limit indicators)**

Have your Lexus dealer check and replace the brake pads as soon as possible. The rotor damage can result if the pads are not replaced when needed.

It is dangerous to drive the vehicle when the wear limits of the brake pads and/or those of the brake discs are exceeded.

**n If you get a flat tire while driving**

A flat or damaged tire may cause the following situations. Hold the steering wheel firmly and gradually depress the brake pedal to slow down the vehicle.

- 1 It may be difficult to control your vehicle.
- 1 The vehicle will make abnormal sounds.
- 1 The vehicle will behave abnormally.

Information on what to do in case of a flat tire (→P. 564)

### NOTICE

#### **n When encountering flooded roads**

Do not drive on a road that has flooded after heavy rain etc. Doing so may cause the following serious damage to the vehicle:

- I Engine stalling
- I Short in electrical components
- I Engine damage caused by water immersion

In the event that you drive on a flooded road and the vehicle is flooded, be sure to have your Lexus dealer check the following:

- I Brake function
- I Changes in quantity and quality of oil and fluid used for the engine, transaxle, transfer (AWD models), differential, etc.
- I Lubricant condition for the propeller shaft (AWD models), bearings and suspension joints (where possible) and the function of all joints, bearings, etc.



## 2-1. Driving procedures

# Engine (ignition) switch

Performing the following operations when carrying the electronic key on your person starts the engine or changes “ENGINE START STOP” switch modes.

### n Starting the engine

**STEP 1** Check that the parking brake is set.

**STEP 2** Check that the shift lever is set in P.

**STEP 3** Firmly depress the brake pedal.

The “ENGINE START STOP” switch indicator will turn green. If the indicator does not turn green, the engine cannot be started.



Press the “ENGINE START STOP” switch.

The engine will crank until it starts or for up to 30 seconds, whichever is less.

Continue depressing the brake pedal until the engine is completely started.

The engine can be started from any mode.

### n Stopping the engine

**STEP 1** Stop the vehicle.

**STEP 2** Shift the shift lever to P.

**STEP 3** Set the parking brake. (→P. 164)

**STEP 4** Press the “ENGINE START STOP” switch.

**STEP 5** Release the brake pedal and check that the indicator on the “ENGINE START STOP” switch is off.

## n Changing “ENGINE START STOP” switch modes

Modes can be changed by pressing the “ENGINE START STOP” switch with the brake pedal released. (The mode changes each time the switch is pressed.)

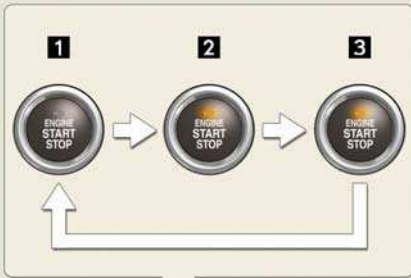

### 1 OFF\*

The emergency flashers can be used.

### 2 ACCESSORY mode

Some electrical components such as the audio system can be used.

The “ENGINE START STOP” switch indicator turns amber.

### 3 IGNITION ON mode

All electrical components can be used.

The “ENGINE START STOP” switch indicator turns amber.

\*: If the shift lever is in a position other than P when turning off the engine, the “ENGINE START STOP” switch will be turned to ACCESSORY mode, not to OFF.

### When stopping the engine with the shift lever in a position other than P

If the engine is stopped with the shift lever in a position other than P, the “ENGINE START STOP” switch will not be turned off but instead be turned to ACCESSORY mode. Perform the following procedure to turn the switch off:

**STEP 1** Check that the parking brake is set.

**STEP 2** Shift the shift lever to P.

**STEP 3** Check that the indicator on the “ENGINE START STOP” switch is illuminated in amber and then press the “ENGINE START STOP” switch once.

**STEP 4** Check that the indicator on the “ENGINE START STOP” switch is off.

#### n Auto power off function

When the shift lever is in P, if the vehicle is left in ACCESSORY or IGNITION ON mode with the engine not running for more than 20 minutes (ACCESSORY mode) or one hour (IGNITION ON mode), the “ENGINE START STOP” switch will automatically turn off. However, this function cannot entirely prevent battery discharge. Do not leave the vehicle with the “ENGINE START STOP” switch in ACCESSORY or IGNITION ON mode for long periods of time when the engine is not running.

#### n Operation of the “ENGINE START STOP” switch

When operating the “ENGINE START STOP” switch, one short, firm press is enough. If the switch is pressed improperly, the engine may not start or the “ENGINE START STOP” switch mode may not change. It is not necessary to press and hold the switch.

#### n Electronic key battery depletion

→P. 39

#### n Conditions affecting operation

→P. 36

#### n Note for the entry function

→P. 31

### ■ If the engine does not start

The engine immobilizer system may not have been deactivated. (→P. 101)

### ■ Steering lock

After turning the “ENGINE START STOP” switch off and opening and closing the doors, the steering wheel will be locked due to the steering lock function. Operating the “ENGINE START STOP” switch again automatically cancels the steering lock.

### ■ When the steering lock cannot be released



The green indicator light on the “ENGINE START STOP” switch will flash and a message will be shown on the multi-information display. Press the “ENGINE START STOP” switch again while turning the steering wheel left and right.

### ■ Steering lock motor overheating prevention

To prevent the steering lock motor from overheating, the motor may be suspended if the engine is turned on and off repeatedly in a short period of time. In this case, refrain from operating the engine. After about 2 seconds, the steering lock motor will resume functioning.

### ■ When the “ENGINE START STOP” switch indicator flashes in amber

The system may be malfunctioning. Have the vehicle inspected by your Lexus dealer immediately.

### ■ If the electronic key battery is depleted

→P. 496

 **CAUTION****n When starting the engine**

Always start the engine while sitting in the driver's seat. Do not depress the accelerator pedal while starting the engine under any circumstances.

Doing so may cause an accident resulting in death or serious injury.

**n Caution while driving**

If the vehicle begins to slide due to engine failure or other circumstances, do not lock or open the doors until the vehicle reaches a safe and complete stop. Activation of the steering lock in this circumstance may lead to an accident, resulting in death or serious injury.

**n Stopping the engine in an emergency**

If you want to stop the engine in an emergency while driving the vehicle, press and hold the "ENGINE START STOP" switch for more than 3 seconds.

However, do not touch the "ENGINE START STOP" switch while driving unless in an emergency. If the engine stops while driving, this could lead to an accident.

### NOTICE

#### **n To prevent battery discharge**

- l** Do not leave the “ENGINE START STOP” switch in ACCESSORY or IGNITION ON mode for long periods of time without the engine running.
- l** If the indicator on the “ENGINE START STOP” switch is illuminated, the “ENGINE START STOP” switch is not off. When exiting the vehicle, always check that the “ENGINE START STOP” switch is off.
- l** Do not stop the engine when the shift lever is in a position other than P. If the engine is stopped in another shift lever position, the “ENGINE START STOP” switch will not be turned off but instead be turned to ACCESSORY mode. If the vehicle is left in ACCESSORY mode, battery discharge may occur.

#### **n When starting the engine**

- l** Do not race a cold engine.
- l** If the engine becomes difficult to start or stalls frequently, have the engine checked immediately.

#### **n Symptoms indicating a malfunction with the “ENGINE START STOP” switch**

If the “ENGINE START STOP” seems to be operating somewhat differently than usual, such as the switch sticking slightly, there may be a malfunction. Contact your Lexus dealer immediately.

## 2-1. Driving procedures

# Automatic transmission

Select a shift position appropriate for the driving conditions.

### n Shifting the shift lever



← While the “ENGINE START STOP” switch is in IGNITION ON mode, depress the brake pedal and move the shift lever.

### n Shift position purpose

Shift position	Function
P	Parking the vehicle/starting the engine
R	Reversing
N	Neutral
D	Normal driving <sup>*1</sup>
S	S mode driving <sup>*2</sup> (→P.161)

\*1: Shifting to the D position allows the system to select a gear suitable for the driving conditions. Setting the shift lever to the D position is recommended for normal driving.

\*2: Selecting shift ranges using S mode restricts the upper limit of the possible gear ranges, controls engine braking forces, and prevents unnecessary upshifting.

### n Selecting snow mode

Use snow mode for accelerating and driving on slippery road surfaces such as snow.



- 1 Press the menu switch.

The multi-information display will change modes to electronic features control mode.

- 2 Press the "ENTER" switch upwards or downwards until "ECT SNOW" appears.



Press the "ENTER" switch to change to "ON". The "ECT SNOW" indicator will be displayed.

Each pressing of the switch turns snow mode on and off.

Press the menu switch to change to the normal display.



## Changing shift ranges in S mode

When the shift lever is in the S position, the shift lever can be operated as follows:

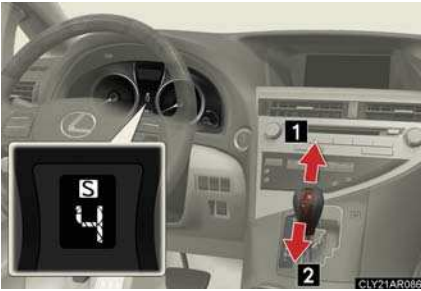

- 1 For upshifting
- 2 For downshifting

The initial shift range in S mode is set automatically to “5” or “4” according to vehicle speed. However, the initial shift range may be set to “3” if AI-SHIFT has operated while the shift lever was in the D position. (→P. 162)

### n Shift ranges and their functions

- 1 You can choose from 6 levels of engine braking force.
- 1 A lower shift range will provide greater engine braking force than a higher shift range, and the engine speed will also increase.

### ■ **Snow mode automatic deactivation**

Snow mode is automatically deactivated if the “ENGINE START STOP” switch is turned off after driving in snow mode.

### ■ **S mode**

1 When the shift range is “5” or lower, holding the shift lever toward “+” sets the shift range to “6”.

1 To prevent the engine from over-revving, upshifting may automatically occur.

1 To protect the automatic transmission, a function is adopted that automatically selects a higher shift range when the fluid temperature is high.

### ■ **AI-SHIFT**

AI-SHIFT automatically selects the optimal gear according to driver performance and driving conditions.

AI-SHIFT automatically operates when the shift lever is in the D position. (Shifting the shift lever to the S position cancels the function.)

### ■ **When driving with the cruise control or dynamic radar cruise control**

Engine braking will not occur in S mode, even when downshifting to “5” or “4”. (→P. 204, 208)

### ■ **If the shift lever cannot be shifted from P**

→P. 579

### ■ **If S does not come on even after shifting the shift lever to S**

This may indicate a malfunction in the automatic transmission system. Have the vehicle inspected by your Lexus dealer immediately.

(In this situation, the transmission will operate in the same as manner as when the shift lever is in D.)

### ■ **Downshift restriction warning buzzer (S mode)**

To help ensure safety and driving performance, downshifting operation may sometimes be restricted. In some circumstances, downshifting may not be possible even when the shift lever is operated. (The buzzer will sound twice.)

## 2-1. Driving procedures

### Turn signal lever

The turn signal lever can be used to show the following intention of the driver:

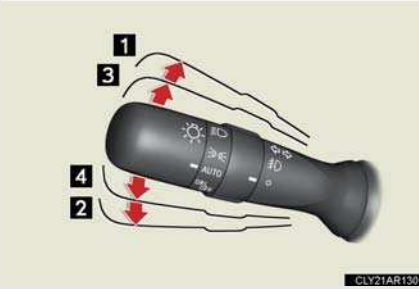
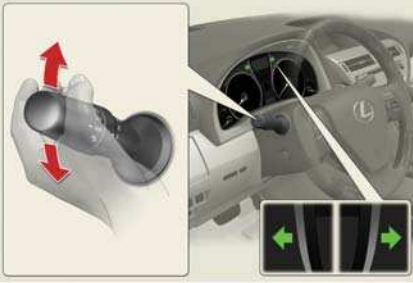

- 1 Right turn
- 2 Left turn
- 3 Lane change to the right (push and hold the lever part-way)

The right hand signals will flash until you release the lever.

- 4 Lane change to the left (push and hold the lever part-way)

The left hand signals will flash until you release the lever.

#### n Turn signals can be operated when

The "ENGINE START STOP" switch is in IGNITION ON mode.

#### n If the indicators flash faster than usual

Check that a light bulb in the front or rear turn signal lights has not burned out.

## 2-1. Driving procedures

### Parking brake



To set the parking brake, fully depress the parking brake pedal with your left foot while depressing the brake pedal with your right foot.

(Depressing the pedal again releases the parking brake.)

#### n Usage in winter time

See "Winter driving tips" for parking brake usage in winter time. (→P. 254)

#### NOTICE

#### n Before driving

Fully release the parking brake.

Driving the vehicle with the parking brake set will lead to brake components overheating, which may affect braking performance and increase brake wear.

## 2-1. Driving procedures

# Horn



To sound the horn, press on or close to the  mark.

## 2-2. Instrument cluster

# Gauges and meters

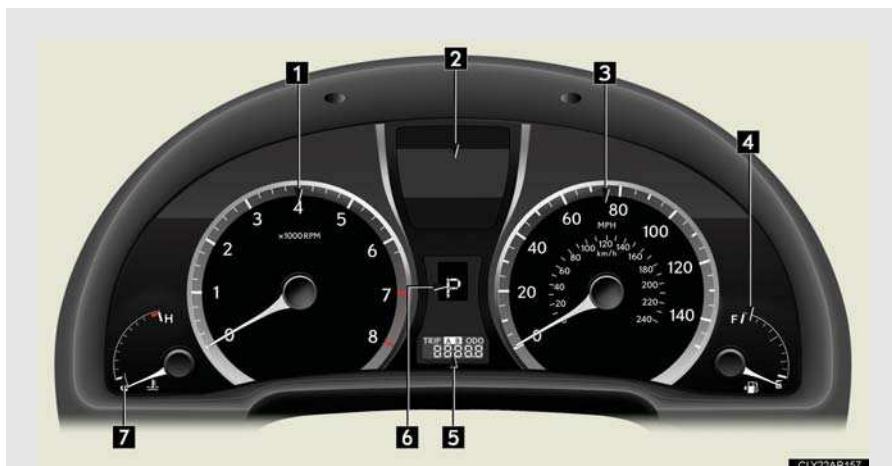

### 1 Tachometer

Displays the engine speed in revolutions per minute

### 2 Multi-information display

→P.173

### 3 Speedometer

Displays the vehicle speed

### 4 Fuel gauge

Displays the quantity of fuel remaining in the tank

### 5 Odometer and trip meter

Odometer: Displays the total distance the vehicle has been driven

Trip meter: Displays the distance the vehicle has been driven since the meter was last reset. Trip meters "A" and "B" can be used to record and display different distances independently.

### 6 Automatic transmission shift position indicator

→P.159

### 7 Engine coolant temperature gauge

Displays the engine coolant temperature

## Changing the display



Switches between odometer and trip meter displays. When the trip meter is displayed, pressing and holding the button will reset the trip meter.

## Instrument panel light control buttons

The brightness of the instrument panel lights can be adjusted.



- 1 Darker
- 2 Brighter

### n The meters and display illuminate when

The "ENGINE START STOP" switch is in IGNITION ON mode.

### ⚠ NOTICE

#### n To prevent damage to the engine and its components

- 1 Do not let the indicator needle of the tachometer enter the red zone, which indicates the maximum engine speed.
- 1 The engine may be overheating if the engine coolant temperature gauge is in the red zone (H). In this case, immediately stop the vehicle in a safe place, and check the engine after it has cooled completely. (→P. 587)

## 2-2. Instrument cluster

### Indicators and warning lights

The indicator and warning lights on the instrument cluster and center panel inform the driver of the status of the vehicle's various systems.

#### ► Instrument cluster



CLY22AR392

#### ► Center panel (without navigation system)



CLY22AR042



► Center panel (with navigation system)



## n Indicators

The indicators inform the driver of the operating state of the vehicle's various systems.



Turn signal indicator  
(→P. 163)



(if equipped)

Intuitive parking assist indicator (→P. 220)



Headlight high beam indicator (→P. 186)



(if equipped)

\*<sub>1</sub>  
"AFS OFF" indicator  
(→P. 186)



(if equipped)

\*<sub>1</sub>  
Automatic High Beam indicator (→P. 189)



\*<sub>1,2</sub>  
Slip indicator  
(→P. 232)



(U.S.A.)

Headlight indicator  
(→P. 184)



\*<sub>1</sub>  
VSC off indicator  
(→P. 233)



(Canada)

Tail light indicator  
(→P. 184)



(AWD models only)

\*<sub>1</sub>  
All-wheel drive lock indicator  
(→P. 237)



Front fog light indicator  
(→P. 195)



"ECT SNOW" indicator  
(→P. 160)



Cruise control indicator  
(→P. 204, 208)



(if equipped)

Radar cruise control indicator (→P. 208)



(with navigation system)

<sup>\*1</sup> SRS airbag on-off indicator (→P.122)



(without navigation system)

<sup>\*1</sup> SRS airbag on-off indicator (→P.122)



<sup>\*1</sup> Eco Driving Indicator Light (→P.177)

<sup>\*1</sup>: These lights turn on when the "ENGINE START STOP" switch is turned to IGNITION ON mode to indicate that a system check is being performed. They will turn off after the engine is started, or after a few seconds. There may be a malfunction in a system if a light does not come on, or if the lights do not turn off. Have the vehicle inspected by your Lexus dealer, for details.

<sup>\*2</sup>: The light flashes to indicate that the system is operating.

**n Warning lights**

Warning lights inform the driver of malfunctions in any of the vehicle's systems. (→P. 535)

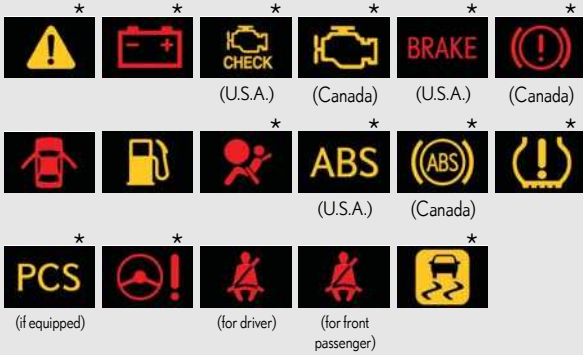

\*: These lights turn on when the “ENGINE START STOP” switch is turned to IGNITION ON mode to indicate that a system check is being performed. They will turn off after the engine is started, or after a few seconds. There may be a malfunction in a system if a light does not come on, or if the lights do not turn off. Have the vehicle inspected by your Lexus dealer, for details.

**! CAUTION**

**n If a safety system warning light does not come on**

Should a safety system light such as the ABS and SRS airbag warning light not come on when you start the engine, this could mean that these systems are not available to help protect you in an accident, which could result in death or serious injury. Have the vehicle inspected by your Lexus dealer immediately if this occurs.

# Multi-information display

The multi-information display presents the driver with a variety of driving-related data including the current outside air temperature.

### n Multi-information Switches

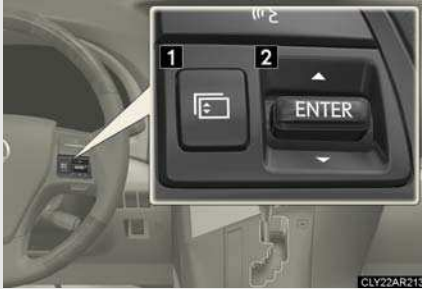

#### 1 Menu switch

Changes modes to electronic features control mode, customization mode or back to normal display mode

#### 2 "ENTER" switch

Changes trip information items. This switch is also used to turn on/off electronic features controls and to change customization settings.

n Display contents

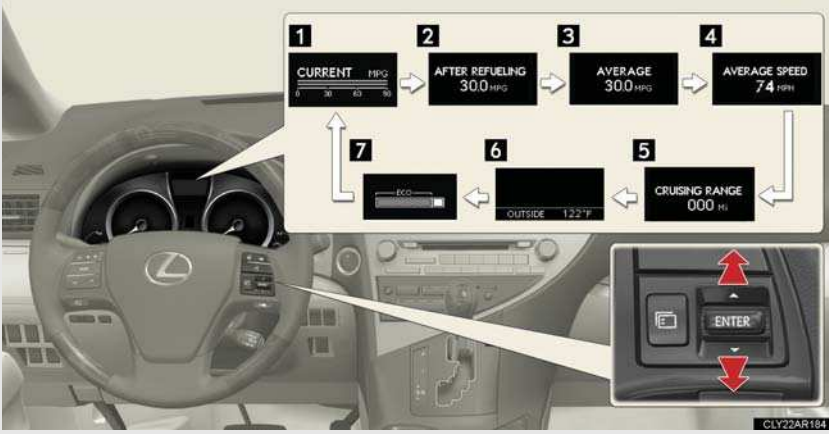

Trip information contents	Switching display items
1 Current fuel consumption	Pressing the “ENTER” switch upwards or downwards.
2 Average fuel consumption after refueling	
3 Average fuel consumption	
4 Average vehicle speed	
5 Cruising range	
6 Multi-information display OFF	
7 Eco Driving Indicator Zone Display	

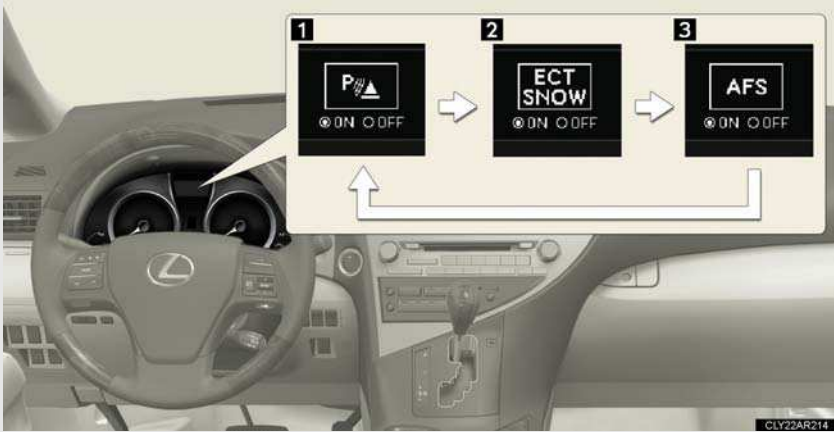

## Electronic features control contents

**1** Intuitive parking assist  
(if equipped)

**2** Snow mode

**3** AFS (if equipped)

## Setting electronic features controls

→P. 220

→P. 160

→P. 186

Other contents	Details
Outside temperature	Displays the outside temperature
Dynamic radar cruise control display (if equipped) (→P. 208)	Automatically displayed when using dynamic radar cruise control
Customization (→P. 621)	Settings of functions such as the door lock and light illumination time can be changed
Warning message (→P. 545)	Automatically displayed when a malfunction occurs in one of the vehicle's systems

## Trip information

### **n** Current fuel consumption

Displays the current rate of fuel consumption

### **n** Average fuel consumption after refueling

Displays the average fuel consumption since the vehicle was last refueled

### **n** Average fuel consumption

Displays the average fuel consumption since the function was reset

The function can be reset by pushing the “ENTER” switch for longer than one second when the average fuel consumption is displayed.

### **n** Average vehicle speed

Displays the average vehicle speed since the function was reset

The function can be reset by pushing the “ENTER” switch for longer than one second when the average vehicle speed is displayed.

### **n** Cruising range

Displays the estimated maximum distance that can be driven with the quantity of fuel remaining

- This distance is computed based on your average fuel consumption. As a result, the actual distance that can be driven may differ from that displayed.
- When only a small amount of fuel is added to the tank, the display may not be updated.

### **n** Eco Driving Indicator Zone Display

→P.177



### n Electronic features control can be turned on/off when

The "ENGINE START STOP" switch is in IGNITION ON mode.

### n Conditions for ending electronic features control

In the following situations, the electronic features control will end automatically:

- 1 The menu switch is pressed
- 1 The radar cruise control is operated
- 1 Intuitive parking assist starts operating
- 1 No action is performed for some time after the electronic features control screen is displayed
- 1 A warning message appears after the electronic features control screen is displayed

### n Eco Driving Indicator

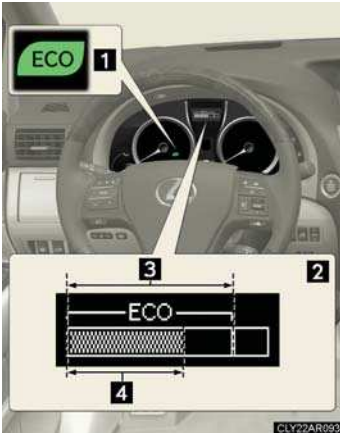

#### 1 Eco Driving Indicator Light

During Eco-friendly acceleration (Eco driving), Eco Driving Indicator Light will turn on.

#### 2 Eco Driving Indicator Zone Display

Suggests Eco driving range with current Eco driving ratio based on acceleration.

#### 3 Zone of Eco driving

#### 4 Eco driving ratio based on acceleration

If Zone of Eco driving is exceeded, the right of Eco Driving Indicator Zone Display will blink and Eco Driving Indicator Light will turn off.

Eco Driving Indicator will operate when the vehicle is being driven with the shift lever in D. Eco Driving Indicator will not operate when the vehicle is in ECT SNOW mode.

### n **Outside temperature display**

In the following situations, the correct outside temperature may not be displayed, or the display may take longer than normal to change.

- l When stopped, or driving at low speeds (less than 15 mph [25 km/h])
- l When the outside temperature has changed suddenly (at the entrance/exit of a garage, tunnel, etc.)

### n **Customization**

Settings (e.g. available languages) can be changed.  
(Customizable features →P. 621)

### **CAUTION**

#### n **Caution while driving**

When operating the electronic features control while driving, take extra notice of the vehicle's surrounding area.

### **NOTICE**

#### n **The multi-information display at low temperatures**

Allow the interior of the vehicle to warm up before using the liquid crystal information display. At extremely low temperatures, the information display monitor may respond slowly, and display changes may be delayed.

## 2-2. Instrument cluster Head-up display\*

The head-up display can be used to project vehicle speed and other information onto the windshield.



### 1 Head-up display

Display brightness will change automatically according to the brightness of the surrounding area.

### 2 Head-up display main switch

### 3 Display contrast adjustment switch

Display brightness can be adjusted to the desired level.

### 4 Display position adjustment switch

\*: If equipped

### n Head-up display contents

In addition to vehicle speed, the following information will be displayed:

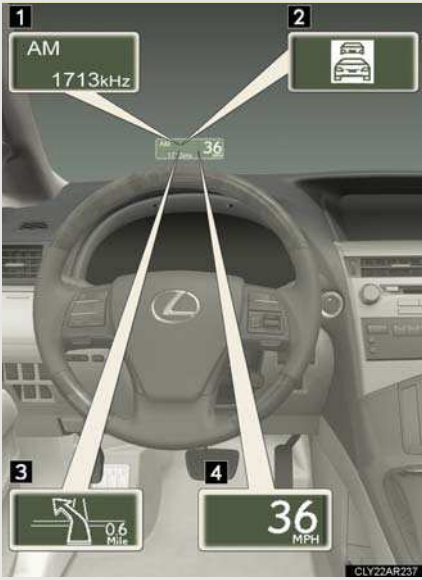

#### 1 Audio display

Displays audio information for approximately 3 seconds when the audio system is operated

#### 2 Dynamic radar cruise control (if equipped)

Displays the approach warning message (→P. 551)

#### 3 Turn-by-turn navigation\*

Displays a notification of upcoming intersections during navigation system route guidance

#### 4 Vehicle speed display

\*: Refer to “Navigation System Owner’s Manual”.

## Head-up display main switch



Pressing the switch turns the head-up display on/off and changes the vehicle speed display units as follows:

- ▶ Vehicles sold in the U.S.A.  
OFF → ON (mph) → ON (km/h) → OFF
- ▶ Except vehicles sold in the U.S.A.  
OFF → ON (km/h) → ON (mph) → OFF

2

When driving

## Display adjustment

- ▶ Adjusting display contrast

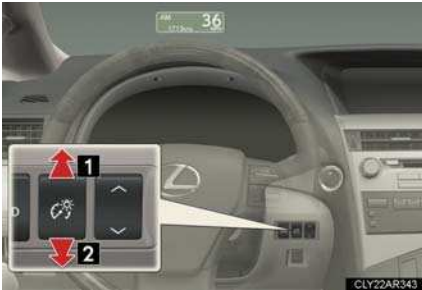

- 1 Brighter
- 2 Darker

- ▶ Adjusting display position



- 1 Higher
- 2 Lower

### Display customization

The audio mode display can be shown or hidden.



Pressing and holding the head-up display main switch for more than 2 seconds changes the display to audio display on/off mode. Press the head-up display main switch to turn the audio display on/off.

Customization can be performed when the head-up display is on and the vehicle is traveling at less than 5 mph (8 km/h).

#### n Brightness of the head-up display

The headlight control sensor detects the brightness of the area surrounding the head-up display and adjusts the brightness accordingly. (→P. 187)

#### n Head-up display

The head-up display may seem dark and hard to see when viewed through sunglasses, especially polarized sunglasses.

Adjust the brightness of the head-up display or remove your sunglasses.

### ⚠ CAUTION

#### n Before using the head-up display

Check that the position and brightness of the head-up display image does not interfere with safe driving. Incorrect adjustment of the image's position or brightness may obstruct the driver's view and lead to an accident, resulting in death or serious injury.

 NOTICE**n To prevent damage to components**

If an object falls into the opening of the head-up display, remove it immediately. Also, avoid spilling water or other liquids near the head-up display opening as this may cause mechanical damage.



## 2-3. Operating the lights and windshield wipers

### Headlight switch

The headlights can be operated manually or automatically.

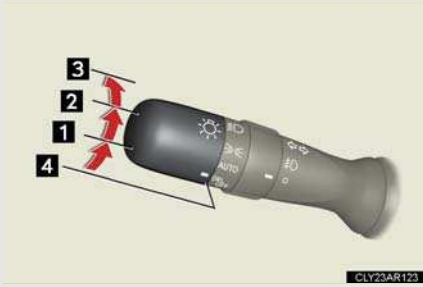
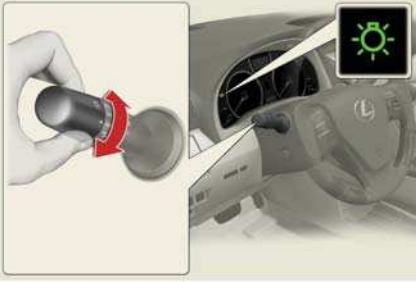
► U.S.A.





- 1 AUTO** The headlights and side marker, parking, tail, license plate, daytime running lights and instrument panel lights turn on and off automatically (when the “ENGINE START STOP” switch is in IGNITION ON mode).
- 2**  The side marker, parking, tail, license plate, daytime running lights and instrument panel lights turn on.
- 3**  The headlights and all the lights listed above (except daytime running lights) turn on.
- 4**  The daytime running lights turn off.

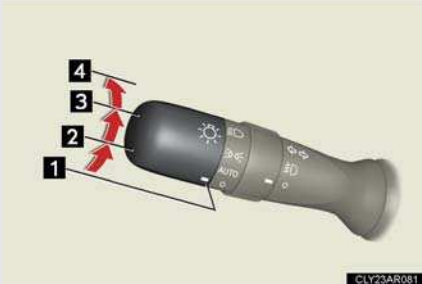
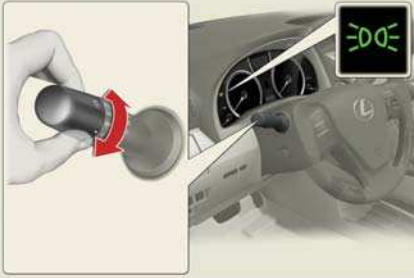

## ► Canada



- 1  The daytime running lights turn on.
- 2 **AUTO** The headlights and side marker, parking, tail, license plate, daytime running lights and instrument panel lights turn on and off automatically (when the "ENGINE START STOP" switch is in IGNITION ON mode).
- 3  The side marker, parking, tail, license plate, daytime running lights and instrument panel lights turn on.
- 4  The headlights and all the lights listed above (except daytime running lights) turn on.

### Turning on the high beam headlights

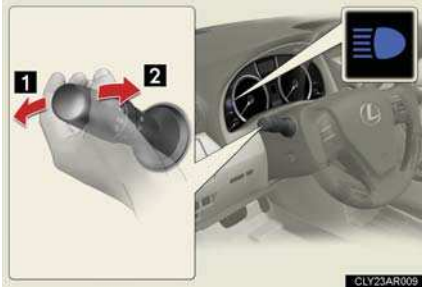

- 1 With the headlights on, push the lever away from you to turn on the high beams.

When the light switch is in "AUTO" position, the Automatic High Beam system will be activated. (→P.189)

Pull the lever toward you to the center position to turn the high beams off.

- 2 Pull the lever toward you to turn on the high beams.

Release to turn them off. You can flash the high beams with the headlights on or off.

### AFS (Adaptive Front-lighting System) (if equipped)

AFS (Adaptive Front-lighting System) improves visibility at intersections and on curves by automatically adjusting the direction of the light axis of the headlights according to vehicle speed and the degree of the tire angle that are controlled by steering input.

AFS operates at speeds of 6 mph (10 km/h) or higher.

#### n Deactivating AFS



- 1 Press the menu switch.

The multi-information display will change modes to electronic features control mode.

- 2 Press the "ENTER" switch upwards or downwards until "AFS" appears.



Press the “ENTER” switch to change to “OFF”. The “AFS OFF” indicator will be displayed.

Each pressing of the switch turns “AFS” on and off.

Press the menu switch to change to the normal display.

2

When driving

### n Daytime running light system

- 1 To make your vehicle more visible to other drivers, the daytime running lights turn on automatically whenever the engine is started and the parking brake is released. Daytime running lights are not designed for use at night.  
For the U.S.A.: Daytime running lights can be turned off by operating the switch.
- 1 Compared to turning on the headlights, the daytime running light system offers greater durability and consumes less electricity, so it can help improve fuel economy.

### n Headlight control sensor





The sensor may not function properly if an object is placed on the sensor, or anything that blocks the sensor is affixed to the windshield.

Doing so interferes with the sensor detecting the level of ambient light and may cause the automatic headlight system to malfunction.

### n Automatic light off system

- 1 When the headlights come on: The headlights and tail lights turn off 30 seconds after a door is opened and closed if the “ENGINE START STOP” switch is turned to ACCESSORY mode or turned off. (The lights turn off immediately if  on the key is pressed after all the doors are locked.)
- 1 When only the tail lights come on: The tail lights turn off automatically if the “ENGINE START STOP” switch is turned to ACCESSORY mode or turned off and the driver’s door is opened.

To turn the lights on again, turn the “ENGINE START STOP” switch to IGNITION ON mode, or turn the light switch off once and then back to  or .

### n Automatic headlight leveling system (if equipped)

The level of the headlights is automatically adjusted according to the number of passengers and the loading condition of the vehicle to ensure that the headlights do not interfere with other road users.

### n If the “AFS OFF” indicator flashes

It may indicate a malfunction in the system. Contact your Lexus dealer.

### n Customization

Settings (e.g. light sensor sensitivity) can be changed.  
(Customizable features →P. 621)

### NOTICE

### n To prevent the battery discharge

Do not leave the lights on longer than necessary when the engine is not running.

## 2-3. Operating the lights and windshield wipers

### Automatic High Beam\*

The Automatic High Beam uses an in-vehicle camera sensor to assess the brightness of streetlights, the lights of oncoming and preceding vehicles, etc., and automatically turns high beam on or off as necessary.

#### n Activating the Automatic High Beam system

STEP 1

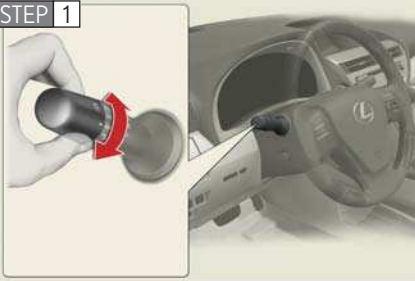

Head light switch in "AUTO" position.

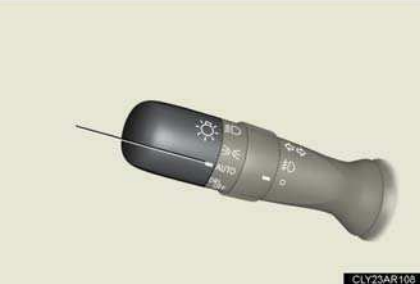

CLY23AR106

STEP 2

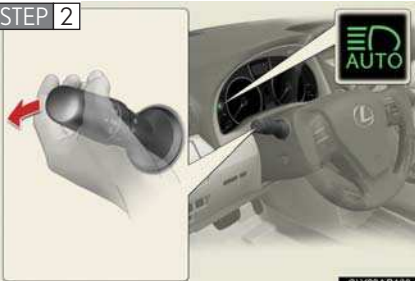

Push the lever away from you.

The Automatic High Beam indicator will come on when the headlights are turned on automatically to indicate that the system is active.

### n Turning the high beam on/off manually

#### ► Switching to low beam

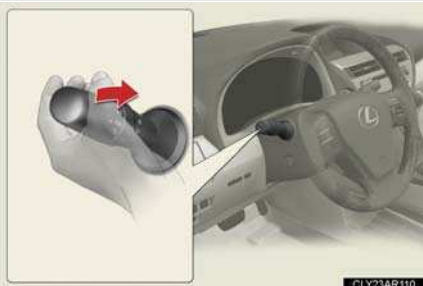

Pull the lever to original position.

#### ► Switching to high beam

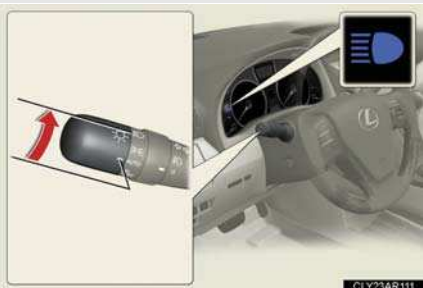

Turn the light switch to  position.

**n High beam automatic turning on or off conditions**

When all of the following conditions are fulfilled, high beam will be automatically turned on (after approximately 1 second):

- 1 Vehicle speed is above approximately 20 mph (32 km/h).
- 1 The area ahead of the vehicle is dark.
- 1 There are no oncoming or preceding vehicles with headlights or tail lights turned on.

If any of the following conditions are fulfilled, high beam will be automatically turned off:

- 1 Vehicle speed drops below approximately 20 mph (32 km/h).
- 1 The area ahead of the vehicle is not dark.
- 1 Oncoming or preceding vehicles have headlights or tail lights turned on.

**n The Automatic High Beam can be operated when**

The “ENGINE START STOP” switch is IGNITION ON mode.

**n Limitations of the Automatic High Beam**

Do not rely on the Automatic High Beam. Always drive safely, taking care to observe your surroundings and turning high beam on or off manually if necessary.

**n Camera sensor detection information**

- 1 High beam may not be automatically turned off in the following situations:
  - When oncoming vehicles suddenly appear from a curve.
  - When the vehicle is cut in front of by another.
- 1 High beam may be turned off if an oncoming vehicle that is using fog lights without using the headlights is detected.
- 1 House lights, street lights, red traffic signals, and illuminated billboards or signs may cause the high beam to turn off.

## 2-3. Operating the lights and windshield wipers

- 1 The following factors may affect the amount of time taken to turn high beam on or off:
  - The brightness of headlights, fog lights, and tail lights of oncoming and preceding vehicles
  - Road conditions (wetness, ice, snow etc.)
  - The number of passengers and amount of baggage
- 1 High beam may be turned on or off when unexpected by the driver.
- 1 In the situations below, the system may not be able to correctly detect the surrounding brightness levels, and may flash or expose nearby pedestrians to the high beam. Therefore, you should consider turning the high beams on or off manually rather than relying on the Automatic High Beam System.
  - In bad weather (rain, snow, fog, sandstorms etc.)
  - The windshield is obscured by fog, mist, ice, dirt etc.
  - The windshield is cracked or damaged.
  - The inside rear view mirror or camera sensor is deformed or dirty.
  - Surrounding brightness levels are equal to those of headlights, tail lights or fog lights.
  - Vehicles ahead have headlights that are either switched off, dirty, are changing color, or have are not aimed properly.
  - When driving through an area of intermittently changing brightness and darkness
  - When frequently and repeatedly driving ascending/descending roads, or roads with rough, bumpy or uneven surfaces (such as stone-paved roads, gravel tracks etc.)
  - When frequently and repeatedly taking curves or driving on a winding road
  - There is a highly reflective object ahead of the vehicle, such as a sign or a mirror.
  - The vehicle's headlights are damaged or dirty.
  - The vehicle is listing or tilting, due to a flat tire, a trailer being towed etc.
  - The Automatic High Beam indicator is flashing.
  - The high beam and low beam are repeatedly being switched between in an abnormal manner.
  - The driver believes that the high beam may be causing problems or distress to other drivers or pedestrians nearby.



### n **If the Automatic High Beam indicator flashes**

It may indicate a malfunction in the system. Contact your Lexus dealer.

### n **Temporary lowering sensor sensitivity**

The sensitivity of the sensor can be temporarily lowered.

To lower the sensitivity, push and hold the “AUTO” button on the inside rear view mirror for 15 to 20 seconds, and release. The indicator light on the inside rear view mirror will flash to indicate that the sensitivity has been lowered.

When the “ENGINE START STOP” switch is turned off, the sensitivity will be returned to its normal level.

### n **Customization that can be configured at your Lexus dealer**

The Automatic High Beam can be turned off.

### NOTICE

#### **n** Notes when using the Automatic High Beam system



Observe the following to ensure that the Automatic High Beam functions correctly.

- 1 Do not touch the camera sensor.
- 1 Do not subject the inside rear view mirror or the camera sensor to a strong impact.
- 1 Do not disassemble the camera sensor.
- 1 Do not spill liquid onto the inside rear view mirror or the camera sensor.
- 1 Do not apply window tinting or stickers to the camera sensor or the area of windshield near the camera sensor.
- 1 Do not place items on the dashboard. There is a possibility that the camera sensor will mistake items reflected in the windshield for streetlights, the headlights of other vehicles, etc.
- 1 Do not install a parking tag or any other accessories near or around the inside rear view mirror and the camera sensor.
- 1 Do not overload the vehicle.
- 1 Do not modify the vehicle.
- 1 Do not replace windshield with non-genuine windshield.  
Contact your Lexus dealer.



## 2-3. Operating the lights and windshield wipers

### Fog light switch

The fog lights improve visibility in difficult driving conditions, such as in rain and fog.

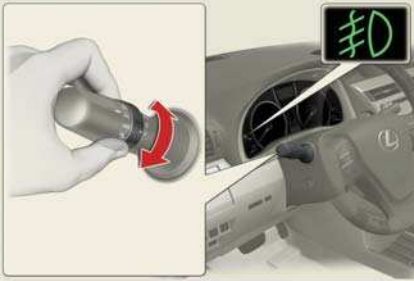
► U.S.A.



- 1  Turns the front fog lights off
- 2  Turns the front fog lights on

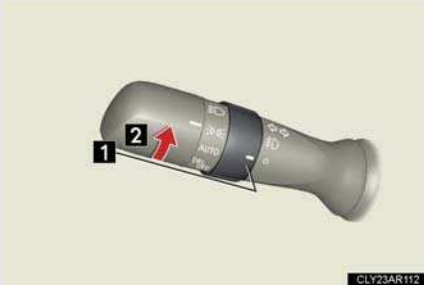

## 2-3. Operating the lights and windshield wipers

### ► Canada

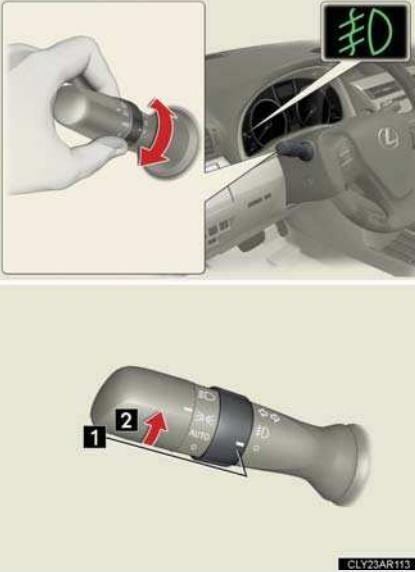

- 1 **0** Turns the front fog lights off
- 2 **1** Turns the front fog lights on

- n Fog lights can be used when  
The head lights are on in low beam.





## 2-3. Operating the lights and windshield wipers

### Windshield wipers and washer

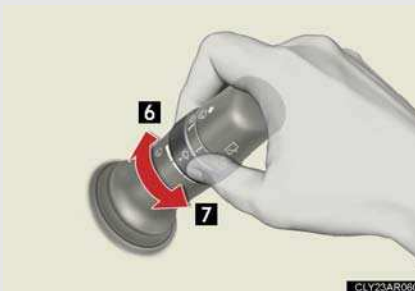
#### ► Intermittent wipers with interval adjuster

When intermittent wiper operation is selected, wiper intervals can be adjusted as follows by turning the switch ring:



- 1  Off
- 2  Intermittent windshield wiper operation
- 3  Low speed windshield wiper operation
- 4  High speed windshield wiper operation
- 5  Temporary operation

- 6 Increases the intermittent windshield wiper frequency
- 7 Decreases the intermittent windshield wiper frequency



### 8 Washer/wiper dual operation

The wipers will automatically operate a couple of times after the washer squirts.





If the headlights are on, the headlight cleaners will operate once.

### ► Rain-sensing windshield wipers

When **AUTO** is selected, the wipers will operate automatically when the sensor detects falling rain. The system automatically adjusts wiper timing in according to rain volume and vehicle speed.

When **AUTO** is selected, the sensor sensitivity can be adjusted as follows by turning the switch ring:



- 1  Off
- 2 **AUTO** Rain-sensing wiper operation
- 3  Low speed wiper operation
- 4  High speed wiper operation
- 5  Temporary operation

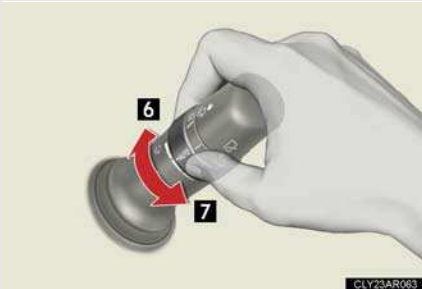

**6** Sensor sensitivity (high)

**7** Sensor sensitivity (low)



**8** Washer/wiper dual operation

The wipers will automatically operate a couple of times after the washer squirts.

(After operating several times, the wipers operate one more time after a short delay to prevent dripping.)

If the headlights are on, the headlight cleaners will operate once.

### n The windshield wipers and washer can be operated when

The “ENGINE START STOP” switch is in IGNITION ON mode.

### n Effects of vehicle speed on wiper operation

Vehicle speed affects the following even when the wipers are not in “AUTO” mode:

1 Intermittent wiper interval

1 Wiper operation when the washer is being used (delay until drip prevention wiper sweep occurs)

When low speed wiper operation is selected, wiper operation will be switched from low speed to intermittent wiper operation only when the vehicle is stationary.

(However, when the sensor sensitivity is adjusted to the highest, the mode cannot be switched.)

## 2-3. Operating the lights and windshield wipers

### n Raindrop sensor (vehicles with rain-sensing windshield wipers)



- 1 The raindrop sensor judges the amount of raindrops.

An optical sensor is adopted. It may not operate properly when sunlight from the rising or setting of the sun intermittently strikes the windshield, or if bugs etc. are present on the windshield.

- 1 If the wiper switch is turned to the **AUTO** position while the “ENGINE START STOP” switch is in IGNITION ON mode, the wipers will operate once to show that “AUTO” mode is activated.
  - 1 When the sensor sensitivity ring is turned toward high while in “AUTO” mode, the wipers will operate once to indicate that the sensor sensitivity is enhanced.
  - 1 If the temperature of the raindrop sensor is 194°F (90°C) or higher, or 5°F (-15°C) or lower, automatic operation may not occur. In this case, operate the wipers in any mode other than “AUTO”.
- n **If no windshield washer fluid sprays**

Check that the washer nozzles are not blocked if there is washer fluid in the windshield washer fluid reservoir.

### ⚠ CAUTION

#### n Caution regarding the use of windshield wipers in “AUTO” mode (vehicles with rain-sensing windshield wipers)

The windshield wipers may operate unexpectedly if the sensor is touched or the windshield is subject to vibration in “AUTO” mode. Take care that your fingers or anything else do not become caught in the windshield wipers.



 NOTICE

**n When the windshield is dry**

Do not use the wipers, as they may damage the windshield.

**n When the washer fluid tank is empty**

Damage to the washer fluid pump may be caused if the lever is pulled toward you and held continually.

**n When a nozzle becomes blocked**





Do not try to clear it with a pin or other object. The nozzle will be damaged.

## 2-3. Operating the lights and windshield wipers

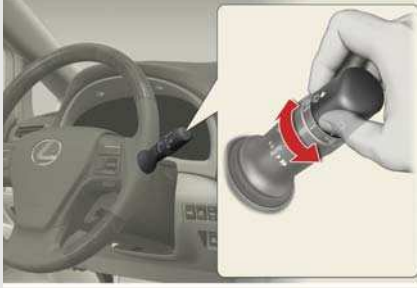
### Rear window wiper and washer

The wiper operation is selected by moving the lever as follows:



- 1  Off
- 2  Intermittent window wiper operation
- 3  Normal window wiper operation
- 4  Washer/wiper dual operation
- 5  Washer/wiper dual operation

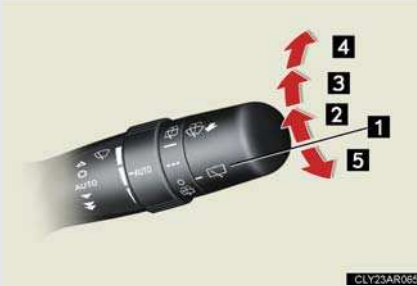

- n **The rear window wiper and washer can be operated when**  
The "ENGINE START STOP" switch is in IGNITION ON mode.

#### NOTICE

- n **When the rear window is dry**  
Do not use the wipers, as they may damage the rear window.
- n **When the washer fluid tank is empty**  
Damage to the washer fluid pump may be caused if the lever is operated continually.
- n **When a nozzle becomes blocked**  
Do not try to clear it with a pin or other object. The nozzle will be damaged.

## 2-3. Operating the lights and windshield wipers

### Headlight cleaner switch\*

Washer fluid can be sprayed on the headlights.



Press the switch to clean the headlights.

#### n **The headlight cleaner can be operated when**

The "ENGINE START STOP" switch is in IGNITION ON mode and the headlight switch is turned on.

#### n **Windshield washer linked operation**

When the windshield washer is operated with the "ENGINE START STOP" switch in IGNITION ON mode and the headlights on, the headlight cleaner will operate once. (→P. 197)

#### NOTICE

#### n **When the washer fluid tank is empty**

Do not press the switch continually as the washer fluid pump may overheat.

## 2-4. Using other driving systems

### Cruise control\*

Use the cruise control to maintain a set speed without depressing the accelerator pedal.



- 1 Indicator
- 2 Display
- 3 Cruise control switch

#### n Setting the vehicle speed

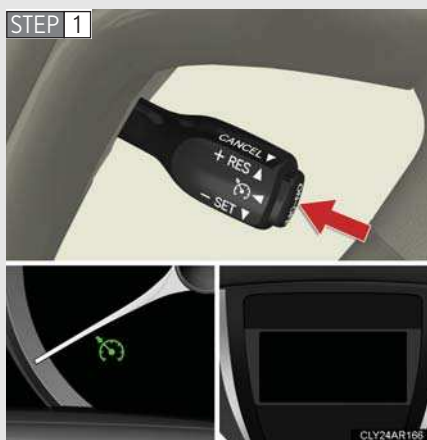

Press the “ON-OFF” button to activate the cruise control.

Press the button again to deactivate the cruise control.

STEP 2



### n Adjusting the set speed

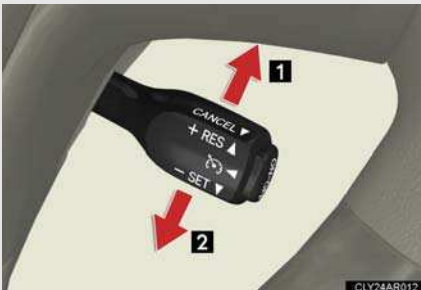

### n Canceling and resuming the constant speed control

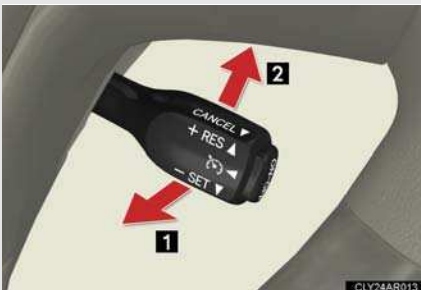

Accelerate or decelerate to the desired speed, and push the lever down to set the speed.

“SET” will be displayed.

- 1 Increases the speed
- 2 Decreases the speed

Hold the lever until the desired speed setting is obtained.

Fine adjustment of the set speed can be made by lightly pushing the lever up or down and releasing it.

- 1 Pulling the lever towards you cancels the constant speed control.

The speed setting is also canceled when the brakes are applied.

- 2 Pushing the lever up resumes the constant speed control.

### ■ **Cruise control can be set when**

- 1 The shift lever is in D or “4”, “5” or “6” range of S has been selected.
- 1 Vehicle speed is above 25 mph (40 km/h).

### ■ **Accelerating**

The vehicle can be accelerated normally. After acceleration, the set speed resumes.

### ■ **Automatic cruise control cancelation**

The cruise control will stop maintaining the vehicle speed in any of the following situations:

- 1 Actual vehicle speed falls more than 10 mph (16 km/h) below the preset vehicle speed.  
At this time, the memorized set speed is not retained.
- 1 Actual vehicle speed is below 25 mph (40km/h).
- 1 VSC is activated.

### ■ **If the cruise control indicator light flashes**

Press the “ON-OFF” button once to deactivate the system, and then press the button again to reactivate the system.

If the cruise control speed cannot be set or if the cruise control cancels immediately after being activated, there may be a malfunction in the cruise control system. Have the vehicle inspected by your Lexus dealer.

 **CAUTION****n To avoid operating the cruise control by mistake**

Switch the cruise control off using the “ON-OFF” button when not in use.

**n Situations unsuitable for cruise control**

Do not use cruise control in any of the following situations.

Doing so may result in loss of control and could cause an accident resulting in death or serious injury.

**I** In heavy traffic

**I** On roads with sharp bends

**I** On slippery roads, such as those covered with rain, ice or snow

**I** On winding roads

**I** On steep hills

Vehicle speed may exceed the set speed when driving down a steep hill.

**I** When your vehicle is towing anything

## 2-4. Using other driving systems

### Dynamic radar cruise control\*

Dynamic radar cruise control supplements conventional cruise control with a vehicle-to-vehicle distance control. In the vehicle-to-vehicle distance control mode, the vehicle automatically accelerates or decelerates in order to maintain a set following distance from vehicles ahead.

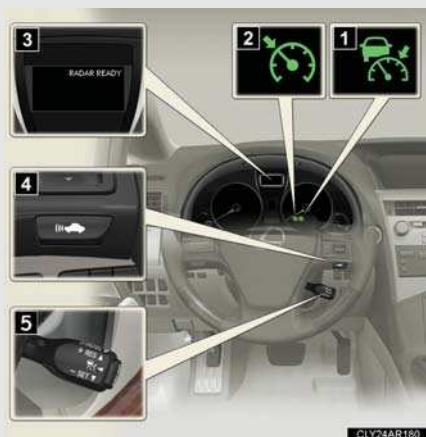

- 1 Indicator (vehicle-to-vehicle distance control mode)
- 2 Indicator (constant speed control mode)
- 3 Display
- 4 Vehicle-to-vehicle distance switch
- 5 Cruise control switch

#### n Selecting cruise mode



Selecting vehicle-to-vehicle distance control mode:

Press the “ON-OFF” button to activate the cruise control.

Press the button again to deactivate the cruise control.



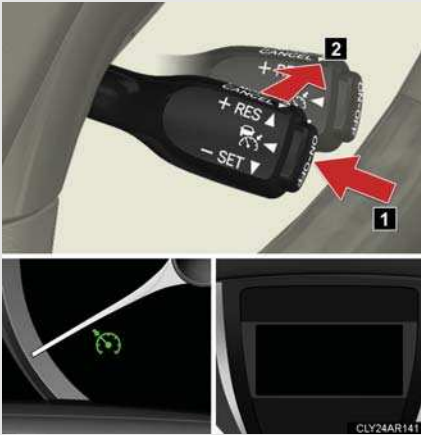

Selecting conventional constant speed control mode:

- 1 Press the “ON-OFF” button to activate the cruise control.

Press the button again to deactivate the cruise control.

- 2 Switch to constant speed control mode.

(Push and hold for approximately one second.)

Constant speed control mode indicator will come on.

Vehicle-to-vehicle distance control mode is always reset when the “ENGINE START STOP” switch is turned to IGNITION ON mode.

## n Driving in the selected cruise control mode



Accelerate or decelerate to the desired speed, and push the lever down to set the speed.

“SET” will be displayed.

**n** Adjusting the speed setting

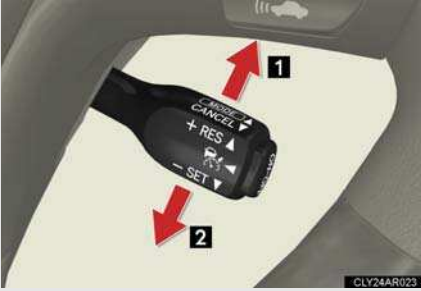

- 1** Increases the speed
- 2** Decreases the speed

Hold the lever until the desired speed setting is displayed.

Fine adjustment of the set speed can be made by lightly pushing the lever up or down and releasing it.

**n** Canceling and resuming the constant speed control

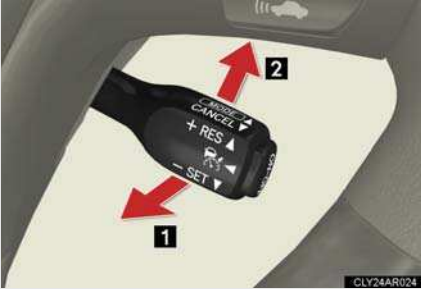

- 1** Pulling the lever toward you cancels the constant speed control.

The speed setting is also canceled when the brakes are applied.

- 2** Pushing the lever up resumes the constant speed control.

## n Changing the vehicle-to-vehicle distance

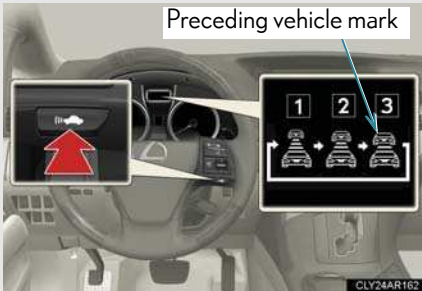

Pressing the button changes the vehicle-to-vehicle distance as follows:

- 1 Long
- 2 Medium
- 3 Short

The vehicle-to-vehicle distance is set automatically to long mode when the “ENGINE START STOP” switch is turned to IGNITION ON mode.

If a vehicle is running ahead of you, the preceding vehicle mark will be also displayed.

### Driving in vehicle-to-vehicle distance control mode

This mode employs a sensor to detect the presence of vehicles up to approximately 400 ft. (120 m) ahead and to judge the distance between your vehicle and the vehicle ahead of you.

Note that vehicle-to-vehicle distance will close in when traveling on long downhill slopes.

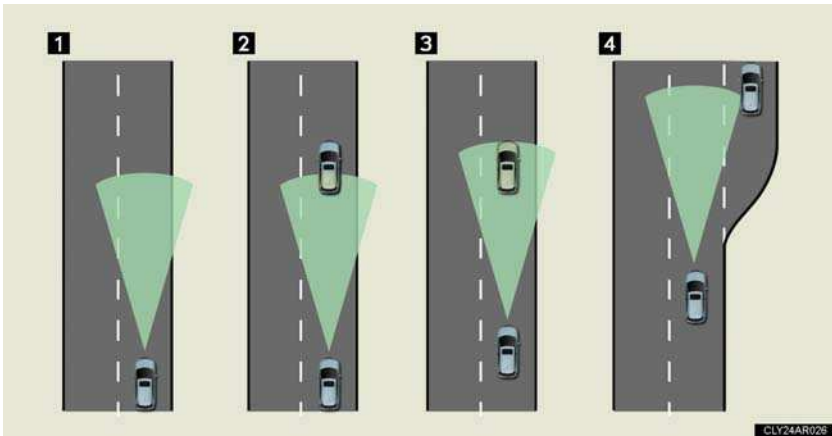

**1** Example of constant speed cruising

When there are no vehicles ahead

The vehicle travels at the speed set by the driver. The desired vehicle-to-vehicle distance can also be set by operating the vehicle-to-vehicle distance control.

**2** Example of deceleration cruising

When the vehicle ahead is driving slower than the set speed

When a vehicle is detected running ahead of you in the same lane, the system automatically decelerates your vehicle. When a greater reduction in vehicle speed is necessary, the system applies the brakes. A warning tone warns you when the system cannot decelerate sufficiently to prevent your vehicle from closing in on the vehicle ahead.

**3** Example of follow-up cruising

When following a vehicle driving slower than the set speed

The system continues follow-up cruising while adjusting for changes in the speed of the vehicle ahead in order to maintain the vehicle-to-vehicle distance set by the driver.

**4** Example of acceleration

When there no longer are vehicles driving slower than the set speed in the lane ahead

When the vehicle ahead of you executes a lane change, the system slowly accelerates until the set speed is reached. The system then returns to constant speed cruising.

### Approach warning

When your vehicle is too close to a vehicle ahead, and sufficient automatic deceleration via the cruise control is not possible, the display will flash and a buzzer will sound to alert the driver. An example of this would be if another driver cuts in front of you while you are following a vehicle. Apply the brakes to ensure an appropriate vehicle-to-vehicle distance.

#### n **Dynamic radar cruise can be set when**

##### 1 The shift lever is in D. (Recommended)

Dynamic radar cruise control can also be set when the shift lever is in the S position and range "4", "5", or "6" has been selected.

##### 1 Vehicle speed is above approximately 30 mph (50 km/h).

#### n **Switching modes**

The mode cannot be switched to constant speed control mode if vehicle-to-vehicle distance control mode has been used. The mode also cannot be switched from constant speed control to vehicle-to-vehicle distance control mode. Turn the system off by pressing the "ON-OFF" button, and turn it on again.

#### n **Accelerating**

The vehicle can accelerate normally. After acceleration, the set speed resumes.

### ■ Automatic cancelation of vehicle-to-vehicle distance control

Vehicle-to-vehicle distance control driving is automatically canceled in the following situations:

- 1 Actual vehicle speed falls below approximately 25 mph (40 km/h).
- 1 VSC is activated.
- 1 The sensor cannot operate correctly because it is covered in some way.
- 1 The windshield wipers are operating at high speed.
- 1 When snow mode is set.

If vehicle-to-vehicle distance control driving is automatically canceled for any other reason, there may be a malfunction in the system. Contact your Lexus dealer.

### ■ Automatic cancelation of constant speed control

The cruise control will stop maintaining the vehicle speed in the following situations:

- 1 Actual vehicle speed is more than 10 mph (16 km/h) below the set vehicle speed.  
At this time, the memorized set speed is not retained.
- 1 Vehicle speed falls below approximately 25 mph (40 km/h).
- 1 VSC is activated.

### ■ Vehicle-to-vehicle distance settings

Select a distance from the table below. Note that the distances shown correspond to a vehicle speed of 50 mph (80 km/h). Vehicle-to-vehicle distance increases/decreases in accordance with vehicle speed.

Distance options	Vehicle-to-vehicle distance
Long	Approximately 164 ft. (50 m)
Medium	Approximately 132 ft. (40 m)
Short	Approximately 82 ft. (25 m)

### n Radar sensor and grille cover

Always keep the sensor and grille cover clean to ensure that the vehicle-to-vehicle distance control operates properly. (Some obstructions, such as snow, ice and plastic objects, cannot be detected by the obstruction sensor.)

Dynamic radar cruise control is canceled if an obstruction is detected.



- 1 Grille cover
- 2 Radar sensor

### n Warning lights and messages for dynamic radar cruise control

Warning lights and messages are used to indicate a system malfunction or to inform the driver of the need for caution while driving. (→P. 551)

### n Approach warning

In the following instances, there is a possibility that the approach warnings will not occur:

- 1 When the speed of the vehicle ahead matches or exceeds your vehicle speed
- 1 When the vehicle ahead is traveling at an extremely slow speed
- 1 Immediately after the cruise control speed was set
- 1 At the instant the accelerator is applied

### n Certification

► For vehicles sold in U.S.A.

FCC ID: HYQDNMWR005

This device complies with Part 15 of the FCC Rules. Operation is subject to the following two conditions: (1) this device may not cause harmful interference, and (2) this device must accept any interference received, including interference that may cause undesired operation.

#### FCC WARNING

Changes or modifications not expressly approved by the party responsible for compliance could void the use's authority to operate the equipment.

Radio frequency radiation exposure Information:

This equipment complies with FCC radiation exposure limits set forth for an uncontrolled environment.

This equipment should be installed and operated with minimum distance of 20 cm between the radiator and your body.

This transmitter must not be co-located or operating in conjunction with any other antenna or transmitter.

► For vehicles sold in Canada

Operation is subject to the following two conditions: (1) this device may not cause interference, and (2) this device must accept any interference, including interference that may cause undesired operation of the device.

### CAUTION

#### n Before using dynamic radar cruise control

Do not overly rely on vehicle-to-vehicle distance control.

Be aware of the set speed. If automatic deceleration/acceleration is not appropriate, adjust the vehicle speed, as well as the distance between your vehicle and vehicles ahead by applying the brakes etc.



 **CAUTION****n Cautions regarding the driving assist systems**

Observe the following precautions.

Failure to do so may cause an accident resulting in death or serious injury.

**l** Assisting the driver to measure following distance

The dynamic radar cruise control is only intended to help the driver in determining the following distance between the driver's own vehicle and a designated vehicle traveling ahead. It is not a mechanism that allows careless or inattentive driving, and it is not a system that can assist the driver in low-visibility conditions. It is still necessary for driver to pay close attention to the vehicle's surroundings.

**l** Assisting the driver to judge proper following distance.

The dynamic radar cruise control determines whether the following distance between the driver's own vehicle and a designated vehicle traveling ahead is appropriate or not. It is not capable of making any other type of judgement. Therefore, it is absolutely necessary for the driver to remain vigilant and to determine whether or not there is a possibility of danger in any given situation.

**l** Assisting the driver to operate the vehicle

The dynamic radar cruise control has no capability to prevent or avoid a collision with a vehicle traveling ahead. Therefore, if there is ever any danger, the driver must take immediate and direct control of the vehicle and act appropriately in order to ensure the safety of all involved.

**n To avoid inadvertent dynamic radar cruise control activation**

Switch the cruise control off using the "ON-OFF" button when not in use.

### CAUTION

#### **n Situations unsuitable for dynamic radar cruise control**

Do not use dynamic radar cruise control in any of the following situations. Doing so may result in inappropriate speed control and could cause an accident resulting in death or serious injury.

- I In heavy traffic
- I On roads with sharp bends
- I On winding roads
- I On slippery roads, such as those covered with rain, ice and snow
- I On steep downhill, or where there are sudden changes between sharp up and down gradients
- I At entrances to expressways
- I When weather conditions are bad enough that they may prevent the sensors from functioning correctly (fog, snow, sandstorm, heavy rain, etc.)
- I When a buzzer is heard often
- I When your vehicle is towing anything

#### **n When the sensor may not be correctly detecting the vehicle ahead**

Apply the brakes as necessary when any of the following types of vehicles are in front of you.

As the sensor may not be able to correctly detect these types of vehicles, the approach warning (→P. 213) will not be activated, and an accident may result.

- I Vehicles that cut in suddenly
- I Vehicles traveling at low speeds
- I Vehicles that are not moving
- I Vehicles with small rear ends (trailers with no load on board etc.)
- I Motorcycles traveling in the same lane

**⚠ CAUTION****n Conditions under which the vehicle-to-vehicle distance control may not function correctly**

Apply the brakes as necessary in the following conditions as the radar sensor may not be able to correctly detect vehicles ahead, and an accident may result:

- 1 When water or snow thrown up by the surrounding vehicles hinders the functioning of the radar sensor
- 1 When your vehicle is pointing upwards (caused by a heavy load in the luggage compartment etc.)
- 1 When the road curves or when the lanes are narrow
- 1 When steering wheel operation or your position in the lane is unstable
- 1 When the vehicle ahead of you decelerates suddenly

**n To ensure the radar sensor functions correctly**

Do not do the following to the sensor or grille as doing so may cause the sensor not to function correctly and could result in an accident:

- 1 Sticking or attaching anything to them
- 1 Leaving them dirty
- 1 Disassembling or subjecting them to strong shocks
- 1 Modifying or painting them
- 1 Replacing them with non-genuine parts

**n Handling the radar sensor**

Observe the following to ensure the cruise control system can function effectively:

- 1 Keep the sensor and front grille clean at all times.  
Clean the sensor and front grille with a soft cloth so you do not mark or damage them.
- 1 Do not subject the sensor or surrounding area to a strong impact.  
If the sensor moves even slightly off position, the system may malfunction. If the sensor or surrounding area is subject to a strong impact, always have the area inspected and adjusted by your Lexus dealer.
- 1 Do not disassemble the sensor.
- 1 Do not attach accessories or stickers to the sensor, grille or surrounding area.
- 1 Do not modify or paint the sensor and grille.

## 2-4. Using other driving systems

### Intuitive parking assist\*

The distance to obstacles measured by the sensors is communicated via the multi-information display and a buzzer when parallel parking or maneuvering into a garage is conducted. Always check the surrounding area when using this system.

#### n Types of sensors



- 1 Front corner sensors
- 2 Rear corner sensors
- 3 Rear center sensors

#### n Setting the Intuitive parking assist mode



- 1 Press the menu switch.  
The multi-information display will change modes to electronic features control mode.
- 2 Press the “ENTER” switch upwards or downwards until the intuitive parking assist mark appears in the multi-information display.

\*: If equipped



Press the “ENTER” switch to change to “ON”.

The intuitive parking assist indicator will be displayed.

Each pressing of the switch turns the intuitive parking assist on and off.

When on, the buzzer sounds to inform the driver that the system is operational.

Press the menu switch to change to the normal display.

2

When driving

## Display

When the sensors detect an obstacle, the graphic is shown on the multi-information display depending on the position and distance to the obstacle.





- 1 Front corner sensor operation
- 2 Rear corner sensor operation
- 3 Rear center sensor operation



## The distance display and buzzer

When a sensor detects an obstacle, the direction of and the approximate distance to the obstacle are displayed and the buzzer sounds.





### n Front corner sensors

Detection level	Multi-information display	Approximate distance to obstacle	Buzzer
2		2.0 to 1.6 ft. (60 to 47.5 cm)	Medium
3		1.6 to 1.2 ft. (47.5 to 35 cm)	Fast
4		1.2 ft. (35 cm) or less	Continuous

### n Rear corner sensors

Detection level	Multi-information display	Approximate distance to obstacle	Buzzer
2		1.6 to 1.2 ft. (50 to 37.5 cm)	Medium
3		1.2 to 0.8 ft. (37.5 to 25 cm)	Fast
4		0.8 ft. (25 cm) or less	Continuous

## n Rear center sensors

Detection level	Multi-information display	Approximate distance to obstacle	Buzzer
1		4.9 to 2.0 ft. (150 to 60 cm)	Slow
2		2.0 to 1.5 ft. (60 to 45 cm)	Medium
3		1.5 to 1.2 ft. (45 to 35 cm)	Fast
4		1.2 ft. (35 cm) or less	Continuous

## Detection range of the sensors

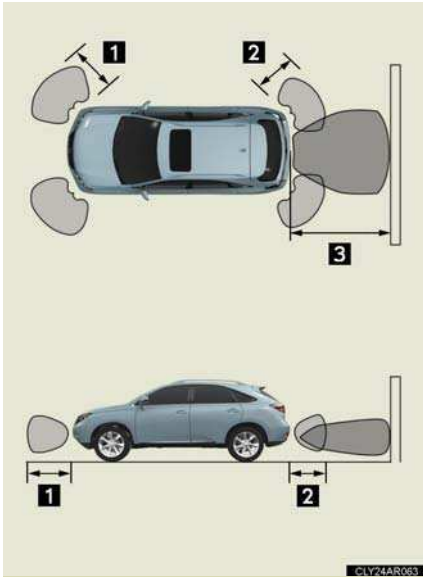

- 1 Approximately 2.0 ft. (60 cm)
- 2 Approximately 1.6 ft. (50 cm)
- 3 Approximately 4.9 ft. (150 cm)

The diagram shows the detection range of the sensors. Note that the sensors cannot detect obstacles that are extremely close to the vehicle.

The range of the sensors may change depending on the shape of the object etc.

### n The intuitive parking assist can be operated when

#### l Front corner sensors:

- The “ENGINE START STOP” switch is in IGNITION ON mode.
- The shift lever is in a position other than P.
- The vehicle speed is less than about 6 mph (10 km/h).

#### l Rear corner and center sensors:

- The “ENGINE START STOP” switch is in IGNITION ON mode.
- The shift lever is in R.



### n **Sensor detection information**

l Certain vehicle conditions and the surrounding environment may affect the ability of a sensor to correctly detect an obstacle. Particular instances where this may occur are listed below.

- There is dirt, snow or ice on a sensor.
- A sensor is frozen.
- A sensor is covered in any way.
- The vehicle is leaning considerably to one side.
- On an extremely bumpy road, on an incline, on gravel, or on grass
- The vicinity of the vehicle is noisy due to vehicle horns, motorcycle engines, air brakes of large vehicles, or other loud noises producing ultrasonic waves.
- There is another vehicle equipped with parking assist sensors in the vicinity.
- A sensor is coated with a sheet of spray or heavy rain.
- The vehicle is equipped with a fender pole or radio antenna.
- Towing eyelets are installed.
- A bumper or sensor receives a strong impact.
- The vehicle is approaching a tall or right-angled curb.
- In harsh sunlight or intense cold weather.
- A non-genuine Lexus suspension (lowered suspension, etc.) is installed.

In addition to the examples above, there are instances in which, because of their shapes, signs and other objects may be judged by a sensor to be closer than they are.

l The shape of the obstacle may prevent a sensor from detecting it. Pay particular attention to the following obstacles:

- Wires, fences, ropes, etc.
- Cotton, snow and other materials that absorb sound waves
- Sharply-angled objects
- Low obstacles
- Tall obstacles with upper sections projecting outwards in the direction of your vehicle

### n **If a warning message is displayed**

→P. 545

### n **Certification (Canada only)**

This ISM device complies with Canadian ICES-001.

### n Customization

Settings (e.g. buzzer volume) can be changed. (Customizable features →P. 621)

### CAUTION

#### n Caution when using the intuitive parking assist

Observe the following precautions.

Failing to do so may result in the vehicle being unable to be driven safely and possibly cause an accident.

! Do not use the sensor at speeds in excess of 6 mph (10 km/h).

! Do not attach any accessories within the sensor range.

### NOTICE

#### n Notes when washing the vehicle

Do not apply intensive bursts of water or steam to the sensor area.

Doing so may result in the sensor malfunctioning.

#### n Conditions possibly indicating system malfunctions

If any of the following occurs, the system may be malfunctioning due to a sensor failure etc. Have the vehicle inspected by your Lexus dealer.

! The buzzer does not sound when the intuitive parking assist mode is set.

! The sensor operation display flashes and the buzzer sounds even when no obstacle is detected.

! An area of the sensors is hit or subjected to a strong impact.

! Either bumper is hit.

! The sensor operation display remains on even though no buzzer sounds.

## 2-4. Using other driving systems

### Rear view monitor system (rear view mirror-attached type)\*

The rear view monitor system assists the driver by displaying an image of the area behind the vehicle. The image is displayed in reverse on the screen. This reversed image is a similar image to the one on the inside rear view mirror.



The rear view image is displayed when the shift lever is in the R position.

If the shift lever is shifted out of R, the screen is turned off.

### ■ The rear view monitor system can be operated when

The "ENGINE START STOP" switch is in IGNITION ON mode and the back door is fully closed.

### ■ Switching the screen on/off



When the screen is displayed, press the "AUTO" button on the inside rear view mirror to switch the screen on/off

Screen on: Green indicator comes on.

Screen off: Orange indicator comes on.

The auto anti-glare inside rear view mirror will revert to the screen on each time the "ENGINE START STOP" switch to the IGNITION ON mode.

### ■ Displayed area

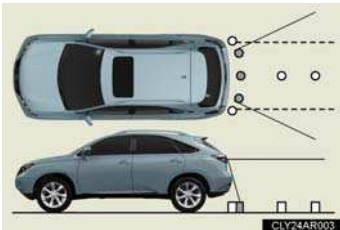

The area covered by the camera is limited. Objects that are close to either corner of the bumper or under the bumper cannot be seen on the screen.

The area displayed on the screen may vary according to vehicle orientation or road conditions.

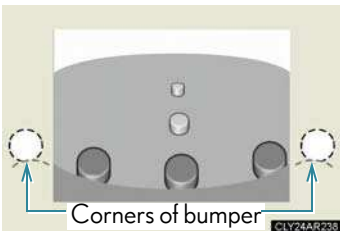

## n Rear view monitor system camera



In the following cases, it may become difficult to see the images on the screen, even when the system is functioning correctly:

- 1 The vehicle is in a dark area, such as at night.
- 1 The temperature near the lens is extremely high or low.
- 1 Water droplets are on the camera lens or humidity is high, such as when it rains.
- 1 Foreign matter, such as snow or mud, adheres to the camera lens.
- 1 The sun or headlights are shining directly into the camera lens.

## n Smear effect

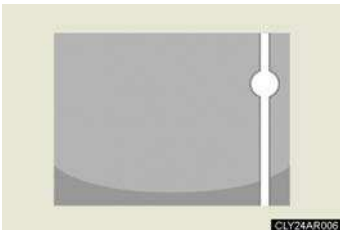

If a bright light, such as sunlight reflected off the vehicle body, is picked up by the camera, a smear effect\* characteristic to the camera may occur.

\*: Smear effect — A phenomenon that occurs when a bright light is picked up by the camera; when transmitted by the camera, the light source appears to have a vertical streak above and below it.

### CAUTION

- n** When using the rear view monitor system, observe the following precautions to avoid an accident that could result in death or serious injuries:
  - l** Never depend solely on the monitor system when reversing.
  - l** Always check visually and with the mirrors to confirm your intended path is clear.
  - l** Depicted distances between objects and flat surfaces differ from actual distances.
- n** Conditions which may affect the rear view monitor system
  - l** If the back of the vehicle has been hit, the camera's position and mounting angle may have changed. Have the vehicle inspected by your Lexus dealer.
  - l** Rapid temperature changes, such as when hot water is poured on the vehicle in cold weather, may cause the system to function abnormally.
  - l** If the camera lens is dirty, it cannot transmit a clear image. Rinse with water and wipe with a soft cloth. If extremely dirty, wash with a mild cleanser and rinse.
  - l** The displayed image may be darker and moving images may be slightly distorted when the system is cold.

### Driving assist systems

To help enhance driving safety and performance, the following systems operate automatically in response to various driving situations. Be aware, however, that these systems are supplementary and should not be relied upon too heavily when operating the vehicle.

#### **n ABS (Anti-lock Brake System)**

Helps to prevent wheel lock when the brakes are applied suddenly, or if the brakes are applied while driving on a slippery road surface

#### **n Brake assist**

Generates an increased level of braking force after the brake pedal is depressed, when the system detects a panic stop situation

#### **n VSC (Vehicle Stability Control)**

Helps the driver to control skidding when swerving suddenly or turning on slippery road surfaces

#### **n TRAC (Traction Control)**

Helps to maintain drive power and prevent the drive wheels from spinning when starting the vehicle or accelerating on slippery roads

#### **n Hill-start assist control**

→P. 238

#### **n EPS (Electric Power Steering)**

Employs an electric motor to reduce the amount of effort needed to turn the steering wheel

#### **n Active torque control 4WD system (AWD models only)**

Automatically switches from front-wheel drive to AWD (All-Wheel Drive) according to driving conditions, helping to ensure reliable handling and stability. Examples of conditions where the system will switch to AWD are when cornering, going uphill, starting off or accelerating, and when the road surface is slippery due to snow or rain etc.

### **n Enhanced VSC (Enhanced vehicle stability control)**

Provides cooperative control of the ABS, TRAC, VSC and EPS.  
Helps to maintain directional stability when swerving on slippery road surfaces by controlling steering performance.

### **n VDIM (Vehicle Dynamics Integrated Management) (if equipped)**

Provides integrated control of the ABS, brake assist, TRAC, VSC, enhanced VSC, and hill-start assist control systems.  
Helps to maintain vehicle stability when swerving on slippery road surfaces by controlling the brakes and engine output.

### **n PCS (Pre-Collision System) (if equipped)**

→P. 240

## When the VSC/TRAC systems are operating



If the vehicle is in danger of slipping or rolling backward when starting on an incline, or if any of the drive wheels spins, the slip indicator light flashes to indicate that the VSC/TRAC systems are operating.

A buzzer (intermittent) sounds to indicate that VSC is operating.



## Disabling the TRAC/VSC systems

If the vehicle gets stuck in fresh snow or mud, the TRAC/VSC systems may reduce power from the engine to the wheels. You may need to turn the system off to enable you to rock the vehicle in order to free it.

### n Turning off the TRAC system only



To turn the TRAC system off, quickly press and release the switch.

A message will be shown on the multi-information display.

Press the switch again to turn the system back on.

### n Turning off both TRAC and VSC systems



To turn the TRAC and VSC systems off, press and hold the switch for more than 3 seconds while the vehicle is stopped.

A message will be shown on the multi-information display and VSC off indicator light will come on.

Press the switch again to turn the systems back on.

### **n Sounds and vibrations caused by the ABS, brake assist, VSC and TRAC systems**

l A sound may be heard from the engine compartment when the engine is started or just after the vehicle begins to move. This sound does not indicate that a malfunction has occurred in any of these systems.

l Any of the following conditions may occur when the above systems are operating. None of these indicates that a malfunction has occurred.

- Vibrations may be felt through the vehicle body and steering.
- A motor sound may be heard after the vehicle comes to a stop.
- The brake pedal may pulsate slightly after the ABS is activated.
- The brake pedal may move down slightly after the ABS is activated.

### **n EPS operation sound**

When the steering wheel is operated, a motor sound (whirring sound) may be heard. This does not indicate a malfunction.

### **n Reactivation of the TRAC /VSC systems after turning off the engine**

Turning off the engine after turning off the TRAC/VSC systems will automatically reactivate them.

### **n Reactivation of the TRAC system linked to vehicle speed**

When only the TRAC system is turned off, the TRAC system will turn on when vehicle speed increases. However, when both TRAC and VSC systems are turned off, the systems will not turn on even when vehicle speed increases.

### **n Reduced effectiveness of the EPS system**

The effectiveness of the EPS system is reduced to prevent the system from overheating when there is frequent steering input over an extended period of time. The steering wheel may feel heavy as a result. Should this occur, refrain from excessive steering input or stop the vehicle and turn the engine off. The EPS system should return to normal within 10 minutes.

 **CAUTION****n The ABS does not operate effectively when**

- I Tires with inadequate gripping ability are used (such as excessively worn tires on a snow covered road).
- I The vehicle hydroplanes while driving at high speed on a wet or slick road.

**n Stopping distance when the ABS is operating will exceed that of normal conditions**

The ABS is not designed to shorten the vehicle's stopping distance. Always maintain a safe distance from the vehicle in front of you in the following situations:

- I When driving on dirt, gravel or snow-covered roads
- I When driving with tire chains
- I When driving over bumps in the road
- I When driving over roads with potholes or roads with uneven surfaces

**n TRAC may not operate effectively when**

Directional control and power may not be achievable while driving on slippery road surfaces, even if the TRAC system is operating.

Do not drive the vehicle in conditions where stability and power may be lost.

### CAUTION

#### **n When the VSC is activated**

The slip indicator light flashes and a warning buzzer sounds. Always drive carefully. Reckless driving may cause an accident. Exercise particular care when the indicator light flashes and a buzzer sounds.

#### **n When the TRAC/VSC systems are turned off**

Be especially careful and drive at a speed appropriate to the road conditions. As these are the systems to ensure vehicle stability and driving force, do not turn the TRAC/VSC systems off unless necessary.

#### **n Replacing tires**

Make sure that all tires are of the same size, brand, tread pattern and total load capacity. In addition, make sure that the tires are inflated to the recommended tire inflation pressure level.

The ABS and VSC systems will not function correctly if different tires are installed on the vehicle.

Contact your Lexus dealer for further information when replacing tires or wheels.

#### **n Handling of tires and suspension**

Using tires with any kind of problem or modifying the suspension will affect the driving assist systems, and may cause a system malfunction.

## 2-4. Using other driving systems

### All-wheel drive lock switch (AWD models)

All-wheel drive lock mode can be used when a large amount of drive power needs to be applied to all the wheels, such as when the vehicle gets stuck in mud and you need to free it.



Press the switch.

The torque of the engine is distributed to the rear wheels to the maximum extent possible in accordance with driving conditions.

Pressing the switch again cancels all-wheel drive lock mode and returns the active torque control 4WD system to normal mode. (→P. 231)

2

When driving

#### n All-wheel drive lock mode

- 1 All-wheel drive lock mode is canceled when the brakes are applied to ensure the ABS and VSC systems operate effectively.
- 1 All-wheel drive lock mode is canceled when the vehicle speed exceeds 25 mph (40 km/h).

## 2-4. Using other driving systems

### Hill-start assist control

Hill-start assist control helps to prevent the vehicle from rolling backwards when starting on an incline or slippery slope.



To engage hill-start assist control, further depress the brake pedal when the vehicle is stopped completely.

A buzzer will sound once to indicate the system is activated. The slip indicator will also start flashing.

#### n Hill-start assist control can be operated when

- 1 The shift lever is in a position other than P.
- 1 The parking brake is not applied.
- 1 The accelerator pedal is not depressed.

#### n Hill-start assist control

- 1 While hill-start assist control is operating, the brakes remain automatically applied after the driver releases the brake pedal. The stop lights and the high mounted stoplight turn on.
- 1 Hill-start assist control operates for about 2 seconds after the brake pedal is released.
- 1 If the slip indicator does not flash and the buzzer does not sound when the brake pedal is further depressed, slightly reduce the pressure on the brake pedal (do not allow the vehicle to roll backward) and then firmly depress it again. If the system still does not operate, check if the operating conditions explained above have been met.

**n Hill-start assist control buzzer**

- I When hill-start assist control is activated, the buzzer will sound once.
- I In the following situations, hill-start assist control will be canceled and the buzzer will sound twice.
  - No attempt is made to drive the vehicle within approximately 2 seconds of releasing the brake pedal.
  - The shift lever is moved to P.
  - The parking brake is applied.
  - The brake pedal is depressed again.
  - The brake pedal has been depressed for more than approximately 3 minutes.
- I If a buzzer other than the hill-start assist control buzzer is sounding, the hill-start assist control buzzer may not sound when the system is activated or canceled.

**n If the slip indicator comes on**

It may indicate a malfunction in the system. Contact your Lexus dealer.

 **CAUTION**

**n Hill-start assist control**

- I Do not overly rely on hill-start assist control. Hill-start assist control may not operate effectively on extremely steep inclines or roads covered in ice.
- I Unlike the parking brake, hill-start assist control is not intended to hold the vehicle stationary for an extended period of time. Do not attempt to use hill-start assist control to hold the vehicle on an incline for an extended period of time, as doing so may lead to an accident.

## 2-4. Using other driving systems

### Pre-Collision System \*

When the radar sensor detects the possibility of a frontal collision, pre-collision system such as the brake assist and seat belts are automatically engaged to lessen impact and injuries to occupants as well as vehicle damage.

#### **n Pre-collision seat belts (front seat belt only)**

If the pre-collision sensor detects that a collision is unavoidable, the pre-collision system will retract the seat belt before the collision occurs.

The same will happen if the driver makes an emergency braking or loses control of the vehicle. (→P. 78)

However, the system will not operate in the event of skidding when the VSC system is disabled.

#### **n Pre-collision brake assist**

When there is a high possibility of a frontal collision, the system applies greater braking force in relation to how strongly the brake pedal is depressed.

### Radar sensor



The radar sensor detects vehicles or other obstacles on or near the road ahead and determines whether a collision is imminent based on the position, speed, and heading of the obstacles.

\*: If equipped



**n The pre-collision system is operational when**

1 Pre-collision seat belt (type A)

- Vehicle speed is greater than about 4 mph (5 km/h).
- The speed at which your vehicle is approaching the obstacle or oncoming vehicle is greater than about 19 mph (30 km/h).
- The front occupants are wearing a seat belt.

1 Pre-collision seat belt (type B)

- Vehicle speed is greater than about 19 mph (30 km/h).
- The system detects sudden braking or skidding.
- The front occupants are wearing a seat belt.

1 Pre-collision brake assist

- Vehicle speed is greater than about 19 mph (30 km/h).
- The speed at which your vehicle is approaching the obstacle or the vehicle running ahead of you is greater than about 19 mph (30 km/h).
- The brake pedal is depressed.

**n Conditions that may trigger the system even if there is no possibility of collision**

1 When there is an object by the roadside at the entrance to a curve

1 When passing an oncoming vehicle on a curve

1 When driving over a narrow iron bridge

1 When there is a metal object on the road surface

1 When driving on an uneven road surface

1 When passing an oncoming vehicle on a left-turn

1 When your vehicle rapidly closes on the vehicle in front

1 When a grade separation/interchange, sign, billboard, or other structure appears to be directly in the vehicle's line of travel.

1 When climbing a steep hill causes an overhead billboard or other metallic structure to appear directly in the vehicle's line of travel.

1 When an extreme change in vehicle height occurs

1 When the axis of the radar is out of adjustment

1 When passing through certain toll gates

When the system is activated in the situations described above, there is also a possibility that the seat belts will retract quickly and the brakes will be applied with a force greater than normal. When the seat belt is locked in the retracted position, stop the vehicle in a safe place, release the seat belt and refasten it.

### ▮ **Obstacles not detected**

The sensor cannot detect plastic obstacles such as traffic cones. There may also be occasions when the sensor cannot detect pedestrians, animals, bicycles, motorcycles, trees, or snowdrifts.

### ▮ **When there is a malfunction in the system**

Warning lights and/or warning messages will turn on or flash. (→P. 535, 545)

### ▮ **Certification**

► For vehicles sold in U.S.A.

FCC ID: HYQDNMWR005

This device complies with Part 15 of the FCC Rules. Operation is subject to the following two conditions: (1) this device may not cause harmful interference, and (2) this device must accept any interference received, including interference that may cause undesired operation.

#### FCC WARNING

Changes or modifications not expressly approved by the party responsible for compliance could void the user's authority to operate the equipment.

Radiofrequency radiation exposure Information:

This equipment complies with FCC radiation exposure limits set forth for an uncontrolled environment.

This equipment should be installed and operated with minimum distance of 20 cm between the radiator (antenna) and your body.

This transmitter must not be co-located or operating in conjunction with any other antenna or transmitter.

► For vehicles sold in Canada

Operation is subject to the following two conditions: (1) this device may not cause interference, and (2) this device must accept any interference, including interference that may cause undesired operation of the device.

**⚠ CAUTION****n Limitations of the pre-collision system**

Do not rely on the pre-collision system. Always drive safely, taking care to observe your surroundings and checking for any obstacles or other road hazards.

Failure to do so may cause an accident resulting in death or serious injury.

**n When the sensor may not be correctly detecting the vehicle ahead**

Apply the brakes as necessary in any of the following situations.

- 1 When water or snow thrown up by the surrounding vehicles hinders the functioning of the sensor
- 1 When your vehicle is pointing upwards (caused by a heavy load in the luggage compartment etc.)
- 1 Vehicles that cut in suddenly
- 1 Vehicles with small rear ends (trailers with no load on board etc.)
- 1 Motorcycles traveling in the same lane

**n Handling the radar sensor**

Observe the following to ensure the pre-collision system can function effectively:

- 1 Keep the sensor and front grille clean at all times.  
Clean the sensor and front grille with a soft cloth so you do not mark or damage them.
- 1 Do not subject the sensor or surrounding area to a strong impact.  
If the sensor moves even slightly off position, the system may malfunction. If the sensor or surrounding area is subject to a strong impact, always have the area inspected and adjusted by your Lexus dealer.
- 1 Do not disassemble the sensor.
- 1 Do not attach accessories or stickers to the sensor, grille or surrounding area.
- 1 Do not modify or paint the sensor and grille cover.

## 2-5. Driving information

# Utility vehicle precautions

This vehicle belongs to the utility vehicle class, which has higher ground clearance and narrower tread in relation to the height of its center of gravity to make it capable of performing in a wide variety of off-road applications.

### Off-road vehicle feature

- 1 Specific design characteristics give it a higher center of gravity than ordinary passenger cars. This vehicle design feature causes this type of vehicle to be more likely to rollover. And, utility vehicles have a significantly higher rollover rate than other types of vehicles.
- 1 An advantage of the higher ground clearance is a better view of the road allowing you to anticipate problems.
- 1 It is not designed for cornering at the same speeds as ordinary passenger cars any more than low-slung sports cars designed to perform satisfactorily under off-road conditions. Therefore, sharp turns at excessive speeds may cause rollover.

 **CAUTION****n Off-road vehicle precautions**

Always observe the following precautions to minimize the risk of death or serious injury or damage to your vehicle:

- 1** In a rollover crash, an unbelted person is significantly more likely to die than a person wearing a seat belt. Therefore, the driver and all passengers should fasten their seat belts whenever the vehicle is moving.
- 1** Avoid sharp turns or abrupt maneuvers, if at all possible.  
Failure to operate this vehicle correctly may result in loss of control or vehicle rollover causing death or serious injury.
- 1** Loading cargo on the roof luggage carrier will make the center of the vehicle gravity higher. Avoid high speeds, sudden starts, sharp turns, sudden braking or abrupt maneuvers, otherwise it may result in loss of control or vehicle rollover due to failure to operate this vehicle correctly.
- 1** Always slow down in gusty crosswinds. Because of its profile and higher center of gravity, your vehicle is more sensitive to side winds than an ordinary passenger car. Slowing down will allow you to have better control.
- 1** Do not drive horizontally across steep slopes. Driving straight up or straight down is preferred. Your vehicle (or any similar off-road vehicle) can tip over sideways much more easily than forward or backward.

### Off-road driving

When driving your vehicle off-road, please observe the following precautions to ensure your driving enjoyment and to help prevent the closure of areas to off-road vehicles.

- 1 Drive your vehicle only in areas where off-road vehicles are permitted to travel.
- 1 Respect private property. Get owner's permission before entering private property.
- 1 Do not enter areas that are closed. Honor gates, barriers and signs that restrict travel.
- 1 Stay on established roads. When conditions are wet, driving techniques should be changed or travel delayed to prevent damage to roads.

---

#### **n Additional information for off-road driving**

► For owners in U.S. mainland, Hawaii and Puerto Rico:

To obtain additional information pertaining to driving your vehicle off-road, consult the following organizations.

- 1 State and Local Parks and Recreation Departments
- 1 State Motor Vehicle Bureau
- 1 Recreational Vehicle Clubs
- 1 U.S. Forest Service and Bureau of Land Management

 CAUTION**n Off-road driving precautions**

Always observe the following precautions to minimize the risk of death or serious injury or damage to your vehicle:

- 1 Drive carefully when off the road. Do not take unnecessary risks by driving in dangerous places.
- 1 Do not grip the steering wheel spokes when driving off-road. A bad bump could jerk the wheel and injure your hands. Keep both hands and especially your thumbs on the outside of the rim.
- 1 Always check your brakes for effectiveness immediately after driving in sand, mud, water or snow.
- 1 After driving through tall grass, mud, rock, sand, water, etc., check that there is no grass, bush, paper, rags, stone, sand, etc. adhering or trapped to the underbody. Clear off any such matter from the underbody. If the vehicle is used with these materials trapped or adhering to the underbody, a breakdown or fire could occur.
- 1 When driving off-road or in rugged terrain, do not drive at excessive speeds, jump, make sharp turns, strike objects, etc. This may cause loss of control or vehicle rollover causing death or serious injury. You are also risking expensive damage to your vehicle's suspension and chassis.

 NOTICE**n To prevent water damage**

Take all necessary safety measures to ensure that water damage to the engine or other components does not occur.

- 1 Water entering the engine air intake will cause severe engine damage.
- 1 Water entering the automatic transmission will cause deterioration in shift quality, locking up of your transmission accompanied by vibration, and ultimately damage.
- 1 Water can wash the grease from wheel bearings, causing rusting and premature failure, and may also enter the differentials, transmission and transfer case, reducing the gear oil's lubricating qualities.

### NOTICE

#### **n When you drive through water**

If driving through water, such as when crossing shallow streams, first check the depth of the water and the bottom of the stream for firmness. Drive slowly and avoid deep water.

#### **n Inspection after off-road driving**

- I** Sand and mud that has accumulated around brake discs may affect braking efficiency and may damage brake system components.
- I** Always perform a maintenance inspection after each day of off-road driving that has taken you through rough terrain, sand, mud, or water. For scheduled maintenance information, refer to the “Warranty and Services Guide/Owner’s Manual Supplement/Scheduled Maintenance”.



Take notice of the following information about storage precautions, cargo capacity and load:

- 1 Stow cargo and luggage in the luggage compartment whenever possible.
- 1 Be sure all items are secured in place.
- 1 Be careful to keep the vehicle level. Placing the weight as far forward as possible helps maintain vehicle balance.
- 1 For better fuel economy, do not carry unnecessary weight.

### Capacity and distribution

Cargo capacity depends on the total weight of the occupants.

(Cargo capacity) = (Total load capacity) – (Total weight of occupants)

#### Steps for Determining Correct Load Limit—

- (1) Locate the statement “The combined weight of occupants and cargo should never exceed XXX kg or XXX lbs.” on your vehicle’s placard.
- (2) Determine the combined weight of the driver and passengers that will be riding in your vehicle.
- (3) Subtract the combined weight of the driver and passengers from XXX kg or XXX lbs.
- (4) The resulting figure equals the available amount of cargo and luggage load capacity.  
For example, if the “XXX” amount equals 1400 lbs. and there will be five 150 lb passengers in your vehicle, the amount of available cargo and luggage load capacity is 650 lbs. (1400 – 750 (5 × 150) = 650 lbs.)
- (5) Determine the combined weight of luggage and cargo being loaded on the vehicle. That weight may not safely exceed the available cargo and luggage load capacity calculated in Step 4.

- (6) If your vehicle will be towing a trailer, load from your trailer will be transferred to your vehicle. Consult this manual to determine how this reduces the available cargo and luggage load capacity of your vehicle.  
(→P. 594)

**Example based on your vehicle**

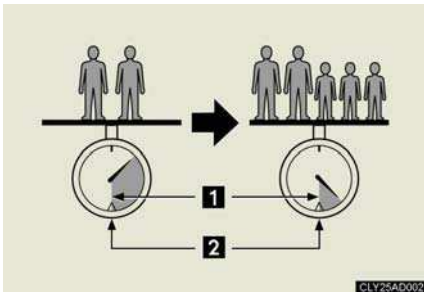

- 1 Cargo capacity
- 2 Total load capacity

When 2 people with the combined weight of 366 lb. (166 kg) are riding in your vehicle, which has a total load capacity of 885 lb. (400 kg), the available amount of cargo and luggage load capacity will be as follows:

$$885 \text{ lb.} - 366 \text{ lb.} = 519 \text{ lb.} \quad (400 \text{ kg} - 166 \text{ kg} = 234 \text{ kg})$$

In this condition, if 3 more passengers with the combined weight of 388 lb. (176 kg) get on, the available cargo and luggage load will be reduced as follows:

$$519 \text{ lb.} - 388 \text{ lb.} = 131 \text{ lb.} \quad (234 \text{ kg} - 176 \text{ kg} = 58 \text{ kg})$$

As shown in the example above, if the number of occupants increases, the cargo and luggage load will be reduced by an amount that equals the increased weight due to the additional occupants. In other words, if an increase in the number of occupants causes an excess of the total load capacity (combined weight of occupants plus cargo and luggage load), you must reduce the cargo and luggage on your vehicle.

**! CAUTION****n Things that must not be carried in the luggage compartment**

The following things may cause a fire if loaded in the luggage compartment:

- I Receptacles containing gasoline
- I Aerosol cans

**n Storage precautions**

Observe the following precautions.

Failure to do so may result in death or serious injury.

- I Stow cargo and luggage in the luggage compartment whenever possible.
- I Do not stack cargo and luggage in the luggage compartment higher than the seatbacks.  
Such items may be thrown about and possibly injure people in the vehicle in the event of sudden braking or in an accident.

- I Do not place cargo or luggage in or on the following locations as the item may get under the brake or accelerator pedal and prevent pedals from being depressed properly, block the driver's vision, or hit the driver or passengers, causing an accident:

- At the feet of the driver
- On the front passenger or rear seats (when stacking items)
- On the luggage cover
- On the instrument panel
- On the dashboard

- I Secure all items in the occupant compartment, as they may shift and injure someone in the event of sudden braking, sudden swerving or an accident.
- I Never allow anyone to ride in the luggage compartment. It is not designed for passengers. They should ride in their seats with their seat belts properly fastened. Otherwise, they are much more likely to suffer death or serious bodily injury, in the event of sudden braking, sudden swerving or an accident.

**n Capacity and distribution**

- I Do not exceed the maximum axle weight rating or the total vehicle weight rating.
- I Even if the total load of occupant's weight and the cargo load is less than the total load capacity, do not apply the load unevenly. Improper loading may cause deterioration of steering or braking control which may cause death or serious injury.

### CAUTION

#### **n** Roof luggage carrier precautions

To use the roof rails as a roof luggage carrier, you must fit the roof rails with two or more genuine Lexus cross rails or their equivalent.

When you load cargo on the roof luggage carrier, observe the following:

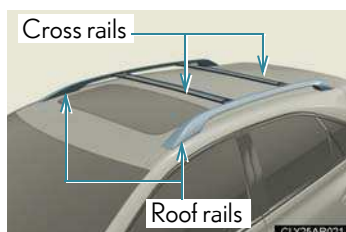

- I** Place the cargo so that its weight is distributed evenly between the front and rear axles.
- I** If loading long or wide cargo, never exceed the vehicle's overall length or width. (→P. 594)

- I** Before driving, make sure the cargo is securely fastened on the roof luggage carrier.
- I** Loading cargo on the roof luggage carrier will make the center of gravity of the vehicle higher. Avoid high speeds, sudden starts, sharp turns, sudden braking or abrupt maneuvers, otherwise the result may be a loss of control or vehicle roll-over due to failure to operate this vehicle correctly and result in death or serious injury.
- I** If driving for a long distances, on rough roads, or at high speeds, stop the vehicle now and then during the trip to make sure the cargo remains in its place.
- I** Do not exceed 165 lb. (75 kg) cargo weight on the roof luggage carrier.
- I** To reduce wind noise when there is no luggage loaded on the roof luggage carrier, move the front cross rail to the front-most position and the rear cross rail to the rearmost position.

### NOTICE

#### **n** When loading cargo

Be careful not to scratch the surface of the moon roof.

## 2-5. Driving information

# Vehicle load limits

Vehicle load limits include total load capacity, seating capacity, towing capacity and cargo capacity.

**n Total load capacity: 885 lb. (400 kg)**

Total load capacity means the combined weight of occupants, cargo and luggage.

**n Seating capacity: 5 occupants (Front 2, Rear 3)**

Seating capacity means the maximum number of occupants whose estimated average weight is 150 lb. (68 kg) per person.

**n Towing capacity**

**Without a towing package: 2000 lb. (907 kg)**

**With a towing package: 3500 lb. (1588 kg)**

Towing capacity means the maximum gross trailer weight (trailer weight plus its cargo weight) that your vehicle is able to tow.

**n Cargo capacity**

Cargo capacity may increase or decrease depending on the weight and the number of occupants.

---

**n Total load capacity and seating capacity**

These details are also described on the tire and loading information label. (→P. 487)

**! CAUTION**

**n Overloading the vehicle**

Do not overload the vehicle.

It may not only cause damage to the tires, but also degrade steering and braking ability, resulting in an accident.

# Winter driving tips

Carry out the necessary preparations and inspections before driving the vehicle in winter. Always drive the vehicle in a manner appropriate to the prevailing weather conditions.

### n Pre-winter preparations

- 1 Use fluids that are appropriate to the prevailing outside temperatures.
  - Engine oil
  - Engine coolant
  - Washer fluid
- 1 Have a service technician inspect the level and specific gravity of battery electrolyte.
- 1 Have the vehicle fitted with four snow tires or purchase a set of tire chains for the front tires.

Ensure that all tires are the same size and brand, and that chains match the size of the tires.

### n Before driving the vehicle

Perform the following according to the driving conditions:

- 1 Do not try to forcibly open a window or move a wiper that is frozen. Pour warm water over the frozen area to melt the ice. Wipe away the water immediately to prevent it from freezing.
- 1 To ensure proper operation of the climate control system fan, remove any snow that has accumulated on the air inlet vents in front of the windshield.
- 1 Remove any ice that has accumulated on the vehicle chassis.
- 1 Periodically check for and remove any excess ice or snow that may have accumulated in the wheel well or on the brakes.

**n When driving the vehicle**

Accelerate the vehicle slowly and drive at a reduced speed suitable to the road conditions.

**n When parking the vehicle**

Park the vehicle and move the shift lever to P without setting the parking brake. The parking brake may freeze up, preventing it from being released. If necessary, block the wheels to prevent inadvertent sliding or creeping.

2

When driving

**Selecting tire chains**

Use the correct tire chain size when mounting the tire chains. Chain size is regulated for each tire size.

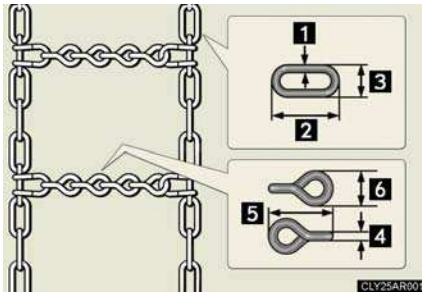

Side chain:

- 1 0.12 in. (3 mm) in diameter
- 2 0.98 in. (25 mm) in length
- 3 0.43 in. (10.8 mm) in width

Cross chain:

- 4 0.15 in. (3.9 mm) in diameter
- 5 1.00 in. (25.3 mm) in length
- 6 0.54 in. (13.8 mm) in width

**Regulations on the use of tire chains**

Regulations regarding the use of tire chains vary depending on location and type of road. Always check local regulations before installing chains.

### **n Tire chain installation**

Observe the following precautions when installing and removing chains:

- 1 Install and remove tire chains in a safe location.
- 1 Install tire chains on the front tires only. Do not install tire chains on the rear tires.
- 1 Install the tire chains on front tires as tightly as possible. Retighten chains after driving 1/4 — 1/2 mile (0.5 — 1.0 km).
- 1 Install tire chains following the instructions provided with the tire chains.

### **! CAUTION**

#### **n Driving with snow tires**

Observe the following precautions to reduce the risk of accidents.

Failure to do so may result in a loss of vehicle control and cause death or serious injury.

- 1 Use tires of the size specified for your vehicle.
- 1 Maintain the recommended level of air pressure.
- 1 Do not drive in excess of 75 mph (120 km/h), regardless of the type of snow tires being used.
- 1 Use snow tires on all, not just some wheels.

#### **n Driving with tire chains**

Observe the following precautions to reduce the risk of accidents.

Failure to do so may result in the vehicle being unable to be driven safely, and may cause death or serious injury.

- 1 Do not drive in excess of the speed limit specified for the tire chains being used, or 30 mph (50 km/h), whichever is lower.
- 1 Avoid driving on bumpy road surfaces or over potholes.
- 1 Avoid sudden turns and braking, as use of chains may adversely affect vehicle handling.
- 1 Slow down sufficiently before entering a curve to ensure that vehicle control is maintained.



 NOTICE**n Repairing or replacing snow tires**

Request repairs or replacement of snow tires from Lexus dealers or legitimate tire retailers.

This is because the removal and attachment of snow tires affects the operation of the tire pressure warning valves and transmitters.

**n Fitting tire chains**

The tire pressure warning valves and transmitters may not function correctly when tire chains are fitted.

### Trailer towing

Your vehicle is designed primarily as a passenger-and-load carrying vehicle. Towing a trailer will have an adverse effect on handling, performance, braking, durability, and fuel consumption. For your safety and the safety of others, do not overload the vehicle or trailer.

To tow a trailer safely, use extreme care and drive the vehicle in accordance with the trailer's characteristics and operating conditions.

The vehicle stability and braking performance are affected by trailer stability, brake setting and performance, and the hitch.

Lexus warranties do not apply to damage or malfunction caused by towing a trailer for commercial purposes.

Contact your Lexus dealer for further information about additional requirements such as a towing kit etc.

## Weight limits

Confirm that the gross trailer weight, gross vehicle weight, gross axle weight and trailer tongue load are all within the limits.

- 1 The gross trailer weight must never exceed the following:

Without towing package: 2000 lb. (907 kg)

With towing package: 3500 lb. (1588 kg)

- 1 The gross combined weight must never exceed the following:

### Without towing package

2WD: 7560 lb. (3429 kg)

AWD: 7650 lb. (3470 kg)

### With towing package

2WD: 9060 lb. (4109 kg)

AWD: 9150 lb. (4150 kg)



- 1 The gross vehicle weight must never exceed the GVWR indicated the Certification Label.
- 1 The gross axle weight on each axle must never exceed the GAWR indicated the Certification Label.

## Towing related term

Towing related term	Meaning
GVWR (Gross Vehicle Weight Rating)	The maximum allowable gross vehicle weight. The gross vehicle weight is the total weight of the vehicle. When towing a trailer, it is the sum of the vehicle weight (including the occupants, cargo and any optional equipment installed on the vehicle) and the tongue load.
GAWR (Gross Axle Weight Rating)	The maximum allowable gross axle weight. The gross axle weight is the load placed on each axle (front and rear).
GCWR (Gross Combination Weight Rating)	The maximum allowable gross combination weight. The gross combination weight is the sum of the total vehicle weight (including the occupants, cargo and any optional equipment installed on the vehicle) and the weight of the trailer being towed (including the cargo in the trailer).
Gross trailer weight	The sum of the trailer weight and the weight of the cargo in the trailer
Towing capacity	The maximum allowable gross trailer weight. Towing capacity is calculated considering the base vehicle with necessary vehicle equipment and occupants. Additional optional equipment, passengers and cargo in the vehicle will reduce the towing capacity, gross trailer weight include the trailer, cargo and necessary equipment for towing.
Tongue load	The load placed on the trailer hitch ball

## Trailer tongue load

- 1 A recommended tongue load varies in accordance with the types of trailers or towing as described below.
- 1 In order to ensure the recommended values shown below, the trailer must be loaded by referring to the following instructions. The trailer cargo load should be distributed so that the tongue load is 9 to 11% of the gross trailer weight, not exceeding the following:

Without towing package: 200 lb. (90 kg)

With towing package: 350 lb. (158 kg)

(Tongue load / Gross trailer weight x 100 = 9 to 11%)

If the gross trailer weight is over 2000 lbs. (900 kg), it is necessary to use a sway control device with sufficient capacity.

The gross trailer weight and tongue load can be measured with platform scales found at highway weighing station, building supply company, trucking company, junk yard, etc.

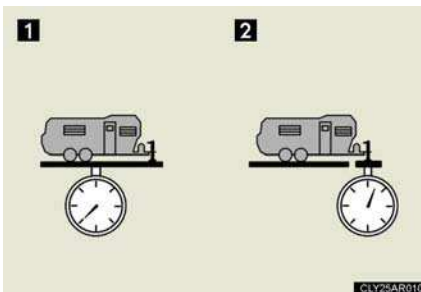

1 Gross trailer weight

2 Tongue load

## Hitch and tow hitch receiver

### n Hitch

Trailer hitch assemblies have different weight capacities established by the hitch manufacturer. Even though the vehicle may be rated for towing a higher weight, the operator must never exceed the maximum weight rating specified for the trailer hitch.

**n Tow hitch receiver (if equipped)**



A tow hitch receiver installed under the rear bumper is rated for weight that does not exceed the vehicle's total towing weight.

### Selecting trailer ball

Use the correct trailer ball for your application.

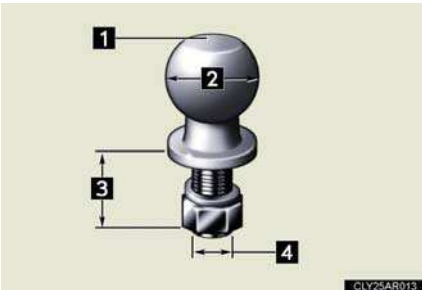

**1 Trailer ball load rating**

Matches or exceeds the gross trailer weight rating of the trailer.

**2 Ball diameter**

Matches the size of the trailer coupler. Most couplers are stamped with the required trailer ball size.

**3 Shank length**

Protrudes beyond the bottom of the lock washer and nut at least 2 threads.

**4 Shank diameter**

Matches the ball mount hole diameter size.

## Connecting trailer lights

Without towing package: Please consult your dealer when installing trailer lights, as incorrect installation may cause damage to the vehicle's lights. Please take care to comply with your state's laws when installing trailer lights.

With towing package: Use the 4 pin connector located under the rear bumper.

2

When driving

### n Auto current cut-off function (vehicles with towing package)

In case of over current, the auto cut-off function stops the power flowing to the trailer lights to prevent damage to the vehicle's electrical system.

This function is activated when the rated current of any of the following trailer light circuit components is exceeded:

- 1 Tail lights: maximum 7.8 A
- 1 Stop/turn signal light (right): maximum 4.5 A
- 1 Stop/turn signal light (left): maximum 4.5 A

### n When the auto current cut function is activated

If a trailer light does not come on due to the activation of the auto current cut function, the light system will need to be reset.

Follow the reset procedure shown below.

- 1 If a tail light does not come on, turn off the headlight switch.
- 1 If the right-side stop/turn signal light does not come on, put the turn signal in the off position or remove foot from the brake pedal.
- 1 If the left-side stop/turn signal light does not come on, put the turn signal in the off position or remove foot from the brake pedal.

If the emergency flashers do not operate, press the emergency flasher switch to turn them off.

After the light system is reset, operate the light switches again to see if the lights operate normally.

If the lights do not operate normally, have the vehicle inspected by your Lexus dealer.

### Trailer towing tips

Your vehicle will handle differently when towing a trailer. In order to avoid accident, death or serious injury, keep the following in mind when towing:

- 1 Before starting out, check the trailer lights and the vehicle-trailer connections. Recheck after driving a short distance.
- 1 Practice turning, stopping and reversing with the trailer attached in an area away from traffic until you become accustomed to the feel of the vehicle.
- 1 Reversing with a trailer attached is difficult and requires practice. Grip the bottom of the steering wheel and move your hand to the left to move the trailer to the left. Move your hand to the right to move the trailer to right. (This is generally opposite to reversing without a trailer attached.) Avoid sharp or prolonged turning. Have someone guide you when reversing to reduce the risk of an accident.
- 1 As stopping distance is increased when towing a trailer, vehicle-to-vehicle distance should be increased. For each 10 mph (16 km/h) of speed, allow at least one vehicle and trailer length.
- 1 Avoid sudden braking as you may skid, resulting in jackknifing and loss of control. This is especially true on wet or slippery surfaces.
- 1 Avoid jerky starts or sudden acceleration.
- 1 Avoid jerky steering and sharp turns, and slow down before making turns.
- 1 Note that when making a turn, the trailer wheels will be closer than the vehicle wheels to the inside of the turn. Compensate by making a larger than normal turning radius.



- 1 Crosswinds and rough roads will adversely affect handling of your vehicle and trailer, causing sway. Periodically check the rear to prepare for being passed by large trucks or buses, which may cause your vehicle and trailer to sway. If swaying occurs, firmly grip the steering wheel, reduce speed immediately but gradually, and steer straight ahead. Never increase speed. If you make no extreme correction with the steering or brakes, your vehicle and trailer will stabilize.
- 1 Take care when passing other vehicles. Passing requires considerable distance. After passing a vehicle, do not forget the length of your trailer, and be sure you have plenty of room before changing lanes.
- 1 In order to maintain engine braking efficiency when driving on a long steep downgrade, do not use overdrive. Transmission shift range position must be in 4 in S mode.
- 1 Due to the added load of the trailer, your vehicle's engine may overheat on hot days (at temperatures over 85°F [30°C]) when driving up a long or steep grade. If the engine coolant temperature gauge indicates overheating, immediately turn off the air conditioning (if in use), pull your vehicle off the road and stop in a safe spot. (→P. 587)
- 1 Always place wheel blocks under both the vehicle and the trailer wheels when parking. Apply the parking brake firmly, and put the transmission in P. Avoid parking on a slope, but if unavoidable, do so only after performing the following:
  - STEP 1** Apply the brakes and keep them applied.
  - STEP 2** Have someone place wheel blocks under both the vehicle and trailer wheels.
  - STEP 3** When the wheel blocks are in place, release the brakes slowly until the blocks absorb the load.
  - STEP 4** Apply the parking brake firmly.
  - STEP 5** Shift into P and turn off the engine.

1 When restarting after parking on a slope:

**STEP 1** With the transmission in the P position, start the engine. Be sure to keep the brake pedal depressed.

**STEP 2** Shift into 3, 2, 1, or the R position (if reversing).

**STEP 3** Release the parking brake and brake pedal, and slowly pull or back away from the wheel blocks. Stop and apply the brakes.

**STEP 4** Have someone retrieve the blocks.

---

### n **Before towing**

Check that the following conditions are met:

- 1 The vehicle's tires are properly inflated. (→P. 487)
- 1 Trailer tires are inflated according to the trailer manufacturer's recommendation.
- 1 All trailer lights work.
- 1 All lights work each time you connect them.
- 1 The trailer ball is set up at the proper height for the coupler on the trailer.
- 1 The vehicle remains level when a loaded or unloaded trailer is hitched. Do not drive if the vehicle is not level, and check for improper tongue load, overloading, worn suspension, or other possible causes.
- 1 The trailer cargo is securely loaded.
- 1 The rear view mirrors conform to all applicable federal, state/provincial or local regulations. If they do not, install rear view mirrors appropriate for towing purposes.

### n **Break-in schedule**

If your vehicle is new or equipped with any new power train components (such as an engine, transmission, differential and wheel bearing), Lexus recommends that you do not tow a trailer until it has been driven for over 500 miles (800 km). However, avoid full throttle acceleration.

### n **Maintenance**

- 1 If you tow a trailer, your vehicle will require more frequent maintenance due to the additional load. (See "Warranty and Services Guide", "Owner's Manual Supplement" or "Scheduled Maintenance".)
- 1 Retighten the fixing bolts of the towing ball and bracket after approximately 600 miles (1000 km) of trailer towing.

 **CAUTION****n Trailer towing precautions**

- I** Follow all the instructions described in this section. Failure to do so could cause an accident resulting in death or serious injury.
- I** Exceeding the towing capacity, GVWR or GAWR can cause an accident resulting in death or serious personal injuries.

**n To avoid accident or injury**

- I** Do not exceed the trailer hitch assembly weight, gross vehicle weight, gross axle weight and trailer tongue load capacities.
- I** Never load more weight in the back than in the front of the trailer. About 60% of the load should be in the front half of the trailer, and the remaining 40% in the rear.
- I** Do not use cruise control when you are towing.
- I** The tow hitch receiver installed on your vehicle must never be used on another vehicle.
- I** Do not exceed 45 mph (72 km/h) or the posted towing speed limit, whichever is lower. As instability (swaying) of the towing vehicle-trailer combination increases as speed increases, exceeding 45 mph (72 km/h) may cause loss of control.
- I** Slow down and downshift before descending steep or long downhill grades. Do not make sudden downshifts.
- I** Avoid holding the brake pedal down too long or applying the brakes too frequently. This could cause the brakes to overheat and result in reduced braking efficiency.
- I** Do not tow the vehicle with the compact spare tire installed.

### CAUTION

#### **n Hitches**

- I** If you wish to install a trailer hitch, contact your Lexus dealer.
- I** Use only a hitch that conforms to the gross trailer weight requirement.
- I** Follow the directions supplied by the hitch manufacturer.
- I** Lubricate the hitch ball with a light coat of grease.
- I** Remove the trailer hitch whenever you are not towing a trailer. After removing the hitch, seal any mounting hole in the vehicle body to prevent entry of any substances into the vehicle.

#### **n When towing a trailer**

- I** If the gross trailer weight exceeds 1000 lb. (450 kg), trailer brakes are required. Lexus recommends trailers with brakes that conform to all applicable federal and state/provincial regulations.
- I** Never tap into your vehicle's hydraulic system, as this will lower the vehicle's braking effectiveness.
- I** Never tow a trailer without using a safety chain securely attached to both the trailer and the vehicle. If damage occurs to the coupling unit or hitch ball, there is danger of the trailer wandering into another lane.

 NOTICE**n When installing a trailer hitch**

- l** Use only the position recommended by your Lexus dealer. Do not install the trailer hitch on the bumper; this may cause body damage.
- l** Do not use axle-mounted hitches, as they can cause damage to the axle housing, wheel bearings, wheels or tires.

**n Safety chain**

A safety chain must always be used between the towing vehicle and the trailer. Leave sufficient slack in the chain for turns. The chain should cross under the trailer tongue to prevent the tongue from dropping to the ground in the case that it becomes damaged or separated. For the correct safety chain installation procedure, ask your Lexus dealer.

**n Do not directly splice trailer lights**

Directly splicing trailer lights may damage your vehicle's electrical system and cause a malfunction.

## 2-5. Driving information

# Dinghy towing

Your vehicle is not designed to be dinghy towed (with 4 wheels on the ground) behind a motor home.

### NOTICE

#### n To avoid serious damage to your vehicle



Do not tow your vehicle with four wheels on the ground.

#### n To prevent causing serious damage to the transmission and Active Torque Control 4WD system (AWD models)



2WD models: Never tow this vehicle from the rear with the front wheels on the ground. This may cause serious damage to the transmission.

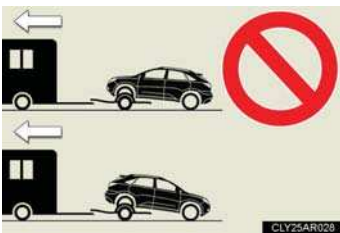

AWD models: Never tow this vehicle with any of the wheels on the ground. This may cause serious damage to the transmission and Active Torque Control 4WD system.



### 3-1. Using the air conditioning system and defogger

## Automatic air conditioning system

Air outlets and fan speed are automatically adjusted according to the temperature setting.

▶ Vehicles with a navigation system

Owners of models equipped with a navigation system should refer to the “Navigation System Owner’s Manual”.

▶ Vehicles without a navigation system

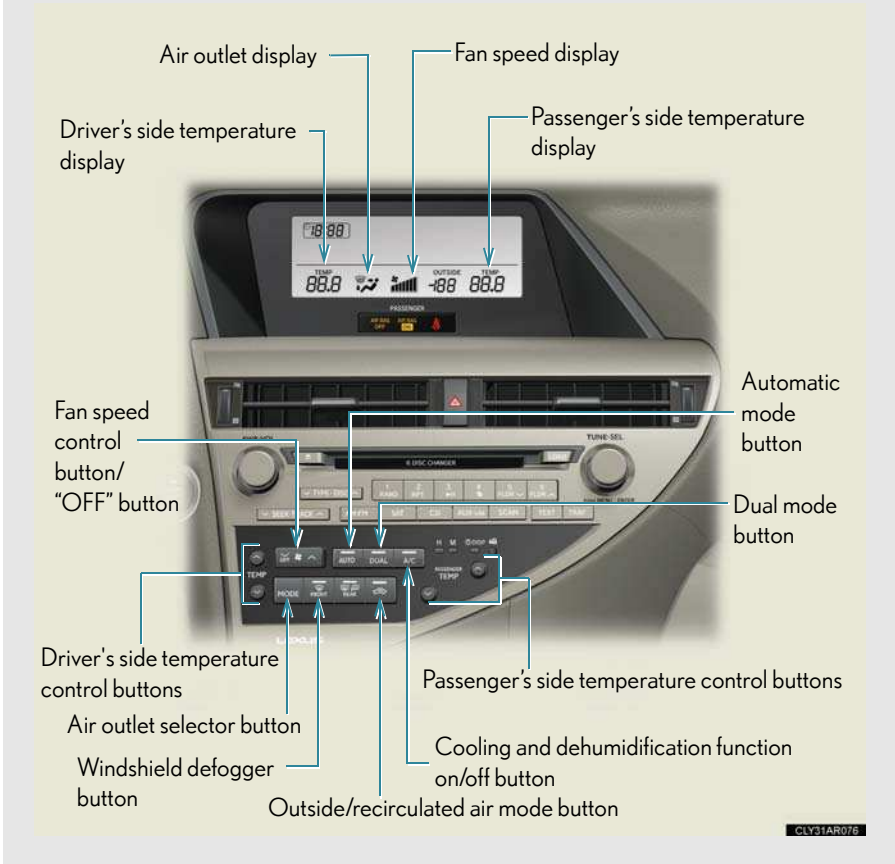





## Using automatic air conditioning system

**STEP 1** Press .

The air conditioning system begins to operate. Air outlets and fan speed are automatically adjusted according to the temperature setting.

**STEP 2** Press “^” on  to increase the temperature and “v” to decrease the temperature.

When  is pressed (the indicator on  is on) or the passenger's side temperature control button is pressed, the temperature for the driver and passenger seats can be adjusted separately.



## Adjusting the settings manually

### n Basic setting

**STEP 1** To turn on the air conditioning system and adjust the fan speed, press “^” on  to increase the fan speed and “OFF v” to decrease the fan speed.

To turn the fan off, press and hold “OFF v” on .

**STEP 2** To adjust the temperature setting, press “^” on  to increase the temperature and “v” to decrease the temperature.

When  is pressed (the indicator on  is on) or the passenger's side temperature control button is pressed, the temperature for the driver and passenger seats can be adjusted separately.

**STEP 3** To change the air outlets, press .

The air outlets used are switched each time the button is pressed. The air flow shown on the display indicates the following:

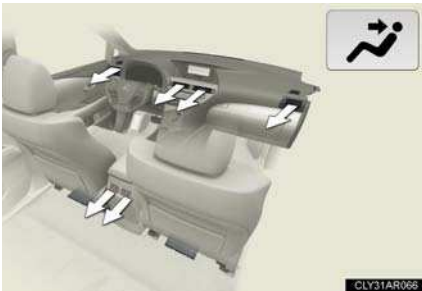

Air flows to the upper body.

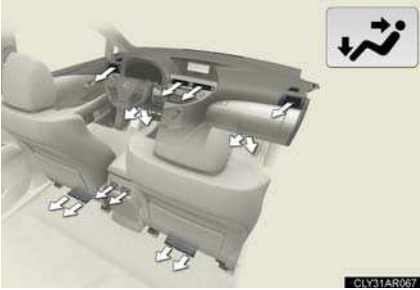

Air flows to the upper body and feet.

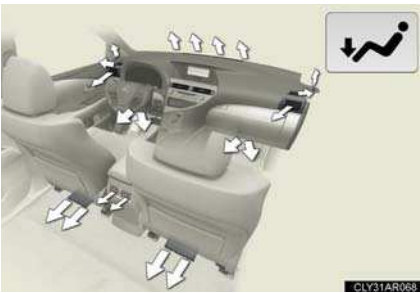

Air flows to the feet.

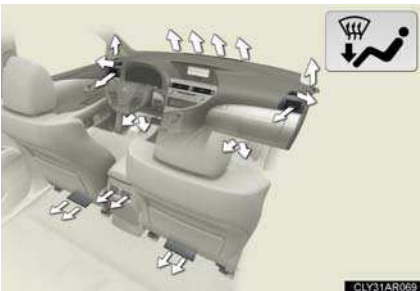

Air flows to the feet and the windshield defogger operates.

## n Switching between outside air and recirculated air modes

Press .

The mode switches between outside air mode (the indicator is off) and recirculated air mode (the indicator is on) each time the button is pressed.

## Defogging the windshield



### Defogging

The air conditioning system operates automatically.

Recirculated air mode will automatically switch to outside air mode. It is not possible to return to recirculated air mode when the switch is on.

## Adjusting the position of and opening and closing the air outlets

### ► Front center outlets

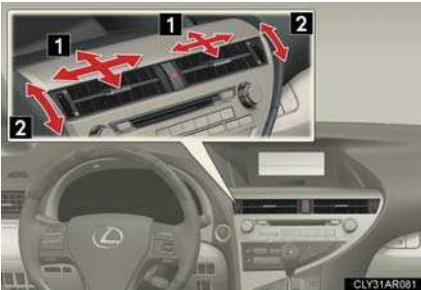

- 1 Direct air flow to the left or right, up or down.
- 2 Turn the knob to open or close the vent.

### ► Front side outlets

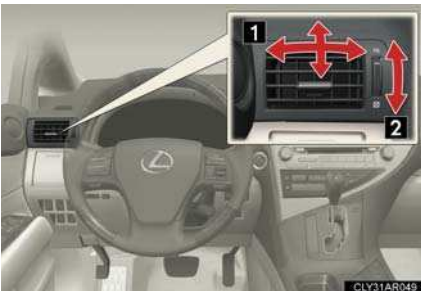

- 1 Direct air flow to the left or right, up or down.
- 2 Turn the knob to open or close the vent.

### ► Rear outlets

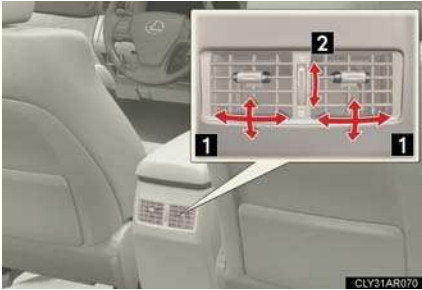

- 1 Direct air flow to the left or right, up or down.
- 2 Turn the knob to open or close the vent.

#### n Air conditioning system settings

When the “ENGINE START STOP” switch is turned on, the air conditioning system settings will be set to those that were in use the last time the “ENGINE START STOP” switch was turned off.

Air conditioning system settings are memorized individually on each electronic key, so the settings reproduced will be specific to the key that is used.

#### n Using automatic mode

Fan speed is adjusted automatically according to the temperature setting and ambient conditions. As a result, the following may occur:

Immediately after the button is pressed, the fan may stop for a while until warm or cool air is ready to flow.

#### n Using the system in recirculated air mode

The windows will fog up more easily if recirculated air mode is used for an extended period.

#### n Switching between outside air and recirculated air modes

Recirculated air mode or outside air mode may be automatically switched to in accordance with the temperature setting and the inside temperature.

#### n Window defogger feature

Recirculated air mode may automatically switch to outside air mode in situations where the windows need to be defogged.

### 3-1. Using the air conditioning system and defogger

#### n When outside air temperature is below 32°F (0°C)

The cooling and dehumidification function may not operate even when  is pressed.

#### n When the indicator light on flashes

Press  to turn off the cooling and dehumidification function and turn it on again. There may be a problem in the air conditioning system if the indicator light continues to flash. Turn the air conditioning system off and have it inspected by your Lexus dealer.

#### n Air conditioning odors

l During use, various odors from inside and outside the vehicle may enter into and accumulate in the air conditioning system. This may then cause odor to be emitted from the vents.

l To reduce potential odors from occurring:

- It is recommended that the air conditioning system be set to outside air mode prior to turning the vehicle off.
- The start timing of the blower may be delayed for a short period of time immediately after the air conditioning system is started in automatic mode.

#### CAUTION

#### n To prevent the windshield from fogging up

Do not use  during cool air operation in extremely humid weather. The difference between the temperature of the outside air and that of the windshield can cause the outer surface of the windshield to fog up, blocking your vision.

#### NOTICE

#### n To prevent battery discharge

Do not leave the air conditioning system on longer than necessary when the engine is stopped.

## 3-1. Using the air conditioning system and defogger

### Rear window defogger switch

Defoggers are used to defog the rear window, and to remove raindrops, dew and frost from the outside rear view mirrors.

▶ Without navigation system

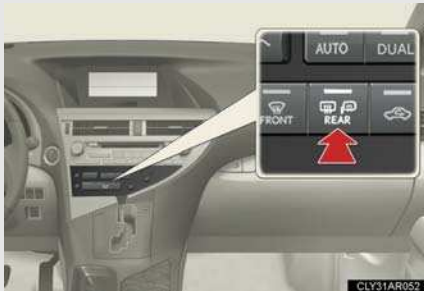

Turns the rear window and outside rear view mirror defoggers on/off

The defoggers will automatically turn off after 15 to 60 minutes. The operation time changes according to the ambient temperature and vehicle speed.

▶ With navigation system

Refer to “Navigation System Owner’s Manual”.

n **The defoggers can be operated when**

The “ENGINE START STOP” switch is in IGNITION ON mode.

n **The outside rear view mirror defoggers**

Turning the rear window defogger on will turn the outside rear view mirror defoggers on.

**! CAUTION**

n **When the outside rear view mirror defoggers are on**

Do not touch the outside surface of the rear view mirrors, as they can become very hot and burn you.

### 3-1. Using the air conditioning system and defogger

## Windshield wiper de-icer\*

This feature is used to prevent ice from building up on the windshield and wiper blades.

- ▶ Without navigation system



Turns the windshield wiper de-icer on/off

The windshield wiper de-icer will automatically turn off after approximately 15 minutes.

- ▶ With navigation system

Refer to “Navigation System Owner’s Manual”.

- 
- The windshield wiper de-icer can be operated when  
The “ENGINE START STOP” switch is in IGNITION ON mode.

### **!** CAUTION

- When the windshield wiper de-icer is on  
Do not touch the lower part of the windshield or the side of the front pillars, as the surfaces can become very hot and burn you.

\*: If equipped



## 3-2. Using the audio system

### Audio system

▶ Vehicles with a navigation system

Owners of models equipped with a navigation system should refer to the “Navigation System Owner’s Manual”.

▶ Vehicles without a navigation system

CD player with a changer and AM/FM radio

▶ Type A



### ▶ Type B



CLY02AR003

## ► Type C



Title	Page
Using the radio	P. 287
Using the CD player	P. 297
Playing MP3 and WMA discs	P. 307
Operating an iPod	P. 317
Operating a USB memory	P. 325
Optimal use of the audio system	P. 334
Using the AUX port	P. 337
Using the steering wheel audio switches	P. 339

### n Using mobile phones

Interference may be heard through the audio system's speakers if a mobile phone is being used inside or close to the vehicle while the audio system is operating.

### CAUTION

#### n Certification

##### I Part 15 of the FCC Rules

FCC Warning:

Any unauthorized changes or modifications to this equipment will void the user's authority to operate this device.

##### I Laser products

- Do not take this unit apart or attempt to make any changes by yourself.

This is an intricate unit that uses a laser pickup to retrieve information from the surface of compact discs. The laser is carefully shielded so that its rays remain inside the cabinet. Therefore, never try to disassemble the player or alter any of its parts since you may be exposed to laser rays and dangerous voltages.

- This product utilizes a laser.

Use of controls or adjustments or performance of procedures other than those specified herein may result in hazardous radiation exposure.

### NOTICE

#### n To prevent battery discharge

Do not leave the audio system on longer than necessary with the engine off.

#### n To avoid damaging the audio system

Take care not to spill drinks or other fluids over the audio system.

## 3-2. Using the audio system

### Using the radio

#### ▶ Type A

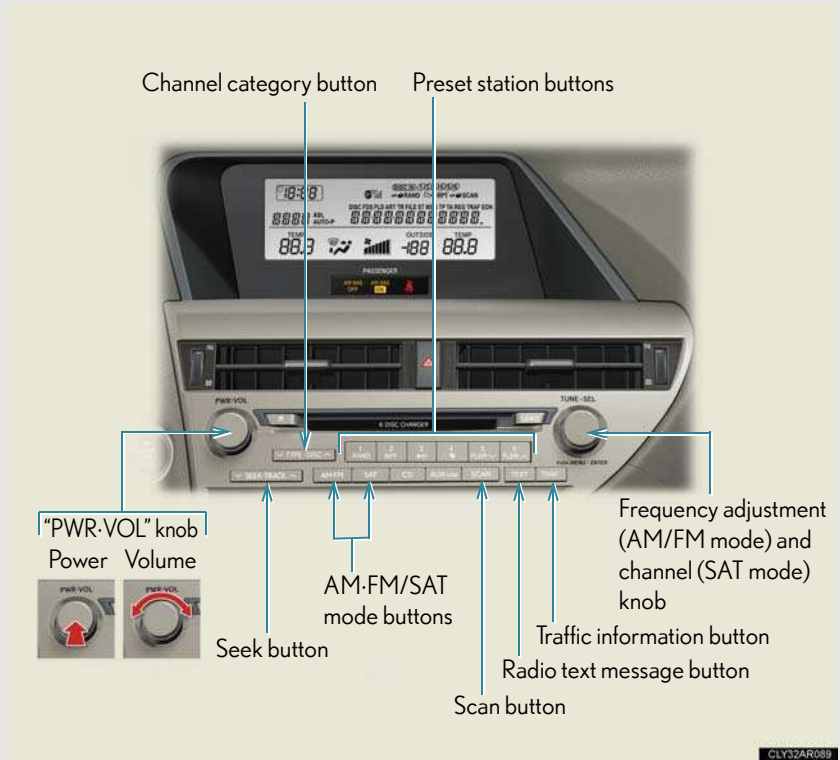

▶ Type B

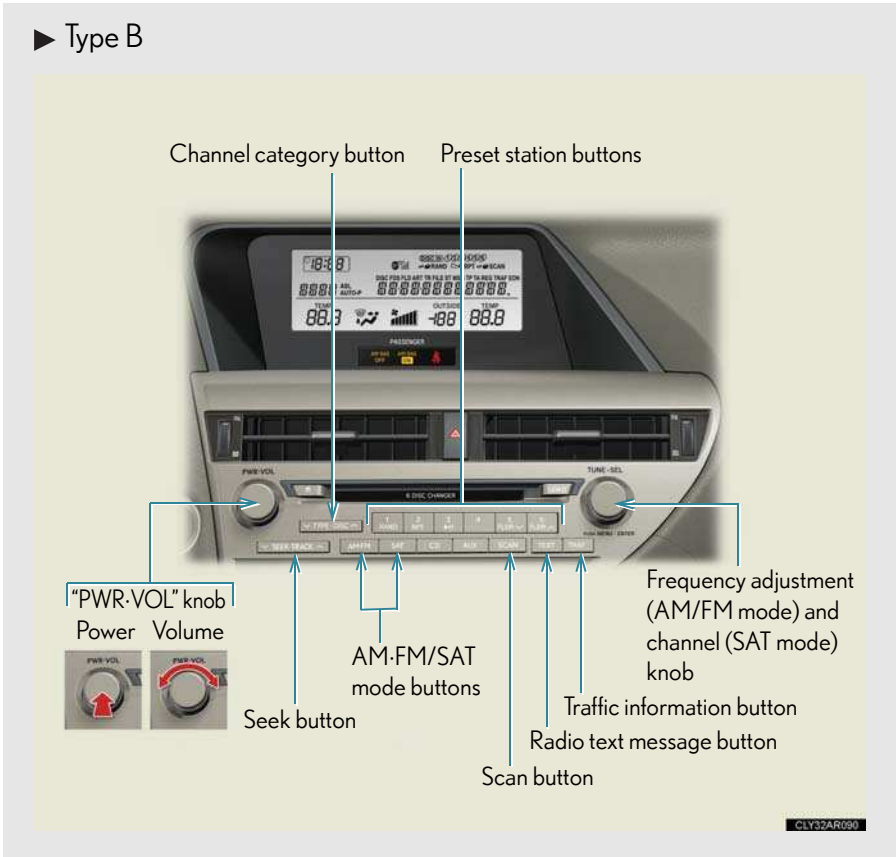

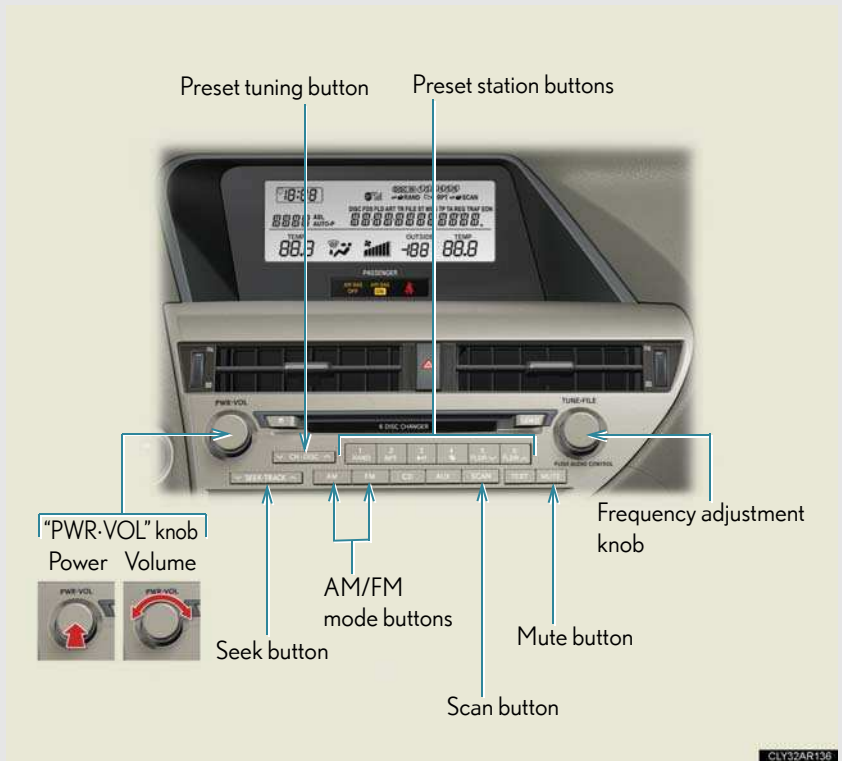

► Type C



CLY32AR136

## Setting station presets (excluding XM<sup>®</sup> Satellite Radio)

**STEP 1** Search for the desired stations by turning  or  or pressing “^” or “v” on .

**STEP 2** Press and hold the button (from  to ) the station is to be set to until you hear a beep.

## Scanning radio stations (excluding XM<sup>®</sup> Satellite Radio)

### n Scanning the preset radio stations

**STEP 1** Press and hold  until you hear a beep.

Preset stations will be played for 5 seconds each.

**STEP 2** When the desired station is reached, press the button again.

### n Scanning all the radio stations within range

**STEP 1** Press .

All the stations with reception will be played for 5 seconds each.

**STEP 2** When the desired station is reached, press the button again.



## RDS (Radio Data System) (type A and B)

This feature allows your radio to receive station identification information and program information (classical, jazz, etc.) from radio stations which broadcast this information.

### n Receiving RDS broadcasts

**STEP 1** Press “^” or “v” on  during FM reception.

The type of program changes each time the button is pressed.

I“ROCK”

I“EASYLIS” (Easy listening)

I“CLS/JAZZ” (Classical music and Jazz)

I“R & B” (Rhythm and Blues)



I“INFORM” (Information)

I“RELIGION”

I“MISC” (Miscellaneous)

I“ALERT” (Emergency messages)

If the system receives no RDS stations, “NO PTY” appears on the display.

**STEP 2** Press , or “^” or “v” on .

The radio seeks or scans for stations of the relevant program type.



n **Displaying radio station names**

Press .

n **Displaying radio text messages**

Press  twice.

A text message is displayed when “MSG” is shown on the screen.

If the text continues past the end of the display,  is displayed. Press and hold  until you hear a beep.



## XM<sup>®</sup> Satellite Radio (type A and B)

n **Receiving XM<sup>®</sup> Satellite Radio**



**STEP 1** Press .

The display changes as follows each time the button is pressed:  
“SAT1” → “SAT2” → “SAT3”



**STEP 2** Turn  to select the desired channel in all the categories or press “^” or “v” on  to select the desired channel in the current category.

n **Setting XM<sup>®</sup> Satellite Radio channel presets**

Select the desired channel. Press and hold the button (from  to ) the channel is to be set to until you hear a beep.

n **Changing the channel category**

Press “^” or “v” on .

## n Scanning the XM<sup>®</sup> Satellite Radio channels

### 1 Scanning the channels in the current category

**STEP 1** Press **SCAN** .

**STEP 2** When the desired channel is reached, press the button again.

### 1 Scanning the preset channels

**STEP 1** Press and hold **SCAN** until you hear a beep.

**STEP 2** When the desired channel is reached, press the button again.

## n Displaying text information

Press **TEXT** .

The display will show up to 10 characters.

The display changes as follows each time the button is pressed:

- 1 CH NAME
- 1 TITLE (SONG/PROGRAM TITLE)
- 1 NAME (ARTIST NAME/FEATURE)
- 1 CH NUMBER

### n **When the battery is disconnected**

All preset stations are erased.

### n **Reception sensitivity**

- l Cargo loaded on the roof luggage carrier, especially metal objects, may adversely affect the reception of XM<sup>®</sup> Satellite Radio (type A and B).
- l It is difficult to maintain perfect radio reception at all times due to the continually changing position of the antenna, differences in signal strength and surrounding objects, such as trains and transmitters.
- l The radio antenna is mounted inside the rear spoiler and the rear window. To maintain clear radio reception, do not attach metallic window tinting or other metallic objects to the antenna wire mounted inside the rear window.

### n **Receiving XM<sup>®</sup> Satellite Radio (type A and B)**

An XM<sup>®</sup> Satellite Radio is a tuner designed exclusively to receive broadcasts provided under a separate subscription. Availability is limited to the 48 contiguous states and 10 Canadian provinces.

#### l XM<sup>®</sup> subscriptions

For detailed information about XM<sup>®</sup> Satellite Radio or to subscribe:  
U.S.A. —

Visit on the web at [www.siriusxm.com](http://www.siriusxm.com) or call 1-877-515-3987.

Canada —

Visit on the web at [www.xmradio.ca](http://www.xmradio.ca) or call 1-877-438-9677.

#### l Radio ID

You will need the radio ID when activating XM<sup>®</sup> service or reporting a problem.



Select “CH000” using , and the receiver's 8-character ID number will appear.

#### l Satellite tuner

The tuner supports only Audio Services (Music and Talk) and the accompanying Text Information of XM<sup>®</sup> Satellite Radio.

**n If the satellite radio does not operate normally**

If a problem occurs with the XM<sup>®</sup> tuner, a message will appear on the display. Refer to the table below to identify the problem, and take the suggested corrective action.

ANTENNA	The XM <sup>®</sup> antenna is not connected. Check whether the XM <sup>®</sup> antenna cable is attached securely.
	There is a short-circuit in the antenna or the surrounding antenna cable. See a Lexus certified dealer.
UNAUTH	You have not subscribed to the XM <sup>®</sup> Satellite Radio. The radio is being updated with the latest encryption code. Contact the XM <sup>®</sup> Satellite Radio for subscription information. When a contract is canceled, you can choose the "CH000" and all the free-to-air channels.
	The premium channel you selected is not authorized. Wait for about 2 seconds until the radio returns to the previous channel or "CH001". If it does not change automatically, select another channel. If you want to listen to the premium channel, contact the XM <sup>®</sup> Satellite Radio.
NO SIGNAL	The XM <sup>®</sup> signal is too weak at the current location. Wait until your vehicle reaches a location with a stronger signal.
LOADING	The unit is acquiring audio or program information. Wait until the unit has received the information.
OFF AIR	The channel you selected is not broadcasting any programming. Select another channel.

-----	There is no song/program title or artist name/feature associated with the channel at that time. No action needed.
CH UNAVL	The channel you selected is no longer available. Wait for about 2 seconds until the radio returns to the previous channel or "CH001". If it does not change automatically, select another channel.

Contact the XM<sup>®</sup> Listener Care Center at 1-877-515-3987 (U.S.A.) or 1-877-438-9677 (Canada).

### **n Certifications for the radio tuner**

This equipment has been tested and found to comply with the limits for a class B digital device, pursuant to Part 15 of the FCC Rules. These limits are designed to provide reasonable protection against harmful interference in a residential installation. This equipment generates, uses and can radiate radio frequency energy and, if not installed and used in accordance with the instructions, may cause harmful interference to radio communications. However, there is no guarantee that interference will not occur in a particular installation.

If this equipment does cause harmful interference to radio or television reception, which can be determined by turning the equipment off and on, the user is encouraged to try to correct the interference by trying one or more of the following:

- 1 Reorienting or relocate the receiving antenna.
- 1 Increasing the separation between the equipment and receiver.
- 1 Connecting the equipment into an outlet on a circuit different from that to which the receiver is connected.
- 1 Consulting the dealer or an experienced radio/TV technician for help.

## 3-2. Using the audio system Using the CD player

### ▶ Type A

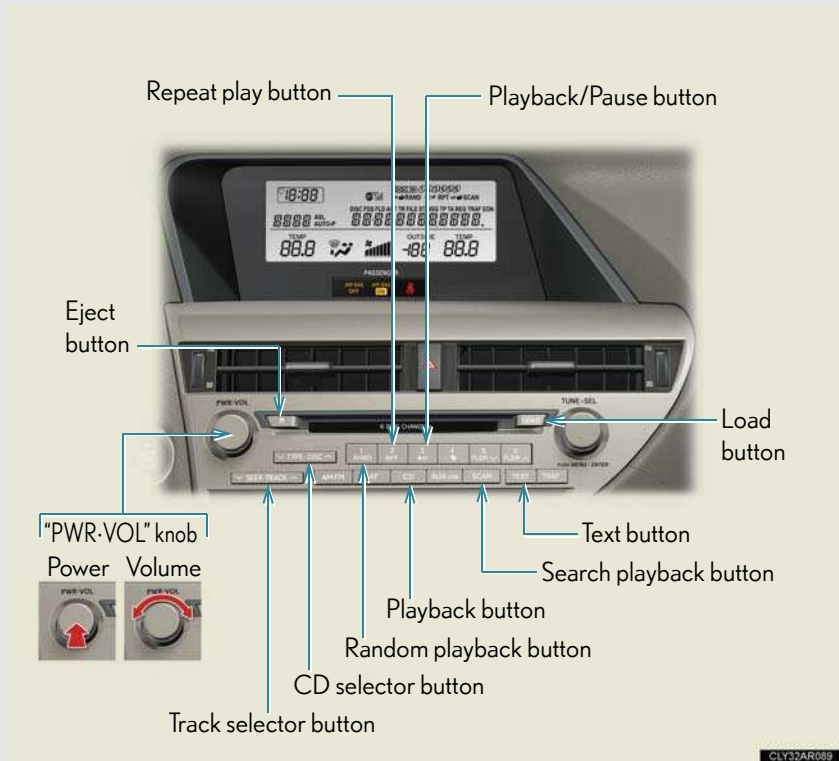

► Type B

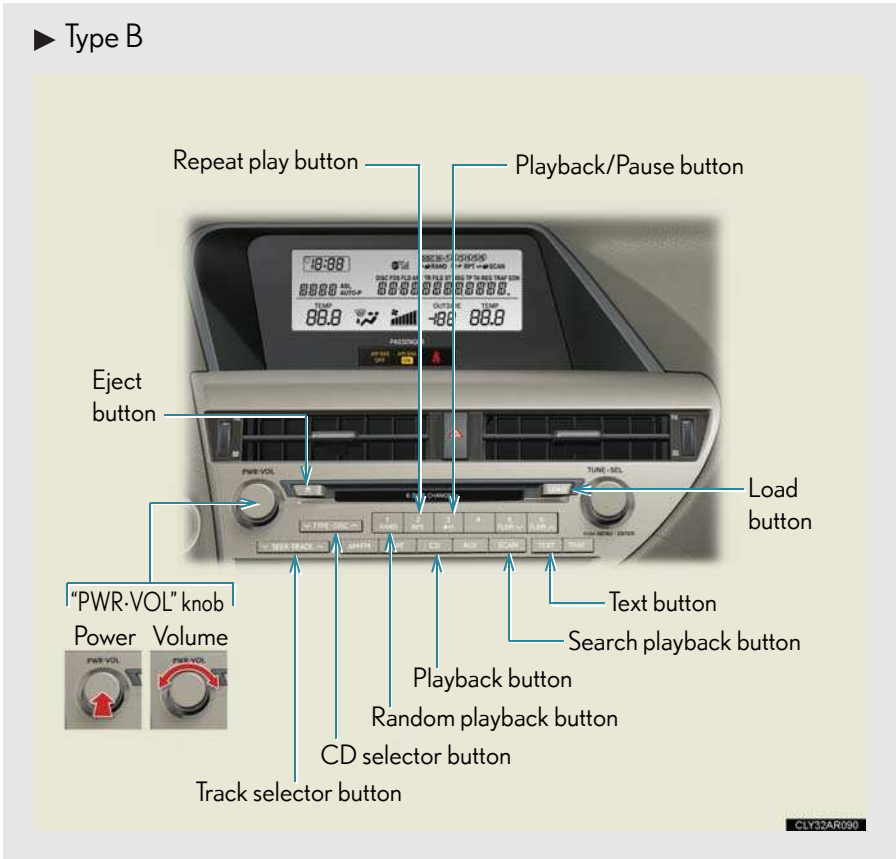



▶ Type C

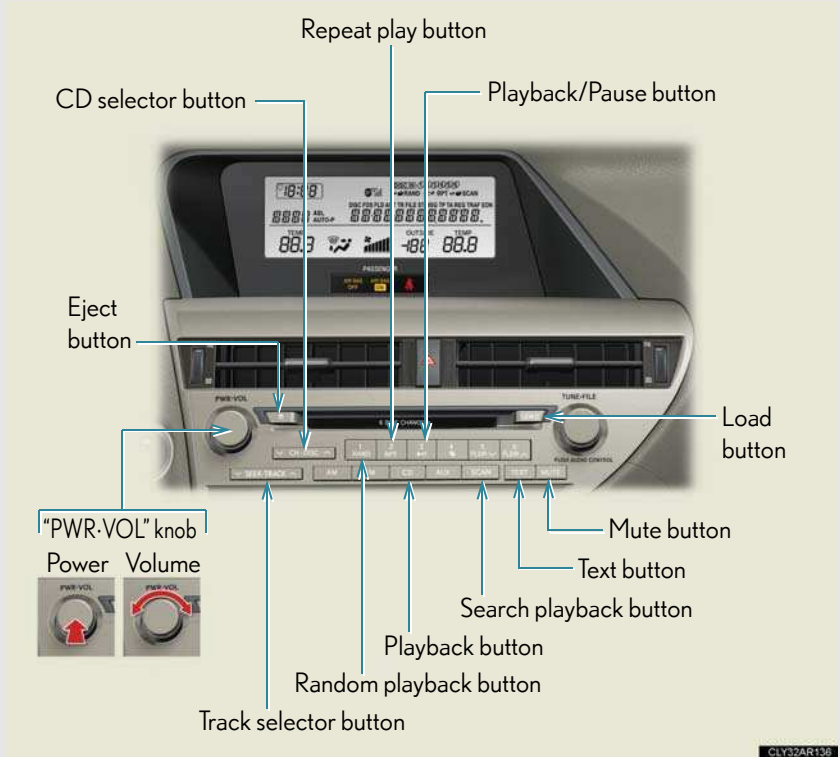

CLY32AR136

## Loading a CD

### n Loading a CD

**STEP 1** Press .

“WAIT” is shown on the display.

**STEP 2** When the indicator on the slot turns from amber to green, insert a CD.

The display changes from “WAIT” to “LOAD”.

### n Loading multiple CDs

**STEP 1** Press and hold  until you hear a beep.

“WAIT” is shown on the display.

**STEP 2** When the indicator on the slot turns from amber to green, insert a CD.

The display changes from “WAIT” to “LOAD”.

The indicator on the slot turns to amber when the CD is being inserted.

**STEP 3** When the indicator on the slot turns from amber to green, insert the next CD.

Repeat the procedure for the remaining CDs.

To cancel the operation, press . If you do not insert a disc within 15 seconds, loading will be canceled automatically.

## Ejecting CDs

### n Ejecting a CD



To select the CD to be ejected, press “^” or “v” on **TYPE: DISC** or **CH-DISC**.

The selected disc number is shown on the display.

**STEP 2** Press  and remove the CD.

### n Ejecting all the CDs

Press and hold  until you hear a beep, and then remove the CDs.

## Selecting, fast-forwarding, reversing and scanning tracks

### n Selecting a track

Press “^” to move up or “v” to move down using **SEEK TRACK** until the desired track number is displayed.

### n Fast-forwarding and reversing tracks

To fast-forward or reverse, press and hold “^” or “v” on **SEEK TRACK** until you hear a beep.

### n Scanning tracks

**STEP 1** Press **SCAN**.

The first ten seconds of each track will be played.

To cancel, press **SCAN** again.

**STEP 2** Press the button again when the desired track is reached.

## Selecting a CD

### n Selecting a CD to play

To select the desired CD, press “^” or “v” on  or .

### n Scanning loaded CDs

**STEP 1** Press and hold  until you hear a beep.

The first ten seconds of the first track on each CD will be played.

To cancel, press  again.

**STEP 2** Press the button again when the desired CD is reached.

## Playing and pausing tracks

To play or pause a track, press .

## Random playback

### n Current CD

Press .

Songs are played in random order.

To cancel, press  again.

### n All CDs

Press and hold  until you hear a beep.

Tracks on all loaded CDs are played in random order.

To cancel, press  again.

## Repeat play

### n Repeating a track

Press .

To cancel, press  again.

### n Repeating all of the tracks on a CD

Press and hold  until you hear a beep.

To cancel, press  again.

## Switching the display

Press .

Each time the button is pressed, the display changes in the following order:  
Elapsed time → CD title → Track title

### n CD player protection feature

To protect the internal components, playback is automatically stopped when a problem is detected.

### n Display

Up to 12 characters can be displayed at a time.

If there are 13 or more characters, pressing and holding  for 1 second or more enables to display the remaining characters.

A maximum of 24 characters can be displayed.

If  is pressed for more than 1 second again or has not been operated for more than 6 seconds, the display will return to the first 12 characters.

Depending on the contents recorded, the characters may not be displayed properly or may not be displayed at all.

### ■ When “ERROR” or “WAIT” is shown on the display

“ERROR”: This indicates a trouble either in the CD or inside the player. The CD may be dirty, damaged, or inserted up-side down.

“WAIT”: This indicates that operation is stopped due to a high temperature inside the player. Wait for a while and then press . If the CD still cannot be played back, contact your Lexus dealer.

### ■ Discs that can be used

Discs with the marks shown below can be used.

Playback may not be possible depending on recording format or disc features, or due to scratches, dirt or deterioration.



CDs with copy-protection features may not be used.

### ■ Lens cleaners

Do not use lens cleaners. Doing so may damage the CD player.

### ■ If discs are left inside the CD player or in the ejected position for extended periods of time

The discs may be damaged and may not play properly.

 NOTICE

**n CDs and adapters that cannot be used**

Do not use the following types of CDs, 3 in. (8 cm) CD adapters or Dual Discs. Doing so may damage the CD player and/or the CD load/eject function.



- 1 CDs that have a diameter that is not 4.7 in. (12 cm)



- 1 Low-quality and deformed CDs



- 1 CDs with a transparent or translucent recording area



- 1 CDs that have had tape, stickers or CD-R labels attached to them, or that have had the label peeled off

### NOTICE

#### **n CD player precautions**

Failure to follow the precautions below may result in serious damage to the CDs or the player itself.

- I Do not insert anything other than CDs into the CD slot.
- I Do not apply oil to the CD player.
- I Store CDs away from direct sunlight.
- I Never try to disassemble any part of the CD player.



- I Do not insert more than one CD at a time.



## 3-2. Using the audio system Playing MP3 and WMA discs

### ▶ Type A

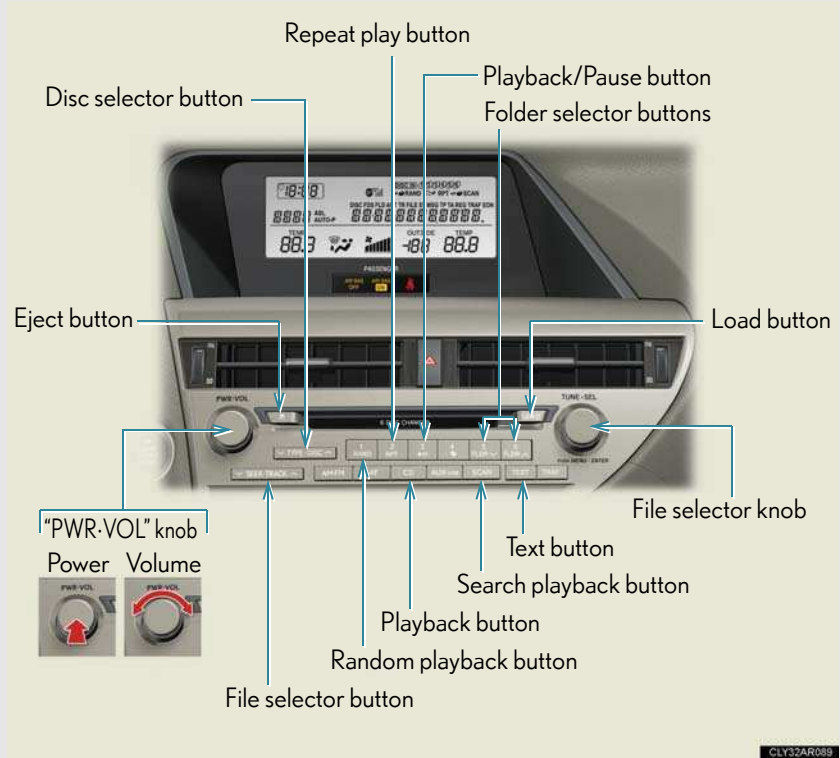

► Type B

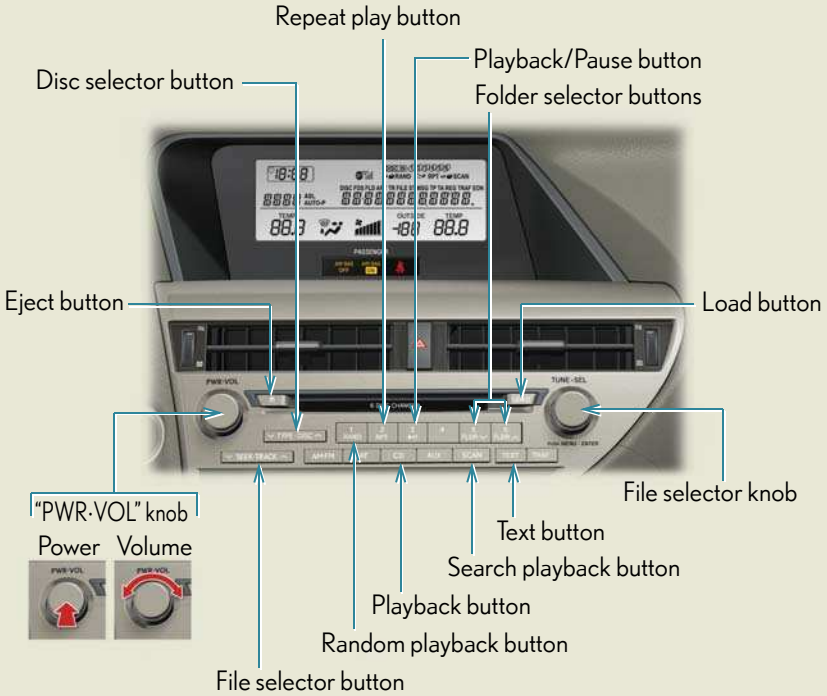

CLY32AR090

► Type C

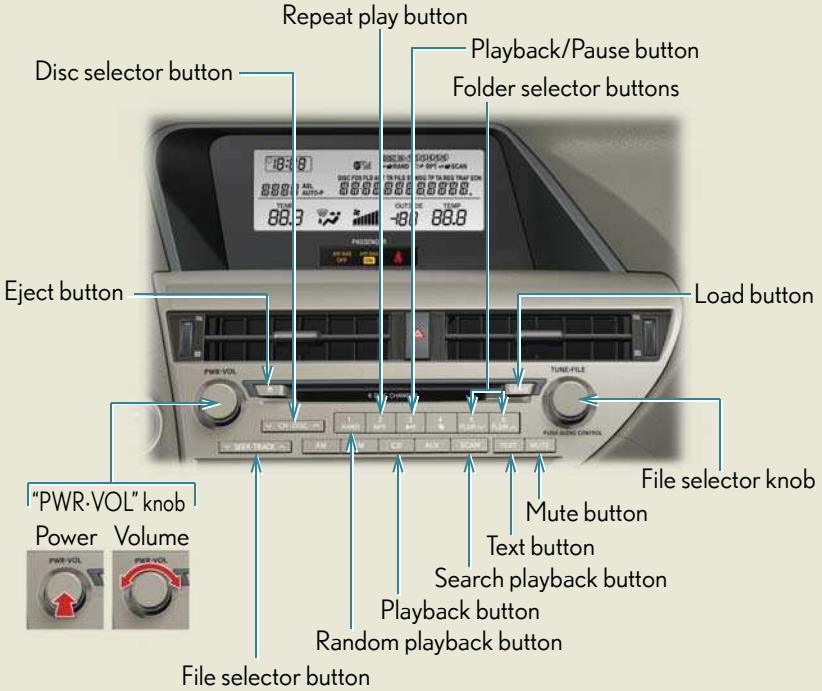

CLY32AR136

### Loading and ejecting MP3 and WMA discs



→P. 300, 301

### Selecting MP3 and WMA discs

→P. 302

### Selecting and scanning a folder

#### n Selecting a folder one at a time

Press  or  to select the desired folder.

#### n Returning to the first folder

Press and hold  until you hear a beep.

#### n Scanning the first file of all the folders

**STEP 1** Press and hold  until you hear a beep.

The first ten seconds of the first file in each folder will be played.



**STEP 2** When the desired folder is reached, press  again.

### Fast-forwarding and reversing files

To fast-forward or reverse, press and hold “^” or “v” on  until you hear a beep.

## Selecting and scanning files

### n Selecting a file

Turn  or  or press “^” or “v” on  to select the desired file.

### n Scanning the files in a folder

Press .

The first ten seconds of each file will be played.

To cancel, press  again.

When the desired file is reached, press  again.

## Playing and pausing files

To play or pause a file, press .

## Random playback

### n Playing files from a folder in random order

Press .

To cancel, press  again.

### n Playing all the files from a disc in random order

Press and hold  until you hear a beep.

To cancel, press  again.

## Repeat play

### n Repeating a file

Press  .

To cancel, press  again.

### n Repeating all the files in a folder

Press and hold  until you hear a beep.

To cancel, press  again.

## Switching the display

Press  .

Each time the button is pressed, the display changes in the following order:  
Folder no./File no./Elapsed time → Folder name → File name → Album title  
(MP3 only) → Track title → Artist name

---

n **CD player protection feature**

→P. 303

n **Display**

→P. 303

n **When “ERROR”, “WAIT” or “NO MUSIC” is shown on the display**

“ERROR”: This indicates a problem either in the CD or inside the player. The CD may be dirty, damaged, or inserted up-side down.

“WAIT”: This indicates that operation is stopped due to a high temperatures inside the player. Wait for a while and then press . If the CD still cannot be played back, contact your Lexus dealer.

“NO MUSIC”: This indicates that an MP3/WMA file is not included in the CD.

n **Discs that can be used**

→P. 304

n **Lens cleaners**

→P. 304

n **If discs are left inside the CD player or in the ejected position for extended periods of time**

→P. 304

### ■ MP3 and WMA files

MP3 (MPEG Audio LAYER 3) is a standard audio compression format.

Files can be compressed to approximately 1/10 of their original size by using MP3 compression.

WMA (Windows Media Audio) is a Microsoft audio compression format.

This format compresses audio data to a size smaller than that of the MP3 format.

There is a limit to the MP3 and WMA file standards that can be used and to the media/formats on which the files are recorded.

#### I MP3 file compatibility

- Compatible standards  
MP3 (MPEG1 LAYER3, MPEG2 LSF LAYER3)
- Compatible sampling frequencies  
MPEG1 LAYER3: 32, 44.1, 48 (kHz)  
MPEG2 LSF LAYER3: 16, 22.05, 24 (kHz)
- Compatible bit rates (compatible with VBR)  
MPEG1 LAYER3: 64, 80, 96, 112, 128, 160, 192, 224, 256, 320 (kbps)  
MPEG2 LSF LAYER3: 64, 80, 96, 112, 128, 144, 160 (kbps)
- Compatible channel modes: stereo, joint stereo, dual channel and monaural

#### I WMA file compatibility

- Compatible standards  
WMA Ver. 7, 8, 9
- Compatible sampling frequencies  
32, 44.1, 48 (kHz)
- Compatible bit rates (only compatible with 2-channel playback)  
Ver. 7, 8: CBR 48, 64, 80, 96, 128, 160, 192 (kbps)  
Ver. 9: CBR 48, 64, 80, 96, 128, 160, 192, 256, 320 (kbps)

#### I Compatible media

Media that can be used for MP3 and WMA playback are CD-Rs and CD-RWs.

Playback in some instances may not be possible if the CD-R or CD-RW is not finalized. Playback may not be possible or the audio may jump if the disc is scratched or marked with fingerprints.



### 1 Compatible disc formats

The following disc formats can be used:

- Disc formats: CD-ROM Mode 1 and Mode 2  
CD-ROM XA Mode 2, Form 1 and Form 2
- File formats: ISO9660 Level 1, Level 2, (Romeo, Joliet)  
MP3 and WMA files written in any format other than those listed above may not play correctly, and their file names and folder names may not be displayed correctly.

Items related to standards and limitations are as follows:

- Maximum directory hierarchy: 8 levels (including the root)
- Maximum length of folder names/file names: 32 characters
- Maximum number of folders: 192 (including the root)
- Maximum number of files per disc: 255

### 1 File names

The only files that can be recognized as MP3/WMA and played are those with the extension .mp3 or .wma.

### 1 Discs containing multi-session recordings

As the audio system is compatible with multi-sessions, it is possible to play discs that contain MP3 and WMA files. However, only the first session can be played.

### 1 ID3 and WMA tags

ID3 tags can be added to MP3 files, making it possible to record the track title, artist name, etc.

The system is compatible with ID3 Ver. 1.0, 1.1, and Ver. 2.2, 2.3 ID3 tags. (The number of characters is based on ID3 Ver. 1.0 and 1.1.)

WMA tags can be added to WMA files, making it possible to record the track title and artist name in the same way as with ID3 tags.

### 1 MP3 and WMA playback

When a disc containing MP3 or WMA files is inserted, all files on the disc are first checked. Once the file check is finished, the first MP3 or WMA file is played. To make the file check finish more quickly, we recommend you do not write in any files other than MP3 or WMA files or create any unnecessary folders.

Discs that contain a mixture of music data and MP3 or WMA format data cannot be played.

### 1 Extensions

If the file extensions .mp3 and .wma are used for files other than MP3 and WMA files, they will be mistakenly recognized and played as MP3 and WMA files. This may result in large amounts of interference and damage to the speakers.

### 1 Playback

- To play MP3 files with steady sound quality, we recommend a fixed bit rate of at least 128 kbps and a sampling frequency of 44.1 kHz.
- CD-R or CD-RW playback may not be possible in some instances, depending on the characteristics of the disc.
- There is a wide variety of freeware and other encoding software for MP3 and WMA files on the market, and depending on the status of the encoding and the file format, poor sound quality or noise at the start of playback may result. In some cases, playback may not be possible at all.
- When files other than MP3 or WMA files are recorded on a disc, it may take more time to recognize the disc and in some cases, playback may not be possible at all.
- Microsoft, Windows, and Windows Media are the registered trademarks of Microsoft Corporation in the U.S.A. and other countries.

#### NOTICE

##### **n CDs and adapters that cannot be used**

→P. 305

##### **n CD player precautions**

→P. 306

## 3-2. Using the audio system

### Operating an iPod\*

Connecting an iPod enables you to enjoy music from the vehicle speakers.

#### 1 Connecting an iPod

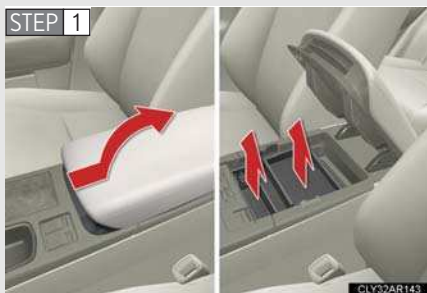

Slide the armrest while pulling up the lever, and lift the armrest. Remove the upper trays (if equipped).



Remove the lower tray.



Open the cover and connect an iPod using an iPod cable.

Turn on the power of the iPod if it is not turned on.

**STEP 4** Press **AUX-USB** or **AUX**.

## n Control panel

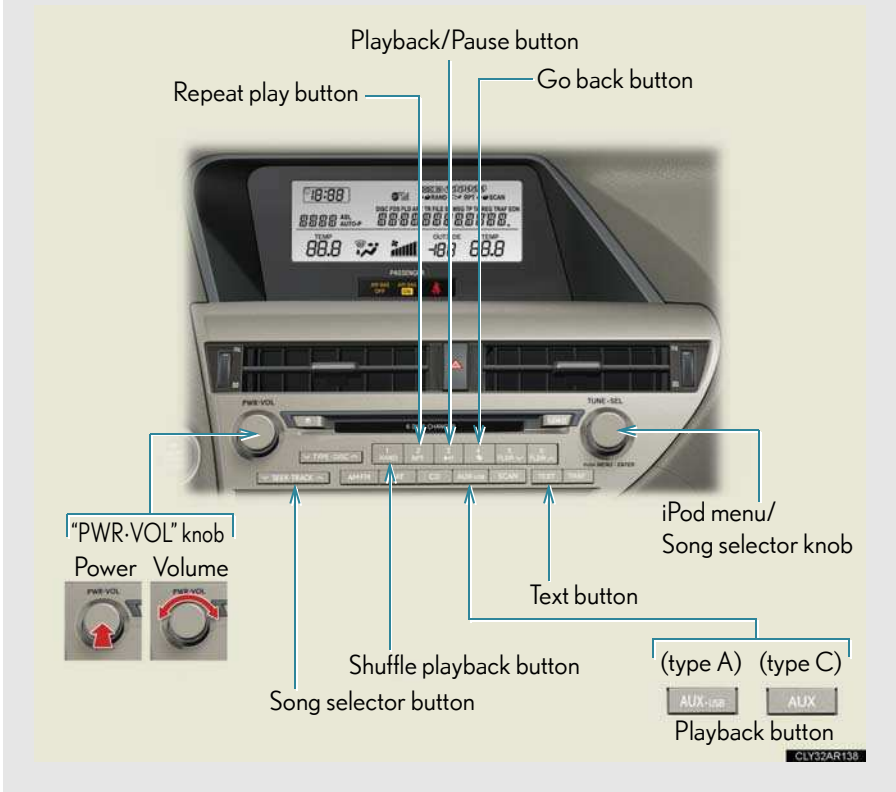

## Selecting a play mode

**STEP 1** Press  to select iPod menu mode.

**STEP 2** Turning  changes the play mode in the following order:

“PLAYLISTS” → “ARTISTS” → “ALBUMS” → “SONGS” →  
 “PODCASTS” → “GENRES” → “COMPOSERS” →  
 “AUDIOBOOKS”

**STEP 3** Press  to select the desired play mode.

n **Play mode list**

Play mode	First selection	Second selection	Third selection	Fourth selection
"PLAYLISTS"	Playlists select	Songs select	-	-
"ARTISTS"	Artists select	Albums select	Songs select	-
"ALBUMS"	Albums select	Songs select	-	-
"SONGS"	Songs select	-	-	-
"PODCASTS"	Albums select	Songs select	-	-
"GENRES"	Genre select	Artists select	Albums select	Songs select
"COMPOSERS"	Composers select	Albums select	Songs select	-
"AUDIOBOOKS"	Songs select	-	-	-

n **Selecting a list**

**STEP 1** Turn  to display the first selection list.

**STEP 2** Press  to select the desired item.

Pressing the knob changes to the second selection list.

**STEP 3** Repeat the same procedure to select the desired song name.

To return to the previous selection list, select "GO BACK" or press



## Selecting songs



Turn  or press “^” or “v” on  to select the desired song.

## Playing and pausing songs

To play or pause a song, press .

## Fast-forwarding and rewinding songs

To fast-forward or rewind, press and hold “^” or “v” on  until you hear a beep.

## Shuffle playback

### n Playing songs from one playlist or album in random order

Press .

To cancel, press  again.

### n Playing songs from all the playlists or albums in random order

Press and hold  until you hear a beep.

To cancel, press  again.

## Repeat play

Press .

To cancel, press  again.

## Switching the display

Press .

Each time the button is pressed, the display changes in the following order:  
Elapsed time → Album title → Track title → Artist name

## Adjusting sound quality and volume balance

**STEP 1** Press  to enter iPod menu mode.

**STEP 2** Pressing  changes sound modes. (→P. 335)

### n About iPod

- 1 Apple is not responsible for the operation of this device or its compliance with safety and regulatory standards.
- 1 iPod is a trademark of Apple Inc., registered in the U.S. and other countries.

### n iPod functions

- 1 When an iPod is connected and the audio source is changed to iPod mode, the iPod will resume play from the same point in which it was last used.
- 1 Depending on the iPod that is connected to the system, certain functions may not be available. If a function is unavailable due to a malfunction (as opposed to a system specification), disconnecting the device and reconnecting it once again may resolve the problem.
- 1 While connected to the system, the iPod cannot be operated with its own controls. It is necessary to use the controls of the vehicle's audio system instead.

### n iPod problems

To resolve most problems encountered when using your iPod, disconnect your iPod from the vehicle iPod connection and reset it.  
For instructions on how to reset your iPod, refer to your iPod Owner's Manual.

### n Display

→P. 303



### n Routing portable audio device cables



When the cover is slide open, portable audio device cables can be pulled through the opening.

### n Error messages

“ERROR”: This indicates a problem in the iPod or its connection.

“NO MUSIC”: This indicates that there is no music data in the iPod.

“EMPTY”: This indicates that an empty playlist is selected.

“UPDATE”: This indicates that the version of the iPod is not compatible. Upgrade your iPod software to the latest version.

### n Compatible models

Model	Generation	Software version
iPod	5th generation	Ver. 1.2.0 or higher
iPod nano	1st generation	Ver. 1.3.0 or higher
	2nd generation	Ver. 1.1.2 or higher
	3rd generation	Ver. 1.0.0 or higher
iPod touch	1st generation	Ver. 1.1.0 or higher
iPod classic	1st generation	Ver. 1.0.0 or higher

Depending on differences between models or software version etc., some models listed above might be incompatible with this system.

iPod 4th generation and earlier models are not compatible with this system.

iPhone, iPod mini, iPod shuffle and iPod photo are not compatible with this system.

Items related to standards and limitations are as follows:

- 1 Maximum number of lists in device: 9999
- 1 Maximum number of songs in device: 65025
- 1 Maximum number of songs per list: 65025

### CAUTION

#### **n Caution while driving**

Do not connect iPod or operate the controls.

### NOTICE

#### **n To prevent damage to iPod**

- 1 Do not leave iPod in the vehicle. The temperature inside the vehicle may become high, resulting in damage to the player.
- 1 Do not push down on or apply unnecessary pressure to the iPod while it is connected as this may damage the iPod or its terminal.
- 1 Do not insert foreign objects into the port as this may damage the iPod or its terminal.

## 3-2. Using the audio system

### Operating a USB memory\*

Connecting a USB memory enables you to enjoy music from the vehicle speakers.

#### n Connecting a USB memory

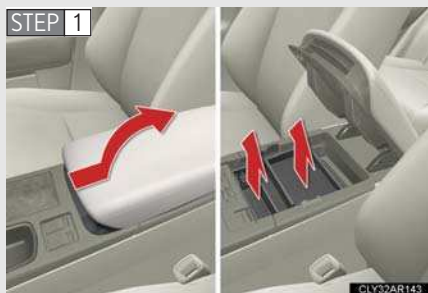

Slide the armrest while pulling up the lever, and lift the armrest. Remove the upper trays (if equipped).

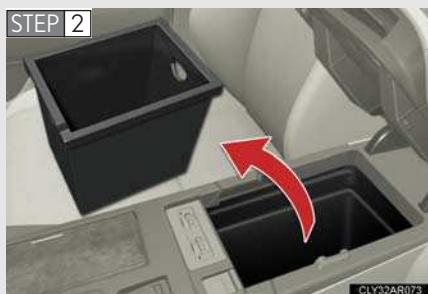

Remove the lower tray.



Open the cover and connect a USB memory.

Turn on the power of the USB memory if it is not turned on.

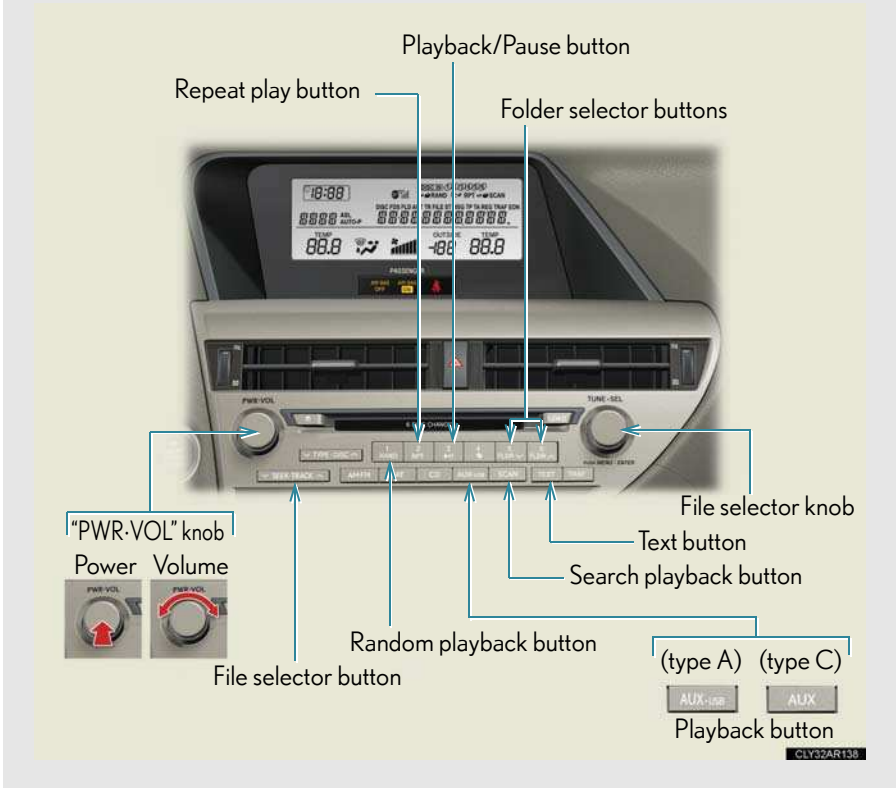

**STEP 4** Press **AUX-156** or **AUX** .

## n Control panel



## Selecting and scanning a folder

### n Selecting folders one at a time

Press  or  to select the desired folder.

### n Returning to the first folder

Press and hold  until you hear a beep.

### n Scanning the first file of all the folders

**STEP 1** Press and hold  until you hear a beep.

The first ten seconds of the first file in each folder will be played.

**STEP 2** When the desired folder is reached, press  again.

## Selecting and scanning files

### n Selecting a file

Turn  or press “^” or “v” on  to select the desired file.

### n Scanning the files in a folder

Press .

The first ten seconds of each file will be played.

To cancel, press  again.

When the desired file is reached, press  again.

## Playing and pausing files

To play or pause a file, press .

### Fast-forwarding and rewinding files

To fast-forward or rewind, press and hold “^” or “v” on  until you hear a beep.

### Random playback

#### n Playing files from a folder in random order

Press .

To cancel, press  again.

#### n Playing all the files from a USB memory in random order

Press and hold  until you hear a beep.

To cancel, press  again.

### Repeat play

#### n Repeating a file

Press .

To cancel, press  again.

#### n Repeating all the files in a folder

Press and hold  until you hear a beep.

To cancel, press  again.

### Switching the display

Press .

Each time the button is pressed, the display changes in the following order:  
Elapsed time → Folder name → File name → Album title → Track title →  
Artist name

---

## n USB memory functions

- 1 Depending on the USB memory that is connected to the system, the device itself may not be operable and certain functions may not be available. If the device is inoperable or a function is unavailable due to a malfunction (as opposed to a system specification), disconnecting the device and reconnecting it once again may resolve the problem.
- 1 If the USB memory still does not begin operation after being disconnected and reconnected, format the memory.

## n Display

→P. 303

## n Routing portable audio device cables

→P. 323

## n Error messages

“ERROR”: This indicates a problem in the USB memory or its connection.

“NO MUSIC”: This indicates that no MP3/WMA files are included in the USB memory.

### n USB memory

#### l Compatible devices

USB memories that can be used for MP3 and WMA playback

#### l Compatible device formats

The following device formats can be used:

- USB communication formats: USB2.0 FS (12 Mbps)
- File formats: FAT16/32 (Windows)
- Correspondence class: Mass storage class

MP3 and WMA files written in any format other than those listed above may not play correctly, and their file names and folder names may not be displayed correctly.

Items related to standards and limitations are as follows:

- Maximum directory hierarchy: 8 levels
- Maximum number of folders in a device: 999 (including the root)
- Maximum number of files in a device: 65025
- Maximum number of files per folder: 255

#### l MP3 and WMA files

MP3 (MPEG Audio LAYER 3) is a standard audio compression format.

Files can be compressed to approximately 1/10 of their original size using MP3 compression.

WMA (Windows Media Audio) is a Microsoft audio compression format.

This format compresses audio data to a size smaller than that of the MP3 format.

There is a limit to the MP3 and WMA file standards that can be used and to the media/formats on which the files are recorded.



### I MP3 file compatibility

- Compatible standards  
MP3 (MPEG1 AUDIO LAYERII, III, MPEG2 AUDIO LAYERII, III, MPEG2.5)
- Compatible sampling frequencies  
MPEG1 AUDIO LAYERII, III: 32, 44.1, 48 (kHz)  
MPEG2 AUDIO LAYERII, III: 16, 22.05, 24 (kHz)  
MPEG2.5: 8, 11.025, 12 (kHz)
- Compatible bit rates (compatible with VBR)  
MPEG1 AUDIO LAYERII, III: 32-320 (kbps)  
MPEG2 AUDIO LAYERII, III: 32-160 (kbps)  
MPEG2.5: 32-160 (kbps)
- Compatible channel modes: stereo, joint stereo, dual channel and monaural

### I WMA file compatibility

- Compatible standards  
WMA Ver. 9
- Compatible sampling frequencies  
HIGH PROFILE 32, 44.1, 48 (kHz)
- Compatible bit rates  
HIGH PROFILE 32-320 (kbps, VBR)

### I File names

The only files that can be recognized as MP3/WMA and played are those with the extension .mp3 or .wma.

### I ID3 and WMA tags

ID3 tags can be added to MP3 files, making it possible to record the track title, artist name, etc.

The system is compatible with ID3 Ver. 1.0, 1.1, and Ver. 2.2, 2.3, 2.4 ID3 tags. (The number of characters is based on ID3 Ver. 1.0 and 1.1.)

WMA tags can be added to WMA files, making it possible to record the track title and artist name in the same way as with ID3 tags.

### I MP3 and WMA playback

- When a device containing MP3 or WMA files is connected, all files in the USB memory device are checked. Once the file check is finished, the first MP3 or WMA file is played. To make the file check finish more quickly, we recommend that you do not include any files other than MP3 or WMA files or create any unnecessary folders.
- When the USB device is connected and the audio source is changed to USB memory mode, the USB device will start playing the first file in the first folder. If the same device is removed and reinserted (and the contents have not been changed), the USB device will resume play from the same point in which it was last used.

### I Extensions

If the file extensions .mp3 and .wma are used for files other than MP3 and WMA files, they will be mistakenly recognized and played as MP3 and WMA files. This may result in large amounts of interference and damage to the speakers.

### I Playback

- To play MP3 files with steady sound quality, we recommend a fixed bit rate of at least 128 kbps and a sampling frequency of 44.1 kHz.
- There is a wide variety of freeware and other encoding software for MP3 and WMA files on the market, and depending on the status of the encoding and the file format, poor sound quality or noise at the start of playback may result. In some cases, playback may not be possible at all.
- Microsoft, Windows, and Windows Media are registered trademarks of Microsoft Corporation in the U.S.A. and other countries.

### CAUTION

#### Caution while driving

Do not connect USB memories or operate the controls.

 NOTICE**n To prevent damage to USB memories**

- 1** Do not leave USB memories in the vehicle. The temperature inside the vehicle may become high, resulting in damage to the player.
- 1** Do not push down on or apply unnecessary pressure to the USB memory while it is connected as this may damage the USB memory or its terminal.
- 1** Do not insert foreign objects into the port as this may damage the USB memory or its terminal.

## 3-2. Using the audio system

### Optimal use of the audio system

#### ► Type A and B



#### ► Type C



**1** Displays the current mode

**2** Changes the following settings:

- Sound quality and volume balance  
→P.335

The sound quality and balance setting can be changed to produce the best sound.

- Automatic Sound Levelizer on/off  
→P.336

## Adjusting sound quality and volume balance

### n Changing sound quality modes

Press  or .

Pressing the button changes sound modes in the following order:

“BAS” → “MID” → “TRE” → “FAD” → “BAL” → “ASL”



### n Adjusting sound quality

Turning  or  adjusts the level.

Mode displayed	Sound quality mode	Level	Turn counter-clockwise	Turn clockwise
“BAS”	Bass*	-5 to 5	Low	High
“MID”	Mid-range*	-5 to 5		
“TRE”	Treble*	-5 to 5		
“FAD”	Front/rear volume balance	F7 to R7	Shifts to rear	Shifts to front
“BAL”	Left/right volume balance	L7 to R7	Shifts to left	Shifts to right

\*: The sound quality level is adjusted individually in each audio mode.

## Turning the Automatic Sound Levelizer (ASL) on/off

Turning  or  clockwise turns on the ASL, and turning 

or  counterclockwise turns off the ASL.

ASL automatically adjusts the volume and tone quality according to the noise level as you drive your vehicle.

## 3-2. Using the audio system

### Using the AUX port

This port can be used to connect a portable audio device and listen to it through the vehicle's speakers.

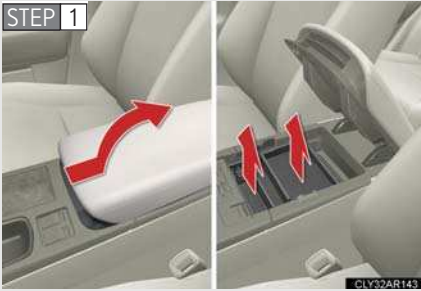

Slide the armrest while pulling up the lever, and lift the armrest. Remove the upper trays (if equipped).

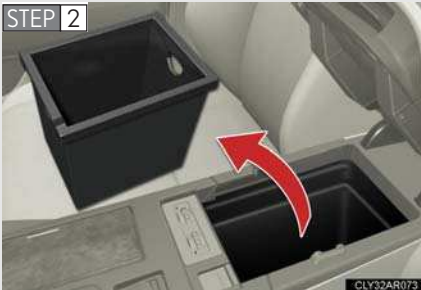

Remove the lower tray.

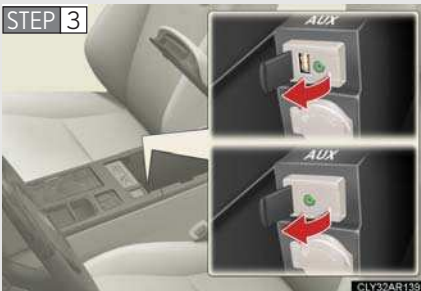

Open the cover and connect the portable audio device.

**STEP 4** Press **AUX-USB** or **AUX**.

### ▮ **Operating portable audio devices connected to the audio system**

The volume can be adjusted using the vehicle's audio controls. All other adjustments must be made on the portable audio device itself.

### ▮ **When using a portable audio device connected to the power outlet**

Noise may occur during playback. Use the power source of the portable audio device.

### ▮ **Routing portable audio device cables**

→P. 323



## 3-2. Using the audio system

# Using the steering wheel audio switches

Some audio features can be controlled using the switches on the steering wheel.



**1** Turns the power on, selects an audio source

**2** Increases/decreases volume

**3** Radio mode: Selects a radio station

CD mode: Selects a track, file (MP3 and WMA) and disc

Bluetooth<sup>®</sup> audio mode (type A and B):

Selects a track and album

iPod mode (type A):

Selects a song

USB memory mode (type A):

Selects a file and folder

### Turning the power on

Press **HOLD** when the audio system is turned off.

The audio system can be turned off by holding the switch down for 1 second or more.

### Changing the audio source

Press  when the audio system is turned on. The audio source changes as follows each time the button is pressed. If no discs are inserted in the player, that mode will be skipped.

Type A:

FM1→FM2→SAT1→SAT2→SAT3→CD player→  
Bluetooth® audio→AUX→iPod or USB memory→AM→FM1

Type B:

FM1→FM2→SAT1→SAT2→SAT3→CD player→  
Bluetooth® audio→AUX→AM→FM1

Type C:

FM1→FM2→CD player→AUX→AM→FM1

### Adjusting the volume

Press “+” on  to increase the volume and “-” to decrease the volume.

Hold down the button to continue increasing or decreasing the volume.

### Selecting a radio station

**STEP 1** Press  to select radio mode.

**STEP 2** Press “^” or “v” on  to select a radio station.

To scan for receivable stations, press and hold “^” or “v” on the button until you hear a beep.

### Selecting a track/file or song

**STEP 1** Press  to select CD, Bluetooth® audio (type A and B), iPod (type A) or USB memory (type A) mode.

**STEP 2** Press “^” or “v” on  to select the desired track/file or song.

### Selecting an album (type A and B)

**STEP 1** Press  to select Bluetooth<sup>®</sup> audio mode.

**STEP 2** Press and hold “^” or “v” on  until you hear a beep.

### Selecting a folder (type A)

**STEP 1** Press  to select USB memory mode.

**STEP 2** Press and hold “^” or “v” on  until you hear a beep.

### Selecting a disc in the CD player

**STEP 1** Press  to select CD mode.

**STEP 2** Press and hold “^” or “v” on  until you hear a beep.

#### n Canceling automatic selection of a radio station

Press  again.

### CAUTION

#### n To reduce the risk of an accident

Exercise care when operating the audio switches on the steering wheel.

### 3-3. Using the Bluetooth® audio system

## Bluetooth® audio system\*

The Bluetooth® audio system enables you to enjoy music played on a portable digital audio player (portable player) from the vehicle speakers via wireless communication.

This audio system supports Bluetooth®, a wireless data system capable of playing portable audio music without cables. If your portable player does not support Bluetooth®, the Bluetooth® audio system will not function.

▶ Vehicles with a navigation system

Owners of models equipped with a navigation system should refer to the "Navigation System Owner's Manual".

▶ Vehicles without a navigation system

Title	Page
Using the Bluetooth® audio system	P. 345
Operating a Bluetooth® enabled portable player	P. 350
Setting up a Bluetooth® enabled portable player	P. 354
Bluetooth® audio system setup	P. 361

#### n Conditions under which the system will not operate

- 1 If using a portable player that does not support Bluetooth®
- 1 If the portable player is switched off
- 1 If the portable player is not connected
- 1 If the portable player's battery is low
- 1 If the portable player is behind the seat or in the glove box or console box
- 1 If metal is covering or touching the portable player

\*: If equipped

### n When transferring ownership of the vehicle

Be sure to initialize the system to prevent personal data from being improperly accessed. (→P. 388)

### n About Bluetooth®



Bluetooth is a registered trademark of Bluetooth SIG, Inc.

### n Compatible models

#### l Bluetooth® specifications:

Ver. 1.2, or higher (Recommended: Ver. 2.0+EDR or higher)

#### l Following Profiles:

- A2DP (Advanced Audio Distribution Profile) Ver. 1.0
- AVRCP (Audio/Video Remote Control Profile) Ver. 1.0 or higher (Ver. 1.3 or higher recommended)

Portable players must correspond to the above specifications in order to be connected to the Bluetooth® audio system. However, please note that some functions may be limited depending on the type of portable player.

### n Certification for the Bluetooth® audio system

FCC ID: AJDK018

IC ID: 775E-K018

MADE IN JAPAN

This device complies with Part 15 of the FCC Rules and RSS-Gen of IC Rules. Operation is subject to the following two conditions: (1) This device may not cause harmful interference, and (2) This device must accept any interference received, including interference that may cause undesired operation.

 **CAUTION**

**n FCC WARNING**

Changes or modifications not expressly approved by the party responsible for compliance could void the user's authority to operate the equipment.

**Radio Frequency Radiation Exposure.** This equipment complies with FCC radiation exposure limits set forth for uncontrolled equipment and meets the FCC radio frequency (RF) Exposure Guidelines in Supplement C to OET65. This equipment has very low levels of RF energy that it deemed to comply without maximum permissive exposure evaluation (MPE). But it is desirable that it should be installed and operated with at least 7.9 in. (20 cm) and more between the radiator and person's body (excluding extremities: hands, wrists, feet and legs).

This transmitter must not be co-located or operated in conjunction with any other antenna or transmitter.

**n Caution while driving**

Do not connect portable players or operate the controls.

 **NOTICE**

**n To prevent damage to portable players**

Do not leave portable players in the vehicle. The temperature inside the vehicle may become high, resulting in damage to the player.

### 3-3. Using the Bluetooth® audio system

## Using the Bluetooth® audio system

#### n Audio unit

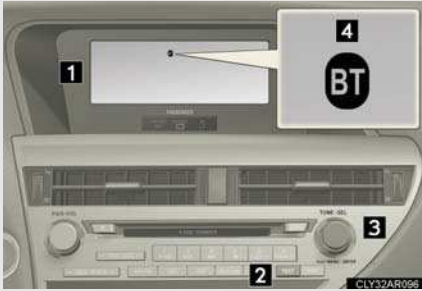

- 1** Display  
A message, name, number, etc. is displayed.  
Lower-case characters and special characters cannot be displayed.
- 2** Displays information that is too long to be displayed at one time on the display (press and hold)
- 3** Selects items such as menu and number  
Turn: Selects an item  
Press: Inputs the selected item
- 4** Bluetooth® connection condition  
If “BT” is not displayed, the Bluetooth® audio system cannot be used.

#### Operating the system using voice commands

By following voice guidance instructions output from the speaker, voice commands enable to the operation of the Bluetooth® audio system without the need to check the display or operate



#### n **Operation procedure when using voice commands**

Press the talk switch and follow voice guidance instructions.

#### n **Auxiliary commands when using voice commands**

The following auxiliary commands can be used when operating the system using a voice command:

“Cancel”: Exits the Bluetooth® audio system

“Repeat”: Repeats the previous voice guidance instruction

“Go back”: Returns to the previous procedure

“Help”: Reads aloud the function summary if a help comment is registered for the selected function



## Using the Bluetooth® audio system for the first time

Before using the Bluetooth® audio system, it is necessary to register a Bluetooth® enabled portable player in the system. Follow the procedure below to register (pair) a portable player:

**STEP 1**

Press  and select “BT•A MENU” using .

**STEP 2**

Press the talk switch or select “BT•A Setup” using .

The introductory guidance and portable player name registration instructions are heard.

**STEP 3**

Select “Pair Audio Player (Pair Audio)” using a voice command

or .

**STEP 4**

Register a portable player name by either of the following methods:

a. Select “Record Name” using , and say the name to be registered.

b. Press the talk switch and say the name to be registered.

A voice guidance instruction to confirm the input is heard.

**STEP 5**

Select “Confirm” using a voice command or .

A passkey is displayed and heard, and a voice guidance instruction for inputting the passkey into the portable player is heard.

**STEP 6**

Input the passkey into the portable player.

Refer to the manual that comes with the portable player for the operation of the portable player.

Guidance for registration completion is heard.

If the portable player has a Bluetooth® phone, the phone can be registered at the same time. A voice guidance instruction to register a Bluetooth® phone is heard.

**STEP 7** Select “Yes” or “No” using a voice command or  .

(Bluetooth® phone →P. 364)

#### Menu list of the Bluetooth® audio system

##### n Normal operation

First menu	Second menu	Third menu	Operation detail
“Setup”	“BT·A Setup”	“Pair Audio”	Registering a portable player
		“Connect”	Selecting a portable player to be used
		“Change Name”	Changing the registered name of a portable player
		“List Audios”	Listing the registered portable players
		“Set Passkey”	Changing the passkey
		“Delete Audio”	Deleting a registered portable player
	“System Setup”	“Guidance Vol”	Setting voice guidance volume
		“Device Name”	Displaying the Bluetooth® device address and name
		“Initialize”	Initializing the system

---

**n When using a voice command**

For numbers, say a combination of single digits from zero to nine.

Say the command correctly and clearly.

**n Situations that the system may not recognize your voice**

l When driving on rough roads

l When driving at high speeds

l When air is blowing out of the vents onto the microphone

l When the air conditioning fan emits a loud noise

**n Operations that cannot be performed while driving**

l Operating the system with



l Registering a portable player to the system

**n Changing the passkey**

→P. 359

### 3-3. Using the Bluetooth® audio system Operating a Bluetooth® enabled portable player

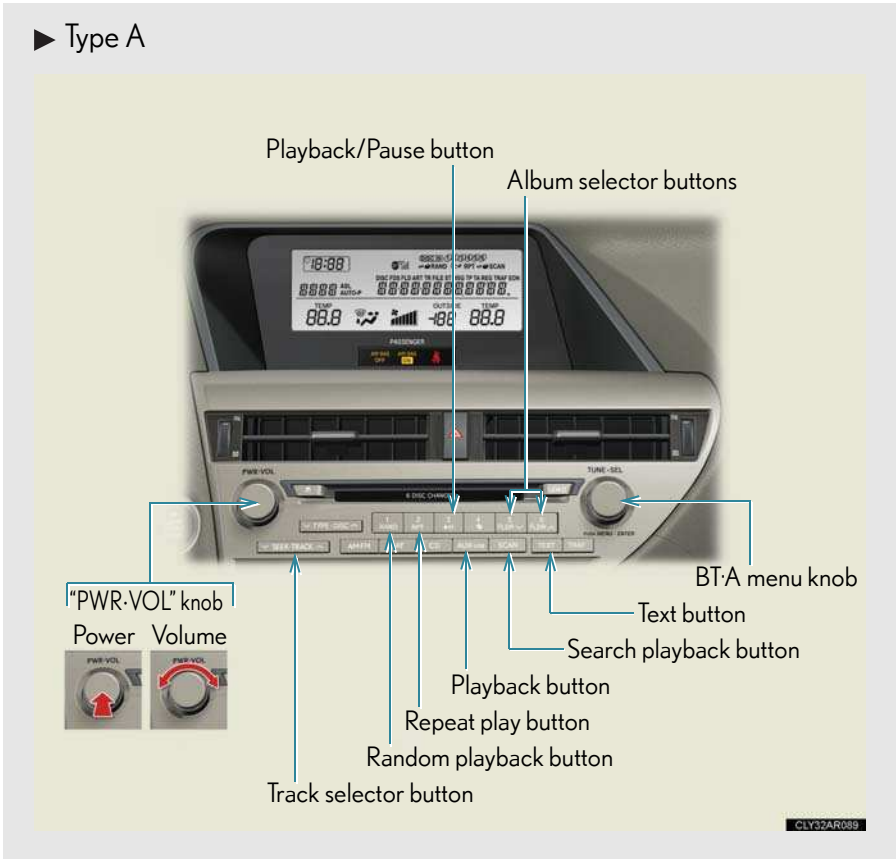

#### ▶ Type A

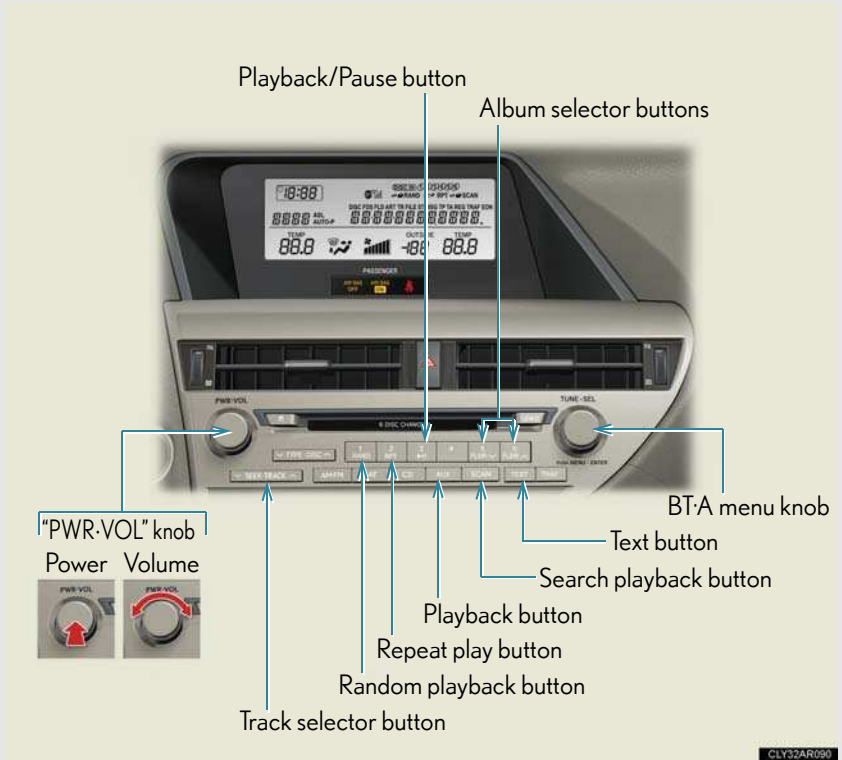

▶ Type B



#### Selecting an album

To select the desired album, press  or .

#### Selecting tracks

Press “^” or “v” on  to select the desired track.

#### Playing and pausing tracks

To play or pause a track, press .

#### Fast-forwarding and rewinding tracks

To fast-forward or rewind, press and hold “^” or “v” on  until you hear a beep.

#### Random playback

Press .

To cancel, press  again.

#### Repeat play

Press .

To cancel, press  again.

#### Scanning tracks

Press .

To cancel, press  again.

## Switching the display

Press **TEXT** .

Each time the button is pressed, the display changes in the following order:  
Elapsed time → Album title → Track title → Artist name

## Using the steering wheel audio switches

→P. 339

### n Bluetooth® audio system functions

Depending on the portable player that is connected to the system, certain functions may not be available.

### n Display

→P. 303

### n Error messages

“Memory Error”: This indicates a problem in the system.

### 3-3. Using the Bluetooth® audio system

## Setting up a Bluetooth® enabled portable player

Registering a portable player in the Bluetooth® audio system allows the system to function. The following functions can be used for registered portable players:

#### n Functions and operation procedures

##### ► Pattern A

To enter the menu for each function, follow the steps below using a

voice command or  :

- 1 Registering a portable player
  1. "Setup" → 2. "Bluetooth Audio Setup (BT•A Setup)" → 3. "Pair Audio Player (Pair Audio)"
- 1 Selecting a portable player to be used
  1. "Setup" → 2. "Bluetooth Audio Setup (BT•A Setup)" → 3. "Connect Audio Player (Connect)"
- 1 Changing the registered name of a portable player
  1. "Setup" → 2. "Bluetooth Audio Setup (BT•A Setup)" → 3. "Change Name"
- 1 Listing the registered portable players
  1. "Setup" → 2. "Bluetooth Audio Setup (BT•A Setup)" → 3. "List Audio Players (List Audios)"
- 1 Changing the passkey
  1. "Setup" → 2. "Bluetooth Audio Setup (BT•A Setup)" → 3. "Set Passkey"
- 1 Deleting a registered portable player
  1. "Setup" → 2. "Bluetooth Audio Setup (BT•A Setup)" → 3. "Delete Audio Player (Delete Audio)"



## ▶ Pattern B

**STEP 1** Press  to select "BT•A MENU".

**STEP 2** Press the talk switch or select "BT•A Setup" using .

**STEP 3** Select one of the following functions using a voice command

or .

- 1 Registering a portable player  
"Pair Audio Player (Pair Audio)"
- 1 Selecting a portable player to be used  
"Connect Audio Player (Connect)"
- 1 Changing the registered name of a portable player  
"Change Name"
- 1 Listing the registered portable players  
"List Audio Players (List Audios)"
- 1 Changing the passkey  
"Set Passkey"
- 1 Deleting a registered portable player  
"Delete Audio Player (Delete Audio)"

## Registering a portable player

Select “Pair Audio Player (Pair Audio)” using a voice command or , and perform the procedure for registering a portable player. (→P. 347)

## Selecting a portable player to be used

**STEP 1** Select “Connect Audio Player (Connect)” using a voice com-

mand or



► Pattern A

**STEP 2** Select the portable player to be used by either of the following methods, and select “Confirm” by using a voice command or



- Press the talk switch and say the name of the desired portable player.
- Press the talk switch and say “List Audio Players”. When the name of the desired portable player is read aloud, press the talk switch.

► Pattern B

**STEP 2** Select the portable player to be used using



## ▶ Pattern A

**STEP 3** Press the talk switch and say “From Car” or “From Audio player”, and select “Confirm” by using a voice command or .

## ▶ Pattern B

**STEP 3** Select “From Car” or “From Audio”, using .

If “From Car” is selected, the portable player will be automatically connected whenever the “ENGINE START STOP” switch is in either ACCESSORY or IGNITION ON mode.

### Changing the registered name of a portable player

**STEP 1** Select “Change Name” using a voice command or .

## ▶ Pattern A

**STEP 2** Select the name of the portable player to be changed by either of the following methods, and select “Confirm” using a voice com-

mand or  :

- Press the talk switch and say the name of desired portable player.
- Press the talk switch and say “List Audio Players”. When the name of the desired portable player is read aloud, press the talk switch.

► Pattern B

**STEP 2** Select the desired portable player name to be changed using



**STEP 3** Press the talk switch or select "Record Name" using , and say the new name.

**STEP 4** Select "Confirm" using a voice command or



### Listing the registered portable players

Select "List Audio Players (List Audios)" using a voice command or



. The list of registered portable players will be read aloud.

When listing is complete, the system returns to "BT•A Setup".

Pressing the talk switch while the name of a portable player is being read aloud selects the portable player, and the following functions will become available:

- 1 Selecting a portable player: "Connect Audio Player (Connect)"
- 1 Changing a registered name: "Change Name"
- 1 Deleting a portable player: "Delete Audio Player (Delete Audio)"

## Changing the passkey

**STEP 1** Select “Set Passkey” using a voice command or



► Pattern A

**STEP 2** Press the talk switch, say a 4 to 8-digit number, and select “Confirm” using a voice command or



► Pattern B

**STEP 2** Select a 4 to 8-digit number using



The number should be input 1 digit at a time.

**STEP 3** When the entire number to be registered as a passkey has been input, press



again.

If the number to be registered has 8 digits, pressing of the knob is not necessary.

## Deleting a registered portable player

**STEP 1** Select “Delete Audio Player (Delete Audio)” using a voice com-

mand or



### ► Pattern A

**STEP 2** Select the portable player to be deleted by either of the following

methods and select “Confirm” using a voice command or



a. Press the talk switch and say the name of the desired portable player.

b. Press the talk switch and say “List Audio Players”. When the name of the desired portable player is read aloud, press the talk switch.

### ► Pattern B

**STEP 2** Select the desired portable player to be deleted using



If the portable player to be deleted is paired as a Bluetooth® phone, the registration of the mobile phone can be deleted at the same time. A voice guidance instruction to delete a mobile phone is heard.

**STEP 3** Select “Yes” or “No” using a voice command or



(Bluetooth® phone →P. 364)

### n The number of portable players that can be registered

Up to 2 portable players can be registered in the system.

### 3-3. Using the Bluetooth® audio system

## Bluetooth® audio system setup

#### n System setup items and operation procedures

##### ▶ Pattern A

To enter the menu for each function, follow the steps below using a

voice command or  :

(→P. 385)

##### ▶ Pattern B

**STEP 1** Press  to select “BT•A MENU”.

**STEP 2** Select “System Setup” using  .

**STEP 3** Select one of the following items using  :

- 1 Setting voice guidance volume  
“Guidance Vol” (→P. 387)
- 1 Displaying the Bluetooth® device address and name  
“Device Name” (→P. 387)
- 1 Initializing the system  
“Initialize” (→P. 388)

### 3-4. Using the hands-free phone system (for mobile phones)

## Hands-free system for mobile phones\*

The hands-free system is a function that allows you to use your mobile phone without touching it.

This system supports Bluetooth® mobile phones. Bluetooth® is a wireless data system that allows the mobile phone to wirelessly connect to the hands-free system and make/receive calls.

▶ Vehicles with a navigation system

Owners of models equipped with a navigation system should refer to the "Navigation System Owner's Manual".

▶ Vehicles without a navigation system

Title	Page
Using the hands-free system	P. 366
Making a phone call	P. 374
Setting a mobile phone	P. 379
Security and system setup	P. 385
Using the phone book	P. 389

\*: If equipped



**n Conditions under which the system will not operate**

- l If using a mobile phone that does not support Bluetooth®
- l If the mobile phone is switched off
- l If you are outside service range
- l If the mobile phone is not connected
- l If the mobile phone's battery is low
- l If the mobile phone is behind the seat or in the glove box or console box
- l If metal is covering or touching the phone

**n When using the hands-free system**

- l The audio system and voice guidance are muted when making a call.
- l If both parties speak at the same time, it may be difficult to hear.
- l If the incoming call volume is overly loud, an echo may be heard.
- l Try to face toward the microphone as much as possible when speaking.
- l In the following circumstances, it may be difficult to hear the other party:
  - When driving on unpaved roads
  - When driving at high speeds
  - When a window is open
  - When the air conditioning is blowing directly on the microphone
  - When the air conditioning is set to high

**n When transferring ownership of the vehicle**

Be sure to initialize the system to prevent personal data from being improperly accessed. (→P. 388)

**n About Bluetooth®**

Bluetooth is a registered trademark of Bluetooth SIG, Inc.

## 3-4. Using the hands-free phone system (for mobile phones)

### n **Compatible models**

Compatible with HFP (Hands Free Profile) Ver. 1.5 and OPP (Object Push Profile) Ver. 1.1.

If your mobile phone does not support HFP, you cannot enter the Bluetooth® phone. If your mobile phone supports OPP alone, you cannot use the Bluetooth® phone.

### n **Certification for the hands-free system**

FCC ID: AJDK018

IC ID: 775E-K018

MADE IN JAPAN

This device complies with Part 15 of the FCC Rules and RSS-Gen of IC Rules. Operation is subject to the following two conditions: (1) This device may not cause harmful interference, and (2) This device must accept any interference received, including interference that may cause undesired operation.

### **CAUTION**

#### n **FCC WARNING**

Changes or modifications not expressly approved by the party responsible for compliance could void the user's authority to operate the equipment.

Radio Frequency Radiation Exposure. This equipment complies with FCC radiation exposure limits set forth for uncontrolled equipment and meets the FCC radio frequency (RF) Exposure Guidelines in Supplement C to OET65. This equipment has very low levels of RF energy that it deemed to comply without maximum permissive exposure evaluation (MPE). But it is desirable that it should be installed and operated with at least 7.9 in. (20 cm) and more between the radiator and person's body (excluding extremities: hands, wrists, feet and legs).

This transmitter must not be co-located or operated in conjunction with any other antenna or transmitter.

#### n **Caution while driving**

Do not use a mobile phone or connect the Bluetooth® phone.

 NOTICE

**n To prevent damage to mobile phones**

Do not leave mobile phones in the vehicle. The temperature inside the vehicle may become high, resulting in damage to the phone.

## 3-4. Using the hands-free phone system (for mobile phones)

### Using the hands-free system (for mobile phones)

#### n Audio unit

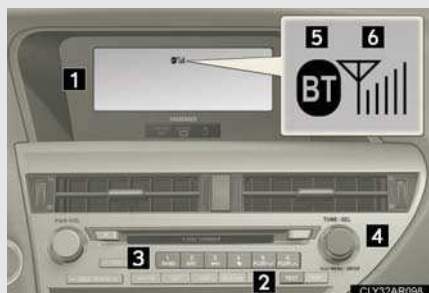

- 1** Display  
A message, name, phone number, etc. is displayed.  
Lower-case characters and special characters cannot be displayed.
- 2** Displays information that is too long to be displayed at one time on the display (press and hold)
- 3** Selects speed dials
- 4** Selects items such as menu and number  
Turn: Selects an item  
Press: Inputs the selected item
- 5** Bluetooth<sup>®</sup> connection condition  
If "BT" is not displayed, the hands-free phone system cannot be used.
- 6** Reception level

## n Steering wheel switches



### 1 Volume

The voice guidance volume cannot be adjusted using this button.

### 2 Off-hook switch

Turns the hands-free system on/starts a call

### 3 On-hook switch

Turns the hands-free system off/ends a call/refuses a call

### 4 Talk switch

Turns the voice command system on (press)/turns the voice command system off (press and hold)

## n Microphone



## Operating the system using voice commands

By following voice guidance instructions output from the speaker, voice commands enable the operation of the hands-free phone system with-

out the need to check the display or operate



### n **Operation procedure when using voice commands**

Press the talk switch and follow voice guidance instructions.

### n **Auxiliary commands when using voice commands**

The following auxiliary commands can be used when operating the system using a voice command:

“Cancel”: Exits the hands-free phone system

“Repeat”: Repeats the previous voice guidance instruction

“Go back”: Returns to the previous procedure

“Help”: Reads aloud the function summary if a help comment is registered for the selected function

## Using the hands-free phone system for the first time

Before using the hands-free phone system, it is necessary to register a mobile phone in the system. The system will enter phone registration mode automatically when starting the system with no mobile phone registered. Follow the procedure below to register (pair) a mobile phone:

**STEP 1** Press the off-hook switch or the talk switch.

The introductory guidance and phone name registration instructions are heard.

**STEP 2** Select “Pair Phone” using a voice command or



**STEP 3** Register a phone name by either of the following methods:

- a. Select “Record Name” using , and say the name to be registered.
- b. Press the talk switch and say the name to be registered.

A voice guidance instruction to confirm the input is heard.

**STEP 4** Select “Confirm” using a voice command or



A passkey is displayed and heard, and a voice guidance instruction for inputting the passkey into the mobile phone is heard.

**STEP 5** Input the passkey into the mobile phone.

Refer to the manual that comes with the mobile phone for the operation of the phone.

Guidance for registration completion is heard.

If the mobile phone has a Bluetooth<sup>®</sup> audio player, the audio player can be registered at the same time. A voice guidance instruction to register a Bluetooth<sup>®</sup> audio player is heard.

**STEP 6** Select “Yes” or “No” using a voice command or



(Bluetooth® audio player →P. 343)

**Menu list of the hands-free phone system**

**n Normal operation**

First menu	Second menu	Third menu	Operation detail
“Callback”	-	-	Dialing a number stored in the incoming call history memory
“Redial”	-	-	Dialing a number stored in the outgoing call history memory
“Phonebook”	“Add Entry”	-	Adding a new phone number
	“Change Name”	-	Changing the registered name in the phone book
	“Delete Entry”	-	Deleting the registered data
	“Del Spd Dial”	-	Deleting speed dials
	“List Names”	-	Listing the registered data
	“Speed Dial”	-	Setting speed dials



First menu	Second menu	Third menu	Operation detail
"Setup"	"Security"	"Set PIN"	Setting a PIN code
		"Phbk Lock"	Locking the phone book
		"Phbk Unlock"	Unlocking the phone book
	"Phone Setup"	"Pair Phone"	Registering the mobile phone to be used
		"Connect"	Selecting a mobile phone to be used
		"Change Name"	Changing a registered name of a mobile phone
		"List Phones"	Listing the registered mobile phones
		"Set Passkey"	Changing the passkey
		"Delete Phone"	Deleting a registered mobile phone
	"System Setup"	"Guidance Vol"	Setting voice guidance volume
		"Device Name"	Displaying the Bluetooth <sup>®</sup> device address and name
"Initialize"		Initializing the system	

n Using a short cut key

First menu	Second menu	Operation detail
"Dial XXX (name)"	-	Dialing a name registered in the phone book
"Phone book add Entry"	-	Adding a new phone number
"Phone book Change name"	-	Changing a registered name in the phone book
"Phone book Delete Entry"	-	Deleting the registered data
"Phone book List names"	-	Listing the registered data
"Phone book Set Speed Dial"	-	Setting speed dials
"Phone book Delete Speed Dial"	-	Deleting speed dials
"Dial XXX (number)"	-	Dialing by inputting a number
"Phonebook"	"Phonebook Unlock"	Unlocking the phone book
	"Phonebook Lock"	Locking the phone book

n **Automatic volume adjustment**

When vehicle speed reaches 50 mph (80 km/h) or more, the volume automatically increases. The volume returns to the previous volume setting when vehicle speed drops to 43 mph (70 km/h) or less.

n **When using a voice command**

For numbers, say a combination of single digits from zero to nine, # (pound), \* (star), and + (plus).

Say the command correctly and clearly.

n **Situations that the system may not recognize your voice**

l When driving on rough roads

l When driving at high speeds

l When air is blowing out of the vents onto the microphone

l When the air conditioning fan emits a loud noise

n **Operations that cannot be performed while driving**

l Operating the system with



l Registering a mobile phone to the system

n **Changing the passkey**

→P. 382

### 3-4. Using the hands-free phone system (for mobile phones)

## Making a phone call

#### n Making a phone call

- 1 Dialing by inputting a number  
“Dial by number”
- 1 Dialing by inputting a name  
“Dial by name”
- 1 Speed dialing
- 1 Dialing a number stored in the outgoing history memory  
“Redial”
- 1 Dialing a number stored in the incoming history memory  
“Call back”

#### n Receiving a phone call

- 1 Answering the phone
- 1 Refusing the call

#### n Transferring a call

#### n Call waiting

#### n Using the call history memory

- 1 Dialing
- 1 Storing number in the phone book
- 1 Deleting

### Dialing by inputting a number

**STEP 1** Press the talk switch and say “Dial by number”.

**STEP 2** Press the talk switch and say the phone number.

**STEP 3** Dial by one of the following methods:

- a. Press the off-hook switch.
- b. Press the talk switch and say “Dial”.

- c. Select “Dial” using .



### Dialing by inputting a name

**STEP 1** Press the talk switch and say “Dial by name”.

**STEP 2** Select a registered name to be input by either of the following methods:

- a. Press the talk switch and say a registered name.
- b. Press the talk switch and say “List Names”. Press the talk switch when the desired name is read aloud.

**STEP 3** Dial by one of the following methods:

- a. Press the off-hook switch.
- b. Press the talk switch and say “Dial”.

- c. Select “Dial” using .



### Speed dialing

**STEP 1** Press the off-hook switch.

**STEP 2** Press the preset button in which the desired number is registered.

**STEP 3** Press the off-hook switch.

### When receiving a phone call

**n Answering the phone**

Press the off-hook switch.

**n Refusing the call**

Press the on-hook switch.

### Transferring a call

A call can be transferred between the mobile phone and system while dialing, receiving a call, or during a call. Use one of the following methods:

a. Operate the mobile phone.

Refer to the manual that comes with the mobile phone for the operation of the phone.

b. Press the off-hook switch<sup>\*1</sup>.

c. Press the talk switch and say "Call Transfer"<sup>\*2</sup>.

<sup>\*1</sup>: This operation can be performed only when transferring a call from the mobile phone to the system during a call.

<sup>\*2</sup>: While the vehicle is in motion, calls cannot be transferred from the system to the mobile phone.

### Call waiting

When a call is interrupted by an incoming call from a third party, the following options will become available:

I Answer the incoming call: Press the off-hook switch. (Press the off-hook switch again as necessary to switch back and forth between calls.)

I Refuse the incoming call: Press the on-hook switch.

## Using the call history memory

Follow the procedure below to use a number stored in the call history memory:

**STEP 1** Press the talk switch and say “Redial” (when using a number stored in the outgoing call history memory) or “Call back” (when using a number stored in the incoming call history memory).

**STEP 2** Select the number by either of the following methods:

- Say “Previous” or “Go back” until the desired number is displayed.

- Select the desired number using  .

**STEP 3** The following operations can be performed:

Dialing: Press the off-hook switch or select “Dial” using a voice command or  .

Storing the number in the phone book: Select “Store” and then “Confirm” using a voice command or  .

Deleting: Select “Delete” and then “Confirm” using a voice command or  .

#### n **Call waiting**

- 1 If your phone does not support HFP Ver. 1.5, this function cannot be used.
- 1 Call waiting operation may differ depending on your mobile phone and service provider.

#### n **Call history**

Up to 5 numbers can be stored in each of the outgoing and incoming call history memories.

#### n **When talking on the phone**

- 1 Do not talk simultaneously with the other party.
- 1 Keep the volume of the received voice down. Otherwise, voice echo will increase.



## 3-4. Using the hands-free phone system (for mobile phones)

### Setting a mobile phone

Registering a mobile phone in the hands-free phone system allows the system to function. The following functions can be used for registered mobile phones:

#### n Functions and operation procedures

To enter the menu for each function, follow the steps below using a

voice command or



- 1 Registering a mobile phone
  1. "Setup" → 2. "Phone Setup" → 3. "Pair Phone"
- 1 Selecting a mobile phone to be used
  1. "Setup" → 2. "Phone Setup" → 3. "Connect Phone (Connect)"
- 1 Changing the registered name of a mobile phone
  1. "Setup" → 2. "Phone Setup" → 3. "Change Name"
- 1 Listing the registered mobile phones
  1. "Setup" → 2. "Phone Setup" → 3. "List Phones"
- 1 Changing the passkey
  1. "Setup" → 2. "Phone Setup" → 3. "Set Passkey"
- 1 Deleting a registered mobile phone
  1. "Setup" → 2. "Phone Setup" → 3. "Delete Phone"

## Registering a mobile phone

Select “Pair Phone” using a voice command or , and perform the procedure for registering a mobile phone. (→P. 369)

## Selecting a mobile phone to be used

**STEP 1** Select “Connect Phone (Connect)” using a voice command or



► Pattern A

**STEP 2** Select the mobile phone to be used by either of the following methods, and select “Confirm” by using a voice command or



- a. Press the talk switch and say the name of the desired mobile phone.
- b. Press the talk switch and say “List Phones”. When the name of the desired mobile phone is read aloud, press the talk switch.

► Pattern B

**STEP 2** Select the mobile phone to be used using



## Changing the registered name of a mobile phone

**STEP 1** Select “Change Name” using a voice command or  .

### ► Pattern A

**STEP 2** Select the name of the mobile phone to be changed by either of the following methods, and select “Confirm” using a voice com-

mand or  :

- Press the talk switch and say the name of the desired mobile phone.
- Press the talk switch and say “List Phones”. When the name of the desired mobile phone is read aloud, press the talk switch.

### ► Pattern B

**STEP 2** Select the desired mobile phone name to be changed using



**STEP 3** Press the talk switch or select “Record Name” using  , and say the new name.

**STEP 4** Select “Confirm” using a voice command or  .

### Listing the registered mobile phones

Select “List Phones” using a voice command or . The list of registered mobile phones will be read aloud.

When listing is complete, the system returns to “Phone Setup”.

Pressing the talk switch while the name of a mobile phone is being read aloud selects the mobile phone, and the following functions will become available:

- 1 Selecting a mobile phone: “Connect Phone (Connect)”
- 1 Changing a registered name: “Change Name”
- 1 Deleting a mobile phone: “Delete Phone”

### Changing the passkey

**STEP 1** Select “Set Passkey” using a voice command or .

► Pattern A

**STEP 2** Press the talk switch, say a 4 to 8-digit number, and select “Con-

firm” using a voice command or .

## ▶ Pattern B

**STEP 2** Select a 4 to 8-digit number using .

The number should be input 1 digit at a time.

**STEP 3** When the entire number to be registered as a passkey has been

input, press  again.

If the number to be registered has 8 digits, pressing of the knob is not necessary.

### Deleting a registered mobile phone

**STEP 1** Select “Delete Phone” using a voice command or .

## ▶ Pattern A

**STEP 2** Select the mobile phone to be deleted by either of the following

methods and select “Confirm” using a voice command or  :

- a. Press the talk switch and say the name of the desired mobile phone.
- b. Press the talk switch and say “List Phones”. When the name of the desired mobile phone is read aloud, press the talk switch.

► Pattern B

**STEP 2** Select the desired mobile phone to be deleted using  .

If the mobile phone to be deleted is paired as a Bluetooth<sup>®</sup> audio player, the registration of the audio player can be deleted at the same time. A voice guidance instruction to delete a Bluetooth<sup>®</sup> audio player is heard.

**STEP 3** Select “Yes” or “No” using a voice command or  .

(Bluetooth<sup>®</sup> audio player →P. 343)

---

**n The number of mobile phones that can be registered**

Up to 6 mobile phones can be registered in the system.

## Security and system setup

#### n Security setting items and operation procedures

To enter the menu for each function, follow the steps below using a

voice command or



- 1 Setting or changing the PIN (Personal Identification Number)
  1. "Setup" → 2. "Security" → 3. "Set PIN"
- 1 Locking the phone book
  1. "Setup" → 2. "Security" → 3. "Phonebook Lock (Phbk Lock)"
- 1 Unlocking the phone book
  1. "Setup" → 2. "Security" → 3. "Phonebook Unlock (Phbk Unlock)"

#### n System setup items and operation procedures

To enter the menu for each function, follow the steps below using





- 1 Setting voice guidance volume
  1. "Setup" → 2. "System Setup" → 3. "Guidance Vol"
- 1 Displaying the Bluetooth<sup>®</sup> device address and name
  1. "Setup" → 2. "System Setup" → 3. "Device Name"
- 1 Initializing the system
  1. "Setup" → 2. "System Setup" → 3. "Initialize"

## Setting or changing the PIN

### n Setting a PIN

**STEP 1** Select “Set PIN” using a voice command or  .

**STEP 2** Enter a PIN using a voice command or  .

When using  , input the code 1 digit at a time.

### n Changing the PIN

**STEP 1** Select “Set PIN” using a voice command or  .

**STEP 2** Enter the registered PIN using a voice command or  .

**STEP 3** Enter a new PIN using a voice command or  .

When using  , input the code 1 digit at a time.

## Locking or unlocking the phone book

**STEP 1** Select “Phonebook Lock (Phbk Lock)” or “Phonebook Unlock (Phbk Unlock)” using a voice command or  .



**STEP 2** Input the PIN by either of the following methods and select “Con-

firm” using a voice command or  :

a. Press the talk switch and say the registered PIN.

b. Input a new PIN using  .

### Setting voice guidance volume

**STEP 1** Select “Guidance Vol” using  .

**STEP 2** Change the voice guidance volume.

To decrease the volume: Turn  counterclockwise.

To increase the volume: Turn  clockwise.

### Displaying the Bluetooth® device address and name

**STEP 1** Select “Device Name” using  .

**STEP 2** Turn  to display the Bluetooth® device address and name.

**STEP 3** Select “Go Back” using  to return to “System Setup”.

## Initializing the system

**STEP 1** Select “Initialize” and then “Confirm” using



**STEP 2** Select “Confirm” again using



### n Initialization

1 The following data in the system can be initialized:

- Phone book
- Outgoing and incoming call history
- Speed dials
- Registered mobile phone data
- Security code
- Registered Bluetooth<sup>®</sup> enabled portable player data
- Passkey for the mobile phones
- Passkey for the Bluetooth<sup>®</sup> audio players
- Guidance volume
- Receiver volume
- Ring tone volume

1 Once the initialization has been completed, the data cannot be restored to its original state.

### n When the phone book is locked

The following functions cannot be used:

- 1 Dialing by inputting a name
- 1 Speed dialing
- 1 Dialing a number stored in the call history memory
- 1 Using the phone book

## Using the phone book

To enter the menu for each function, follow the steps below using a

voice command or



- 1 Adding a new phone number  
1. "Phonebook" → 2. "Add Entry"
- 1 Changing the registered name in the phone book  
1. "Phonebook" → 2. "Change Name"
- 1 Listing the registered data  
1. "Phonebook" → 2. "List Names"
- 1 Setting speed dials  
1. "Phonebook" → 2. "Set Speed Dial (Speed Dial)"
- 1 Deleting the registered data  
1. "Phonebook" → 2. "Delete Entry"
- 1 Deleting speed dials  
1. "Phonebook" → 2. "Delete Speed Dial (Del Spd Dial)"

### Adding a new phone number

The following methods can be used to add a new phone number:

- 1 Inputting a phone number using a voice command
- 1 Transferring data from the mobile phone

1 Inputting a phone number using



1 Selecting a phone number from outgoing or incoming call history

## n Adding procedure

**STEP 1** Select “Add Entry” using a voice command or  .

**STEP 2** Use one of the following methods to input a telephone number:  
Inputting a telephone number using a voice command:

STEP2-1 Select “By Voice” using a voice command or  .

STEP2-2 Press the talk switch, say the desired number, and select “Confirm” using a voice command.

Transferring data from the mobile phone:

STEP2-1 Select “By Phone” and then “Confirm” using a voice

command or  .

STEP2-2 Transfer the data from the mobile phone.

Refer to the manual that comes with the mobile phone for the details of transferring data.



STEP2-3 Select the data to be registered by either of the following methods:

a. Say “Previous” or “Next” until the desired data is displayed, and select “Confirm” using a voice command.

b. Select the desired data using  .

Inputting a phone number using  :

STEP2-1 Select “Manual Input” using  .

STEP2-2 Input a phone number using  , and press  again.

Input the phone number 1 digit at a time.

Selecting a phone number from outgoing or incoming call history:

STEP2-1 Select “Call History” using a voice command or  .

STEP2-2 Select “Outgoing” or “Incoming” using a voice command or  .

STEP2-3 Select the data to be registered by either of the following methods:

- a. Say “Previous” or “Go back” until the desired data is displayed, and select “Confirm” using a voice command.
- b. Select the desired data using  .

**STEP 3** Select the name to be registered by either of the following meth-

ods, and select “Confirm” using a voice command or  :

a. Press the talk switch and say the desired name.

b. Select “Record Name” using , and say the desired name.

**STEP 4** Select “Confirm” using a voice command or .

In **STEP 4**, selecting “Set Speed Dial (Speed Dial)” instead of “Confirm” registers the newly added phone number as a speed dial.

## Changing the registered name in the phone book

**STEP 1** Select “Change Name” using a voice command or .

### ► Pattern A

**STEP 2** Select the name to be changed by either of the following meth-

ods, and select “Confirm” using a voice command or  :

a. Press the talk switch, say the desired name.

b. Press the talk switch, and say “List Names”. When the desired name is read aloud, press the talk switch.

### ► Pattern B

**STEP 2** Select the desired name to be changed using .

**STEP 3** Press the talk switch or select “Record Name” using , and say the new name.

**STEP 4** Select “Confirm” using a voice command or .

### Listing the registered data

Select “List Names” using a voice command or . The list of the registered data will be read aloud.

When listing is complete, the system returns to the “Phonebook”.

Pressing the talk switch while the desired data is being read aloud selects the data, and the following function will become available:

- 1 Dialing: “Dial”
- 1 Changing a registered name: “Change Name”
- 1 Deleting an entry: “Delete Entry”
- 1 Setting a speed dial: “Set Speed Dial (Speed Dial)”

## Setting speed dials

**STEP 1** Select “Set Speed Dial (Speed Dial)” using a voice command or



► Pattern A

**STEP 2** Select the data to be registered as a speed dial by either of the following methods, and select “Confirm” using a voice command



or :

- Press the talk switch, say the desired name.
- Press the talk switch, and say “List Names”. When the desired name is read aloud, press the talk switch.

► Pattern B

**STEP 2** Select the desired data using



**STEP 3** Select the desired preset button, and register the data into speed dial by either of the following methods:

- Press the desired preset button, and select “Confirm” by using

a voice command or



- Press and hold the desired preset button.



## Deleting the registered data

**STEP 1** Select “Delete Entry” using a voice command or



► Pattern A

**STEP 2** Select the data to be deleted by either of the following methods,

and select “Confirm” using a voice command or



a. Press the talk switch, and say the name of the desired phone number.

b. Press the talk switch, say “List Names”. When the name of the desired phone number is read aloud, press the talk switch.

► Pattern B

**STEP 2** Select the desired data to be deleted using



## Deleting speed dials

**STEP 1** Select “Delete Speed Dial (Del Spd Dial)” using a voice command or



**STEP 2** Press the preset button to which the desired speed dial is registered, and select “Confirm” using a voice command or



### n Limitation of number of digits

A phone number that exceeds 24 digits cannot be registered.

### 3-5. Using the interior lights

## Interior lights list

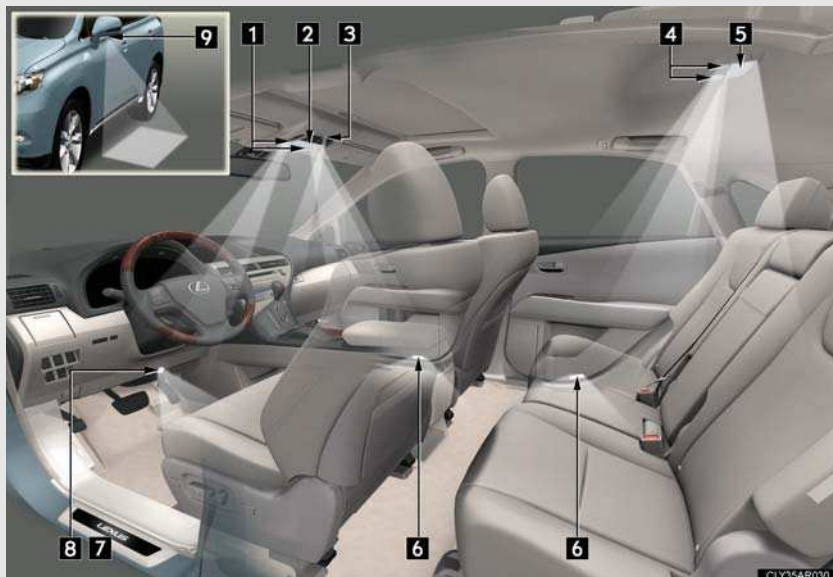

- 1 Front personal lights (→P. 397)
- 2 Front interior lights (→P. 397)
- 3 Shift lever light (when the “ENGINE START STOP” switch is in ACCESSORY or IGNITION ON mode)
- 4 Rear personal lights (→ P. 397)
- 5 Rear interior light
- 6 Door courtesy lights
- 7 Scuff lights (if equipped)
- 8 Footwell lights
- 9 Outer foot lights

## Interior lights

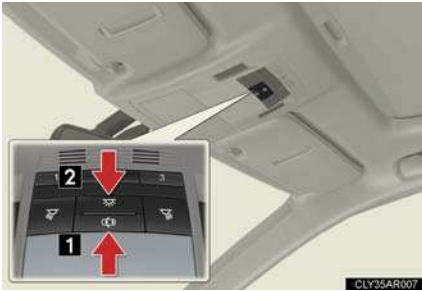

- 1 Turns the lights on/off linked to the door positions
- 2 Turns the lights on/off

## Personal lights

### ► Front

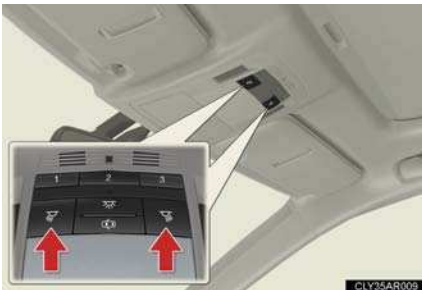

Turns the light on/off

### ► Rear

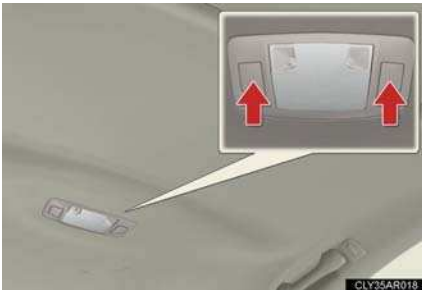

Turns the light on/off

---

**n Illuminated entry system**

The lights automatically turn on/off according to “ENGINE START STOP” switch mode, the presence of the electronic key, whether the doors are locked/unlocked, and whether the doors are open/closed.

**n To prevent battery discharge**

If the interior lights remain on when the door is not fully closed and the interior light switch (door position on/ off) is on, the lights will go off automatically after 20 minutes.

**n Customization**

Settings (e.g. the time elapsed before the lights turn off) can be changed. (Customizable features →P. 621)

## 3-6. Using the storage features

### List of storage features

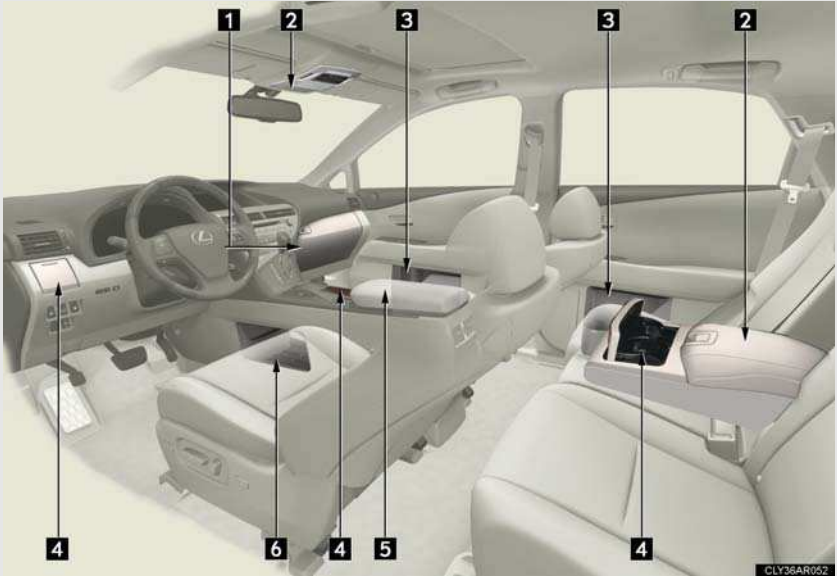

- 1 Glove box
- 2 Auxiliary boxes (if equipped)
- 3 Bottle holders/door pockets
- 4 Cup holders
- 5 Console box
- 6 Under tray

#### CAUTION

##### **n** Items that should not be left in the storage spaces

Do not leave glasses, lighters or spray cans in the storage spaces, as this may cause the following when cabin temperature becomes high:

- 1 Glasses may be deformed by heat or cracked if they come into contact with other stored items.
- 1 Lighters or spray cans may explode. If they come into contact with other stored items, the lighter may catch fire or the spray can may release gas, causing a fire hazard.

## Glove box

The glove box can be opened by pressing the lock release button and locked and unlocked using the mechanical key.



- 1 Opens
- 2 Locks
- 3 Unlocks

### n Power back door main switch (if equipped)

The power back door main switch is located in the glove box. (→P. 52)

## ⚠ CAUTION

### n Caution while driving

Keep the glove box closed.

Injuries may result in the event of an accident or sudden braking.

## Bottle holders/door pockets

### ► Front



The front door pockets can be opened and closed.

### ► Rear



## ! CAUTION

### n Caution while driving (front door pockets)

Keep the door pockets closed.

Injuries may result in the event of an accident or sudden braking.

### n Items unsuitable for the bottle holders

Do not place anything other than bottle in the bottle holders.

Other items may be thrown out of the holders in the event of an accident or sudden braking and cause injury.

 NOTICE**■ When stowing a bottle**

Put the cap on before stowing the bottle. Do not place open bottles in the bottle holders. The contents may spill.

**Cup holders****► Front (type A)**

Press down and release the right side of the cup holder lid.

**► Front (type B)**

Press in and release the cup holder.



## ► Rear

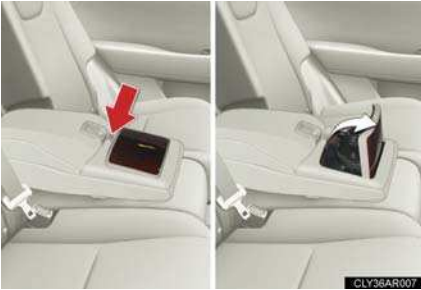

Press down the button on the armrest.

## n Cup holder insert



Cup holder insert may be removed for cleaning.

 **CAUTION**
n **Items unsuitable for the cup holder**

Do not place anything other than cups or beverage cans in the cup holders. Even when the lid is closed, items must not be stored in the cup holders. Other items may be thrown out of the holders in the event of an accident or sudden braking and cause injury.

n **To prevent burns**

Put a lid on containers with hot liquids inside.

n **When not in use**

Keep the cup holders closed.

Injuries may result in the event of an accident or sudden braking.

## Console box

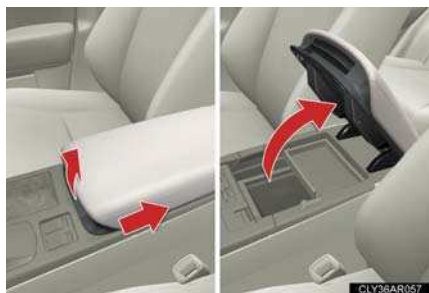

Slide the armrest while pulling up the lever, and lift the armrest.

### Trays in the console box

#### ► Upper tray/upper trays

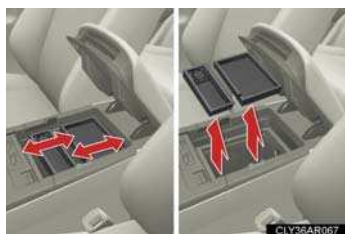

The trays slide forward/backward and can be removed.

#### ► Lower tray



The tray can be removed.

 **CAUTION****n Caution while driving**

Keep the console box closed.

Injuries may result in the event of an accident or sudden braking.

 **NOTICE****n Tray**

Do not insert items exceeding the height of the tray. Doing so may prevent opening and closing of the lid.

**Auxiliary boxes (if equipped)**

► Overhead



Press in the lid.

This box is useful for temporarily storing sunglasses and similar small items.

► Rear seat



Pull down the armrest.



Pull up the lever to release the lock and lift the armrest.

**! CAUTION****n Caution while driving**

Do not leave the auxiliary box open while driving. Items may fall out and cause death or serious injury in case of an accident or sudden stop.

**Under tray****! CAUTION****n Items unsuitable for the under tray**

Observe the following precautions when putting items in the under tray. Failure to do so may cause items to be thrown out of the tray in the event of sudden braking or steering. In these cases, the items may interfere with pedal operation or cause driver distraction, resulting in an accident.

- I** Do not store items in the tray that can easily shift or roll out.
- I** Do not stack items in the tray higher than the tray's edge.
- I** Do not put items in the tray that may protrude over the tray's edge.

### 3-7. Other interior features

## Sun visors

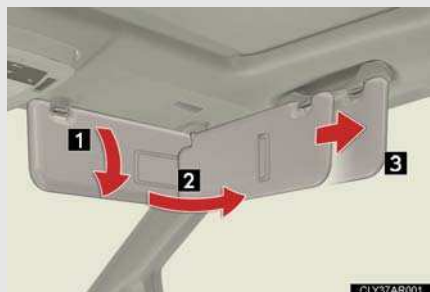

- 1 To set the visor in the forward position, flip down.
- 2 To set the visor in the side position, flip down it, unhook, and swing to the side.
- 3 To use the side extender, place the visor in the side position, then slide backward.

### 3-7. Other interior features

## Vanity mirrors

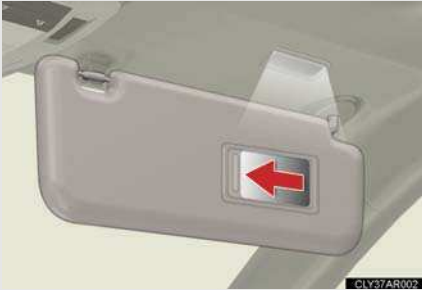

Slide the cover to open.

The light turns on when the cover is opened.

#### NOTICE

##### **n To prevent battery discharge**

Do not leave the vanity lights on for extended periods while the engine is stopped.

## 3-7. Other interior features

### Clock

The clock is displayed when the “ENGINE START STOP” switch is in ACCESSORY or IGNITION ON mode. Perform the following steps to adjust the clock.

▶ Without navigation system



- 1 Adjusts the hours
- 2 Adjusts the minutes

▶ With navigation system

Refer to “Navigation System Owner’s Manual”.

---

n **When the battery is disconnected**

The time display will automatically be set to 1:00.



### 3-7. Other interior features

## Outside temperature display

The temperature display shows within the range of -40°F (-40°C) and 122°F (50°C).

- ▶ Without navigation system



- ▶ With navigation system  
Refer to “Navigation System Owner’s Manual”.

#### n If the temperature does not appear

The system may be malfunctioning. Take your vehicle to your Lexus dealer.

#### n Display

In the following situations, the correct outside temperature may not be displayed, or the display may take longer than normal to change:

- 1 When the vehicle is stopped, or moving at low speeds (less than 16 mph [25 km/h])
- 1 When the outside temperature has changed suddenly (at the entrance/exit of a garage, tunnel, etc.)

### 3-7. Other interior features

## Multi-display light control (vehicles without a navigation system)

The brightness of the multi-display can be adjusted to four levels.



Press and release the “DISP” switch until the brightness of the display is adjusted to the desired level.

#### ■ Instrument panel linked brightness control

When the headlight switch is turned on, the brightness of the multi-display will be reduced in accordance with the brightness of the instrument panel. (→P. 167)

## 3-7. Other interior features

### Power outlets

The power outlets can be used for a following component:

12 V: Accessories that run on less than 10 A.

120 VAC: Accessories that use less than 100 W.

#### ► Inside the console (12 V)

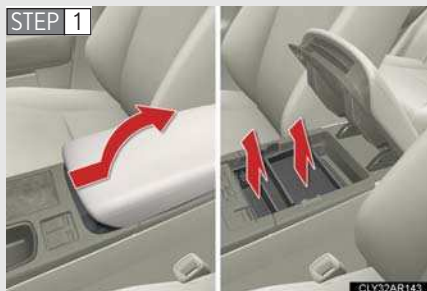

Slide the armrest while pulling up the lever, and lift the armrest. Remove the upper trays (if equipped).

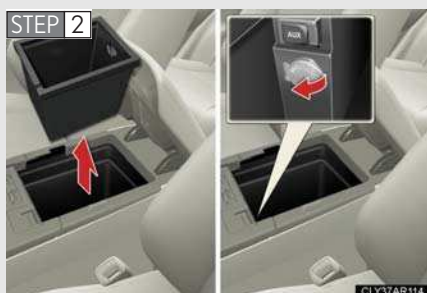

Remove the lower tray.

#### ► Under tray (12 V)



### 3-7. Other interior features

#### ▶ Luggage compartment (12 V)



#### ▶ On the back surface of the console (120 VAC\*)



\*: If equipped

### n Routing accessory device cables



When the cover is slide open, accessory device cables can be pulled through the opening.

### n The power outlets can be used when

12 V

The “ENGINE START STOP” switch is in ACCESSORY or IGNITION ON mode.

120 VAC

The “ENGINE START STOP” switch is in IGNITION ON mode.

### ⚠ NOTICE

#### n To avoid damaging the power outlets

Close the power outlet lid when the power outlet is not in use.

Foreign objects or liquids that enter the power outlet may cause a short circuit.

#### n To prevent the fuse from being blown

12 V: Do not use an accessory that uses more than 12 V 10 A.

120 VAC: Do not use a 120 VAC appliance that requires more than 100 W.

If a 120 VAC appliance that consumes more than 100 W is used, the protection circuit will cut the power supply.

#### n To prevent battery discharge

Do not use the power outlets longer than necessary when the engine is not running.

#### n Appliances that may not operate properly (120 VAC)

The following 120 VAC appliances may not operate properly even if their power consumption is under 100 W:

- l Appliances with high initial peak wattage
- l Measuring devices that process precise data
- l Other appliances that require an extremely stable power supply

## 3-7. Other interior features

### Seat heaters and ventilators\*

The seat heaters and ventilators heat the seats and maintain good airflow by blowing air from the seats.

#### n Seat heaters

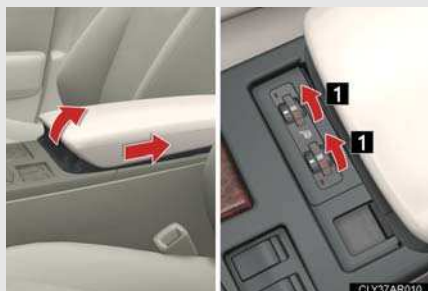

- 1 Turns the seat heater on  
The indicator light comes on.  
The higher the number is, the warmer the seat becomes.

#### n Seat heaters/ventilators



- 1 Turns the seat heater on  
The indicator light comes on.  
The higher the number is, the warmer the seat becomes.
- 2 Blows air from the seat  
The indicator light comes on.  
The higher the number is, the stronger the airflow becomes.

#### n Operating condition

The "ENGINE START STOP" switch is in IGNITION ON mode.

#### n When not in use

Set the knob at "0". The indicator light turns off.

\*: If equipped

 **CAUTION****n Burns**

- I** Use caution when seating the following persons in a seat with the seat heater on to avoid the possibility of burns:
- Babies, small children, the elderly, the sick and the physically challenged
  - Persons with sensitive skin
  - Persons who are fatigued
  - Persons who have taken alcohol or drugs that induce sleep (sleeping drugs, cold remedies, etc.)
- I** Do not cover the seat with anything when using the seat heater. Using the seat heater with a blanket or cushion increases the temperature of the seat and may lead to overheating.

 **NOTICE****n To prevent damage to the seat heaters/ventilators**

Do not put heavy objects that have an uneven surface on the seat and do not stick sharp objects (needles, nails, etc.) into the seat.

**n To prevent battery discharge**

Do not leave the system on longer than necessary when the engine is off.

### 3-7. Other interior features

## Armrest



Pull the armrest down for use.

#### NOTICE

**n To prevent damage to the armrest**

Do not place too much strain on the armrest.



### 3-7. Other interior features

## Coat hooks

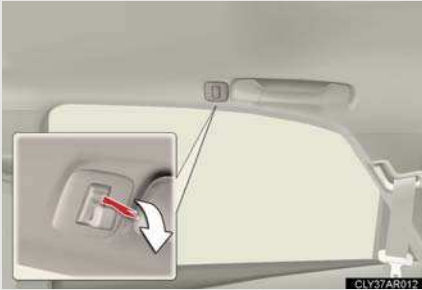

To use the coat hook, push it in.

### CAUTION

#### **n** Items that must not be hung on the hook

Do not hang a coat hanger or other hard or sharp object on the hook. If the SRS curtain shield airbags deploy, these items may become projectiles that cause death or serious injury.

## 3-7. Other interior features

### Floor mat

Use only floor mats designed specifically for vehicles of the same model and model year as your vehicle. Fix them securely in place onto the carpet.

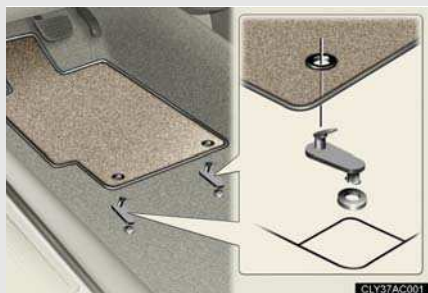

Fix the floor mat in place using the retaining hooks (clips) provided.

The shape of the retaining hooks (clips) and the fixing procedure of the floor mat for your vehicle may differ from those shown in the illustration. For details, refer to the floor mat retention clip installation instructions supplied with the clips.

#### CAUTION

Observe the following precautions.

Failure to do so may cause the driver's floor mat to slip, possibly interfering with the pedals while driving. An unexpectedly high speed may result or it may become difficult to stop the vehicle, leading to a serious accident.

#### **n** When installing the driver's floor mat

- 1 Do not use floor mats designed for other models or different model year vehicles, even if they are Lexus Genuine floor mats.
- 1 Only use floor mats designed for the driver's seat.
- 1 Always install the floor mat securely using the retaining hooks (clips) provided.
- 1 Do not use two or more floor mats on top of each other.
- 1 Do not place the floor mat bottom-side up or upside-down.

#### **n** Before driving



- 1 Check that the floor mat is securely fixed in the right place with all the provided retaining hooks (clips). Be especially careful to perform this check after cleaning the floor.
- 1 With the engine stopped and the shift lever in P, fully depress each pedal to the floor to make sure it does not interfere with the floor mat.

## 3-7. Other interior features

# Luggage compartment features

### n Cargo hooks



Pull the hook to use.

The cargo hooks are provided for securing loose items.

### n Auxiliary boxes

#### ► Type A



Pull the lever upwards when lifting the deck board up.

► Type B

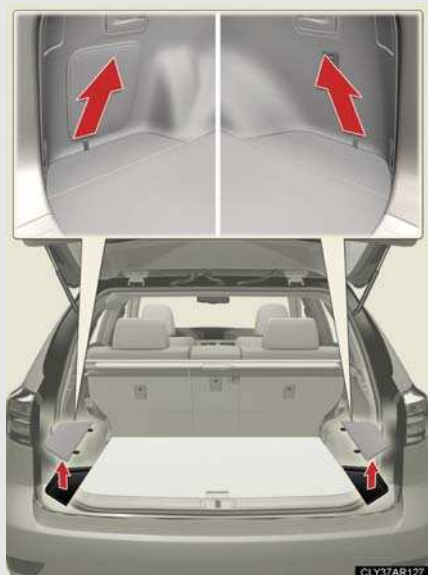

Pull the strap upwards when lifting the cover up.

## n Luggage cover

STEP 1

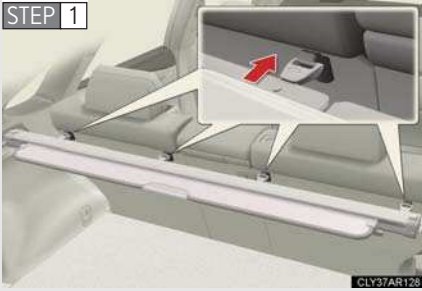

Attach the hooks to the hook brackets on the rear seat seat-back.

STEP 2

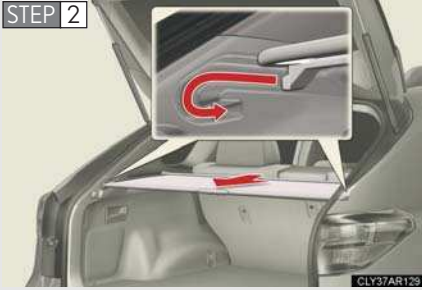

Pull out the luggage cover and hook it onto the anchors.

## Removing the luggage covers

### ► Front luggage cover

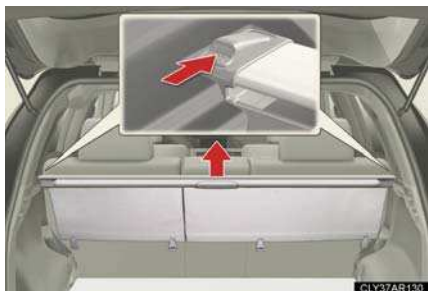

Press the buttons to remove the luggage cover.

### ► Rear luggage cover



Detach the outer clips of the rear luggage cover from the back door.

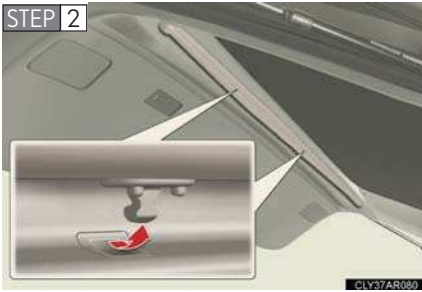

Detach the inner clips of the rear luggage cover from the back door.

#### n Installing the rear luggage cover

- 1 Ensure that the luggage cover is in the proper installation position. Push the clips of the rear luggage cover into the indentions on the back door until they are locked into place.
- 1 Check that the rear luggage cover is securely attached.

#### **!** CAUTION

##### n When the cargo hooks are not in use

To avoid injury, always return the cargo hooks to their stowed positions.

## 3-7. Other interior features

# Garage door opener

The garage door opener can be programmed to operate garage doors, gates, entry doors, door locks, home lighting systems, security systems, and other devices.

The garage door opener (HomeLink<sup>®</sup> Universal Transceiver) is manufactured under license from HomeLink<sup>®</sup>.

### Programming the HomeLink<sup>®</sup> (for U.S.A. owners)

The HomeLink<sup>®</sup> compatible transceiver in your vehicle has 3 buttons which can be programmed to operate 3 different devices. Refer to the programming method below appropriate for the device.

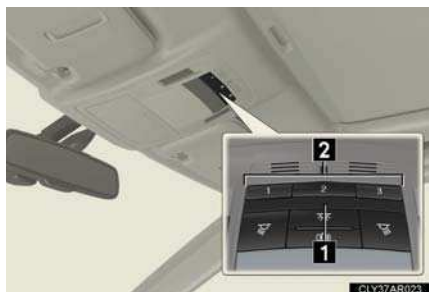

1 Indicator

2 Buttons

#### n Programming the HomeLink<sup>®</sup>



Point the remote control transmitter for the device 1 to 3 in. (25 to 75 mm) from the HomeLink<sup>®</sup> control buttons.

Keep the HomeLink<sup>®</sup> indicator light in view while programming.



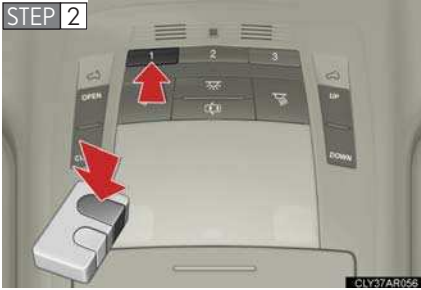

Press and hold one of the HomeLink<sup>®</sup> buttons and the transmitter button. When the HomeLink<sup>®</sup> indicator light changes from a slow to a rapid flash, you can release both buttons.

If the HomeLink<sup>®</sup> indicator light comes on but does not flash, or flashes rapidly for 2 seconds and remains lit, the HomeLink<sup>®</sup> button is already programmed. Use the other buttons or follow the “Reprogramming a HomeLink<sup>®</sup> button” instructions. (→P. 429)



Test the HomeLink<sup>®</sup> operation by pressing the newly programmed button.

If a HomeLink<sup>®</sup> button has been programmed for a garage door, check to see if the garage door opens and closes. If the garage door does not operate, see if your remote control transmitter is of the rolling code type. Press and hold the programmed HomeLink<sup>®</sup> button. The remote control transmitter is of the rolling code type if the HomeLink<sup>®</sup> indicator light flashes rapidly for 2 seconds and then remains lit. If your transmitter is of the rolling code type, proceed to the heading “Programming a rolling code system”.

**STEP 4** Repeat the steps above to program another device for each of the remaining HomeLink<sup>®</sup> buttons.

### n **Programming a Rolling Code system (for U.S.A. owners)**

If your device is Rolling Code equipped, follow the steps under the heading “Programming the HomeLink<sup>®</sup>” before proceeding with the steps listed below.

**STEP 1** Locate the learn button on the ceiling mounted garage door opener motor. The exact location and color of the button may vary by brand of garage door opener motor.

Refer to the operation manual supplied with the garage door opener for the location of the learn button.

**STEP 2** Press the learn button.

Following this step, you have 30 seconds in which to initiate step 3 below.

**STEP 3** Press and hold the vehicle’s programmed HomeLink<sup>®</sup> button for 2 seconds and release it. Repeat this step once again. The garage door may open.

If the garage door opens, the programming process is complete. If the door does not open, press and release the button a third time. This third press and release will complete the programming process by opening the garage door.

The ceiling mounted garage door opener motor should now recognize the HomeLink<sup>®</sup> signal and operate the garage door.

**STEP 4** Repeat the steps above to program another rolling code system for any of the remaining HomeLink<sup>®</sup> buttons.

### n **Programming an entry gate (for U.S.A. owners)/Programming all devices in the Canadian market**

**STEP 1** Place your transmitter 1 to 3 in. (25 to 75 mm) away from the surface of the HomeLink<sup>®</sup>.

Keep the HomeLink<sup>®</sup> indicator light in view while programming.

**STEP 2** Press and hold the selected HomeLink<sup>®</sup> button.

**STEP 3** Repeatedly press and release (cycle) the device’s remote control button for two seconds each until step 4 is completed.

**STEP 4** When the indicator light on the HomeLink<sup>®</sup> compatible transceiver starts to flash rapidly, release the buttons.

**STEP 5** Test the operation of the HomeLink<sup>®</sup> by pressing the newly programmed button. Check to see if the gate/device operates correctly.

**STEP 6** Repeat the steps above to program another device for each of the remaining HomeLink<sup>®</sup> buttons.

#### **n Programming other devices**

To program other devices such as home security systems, home door locks or lighting, contact your authorized Lexus dealer for assistance.

#### **n Reprogramming a button**

The individual HomeLink<sup>®</sup> buttons cannot be erased but can be reprogrammed. To reprogram a button, follow the “Reprogramming a HomeLink<sup>®</sup> button” instructions.

### **Operating HomeLink<sup>®</sup>**

Press the appropriate HomeLink<sup>®</sup> button. The HomeLink<sup>®</sup> indicator light should turn on.

The HomeLink<sup>®</sup> compatible transceiver in your vehicle continues to send a signal for up to 20 seconds as long as the button is pressed.

### **Reprogramming a HomeLink<sup>®</sup> button**

Press and hold the desired HomeLink<sup>®</sup> button. After 20 seconds, the HomeLink<sup>®</sup> indicator light will start flashing slowly. Next, while still pressing and holding the HomeLink<sup>®</sup> button, press and hold the button on the transmitter until the HomeLink<sup>®</sup> indicator light changes from a slow to a rapid flash.

## Erasing the entire HomeLink® memory (all three programs)



Press and hold the 2 outside buttons for 10 seconds until the indicator light flashes.

If you sell your vehicle, be sure to erase the programs stored in the HomeLink® memory.

### ■ Before programming

- 1 Install a new battery in the remote control transmitter.
- 1 The battery side of the remote control transmitter must be pointed away from the HomeLink® button.

### ■ Certification for the garage door opener

- For vehicles sold in the U.S.A.

FCC ID: CB2070NHL4

#### NOTE:

This device complies with Part 15 of the FCC Rules. Operation is subject to the following two conditions: (1) this device may not cause harmful interference, and (2) this device must accept any interference received, including interference that may cause undesired operation.

#### FCC WARNING:

Changes or modifications not expressly approved by the party responsible for compliance could void the user's authority to operate the equipment.

- For vehicles sold in Canada

#### NOTE:

Operation is subject to the following two conditions: (1) this device may not cause interference, and (2) this device must accept any interference, including interference that may cause undesired operation of the device.

### ■ When support is necessary

Visit on the web at [www.homelink.com](http://www.homelink.com) or call 1-800-355-3515.

 **CAUTION****n When programming a garage door or other remote control device**

The garage door or other device may operate, so ensure people and objects are out of danger to prevent potential harm.

**n Conforming to federal safety standards**

Do not use the HomeLink<sup>®</sup> compatible transceiver with any garage door opener or device that lacks safety stop and reverse features as required by federal safety standards.

This includes any garage door that cannot detect an obstruction object. A door or device without these features increases the risk of death or serious injury.

### 3-7. Other interior features

## Compass\*

The compass on the inside rear view mirror indicates the direction in which the vehicle is heading.

#### n Operation

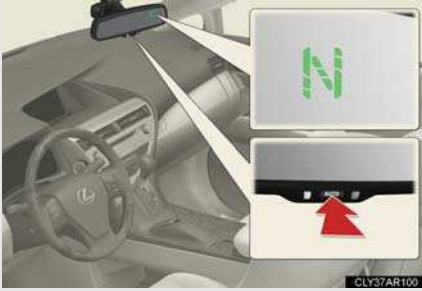

To turn the compass on or off, press "AUTO" for more than 3 seconds.

#### n Displays and directions

Display	Direction
"N"	North
"NE"	Northeast
"E"	East
"SE"	Southeast
"S"	South
"SW"	Southwest
"W"	West
"NW"	Northwest

\*: If equipped

## Calibrating the compass

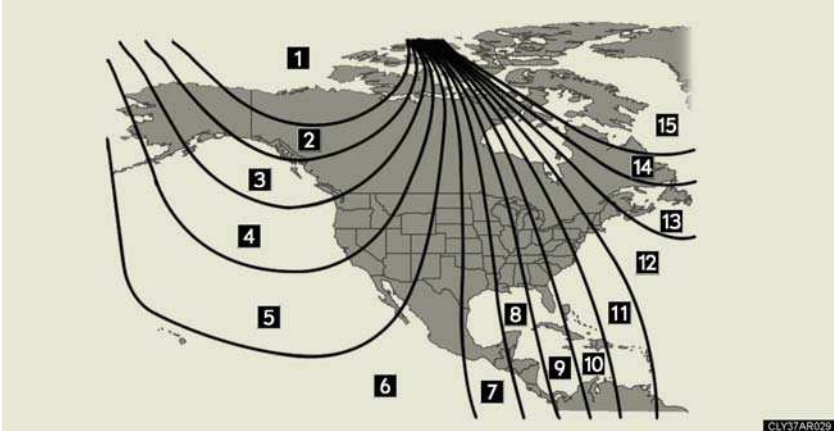

The direction display deviates from the true direction determined by the earth's magnetic field. The amount of deviation varies depending on the geographic position of the vehicle.

If you cross over one of the map boundaries shown in illustration, the compass will deviate.

To obtain higher precision or perfect calibration, refer to "Deviation calibration".

### n Deviation calibration

**STEP 1** Stop the vehicle.

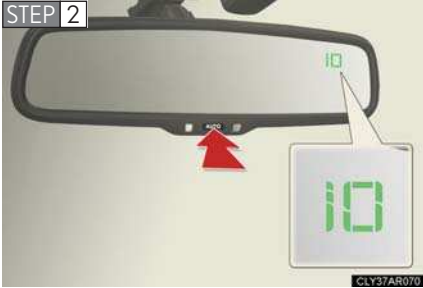

Press and hold "AUTO".

A number (1 to 15) appears on the compass display.

**STEP 3** Referring to the map above, press "AUTO" to select the number of the zone where you are in.

If the direction is displayed for several seconds after adjustment, the calibration is complete.

### n Circling calibration



If "C" appears on the display, drive the vehicle at 5 mph (8 km/h) or less in a circle until a direction is displayed.

If there is not enough space to drive in a circle, drive around the block until a direction is displayed.



**n Conditions unfavorable to correct operation**

The compass may not show the correct direction in the following conditions:

- 1 The vehicle is stopped immediately after turning.
- 1 The vehicle is on an inclined surface.
- 1 The vehicle is in a place where the earth's magnetic field is subject to interference by artificial magnetic fields (underground car park/parking lot, under a steel tower, between buildings, roof car park/parking lot, near an intersection, near a large vehicle, etc.).
- 1 The vehicle has become magnetized. (There is a magnet or metal object near the inside rear view mirror.)
- 1 The battery has been disconnected.
- 1 A door is open.

**! CAUTION****n While driving the vehicle**

Do not adjust the display. Adjust the display only when the vehicle is stopped.

**n When doing the circling calibration**

Secure a wide space, and watch out for people and vehicles in the vicinity. Do not violate any local traffic rules while performing circling calibration.

**! NOTICE****n To avoid compass malfunctions**

Do not place magnets or any metal objects near the inside rear view mirror. Doing this may cause the compass sensor malfunction.

**n To ensure normal operation of the compass**

- 1 Do not perform a circling calibration of the compass in a place where the earth's magnetic field is subject to interference by artificial magnetic fields.
- 1 During calibration, do not operate electric systems (moon roof, power windows, etc.) as they may interfere with the calibration.

### 3-7. Other interior features

## Safety Connect\*

Safety Connect is a subscription-based telematics service that uses Global Positioning System (GPS) data and embedded cellular technology to provide safety and security features to subscribers. Safety Connect is supported by Lexus' designated response center, which operates 24 hours per day, 7 days per week.

Safety Connect service is available by subscription on select, telematics hardware-equipped vehicles.

By using the Safety Connect service, you are agreeing to be bound by the Telematics Subscription Service Agreement and its Terms and Conditions, as in effect and amended from time to time, a current copy of which is available at Lexus.com. All use of the Safety Connect service is subject to such then-applicable Terms and Conditions.

#### n System components

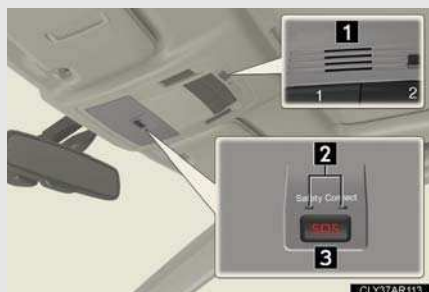

- 1 Microphone
- 2 LED light indicators
- 3 "SOS" button

**n Services**

Subscribers have the following Safety Connect services available:

**1 Automatic Collision Notification\***

Helps drivers receive necessary response from emergency service providers. (→P. 439)

\*: U.S. Patent No. 7,508,298 B2

**1 Stolen Vehicle Location**

Helps drivers in the event of vehicle theft. (→P. 440)

**1 Emergency Assistance Button (SOS)**

Connects drivers to response-center support. (→P. 440)

**1 Roadside Assistance**

Provides drivers various on-road assistance. (→P. 440)

**n Subscription**

After you have signed the Telematics Subscription Service Agreement and are enrolled, you can begin receiving services.

A variety of subscription terms is available for purchase. Contact your Lexus dealer, call 1-800-25-LEXUS (1-800-255-3987) or push the “SOS” button in your vehicle for further subscription details.

### **n Safety Connect Services Information**

- l Phone calls using the vehicles Bluetooth® technology will not be possible during Safety Connect.
- l Safety Connect is available beginning Fall 2009 on select Lexus models. Contact with the Safety Connect response center is dependent upon the telematics device being in operative condition, cellular connection availability, and GPS satellite signal reception, which can limit the ability to reach the response center or receive emergency service support. Enrollment and Telematics Subscription Service Agreement required. A variety of subscription terms is available; charges vary by subscription term selected.
- l All vehicles sold in the United States (except Hawaii) are equipped with Safety Connect. The Safety Connect services will function in the United States (except Hawaii) but will not function in Canada. For details about the service, contact your Lexus dealer.
- l Safety Connect services are not subject to section 255 of the Telecommunications Act and the device is not TTY compatible.

### **n Languages**

The Safety Connect response center will offer support in multiple languages. The Safety Connect system will offer voice prompts in English and Spanish. Please indicate your language of choice when enrolling.

### **n When contacting the response center**

You may be unable to contact the response center if the network is busy.

### Safety Connect LED light Indicators

When the “ENGINE START STOP” switch is turned to IGNITION ON mode, the red indicator light comes on for 2 seconds then turns off. Afterward, the green indicator light comes on, indicating that the service is active.

The following indicator light patterns indicate specific system usage conditions:

- 1 Green indicator light on = Active service
- 1 Green indicator light flashing = Safety Connect call in process
- 1 Red indicator light (except at vehicle start-up) = System malfunction (contact your Lexus dealer)
- 1 No indicator light (off) = Safety Connect service not active

### Safety Connect services

#### n Automatic Collision Notification

In case of either airbag deployment or severe rear-end collision, the system is designed to automatically call the response center. The responding agent receives the vehicle’s location and attempts to speak with the vehicle occupants to assess the level of emergency. If the occupants are unable to communicate, the agent automatically treats the call as an emergency, contacts the nearest emergency services provider to describe the situation, and requests that assistance be sent to the location.

### n **Stolen Vehicle Location**

If your vehicle is stolen, Safety Connect can work with local authorities to assist them in locating and recovering the vehicle. After filing a police report, call the Safety Connect response center at 1-800-25-LEXUS (1-800-255-3987) and follow the prompts for Safety Connect to initiate this service.

In addition to assisting law enforcement with recovery of a stolen vehicle, Safety-Connect-equipped vehicle location data may, under certain circumstances, be shared with third parties to locate your vehicle. Further information is available at [Lexus.com](http://Lexus.com).

### n **Emergency Assistance Button (“SOS”)**

In the event of an emergency on the road, push the “SOS” button to reach the Safety Connect response center. The answering agent will determine your vehicle’s location, assess the emergency, and dispatch the necessary assistance required.

If you accidentally press the “SOS” button, tell the response-center agent that you are not experiencing an emergency.

### n **Roadside Assistance**

Subscribers can press the “SOS” button to reach a Safety Connect response-center agent, who can help with a wide range of needs, such as: towing, flat tire, fuel delivery, etc. For a description of the Roadside Assistance services and their limitations, please see the Safety Connect Terms and Conditions, which are available at [Lexus.com](http://Lexus.com).

## Safety information for Safety Connect

Important! Read this information before using Safety Connect.

### n Exposure to radio frequency signals

The Safety Connect system installed in your vehicle is a low-power radio transmitter and receiver. It receives and also sends out radio frequency (RF) signals.

In August 1996, the Federal Communications Commission (FCC) adopted RF exposure guidelines with safety levels for mobile wireless phones. Those guidelines are consistent with the safety standards previously set by the following U.S. and international standards bodies.

- 1 ANSI (American National Standards Institute) C95.1 [1992]
- 1 NCRP (National Council on Radiation Protection and Measurement) Report 86 [1986]
- 1 ICNIRP (International Commission on Non-Ionizing Radiation Protection) [1996]

Those standards were based on comprehensive and periodic evaluations of the relevant scientific literature. Over 120 scientists, engineers, and physicians from universities, and government health agencies and industries reviewed the available body of research to develop the ANSI Standard (C95.1).

The design of Safety Connect complies with the FCC guidelines in addition to those standards.

**n License**

Licensed by QUALCOMM Incorporated under one or more of the following United States Patents and/or their counterparts in other nations:

4,901,307 5,490,165 5,056,109 5,504,773 5,101,501  
5,506,865 5,109,390 5,511,073 5,228,054 5,535,239  
5,267,261 5,544,196 5,267,262 5,568,483 5,337,338  
5,600,754 5,414,796 5,657,420 5,416,797 5,659,569  
5,710,784 5,778,338





## 4-1. Maintenance and care

# Cleaning and protecting the vehicle exterior

**Perform the following to protect the vehicle and maintain it in prime condition:**

- 1 Working from top to bottom, liberally apply water to the vehicle body, wheel wells and underside of the vehicle to remove any dirt and dust.
- 1 Wash the vehicle body using a sponge or soft cloth, such as a chamois.
- 1 For hard-to-remove marks, use car wash soap and rinse thoroughly with water.
- 1 Wipe away any water.
- 1 Wax the vehicle when the waterproof coating deteriorates.

If water does not bead on a clean surface, apply wax when the vehicle body is cool.

---

### n Automatic car washes

- 1 Before washing the vehicle:
  - Fold the mirrors.
  - Turn off the power back door system (if equipped).
- 1 Brushes used in automatic car washes may scratch the vehicle surface and harm your vehicle's paint.

### n High pressure car washes

- 1 Do not allow the nozzles of the car wash to come within close proximity of the windows.
- 1 Before using the car wash, check that the fuel filler door on your vehicle is closed properly.

### n Aluminum wheels

- 1 Remove any dirt immediately by using a neutral detergent. Do not use hard brushes or abrasive cleaners. Do not use strong or harsh chemical cleaners. Use the same mild detergent and wax as used on the paint.
- 1 Do not use detergent on the wheels when they are hot, for example after driving for long distance in the hot weather.
- 1 Wash detergent from the wheels immediately after use.

### n Bumpers

Do not scrub with abrasive cleaners.

### n To prevent deterioration and body corrosion

- 1 Wash the vehicle immediately in the following cases:
  - After driving near the sea coast
  - After driving on salted roads
  - If you see coal tar or tree sap on the paint surface
  - If dead insects, insect droppings or bird droppings are present on the paint surface
  - After driving in an area contaminated with soot, oily smoke, mine dust, iron powder or chemical substances
  - If the vehicle becomes heavily soiled in dust or mud
  - If liquids such as benzene and gasoline are spilled on the paint surface
- 1 If the paint is chipped or scratched, have it repaired immediately.

### CAUTION

#### n Precautions regarding the exhaust pipe

Exhaust gases cause the exhaust pipe to become quite hot.

When washing the vehicle, be careful not to touch the pipe until it has cooled sufficiently, as touching a hot exhaust pipe can cause burns.

### NOTICE

#### **n To prevent paint deterioration and corrosion on the body and components (aluminum wheels etc.)**

**l** Wash the vehicle immediately in the following cases:

- After driving near the sea coast
- After driving on salted roads
- If you see coal tar or tree sap on the paint surface
- If you see dead insects, insect droppings or bird droppings on the paint
- After driving in an area contaminated with soot, oily smoke, mine dust, iron powder or chemical substances
- If the vehicle becomes heavily soiled in dust or mud
- If liquids such as benzene and gasoline are spilled on the paint surface

**l** If the paint is chipped or scratched, have it repaired immediately.

**l** To prevent the wheels from corroding, remove any dirt and store in a place with low humidity when storing the wheels.

#### **n Cleaning the exterior lights**

**l** Wash carefully. Do not use organic substances or scrub with a hard brush. This may damage the surfaces of the lights.

**l** Do not apply wax to the surfaces of the lights. Wax may cause damage to the lenses.

#### **n To prevent damage to the windshield wiper arms**

When lifting the wiper arms away from the windshield, pull the driver side wiper arm upward first, and repeat for the passenger side. When returning the wipers to their original position, do so from the passenger side first.

#### **n When using an automatic car wash (vehicles with rain-sensing windshield wipers)**



Set the wiper switch to the off position.

If the wiper switch is in "AUTO", the wipers may operate and the wiper blades may be damaged.

# Cleaning and protecting the vehicle interior

The following procedures will help protect your vehicle's interior and keep it in top condition:

### **n Protecting the vehicle interior**

Remove dirt and dust using a vacuum cleaner. Wipe dirty surfaces with a cloth dampened with lukewarm water.

### **n Cleaning the leather areas**

1 Remove dirt and dust using a vacuum cleaner.

1 Wipe any excess dirt and dust with a soft cloth dampened with diluted detergent.

Use a diluted water solution of approximately 5% neutral wool detergent.

1 Wring out any excess water from the cloth and thoroughly wipe off all remaining traces of detergent.

1 Wipe the surface with a dry, soft cloth to remove any remaining moisture. Allow the leather to dry in a shaded and ventilated area.

### **n Cleaning the synthetic leather areas**

1 Remove loose dirt using a vacuum cleaner.

1 Apply a mild soap solution to the synthetic leather using a sponge or soft cloth.

1 Allow the solution to soak in for a few minutes. Remove the dirt and wipe off the solution with a clean, damp cloth.

### n **Caring for leather areas**

Lexus recommends cleaning the interior of the vehicle at least twice a year to maintain the quality of the vehicle's interior.

### n **Shampooing the carpets**

There are several commercial foaming-type cleaners available. Use a sponge or brush to apply the foam. Rub in overlapping circles. Do not apply water. Excellent results are obtained by keeping the carpet as dry as possible.

### n **Seat belts**

Clean with mild soap and lukewarm water using a cloth or sponge. Also check the belts periodically for excessive wear, fraying or cuts.

## CAUTION

### n **Water in the vehicle**

**I** Do not splash or spill liquid in the vehicle.

Doing so may cause electrical components etc. to malfunction or catch fire.

**I** Do not get any of the SRS components or wiring in the vehicle interior wet. (→P. 111)

An electrical malfunction may cause the airbags to deploy or not function properly, resulting in death or severe injury.

### n **Cleaning the interior (especially instrument panel)**

Do not use polish wax or polish cleaner. The instrument panel may reflect off the windshield, obstructing the driver's view and leading to an accident, resulting in death or serious injury.

 NOTICE**n Cleaning detergents**

- I Do not use the following types of detergent, as they may discolor the vehicle interior or cause streaks or damage to painted surfaces:
  - Non-seat portions: Organic substances such as benzene or gasoline, alkaline or acidic solutions, dye, or bleach
  - Seats: Acidic solutions, such as thinner, benzene, or alcohol
- I Do not use polish wax or polish cleaner. The instrument panel's or other interior part's painted surface may be damaged.

**n Preventing damage to leather surfaces**

Observe the following precautions to avoid damage to and deterioration of leather surfaces:

- I Remove any dust or dirt from leather surfaces immediately.
- I Do not expose the vehicle to direct sunlight for extended periods of time. Park the vehicle in the shade, especially during summer.
- I Do not place items made of vinyl, plastic, or that contain wax on the upholstery, as they may stick to the leather surface if the vehicle interior heats up significantly.

**n Water on the floor**

Do not wash the vehicle floor with water.

Vehicle systems such as the audio system may be damaged if water comes into contact with electrical components under the floor of vehicle. Water may also cause the body to rust.

**n Cleaning the inside of the rear window**

- I Do not use glass cleaner to clean the rear window, as this may cause damage to the rear window defogger heater wires or antenna. Use a cloth dampened with lukewarm water to gently wipe the window clean. Wipe the window in strokes running parallel to the heater wires or antenna.
- I Be careful not to scratch or damage the heater wires or antenna.

## 4-2. Maintenance

### Maintenance requirements

To ensure safe and economical driving, day-to-day care and regular maintenance are essential. It is the owner's responsibility to perform regular checks. Lexus recommends performing the following maintenance:

#### **n General maintenance**

General maintenance should be performed on a daily basis. This can be done by yourself or by a Lexus dealer.

#### **n Scheduled maintenance**

Scheduled maintenance should be performed at specified intervals according to the maintenance schedule.

For details about maintenance items and schedules, refer to the "Warranty and Service Guide", "Owner's Manual Supplement" or "Scheduled Maintenance".

#### **n Do-it-yourself maintenance**

You can perform some maintenance procedures yourself.

Please be aware that do-it-yourself maintenance may affect warranty coverage.

The use of Lexus Repair Manuals is recommended.

For details about warranty coverage, refer to the separate "Owner's Guide", "Warranty and Service Guide", "Owner's Manual Supplement" or "Warranty Booklet".

---

#### **n Repair and replacement**

It is recommended that genuine Lexus parts be used for repair to ensure performance of each system. If non-Lexus parts are used in replacement or if a repair shop other than a Lexus dealer performs repairs, confirm the warranty coverage.



**n Allow inspection and repairs to be performed by a Lexus dealer**

- I Lexus technicians are well-trained specialists and are kept up to date with the latest service information. They are well informed about the operations of all systems on your vehicle.
- I Keep a copy of the repair order. It proves that the maintenance that has been performed is under warranty coverage. If any problem should arise while your vehicle is under warranty, your Lexus dealer will promptly take care of it.

**⚠ CAUTION**

**n If your vehicle is not properly maintained**

Improper maintenance could result in serious damage to the vehicle and possible serious injury or death.

**n Handling of the battery**

- I Engine exhaust, some of its constituents, and a wide variety of automobile components contain or emit chemicals known to the State of California to cause cancer and birth defects and other reproductive harm. Work in a well ventilated area.
- I Oils, fuels and fluids contained in vehicles as well as waste produced by component wear contain or emit chemicals known to the State of California to cause cancer and birth defects or other reproductive harm. Avoid exposure and wash any affected area immediately.
- I Battery posts, terminals and related accessories contain lead and lead compounds which are known to cause brain damage. Wash your hands after handling. (→P. 474)

## 4-2. Maintenance

### General maintenance

Listed below are the general maintenance items that should be performed at the intervals specified in the “Warranty and Service Guide” or “Owner’s Manual Supplement”. It is recommended that any problem you notice should be brought to the attention of your Lexus dealer or qualified service shop for advice.

#### Engine compartment

Items	Check points
Battery	Check the indicator and connections. (→P. 474)
Brake fluid	Is the brake fluid at the correct level? (→P. 472)
Engine coolant	Is the engine coolant at the correct level? (→P. 470)
Engine oil	Is the engine oil at the correct level? (→P. 466)
Exhaust system	There should not be any fumes or strange sounds.
Radiator/condenser/hoses	The radiator and condenser should be free from foreign objects. (→P. 472)
Washer fluid	Is there sufficient washer fluid? (→P. 477)

## Vehicle interior

Items	Check points
Accelerator pedal	<ul style="list-style-type: none"> <li>• The accelerator pedal should move smoothly (without uneven pedal effort or catching).</li> </ul>
Automatic transmission “Park” mechanism	<ul style="list-style-type: none"> <li>• When parked on a slope and the shift lever is in P, is the vehicle securely stopped?</li> </ul>
Brake pedal	<ul style="list-style-type: none"> <li>• Does the brake pedal move smoothly?</li> <li>• Does the brake pedal have appropriate clearance from the floor?</li> <li>• Does the brake pedal have the correct amount of free play?</li> </ul>
Brakes	<ul style="list-style-type: none"> <li>• The vehicle should not pull to one side when the brakes are applied.</li> <li>• The brakes should work effectively.</li> <li>• The brake pedal should not feel spongy.</li> <li>• The brake pedal should not get too close to the floor when the brakes are applied.</li> </ul>
Head restraints	<ul style="list-style-type: none"> <li>• Do the head restraints move smoothly and lock securely?</li> </ul>
Indicators/buzzers	<ul style="list-style-type: none"> <li>• Do the indicators and buzzers function properly?</li> </ul>
Lights	<ul style="list-style-type: none"> <li>• Do all the lights come on?</li> <li>• Are the headlights aimed correctly? (→P. 509)</li> </ul>

Items	Check points
Parking brake	<ul style="list-style-type: none"> <li>• Does the parking brake pedal move smoothly?</li> <li>• When parked on a slope and the parking brake is on, is the vehicle securely stopped?</li> </ul>
Seat belts	<ul style="list-style-type: none"> <li>• Do the seat belts operate smoothly?</li> <li>• The seat belts should not be damaged.</li> </ul>
Seats	<ul style="list-style-type: none"> <li>• Do the seat controls operate properly?</li> </ul>
Steering wheel	<ul style="list-style-type: none"> <li>• Does the steering wheel rotate smoothly?</li> <li>• Does the steering wheel have the correct amount of free play?</li> <li>• There should not be any strange sounds coming from the steering wheel.</li> </ul>

## Vehicle exterior

Items	Check points
Doors	<ul style="list-style-type: none"> <li>• Do the doors operate smoothly?</li> </ul>
Engine hood	<ul style="list-style-type: none"> <li>• Does the engine hood lock system work properly?</li> </ul>
Fluid leaks	<ul style="list-style-type: none"> <li>• There should not be any signs of fluid leakage after the vehicle has been parked.</li> </ul>
Tires	<ul style="list-style-type: none"> <li>• Is the tire inflation pressure correct?</li> <li>• The tires should not be damaged or excessively worn.</li> <li>• Have the tires been rotated according to the maintenance schedule?</li> <li>• The wheel nuts should not be loose.</li> </ul>

### CAUTION

#### **n If the engine is running**

Turn the engine off and ensure that there is adequate ventilation before performing maintenance checks.

# Emission inspection and maintenance (I/M) programs

Some states have vehicle emission inspection programs which include OBD (On Board Diagnostics) checks. The OBD system monitors the operation of the emission control system.

**n If the malfunction indicator lamp comes on**

The OBD system determines that a problem exists somewhere in the emission control system. Your vehicle may not pass the I/M test and may need to be repaired. Contact your Lexus dealer to service the vehicle.

**n Your vehicle may not pass the I/M test in the following situations:**

**1 When the battery is disconnected or discharged**

Readiness codes that are set during ordinary driving are erased. Also, depending on your driving habits, the readiness codes may not be completely set.

**1 When the fuel tank cap is loose**

The malfunction indicator lamp comes on indicating a temporary malfunction and your vehicle may not pass the I/M test.

**n When the malfunction indicator lamp still remains on after several driving trips**

The error code in the OBD system will not be cleared unless the vehicle is driven 40 or more times.

**n If your vehicle does not pass the I/M test**

Contact your Lexus dealer to prepare the vehicle for re-testing.

### 4-3. Do-it-yourself maintenance

## Do-it-yourself service precautions

If you perform maintenance by yourself, be sure to follow the correct procedures as given in these sections.

Items	Parts and tools
Battery condition (→P. 474)	<ul style="list-style-type: none"><li>• Warm water</li><li>• Baking soda</li><li>• Grease</li><li>• Conventional wrench (for terminal clamp bolts)</li></ul>
Brake fluid level (→P. 472)	<ul style="list-style-type: none"><li>• FMVSS No.116 DOT 3 or SAE J1703 brake fluid</li><li>• Rag or paper towel</li><li>• Funnel (used only for adding brake fluid)</li></ul>
Engine coolant level (→P. 470)	<ul style="list-style-type: none"><li>• “Toyota Super Long Life Coolant” or similar high quality ethylene glycol-based non-silicate, non-amine, non-nitrite and non-borate coolant with long-life hybrid organic acid technology. For the U.S.A.: “Toyota Super Long Life Coolant” is pre-mixed with 50% coolant and 50% deionized water. For Canada: “Toyota Super Long Life Coolant” is pre-mixed with 55% coolant and 45% deionized water.</li><li>• Funnel (used only for adding engine coolant)</li></ul>

### 4-3. Do-it-yourself maintenance

Items	Parts and tools
Engine oil level (→P. 466)	<ul style="list-style-type: none"><li>• “Toyota Genuine Motor Oil” or equivalent</li><li>• Rag or paper towel</li><li>• Funnel (used only for adding engine oil)</li></ul>
Fuses (→P. 498)	<ul style="list-style-type: none"><li>• Fuse with same amperage rating as original</li></ul>
Tire inflation pressure (→P. 487)	<ul style="list-style-type: none"><li>• Tire pressure gauge</li><li>• Compressed air source</li></ul>
Headlight aim (→P. 509)	<ul style="list-style-type: none"><li>• Phillips-head screwdriver</li></ul>
Radiator and condenser (→P. 472)	—
Washer fluid (→P. 477)	<ul style="list-style-type: none"><li>• Water washer fluid containing anti-freeze (for winter use)</li><li>• Funnel (used only for adding water or washer fluid)</li></ul>



 **CAUTION**

The engine compartment contains many mechanisms and fluids that may move suddenly, become hot, or become electrically energized. To avoid death or serious injury, observe the following precautions:

**n When working on the engine compartment**

- I** Keep hands, clothing and tools away from the moving fan and engine drive belt.
- I** Be careful not to touch the engine, radiator, exhaust manifold, etc. right after driving as they may be hot. Oil and other fluids may also be hot.
- I** Do not leave anything that may burn easily, such as paper or rags, in the engine compartment.
- I** Do not smoke, cause sparks or expose an open flame to fuel or the battery. Fuel and battery fumes are flammable.
- I** Be extremely cautious when working on the battery. It contains poisonous and corrosive sulfuric acid.

**n When working near the electric cooling fan or radiator grille**

Be sure the “ENGINE START STOP” switch is off.

With the “ENGINE START STOP” switch in IGNITION ON mode, the electric cooling fan may automatically start to run if the air conditioning is on and/or the coolant temperature is high. (→P. 472)

**n Safety glasses**

Wear safety glasses to prevent flying or falling material, fluid spray, etc. from getting in the eyes.

 **NOTICE****n If you remove the air cleaner filter**

Driving with the air cleaner filter removed may cause excessive engine wear due to dirt in the air. Also a backfire could cause a fire in the engine compartment.

## 4-3. Do-it-yourself maintenance

### Hood

Release the lock from the inside of the vehicle to open the hood.

#### STEP 1



Pull the hood lock release lever.

The hood will pop up slightly.

#### STEP 2



Pull up the hood catch and lift the hood.

#### CAUTION

##### Pre-driving check

Check that the hood is fully closed and locked.

If the hood is not locked properly, it may open while the vehicle is in motion and cause an accident, which may result in death or serious injury.

## 4-3. Do-it-yourself maintenance

### Positioning a floor jack

When raising your vehicle with a floor jack, position the jack correctly. Improper placement may damage your vehicle or cause injury.

#### n Front



#### n Rear



**! CAUTION**

**n When raising your vehicle**

Make sure to observe the following precautions to reduce the possibility of death or serious injury:



**1** Lift up the vehicle using a floor jack such as the one shown in the illustration.

- 1** When using a floor jack, follow the instructions of the manual provided with the jack.
- 1** Do not use the jack that was supplied with your vehicle.
- 1** Do not put any part of your body underneath the vehicle when it is supported only by the floor jack.
- 1** Always use floor jack and/or automotive jack stands on a solid, flat, level surface.
- 1** Do not start the engine while the vehicle is supported by the floor jack.
- 1** Stop the vehicle on level, firm ground, firmly set the parking brake and shift the shift lever to P.
- 1** Make sure to set the floor jack properly at the jack point.  
Raising the vehicle with an improperly positioned floor jack will damage the vehicle and may cause the vehicle to fall off the floor jack.
- 1** Do not raise the vehicle while someone is in the vehicle.
- 1** When raising the vehicle, do not place any objects on top of or underneath the floor jack.

## 4-3. Do-it-yourself maintenance

### Engine compartment

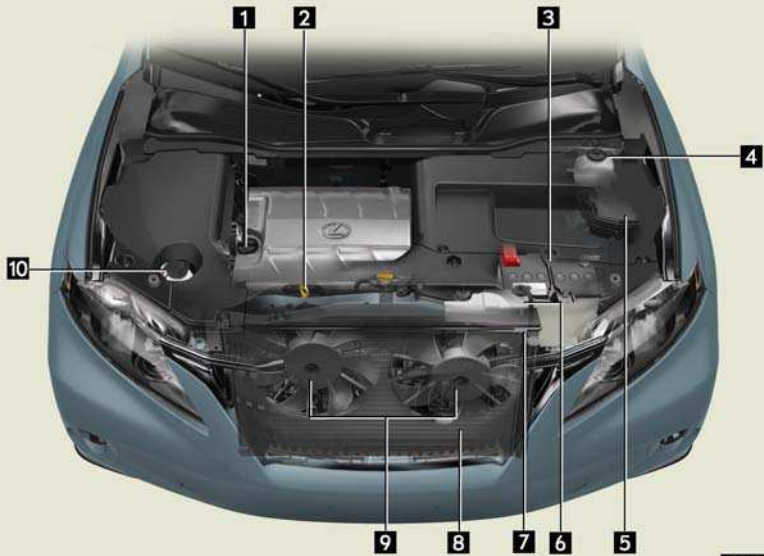

- |   |  |
|---|--|
| <b>1</b> Engine oil filler cap<br>(→P. 466)     | <b>6</b> Engine coolant reservoir<br>(→P. 470) |
| <b>2</b> Engine oil level dipstick<br>(→P. 466) | <b>7</b> Condenser<br>(→P. 472)                |
| <b>3</b> Battery<br>(→P. 474)                   | <b>8</b> Radiator<br>(→P. 472)                 |
| <b>4</b> Brake fluid reservoir<br>(→P. 472)     | <b>9</b> Electric cooling fans<br>(→P. 477)    |
| <b>5</b> Fuse box<br>(→P. 498)                  | <b>10</b> Washer fluid tank<br>(→P. 477)       |

## Engine compartment covers

### n Removing the engine compartment covers

#### ► Outside

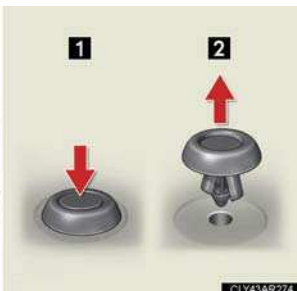

#### ► Front

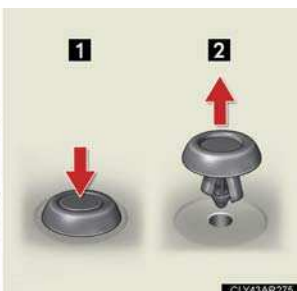
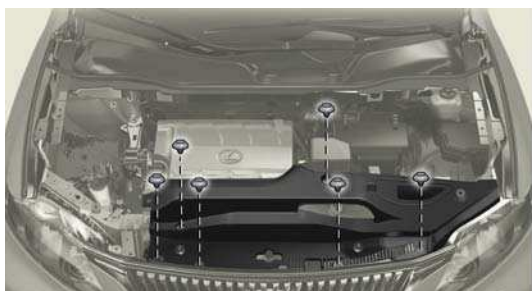

### n Installing the clips

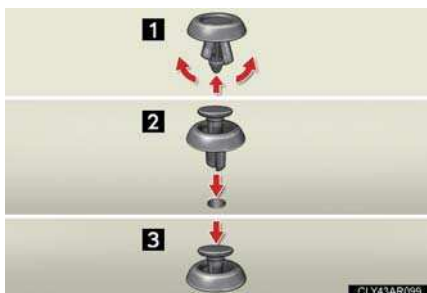

## Battery cover

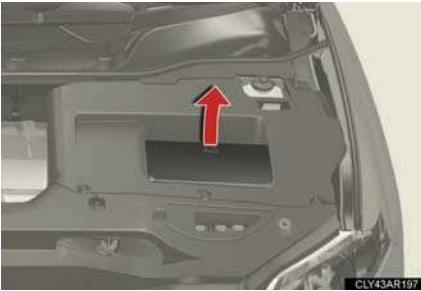

Removing the battery cover.

### NOTICE

#### **n** When installing the battery cover

Securely install the cover over the battery. Failure to do so may cause water to enter the engine compartment when it rains or the vehicle is washed, resulting in a malfunction.

## Engine oil

With the engine at operating temperature and turned off, check the oil level on the dipstick.

### n Checking the engine oil

**STEP 1** Park the vehicle on level ground. After turning off the engine, wait more than 5 minutes for the oil to drain back into the bottom of the engine.

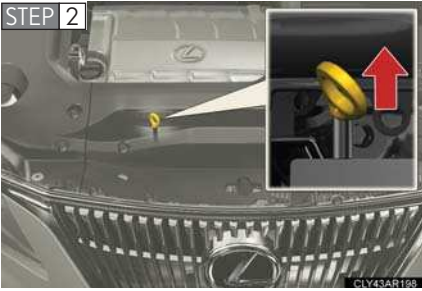

Hold a rag under the end and pull the dipstick out.

**STEP 3** Wipe the dipstick clean.

**STEP 4** Reinsert the dipstick fully.

**STEP 5** Holding a rag under the end, pull the dipstick out and check the oil level.

**STEP 6** Wipe the dipstick and reinsert it fully.

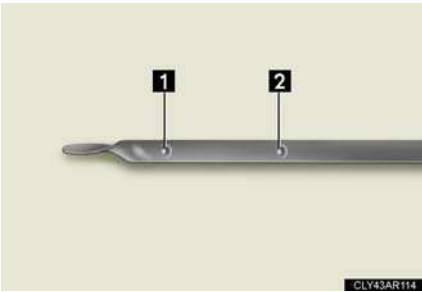

**1** Low

**2** Full



## n Adding engine oil



If the oil level is below or near the low level mark, add engine oil of the same type as that already in the engine.

Make sure to check the oil type and prepare the items needed before adding oil.

Engine oil selection	→P. 597
Items	Clean funnel

**STEP 1** Remove the oil filler cap by turning it counterclockwise.

**STEP 2** Add engine oil slowly, checking the dipstick.

**STEP 3** Install the oil filler cap by turning it clockwise.

About 1.6 qt. (1.5 L, 1.3 Imp. qt.) is required to raise the oil level from low to full on the dipstick.

### ■ Engine oil consumption

- 1 The amount of engine oil consumed depends on the oil viscosity, the quality of the oil and the way the vehicle is driven.
- 1 More oil is consumed under driving conditions such as high speeds and frequent acceleration and deceleration.
- 1 A new engine consumes more oil.
- 1 When judging the amount of oil consumption, keep in mind that the oil may have become diluted, making it difficult to judge the true level accurately.
- 1 Oil consumption: Max. 1.1 qt./600 miles (0.9 Imp. qt./600 miles, 1.0 L/1000 km)
- 1 If your vehicle consumes more than 1.1 qt. (1.0 L, 0.9 Imp. qt.) every 600 miles (1000 km), contact your Lexus dealer.

### ■ After changing the engine oil (U. S. A. only)

The engine oil maintenance data should be reset. Perform the following procedure:

**STEP 1** Display the trip meter "A" (→P. 167), then turn the "ENGINE START STOP" switch off.

**STEP 2** While pressing the "ODO/TRIP" button, turn the "ENGINE START STOP" switch to ON mode.



Keep the "ODO/TRIP" button pressed for about 5 seconds. The resetting procedure is complete when "000000" in the trip meter flashes once and the message in the multi-information display disappears.

 CAUTION**n Used engine oil**

- I** Used engine oil contains potentially harmful contaminants which may cause skin disorders such as inflammation or skin cancer, so care should be taken to avoid prolonged and repeated contact. To remove used engine oil from your skin, wash thoroughly with soap and water.
- I** Dispose of used oil and filters only in a safe and acceptable manner. Do not dispose of used oil and filters in household trash, in sewers or onto the ground. Call your Lexus dealer, service station or auto parts store for information concerning recycling or disposal.
- I** Do not leave used engine oil within the reach of children.

 NOTICE**n To prevent serious engine damage**

Check the oil level on a regular basis.

**n When replacing the engine oil**

- I** Be careful not to spill engine oil on the vehicle components.
- I** Avoid overfilling, or the engine could be damaged.
- I** Check the oil level on the dipstick every time you refill the vehicle.
- I** Be sure the engine oil filler cap is properly tightened.

## Engine coolant

The coolant level is satisfactory if it is between the “FULL” and “LOW” lines on the reservoir when the engine is cold.

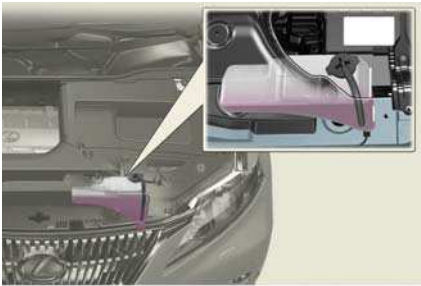

- 1 Reservoir cap
- 2 “FULL” line
- 3 “LOW” line

If the level is on or below the “LOW” line, add coolant up to the “FULL” line. (→P. 587)

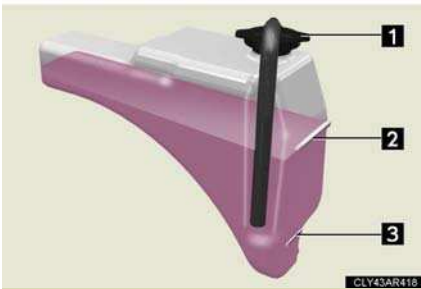

### ■ Coolant selection

Only use “Toyota Super Long Life Coolant” or a similar high quality ethylene glycol based non-silicate, non-amine, non-nitrite, and non-borate coolant with long-life hybrid organic acid technology.

U.S.A.: “Toyota Super Long Life Coolant” is a mixture of 50% coolant and 50% deionized water. (Minimum temperature: -31°F [-35°C])

Canada: “Toyota Super Long Life Coolant” is a mixture of 55% coolant and 45% deionized water. (Minimum temperature: -44°F [-42°C])

For more details about coolant, contact your Lexus dealer.

**n If the coolant level drops within a short time after replenishing**

Visually check the radiator, hoses, radiator cap, drain cock and water pump.

If you cannot find a leak, have your Lexus dealer test the cap and check for leaks in the cooling systems.

 **CAUTION**

**n When the engine is hot**

Do not remove the radiator cap.

The cooling system may be under pressure and may spray hot coolant if the cap is removed, causing burns or other injuries.

 **NOTICE**

**n When adding engine coolant**

Coolant is neither plain water nor straight antifreeze. The correct mixture of water and antifreeze must be used to provide proper lubrication, corrosion protection and cooling. Be sure to read the antifreeze or coolant label.

**n If you spill coolant**

Be sure to wash it off with water to prevent damage to parts or paint.

### Radiator and condenser

Check the radiator and condenser, and clear away any foreign objects. If either of the above parts are extremely dirty or you are not sure of their condition, have your vehicle checked by your Lexus dealer.

#### CAUTION

##### **n** When the engine is hot

Do not touch the radiator or condenser, as they may be hot and cause burns.

### Brake fluid

##### **n** Checking fluid level



The brake fluid level should be between the “MAX” and “MIN” lines on the tank.

##### **n** Adding fluid

Make sure to check the fluid type and prepare the necessary item.

Fluid type	FMVSS No.116 DOT 3 or SAE J1703
Items	Clean funnel

**n Brake fluid can absorb moisture from the air**

Excess moisture in the brake fluid can cause a dangerous loss of braking efficiency. Use only newly opened brake fluid.

** CAUTION****n When filling the reservoir**

Take care because brake fluid can harm your hands or eyes and damage painted surfaces.

If fluid gets on your hands or in your eyes, flush the affected area with clean water immediately.

If you still experience discomfort, see a doctor.

** NOTICE****n If the fluid level is low or high**

It is normal for the brake fluid level to go down slightly as the brake pads wear out or when the fluid level in the accumulator is high.

If the reservoir needs frequent refilling, there may be a serious problem.

## Battery

Check the battery as follows.

### n Battery exterior

Make sure that the battery terminals are not corroded and that there are no loose connections, cracks, or loose clamps.

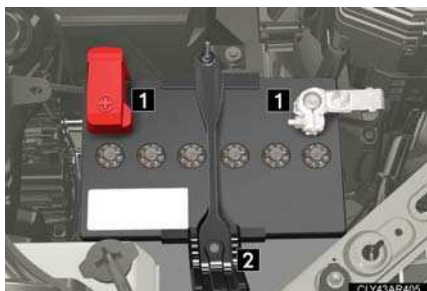

**1** Terminals

**2** Hold-down clamp

### n Before recharging

When recharging, the battery produces hydrogen gas which is flammable and explosive. Therefore, observe the following before recharging:

- 1 If recharging with the battery installed on the vehicle, be sure to disconnect the ground cable.
- 1 Make sure the power switch on the charger is off when connecting and disconnecting the charger cables to the battery.

### n After recharging/reconnecting the battery

In some cases, the engine may not start. Follow the procedure below to initialize the system.

**STEP 1** Shift the shift lever to P, and turn the “ENGINE START STOP” switch OFF.

**STEP 2** Open and close any of the doors.

**STEP 3** Start the engine. (If the engine does not start first time, repeat the procedure.)

If the engine will not start even after multiple attempts at the above method, contact your Lexus dealer.



**⚠ CAUTION****n Chemicals in the battery**

Batteries contain poisonous and corrosive sulfuric acid and may produce hydrogen gas which is flammable and explosive. To reduce the risk of death or serious injury, take the following precautions while working on or near the battery:

- I** Do not cause sparks by touching the battery terminals with tools.
- I** Do not smoke or light a match near the battery.
- I** Avoid contact with eyes, skin and clothes.
- I** Never inhale or swallow electrolyte.
- I** Wear protective safety glasses when working near the battery.
- I** Keep children away from the battery.

**n Where to safely charge the battery**

Always charge the battery in an open area. Do not charge the battery in a garage or closed room where there is insufficient ventilation.

**n How to recharge the battery**

Only perform a slow charge (5 A or less). The battery may explode if charged at a quicker rate.

**n Emergency measures regarding electrolyte**

- I** If electrolyte gets in your eyes  
Flush your eyes with clean water for at least 15 minutes and get immediate medical attention. If possible, continue to apply water with a sponge or cloth while traveling to the nearest medical facility.
- I** If electrolyte gets on your skin  
Wash the affected area thoroughly. If you feel pain or burning, get medical attention immediately.
- I** If electrolyte gets on your clothes  
It can soak through clothing on to your skin. Immediately take off the clothing and follow the procedure above if necessary.
- I** If you accidentally swallow electrolyte  
Drink a large quantity of water or milk. Follow with milk of magnesia, beaten raw egg or vegetable oil. Get emergency medical attention immediately.

### NOTICE

#### **n When recharging the battery**

Never recharge the battery while the engine is running. Also, be sure all accessories are turned off.

## Washer fluid



If any washer does not work or the warning message appears on the multi-information display, the washer tank may be empty. Add washer fluid.

### CAUTION

#### **n When adding washer fluid**

Do not add washer fluid when the engine is hot or running as washer fluid contains alcohol and may catch fire if spilled on the engine etc.

### NOTICE

#### **n Do not use any fluid other than washer fluid**

Do not use soapy water or engine antifreeze instead of washer fluid. Doing so may cause streaking on the vehicle's painted surfaces.

#### **n Diluting washer fluid**

Dilute washer fluid with water as necessary. Refer to the freezing temperatures listed on the washer fluid tank.

## 4-3. Do-it-yourself maintenance

# Tires

Replace or rotate tires in accordance with maintenance schedules and treadwear.

### n Checking tires



- 1 New tread
- 2 Treadwear indicator
- 3 Worn tread

The location of treadwear indicators is shown by the “TWI” or “Δ” marks, etc., molded on the sidewall of each tire.

Check spare tire condition and pressure if not rotated.

### n Tire rotation

#### ► Vehicles with a compact spare tire

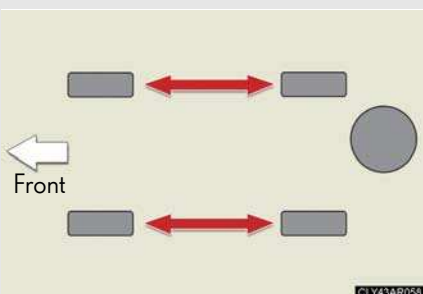

Rotate the tires in the order shown.

To equalize tire wear and extend tire life, Lexus recommends that tire rotation is carried out at the same interval as tire inspection.

#### ► Vehicles with a full-size spare tire

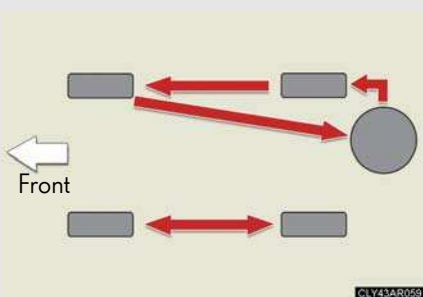

Rotate the tires in the order shown.

To equalize tire wear and extend tire life, Lexus recommends that tire rotation is carried out at the same interval as tire inspection.

**n The tire pressure warning system**

Your Lexus is equipped with a tire pressure warning system that uses tire pressure warning valves and transmitters to detect low tire inflation pressure before serious problems arise. (→P. 537, 545)

**Installing tire pressure warning valves and transmitters**

When replacing tires or wheels, tire pressure warning valves and transmitters must also be installed.

When new tire pressure warning valves and transmitters are installed, new tire pressure warning valve and transmitter ID codes must be registered in the tire pressure warning computer and the tire pressure warning system must be initialized. Have the tire pressure warning valve and transmitter ID codes registered by your Lexus dealer. (→P. 481)

**Initializing the tire pressure warning system****n The tire pressure warning system must be initialized in the following circumstances:**

- 1 When the tire inflation pressure is changed such as when changing travelling speed or load weight
- 1 When changing the tire size

When the tire pressure warning system is initialized, the current tire inflation pressure is set as the benchmark pressure.

### n How to initialize the tire pressure warning system

**STEP 1** Park the vehicle in safe place and turn the “ENGINE START STOP” switch off.

While the vehicle is moving, initialization is not performed.

**STEP 2** Adjust the tire inflation pressure to the specified cold tire inflation pressure level. (→P. 602)

Make sure to adjust the tire pressure to the specified cold tire inflation pressure level. The tire pressure warning system will operate based on this pressure level.

**STEP 3** Turn the “ENGINE START STOP” switch to IGNITION ON mode.



Press and hold the tire pressure warning reset switch until the tire pressure warning light flashes slowly 3 times.

**STEP 5** Wait for a few minutes in “ENGINE START STOP” switch to on, and then turn the “ENGINE START STOP” switch off.

## Registering ID codes

The tire pressure warning valve and transmitter is equipped with a unique ID code. When replacing a tire pressure warning valve and transmitter, it is necessary to register the ID code. Have the ID code registered by your Lexus dealer.

### n **When to replace your vehicle's tires**

Tires should be replaced if:

- 1 You have tire damage such as cuts, splits, cracks deep enough to expose the fabric, and bulges indicating internal damage.
- 1 A tire goes flat repeatedly or cannot be properly repaired due to the size or location of a cut or other damage.

If you are not sure, consult with your Lexus dealer.

### n **Replacing tires and wheels**

If the ID code of the tire pressure warning valve and transmitter is not registered, the tire pressure warning system will not work properly. After driving for about 20 minutes, the tire pressure warning light flashes for 1 minute and stays on to indicate a system malfunction.

### n **Tire life**

- 1 Standard tire over 6 years old must be checked by a qualified technician even if they have seldom or never been used or damage is not obvious.
- 1 The compact spare tire could be deformed gradually in the long term even if you don't use it. Be sure to have the compact spare tire checked by your Lexus dealer if it is over 5 years.

### n **If the tread on snow tires wears down below 0.16 in. (4 mm)**

The effectiveness of the tires as snow tires is lost.

### n Maximum load of tire

Check that the number given by dividing the maximum load by 1.10 of the replacement tire is greater than 1/2 of the Gross Axle Weight Ratings (GAWR) of either the front axle or the rear axle, whichever is greater.



For the GAWR, see the Certification Label. For the maximum load of the tire, see the load limit at maximum cold tire inflation pressure mentioned on the sidewall of the tire. (→P. 609)

### n Tire types

#### 1 Summer tires

Summer tires are high-speed performance tires best suited to highway driving under dry conditions. Since summer tires do not have the same traction performance as snow tires, summer tires are inadequate for driving on snow-covered or icy roads. For driving on snow-covered roads or icy roads, the use of snow tires is recommended. When installing snow tires, be sure to replace all four tires.

#### 2 All season tires

All season tires are designed to provide better traction in snow and to be adequate for driving in most winter conditions, as well as for use year round. All season tires, however, do not have adequate traction performance compared with snow tires in heavy or loose snow. Also, all season tires fall short in acceleration and handling performance compared with summer tires in highway driving.

#### 3 Snow tires

For driving on snow-covered roads or icy roads, we recommend using snow tires. If you need snow tires, select tires of the same size, construction and load capacity as the originally installed tires. Since your vehicle has radial tires as original equipment, make sure your snow tires also have radial construction. Do not install studded tires without first checking local regulations for possible restrictions. Snow tires should be installed on all wheels. (→P. 254)



#### n **Initializing the tire pressure warning system**

Initialize the tire pressure warning system with the tire inflation pressure adjusted to the specified level.

#### n **If you push the tire pressure warning reset switch accidentally**

If initialization is performed, adjust the tire inflation pressure to the specified level and initialize the tire pressure warning system again.

#### n **When the initialization of the tire pressure warning system has failed**

Initialization can be completed in a few minutes. However, in the following cases, the settings have not been recorded and the system will not operate properly. If repeated attempts to record tire inflation pressure settings are unsuccessful, have the vehicle inspected by your Lexus dealer.

1 When operating the tire pressure warning reset switch, the tire pressure warning light does not flash 3 times.

1 After carrying out the initialization procedure, the tire pressure warning light flashes for 1 minute then stays on after driving for 20 minutes.

#### n **Routine tire inflation pressure checks**

The tire pressure warning system does not replace routine tire inflation pressure checks. Make sure to check tire inflation pressure as part of your routine of daily vehicle checks.

### n **Tire pressure warning system certification**

TPMS Transmitter FCC ID: PAXPMV107J

IC ID: 3729A-PMV107J

TPMS Receiver FCC ID: HYQ13BCX

IC ID: 1551A-13BCX

#### ► For vehicles sold in the U.S.A.

This device complies with part 15 of the FCC Rules. Operation is subject to the following two conditions: (1) This device may not cause harmful interference, and (2) this device must accept any interference received, including interference that may cause undesired operation.

#### FCC WARNING:

Changes or modifications not expressly approved by the party responsible for compliance could void the user's authority to operate the equipment.

#### ► For vehicles sold in Canada

Operation is subject to the following two conditions: (1) this device may not cause interference, and (2) this device must accept any interference, including interference that may cause undesired operation of the device.

L'utilisation de ce dispositif est autorisée seulement aux deux conditions suivantes: (1) il ne doit pas produire de brouillage, et (2) l'utilisateur du dispositif doit être prêt à accepter tout brouillage radioélectrique reçu, même si ce brouillage est susceptible de compromettre le fonctionnement du dispositif.

 **CAUTION****n Tire pressure warning system operation**

The tire pressure warning system may not provide warning immediately if a tire bursts or if sudden air leakage occurs.

**n When inspecting or replacing tires**

Observe the following precautions to prevent accidents. Failure to do so may cause damage to parts of the drive train, as well as dangerous handling characteristics, which may lead to an accident resulting in death or serious injury.

**I** Do not mix tires of different makes, models or tread patterns. Also, do not mix tires of remarkably different treadwear.

**I** Do not use tire sizes other than those recommended by Lexus.

**I** Do not mix differently constructed tires (radial, bias-belted or bias-ply tires).

**I** Do not mix summer, all season and snow tires.

**I** Do not use tires that have been used on another vehicle.

Do not use tires if you do not know how they were used previously.

**n When initializing the tire pressure warning system**

Do not push the tire pressure warning reset switch without first adjusting the tire inflation pressure to the specified level. Otherwise, the tire pressure warning light may not come on even if the tire inflation pressure is low, or it may come on when the tire inflation pressure is actually normal.

 NOTICE

**n Repairing or replacing tires, wheels, tire pressure warning valves, transmitters and tire valve caps**

**I** When removing or fitting the wheels, tires or the tire pressure warning valve and transmitter, contact your Lexus dealer as the tire pressure warning valves and transmitter may be damaged if not handled correctly.

**I** When replacing tire valve caps, do not use tire valve caps other than those specified. The cap may become stuck.

**n To avoid damage to the tire pressure warning valves and transmitters**

When a tire is repaired with liquid sealants, the tire pressure warning valve and transmitter may not operate properly. If a liquid sealant is used, contact your Lexus dealer or other qualified service shop as soon as possible. Make sure to replace the tire pressure warning valve and transmitter when replacing the tire. (→P. 479)

**n Driving on rough roads**

Take particular care when driving on roads with loose surfaces or potholes.

These conditions may cause losses in tire inflation pressure, reducing the cushioning ability of the tires. In addition, driving on rough roads may cause damage to the tires themselves, as well as the vehicle's wheels and body.

**n If tire inflation pressures become low while driving**

Do not continue driving, or your tires and/or wheels may be ruined.

## 4-3. Do-it-yourself maintenance

### Tire inflation pressure

#### n Tire inflation pressure

The recommended cold tire inflation pressure and tire size is displayed on the tire and loading information label. (→P. 602)



## n Inspection and adjustment procedure



1 Tire valve

2 Tire pressure gauge

**STEP 1** Remove the tire valve cap.

**STEP 2** Press the tip of the tire pressure gauge onto the tire valve.

**STEP 3** Read the pressure using the gauge graduations.

**STEP 4** If the tire inflation pressure is not at the recommended level, adjust the pressure.

If you add too much air, press the center of the valve to deflate.

**STEP 5** After completing the tire inflation pressure measurement and adjustment, apply soapy water to the valve and check for leakage.

**STEP 6** Put the tire valve cap back on.

---

**n Tire inflation pressure check interval**

You should check tire inflation pressure every two weeks, or at least once a month. Do not forget to check the spare.

**n Effects of incorrect tire inflation pressure**

Driving with incorrect tire inflation pressure may result in the following:

- l Reduced fuel efficiency
- l Reduced driving comfort and tire life
- l Reduced safety
- l Damage to the drive train

If a tire needs frequent inflating, have it checked by your Lexus dealer.

**n Instructions for checking tire pressure**

When checking tire inflation pressure, observe the following:

- l Check only when the tires are cold.  
If your vehicle has been parked for at least 3 hours and has not been driven for more than 1 mile or 1.5 km, you will get an accurate cold tire inflation pressure reading.
- l Always use a tire pressure gauge.  
The appearance of the tire can be misleading. In addition, tire inflation pressures that are even just a few pounds off can degrade ride and handling.
- l Do not reduce tire inflation pressure after driving. It is normal for the tire inflation pressure to be higher after driving.
- l Never exceed the vehicle capacity weight.  
Passengers and luggage weight should be placed so that the vehicle is balanced.

 **CAUTION**

**n Proper inflation is critical to save tire performance**

Keep your tires properly inflated. Otherwise, the following conditions may occur and result in an accident causing death or serious injury:

- I Excessive wear**
- I Uneven wear**
- I Poor handling**
- I Possibility of blowouts resulting from overheated tires**
- I Poor sealing of the tire bead**
- I Wheel deformation and/or tire separation**
- I A greater possibility of tire damage from road hazards**

 **NOTICE**

**n When inspecting and adjusting tire inflation pressure**

Be sure to put the tire valve caps back on.

Without the valve caps, dirt or moisture could get into the valve and cause air leakage, which could result in an accident. If the caps are lost, replace them as soon as possible.



# Wheels

If a wheel is bent, cracked or heavily corroded, it should be replaced. Otherwise, the tire may separate from the wheel or cause a loss of handling control.

### n Wheel selection

When replacing wheels, care should be taken to ensure that they are equivalent to those removed in load capacity, diameter, rim width, and inset\*.

Replacement wheels are available at your Lexus dealer.

\*: Conventionally referred to as “offset”.

Lexus does not recommend using the following:

- 1 Wheels of different sizes or types
- 1 Used wheels
- 1 Bent wheels that have been straightened

### n Aluminum wheel precautions

- 1 Use only Lexus wheel nuts and wrenches designed for use with your aluminum wheels.
- 1 When rotating, repairing or changing your tires, check that the wheel nuts are still tight after driving 1000 miles (1600 km).
- 1 Be careful not to damage the aluminum wheels when using tire chains.
- 1 Use only Lexus genuine balance weights or equivalent and a plastic or rubber hammer when balancing your wheels.

---

### n When replacing wheels

The wheels of your vehicle are equipped with tire pressure warning valves and transmitters that allow the tire pressure warning system to provide advanced warning in the event of a loss in tire inflation pressure. Whenever wheels are replaced, tire pressure warning valves and transmitters must be installed. (→P. 479)

### CAUTION

#### **n When replacing wheels**

- I** Do not use wheels that are a different size from those recommended in the Owner's Manual, as this may result in a loss of handling control.
- I** Never use an inner tube in a leaking wheel which is designed for a tubeless tire. Doing so may result in an accident, causing death or serious injury.

### NOTICE

#### **n Replacing tire pressure warning valves and transmitters**

- I** Because tire repair or replacement may affect the tire pressure warning valves and transmitters, make sure to have tires serviced by your Lexus dealer or other qualified service shop. In addition, make sure to purchase your tire pressure warning valves and transmitters at your Lexus dealer.
- I** Ensure that only genuine Lexus wheels are used on your vehicle. Tire pressure warning valves and transmitters may not work properly with non-genuine wheels.

## 4-3. Do-it-yourself maintenance

### Air conditioning filter

The air conditioning filter must be cleaned or changed regularly to maintain air conditioning efficiency.

#### n Removal method

**STEP 1** Set the air conditioning system to recirculated mode.  
(→P. 277)

The air conditioning filter case cannot be removed with the system in outside air mode.

**STEP 2** Turn the “ENGINE START STOP” switch off.

**STEP 3**

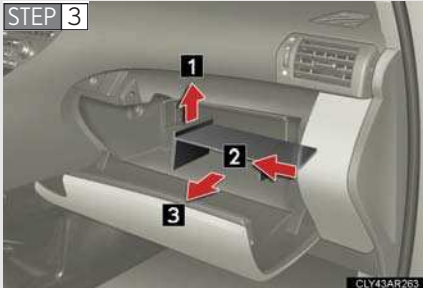

Open the glove box door. Lift and remove the partition.

**STEP 4**

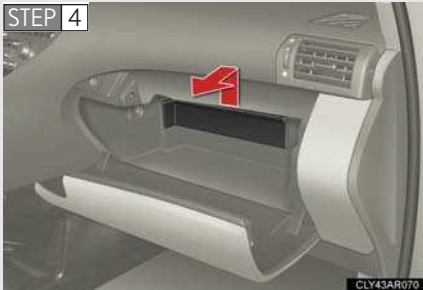

Remove the glove box cover.

**STEP 5**

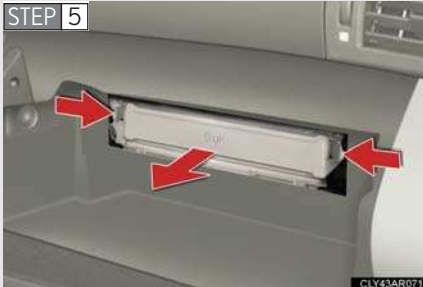

Remove the filter cover.

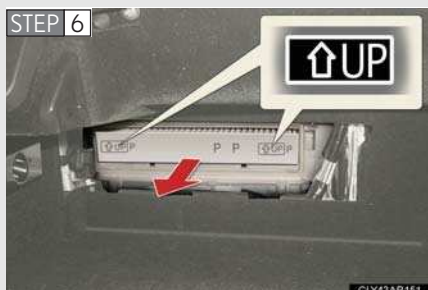

To remove the filter case, lift it up and pull it out. Replace the filter with a new one.

The “↑UP” mark shown on the filter should be pointing up.

### n Cleaning method



If the filter is dirty, clean by blowing compressed air through the filter from the underside.

Hold the air gun 2 in. (5 cm) from the filter and blow for approximately 2 minutes at 72 psi (500 kPa, 5.0 kgf/cm<sup>2</sup> or bar).

If an air gun is not available, have the filter cleaned by your Lexus dealer.

### n Checking interval

Inspect and replace the air conditioning filter according to the maintenance schedule. In dusty areas or areas with heavy traffic flow, early replacement may be required. (For scheduled maintenance information, please refer to the “Owner's Manual Supplement” or “Scheduled Maintenance”.)

### n If air flow from the vents decreases dramatically

The filter may be clogged. Check the filter and replace if necessary.

 NOTICE**n To prevent damage to the system**

- I When using the air conditioning system, make sure that a filter is always installed.
- I When cleaning the filter, do not clean with water.

## 4-3. Do-it-yourself maintenance

### Electronic key battery

Replace the battery with a new one if it is depleted.

**n** You will need the following items:

- 1 Flathead screwdriver
- 1 Small Phillips-head screwdriver
- 1 Lithium battery (CR1632)

**n** Replacing the battery

STEP 1



CLY43AR118

Take out the mechanical key.

STEP 2



CLY43AR119

Remove the cover.

STEP 3



CLY43AR149

Remove the depleted battery.

Insert a new battery with the “+” terminal facing up.

#### n Use a CR1632 lithium battery

- 1 Batteries can be purchased at your Lexus dealer, local electrical appliance shops or camera stores.
- 1 Replace only with the same or equivalent type recommended by the manufacturer.
- 1 Dispose of used batteries according to the local laws.

#### n If the electronic key battery is discharged

The following symptoms may occur:

- 1 The smart access system with push-button start and wireless remote control will not function properly.
- 1 The operational range is reduced.

#### n When the card key battery needs to be replaced (if equipped)

The battery for the card key is available only at Lexus dealers. Your Lexus dealer can replace the battery for you.

### CAUTION

#### n Removed battery and other parts

Keep away from children. These parts are small and if swallowed by a child, they can cause choking. Failure to do so could result in death or serious injury.

### NOTICE

#### n For normal operation after replacing the battery

Observe the following precautions to prevent accidents:

- 1 Always work with dry hands.  
Moisture may cause the battery to rust.
- 1 Do not touch or move any other components inside the remote control.
- 1 Do not bend either of the battery terminals.

## 4-3. Do-it-yourself maintenance

### Checking and replacing fuses

If any of the electrical components do not operate, a fuse may have blown. If this happens, check and replace the fuses as necessary.

**STEP 1** Turn the “ENGINE START STOP” switch off.

**STEP 2** Remove the engine compartment cover. (→P. 464)

**STEP 3** Open the fuse box cover.

▶ Engine compartment

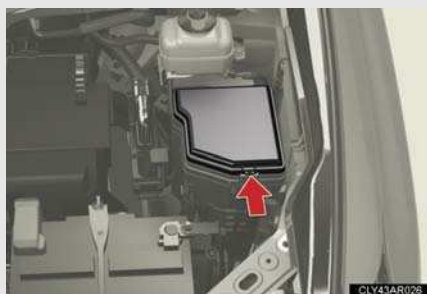

Push the tab in and lift the lid off.

▶ Driver's side instrument panel



Remove the lid.

**STEP 4** After a system failure, see “Fuse layout and amperage ratings” for details about which fuse to check. (→P. 501)

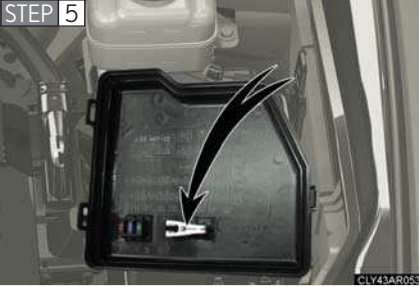

**STEP 5****STEP 6** Check if the fuse has blown.

## ► Type A

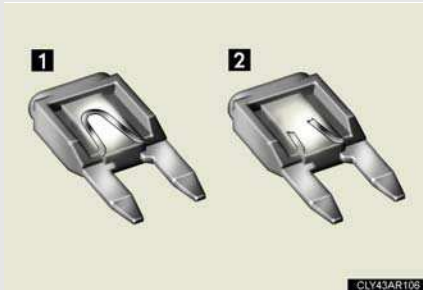

## ► Type B

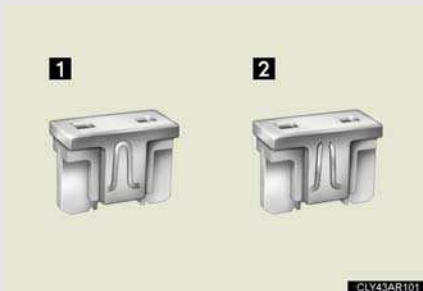

Remove the fuse with the pull-out tool.

**1** Normal fuse**2** Blown fuse

Replace the blown fuse with a new fuse of an appropriate amperage rating. The amperage rating can be found on the fuse box lid.

**1** Normal fuse**2** Blown fuse

Replace the blown fuse with a new fuse of an appropriate amperage rating. The amperage rating can be found on the fuse box lid.

► Type C

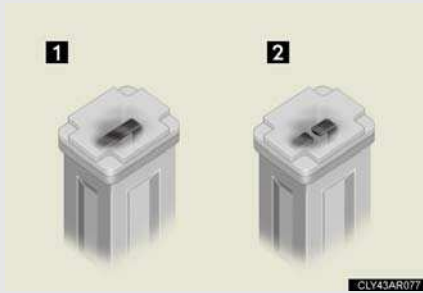

1 Normal fuse

2 Blown fuse

Replace the blown fuse with a new fuse of an appropriate amperage rating. The amperage rating can be found on the fuse box lid.

► Type D

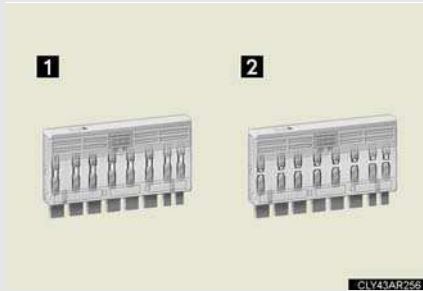

1 Normal fuse

2 Blown fuse

Replace the blown fuse with a new fuse of an appropriate amperage rating. The amperage rating can be found on the fuse box lid.

► Type E

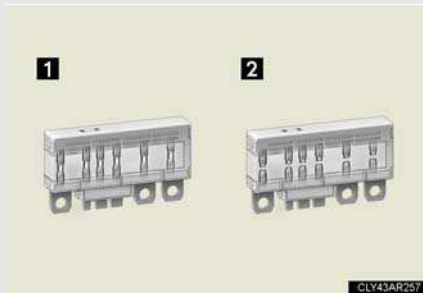

1 Normal fuse

2 Blown fuse

Replace the blown fuse with a new fuse of an appropriate amperage rating. The amperage rating can be found on the fuse box lid.

## Fuse layout and amperage ratings

### n Engine compartment

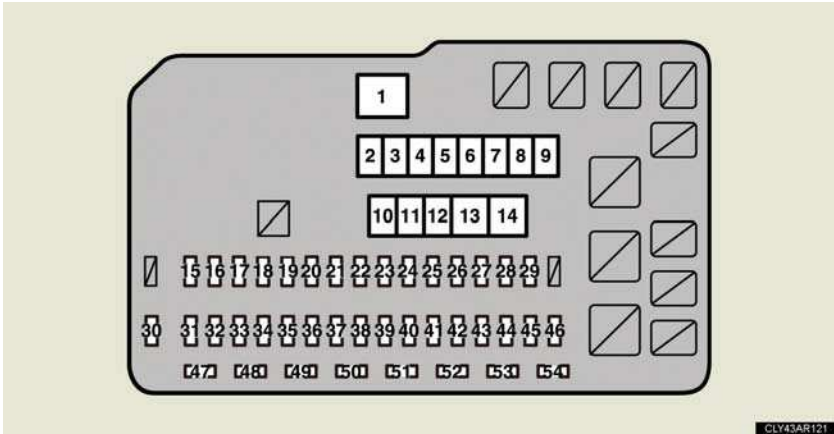

Fuse	Ampere	Circuit
1	80 A	Electric cooling fans
2	50 A	Rear window defogger
3	50 A	—
4	50 A	Air conditioning system
5	30 A	—
6	40 A	—
7	30 A	Anti-lock brake system
8	30 A	Headlight cleaner
9	30 A	Power back door system
10	30 A	Starter system

Fuse		Ampere	Circuit
11	PD	50 A	Daytime running light system, A/F, H-LP RH HI, H-LP LH LO, H-LP RH LO, H-LP LH HI, HORN, S-HORN, multiplex communication system, multiport fuel injection system/ sequential multiport fuel injection system
12	ABS NO. 1	50 A	Anti-lock brake system
13	EPS	60 A	Electric power steering system
14	ALT	140 A	FUEL OPN, DR LOCK, OBD, RR FOG, S/ROOF, 4WD, INVERTER, ECU IG1 NO. 1, ECU IG1 NO. 2, PANEL, GAUGE NO. 1
15	AMP1	30 A	Audio system
16	EFI MAIN	30 A	Multiport fuel injection system/ sequential multiport fuel injection system, EFI NO. 1, EFI NO. 2
17	AMP2	30 A	Audio system
18	IG2	30 A	Starter system, IGN, GAUGE NO. 2, ECU IG2
19	IP JB	25 A	Power door lock system
20	STR LOCK	20 A	Starter system
21	RAD NO. 3	15 A	Meters and gauges lights, instrument panel lights, navigation system, audio system, rear seat entertainment system
22	HAZ	15 A	Emergency flashers

Fuse		Ampere	Circuit
23	ETCS	10 A	Multiport fuel injection system/ sequential multiport fuel injection system
24	RAD NO.1	10 A	Audio system
25	AM2	7.5 A	Starting system
26	ECU-B NO. 2	7.5 A	Air conditioning system, front passenger occupant classification system, starter system
27	MAYDAY/TEL	7.5 A	Mayday system
28	IMMOBI	7.5 A	————
29	ALT-S	7.5 A	Charging system
30	IGN	10 A	Starter system, multiport fuel injection system/sequential multiport fuel injection system
31	DOME	10 A	Vanity mirror lights, luggage compartment lights, interior lights, personal lights
32	ECU-B NO. 1	7.5 A	Interior lights, personal lights, tilt and telescopic steering, multiplex communication system, meters and gauges, power window, driving position memory system, power seats, power back door, head-up display, starter system, air conditioning system, power door lock system
33	EFI NO. 1	10 A	Multiport fuel injection system/ sequential multiport fuel injection system
34	WIP-S	7.5 A	Windshield wipers and washer

### 4-3. Do-it-yourself maintenance

Fuse		Ampere	Circuit
35	AFS	7.5 A	Adaptive front-lighting system
36	BK/UP LP	7.5 A	Back-up lights
37	HEATER NO. 2	7.5 A	Air conditioning system, AWD system
38	ECU IG1	10 A	Adaptive front-lighting system, headlight cleaner, cooling fan, cruise control, vehicle stability control, vehicle dynamics integrated management
39	EFI NO. 2	10 A	Multiport fuel injection system/ sequential multiport fuel injection system
40	F/PUMP	15 A	Multiport fuel injection system/ sequential multiport fuel injection system
41	DEICER	25 A	Windshield wipers and washer
42	STOP	7.5 A	Vehicle stability control, vehicle dynamics integrated management, high mounted stoplight
43	TOWING BATT	20 A	Trailer battery
44	TOWING	30 A	Trailer lights
45	FILTER	10 A	Condenser
46	IG1 MAIN	30 A	ECU IG1, BK/UP LP, HEATER NO. 2, AFS
47	H-LP RH HI	15 A	Right-hand headlight (high beam)
48	H-LP LH HI	15 A	Left-hand headlight (high beam)
49	BIXENON	10 A	Discharge headlight
50	H-LP RH LO	15 A	Right-hand headlight (low beam)
51	H-LP LH LO	15 A	Left-hand headlight (low beam)

	Fuse	Ampere	Circuit
52	HORN	10 A	Horn
53	A/F	20 A	Multiport fuel injection system/ sequential multiport fuel injection system
54	S-HORN	7.5 A	Security horn

#### n Driver's side instrument panel

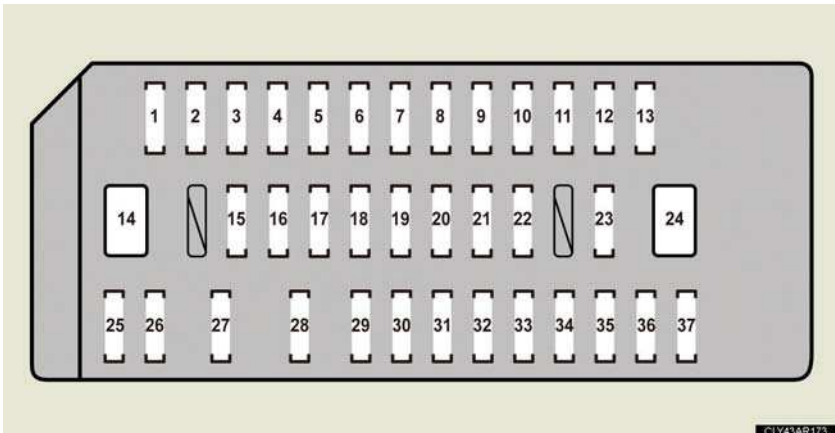

	Fuse	Ampere	Circuit
1	P/POINT	15 A	Power outlet
2	ECU-ACC	10 A	Navigation system, outside rear view mirror, multiplex communication system, multi-information display, head-up display
3	CIG	15 A	Power outlet
4	RADIO NO.2	7.5 A	Audio system, power outlet
5	GAUGE NO.1	10 A	Emergency flashers, navigation system, head-up display

Fuse		Ampere	Circuit
6	ECU-IG1 NO.3	10 A	Outside rear view mirror, windshield wipers and washer, seat heaters, starter system, power outlet, moon roof, Automatic High Beam
7	ECU-IG1 NO.1	10 A	Multiplex communication system, electric power steering system, shift lock control system, tilt and telescopic steering, starter system, automatic transmission system, power back door, tire pressure warning system
8	S/ROOF	30 A	Moon roof
9	FUEL OPN	7.5 A	Fuel filler door opener
10	PSB	30 A	Pre-collision seat belt
11	TI & TE	30 A	Tilt and telescopic steering system
12	DR LOCK	10 A	Power door lock system
13	FR FOG	15 A	Front fog lights
14	P-SEAT LH	30 A	Power seat (left-side)
15	4WD	7.5 A	AWD system
16	INVERTER	20 A	_____
17	RR FOG	7.5 A	_____
18	D/L ALT B	25 A	Multiplex communication system
19	HEATER	10 A	Air conditioning system
20	ECU-IG1 NO.2	10 A	Air conditioning system, multiport fuel injection system/sequential multiport fuel injection system, SRS airbag system, multi-information display



Fuse		Ampere	Circuit
21	PANEL	10 A	Switch illumination, navigation system, headlight cleaner, windshield wiper de-icer, seat heater, power back door, audio system, multi-information display, air conditioning system
22	TAIL	10 A	Parking lights, side marker lights, tail lights, license plate lights, front fog lights, towing converter
23	AIR SUS	20 A	————
24	P-SEAT RH	30 A	Power seat (right-side)
25	OBD	7.5 A	On-Board diagnosis
26	FR DOOR	25 A	Front power window (right-side)
27	RR DOOR	25 A	Rear power window (right-side)
28	FL DOOR	25 A	Front power window (left-side)
29	RL DOOR	25 A	Rear power window (left-side)
30	FR WASH	25 A	Windshield wipers and washer
31	RR WIP	15 A	Windshield wipers and washer
32	RR WASH	20 A	Windshield wipers and washer
33	FR WIP	30 A	Windshield wipers and washer
34	ECU IG2	10 A	Starter system, Intuitive parking assist, AWD system
35	GAUGE NO. 2	7.5 A	Starter system
36	RH S-HTR	15 A	Seat heater (right-side)
37	LH S-HTR	15 A	Seat heater (left-side)

### n After a fuse is replaced

- 1 If the lights do not turn on even after the fuse has been replaced, a bulb may need replacement. (→P. 511)
- 1 If the replaced fuse blows again, have the vehicle inspected by your Lexus dealer.

### n If there is an overload in the circuit

The fuses are designed to blow, protecting the wiring harness from damage.

### CAUTION

#### n To prevent system breakdowns and vehicle fire

Observe the following precautions.

Failing to do so may cause damage, and possibly a fire or injury.

- 1 Never use a fuse of a higher amperage rating than indicated, or use any other object in place of a fuse.
- 1 Always use a genuine Lexus fuse or equivalent.  
Never replace a fuse with a wire, even as a temporary fix.  
This can cause extensive damage or even fire.
- 1 Do not modify fuse or fuse boxes.

### NOTICE

#### n Before replacing fuses

Have the cause of electrical overload determined and repaired by your Lexus dealer.

## 4-3. Do-it-yourself maintenance

# Headlight aim (discharge headlights)

### n Vertical movement adjustment bolts

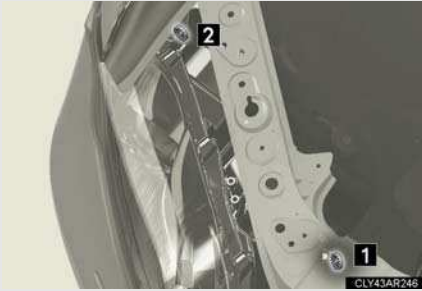

1 Adjustment bolt A

2 Adjustment bolt B

### n Before checking the headlight aim

**STEP 1** Remove the engine compartment cover. (→P. 464)

**STEP 2** Make sure the vehicle has a full tank of gas and the area around the headlight is not deformed.

**STEP 3** Park the vehicle on level ground.

**STEP 4** Sit in the driver's seat.

**STEP 5** Bounce the vehicle several times.

### n Adjusting the headlight aim

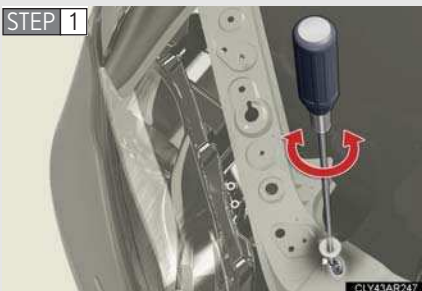

Turn bolt A in either direction using a Phillips-head screwdriver.

Remember the turning direction and the number of turns.

STEP 2

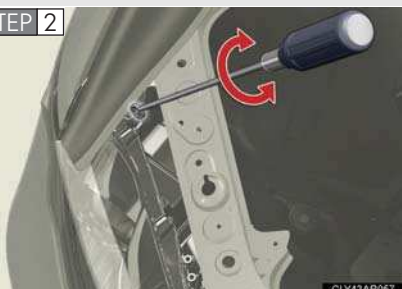

Turn bolt B the same number of turns and in the same direction as in step 1 using a Phillips-head screwdriver.

If the headlight cannot be adjusted using this procedure, take the vehicle to your Lexus dealer to adjust the headlight aim.

## 4-3. Do-it-yourself maintenance

# Light bulbs

You may replace the following bulbs by yourself. The difficulty level of replacement varies depending on the bulb. If necessary bulb replacement seems difficult to perform, contact your Lexus dealer.

For more information about replacing other light bulbs, contact your Lexus dealer.

### n Preparing for light bulb replacement

Check the wattage of the light bulb to be replaced. (→P. 605)

### n Removing the engine compartment covers

→P. 464

### n Turning off the power back door main switch (if equipped)

→P. 52

### n Front bulb locations

#### ▶ Discharge headlights



► Halogen headlights



n Rear bulb locations

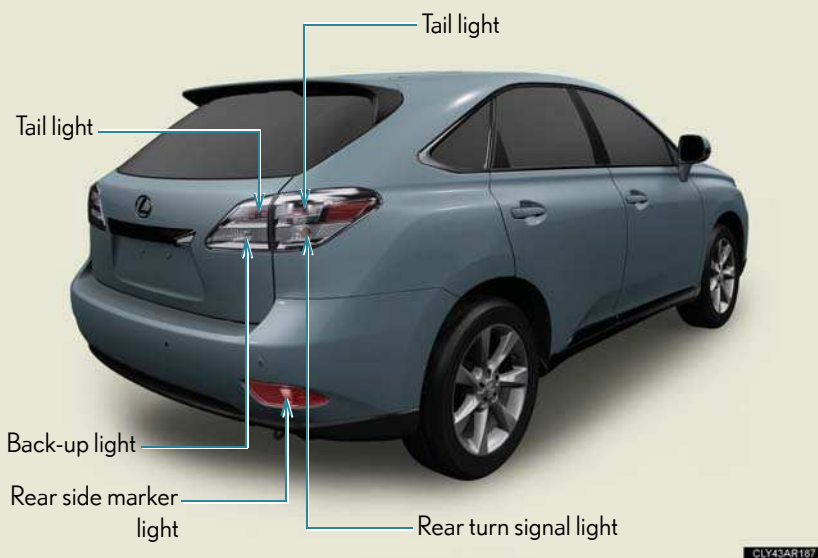

## Replacing light bulbs

### n Daytime running lights (discharge headlights)

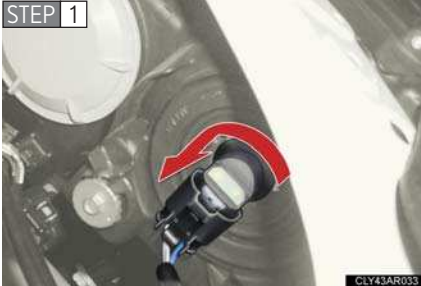

Turn the bulb base counterclockwise.

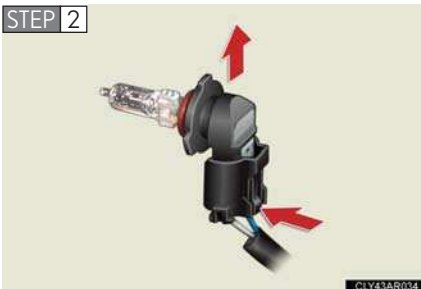

Unplug the connector while depressing the lock release.

### n Headlight high beams and daytime running lights (halogen headlights)



Right side only:

- 1** Open the cap.
- 2** Move the washer fluid filler opening to allow easy access to the light bulbs.

STEP 2

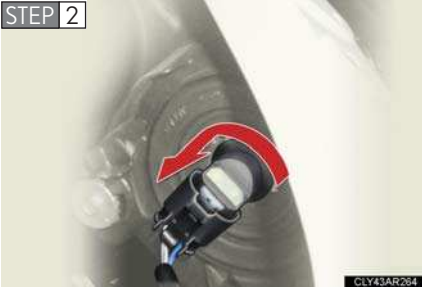

Turn the bulb base counterclockwise.

STEP 3

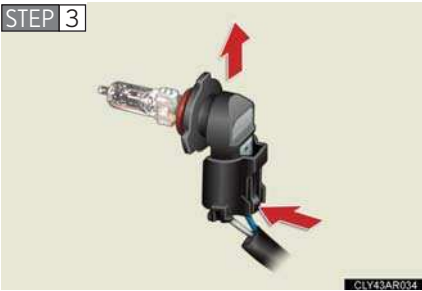

Unplug the connector while depressing the lock release.

### n Headlight low beams (halogen headlights)

STEP 1

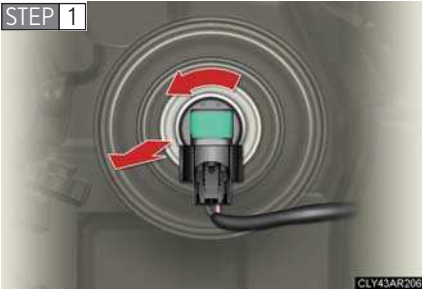

Turn the bulb base counterclockwise.

STEP 2

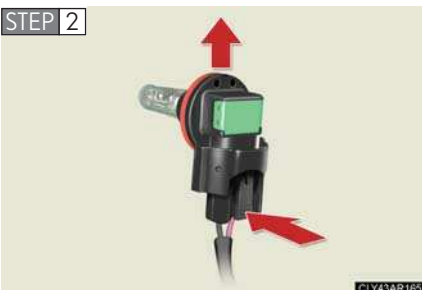

Unplug the connector while pressing the lock release.



## n Parking lights



Right side only:

- 1 Open the cap.
- 2 Move the washer fluid filler opening to allow easy access to the light bulbs.



Turn the bulb base counterclockwise.

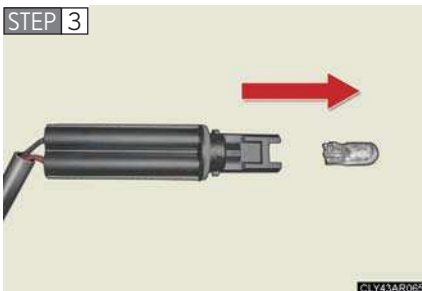

Remove the light bulb.

## n Front turn signal lights

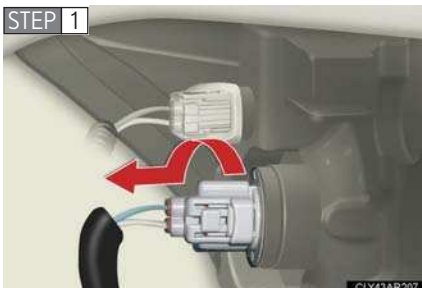

Turn the bulb base counterclockwise.

STEP 2

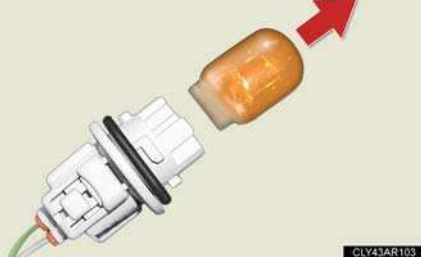

Remove the light bulb.

### n Front side marker lights

STEP 1

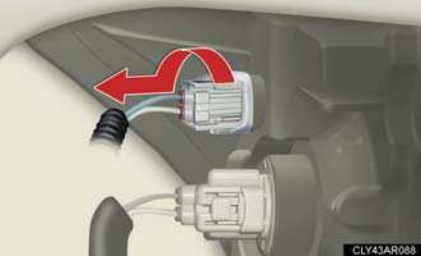

Turn the bulb base counterclockwise.

STEP 2



Remove the light bulb.

### n Rear turn signal and tail lights

STEP 1



Remove the access hole cover.

Use a flathead screwdriver wrapped in a cloth.

## STEP 2

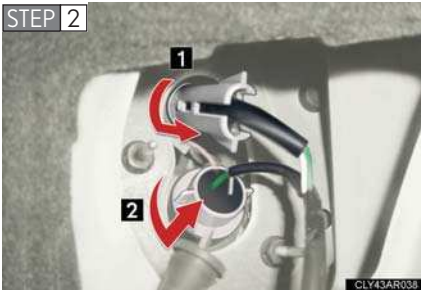

Turn the bulb base counterclockwise.

- 1 Tail light
- 2 Rear turn signal light

## STEP 3

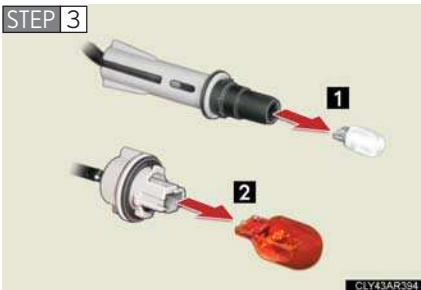

Remove the light bulb.

- 1 Tail light
- 2 Rear turn signal light

n Rear side marker lights (right side)

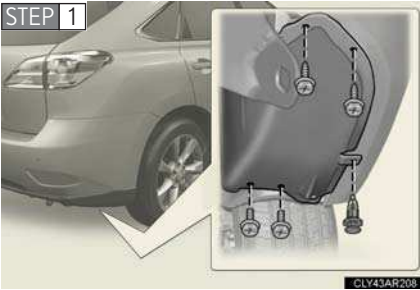

Remove the bolts using a Phillips-head screwdriver, and remove the clip.

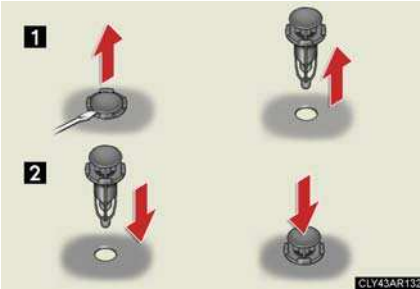

- 1 Removing the clip
- 2 Installing the clip



Turn the bulb base counterclockwise.



Remove the light bulb.

**n** Rear side marker lights (left side)

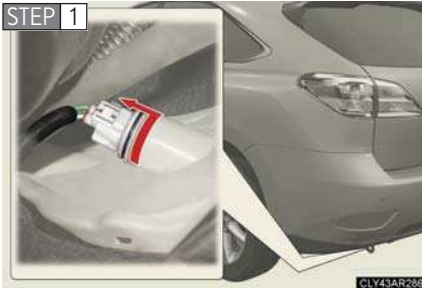

Turn the bulb base counterclockwise.



Remove the light bulb.

**n** Tail and back-up lights

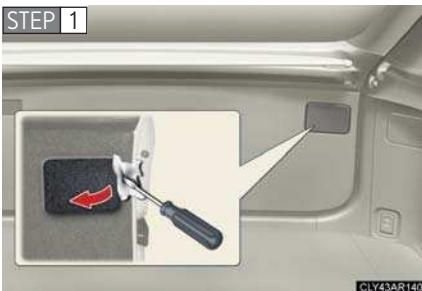

Remove the access hole cover.

Use a flathead screwdriver wrapped in a cloth.

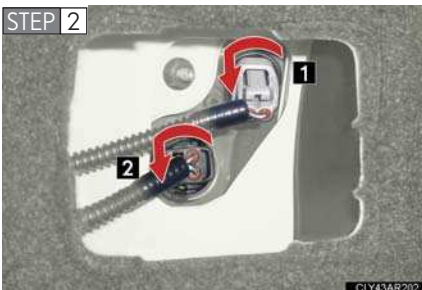

Turn the bulb base counterclockwise.

- 1** Tail light
- 2** Back-up light

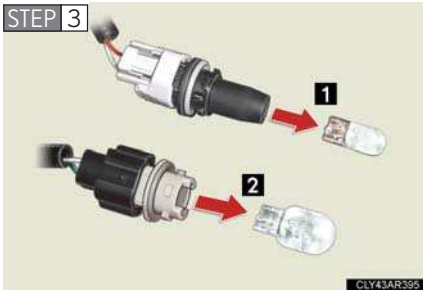

Remove the light bulb.

- 1 Tail light
- 2 Back-up light

**n Lights other than the above**

If any of the lights listed below has burnt out, have it replaced by your Lexus dealer.

- 1 Headlight low beams (discharge bulbs)
- 1 Headlight high and low beams (discharge bulbs)
- 1 Front fog lights
- 1 Side turn signal lights
- 1 Stop lights
- 1 High mounted stoplight
- 1 License plate lights

---

#### n **Discharge headlights (if equipped)**

If voltage to the discharge bulbs is insufficient, the bulbs may not come on, or may go out temporarily. The discharge bulbs will come on when normal power is restored.

#### n **LED bulbs**

The stop lights, side turn signal lights, license plate lights and high mounted stoplight consist of a number of LEDs. If any of the LEDs burn out, take your vehicle to your Lexus dealer to have the light replaced.

#### n **Condensation build-up on the inside of the lens**

Contact your Lexus dealer for more information in the following situations. Temporary condensation build-up on the inside of the headlight lens does not indicate a malfunction.

- 1 Large drops of water are built up on the inside of the lens.
- 1 Water has built up inside the headlight.

 **CAUTION**

**n Replacing light bulbs**

- 1** Turn off the lights. Do not attempt to replace the bulb immediately after turning off the lights.  
The bulbs become very hot and may cause burns.
- 1** Do not touch the glass portion of the light bulb with bare hands. Hold the bulb by the plastic or metal portion.  
If the bulb is scratched or dropped it may blow out or crack.
- 1** Fully install light bulbs and any parts used to secure them. Failing to do so may result in heat damage, fire, or water entering the headlight unit. This may damage the headlights or cause condensation to build up on the lens.

**n Discharge headlights (if equipped)**

- 1** Contact your Lexus dealer before replacing discharge headlights (including light bulbs).
- 1** Do not touch the discharge headlight's high voltage socket when the headlights are turned on.  
An extremely high voltage of 20000 V will be discharged and could result in serious injury or death by electric shock.
- 1** Do not attempt to take apart or repair the low beam discharge headlight bulbs, connectors, power supply circuits, or related components.  
Doing so could result in electric shock and serious injury or death.

**n To prevent damage or fire**

Make sure bulbs are fully seated and locked.



## 5-1. Essential information

# Emergency flashers

Use the emergency flashers if the vehicle malfunctions or is involved in an accident.

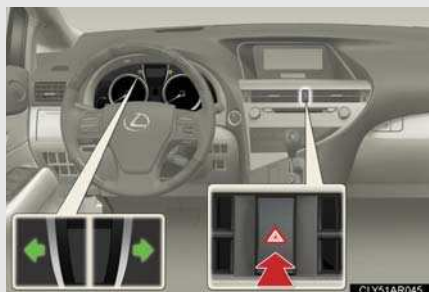

Press the switch to flash all the turn signal lights. To turn them off, press the switch once again.

### NOTICE

#### **n To prevent battery discharge**

Do not leave the emergency flashers on longer than necessary when the engine is not running.

## 5-1. Essential information

# If your vehicle needs to be towed

If towing is necessary, we recommend having your vehicle towed by your Lexus dealer or a commercial towing service, using a lift-type truck or a flatbed truck.

Use a safety chain system for all towing, and abide by all state/provincial and local laws.

2WD models: If towing your vehicle with a wheel-lift type truck from the front, the vehicle's rear wheels and axles must be in good conditions.

(→P. 527, 530)

If they are damaged, use a towing dolly or flatbed truck.

AWD models: If towing your vehicle with a wheel-lift type truck, use a towing dolly. (→P. 527, 530)

### Before towing

The following may indicate a problem with your transmission. Contact your Lexus dealer before towing.

- 1 The engine is running, but the vehicle will not move.
- 1 The vehicle makes an abnormal sound.

## Emergency towing



If a tow truck is not available in an emergency, your vehicle may be temporarily towed using a cable or chain secured to the emergency towing eyelet(s). This should only be attempted on hard, surfaced roads for short distances at low speeds.

A driver must be in the vehicle to steer and operate the brakes. The vehicle's wheels, drive train, axles, steering and brakes must be in good condition.

## Installing towing eyelets

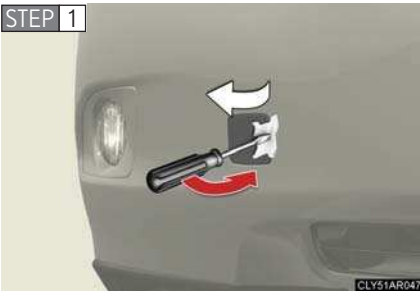

Remove the eyelet cover using a flathead screwdriver.

To protect the bodywork, place a rag between the screwdriver and the vehicle body, as shown in the illustration.

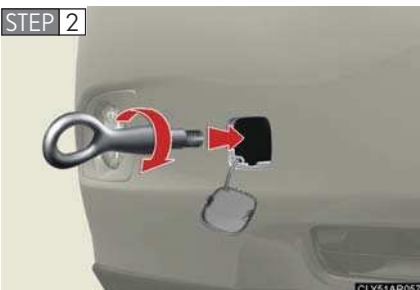

Insert the towing eyelet into the hole and tighten partially by hand.

STEP 3

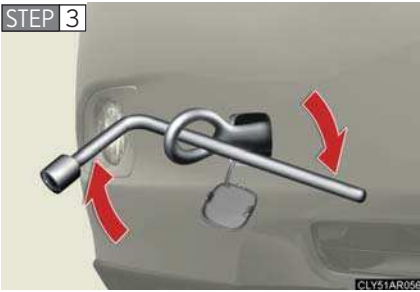

Tighten down the towing eyelet securely using a wheel nut wrench.

### Towing with a sling-type truck



Do not tow with a sling-type truck to prevent body damage.

### Towing with a wheel-lift type truck

► From the front (2WD models)

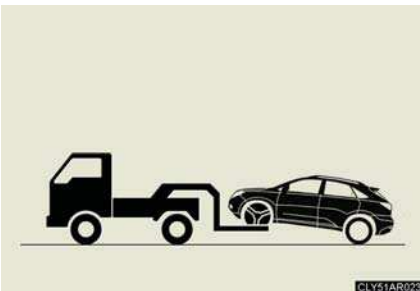

Release the parking brake.

► From the front (AWD models)

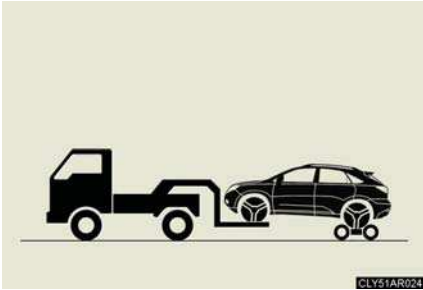

Use a towing dolly under the rear wheels.

► From the rear

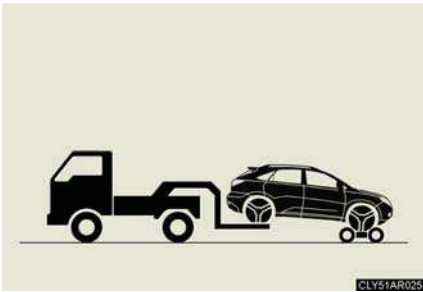

Use a towing dolly under the front wheels.

### Using a flatbed truck

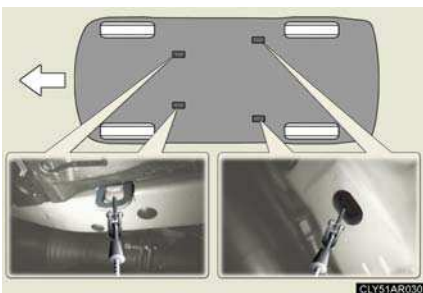

If your Lexus is transported by a flatbed truck, it should be tied down at the locations shown in the illustration.



If you use chains or cables to tie down your vehicle, the angles shaded in black must be 45°.

Do not overly tighten the tie downs or the vehicle may be damaged.

### n Before emergency towing

**STEP 1** Release the parking brake.

**STEP 2** Shift the shift lever to N.

**STEP 3** Turn the “ENGINE START STOP” switch to ACCESSORY (engine off) or IGNITION ON (engine running) mode.

### n Location of the emergency towing eyelet

→P.565

## ⚠ CAUTION

### n Caution while towing

**I** Use extreme caution when towing the vehicle.

Avoid sudden starts or erratic driving maneuvers which place excessive stress on the emergency towing eyelets and the cables or chains. Always be cautious of the surroundings and other vehicles while towing.

**I** If the engine is not running, the power assist for the brakes and steering will not function, making steering and braking more difficult.

### n Installing towing eyelets to the vehicle

Make sure that towing eyelets are installed securely.

If not securely installed, towing eyelets may come loose during towing. This may lead to accidents that cause serious injury or even death.

 NOTICE

**n To prevent body damage when towing with a sling-type truck**

Do not tow with a sling-type truck, either from the front or rear.

**n To prevent causing serious damage to the transmission and Active Torque Control 4WD system (AWD models) when towing using a wheel-lift type truck**



2WD models: Never tow this vehicle from the rear with the front wheels on the ground. This may cause serious damage to the transmission. If towing from the rear, use a towing dolly.

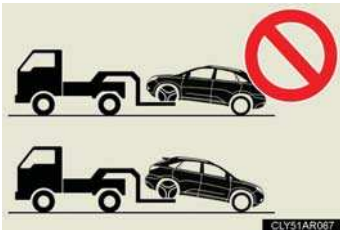

AWD models: Never tow this vehicle with any of the wheels on the ground. This may cause serious damage to the transmission and Active Torque Control 4WD system. Use a towing dolly.

**n To prevent damaging the vehicle when towing using a wheel-lift type truck**

When raising the vehicle, ensure adequate ground clearance for towing at the opposite end of the raised vehicle. Without adequate clearance, the vehicle could be damaged while being towed.

**n Recreational towing (behind motor home, etc.)**

Never dinghy tow your vehicle to prevent causing serious damage to the Active Torque Control 4WD system (AWD models) and transmission. (→P. 270)

# If you think something is wrong

If you notice any of the following symptoms, your vehicle probably needs adjustment or repair. Contact your Lexus dealer as soon as possible.

### **n** Visible symptoms

- 1 Fluid leaks under the vehicle.  
(Water dripping from the air conditioning after use is normal.)
- 1 Flat-looking tires or uneven tire wear
- 1 Engine coolant temperature gauge needle continually points higher than normal.

### **n** Audible symptoms

- 1 Changes in exhaust sound
- 1 Excessive tire squeal when cornering
- 1 Strange noises related to the suspension system
- 1 Pinging or other noises related to the engine

### **n** Operational symptoms

- 1 Engine missing, stumbling or running rough
- 1 Appreciable loss of power
- 1 Vehicle pulls heavily to one side when braking
- 1 Vehicle pulls heavily to one side when driving on a level road
- 1 Loss of brake effectiveness, spongy feeling, pedal almost touches the floor



## 5-1. Essential information

# Fuel pump shut off system

To minimize the risk of fuel leakage when the engine stalls or when an air-bag inflates upon collision, the fuel pump shut off system stops the supply of fuel to the engine.

Follow the procedure below to restart the engine after the system is activated.

**STEP 1** Turn the “ENGINE START STOP” switch to ACCESSORY mode or turn it off.

**STEP 2** Restart the engine.

### NOTICE

#### **n Before starting the engine**

Inspect the ground under the vehicle.

If you find that fuel has leaked onto the ground, the fuel system has been damaged and is in need of repair. Do not restart the engine.

## 5-1. Essential information

# Event data recorder

Your vehicle has computers that monitor and control certain aspects of your vehicle. These computers assist in driving and maintaining optimal vehicle performance.

Besides storing data useful for troubleshooting, there is an event data recorder (EDR) that records data in a crash or near crash event.

### In a crash or a near crash event

The SRS airbag sensor assembly contains the EDR. In a crash or near crash event, this device may record some or all of the following information:

- 1 Engine speed
- 1 Whether the brake pedal was applied or not
- 1 Vehicle speed
- 1 To what extent the accelerator pedal was depressed
- 1 Position of the transmission shift lever
- 1 Whether the driver and front passenger wore seat belts or not
- 1 Driver's seat position
- 1 SRS airbag deployment data
- 1 SRS airbag system diagnostic data
- 1 Front passenger's occupant classification

The information above is intended to be used for the purpose of improving vehicle safety performance. Unlike general data recorders, the EDR does not record sound data such as conversation between passengers.

## Disclosure of the data

Lexus will not disclose the data recorded in an EDR to a third party except when:

- I An agreement from the vehicle's owner (or the leasing company for a leased vehicle) is obtained
- I Officially requested to by the police or other authorities
- I Necessary, for use as a defense for Lexus in a law suit
- I Ordered to by a court of law

However, if necessary Lexus will:

- I Use the data for research on Lexus vehicle safety performance
- I Disclose the data to a third party for research purposes without disclosing details of the vehicle owner, and that only when deemed necessary
- I Disclose summarized data cleared of vehicle identification information to a non-Lexus organization for research purposes



## 5-2. Steps to take in an emergency

### If a warning light turns on or a warning buzzer sounds...

Calmly perform the following actions if any of the warning lights comes on or flashes. If a light comes on or flashes, but then goes off, this does not necessarily indicate a malfunction in the system.

**Stop the vehicle immediately. Continuing to drive the vehicle may be dangerous.**

The following warning indicates a possible problem in the brake system. Immediately stop the vehicle in a safe place and contact your Lexus dealer.

Warning light	Warning light/Details
 (U.S.A.)  (Canada)	<b>Brake system warning light (warning buzzer)*</b> <ul style="list-style-type: none"><li>• Low brake fluid</li><li>• Malfunction in the brake system</li></ul> This light also comes on when the parking brake is not released. If the light turns off after the parking brake is fully released the system is operating normally.

\*: Parking brake engaged warning buzzer

→P. 551









**Stop the vehicle immediately.**

The following warning indicates the possibility of damage to the vehicle that may lead to an accident. Immediately stop the vehicle in a safe place and contact your Lexus dealer.

Warning light	Warning light/Details
	<b>Charging system warning light</b> Indicates a malfunction in the vehicle's charging system





**Have the vehicle inspected by your Lexus dealer immediately.**

Failing to investigate the cause of the following warnings may lead to the system operating abnormally and possibly cause an accident. Have the vehicle inspected by your Lexus dealer immediately.

Warning light	Warning light/Details
 (U.S.A.)  (Canada)	<p><b>Malfunction indicator lamp</b></p> <p>Indicates a malfunction in:</p> <ul style="list-style-type: none"> <li>• The electronic engine control system;</li> <li>• The electronic throttle control system; or</li> <li>• The electronic automatic transmission control system</li> </ul>
	<p><b>SRS warning light</b></p> <p>Indicates a malfunction in:</p> <ul style="list-style-type: none"> <li>• The SRS airbag system;</li> <li>• The front passenger occupant classification system; or</li> <li>• The seat belt pretensioner system</li> </ul>
 (U.S.A.)  (Canada)	<p><b>ABS warning light</b></p> <p>Indicates a malfunction in:</p> <ul style="list-style-type: none"> <li>• The ABS; or</li> <li>• The brake assist system</li> </ul>
	<p><b>Electric power steering system warning light</b></p> <p>Indicates a malfunction in the EPS (Electric Power Steering) system</p>
	<p><b>Pre-collision system warning light (if equipped)</b></p> <p>Indicates a malfunction in the pre-collision system</p>
	<p><b>Slip indicator</b></p> <p>Indicates a malfunction in:</p> <ul style="list-style-type: none"> <li>• The VSC system;</li> <li>• The TRAC system; or</li> <li>• The hill-start assist control system</li> </ul>

### Follow the correction procedures.

After taking the specified steps to correct the suspected problem, check that the warning light goes off.

Warning light	Warning light/Details	Correction procedure
	<b>Open door warning light (warning buzzer)*<sup>1</sup></b> Indicates that one or more of the doors is not fully closed.	Check that all the doors are closed.
	<b>Low fuel level warning light</b> Indicates remaining fuel is approximately 2.8 gal. (10.7 L, 2.4 Imp. gal.) or less	Refuel the vehicle.
 (On the instrument panel)	<b>Driver's seat belt reminder light (warning buzzer)*<sup>2</sup></b> Warns the driver to fasten his/her seat belt.	Fasten the seat belt.
 (On the center panel)	<b>Front passenger's seat belt reminder light (warning buzzer)*<sup>2</sup></b> Warns the front passenger to fasten his/her seat belt.	Fasten the seat belt.
	<b>Master warning light</b> A buzzer sounds and the warning light comes on and flashes to indicate that the master warning system has detected a malfunction.	→P. 545

## 5-2. Steps to take in an emergency

Warning light	Warning light/Details	Correction procedure
	<b>Tire pressure warning light</b>	
	When the light comes on: Low tire inflation pressure.	Adjust the tire inflation pressure.
	When the light comes on after flashing for 1 minute: Malfunction in the tire pressure warning system.	Have the system checked by your Lexus dealer.

### \*1: Open door warning buzzer:

The open door warning buzzer sounds to alert one or more of the doors is not fully closed (with the vehicle having reached a speed of 3 mph [5 km/h]).  
(→P. 551)

### \*2: Driver's and front passenger's seat belt buzzer:

The driver's and front passenger's seat belt buzzer sounds to alert the driver and front passenger that his or her seat belt is not fastened. The buzzer sounds intermittently for 10 seconds after the vehicle reaches a speed of 12 mph (20 km/h). Then, if the seat belt is still unfastened, the buzzer will sound in a different tone for 20 more seconds.

### n **SRS warning light**

This warning light system monitors the airbag sensor assembly, front airbag sensors, side and curtain shield airbag sensors, curtain shield airbag sensors, driver's seat position sensor, driver's seat belt buckle switch, front passenger occupant classification system, "AIR BAG ON" indicator light, "AIR BAG OFF" indicator light, front passenger's seat belt buckle switch, seat belt pretensioner assemblies, inflators, interconnecting wiring and power sources. (→P.109)

### n **Front passenger detection sensor, passenger seat belt reminder and warning buzzer**

- 1 If luggage is placed on the front passenger seat, the front passenger detection sensor may cause the warning light to flash and the warning buzzer to sound even if a passenger is not sitting in the seat.
- 1 If a cushion is placed on the seat, the sensor may not detect a passenger, and the warning light may not operate properly.

### n **Electric power steering system warning light**

When the voltage is low or drops, the power steering warning light may come on.

### n **If the malfunction indicator lamp comes on while driving**

First check the following:

- 1 Is the fuel tank empty?  
If it is, fill the fuel tank immediately.
- 1 Is the fuel tank cap loose?  
If it is, tighten it securely.

The lamp will go off after several driving trips.

If the light does not go off even after several trips, contact your Lexus dealer as soon as possible.



### ■ **When the tire pressure warning light comes on**

Check the tire inflation pressure and adjust to the appropriate level. Pushing the tire pressure warning reset switch will not turn off the tire pressure warning light.

### ■ **The tire pressure warning light may come on due to natural causes**

The tire pressure warning light may come on due to natural causes such as natural air leaks and tire inflation pressure changes caused by temperature. In this case, adjusting the tire inflation pressure will turn off the warning light (after a few minutes).

### ■ **When a tire is replaced with a spare tire**

#### ▶ Vehicles with a compact spare tire

The compact spare tire is not equipped with a tire pressure warning valve and transmitter. If a tire goes flat, the tire pressure warning light will not turn off even though the flat tire has been replaced with the spare tire. Replace the spare tire with the repaired tire and adjust the tire inflation pressure. The tire pressure warning light will go off after a few minutes.

#### ▶ Vehicles with a full-size spare tire

The spare tire is also equipped with the tire pressure warning valve and transmitter. The tire pressure warning light will turn on if the tire inflation pressure of the spare tire is low. If a tire goes flat, even though the flat tire is replaced with the spare tire, the tire pressure warning light does not turn off. Replace the spare tire with the repaired tire and adjust the proper tire inflation pressure. The tire pressure warning light will turn off after a few minutes.

**n If the tire pressure warning system is not functioning**

The tire pressure warning system will be disabled in the following conditions:  
(When the condition becomes normal, the system will work properly.)

- 1 If tires not equipped with tire pressure warning valves and transmitters are used
- 1 If the ID code on the tire pressure warning valves and transmitters is not registered in the tire pressure warning computer
- 1 If the tire pressure warning select switch is set to a different tire setting.
- 1 If the tire inflation pressure is 73 psi (500 kPa, 5.1 kgf/cm<sup>2</sup> or bar) or higher

The tire pressure warning system may be disabled in the following conditions:  
(When the condition becomes normal, the system will work properly.)

- 1 If electronic devices or facilities using similar radio wave frequencies are nearby
- 1 If a radio set at similar frequencies is in use in the vehicle
- 1 If a window tint that affects the radio wave signals is installed
- 1 If there is a lot of snow or ice on the vehicle, in particular around the wheels or wheel housings
- 1 If non-genuine Lexus wheels are used (Even if you use Lexus wheels, the tire pressure warning system may not work properly with some types of tires.)
- 1 If tire chains are used
- 1 If the full-size spare tire is in a location subject to poor radio wave signal reception.
- 1 If a large metallic object which can interfere with signal reception is put in the luggage compartment (vehicles with full-size spare tire).

**n If the tire pressure warning light comes on after flashing frequently for 1 minute**

If the tire pressure warning light comes on after flashing frequently for 1 minute when the "ENGINE START STOP" switch is turned to IGNITION ON mode, have it checked by your Lexus dealer.

**n Customization**

The vehicle speed linked seat belt reminder buzzer can be disabled.  
(Customizable features →P. 621)

 **CAUTION**

**n When the power steering warning light comes on**

The steering wheel may become extremely heavy.

If the steering wheel becomes heavier than usual when operating, hold firmly and operate it using more force than usual.

**n If the tire pressure warning light comes on**

Be sure to observe the following precautions. Failure to do so could cause loss of vehicle control and result in death or serious injury.

**I** Stop your vehicle in a safe place as soon as possible. Adjust the tire inflation pressure immediately.

**I** If the tire pressure warning light comes on even after tire inflation pressure adjustment, it is probable that you have a flat tire. Check the tires. If a tire is flat, change it with the spare tire and have the flat tire repaired by the nearest Lexus dealer.

**I** Avoid abrupt maneuvering and braking. If the vehicle tires deteriorate, you could lose control of the steering wheel or the brakes.

**n If a blowout or sudden air leakage should occur**

The tire pressure warning system may not activate immediately.

 **CAUTION****n Maintenance of the tires**

Each tire, including the spare (if provided), should be checked monthly when cold and inflated to the inflation pressure recommended by the vehicle manufacturer on the vehicle placard or tire inflation pressure label (tire and load information label). (If your vehicle has tires of a different size than the size indicated on the vehicle placard or tire inflation pressure label [tire and load information label], you should determine the proper tire inflation pressure for those tires.)

As an added safety feature, your vehicle has been equipped with a tire pressure monitoring system (TPMS-tire pressure warning system) that illuminates a low tire pressure telltale (tire pressure warning light) when one or more of your tires is significantly under-inflated. Accordingly, when the low tire pressure telltale (tire pressure warning light) illuminates, you should stop and check your tires as soon as possible, and inflate them to the proper pressure. Driving on a significantly under-inflated tire causes the tire to overheat and can lead to tire failure. Under-inflation also reduces fuel efficiency and tire tread life, and may affect the vehicle's handling and stopping ability.

Please note that the TPMS (tire pressure warning system) is not a substitute for proper tire maintenance, and it is the driver's responsibility to maintain correct tire pressure, even if under-inflation has not reached the level to trigger illumination of the TPMS low tire pressure telltale (tire pressure warning light).

Your vehicle has also been equipped with a TPMS (tire pressure warning system) malfunction indicator to indicate when the system is not operating properly. The TPMS (tire pressure warning system) malfunction indicator is combined with the low tire pressure telltale (tire pressure warning light). When the system detects a malfunction, the telltale will flash for approximately one minute and then remain continuously illuminated. This sequence will continue upon subsequent vehicle start-ups as long as the malfunction exists. When the malfunction indicator is illuminated, the system may not be able to detect or signal low tire pressure as intended.

TPMS (tire pressure warning system) malfunctions may occur for a variety of reasons, including the installation of replacement or alternate tires or wheels on the vehicle that prevent the TPMS (tire pressure warning system) from functioning properly. Always check the TPMS (tire pressure warning system) malfunction telltale after replacing one or more tires or wheels on your vehicle to ensure that the replacement or alternate tires and wheels allow the TPMS (tire pressure warning system) to continue to function properly.

 NOTICE

**n Precaution when installing a different tire**

When a tire of a different specification or maker is installed, the tire pressure warning system may not operate properly.

## 5-2. Steps to take in an emergency If a warning message is displayed

If a warning is shown on the multi-information display, stay calm and perform the following actions:



### 1 Master warning light

The master warning light also comes on or flashes in order to indicate that a message is currently being displayed on the multi-information display.

### 2 Multi-information display

If any of the warning lights comes on again after the following actions have been performed, contact your Lexus dealer.

**Stop the vehicle immediately. Continuing to drive the vehicle may be dangerous.**

The following warning indicates a possible problem in the brake system. Immediately stop the vehicle in a safe place and contact your Lexus dealer.

Warning message	Details
<b>BRAKE MALFUNCTION</b>	<b>Indicates the following:</b> <ul style="list-style-type: none"><li>• The brake fluid level is low; or,</li><li>• The brake system is malfunctioning.</li></ul> A buzzer also sounds.





**Stop the vehicle immediately.**

A buzzer sounds and a warning message is shown on the multi-information display. The following warning indicates the possibility of damage to the vehicle that may lead to an accident. Immediately stop the vehicle in a safe place and contact your Lexus dealer.





Warning message	Details
<div data-bbox="79 516 338 643" data-label="Image"> </div> <div data-bbox="160 646 253 680" data-label="Text"> <p>(U.S.A.)</p> </div> <div data-bbox="79 696 338 823" data-label="Image"> </div> <div data-bbox="152 828 262 862" data-label="Text"> <p>(Canada)</p> </div> <div data-bbox="79 881 174 943" data-label="Image"> </div>	<p><b>Indicates abnormal engine oil pressure</b>                      The warning light may come on if the engine oil pressure is too low.</p>
<div data-bbox="79 976 338 1102" data-label="Image"> </div> <div data-bbox="79 1118 174 1180" data-label="Image"> </div> <div data-bbox="176 1122 280 1156" data-label="Text"> <p>(Flashes)</p> </div> <div data-bbox="134 1182 278 1216" data-label="Text"> <p>(If equipped)</p> </div>	<p><b>Indicates the AWD system has overheated</b></p>





## Have the vehicle inspected by your Lexus dealer immediately.



A buzzer sounds and a warning message is shown on the multi-information display. Failure to investigate the cause of the following warnings may lead to the system operating abnormally and possibly cause an accident. Have the vehicle inspected by your Lexus dealer immediately.

Warning message	Details
<div data-bbox="110 513 370 646" style="background-color: black; color: white; padding: 5px; text-align: center;"> <b>CHECK AWD SYSTEM</b> </div> <div data-bbox="110 656 204 716" style="text-align: center;">  </div> <p data-bbox="165 719 306 751">(If equipped)</p>	<p data-bbox="397 613 876 646">Indicates a malfunction in the AWD system</p>
<div data-bbox="110 777 370 911" style="background-color: black; color: white; padding: 5px; text-align: center;"> <b>HIGH TRANSMISSION FLUID TEMP.</b> </div> <div data-bbox="110 920 204 980" style="text-align: center;">  </div>	<p data-bbox="397 846 969 911">Indicates that the automatic transmission fluid temperature is too high</p>
<div data-bbox="110 1010 370 1143" style="background-color: black; color: white; padding: 5px; text-align: center;"> <b>CHECK BRAKE LAMP SYSTEM</b> </div> <div data-bbox="110 1153 204 1213" style="text-align: center;">  </div>	<p data-bbox="397 1094 942 1127">Indicates a malfunction in the brake lights system</p>
<div data-bbox="110 1242 370 1375" style="background-color: black; color: white; padding: 5px; text-align: center;"> <b>CHECK STEERING LOCK SYSTEM</b> </div> <div data-bbox="110 1385 204 1445" style="text-align: center;">  </div>	<p data-bbox="397 1326 958 1359">Indicates a malfunction in the steering lock system</p>





Warning message	Details
<p><b>CHECK AFS SYSTEM</b></p> <p><b>AFS OFF</b> (Flashes)</p> <p> (If equipped)</p>	<p>Indicates a malfunction in the adaptive front lighting system</p>
<p><b>CHECK PCS SYSTEM</b></p> <p> (If equipped)</p>	<p>Indicates a malfunction in the pre-collision system</p>
<p> <b>CHECK SONAR</b></p> <p> (If equipped)</p>	<p>Indicates a malfunction in the intuitive parking assist The malfunctioning assist-sensor is flashing.</p>

Warning message	Details
<p><b>CHECK CRUISE CONTROL SYSTEM</b></p>  (Flashes) or  (Flashes)  (if equipped)	<p><b>Indicates a malfunction in the radar cruise control system</b></p> <p>Press the “ON-OFF” button once to deactivate the system, and then press the button again to reactivate the system.</p>
<p><b>CHECK HEADLIGHT LEVELING SYSTEM</b></p>  (if equipped)	<p><b>Indicates a malfunction in the automatic headlight leveling system</b></p>
<p><b>CHECK SRS SYSTEM AIRBAG</b></p> 	<p><b>Indicates a malfunction in:</b></p> <ul style="list-style-type: none"> <li>• The SRS airbag system;</li> <li>• The front passenger occupant classification system;</li> </ul> <p>or,</p> <ul style="list-style-type: none"> <li>• The seat belt pretensioner system</li> </ul>
<p><b>CHECK ABS</b></p>	<p><b>Indicates a malfunction in:</b></p> <ul style="list-style-type: none"> <li>• The ABS; or,</li> <li>• The brake assist system</li> </ul>

Warning message	Details
 <p><b>CHECK POWER STEERING SYSTEM</b></p> 	<p>Indicates a malfunction in the EPS (Electric Power Steering) system</p>

### Follow the correction procedures.

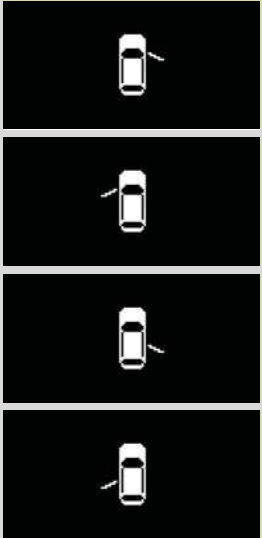
A buzzer sounds and a warning message is shown on the multi-information display. After taking the specified steps to correct the suspected problem, check that the warning message goes off.

Warning message	Details	Correction procedure
	<p><b>Indicates that one or more of the doors is not fully closed</b></p> <p>The system also indicates which doors are not fully closed.</p> <p>If the vehicle reaches a speed of 3 mph (5 km/h), a buzzer sounds to indicate that the door(s) are not yet fully closed.</p>	<p>Make sure that all the doors are closed.</p>
	<p><b>Indicates that the hood is not fully closed</b></p> <p>If the vehicle reaches a speed of 3 mph (5 km/h), a buzzer sounds to indicate that the hood is not yet fully closed.</p>	<p>Close the hood.</p>

## 5-2. Steps to take in an emergency

Warning message	Details	Correction procedure
 <p>BACK OPEN</p>	<p><b>Indicates that the back door is not fully closed</b></p> <p>If the vehicle reaches a speed of 3 mph (5 km/h), a buzzer sounds to indicate that the back door is not yet fully closed.</p>	<p>Close the back door.</p>
 <p>MOONROOF OPENED</p>  (Flashes) (If equipped)	<p><b>Indicates that the moon roof is not fully closed (with the "ENGINE START STOP" switch off, and the driver's door open)</b></p>	<p>Close the moon roof.</p>
 <p>RELEASE PARKING BRAKE</p>	<p><b>Indicates that the parking brake is still engaged</b></p> <p>If the vehicle reaches a speed of 3 mph (5 km/h),  flashes and a buzzer sounds to indicate that the parking brake is still engaged.</p>	<p>Release the parking brake.</p>
 <p>LOW WASHER FLUID</p>	<p><b>Indicates that the washer fluid level is low</b></p>	<p>Add washer fluid.</p>

Warning message	Details	Correction procedure
<p><b>OIL MAINTENANCE REQUIRED SOON</b></p> <p>(U.S.A. only)</p>	<p>Indicates that the engine oil is scheduled to be changed</p> <p>Comes on approximately 4500 miles (7200 km) after the engine oil is changed. (The indicator will not work properly unless the oil maintenance data has been reset.)</p>	<p>Check the engine oil, and change if necessary.</p>
<p><b>OIL MAINTENANCE REQUIRED</b></p> <p>(U.S.A. only)</p>	<p>Indicates that the engine oil and oil filter should be changed</p>	<p>Have the engine oil and oil filter checked and changed by your Lexus dealer.</p>
<p><b>AWD DISABLED</b></p> <p> (Flashes) (If equipped)</p>	<p>Indicates that the AWD system is not currently functional</p> <p>A buzzer also sounds.</p>	<p>Reduce vehicle speed or stop the vehicle in a safe place until the warnings clear.</p> <p>In this case, do not stop the engine.</p>
<p><b>PCS TEMPORARILY NOT AVAILABLE</b></p> <p>(If equipped)</p>	<p>Indicates that the pre-collision system is not currently functional</p>	<p>Clean the grille and the sensor.</p> <p>This message appears when the pre-collision system is hot. In this case, wait until the system cools down.</p>

5-2. Steps to take in an emergency





Warning message	Details	Correction procedure
  (If equipped)	<p>Indicates that intuitive parking assist is dirty or covered with ice</p> <p>A buzzer also sounds.</p>	<p>Clean the sensor.</p>
  (Flashes)  (If equipped)	<p>Indicates that the radar cruise control sensor is dirty or covered with ice</p> <p>A buzzer also sounds.</p>	<p>Clean the sensor.</p>
  (Flashes)  (If equipped)	<p>Indicates that the radar cruise control system is unable to judge vehicle-to-vehicle distance</p> <p>A buzzer also sounds.</p>	<p>If the windshield wipers are on, turn them off or set them to a mode other than "AUTO" or high speed wiper operation.</p>
 (Flashes) (If equipped)	<p>Indicates that your vehicle is nearing the vehicle ahead (in radar cruise mode)</p> <p>At the same time,</p>  will appear on the head-up display.	<p>Slow the vehicle by applying the brakes.</p>



Warning message	Details	Correction procedure
<p data-bbox="108 266 370 396"><b>ENGINE OVERHEAT</b></p> 	<p data-bbox="395 305 674 412">Indicates that the engine has overheated A buzzer also sounds.</p>	<p data-bbox="704 324 880 396">Stop and check. (→P. 587)</p>
<p data-bbox="108 490 370 620"><b>LOW FUEL</b></p>	<p data-bbox="395 483 674 623">Indicates that remaining fuel is approximately 2.8 gal. (10.7 L, 2.4 Imp. gal.) or less</p>	<p data-bbox="704 535 904 568">Refuel the vehicle.</p>



**Have the malfunction repaired immediately.**

After taking the specified steps to correct the suspected problem, check that the warning message and light go off.

Interior buzzer	Exterior buzzer	Warning message	Details	Correction procedure
Sounds once	—	  (Flashes)	The electronic key is not detected when an attempt is made to start the engine.	Confirm the location of the electronic key.
Sounds once	Sounds 3 times	  (Flashes)	The electronic key was carried outside the vehicle and a door other than the driver's door was opened and closed while the "ENGINE START STOP" switch was in a mode other than off.	Bring the electronic key back into the vehicle.
			The driver's door was opened and closed while the electronic key was not in the vehicle, the shift lever was in P and the "ENGINE START STOP" switch was not turned off.	Turn the "ENGINE START STOP" switch off or bring the electronic key back into the vehicle.





Interior buzzer	Exterior buzzer	Warning message	Details	Correction procedure
Sounds once	Sounds once	<p><b>KEY NOT DETECTED</b></p> <p><b>TURN POWER OFF</b></p> <p>(Displayed alternately)</p> <p> (Flashes)</p>	An attempt was made to exit the vehicle with the electronic key and lock the doors without first turning the “ENGINE START STOP” switch off.	Turn the “ENGINE START STOP” switch off and lock the doors again.
Sounds once	—	<p><b>KEY NOT DETECTED</b></p> <p> (Flashes)</p>	An attempt was made to start the engine without the electronic key being present, or the electronic key was not functioning normally. An attempt was made to drive when the regular key was not inside the vehicle.	Confirm that the electronic key is inside the vehicle.
Continuous	—	<p><b>SHIFT TO P RANGE</b></p> <p> (Flashes)</p>	The driver’s door was opened when the shift lever was not in P and the “ENGINE START STOP” switch was not turned off.	Shift the shift lever to P.





## 5-2. Steps to take in an emergency

Interior buzzer	Exterior buzzer	Warning message	Details	Correction procedure
Con- tinuous	Con- tinuous	<div data-bbox="253 305 512 435" style="background-color: black; color: white; padding: 5px; text-align: center;"> <b>SHIFT TO P RANGE</b> </div> <div data-bbox="253 441 512 571" style="background-color: black; color: white; padding: 5px; text-align: center;"> <b>KEY NOT DETECTED</b> </div> <p data-bbox="253 578 512 610">(Displayed alternately)</p> <div data-bbox="253 617 348 682" style="background-color: black; color: yellow; padding: 5px; text-align: center;">  </div> <p data-bbox="353 623 512 656">(Flashes)</p>	<p>The driver's door was opened and closed while the electronic key was not in the vehicle, the shift lever was not in P and the "ENGINE START STOP" switch was not turned off.</p>	<ul style="list-style-type: none"> <li>• Shift the shift lever to P.</li> <li>• Bring the electronic key back into the vehicle.</li> </ul>



Interior buzzer	Exterior buzzer	Warning message	Details	Correction procedure
Sounds once	Continuous	<div data-bbox="285 613 543 740" style="background-color: black; color: white; padding: 5px; text-align: center; font-weight: bold;">KEY DETECTED IN VEHICLE</div> <div data-bbox="285 753 378 813" style="display: inline-block; text-align: center;"></div> (Flashes)	<p>An attempt was made to lock the doors using the smart access system with push-button start while the electronic key was still inside the vehicle.</p> <p>An attempt was made to lock either front door by opening a door and putting the inside lock button into the lock position, then closing the door by pulling on the outside door handle with the electronic key still inside the vehicle.</p>	Retrieve the electronic key from the vehicle and lock the doors again.



## 5-2. Steps to take in an emergency

Interior buzzer	Exterior buzzer	Warning message	Details	Correction procedure
Sounds once	—	  (Flashes)	<ul style="list-style-type: none"> <li>• When the doors were unlocked with the mechanical key and then the “ENGINE START STOP” switch was pressed, the electronic key could not be detected in the vehicle.</li> <li>• The electronic key could not be detected in the vehicle even after the “ENGINE START STOP” switch was pressed two consecutive times.</li> </ul>	Touch the electronic key to the “ENGINE START STOP” switch while depressing the brake pedal.
Sounds once	—	  (Flashes)	An attempt was made to start the engine with the shift lever in an incorrect position.	Shift the shift lever to P and start the engine.

Interior buzzer	Exterior buzzer	Warning message	Details	Correction procedure
Sounds once	—	  (Flashes)	An attempt was made to turn the “ENGINE START STOP” switch off when the shift lever was not in P.	To turn off the engine, first shift the shift lever to P and then turn the “ENGINE START STOP” switch off.
—	—		Power was turned off due to the automatic power off function.	Next time when starting the engine, increase the engine speed slightly and maintain that level for approximately 5 minutes to recharge the battery.
Sounds once	—	 	The electronic key has a low battery.	Replace the electronic key battery. (→P. 496)

## 5-2. Steps to take in an emergency

Interior buzzer	Exterior buzzer	Warning message	Details	Correction procedure
Sounds once	—		<p>The driver's door was opened and closed with the "ENGINE START STOP" switch turned off and then the "ENGINE START STOP" switch was put in ACCESSORY mode twice without the engine being started.</p>	<p>Press the "ENGINE START STOP" switch while depressing the brake pedal.</p>
		 (Flashes)	<p>During an engine starting procedure in the event that the electronic key was not functioning properly (→P. 581), the "ENGINE START STOP" switch was touched with the electronic key.</p>	<p>Press the "ENGINE START STOP" switch within 10 seconds of the buzzer sounding.</p>

Interior buzzer	Exterior buzzer	Warning message	Details	Correction procedure
Sounds once	—	  (Flashes)	The steering lock could not be released within 3 seconds of the “ENGINE START STOP” switch being pressed.	Press the “ENGINE START STOP” switch while depressing the brake pedal and moving the steering wheel left and right.

#### n **Warning light display in radar cruise mode (if equipped)**

In the following cases, the warning light may not be displayed even if vehicle-to-vehicle distance decreases:

- 1 When your vehicle and the vehicle ahead are traveling at the same speed or the vehicle ahead is traveling more quickly than your vehicle
- 1 When the vehicle ahead is traveling at a very low speed
- 1 Immediately after cruise control speed is set
- 1 At the instant the accelerator pedal is depressed

#### n **After changing the engine oil (U.S.A. only)**

Make sure to reset the oil maintenance data. (→P. 466)



## 5-2. Steps to take in an emergency

### If you have a flat tire

Remove the flat tire and replace it with the spare provided.

#### n Before jacking up the vehicle

- 1 Stop the vehicle on a hard, flat surface.
- 1 Set the parking brake.
- 1 Shift the shift lever to P.
- 1 Stop the engine.
- 1 Turn on the emergency flashers.

**n Location of the spare tire, jack and tools**

► Vehicles with a compact spare tire

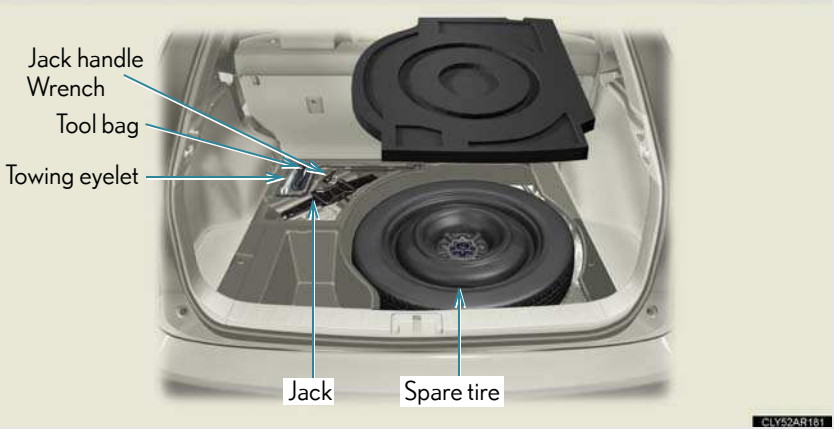

► Vehicles with a full-size spare tire

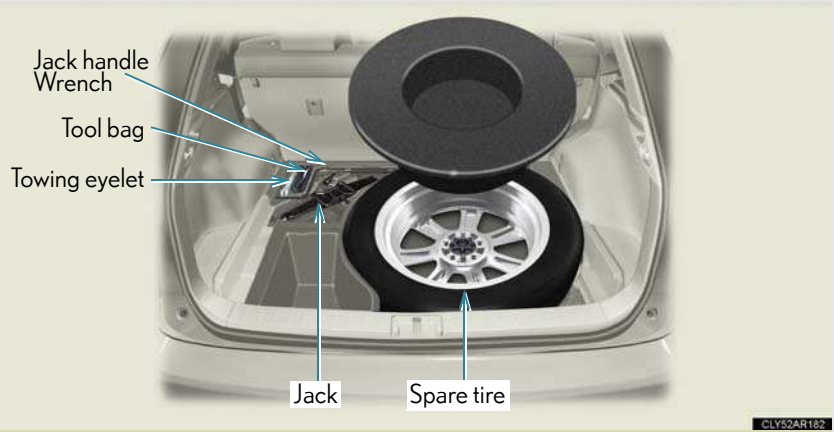

## Taking out the jack

► Vehicles with a compact spare tire



Pull the lever upward to fold back the front part of the deck board.

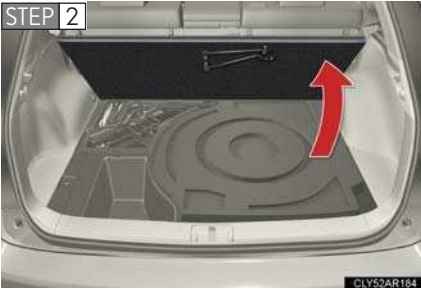

Pull the folded deck board upright.



Pull on the attached hook to extend the string.



Use the hook to secure the deck board as shown in the illustration.



Remove the jack after removing the hook.

► Vehicles with a full-size spare tire



Pull the lever upward to fold back the front part of the deck board.



Pull on the attached hook to extend the string.

## 5-2. Steps to take in an emergency



Pull the folded deck board upright, and use the hook to secure the deck board as shown in the illustration.



Remove the jack after removing the hook.

## Taking out the spare tire

**STEP 1** Lift up the deck board. (See “Taking out the jack” for details.)

**STEP 2** Remove the spare tire cover. (→P. 98)

**STEP 3** Loosen the center fastener that secures the spare tire.

▶ Vehicles with a compact spare tire



▶ Vehicles with a full-size spare tire



## Replacing a flat tire

STEP 1

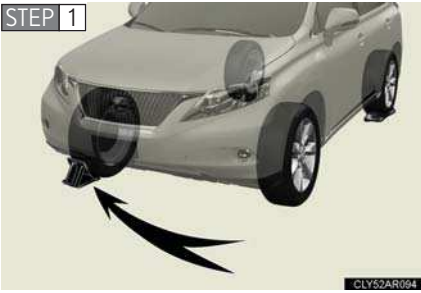

Chock the tires.

Flat tire		Wheel chock positions
Front	Left-hand side	Behind the rear right-hand side tire
	Right-hand side	Behind the rear left-hand side tire
Rear	Left-hand side	In front of the front right-hand side tire
	Right-hand side	In front of the front left-hand side tire

STEP 2

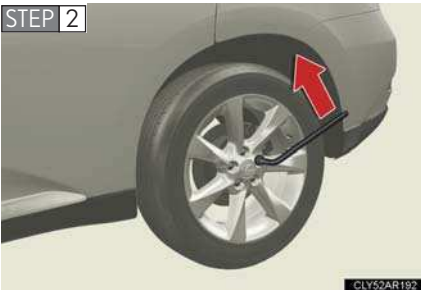

Slightly loosen the wheel nuts (one turn).

STEP 3



Turn the tire jack portion "A" by hand until the notch of the jack is in contact with the jack point.

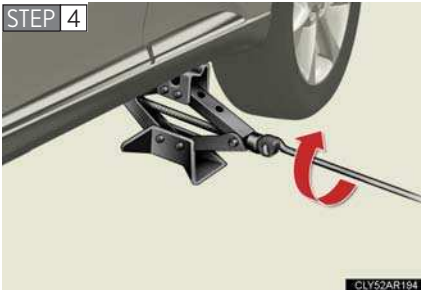

Raise the vehicle until the tire is slightly raised off the ground.



Remove all the wheel nuts and the tire.

When resting the tire on the ground, place the tire so that the wheel design faces up to avoid scratching the wheel surface.

### Installing the spare tire

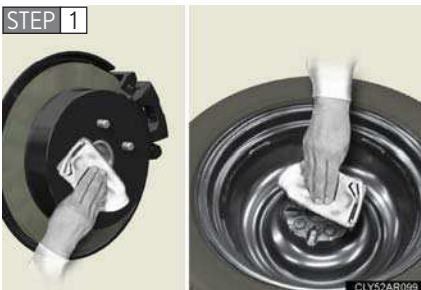

Remove any dirt or foreign matter from the wheel contact surface.

If foreign matter is on the wheel contact surface, the wheel nuts may loosen while the vehicle is in motion, causing the tire to come off.



## 5-2. Steps to take in an emergency

**STEP 2** Install the spare tire and loosely tighten each wheel nut by hand by approximately the same amount.

► Vehicles with a compact spare tire

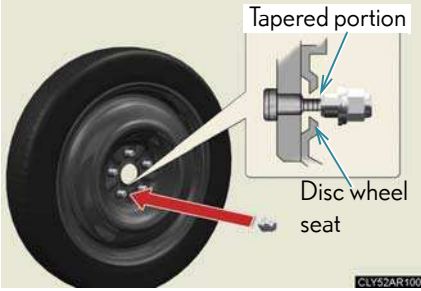

Tighten the nuts until the tapered portion comes into loose contact with the disc wheel seat.

► Vehicles with a full-size spare tire

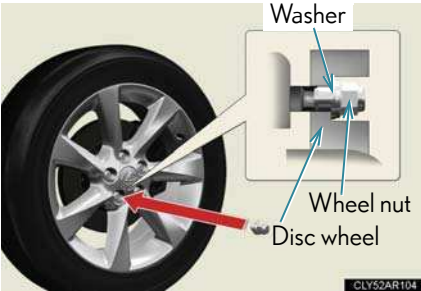

Turn the nuts until the washers come into contact with the wheel.

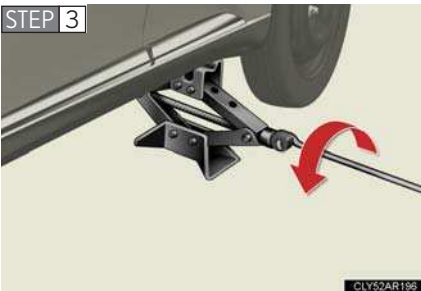

Lower the vehicle.

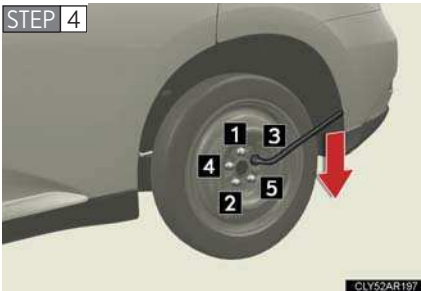

Firmly tighten each wheel nut two or three times in the order shown in the illustration.

**Tightening torque:**  
76 ft•lbf (103 N•m, 10.5 kgf•m)

**STEP 5** Stow the flat tire, tire jack and all tools.

#### n The compact spare tire

- 1 The compact spare tire is identified by the label "TEMPORARY USE ONLY" on the tire sidewall.  
Use the compact spare tire temporarily, and only in an emergency.
- 1 Make sure to check the tire inflation pressure of the compact spare tire.  
(→P. 602)

#### n When using the compact spare tire

As the compact spare tire is not equipped with a tire pressure warning valve and transmitter, low inflation pressure of the spare tire will not be indicated by the tire pressure warning system. Also, if you replace the compact spare tire after the tire pressure warning light comes on, the light remains on.

#### n If you have a flat front tire on a road covered with snow or ice

Install the compact spare tire on one of the rear wheels of the vehicle. Perform the following steps and fit tire chains to the front tires:

**STEP 1** Replace a rear tire with the compact spare tire.

**STEP 2** Replace the flat front tire with the tire removed from the rear of the vehicle.

**STEP 3** Fit tire chains to the front tires.

#### n After completing the tire change

The tire pressure warning system must be reset. (→P. 479)

 **CAUTION**

**n Using the tire jack**

Improper use of the tire jack may cause the vehicle to suddenly fall off the jack, leading to death or serious injury.

- 1** Do not use the tire jack for any purpose other than replacing tires or installing and removing tire chains.
- 1** Only use the tire jack that comes with this vehicle for replacing a flat tire. Do not use it on other vehicles, and do not use other tire jacks for replacing tires on this vehicle.
- 1** Always check that the tire jack is securely set to the jack point.
- 1** Do not put any part of your body under the vehicle is supported by the jack.
- 1** Do not start or run the engine while your vehicle while it is supported by the jack.
- 1** Do not raise the vehicle while someone is in it.
- 1** When raising the vehicle, do not put an object on or under the jack.
- 1** Do not raise the vehicle to a height greater than that required to replace the tire.
- 1** Use a jack stand if it is necessary to get under the vehicle.

Take particular care when lowering the vehicle to ensure that no one working on or near the vehicle may be injured.

**n Replacing a flat tire**

Observe the following precautions to reduce the risk of death or serious injury:

- 1** Do not touch the disc wheels or the area around the brakes immediately after the vehicle has been driven.  
After the vehicle has been driven the disc wheels and the area around the brakes will be extremely hot. Touching these areas with hands, feet or other body parts while changing a tire, etc. may result in burns.
- 1** Never use oil or grease on the wheel bolts or wheel nuts.  
Oil and grease may cause the wheel nuts to be excessively tightened, leading to bolt or disc wheel damage. In addition, the oil or grease can cause the wheel nuts to loosen and the wheel may fall off, causing a serious accident. Remove any oil or grease from the wheel bolts or wheel nuts.

**⚠ CAUTION**

**I** Have the wheel nuts tightened with a torque wrench to 76 ft•lbf (103 N•m, 10.5 kgf•m) as soon as possible after changing wheels.

Failure to follow these precautions could cause the nuts to loosen and the wheels may fall off, which could lead to an accident causing death or serious injury.

**I** When installing a tire, only use wheel nuts that have been specifically designed for that wheel.

**I** If there are any cracks or deformations in the bolt screws, nut threads or bolt holes of the wheel, have the vehicle inspected by your Lexus dealer.

Failure to follow these precautions could cause the wheel nuts to loosen and the tire to fall off, resulting in death or serious injury.

**n When using the compact spare tire**

**I** Remember that the compact spare tire provided is specifically designed for use with your vehicle. Do not use your compact spare tire on another vehicle.

**I** Do not use more than one compact spare tire simultaneously.

**I** Replace the compact spare tire with a standard tire as soon as possible.

**I** Avoid sudden acceleration, deceleration and braking, as well as sharp cornering.

**n When the compact spare tire is attached**

The vehicle speed may not be correctly detected, and the following systems may not operate correctly:

**I** ABS & Brake assist

**I** VSC

**I** Enhanced VSC

**I** TRAC

**I** VDIM

**I** Intuitive parking assist (if equipped)

**I** Navigation system (if equipped)

**I** Cruise control (if equipped)

**I** Dynamic radar cruise control (if equipped)

**I** Pre-Collision System (if equipped)

### CAUTION

Also, not only can the following system not be utilized fully, but it may even negatively affect the drive-train components:

I AWD system (if equipped)

#### **n Speed limit when using the compact spare tire**

Do not drive at speeds in excess of 50 mph (80 km/h) when a compact spare tire is installed on the vehicle.

The compact spare tire is not designed for driving at high speeds. Failure to observe this precaution may lead to an accident causing death or serious injury.

### NOTICE

#### **n Do not drive the vehicle with a flat tire**

Do not continue driving with a flat tire.

Driving even a short distance with a flat tire can damage the tire and the wheel beyond repair.

#### **n Be careful when driving over bumps with the compact spare tire installed on the vehicle.**

The vehicle becomes lower when driving with the compact spare tire compared to when driving with standard tires. Be careful when driving over uneven road surfaces.

#### **n Driving with tire chains and the compact spare tire**

Do not fit tire chains to the compact spare tire.

Tire chains may damage the vehicle body and adversely affect driving performance.

#### **n When replacing the tires**

When removing or fitting the wheels, tires or the tire pressure warning valve and transmitter, contact your Lexus dealer as the tire pressure warning valve and transmitter may be damaged if not handled correctly.

#### **n To avoid damage to the tire pressure warning valves and transmitters**

When a tire is repaired with liquid sealants, the tire pressure warning valve and transmitter may not operate properly. If a liquid sealant is used, contact your Lexus dealer or other qualified service shop as soon as possible. Make sure to replace the tire pressure warning valve and transmitter when replacing the tire. (→P. 479)

## 5-2. Steps to take in an emergency

### If the engine will not start

If the engine will not start even though correct starting procedures are being followed (→P. 153), consider each of the following points.

**n** The engine will not start, even though the starter motor operates normally.

One of the following may be the cause of the problem:

1 There may not be sufficient fuel in the vehicle's tank.

Refuel the vehicle.

1 The engine may be flooded.

Try to restart the engine again following correct starting procedures. (→P. 153)

1 There may be a malfunction in the engine immobilizer system.

(→P. 101)

**n** The starter motor turns over slowly, the interior lights and headlights are dim, or the horn does not sound or sounds at a low volume.

One of the following may be the cause of the problem:

1 The battery may be discharged. (→P. 584)

1 The battery terminal connections may be loose or corroded.

**n** The starter motor does not turn over.

The engine starting system may be malfunctioning due to an electrical problem such as an open circuit or a blown fuse. However, an interim measure is available to start the engine. (→P. 578)

**n The starter motor does not turn over, the interior lights and headlights do not turn on, or the horn does not sound.**

One of the following may be the cause of the problem:

- 1 One or both of the battery terminals may be disconnected.
- 1 The battery may be discharged. (→P. 584)
- 1 There may be a malfunction in the steering lock system.

Contact your Lexus dealer if the problem cannot be repaired, or if repair procedures are unknown.

## Emergency start function

When the engine does not start, the following steps can be used as an interim measure to start the engine if the “ENGINE START STOP” switch is functioning normally:

**STEP 1** Set the parking brake.

**STEP 2** Shift the shift lever to P.

**STEP 3** Turn the “ENGINE START STOP” switch to ACCESSORY mode.

**STEP 4** Press and hold the “ENGINE START STOP” switch for about 15 seconds while depressing the brake pedal firmly.

Even if the engine can be started using the above steps, the system may be malfunctioning. Have the vehicle inspected by your Lexus dealer.

## 5-2. Steps to take in an emergency

### If the shift lever cannot be shifted from P

If the shift lever cannot be shifted with your foot on the brake pedal, there may be a problem with the shift lock system (a system to prevent accidental operation of the shift lever). Have the vehicle inspected by your Lexus dealer immediately.

The following steps may be used as an emergency measure to ensure that the shift lever can be shifted:

**STEP 1** Set the parking brake.

**STEP 2** Turn the “ENGINE START STOP” switch to ACCESSORY mode.

**STEP 3** Depress the brake pedal.



Pry the cover up with a flathead screwdriver or equivalent.



Press the shift lock override button.

The shift lever can be shifted while the button is pressed.



## 5-2. Steps to take in an emergency

### If you lose your keys

New genuine Lexus keys can be made by your Lexus dealer using the other keys and the key number stamped on your key number plate.

## 5-2. Steps to take in an emergency

# If the electronic key does not operate properly

If communication between the electronic key and vehicle is interrupted (→P. 36) or the electronic key cannot be used because the battery is depleted, the smart access system with push-button start and wireless remote control cannot be used. In such cases, the doors can be opened or the engine can be started by following the procedure below.

### Locking and unlocking the doors and key linked functions

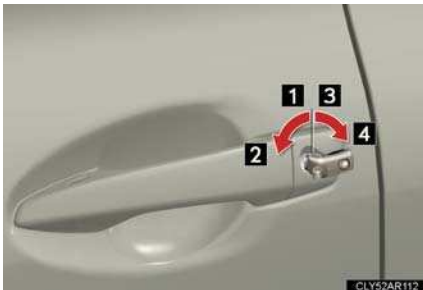

Use the mechanical key (→P. 27) in order to perform the following operations (driver's door only):

- 1 Locks all the doors
- 2 Closes the windows and moon roof (turn and hold)
- 3 Unlocks the door

Turning the key rearward unlocks the driver's door. Turning the key once again unlocks the other doors.

- 4 Opens the windows and moon roof (turn and hold)

## Changing “ENGINE START STOP” switch modes and starting the engine

**STEP 1** Ensure that the shift lever is in P and depress the brake pedal.



Touch the Lexus emblem side of the electronic key to the “ENGINE START STOP” switch.

If any of the doors is opened or closed while the key is being touched to the switch, an alarm will sound to indicate that the start function cannot detect the electronic key.



**STEP 3** To change “ENGINE START STOP” switch modes: Within 10 seconds of the buzzer sounding, release the brake pedal and press the “ENGINE START STOP” switch. Modes can be changed each time the switch is pressed. (→P. 154)

To start the engine: Press the “ENGINE START STOP” switch within 10 seconds of the buzzer sounding, keeping the brake pedal depressed.

In the event that the “ENGINE START STOP” switch still cannot be operated, contact your Lexus dealer.

---

n **Stopping the engine**

Shift the shift lever to P and press the “ENGINE START STOP” switch as you normally do when stopping the engine.

n **Replacing the key battery**

As the above procedure is a temporary measure, it is recommended that the electronic key battery be replaced immediately when the battery is depleted.  
(→P. 496)

## 5-2. Steps to take in an emergency If the battery is discharged

The following procedures may be used to start the engine if the vehicle's battery is discharged.

You can call your Lexus dealer or a qualified repair shop.

If you have a set of jumper (or booster) cables and a second vehicle with a 12-volt battery, you can jump start your vehicle by following the steps below.

**STEP 1** Open the hood. Remove the battery cover. (→P. 465)

**STEP 2**

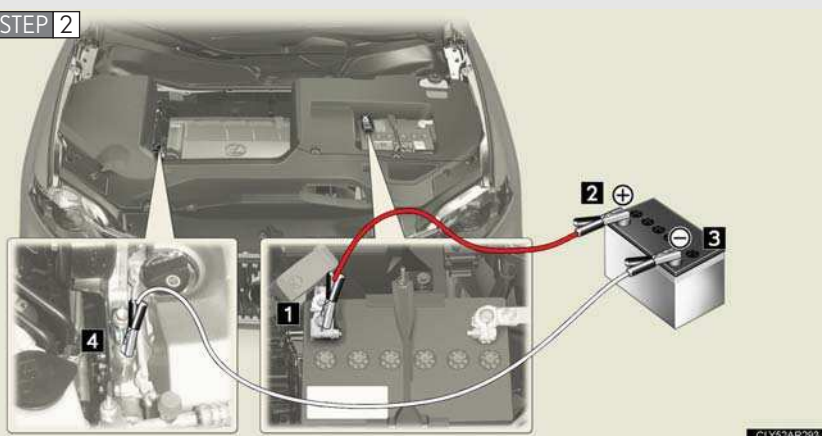

Connect the jumper cables according to the following procedure:

- 1** Connect a positive jumper cable clamp to the positive (+) battery terminal on your vehicle
- 2** Connect a positive jumper cable clamp to the positive (+) battery terminal on the second vehicle

- 3 Connect a negative cable clamp to the negative (-) battery terminal on the second vehicle
- 4 Connect the clamp at the other end of the negative cable to a solid, stationary, unpainted metallic point away from the battery and any moving parts, as shown in the illustration.
- STEP 3** Start the engine of the second vehicle. Increase the engine speed slightly and maintain that level for approximately 5 minutes to recharge the battery of your vehicle.
- STEP 4** Open and close any of the doors with the “ENGINE START STOP” switch off.
- STEP 5** Maintain the engine speed of the second vehicle and start the engine of your vehicle by turning the “ENGINE START STOP” switch to IGNITION ON mode.
- STEP 6** Once the vehicle’s engine has started, remove the jumper cables in the exact reverse order from which they were connected.

Once the engine starts, have the vehicle inspected at your Lexus dealer as soon as possible.

#### n **Starting the engine when the battery is discharged**

The engine cannot be started by push-starting.

#### n **To prevent battery discharge**

- 1 Turn off the headlights and the audio system while the engine is off.
- 1 Turn off any unnecessary electrical components when the vehicle is running at a low speed for an extended period, such as in heavy traffic.

#### n **When the battery is removed or discharged**

The power back door must be initialized. (→P. 630)

 **CAUTION**

**n Avoiding battery fires or explosions**

Observe the following precautions to prevent accidentally igniting the flammable gas that may be emitted from the battery:

- I Make sure each jumper cable is connected to the correct terminal.
- I Do not allow the “+” and “-” terminals of the jumper cables to come into contact with each other.
- I Do not smoke, use matches, cigarette lighters or allow open flame near the battery.

**n Battery precautions**

The battery contains poisonous and corrosive acidic electrolyte, while related parts contain lead and lead compounds. Observe the following precautions when handling the battery:

- I When working with the battery, always wear safety glasses and take care not to allow any battery fluids (acid) to come into contact with skin, clothing or the vehicle body.
- I Do not lean over the battery.
- I In the event that battery fluid comes into contact with the skin or eyes, immediately wash the affected area with water and seek medical attention.  
Place a wet sponge or cloth over the affected area until medical attention can be received.
- I Always wash your hands after handling the battery support, terminals, and other battery-related parts.
- I Do not allow children near the battery.

 **NOTICE**

**n When handling jumper cables**

When connecting the jumper cables, ensure that they do not become entangled in the cooling fans or belt.

## 5-2. Steps to take in an emergency If your vehicle overheats

### If your engine overheats:

**STEP 1** Stop the vehicle in a safe place and turn off the air conditioning system.

**STEP 2** Check to see if steam is coming out from under the hood.

If you see steam:

Stop the engine. Carefully lift the hood after the steam subsides and then restart the engine.

If you do not see steam:

Leave the engine running and carefully lift the hood.

**STEP 3** Remove the engine compartment cover. (→P. 464)

**STEP 4** Check to see if the cooling fan is operating.

If the fan is operating:

Wait until the temperature of the engine (shown on the instrument panel) begins to fall and then stop the engine.

If the fan is not operating:

Stop the engine immediately and call your Lexus dealer.

**STEP 5**

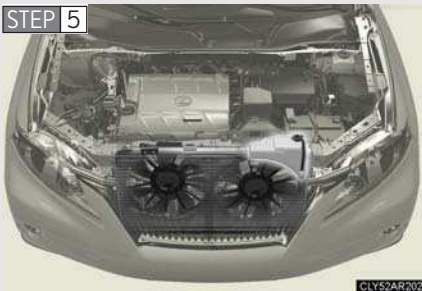

After the engine has cooled down sufficiently, check the engine coolant level and inspect the radiator core (radiator) for any leaks.



STEP 6



Add engine coolant if necessary.

Water can be used in an emergency if engine coolant is unavailable. (→P. 599)

Have the vehicle inspected at the nearest Lexus dealer as soon as possible.

### n Overheating

If you observe the following, your vehicle may be overheating:

- 1 The engine coolant temperature gauge enters the red zone or a loss of power is experienced.
- 1 Steam comes out from under the hood.

### ! CAUTION

#### n To prevent an accident or injury when inspecting under the hood of your vehicle

- 1 If steam is seen coming from under the hood, do not open the hood until the steam has subsided. The engine compartment may be very hot, causing serious injuries such as burns.
- 1 Keep hands and clothing away from the fans and drive belt while the engine is running.
- 1 Do not loosen the radiator cap while the engine and radiator are hot. Serious injury, such as burns, may result from hot coolant and steam released under pressure.

 NOTICE**n When adding engine coolant**

Wait until the engine has cooled down before adding engine coolant.

When adding coolant, do so slowly. Adding cool coolant to a hot engine too quickly can cause damage to the engine.

## 5-2. Steps to take in an emergency If the vehicle becomes stuck

Carry out the following procedures if the tires spin or the vehicle becomes stuck in mud, dirt, or snow:

**STEP 1** Stop the engine. Set the parking brake and shift the shift lever to P.

**STEP 2** Remove the mud, snow, or sand from around the stuck tire.

**STEP 3** Place wood, stones or some other material under the tires to help provide traction.

**STEP 4** Restart the engine.

**STEP 5** AWD models: Active all-wheel drive lock mode (→P. 237)

**STEP 6** Shift the shift lever to the D or R position and carefully apply the accelerator to free the vehicle.

Turn off the TRAC and VSC systems if these functions are hampering your attempts to free the vehicle. (→ P. 233)

### CAUTION

#### **n** When attempting to free a stuck vehicle

If you choose to push the vehicle back and forth to free it, make sure the surrounding area is clear to avoid striking other vehicles, objects or people. The vehicle may also lunge forward or lunge back suddenly as it becomes free. Use extreme caution.

#### **n** When shifting the shift lever

Be careful not to shift the shift lever with the accelerator pedal depressed. This may lead to unexpected rapid acceleration of the vehicle that may cause an accident and resulting in death or serious injury.

### NOTICE

#### **n** To avoid damage to the transmission and other components

**1** Avoid spinning the wheels.

**1** If the vehicle remains stuck even after these procedures are performed, the vehicle may require towing to be freed.

## 5-2. Steps to take in an emergency

### If your vehicle has to be stopped in an emergency

Only in an emergency, such as if it becomes impossible to stop the vehicle in the normal way, stop the vehicle using the following procedure:

**STEP 1** Steadily step on the brake pedal with both feet and firmly depress it.

Do not pump the brake pedal repeatedly as this will increase the effort required to slow the vehicle.

**STEP 2** Shift the shift lever to N.

► If the shift lever is shifted to N

**STEP 3** After slowing down, stop the vehicle in a safe place by the road.

**STEP 4** Stop the engine.

► If the shift lever cannot be shifted to N

**STEP 3** Keep depressing the brake pedal with both feet to reduce vehicle speed as much as possible.

**STEP 4**

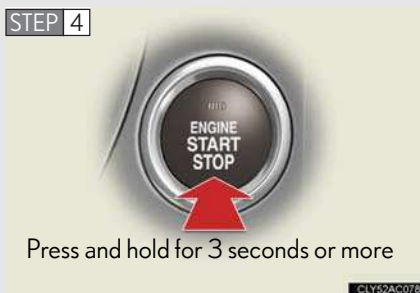

Press and hold for 3 seconds or more

CLY52AC076

Stop the engine by pressing and holding the “ENGINE START STOP” switch for 3 consecutive seconds or more.

**STEP 5** Stop the vehicle in a safe place by the road.

#### CAUTION

##### **n** If the engine has to be turned off while driving

Power assist for the brakes and steering wheel will be lost, making the brake pedal harder to depress and the steering wheel heavier to turn. Decelerate as much as possible before turning off the engine.







## 6-1. Specifications

### Maintenance data (fuel, oil level, etc.)

#### Dimensions and weights

Overall length	187.8 in. (4770 mm)	
Overall width	74.2 in. (1885 mm)	
Overall height* <sup>1</sup>	66.3 in. (1685 mm)* <sup>2</sup> 66.7 in. (1695 mm)* <sup>3</sup> 67.9 in. (1725 mm)* <sup>4</sup>	
Wheelbase	107.9 in. (2740 mm)	
Tread	Front	64.1 in. (1630 mm)
	Rear	63.8 in. (1620 mm)
Vehicle capacity weight (Occupants + luggage)	885 lb. (400 kg)	
Towing capacity (Trailer weight + cargo)	Without towing package	2000 lb. (907 kg)
	With towing package	3500 lb. (1588 kg)

\*1: Unladen vehicles

\*2: Vehicles without roof antenna and roof rails

\*3: Vehicles with roof antenna but without roof rails

\*4: Vehicles with roof rails



## Vehicle identification

### n Vehicle identification number

The vehicle identification number (VIN) is the legal identifier for your vehicle. This is the primary identification number for your Lexus. It is used in registering the ownership of your vehicle.

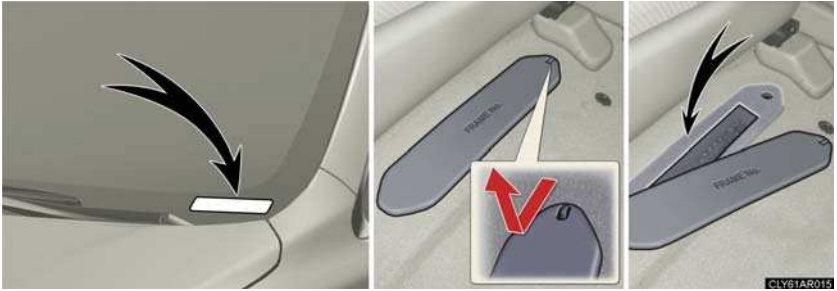

This number is stamped on the top left of the instrument. On some models, this number is also stamped under the front passenger seat.



This number is also on the Certification Label.

### n Engine number

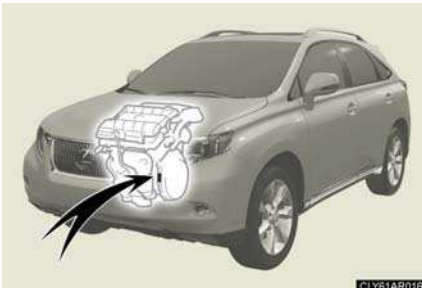

The engine number is stamped on the engine block as shown.

### Engine

Model	2GR-FE
Type	6-cylinder V type, 4-cycle, gasoline
Bore and stroke	3.70 × 3.27 in. (94.0 × 83.0 mm)
Displacement	210.9 cu.in. (3456 cm <sup>3</sup> )
Drive belt tension	Automatic adjustment

### Fuel

Fuel type	Unleaded gasoline only
Octane rating	91 (Research octane number 96) or higher
Fuel tank capacity (Reference)	19.2 gal. (72.5 L, 15.9 Imp. gal.)

## Lubrication system

Oil capacity

(Drain and refill —  
reference)

With filter

6.4 qt. (6.1 L, 5.3 Imp. qt.)

Without filter

6.0 qt. (5.7 L, 5.0 Imp. qt.)

### n Engine oil selection

“Toyota Genuine Motor Oil” is used in your Lexus vehicle. Use Lexus approved “Toyota Genuine Motor Oil” or equivalent to satisfy the following grade and viscosity.

Oil grade: ILSAC multigrade engine oil

Recommended viscosity: SAE 0W-20

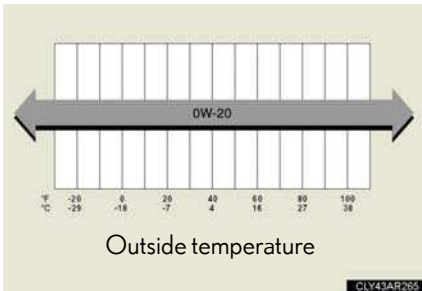

SAE 0W-20 is the best choice for good fuel economy and good starting in cold weather.

If SAE 0W-20 is not available, SAE 5W-20 oil may be used. However, it must be replaced with SAE 0W-20 at the next oil change.

The 0W portion of the oil viscosity rating indicates the characteristic of the oil which allows cold startability. Oils with a lower value before the W allow for easier starting of the engine in cold weather.

The 20 in 0W-20 indicates the oil viscosity when the oil is at its operating temperature. An oil with a higher viscosity may be better suited if the vehicle is operated at high speeds, or under extreme load conditions.

How to read oil container label:

The ILSAC (International Lubricant Standardization and Approval Committee) Certification Mark is added to some oil containers to help you select the oil you should use.



## Cooling system

Capacity	Without towing package	9.1 qt. (8.6 L, 7.6 Imp. qt.)
	With towing package	10.0 qt. (9.5 L, 8.3 Imp. qt.)
Coolant type		<p>Use either of the following.</p> <ul style="list-style-type: none"> <li>• “Toyota Super Long Life Coolant”</li> <li>• A similar high-quality ethylene glycol-based non-silicate, non-amine, non-nitrite, and non-borate coolant with long-life hybrid organic acid technology</li> </ul> <p>Do not use plain water alone.</p>

## Ignition system

Spark plug	
Make	DENSO FK20HR11
Gap	0.043 in. (1.1 mm)

### NOTICE

#### **n Iridium-tipped spark plugs**

Use only iridium-tipped spark plugs. Do not adjust spark plug gap.

## Electrical system

Battery	
Open voltage* at 68°F (20°C):	12.6 — 12.8 V Fully charged 12.2 — 12.4 V Half charged 11.8 — 12.0 V Discharged (*: Voltage checked 20 minutes after the engine and all the lights are turned off)
Charging rates	5 A max.

## Automatic transaxle

Fluid capacity *	2WD	6.8 qt. (6.5 L, 5.7 Imp. qt.)
	AWD	7.0 qt. (6.7 L, 5.9 Imp. qt.)
Fluid type	Toyota Genuine ATF WS	

\*: The fluid capacity is a reference quantity. If replacement is necessary, contact your Lexus dealer.

### NOTICE

#### **n Automatic transmission fluid type**

Using automatic transmission fluid other than “Toyota Genuine ATF WS” may cause deterioration in shift quality, locking up of your transmission accompanied by vibration, and ultimately damage the automatic transmission of your vehicle.

### Transfer (AWD models)

Oil capacity	0.8 qt. (0.8 L, 0.7 Imp. qt.)
Oil type and viscosity*	Toyota Genuine Differential gear oil LT 75W-85 GL-5 or equivalent

\*: Your Lexus vehicle is filled with “Toyota Genuine Differential Gear Oil” at the factory. Use Lexus approved “Toyota Genuine Differential Gear Oil” or an equivalent oil of matching quality that satisfies the above specifications. Please contact your Lexus dealer for further details.

### Rear differential (AWD models)

Oil capacity	0.5 qt. (0.5 L, 0.4 Imp. qt.)
Oil type and viscosity*	Toyota Genuine Differential gear oil LT 75W-85 GL-5 or equivalent

\*: Your Lexus vehicle is filled with “Toyota Genuine Differential Gear Oil” at the factory. Use Lexus approved “Toyota Genuine Differential Gear Oil” or an equivalent oil of matching quality that satisfies the above specifications. Please contact your Lexus dealer for further details.

### Brakes

Pedal clearance* <sup>1</sup>	3.3 in. (84 mm) Min.
Pedal free play	0.04 — 0.24 in. (1 — 6 mm)
Brake pad wear limit	0.04 in. (1.0 mm)
Parking brake lining wear limit	0.04 in. (1.0 mm)
Parking brake pedal travel* <sup>2</sup>	5 — 8 clicks
Fluid type	SAE J1703 or FMVSS No.116 DOT 3

\*<sup>1</sup>: Minimum pedal clearance when depressed with a force of 112 lbf (500 N, 51 kgf) while the engine is running

\*<sup>2</sup>: Parking brake pedal travel when depressed with a force of 67 lbf (300 N, 30 kgf)

## Steering

Free play

Less than 1.2 in. (30 mm)

## Tires and wheels

### ► Type A

Tire size	P235/60R18 102V, T165/90D18 107M (spare)
Tire inflation pressure (recommended cold tire inflation pressure)	Driving under normal conditions Front: 32 psi (220 kPa, 2.2 kgf/cm <sup>2</sup> or bar) Rear: 32 psi (220 kPa, 2.2 kgf/cm <sup>2</sup> or bar) Spare: 60 psi (420 kPa, 4.2 kgf/cm <sup>2</sup> or bar)
Wheel size	18 × 7 1/2J, 18 × 4T (spare)
Wheel nut torque	76 ft•lbf (103 N•m, 10.5 kgf•m)

### ► Type B

Tire size	P235/60R18 102V
Tire inflation pressure (recommended cold tire inflation pressure)	Driving under normal conditions Front: 32 psi (220 kPa, 2.2 kgf/cm <sup>2</sup> or bar) Rear: 32 psi (220 kPa, 2.2 kgf/cm <sup>2</sup> or bar) Spare: 32 psi (220 kPa, 2.2 kgf/cm <sup>2</sup> or bar)
Wheel size	18 × 7 1/2J
Wheel nut torque	76 ft•lbf (103 N•m, 10.5 kgf•m)



## ► Type C

Tire size	P235/55R19 101V, T165/90D18 107M (spare)
Tire inflation pressure (recommended cold tire inflation pressure)	<p>Driving under normal conditions</p> <p>Front: 32 psi (220 kPa, 2.2 kgf/cm<sup>2</sup> or bar)*</p> <p>Rear: 32 psi (220 kPa, 2.2 kgf/cm<sup>2</sup> or bar)*</p> <p>Spare: 60 psi (420 kPa, 4.2 kgf/cm<sup>2</sup> or bar)</p> <p>*: When driving at high speeds above 100 mph (160 km/h), in countries where such speeds are permitted by law, add 1 psi (10 kPa, 0.1 kgf/cm<sup>2</sup> or bar) to the front tires, 3 psi (20 kPa, 0.2 kgf/cm<sup>2</sup> or bar) to the rear tires. Never exceed the maximum cold tire inflation pressure indicated on the tire sidewall.</p>
Wheel size	19 × 7 1/2J, 18 × 4T (spare)
Wheel nut torque	76 ft•lbf (103 N•m, 10.5 kgf•m)

► Type D

Tire size	P235/55R19 101V
Tire inflation pressure (recommended cold tire inflation pressure)	<p>Driving under normal conditions</p> <p>Front: 32 psi (220 kPa, 2.2 kgf/cm<sup>2</sup> or bar)</p> <p>Rear: 32 psi (220 kPa, 2.2 kgf/cm<sup>2</sup> or bar)</p> <p>Spare: 32 psi (220 kPa, 2.2 kgf/cm<sup>2</sup> or bar)</p> <p>When driving at high speeds above 100 mph (160 km/h), in countries where such speeds are permitted by law, add 1 psi (10 kPa, 0.1 kgf/cm<sup>2</sup> or bar) to the front tires and rear tires. Never exceed the maximum cold tire inflation pressure indicated on the tire sidewall.</p>
Wheel size	19 × 7 1/2J
Wheel nut torque	76 ft•lbf (103 N•m, 10.5 kgf•m)

## Light bulbs

	Light Bulbs	Bulb No.	W	Type
Exterior	Discharge headlights Low/High beam	D4S	35	B
	Daytime running lights	9005	60	A
	Halogen headlights High beam and daytime running lights	9005	60	A
	Low beam	H11	55	E
	Front side marker lights	W5W	5	C
	Front turn signal lights	WY21W	21	D
	Parking lights	W5W	5	C
	Front fog lights	H11	55	E
	Rear side marker lights	W5W	5	C
	Rear turn signal lights	WY21W	21	D
	Back-up lights	921	16	C
	Tail lights	W5W	5	C
	Outer foot lights	—	5	C
	Interior	Vanity lights	—	8
Front interior lights		—	5	C
Rear interior light		—	8	C
Luggage compartment lights		—	5	C
Door courtesy lights		—	5	C
Footwell lights		—	3.8	C

- A: HB3 halogen bulbs  
 B: D4S discharge bulbs  
 C: Wedge base bulbs (clear)  
 D: Wedge base bulbs (amber)  
 E: H11 halogen bulbs

## 6-1. Specifications

### Fuel information

Your vehicle must use only unleaded gasoline.

Premium unleaded gasoline with an octane rating of 91 (Research Octane Number 96) or higher required for optimum engine performance. If 91 octane cannot be obtained, you may use unleaded gasoline with an octane rating as low as 87 (Research Octane Number 91). Use of unleaded gasoline with an octane rating lower than 91 may result in engine knocking. Persistent knocking can lead to engine damage and should be corrected by refueling with higher octane unleaded gasoline.

At minimum, the gasoline you use should meet the specifications of ASTM D4814 in the U.S.A. and CGSB3.5-M93 in Canada.

---

#### n Fuel tank opening for unleaded gasoline

To help prevent incorrect fueling, your Lexus has a fuel tank opening that only accommodates the special nozzle on unleaded fuel pumps.

#### n If your engine knocks

1 Consult your Lexus dealer.

1 You may occasionally notice light knocking for a short time while accelerating or driving uphill. This is normal and there is no need for concern.

#### n Gasoline quality

In very few cases, driveability problems may be caused by the brand of gasoline you are using. If driveability problems persist, try changing the brand of gasoline. If this does not correct the problem, consult your Lexus dealer.

### n Gasoline quality standards

- l Automotive manufacturers in the US, Europe and Japan have developed a specification for fuel quality called World-Wide Fuel Charter (WWFC) that is expected to be applied worldwide.
- l The WWFC consists of four categories that are based on required emission levels. In the US, category 4 has been adopted.
- l The WWFC improves air quality by lowering emissions in vehicle fleets, and customer satisfaction through better performance.

### n Lexus recommends the use of gasoline containing detergent additives

- l Lexus recommends the use of gasoline that contains detergent additives to avoid build-up of engine deposits.
- l All gasoline sold in the US contains detergent additives to clean and/or keep clean intake systems.

### n Lexus recommends the use of cleaner burning gasoline

Cleaner burning gasoline, including reformulated gasoline that contains oxygenates such as ethanol or MTBE (Methyl Tertiary Butyl Ether) is available in many areas.

Lexus recommends the use of cleaner burning gasoline and appropriately blended reformulated gasoline. These types of gasoline provide excellent vehicle performance, reduce vehicle emissions and improve air quality.

### n Lexus does not recommend blended gasoline

- l Lexus allows the use of oxygenate blended gasoline where the oxygenate content is up to 10% ethanol or 15% MTBE.
- l If you use gasohol in your Lexus, be sure that it has an octane rating no lower than 87.
- l Lexus DOES NOT recommend the use of gasoline containing methanol.

### n Lexus does not recommend gasoline containing MMT

Some gasoline contains octane enhancing additive called MMT (Methylcyclopentadienyl Manganese Tricarbonyl).

Lexus DOES NOT recommend the use of gasoline that contains MMT. If fuel containing MMT is used, your emission control system may be adversely affected.

The malfunction indicator lamp on the instrument cluster may come on. If this happens, contact your Lexus dealer for service.

 NOTICE

**n Notice on fuel quality**

- I** Do not use improper fuels. If improper fuels are used the engine will be damaged.
- I** Do not use leaded gasoline.  
Leaded gasoline can cause damage to your vehicle's three-way catalytic converters causing the emission control system to malfunction.
- I** Do not use gasohol other than that stated here.  
Other gasohol may cause fuel system damage or vehicle performance problems.
- I** Using unleaded gasoline with an octane number or rating lower than that stated here will cause persistent heavy knocking.  
At worst, this will lead to engine damage.

**n Fuel-related poor driveability**

If after using a different type of fuel, poor driveability is encountered (poor hot starting, vaporization, engine knocking, etc.), discontinue the use of that type of fuel.

**n When refueling with gasohol**

Take care not to spill gasohol. It can damage your vehicle's paint.

# 6-1. Specifications

## Tire information

### Typical tire symbols

#### ▶ Standard tire



#### ▶ Compact spare tire

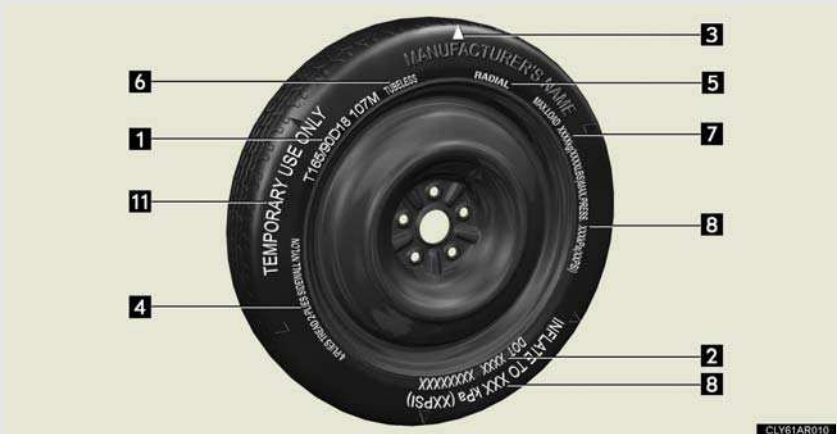

- 1** Tire size (→P. 612)
- 2** DOT and Tire Identification Number (TIN) (→P. 611)
- 3** Location of treadwear indicators (→P. 478)

### 4 Tire ply composition and materials

Ply is layers of rubber-coated parallel cords. Cords are the strands which form the plies in a tire.

### 5 Radial tires or bias-ply tires

A radial tire has "RADIAL" on the sidewall. A tire not marked "RADIAL" is a bias-ply tire.

### 6 TUBELESS or TUBE TYPE

A tubeless tire does not have a tube and air is directly filled in the tire. A tube type tire has a tube inside the tire and the tube maintains the air pressure.

### 7 Load limit at maximum cold tire inflation pressure (→P. 482)

### 8 Maximum cold tire inflation pressure (→P. 602)

This means the pressure to which a tire may be inflated.

### 9 Uniform tire quality grading

For details, see "Uniform tire quality grading" that follows.

### 10 Summer tire or all season tire (→P. 482)

An all season tire has "M+S" on the sidewall. A tire not marked "M+S" is a summer tire.

### 11 "TEMPORARY USE ONLY" (→P. 573)

A compact spare tire is identified by the phrase "TEMPORARY USE ONLY" molded on its sidewall. This tire is designed for temporary emergency use only.



## Typical DOT and tire identification number (TIN)

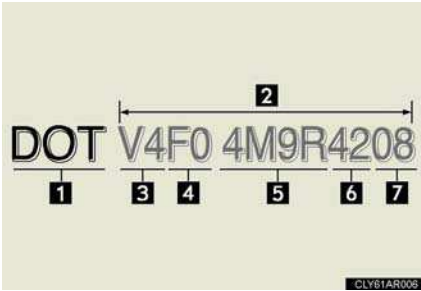

- 1 DOT symbol\*
- 2 Tire Identification Number (TIN)
- 3 Tire manufacturer's identification mark
- 4 Tire size code
- 5 Manufacturer's optional tire type code (3 or 4 letters)
- 6 Manufacturing week
- 7 Manufacturing year

\*:The DOT symbol certifies that the tire conforms to applicable Federal Motor Vehicle Safety Standards.

## Tire size

### n Typical tire size information

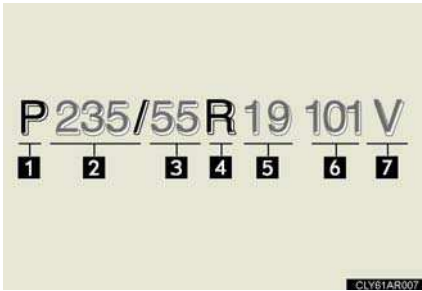

The illustration indicates typical tire size.

- 1** Tire use  
(P = Passenger car,  
T = Temporary use)
- 2** Section width (millimeters)
- 3** Aspect ratio  
(tire height to section width)
- 4** Tire construction code  
(R = Radial, D = Diagonal)
- 5** Wheel diameter (inches)
- 6** Load index (2 digits or 3 digits)
- 7** Speed symbol  
(alphabet with one letter)

### n Tire dimensions



- 1** Section width
- 2** Tire height
- 3** Wheel diameter

## Tire section names

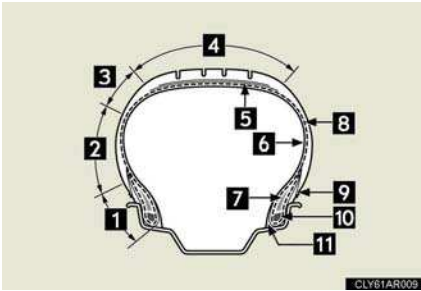

- 1 Bead
- 2 Sidewall
- 3 Shoulder
- 4 Tread
- 5 Belt
- 6 Inner liner
- 7 Reinforcing rubber
- 8 Carcass
- 9 Rim lines
- 10 Bead wires
- 11 Chafer

## Uniform Tire Quality Grading

This information has been prepared in accordance with regulations issued by the National Highway Traffic Safety Administration of the U.S. Department of Transportation.

It provides the purchasers and/or prospective purchasers of Lexus vehicles with information on uniform tire quality grading.

Your Lexus dealer will help answer any questions you may have as you read this information.

### n DOT quality grades

All passenger vehicle tires must conform to Federal Safety Requirements in addition to these grades. Quality grades can be found where applicable on the tire sidewall between tread shoulder and maximum section width.

For example: Treadwear 200 Traction AA Temperature A

### **n Treadwear**

The treadwear grade is a comparative rating based on the wear rate of the tire when tested under controlled conditions on a specified government test course.

For example, a tire graded 150 would wear one and a half (1 - 1/2) times as well on the government course as a tire graded 100.

The relative performance of tires depends upon the actual conditions of their use, however, and may depart significantly from the norm due to variations in driving habits, service practices and differences in road characteristics and climate.

### **n Traction AA, A, B, C**

The traction grades, from highest to lowest, are AA, A, B and C, and they represent the tire's ability to stop on wet pavement as measured under controlled conditions on specified government test surfaces of asphalt and concrete.

A tire marked C may have poor traction performance.

Warning: The traction grade assigned to this tire is based on braking (straight ahead) traction tests and does not include cornering (turning) traction.

### **n Temperature A, B, C**

The temperature grades are A (the highest), B, and C, representing the tire's resistance to the generation of heat and its ability to dissipate heat when tested under controlled conditions on a specified indoor laboratory test wheel.

Sustained high temperature can cause the material of the tire to degenerate and reduce tire life, and excessive temperature can lead to sudden tire failure.

The grade C corresponds to a level of performance which all passenger car tires must meet under the Federal Motor Vehicle Safety Standard No. 109.

Grades B and A represent higher levels of performance on the laboratory test wheel than the minimum required by law.

Warning: The temperature grades for this tire are established for a tire that is properly inflated and not overloaded.

Excessive speed, underinflation, or excessive loading, either separately or in combination, can cause heat buildup and possible tire failure.

### Glossary of tire terminology

Tire related term	Meaning
Cold tire inflation pressure	Tire pressure when the vehicle has been parked for three hours or more, or has not been driven more than 1 mile or 1.5 km under that condition
Maximum inflation pressure	The maximum cold inflated pressure to which a tire may be inflated, shown on the sidewall of the tire
Recommended inflation pressure	Cold tire inflation pressure recommended by a manufacturer
Accessory weight	The combined weight (in excess of those standard items which may be replaced) of automatic transmission, power steering, power brakes, power windows, power seats, radio and heater, to the extent that these items are available as factory-installed equipment (whether installed or not)
Curb weight	The weight of a motor vehicle with standard equipment, including the maximum capacity of fuel, oil and coolant, and if so equipped, air conditioning and additional weight optional engine
Maximum loaded vehicle weight	The sum of: (a) Curb weight (b) Accessory weight (c) Vehicle capacity weight (d) Production options weight
Normal occupant weight	150 lb. (68 kg) times the number of occupants specified in the second column of Table 1* that follows

## 6-1. Specifications

Tire related term	Meaning
Occupant distribution	Distribution of occupants in a vehicle as specified in the third column of Table 1* below
Production options weight	The combined weight of installed regular production options weighing over 5 lb. (2.3 kg) in excess of the standard items which they replace, not previously considered in curb weight or accessory weight, including heavy duty brakes, ride levelers, roof rack, heavy duty battery, and special trim
Rim	A metal support for a tire or a tire and tube assembly upon which the tire beads are seated
Rim diameter (Wheel diameter)	Nominal diameter of the bead seat
Rim size designation	Rim diameter and width
Rim type designation	The industry manufacturer's designation for a rim by style or code
Rim width	Nominal distance between rim flanges
Vehicle capacity weight (Total load capacity)	The rated cargo and luggage load plus 150 lb. (68 kg) times the vehicle's designated seating capacity
Vehicle maximum load on the tire	The load on an individual tire that is determined by distributing to each axle its share of the maximum loaded vehicle weight, and dividing by two
Vehicle normal load on the tire	The load on an individual tire that is determined by distributing to each axle its share of curb weight, accessory weight, and normal occupant weight (distributed in accordance with Table 1* below), and dividing by two
Weather side	The surface area of the rim not covered by the inflated tire

Tire related term	Meaning
Bead	The part of the tire that is made of steel wires, wrapped or reinforced by ply cords and that is shaped to fit the rim
Bead separation	A breakdown of the bond between components in the bead
Bias ply tire	A pneumatic tire in which the ply cords that extend to the beads are laid at alternate angles substantially less than 90 degrees to the centerline of the tread
Carcass	The tire structure, except tread and sidewall rubber which, when inflated, bears the load
Chunking	The breaking away of pieces of the tread or sidewall
Cord	The strands forming the plies in the tire
Cord separation	The parting of cords from adjacent rubber compounds
Cracking	Any parting within the tread, sidewall, or innerliner of the tire extending to cord material
CT	A pneumatic tire with an inverted flange tire and rim system in which the rim is designed with rim flanges pointed radially inward and the tire is designed to fit on the underside of the rim in a manner that encloses the rim flanges inside the air cavity of the tire
Extra load tire	A tire designed to operate at higher loads and at higher inflation pressures than the corresponding standard tire
Groove	The space between two adjacent tread ribs
Innerliner	The layer(s) forming the inside surface of a tubeless tire that contains the inflating medium within the tire
Innerliner separation	The parting of the innerliner from cord material in the carcass

Tire related term	Meaning
Intended outboard sidewall	(a) The sidewall that contains a whitewall, bears white lettering, or bears manufacturer, brand, and/or model name molding that is higher or deeper than the same molding on the other sidewall of the tire, or (b) The outward facing sidewall of an asymmetrical tire that has a particular side that must always face outward when mounted on a vehicle
Light truck (LT) tire	A tire designated by its manufacturer as primarily intended for use on lightweight trucks or multipurpose passenger vehicles
Load rating	The maximum load that a tire is rated to carry for a given inflation pressure
Maximum load rating	The load rating for a tire at the maximum permissible inflation pressure for that tire
Maximum permissible inflation pressure	The maximum cold inflation pressure to which a tire may be inflated
Measuring rim	The rim on which a tire is fitted for physical dimension requirements
Open splice	Any parting at any junction of tread, sidewall, or innerliner that extends to cord material
Outer diameter	The overall diameter of an inflated new tire
Overall width	The linear distance between the exteriors of the sidewalls of an inflated tire, including elevations due to labeling, decorations, or protective bands or ribs
Passenger car tire	A tire intended for use on passenger cars, multipurpose passenger vehicles, and trucks, that have a gross vehicle weight rating (GVWR) of 10,000 lb. or less.
Ply	A layer of rubber-coated parallel cords



Tire related term	Meaning
Ply separation	A parting of rubber compound between adjacent plies
Pneumatic tire	A mechanical device made of rubber, chemicals, fabric and steel or other materials, that, when mounted on an automotive wheel, provides the traction and contains the gas or fluid that sustains the load
Radial ply tire	A pneumatic tire in which the ply cords that extend to the beads are laid at substantially 90 degrees to the centerline of the tread
Reinforced tire	A tire designed to operate at higher loads and at higher inflation pressures than the corresponding standard tire
Section width	The linear distance between the exteriors of the sidewalls of an inflated tire, excluding elevations due to labeling, decoration, or protective bands
Sidewall	That portion of a tire between the tread and bead
Sidewall separation	The parting of the rubber compound from the cord material in the sidewall
Snow tire	A tire that attains a traction index equal to or greater than 110, compared to the ASTM E-1136 Standard Reference Test Tire, when using the snow traction test as described in ASTM F-1805-00, Standard Test Method for Single Wheel Driving Traction in a Straight Line on Snow-and Ice-Covered Surfaces, and which is marked with an Alpine Symbol (  ) on at least one sidewall
Test rim	The rim on which a tire is fitted for testing, and may be any rim listed as appropriate for use with that tire

Tire related term	Meaning
Tread	That portion of a tire that comes into contact with the road
Tread rib	A tread section running circumferentially around a tire
Tread separation	Pulling away of the tread from the tire carcass
Treadwear indicators (TWI)	The projections within the principal grooves designed to give a visual indication of the degrees of wear of the tread
Wheel-holding fixture	The fixture used to hold the wheel and tire assembly securely during testing

\*: Table 1 — Occupant loading and distribution for vehicle normal load for various designated seating capacities

Designated seating capacity, Number of occupants	Vehicle normal load, Number of occupants	Occupant distribution in a normally loaded vehicle
2 through 4	2	2 in front
5 through 10	3	2 in front, 1 in second seat
11 through 15	5	2 in front, 1 in second seat, 1 in third seat, 1 in fourth seat
16 through 20	7	2 in front, 2 in second seat, 2 in third seat, 1 in fourth seat



# Customizable features

Your vehicle includes a variety of electronic features that can be personalized to suit your preferences. Programming of these preferences can be performed by your Lexus dealer.

It is also possible to customize certain vehicle features yourself using the multi-information switches and the navigation screen.

Some function settings are changed simultaneously with other functions being customized. Contact your Lexus dealer for further details.

### Customizing vehicle features

It is possible to customize certain vehicle features using the multi-information switches.\*

When customizing vehicle features, ensure that the vehicle is parked in a safe place with the shift lever in P and the parking brake set.

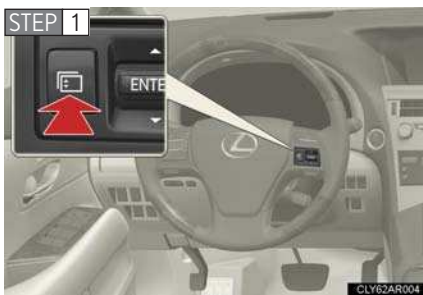

Press and hold the menu switch of the multi-information switches to display customization mode.



1 Press the "ENTER" switch upwards or downwards to select the item to be customized.

2 Press the "ENTER" switch to confirm.



- 1 Press the “ENTER” switch upwards or downwards to select the desired setting for the item being customized.
- 2 Press the “ENTER” switch to confirm.

When customization is completed, press the menu switch to clear the customization screen.

\*:For instructions on customizing vehicle features using the navigation screen, refer to the “Navigation System Owner’s Manual”.

## Customizable Features

- 1 Vehicles with a navigation system: Settings that can be changed using the screen of the navigation system
- 2 Vehicles with a navigation system: Settings that can be changed using the multi-information switches
- 3 Vehicles without a navigation system: Settings that can be changed using the multi-information switches
- 4 Settings that can be changed by your Lexus dealer

Definition of symbols: ○ = Available, – = Not available

Item	Function	Default setting	Customized setting	1	2	3	4
Door lock (→P. 47, 581)	Unlocking using a key	Driver's door unlocked in one step, all doors unlocked in two steps	All doors unlocked in one step	○	–	–	○
	Speed-detecting automatic door lock function	Off	On	○	–	○	○
	Shifting gears to position other than P locks all doors	On	Off	○	–	○	○

Item	Function	Default setting	Customized setting	1	2	3	4
Door lock (→P. 47, 581)	Shifting gears to P unlocks all doors	On	Off	○	–	○	○
	Opening driver's door unlocks all doors	Off	On	○	–	○	○
Smart access system with push-button start and wireless remote control (→P. 31, 43)	Operation signal (buzzer)	7	Off	○	–	○	○
			1 to 6				
	Operation signal (emergency flashers)	On	Off	○	–	○	○
Time elapsed before the automatic door lock function is activated if a door is not opened after being unlocked	60 seconds	Off	○	–	○	○	
		30 seconds					
			120 seconds				
Smart access system with push-button start (→P. 31)	Smart door unlocking	Driver's door	All the doors	○	–	○	○
	Smart access system with push-button start	On	Off	○	–	○	○

Item	Function	Default setting	Customized setting	1	2	3	4
Power back door (→P. 51)	Power back door opening operation using the back door opener button	Off	On	-	-	-	○
Wireless remote control (→P. 43)	Unlocking operation	Driver's door unlocked in one step, all doors unlocked in two steps	All doors unlocked in one step	○	-	○	○
Automatic light control system (→P. 184)	Time elapsed before the headlights turn off	30 seconds	Off	○	-	○	○
			60 seconds				
			90 seconds				
	Light sensor sensitivity	Standard	-2 to 2	○	-	○	○
	Daytime running light system	On	Off	○	-	○	○
Automatic high beam system	On	Off	-	-	-	○	



Item	Function	Default setting	Customized setting	1	2	3	4
Illumination (→P. 396)	Time elapsed before the interior lights turn off	15 seconds	Off				
			7.5 seconds	○	–	○	○
			30 seconds				
	Time elapsed before the exterior lights turn off	15 seconds	Off				
			7.5 seconds	○	–	○	○
			30 seconds				
	Sensitivity of the ambient light sensor used for dimming the meter lights etc.	Standard	-2 to 2	○	–	–	○
	Sensitivity of the ambient light sensor used for brightening the meter lights etc.	Standard	-2 to 2	○	–	–	○
	Footwell lights	On	Off	–	–	–	○
	Outer foot lights	On	Off	–	–	–	○

Item	Function	Default setting	Customized setting	1	2	3	4
Automatic air conditioning system (→P. 274)	Switching between outside air and recirculated air mode linked to "AUTO" switch operation	Auto	Manual	○	–	–	○
	A/C auto switch operation	Auto	Manual	○	–	–	○
	Exhaust gas sensor sensitivity	Standard	-3 to 3	○	–	–	○
Front seats (→P. 61)	Driver's seat movement when exiting the vehicle (on some models)	Full	Off				
			Partial	○	–	○	○
Eco Driving Indicator Light (→P. 177)	Eco Driving Indicator Light	On	Off	–	○	○	○
Power windows (→P. 90)	Mechanical key linked operation	On	Off	–	–	–	○
	Wireless remote control linked operation	On	Off	–	–	–	○

Item	Function	Default setting	Customized setting	1	2	3	4
Moon roof (→P. 93)	Mechanical key linked operation	On	Off	-	-	-	○
	Wireless remote control linked operation	On	Off	-	-	-	○
Intuitive parking assist (→P. 220)	Buzzer volume	3	1 to 5	○	-	-	○
	Detection distance of the rear center sensor	Far	Near	○	-	-	○
	Display setting (when intuitive parking assist is operating)	All sensors displayed	No sensor displayed	○	-	-	○

## Multi-information display (→P.173)

Settings that can be changed using the multi-information switches

Available units	miles (MPG), km (km/l), km (l/100 km)
Available languages	English, French and Spanish

**n In the following situations, customize mode will automatically be turned off.**

- 1 A warning message appears after the customize mode screen is displayed.
- 1 The “ENGINE START STOP” switch is turned off.
- 1 The vehicle begins to move while the customize mode screen is displayed.

### CAUTION

**n Cautions during customization**

As the engine needs to be running during customization, ensure that the vehicle is parked in a place with adequate ventilation. In a closed area such as a garage, exhaust gases including harmful carbon monoxide (CO) may collect and enter the vehicle. This may lead to death or a serious health hazard.

### NOTICE

**n During customization**

To prevent battery discharge, ensure that the engine is running while customizing features.

## 6-3. Initialization

### Items to initialize

The following items must be initialized for normal system operation in cases such as after the battery is reconnected, or maintenance is performed on the vehicle.

Item	When to initialize	Reference
Power back door (if equipped)	<ul style="list-style-type: none"><li>• After reconnecting or changing the battery</li><li>• After changing a fuse</li></ul>	P. 50
Engine oil maintenance data (U.S.A. only)	After changing engine oil	P. 468
Tire pressure warning system	<ul style="list-style-type: none"><li>• When changing tire pressure (such as when changing traveling speed, load weight, etc.)</li><li>• When changing the tire size</li></ul>	P. 479

## Reporting safety defects for U.S. owners

If you believe that your vehicle has a defect which could cause a crash or could cause injury or death, you should immediately inform the National Highway Traffic Safety Administration (NHTSA) in addition to notifying the Lexus Division of Toyota Motor Sales, U.S.A., Inc. (Toll-free: 1-800-25-LEXUS).

If NHTSA receives similar complaints, it may open an investigation, and if it finds that a safety defect exists in a group of vehicles, it may order a recall and remedy campaign. However, NHTSA cannot become involved in individual problems between you, your dealer, or Lexus Division of Toyota Motor Sales, U.S.A., Inc.

To contact NHTSA, you may call the Vehicle Safety Hotline toll-free at 1-888-327-4236 (TTY: 1-800-424-9153); go to <http://www.safercar.gov>; or write to: Administrator, NHTSA, 1200 New Jersey Ave, S.E., Washington, DC 20590. You can also obtain other information about motor vehicle safety from <http://www.safercar.gov>.

## Seat belt instructions for Canadian owners (in French)

The following is a French explanation of seat belt instructions extracted from the seat belt section in this manual.

See the seat belt section for more detailed seat belt instructions in English.

### Utilisation correcte des ceintures de sécurité



- Déroulez la sangle diagonale de telle sorte qu'elle passe bien sur l'épaule, sans pour autant être en contact avec votre cou ou glisser de votre épaule.
- Placez la sangle abdominale le plus bas possible sur les hanches.
- Réglez la position du dossier de siège. Asseyez-vous le dos le plus droit possible et caliez-vous bien dans le siège.
- Ne vrillez pas la ceinture de sécurité.

## Guide confort de ceinture de sécurité (sièges arrière extérieurs)

Si la sangle diagonale gêne la personne au niveau du cou, utilisez le guide confort de la ceinture de sécurité.

ÉTAPE 1



Sortez le guide confort de sa poche.

ÉTAPE 2

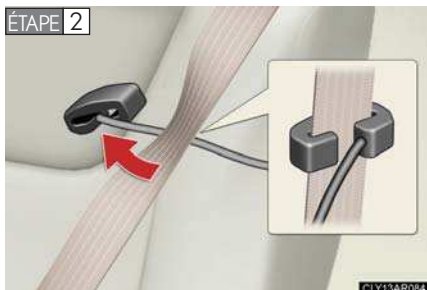

Engagez la ceinture dans le guide.

Le cordon élastique doit passer sous la ceinture de sécurité.

ÉTAPE 3



Bouclez la ceinture de sécurité, puis positionnez-la et lâchez-la.



## Entretien et soin

### ■ Ceintures de sécurité

Nettoyez avec un chiffon ou une éponge humectée d'eau savonneuse tiède. Profitez de l'occasion pour vérifier régulièrement que les ceintures ne sont pas effilochées, entaillées, ou ne paraissent pas exagérément usées.

### ATTENTION

#### ■ Détérioration et usure des ceintures de sécurité

Inspectez les ceintures de sécurité périodiquement. Contrôlez qu'elles ne sont pas entaillées, effilochées, et que leurs ancrages ne sont pas desserrés. N'utilisez pas une ceinture de sécurité défectueuse avant qu'elle ne soit remplacée. Une ceinture de sécurité défectueuse n'apporte aucune garantie de protection de l'occupant en cas d'accident.

## SRS airbag instructions for Canadian owners (in French)

The following is a French explanation of SRS airbag instructions extracted from the SRS airbag section in this manual.

See the SRS airbag section for more detailed SRS airbag instructions in English.

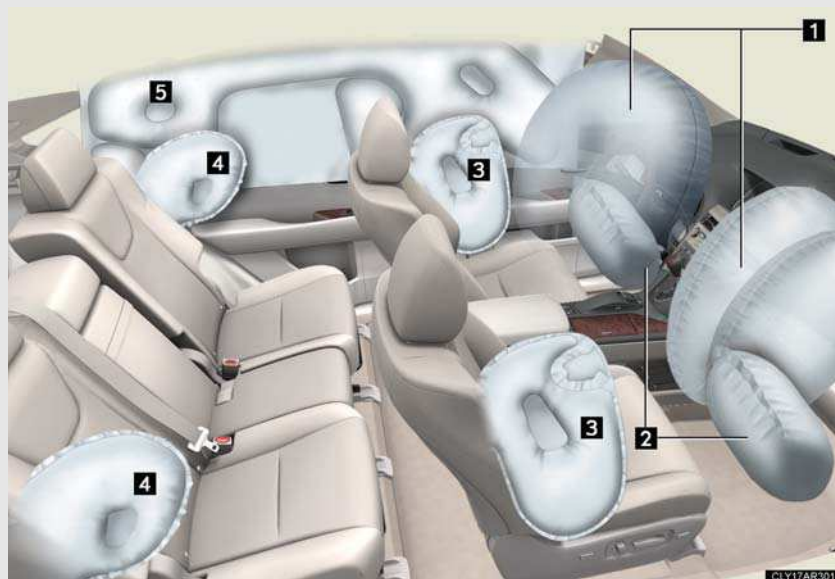

► Sacs de sécurité gonflables SRS frontaux

**1** Sac de sécurité gonflable conducteur/sac de sécurité gonflable passager avant SRS

Participent à la protection de la tête et du thorax du conducteur et du passager avant contre les chocs avec les éléments de l'habitacle

**2** Sacs de sécurité gonflables SRS de genoux

Participent à la protection du conducteur et du passager avant

- ▶ Sacs de sécurité gonflables SRS latéraux et rideau
- 3 Sacs de sécurité gonflables SRS latéraux avant  
Participent à la protection du haut du corps des occupants aux places avant
- 4 Sacs de sécurité gonflables SRS latéraux arrière  
Participent à la protection du thorax des occupants assis aux places arrière extérieures
- 5 Sacs de sécurité gonflables SRS rideau  
Participent principalement à la protection de la tête des occupants assis aux places extérieures

## Composition du système de sacs de sécurité gonflables SRS

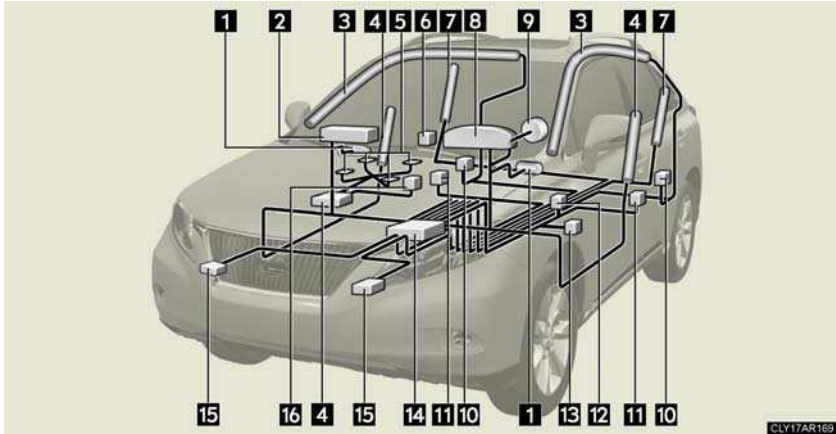

CLY17AR169

- |  |   |
|--|---|
| <b>1</b> Sacs de sécurité gonflables de genoux                                   | <b>10</b> Capteurs de sacs de sécurité gonflables rideau              |
| <b>2</b> Sac de sécurité gonflable passager avant                                | <b>11</b> Capteurs de sacs de sécurité gonflables latéraux et rideau  |
| <b>3</b> Sacs de sécurité gonflables rideau                                      | <b>12</b> Contacteur de boucle de ceinture de sécurité conducteur     |
| <b>4</b> Sacs de sécurité gonflables latéraux avant                              | <b>13</b> Capteur de position du siège conducteur                     |
| <b>5</b> Système de détection du passager (calculateur électronique et capteurs) | <b>14</b> Boîtier électronique de sacs de sécurité gonflables         |
| <b>6</b> Témoins indicateurs "AIR BAG ON" et "AIR BAG OFF"                       | <b>15</b> Capteurs de sacs de sécurité gonflables frontaux            |
| <b>7</b> Sacs de sécurité gonflables latéraux arrière                            | <b>16</b> Contacteur de boucle de ceinture de sécurité passager avant |
| <b>8</b> Témoin d'alerte SRS   |   |
| <b>9</b> Sac de sécurité gonflable conducteur                                    |   |

Votre véhicule est équipé de SACS DE SÉCURITÉ GONFLABLES INTELLIGENTS (ADVANCED AIRBAGS) conçus selon les normes de sécurité américaines applicables aux véhicules à moteur (FMVSS208). Le système de sacs de sécurité gonflables régule la puissance de déploiement des sacs de sécurité gonflables conducteur et passager avant. Le système de sac de sécurité gonflable conducteur comprend le capteur de position du siège conducteur, etc. Le système de sac de sécurité gonflable passager avant comprend le capteur de classification des occupants du siège passager avant, etc.

Les principaux éléments du système de sacs de sécurité gonflables SRS sont illustrés ci-dessus. Le système des sacs de sécurité gonflables SRS est commandé par un boîtier électronique. Ce boîtier intègre un capteur de sécurité et un capteur de sac de sécurité gonflable.

Lorsque la violence du choc frontal ou latéral l'exige, le système de sacs de sécurité gonflables SRS déclenche les dispositifs pyrotechniques de gonflage (générateurs de gaz). Le déploiement rapide des sacs de sécurité gonflables est obtenu au moyen d'une réaction chimique dans les dispositifs pyrotechniques, qui produit un gaz inoffensif permettant d'amortir le mouvement des occupants.

## ATTENTION

### ■ Précautions à observer avec les sacs de sécurité gonflables SRS

Respectez les précautions suivantes concernant les sacs de sécurité gonflables SRS.

À défaut, des blessures graves, voire mortelles, pourraient s'ensuivre.

- Le conducteur et tous les passagers à bord du véhicule doivent porter leur ceinture de sécurité correctement.

Les sacs de sécurité gonflables SRS sont des dispositifs de protection complémentaires aux ceintures de sécurité.

- Le sac de sécurité gonflable SRS conducteur se déploie avec une violence considérable, qui peut être très dangereuse voire mortelle si le conducteur se trouve très près du sac de sécurité gonflable. L'autorité fédérale chargée de la sécurité routière aux États-Unis, la NHTSA (National Highway Traffic Safety Administration) conseille:

La zone à risque du sac de sécurité gonflable conducteur se situant dans les premiers 2 à 3 in. (50 à 75 mm) de déploiement, vous disposez d'une confortable marge de sécurité en vous plaçant à 10 in. (250 mm) de votre sac de sécurité gonflable conducteur. Cette distance est mesurée entre le centre du volant de direction et votre sternum. Si vous êtes actuellement assis à moins de 10 in. (250 mm), vous pouvez changer votre position de conduite de différentes façons:

- Reculez votre siège le plus possible, tout en continuant à pouvoir atteindre confortablement les pédales.
- Inclinez légèrement le dossier du siège.

Bien que les véhicules puissent être différents les uns des autres, la plupart des conducteurs peuvent s'asseoir à une distance de 10 in. (250 mm), même avec le siège conducteur complètement avancé, simplement en inclinant un peu le dossier de siège. Si vous avez des difficultés à voir la route après avoir incliné votre siège, utilisez un coussin ferme et antidérapant pour vous rehausser ou, si votre véhicule est équipé du réglage en hauteur du siège, remontez-le.

- Si votre volant de direction est réglable, inclinez-le vers le bas. Ceci a pour effet de diriger le sac de sécurité gonflable vers votre poitrine plutôt que vers votre tête et votre cou.

Réglez votre siège selon ces recommandations de la NHTSA, tout en conservant le contrôle des pédales, du volant de direction et la vue des commandes du tableau de bord.

## ⚠ ATTENTION

### ■ Précautions à observer avec les sacs de sécurité gonflables SRS



- Si vous attachez une rallonge de ceinture de sécurité à la boucle du siège conducteur, mais pas à la ceinture de sécurité proprement dite, le système de sac de sécurité gonflable SRS conducteur pense que vous avez attaché votre ceinture de sécurité, alors qu'en fait c'est faux. Dans ce cas, il se peut que le sac de sécurité gonflable conducteur ne se déploie pas correctement en cas d'accident, et vous risquez d'être tué ou grièvement blessé. Veillez donc à porter la ceinture de sécurité avec la rallonge de ceinture de sécurité.
- Le sac de sécurité gonflable SRS passager avant se déploie également avec une violence considérable, qui peut être très dangereuse voire mortelle si le passager avant se trouve très près du sac de sécurité gonflable. Éloignez le siège passager avant au maximum du sac de sécurité gonflable, et réglez le dossier de siège de sorte à être assis bien droit dans le siège.
- Les nourrissons et les enfants qui ne sont pas correctement assis et/ou protégés peuvent être grièvement blessés ou tués par le déploiement d'un sac de sécurité gonflable. Installez les enfants trop jeunes pour pouvoir utiliser la ceinture de sécurité dans un siège de sécurité enfant. Lexus recommande vivement d'installer tous les nourrissons et enfants aux places arrière du véhicule et de prévoir pour eux des systèmes de retenue adaptés. Les sièges arrière sont plus sûrs pour les nourrissons et les enfants que le siège passager avant.
- N'installez jamais un siège de sécurité enfant type dos à la route sur le siège passager avant, même si le témoin "AIR BAG OFF" est allumé. En cas d'accident, la force de déploiement rapide du sac de sécurité gonflable passager avant peut grièvement, voire mortellement blesser l'enfant si le siège de sécurité enfant type dos à la route est installé sur le siège passager avant.

## ⚠ ATTENTION

### ■ Précautions à observer avec les sacs de sécurité gonflables SRS



- Ne vous asseyez pas sur le bord du siège et ne vous appuyez pas contre la planche de bord.



- Ne laissez pas un enfant rester debout devant le sac de sécurité gonflable SRS passager avant ou bien s'asseoir sur les genoux du passager avant.



- Ne laissez pas les occupants des sièges avant voyager avec un objet sur les genoux.
- Ne vous appuyez pas contre la porte, contre le rail latéral de toit ou contre les montants avant, latéraux et arrière.



- Interdisez à quiconque de s'agenouiller sur les sièges passagers en appui contre la porte ou de sortir la tête ou les mains à l'extérieur du véhicule.



## ! ATTENTION

### ■ Précautions à observer avec les sacs de sécurité gonflables SRS

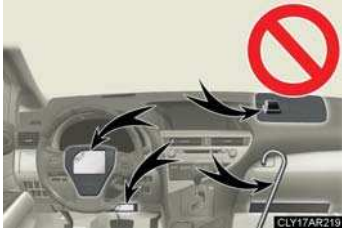

- Ne fixez ni ne posez aucun objet sur la planche de bord, la garniture centrale du moyeu de volant de direction ou la partie inférieure du tableau de bord.  
Au déploiement des sacs de sécurité gonflables SRS conducteur, passager avant et genoux, tout objet risque de se transformer en projectile.
- Ne fixez aucun objet sur les portes, la vitre de pare-brise, les vitres latérales, les montants avant et arrière, le rail latéral de toit et la poignée de maintien.
- Ne suspendez aux crochets à vêtements aucun cintre nu ni aucun objet dur. En cas de déploiement des sacs de sécurité gonflables rideau SRS, tous ces objets pourraient se transformer en projectiles et causer des blessures graves, voire mortelles.
- Si un cache en vinyle est mis dans la zone où les sacs de sécurité gonflable SRS de genoux se déploie, assurez-vous de l'enlever.
- N'utilisez aucun accessoire de siège venant recouvrir les zones de déploiement des sacs de sécurité gonflables SRS latéraux, car il risquerait d'en gêner le déploiement. De tels accessoires peuvent empêcher les sacs de sécurité gonflables latéraux de fonctionner correctement, désactiver le dispositif ou entraîner le déploiement accidentel des sacs de sécurité latéraux, entraînant la mort ou des blessures graves.
- Évitez de faire subir des chocs ou des pressions excessives aux zones renfermant les composants des sacs de sécurité gonflables SRS.  
En effet, cela pourrait entraîner un fonctionnement anormal des sacs de sécurité gonflables SRS.

## ATTENTION

### ■ Précautions à observer avec les sacs de sécurité gonflables SRS

- Ne touchez aucun composant du système immédiatement après le déclenchement (déploiement) des sacs de sécurité gonflables SRS, car ils sont alors encore très chauds.
- Si vous avez des difficultés à respirer après le déploiement des sacs de sécurité gonflables SRS, ouvrez une porte ou une vitre pour faire entrer de l'air frais, ou bien descendez du véhicule si cela ne présente pas de danger. Essayez tout résidu dès que possible afin d'éviter d'éventuelles irritations de la peau.
- Si les parties renfermant les sacs de sécurité gonflables SRS, telles que la garniture du moyeu de volant et les garnitures de montants avant et arrière, apparaissent abîmées ou craquelées, faites-les remplacer par votre concessionnaire Lexus.
- Ne rien disposer sur le siège du passager avant, comme un coussin par exemple. Le poids du passager s'en trouve réparti sur toute la surface de l'assise, ce qui empêche le capteur de détecter correctement le poids. En conséquence, le sac de sécurité gonflable SRS passager avant risque de ne pas se déployer en cas de choc.



## ATTENTION

### ■ Modification et mise au rebut des éléments du système de sacs de sécurité gonflables SRS

Consultez impérativement votre concessionnaire Lexus si vous avez besoin d'intervenir sur votre véhicule ou de procéder à l'une des modifications suivantes. Les sacs de sécurité gonflables SRS risquent de ne pas fonctionner correctement ou de se déployer (gonfler) accidentellement, provoquant ainsi des blessures graves, voire mortelles.

- Installation, dépose, démontage et réparations des sacs de sécurité gonflables SRS
- Réparations, modifications, démontage ou remplacement du volant, du tableau de bord, de la planche de bord, des sièges ou de leur garnissage, des montants avant, latéraux et arrière ou des rails latéraux de toit
- Réparations ou modifications de l'aile avant, du bouclier avant ou du côté de l'habitacle
- Installation de chasse-neige, de treuils, etc., sur la calandre (pare-buffle ou pare-kangourou, etc.)
- Modification des suspensions du véhicule
- Installation d'appareils électroniques, tels qu'un radioémetteur/récepteur ou d'un lecteur CD
- Aménagements du véhicule visant à permettre sa conduite par une personne atteinte d'un handicap physique



## Abbreviation list

# Abbreviation/Acronym list

ABBREVIATIONS	MEANING
2WD	Two Wheel Drive
4WD	Four Wheel Drive
A/C	Air Conditioning
ABS	Anti-lock Brake System
AFS	Adaptive Front-lighting System
AI-SHIFT	Artificial Intelligence Shift control
ALR	Automatic Locking Retractor
AWD	All Wheel Drive
CRS	Child Restraint System
DISP	Display
ECT	Electronic Controlled Transmission
ECU	Electronic Control Unit
EDR	Event Data Recorder
ELR	Emergency Locking Retractor
EPS	Electric Power Steering
GAWR	Gross Axle Weight Ratings
GCWR	Gross Combination Weight Rating
GVWR	Gross Vehicle Weight Rating
I/M	Emission Inspection and Maintenance
LATCH	Lower Anchors and Tethers for Children
LED	Light Emitting Diode
MMT	Methylcyclopentadienyl Manganese Tricarbonyl
M + S	Mud and Snow

ABBREVIATIONS	MEANING
MTBE	Methyl Tertiary Butyl Ether
PCS	Pre-Collision System
PWR	Power
SRS	Supplemental Restraint System
TIN	Tire Identification Number
TPMS	Tire Pressure Warning System
TRAC	Traction Control
VDIM	Vehicle Dynamics Integrated Management
VIN	Vehicle Identification Number
VSC	Vehicle Stability Control

**A** A/C  
    Air conditioning filter .....493  
ABS..... 231  
ACCESSORY mode ..... 153  
Active torque control  
    AWD mode .....231  
AFS .....186  
Adaptive front lighting system ..... 186  
Air conditioning filter .....493  
Air conditioning system .....274  
Automatic air conditioning  
    system.....274

**Airbags**  
Airbag operating conditions .....113  
Airbag precautions for your  
    child .....117  
Airbag warning light ..... 536  
Curtain shield airbag operating  
    conditions .....113  
Curtain shield airbag  
    precautions .....117  
Front passenger occupant  
    classification system .....122  
General airbag precautions .....117  
Locations of airbags .....109  
Modification and disposal of  
    airbags.....121  
Proper driving posture .....107, 117  
Side airbag operating  
    conditions .....113  
Side airbag precautions.....117  
SRS airbags .....109

Alarm .....	103
Anti-lock brake system.....	231
Armrest.....	418
Audio input .....	337
Audio system	
Audio input.....	337
AUX port.....	337
CD player/changer .....	297
iPod .....	317
MP3/WMA disc.....	307
Optimal use.....	334
Portable audio device.....	337
Radio.....	287
Steering wheel audio switch.....	339
USB memory .....	325
USB port.....	325

Automatic air conditioning system	
Air conditioning filter.....	493
Air conditioning system.....	274
Automatic headlight leveling	
system .....	188
Automatic high beam system.....	189
Automatic light control system.....	184
Automatic transmission	
Automatic transmission .....	159
If the shift lever cannot be	
shifted from P .....	579
S mode.....	161
AUX port.....	337



<b>B</b>	<b>Back door</b>	
	Back door.....	50
	Wireless remote control.....	43
	<b>Back-up lights</b>	
	Wattage.....	605
	<b>Battery</b>	
	Checking.....	474
	If the vehicle has a	
	discharged battery.....	584
	Preparing and checking	
	before winter.....	254
	Bluetooth® audio.....	342
	Bluetooth® phone.....	362
	<b>Brake</b>	
	Fluid.....	601
	Parking brake.....	164
	Brake assist.....	231
	Break-in tips.....	145

<b>C</b>	<b>Care</b>	
	Exterior.....	444
	Interior.....	447
	Seat belts.....	448
	<b>Cargo hooks</b> .....	421
	<b>CD changer</b>	
	CD.....	297
	MP3.....	307
	WMA disc.....	307
	<b>CD player</b> .....	297
	<b>Chains</b> .....	254

**Child restraint system**

Booster seats, definition..... 127  
 Booster seats, installation..... 134  
 Convertible seats, definition..... 127  
 Convertible seats, installation..... 134  
 Front passenger occupant  
     classification system ..... 122  
 Infant seats, definition ..... 127  
 Infant seats, installation..... 134  
 Installing CRS with LATCH  
     anchors ..... 132  
 Installing CRS with seat belts ..... 134  
 Installing CRS with top tether  
     straps..... 138

**Child safety**

Airbag precautions ..... 117  
 Back door precautions ..... 56  
 Battery precautions ..... 475, 586  
 Child restraint system ..... 127  
 Child-protectors ..... 48  
 How your child should wear  
     the seat belt ..... 79  
 Installing child restraints..... 131  
 Moon roof precautions..... 96  
 Power window lock switch..... 90  
 Power window precautions ..... 92  
 Removed electronic key battery  
     precautions..... 497  
 Seat belt comfort guide ..... 76  
 Seat belt extender precautions..... 82  
 Seat belt precautions ..... 80  
 Seat heater precautions..... 417  
 Child-protectors ..... 48

Cleaning  
 Exterior ..... 444  
 Interior ..... 447  
 Seat belts ..... 448  
 Clock ..... 410  
 Coat hooks ..... 419  
 Compass ..... 432  
 Condenser ..... 472  
 Console box ..... 404  
 Cooling system  
     Engine overheating ..... 587  
 Cornering assist sensors ..... 220  
 Cruise control  
     Cruise control ..... 204  
     Dynamic radar cruise control ..... 208  
 Cup holders ..... 402  
 Curtain shield airbags ..... 109  
 Customizable features ..... 621

**D** Daytime running light system ..... 187  
 Defogger  
     Rear window ..... 281  
     Side mirrors ..... 87  
 Dimensions ..... 594  
 Dinghy towing ..... 270  
 Display  
     Multi-information display ..... 173  
     Trip information ..... 176  
     Warning message ..... 545  
 Do-it-yourself maintenance ..... 457  
 Door courtesy lights  
     Door courtesy lights ..... 396  
     Wattage ..... 605  
 Door lock  
     Back door ..... 50  
     Side door ..... 47  
     Wireless remote control ..... 43  
 Door pockets ..... 401  
 Doors  
     Back door ..... 50  
     Door windows ..... 90  
     Door lock ..... 31, 43, 47  
     Power back door ..... 50  
     Side door ..... 47  
     Side mirrors ..... 87  
 Driver's seat belt reminder light ..... 537  
 Driving  
     Break-in tips ..... 145  
     Correct posture ..... 107  
     Utility vehicle precautions ..... 244  
     Procedures ..... 144  
     Winter driving tips ..... 254  
 Driving position memory ..... 70

<b>E</b>	Electric power steering .....	231
	Electronic features control .....	173
	Electronic key	
	If the electronic key does not operate properly .....	581
	Emergency flasher switch .....	524
	Emergency, in case of	
	If the electronic key does not operate properly .....	581
	If the engine will not start .....	577
	If the shift lever cannot be shifted from P .....	579
	If the vehicle has a discharged battery .....	584
	If a warning buzzer sounds .....	535
	If a warning light turns on .....	535
	If a warning message is displayed .....	545
	If you have a flat tire .....	564
	If you lose your keys .....	580
	If you think something is wrong .....	531
	If your vehicle becomes stuck .....	590
	If your vehicle has to be stopped in an emergency .....	591
	If your vehicle needs to be towed .....	525
	If your vehicle overheats .....	587

Engine	
Accessory mode .....	153
Compartment .....	463
Engine switch .....	153
Hood .....	460
How to start the engine .....	153
Identification number .....	595
If the engine will not start .....	577
Ignition switch .....	153
Overheating .....	587
Engine compartment cover .....	464
Engine coolant	
Capacity .....	599
Checking .....	470
Preparing and checking before winter .....	254
Engine coolant temperature gauge .....	166
Engine immobilizer system .....	101
Engine oil	
Capacity .....	597
Checking .....	466
Preparing and checking before winter .....	254
Engine oil maintenance data .....	468
EPS .....	231
Event data recorder .....	533

<b>F</b>	Floor mat .....	420
	Fluid	
	Brake.....	601
	Washer.....	477
	Fog lights	
	Switch.....	195
	Wattage.....	605
	Footwell lights .....	396
	Front fog lights	
	Switch.....	195
	Wattage.....	605
	Front passenger occupant classification system .....	122
	Front passenger's seat belt reminder light.....	537
	Front seats	
	Adjustment.....	61
	Driver's seat position memory.....	70
	Flattening seatbacks.....	61
	Front side marker light	
	Replacing light bulbs.....	511
	Wattage.....	605
	Front turn signal lights	
	Replacing light bulbs.....	511
	Wattage.....	605
	Fuel	
	Capacity.....	596
	Fuel gauge .....	166
	Fuel pump shut off system .....	532
	Information.....	606
	Refueling .....	97
	Type.....	606
	Fuel door .....	97
	Fuel filler door .....	97
	Fuel pump shut off system.....	532
	Fuses .....	498

<b>G</b>	Garage door opener .....	426
	Gauges.....	166
	Glove box.....	400
<b>H</b>	Hands-free system for mobile phone.....	362
	Hazard lights switch .....	524
	Head-up display.....	179
	Head restraints	
	Adjustment .....	73
	Headlight aim.....	509
	Headlight cleaner.....	203
	Headlights	
	Discharge headlight precautions.....	522
	Replacing light bulbs.....	511
	Switch.....	184
	Wattage.....	605
	Head-up display.....	179
	Heaters	
	Seat heaters .....	416
	Side mirrors.....	281
	Hill-start assist control.....	238
	Hood.....	460
	Hooks	
	Cargo.....	421
	Coat.....	419
	HUD .....	179
	Horn.....	165

<b>I</b>	I/M test .....	456
	Identification	
	Engine .....	595
	Vehicle .....	595
	Ignition switch .....	153
	Illuminated entry system .....	396
	Indicator lights .....	168
	Initialization	
	Items to initialize .....	630
	Inside rear view mirror .....	85
	Interior lights	
	Interior lights .....	396
	Switch .....	397
	Wattage .....	605

<b>J</b>	Jack	
	Positioning a floor jack .....	461
	Replacing the wheel .....	564
	Jack handle .....	564

<b>K</b>	Keyless entry .....	43
	Keys	
	Electronic key .....	26
	Engine switch .....	153
	If the electronic key does not operate properly .....	581
	If you lose your keys .....	580
	Ignition switch .....	153
	Key number .....	26
	Keyless entry .....	43
	Keys .....	26
	Mechanical key .....	27
	Wireless remote control key .....	43

<b>L</b>	<b>Light bulbs</b>	
	Replacing.....	511
	Wattage.....	605
	<b>Lights</b>	
	Door courtesy lights.....	396
	Emergency flasher switch.....	524
	Fog light switch.....	195
	Hazard lights switch.....	524
	Headlight switch.....	184
	Interior light switch.....	397
	Luggage compartment light.....	53
	Outer foot lights.....	396
	Overhead courtesy light.....	396
	Personal light switch.....	397
	Replacing light bulbs.....	511
	Scuff lights.....	396
	Shift lever light.....	396
	Turn signal lever.....	163
	Vanity lights.....	409
	Wattage.....	605
	<b>Load capacity.....</b>	<b>253</b>
	<b>Lock steering column.....</b>	<b>156</b>
	<b>Luggage compartment lights</b>	
	Switch.....	53
	Wattage.....	605
	<b>Luggage cover.....</b>	<b>423</b>

<b>M</b>	<b>Maintenance</b>	
	Do-it-yourself maintenance.....	457
	General maintenance.....	452
	Maintenance data.....	594
	Maintenance requirements.....	450
	<b>Meter</b>	
	Instrument panel light control.....	167
	Meters.....	166
	<b>Mirrors</b>	
	Inside rear view mirror.....	85
	Side mirror heaters.....	281
	Side mirrors.....	87
	Vanity mirrors.....	409
	<b>Moon roof.....</b>	<b>93</b>
	<b>MP3 disc.....</b>	<b>307</b>
	<b>Multi-information display.....</b>	<b>173</b>
<b>N</b>	<b>Noise from under vehicle.....</b>	<b>22</b>
<b>O</b>	<b>Odometer.....</b>	<b>166</b>
	<b>Oil</b>	
	Engine oil.....	466
	<b>Opener</b>	
	Back door.....	50
	Fuel filler door.....	97
	Hood.....	460

Outer foot lights	
Outer foot lights.....	396
Wattage.....	605
Outside rear view mirrors	
Adjusting and folding.....	87
Mirror position memory.....	70
Outside temperature display.....	411
Overhead console.....	406
Overhead courtesy lights	
Overhead courtesy lights.....	396
Wattage.....	605
Overheating, Engine.....	587
<b>P</b> Parking assist sensors.....	220
Parking brake.....	164
Parking lights	
Replacing light bulbs.....	511
Switch.....	184
Wattage.....	605
PCS.....	240
Personal lights	
Switch.....	397
Power back door.....	50
Power outlet.....	413
Power windows.....	90
Pre-collision system.....	240
<b>R</b> Radar cruise control.....	208
Radiator.....	472
Radio.....	287
Rear seat	
Folding down.....	66
Seat adjustment.....	66
Rear turn signal lights	
Replacing light bulbs.....	512
Wattage.....	605
Rear view mirror	
Compass.....	432
Rear view monitor system.....	227
Rear window defogger.....	281
Rear window wiper.....	202
Remote Touch*	
Replacing	
Electronic key battery.....	496
Fuses.....	498
Light bulbs.....	511
Tires.....	564
Wireless remote control battery.....	496
Roof luggage carrier.....	249
Reporting safety defects for U.S. owners.....	632

\*: Refer to the "Navigation System Owner's Manual".



<b>S</b>	Safety Connect.....	436	Service reminder indicators .....	168
	Scuff lights.....	396	Shift lever	
	<b>Seat belts</b>		Automatic transmission .....	159
	Adjusting the seat belt.....	76	If the shift lever cannot be	
	Automatic locking retractor.....	78	shifted from P.....	579
	Child restraint system		<b>Shift lever light .....</b>	<b>396</b>
	installation .....	131	<b>Shift lock system.....</b>	<b>579</b>
	Cleaning and maintaining		<b>Side airbags .....</b>	<b>109</b>
	the seat belts.....	448	<b>Side marker lights</b>	
	Emergency locking retractor .....	78	Switch.....	184
	How to wear your seat belt.....	75	<b>Side mirror</b>	
	How your child should wear		Adjusting and folding.....	87
	the seat belt.....	79	Mirror position memory.....	70
	Pregnant women,		<b>Smart access system with</b>	
	proper seat belt use.....	78	<b>push-button start</b>	
	Reminder light.....	537	Entry function .....	31
	Seat belt extenders .....	79	Starting the engine.....	153
	Seat belt pretensioners.....	77	<b>"SOS" button.....</b>	<b>436</b>
	<b>Seat heaters .....</b>	<b>416</b>		
	<b>Seats</b>			
	Adjustment .....	61, 66		
	Adjustment			
	precautions .....	65, 68		
	Child seats/child restraint			
	system installation .....	131		
	Cleaning.....	447		
	Head restraint.....	73		
	Properly sitting in the seat.....	107		
	Seat heaters.....	416		
	Seat position memory.....	70		

<b>Spare tire</b>	
Inflation pressure .....	487
Spare tire .....	564
<b>Spark plug</b> .....	<b>599</b>
<b>Specifications</b> .....	<b>594</b>
<b>Speedometer</b> .....	<b>166</b>
<b>Steering wheel</b>	
Adjustment .....	83
Audio switches .....	339
Power easy access system .....	63
Steering wheel position memory .....	70
<b>Storage feature</b> .....	<b>399</b>
<b>Stuck vehicle</b>	
If your vehicle becomes stuck ....	590
<b>Sun visors</b> .....	<b>408</b>
<b>Sunshades</b>	
Roof .....	94

<b>Switch</b>	
Display contrast adjustment switch .....	179
Display position adjustment switch .....	179
ECT SNOW switch .....	160
Emergency flasher switch .....	524
Engine switch .....	153
ENTER switch .....	173
Fog light switch .....	195
Hazard light switch .....	524
Head-up display main switch button .....	179
Ignition switch .....	153
Light switches .....	184
Menu switch .....	173
Power back door opener .....	50
Power door lock switch .....	47
Power window switch .....	90
Window lock switch .....	90
Wiper and washer switch .....	197

<b>T</b>	Tachometer.....	166
	Tail lights	
	Replacing light bulbs.....	512
	Switch.....	184
	Wattage.....	605
	Theft deterrent system	
	Alarm.....	103
	Engine immobilizer system.....	101
	Tire inflation pressure.....	487
	Tire information	
	Glossary.....	615
	Size.....	612
	Tire identification number.....	611
	Uniform tire quality grading.....	613
	Tires	
	Chains.....	254
	Checking.....	478
	If you have a flat tire.....	564
	Inflation pressure.....	487
	Inflation pressure sensor.....	479
	Information.....	609
	Replacing.....	564
	Rotating tires.....	478
	Size.....	602
	Snow tires.....	254
	Spare tire.....	565
	Tire pressure warning system.....	479, 537
	Tools.....	564
	Total load capacity.....	253

	Towing	
	Emergency towing.....	526
	Trailer towing.....	258
	TRAC.....	231
	Traction control.....	231
	Trip information display.....	173
	Trip meter.....	166
	Turn signal lights	
	Replacing light bulbs.....	511
	Switch.....	163
	Wattage.....	605
<b>U</b>	USB port.....	325

V

Vanity lights  
 Vanity lights ..... 409  
 Wattage ..... 605  
 Vanity mirrors ..... 409  
 VDIM ..... 231  
 Vehicle dynamics integrated  
   management ..... 231  
 Vehicle identification number ..... 595  
 Vehicle stability control ..... 231  
 VSC ..... 231

W

Warning buzzers  
 Brake system ..... 535  
 Open door ..... 537  
 Seat belt reminder ..... 537  
 Warning lights  
 Anti-lock brake system ..... 536  
 Brake assist system ..... 536  
 Brake system ..... 535  
 Charging system ..... 535  
 Electric power steering ..... 536  
 Electronic engine control  
   system ..... 536  
 Low fuel level ..... 537  
 Low tire pressure ..... 537  
 Malfunction indicator lamp ..... 536  
 Master warning light ..... 537  
 Open door ..... 537  
 Pre-collision system ..... 536  
 Pretensioners ..... 536  
 Seat belt reminder light ..... 537  
 Slip indicator ..... 536  
 SRS airbags ..... 536  
 Tire pressure ..... 537

Warning messages

Adaptive front lighting system ..... 547  
 Automatic transmission fluid ..... 547  
 Anti-lock brake system ..... 547  
 AWD system ..... 546, 547, 551  
 Brake lamp system ..... 547  
 Brake system ..... 545  
 Dynamic radar cruise  
   control system ..... 547, 551  
 Electric power steering ..... 547  
 Engine oil maintenance ..... 551  
 Engine oil pressure ..... 546  
 Engine overheat ..... 551  
 Headlight leveling ..... 547  
 Hood ..... 551  
 Intuitive parking assist ..... 551, 547  
 Low fuel ..... 551  
 Moon roof ..... 551  
 Open door ..... 551  
 Parking brake ..... 551  
 Pre-collision system ..... 547, 551  
 Smart access system with  
   push-button start ..... 556  
 SRS airbags ..... 547  
 Steering lock ..... 547  
 Washer fluid ..... 551

<b>Washer</b>	
Checking .....	477
Preparing and checking	
before winter .....	254
Switch .....	197
<b>Washing and waxing .....</b>	<b>444</b>
<b>Weight</b>	
Load limits .....	253
Weight .....	594
<b>Wheels .....</b>	<b>491</b>
<b>Window glasses .....</b>	<b>90</b>
<b>Window lock switch .....</b>	<b>90</b>
<b>Windows</b>	
Power windows.....	90
Rear window defogger .....	281
Washer.....	197
<b>Windshield wiper de-icer.....</b>	<b>282</b>
<b>Windshield wipers.....</b>	<b>197</b>
<b>Wireless remote control key</b>	
Replacing the battery .....	496
<b>WMA disc .....</b>	<b>307</b>

## What to do if... What to do if...



A tire punctures

P. 564 If you have a flat tire



The engine does not start

P. 577 If the engine will not start

P. 101 Engine immobilizer system

P. 584 If the battery is discharged



The shift lever cannot be moved out

P. 579 If the shift lever cannot be shifted from P



The engine coolant temperature gauge enters the red zone

P. 587 If your vehicle overheats



Steam can be seen coming from under the hood



The key is lost

P. 580 If you lose your keys



The battery runs out

P. 584 If the battery is discharged



The doors cannot be locked

P. 47 Side doors

P. 50 Back door



The horn begins to sound

P. 103 Alarm



The vehicle is stuck in mud or sand

P. 590 If the vehicle becomes stuck



A warning light or indicator light comes on

P. 535

If a warning light turns on or a warning buzzer sounds...



n Warning lights



Brake system warning light

or



P. 535



ABS warning light

or



P. 536



Low fuel level warning light

P. 537



SRS warning light

P. 536



Open door warning light

P. 537



Charging system warning light

P. 535



Malfunction indicator lamp

or



P. 536



Driver's seat belt reminder light

P. 537



Front passenger's seat belt reminder light

P. 537



Master warning light

P. 537



Electric power steering system warning light

P. 536



Pre-collision system warning light

P. 536



Tire pressure warning light

P. 537



Slip indicator

P. 536



## GAS STATION INFORMATION

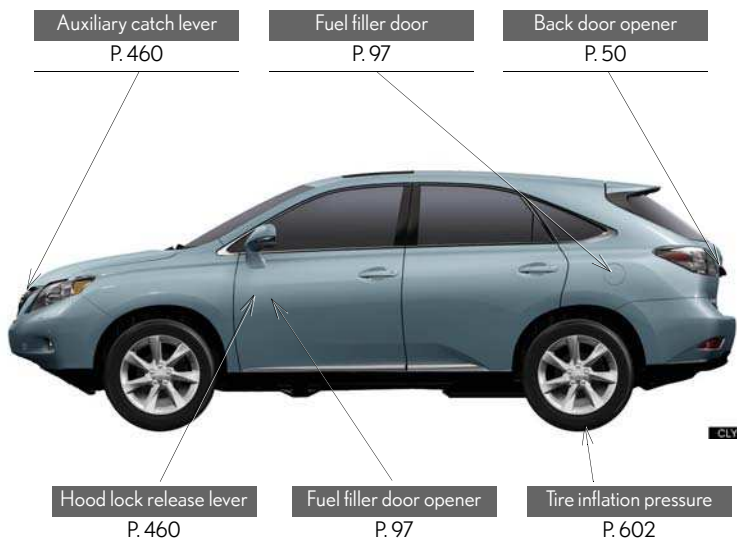

Fuel tank capacity	19.2 gal. (72.5 L, 15.9 Imp. gal.)	
Fuel type	Unleaded gasoline only	P. 596
Cold tire inflation pressure		P. 602
Engine oil capacity (Drain and refill — reference)	With filter Without filter	qt. (L, Imp. qt.) 6.4 (6,1, 5,3) 6.0 (5,7, 5,0)
Engine oil type	Toyota Genuine Motor Oil or equivalent Oil grade: ILSAC multigrade engine oil Recommended oil viscosity: SAE 0W-20	P. 597



2011

**RX 350**

## WARRANTY AND SERVICES GUIDE

Owner Amenities | Warranty Information | Maintenance Requirements

## **AUTHORIZED DEALERSHIP MAINTENANCE AND REPAIRS**

Lexus recommends having maintenance and repairs for your vehicle performed by an authorized Lexus dealership. To locate your nearest authorized Lexus dealership, log on to [www.lexus.com](http://www.lexus.com) or contact Lexus Customer Satisfaction at (800) 255-3987.

From everyone at Lexus, thank you for purchasing one of our vehicles. Your Lexus is designed to deliver uncompromising luxury and performance. We are committed to providing you with an ownership experience that is second to none, and we look forward to serving you in the years ahead. Welcome to the Lexus family!

## **Taking Delivery of Your New Lexus**

As you take delivery of your new vehicle, there are some important services you should know about. These include:

**Lexus Personalized Settings:** Your vehicle includes a variety of electronic features that can be personalized to your preferences. For example, doors can be programmed to remain locked when you shift into "Park." See your dealer for details.

**Pre-Delivery Service:** Your dealership has performed a thorough service to prepare your vehicle for delivery. This includes initializing certain electronic features, such as the one-touch power windows.

**Scheduled Maintenance:** Your vehicle requires maintenance every six months or 5,000 miles, whichever comes first. See page 44 for details.

**Dealership Service Department:** Your service department is committed to helping you keep your Lexus performing at its best. Your dealer will provide you with the department's hours of operation, appointment procedures and information on any special services.

**Warranty Coverage:** Your Lexus is covered by one of the finest warranties in the industry. See page 15 for a summary of coverages.

**Roadside Assistance:** Roadside assistance is provided for 48 months from your vehicle's in-service date, regardless of mileage. See page 6 for details.

Again, thank you for choosing Lexus. We wish you many years of safe and pleasurable driving.

## OWNER AMENITIES

### Complimentary Services

First Scheduled Maintenance Service .....	4
Second Scheduled Maintenance Service .....	4
Loaner Vehicle .....	5
Travel Protection .....	5
Roadside Assistance .....	6

### Other Benefits and Assistance

Quality Control .....	7
Vehicle Service History .....	7
Vehicle Service Agreements .....	7
Body Repairs .....	7
The Smart Key .....	8

## WARRANTY INFORMATION

### Introduction

If You Need Assistance .....	9
The Lexus Commitment .....	14
Warranty Coverages at a Glance .....	15

### Your Warranties in Detail

General Warranty Provisions .....	16
New Vehicle Limited Warranty .....	18
Federal Emission Control Warranty .....	22

California Emission Control Warranty ..... 28

Tire Limited Warranty ..... 34

**Your Responsibilities**

Operation and Maintenance ..... 35

Obtaining Warranty Service ..... 37

**MAINTENANCE INFORMATION**

**Introduction**

The Importance of Scheduled Maintenance ..... 39

Maintenance and Lexus Warranty Coverage ..... 40

Lexus Dealership Service ..... 41

General Maintenance and Regular Use ..... 42

**Scheduled Maintenance Log**

Determining Your Maintenance Interval: Months vs. Mileage ..... 44

Special Operating Conditions ..... 44

Complimentary First Scheduled Maintenance Service ..... 45

Complimentary Second Scheduled Maintenance Service ..... 46

Scheduled Maintenance Log ..... 48

Explanation of Maintenance Items ..... 68

Vehicle Identification ..... 73

**INDEX** ..... 74

To help ensure that your ownership experience is pleasant, convenient and trouble-free, Lexus provides you with a variety of complimentary services. These services are described on the following pages. Other valuable owner benefits are described in the section entitled “Other Benefits and Assistance” beginning on page 7.

### **First Scheduled Maintenance Service: Six Months or 5,000 Miles**

This complimentary service is performed at six months or 5,000 miles, whichever occurs first. To obtain this service, contact your Lexus dealership. Your complimentary service will include these items:

- Inspect and adjust all fluid levels
- Program Lexus Personalized Settings, if requested
- Reset maintenance reminder light
- Rotate tires
- Visually inspect brake pads, calipers and rotors
- Check installation of driver’s floor mat
- Road-test vehicle

### **What are Lexus Personalized Settings?**

Your vehicle includes a variety of electronic features that can be programmed to your preferences. For example, doors can be programmed to remain locked when you shift into “Park.” (For more information, see the “Customizable Features” section of the Specifications chapter in your *Owner’s Manual*.) Programming of these features is performed once at no charge, provided you obtain the service at the six-month/5,000-mile scheduled maintenance service. Programming of your Lexus Personalized Settings requires special equipment and may be performed only by an authorized Lexus dealership.

### **Second Scheduled Maintenance Service: 12 Months or 10,000 Miles**

This complimentary service is performed at 12 months or 10,000 miles, whichever occurs first. To obtain this service, contact your Lexus dealership. Your complimentary service will include these items:

- Replace engine oil with 0W-20 oil; replace oil filter

- Reset maintenance reminder light
- Rotate tires
- Visually inspect brake pads, calipers and rotors
- Check installation of driver's floor mat
- Road-test vehicle

If you do the majority of your driving under certain special operating conditions, additional items are included in this service. See the "12 Months or 10,000 Miles" chart on page 48.

### **Loaner Vehicle**

If your vehicle must be kept overnight at a Lexus dealership for a warranty-covered condition that requires more than eight hours to repair, Lexus will provide you with a complimentary loaner vehicle for up to five days.

### **Travel Protection**

Lexus will reimburse for a rental car for up to five days and for overnight lodging for up to three nights (not to exceed \$200 per night) if all of the following occur:

- Your vehicle becomes inoperable or unsafe to drive when you are more than 100 miles from home.
- Your vehicle's malfunction is caused by a warranty-covered condition.
- Repairs will take longer than eight hours to complete.

To obtain reimbursement for rental car and lodging expenses, contact a Lexus dealership service consultant.



### Roadside Assistance

Lexus roadside assistance coverage is for 48 months from your vehicle's in-service date, regardless of mileage. Coverage is provided 24 hours a day, 365 days a year, for vehicles operated in the United States, U.S. territories and Canada. Assistance is administered through the American Automobile Association.

### Services Provided

- Roadside services such as battery jump-start, tire change, fuel delivery, vehicle extrication and towing in case of minor accident.
- Towing to the nearest Lexus dealership (or an alternate repair facility, if necessary).
- Assistance in locating alternate transportation and lodging.

### How to Get Help

To obtain roadside assistance, take the following steps:

- 1) Call (800) 25-LEXUS (800/255-3987).
- 2) Have as much of the following information as possible:
  - 17-digit Vehicle Identification Number (VIN) found on the vehicle registration paperwork and on the certification label located inside the driver's door jamb
  - Owner's name and home address
  - Vehicle license plate number
  - Location of vehicle, including the nearest major intersection
- 3) Wait at your vehicle or in a nearby secure location for the roadside assistance provider to arrive.

### Additional Coverage

After your roadside assistance coverage expires, you may join a motor club created exclusively for Lexus owners. Benefits include roadside assistance coverage, a trip-planning service and discounts on travel and dining. For further information, call (800) 25-LEXUS.

## Quality Control

You may have noticed a few miles on the odometer when you took delivery of your Lexus. This mileage is a result of the comprehensive process used to ensure the quality of your vehicle. This process includes extensive inspections during and after production. The final inspection takes place at the selling dealership and includes a road-test conducted by a trained Lexus technician.

If you'd like to know more about Lexus quality-control procedures, ask a Lexus dealership service consultant.

## Vehicle Service History

When you have your vehicle serviced at a Lexus dealership, your service information is recorded in the Lexus National Service History database. This is the first database of its kind in the automotive industry. It can be accessed by any Lexus dealership in the United States – a great convenience if you relocate or need to have your vehicle serviced while traveling.

## Vehicle Service Agreements

If you plan to keep your vehicle for several years or if you accumulate mileage quickly, you may want to purchase a Lexus vehicle service agreement. These agreements cover the

cost of specific repairs beyond the factory warranty period. They also cover services such as towing, substitute transportation and lodging to minimize your inconvenience should your vehicle require repair. Lexus vehicle service agreements are available with a variety of coverage options. A Lexus dealership sales consultant can help you select the plan that's best for you.

## Body Repairs

If you're involved in a collision, you want your vehicle to be returned to its pre-accident condition when repaired. That's why it is important to make sure repairs are made only with Genuine Lexus Parts. Some repair shops and insurance companies may suggest using imitation or salvaged parts to save money. However, these parts do not meet Lexus' high standards for quality, fit and corrosion resistance. In addition, imitation and salvaged parts (and any damage or failures they may cause) are not covered by any Lexus warranty.

The best way to ensure that your vehicle is repaired with Genuine Lexus Parts is to take it to a Lexus dealership. Each dealership works with selected collision repair centers that meet Lexus' strict requirements for

training, equipment, quality and customer satisfaction. These repair centers use Genuine Lexus Parts exclusively in the repair of Lexus vehicles.

### The Smart Key

Your Lexus vehicle was made with two “Smart Keys” and an aluminum key-number plate. Each Smart Key includes an electronic main key that has an integrated mechanical back-up key. The electronic key controls the remote-entry and theft-deterrent systems, enables the push-button start switch and controls the engine immobilizer. The mechanical key can be removed from the electronic key and used to operate the driver’s door lock, the glove box lock and the trunk lock (if equipped).

### Replacing the Key

Your Lexus dealer can generate replacement keys. Certain bonded/registered locksmiths may also be able to generate replacement keys. When ordering a new key, bring all keys for the vehicle to your dealership. If a Smart Key or the key-number plate is not available, a Lexus dealer or certain locksmiths can obtain the key code from a restricted-access database. These businesses

can also access a service utility to register the keys to the vehicle if all registered keys have been lost.

If you lock your key in your vehicle and do not have a spare, your dealer can make a new mechanical key from the code on the key-number plate. Certain bonded/registered locksmiths may also be able to generate a replacement mechanical key. If a Lexus dealer is not available, please refer to [www.aloa.org](http://www.aloa.org) to find a bonded/registered locksmith who performs high-security key service.

### Keeping the Key Safe

Replacing a Smart Key may be costly. We advise you to keep a spare Smart Key and the key-number plate in a safe place. If you record the key number in more than one place, do not record it in a way that can be easily identified and associated with the vehicle. For example, don’t leave the number somewhere that can be accessed by a valet. It is wise to keep a copy of the key number outside of the vehicle.

Both Lexus and your Lexus dealer are dedicated to serving your automotive needs. Your complete satisfaction is our first priority. Should you have a problem or concern, please take the following steps to ensure the quickest possible response:

### Step 1

Discuss the situation with a dealership manager, such as the service manager or customer satisfaction manager. If necessary, ask the dealership owner or general manager for assistance. In most cases, a satisfactory solution can be reached at this step.

### Step 2

If the dealership does not address your concern to your satisfaction, call the Lexus Customer Satisfaction Department at (800) 25-LEXUS (800/255-3987). In Canada, call (800) 26-LEXUS (800/265-3987). In Mexico, call 95-1-310-328-2075.

You may also write to us at:

Lexus Customer Satisfaction  
Department  
P.O. Box 2991  
Torrance, CA 90509-2991

Whether calling or writing, please provide the following information:

- 17-digit Vehicle Identification Number (VIN) found on the vehicle registration paperwork and on the certification label located inside the driver's door jamb
- Current vehicle mileage
- Name of your selling and servicing Lexus dealerships
- Your day and evening telephone numbers

### Step 3

If your concern has still not been resolved to your satisfaction, Lexus offers additional assistance through:

#### National Center for Dispute Settlement (NCDS)

P.O. Box 457

Mt. Clemens, MI 48046

(866) 272-4872

**Important:** You must use NCDS prior to exercising rights or seeking remedies available to you through a court action pursuant to the Magnuson-Moss Warranty Act. In addition, you must use NCDS if you are required to do so prior to exercising certain rights or seeking certain remedies available under the Lemon Laws of your state. See the *Lemon Law Guide* for specific requirements applicable in your state.

However, if your state law permits and if you choose to exercise rights and seek remedies that are not created by the Act, you need not use NCDS.

### NCDS Arbitration

#### What is the Dispute Settlement Program?

This program consists of local professionals who are trained and experienced in arbitration. The arbitrator(s) appointed by NCDS will arbitrate your case by reviewing the facts you present; having the vehicle inspected, if necessary; and promptly rendering a fair and equitable decision.

#### How much will it cost?

The service is provided at no cost to you. It is part of Lexus' effort to promptly and equitably resolve your concerns. The decision-maker is an impartial third party. The decision of the arbitrator(s) is binding on Lexus but not on you.

### What types of disputes are eligible?

NCDS resolves disputes involving Lexus product reliability and warranty performance that arise during the greater of 1) four years or 50,000 miles from the vehicle's in-service date, whichever is earlier; or 2) the applicable provision of the Lexus New Vehicle Limited Warranty. However, NCDS will not arbitrate 1) claims involving a vehicle used primarily for commercial purposes unless the Lemon Laws of your state cover vehicles used for commercial purposes; or 2) claims that an air bag failed to deploy or deployed when it should not have; or 3) disputes regarding fires and/or accidents and/or theft. Since there are other additional exclusions, please contact NCDS for further information on eligibility guidelines. You must file a request for arbitration with NCDS within six months of the expiration of the eligibility period, provided the concern or alleged defect was brought to the attention of Lexus or one of its dealers during the eligibility period.

### How long is the arbitration process?

The entire process – from the time NCDS receives your request for arbitration to the arbitrator's decision – is designed to take no more than 40 days. A decision may be delayed if:

- You fail to provide certain information required by NCDS.
- You fail to make your vehicle available for inspection by NCDS in a timely manner (if an inspection is required).

### How do I request arbitration?

To initiate arbitration, you must complete an NCDS customer claim form and mail it to NCDS. A claim form is included in the *Lemon Law Guide* located in your vehicle, or you may request a form by calling NCDS at (866) 272-4872. When you call, please have ready your vehicle identification number (VIN), the names of your selling and servicing dealerships, and the current mileage on your Lexus.

In addition to completing the customer claim form, please provide NCDS with the following information:

- Vehicle year, make, model, VIN, mileage and date of purchase.
- A brief description of your complaint and the actions you have taken to resolve it.
- What action or remedy you believe would resolve your problem.

If you are seeking reimbursement for repairs or incidental expenses, please provide copies of applicable receipts.

Send your request to:

National Center for Dispute Settlement  
P.O. Box 457  
Mt. Clemens, MI 48046

Upon receipt of your request, NCDS will contact you regarding the status of your case and supply you with additional details about the program.

### How does the arbitration process work?

When NCDS receives your request, it will be forwarded to the Lexus area office for response.

At the request of either party or the arbitrators, NCDS may schedule a technical inspection. This may include an inspection of the vehicle by an independent technical expert with a Lexus representative present. The technical expert will forward his or her evaluation to NCDS.

An oral hearing will be held prior to a decision being rendered. At this hearing, all relevant evidence is admissible. You and a Lexus representative will present both sides of the case to the NCDS arbitrator(s). You will each be given an equal opportunity to give testimony and provide documents. Then you will each be given an opportunity for rebuttal. After considering all testimony and documents, the arbitrator(s) will review the applicable legal standards and render a decision within 10 days.

A settlement satisfactory to all parties may be negotiated at any time during the process.

**What types of decisions are rendered, and how do I know if Lexus will abide by the decision of the arbitrator(s)?**

Arbitrated decisions are based on what the arbitrator(s) believe to be fair and equitable after applying the appropriate legal standards. Remedies include but are not limited to repairs; reimbursement for repairs and incidental expenses, such as towing costs; and repurchase or replacement of your vehicle.

The decision of the arbitrator(s) is binding on Lexus but not on you. Lexus must comply with the decision shortly after it is rendered, usually within 30 days of your acceptance of the decision. NCDS will contact you within 10 days of scheduled compliance to ensure that Lexus has complied in a timely manner.

**Are there limits to the scope of arbitrated decisions?**

Arbitrated decisions do not include:

- Attorney fees
- Punitive damages
- Multiple damages
- Consequential damages, other than incidental damages that you may be entitled to under law

**What other recourse do I have?**

If you are dissatisfied with the arbitrator's decision or Lexus' compliance, you may pursue any other legal remedies available to you, including small claims court. You should be aware that the decision of the arbitrator(s) is admissible as evidence in any legal proceedings concerning your vehicle.

**Is the Dispute Settlement Program subject to change?**

The information in this booklet about the program is correct as of the date of printing. However, the program may be changed without notice. Contact the Lexus Customer Satisfaction Department at (800) 255-3987 for the most current information concerning the Dispute Settlement Program.



You have purchased one of the finest vehicles built in the world today, and it is backed by one of the finest warranties in the industry. This excellent warranty coverage demonstrates not only our confidence in Lexus vehicles, but also our commitment to every Lexus customer. We're dedicated to ensuring that you enjoy exceptional quality, dependability and peace of mind throughout your ownership experience.

To further demonstrate our commitment to our customers' satisfaction, occasionally we may establish a special policy adjustment to pay for specific repairs that are no longer covered by warranty. When we establish such a policy adjustment, we mail details to all applicable owners on record. That's why it is important to send in the card at the back of this booklet if you change your address or if you have purchased your Lexus from a previous owner.

You've made a wise decision to purchase a Lexus. Your vehicle delivers world-class luxury and performance,

along with an unparalleled commitment from Lexus to ensuring your satisfaction. You can be confident – as we are – that you'll enjoy owning your Lexus as much as you enjoy driving it.

This section of the *Warranty and Services Guide* describes the terms of Lexus warranty coverage as well as general owner responsibilities. The section beginning on page 39 describes your vehicle's maintenance requirements. Be sure to review this information carefully, since proper maintenance is required to ensure that warranty coverage remains intact.

All warranty information is the latest available at the time of publication and, with the exception of the emission control warranties, is subject to change without notice.

# WARRANTY

## New Vehicle Limited Warranty

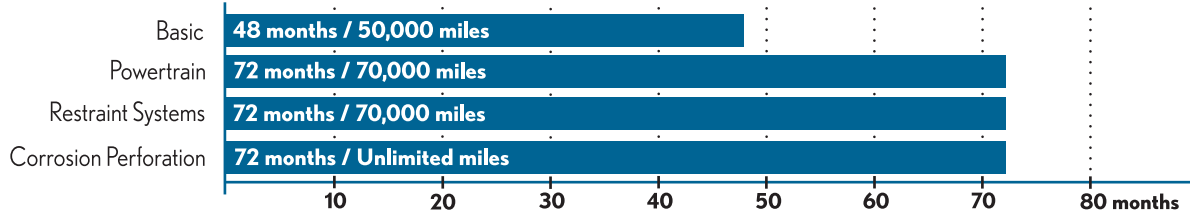

## Emission Control Warranty

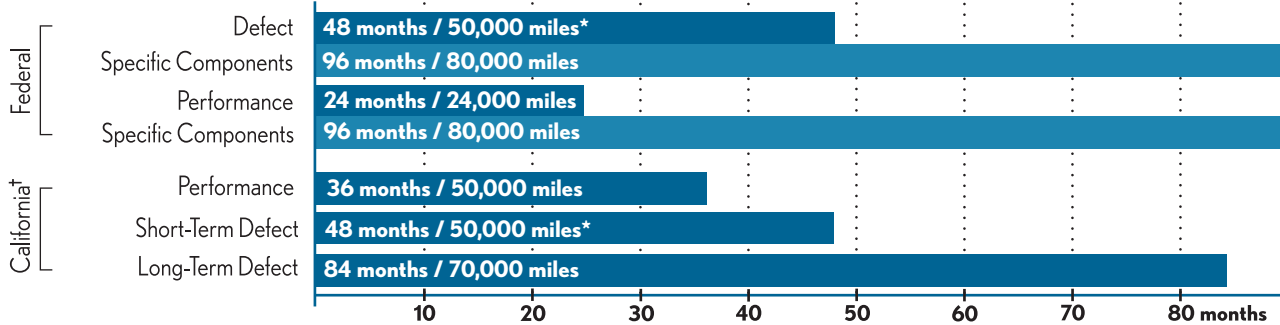

\*Specific components may have longer coverage under terms of the Powertrain Warranty.

†Also applies to Connecticut, Maine, Maryland, Massachusetts, New Jersey, New Mexico, Oregon, Pennsylvania, Rhode Island, Vermont and Washington vehicles equipped with a California Certified Emission Control System. Vehicles covered by this warranty are also covered by the Federal Emission Control Warranty.

### Who Is the Warrantor

The warrantor for these limited warranties is Lexus, a division of Toyota Motor Sales, U.S.A., Inc., 19001 South Western Avenue, Torrance, California 90509-2991, a California corporation.

### Which Vehicles Are Covered

These warranties apply to 2011 model-year Lexus RX 350 models registered and normally operated in the United States, U.S. territories and Canada. Warranty coverage is automatically transferred at no cost to subsequent vehicle owners.

### Multiple Warranty Conditions

This booklet contains warranty terms and conditions that may vary depending on the part covered. A warranty for specific parts or systems, such as the Powertrain Warranty or Emission Performance Warranty, is governed by the coverage set forth in that warranty as well as the General Warranty Provisions.

### When Warranty Begins

The warranty period begins on the vehicle's in-service date, which is the first date the vehicle is either delivered to an ultimate purchaser, leased, or used as a company car or demonstrator.

### Repairs Made at No Charge

Repairs and adjustments covered by these warranties are made at no charge for parts and labor.

### Parts Replacement

Any needed parts replacement will be made using new or remanufactured parts. The decision whether a part should be repaired or replaced will be made by the servicing Lexus dealership and/or Lexus. Parts scheduled to be replaced as required maintenance are warranted until their first replacement only.

**Note:** Lexus remanufactured parts meet or exceed all factory standards for safety, quality and reliability.

## Limitations

The performance of necessary repairs and adjustments is the exclusive remedy under these warranties or any implied warranties. Lexus does not authorize any person to create for it any other obligation or liability in connection with this vehicle.

**Any implied warranty of merchantability or fitness for a particular purpose is limited to the duration of these written warranties.** Some states do not allow restrictions on how long an implied warranty lasts, so this limitation may not apply to you.

## Your Rights Under State Law

These warranties give you specific legal rights. You may also have other rights that vary from state to state.

## WHAT IS COVERED AND HOW LONG

### Basic Warranty

This warranty covers repairs and adjustments needed to correct defects in materials or workmanship of any part supplied by Lexus, subject to the exceptions indicated under “What Is Not Covered” on pages 19–20.

Coverage is for 48 months or 50,000 miles, whichever occurs first, with the exception of wheel alignment and wheel balancing, which are covered for 12 months or 20,000 miles, whichever occurs first.

### Powertrain Warranty

This warranty covers repairs needed to correct defects in materials or workmanship of any component listed here and supplied by Lexus, subject to the exceptions indicated under “What Is Not Covered” on pages 19–20.

Coverage is for 72 months or 70,000 miles, whichever occurs first.

### Engine

Cylinder block and head and all internal parts, timing belt and cover, flywheel, oil pan, water pump, fuel pump, engine mounts, engine control computer, seals and gaskets.

### Transmission and Transaxle

Case and all internal parts, torque converter, clutch cover, mounts, engine control computer, seals and gaskets.

### Front-Wheel-Drive System

Drive shaft, axle, hub, bearings, seals and gaskets.

### Rear-Wheel-Drive System

Differential carrier assembly, drive shaft, axle carrier, axle case, axle bearing, axle shaft, seals and gaskets.

### Restraint Systems Warranty

This warranty covers repairs needed to correct defects in materials or workmanship of any seatbelt or air bag system supplied by Lexus, subject to the exceptions indicated under “What Is Not Covered” on pages 19–20.

Coverage is for 72 months or 70,000 miles, whichever occurs first.

For vehicles sold and registered in Kansas, the warranty for seatbelts and related components is 10 years, regardless of mileage.

### **Corrosion Perforation Warranty**

This warranty covers repair or replacement of any original body panel that develops perforation from corrosion (rust-through), subject to the exceptions indicated under “What Is Not Covered” on pages 19–20.

Coverage is for 72 months, regardless of mileage.

For information on how to protect your vehicle from corrosion, see the section entitled “Service Procedures and Specifications – Body” in the *Owner’s Manual*.

### **Towing**

When your vehicle is inoperable due to failure of a warranted part, towing service to the nearest authorized Lexus dealership is covered.

### **WHAT IS NOT COVERED**

This warranty does not cover damage or failures resulting directly or indirectly from any of the following:

- Fire, accidents or theft
- Abuse or negligence
- Misuse – for example, racing or overloading
- Improper repairs
- Alteration or tampering, including installation of non-Genuine Lexus Accessories
- Lack of or improper maintenance, including use of fluids other than those specified in the *Owner’s Manual*
- Installation of non-Genuine Lexus Parts
- Airborne chemicals, tree sap, road debris (including stone chips), rail dust, salt, hail, floods, wind storms, lightning and other environmental conditions
- Water contamination

This warranty also does not cover the following:

### **Tires**

Tires are covered by a separate warranty provided by the tire manufacturer. See page 34.

### **Normal Wear and Tear**

Noise, vibration, cosmetic conditions and other deterioration caused by normal wear and tear.

### **Maintenance Expense\***

Normal maintenance services such as engine tune-ups; replacement of fluids and filters; lubrication; cleaning and polishing; replacement of spark plugs and fuses; and replacement of worn wiper blades, brake pads/linings and clutch linings.

### **Vehicles With Altered Odometer**

Failure of a vehicle on which the odometer has been altered so that actual vehicle mileage cannot be readily determined.

### **Vehicles With Unknown Vehicle Identification Number**

Any vehicle for which the original factory-assigned vehicle identification number cannot be determined.

### **Salvage or Total-Loss Vehicles**

Any vehicle that has ever been issued a “salvage” title or similar title under any state’s law; or has ever been declared a “total loss” or equivalent by a financial institution or insurer, such as by payment for a claim in lieu of repairs because the cost of repairs exceeded the cash value of the vehicle. This exclusion does not apply to the emission control warranties.

### **Incidental Damages**

Incidental or consequential damages associated with a vehicle failure. Such damages include but are not limited to inconvenience; the cost of transportation, telephone calls and lodging; the loss of personal or commercial property; and the loss of pay or revenue.

---

\*Lexus provides the first two scheduled maintenance services at no charge. See page 4 for details.

### Disclaimer of Extra Expenses and Damages

The performance of necessary repairs and adjustments is the exclusive remedy under this warranty or any implied warranty. Lexus does not authorize any person to create for it any other obligation or liability in connection with this vehicle. Lexus shall not be liable for incidental or consequential damages resulting from breach of this written warranty or any implied warranty.

Any implied warranty of merchantability or fitness for a particular purpose is limited to the duration of this written warranty, except in states where this limitation is not allowed.

## DISPUTE RESOLUTION

If a dispute arises regarding your warranty coverage, please follow the steps described on pages 9-10. Please note that you must use the National Center for Dispute Settlement before seeking remedies through a court action pursuant to the Magnuson-Moss Warranty Act. You may also be required to use the National Center for Dispute Settlement before seeking remedies under the Lemon Laws of your state. For the requirements applicable to your state, see the appropriate page of the *Lemon Law Guide* located in your vehicle.



## WHAT IS COVERED AND HOW LONG

### Emission Defect Warranty

Lexus warrants that your vehicle:

- Was designed, built and equipped to conform at the time of sale with applicable federal emissions standards.
- Is free from defects in materials and workmanship that may cause the vehicle to fail to meet these standards.

Federal regulations require that this warranty be in effect for two years or 24,000 miles from the vehicle's in-service date, whichever occurs first. However, under the terms of the Basic Warranty, Lexus provides coverage of four years or 50,000 miles, whichever occurs first. Specific components may have longer coverage under the terms of the Powertrain Warranty. Additionally, components marked "8/80" in the parts list on pages 23-24 have coverage of eight years or 80,000 miles, whichever occurs first.

### Emission Performance Warranty

Some states and localities have established vehicle inspection and maintenance (I/M) programs to encourage proper vehicle maintenance. If an EPA-approved I/M program is in force in your area, you are eligible for Emission Performance Warranty coverage.

Under the terms of the Emission Performance Warranty and federal regulations, Lexus will make all necessary repairs if both of the following occur:

- Your vehicle fails to meet applicable emissions standards as determined by an EPA-approved emissions test.
- This failure results or will result in some penalty to you – such as a fine or denial of the right to use your vehicle – under local, state or federal law.

This warranty is in effect for two years or 24,000 miles from the vehicle's in-service date, whichever occurs first. Additionally, components marked "8/80" in the parts list on pages 23-24 have coverage of eight years or 80,000 miles, whichever occurs first.

## WHAT IS NOT COVERED

These warranty obligations do not apply to failures or noncompliance caused by:

- The use of replacement parts not certified in accordance with aftermarket parts certification regulations.
- The use of replacement parts not equivalent in quality or design to original equipment parts.

Provisions under the “What Is Not Covered” section of the New Vehicle Limited Warranty also apply to this warranty.

## WARRANTY PARTS LIST

### Air/Fuel Metering System

- Air/fuel ratio feedback control system
- Cold-start enrichment system
- Deceleration control system
- Electronic fuel injection system components
  - Airflow sensor
  - Engine control module (8/80)
  - Throttle body
  - Other components

### Air Induction System

- Intake manifold and intake air surge tank

### Air Injection System

- Air injection manifold
- Air injection pump
- Airflow control valves

### Catalyst System

- Catalytic converter and protector (8/80)
- Constricted fuel filler neck
- Exhaust manifold
- Exhaust pipe (manifold to catalyst and/or catalyst to catalyst)

8/80 = Covered for eight years or 80,000 miles, whichever occurs first.

**Evaporative Control System**

- Charcoal canister
- Diaphragm valve
- Fuel filler cap
- Fuel tank
- Vapor liquid separator

**Exhaust Gas Recirculation (EGR) System**

- EGR gas temperature sensor
- EGR valve
- Associated parts

**Ignition System**

- Distributor and internal parts
- Ignition coil and ignitor
- Ignition wires
- Spark plugs\*

**Positive Crankcase Ventilation (PCV) System**

- Oil filler cap
- PCV valve or orifice

**Other Parts Used in Systems Listed**

- Data link connector (8/80)
- Hoses, clamps, fittings, tubing and mounting hardware
- Malfunction indicator light and bulb (8/80)
- Pulleys, belts and idlers
- Sealing gaskets and devices
- Sensors, solenoids, switches and valves

8/80 = Covered for eight years or 80,000 miles, whichever occurs first.

\*Warranted until first required maintenance under terms of the California Emission Control Warranty.

## MAINTENANCE

You are responsible for performance of the required maintenance indicated in the *Owner's Manual* and this guide. Lexus will not deny a warranty claim solely because you do not have records to show that you maintained your vehicle. However, any failure or noncompliance caused by lack of maintenance is not covered by this warranty.

**When maintenance and repairs are paid for by you, these services may be performed by you or by any automotive service provider you choose. Lexus will not deny a warranty claim solely because you used a service provider other than a Lexus dealership for maintenance and repairs.** However, any failure or noncompliance caused by improper maintenance or repairs is not covered by this warranty.

## REPLACEMENT PARTS

To ensure optimum performance and maintain the quality built into your vehicle's emission control systems, Lexus recommends the use of Genuine Lexus Parts when servicing or repairing the systems.

**Warranty coverage is not dependent upon the use of any particular brand of replacement parts and you may elect to use non-Genuine Lexus Parts for maintenance and repairs.** However, use of replacement parts that are not equivalent in quality to Genuine Lexus Parts may impair the effectiveness of the emission control systems.

If you use replacement parts that have maintenance or replacement schedules different from those of Genuine Lexus Parts, you must follow the maintenance and replacement schedules for the parts you are using. In addition, you should ensure that such parts are warranted by their manufacturers to be equivalent to Genuine Lexus Parts.

### IF YOUR VEHICLE FAILS AN EMISSIONS TEST

If your vehicle fails an EPA-approved emissions test, you may make a claim under the Emission Performance Warranty. To do so, take your vehicle to an authorized Lexus dealership and present a copy of the emissions test report. Also, take your maintenance records in case they are needed.

If your claim qualifies for coverage, the dealership will repair your vehicle within 30 days (unless a shorter period is required by law). If your claim is denied, Lexus will notify you in writing of the reason within the same period. If we fail to do so, we will repair your vehicle free of charge. The only exceptions allowed are when you request or agree to a delay, or when a delay is caused by factors beyond the control of Lexus or the dealership.

For information on how to obtain service under the Emission Defect Warranty, see page 37, "Obtaining Warranty Service."

### IF YOU HAVE QUESTIONS

If you have questions or concerns about your vehicle's federal emission warranty coverage, please follow the steps described on pages 9-10. In the case of the Emission Performance Warranty, you may also request information from or report complaints to:

U.S. Environmental Protection Agency  
Vehicle Programs & Compliance Division (6405J)  
Attn: Warranty Complaints  
401 M Street SW  
Washington, D.C. 20460

Vehicles equipped with a California Certified Emission Control System that are registered and operated in California or any state that adopts California emission warranty provisions are also covered by the California Emission Control Warranty (see page 28). Connecticut, Maine, Maryland, Massachusetts, New Jersey, New Mexico, Oregon, Pennsylvania, Rhode Island, Vermont and Washington are the other states to which the California Emission Control Warranty currently applies.

**DEALER CERTIFICATE**

We (the dealership) want you to know that at the time your new Lexus vehicle is being delivered:

- 1) On the basis of written notification furnished by Lexus, we have knowledge that the vehicle is covered by an EPA Certificate of Conformity.
- 2) We have visually inspected those emission control devices or portions thereof that are visible without removing or adjusting any components or systems, emissions-related or otherwise. On the basis of this inspection, there are no apparent deficiencies in the installation of emission control devices by Lexus. (For purposes of this certificate, "emission control devices" is limited to devices installed on a vehicle for the sole or primary purpose of controlling emissions and which were not in general use before 1968.)
- 3) We have performed all emission control system preparations required by Lexus prior to the sale of the vehicle as set forth in Lexus' current pre-delivery service manual.
- 4) Except as may be provided in Paragraph 5, if this vehicle fails an EPA-approved emissions test within three months or 4,000 miles (whichever comes first) of delivery to the ultimate purchaser, and the vehicle has been maintained and

used in accordance with the written instructions for proper maintenance and use, Lexus will remedy the nonconformity free of charge under the terms of the Emission Performance Warranty.

- 5) If vehicle was used as a company car or demonstrator, check box and complete the following:

The vehicle with which this statement is delivered was placed into service as a company car or demonstrator prior to delivery. The Emission Performance Warranty period commenced on the date the vehicle was first placed into service, which was

\_\_\_\_\_  
 Month                      Day                      Year

**Note:** The dealership makes no representation or warranty that the emission control system or any part thereof is without defect or that the system will perform properly. The Emission Performance Warranty referred to in Paragraph 4 and furnished with the vehicle is solely that of the manufacturer.

This statement is required by section 207 of the Clean Air Act (42 U.S.C. 7541) and the EPA regulations issued thereunder.

\_\_\_\_\_  
 Dealership name

**WARRANTY**

Vehicles equipped with a California Certified Emission Control System that are registered and operated in California or any state that adopts California emission warranty provisions are covered by this warranty. Connecticut, Maine, Maryland, Massachusetts, New Jersey, New Mexico, Oregon, Pennsylvania, Rhode Island, Vermont and Washington are the other states to which this warranty currently applies. Vehicles covered by this warranty are also covered by the Federal Emission Control Warranty (see page 22).

### YOUR WARRANTY RIGHTS AND OBLIGATIONS

The California Air Resources Board (CARB) and Lexus are pleased to explain the emission control system warranty for your 2011 vehicle. In California, new motor vehicles must be designed, built and equipped to meet the state's stringent anti-smog standards. CARB regulations require that Lexus must warrant the emission control system on your vehicle for the time periods indicated on the next page, provided there has been no abuse, neglect or improper maintenance of your vehicle.

Your emission control system may include parts such as the fuel injection system, ignition system, catalytic converter and engine computer. Also included may be hoses, belts, connectors and other emissions-related assemblies.

Where a warrantable condition exists, Lexus will repair your vehicle at no cost to you, including diagnosis, parts and labor.

## MANUFACTURER'S WARRANTY COVERAGE

- 1) For three years or 50,000 miles, whichever occurs first:
- If your vehicle fails a smog-check test, all necessary repairs and adjustments will be made by Lexus to ensure that your vehicle passes the test. This is your Emission Control System PERFORMANCE WARRANTY.
  - If an emissions-related part listed on pages 23–24 is defective, the part will be repaired or replaced by Lexus. This is your SHORT-TERM Emission Control System DEFECT WARRANTY.  
**Note:** Under the terms of the Basic Warranty, Lexus provides coverage of four years or 50,000 miles, whichever occurs first. Specific components may have longer coverage under the terms of the Powertrain Warranty.
- 2) For seven years or 70,000 miles, whichever occurs first:
- If an emissions-related part listed on page 30 is defective, the part will be repaired or replaced by Lexus. This is your LONG-TERM Emission Control System DEFECT WARRANTY.

## OWNER'S WARRANTY RESPONSIBILITIES

You are responsible for performance of the required maintenance indicated in the *Owner's Manual* and this guide. Lexus recommends that you retain all receipts covering maintenance on your vehicle, but Lexus cannot deny warranty coverage solely for the lack of receipts or your failure to ensure the performance of all scheduled maintenance.

You are responsible for presenting your vehicle to a Lexus dealership as soon as a problem exists. The warranty repairs should be completed in a reasonable amount of time, not to exceed 30 days.

You should also be aware that Lexus may deny you warranty coverage if your vehicle or a part has failed due to abuse, neglect, improper maintenance or unapproved modifications.

If you have any questions regarding your warranty rights and responsibilities, you should contact the Lexus Customer Satisfaction Department at (800) 255-3987 or the California Air Resources Board, Mobile Source Control Division, at 9528 Telstar Avenue, P.O. Box 8001, El Monte, CA 91734-8001.



## WHAT IS NOT COVERED

These warranty obligations do not apply to failures or noncompliance caused by:

- The use of replacement parts not certified in accordance with aftermarket parts certification regulations.
- The use of replacement parts not equivalent in quality or design to original equipment parts.

Provisions under the “What Is Not Covered” section of the New Vehicle Limited Warranty also apply to this warranty.

## PARTS LIST: LONG-TERM EMISSION DEFECT WARRANTY

The parts listed here are covered for seven years or 70,000 miles from the vehicle’s in-service date, whichever occurs first.

### Air/Fuel Metering System

- Engine control computer (engine control module)
- Throttle body

### Air Induction System

- Intake manifold and intake air surge tank

### Catalyst System

- Exhaust center pipe (including catalytic converter)
- Exhaust manifold (including manifold converter)

### Evaporative Control System

- Fuel tank

### Ignition System

- Knock sensor

### Other Parts Used in Above Systems

- Transmission solenoid
- Wire transmission (including temperature sensor)

## MAINTENANCE

You are responsible for performance of the required maintenance indicated in the *Owner's Manual* and this guide. Lexus will not deny a warranty claim solely because you do not have records to show that you maintained your vehicle. However, any failure or noncompliance caused by lack of maintenance is not covered by this warranty.

**When maintenance and repairs are paid for by you, these services may be performed by you or by any automotive service provider you choose. Lexus will not deny a warranty claim solely because you used a service provider other than a Lexus dealership for maintenance and repairs.** However, any failure or noncompliance caused by improper maintenance or repairs is not covered by this warranty.

## REPLACEMENT PARTS

To ensure optimum performance and maintain the quality built into your vehicle's emission control systems, Lexus recommends the use of Genuine Lexus Parts when servicing or repairing the systems.

**Warranty coverage is not dependent upon the use of any particular brand of replacement parts and you may elect to use non-Genuine Lexus Parts for maintenance and repairs.** However, use of replacement parts that are not equivalent in quality to Genuine Lexus Parts may impair the effectiveness of the emission control systems.

If you use replacement parts that have maintenance or replacement schedules different from those of Genuine Lexus Parts, you must follow the maintenance and replacement schedules for the parts you are using. In addition, you should ensure that such parts are warranted by their manufacturers to be equivalent to Genuine Lexus Parts.

### IF YOUR VEHICLE FAILS A SMOG-CHECK TEST

If your vehicle fails a smog-check test, you may make a claim under the Emission Performance Warranty. To do so, take your vehicle to an authorized Lexus dealership and present a copy of the smog-check test report. Also, take your maintenance records in case they are needed.

If your claim qualifies for coverage, the dealership will repair your vehicle within 30 days (unless a shorter period is required by law). If your claim is denied, Lexus will notify you in writing of the reason within the same period. If we fail to do so, we will repair your vehicle free of charge. The only exceptions allowed are when you request or agree to a delay, or when a delay is caused by factors beyond the control of Lexus or the dealership.

For information on how to obtain service under the Emission Defect Warranty, see page 37, "Obtaining Warranty Service."

### REPAIR DELAYS

If a Lexus dealership is unable to complete repairs on your vehicle within 30 days, you may have the repairs made under Lexus' provisions for emergency warranty repairs. See page 37 for details.

## IF YOU HAVE QUESTIONS

If you have questions or concerns about your vehicle's California emission warranty coverage, please follow the steps described on pages 9-10.

You may also request information from or report complaints to:

California Air Resources Board  
Mobile Source Control Division  
P.O. Box 8001  
El Monte, CA 91734-8001  
(800) 242-4450

### OBTAINING WARRANTY SERVICE

The tires that come as original equipment on your vehicle are warranted by their manufacturer and not Lexus. Please refer to the tire warranty statement included with the owner information in your vehicle.

To obtain warranty service for a tire, take the tire to an authorized dealer of the tire manufacturer. (Refer to your local phone directory for dealer locations.) Your Lexus dealer may also be able to assist you in obtaining warranty service from the manufacturer.

For additional warranty information or service assistance, contact the tire manufacturer directly.

### ORIGINAL EQUIPMENT TIRE MANUFACTURERS

#### **Bridgestone/Firestone**

535 Marriott Drive  
Nashville, TN 37214  
Bridgestone: (800) 847-3272  
Firestone: (800) 356-4644

#### **Dunlop Tires**

1144 East Market Street  
Akron, OH 44316  
(800) 321-2136

## GENERAL INFORMATION

You are responsible for ensuring that your Lexus is operated and maintained according to the instructions in the *Owner's Manual* and the "Maintenance Information" section of this guide.

You should keep detailed records of vehicle maintenance, since under some circumstances they may be required for warranty coverage. These records should include date of service, mileage at time of service and a description of service performed and/or parts installed. For your convenience, maintenance logs are included in the "Maintenance Information" section of this guide. If you sell your vehicle, you should give your maintenance records to the new owner.

Lexus will not deny a warranty claim solely because you do not have records to show that you maintained your vehicle. However, damage or failures caused by lack of proper maintenance are not covered under warranty.

## WHERE TO GO FOR MAINTENANCE

You may have maintenance performed on your vehicle by any qualified person or facility. However, Lexus recommends having maintenance performed by an authorized Lexus dealership.

Lexus dealership technicians are specially trained to maintain and repair Lexus vehicles. They stay current on the latest service information through Lexus technical bulletins, service publications and training courses. Many are also certified through the Lexus Commitment to Perfection Certification Program, which requires specialized, state-of-the-art training as well as rigorous exams through both Lexus and the National Institute for Automotive Service Excellence.

You can be confident you're getting the best possible service for your vehicle when you take it to a Lexus dealership. Plus, a Lexus dealership will always use Genuine Lexus Parts designed specifically for your vehicle.

## REPLACEMENT PARTS

Warranty coverage is not dependent upon the use of any particular brand of replacement parts. However, Lexus recommends using only Genuine Lexus Parts when you need to replace a part on your vehicle. Like all Lexus products, Genuine Lexus Parts are built to the highest standards of quality, durability and performance. They are also designed to fit your vehicle's exact specifications.

Your Lexus dealership maintains an extensive inventory of Genuine Lexus Parts to meet your vehicle service needs. And because it is linked electronically to Lexus Parts Distribution Centers, the dealership has quick access to any parts it may not have in stock.

Genuine Lexus Parts are covered by their own warranty (see your dealer for details) or the remainder of any applicable New Vehicle Limited Warranty, whichever is longer. **Non-Genuine Lexus Parts, or any damage or failures resulting from their use, are not covered by any Lexus warranty.**

## BY GEOGRAPHIC REGION

### In the United States, U.S. Territories and Canada

To obtain warranty service in the United States, U.S. territories or Canada, take your vehicle to an authorized Lexus dealership. If your vehicle cannot be driven, contact your nearest Lexus dealership for towing assistance. You do not have to pay for towing to the nearest Lexus dealership if your vehicle is inoperable due to failure of a warranted part.

### Outside the United States, U.S. Territories and Canada

If you are using your vehicle outside the United States, U.S. territories and Canada and need warranty service, contact a local Lexus dealership. Please note, however, that your vehicle may not be repaired free of charge because the local Lexus distributor may have no obligation to provide warranty service for your vehicle, and/or your vehicle may not comply with local regulatory or environmental requirements.

## EMERGENCY REPAIRS

Lexus recommends having maintenance and repairs for your vehicle performed by an authorized Lexus dealership. To locate your nearest authorized Lexus dealership, log on to [www.lexus.com](http://www.lexus.com) or contact Lexus Customer Satisfaction at (800)255-3987.

Maintenance and repairs not performed by an authorized Lexus dealership should be performed by a qualified technician following procedures in Lexus service and repair publications.

If your vehicle is inoperable or unsafe to drive and there is no Lexus dealership reasonably available to make repairs, you may perform the repairs yourself or have them performed by another automotive service provider. Lexus will reimburse you for any of the repairs that are covered by warranty. To receive reimbursement, present to an authorized Lexus dealership your paid repair invoices and any parts that were removed from the vehicle. You will be reimbursed for



warranted parts at the manufacturer's suggested retail price and warranted labor at a geographically appropriate hourly rate multiplied by Lexus' recommended time allowance for the repair.

If your vehicle requires emergency repair, Lexus assumes no liability for subsequent failures caused by improper repairs or the use of non-Genuine Lexus Parts unless you have the vehicle properly repaired in a timely manner. To ensure that warranty coverage remains intact, have your vehicle inspected by an authorized Lexus dealership as soon as possible after an emergency repair.

Regular maintenance is essential to obtaining the highest level of performance, safety and reliability from your Lexus. It can also enhance your vehicle's resale value. This section of the *Warranty and Services Guide* is designed to help you make sure your vehicle receives proper and timely maintenance. It includes factory-recommended maintenance guidelines as well as logs in which to document your vehicle's maintenance history.

In addition to scheduled maintenance, your Lexus requires ongoing general maintenance such as fluid checks and visual inspections. These procedures are listed on pages 42-43 of this booklet and described in detail in

the "Maintenance" section of the *Owner's Manual*.

**It is especially important to check your vehicle's engine oil once a month and to regularly replace the engine oil and oil filter. Failure to do so can cause oil starvation and/or oil gelling, which can result in severe damage to your vehicle and require costly repairs that are not covered by the New Vehicle Limited Warranty.**

With proper maintenance and care, your vehicle will last longer and deliver more dependable, economical performance. Follow this booklet's recommendations and you'll enjoy maximum reliability and peace of mind from your Lexus for many years to come.



Maintaining your vehicle according to the recommendations in this booklet is required to ensure that your warranty coverage remains intact. You should keep detailed records of vehicle maintenance, including date of service, mileage at time of service and a description of service and/or parts installation performed. The maintenance logs in this booklet are a good place to record this information. If you sell your vehicle, be sure to give your maintenance records to the new owner.

Lexus will not deny a warranty claim solely because you do not have records to show that you maintained your vehicle. However, damage or failures caused by lack of proper maintenance are not covered under warranty.

Maintenance and repair services may be performed by you or by any automotive service provider you choose. Lexus will not deny a warranty claim solely because you used a service

provider other than a Lexus dealership for maintenance and repairs. However, damage or failures caused by improper maintenance or repairs are not covered under warranty.

Your dealer may recommend more frequent maintenance intervals or more maintenance services than those listed in the scheduled maintenance log. These additional services are not required to maintain your warranty coverage. Ask your dealer for an explanation of any recommended maintenance not included in the scheduled maintenance log.

For a complete description of Lexus warranty coverages, see pages 16–33 of this booklet.

To ensure that your vehicle receives first-quality service and factory-authorized parts, Lexus recommends having maintenance performed by an authorized Lexus dealership. To locate your nearest authorized Lexus dealership, log on to [www.lexus.com](http://www.lexus.com) or contact Lexus Customer Satisfaction at (800) 255-3987.

Lexus dealership technicians are experts in the maintenance and repair of Lexus vehicles. They stay current on the latest service information through Lexus technical bulletins, service publications and training courses. Many are also certified through the Lexus Commitment to Perfection Certification Program, which requires specialized, state-of-the-art training as well as rigorous exams through both Lexus and the National Institute for Automotive Service Excellence.

Additionally, when you have your vehicle serviced at a Lexus dealership, your service information is recorded in the Lexus National Service History database. This is the first database of its kind in the automotive industry. It can be accessed by

any Lexus dealership in the U.S. – a great convenience if you relocate or need to have your vehicle serviced while traveling.

You can be confident you're getting the best possible service for your vehicle when you take it to a Lexus dealership. Don't trust your investment to anything less than a team of Lexus specialists.

Maintenance and repairs not performed by an authorized Lexus dealership should be performed by a qualified technician following procedures in Lexus service and repair publications.

In addition to scheduled maintenance, your Lexus requires ongoing general maintenance such as fluid checks and visual inspections. The recommended guidelines for inspections are listed below. Please refer to the “Maintenance” section of the *Owner’s Manual* for a detailed description of inspection procedures.

### Every 30 Days

At least once every 30 days, perform these inspections:

- Check engine oil level using the dipstick
- Visually check engine coolant level on the see-through reservoir
- Visually check brake fluid level on the see-through reservoir
- Visually check condition of battery
- Check level of windshield washer fluid
- Check tire pressure
- Check tires for damage and wear
- Check installation of driver’s floor mat

### After a Car Wash

- Check installation of driver’s floor mat

### After Off-Road Driving

Whenever you drive off-road through deep sand, mud or water, perform these inspections daily:

- Check axle shaft boots
- Check ball joints and dust covers
- Check brake lines and hoses
- Check brake pads/rotors and parking brake linings/drums
- Check differential oil
- Check engine air filter
- Check nuts and bolts on chassis
- Check steering linkage and boots
- Check transfer case oil (AWD models)
- Check transmission fluid

### When Cleaning the Interior

- Remove dirt and dust with a vacuum cleaner. Wipe dirty surfaces with a soft cloth dampened with warm water.
- When cleaning carpet or cloth interior, remove dirt and dust with a vacuum cleaner. Apply a foaming-type carpet cleaner with a sponge or brush, allowing cleaner to work for a few minutes to loosen dirt. Continue by rubbing carpet or cloth interior in a circular motion. Wipe off any excess cleaner with a clean cloth. If any dirt remains, repeat process. Best results are obtained by keeping carpet and cloth interior as dry as possible.
- When cleaning leather interior, remove dirt and dust with a vacuum cleaner. Using a sponge, apply a small amount of neutral wool detergent mixed in water, rubbing in a circular motion. Wipe off any excess detergent and let leather dry in an open-air location.

### When Cleaning the Exterior

- Working from top to bottom, apply lots of low-pressure water to the body, wheel wells and underside of vehicle to remove dirt and dust. Wash the vehicle body using a soft sponge or cotton cloth with mild car-wash soap. Rinse off with water.
- If water does not bead on a clean vehicle surface, apply car wax using a soft cotton cloth when the body of the vehicle is cool.

### When Cleaning the Wheels

- Wait for hot wheels to cool before getting wheels wet.
- Using a soft sponge or cotton cloth, apply same mild car-wash soap as used for the vehicle body. Quickly rinse off with water. Using a soft cotton cloth, apply same car wax as used for the vehicle body.

## Determining Your Maintenance Interval: Months vs. Mileage

Lexus recommends obtaining scheduled maintenance for your vehicle every six months or 5,000 miles, whichever occurs first.

For example:

- If at six months you have driven less than 5,000 miles, you should obtain maintenance at **six months**; don't wait until 5,000 miles.
- If you drive 5,000 miles in less than six months, you should obtain maintenance at **5,000 miles**; don't wait until six months.

Be sure to keep an eye on your mileage so that you obtain maintenance when recommended. If you are a low-mileage driver, mark your calendar to remind yourself to obtain maintenance every six months.

## Special Operating Conditions

In addition to standard maintenance items, vehicles that are driven under special operating conditions require further maintenance service. These special operating conditions, which put added demands on a vehicle, include:

- Driving on dirt roads or on dusty roads
- Repeated trips of less than five miles in temperatures below 32° F or 0° C
- Extensive idling and/or low-speed driving for long distances, such as police, taxi or door-to-door delivery use

**If you drive primarily under any of the conditions noted, you should replace the engine oil and oil filter every six months or 5,000 miles.** Some of these special operating conditions require other maintenance items; these items are indicated in each maintenance chart.

If you drive only occasionally under any of the special operating conditions noted, it is not necessary to change the oil every six months or 5,000 miles or to perform the additional services listed in the charts. This added maintenance is required only if you drive primarily under any of the special operating conditions.

### **Complimentary First Scheduled Maintenance Service: Six Months or 5,000 Miles**

Lexus provides your first scheduled maintenance service at no charge. The service is performed at six months or 5,000 miles, whichever occurs first. To obtain this service, contact your Lexus dealership. Your complimentary service will include these items:

- Inspect and adjust all fluid levels
- Program Lexus Personalized Settings, if requested
- Reset maintenance reminder light
- Rotate tires

- Visually inspect brake pads, calipers and rotors
- Check installation of driver's floor mat
- Road-test vehicle

### **What are Lexus Personalized Settings?**

Your vehicle includes a variety of electronic features that can be programmed to your preferences. For example, doors can be programmed to remain locked when you shift into "Park." (For more information, see the "Customizable Features" section of the Specifications chapter in your *Owner's Manual*.) Programming of these features is performed once at no charge, provided you obtain the service at the six-month/5,000-mile scheduled maintenance service. Programming of your Lexus Personalized Settings requires special equipment and may be performed only by an authorized Lexus dealership.



### **Complimentary Second Scheduled Maintenance Service: 12 Months or 10,000 Miles**

Lexus also provides your second scheduled maintenance service at no charge. The service is performed at 12 months or 10,000 miles, whichever occurs first. To obtain this service, contact your Lexus dealership. Your complimentary service will include these items:

- Replace engine oil with 0W-20 oil; replace oil filter
- Reset maintenance reminder light
- Rotate tires
- Visually inspect brake pads, calipers and rotors
- Check installation of driver's floor mat
- Road-test vehicle

If you do the majority of your driving under certain special operating conditions, additional items are included in this service. See the "12 Months or 10,000 Miles" chart on page 48.



# SCHEDULED MAINTENANCE LOG

## 6 Months or 5,000 Miles<sup>1</sup>

- Inspect and adjust all fluid levels
- Program Lexus Personalized Settings, if requested
- Reset maintenance reminder light
- Rotate tires
- Visually inspect brake pads, calipers and rotors
- Check installation of driver's floor mat
- Road-test vehicle

**Note:** If you drive primarily under certain special operating conditions, you should also replace the engine oil with OW-20 oil and replace the oil filter. See page 44 for conditions that apply. Some conditions require additional maintenance. See below.

**If you drive primarily under either of these special operating conditions, perform these additional items:**

### Driving off-road, on dirt roads or on dusty roads:

- Inspect axle shaft boots
- Inspect ball joints and dust covers
- Inspect engine air filter
- Inspect steering linkage and boots
- Re-torque nuts and bolts of drive shaft (AWD)
- Tighten nuts and bolts on chassis

### Towing a trailer, using a car-top carrier or heavy vehicle loading:

- Re-torque nuts and bolts of drive shaft (AWD)
- Tighten nuts and bolts on chassis

Date: \_\_\_\_\_ Mileage: \_\_\_\_\_

## 12 Months or 10,000 Miles<sup>2</sup>

- Replace engine oil with OW-20 oil; replace oil filter
- Reset maintenance reminder light
- Rotate tires
- Visually inspect brake pads, calipers and rotors
- Check installation of driver's floor mat
- Road-test vehicle

**If you drive primarily under either of these special operating conditions, perform these additional items:**

### Driving off-road, on dirt roads or on dusty roads:

- Inspect axle shaft boots
- Inspect ball joints and dust covers
- Inspect engine air filter
- Inspect steering linkage and boots
- Re-torque nuts and bolts of drive shaft (AWD)
- Tighten nuts and bolts on chassis

### Towing a trailer, using a car-top carrier or heavy vehicle loading:

- Re-torque nuts and bolts of drive shaft (AWD)
- Tighten nuts and bolts on chassis

Date: \_\_\_\_\_ Mileage: \_\_\_\_\_

<sup>1</sup>This service, excluding maintenance required for special operating conditions, is complimentary when performed by an authorized Lexus dealership.

<sup>2</sup>This service is complimentary when performed by an authorized Lexus dealership.

## 18 Months or 15,000 Miles

- Clean air conditioner filter
- Inspect and adjust all fluid levels
- Replace Smart Key battery
- Reset maintenance reminder light
- Re-torque nuts and bolts of drive shaft (AWD)
- Rotate tires
- Visually inspect brake pads, calipers and rotors
- Check installation of driver's floor mat
- Road-test vehicle
- Inspect the following:
 

<input type="checkbox"/> Axle shaft boots	<input type="checkbox"/> Rack and pinion assembly
<input type="checkbox"/> Ball joints and dust covers	<input type="checkbox"/> Rear differential oil (AWD)
<input type="checkbox"/> Body	<input type="checkbox"/> Steering linkage and boots
<input type="checkbox"/> Brake lines and hoses	<input type="checkbox"/> Transfer case oil (AWD)
<input type="checkbox"/> Engine coolant (see page 70)	
<input type="checkbox"/> Exhaust pipes and mountings	

**Note:** If 0W-20 oil was not used at last oil change, or if you drive primarily under certain special operating conditions, you should also replace the engine oil with 0W-20 oil and replace the oil filter. See page 44 for conditions that apply. Some conditions require additional maintenance. See below.

**If you drive primarily under either of these special operating conditions, perform these additional items:**

**Driving off-road, on dirt roads or on dusty roads:**

- Inspect engine air filter
- Tighten nuts and bolts on chassis

**Towing a trailer, using a car-top carrier or heavy vehicle loading:**

- Replace rear differential oil (AWD)
- Replace transfer case oil (AWD)
- Tighten nuts and bolts on chassis

Date: \_\_\_\_\_ Mileage: \_\_\_\_\_

# SCHEDULED MAINTENANCE LOG

## 24 Months or 20,000 Miles

- Replace engine oil with OW-20 oil; replace oil filter
- Reset maintenance reminder light
- Rotate tires
- Visually inspect brake pads, calipers and rotors
- Check installation of driver's floor mat
- Road-test vehicle

**If you drive primarily under either of these special operating conditions, perform these additional items:**

### **Driving off-road, on dirt roads or on dusty roads:**

- Inspect axle shaft boots
- Inspect ball joints and dust covers
- Inspect engine air filter
- Inspect steering linkage and boots
- Re-torque nuts and bolts of drive shaft (AWD)
- Tighten nuts and bolts on chassis

### **Towing a trailer, using a car-top carrier or heavy vehicle loading:**

- Re-torque nuts and bolts of drive shaft (AWD)
- Tighten nuts and bolts on chassis

Date: \_\_\_\_\_ Mileage: \_\_\_\_\_

## 30 Months or 25,000 Miles

- Inspect and adjust all fluid levels
- Reset maintenance reminder light
- Rotate tires
- Visually inspect brake pads, calipers and rotors
- Check installation of driver's floor mat
- Road-test vehicle

**Note:** If OW-20 oil was not used at last oil change, or if you drive primarily under certain special operating conditions, you should also replace the engine oil with OW-20 oil and replace the oil filter. See page 44 for conditions that apply. Some conditions require additional maintenance. See below.

**If you drive primarily under either of these special operating conditions, perform these additional items:**

### **Driving off-road, on dirt roads or on dusty roads:**

- Inspect axle shaft boots
- Inspect ball joints and dust covers
- Inspect engine air filter
- Inspect steering linkage and boots
- Re-torque nuts and bolts of drive shaft (AWD)
- Tighten nuts and bolts on chassis

### **Towing a trailer, using a car-top carrier or heavy vehicle loading:**

- Re-torque nuts and bolts of drive shaft (AWD)
- Tighten nuts and bolts on chassis

Date: \_\_\_\_\_ Mileage: \_\_\_\_\_

## 36 Months or 30,000 Miles

- |   |   |
|---|---|
| <ul style="list-style-type: none"> <li><input type="checkbox"/> Replace engine oil with OW-20 oil; replace oil filter</li> <li><input type="checkbox"/> Reset maintenance reminder light</li> <li><input type="checkbox"/> Rotate tires</li> <li><input type="checkbox"/> Re-torque nuts and bolts of drive shaft (AWD)</li> <li><input type="checkbox"/> Replace air conditioner filter</li> <li><input type="checkbox"/> Replace brake fluid</li> <li><input type="checkbox"/> Replace engine air filter</li> <li><input type="checkbox"/> Inspect the following:             <ul style="list-style-type: none"> <li>___ Axle shaft boots</li> <li>___ Ball joints and dust covers</li> <li>___ Body</li> <li>___ Brake lines and hoses</li> <li>___ Brake rotor thickness and runout</li> <li>___ Engine coolant (see page 70)</li> <li>___ Exhaust pipes and mountings</li> <li>___ Fuel lines and connections, fuel tank band and fuel tank vapor vent system hoses</li> </ul> </li> </ul> | <ul style="list-style-type: none"> <li><input type="checkbox"/> Replace Smart Key battery</li> <li><input type="checkbox"/> Visually inspect brake pads, calipers and rotors</li> <li><input type="checkbox"/> Check installation of driver's floor mat</li> <li><input type="checkbox"/> Road-test vehicle</li> <li>___ Fuel tank cap gasket</li> <li>___ Rack and pinion assembly</li> <li>___ Rear differential oil (AWD)</li> <li>___ Steering linkage and boots</li> <li>___ Transfer case oil (AWD)</li> <li>___ Transmission for signs of leakage</li> </ul> |
|---|---|

**If you drive primarily under either of these special operating conditions, perform these additional items:**

**Driving off-road, on dirt roads or on dusty roads:**

- Tighten nuts and bolts on chassis

**Towing a trailer, using a car-top carrier or heavy vehicle loading:**

- Replace rear differential oil (AWD)
- Replace transfer case oil (AWD)
- Tighten nuts and bolts on chassis

Date: \_\_\_\_\_ Mileage: \_\_\_\_\_

## 42 Months or 35,000 Miles

- Inspect and adjust all fluid levels
- Reset maintenance reminder light
- Rotate tires
- Visually inspect brake pads, calipers and rotors
- Check installation of driver's floor mat
- Road-test vehicle

**Note:** If OW-20 oil was not used at last oil change, or if you drive primarily under certain special operating conditions, you should also replace the engine oil with OW-20 oil and replace the oil filter. See page 44 for conditions that apply. Some conditions require additional maintenance. See below.

**If you drive primarily under either of these special operating conditions, perform these additional items:**

### Driving off-road, on dirt roads or on dusty roads:

- Inspect axle shaft boots
- Inspect ball joints and dust covers
- Inspect engine air filter
- Inspect steering linkage and boots
- Re-torque nuts and bolts of drive shaft (AWD)
- Tighten nuts and bolts on chassis

### Towing a trailer, using a car-top carrier or heavy vehicle loading:

- Re-torque nuts and bolts of drive shaft (AWD)
- Tighten nuts and bolts on chassis

Date: \_\_\_\_\_ Mileage: \_\_\_\_\_

## 48 Months or 40,000 Miles

- Replace engine oil with OW-20 oil; replace oil filter
- Reset maintenance reminder light
- Rotate tires
- Visually inspect brake pads, calipers and rotors
- Check installation of driver's floor mat
- Road-test vehicle

**If you drive primarily under either of these special operating conditions, perform these additional items:**

### Driving off-road, on dirt roads or on dusty roads:

- Inspect axle shaft boots
- Inspect ball joints and dust covers
- Inspect engine air filter
- Inspect steering linkage and boots
- Re-torque nuts and bolts of drive shaft (AWD)
- Tighten nuts and bolts on chassis

### Towing a trailer, using a car-top carrier or heavy vehicle loading:

- Re-torque nuts and bolts of drive shaft (AWD)
- Tighten nuts and bolts on chassis

Date: \_\_\_\_\_ Mileage: \_\_\_\_\_

## 54 Months or 45,000 Miles

- Clean air conditioner filter
- Inspect and adjust all fluid levels
- Replace Smart Key battery
- Reset maintenance reminder light
- Re-torque nuts and bolts of drive shaft (AWD)
- Rotate tires
- Visually inspect brake pads, calipers and rotors
- Check installation of driver's floor mat
- Road-test vehicle
- Inspect the following:
 

<input type="checkbox"/> Axle shaft boots	<input type="checkbox"/> Rack and pinion assembly
<input type="checkbox"/> Ball joints and dust covers	<input type="checkbox"/> Rear differential oil (AWD)
<input type="checkbox"/> Body	<input type="checkbox"/> Steering linkage and boots
<input type="checkbox"/> Brake lines and hoses	<input type="checkbox"/> Transfer case oil (AWD)
<input type="checkbox"/> Engine coolant (see page 70)	
<input type="checkbox"/> Exhaust pipes and mountings	

**Note:** If OW-20 oil was not used at last oil change, or if you drive primarily under certain special operating conditions, you should also replace the engine oil with OW-20 oil and replace the oil filter. See page 44 for conditions that apply. Some conditions require additional maintenance. See below.

**If you drive primarily under either of these special operating conditions, perform these additional items:**

**Driving off-road, on dirt roads or on dusty roads:**

- Inspect engine air filter
- Tighten nuts and bolts on chassis

**Towing a trailer, using a car-top carrier or heavy vehicle loading:**

- Replace rear differential oil (AWD)
- Replace transfer case oil (AWD)
- Tighten nuts and bolts on chassis

Date: \_\_\_\_\_ Mileage: \_\_\_\_\_



## 60 Months or 50,000 Miles

- Replace engine oil with OW-20 oil; replace oil filter
- Reset maintenance reminder light
- Rotate tires
- Visually inspect brake pads, calipers and rotors
- Check installation of driver's floor mat
- Road-test vehicle

**If you drive primarily under either of these special operating conditions, perform these additional items:**

### Driving off-road, on dirt roads or on dusty roads:

- Inspect axle shaft boots
- Inspect ball joints and dust covers
- Inspect engine air filter
- Inspect steering linkage and boots
- Re-torque nuts and bolts of drive shaft (AWD)
- Tighten nuts and bolts on chassis

### Towing a trailer, using a car-top carrier or heavy vehicle loading:

- Re-torque nuts and bolts of drive shaft (AWD)
- Tighten nuts and bolts on chassis

Date: \_\_\_\_\_ Mileage: \_\_\_\_\_

## 66 Months or 55,000 Miles

- Inspect and adjust all fluid levels
- Reset maintenance reminder light
- Rotate tires
- Visually inspect brake pads, calipers and rotors
- Check installation of driver's floor mat
- Road-test vehicle

**Note:** If OW-20 oil was not used at last oil change, or if you drive primarily under certain special operating conditions, you should also replace the engine oil with OW-20 oil and replace the oil filter. See page 44 for conditions that apply. Some conditions require additional maintenance. See below.

**If you drive primarily under either of these special operating conditions, perform these additional items:**

### Driving off-road, on dirt roads or on dusty roads:

- Inspect axle shaft boots
- Inspect ball joints and dust covers
- Inspect engine air filter
- Inspect steering linkage and boots
- Re-torque nuts and bolts of drive shaft (AWD)
- Tighten nuts and bolts on chassis

### Towing a trailer, using a car-top carrier or heavy vehicle loading:

- Re-torque nuts and bolts of drive shaft (AWD)
- Tighten nuts and bolts on chassis

Date: \_\_\_\_\_ Mileage: \_\_\_\_\_

## 72 Months or 60,000 Miles

- |  |  |
|--|--|
| <ul style="list-style-type: none"> <li><input type="checkbox"/> Replace engine oil with OW-20 oil; replace oil filter</li> <li><input type="checkbox"/> Re-torque nuts and bolts of drive shaft (AWD)</li> <li><input type="checkbox"/> Replace air conditioner filter</li> <li><input type="checkbox"/> Replace brake fluid</li> <li><input type="checkbox"/> Replace engine air filter</li> <li><input type="checkbox"/> Replace Smart Key battery</li> <li><input type="checkbox"/> Reset maintenance reminder light</li> <li><input type="checkbox"/> Inspect the following:             <ul style="list-style-type: none"> <li>___ Axle shaft boots</li> <li>___ Ball joints and dust covers</li> <li>___ Body</li> <li>___ Brake lines and hoses</li> <li>___ Brake rotor thickness and runout</li> <li>___ Drive belt</li> <li>___ Engine coolant (see page 70)</li> <li>___ Exhaust pipes and mountings</li> <li>___ Fuel lines and connections, fuel tank band and fuel tank vapor vent system hoses</li> </ul> </li> </ul> | <ul style="list-style-type: none"> <li><input type="checkbox"/> Rotate tires</li> <li><input type="checkbox"/> Visually inspect brake pads, calipers and rotors</li> <li><input type="checkbox"/> Check installation of driver's floor mat</li> <li><input type="checkbox"/> Road-test vehicle</li> <li>___ Fuel tank cap gasket</li> <li>___ Rack and pinion assembly</li> <li>___ Rear differential oil (AWD)</li> <li>___ Steering linkage and boots</li> <li>___ Transfer case oil (AWD)</li> <li>___ Transmission for signs of leakage</li> </ul> |
|--|--|

**If you drive primarily under either of these special operating conditions, perform these additional items:**

**Driving off-road, on dirt roads or on dusty roads:**

- Tighten nuts and bolts on chassis

**Towing a trailer, using a car-top carrier or heavy vehicle loading:**

- Replace rear differential oil (AWD)
- Replace transfer case oil (AWD)
- Replace transmission fluid
- Tighten nuts and bolts on chassis

Date: \_\_\_\_\_ Mileage: \_\_\_\_\_

# SCHEDULED MAINTENANCE LOG

## 78 Months or 65,000 Miles

- Inspect and adjust all fluid levels
- Reset maintenance reminder light
- Rotate tires
- Visually inspect brake pads, calipers and rotors
- Check installation of driver's floor mat
- Road-test vehicle

**Note:** If OW-20 oil was not used at last oil change, or if you drive primarily under certain special operating conditions, you should also replace the engine oil with OW-20 oil and replace the oil filter. See page 44 for conditions that apply. Some conditions require additional maintenance. See below.

**If you drive primarily under either of these special operating conditions, perform these additional items:**

### Driving off-road, on dirt roads or on dusty roads:

- Inspect axle shaft boots
- Inspect ball joints and dust covers
- Inspect engine air filter
- Inspect steering linkage and boots
- Re-torque nuts and bolts of drive shaft (AWD)
- Tighten nuts and bolts on chassis

### Towing a trailer, using a car-top carrier or heavy vehicle loading:

- Re-torque nuts and bolts of drive shaft (AWD)
- Tighten nuts and bolts on chassis

Date: \_\_\_\_\_ Mileage: \_\_\_\_\_

## 84 Months or 70,000 Miles

- Replace engine oil with OW-20 oil; replace oil filter
- Reset maintenance reminder light
- Rotate tires
- Visually inspect brake pads, calipers and rotors
- Check installation of driver's floor mat
- Road-test vehicle

**If you drive primarily under either of these special operating conditions, perform these additional items:**

### Driving off-road, on dirt roads or on dusty roads:

- Inspect axle shaft boots
- Inspect ball joints and dust covers
- Inspect engine air filter
- Inspect steering linkage and boots
- Re-torque nuts and bolts of drive shaft (AWD)
- Tighten nuts and bolts on chassis

### Towing a trailer, using a car-top carrier or heavy vehicle loading:

- Re-torque nuts and bolts of drive shaft (AWD)
- Tighten nuts and bolts on chassis

Date: \_\_\_\_\_ Mileage: \_\_\_\_\_

## 90 Months or 75,000 Miles

- Clean air conditioner filter
- Inspect and adjust all fluid levels
- Re-torque nuts and bolts of drive shaft (AWD)
- Replace Smart Key battery
- Reset maintenance reminder light
- Rotate tires
- Visually inspect brake pads, calipers and rotors
- Check installation of driver's floor mat
- Road-test vehicle
- Inspect the following:
 

<ul style="list-style-type: none"> <li>___ Axle shaft boots</li> <li>___ Ball joints and dust covers</li> <li>___ Body</li> <li>___ Brake lines and hoses</li> <li>___ Drive belt</li> <li>___ Engine coolant (see page 70)</li> </ul>	<ul style="list-style-type: none"> <li>___ Exhaust pipes and mountings</li> <li>___ Rack and pinion assembly</li> <li>___ Rear differential oil (AWD)</li> <li>___ Steering linkage and boots</li> <li>___ Transfer case oil (AWD)</li> </ul>
--	---

**Note:** If OW-20 oil was not used at last oil change, or if you drive primarily under certain special operating conditions, you should also replace the engine oil with OW-20 oil and replace the oil filter. See page 44 for conditions that apply. Some conditions require additional maintenance. See below.

**If you drive primarily under either of these special operating conditions, perform these additional items:**

**Driving off-road, on dirt roads or on dusty roads:**

- Inspect engine air filter
- Tighten nuts and bolts on chassis

**Towing a trailer, using a car-top carrier or heavy vehicle loading:**

- Replace rear differential oil (AWD)
- Replace transfer case oil (AWD)
- Tighten nuts and bolts on chassis

Date: \_\_\_\_\_ Mileage: \_\_\_\_\_

## 96 Months or 80,000 Miles

- Replace engine oil with OW-20 oil; replace oil filter
- Reset maintenance reminder light
- Rotate tires
- Visually inspect brake pads, calipers and rotors
- Check installation of driver's floor mat
- Road-test vehicle

**If you drive primarily under either of these special operating conditions, perform these additional items:**

### Driving off-road, on dirt roads or on dusty roads:

- Inspect axle shaft boots
- Inspect ball joints and dust covers
- Inspect engine air filter
- Inspect steering linkage and boots
- Re-torque nuts and bolts of drive shaft (AWD)
- Tighten nuts and bolts on chassis

### Towing a trailer, using a car-top carrier or heavy vehicle loading:

- Re-torque nuts and bolts of drive shaft (AWD)
- Tighten nuts and bolts on chassis

Date: \_\_\_\_\_ Mileage: \_\_\_\_\_

## 102 Months or 85,000 Miles

- Inspect and adjust all fluid levels
- Reset maintenance reminder light
- Rotate tires
- Visually inspect brake pads, calipers and rotors
- Check installation of driver's floor mat
- Road-test vehicle

**Note:** If OW-20 oil was not used at last oil change, or if you drive primarily under certain special operating conditions, you should also replace the engine oil with OW-20 oil and replace the oil filter. See page 44 for conditions that apply. Some conditions require additional maintenance. See below.

**If you drive primarily under either of these special operating conditions, perform these additional items:**

### Driving off-road, on dirt roads or on dusty roads:

- Inspect axle shaft boots
- Inspect ball joints and dust covers
- Inspect engine air filter
- Inspect steering linkage and boots
- Re-torque nuts and bolts of drive shaft (AWD)
- Tighten nuts and bolts on chassis

### Towing a trailer, using a car-top carrier or heavy vehicle loading:

- Re-torque nuts and bolts of drive shaft (AWD)
- Tighten nuts and bolts on chassis

Date: \_\_\_\_\_ Mileage: \_\_\_\_\_

## SCHEDULED MAINTENANCE LOG

### 108 Months or 90,000 Miles

- |  |  |
|--|--|
| <ul style="list-style-type: none"> <li><input type="checkbox"/> Replace engine oil with OW-20 oil; replace oil filter</li> <li><input type="checkbox"/> Re-torque nuts and bolts of drive shaft (AWD)</li> <li><input type="checkbox"/> Replace air conditioner filter</li> <li><input type="checkbox"/> Replace brake fluid</li> <li><input type="checkbox"/> Replace engine air filter</li> <li><input type="checkbox"/> Replace Smart Key battery</li> <li><input type="checkbox"/> Reset maintenance reminder light</li> <li><input type="checkbox"/> Inspect the following:             <ul style="list-style-type: none"> <li>___ Axle shaft boots</li> <li>___ Ball joints and dust covers</li> <li>___ Body</li> <li>___ Brake lines and hoses</li> <li>___ Brake rotor thickness and runout</li> <li>___ Drive belt</li> <li>___ Engine coolant (see page 70)</li> <li>___ Exhaust pipes and mountings</li> <li>___ Fuel lines and connections, fuel tank band and fuel tank vapor vent system hoses</li> </ul> </li> </ul> | <ul style="list-style-type: none"> <li><input type="checkbox"/> Rotate tires</li> <li><input type="checkbox"/> Visually inspect brake pads, calipers and rotors</li> <li><input type="checkbox"/> Check installation of driver's floor mat</li> <li><input type="checkbox"/> Road-test vehicle</li> <li>___ Fuel tank cap gasket</li> <li>___ Rack and pinion assembly</li> <li>___ Rear differential oil (AWD)</li> <li>___ Steering linkage and boots</li> <li>___ Transfer case oil (AWD)</li> <li>___ Transmission for signs of leakage</li> </ul> |
|--|--|

**If you drive primarily under either of these special operating conditions, perform these additional items:**

**Driving off-road, on dirt roads or on dusty roads:**

- Tighten nuts and bolts on chassis

**Towing a trailer, using a car-top carrier or heavy vehicle loading:**

- Replace rear differential oil (AWD)
- Replace transfer case oil (AWD)
- Tighten nuts and bolts on chassis

Date: \_\_\_\_\_ Mileage: \_\_\_\_\_

# SCHEDULED MAINTENANCE LOG

## 114 Months or 95,000 Miles

- Inspect and adjust all fluid levels
- Reset maintenance reminder light
- Rotate tires
- Visually inspect brake pads, calipers and rotors
- Check installation of driver's floor mat
- Road-test vehicle

**Note:** If OW-20 oil was not used at last oil change, or if you drive primarily under certain special operating conditions, you should also replace the engine oil with OW-20 oil and replace the oil filter. See page 44 for conditions that apply. Some conditions require additional maintenance. See below.

**If you drive primarily under either of these special operating conditions, perform these additional items:**

### Driving off-road, on dirt roads or on dusty roads:

- Inspect axle shaft boots
- Inspect ball joints and dust covers
- Inspect engine air filter
- Inspect steering linkage and boots
- Re-torque nuts and bolts of drive shaft (AWD)
- Tighten nuts and bolts on chassis

### Towing a trailer, using a car-top carrier or heavy vehicle loading:

- Re-torque nuts and bolts of drive shaft (AWD)
- Tighten nuts and bolts on chassis

Date: \_\_\_\_\_ Mileage: \_\_\_\_\_

## 120 Months or 100,000 Miles

- Replace engine oil with OW-20 oil; replace oil filter
- Replace engine coolant (see page 70)
- Reset maintenance reminder light
- Rotate tires
- Visually inspect brake pads, calipers and rotors
- Check installation of driver's floor mat
- Road-test vehicle

**If you drive primarily under either of these special operating conditions, perform these additional items:**

### Driving off-road, on dirt roads or on dusty roads:

- Inspect axle shaft boots
- Inspect ball joints and dust covers
- Inspect engine air filter
- Inspect steering linkage and boots
- Re-torque nuts and bolts of drive shaft (AWD)
- Tighten nuts and bolts on chassis

### Towing a trailer, using a car-top carrier or heavy vehicle loading:

- Re-torque nuts and bolts of drive shaft (AWD)
- Tighten nuts and bolts on chassis

Date: \_\_\_\_\_ Mileage: \_\_\_\_\_

## 126 Months or 105,000 Miles

- Clean air conditioner filter
- Inspect and adjust all fluid levels
- Re-torque nuts and bolts of drive shaft (AWD)
- Replace Smart Key battery
- Reset maintenance reminder light
- Rotate tires
- Visually inspect brake pads, calipers and rotors
- Check installation of driver's floor mat
- Road-test vehicle
- Inspect the following:
 

<input type="checkbox"/> Axle shaft boots	<input type="checkbox"/> Rack and pinion assembly
<input type="checkbox"/> Ball joints and dust covers	<input type="checkbox"/> Rear differential oil
<input type="checkbox"/> Body	<input type="checkbox"/> Steering linkage and boots
<input type="checkbox"/> Brake lines and hoses	<input type="checkbox"/> Transfer case oil (AWD)
<input type="checkbox"/> Drive belt	
<input type="checkbox"/> Exhaust pipes and mountings	

**Note:** If OW-20 oil was not used at last oil change, or if you drive primarily under certain special operating conditions, you should also replace the engine oil with OW-20 oil and replace the oil filter. See page 44 for conditions that apply. Some conditions require additional maintenance. See below.

**If you drive primarily under either of these special operating conditions, perform these additional items:**

**Driving off-road, on dirt roads or on dusty roads:**

- Inspect engine air filter
- Tighten nuts and bolts on chassis

**Towing a trailer, using a car-top carrier or heavy vehicle loading:**

- Replace rear differential oil (AWD)
- Replace transfer case oil (AWD)
- Tighten nuts and bolts on chassis

Date: \_\_\_\_\_ Mileage: \_\_\_\_\_



# SCHEDULED MAINTENANCE LOG

## 132 Months or 110,000 Miles

- Replace engine oil with OW-20 oil; replace oil filter
- Reset maintenance reminder light
- Rotate tires
- Visually inspect brake pads, calipers and rotors
- Check installation of driver's floor mat
- Road-test vehicle

**If you drive primarily under either of these special operating conditions, perform these additional items:**

### Driving off-road, on dirt roads or on dusty roads:

- Inspect axle shaft boots
- Inspect ball joints and dust covers
- Inspect engine air filter
- Inspect steering linkage and boots
- Re-torque nuts and bolts of drive shaft (AWD)
- Tighten nuts and bolts on chassis

### Towing a trailer, using a car-top carrier or heavy vehicle loading:

- Re-torque nuts and bolts of drive shaft (AWD)
- Tighten nuts and bolts on chassis

Date: \_\_\_\_\_ Mileage: \_\_\_\_\_

## 138 Months or 115,000 Miles

- Inspect and adjust all fluid levels
- Inspect engine coolant (see page 70)
- Reset maintenance reminder light
- Rotate tires
- Visually inspect brake pads, calipers and rotors
- Check installation of driver's floor mat
- Road-test vehicle

**Note:** If OW-20 oil was not used at last oil change, or if you drive primarily under certain special operating conditions, you should also replace the engine oil with OW-20 oil and replace the oil filter. See page 44 for conditions that apply. Some conditions require additional maintenance. See below.

**If you drive primarily under either of these special operating conditions, perform these additional items:**

### Driving off-road, on dirt roads or on dusty roads:

- Inspect axle shaft boots
- Inspect ball joints and dust covers
- Inspect engine air filter
- Inspect steering linkage and boots
- Re-torque nuts and bolts of drive shaft (AWD)
- Tighten nuts and bolts on chassis

### Towing a trailer, using a car-top carrier or heavy vehicle loading:

- Re-torque nuts and bolts of drive shaft (AWD)
- Tighten nuts and bolts on chassis

Date: \_\_\_\_\_ Mileage: \_\_\_\_\_

## 144 Months or 120,000 Miles

- |  |   |
|--|---|
| <ul style="list-style-type: none"> <li><input type="checkbox"/> Replace engine oil with OW-20 oil; replace oil filter</li> <li><input type="checkbox"/> Re-torque nuts and bolts of drive shaft (AWD)</li> <li><input type="checkbox"/> Replace air conditioner filter</li> <li><input type="checkbox"/> Replace brake fluid</li> <li><input type="checkbox"/> Replace engine air filter</li> <li><input type="checkbox"/> Replace Smart Key battery</li> <li><input type="checkbox"/> Replace spark plugs (use Denso FK20HR11 plugs or equivalent)<sup>1</sup></li> <li><input type="checkbox"/> Inspect the following:             <ul style="list-style-type: none"> <li>___ Axle shaft boots</li> <li>___ Ball joints and dust covers</li> <li>___ Body</li> <li>___ Brake lines and hoses</li> <li>___ Brake rotor thickness and runout</li> <li>___ Drive belt</li> <li>___ Exhaust pipes and mountings</li> <li>___ Fuel lines and connections, fuel tank band and fuel tank vapor vent system hoses</li> </ul> </li> </ul> | <ul style="list-style-type: none"> <li><input type="checkbox"/> Reset maintenance reminder light</li> <li><input type="checkbox"/> Rotate tires</li> <li><input type="checkbox"/> Visually inspect brake pads, calipers and rotors</li> <li><input type="checkbox"/> Check installation of driver's floor mat</li> <li><input type="checkbox"/> Road-test vehicle</li> <li>___ Fuel tank cap gasket</li> <li>___ Rack and pinion assembly</li> <li>___ Rear differential oil (AWD)</li> <li>___ Steering linkage and boots</li> <li>___ Transfer case oil (AWD)</li> <li>___ Transmission for signs of leakage</li> </ul> |
|--|---|

**If you drive primarily under either of these special operating conditions, perform these additional items:**

**Driving off-road, on dirt roads or on dusty roads:**

- Tighten nuts and bolts on chassis

**Towing a trailer, using a car-top carrier or heavy vehicle loading:**

- Replace rear differential oil (AWD)
- Replace transfer case oil (AWD)
- Replace transmission fluid
- Tighten nuts and bolts on chassis

Date: \_\_\_\_\_ Mileage: \_\_\_\_\_

<sup>1</sup>Required under the terms of the Emission Control Warranty.

## 150 Months or 125,000 Miles

- Inspect and adjust all fluid levels
- Reset maintenance reminder light
- Rotate tires
- Visually inspect brake pads, calipers and rotors
- Check installation of driver's floor mat
- Road-test vehicle

**Note:** If OW-20 oil was not used at last oil change, or if you drive primarily under certain special operating conditions, you should also replace the engine oil with OW-20 oil and replace the oil filter. See page 44 for conditions that apply. Some conditions require additional maintenance. See below.

**If you drive primarily under either of these special operating conditions, perform these additional items:**

### Driving off-road, on dirt roads or on dusty roads:

- Inspect axle shaft boots
- Inspect ball joints and dust covers
- Inspect engine air filter
- Inspect steering linkage and boots
- Re-torque nuts and bolts of drive shaft (AWD)
- Tighten nuts and bolts on chassis

### Towing a trailer, using a car-top carrier or heavy vehicle loading:

- Re-torque nuts and bolts of drive shaft (AWD)
- Tighten nuts and bolts on chassis

Date: \_\_\_\_\_ Mileage: \_\_\_\_\_

## 156 Months or 130,000 Miles

- Replace engine oil with OW-20 oil; replace oil filter
- Inspect engine coolant (see page 70)
- Reset maintenance reminder light
- Rotate tires
- Visually inspect brake pads, calipers and rotors
- Check installation of driver's floor mat
- Road-test vehicle

**If you drive primarily under either of these special operating conditions, perform these additional items:**

### Driving off-road, on dirt roads or on dusty roads:

- Inspect axle shaft boots
- Inspect ball joints and dust covers
- Inspect engine air filter
- Inspect steering linkage and boots
- Re-torque nuts and bolts of drive shaft (AWD)
- Tighten nuts and bolts on chassis

### Towing a trailer, using a car-top carrier or heavy vehicle loading:

- Re-torque nuts and bolts of drive shaft (AWD)
- Tighten nuts and bolts on chassis

Date: \_\_\_\_\_ Mileage: \_\_\_\_\_

## 162 Months or 135,000 Miles

- Clean air conditioner filter
- Inspect and adjust all fluid levels
- Re-torque nuts and bolts of drive shaft (AWD)
- Replace Smart Key battery
- Reset maintenance reminder light
- Rotate tires
- Visually inspect brake pads, calipers and rotors
- Check installation of driver's floor mat
- Road-test vehicle
- Inspect the following:
 

<input type="checkbox"/> Axle shaft boots	<input type="checkbox"/> Rack and pinion assembly
<input type="checkbox"/> Ball joints and dust covers	<input type="checkbox"/> Rear differential oil (AWD)
<input type="checkbox"/> Body	<input type="checkbox"/> Steering linkage and boots
<input type="checkbox"/> Brake lines and hoses	<input type="checkbox"/> Transfer case oil (AWD)
<input type="checkbox"/> Drive belt	
<input type="checkbox"/> Exhaust pipes and mountings	

**Note:** If OW-20 oil was not used at last oil change, or if you drive primarily under certain special operating conditions, you should also replace the engine oil with OW-20 oil and replace the oil filter. See page 44 for conditions that apply. Some conditions require additional maintenance. See below.

**If you drive primarily under either of these special operating conditions, perform these additional items:**

**Driving off-road, on dirt roads or on dusty roads:**

- Inspect engine air filter
- Tighten nuts and bolts on chassis

**Towing a trailer, using a car-top carrier or heavy vehicle loading:**

- Replace rear differential oil (AWD)
- Replace transfer case oil (AWD)
- Tighten nuts and bolts on chassis

Date: \_\_\_\_\_ Mileage: \_\_\_\_\_

# SCHEDULED MAINTENANCE LOG

## 168 Months or 140,000 Miles

- Replace engine oil with OW-20 oil; replace oil filter
- Reset maintenance reminder light
- Rotate tires
- Visually inspect brake pads, calipers and rotors
- Check installation of driver's floor mat
- Road-test vehicle

**If you drive primarily under either of these special operating conditions, perform these additional items:**

### **Driving off-road, on dirt roads or on dusty roads:**

- Inspect axle shaft boots
- Inspect ball joints and dust covers
- Inspect engine air filter
- Inspect steering linkage and boots
- Re-torque nuts and bolts of drive shaft (AWD)
- Tighten nuts and bolts on chassis

### **Towing a trailer, using a car-top carrier or heavy vehicle loading:**

- Re-torque nuts and bolts of drive shaft (AWD)
- Tighten nuts and bolts on chassis

Date: \_\_\_\_\_ Mileage: \_\_\_\_\_

## 174 Months or 145,000 Miles

- Inspect and adjust all fluid levels
- Inspect engine coolant (see page 70)
- Reset maintenance reminder light
- Rotate tires
- Visually inspect brake pads, calipers and rotors
- Check installation of driver's floor mat
- Road-test vehicle

**Note:** If OW-20 oil was not used at last oil change, or if you drive primarily under certain special operating conditions, you should also replace the engine oil with OW-20 oil and replace the oil filter. See page 44 for conditions that apply. Some conditions require additional maintenance. See below.

**If you drive primarily under either of these special operating conditions, perform these additional items:**

### **Driving off-road, on dirt roads or on dusty roads:**

- Inspect axle shaft boots
- Inspect ball joints and dust covers
- Inspect engine air filter
- Inspect steering linkage and boots
- Re-torque nuts and bolts of drive shaft (AWD)
- Tighten nuts and bolts on chassis

### **Towing a trailer, using a car-top carrier or heavy vehicle loading:**

- Re-torque nuts and bolts of drive shaft (AWD)
- Tighten nuts and bolts on chassis

Date: \_\_\_\_\_ Mileage: \_\_\_\_\_

## 180 Months or 150,000 Miles

- |  |   |
|--|---|
| <input type="checkbox"/> Replace engine oil with OW-20 oil; replace oil filter       | <input type="checkbox"/> Reset maintenance reminder light                 |
| <input type="checkbox"/> Re-torque nuts and bolts of drive shaft (AWD)               | <input type="checkbox"/> Rotate tires                                     |
| <input type="checkbox"/> Replace air conditioner filter                              | <input type="checkbox"/> Visually inspect brake pads, calipers and rotors |
| <input type="checkbox"/> Replace brake fluid   | <input type="checkbox"/> Check installation of driver's floor mat         |
| <input type="checkbox"/> Replace engine air filter                                   | <input type="checkbox"/> Road-test vehicle                                |
| <input type="checkbox"/> Replace engine coolant (see page 70)                        |   |
| <input type="checkbox"/> Replace Smart Key battery                                   |   |
| <input type="checkbox"/> Inspect the following:                                      |   |
| ___ Axle shaft boots   | ___ Fuel tank cap gasket  |
| ___ Ball joints and dust covers  | ___ Rack and pinion assembly  |
| ___ Body   | ___ Rear differential oil (AWD)   |
| ___ Brake lines and hoses  | ___ Steering linkage and boots  |
| ___ Brake rotor thickness and runout   | ___ Transfer case oil (AWD)   |
| ___ Drive belt   | ___ Transmission for signs of leakage                                     |
| ___ Exhaust pipes and mountings  |   |
| ___ Fuel lines and connections, fuel tank band and fuel tank vapor vent system hoses |   |

**If you drive primarily under either of these special operating conditions, perform these additional items:**

**Driving off-road, on dirt roads or on dusty roads:**

- Tighten nuts and bolts on chassis

**Towing a trailer, using a car-top carrier or heavy vehicle loading:**

- Replace rear differential oil (AWD)
- Replace transfer case oil (AWD)
- Tighten nuts and bolts on chassis

Date: \_\_\_\_\_ Mileage: \_\_\_\_\_

The following descriptions are provided to give you a better understanding of the maintenance services that should be performed on your vehicle. The scheduled maintenance log indicates at which time/mileage intervals each service should be performed. Please note that many maintenance services should be performed only by a qualified technician.

For further information on maintenance services that you can perform yourself, see the maintenance sections of your *Owner's Manual*.

### **Air Conditioner Filter**

Clean or replace at specified intervals. More frequent cleaning or replacement may be required when driving in dusty conditions, heavy traffic areas, urban areas, desert areas or dirt roads. Refer to your *Owner's Manual* for service details.

### **Axle Shaft Boots**

Check the axle shaft boots and clamps for cracks, deterioration and damage. Replace any damaged parts and, if necessary, repack the grease. A qualified technician should perform these operations.

### **Ball Joints and Dust Covers**

Check the suspension and steering linkage ball joints for looseness and damage. Check all dust covers for deterioration and damage. A qualified technician should perform these inspections.

### **Body Inspection**

Visually check for corrosion, scratches and other damage. Check outer body panels, inner panels of the hood and doors, and underneath the vehicle. Apply touch-up paint to any chips and scratches or have them repaired by a qualified technician.

### **Brake Fluid**

Replace using fluid type specified in your *Owner's Manual*. A qualified technician should perform this operation.

### **Brake Lines and Hoses**

Visually inspect for proper installation. Check for chafing, cracks, deterioration and signs of leakage. Replace any deteriorated or damaged parts. A qualified technician should perform these operations.

### Brake Pads, Calipers and Rotors

Check brake pads and rotors for excessive wear; check brake rotors for runout. Check brake calipers for fluid leakage. A qualified technician should perform these inspections.

### Differential Oil

Check for correct oil level and inspect each differential component for signs of leakage. If you discover any leakage, have it repaired immediately by a qualified technician. Refer to your *Owner's Manual* for fluid specifications.

### Drive Belt

Inspect for cracks, excessive wear and oiliness. Check the belt tension and adjust if necessary. Replace the belts if they are damaged.

### Drive Shaft

Re-torque the flange nuts and bolts. A qualified technician should perform this operation.

### Driver's Floor Mat

- Only use the driver's floor mat designed specifically for the model and model year of your vehicle, such as Lexus Genuine floor mats.
- Always properly secure the driver's floor mat using the retaining hooks.
- Never install another floor mat on top of the existing driver's floor mat.
- Never install the driver's floor mat upside down.

### Engine Air Filter

Check for excessive dirt, damage and oiliness. Replace if necessary.



### Engine Coolant

When inspecting, visually check the level of the engine coolant on the see-through reservoir. Add coolant as necessary. When replacing, drain and flush the cooling system and refill with coolant. Always use Genuine Toyota Super Long-Life Coolant or similar high-quality non-silicate, nonamine, non-nitrate, non-borate ethylene-glycol coolant with long-life hybrid organic acid technology (i.e., a combination of low phosphates and organic acids). A qualified technician should perform these operations.

Check the radiator and condenser for blockage by leaves, dirt or insects and clean if necessary. Also check the hose connections for corrosion and condition of installation.

**Note:** Initial replacement of engine coolant is at 120 months/100,000 miles. Replace every 60 months/50,000 miles thereafter.

### Engine Oil and Oil Filter

Replace the oil filter and drain and refill the engine oil at specified intervals. SAE 0W-20 oil is the best choice for good fuel economy and good starting in cold weather. If SAE 0W-20 is not available, SAE 5W-20 may be used; however, it must be replaced with SAE 0W-20 at the next oil change. See your Lexus dealer for oil specifically formulated for your vehicle's engine. For instructions on how to reset the reminder light, refer to your *Owner's Manual*.

**Note:** If you do the majority of your driving under any of the special operating conditions indicated on page 44, you should replace the engine oil and oil filter every six months or 5,000 miles, regardless of the oil used or the certification of the vehicle.

### Exhaust Pipes and Mountings

Visually inspect the exhaust pipes, muffler and hangers for cracks, deterioration and damage. Start the engine and listen carefully for any exhaust leakage. Tighten connections and replace parts as necessary.

### **Fuel Lines and Connections, Fuel Tank Band and Fuel Tank Vapor Vent System Hoses**

Visually inspect for corrosion, damage, cracks, and loose or leaking connections. Tighten connections and replace parts as necessary.

### **Fuel Tank Cap Gasket**

Visually inspect for cracks, deterioration and damage and replace if necessary.

### **Nuts and Bolts on Chassis**

Check that tightness of the seat-mounting bolts and front/rear suspension-member retaining bolts matches torque measurements specified in the *Repair Manual*.

### **Rack and Pinion Assembly**

Inspect the rack and pinion assembly for signs of leakage, damage and loose electrical connections. Tighten connections and if you discover any leakage or damage, have it repaired immediately by a qualified technician.

### **Road Test**

While driving the vehicle, check for proper operation of engine, transmission, brakes and steering. Also check the parking brake, and check for abnormal noise or vibration from any part of the vehicle.

### **Spark Plugs**

Replace at specified interval. Install new plugs of the same type as originally equipped (see your *Owner's Manual*). A qualified technician should perform this operation. **To ensure optimum engine performance, replace only with Denso FK20HR11 plugs or equivalent.**

### **Steering Linkage and Boots**

With the vehicle stopped, check for excessive freeplay in the steering wheel. Inspect the linkage for bending and damage and the dust boots for deterioration, cracks and damage. Replace any damaged parts. A qualified technician should perform these operations.

### Timing Chain

The timing chain requires no periodic inspection.

### Tire-Pressure Warning Sensors

A tire-pressure sensor is mounted on each full-size wheel. These sensors do not require periodic maintenance. When a sensor's long-life lithium battery becomes discharged, the battery should be replaced by a qualified technician following procedures in Lexus service and repair publications.

### Tire Rotation

Tires should be rotated according to the instructions in your *Owner's Manual*. When rotating tires, check tire pressure and check tires for damage and uneven wear. If the spare is not rotated, check the condition and pressure of the spare.

### Transfer Case Oil

Check for correct oil level and inspect each component for signs of leakage. If you discover any leakage, have it repaired immediately by a qualified technician. For correct oil, refer to your *Owner's Manual*.

### Transmission

The transmission and transmission fluid are a completely sealed unit. Therefore, periodic checks and replacement of the transmission fluid are not required, and there is no dipstick on the transmission. Any repairs that require adding or replacing fluid should be performed by a qualified technician following procedures in Lexus service and repair publications.

## VEHICLE IDENTIFICATION

Model \_\_\_\_\_

Body style \_\_\_\_\_

In-service date \_\_\_\_\_

Mileage at delivery \_\_\_\_\_

Selling dealership \_\_\_\_\_

Selling dealership phone number \_\_\_\_\_

Vehicle Identification Number \_\_\_\_\_

Air conditioner filter .....	48-67*, 68
Axle shaft boots .....	48-67*, 68
Ball joints and dust covers .....	48-67*, 68
Body inspection .....	48-67*, 68
Body repairs .....	7
Brakes	
Fluid .....	44, 68
Lines and hoses .....	48-67*, 68
Pads, calipers and rotors .....	48-67*, 69
Complimentary services	
Maintenance services .....	4, 45-46
Other services .....	5-6
Differential oil .....	48-67*, 69
Dispute resolution .....	9-13, 21
Drive belt .....	48-67*, 69
Drive shaft .....	48-67*, 69
Driver's floor mat .....	48-67*, 69
Emergency repairs .....	37-38
Engine air filter .....	48-67*, 69
Engine coolant .....	42, 48-67*, 70
Engine oil and filter .....	42, 48-67*, 70
Exhaust pipes and mountings .....	48-67*, 70
Fuel lines and connections, fuel tank band and fuel tank vapor vent system hoses .....	48-67*, 71
Fuel tank cap gasket .....	48-67*, 71
Inspections, general maintenance .....	42-43

---

\*See scheduled maintenance log for maintenance interval.

Keys .....	8
Lexus Personalized Settings .....	1, 4, 45
Loaner vehicle .....	5
Maintenance	
As related to warranty coverage .....	25, 29, 31, 35, 40
Complimentary first and second services .....	4, 45-46
Explanation of maintenance items .....	68-72
General maintenance and inspections .....	42-43
Importance of maintenance .....	39
Maintenance intervals .....	44
Scheduled maintenance log .....	48-67
Where to obtain maintenance .....	inside front cover, 35, 41
Nuts and bolts on chassis .....	48-67*, 71
Oil change .....	48-67*, 70
Owner responsibilities .....	25, 29, 31, 35-38
Parts replacement .....	7, 16, 25, 31, 36
Pre-delivery service .....	1
Quality control .....	7
Rack and pinion assembly .....	48-67*, 71
Road test .....	48-67*, 71
Roadside assistance .....	1, 6
Service agreements .....	7
Service history .....	7
Smog-check tests .....	26, 32
Spark plugs .....	63, 71
Steering linkage and boots .....	48-67*, 71

---

\*See scheduled maintenance log for maintenance interval.

Timing chain .....	72
Tire inspections .....	42
Tire rotation .....	48-67*, 72
Tire-pressure warning sensors .....	72
Tires, warranty coverage .....	34
Transfer case oil .....	48-67*, 72
Transmission .....	48-67*, 72
Travel protection .....	5
Warranty coverages	
Basic .....	18
California Emission Control .....	28-33
Corrosion perforation .....	19
Coverages at a glance .....	15
Federal Emission Control .....	22-27
General provisions .....	16-17
Powertrain .....	18
Restraint systems .....	18
Tires .....	34
Towing .....	19
What is not covered .....	17, 19-21, 23, 30

---

\*See scheduled maintenance log for maintenance interval.

# Owner Information Change Form

FBC

If your name or address has changed or if you purchased your Lexus as a used vehicle, please complete and mail one of the attached cards, even if your warranty coverage has expired. This will enable Lexus to contact you with important product or safety updates concerning your vehicle. If there is no longer a card attached, please call the Lexus Customer Satisfaction Department at (800) 255-3987.

**Check one:**

- Same owner, name and/or address changed
- Same owner, additional driver who should receive product/safety updates
- New owner, purchased vehicle used from a Lexus dealership on this date: \_\_\_\_\_
- New owner, purchased vehicle used from other than a Lexus dealership on this date: \_\_\_\_\_

Vehicle Identification Number (required to process change)

Today's date:     
Mo. Day Year

Mr.  Mrs.  Ms.  Miss  Dr.

First name M.I. Last name

Company name

Check here if address below is for company:

Street address or P.O. Box Apt. or suite number

City State Zip code

Primary phone number Secondary phone number

E-mail address: \_\_\_\_\_

This information is obtained solely for the use of Lexus. Lexus occasionally sends special promotional offers to registered owners. Check here if you prefer not to receive these offers.







NO POSTAGE  
NECESSARY  
IF MAILED  
IN THE  
UNITED STATES

# BUSINESS REPLY MAIL

FIRST-CLASS MAIL PERMIT NO. 449 TORRANCE, CA

POSTAGE WILL BE PAID BY THE ADDRESSEE

LEXUS  
L202  
ATTN: CUSTOMER SATISFACTION  
PO BOX 2991  
TORRANCE CA 90509-9975

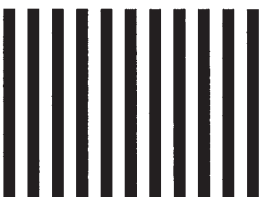

# Owner Information Change Form

FBC

If your name or address has changed or if you purchased your Lexus as a used vehicle, please complete and mail one of the attached cards, even if your warranty coverage has expired. This will enable Lexus to contact you with important product or safety updates concerning your vehicle. If there is no longer a card attached, please call the Lexus Customer Satisfaction Department at (800) 255-3987.

Check one:

- Same owner, name and/or address changed
- Same owner, additional driver who should receive product/safety updates
- New owner, purchased vehicle used from a Lexus dealership on this date: \_\_\_\_\_
- New owner, purchased vehicle used from other than a Lexus dealership on this date: \_\_\_\_\_

Vehicle Identification Number (required to process change)

\_\_\_\_\_

Today's date: \_\_\_\_\_  
Mo. Day Year

Mr.  Mrs.  Ms.  Miss  Dr.

\_\_\_\_\_

First name

\_\_\_\_\_

M.I.

\_\_\_\_\_

Last name

\_\_\_\_\_

Company name

Check here if  
address below  
is for company:

\_\_\_\_\_

Street address or P.O. Box

\_\_\_\_\_

Apt. or suite number

\_\_\_\_\_

City

\_\_\_\_\_

State

\_\_\_\_\_ - \_\_\_\_\_

Zip code

\_\_\_\_\_ - \_\_\_\_\_ - \_\_\_\_\_

Primary phone number

\_\_\_\_\_ - \_\_\_\_\_ - \_\_\_\_\_

Secondary phone number

E-mail address: \_\_\_\_\_

This information is obtained solely for the use of Lexus. Lexus occasionally sends special promotional offers to registered owners. Check here if you prefer not to receive these offers.



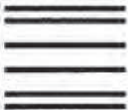

NO POSTAGE  
NECESSARY  
IF MAILED  
IN THE  
UNITED STATES

**BUSINESS REPLY MAIL**

FIRST-CLASS MAIL PERMIT NO. 449 TORRANCE, CA

POSTAGE WILL BE PAID BY THE ADDRESSEE

**LEXUS**  
**L202**  
**ATTN: CUSTOMER SATISFACTION**  
**PO BOX 2991**  
**TORRANCE CA 90509-9975**

