

S2000 2001 Online Reference Owner's Manual

Use these links (and links throughout this manual) to navigate through this reference.
For a printed owner's manual, click on authorized manuals or go to www.helminc.com.

Contents

Owner's Identification Form

Introduction	i
A Few Words About Safety	ii
Your Vehicle at a Glance	2
Driver and Passenger Safety	5
Proper use and care of your vehicle's seat belts, and Supplemental Restraint System.	
Instruments and Controls	41
Instrument panel indicator and gauge, and how to use dashboard and steering column controls.	
Comfort and Convenience Features	85
How to operate the climate control system, the audio system, and other convenience features.	
Before Driving	115
What gasoline to use, how to break-in your new vehicle, and how to load luggage and other cargo.	
Driving	129
The proper way to start the engine, shift the transmission, and park, plus towing a trailer.	
Maintenance	143
The Maintenance Schedule shows you when you need to take your vehicle to the dealer.	
Appearance Care	203
Tips on cleaning and protecting your vehicle. Things to look for if your vehicle ever needs body repairs.	
Taking Care of the Unexpected	213
This section covers several problems motorists sometimes experience, and how to handle them.	
Technical Information	243
ID numbers, dimensions, capacities, and technical information.	
Warranty and Customer Relations (U.S. and Canada)	257
A summary of the warranties covering your new Acura, and how to contact us.	
Authorized Manuals (U.S. only)	263
How to order manuals and other technical literature.	
Index	I

Service Information Summary

A summary of information you need when you pull up to the fuel pump.

Congratulations on your selection of the 2001 Honda S2000. We are certain you will be pleased with your purchase of one of the most sophisticated and technologically-advanced sports cars in the world.

One of the best ways to enhance the enjoyment of your new Honda is to read this manual. In it, you will learn how to operate its driving controls and convenience items. Afterwards, keep this owner's manual in your car so you can refer to it at any time.

Several warranties protect your new Honda. Read the warranty booklet thoroughly so you understand the coverages and are aware of your rights and responsibilities.

Maintaining your car according to the schedules given in this manual helps to keep your driving trouble-free while it preserves your investment. When your car needs maintenance, keep in mind that your Honda dealer's staff is specially trained in servicing the many systems unique to your Honda. Your Honda dealer is dedicated to your satisfaction and will be pleased to answer any questions and concerns.

California Proposition 65 Warning

WARNING: This product contains or emits chemicals known to the State of California to cause cancer and birth defects or other reproductive harm.

As you read this manual, you will find information that is preceded by a **NOTICE** symbol. This information is intended to help you avoid damage to your S2000, other property, or the environment.

A Few Words About Safety

Your safety, and the safety of others, is very important. And operating this car safely is an important responsibility.

To help you make informed decisions about safety, we have provided operating procedures and other information on labels and in this manual. This information alerts you to potential hazards that could hurt you or others.

Of course, it is not practical or possible to warn you about all the hazards associated with operating or maintaining your car. You must use your own good judgement.

You will find this important safety information in a variety of forms, including:

- **Safety Labels** — on the car.
- **Safety Messages** — preceded by a safety alert symbol  and one of three signal words: **DANGER**, **WARNING**, or **CAUTION**.

These signal words mean:

You **WILL** be **KILLED** or **SERIOUSLY HURT** if you don't follow instructions.

You **CAN** be **KILLED** or **SERIOUSLY HURT** if you don't follow instructions.

You **CAN** be **HURT** if you don't follow instructions.

- **Safety Headings** — such as Important Safety Reminders or Important Safety Precautions.
- **Safety Section** — such as Driver and Passenger Safety.
- **Instructions** — how to use this car correctly and safely.

This entire book is filled with important safety information — please read it carefully.

Your Car at a Glance

HEADLIGHTS/TURN SIGNAL SWITCH
(P.51)

WINDSHIELD WIPER CONTROLS
(P.53)

HEATING AND AIR CONDITIONING
(P.86)

HOOD RELEASE
HANDLE
(P.118)

DOOR LOCK
SWITCH
(P.62)

POWER WINDOW
SWITCHES
(P.70)

MIRROR
CONTROLS
(P.80)

AUDIO SYSTEM
(P.94)

ROOF SWITCH
(P.73)

HAZARD WARNING SWITCH
(P.80)

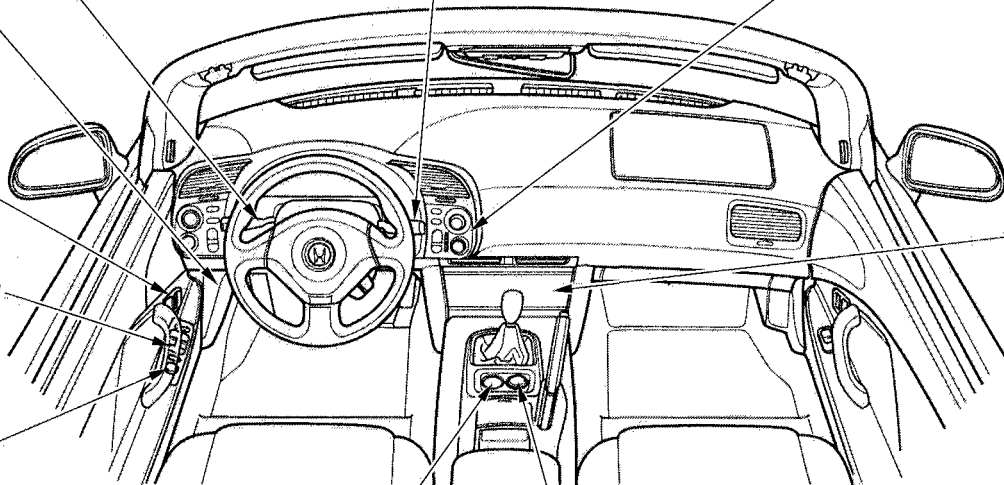

REMOTE AUDIO CONTROLS
(P.113)

INSTRUMENT PANEL BRIGHTNESS
(P.52)

ENGINE START BUTTON
(P.131)

HEADLIGHTS/TURN
SIGNALS
(P.51)

HOOD RELEASE HANDLE
(P.118)

CRUISE CONTROL MASTER SWITCH
(P.55)

WINDSHIELD WIPERS/
WASHERS
(P.53)

HORN

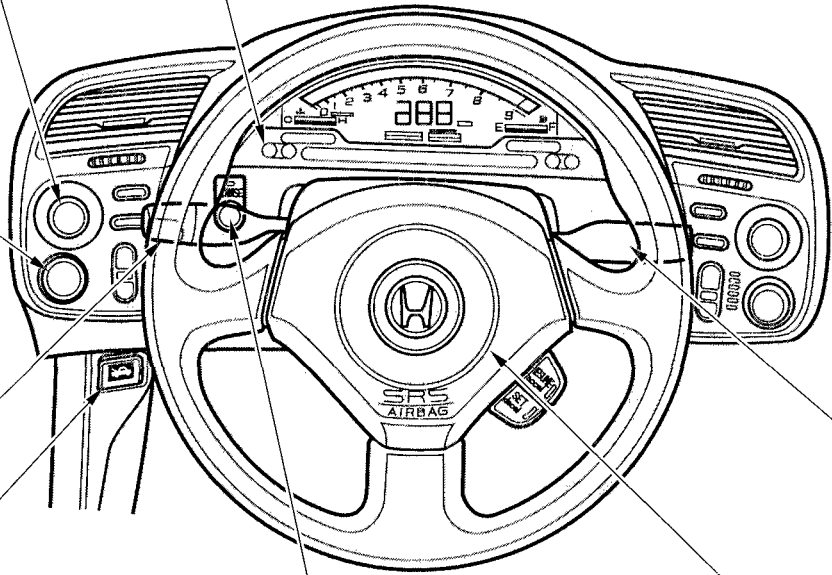

This section gives you important information about how to protect yourself and your passenger. It shows you how to use seat belts properly. It explains your Supplemental Restraint System. And it tells you how to properly restrain children in your car.

Important Safety Precautions	6	General Guidelines for Using	
Your Car's Safety Features	7	Child Seats.....	22
Seat Belts.....	8	Protecting Small Children.....	26
Airbags.....	9	Protecting Larger Children.....	29
Seats & Seat-Backs.....	10	Additional Information About Your	
Head Restraints.....	10	Seat Belts.....	33
Door Locks.....	10	Seat Belt System Components...	33
Pre-Drive Safety Checklist.....	11	Lap/Shoulder Belt.....	33
Protecting Adults.....	12	Seat Belt Maintenance.....	34
1. Close and Lock the Doors.....	12	Additional Information About Your	
2. Adjust the Front Seats.....	12	SRS.....	35
3. Adjust the Seat-Backs.....	13	SRS Components.....	35
4. Fasten and Position the Seat		How Your Airbags Work.....	35
Belts.....	15	How the Automatic Seat Belt	
5. Maintain a Proper Sitting		Tensioners Work.....	37
Position.....	16	How the SRS Indicator Light	
Advice for Pregnant Women.....	17	Works.....	37
Additional Safety Precautions....	18	SRS Service.....	38
Protecting Children.....	19	Additional Safety Precautions....	38
All Children Must Be		Carbon Monoxide Hazard.....	39
Restrained.....	19	Safety Labels.....	40
Your Car is Not Recommended			
for Child Passengers.....	20		
The Passenger's Airbag Poses			
Serious Risks to Children.....	20		
Additional Safety Precaution.....	22		

You'll find many safety recommendations throughout this section, and throughout this manual. The recommendations on this page are the ones we consider to be the most important.

Always Wear Your Seat Belt

A seat belt is your best protection in all types of collisions. Airbags supplement seat belts, but airbags are designed to inflate only in a moderate to severe frontal collision. So even though your car is equipped with airbags, make sure you and your passenger always wear your seat belts, and wear them properly. (See page 15).

Your Car is Not Recommended for Child Passengers

Since all children are safest in the back seat of a car, and your car does not have a back seat, we recommend that you do not carry a child passenger. ***Due to the passenger's***

airbag hazard, you should never carry an infant in a rear-facing child seat in this car. If a small child who must be restrained in a forward-facing child seat, or a larger child, must ride in this car, be sure to follow all instructions and safety warnings in this manual. (See pages 26 and 29.)

Be Aware of Airbag Hazards

While airbags can save lives, they can cause serious or fatal injuries to occupants who sit too close to them, or are not properly restrained. Infants, young children, and short adults are at the greatest risk. Be sure to follow all instructions and warnings in this manual. (See page 7).

Don't Drink and Drive

Alcohol and driving don't mix. Even one drink can reduce your ability to respond to changing conditions, and your reaction time gets worse with

every additional drink. So don't drink and drive, and don't let your friends drink and drive, either.

Control Your Speed

Excessive speed is a major factor in crash injuries and deaths. Generally, the higher the speed the greater the risk, but serious accidents can also occur at lower speeds. Never drive faster than is safe for current conditions, regardless of the maximum speed posted.

Keep Your Car in Safe Condition

Having a tire blowout or a mechanical failure can be extremely hazardous. To reduce the possibility of such problems, check your tire pressures and condition frequently, and perform all regularly scheduled maintenance. (See page 146.)

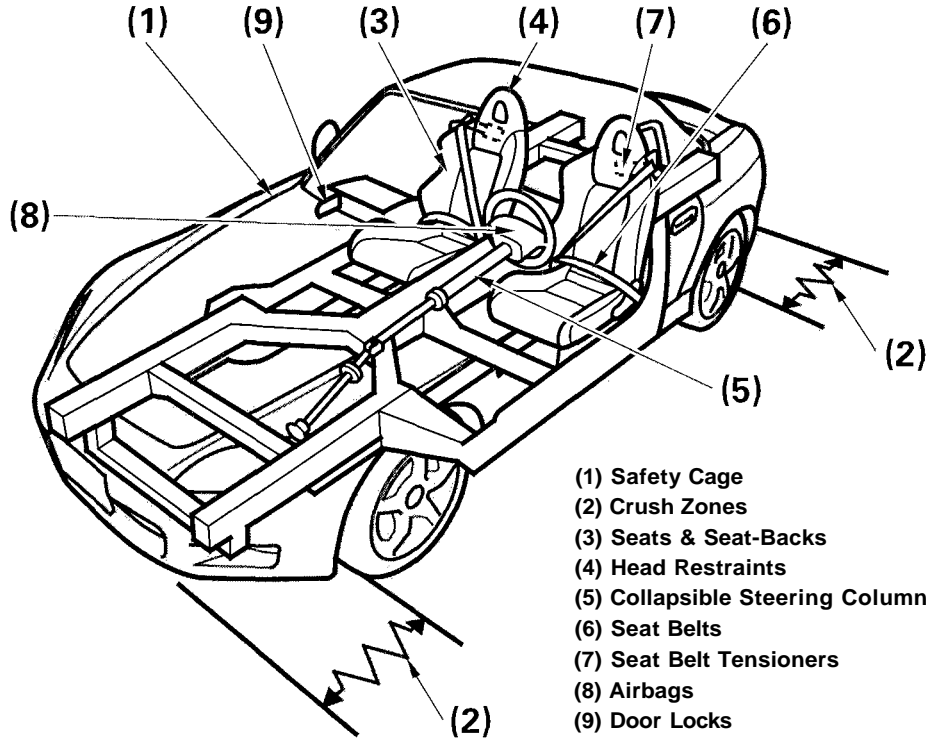

Your car is equipped with many features that work together to protect you and your passenger during a crash.

Some safety features do not require any action on your part. These include a strong steel framework that forms a safety cage around the passenger compartment; front and rear crush zones that are designed to crumple and absorb energy during a crash; a collapsible steering column; and seat belt tensioners that automatically tighten the seat belts in the event of a crash.

These safety features are designed to reduce the severity of injuries in a crash. However, you and your passenger can't take full advantage of these safety features unless you remain sitting in a proper position and ***always wear your seat belts properly***. In fact, some safety features can contribute to injuries if they are not used properly.

Seat Belts

For your safety, and the safety of your passenger, your car is equipped with seat belts in both seating positions.



Your seat belt system also includes a light on the instrument panel to remind you and your passenger to fasten your seat belts.

Why Wear Seat Belts

Seat belts have proven to be the single most effective safety device.

Not wearing a seat belt properly increases the chance of serious injury or death in a crash, even though your car has airbags.

In addition, most states and all Canadian provinces require you to wear seat belts.

Not wearing a seat belt properly increases the chance of serious injury or death in a crash, even if you have airbags.

Be sure you and your passenger always wear seat belts and wear them properly.

When properly worn, seat belts:

- Keep you connected to the vehicle so you can take advantage of the vehicle's built-in safety features.
- Help protect you in almost every type of crash, including side and rear impacts and rollovers. (Your airbag can only be helpful in a

moderate to severe frontal collision.)

- Help keep you from being thrown against the inside of the vehicle and against other occupants.
- Keep you from being thrown out of the vehicle.
- Help keep you in a good position should the airbags ever deploy. A good position reduces the risk of injury from an inflating airbag, and allows you to get the best advantage from the airbag.

Of course, seat belts cannot completely protect you in every crash. But in most cases, seat belts can reduce your risk of serious injury.

What you should do: Always wear your seat belt, and make sure you wear it properly.

Airbags

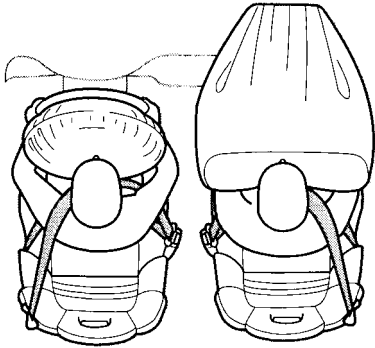

Your car has a Supplemental Restraint System (SRS) with frontal airbags to help protect the driver and a passenger.

SRS

This system also includes an indicator light on the instrument panel to alert you to a possible problem with the system.

The most important things you need to know about your airbags are:

- **Airbags do not replace seat belts.** The seat belts are the occupants' primary protection in all types of collisions. Airbags supplement seat belts by providing extra protection for occupants' heads and chests.
- **Airbags offer no protection in side impacts, rear impacts, rollovers, or minor collisions.** Airbags are designed to deploy only during a moderate to severe frontal collision.

- **Airbags can pose serious hazards.** To do their job, airbags must inflate with tremendous force and speed. So while airbags save lives, they can cause serious injuries to adults and larger children who are not wearing seat belts, are not wearing them properly, are sitting too close to the airbag, or are not sitting in a proper position. Infants and small children are at an even greater risk of injury or death.

What you should do: Always wear your seat belt properly, and sit upright and as far back as possible from the steering wheel or dashboard.

Seats & Seat-Backs

Your car's seats are designed to keep you in a comfortable, upright position so you can take full advantage of the protection offered by seat belts and the energy absorbing materials in the seats.

How you adjust your seats and seat-backs can also affect your safety. For example, sitting too close to the steering wheel or dashboard increases the risk of you or your passenger being injured by striking the inside of the car, or by an inflating airbag.

Reclining a seat-back too far reduces the seat belt's effectiveness and increases the chance that the seat's occupant will slide under the seat belt in a crash and be seriously injured.

What you should do: Move the seats as far back as possible, and keep adjustable seat-backs in an upright position whenever the car is moving.

Head Restraints

Head restraints can help protect you from whiplash and other injuries.

Door Locks

Keeping your doors locked reduces the chance of being thrown out of the car during a crash. It also helps prevent occupants from accidentally opening a door and falling out, and outsiders from unexpectedly opening your doors.

Pre-Drive Safety Checklist

To make sure you and your passenger get the maximum protection from your car's safety features, check the following each time before you drive away:

- You and any adult passenger, or a larger child who has outgrown child seats, are wearing your seat belts and wearing them properly (see page 15).
- A small child riding in a forward-facing child seat is properly restrained (see page 26).
- Occupants are sitting upright and as far back as possible from the steering wheel and dashboard (see page 12).
- Seat-backs are upright (see page 13).

- Both doors are closed and locked (see page 12).
- All cargo is properly stored or secured (see page 124).

The rest of this section gives more detailed information about how you can maximize your safety.

Remember, however, that no safety system can prevent all injuries or deaths that can occur in severe crashes, even when seat belts are properly worn and the airbags deploy.

Introduction

The following pages provide instructions on how to properly protect adult occupants.

These instructions also apply to a child whom you have decided is large enough and mature enough to ride as a passenger. (See page 29 for important additional guidelines on how to properly protect larger children.)

1. Close and Lock the Doors

After everyone has entered the car, be sure the doors are closed and locked.



Your car has a door monitor light on the instrument panel to indicate when a specific door is not tightly closed.

For safety, locking the doors reduces the chance that a passenger, especially a child, will open a door while the car is moving and accidentally fall out. It also reduces the chance of someone being thrown out of the car during a crash.

For security, locked doors can prevent an outsider from unexpectedly opening a door when you come to a stop.

See page 62 for how to lock the doors.

2. Adjust the Front Seats

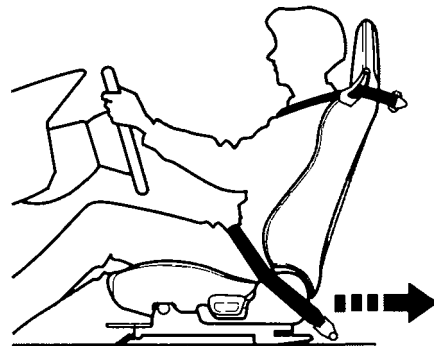

Any driver who sits too close to the steering wheel is at risk of being seriously injured or killed by striking the steering wheel, or from being struck by an inflating airbag during a crash.

To reduce the chance of injury, wear your seat belt properly, sit upright with your back against the seat, and move the seat as far back as possible from the steering wheel while still maintaining full control of the car. Also make sure your passenger moves the seat as far to the rear as possible.

Sitting too close to an airbag can result in serious injury or death if the airbags inflate.

Always sit as far back from the airbags as possible.

Most shorter drivers can get far enough away from the steering wheel and still reach the pedals. However, if you are concerned about sitting too close, we recommend that you investigate whether some type of adaptive equipment may help.

Once your seat is adjusted correctly, rock it back and forth to make sure the seat is locked in position.

See page 69 for how to adjust the seats.

3.Adjust the Seat-Backs

Adjust the driver's seat-back to a comfortable, upright position, leaving ample space between your chest and the airbag cover in the center of the steering wheel. If you sit too close to the steering wheel, you could be injured if the airbag inflates.

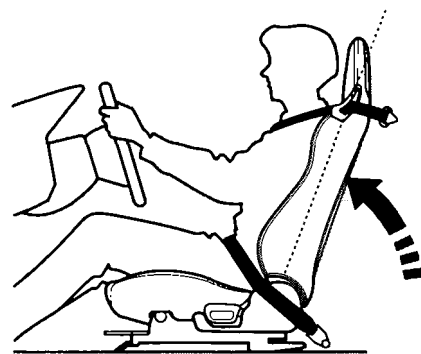

A passenger should also adjust the seat-back to an upright position, but as far from the dashboard as possible. A passenger who sits too close to the dashboard could be injured if the airbag inflates.

CONTINUED

Reclining a seat-back so that the shoulder part of the belt no longer rests against the occupant's chest reduces the protective capability of the belt. It also increases the chance of sliding under the belt in a crash and being seriously injured. The farther a seat-back is reclined, the greater the risk of injury.

Reclining the seat-back too far can result in serious injury or death in a crash.

Adjust the seat-back to an upright position and sit well back in the seat.

See page [69](#) for how to adjust seat-backs.

4. Fasten and Position the Seat Belts

Insert the latch plate into the buckle, then tug on the belt to make sure the belt is securely latched. Also check that the belt is not twisted, because a twisted belt can cause serious injuries in a crash.

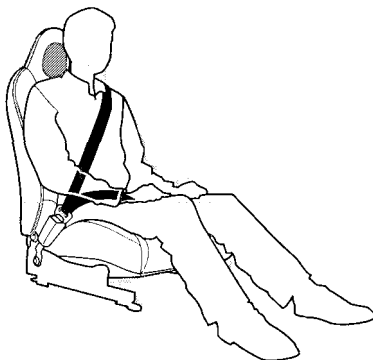

Position the lap part of the belt as low as possible across your hips, then pull up on the shoulder part of the belt so the lap part fits snugly. This lets your strong pelvic bones take the force of a crash and reduces the chance of internal injuries.

If necessary, pull up on the belt again to remove any slack from the shoulder part, then check that the belt rests across the center of your chest and over your shoulder. This

spreads the forces of a crash over the strongest bones in your upper body.

Improperly positioning the seat belts can cause serious injury or death in a crash.

Make sure all seat belts are properly positioned before driving.

Never place the shoulder portion of a lap/shoulder belt under your arm or behind your back. This could cause very serious injuries in a crash.

CONTINUED

If a seat belt does not seem to work as it should, it may not protect the occupant in a crash. ***No one should sit in a seat with an inoperative seat belt.*** Anyone using a seat belt that is not working properly can be seriously injured or killed. Have your Honda dealer check the belt as soon as possible.

See page [33](#) for additional information about your seat belt system and how to take care of your belts.

5. Maintain a Proper Sitting Position

After occupants have adjusted their seats and put on seat belts, it is very important that they continue to sit upright, well back in their seats, with their feet on the floor, until the car is parked and the engine is off.

Sitting improperly can increase the chance of injury during a crash. For example, if an occupant slouches, lies down, turns sideways, sits forward, leans forward or sideways, or puts one or both feet up, the chance of injury during a crash is greatly increased.

In addition, an occupant who is out of position can be seriously or fatally injured by striking interior parts of the car, or by being struck by an inflating airbag.

Sitting improperly or out of position can result in serious injury or death in a crash.

Always sit upright, well back in the seat, with your feet on the floor.

Remember, to get the best protection from your car's airbags and other safety features, you must sit properly and wear your seat belt properly.

Advice for Pregnant Women



Because protecting the mother is the best way to protect her unborn child, a pregnant woman should always wear a seat belt whenever she drives or rides in a vehicle.

Remember to keep the lap portion of the belt as low as possible across your hips.

Pregnant women should also sit upright and as far back as possible from the steering wheel or dashboard. This will reduce the risk of injuries to both the mother and her unborn child that can be caused by a crash or an inflating airbag.

Each time you have a check-up, ask your doctor if it's okay for you to drive.

Additional Safety Precautions

- **Two people should never use the same seat belt.** If they do, they could be very seriously injured in a crash.
- **Do not put any accessories on seat belts.** Devices intended to improve occupant comfort or reposition the shoulder part of a seat belt can severely compromise the protective capability of the seat belt and increase the chance of serious injury in a crash.
- **Do not place hard or sharp objects between yourself and an airbag.** Carrying hard or sharp objects on your lap, or driving with a pipe or other sharp object in your mouth, can result in injuries if your airbags inflate.
- **Keep your hands and arms away from the airbag covers.** If your hands or arms are close to the airbag covers in the center of the steering wheel and on top of the dashboard, they could be injured if the airbags inflate.
- **Do not attach or place objects on the airbag covers.** Any object attached to or placed on the covers marked "SRS AIRBAG," in the center of the steering wheel and on top of the dashboard, could interfere with the proper operation of the airbags. Or, if the airbags inflate, the objects could be propelled inside the car and hurt someone.

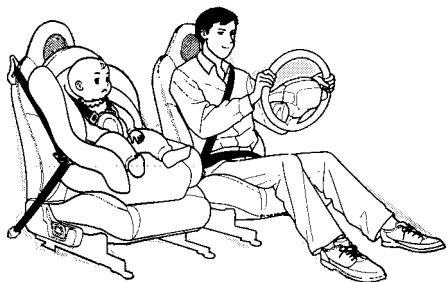

Children depend on adults to protect them. However, despite their best intentions, many parents and other adults may not know how to *properly* protect young passengers.

So if you have children, or if you ever need to drive with a grandchild or other children in your car, be sure to read this section.

Children who are unrestrained or improperly restrained can be seriously injured or killed in a crash.

Any child too small for a seat belt should be properly restrained in a child seat. A larger child should be properly restrained with a seat belt.

All Children Must Be Restrained

Each year, many children are injured or killed in vehicle crashes because they are either unrestrained or not properly restrained. In fact, vehicle accidents are the number one cause of death of children ages 12 and under.

To reduce the number of child deaths and injuries, every state and Canadian province requires that infants and children be restrained whenever they ride in a vehicle.

Any child who is too small to wear a seat belt should be properly restrained in a child seat. (See page [26.](#))

A larger child should always be restrained with a seat belt. (See page [29.](#))

Your Car is Not Recommended for Child Passengers

We strongly recommend that you do not carry any child in this car. One reason is that your car does not have a back seat, and accident statistics show that a child of any size or age is safer when they are properly restrained in the back seat of a vehicle.

In addition, your car has a passenger's airbag which poses serious risks to children — particularly infants and small children.

The Passenger's Airbag Poses Serious Risks to Children

Airbags have been designed to help protect adults in a moderate to severe frontal collision. To do this, the passenger's airbag is quite large, and it inflates with tremendous speed.

As a result, we urge you to follow these guidelines.

Infants

Never put a rear-facing child seat in the front seat of a car equipped with a passenger's airbag. If the airbag inflates, it can hit the back of the child seat with enough force to kill or very seriously injure an infant.

Small Children

Placing a forward-facing child seat in the front seat of a car equipped with a passenger's airbag can be hazardous. If the vehicle seat is too far forward, or the child's head is thrown forward during a collision, an inflating airbag can strike the child with enough force to kill or very seriously injure a small child. If a small child must ride in this car, follow the instructions on page [26](#) .

Larger Children

Children who have outgrown child seats are also at risk of being injured or killed by an inflating passenger's airbag. If a larger child must ride in this car, see page [29](#) for important guidelines on how to decide whether a child is large enough and mature enough to ride as a passenger, and how to properly protect the child.

U.S. Models

To remind you of the passenger's airbag hazards, your car has warning labels on the dashboard and on the driver's and passenger's visors. Please read and follow the instructions on these labels.

⚠ WARNING	
	<p>DEATH or SERIOUS INJURY can occur</p> <ul style="list-style-type: none"> • Children 12 and under can be killed by the air bag • NEVER put a rear-facing child seat in the front • Sit as far back as possible from the air bag • ALWAYS use SEAT BELTS and CHILD RESTRAINTS

⚠ WARNING	
Children Can Be KILLED or INJURED by Passenger Air Bag	
<ul style="list-style-type: none"> • Make sure all children use seat belts or child seats. <p style="text-align: center;">To be removed by owner only.</p>	

Canadian Models

To remind you of the airbag hazards, your car has warning labels on the driver's and passenger's visors. Please read and follow the instructions on these labels.

<p>CAUTION TO AVOID SERIOUS INJURY:</p> <ul style="list-style-type: none"> • FOR MAXIMUM SAFETY PROTECTION IN ALL TYPES OF CRASHES, YOU MUST ALWAYS WEAR YOUR SAFETY BELT. • DO NOT INSTALL REARWARD-FACING CHILD SEATS IN ANY FRONT PASSENGER SEAT POSITION. • DO NOT SIT OR LEAN UNNECESSARILY CLOSE TO THE AIR BAG. • DO NOT PLACE ANY OBJECTS OVER THE AIR BAG OR BETWEEN THE AIR BAG AND YOURSELF. • SEE THE OWNER'S MANUAL FOR FURTHER INFORMATION AND EXPLANATIONS. 	<p>PRÉCAUTIONS: POUR ÉVITER DES BLESSURES GRAVES:</p> <ul style="list-style-type: none"> • POUR PROFITER D'UNE PROTECTION MAXIMALE LORS D'UNE COLLISION BOUCLEZ TOUJOURS VOTRE CEINTURE DE SÉCURITÉ. • N'INSTALLEZ JAMAIS UN SIÈGE POUR ENFANTS FAISANT FACE À L'ARRIÈRE SUR LE SIÈGE DU PASSAGER AVANT. • NE VOUS APPUYEZ PAS ET NE VOUS ASSOYEZ PAS PRÈS DU COUSSIN GONFLABLE. • NE DÉPOSEZ AUCUN OBJET SUR LE COUSSIN GONFLABLE OU ENTRE LE COUSSIN GONFLABLE ET VOUS. • LISEZ LE GUIDE UTILISATEUR POUR DE PLUS AMPLES RENSEIGNEMENTS.
--	--

Additional Safety Precaution

- **Do not leave a child alone in your car.** Leaving a child without adult supervision is illegal in most states and Canadian provinces and can be very hazardous. For example, a small child left in a car on a hot day can die from heatstroke. A child left alone with the key in the ignition can accidentally set the car in motion, possibly injuring themselves or others.
- **Lock both doors and the trunk when your car is not in use.** Children who play in cars can accidentally get trapped inside the trunk. Teach your children not to play in or around cars. Know how to operate the emergency trunk opener (US models only) and decide if your children should be shown how to use this feature (see page [67](#)).

- **Keep car keys and remote transmitters out of the reach of children.** Even very young children learn how to unlock vehicle doors, turn on the ignition, and open the trunk, which can lead to accidental injury or death.

General Guidelines for Using Child Seats

As discussed on page [20](#), because your car does not have a back seat, and because of the passenger's airbag hazard, we strongly recommend that you do not carry a small child as a passenger in this car.

However, if you must carry a small child in this car, the child must be properly restrained in a child seat.

The following pages give general guidelines for selecting and installing a child seat. See page [26](#) for additional information.

Selecting a Child Seat

To provide proper protection, a child seat should meet three requirements:

1. The child seat should meet safety standards. The child seat should meet Federal Motor Vehicle Safety Standard 213 (FMVSS 213) or Canadian Motor Vehicle Safety Standard 213 (CMVSS 213). Look for the manufacturer's statement of compliance on the box and seat.

2. The child seat should be of the proper type and size to fit the child.



Small Children: A child who can sit up without support should be restrained in a forward-facing child seat. See page 26 for additional information on protecting small children.

3. The child seat should fit the passenger's seat.

Due to variations in the design of child seats, vehicle seats, and seat belts, all child seats will not fit all seating positions in all cars.

However, Honda is confident that one or more child seat models can fit and be properly installed in all recommended seating positions in your car.

Before purchasing a child seat, we recommend that parents test the child seat to make sure it fits properly in the passenger's seat. If a previously purchased child seat does not fit, you will need to buy a different one that will fit.

CONTINUED

Placing a Child Seat

This page briefly summarizes Honda's recommendations on where to place a child seat in your car.

Airbags Pose Serious Risks to Children

The passenger's airbag inflates with enough force to kill or seriously injure an infant in a rear-facing child seat.

A small child in a forward-facing child seat is also at risk. If the vehicle seat is too far forward, or the child's head is thrown forward during a collision, an inflating airbag can kill or seriously injure the child.

If a small child must ride in this car, follow the instructions provided in this section.

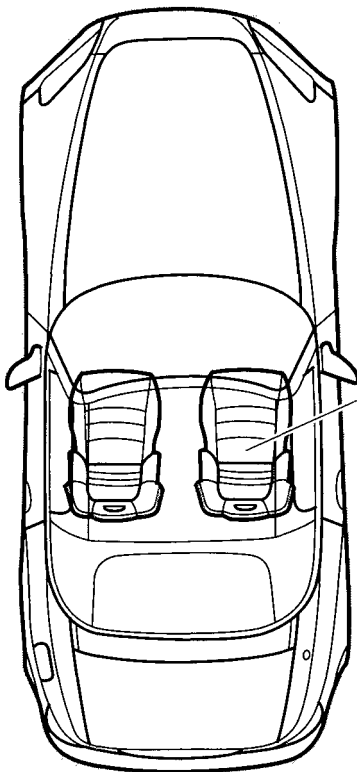

Passenger's Seat

Infants: Never in the passenger's seat, due to the passenger's airbag hazard.

Small children: Not recommended, due to the passenger's airbag hazard. If a small child must ride in this car, move the vehicle seat to the rear-most position and secure a front-facing child seat with the seat belt, (see page [27](#)).

This car is not equipped with a tether attachment point.

Installing a Child Seat

After selecting a proper child seat, there are three main steps in installing the seat:

- 1. Secure the child seat to the car with a seat belt.*** All child seats must be secured to the car with the lap part of a lap/shoulder belt. A child whose seat is not properly secured to the car can be endangered in a crash. See page [27](#) for instructions on how to secure a forward-facing child seat in this car.
- 2. Make sure the child seat is firmly secured.*** After installing a child seat, push and pull the seat forward and from side to side to verify that it is secure.

To provide security during normal driving maneuvers as well as during a collision, we recommend that parents secure a child seat as firmly as possible.

However, a child seat does not need to be "rock solid." It may be difficult to install a child seat so that it does not move at all. Some side-to-side or back-and-forth movement can be expected and should not reduce the child seat's effectiveness.

3. Secure the child in the child seat.

Make sure the child is properly strapped in the child seat according to the child seat maker's instructions. A child who is not properly secured in a child seat can be thrown out of the seat in a crash and be seriously injured.

Storing a Child Seat

When you are not using a child seat, either remove it and store it in a safe place, or make sure it is properly secured. An unsecured child seat can be thrown around the car during a crash or sudden stop and injure someone.

Protecting Small Children



The passenger's airbag poses serious risks to small children. If the vehicle seat is too far forward, or the child's head is thrown forward during a collision, or the child is unrestrained or improperly restrained, an inflating airbag can kill or seriously injure the child.

For these reasons, we recommend that you do not carry a small child as a passenger.

If you decide to carry a small child in this car, follow the instructions and guidelines below.

Child Seat Type

A child who can sit up without support, and who fits within the child seat maker's weight and height limits, should be restrained in a forward-facing, upright child seat.

Of the different seats available, we recommend those that have a five-point harness system as shown.

We also recommend that a small child stay in the child seat as long as possible, until the child reaches the weight or height limit for the seat.

Improperly placing a forward-facing child seat in the front seat can result in serious injury or death if the airbags inflate.

If you must place a forward-facing child seat in front, move the vehicle seat as far back as possible and properly restrain the child.

Child Seat Installation

The passenger's seat belt has a locking mechanism that must be activated to secure a child seat.

The following pages provide instructions and tips on how to secure a forward-facing child seat with this type of seat belt.

1. Move the vehicle seat to the rear-most position. Moving the seat as far back as possible reduces the chance of a child being injured or killed if the passenger's airbag inflates. (See page 69 for instructions on how to adjust the seat.)

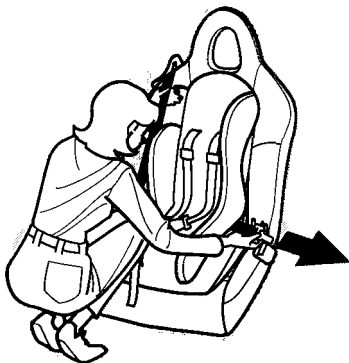

2. With the child seat in position, route the belt through the child seat according to the seat maker's instructions, then insert the latch plate into the buckle.

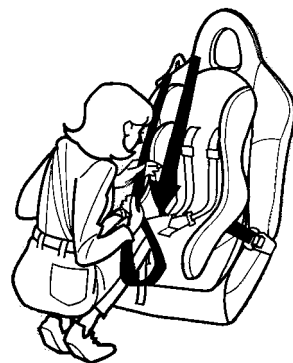

3. To activate the lockable retractor, slowly pull the shoulder part of the belt all the way out until it stops, then let the belt feed back into the retractor (you might hear a clicking noise as the belt retracts).
4. After the belt has retracted, tug on it. If the belt is locked, you will not be able to pull it out. If you can pull the belt out, it is not locked and you will need to repeat these steps.

CONTINUED



5. After confirming that the belt is locked, grab the shoulder part of the belt near the buckle and pull up to remove any slack from the lap part of the belt. Remember, if the lap part of the belt is not tight, the child seat will not be secure. It may help to put weight on the child seat, or push on the back of the seat, while pulling up on the belt.

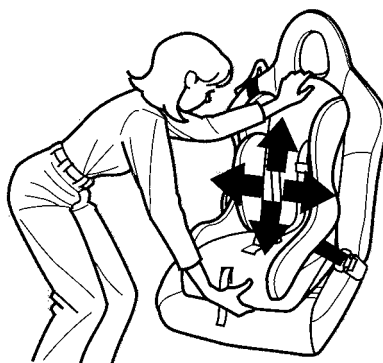

6. Push and pull the child seat forward and from side to side to verify that it is secure enough to stay upright during normal driving maneuvers. If the child seat is not secure, unlatch the belt, allow it to retract fully, then repeat these steps.

To deactivate the locking mechanism in order to remove a child seat, unlatch the buckle, unrout the seat belt, and let the belt fully retract.

Additional Precautions for Small Children

- **Never hold a small child on your lap.** If you are not wearing a seat belt in a crash, you could be thrown forward into the dashboard and crush the child.

If you are wearing a seat belt, the child can be torn from your arms during a crash. For example, if your car crashes into a parked vehicle at 30 mph (48 km/h), a 30-lb (14 kg) child will become a 900-lb (410 kg) force, and you will not be able to hold on.
- **Never put a seat belt over yourself and a child.** During a crash, the belt could press deep into the child and cause very serious injuries.

Protecting Larger Children

The passenger's airbag poses serious risks to children, including those who have outgrown child seats. If the vehicle seat is too far forward, or the child's head is thrown forward during a collision, or the child is unrestrained or out of position, an inflating airbag can kill or seriously injure the child.

For these reasons, we recommend that you do not carry a child passenger.

With this in mind, following are some guidelines to help you decide when a given child may ride in your car.

The Child Should Wear a Seat Belt

When a child reaches the recommended weight or height limit for a forward-facing child seat, the child should wear a lap/shoulder belt.

If a child is too short for the shoulder part of the belt to properly fit, we recommend that the child use a booster seat until the child is tall enough to use the seat belt without a booster.

The following pages give instructions on how to check proper seat belt fit, what kind of booster seat to use if one is needed, and important precautions for a child who must ride in this car.

Allowing a larger child to sit improperly in the front seat can result in injury or death if the airbags inflate.

If a larger child must sit in front, make sure the child moves the seat as far back as possible and wears the seat belt properly.

Checking Seat Belt Fit



To determine if a lap/shoulder belt properly fits a child, have the child put on the seat belt. Follow the instructions on page 15. Then check how the belt fits.

If the shoulder part of the belt rests over the child's collarbone and against the center of the chest, as shown, the child is large enough to wear the seat belt.

CONTINUED

However, if the belt touches or crosses the child's neck, the child needs to use a booster seat.

Do not let a child wear a seat belt across the neck. This could result in serious neck injuries during a crash.

Do not let a child put the shoulder part of a seat belt behind the back or under the arm. This could cause very serious injuries during a crash. It also increases the chance that the child will slide under the belt in a crash and be injured.

Do not put any accessories on a seat belt. Devices intended to improve occupant comfort or reposition the shoulder part of a seat belt, severely compromise the protective capability of the seat belt and increase the chance of serious injury in a crash.

Two children should never use the same seat belt. If they do, they could be very seriously injured in a crash.

Using a Booster Seat



If a child needs a booster seat, we recommend choosing a style that allows the child to use the lap/shoulder belt directly, without a shield, as shown.

Whichever style you select, follow the booster seat maker's instructions.

A child may continue using a booster seat until the tops of the ears are even with the top of the seat-back. A child of this height should be tall enough to use the lap/shoulder belt without a booster.

When Can a Larger Child Ride in this Car

Children vary widely. And while age may be one indicator of when a child can safely ride in this car, there are other important factors you should consider.

Physical Size

Physically, a child must be large enough for the lap/shoulder belt to properly fit over the hips, chest, and shoulder (see pages 15 and 29). If the seat belt does not fit properly, the child should use a booster seat.

Maturity

To safely ride in this car, a child must be able to follow the rules, including sitting properly and wearing the seat belt properly throughout a ride.

CONTINUED

Protecting Children

If you decide that a child can safely ride in this car, be sure to:

- Carefully read the owner's manual and make sure you understand all seat belt instructions and all safety information.
 - Move the vehicle seat to the rear-most position.
 - Have the child sit up straight, back against the seat, and feet on or near the floor.
 - Check that the child's seat belt is properly positioned and secured.
- Supervise the child. Even a mature child sometimes needs to be reminded to fasten the seat belt or sit properly.

Seat Belt System Components

Your seat belt system includes lap/shoulder belts in both seating positions.

The seat belts are also equipped with automatic seat belt tensioners.



The system also includes a light on the instrument panel to remind you and your passenger to fasten your belts. If the driver's seat belt is not fastened before the ignition is turned ON (II), the light will come on and a beeper will also sound. The beeper will stop after a few seconds, but the light will stay on until the driver's seat belt is fastened.

Lap/Shoulder Belt

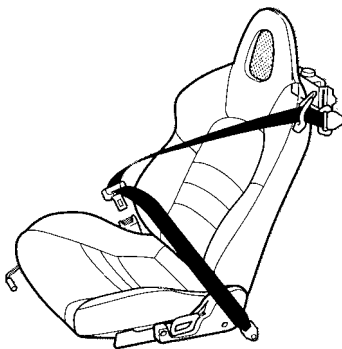

This seat belt has a single belt that goes over your shoulder, across your chest and across your hips.

To fasten the belt, insert the latch plate into the buckle, then tug on the belt to make sure the buckle is latched.

To unlock the belt, push the red PRESS button on the buckle. Guide the belt across your body to the door pillar. After exiting the car, be sure the belt is out of the way and will not

get closed in the door.

Both seat belts have an emergency locking retractor. In normal driving, the retractor lets you move freely in your seat while it keeps some tension on the belt.

During a collision or sudden stop, the retractor automatically locks the belt to help restrain your body.

The passenger's seat belt has an additional locking mechanism that must be activated to secure a child seat. (See page 27 for instructions on how to secure a forward-facing child seat with this type of belt.)

If the shoulder part of the belt is pulled all the way out, the locking mechanism will activate. The belt will retract, but it will not allow the passenger to move freely.

CONTINUED

To deactivate the locking mechanism, unlatch the buckle and let the seat belt fully retract. To refasten the belt, pull it out only as far as needed.

See page 15 for instructions on how to wear the lap/shoulder belt properly.

Seat Belt Maintenance

For safety, you should check the condition of your seat belts regularly.

Pull each belt out fully and look for frays, cuts, burns, and wear. Check that the latches work smoothly and that the lap/shoulder belts retract easily. Any belt not in good condition or not working properly will not provide good protection and should be replaced as soon as possible.

U.S. Models

Honda provides a lifetime warranty on seat belts. Honda will repair or replace any seat belt component that fails to function properly during normal use. Please see your *Honda Warranty Information* booklet for details.

Not checking or maintaining seat belts can result in serious injury or death if the seat belts do not work properly when needed.

Check your seat belts regularly and have any problem corrected as soon as possible.

If a seat belt is worn during a crash, you should have your dealer inspect the belt, and replace it if necessary. A belt that has been worn during a crash may not provide the same level of protection in a subsequent crash. The dealer should also inspect the anchors for damage and replace them if needed.

For information on how to clean your seat belts, see page 208 .

SRS Components

Your Supplemental Restraint System (SRS) includes:

- Two front airbags. The driver's airbag is stored in the center of the steering wheel; the front passenger's airbag is stored in the dashboard. Both are marked "SRS AIRBAG."
- Automatic seat belt tensioners that tighten the front seat belts during a moderate to severe frontal collision.
- Sensors that can detect a moderate to severe frontal collision.
- A sophisticated electronic system that continually monitors information about the sensors, the control unit, and the airbag activators when the ignition is ON (II).

- An indicator light on the instrument panel that alerts you to a possible problem with the system (see page 37).
- Emergency backup power in case your car's electrical system is disconnected in a crash.

How Your Airbags Work

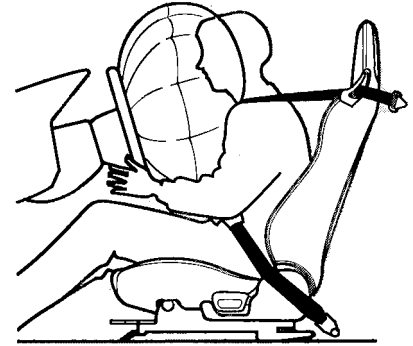

If you ever have a moderate to severe frontal collision, the sensors will detect rapid deceleration and signal the control unit to instantly inflate the airbags and activate the automatic seat belt tensioners.

CONTINUED

During a crash, your seat belt helps restrain your lower body and torso, while the tensioner tightens and locks the seat belt to help keep you in place. Your airbag provides a cushion to help restrain and protect your head and chest.

Since both airbags use the same sensors, both airbags normally inflate at the same time. However, it is possible for only one airbag to inflate.

This can occur when the severity of a collision is at the margin, or threshold, that determines whether or not the airbags will deploy. In such cases, the seat belt will provide sufficient protection, and the supplemental protection offered by the airbag would be minimal.

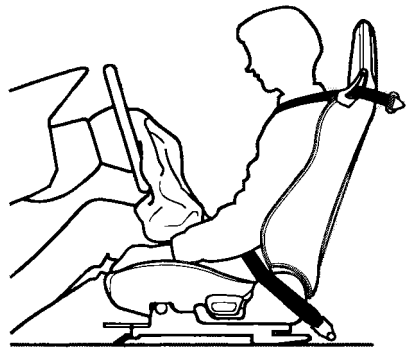

After inflating, the airbags immediately deflate, so they won't interfere with the driver's visibility, or the ability to steer or operate other controls.

The total time for inflation and deflation is approximately one-tenth of a second, so fast that most occupants are not aware that the airbags deployed until they see them lying in their laps.

After a crash, you may see what looks like smoke. This is actually powder from the airbag's surface. Although the powder is not harmful, people with respiratory problems may experience some temporary discomfort. If this occurs, get out of the car as soon as it is safe to do so.

U.S. Owners

For additional information on how your airbags work, see the booklet titled *SRS: What You Need to Know About Airbags* that came with your owner's manual.

Canadian Owners

For additional information on how your airbags work, ask your dealer for a copy of the booklet titled *SRS: What You Need to Know About Airbags*.

How the Automatic Seat Belt Tensioners Work



Your Honda has automatic seat belt tensioners for added protection during a moderate to severe frontal collision.

If your airbags inflate, the tensioners immediately tighten the front seat belts to help hold the occupants in place. The belts will remain tight until you unbuckle them in the normal way.

How the SRS Indicator Light Works

SRS The purpose of the SRS light is to alert you to a potential problem with your Supplemental Restraint System.

When you turn the ignition ON (II), this indicator will light briefly then go out. This tells you that the system is working properly.

If the light comes on at any other time, or does not come on at all, you should have the system checked by your dealer. For example:

- If the SRS indicator light does not come on after you turn the ignition ON (II).
- If the light stays on after the engine starts.

- If the light comes on or flashes on and off while you drive.

If you see any of these indications, your airbags and seat belt tensioners may not deploy when you need them. See your Acura dealer as soon as possible.

Ignoring the SRS indicator light can result in serious injury or death if the airbags do not inflate when needed.

Have your vehicle checked by a dealer as soon as possible if the SRS light alerts you to a potential problem.

SRS Service

Your Supplemental Restraint System is virtually maintenance-free, and there are no parts you can safely service. However, you must have your car serviced if:

- ***Your airbags ever inflate.*** The airbags, seat belt tensioners, and control unit must be replaced. Do not try to remove or replace the airbags yourself. This must be done by a Honda dealer or a knowledgeable body shop.
- ***The SRS indicator light alerts you to a problem.*** Take your car to an authorized Honda dealer as soon as possible. If you ignore this indication, the airbags might not inflate when you need them.

Additional Safety Precautions

- Do not attempt to deactivate your airbags. Together, airbags and seat belts provide the best protection in a moderate to severe frontal collision.
- Do not tamper with SRS components or wiring for any reason. Tampering could cause the airbags to deploy, possibly causing very serious injury.

See page [123](#) for further information and precautions relating to your SRS.

Your car's exhaust contains carbon monoxide gas. You should have no problem with carbon monoxide entering the car in normal driving if you maintain your car properly. Have the exhaust system inspected for leaks whenever:

- The car is raised for an oil change.
- You notice a change in the sound of the exhaust.
- The car was in an accident that may have damaged the underside.



Carbon monoxide gas is toxic. Breathing it can cause unconsciousness and even kill you.

Avoid any enclosed areas or activities that expose you to carbon monoxide.

High levels of carbon monoxide can collect rapidly in enclosed areas, such as a garage. Do not run the engine with the garage door closed. Even with the door open, run the engine only long enough to move the car out of the garage.

With the trunk lid open, air flow can pull exhaust gas into your vehicle's interior and create a hazardous condition. If you must drive with the trunk lid open, open all the windows and set the heating and cooling system as shown below.

If you must sit in your parked car, even in an unconfined area, with the engine running, adjust the heating and cooling system as follows:

1. Push the  button.
2. Select the  mode.
3. Turn the fan on high speed.
4. Set the temperature control to a comfortable setting.

These labels are in the locations shown. They warn you of potential hazards that could cause serious injury. Read these labels carefully.

If a label comes off or becomes hard to read, contact your Honda dealer for a replacement.

DASHBOARD

U.S. models only



SUN VISOR

U.S. models

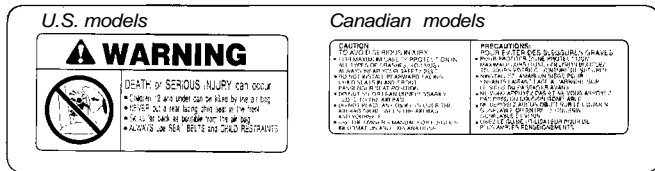

SEAT BELT TENSIONER

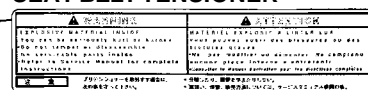

BATTERY

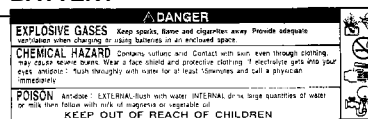

SRS

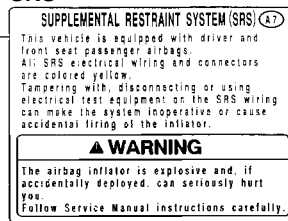

RADIATOR

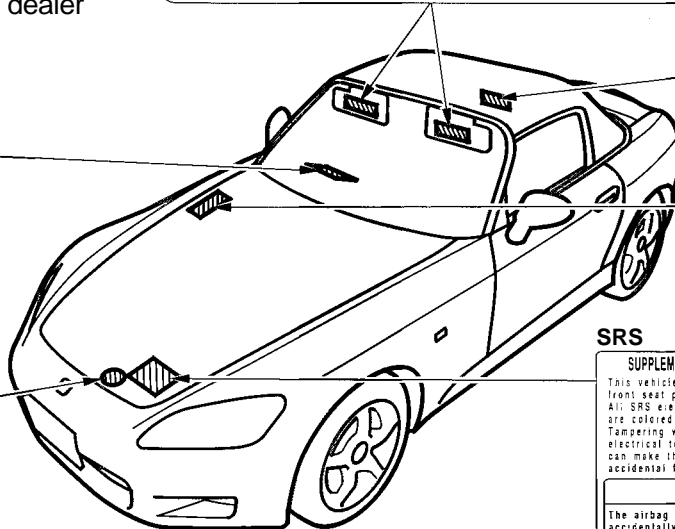

This section gives information about the controls and displays that contribute to the daily operation of your Honda. All the essential controls are within easy reach.

Control Locations.....	42	Power Door Locks.....	62
Indicator Lights.....	43	Remote Transmitter.....	63
Gauges.....	47	Trunk.....	66
Speedometer.....	47	Emergency Trunk Opener.....	67
Select Button.....	47	Console Compartments.....	68
Tachometer.....	47	Seat Adjustments.....	69
Temperature Gauge.....	47	Power Windows.....	70
Fuel Gauge.....	48	Convertible Top.....	72
Odometer.....	48	Lowering the Convertible Top...	72
Trip Meter.....	48	Raising the Convertible Top	75
Maintenance Required		Convertible Top Cover.....	77
Indicator.....	49	Maintenance.....	78
Controls Near the Steering		Hazard Warning.....	80
Wheel.....	50	Mirrors.....	80
Headlights.....	51	Adjusting the Power Mirrors....	80
Daytime Running Lights.....	52	Parking Brake.....	81
Instrument Panel Brightness....	52	Beverage Holder.....	82
Turn Signals.....	53	Accessory Power Socket.....	82
Windshield Wipers.....	53	Audio Panel.....	82
Windshield Washers.....	54	Interior Lights.....	83
Steering Wheel Controls	55		
Cruise Control.....	55		
Keys and Locks.....	58		
Keys.....	58		
Immobilizer System.....	59		
Ignition Switch.....	60		

Control Locations

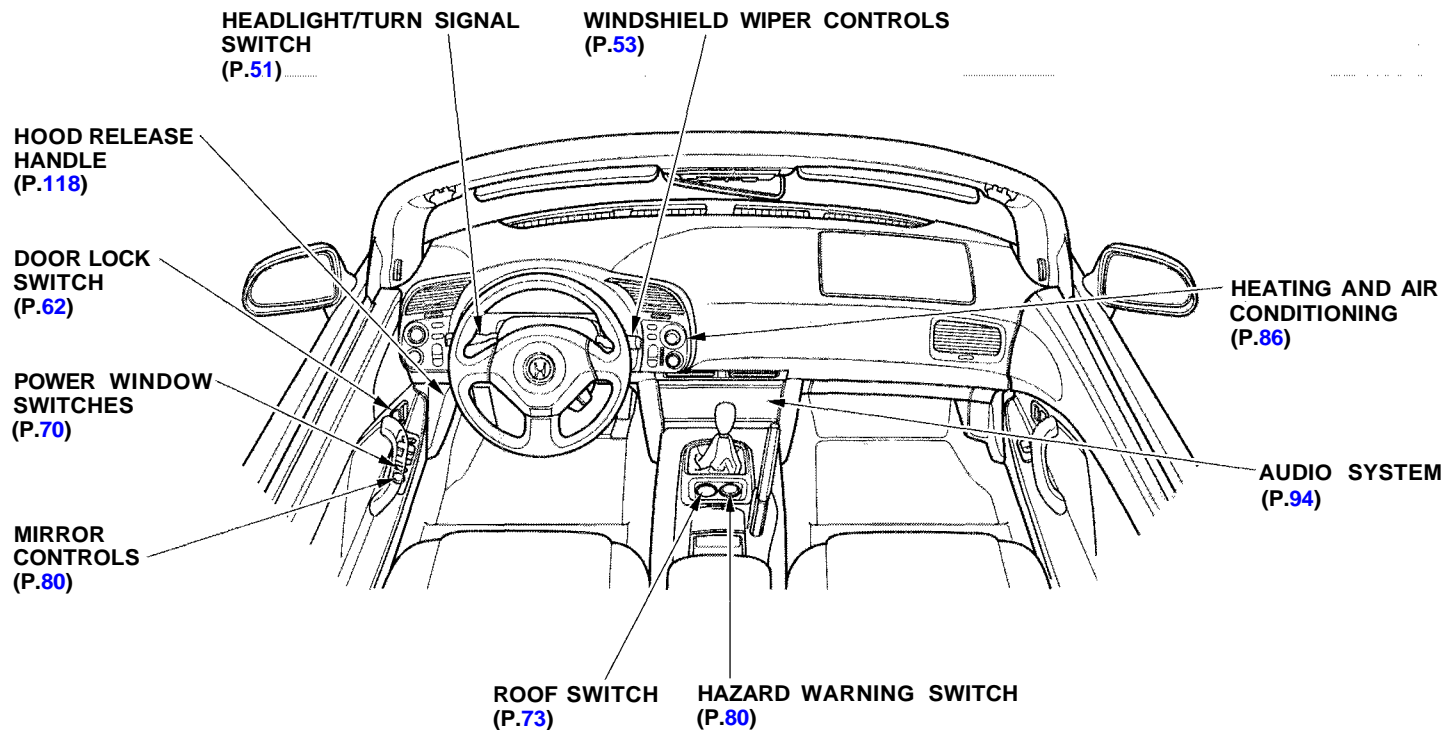

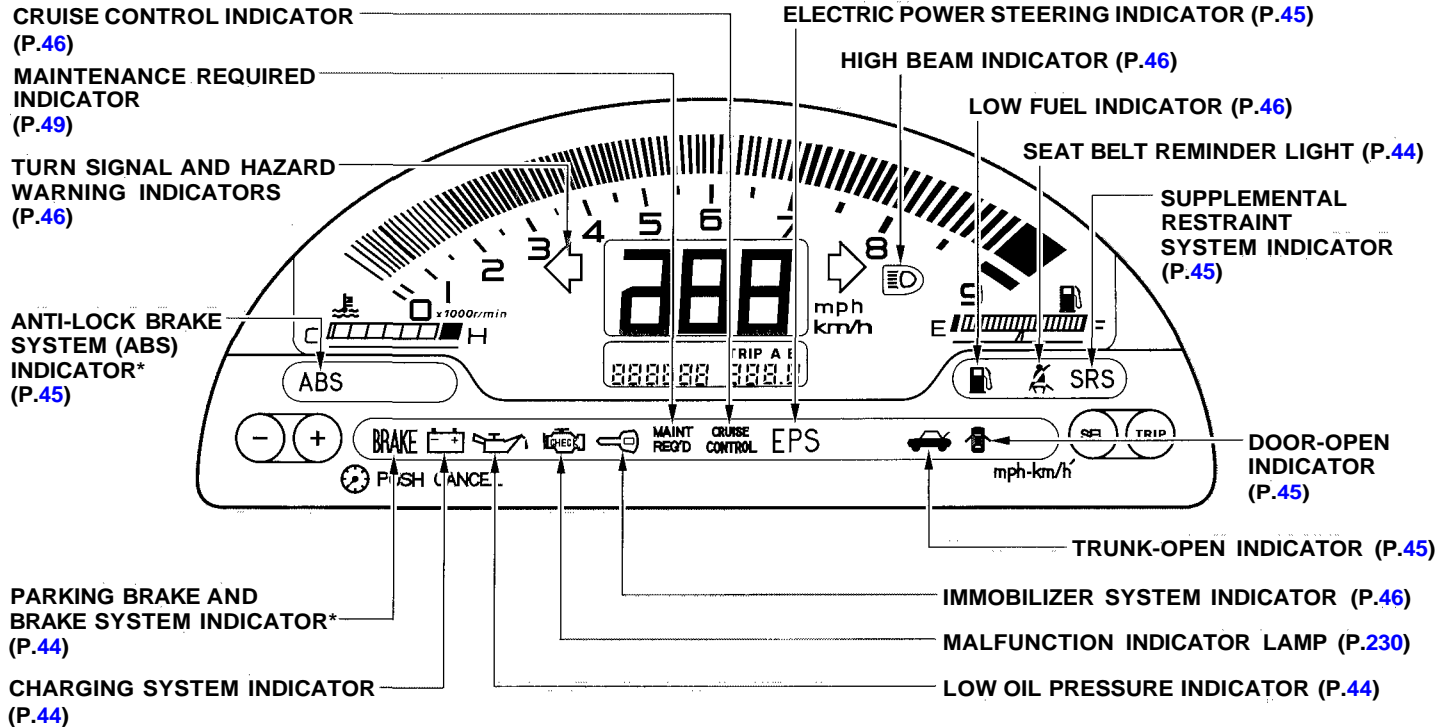

* The U.S. instrument panel is shown. Differences for the Canadian models are noted in the text.

The instrument panel has many indicators to give you important information about your car.



Seat Belt Reminder Light

This indicator flashes for several seconds when you turn the ignition ON (II). It flashes as a reminder to you and your passenger to fasten the seat belts. A beeper also sounds if you have not fastened your seat belt.

If you do not fasten your seat belt, the beeper will stop after a few seconds but the light stays on until you do. Both the light and the beeper stay off if you fasten your seat belt before turning on the ignition.



Low Oil Pressure Indicator

The engine can be severely damaged if this light flashes or stays on when the engine is running. For complete information, see page [228](#).



Charging System Indicator

If this light comes on when the engine is running, the battery is not being charged. For complete information, see page [229](#).

U.S.

BRAKE

Canada



Parking Brake and Brake System Indicator

This light has two functions:

1. This indicator comes on when you turn the ignition switch ON (II). It is a reminder to check the parking brake. Driving with the parking brake not fully released can damage the brakes and tires.
2. If the indicator remains lit after you have fully released the parking brake while the engine is running, or if it comes on while driving, it can indicate a problem in the brake system. For complete information, see page [232](#).

SRS**Supplemental Restraint System Indicator**

This indicator lights when you turn the ignition switch ON (II). If it comes on at any other time, it indicates a problem in the supplemental restraint system. For complete information, see page [37](#).

U.S.

Canada

ABS**Anti-lock Brake System (ABS) Indicator**

This light normally comes on for a few seconds when you turn the ignition switch ON (II), and when you push the START button. If this light comes on at any other time, there is a problem in the ABS. If this happens, take the car to your dealer to have it checked. With the light on, your car still has normal braking ability but no anti-lock.

**Malfunction Indicator Lamp**

See page [230](#).

**Trunk-open Indicator**

This light comes on if the trunk lid is not closed tightly.

**Door-open Indicator**

This light comes on if either door is not closed tightly.

EPS**Electric Power Steering (EPS) Indicator**

This light normally comes on when you turn the ignition ON (II) and goes off after the engine starts. If it comes on at any other time, there is a problem in the Electric Power Steering system. If this happens, stop the car in a safe place and turn off the engine. Reset the system by restarting the engine, and watch the EPS light. If it does not go off, or comes back on again while driving, take the car to your dealer to have it checked. With the light on, the EPS is turned off, making the car harder to steer.



Turn Signal and Hazard Warning Indicators

The left or right turn signal light blinks when you signal a lane change or turn. If the light does not blink or blinks rapidly, it usually means one of the turn signal bulbs is burned out (see page 192). Replace the bulb as soon as possible, since other drivers cannot see that you are signalling.

When you turn on the Hazard Warning switch, both turn signal lights blink. All turn signals on the outside of the car should flash.



High Beam Indicator

This light comes on with the high beam headlights. See page 51 for information on the headlight controls.

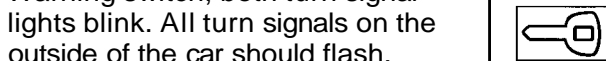

"Daytime Running Lights" Indicator

Canadian models only

This indicator lights when you turn the ignition switch to ON (II) with the headlight switch off and the parking brake set. It should go off if you turn on the headlights or release the parking brake. If it comes on at any other time, it means there is a problem with the DRL. There may also be a problem with the high beam headlights.



Immobilizer System Indicator

This indicator comes on for a few seconds when you turn the ignition switch ON (II). It will then go off if you have inserted a properly-coded ignition key. If it is not a properly-coded key, the indicator will blink and the engine will not start (see page 59).

This indicator also blinks several times when you turn the ignition switch from ON (II) to ACCESSORY (I) or LOCK (0).



Cruise Control Indicator

This lights when you set the cruise control. See page 55 for information on operating the cruise control.



Low Fuel Indicator

This light comes on as a reminder that you must refuel soon.

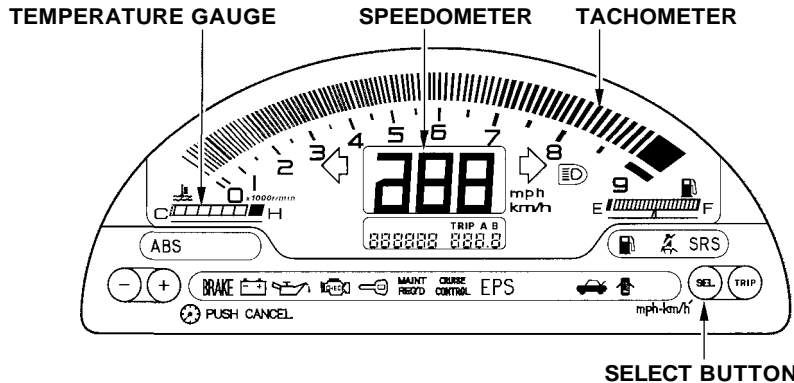

Liquid crystal is used in the meter panel. You may feel the indicators appear slowly in the low temperature.

Speedometer

This shows your speed in miles per hour (mph) or kilometers per hour (km/h).

Select Button

The Select button switches the speedometer reading between miles per hour and kilometers per hour. It also changes the odometer and trip meters to read in miles or kilometers correspondingly. To change the readings, push the Select button and hold it until you hear a beep.

Tachometer

The tachometer shows the engine speed in revolutions per minute (rpm). To protect the engine from damage, never drive with the tachometer reading in the red zone.

Temperature Gauge

This shows the temperature of the engine's coolant. During normal operation, the reading should be in the middle of the gauge. In severe driving conditions, such as very hot weather or a long period of uphill driving, the reading may reach near the red mark. If it reaches the red mark, pull safely to the side of the road. Turn to page [225](#) for instructions and precautions on checking the engine's cooling system.

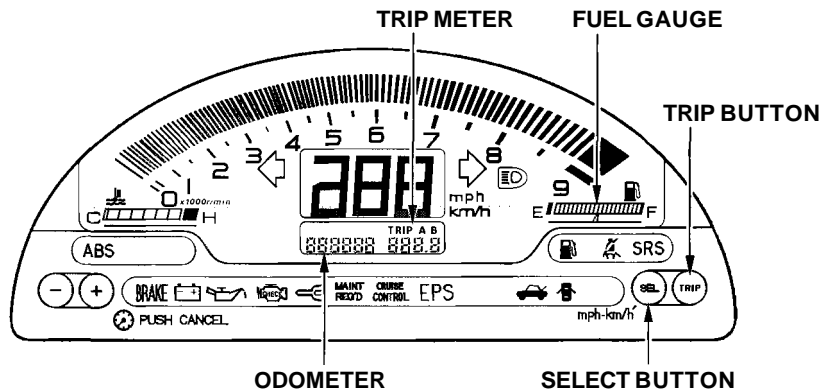

Fuel Gauge

This shows how much fuel you have. It is most accurate when the car is on level ground. It may show slightly more or less than the actual amount when you are driving on curvy or hilly roads.

Odometer

The odometer shows the total distance your car has been driven. It displays in miles and kilometers. It is illegal under U.S. federal law and Canadian provincial regulations to disconnect, reset, or alter the odometer with the intent to change the number of miles or kilometers indicated.

Trip Meter

This meter shows the number of miles or kilometers driven since you last reset it.

There are two trip meters, Trip A and Trip B. Switch between Trip A and Trip B by pressing the TRIP button repeatedly. Each trip meter works independently, so you can keep track of two different distances.

To reset a trip meter, display it and then press and hold the TRIP button until you hear a beep and the number resets to 0.0.

Maintenance Required Indicator

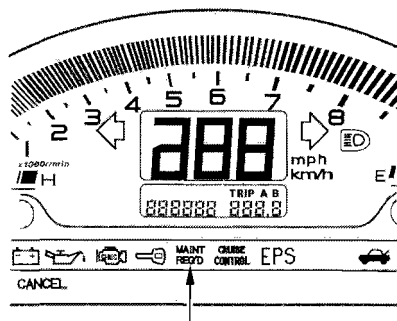

MAINTENANCE REQUIRED INDICATOR

This indicator reminds you that it is time to take your car in for scheduled maintenance. Refer to the Maintenance Schedules for Normal and Severe Driving Conditions on pages [148](#) — [152](#)

When the distance driven since the last scheduled maintenance reaches 6,000 miles (9,600 km), the indicator starts blinking. If you exceed 7,500 miles (12,000 km), the indicator stays on.

Your dealer will reset the indicator when they perform the scheduled maintenance. If someone else performs the maintenance, reset the indicator yourself.

To reset the maintenance required indicator, turn the ignition switch to the LOCK position, then press and hold the trip meter reset button while you turn the ignition switch ON. Continue holding the button until the indicator resets (the indicator light goes out).

Controls Near the Steering Wheel

The two levers on the steering column contain controls for driving features you use most often. The left lever controls the turn signals, headlights, and high beams. The right lever controls the windshield washers and wipers.

The engine start button and the remote audio controls are under the left air vent.

The instrument panel brightness control is in the lower left corner of the speedometer.

The cruise control master switch is to the left of the steering column.

HEADLIGHTS/TURN SIGNALS
(P.51)

INSTRUMENT PANEL BRIGHTNESS
(P.52)

REMOTE AUDIO CONTROLS
(P.113)

ENGINE START BUTTON
(P.131)

HOOD RELEASE HANDLE
(P.118)

HORN

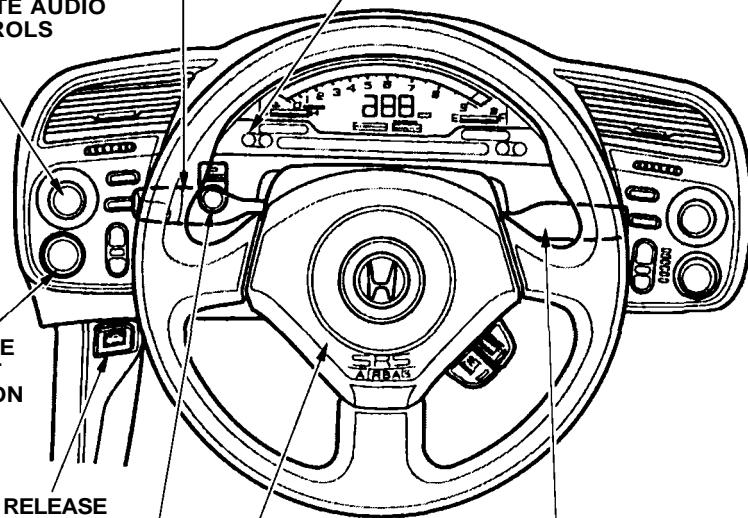

WINDSHIELD WIPERS/WASHERS
(P.53)

CRUISE CONTROL MASTER SWITCH
(P.55)

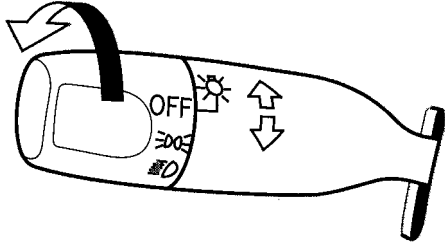

Headlights



The rotating switch on the left lever controls the lights. Turning this switch to the “ ” position turns on the parking lights, taillights, instrument panel lights, side-marker lights, and rear license plate lights. Turning the switch to the “ ” position turns on the headlights.

If you leave the lights on with the ignition switch in ACCESSORY (I) or LOCK (0), you will hear a reminder tone when you open the driver's door.

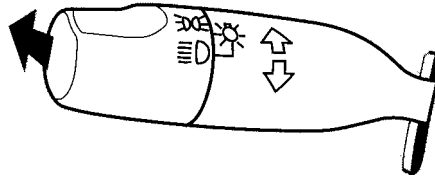

To change from low beams to high beams, push the turn signal lever forward until you hear a click. The blue high beam indicator will light (see page 46). To return to low beams, pull the turn signal lever back.

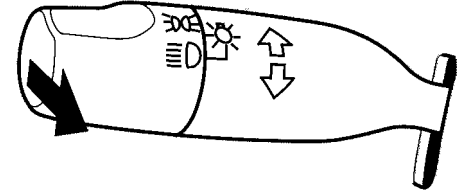

To flash the high beams, pull the turn signal lever back lightly, then release it. The high beams will come on and go off. The high beams will stay on for as long as you hold the lever back, no matter what position the headlight switch is in.

Daytime Running Lights

Canadian models only

With the headlight switch off, the high beam headlights come on with reduced brightness when you turn the ignition switch to ON (II) and release the parking brake. They remain on until you turn the ignition off, even if you set the parking brake.

The headlights revert to normal operation when you turn them on with the switch.

Instrument Panel Brightness

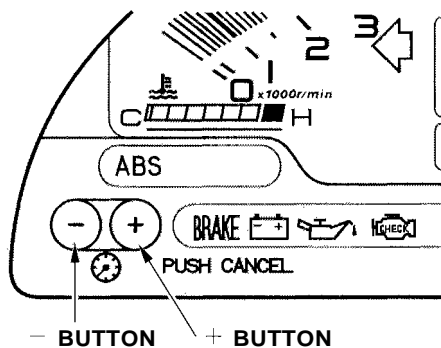

The buttons in the lower left corner of the instrument panel adjust the brightness of the display in five steps. Push the + or — button five times to see the full range.

The display dims when the parking lights or headlights are turned on. Adjust the brightness to the desired level with the headlight switch off, and also with the headlight switch on. Both settings will remain at those levels until you change them.

With the headlight switch on, you can switch the display to full daytime brightness by pushing and holding the + button. Push the — button to return the display to the original brightness.

Turn Signals

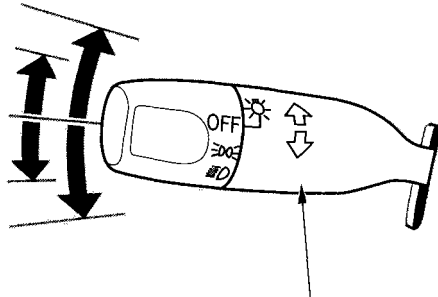

TURN SIGNAL LEVER

Signal a turn or lane change with this lever. Push down on the lever to signal a left turn, and up to signal a right turn. If you push it up or down all the way, the turn signal continues to blink even when you release the lever. It shuts off automatically as you complete the turn.

To signal a lane change, push lightly on the turn signal lever in the proper direction and hold it. The lever will return to the center position as soon as you release it.

Windshield Wipers

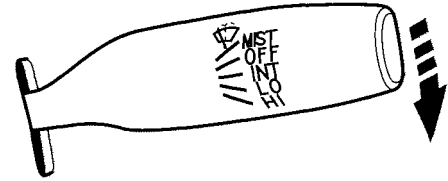

This lever controls the windshield wipers and washers. It has five positions;

- MIST: mist
- OFF: off
- INT: intermittent
- LO: low speed
- HI: high speed

To select a position, push the lever up or down.

CONTINUED

In intermittent, the wipers operate every few seconds. In low speed and high speed, the wipers run continuously.

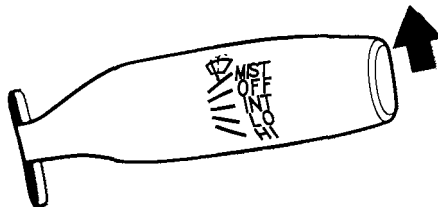

To operate the wipers in mist mode, push the control lever up from the OFF position. The wipers run at high speed until you release the lever. This gives you a quick way to clear the windshield.

Windshield Washers

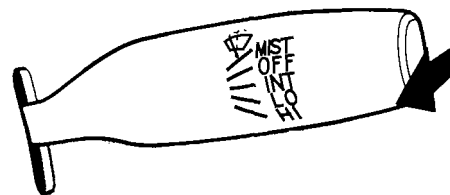

To clean the windshield, pull back on the wiper control lever. The washers spray until you release the lever.

The wipers run at low speed while you're pulling the lever, then complete one more sweep of the windshield after you release it.

Cruise Control

Cruise control allows you to maintain a set speed above 25 mph (40 km/h) without keeping your foot on the accelerator pedal. It should be used for cruising on straight, open highways. It is not recommended for conditions such as city driving, winding roads, slippery roads, heavy rain, or bad weather. You should have full control of the car under those conditions.

Improper use of the cruise control can lead to a crash.

Use the cruise control only when traveling on open highways in good weather.

NOTICE

The cruise control, as it operates, moves the accelerator pedal. You can damage your vehicle's accelerator mechanism by resting your foot under the pedal and blocking the movement.

Using the Cruise Control

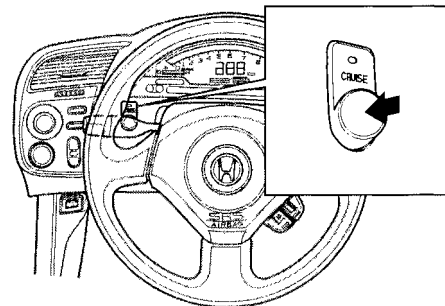

1. Push in the Cruise Control Master Switch on the dashboard beside the steering column. The indicator by the switch will light.
2. Accelerate to the desired cruising speed above 25 mph (40 km/h).

CONTINUED

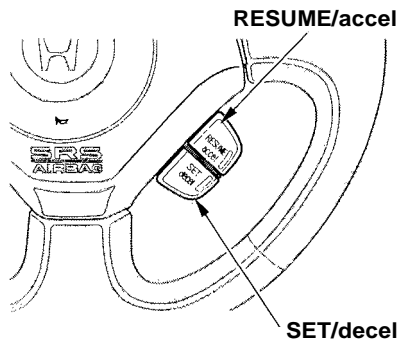

3. Press and release the SET/decel button on the steering wheel. The CRUISE CONTROL light on the instrument panel comes on to show the system is now activated.

The cruise control may not hold the set speed when you are going up and down hills. If your speed increases going down a hill, use the brakes to slow down to the desired speed. This will cancel the

cruise control. To resume the set speed, press the RESUME/accel button. The CRUISE CONTROL light on the instrument panel comes on.

Changing the Set Speed

You can increase the set cruising speed in any of these ways:

- Press and hold the RESUME/accel button. The car will accelerate. When you reach the desired cruising speed, release the button.
- Push on the accelerator pedal. Accelerate to the desired cruising speed and press the SET/decel button.
- To increase your speed in very small amounts, tap the RESUME/accel button repeatedly. Each time you do this, your car will speed up about 1 mph (1.6 km/h).

You can decrease the set cruising speed in any of these ways:

- Press and hold the SET/decel button. The car will decelerate. Release the button when you reach the desired speed.
- To slow down in very small amounts, tap the SET/decel button repeatedly. Each time you do this, your car will slow down about 1 mph (1.6 km/h).
- Tap the brake or clutch pedal lightly with your foot. The CRUISE CONTROL light on the instrument panel will go out. When the car slows to the desired speed, press the SET/decel button. The car will then maintain the desired speed.

Even with the cruise control turned on, you can still use the accelerator pedal to speed up for passing. After completing the pass, take your foot off the accelerator pedal. The car will return to the set cruising speed.

Resting your foot on the brake or clutch pedal will cause the cruise control to cancel.

Cancelling the Cruise Control

You can cancel the cruise control in any of these ways:

- Tap the brake or clutch pedal.
- Press the SET/decel and RESUME/accel buttons at the same time.
- Press the Cruise Control Master Switch.

When you tap the brake or clutch pedal, or press the SET and RESUME buttons at the same time, the CRUISE CONTROL light on the instrument panel will go out and the car will begin to slow down. You can use the accelerator pedal in the normal way.

The system remembers the previously-set cruising speed. To return to that speed, accelerate to above 25 mph (40 km/h), then press the RESUME/accel button. The

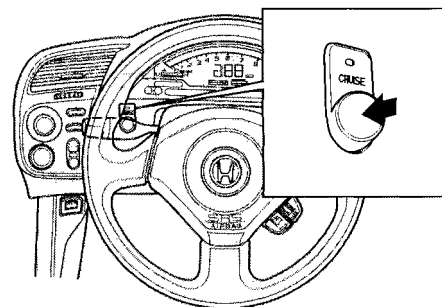

CRUISE CONTROL light comes on, and the car will accelerate to the same cruising speed as before.

Pressing the Cruise Control Master Switch turns the system completely off and erases the previous cruising speed from memory. To use the system again, refer to ***Using the Cruise Control.***

Keys

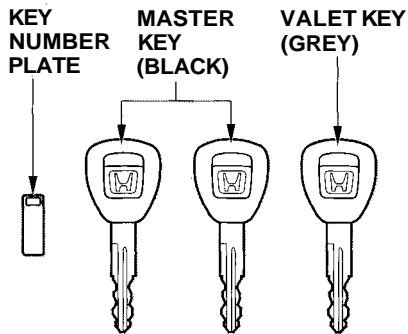

Your car comes with two master keys and a valet key. The master key fits all the locks on your car:

- Ignition
- Doors
- Trunk
- Lower console compartment

The valet key works only in the ignition and the door locks. You can keep the trunk and the lower console compartment locked when you leave your car and the valet key at a parking facility.

You should have received a key number plate with your keys. You will need this key number if you ever have to get a lost key replaced. Keep the plate stored in a safe place. If you need to replace a key, use only Honda-approved key blanks.

These keys contain electronic circuits that are activated by the Immobilizer System. They will not work to start the engine if the circuits are damaged.

- Protect the keys from direct sunlight, high temperature, and high humidity.

- Do not drop the keys or set heavy objects on them.
- Keep the keys away from liquids. If they get wet, dry them immediately with a soft cloth.

The keys do not contain batteries. Do not try to take them apart.

Remote Transmitter

Your car also comes with two remote transmitters; see page 63 for an explanation of the operation.

Immobilizer System

The Immobilizer System protects your car from theft. A properly-coded master or valet key must be used in the ignition switch for the engine to start. If an improperly-coded key (or other device) is used, the engine's fuel system is disabled.

When you turn the ignition switch to ON (II), the Immobilizer System indicator should come on for a few seconds, then go out. If the indicator starts to blink, it means the system does not recognize the coding of the key. Turn the ignition switch to LOCK (0), remove the key, reinsert it, and turn the switch to ON (II) again.

The system may not recognize your key's coding if another immobilizer key or other metal object is near the ignition switch when you insert the key. To make sure the system recognizes the key code:

- Do not keep other immobilizer keys on the same key ring.
- Use a plastic or leather key fob, not metal.
- Keep other keys away from your vehicle's key and the ignition switch while trying to start the engine.

If the system repeatedly does not recognize the coding of your key, contact your Honda dealer.

This indicator will also blink several times when you turn the ignition switch from ON (II) to ACCESSORY (I) or LOCK (0).

Do not attempt to alter this system or add other devices to it. Electrical problems could result that may make your car undriveable.

If you have lost your key and you cannot start the engine, contact your Honda dealer.

CONTINUED

As required by the FCC:

This device complies with Part 15 of the FCC rules. Operation is subject to the following two conditions: (1) This device may not cause harmful interference, and (2) this device must accept any interference received, including interference that may cause undesired operation.

Changes or modifications not expressly approved by the party responsible for compliance could void the user's authority to operate the equipment.

This device complies with Industry Canada Standard RSS-210.

Operation is subject to the following two conditions: (1) this device may not cause interference, and (2) this device must accept any interference that may cause undesired operation of the device.

Ignition Switch

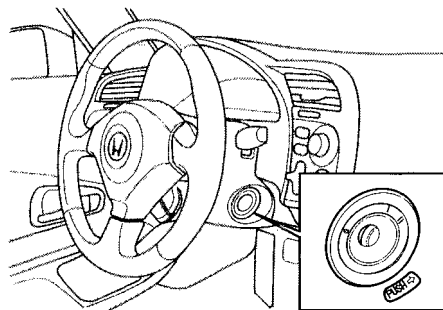

The ignition switch is on the right side of the steering column. It has three positions:

- LOCK (0)
- ACCESSORY (I)
- ON (II)

LOCK (0) - You can insert or remove the key only in this position. To switch from ACCESSORY to LOCK, you must push the key in slightly as you turn it. The anti-theft lock will lock the steering column when you remove the key. If the front wheels are turned, the anti-theft lock may sometimes make it difficult to turn the key from LOCK to ACCESSORY. Firmly turn the steering wheel to the left or to the right as you turn the key.

Removing the key from the ignition switch while driving locks the steering. This can cause you to lose control.

Remove the key from the ignition switch only when parked.

ACCESSORY (I) - In this position, you can operate the audio system and the accessory power socket.

ON (II) — This is the normal key position when driving. All features and accessories on the car are usable. Several of the lights on the instrument panel come on as a test when you turn the ignition switch from ACCESSORY to ON.

The engine can be started with the key in this position by pressing the engine START button (see page [131](#)).

The engine will not start if the Immobilizer System does not recognize the key's coding (see page [59](#)).

You will hear a reminder beeper if you leave the key in the ignition switch in the LOCK (0) or ACCESSORY (I) position and open the driver's door. Remove the key to turn off the beeper.

Power Door Locks

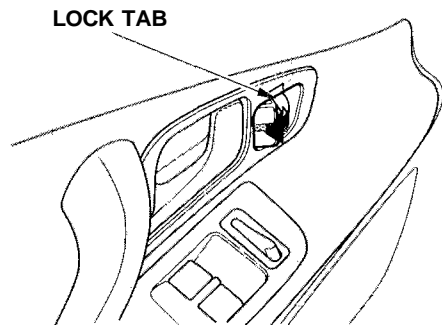

Each door has a lock tab next to the inside door handle. When you push in the lock tab on the driver's door, both doors lock. Pulling out the lock tab on the driver's door only unlocks that door. The lock tab on the passenger's door only locks and unlocks that door.

To lock the passenger's door when getting out of the car, push the lock tab in and close the door. To lock the driver's door, remove the key from the ignition switch, pull out either the inside or outside door handle and push the lock tab in, then close the door.

Both doors lock when you use the key in the driver's door. Using the key in the passenger's door only locks and unlocks that door.

To unlock only the driver's door from the outside, insert the key in the driver's door lock, turn the key and release it. If you turn the key and hold it, both doors will unlock.

Remote Transmitter

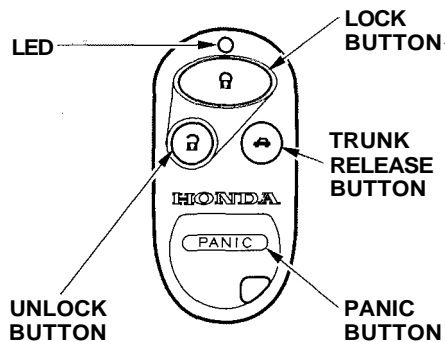

You can lock and unlock your car with the remote transmitter. When you push the LOCK button, both doors lock. The side marker lights and taillights flash once.

When you push the UNLOCK button once, only the driver's door unlocks. The parking lights and taillights flash twice. The passenger's door unlocks when you push the button a second time.

The interior light (if the interior light switch is in the center position) will come on when you press the UNLOCK button. If you do not open either door, the light will go out in about 30 seconds and the doors will automatically relock. If you relock the doors with the remote transmitter before 30 seconds have elapsed, the light will go off immediately.

You cannot lock or unlock the doors with the remote transmitter if either door is not fully closed or the key is in the ignition switch.

To open the trunk, push and hold the TRUNK RELEASE button for approximately one second.

Horn Operation

The horn will sound if you push the LOCK button a second time within five seconds of locking the doors.

CONTINUED

Panic Mode

Panic mode allows you to remotely activate your car's security system to attract attention. When activated, the horn will sound, and the exterior lights will flash for about 30 seconds. To activate panic mode, press and hold the PANIC button for about one second.

To cancel Panic mode before 30 seconds, press any button on the remote transmitter. You can also turn the ignition switch to ON (II).

Replacing the Battery

When the remote transmitter's battery begins to get weak, it may take several pushes on the button to lock or unlock the doors, and the LED will get dim. Replace the battery as soon as possible.

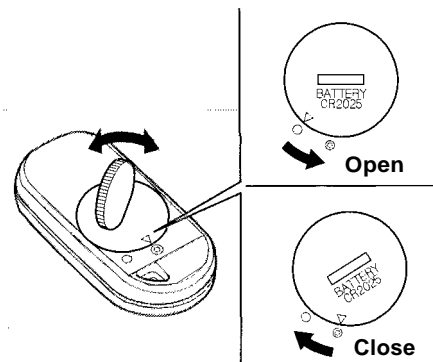

Battery type: CR2025

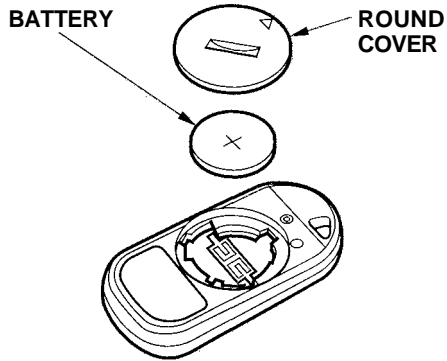

To replace the battery, remove the round cover on the back of the transmitter by turning it counterclockwise with a coin.



Remove the old battery and note the polarity. Make sure the polarity of the new battery is the same (+ side facing up), then insert it in the transmitter.

Align the  mark on the cover with the  mark on the transmitter, then set the cover in place and turn it clockwise.

Transmitter Care

Avoid severe shock to the transmitter, such as dropping or throwing it. Also, protect it from extreme hot or cold temperatures.

Clean the transmitter case with a soft cloth. Do not use strong cleaners or solvents that could harm the case. Immersing the transmitter in any liquid will harm the transmitter and cause it to not function properly.

If you lose a transmitter, you will need to have the replacement programmed to your vehicle's system by your Honda dealer. Any other transmitters you have will also need to be reprogrammed.

As required by the FCC:

This device complies with Part 15 of the FCC rules. Operation is subject to the following two conditions: (1) This device may not cause harmful interference, and (2) this device must accept any interference received, including interference that may cause undesired operation.

Changes or modifications not expressly approved by the party responsible for compliance could void the user's authority to operate the equipment.

This device complies with Industry Canada Standard RSS-210.

Operation is subject to the following two conditions: (1) this device may not cause interference, and (2) this device must accept any interference that may cause undesired operation of the device.

Trunk

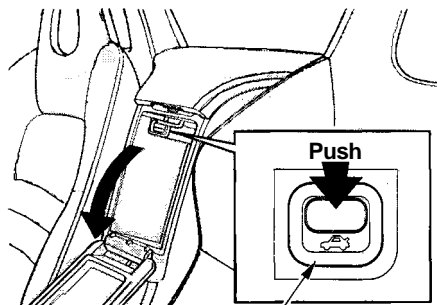

TRUNK RELEASE BUTTON

You can open the trunk in three ways:

- Press the trunk release button in the lower console compartment.
- Use the master key to open the trunk lock. The valet key does not work in this lock.
- Press and hold the trunk release button on the remote transmitter for approximately one second (see page [63](#)).

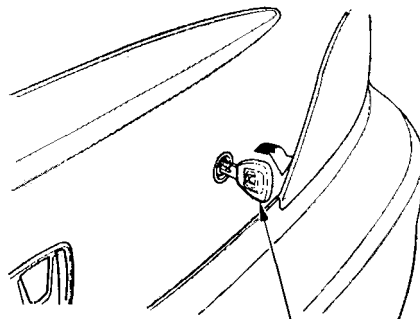

MASTER KEY

To close the trunk, press down on the trunk lid.

To protect items in the trunk when you need to give the key to someone else, lock the lower console compartment with the master key and give the other person the valet key.

See page [124](#) for cargo loading and weight limit information. Keep the trunk lid closed at all times while driving to avoid damaging the lid, and to prevent exhaust gas from getting into the interior. See **Carbon Monoxide Hazard** on page [39](#) .

Emergency Trunk Opener (U.S. models only)

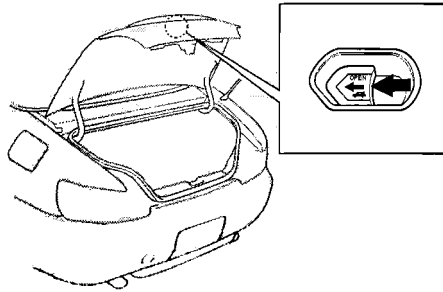

As a safety feature, your car has a release lever on the trunk latch so the trunk can be opened from the inside.

To open the trunk, push the release lever to the left.

Parents should decide if their children should be shown how to use this feature.

For more information about child safety, see page [22](#) .

Console Compartments

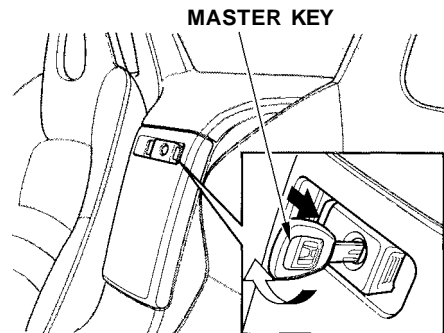

The area between the seats has two compartments. Open the lower compartment by squeezing the handle. Close it with a firm push. You can lock or unlock the lower compartment with the master key.

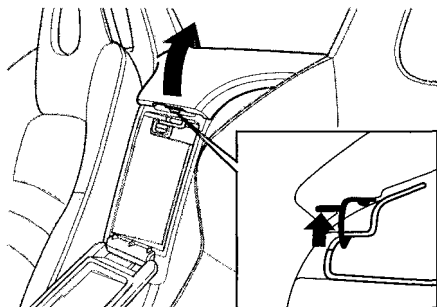

The lever to open the upper compartment is inside the lower compartment. Push up the lever and lift the lid. To close, lower the lid and push it down until it latches.

See pages 12 — 13 for important safety information and warnings about how to properly position seats and seat-backs.

Make all seat adjustments before you start driving.

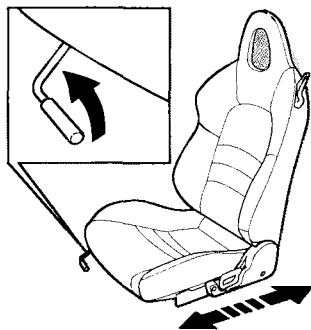

To adjust the seat forward and backward, pull up on the lever under the seat cushion's front edge. Move the seat to the desired position and release the lever. Try to move the seat to make sure it is locked in position.

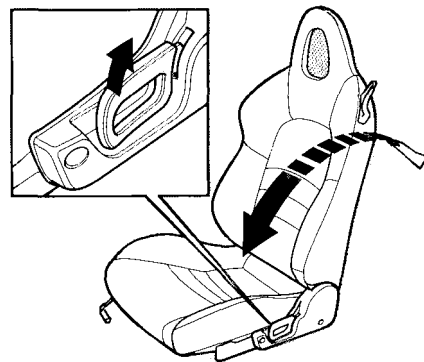

To change the angle of the seat-back, pull up on the lever on the outside of the seat bottom. Move the seat-back to the desired position and release the lever. Let the seat-back latch in the new position.

Power Windows

Your car's windows are electrically-powered. Turn the ignition switch to ON (II) to raise or lower either window.

DRIVER'S WINDOW SWITCH

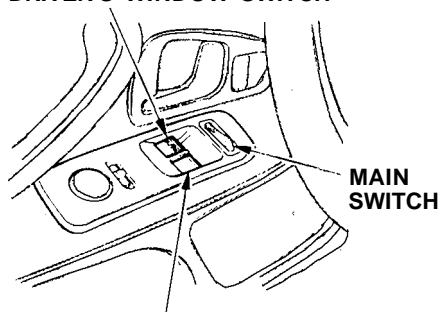

PASSENGER'S WINDOW SWITCH

Each door has a switch that controls its window. To open the window, push the switch down and hold it. Release the switch when you want the window to stop. Close the window by pulling back on the switch and holding it.

The driver's armrest has a master power window control panel. To open the passenger's window, push down on the switch and hold it down until the window reaches the desired position. To close the window, pull back on the window switch. Release the switch when the window gets to the position you want.

Closing a power window on someone's hands or fingers can cause serious injury.

Make sure your passenger is away from the window before closing it.

The master control panel also contains these extra features:

AUTO — To open the driver's window fully, push the window switch firmly down and release it. The window automatically goes all the way down. To stop the window from going all the way down, pull back on the window switch briefly.

To open the driver's window only partially, push the window switch down lightly and hold it. The window will stop as soon as you release the switch.

The AUTO function only works to lower the driver's window. To raise the window, you must pull back on the window switch and hold it until the window reaches the desired position.

The MAIN switch controls power to the passenger's window. With this switch off, the passenger's window cannot be raised or lowered. The MAIN switch does not affect the driver's window. Keep the MAIN switch off when you have a child in the car so the child does not get injured by operating the window unintentionally.

Convertible Top

The convertible top on your Honda lowers and raises electrically.

Before operating the convertible top, make sure the car is parked on level ground, and that there is enough clearance above the top.

It is advisable to raise the top whenever you park the car. This helps to protect the car from unexpected weather changes, and from theft of your valuables.

NOTICE

- *Do not operate the convertible top in freezing weather. You can damage the material and mechanism of the convertible top.*
- *Do not operate the top if it is wet, dirty, or covered with ice or snow.*
- *Never drive the car with the convertible top half open.*

- *Do not lower or raise the top while the engine is running.*
- *Do not operate the convertible top if the car is raised on the jack, a hoist, or on jack stands.*

Lowering the Convertible Top

Park your car in the shade whenever possible.

Extended exposure to sunlight can cause the convertible top to deteriorate.

1. Apply the parking brake. The convertible top will not operate unless the parking brake is fully engaged.
2. Turn the ignition switch to ON (II).

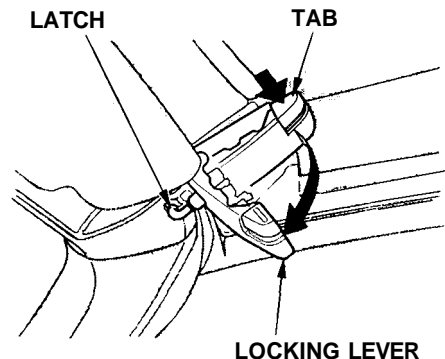

3. There is a latch on each side. Push in the tab and pull the locking lever down.

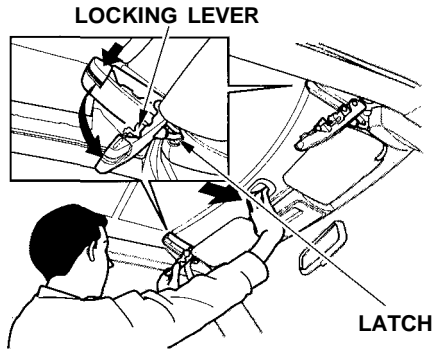

4. Push the top forward while you release the latches from the windshield header by pushing the locking levers forward.

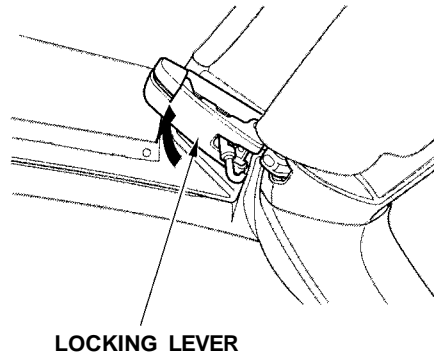

5. With the latches released, pull back on the locking levers and push them up until they latch.

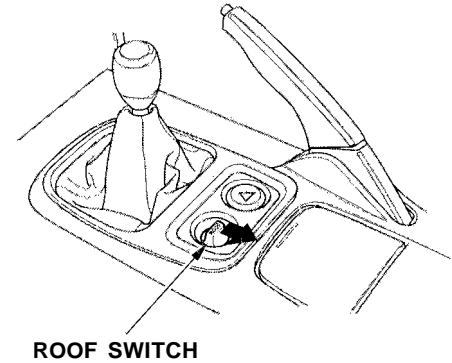

6. Pull back and hold the ROOF switch.

CONTINUED

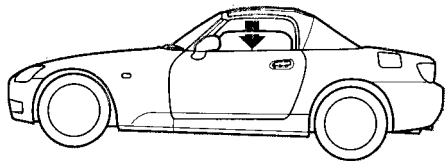

The windows will lower and the roof will fold back. Release the ROOF switch when the roof is retracted completely into the rear shelf.

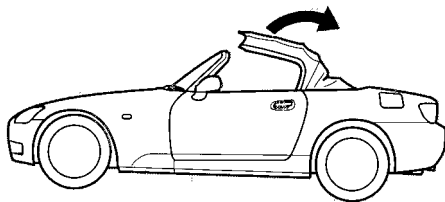

NOTICE

Do not sit on the folded convertible top, or put heavy items on top of it.

Operating the convertible top while any part of a passenger is in the way of the convertible top can cause serious injury.

Make sure that you, your passenger or any other people around the car are clear of the way of the moving convertible top.

Raising the Convertible Top

1. Apply the parking brake. The convertible top will not operate unless the parking brake is fully engaged.
2. Turn the ignition switch to ON (II).

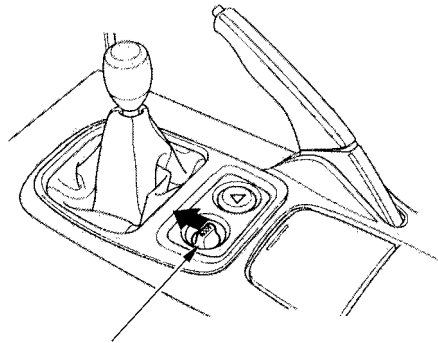

ROOF SWITCH

3. Push the ROOF switch forward and hold it.

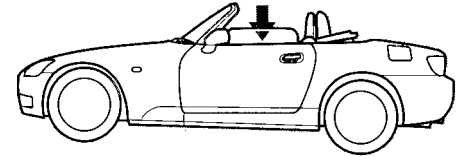

4. The windows, if raised, will lower automatically.

CONTINUED

Convertible Top

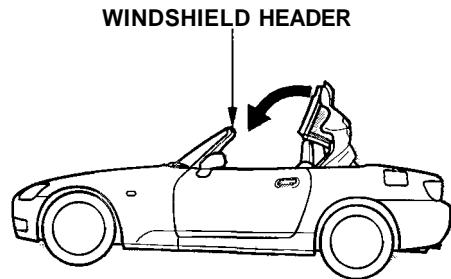

The convertible top will raise. Release the ROOF switch when the top reaches the windshield header.

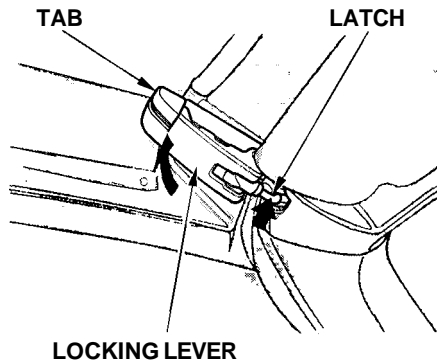

5. Push in the tab on each locking lever and pull the locking lever down.
6. While pushing the convertible top forward, push the locking lever forward and set the latch into the windshield header.
7. Pull back on the locking lever and push it up until it latches. Make sure it is securely latched.

Operating the convertible top while any part of a passenger is in the way of the convertible top can cause serious injury.

Make sure that you, your passenger or any other people around the car are clear of the way of the moving convertible top.

NOTICE

Do not put heavy items on the dosed convertible top. You can damage the material and the mechanism.

Convertible Top Cover

Use the convertible top cover when the top is folded to help prevent foreign objects, dirt, etc., from getting into the material and mechanism.

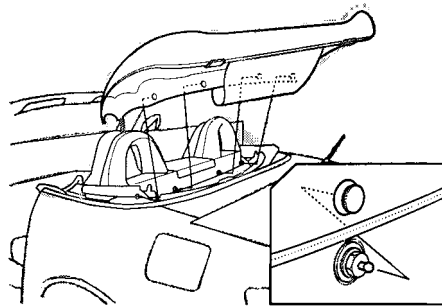

1. Remove the convertible top cover from the trunk.
2. Connect the snaps on the top cover to the four pins on the back of the interior panel.

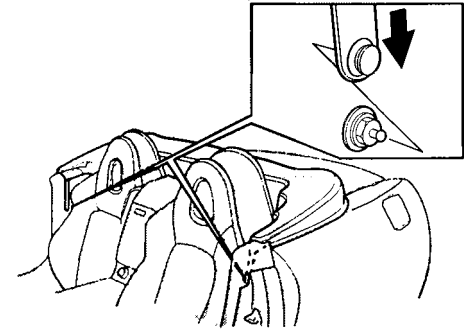

3. Hook the fastener string to the pin on each side wall of the passenger compartment.

CONTINUED

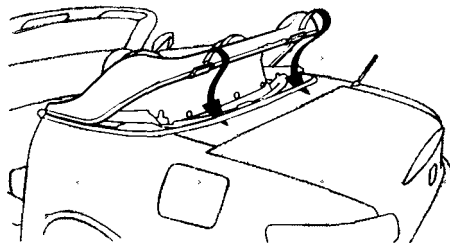

4. Fit deep the rear part of the top cover into the space behind the convertible top.
5. To remove the top cover, reverse the attaching procedure.

Maintenance

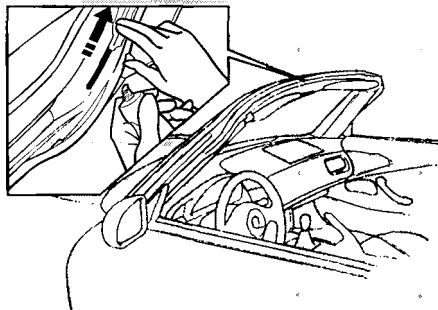

Dust is the main cause of creaks or other sounds coming from the convertible top.

Regularly clean the body seals with glass cleaner and a soft cloth. Do not use a scraper or de-icing chemicals to remove frost, snow, or ice from the top or rear window.

Every three to six months, depending on how often the top is folded, rub a thin film of Shin-Etsu Silicone grease (available from your Honda dealer, P/N 08798-9013) onto the seals wherever they touch the convertible top or each other.

To reduce the possibility of leaks:

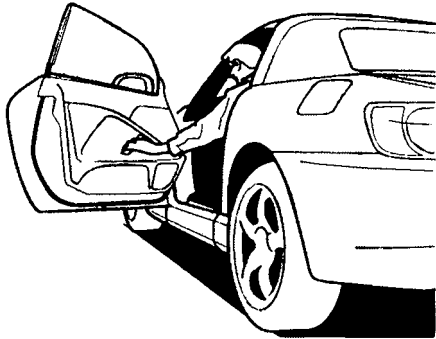

- Use the door pull to open and close the door. Do not push or pull on the door glass.

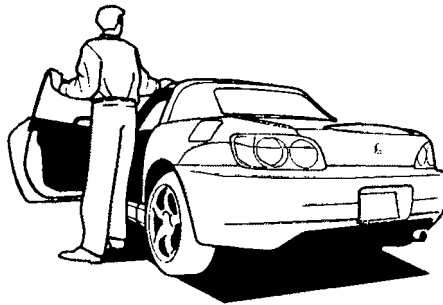

- Do not lean or sit on an open door.

- The convertible top seals are designed to promote the flow of water off the roof. Spraying high pressure water directly on the seals can distort them, causing a leak. Use only a low pressure water stream when using a hose, and avoid car washes.

Hazard Warning

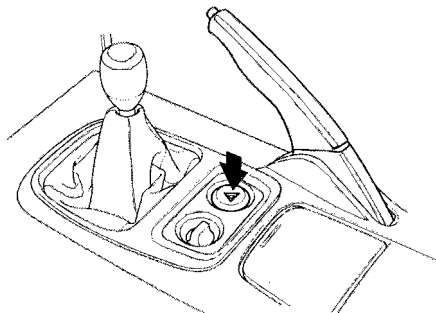

Push the red button next to the roof switch to turn on the hazard warning lights (four-way flashers). This causes all four outside turn signals and both indicators in the instrument panel to flash. Use the hazard warning lights if you need to park in a dangerous area near heavy traffic, or if your vehicle is disabled.

Mirrors

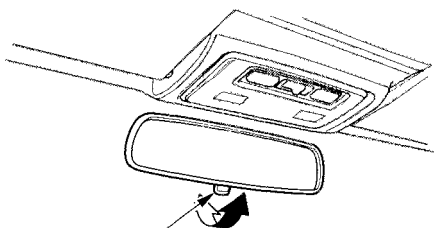

TAB

Keep the inside and outside mirrors clean and adjusted for best visibility. Be sure to adjust the mirrors before you start driving.

The inside mirror has day and night positions. The night position reduces glare from headlights behind you. Flip the tab on the bottom edge of the mirror to select the day or night position.

Adjusting the Power Mirrors

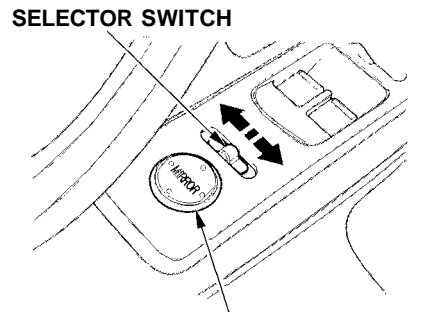

Adjust the outside mirrors with the adjustment switch on the driver's door armrest:

1. Turn the ignition switch ON (II).
2. Move the selector switch to L (driver's side) or R (passenger's side).

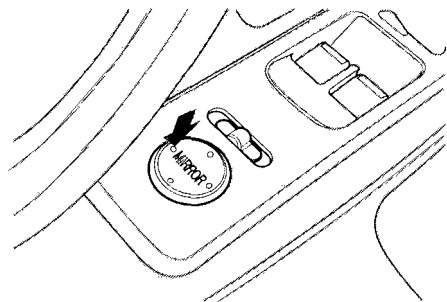

3. Push the appropriate edge of the adjustment switch to move the mirror right, left, up, or down.
4. When you finish, move the selector switch to the center (off) position. This turns off the adjustment switch so you can't move a mirror out of position by accidentally bumping the switch.

Parking Brake

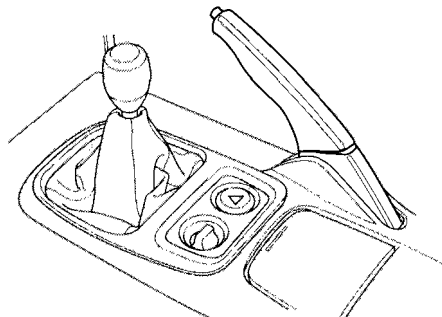

To apply the parking brake, pull the lever up fully. To release it, pull up slightly, push the button, and lower the lever. The parking brake light on the instrument panel should go out when the parking brake is fully released (see page 44). If you try to drive the vehicle without releasing the parking brake, the ABS indicator may come on, and the ABS may not work properly.

NOTICE

Driving the car with the parking brake applied can damage the rear brakes and axles.

Beverage Holder

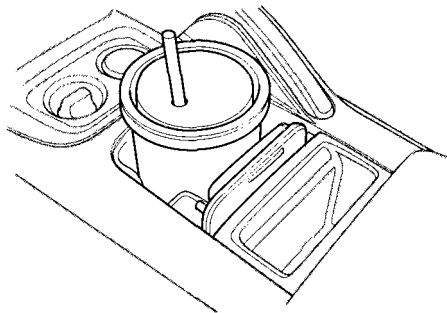

To open the beverage holder, push on the front edge.

Be careful when you are using the beverage holder. A spilled liquid that is very hot can scald you or your passenger. Spilled liquids can also damage the upholstery, carpeting, and electrical components in the interior.

Accessory Power Socket

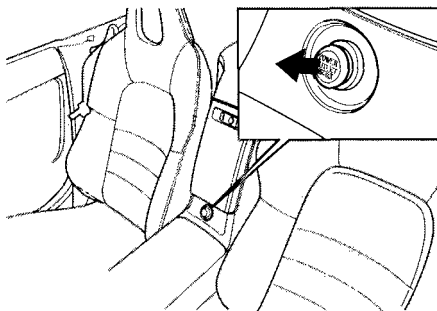

To use the accessory power socket, pull out on the cover. The ignition switch must be in ACCESSORY (I) or ON (II).

This socket is intended to supply power for 12 volt DC accessories that are rated 120 watts or less (10 amps).

It will not power an automotive type cigarette lighter element.

Audio Panel

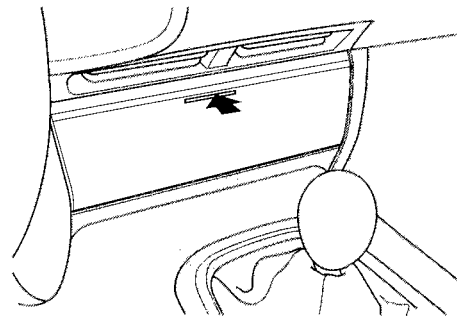

To open the audio panel, push on the top center and let the panel swing down. To close, pivot the panel up and push on it until it latches. Refer to page 94 for operation of the audio system.

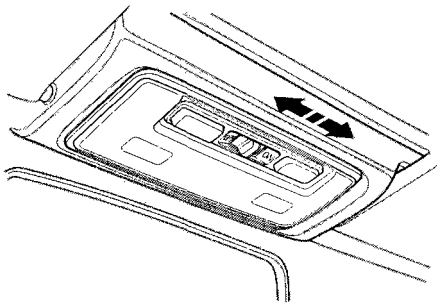

The interior light has a three-position switch. In the OFF position, the light does not come on. In the center position, the interior light comes on when you open either door. In the ON position, the interior light stays on continuously.

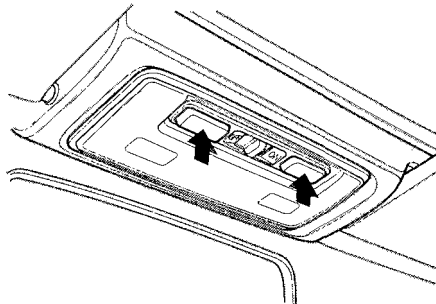

In addition, when the three position switch is in the center position with both doors closed, the two bulbs in the interior light can be turned on separately by the pushbutton switches next to them. Push the switch to turn the light on or off.

If the three-position switch is in the center position, the interior light will come on when you remove the key from the ignition switch.

The heating and air conditioning systems in your Honda provide a comfortable driving environment in all weather conditions.

The standard audio system has many features. This section describes those features and how to use them. (If you selected an optional audio system, refer to the operating instructions that came with it.)

Heating and Cooling.....	86
What Each Control Does.....	86
How to Use the System.....	88
To Turn Everything Off	93
Audio System	
AM/FM/CD Audio System.....	94
Operating the Radio.....	95
Adjusting the Sound.....	99
Digital Clock.....	100
Audio System Lighting.....	102
Radio Frequencies.....	102
Radio Reception.....	103
Operating the CD Player.....	105
Operating the CD Changer.....	108
Protecting Compact Discs.....	109
CD Player Error Indications.....	111
CD Changer Error Indications.....	112
Remote Audio Controls	113
Theft Protection.....	114

Heating and Cooling

Proper use of the Heating and Cooling system can make the interior dry and comfortable, and keep the windows clear for best visibility.

What Each Control Does

Fan Control Lever

Pushing this lever up and down increases and decreases the fan speed. The indicators next to the lever show you the speed selected.

Temperature Control Dial

Turning this dial clockwise increases the temperature of the air flow.

Air Conditioning (A/C) Button

This button turns the air conditioning ON and OFF. The indicator in the button lights when the A/C is on.

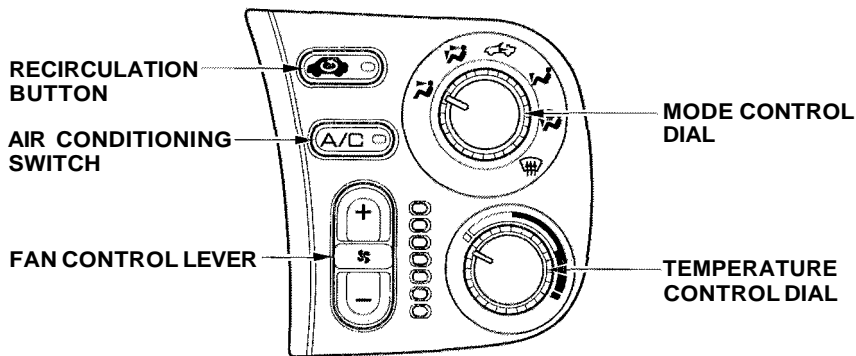



Recirculation Button

This button controls the source of the air going into the system. When the indicator in this button is lit, air from the car's interior is sent through the system again (Recirculation mode). When the indicator is off, air is brought in from outside the car (Fresh Air mode).

Mode Control Dial

Use the MODE control dial to select the vents the air flows from.

 Air flows from the vents on both sides of the instrument panel, and from the dashboard vent in front of the passenger.

 Air flow is divided between the vents in the dashboard and the floor vents.

 Air flows from the center vents in the dashboard above the audio system, the vents on both sides of the instrument panel and from the floor vents. Select this position when you drive with the convertible top folded.

 Air flows from the floor vents and the vents on both sides of the instrument panel.

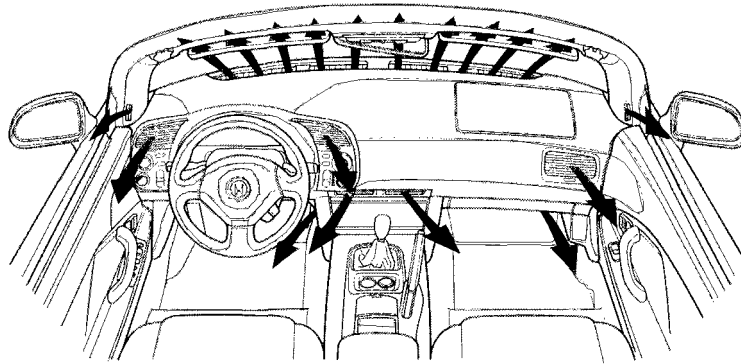

 Air flow is divided between the floor vents, the defroster vents at the base of the windshield and the vents on both sides of the instrument panel.

 Air flows from the defroster vents at the base of the windshield and the vents on both sides of the instrument panel.

When you select  , the system automatically switches to Fresh Air mode and turns on the A/C.

Vent Controls

CENTER VENT

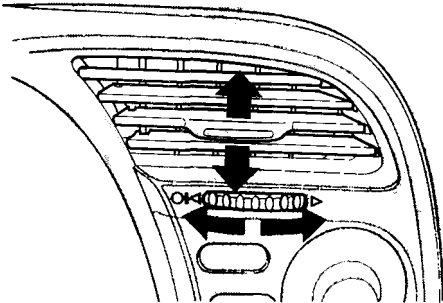

You can adjust the direction of the air coming from the vents on both sides of the instrument panel and at the corner of the dashboard on the passenger's side. To adjust the air flow up and down, move the tab in the center of each vent up and down. To adjust it left and right, turn the dial under each vent left and right.

SIDE VENT

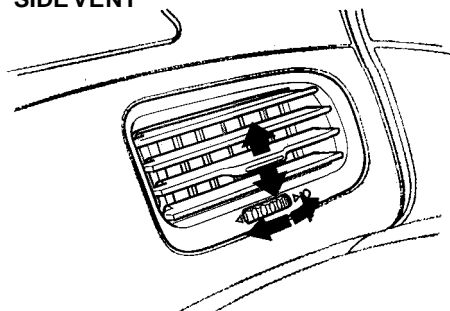

You can shut off the air flow from each vent by turning the dial all the way toward the $\triangleright \text{O}$ mark until it clicks.

How to Use the System

This section covers how to set up the system controls for ventilation, heating, cooling, dehumidifying, and defrosting.

The engine must be running for the heater and air conditioning to generate hot and cold air. The heater uses engine coolant to warm the air. If the engine is cold, it will be several minutes before you feel warm air coming from the system. The air conditioning does not rely on engine temperature.

It is best to leave the system in Fresh Air mode under almost all conditions. Keeping the system in Recirculation mode, particularly with the A/C off, can cause the windows to fog up. Switch to Recirculation mode when you are driving through smoky or dusty conditions, then switch back to Fresh Air mode when the condition clears.

The outside air intakes for the heating and cooling system are at the base of the windshield. Keep these clear of leaves and other debris.

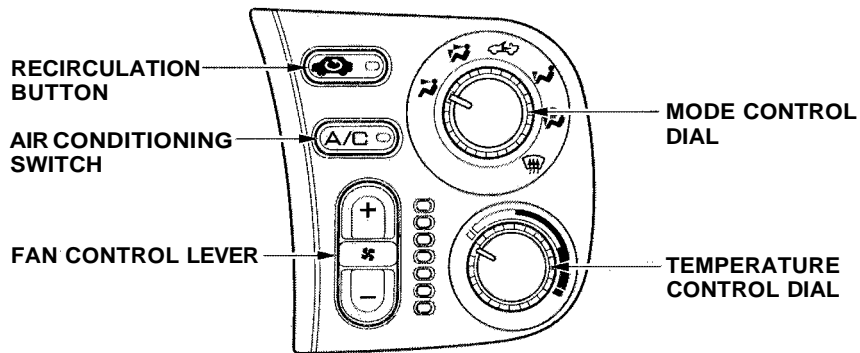

Ventilation

The flow-through ventilation system draws in outside air, circulates it through the interior, then exhausts it through vents behind the seat-backs.

1. Turn the temperature control dial all the way to the left. Make sure the A/C is off.
2. Select  and Fresh Air mode.
3. Set the fan to the desired speed.

CONTINUED

Heating and Cooling

To Cool with A/C

1. Turn on the A/C by pressing the button. The light in the button comes on when a fan speed is selected.
2. Make sure the temperature control dial is all the way to the left.
3. Select 
4. If the outside air is humid, select Recirculation mode. If the outside air is dry, select Fresh Air mode. Set the fan to the desired speed.

If the interior is very warm from being parked in the sun, you can cool it down more rapidly by setting up the controls this way:

1. Start the engine.
2. Turn on the A/C by pressing the button. Make sure the temperature control dial is all the way to the left.
3. Set the fan to maximum speed.
4. Open the windows partially. Select  and Fresh Air mode.

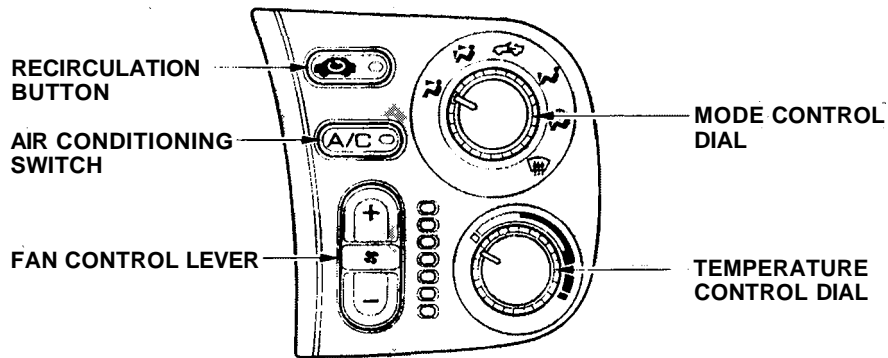

When the interior has cooled down to a more comfortable temperature, close the windows and set the controls as described for normal cooling.

Air conditioning places an extra load on the engine. Watch the engine coolant temperature gauge (see page 47) when driving in stop-and-go traffic or climbing a long, steep hill. If it moves near the red mark, turn off the A/C until the reading returns to normal.

To Heat

To warm the interior:

1. Start the engine.
2. Select  and Fresh Air mode.
3. Set the fan to the desired speed.
4. Adjust the warmth of the air with the temperature control dial.

To Heat and Dehumidify with Air Conditioning



Air conditioning, as it cools, removes moisture from the air. When used in combination with the heater, it makes the interior warm and dry.

1. Switch the fan on.
2. Turn on the air conditioning.
3. Select  and Fresh Air mode.
4. Adjust the temperature control dial so the mixture of heated and cooled air feels comfortable.

This setting is suitable for all driving conditions whenever the outside temperature is above 32°F (0°C).

To Defog and Defrost

To remove fog from the inside of the windows:

1. Switch the fan on.
2. Select  .
When you select  , the system automatically switches to Fresh Air mode and turns on the A/C.
3. Adjust the temperature control dial so the air flow from the defroster vents feels warm.

When you switch to another mode from  , the A/C stays on. Press the A/C button to turn it off.

CONTINUED

Heating and Cooling

To remove exterior frost or ice from the windshield and side windows after the vehicle has been sitting out in cold weather:

1. Start the engine.

2. Select .

When you select , the system automatically switches to Fresh Air mode and turns on the A/C.

3. Switch the fan and temperature controls to maximum.

To rapidly remove exterior frost or ice from the windshield (on very cold days), first select the Recirculation mode. Once the windshield is clear, select the Fresh Air mode to avoid fogging the windows.

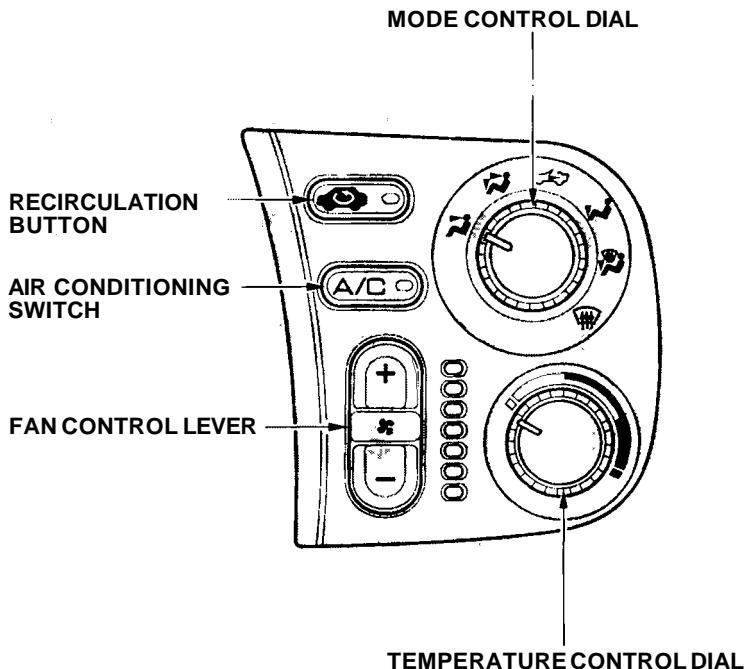

These settings direct all the air flow to the defroster vents at the base of the windshield and the side window defroster vents. The air flow will get warmer and clear the windows faster as the engine warms up. You can close the side vents with the dial beside each vent. This will send more warm air to the windshield defroster vents.

For safety, make sure you have a clear view through all the windows before driving away.

To Turn Everything Off

To shut off the system temporarily, turn off the fan (no lights illuminated).

You should shut the system completely off only for the first few minutes of driving in cold weather, until the engine coolant warms up enough to operate the heater. Keep the fan on at all other times so stale air does not build up in the interior.

Audio System

AM/FM/CD Audio System

Your Honda's audio system provides clear reception on both AM and FM bands, while the preset buttons allow you to easily select your favorite stations.

The anti-theft feature will disable the system if it is disconnected from the vehicle's battery. To get the system working again, you must enter a code number (see page [114](#)).

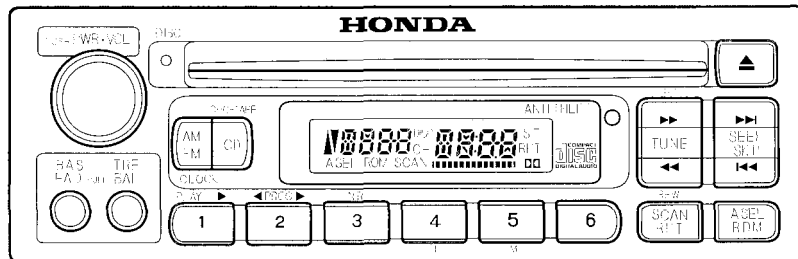





Operating the Radio

The ignition switch must be in ACCESSORY (I) or ON (II) to operate the audio system. Turn the system on by pushing the PWR/VOL knob. Adjust the volume by turning the same knob.

The band and frequency that the radio was last tuned to is displayed. To change bands, press the AM/FM button. On the FM band, ST will be displayed if the station is broadcasting in stereo. Stereo reproduction on AM is not available.

You can use any of four methods to find radio stations on the selected band: TUNE, SEEK, SCAN or the Preset buttons.

TUNE — Use the TUNE bar to tune the radio to a desired frequency. Press the  side of the bar to tune to a higher frequency, and the  side to tune to a lower frequency. The frequency numbers will start to change rapidly. Release the bar when the display reaches the desired frequency. To change the frequency in small increments, press and release the TUNE bar quickly.

SEEK — The SEEK function searches the band for a station with a strong signal. To activate it, press the SEEK bar on either the  or  side, then release it. Depending on which side you press, the system scans upward or downward from the current frequency. It stops when it finds a station with a strong signal.

CONTINUED

SCAN — The SCAN function samples all the stations with strong signals on the selected band. To activate it, press the SCAN button, then release it. When the system is in the SCAN mode, SCAN shows in the display. The system will scan up the band for a station with a strong signal. When it finds one, it will stop and play that station for approximately five seconds. If you do nothing, the system will then scan for the next strong station and play that for five seconds. When it plays a station that you want to continue listening to, press the SCAN button again.

Preset — You can store the frequencies of your favorite radio stations in the six preset buttons. Each button will store one frequency on the AM band, and two frequencies on the FM band.

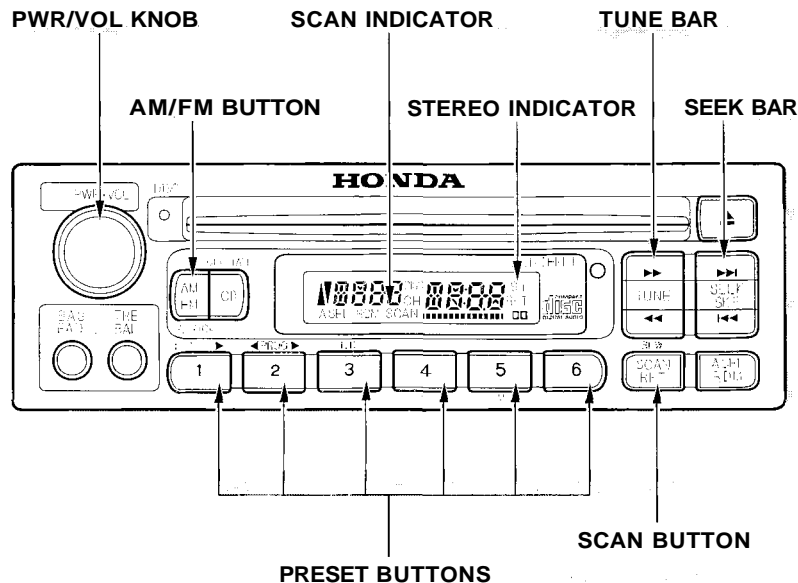

To store a frequency:

1. Select the desired band, AM or FM. FM1 and FM2 let you store two frequencies with each Preset button.
2. Use the TUNE or SEEK function to tune the radio to a desired station.
3. Pick the Preset button you want for that station. Press the button and hold it until you hear a beep.
4. Repeat steps 1 to 3 to store a total of six stations on AM and twelve on FM.

Once a station's frequency is stored, simply press and release the proper Preset button to tune to it.

The preset frequencies will be lost if your vehicle's battery goes dead, is disconnected, or the radio fuse is removed.

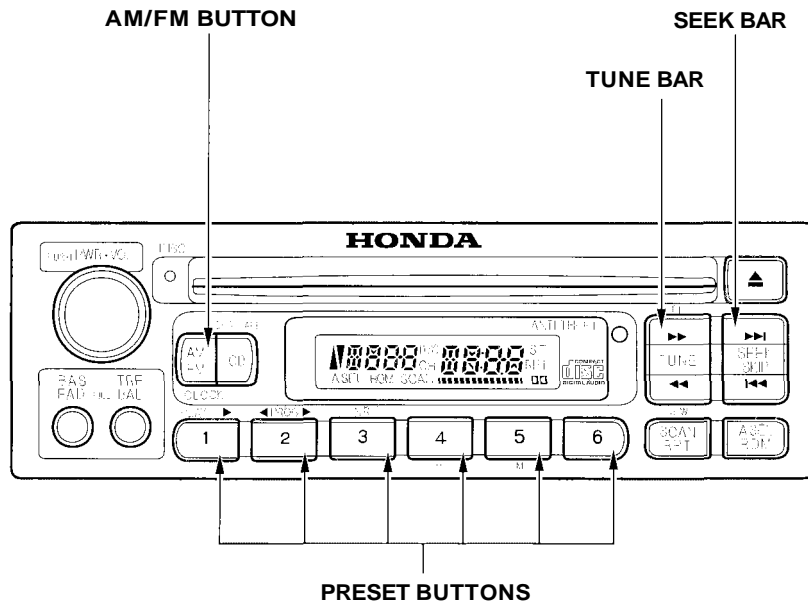

CONTINUED

AUTO SELECT — If you are traveling far from home and can no longer receive the stations you preset, you can use the Auto Select feature to find stations in the local area.

To activate Auto Select, press the A. SEL button. A. SEL will flash in the display, and the system will go into scan mode for several seconds. It automatically scans both bands, looking for stations with strong signals. It stores the frequencies of six AM stations and twelve FM stations in the preset buttons. You can then use the preset buttons to select those stations.

If you are in a remote area, Auto Select may not find six strong AM stations or twelve strong FM stations. If this happens, you will see a "0" displayed when you press any preset button that does not have a station stored.

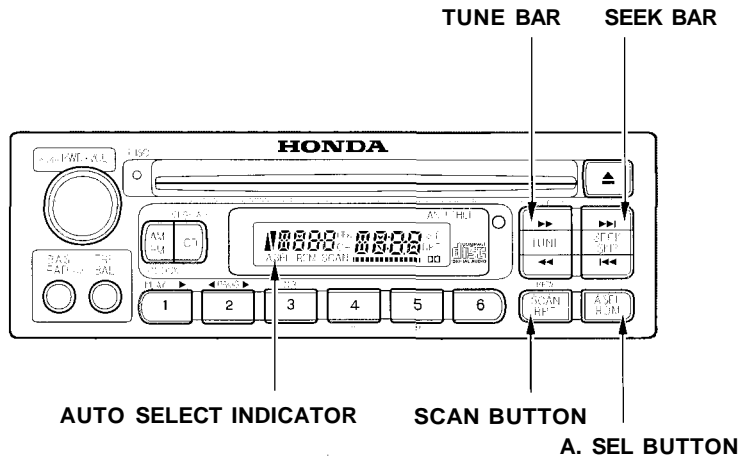

If you do not like the stations Auto Select has stored, you can store other frequencies in the preset buttons. Use the TUNE, SEEK, or SCAN function to find the desired frequencies, then store them in the selected preset buttons as described previously.

Auto Select does not erase the frequencies that you preset previously. When you return home, turn off Auto Select by pressing the A. SEL button. The preset buttons will then select the frequencies you originally set.

Adjusting the Sound

Balance/Fader — These two controls adjust the strength of the sound coming from each speaker. The Balance control adjusts the side-to-side strength, while the Fader control adjusts the front-to-back strength.

To adjust the fader, push on the BASS/FADER control knob to get it to pop out. Pull it out slightly farther, and adjust the front-to-back sound to your liking. Push the knob back in when you are done so you cannot change the setting by accidentally bumping it.

To adjust the balance, push on the TREBLE/BALANCE control knob to get it to pop out. Pull it out slightly farther, and adjust the side-to-side sound to your liking. Push the knob back in when you are done so you cannot change the setting by accidentally bumping it.

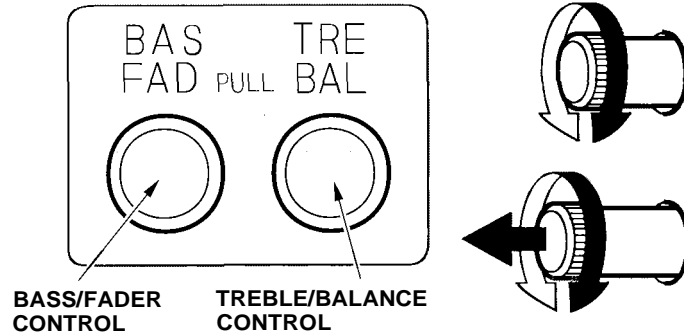

Treble/Bass — Use these controls to adjust the tone to your liking.

To adjust the Treble level, push on the TREBLE/BALANCE control knob to get it to pop out. Without pulling it out farther, turn the knob to adjust the treble level. Push the knob back in when you are done so you cannot change the setting by accidentally bumping it.

To adjust the Bass level, push on the BASS/FADER control knob to get it to pop out. Without pulling it out farther, turn the knob to adjust the bass level. Push the knob back in when you are done so you cannot change the setting by accidentally bumping it.

Digital Clock

The display of your audio system usually shows the time when the ignition switch is in ACCESSORY (I) or ON (II). It shows operation mode of radio, CD player, or optional CD changer when you operate them, and goes back to the time display after five seconds.

The display also goes back to the time display two seconds after you turn the volume knob to adjust the volume.

If an error occurs while operating the CD player or optional CD changer, the display will show the error code and will not switch to the time display until the error is corrected (see pages [111](#) and [112](#)).

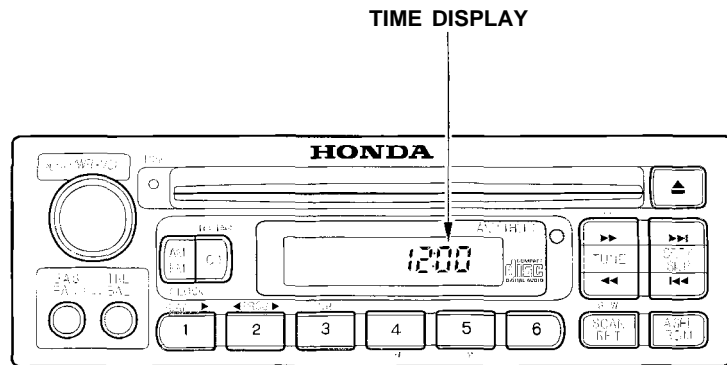

To set the time, press the **CLOCK** (AM/FM) button for more than two seconds until you hear a beep. The time display will begin blinking. To set the hour, press and hold the **H** (Preset 4) button until the hour advances to the desired time.

To set the minutes, press and hold the **M** (Preset 5) button until the numbers advance to the desired time.

When you are finished, press the **CLOCK** button again. The time display will stop blinking and the time is now set.

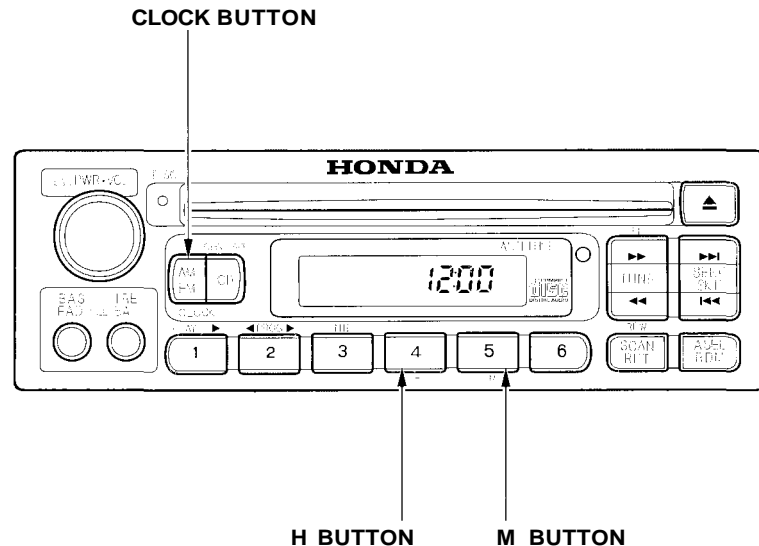

Audio System Lighting

The audio system illuminates when the parking lights are on, even if the radio is turned off.

Radio Frequencies

Your Honda's radio can receive the complete AM and FM bands. Those bands cover these frequencies:

AM band:

530 to 1,710 kilohertz

FM band:

87.7 to 107.9 megahertz

Radio stations on the AM band are assigned frequencies at least ten kilohertz apart (530, 540, 550). Stations on the FM band are assigned frequencies at least 0.2 megahertz apart (87.9, 88.1, 88.3).

Stations must use these exact frequencies. It is fairly common for stations to round-off the frequency in their advertising, so your radio could display a frequency of 100.9 even though the announcer may identify the station as "FM 101."

Radio Reception

How well your Honda's radio receives stations is dependent on many factors, such as the distance from the station's transmitter, nearby large objects, and atmospheric conditions.

A radio station's signal gets weaker as you get farther away from its transmitter. If you are listening to an AM station, you will notice the sound volume becoming weaker, and the station drifting in and out. If you are listening to an FM station, you will see the stereo indicator flickering off and on as the signal weakens. Eventually, the stereo indicator will go off and the sound will fade completely as you get out of range of the station's signal.

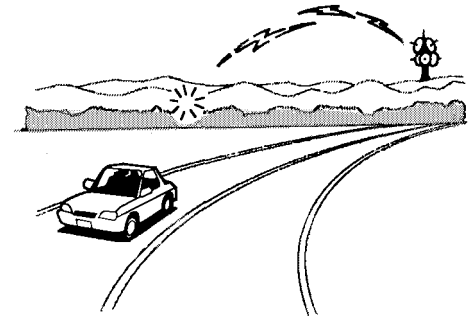

Driving very near the transmitter of a station that is broadcasting on a frequency close to the frequency of the station you are listening to can also affect your radio's reception. You may temporarily hear both stations, or hear only the station you are close to.

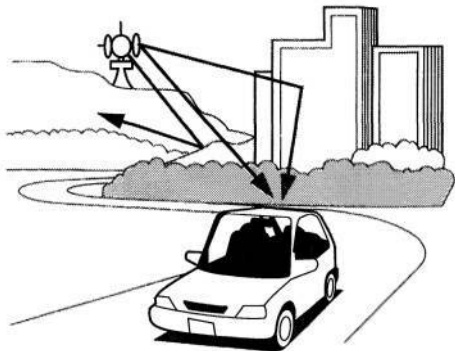

Radio signals, especially on the FM band, are deflected by large objects such as buildings and hills. Your radio then receives both the direct signal from the station's transmitter, and the deflected signal. This causes the sound to distort or flutter. This is a main cause of poor radio reception in city driving.



Radio reception can be affected by atmospheric conditions such as thunderstorms, high humidity, and even sunspots. You may be able to receive a distant radio station one day and not receive it the next day because of a change in conditions.

Electrical interference from passing vehicles and stationary sources can cause temporary reception problems.

*As required by the FCC:
Changes or modifications not expressly approved by the party responsible for compliance could void the user's authority to operate the equipment.*

Operating the CD Player

You operate the CD player with the same controls used for the radio.

With the ignition switch in ACCESSORY (I) or ON (II), insert the disc into the CD slot. Push the disc in halfway, the drive will pull it in the rest of the way and begin to play. The number of the track that is playing is shown in the display.

You can also play 3-inch (8-cm) discs without using an adapter ring. In all cases, play only standard round discs. Odd-shaped CDs may jam in the drive or cause other problems.

Do not play discs with disc accessories such as protective seals or rubbers. Using them may also cause the audio system to malfunction.

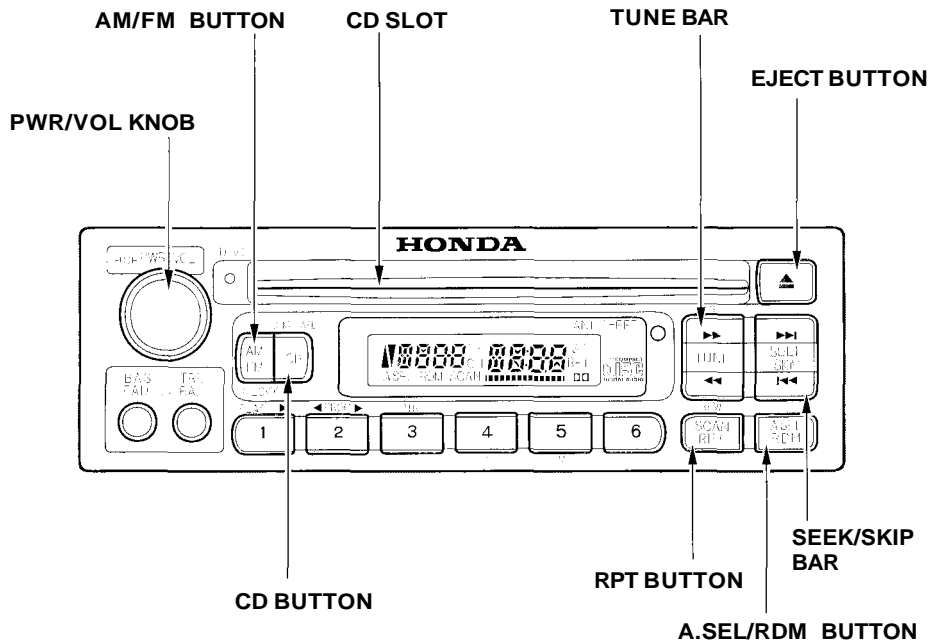

CONTINUED

When the system reaches the end of the disc, it will return to the beginning and play that disc again.



You can switch to the radio while a CD is playing by pressing the AM/FM button. Press the CD button to return to playing the CD. The CD will begin playing where it left off.



If you turn the system off while a CD is playing, either with the PWR/VOL knob or by turning off the ignition, the disc will stay in the drive. When you turn the system back on, the CD will begin playing where it left off.

Press the eject button to remove the disc from the drive.

If you eject the disc, but do not remove it from the slot, the system will automatically reload the disc after 15 seconds and put the CD player in pause mode. To begin playing the disc, press the CD button.

You can use the TUNE and SEEK/SKIP bars while a disc is playing to select passages and change tracks.

To move rapidly within a track, press and hold the TUNE bar. Press the  side to move forward. You will see CUE in the display. Press the  side to move backward. You will see REW displayed. Release the bar when the system reaches the point you want.

Each time you press and release the  side of the SEEK/SKIP bar, the system skips forward to the beginning of the next track. Press the  side to skip backward to the beginning of the current track. Press it again to skip to the beginning of the previous track.

REPEAT — To activate the Repeat feature, press and release the RPT button. You will see RPT in the display. The system continuously replays the current track. Press the RPT button again to turn it off.

RANDOM PLAY — This feature, when activated, plays the tracks on the CD in random order, rather than in the order they are recorded on the CD. To activate Random Play, press and release the A. SEL/RDM button. You will see RDM in the display. The system will then select and play tracks randomly. This continues until you deactivate Random Play by pressing A. SEL/RDM again.

If the system is in Repeat mode, you must turn it off by pressing the RPT button before selecting Random Play.

Operating the CD Changer (Optional)

A Compact Disc changer is available for your vehicle. It holds up to six discs, providing several hours of continuous entertainment. You operate this CD changer with the same controls used for the in-dash CD player.

Load the desired CDs in the magazine and load the magazine in the changer according to the instructions that came with the unit. Play only standard round discs. Odd-shaped CDs may jam in the drive or cause other problems.

Do not play discs with disc accessories such as protective seals or rubbers. Using them may also cause the audio system to malfunction.

To select the CD changer, press the CD button. The disc and track numbers will be displayed.

To select a different disc, press the appropriate preset button (1 — 6). If you select an empty slot in the magazine, the changer will, after finding that slot empty, try to load the CD in the next slot. This continues until it finds a CD to load and play.

If you load a CD in the in-dash player while the changer is playing a CD, the system will stop the changer and begin playing the in-dash CD. To select the changer again, press the CD button. Play will begin where it left off. Use the CD button to switch between the player and the changer.

If you eject the in-dash CD while it is playing, the system will automatically switch to the CD changer and begin play where it left off. If there are no CDs in the changer, the display will flash. You will have to select another mode (AM or FM) with the button.

When you switch back to CD mode, the system selects the same unit (in-dash or changer) that was playing when you switched out of CD mode.

To use the SKIP, REPEAT, and RANDOM functions, refer to the in-dash player operating instructions.

Protecting Compact Discs

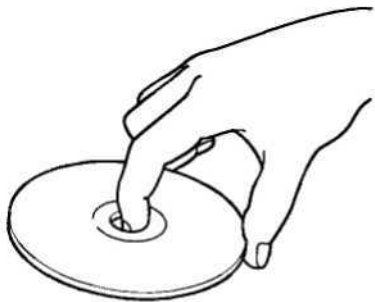

Handle a CD by its edges: never touch either surface. Contamination from fingerprints, liquids, felt-tip pens, and labels can cause the CD to not play properly, or possibly jam in the drive.

When a CD is not being played, store it in its case to protect it from dust and other contamination. To prevent warpage, keep CDs out of direct sunlight and extreme heat.

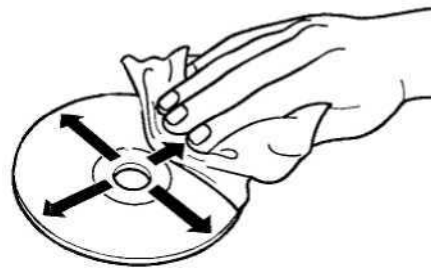

To clean a disc, use a clean soft cloth. Wipe across the disc from the center to the outside edge.

CONTINUED

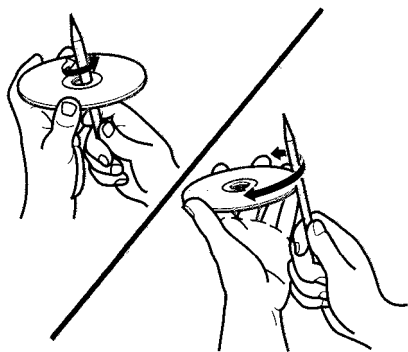

A new CD may be rough on the inner and outer edges. The small plastic pieces causing this roughness can flake off and fall on the recording surface of the disc, causing skipping or other problems. Remove these pieces by rubbing the inner and outer edges with the side of a pencil or pen.

Never try to insert foreign objects in the CD player or the magazine.

CD Player Error Indications

If you see an error indication in the display while operating the CD player, find the cause in the chart to the right. If you cannot clear the error indication, take the vehicle to your Honda dealer.

Indication	Cause	Solution
CD E-00	System Error FOCUS Error	Press the EJECT button and pull out the disc. Check if the disc is inserted correctly in CD player. Make sure the disc is not scratched or damaged.
CD E-01	Mechanical Error	Press the EJECT button and pull out the disc. Check the disc for damage or deformation. If the CD cannot be pulled out or the error indication does not disappear after the disc is ejected, see your Honda dealer. Do not try to force the disc out of the player.
CD E-02	Communication Error LSI Error	Consult your Honda dealer.

CD Changer Error Indications

If you see an error indication in the display while operating the CD changer, find the cause in the chart to the right. If you cannot clear the error indication, take the vehicle to your Honda dealer.

Indication	Cause	Solution
CD 0 ^{err} E-00	System Error FOCUS Error	Press the magazine eject button and pull out the magazine, check for error indication. Insert the magazine again. If the code does not disappear or the magazine cannot be pulled out, consult your Honda dealer.
CD 0 ^{err} E-01	Mechanical Error	Press the magazine eject button and pull out the magazine, check for error indication. Insert the magazine again. If the code does not disappear or the magazine cannot be pulled out, consult your Honda dealer.
CD 0 ^{err} E-02	Communication Error LSI Error	See your Honda dealer.
CD 0 ^{err} ---H	High temperature.	Will disappear when the temperature returns to normal.
CD 0 ^{err} ----	No CD magazine in the CD changer.	Insert CD magazine.
	No CD in the CD magazine.	Insert CD.

Remote Audio Controls

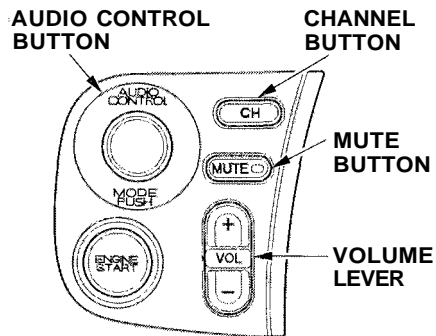

Four controls for the audio system are on the left side of the dashboard by the instrument panel. These let you control basic functions without distracting your attention from driving.

Use the VOLUME lever to adjust the volume. Push the lever up to increase the volume and down to decrease it. Hold the lever until the volume reaches the desired level,

then release it.

If you want to mute the sound temporarily, push the MUTE button. The indicator in the button will light to indicate the mute function is on. Press the button again to cancel MUTE.

The AUDIO CONTROL button changes the mode. Pressing the button repeatedly selects AM, FM1, FM2, or CD (if a CD is loaded) two.

The CHANNEL button has two functions, depending on whether you are listening to the radio, or playing a CD.

If you are listening to the radio, use the CHANNEL button to change stations. Each time you press this button, the system advances to the next preset station on the band you are listening to. You will see the number of the selected Preset button

in the audio system display.

If you are playing a CD, the system skips to the beginning of the next track each time you push the CHANNEL button.

These controls work only with the factory-installed audio system. They will not function if you install any other system.

Theft Protection

Your car's audio system will disable itself if it is disconnected from electrical power for any reason. To make it work again, the user must enter a specific five-digit code in the Preset buttons. Because there are hundreds of number combinations possible from five digits, making the system work without knowing the exact code is nearly impossible.

You should have received a card that lists your audio system's code number and serial number. It is best to store this card in a safe place at home. In addition, you should write the audio system's serial number in this Owner's Manual. If you should happen to lose the card, you must obtain the code number from your Honda dealer. To do this, you will need the system's serial number.

If your car's battery is disconnected or goes dead, or the radio fuse is removed, the audio system will disable itself. If this happens, you will see "Code" in the frequency display the next time you turn on the system. Use the Preset buttons to enter the five-digit code. If it is entered correctly, the radio will start playing.

If you make a mistake entering the code, do not start over or try to correct your mistake. Complete the five-digit sequence, then enter the correct code. You have ten tries to enter the correct code. If you are unsuccessful in ten attempts, you must then leave the system on for one hour before trying again.

You will have to store your favorite stations in the Preset buttons after the system begins working. Your original settings were lost when power was disconnected.

Before you begin driving your Honda, you should know what gasoline to use, and how to check the levels of important fluids. You also need to know how to properly store luggage or packages. The information in this section will help you. If you plan to add any accessories to your vehicle, please read the information in this section first.

Break-in Period.....	116
Gasoline.....	116
Service Station Procedures	117
Filling the Fuel Tank.....	117
Opening the Hood.....	118
Oil Check.....	119
Engine Coolant Check.....	120
Fuel Economy.....	121
Car Condition.....	121
Driving Habits.....	121
Accessories and Modifications....	122
Accessories.....	122
Modifications.....	123
Additional Safety Precaution....	123
Carrying Cargo.....	124
General Precautions.....	127

Break-in Period

Help assure your car's future reliability and performance by paying extra attention to how you drive during the first 600 miles (1,000 km). During this period:

- Avoid full-throttle starts and rapid acceleration.
Do not exceed 5,500 rpm for the first 600 miles (1,000 km) of operation.
- Avoid hard braking. New brakes need to be broken-in by moderate use for the first 200 miles (300 km).
- Do not change the oil until the recommended time or mileage interval shown in the maintenance schedule.

You should follow these same recommendations with an overhauled or exchanged engine, or when the brakes are relined.

Gasoline

Your Honda is designed to operate on premium unleaded gasoline with a pump octane number of 91 or higher.

If you are unable to find premium unleaded gasoline, you may substitute an unleaded regular gasoline. The engine will compensate for the lower octane, but you may notice a slight decrease in power as a result.

We recommend gasolines containing detergent additives that help prevent fuel system and engine deposits.

Using gasoline containing lead will damage your car's emissions controls. This contributes to air pollution.

In Canada, some gasolines contain an octane-enhancing additive called MMT. If you use such gasolines, your emission control system performance may deteriorate and the Malfunction Indicator Lamp on your instrument panel may turn on. If this happens, contact your authorized Honda dealer for service.

Filling the Fuel Tank

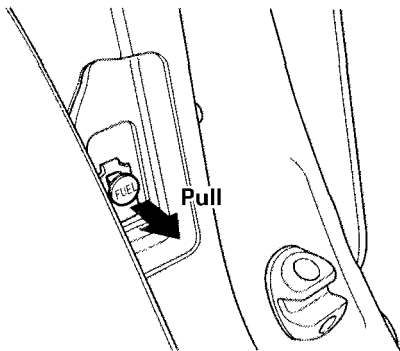

1. Because the fuel fill cap is on the driver's side of the car, park with that side closest to the service station pumps.
2. Open the fuel fill door by pulling on the knob on the driver's door jamb.

Gasoline is highly flammable and explosive. You can be burned or seriously injured when handling fuel.

- Stop the engine and keep heat, sparks, and flame away.
- Handle fuel only outdoors.
- Wipe up spills immediately.

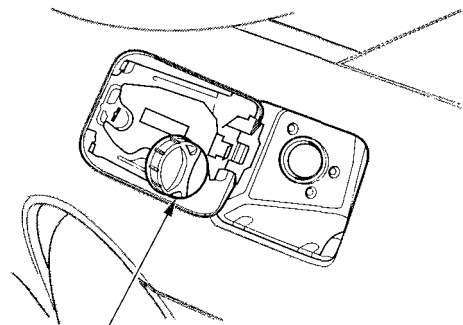

FUEL FILL CAP

3. Remove the fuel fill cap slowly. You may hear a hissing sound as pressure inside the tank escapes. Place the cap in the holder on the fuel fill door.

CONTINUED

4. Stop filling the tank after the fuel nozzle automatically clicks off. Do not try to "top off" the tank, leave some room for the fuel to expand with temperature changes.
5. Screw the fuel fill cap back on, tighten it until it clicks several times. If you do not properly tighten the cap, the Malfunction Indicator Lamp may come on (see page [230](#)).
6. Push the fuel fill door closed until it latches.

Opening the Hood

RELEASE HANDLE

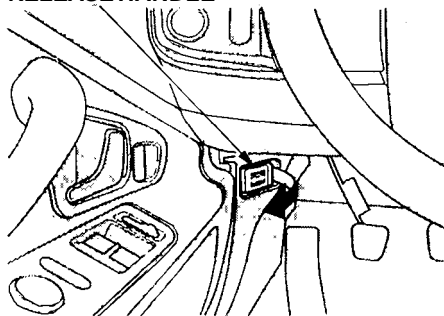

1. Shift to Neutral and set the parking brake. Pull the hood release handle located under the lower left corner of the dashboard. The hood will pop up slightly.
2. Standing in front of the car, put your fingers under the front edge of the hood to the right of center. Slide your hand to the left until you feel the hood latch handle. Push this handle to the left until it

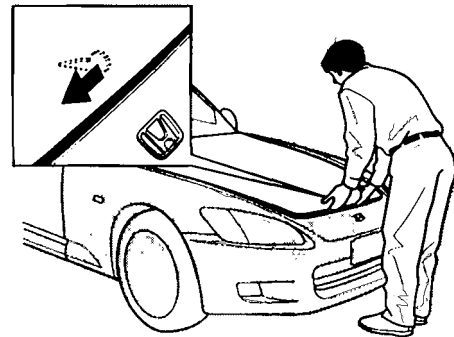

releases the hood. Lift the hood.

If you can open the hood without lifting the hood latch handle, or the hood latch handle moves stiffly or does not spring back as before, the mechanism should be cleaned and lubricated (see page [174](#)).

Oil Check

DIPSTICK

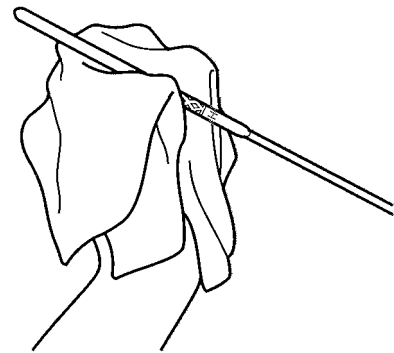
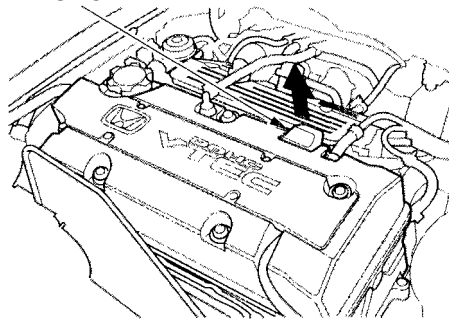

3. Pull the support rod out of its clip and insert the end into the hole on the front of the hood around the center.

To close the hood, lift it up slightly to remove the support rod from the hole. Put the support rod back into its holding clip. Lower the hood to about a foot (30 cm) above the fender, then let it drop. After closing the hood, make sure it is securely latched.

Check the engine oil level every time you fill the car with fuel. Wait a few minutes after turning the engine off before you check the oil.

1. Remove the dipstick (black handle).

2. Wipe the dipstick with a clean cloth or paper towel.

CONTINUED

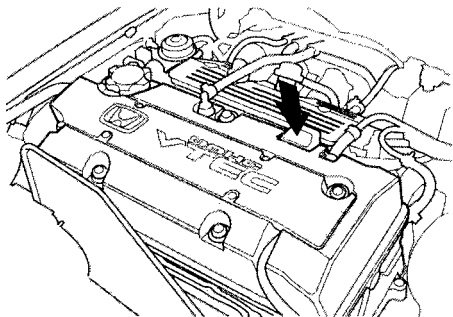

3. Insert it all the way back in its tube.

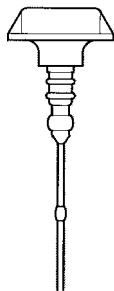

UPPER MARK

LOWER MARK

4. Remove the dipstick again and check the level. It should be between the upper and lower marks.

If it is near or below the lower mark, see **Adding Oil** on page 157.

Engine Coolant Check

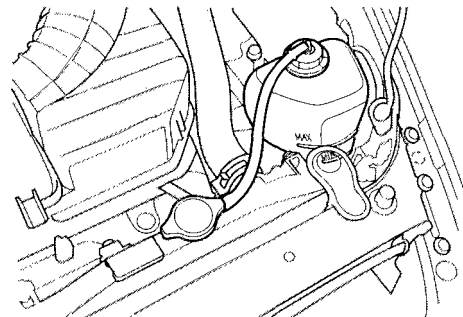

Look at the coolant level in the radiator reserve tank. Make sure it is between the MAX and MIN lines. If it is below the MIN line, see **Adding Engine Coolant** on page 161 for information on adding the proper coolant.

Refer to **Owner Maintenance Checks** on page 155 for information on checking other items in your Honda.

The condition of your car and your driving habits are the two most important things that affect the fuel mileage you get.

Car Condition

Always maintain your car according to the maintenance schedule. This will keep it in top operating condition.

An important part of that maintenance is the **Owner Maintenance Checks** (see page 155). For example, an underinflated tire causes more "rolling resistance," which uses fuel. It also wears out faster, so check the tire pressure at least monthly.

In winter, the build-up of snow on your car's underside adds weight and rolling resistance. Frequent cleaning helps your fuel mileage and reduces the chance of corrosion.

Driving Habits

You can improve fuel economy by driving moderately. Rapid acceleration, abrupt cornering, and hard braking use more fuel.

Always drive in the highest gear that allows the engine to run and accelerate smoothly.

Depending on traffic conditions, try to maintain a constant speed. Every time you slow down and speed up, your car uses extra fuel. Use the cruise control, when appropriate, to increase fuel economy.

A cold engine uses more fuel than a warm engine. It is not necessary to "warm-up" a cold engine by letting it idle for a long time. You can drive away in about a minute, no matter how cold it is outside. The engine will warm up faster, and you get better fuel economy. To cut down on the number of "cold starts," try to

combine several short trips into one.

The air conditioning puts an extra load on the engine which makes it use more fuel. Turn off the A/C to cut down on air conditioning use. Use the flow-through ventilation when the outside air temperature is moderate.

Modifying your car, or installing some non-Honda accessories, can make your car unsafe. Before you make any modifications or add any accessories, be sure to read the following information.

Accessories

Your dealer has Genuine Honda accessories that allow you to personalize your car. These accessories have been designed and approved for your car, and are covered by warranty.

Non-Honda accessories are usually designed for universal applications. Although aftermarket accessories may fit on your car, they may not meet factory specifications, and could adversely affect your car's handling and stability. (See "Modifications" on the page [123](#) for additional information.)

Improper accessories or modifications can affect your car's handling, stability and performance, and cause a crash in which you can be hurt or killed.

Follow all instructions in this owner's manual regarding accessories and modifications.

When properly installed, cellular phones, alarms, two-way radios, and low-powered audio systems should not interfere with your car's computer-controlled systems, such as the SRS and anti-lock brake system.

However, if electronic accessories are improperly installed, or exceed your car's electrical system capacity, they can interfere with the operation of your car, or even cause the airbags to deploy.

Before installing any accessory:

- Make sure the accessory does not obscure any lights, or interfere with proper car operation or performance.
- Be sure electronic accessories do not overload electrical circuits (see page [235](#)).
- Have the installer contact your Honda dealer for assistance before installing any electronic accessory.

If possible, have your dealer inspect the final installation.

Modifications

Do not remove any original equipment or modify your car in any way that would alter its design or operation. This could make your car unsafe and illegal to drive.

For example, do not make any modifications that would change the ride height of your car, or install wheels and tires with a different overall diameter.

Such modifications can adversely affect handling, and interfere with the operation of the car's anti-lock brakes and other systems.

In addition, any modifications that decrease ground clearance increase the chance of undercarriage parts striking a curb, speed bump, or other raised object, which could cause your airbags to deploy.

Do not modify your steering wheel or any other part of your Supplemental Restraint System. Modifications could make the system ineffective.

Additional Safety Precaution

Do not attach or place objects on the airbag covers. Any object attached to or placed on the covers marked "SRS AIRBAG," in the center of the steering wheel and on top of the dashboard, could interfere with the proper operation of the airbags. Or, if the airbags inflate, the objects could be propelled inside the car and hurt someone.

Carrying Cargo

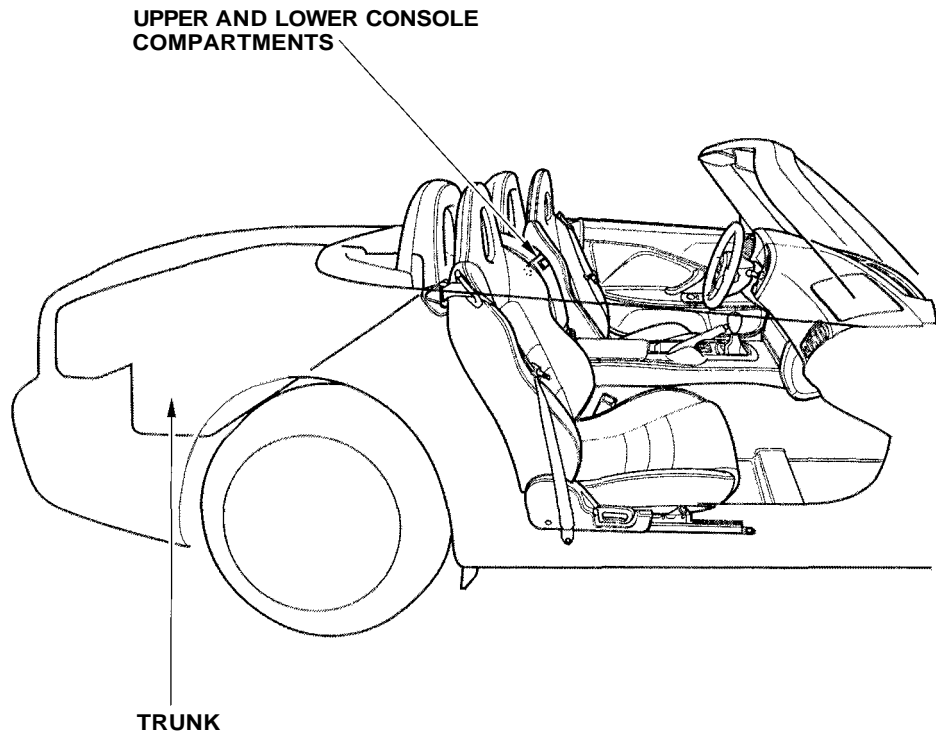

Your car has several convenient storage areas so you can stow cargo safely.

The upper and lower console compartments are designed for small, lightweight items. The trunk is intended for larger, heavier items.

However, carrying too much cargo, or improperly storing it, can affect your car's handling, stability and operation and make it unsafe. Before carrying any type of cargo, be sure to read the following pages.

Load Limit

The maximum load for your car is 400 lbs (185kg).

This figure includes the total weight of all occupants, cargo, and accessories.

To figure out how much cargo you can carry:

- Add up the weight of all occupants.
- Subtract the total from 400 lb (185 kg).

The final number is the total weight of cargo you can carry.

Overloading or improper loading can affect handling and stability and cause a crash in which you can be hurt or killed.

Follow all load limits and other loading guidelines in this manual.

Carrying Items in the Passenger Compartment

- Store or secure all items that could be thrown around and hurt someone during a crash.
- Be sure items placed on the floor behind the front seats cannot roll under the seats and interfere with the driver's ability to operate the pedals, or with the proper operation of the seats.

Carrying Cargo

Carrying Cargo in the Trunk

- Distribute cargo evenly on the floor of the trunk, placing the heaviest items on the bottom and as far forward as possible.

Your Honda is designed to give you optimum handling and performance on well-maintained roads. As part of this design, your car has a minimum of ground clearance and very low-profile tires.

- Use caution if you should drive your car on very rough or rutted roads. You could damage the suspension and underbody by bottoming out. Going too fast over parking lot "speed bumps" can also cause damage.

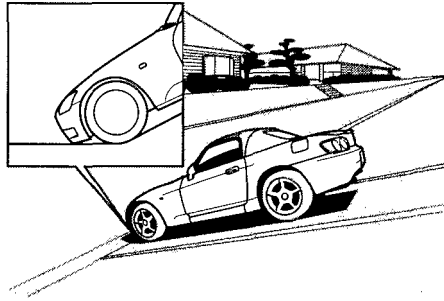

- Curbs and steep inclines could damage the front and rear bumpers. Low curbs that do not affect the average car may be high enough to hit the bumper on your Honda. The front or rear bumper may scrape when trying to drive onto an incline, such as a steep driveway or trailer ramps.

- Because of the low-profile tires fitted to your car, the alloy wheels are closer to the ground. Driving over a pothole or road debris at too high a speed can seriously damage a wheel. Slow down under these conditions.

This section gives you tips on starting the engine under various conditions, and how to operate the manual transmission. It also includes important information on parking your car, and the braking system.

Preparing to Drive.....	130
Starting the Engine.....	131
Starting in Cold Weather at High Altitude	132
6-speed Manual Transmission....	133
Recommended Shift Points.....	134
Engine Speed Limiter	134
Reverse Lockout.....	134
Parking.....	135
The Braking System.....	136
Brake Wear Indicators.....	136
Brake System Design.....	137
Anti-lock Brakes.....	137
Important Safety Reminders.....	138
ABS Indicator.....	139
Driving in Bad Weather.....	140
Towing a Trailer.....	141

Preparing to Drive

You should do the following checks and adjustments every day before you drive your car.

1. Make sure all windows, mirrors, and outside lights are clean and unobstructed. Remove frost, snow, or ice.
2. Check that the hood and trunk are fully closed.
3. Visually check the tires. If a tire looks low, use a gauge to check its pressure.
4. Check that any items you may be carrying with you inside are stored properly or fastened down securely.
5. Check the adjustment of the seat (see page 69).
6. Check the adjustment of the inside and outside mirrors (see page 80).
7. Make sure the doors are securely closed and locked.
8. Fasten your seat belt. Check that your passenger has fastened his seat belt (see page 15).
9. Turn the ignition switch ON (II). Check the indicator lights in the instrument panel.
10. Start the engine (see page 131).
11. Check the gauges and indicator lights in the instrument panel (see page 43).

1. Apply the parking brake.
2. In cold weather, turn off all electrical accessories to reduce the drain on the battery.
3. Push the clutch pedal down all the way. The ENGINE START button has no effect unless the clutch pedal is depressed.
4. Turn the ignition key to ON (II) position.

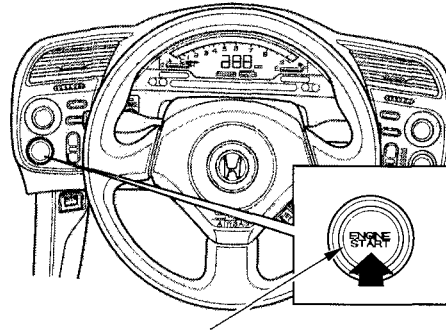

ENGINE START BUTTON

5. Without touching the accelerator pedal, push the ENGINE START button. If the engine does not start right away, do not hold the ENGINE START button for more than 15 seconds at a time. Pause for at least 10 seconds before trying again.

6. If the engine does not start within 15 seconds, or starts but stalls right away, repeat step 5 with the accelerator pedal pressed half-way down. If the engine starts, release pressure on the accelerator pedal so the engine does not race.
7. If the engine still does not start, press the accelerator pedal all the way down and hold it there while starting in order to clear flooding. As before, hold the ENGINE START button for no more than 15 seconds. Return to step 6 if the engine does not start. If it starts, lift your foot off the accelerator pedal so the engine does not race.

Starting the Engine

Starting in Cold Weather at High Altitude (Above 8,000 feet/ 2,400 meters)

An engine is harder to start in cold weather. The thinner air found at high altitude above 8,000 feet (2,400 meters) adds to the problem.

Use the following procedure:

1. Turn off all electrical accessories to reduce the drain on the battery.
2. Push the accelerator pedal half-way to the floor and hold it there while starting the engine. Do not hold the ENGINE START button for more than 15 seconds. When the engine starts, release the accelerator pedal gradually as the engine speeds up and smooths out.
3. If the engine fails to start in step 2, push the accelerator pedal to the floor and hold it there while you try to start the engine for no more than 15 seconds. If the engine does not start, return to step 2.

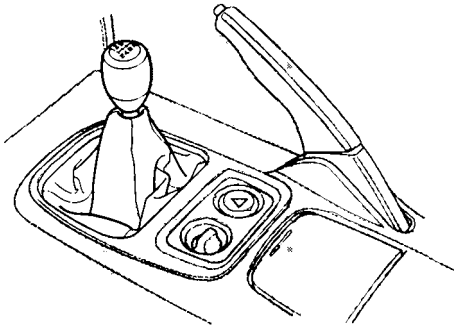

The manual transmission is synchronized in all forward gears for smooth operation. It has a lockout so you cannot shift directly from Fifth to Reverse instead of sixth (see page 134). When shifting up or down, make sure you push the clutch pedal down all the way, shift to the next gear, and let the pedal up gradually. When you are not shifting, do not rest your foot on the clutch pedal. This can cause your clutch to wear out faster.

Come to a full stop before you shift into Reverse. You can damage the transmission by trying to shift into Reverse with the car moving. Push down the clutch pedal, and pause for a few seconds before shifting into Reverse, or shift into one of the forward gears for a moment. This stops the gears so they won't "grind."

When slowing down, you can get extra braking from the engine by shifting to a lower gear. This extra braking can help you maintain a safe speed and prevent your brakes from overheating while going down a steep hill. Before downshifting, make sure engine speed will not go into the tachometer's red zone in the lower gear.

Rapid slowing or speeding-up can cause loss of control on slippery surfaces. If you crash, you can be injured.

Use extra care when driving on slippery surfaces.

6-speed Manual Transmission

Recommended Shift Points

Drive in the highest gear that lets the engine run and accelerate smoothly. This will give you the best fuel economy and effective emissions control. The following shift points are recommended:

Shift Up	Normal Acceleration
1st to 2nd	15 mph (24 km/h)
2nd to 3rd	25 mph (40 km/h)
3rd to 4th	40 mph (64 km/h)
4th to 5th	47 mph (75 km/h)
5th to 6th	52 mph (83 km/h)

Engine Speed Limiter

If you exceed the maximum speed for the gear you are in, the engine speed will enter into the tachometer's red zone. If this occurs, you may feel the engine cut in and out. This is caused by a limiter in the engine's computer controls. The engine will run normally when you reduce the RPM below the red zone.

Before downshifting, make sure the engine will not go into the tachometer's red zone.

Reverse Lockout

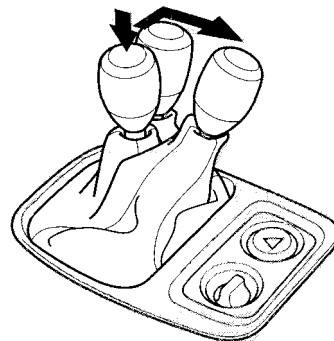

The 6-speed manual transmission has a lockout so you cannot accidentally shift from Fifth to Reverse instead of Sixth.

With the clutch pedal depressed, move the shift lever to the Reverse side of the Neutral gate. Then push the shift lever down and shift to Reverse.

Always use the parking brake when you park your car. The indicator on the instrument panel shows that the parking brake is not fully released; it does not indicate that the parking brake is firmly set. Make sure the parking brake is set firmly or your car may roll if it is parked on an incline.

If the car is facing uphill, turn the front wheels away from the curb and put the transmission in first gear. If the car is facing downhill, turn the front wheels toward the curb and put the transmission in reverse gear.

Make sure the parking brake is fully released before driving away. Driving with the parking brake partially set can overheat or damage the rear brakes.

Parking Tips

- Make sure the convertible top and the windows are closed.
- Turn off the lights.
- Place any packages, valuables, etc., in the trunk or take them with you.
- Lock the doors with the key or the remote transmitter.
- Never park over dry leaves, tall grass, or other flammable materials. The three way catalytic converter gets very hot, and could cause these materials to catch on fire.

Your Honda is equipped with disc brakes at all four wheels. A power assist helps reduce the effort needed on the brake pedal. The ABS helps you retain steering control when braking very hard.

Put your foot on the brake pedal only when you intend to brake. Resting your foot on the pedal keeps the brakes applied lightly, causing them to build up heat. Heat build-up can reduce how well your brakes work. It also keeps your brake lights on all the time, confusing drivers behind you.

Constant application of the brakes when going down a long hill builds up heat and reduces their effectiveness. Use the engine to assist the brakes by downshifting to a lower gear and taking your foot off the accelerator pedal.

Check your brakes after driving through deep water. Apply the brakes moderately to see if they feel normal. If not, apply them gently and frequently until they do. Since a longer distance is needed to stop with wet brakes, be extra cautious and alert in your driving.

Brake Wear Indicators

All four brakes have audible brake wear indicators. When the brake pads need replacing, you will hear a distinctive metallic "screeching" sound when you apply the brakes. If you do not have the brake pads replaced, they will begin screeching all the time.

Your brakes may sometimes squeal or squeak when you apply them lightly. Do not confuse this with the brake wear indicators. They make a very audible "screeching."

Brake System Design

The hydraulic system that operates the brakes has two separate circuits. Each circuit works diagonally across the car (the left-front brake is connected with the right-rear brake, etc.). If one circuit should develop a problem, you will still have braking at two wheels.

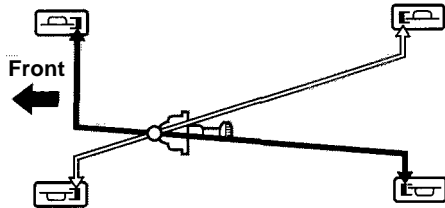

Anti-lock Brakes

Your car has an Anti-lock Brake System (ABS) as standard equipment. ABS helps to prevent the wheels from locking up and skidding during hard braking, allowing you to retain steering control.

When the front tires skid, you lose steering control; the car continues straight ahead even though you turn the steering wheel. The ABS helps to prevent lock-up and helps you retain steering control by pumping the brakes rapidly; much faster than a person can do it.

CONTINUED

You should never pump the brake pedal, this defeats the purpose of the ABS. Let the ABS work for you by always keeping firm, steady pressure on the brake pedal as you steer away from the hazard. This is sometimes referred to as "*stomp and steer.*"

You will feel a pulsation in the brake pedal when the ABS activates, and you may hear some noise. This is normal, it is the ABS rapidly pumping the brakes.

Activation varies with the amount of traction your tires have. On dry pavement, you will need to press on the brake pedal very hard before you activate the ABS. However, you may feel the ABS activate immediately if you are trying to stop on snow or ice.

Important Safety Reminders
ABS does not reduce the time or distance it takes to stop the car, it only helps with steering control during braking. You should always maintain a safe following distance from other vehicles.

ABS will not prevent a skid that results from changing direction abruptly, such as trying to take a corner too fast or making a sudden lane change. Always drive at a safe, prudent speed for the road and weather conditions.

ABS cannot prevent a loss of stability. Always steer moderately when you are braking hard. Severe or sharp steering wheel movement can still cause your car to veer into oncoming traffic or off the road.

A car with ABS may require a longer distance to stop on loose or uneven surfaces, such as gravel or snow, than a car without anti-lock. Slow down and allow a greater distance between cars under those conditions.

ABS Indicator

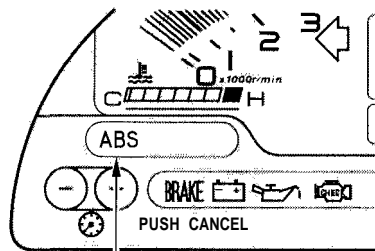

ANTI-LOCK BRAKE SYSTEM INDICATOR*

* U.S. indicator shown

The ABS is self-checking. If anything goes wrong, the ABS indicator on the instrument panel comes on (see page 45). This means the anti-lock function of the braking system has shut down. The brakes still work like a conventional system without anti-lock, providing normal stopping ability. You should have the dealer inspect your car as soon as possible.

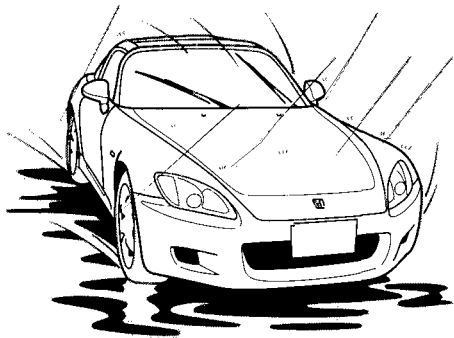

Rain, fog, and snow conditions require a different driving technique because of reduced traction and visibility. Keep your car well-maintained and exercise greater caution when you need to drive in bad weather. The cruise control should not be used in these conditions.

Driving Technique — Always drive slower than you would in dry weather. It takes your car longer to react, even in conditions that may seem just barely damp. Apply smooth, even pressure to all the controls. Abrupt steering wheel movements or sudden, hard application of the brakes can cause loss of control in wet weather. Be extra cautious for the first few miles (kilometers) of driving while you adjust to the change in driving conditions. This is especially true in snow. A person can forget some snow-driving techniques during the summer months. Practice is needed to relearn those skills.

Exercise extra caution when driving in rain after a long dry spell. After months of dry weather, the first rains bring oil to the surface of the roadway, making it slippery.

Visibility — Being able to see clearly in all directions and being visible to other drivers are important in all weather conditions. This is more difficult in bad weather. To be seen more clearly during daylight hours, turn on your headlights.

Inspect your windshield wipers and washers frequently. Keep the windshield washer reservoir full of the proper fluid. Have the windshield wiper blades replaced if they start to streak the windshield or leave parts unwiped. Use the defrosters and air conditioning to keep the windows from fogging up on the inside (see page 91).

Traction — Check your tires frequently for wear and proper pressure. Both are important in preventing "hydroplaning" (loss of traction on a wet surface). In the winter, mount snow tires on all four wheels for the best handling.

Watch road conditions carefully, they can change from moment to moment. Wet leaves can be as slippery as ice. "Clear" roads can have patches of ice. Driving conditions can be very hazardous when the outside temperature is near freezing. The road surface can become covered with areas of water puddles mixed with areas of ice, so your traction can change without warning.

Be careful when downshifting. If traction is low, you can lock up the drive wheels for a moment and cause a skid.

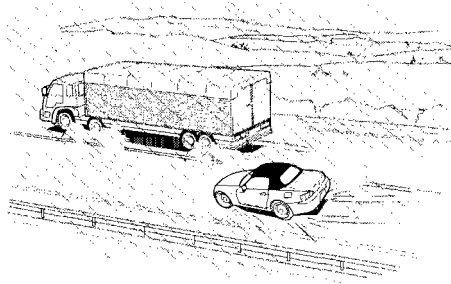

Be very cautious when passing, or being passed by other cars. The spray from large cars reduces your visibility, and the wind buffeting can cause you to lose control.

Towing a Trailer

Your car is not designed to tow a trailer. Attempting to do so can void your warranties.

This section explains why it is important to keep your car well maintained and to follow basic maintenance safety precautions.

This section also includes Maintenance Schedules for normal driving and severe driving conditions, a Maintenance Record, and instructions for simple maintenance tasks you may want to take care of yourself.

If you have the skills and tools to perform more complex maintenance tasks on your Honda, you may want to purchase the Service Manual. See page 263 for information on how to obtain a copy, or see your Honda dealer.

Maintenance Safety.....	144	Spark Plugs.....	174
Important Safety Precautions..	145	Replacement.....	174
Maintenance Schedule.....	146	Specifications.....	176
Required Maintenance Record....	153	Battery.....	177
Owner Maintenance Checks.....	155	Wiper Blades.....	180
Fluid Locations.....	156	Air Conditioning System.....	182
Engine Oil.....	157	Air Conditioning Filter.....	183
Adding Oil.....	157	Drive Belt.....	184
Recommended Oil.....	157	Tires.....	185
Synthetic Oil.....	158	Inflation.....	185
Additives.....	158	Inspection.....	187
Changing the Oil and Filter.....	159	Maintenance.....	188
Cooling System.....	161	Tire Rotation.....	188
Adding Engine Coolant.....	161	Tire Wear.....	188
Replacing Engine Coolant.....	163	Replacing Tires and Wheels	189
Windshield Washers.....	167	Wheels and Tires.....	190
6-speed Manual Transmission		Winter Driving.....	190
Fluid.....	168	Snow Tires.....	191
Differential Fluid.....	169	Tire Chains.....	191
Brake and Clutch Fluid.....	170	Lights.....	192
Brake Fluid.....	170	Replacing Bulbs.....	194
Brake System.....	170	Storing Your Car.....	202
Clutch System.....	171		
Air Cleaner Element.....	172		
Hood Latch.....	174		

Maintenance Safety

Regularly maintaining your car is the best way to protect your investment. Proper maintenance is essential to your safety and the safety of your passengers. It will also reward you with more economical, trouble-free driving and help reduce air pollution.

Improperly maintaining this car or failing to correct a problem before driving can cause a crash in which you can be seriously hurt or killed.

Always follow the inspection and maintenance recommendations and schedules in this owner's manual.

This section includes instructions for simple maintenance tasks, such as checking and adding oil. Any service items not detailed in this section should be performed by a Honda technician or other qualified mechanic.

Some of the most important safety precautions are given here. However, we cannot warn you of every conceivable hazard that can arise in performing maintenance. Only you can decide whether or not you should perform a given task.

Failure to properly follow maintenance instructions and precautions can cause you to be seriously hurt or killed.

Always follow the procedures and precautions in this owner's manual.

Important Safety Precautions

Before you begin any maintenance, make sure your car is parked on level ground and that the parking brake is set. Also, be sure the engine is off. This will help to eliminate several potential hazards:

- **Carbon monoxide poisoning from engine exhaust.** Be sure there is adequate ventilation whenever you operate the engine.
- **Burns from hot parts.** Let the engine and exhaust system cool before touching any parts.
- **Injury from moving parts.** Do not run the engine unless instructed to do so.

Read the instructions before you begin, and make sure you have the tools and skills required.

To reduce the possibility of fire or explosion, be careful when working around gasoline or batteries. Use a commercially available degreaser or parts cleaner, not gasoline, to clean parts. Keep cigarettes, sparks, and flames away from the battery and all fuel-related parts.

You should wear eye protection and protective clothing when working near the battery or when using compressed air.

The Maintenance Schedule specifies how often you should have your car serviced and what things need attention. It is essential that you have your car serviced as scheduled to retain its high level of safety, dependability, and emissions control performance.

The services and time or distance intervals shown in the maintenance schedule assume you will use your car as normal transportation for your passenger and possessions. You should also follow these recommendations:

- Avoid exceeding your car's load limit. This puts excess stress on the engine, brakes, and many other parts of your car. The load limit is shown on the label on the driver's doorjamb.
- Operate your car on reasonable roads within the legal speed limit.
- Drive your car regularly over a distance of several miles (kilometers).
- Always use unleaded gasoline with the proper octane rating (see page [116](#)).

Which Schedule to Follow:

Service your car according to the time and mileage periods on one of the Maintenance Schedules on the following pages. Select the schedule for "Severe Conditions" if most of your driving is done under one or more of the conditions listed on that page. Otherwise, follow the schedule for "Normal Conditions."

Your authorized Honda dealer knows your car best and can provide competent, efficient service. However, service at a dealer is not mandatory to keep your warranties in effect. Maintenance may be done by any qualified service facility or person who is skilled in this type of automotive service. Keep all the receipts as proof of completion, and have the person who does the work fill out the Maintenance Record. Check your warranty booklet for more information.

We recommend the use of genuine Honda parts and fluids whenever you have maintenance done. These are manufactured to the same high-quality standards as the original components, so you can be confident of their performance and durability.

U.S. Cars:

Maintenance, replacement or repair of emissions control devices and systems may be done by any automotive repair establishment or individual using parts that are "certified" to EPA standards.

According to state and federal regulations, failure to perform maintenance on the items marked with # will not void your emissions warranties. However, Honda recommends that all maintenance services be performed at the recommended time or mileage period to ensure long-term reliability.

Service at the indicated distance or time – whichever comes first.	miles x 1,000	15	30	45	60	75	90	105	120	
	km x 1,000	24	48	72	96	120	144	168	192	
	months	12	24	36	48	60	72	84	96	
Replace engine oil	Replace every 7,500 miles (12,000 km) or 12 months									
Replace engine oil filter		•	•	•	•	•	•	•	•	
Check engine oil and coolant	Check oil and coolant at each fuel stop									
Replace air cleaner element			•		•		•		•	
Inspect valve clearance	Adjust only if noisy								•	
Replace spark plugs								•		
Inspect drive belt		•			•		•		•	
Inspect idle speed								•		
Replace engine coolant	120,000 miles (192,000 km) or 120 months, thereafter every 60,000 miles (96,000 km) or 60 months									
Replace transmission fluid									•	
Replace rear differential fluid			•		•		•		•	
Inspect front and rear brakes	•	•	•	•	•	•	•	•	•	
Replace brake fluid	Every 36 months (independent of mileage)									
Check parking brake adjustment	•	•	•	•	•	•	•	•	•	
Replace air conditioning filter			•		•		•		•	
Check tire inflation and condition	Every 7,500 miles (12,000 km)									
Visually inspect the following items:										
Tie rod ends, steering gear box, and boots										
Suspension components										
Driveshaft boots										
Brake hoses and lines (including ABS)	•	•	•	•	•	•	•	•	•	
All fluid levels and condition of fluids										
Cooling system hoses and connections										
Exhaust system [†]										
Fuel lines and connections [‡]										

U.S. Owners

Follow the Normal Conditions Maintenance Schedule if the severe driving conditions specified in the Severe Conditions Maintenance Schedule do not apply.

NOTE: If you only *OCCASIONALLY* drive under a "severe" condition, you should follow the Normal Conditions Maintenance Schedule.

Canadian Owners

Follow the Maintenance Schedule for Severe Conditions.

: See information on maintenance and emissions warranty, last column, page 147.

Service at the indicated distance or time, whichever comes first. Do the items in **A, B, C, D** as required for each distance/time interval.

U.S. Owners — Refer to page 148 to determine which schedule to use.

Canadian owners: Follow the schedule for Severe Conditions.

7,500 mi/12,000 km	Do items in A.
15,000 mi/24,000 km/1 yr	Do items in A, B.
22,500 mi/36,000 km	Do items in A.
30,000 mi/48,000 km/2 yrs	Do items in A, B, C.
37,500 mi/60,000 km	Do items in A.
45,000 mi/72,000 km/3 yrs	Do items in A, B, D.
52,500 mi/84,000 km	Do items in A.
60,000 mi/96,000 km/4 yrs	Do items in A, B, C.
67,500 mi/108,000 km	Do items in A.
75,000 mi/120,000 km/5 yrs	Do items in A, B.
82,500 mi/132,000 km	Do items in A.
90,000 mi/144,000 km/6 yrs	Do items in A, B, C, D.
97,500 mi/156,000 km	Do items in A.
105,000 mi/168,000 km/7 yrs	<input type="checkbox"/> Inspect valve clearance. <input type="checkbox"/> Check idle speed. <input type="checkbox"/> Replace spark plugs. Do items in A, B.
112,500 mi/180,000 km	Do items in A.
120,000 mi/192,000 km/10 yrs	<input type="checkbox"/> Replace engine coolant, thereafter replace every 60,000 mi/96,000 km/5 yrs.
120,000 mi/192,000 km/8 yrs	<input type="checkbox"/> Replace transmission fluid. Do items in A, B, C.

A	<input type="checkbox"/> Replace engine oil. <input type="checkbox"/> Check tire inflation and condition.
B	<input type="checkbox"/> Replace engine oil filter. <input type="checkbox"/> Inspect front and rear brakes. <input type="checkbox"/> Check parking brake adjustment. <input type="checkbox"/> Inspect tie rod ends, steering gear box and boots. <input type="checkbox"/> Inspect suspension components. <input type="checkbox"/> Inspect driveshaft boots. <input type="checkbox"/> Inspect brake hoses and lines (including ABS). <input type="checkbox"/> Check all fluid levels, condition of fluids, and check for leaks. <input type="checkbox"/> Inspect cooling system hoses and connections. <input type="checkbox"/> * Inspect exhaust system. <input type="checkbox"/> # Inspect fuel lines and connections.
C	<input type="checkbox"/> Replace air cleaner element. <input type="checkbox"/> Replace rear differential fluid. <input type="checkbox"/> Replace air conditioning filter. <input type="checkbox"/> Inspect drive belt.
D	<input type="checkbox"/> Replace brake fluid every 3 years (independent of mileage).

: See information on maintenance and emissions warranty, last column, page 147.

Note:

- Check engine oil and coolant at each fuel stop.
- Check and adjust valve clearance, cold engine, only if noisy.

Service at the indicated distance or time – whichever comes first.	miles x 1,000	15	30	45	60	75	90	105	120
	km x 1,000	24	48	72	96	120	144	168	192
	months	12	24	36	48	60	72	84	96
Replace engine oil and oil filter	Replace every 3,750 miles (6,000 km) or 6 months								
Check engine oil and coolant	Check oil and coolant at each fuel stop								
Replace air cleaner element	•	•	•	•	•	•	•	•	•
Use normal schedule except in dusty conditions									
Inspect valve clearance	Adjust only if noisy								•
Replace spark plugs								•	
Inspect drive belt		•			•		•		•
Inspect idle speed								•	
Replace engine coolant	120,000 miles (192,000 km) or 120 months, thereafter every 60,000 miles (96,000 km) or 60 months								
Replace transmission fluid					•				•
Replace rear differential fluid	•	•	•	•	•	•	•	•	•
Inspect front and rear brakes	Inspect every 7,500 miles (12,000 km) or 6 months								
Replace brake fluid	Every 36 months (independent of mileage)								
Check parking brake adjustment	•	•	•	•	•	•	•	•	•
Replace air conditioning filter ^(*)			•		•		•		•
Lubricate all hinges, locks and latches	•	•	•	•	•	•	•	•	•
Check tire inflation and condition	Every 7,500 miles (12,000 km)								
Visually inspect the following items:									
Tie rod ends, steering gear box, and boots	Every 7,500 miles (12,000 km) or 6 months								
Suspension components, Driveshaft boots									
Brake hoses and lines (including ABS)									
All fluid levels and condition of fluids									
Cooling system hoses and connections	•	•	•	•	•	•	•	•	•
Exhaust system [†] , Fuel lines and connections [†]									
Lights and controls, Vehicle underbody									

*1 : Refer to page 183 for replacement information under special driving conditions.

U.S. Owners

Follow the Severe Conditions Maintenance Schedule if you drive your vehicle **MAINLY** under one or more of the following conditions:

- Driving less than 5 miles (8 km) per trip or, in freezing temperatures, driving less than 10 miles (16 km) per trip.
- Driving in extremely hot [over 90°F (32° Q)] conditions.
- Extensive idling or long periods of stop-and-go driving.
- Driving in mountainous conditions.
- Driving on muddy, dusty, or de-iced roads.

Canadian Owners

Follow the Maintenance Schedule for Severe Conditions.

#: See information on maintenance and emissions warranty, last column, page 147.

Service at the indicated distance or time, whichever comes first. Do the items in **A, B, C, D, E, F** as required for each distance/time.

U.S. Owners — Refer to page 150 to determine which schedule to use.

Canadian Owners — Use the Maintenance Schedule for Severe Conditions.

3,750 mi/6,000 km	Do items in A.
7,500 mi/12,000 km	Do items in A, B.
11,250 mi/18,000 km	Do items in A.
15,000 mi/24,000 km/1 yr	Do items in A, B, C.
18,750 mi/30,000 km	Do items in A.
22,500 mi/36,000 km	Do items in A, B.
26,250 mi/42,000 km	Do items in A.
30,000 mi/48,000 km/2 yrs	Do items in A, B, C, D.
33,750 mi/54,000 km	Do items in A.
37,500 mi/60,000 km	Do items in A, B.
41,250 mi/66,000 km	Do items in A.
45,000 mi/72,000 km/3 yrs	Do items in A, B, C, E.
48,750 mi/78,000 km	Do items in A.
52,500 mi/84,000 km	Do items in A, B.
56,250 mi/90,000 km	Do items in A.
60,000 mi/96,000 km/4 yrs	Do items in A, B, C, D, F.
63,750 mi/102,000 km	Do items in A.
67,500 mi/108,000 km	Do items in A, B.
71,250 mi/114,000 km	Do items in A.
75,000 mi/120,000 km/5 yrs	Do items in A, B, C.
78,750 mi/126,000 km	Do items in A.

*1 : See Air Conditioning Filter on page 183 for replacement information under special driving conditions.

: See information on maintenance and emissions warranty, last column, page 147.

Note:

- Check engine oil and coolant at each fuel stop.
- Check and adjust valve clearance, cold engine, only if noisy.

A	<input type="checkbox"/> Replace engine oil and filter.
B	<input type="checkbox"/> Inspect front and rear brakes. <input type="checkbox"/> Check tire inflation and condition. <input type="checkbox"/> Inspect tie rod ends, steering gear box and boots. <input type="checkbox"/> Inspect suspension components. <input type="checkbox"/> Inspect driveshaft boots.
C	<input type="checkbox"/> Replace air cleaner element. <input type="checkbox"/> Check parking brake adjustment. <input type="checkbox"/> Lubricate all hinges, locks and latches with multipurpose grease. <input type="checkbox"/> Replace rear differential fluid. <input type="checkbox"/> Inspect brake hoses and lines (including ABS). <input type="checkbox"/> Check all fluid levels, condition of fluids, and check for leaks. <input type="checkbox"/> Inspect cooling system hoses and connections. <input type="checkbox"/> * Inspect exhaust system. <input type="checkbox"/> * Inspect fuel lines and connections. <input type="checkbox"/> Check all lights. <input type="checkbox"/> Inspect the underbody.
D	<input type="checkbox"/> Inspect drive belt. <input type="checkbox"/> Replace air conditioning filter*1.
E	<input type="checkbox"/> Replace Brake fluid every 3 years (independent of mileage).
F	<input type="checkbox"/> Replace transmission fluid.

CONTINUED

82,500 mi/132,000 km	Do items in A, B.
86,250 mi/138,000 km	Do items in A.
90,000 mi/144,000 km/6 yrs	Do items in A, B, C, D, E.
93,750 mi/150,000 km	Do items in A.
97,500 mi/156,000 km	Do items in A, B.
101,250 mi/162,000 km	Do items in A.
105,000 mi/168,000 km/7 yrs	<input type="checkbox"/> Inspect valve clearance. <input type="checkbox"/> Check idle speed. <input type="checkbox"/> Replace spark plugs. Do items in A, B, C.
108,750 mi/174,000 km	Do items in A.
112,500 mi/180,000 km	Do items in A, B.
116,250 mi/186,000 km	Do items in A.
120,000 mi/192,000 km/8 yrs	Do items in A, B, C, D, F.
120,000 mi/192,000 km/10 yrs	<input type="checkbox"/> Replace engine coolant, thereafter replace every 60,000 mi/96,000 km/5 yrs.

★1 : See Air Conditioning Filter on page 183 for replacement information under special driving conditions.

: See information on maintenance and emissions warranty, last column, page 147.

NOTE:

- Check engine oil and coolant at each fuel stop.
- Check and adjust valve clearance, cold engine, only if noisy.

Required Maintenance Record (for Normal and Severe Schedules)

You or the servicing dealer can record all completed maintenance here, whether you follow the schedule for normal conditions (page 148) or severe conditions (page 150). Keep the receipts for all work done on your vehicle.

3,750 mi 6,000 km	Signature or dealer stamp	mi/km
		Date
7,500 mi 12,000 km		mi/km
		Date
11,250 mi 18,000 km		mi/km
		Date
15,000 mi 24,000 km (or 1 year)		mi/km
		Date
18,750 mi 30,000 km		mi/km
		Date
22,500 mi 36,000 km		mi/km
		Date
26,250 mi 42,000 km		mi/km
		Date
30,000 mi 48,000 km (or 2 years)		mi/km
		Date

33,750 mi 54,000 km	Signature or dealer stamp	mi/km
		Date
37,500 mi 60,000 km		mi/km
		Date
41,250 mi 66,000 km		mi/km
		Date
45,000 mi 72,000 km (or 3 years)		mi/km
		Date
48,750 mi 78,000 km		mi/km
		Date
52,500 mi 84,000 km		mi/km
		Date
56,250 mi 90,000 km		mi/km
		Date
60,000 mi 96,000 km (or 4 years)		mi/km
		Date

CONTINUED

Required Maintenance Record (for Normal and Severe Schedules)

63,750 mi 102,000 km	Signature or dealer stamp	mi/km
		Date
67,500 mi 108,000 km		mi/km
		Date
71,250 mi 114,000 km		mi/km
		Date
75,000 mi 120,000 km (or 5 years)		mi/km
		Date
78,750 mi 126,000 km		mi/km
		Date
82,500 mi 132,000 km		mi/km
		Date
86,250 mi 138,000 km		mi/km
		Date
90,000 mi 144,000 km (or 6 years)		mi/km
		Date

93,750 mi 150,000 km	Signature or dealer stamp	mi/km
		Date
97,500 mi 156,000 km		mi/km
		Date
101,250 mi 162,000 km		mi/km
		Date
105,000 mi 168,000 km (or 7 years)		mi/km
		Date
108,750 mi 174,000 km		mi/km
		Date
112,500 mi 180,000 km		mi/km
		Date
116,250 mi 186,000 km		mi/km
		Date
120,000 mi 192,000 km (or 8 years)		mi/km
		Date

You should check the following items at the specified intervals. If you are unsure of how to perform any check, turn to the page given.

- Engine oil level — Check every time you fill the fuel tank. See page [119](#).
- Engine coolant level — Check the radiator reserve tank every time you fill the fuel tank. See page [120](#).
- Windshield washer fluid — Check the level in the reservoir monthly. If weather conditions cause you to use the washers frequently, check the reservoir each time you stop for fuel. See page [167](#).
- Brakes and clutch — Check the fluid level monthly. See page [170](#).
- Tires — Check the tire pressure monthly. Examine the tread for wear and foreign objects. See page [185](#).
- Lights — Check the operation of the headlights, parking lights, taillights, high-mount brake light, turn signals, brake lights, and license plate lights monthly. See page [192](#).

Fluid Locations

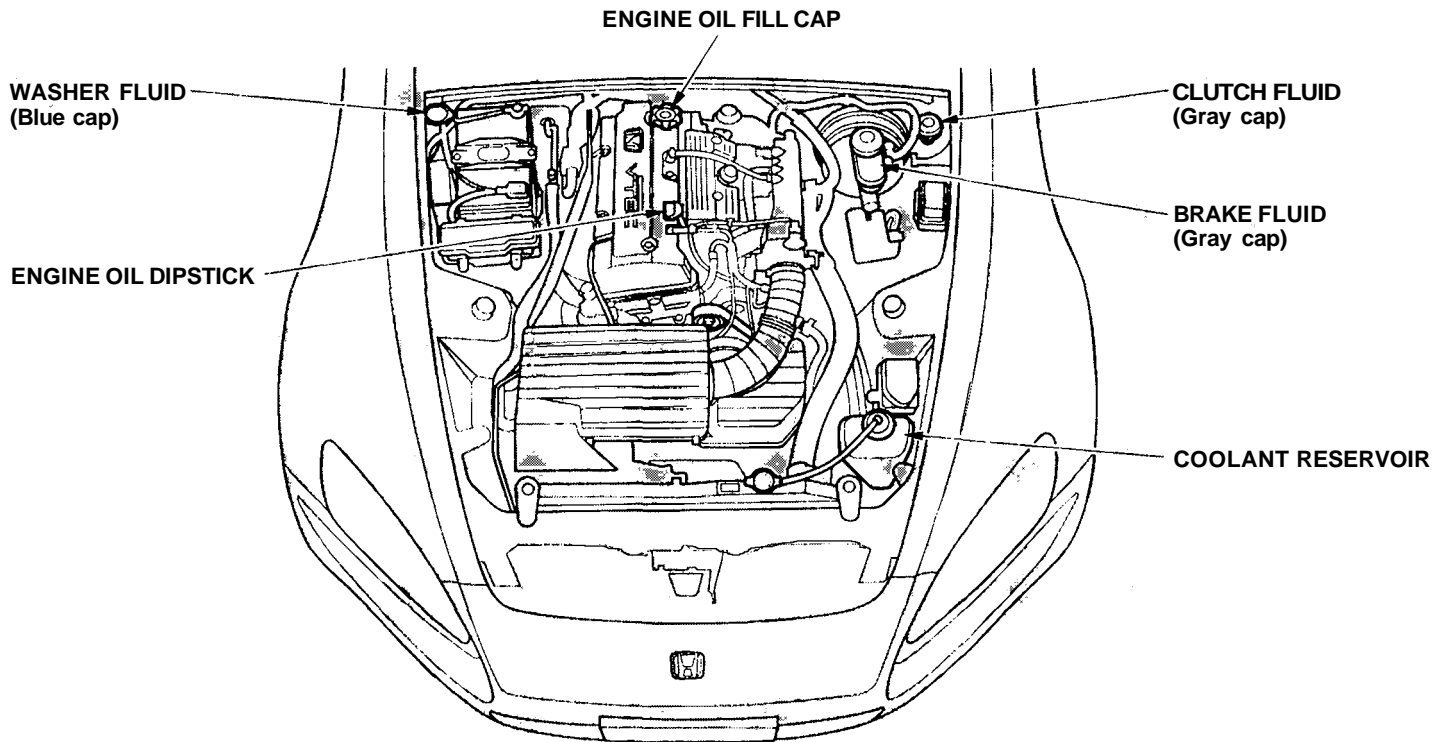

Adding Oil

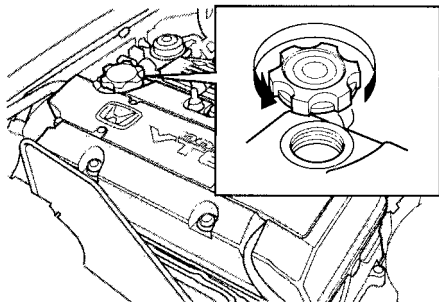

To add oil, unscrew and remove the engine oil fill cap on top of the left valve cover. Pour in the oil, and replace the engine oil fill cap. Tighten it securely. Wait a few minutes and recheck the oil level. Do not fill above the upper mark; you could damage the engine.

Recommended Oil

Oil is major contributor to your engine's performance and longevity. Always use a premium-grade detergent oil displaying the API Certification Seal. This seal indicates the oil is energy conserving, and that it meets the American Petroleum Institute's latest requirements. It is highly recommended that you use Honda Motor Oil in your vehicle for as long as you own it.

Make sure the API Certification Seal says "For Gasoline Engines."



API CERTIFICATION SEAL

CONTINUED

The numbers on the container's label tell you the oil's viscosity or weight. Select the oil for your car according to this chart.

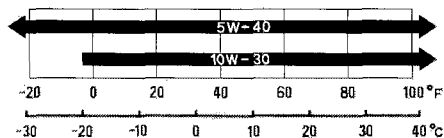

Ambient Temperature

An oil with a viscosity of 10W-30 is preferred for optimum fuel economy and year-round protection in your Honda. You may use a 5W-40 oil if the temperature in your area goes below 0 ° F (- 20° C).

Synthetic Oil

You may use a synthetic motor oil if it meets the same requirements given for conventional motor oil: energy conserving, a service classification of SJ, and the proper weight as shown on the chart. When using synthetic oil, you must follow the oil and filter change intervals given in the maintenance schedule.

Additives

Your Honda does not need any oil additives. Purchasing additives for the engine or transmission will not increase your car's performance or longevity. It only increases the cost of operating your car.

Changing the Oil and Filter

Always change the oil and filter according to the time and distance (miles/kilometers) recommendations in the maintenance schedule. The oil and filter collect contaminants that can damage your engine if they are not removed regularly.

Changing the oil and filter requires special tools and access from underneath the car. The car should be raised on a service station-type hydraulic lift for this service. Unless you have the knowledge and proper equipment, you should have this maintenance done by a skilled mechanic.

1. Run the engine until it reaches normal operating temperature, then shut it off.

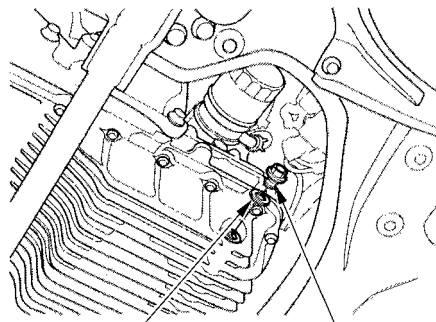

WASHER

OIL DRAIN BOLT

2. Remove the engine oil fill cap. Remove the oil drain bolt from the bottom of the engine. Drain the oil into an appropriate container.

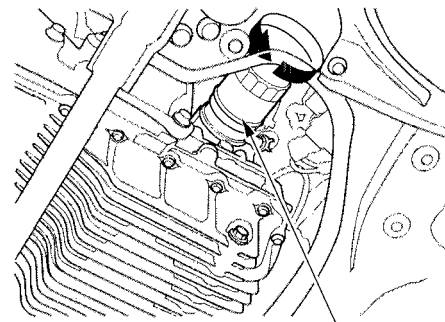

OIL FILTER

3. Remove the oil filter and let the remaining oil drain. A special wrench (available from your Honda dealer) is required to remove the filter.
4. Install a new oil filter according to instructions that come with it.

CONTINUED

- Put a new washer on the drain bolt, then reinstall the drain bolt.
Tighten it to:
33 lbf.ft (45 N.m, 4.6 kgf.m)
- Refill the engine with the recommended oil.
Engine oil change capacity
(including filter):
5.1 US qt (4.8 ℓ, 4.2 Imp qt)
- Replace the engine oil fill cap.
Start the engine. The oil pressure indicator light should go out within five seconds. If it does not, turn off the engine and reinspect your work.
- Let the engine run for several minutes and check the drain bolt and oil filter for leaks.
- Turn off the engine, let it sit for several minutes, then check the oil level. If necessary, add oil to bring the level to the upper mark on the dipstick.

NOTICE

Improper disposal of engine oil can be harmful to the environment. If you change your own oil, please dispose of the used oil properly. Put it in a sealed container and take it to a recycling center. Do not discard it in a trash bin or dump it on the ground.

Adding Engine Coolant

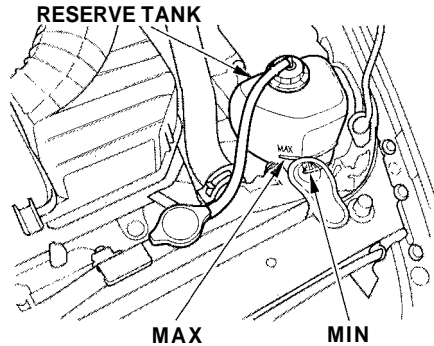

If the coolant level in the reserve tank is at or below the MIN line, add coolant to bring it up to the MAX line. Inspect the cooling system for leaks. This coolant should always be a mixture of 50 percent antifreeze and 50 percent water. Never add straight antifreeze or plain water.

Always use Honda All Season Antifreeze/Coolant Type 2. This coolant is pre-mixed with 50 percent antifreeze and 50 percent water. It does not require any additional mixing.

If it is not available, you may use another major-brand non-silicate coolant as a temporary replacement. Make sure it is a high-quality coolant recommended for aluminum engines. However, continued use of any non-Honda coolant can result in corrosion, causing the cooling system to malfunction or fail. Have the cooling system flushed and refilled with Honda antifreeze/coolant as soon as possible.

If the reserve tank is completely empty, you should also check the coolant level in the radiator.

Removing the radiator cap while the engine is hot can cause the coolant to spray out, seriously scalding you.

Always let the engine and radiator cool down before removing the radiator cap.

1. Make sure the engine and radiator are cool.

CONTINUED

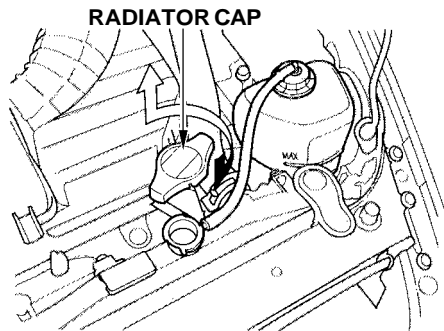

2. Turn the radiator cap counter-clockwise, without pressing down on it, until it stops. This relieves any pressure remaining in the cooling system.
3. Remove the radiator cap by pushing down and turning counterclockwise.

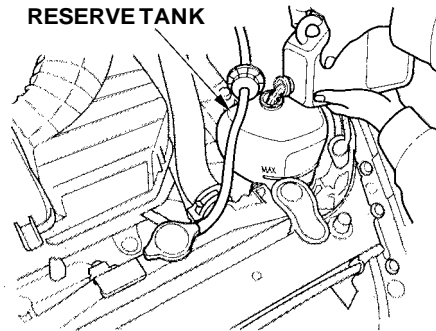

4. The coolant level should be up to the base of the filler neck. Add coolant if it is low.
5. Put the radiator cap back on. Tighten it fully.
6. Pour coolant into the reserve tank. Fill it to halfway between the MAX and MIN marks. Put the cap back on the reserve tank.

Do not add any rust inhibitors or other additives to your vehicle's cooling system. They may not be compatible with the coolant or engine components.

Replacing Engine Coolant

The cooling system should be completely drained and refilled with new coolant according to the time and distance recommendations in the maintenance schedule. Only use Honda All season Antifreeze/Coolant Type 2.

Draining the coolant requires access to the underside of the vehicle. Unless you have the tools and knowledge, you should have this maintenance done by a skilled mechanic.

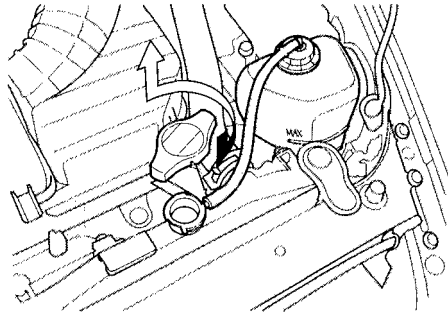

1. Turn the ignition ON (II). Turn the heater temperature control dial fully clockwise. Turn the ignition off.
2. Open the hood. Make sure the engine and radiator are cool to the touch.
3. Remove the radiator cap.

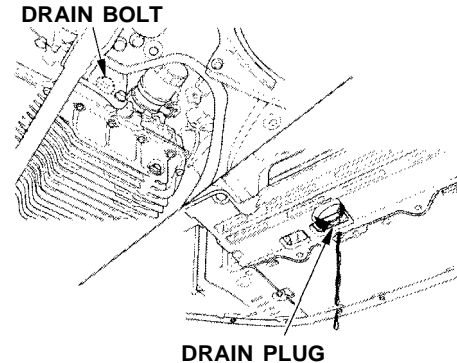

4. Loosen the drain plug on the bottom of the radiator. The coolant will drain through the splash guard. Remove the drain bolt and washer from the engine block.

CONTINUED

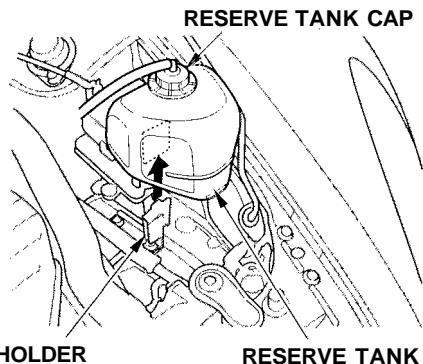

5. Remove the reserve tank from its holder by pulling it straight up. Drain the coolant, then put the tank back in its holder.

6. When the coolant stops draining, tighten the drain plug at the bottom of the radiator. Apply non-hardening sealant to the drain bolt threads, put a new washer on the drain bolt, and reinstall the bolt in the engine block. Tighten it securely. Tightening torque:
61 lbf·ft(83 N·m , 8.5 kgf·m)

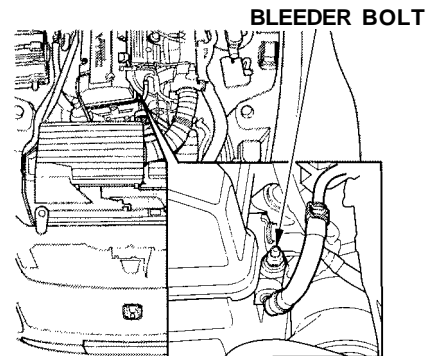

7. Loosen the bleeder bolt on top of the engine, and remove the bleeder cap near the engine oil fill cap.

BLEEDER CAP

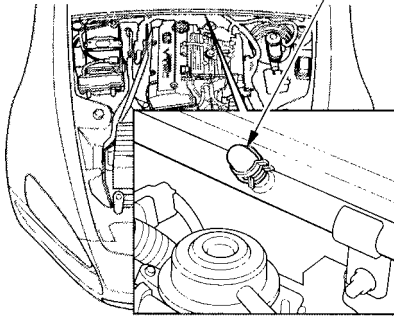

8. Pour Honda All Season Antifreeze/Coolant Type 2 into the radiator up to the base of the filler neck. This coolant is a mixture of 50 percent antifreeze and 50 percent water. Pre-mixing is not required.
The cooling system capacity is:
1.72 US gal (6.5 ℓ, 1.43 Imp gal)

Fill up to here

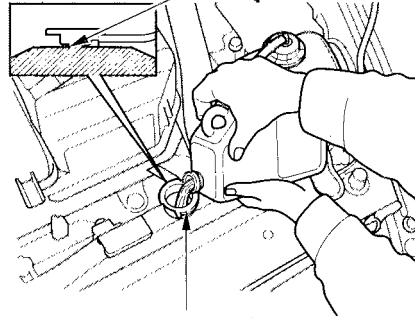

FILLER NECK

9. Tighten the bleeder bolt and reinstall the bleeder cap when coolant comes out in a steady stream with no bubbles.
10. Start the engine and let it run for about 30 seconds. Then turn off the engine.
11. Pour coolant into the radiator up to the base of the filler neck.

RESERVE TANK

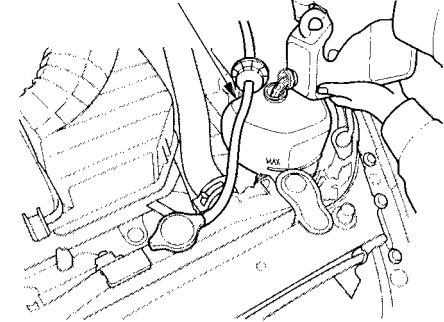

12. Fill the reserve tank to the MAX mark. Install the reserve tank cap.
13. Install the radiator cap, and tighten it to the first stop.
14. Start the engine and let it run until the radiator fan comes on two times. Then stop the engine.

CONTINUED

15. Remove the radiator cap.
16. Pour coolant into the radiator up to the base of the filler neck and into the reserve tank up to the MAX mark.
17. Start the engine and hold it at 1,500 rpm until the radiator fan comes on. Turn off the engine. Check the coolant level in the radiator and add coolant if needed.
18. Install the radiator cap, and tighten it fully.
19. If necessary, fill the reserve tank to the MAX mark. Install the reserve tank cap.

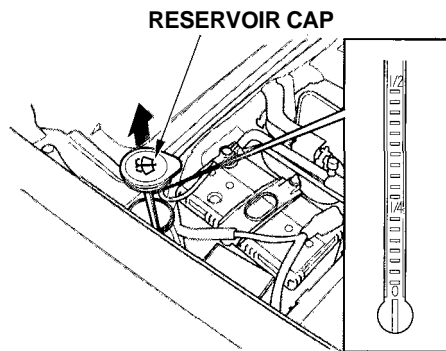

Check the reservoir's fluid level by removing the cap and looking at the level gauge attached to the cap.

Check the level in the windshield washer reservoir at least monthly during normal usage. In bad weather, when you use the washers often, check the level every time you stop for fuel.

The windshield washer reservoir is located in the rear of the engine compartment on the passenger's side.

Fill the reservoir with a good-quality windshield washer fluid. This increases the cleaning capability and prevents freezing in cold weather.

When you refill the reservoir, clean the edges of the windshield wiper blades with windshield washer fluid on a clean cloth. This will help to condition the blade edges.

NOTICE

Do not use engine antifreeze or a vinegar/water solution in the windshield washer reservoir.

Antifreeze can damage your car's paint, while a vinegar/water solution can damage the windshield washer pump.

Use only commercially-available windshield washer fluid.

6-speed Manual Transmission Fluid

FILLER BOLT

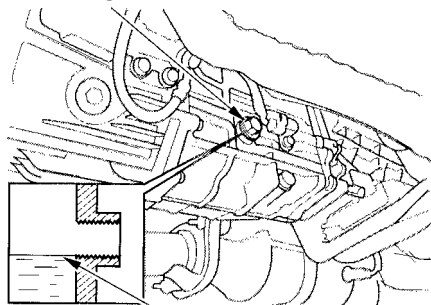

CORRECT LEVEL

Check the fluid level with the transmission at normal operating temperature and the car sitting on level ground. Remove the transmission filler bolt and carefully feel inside the bolt hole with your finger. The fluid level should be up to the edge of the bolt hole. If it is not, add Honda Manual Transmission Fluid (MTF) until it starts to run out of the hole. Reinstall the filler bolt and tighten it securely.

If Honda MTF is not available, you may use an API service SG, SH or SJ grade motor oil with a viscosity of SAE 10W-30 or 10W-40 as a temporary replacement. An SG grade is preferred, but an SH or SJ grade may be used if SG is not available. However, motor oil does not contain the proper additives and continued use can cause stiffer shifting. Replace as soon as it is convenient.

The transmission should be drained and refilled with new fluid according to the time and distance recommendations in the maintenance schedule.

FILLER BOLT

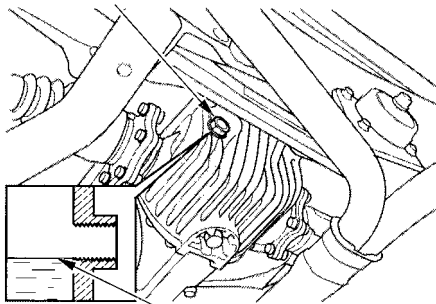

CORRECT LEVEL

Check the fluid level with the differential at normal operating temperature and the vehicle sitting on level ground. Remove the differential fluid filler bolt and washer and carefully feel inside the bolt hole with your finger. The fluid level should be up to the edge of the bolt hole. If it is not, slowly add fluid until it starts to run out of the hole.

Use a SAE 90 viscosity hypoid gear oil, API service classified GL5 or GL6 only, in the differential.

Put a new washer on the filler bolt, then reinstall the filler bolt. Tighten it securely. Tightening torque:
33 lbf·ft (45N·m , 4.6 kgf·m)

The differential should be drained and refilled with new fluid according to the time and distance recommendations in the maintenance schedule.

Brake and Clutch Fluid

Check the fluid level in the reservoirs monthly. There are two reservoirs. They are:

- Brake fluid reservoir
- Clutch fluid reservoir

The brake fluid should be replaced according to the time recommendation in the maintenance schedule.

Brake Fluid

Always use Honda Heavy Duty Brake Fluid DOT 3. If it is not available, you should use only DOT 3 or DOT 4 fluid, from a sealed container, as a temporary replacement. However, the use of any non-Honda brake fluid can cause corrosion and decrease the life of the system. Have the brake system flushed and refilled with Honda Heavy Duty Brake Fluid DOT 3 as soon as possible.

Brake fluid marked DOT 5 is not compatible with your car's braking system and can cause extensive damage.

Brake System

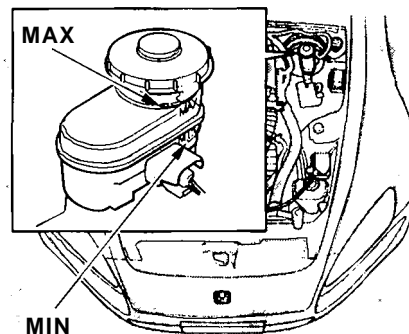

The fluid level should be between the MIN and MAX marks on the side of the reservoir. If the level is at or below the MIN mark, your brake system needs attention. Have the brake system inspected for leaks or worn brake pads.

Clutch System

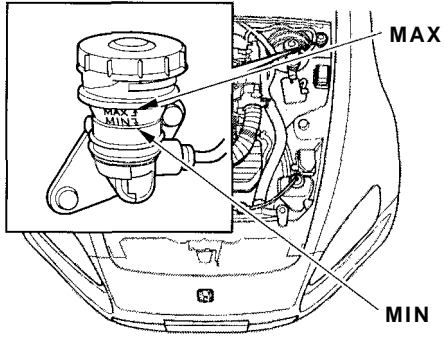

The fluid should be between the MIN and MAX marks on the side of the reservoir. If it is not, add brake fluid to bring it up to that level. Use the same fluid specified for the brake system.

Low fluid level can indicate a leak in the clutch system. Have this system inspected as soon as possible.

Air Cleaner Element

The air cleaner element should be replaced according to the time and distance recommendations in the maintenance schedule.

Follow the replacement procedure for removal and reinstallation.

Replacement

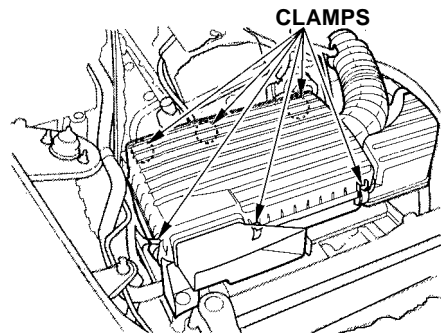

To replace it:

1. Unsnap the six clamps holding the air cleaner housing cover.
2. Remove the air cleaner housing cover. Disconnect the air intake duct from the air cleaner element.

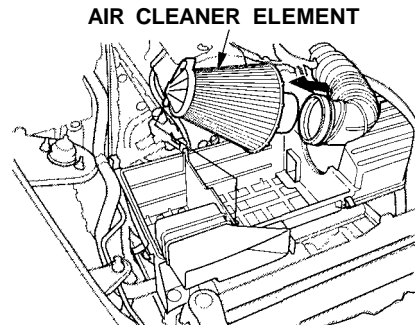

3. Remove the old air cleaner element.
4. Carefully clean the inside of the air cleaner housing with a damp rag.

5. Attach the new air cleaner element to the duct. Install the new air cleaner element in the air cleaner housing. Make sure the pin on the edge of the element fits in the hole in the bottom of the housing.
6. Reinstall the air cleaner housing cover, snap the six clamps back into place.

Hood Latch

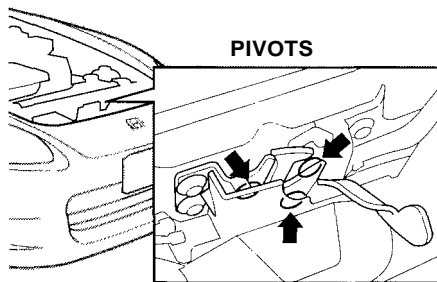

Clean the hood latch assembly with a mild cleaner, then lubricate it with a multipurpose grease. Lubricate all the moving parts, including the pivot. Follow the time and distance recommendations in the Maintenance Schedule. If you are not sure how to clean and grease the latch, contact your Honda dealer.

Spark Plugs

The spark plugs in your car are a special platinum-tipped design for longer life. They only need to be replaced every 7 years or 105,000 miles (168,000 km), whichever comes first.

Replacement

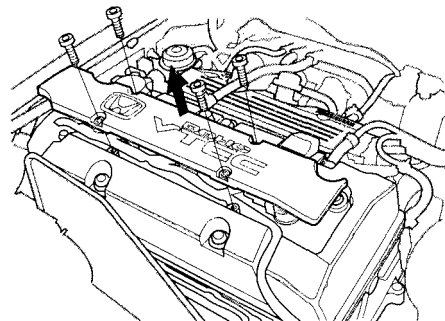

1. Remove the four hexagon socket head cap bolts holding the ignition coil cover.
2. Clean up any dirt and oil that have collected around the ignition coils.

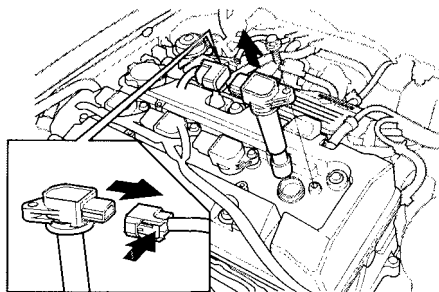

3. Remove the bolt holding the ignition coil and pull the ignition coil straight up slightly. Disconnect the ignition coil connector by pushing the tab and pulling the connector back. Pull the ignition coil all the way up.
4. Remove the spark plug with a five-eighths inch (16 mm) spark plug socket.

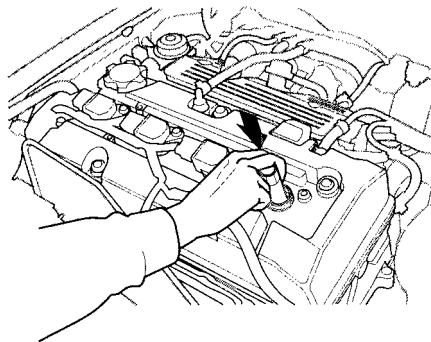

5. Put the new spark plug into the socket; then screw it into the hole. Screw it in by hand so you do not crosstread it.

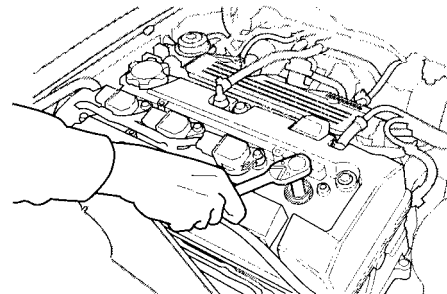

6. Torque the spark plug. (If you do not have a torque wrench, tighten the spark plug two-thirds of a turn after it contacts the cylinder head.)
Tightening torque:
18 lbf-ft (25 N·m, 2.5 kgf·m)

CONTINUED

NOTICE

Tighten the spark plugs carefully. A spark plug that is too loose can overheat and damage the engine. Overtightening can cause damage to the threads in the cylinder head.

7. Install the ignition coil. Reinstall the bolt.
8. Repeat this procedure for the other three spark plugs.
9. Reinstall the cover on the cylinder bank. Reinstall the four hexagon socket head cap bolts.

Specifications:

NGK: **PFR7G-11S**
DENSO: **PK22PR-L11S**

Spark Plug Gap:

0.043 in $\begin{matrix} -0 \\ -0.004 \text{ in} \end{matrix}$ (**1.1 mm** $\begin{matrix} -0 \\ 0.1 \text{ mm} \end{matrix}$)

Check the condition of your car's battery monthly. You should check the color of the test indicator window, and for corrosion on the terminals.

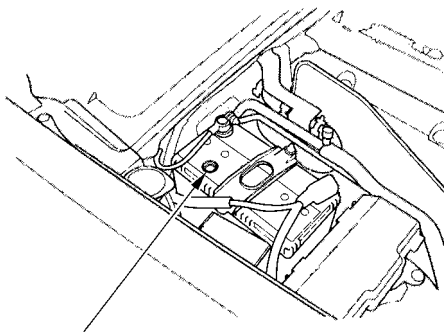

TEST INDICATOR WINDOW

Check the battery condition by looking at the test indicator window on the battery. The label on the battery explains the test indicator's colors.

Check the battery terminals for corrosion (a white or yellowish powder). To remove it, cover the terminals with a solution of baking soda and water. It will bubble up and turn brown. When this stops, wash it off with plain water. Dry off the battery with a cloth or paper towel. Coat the terminals with grease to help prevent future corrosion.

WARNING: Battery posts, terminals and related accessories contain lead and lead compounds. **Wash hands after handling.**

CONTINUED

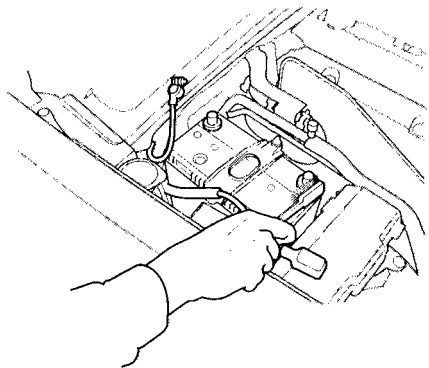

If the terminals are severely corroded, clean them with baking soda and water. Then use a wrench to loosen and remove the cables from the terminals. Always disconnect the negative (—) cable first and reconnect it last. Clean the battery terminals with a terminal cleaning tool or wire brush. Reconnect and tighten the cables, then coat the terminals with grease.

If you need to connect the battery to a charger, disconnect both cables to prevent damage to the car's electrical system.

The battery gives off explosive hydrogen gas during normal operation.

A spark or flame can cause the battery to explode with enough force to kill or seriously hurt you.

Wear protective clothing and a face shield, or have a skilled mechanic do the battery maintenance.

If your car's battery is disconnected or goes dead, the audio system will disable itself. The next time you turn on the radio you will see "Code" in the frequency display. Use the Preset buttons to enter the five-digit code (see page [114](#)).

NOTICE

Charging the battery with the cables connected can seriously damage your car's electronic controls. Detach the battery cables before connecting the battery to a charger.

Wiper Blades

Check the condition of the wiper blades at least every six months. Look for signs of cracking in the rubber, or areas that are getting hard. Replace the blades if you find these signs, or they leave streaks and unwiped areas when used.

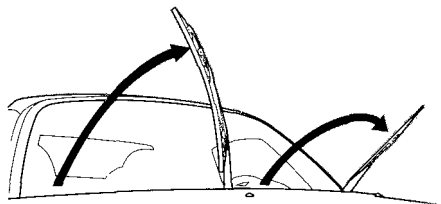

To replace the blade:

1. Raise the wiper arm off the windshield.

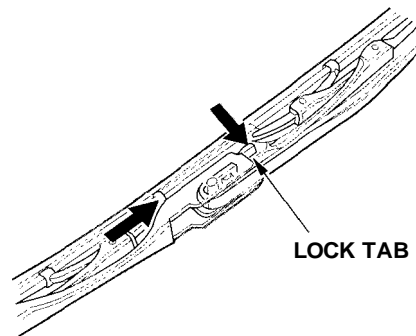

2. Disconnect the blade assembly from the wiper arm by pushing in the lock tab. Hold it in while you push the blade assembly toward the base of the arm.

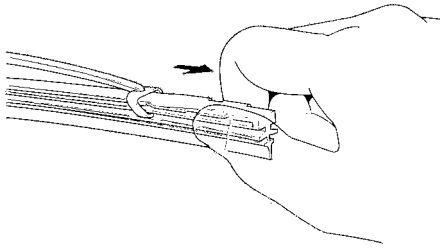

3. Remove the blade from its holder by grasping the tabbed end of the blade. Pull firmly until the tabs come out of the holder.

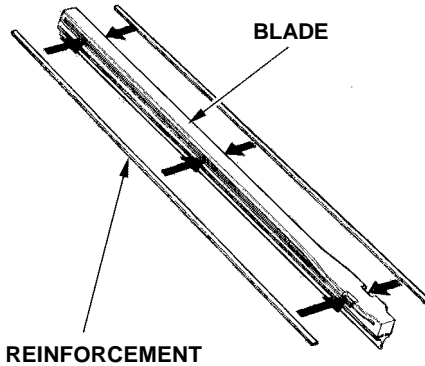

4. Examine the new wiper blades. If they have no plastic or metal reinforcement along the back edge, remove the metal reinforcement strips from the old wiper blade and install them in the slots along the edge of the new blade.

5. Slide the new wiper blade into the holder until the tabs lock.
6. Slide the wiper blade assembly onto the wiper arm. Make sure it locks in place.
7. Lower the wiper arm down against the windshield.

Air Conditioning System

Your car's air conditioning is a sealed system. Any major maintenance, such as recharging, should be done by a qualified mechanic. You can do a couple of things to make sure the air conditioning works efficiently.

Periodically check the engine's radiator and air conditioning condenser for leaves, insects, and dirt stuck to the front surface. These block the air flow and reduce cooling efficiency. Use a light spray from a hose or a soft brush to remove them.

NOTICE

The condenser and radiator fins bend easily. Only use a low-pressure spray or soft-bristle brush to clean them.

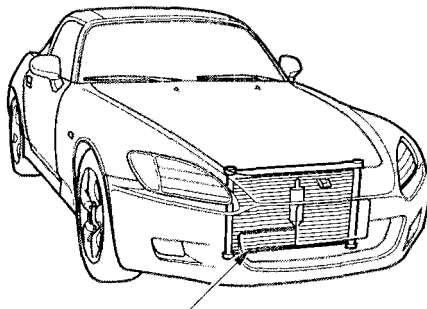

AIR CONDITIONING CONDENSER

Run the air conditioning at least once a week during the cold weather months. Run it for at least ten minutes while you are driving at a steady speed with the engine at normal operating temperature. This circulates the lubricating oil contained in the refrigerant.

If the air conditioning does not get as cold as before, have your dealer check the system. Recharge the system with Refrigerant HFC-134a (R-134a). (See Specifications on page [247](#).)

NOTICE

Whenever you have the air conditioning system serviced, make sure the service facility uses a refrigerant recycling system. This system captures the refrigerant for reuse. Releasing refrigerant into the atmosphere can damage the environment.

The air conditioning filter removes pollen and dust from outside air the heating and cooling system brings into the interior. It should be replaced according to the time and distance recommendations in the maintenance schedule.

This filter should be replaced every 30,000 miles (48,000 km) under normal conditions. It should be replaced every 15,000 miles (24,000 km) if you drive primarily in urban areas that have high concentrations of soot in the air from industry and diesel-powered vehicles. Replace it more often if air flow from the climate control system becomes less than usual. Have the air conditioning filter replaced by your Honda dealer.

Replacement

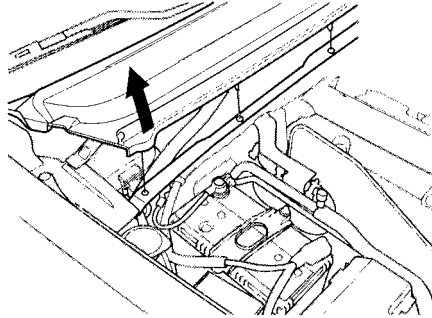

The air conditioning filter is located in the engine compartment on the passenger's side near the base of the windshield.

1. Open the hood. Unclip the windshield base by pulling it up.

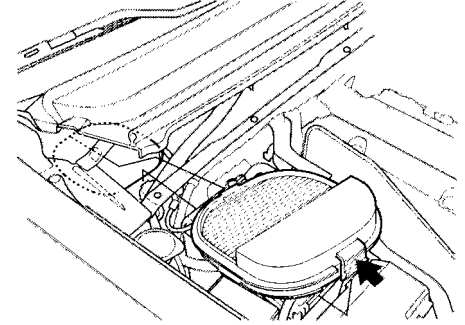

2. Push the tab on the air conditioning filter to unlock it from the holder.
3. Remove the old filter. Put a new filter in the holder and push it in until it locks.
4. Put the pins on the windshield base into their mating holes on the support, and push the base down until the pins snap in.

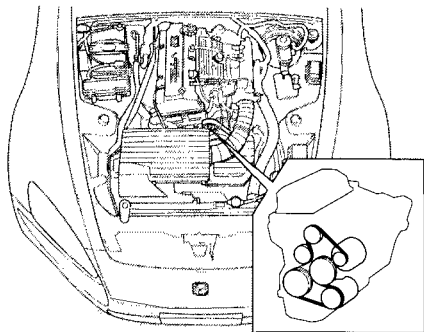

You should check the condition of the drive belt every 2 years. Examine the edges of belt for cracks or fraying.

Auto-tensioner

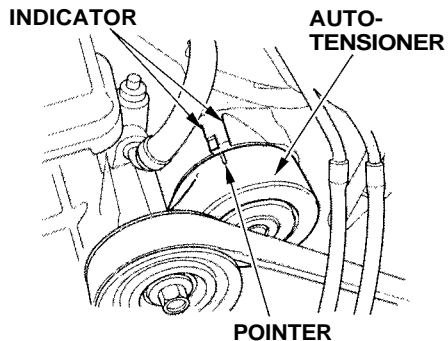

An auto-tensioner adjusts the tension of the drive belt.

The pointer on the auto-tensioner should be between the two lines of the indicator. If the pointer is not between the lines, contact your Honda dealer.

To safely operate your car, your tires must be the proper type and size, in good condition with adequate tread, and correctly inflated. The following pages give more detailed information on how and when to check air pressure, how to inspect your tires for damage and wear, and what to do when your tires need to be replaced.

Using tires that are excessively worn or improperly inflated can cause a crash in which you can be seriously hurt or killed.

Follow all instructions in this owner's manual regarding tire inflation and maintenance.

Inflation

Keeping the tires properly inflated provides the best combination of handling, tread life and riding comfort. Underinflated tires wear unevenly, adversely affect handling and fuel economy, and are more likely to fail from being overheated. Overinflated tires can make your car ride more harshly, are more prone to damage from road hazards, and wear unevenly.

We recommend that you visually check your tires every day. If you think a tire might be low, check it immediately with a tire gauge.

CONTINUED

Use a gauge to measure the air pressure at least once a month. Even tires that are in good condition may lose one to two psi (10 to 20 kPa, 0.1 to 0.2 kgf/cm²) per month. Remember to check the spare tire at the same time you check all the other tires.

Check the pressure in the tires when they are cold. This means the car has been parked for at least three hours. If you have to drive the car before checking the tire pressure, the tires can still be considered "cold" if you drive less than 1 mile (1.6 km).

If you check the pressure when the tires are hot (the car has been driven several miles), you will see readings 4 to 6 psi (30 to 40 kPa, 0.3 to 0.4 kgf/cm²) higher than the cold reading. This is normal. Do not let air out to match the specified cold pressure. The tire will be underinflated.

You should get your own tire pressure gauge and use it whenever you check your tire pressures. This will make it easier for you to tell if a pressure loss is due to a tire problem and not due to a variation between gauges.

Recommended Tire Pressures for Normal Driving

The following chart shows the recommended cold tire pressures for most normal driving conditions and speeds. Tire pressures for high speed driving are the same as for normal driving.

Front:

Tire Size	Cold Tire Pressure for Normal Driving
205/55R16 89W	32 psi (220 kPa , 2.2 kgf/cm ²)

Rear:

Tire Size	Cold Tire Pressure for Normal Driving
225/50R16 92W	32 psi (220 kPa , 2.2 kgf/cm ²)

The compact spare tire pressure is: 60 psi (420 kPa , 4.2 kgf/cm²)

These pressures are also given on the tire information label on the driver's doorjamb.

Tubeless tires have some ability to self-seal if they are punctured. However, because leakage is often very slow, you should look closely for punctures if a tire starts losing pressure.

Inspection

Every time you check inflation, you should also examine the tires for damage, foreign objects, and wear. You should look for:

- Bumps or bulges in the tread or side of the tire. Replace the tire if you find either of these conditions.
- Cuts, splits, or cracks in the side of the tire. Replace the tire if you can see fabric or cord.
- Excessive tread wear.

INDICATOR LOCATION MARKS

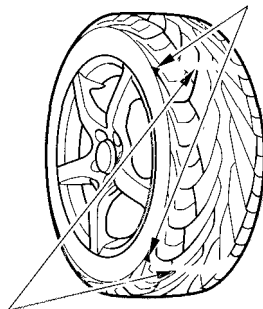

TREAD WEAR INDICATORS

Your car's tires have wear indicators molded into the tread. When the tread wears down to that point, you will see a 1/2 inch (12.7 mm) wide band running across the tread. This shows there is less than 1/16 inch (1.6 mm) of tread left on the tire. A tire that is this worn gives very little traction on wet roads. You should replace the tire if you can see the tread wear indicator in three or more places around the tire.

Maintenance

In addition to proper inflation, correct wheel alignment helps to decrease tire wear. If you find a tire is worn unevenly, have your dealer check the wheel alignment.

The tires were properly balanced by the factory. They may need to be rebalanced at some time before they are worn out. Have your dealer check the tires if you feel a consistent vibration while driving. A tire should always be rebalanced if it is removed from the wheel for repair.

Make sure the installer balances the wheels when you have new tires installed. This increases riding comfort and tire life. Your car's original tires were dynamic or "spin" balanced at the factory. For best results, have the installer perform a dynamic balance.

NOTICE

Improper wheel weights can damage your vehicle's aluminum wheels. Use only genuine Honda wheel weights for balancing.

Tire Rotation

You should not rotate your Honda's tires. The front and rear tires are different sizes, so they cannot be rotated front-to-rear. The original-equipment tires on your Honda have a unidirectional tread pattern, so they cannot be rotated side-to-side.

Tire Wear

The tires that came on your car were designed and constructed to provide superior grip during acceleration, braking, and cornering. As a trade-off, they will wear more rapidly than tires used on ordinary passenger cars. Because of the car's weight distribution, and the fact that they are the driving wheels, you may expect the rear tires to wear more rapidly than the front tires.

You should carefully inspect your car's tires for wear, damage, and proper inflation every 7,500 miles (12,000km) (see page [185](#)).

Replacing Tires and Wheels

The tires that came with your car were selected to match the performance capabilities of the car while providing the best combination of handling, ride comfort, and long life. You should replace them with radial tires of the same size, load range, speed rating, and maximum cold tire pressure rating (as shown on the tire's sidewall). Mixing radial and bias-ply tires on your car can reduce its braking ability, traction, and steering accuracy.

Installing improper tires on your car can affect handling and stability. This can cause a crash in which you can be seriously hurt or killed.

Always use the size and type of tires recommended in this owner's manual.

It is best to replace all four tires at the same time. If that is not possible or necessary, then replace the two front tires or the two rear tires as a pair. Replacing just one tire can seriously affect your car's handling.

CONTINUED

The ABS works by comparing the speed of the wheels. When replacing tires, use the same size originally supplied with the car. Tire size and construction can affect wheel speed and may cause the system to work inconsistently.

If you ever need to replace a wheel, make sure the wheel's specifications match those of the original wheel that came on your car. Replacement wheels are available at your Honda dealer.

Wheels and Tires

Wheels:

Front:

16 x 6 1/2 JJ

Rear:

16 x 7 1/2 JJ

Tires:

Front:

205/55R 16 89W

Rear:

225/50R 16 92W

See page [248](#) for information about DOT Tire Quality Grading.

Winter Driving

Tires that are marked "M + S" on the sidewall have an all-weather tread design. They should be suitable for most winter driving conditions. Tires without these markings are designed for optimum traction in dry conditions. They may not provide adequate performance in winter driving.

For the best performance in snowy or icy conditions, you should install snow tires or tire chains. They may be required by local laws under certain conditions.

Snow Tires

If you mount snow tires on your Honda, make sure they are radial tires of the same size and load range as the original tires. Mount snow tires on all four wheels to balance your vehicle's handling in all weather conditions. Keep in mind the traction provided by snow tires on dry roads may not be as high as your vehicle's original equipment tires. You should drive cautiously even when the roads are clear. Check with the tire dealer for maximum speed recommendations.

Tire Chains

Because your Honda has limited tire clearance, mount only SAE Class "S" cable-type traction devices on the rear tires. Use traction devices only when required by driving conditions or local laws. Make sure they are the correct size for your tires.

Metal link-type "chains" should not be used. No matter how tight they seem to be installed, they can come into contact with the body and suspension, causing serious damage.

When installing cables, follow the manufacturer's instructions and mount them as tightly as you can. Drive slowly with them installed. If you hear them coming in contact with the body or chassis, stop and investigate. Make sure the cables are installed tightly, and that they are not contacting the brake lines or suspension.

Remove them as soon as you begin

driving on cleared roads.

NOTICE

Cables that are the wrong size or improperly installed can damage your car's brake lines, suspension, body, and wheels. Stop driving if they are hitting any part of the car.

Lights

Check the operation of your car's exterior lights at least once a month. A burned out bulb can create an unsafe condition by reducing your car's visibility and the ability to signal your intentions to other drivers.

SIDE TURN SIGNAL LIGHT

TURN SIGNAL

**FRONT PARKING AND
SIDE MARKER LIGHT**

**LOW BEAM
HEADLIGHT**

**HIGH BEAM
HEADLIGHT**

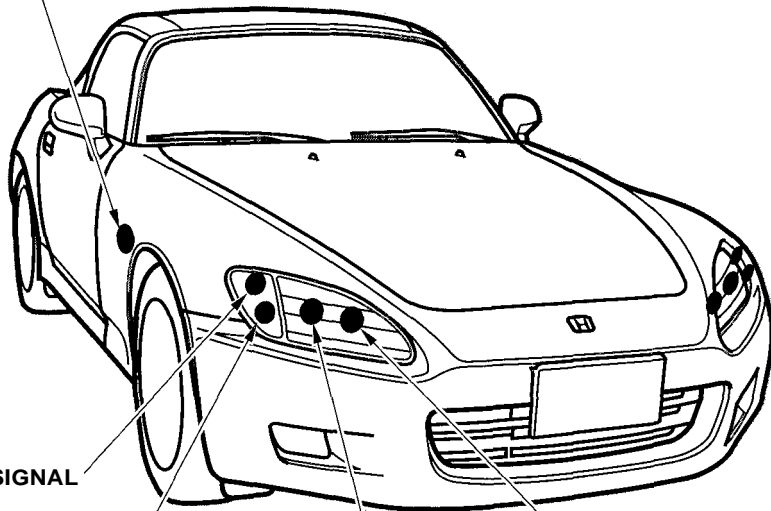

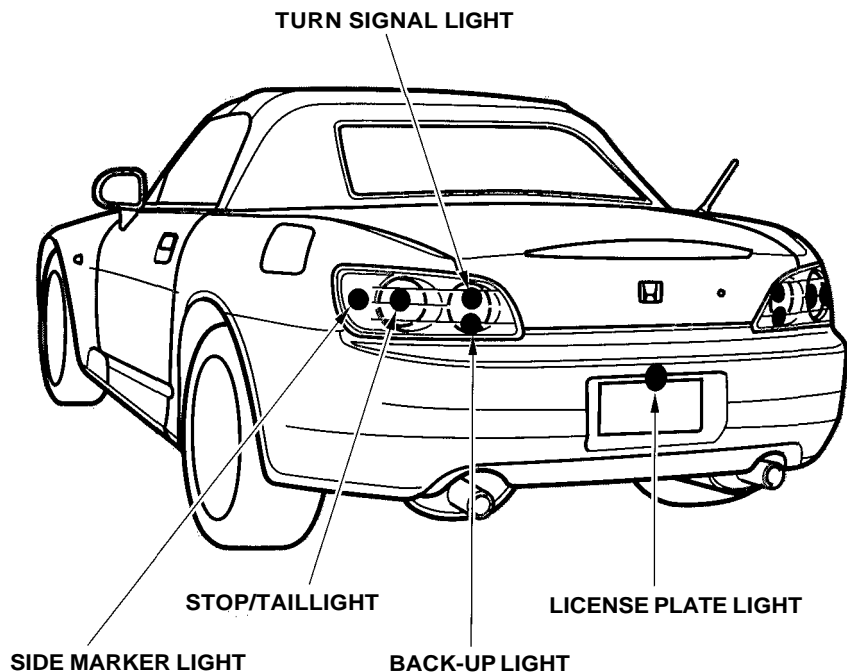

Check the following:

- Headlights (low and high beam)
- Parking lights
- Taillights
- Brake lights
- Turn signals
- Back-up lights
- Hazard light function
- License plate light
- Side marker lights
- Daytime running lights
(Canadian cars)

If you find any bulbs are burned out, replace them as soon as possible. Refer to the chart on page [247](#) to determine what type of replacement bulb is needed.

Replacing a Headlight Bulb

The low beam headlight bulbs are a type of high voltage discharge tube. High voltage can remain in the circuit even with the light switch off and the key removed. Because of this, you should not attempt to examine or change a low beam headlight bulb yourself. If a low beam headlight bulb fails, take the car to your dealer to have it replaced.

Halogen bulbs are used for the high beam headlight bulbs. When replacing a high beam headlight bulb, handle it by its base and protect the glass from contact with your skin or hard objects. If you touch the glass, clean it with denatured alcohol and a clean cloth.

NOTICE

Halogen headlight bulbs get very hot when lit. Oil, perspiration, or a scratch on the glass can cause the bulb to overheat and shatter.

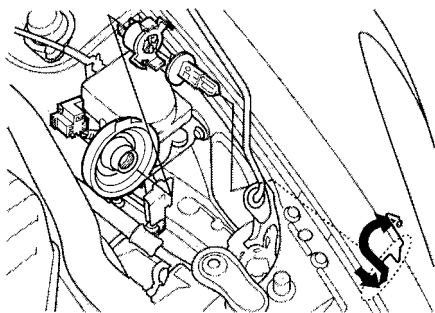

1. Open the hood.
If you need to change the high beam headlight bulb on the left side, remove the coolant reserve tank from its holder by pulling it straight up.
2. Remove the electrical connector from the bulb by squeezing the connector to unlock the tab, then slide the connector off the bulb.

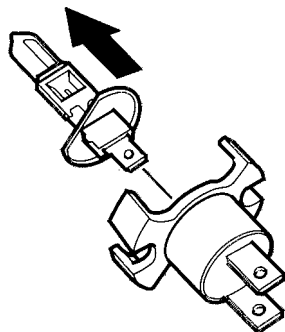

3. Remove the rubber weather seal by pulling on the tab.
4. Unclip the end of the hold-down wire from its slot. Pivot it out of the way and remove the bulb socket.
5. Pull the bulb straight out of its socket.
Push the new bulb straight into the socket until it bottoms.

6. Insert the socket back into the headlight assembly. Make sure the bulb is installed correctly by looking through the headlight lens. The pins on the base of the bulb should fit in the holes in the headlight assembly. Pivot the hold-down wire back in place and clip the end into the slot.
7. Install the rubber seal over the back of the headlight assembly. Make sure it is right side up; it is marked "TOP."
8. Push the electrical connector onto the new bulb.
Turn on the headlights to test the new bulb.

Replacing Front Turn Signal and Side Marker Light Bulbs

1. If you are changing the bulb on the driver's side, start the engine, turn the steering wheel all the way to the right, and turn off the engine. If you are changing the bulb on the passenger's side, turn the steering wheel to the left.

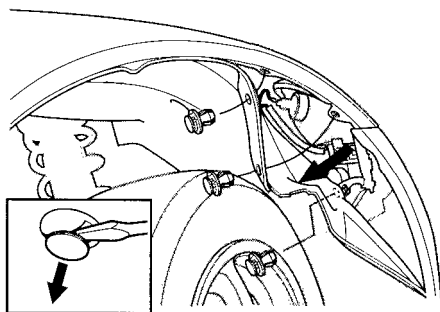

2. Use a flat-tipped screwdriver to remove the three holding clips from the inner fender.
3. Pull the inner fender cover back.
4. Remove the socket from the headlight assembly by turning it one-quarter turn counterclockwise.
5. Pull the bulb straight out of its socket.

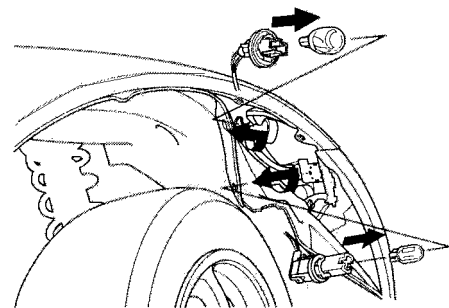

6. Install the new bulb in the socket.
7. Insert the socket back into the headlight assembly. Turn it clockwise to lock it in place.
8. Test the lights to make sure the new bulb is working.
9. Put the inner fender in place. Install the two holding clips. Lock each clip in place by pushing on the center.

Replacing a Side Turn Signal Bulb

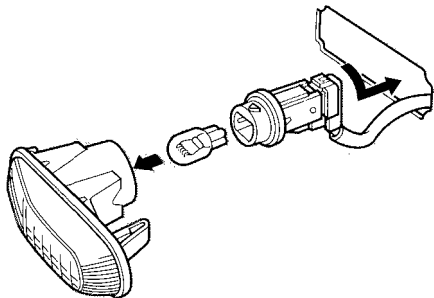

1. Use a small flat blade screwdriver to pry carefully on the back edge of the side turn signal assembly until it pops out of the body.
2. Turn the bulb holder one-quarter turn counterclockwise to remove it from the lens.
3. Pull the bulb straight out of its socket.
Push the new bulb straight into the socket until it bottoms.
4. Put the bulb holder back into its hole in the lens, and turn it clockwise until it locks.
5. Test the lights to make sure the new bulb is working.
6. Put the side turn signal assembly back into the body, front first. Push on the back edge until it snaps into place.

Replacing Rear Bulbs

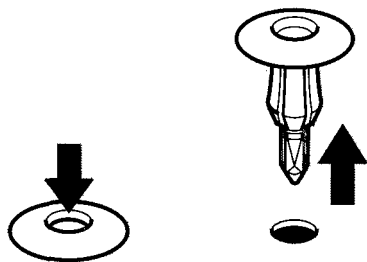

1. Open the trunk.
2. Remove the fasteners from the trunk lining. To remove a fastener, push on the center of the head until it pops in. Then pull it out.
3. Pull the lining back.

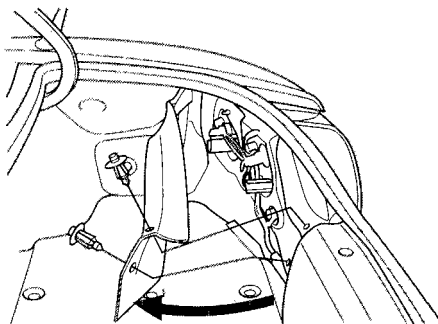

4. Determine which of the four bulbs is burned out: stop/taillight, back-up light, turn signal, or side marker.

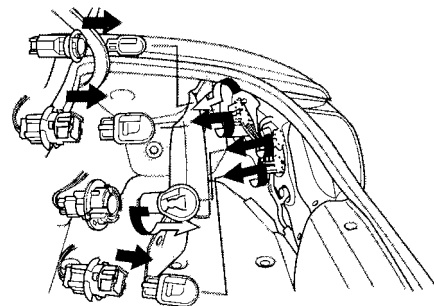

5. Remove the socket by turning it one-quarter turn counterclockwise.
6. Remove the burned out bulb. To remove the stop/taillight, back-up or side marker light bulb, pull the bulb straight out of its socket. To remove the turn signal light bulb, push it in and turn it counterclockwise until it unlocks.

- 7. Install the new bulb in the socket.
- 8. Push the socket into the light assembly and turn it clockwise until it locks.
- 9. Test the lights to make sure the new bulb is working.

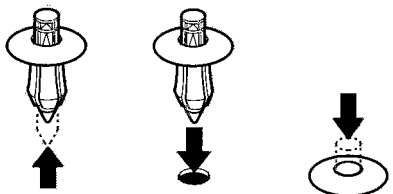

- 10. Install the trunk lining and secure it with the fasteners. To reinstall a fastener, reset the fastener by pushing on the pointed end until it pops back almost flush with the fingers on the housing. Put the fastener in the hole of the trunk lining and push on the center until it locks (the center is flush with the head).

Replacing a Rear License Plate Bulb

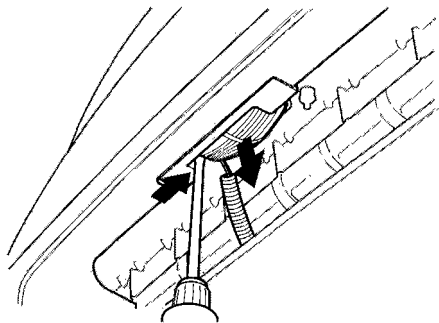

1. Insert a flat blade screwdriver between the left edge of the lens and the housing. The lens will come down.

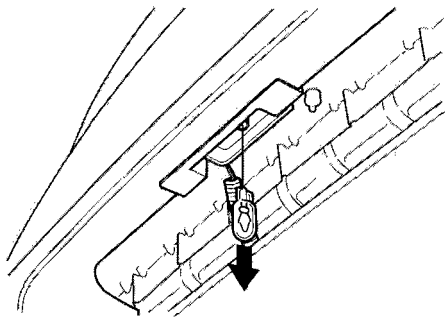

2. Pull the bulb straight out of its socket. Push the new bulb in until it bottoms in the socket.
3. Test the lights to make sure the new bulb is working.
4. Put the lens back into the light assembly, right side first. Push on the left edge until it snaps into place.

Replacing an Interior Light Bulb

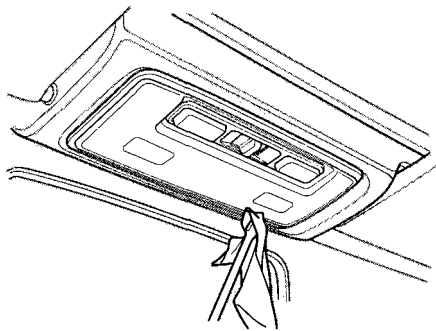

1. Remove the lens by carefully prying on the front edge of the lens near both sides.

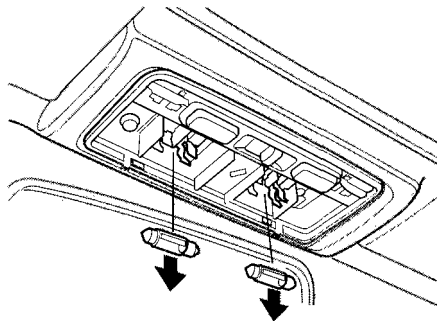

2. Remove the bulb by pulling it straight out of its metal tabs.
3. Push the new bulb into the metal tabs. Snap the lens back in place.

Replacing the Trunk Light Bulb

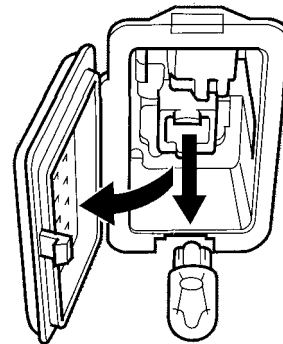

1. Open the trunk. Pull down the trunk light cover.
2. Remove the bulb by pulling it straight out of its metal tabs.
3. Push the new bulb into the metal tabs.
4. Push the cover back in place.

Storing Your Car

If you need to park your car for an extended period (more than one month), there are several things you should do to prepare it for storage. Proper preparation helps prevent deterioration and makes it easier to get your car back on the road. If possible, store your car indoors.

- Fill the fuel tank.
- Change the engine oil and filter (see page 159).
- Wash and dry the exterior completely.
- Clean the interior. Make sure the carpeting, floor mats, etc. are completely dry.
- Raise the convertible top cover.
- Leave the parking brake off. Put the transmission in Reverse.

- Block the rear wheels.
- If the car is to be stored for a longer period, it should be supported on jackstands so the tires are off the ground.
- Leave one window open slightly (if the car is being stored indoors).
- Disconnect the battery.
- Support the front wiper blade arms with a folded towel or rag so they do not touch the windshield.
- To minimize sticking, apply a silicone spray lubricant to all door and trunk seals. Also, apply a vehicle body wax to the painted surfaces that mate with the door and trunk seals.

- Cover the car with a "breathable" cover, one made from a porous material such as cotton. Nonporous materials, such as plastic sheeting, trap moisture, which can damage the paint.
- If possible, run the engine for a while periodically (preferably once a month).

If you store your car for 12 months or longer, have your Honda dealer perform the inspections called for in the 24 months/30,000 miles (48,000 km) maintenance schedule as soon as you take it out of storage (see page 148). The replacements called for in the maintenance schedule are not needed unless the car has actually reached that time or mileage.

Regular cleaning and polishing of your Honda helps to keep it "new" looking. This section gives you hints on how to clean your car and preserve its appearance: the paint, brightwork, wheels and interior. Also included are several things you can do to help prevent corrosion.

Exterior Care.....	204
Washing.....	204
Waxing.....	205
Aluminum Wheels.....	206
Paint Touch-up.....	206
Interior Care.....	207
Carpeting.....	207
Floor Mats.....	207
Fabric.....	208
Vinyl.....	208
Leather.....	208
Rear Window.....	208
Seat Belts.....	208
Windows.....	209
Air Fresheners.....	209
Corrosion Protection.....	209
Body Repairs.....	211

Washing

Frequent washing helps preserve your car's beauty. Dirt and grit can scratch the paint, while tree sap and bird droppings can permanently ruin the finish.

Wash your car in a shady area, not in direct sunlight. If the car is parked in the sun, move it into the shade and let the exterior cool down before you start.

Only use the solvents and cleaners recommended in this Owner's Manual.

NOTICE

Chemical solvents and strong cleaners can damage the paint, metal, and plastic on your car.

- Rinse the car thoroughly with cool water to remove loose dirt.
- Fill a bucket with cool water. Mix in a mild detergent, such as dishwashing liquid or a product made especially for car washing.
- Wash the car, using the water and neutral detergent solution and sponge or soft cloth. Start at a top and work your way down. Rinse frequently.
- Check the body for road tar, tree sap, etc. Remove these stains with tar remover or turpentine. Rinse it off immediately so it does not harm the finish. Remember to re-wax these areas, even if the rest of

the car does not need waxing. Do not use harsh chemicals to remove stains from the convertible top or rear window. Use a mild detergent/water solution with a soft-bristle brush on the top, and with a soft cloth on the rear window.

- When you have washed and rinsed the whole exterior, dry it with a chamois or soft towel. Letting it air-dry will cause dulling and water spots. Make sure the top is completely dry before you fold it.

As you dry the car, inspect it for chips and scratches that could allow corrosion to start. Repair them with touch-up paint (see page 206).

Waxing

Always wash and dry the whole car before waxing it. You should wax your car, including the metal trim, whenever water sits on the surface in large patches. It should form into beads or droplets after waxing.

You should use a quality liquid or paste wax. Apply it according to the instructions on the container. In general, there are two types of products:

Waxes — A wax coats the finish and protects it from damage by exposure to sunlight, air pollution, etc. You should use a wax on your Honda when it is new.

Polishes — Polishes and cleaner/waxes can restore the shine to paint that has oxidized and lost some of its shine. They normally contain mild abrasives and solvents that remove the top layer of the finish. You should use a polish on your Honda if the finish does not have its original shine after using a wax.

Cleaning tar, insects, etc. with removers also takes off the wax. Remember to re-wax those areas, even if the rest of the car does not need waxing.

Aluminum Wheels

Clean your Acura's aluminum alloy wheels as you do the rest of the exterior. Wash them with the same solution, and rinse them thoroughly.

The wheels have a protective clear-coat that keeps the aluminum from corroding and tarnishing. Using harsh chemicals, including some commercial wheel cleaners, or stiff brushes can damage this clear-coat. Only use a mild detergent and soft brush or sponge to clean the wheels.

Paint Touch-up

Your dealer has touch-up paint to match your car's color. The color code is printed on a sticker on the driver's doorjamb. Take this code to your dealer so you are sure to get the correct color.

Inspect your car frequently for chips or scratches in the paint. Repair them right away to prevent corrosion of the metal underneath. Use the touch-up paint only on small chips and scratches. More extensive paint damage should be repaired by a professional.

Carpeting

Vacuum the carpeting frequently to remove dirt. Ground-in dirt will make the carpet wear out faster.

Periodically shampoo the carpet to keep it looking new. Use one of the foam-type carpet cleaners on the market. Follow the instructions that come with the cleaner, applying it with a sponge or soft brush. Keep the carpeting as dry as possible by not adding water to the foam.

Floor Mats

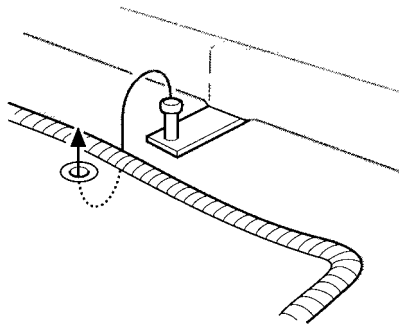

The Genuine Honda driver's floor mat that came with your car was designed to be hooked over the floor mat anchor. This keeps the floor mat from sliding forward and possibly interfering with the pedals.

If you remove the floor mat, make sure to re-anchor it when you put it back in your car.

If you replace it, use a genuine Honda floor mat that is designed to be used with the floor mat anchor in your car.

If you use a non-Honda floor mat in the driver's footwell, make sure it fits properly and that it can be used with the floor mat anchor.

Do not put additional floor mats on top of the anchored mat, otherwise the additional mats may slide forward and interfere with the pedals.

Fabric

Vacuum dirt and dust out of the material frequently. For general cleaning, use a solution of mild soap and lukewarm water, letting it air dry. To clean off stubborn spots, use a commercially-available fabric cleaner. Test it on a hidden area of the fabric first, to make sure it does not bleach or stain the fabric. Follow the instructions that come with the cleaner.

Vinyl

Remove dirt and dust with a vacuum cleaner. Wipe the vinyl with a soft cloth dampened in a solution of mild soap and water. Use the same solution with a soft-bristle brush on more difficult spots. You can also use commercially-available spray or foam-type vinyl cleaners.

Leather

Vacuum dirt and dust from the leather frequently. Pay particular attention to the pleats and seams. Clean the leather with a soft cloth dampened with clear water, then buff it with a clean, dry cloth. If further cleaning is needed, use a soap specifically for leather, such as saddle soap. Apply this soap with a damp, soft cloth. Wipe down and buff as described above.

Rear Window

Clean the rear window with either clean water or a mild detergent/water solution and a soft, damp cloth. Never use a brush or dry cloth, and do not use any harsh chemicals or abrasive cleaners. You will damage the window.

Polish the rear window periodically with a commercially available plastic polish made especially for convertible rear windows.

Seat Belts

If your seat belts get dirty, you can use a soft brush with a mixture of mild soap and warm water to clean them. Do not use bleach, dye, or cleaning solvents. They can weaken the belt material. Let the belts air-dry before you use the car.

Windows

Clean the windows, inside and out, with a commercially-available glass cleaner. You can also use a mixture of one part white vinegar to ten parts water. This will remove the haze that builds up on the inside of the windows. Use a soft cloth or paper towels to clean all glass and clear plastic surfaces.

Air Fresheners

If you want to use an air freshener/deodorizer in the interior of your car, it is best to use a solid type. Some liquid air fresheners contain chemicals that may cause parts of the interior trim and fabric to crack or discolor.

If you use a liquid air freshener, make sure you fasten it securely so it does not spill as you drive.

Corrosion Protection

Two factors normally contribute to causing corrosion in your car:

1. Moisture trapped in body cavities. Dirt and road salt that collects in hollows on the underside of the car stays damp, promoting corrosion in that area.
2. Removal of paint and protective coatings from the exterior and underside of the car.

Many corrosion-preventive measures are built into your Honda. You can help keep your car from corroding by performing some simple periodic maintenance:

- Repair chips and scratches in the paint as soon as you discover them.
 - Inspect and clean out the drain holes in the bottom of the doors and body.
 - Check the floor coverings for dampness. Carpeting and floor mats may remain damp for a long time, especially in winter. This dampness can eventually cause the floor panels to corrode.
- Use a high-pressure spray to clean the underside of your car. This is especially important in areas that use road salt in winter. It is also a good idea in humid climates and areas subject to salt air. Be careful of the ABS wheel sensors and wiring at each wheel.
 - Have the corrosion-preventive coatings on the underside of your car inspected and repaired periodically.

Body repairs can affect your car's resistance to corrosion. If your car needs repairs after a collision, pay close attention to the parts used in the repair and the quality of the work.

Make sure the repair facility uses genuine Honda replacement body parts. Some companies make sheet metal pieces that seem to duplicate the original Honda body parts, but are actually inferior in fit, finish, and corrosion resistance. Once installed, they do not give the same high-quality appearance.

When reporting your collision to the insurance company, tell them you want genuine Honda parts used in the repair. Although most insurers recognize the quality of original parts, some may try to specify that the repairs be done with other available parts. You should investigate this before any repairs have begun.

Take your car to your authorized Honda dealer for inspection after the repairs are completed. Your dealer can make sure that quality materials were used, and that corrosion-preventive coatings were applied to all repaired and replaced parts.

This section covers the more-common problems that motorists experience with their vehicles. It gives you information about how to safely evaluate the problem and what to do to correct it. If the problem has stranded you on the side of the road, you may be able to get going again. If not, you will also find instructions on getting your car towed.

Compact Spare Tire.....	214
Changing a Flat Tire	215
If Your Engine Won't Start.....	220
Nothing Happens or the Starter Motor Operates Very Slowly.....	220
The Starter Operates Normally.....	221
Jump Starting.....	222
If Your Engine Overheats.....	225
Low Oil Pressure Indicator.....	228
Charging System Indicator.....	229
Malfunction Indicator Lamp	230
Brake System Indicator.....	232
Closing the Convertible Top.....	233
Fuses.....	234
Checking and Replacing.....	235
If Your Car Gets Stuck.....	239
Emergency Towing.....	241

Compact Spare Tire

Your car has a compact spare tire that takes up less space. Use this spare tire as a temporary replacement only. Get your regular tire repaired or replaced and put it back on your car as soon as you can.

Check the inflation pressure of the compact spare tire every time you check the other tires. It should be inflated to:
60 psi (420 kPa , 4.2 kgf/cm²)

Follow these precautions whenever you are using the compact spare tire:

- Do not exceed 50 mph (80 km/h) under any circumstances.
- This tire gives a harsher ride and less traction on some road surfaces than the regular tire. Use greater caution while driving on this tire.
- Do not mount snow chains on the compact spare.
- The wheel of the compact spare tire is designed especially to fit your car. Do not use your spare tire on another vehicle unless it is the same make and model.

INDICATOR LOCATION MARK

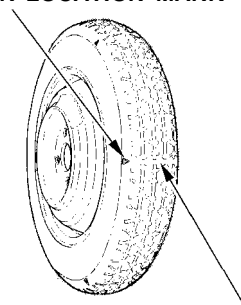

TREAD WEAR INDICATOR BAR

The compact spare tire has a shorter tread life than a regular tire. Replace it when you can see the tread wear indicator bars. The replacement should be the same size and design tire, mounted on the same wheel. The compact spare tire is not designed to be mounted on a regular wheel, and the compact wheel is not designed for mounting a regular tire.

If you have a flat tire while driving, stop in a safe place to change it. Stopping in traffic or on the shoulder of a busy road is dangerous. Drive slowly along the shoulder until you get to an exit or an area to stop that is far away from the traffic lanes.

The car can easily roll off the jack, seriously injuring anyone underneath.

Follow the directions for changing a tire exactly, and never get under the car when it is supported only by the jack.

The compact spare tire is smaller than a standard tire, which will affect the vehicle's handling. Drive cautiously when this spare is mounted on your vehicle.

The size difference may also cause damage to the rear differential, so do not mount the compact spare on the rear. If either rear tire goes flat, remove the front tire on that same side, mount the compact spare tire on the front, then mount the front tire on the rear.

1. Park the car on firm, level, non-slippery ground away from traffic. Put the transmission in Reverse. Apply the parking brake.
2. Turn on the hazard warning lights and turn the ignition switch to LOCK (0). Have your passenger get out of the car while you change the tire.

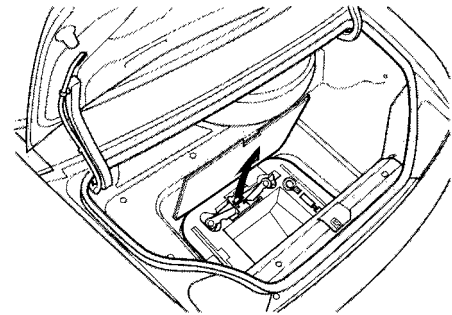

3. Open the trunk. Lift up the tool box lid and take the jack, wheel wrench and extension out of the tool box.

NOTICE

Use the jack that came on your car. If you try to raise another car by this jack or use another jack to raise your car, the car or jack can be damaged.

CONTINUED

Changing a Flat Tire

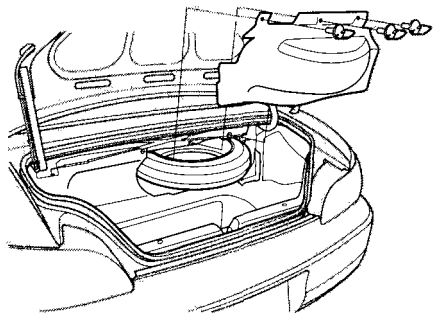

4. Remove the three clips holding the spare tire cover by pulling straight up on the rings. Remove the spare tire cover.

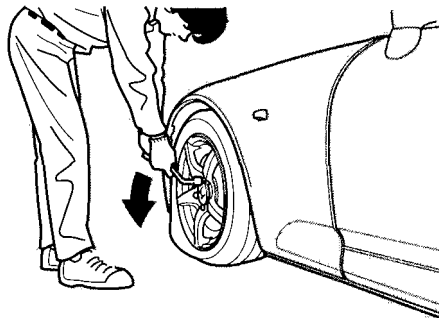

5. Unscrew the wing bolt and take the spare tire out of the spare tire shelf.
6. Loosen the five wheel nuts $1/2$ turn with the wheel wrench.

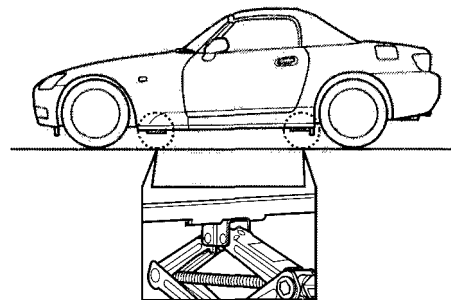

7. Locate the jacking point nearest the tire you need to change. It is pointed to by an arrow molded into the underside of the body. Place the jack under the jacking point. Turn the end bracket clockwise until the top of the jack contacts the jacking point. Make sure the jacking point tab is resting in the jack notch.

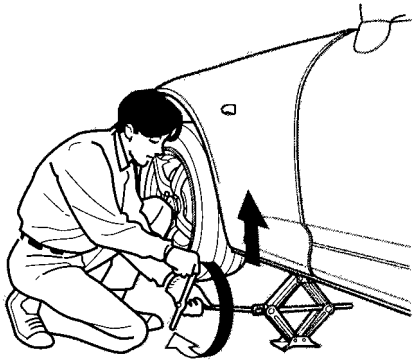

8. Use the extension and wheel wrench as shown to raise the car until the flat tire is off the ground.

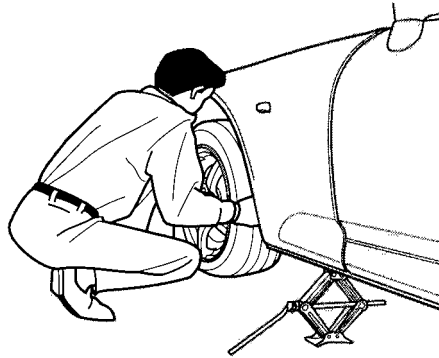

9. Remove the wheel nuts and flat tire. Temporarily place the flat tire on the ground with the outside surface of the wheel facing up. Placing the wheel face down could mar its finish.

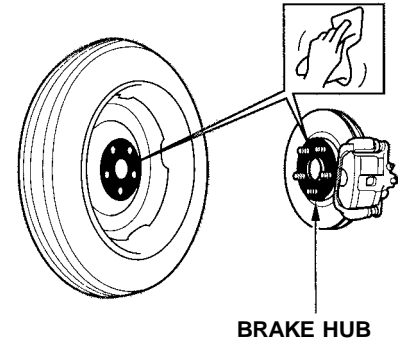

10. Before mounting the spare tire, wipe any dirt off the mounting surface of the wheel and hub with a clean cloth. Wipe the hub carefully, it may be hot from driving.

CONTINUED

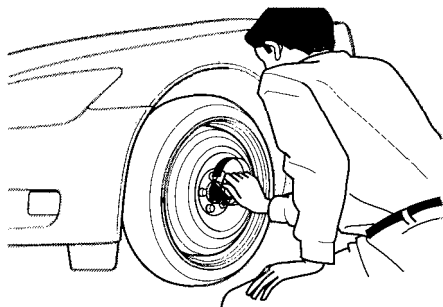

11. Put on the spare tire. Put the wheel nuts back on finger-tight, then tighten them in a crisscross pattern with the wheel wrench until the wheel is firmly against the hub. Do not try to tighten them fully.

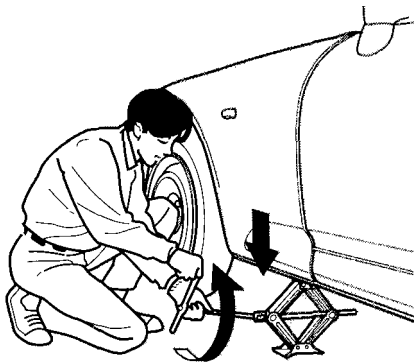

12. Lower the car to the ground and remove the jack.

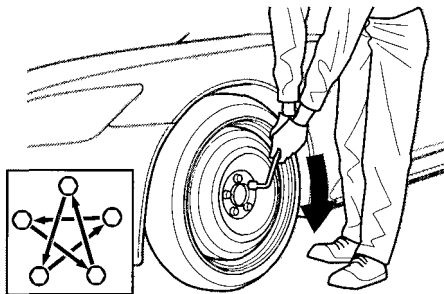

13. Tighten the wheel nuts securely in the same crisscross pattern. Have the wheel nut torque checked at the nearest automotive service facility.
Tighten the wheel nuts to:
80 lbf.ft(108 N.m, 11 kgf.m)

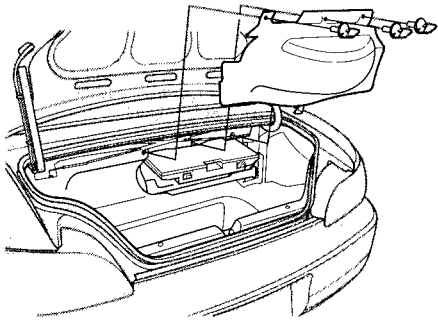

14. Remove the tool box from the trunk well and replace the jack, wheel wrench and extension in the tool box.
15. Place the tool box into the spare tire shelf in the trunk.

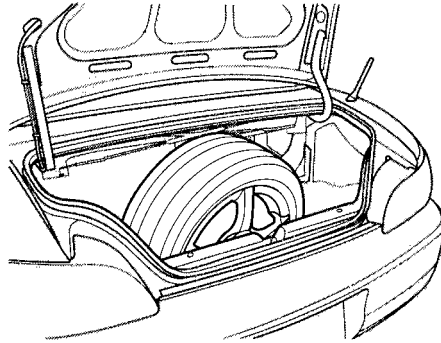

16. Replace the spare tire cover. Secure it with the three clips. Push each clip down securely, and pivot the ring down flat.
17. Put the flat tire in the trunk well vertically as shown.

If Your Engine Won't Start

Diagnosing why your engine won't start falls into two areas, depending on what you hear when you press the ENGINE START button.

- You hear nothing, or almost nothing. The engine's starter motor does not operate at all, or operates very slowly.
- You can hear the starter motor operating normally, or the starter motor sounds like it is spinning faster than normal, but the engine does not start up and run.

Nothing Happens or the Starter Motor Operates Very Slowly

When you press the ENGINE START button, you do not hear the normal noise of the engine trying to start. You may hear a clicking sound or series of clicks, or nothing at all. Check these things:

- Your car has the Immobilizer System. You should use a properly-coded master or valet key to start the engine (see page 59). A key that is not properly coded will cause the immobilizer system indicator in the dash panel to blink rapidly.

- Turn the ignition switch to ON (II). Turn on the headlights and check their brightness. If the headlights are very dim or don't light at all, the battery is discharged. See **Jump Starting** on page 222.
- Press the ENGINE START button, then release it. If the headlights do not dim, check the condition of the fuses. If the fuses are OK, there is probably something wrong with the electrical circuit for the ignition switch or starter motor. You will need a qualified technician to determine the problem. (See **Emergency Towing** on page 241.)

If the headlights dim noticeably or go out when you try to start the engine, either the battery is discharged or the connections are corroded. Check the condition of the battery and terminal connections (see page 177). You can then try jump starting the car from a booster battery (see page 222).

The Starter Operates Normally

In this case, the starter motor's speed sounds normal, or even faster than normal, when you press the ENGINE START button, but the engine does not run.

- Are you using the proper starting procedure? Refer to **Starting the Engine** on page 131.
- Do you have fuel? Turn the ignition switch to ON (II) for a minute and watch the fuel gauge. The low fuel level warning light may not be working, so you were not reminded to fill the tank.

- There may be an electrical problem, such as no power to the fuel pump. Check all the fuses (see page 235).

If you find nothing wrong, you will need a qualified technician to find the problem. See **Emergency Towing** on page 241.

If your car's battery has run down, you may be able to start the engine by using a booster battery. Although this seems like a simple procedure, you should take several precautions.

A battery can explode if you do not follow the correct procedure, seriously injuring anyone nearby.

Keep all sparks, open flames, and smoking materials away from the battery.

To jump start your car, follow these directions closely:

1. Open the hood and check the physical condition of the battery (see page 177). In very cold weather, check the condition of the electrolyte. If it seems slushy or like ice, do not try jump starting until it thaws.

NOTICE

If a battery sits in extreme cold, the electrolyte inside can freeze. Attempting to jump start with a frozen battery can cause it to rupture.

2. Turn off all the electrical accessories: heater, A/C, stereo system, lights, etc.
Put the transmission in Neutral and set the parking brake.

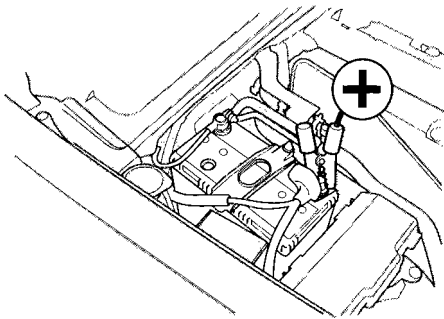

3. Connect one jumper cable to the positive (+) terminal on your Honda's battery. Connect the other end to the positive (+) terminal on the booster battery.

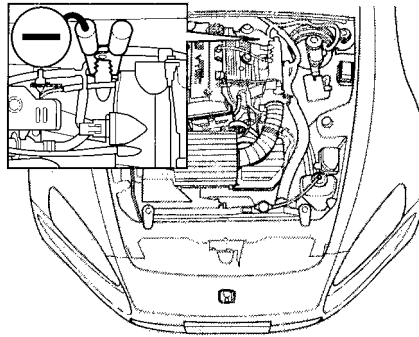

4. Connect the second jumper cable to the negative (-) terminal on the booster battery. Connect the other end to the metal projection near the intake manifold as shown in the illustration. Do not connect this jumper cable to any other part of the engine.

5. If the booster battery is in another vehicle, have an assistant start that vehicle and run it at a fast idle.

CONTINUED

Jump Starting

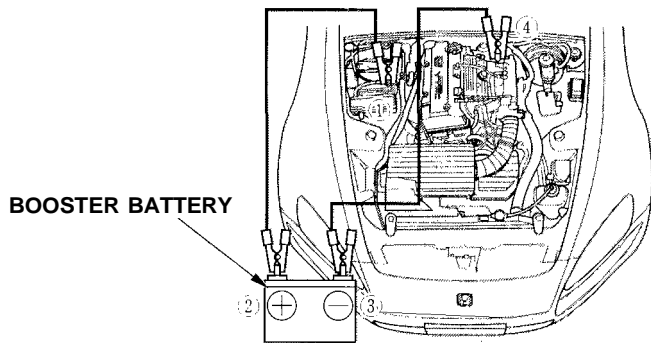

6. Start your car. If the starter motor still operates slowly, check the jumper cable connections to make sure they have good metal-to-metal contact.

7. Once your car is running, disconnect the negative cable from your car, then from the booster battery. Disconnect the positive cable from your car, then the booster battery.

Keep the ends of the jumper cables away from each other and any metal on the car until all are disconnected. Otherwise, you may cause an electrical short.

The reading on your car's temperature gauge should stay in the midrange under most conditions. It may go higher if you are driving up a long steep hill on a very hot day. If it climbs to the red mark, you should determine the reason.

NOTICE

Driving with the temperature gauge reading at the red mark can cause serious damage to your engine.

Your car can overheat for several reasons, such as lack of coolant or a mechanical problem. The only indication may be the temperature gauge climbing to or above the red mark. Or you may see steam or spray coming from under the car or engine cover. In either case, you should take immediate action.

Steam and spray from an overheated engine can seriously scald you.

Do not open the hood if steam is coming out.

1. Safely pull to the side of the road. Put the transmission in Neutral and set the parking brake. Turn off the heating and cooling system and all other accessories. Turn on the hazard warning indicators.
2. If you see steam and/or spray coming from under the hood, turn off the engine.
3. If you do not see steam or spray, leave the engine running and watch the temperature gauge. If the high heat is due to overloading (climbing a long, steep hill on a hot day with the A/C running, for example), the engine should start to cool down almost immediately. If it does, wait until the temperature gauge comes down to the midpoint then continue driving.
4. If the temperature gauge stays at the red mark, turn off the engine.
5. Wait until you see no more signs of steam or spray, then open the hood.

CONTINUED

If Your Engine Overheats

6. Look for any obvious coolant leaks, such as a split radiator hose. Everything is still extremely hot, so use caution. If you find a leak, it must be repaired before you continue driving (see **Emergency Towing** on page 241).

Removing the radiator cap while the engine is hot can cause the coolant to spray out, seriously scalding you.

Always let the engine and radiator cool down before removing the radiator cap.

7. If you don't find an obvious leak, check the coolant level in the radiator reserve tank (see page 120). If the level is below the MIN mark, add coolant to halfway between the MIN and MAX marks.
8. If there was no coolant in the reserve tank, you may also have to add coolant to the radiator. Let the engine cool down until the reading reaches the middle of the temperature gauge, or lower, before checking the radiator.

9. Using gloves or a large heavy cloth, turn the radiator cap counterclockwise, without pushing down, to the first stop. This releases any remaining pressure in the cooling system. After the pressure releases, push down on the cap and turn it until it comes off.

10. Start the engine and set the temperature control dial to maximum. Add coolant to the radiator up to the base of the filler neck. If you do not have the proper coolant mixture available, you can add plain water. Remember to have the cooling system drained and refilled with the proper mixture as soon as you can.
11. Put the radiator cap back on tightly. Run the engine and watch the temperature gauge. If it goes back to the red mark, the engine needs repair. (See **Emergency Towing** on page [241](#).)
12. If the temperature stays normal, check the coolant level in the radiator reserve tank. If it has gone down, add coolant to the MAX mark. Put the cap back on tightly.

LOW OIL PRESSURE INDICATOR

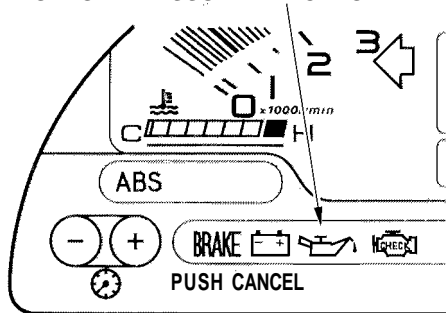

This indicator should light when the ignition switch is ON (II), and go out after the engine starts. It should never come on when the engine is running. If it starts flashing, it indicates that the oil pressure dropped very low for a moment, then recovered. If the indicator stays on with the engine running, it shows that the engine has lost oil pressure and serious engine damage is possible. In either case, you should take immediate action.

NOTICE

Running the engine with low oil pressure can cause serious mechanical damage almost immediately. Turn off the engine as soon as you can safely get the car stopped.

1. Safely pull off the road and shut off the engine. Turn on the hazard warning indicators.
2. Let the car sit for a minute. Open the hood and check the oil level (see page 119). Although oil level and oil pressure are not directly connected, an engine that is very low on oil can lose pressure during cornering and other driving maneuvers.
3. If necessary, add oil to bring the level back to the full mark on the dipstick (see page 157).

4. Start the engine and watch the oil pressure indicator. If the light does not go out within ten seconds, turn off the engine. There is a mechanical problem that needs to be repaired before you can continue driving. (See **Emergency Towing** on page 241.)

CHARGING SYSTEM INDICATOR

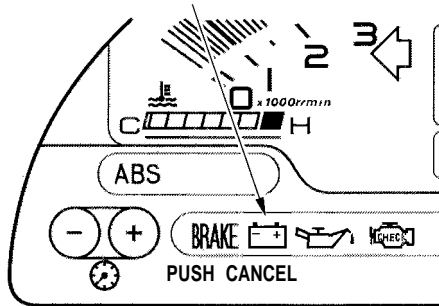

This indicator should come on when the ignition switch is ON (II), and go out after the engine starts. If it comes on brightly when the engine is running, it indicates that the charging system has stopped charging the battery.

Immediately turn off all electrical accessories: radio, heater, A/C, cruise control, etc. Try not to use other electrically-operated controls such as the power windows. Keep the engine running and take extra care not to stall it. Starting the engine will discharge the battery rapidly.

By eliminating as much of the electrical load as possible, you can drive several miles (kilometers) before the battery is too discharged to keep the engine running. Drive to a service station or garage where you can get technical assistance.

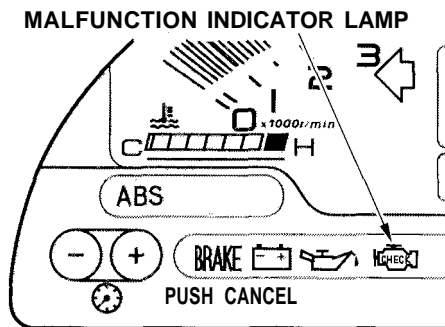

This indicator comes on for a few seconds when you turn the ignition switch ON (II). If it comes on at any other time, it indicates one of the engine's emissions control systems may have a problem. Even though you may feel no difference in your car's performance, it can reduce your fuel economy and cause your car to put out excessive emissions. Continued operation may cause serious damage.

If you have recently refueled your car, the cause of this indicator coming on could be a loose or missing fuel fill cap. Check the cap and tighten it until it clicks several times. Replace the fuel fill cap if it is missing. Tightening the cap will not make the indicator turn off immediately; it takes three driving trips.

If the indicator remains on past three driving trips, or the fuel cap was not loose or missing, have the car checked by the dealer as soon as possible. Drive moderately until the dealer has inspected the problem. Avoid full-throttle acceleration and driving at high speed.

You should also have the dealer inspect your car if this indicator comes on repeatedly, even though it may turn off as you continue driving.

NOTICE

If you keep driving with the malfunction indicator lamp on, you can damage your car's emissions controls and engine. Those repairs may not be covered by your car's warranties.

Readiness Codes

Your car has certain "readiness codes" that are part of the on-board diagnostics for the emissions systems. In some states, part of the emissions testing is to make sure these codes are set. If they are not set, the test cannot be completed.

If your car's battery has been disconnected or gone dead, these codes are erased. It takes several days of driving under various conditions to set the codes again.

If possible, do not take your car for a state emissions test until the readiness codes are set. See [State Emissions Testing](#) on pages [255](#) and [256](#).

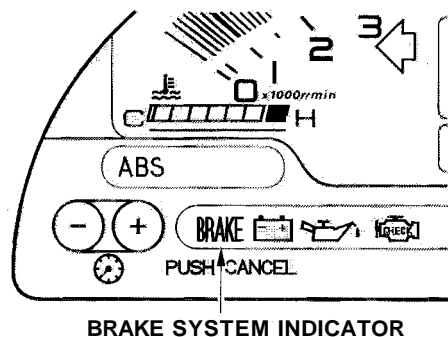

The Brake System Indicator normally comes on when you turn the ignition switch ON (II). It is a reminder to check the parking brake. It comes on and stays lit if you do not fully release the parking brake.

If it comes on at any other time, it indicates a problem with the car's brake system. In most cases, the problem is a low fluid level in the brake fluid reservoir. Press lightly on the brake pedal to see if it feels normal. If it does, check the brake fluid level the next time you stop at a service station (see page 170). If the fluid level is low, take the car to your dealer and have the brake system inspected for leaks or worn brake pads.

However, if the brake pedal does not feel normal, you should take immediate action. Because of the brake system's dual-circuit design, a problem in one part of the system will still give you braking at two wheels. You will feel the brake pedal go down much farther before the car begins to slow down, and you will have to press harder on the pedal. The distance needed to stop will be much longer.

Slow down by shifting to a lower gear, and pull to the side of the road when it is safe. Because of the longer distance needed to stop, it is hazardous to drive the car. You should have it towed, and repaired as soon as possible.

If you must drive the car a short distance in this condition, drive slowly and cautiously.

If the electric motor will not close the convertible top, do the following.

1. Check the fuse for the convertible top motor (see page [235](#)). If the fuse is blown, replace it with one of the same or lower rating.
2. Try closing the convertible top. If the new fuse blows immediately or the convertible top still does not operate, you can close the convertible top manually.

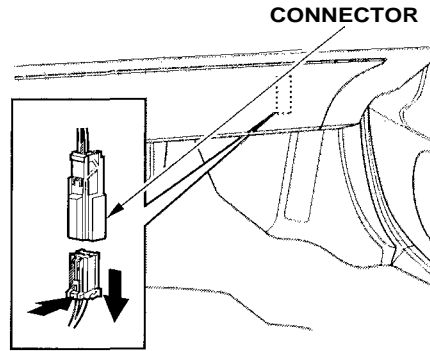

3. Locate the electrical connector for the convertible top motor. It is under the lower corner of the dashboard on the passenger's side. Disconnect the connector by pushing the tab and pulling the connector down.

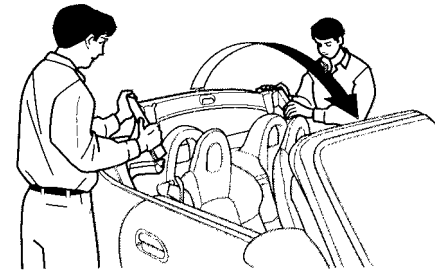

4. Holding each corner of the convertible top, raise the top and push it forward as far as it will go.
5. Follow steps 5 through 7 of the closing procedure on page [76](#).

Fuses

All the electrical circuits in your car have fuses to protect them from a short circuit or overload. These fuses are located in three fuse boxes.

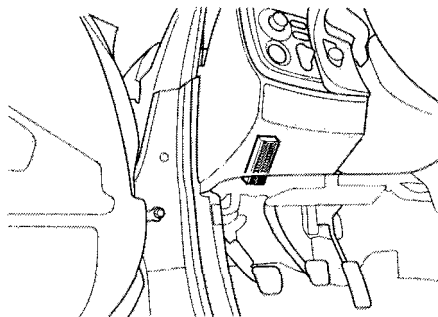

The interior fuse box is underneath the dashboard on the driver's side.

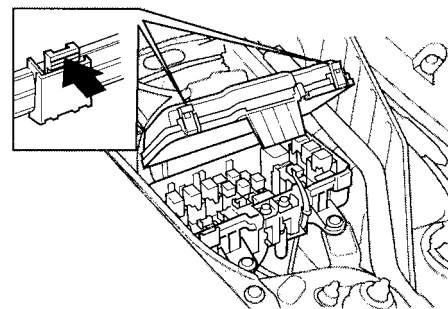

There are two under-hood fuse boxes in the engine compartment.

The main fuse box is located on the passenger's side near the battery. To open it, push the two tabs as shown.

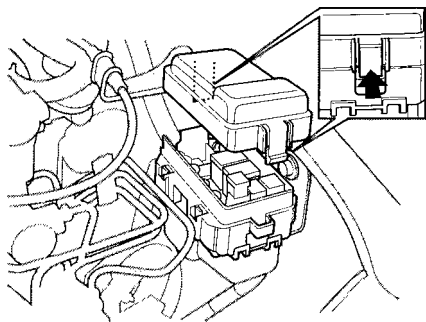

The auxiliary fuse box is located on the driver's side near the brake fluid reservoir. To open it, push the tab on each side and remove the lid.

Checking and Replacing Fuses

If something electrical in your car stops working, the first thing you should check for is a blown fuse. Determine from the chart on pages [237](#) and [238](#), or the diagram on the fuse box lid, which fuse or fuses control that component. Check those fuses first, but check all the fuses before deciding that a blown fuse is not the cause. Replace any blown fuses and check the component's operation.

1. Turn the ignition switch to LOCK (0). Make sure the headlights and all other accessories are off.
2. Remove the cover from the fuse box.

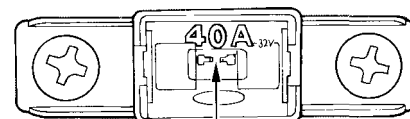

BLOWN

3. Check each of the large fuses in the under-hood fuse box by looking through the top at the wire inside. Removing these fuses requires a Phillips-head screwdriver.

CONTINUED

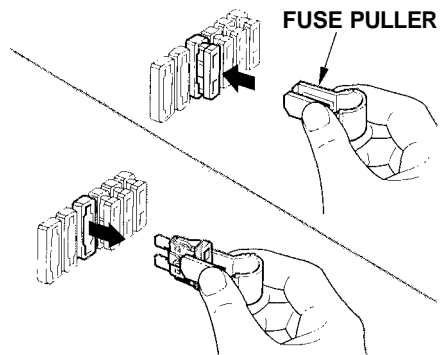

4. Check the smaller fuses by pulling out the fuse with the fuse puller provided in the interior fuse box.

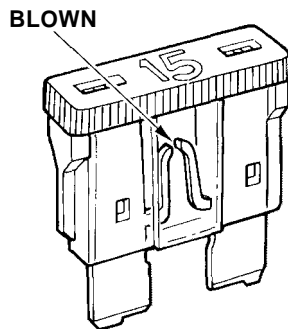

5. Look for a burned wire inside the fuse. If it is burned, replace it with one of the spare fuses of the same rating or lower.

If you cannot drive the vehicle without fixing the problem, and you do not have a spare fuse, take a fuse of the same rating or a lower rating from one of the other circuits. Make sure you can do without that circuit temporarily (such as the accessory power socket or radio).

If you replace the blown fuse with a spare fuse that has a lower rating, it might blow out again. This does not indicate anything wrong. Replace the fuse with one of the correct rating as soon as you can.

NOTICE

Replacing a fuse with one that has a higher rating greatly increases the chances of damaging the electrical system. If you do not have a replacement fuse with the proper rating for the circuit, install one with a lower rating.

6. If the replacement fuse of the same rating blows in a short time, there is probably a serious electrical problem in your car. Leave the blown fuse in that circuit and have your car checked by a qualified mechanic.

INTERIOR FUSE BOX

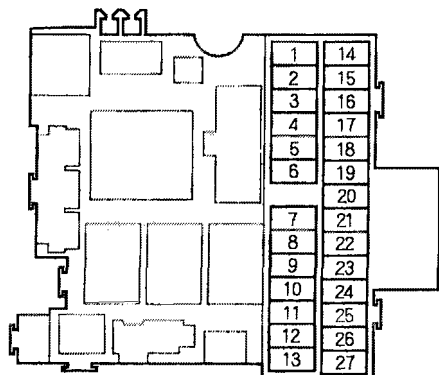

No.	Amps.	Circuits Protected
1	7.5 A	Windshield Wiper, Auto Stop Signal
2	15 A	Washer Motor
3	—	Not used
4	—	Not used
5	10 A	Accessory Socket
6	20 A	Windshield Wiper
7	7.5 A	Turn signal Light
8	15 A	ACG
9	7.5 A	Instrument Light, Back-up Lights
10	15 A	Ignition Coil
11	7.5 A	Engine Start
12	15 A	Fuel Pump, SRS
13	10 A	SRS

No.	Amps.	Circuits Protected
14	10 A	Daytime Running Lights*
15	10 A	Keyless Entry
16	7.5 A	Back-up
17	7.5 A	Interior Light
18	10 A	Small Lights
19	15 A	Radio
20	7.5 A	Starter Signal
21	7.5 A	Heater Control, Cooling Fan Relay
22	7.5 A	Power Mirrors
23	20 A	Right Power Window
24	20 A	Left Power Window
25	—	Not used
26	—	Not used
27	—	Not used

* : Canadian Model

CONTINUED

UNDER-HOOD FUSE BOXES (MAIN FUSE BOX)

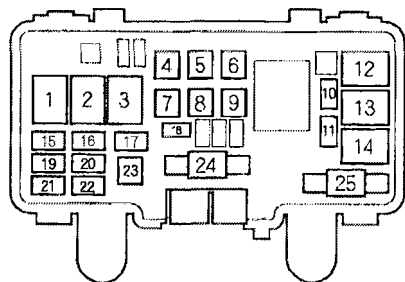

No.	Amps.	Circuits Protected
1	—	Lighting 1 Relay
2	—	Lighting 2 Relay
3	—	Horn Relay
4	40 A	Power Window Motor
5	20 A	Right Roof Motor
6	—	Not used
7	30 A	Back Up ACC
8	20 A	Left Roof Motor
9	40 A	Heater Motor
10	20 A	Condenser Fan
11	—	Not used
12	—	Condenser Fan Relay
13	—	Cooling Fan Relay

No.	Amps.	Circuits Protected
14	—	Magnetic Clutch Relay
15	20 A	Right Headlight
16	15 A	ACG S
17	10 A	Hazard Warning Lights
18	20 A	Cooling Fan
19	—	Not used
20	10 A	Stop
21	20 A	Left Headlight
22	20 A	ABS F/S
23	30 A	ABS Motor
24	100 A	Battery
25	40 A	IG1 Main

(AUXILIARY FUSE BOX)

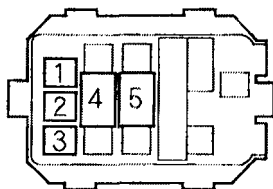

No.	Amps.	Circuits Protected
1	—	Not used
2	—	Not used
3	—	Not used
4	70 A	EPS
5	60 A	Air Pump

If your car gets stuck in sand, mud, or snow, call a towing service to pull it out (see page [241](#)).

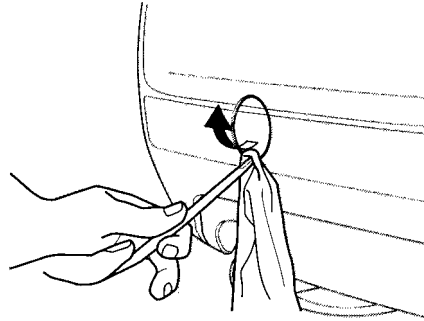

For very short distances, such as freeing the car, you can use the detachable towing hook that mounts on the anchors in the front and rear bumpers.

To use the towing hook:

1. Remove the cover from the bumper.

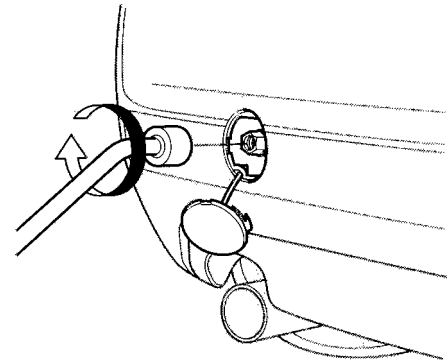

2. Remove the towing hook, hook extension and wheel wrench from the tool box.
3. Using the wheel wrench, fasten the extension into the bolt hole in the anchor.

CONTINUED

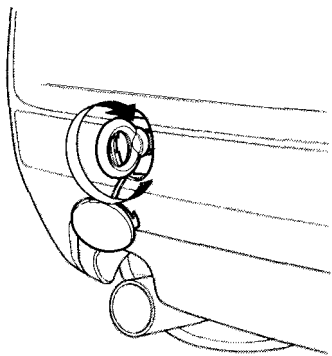

4. Screw the towing hook into the extension and tighten it securely by hand.

NOTICE

To avoid damage to your car, use the towing hook for straight, flat ground towing only. Do not tow at an angle. The tow hook should not be used to tow t/ie vehicle onto a flat bed. Do not use it as a tie down.

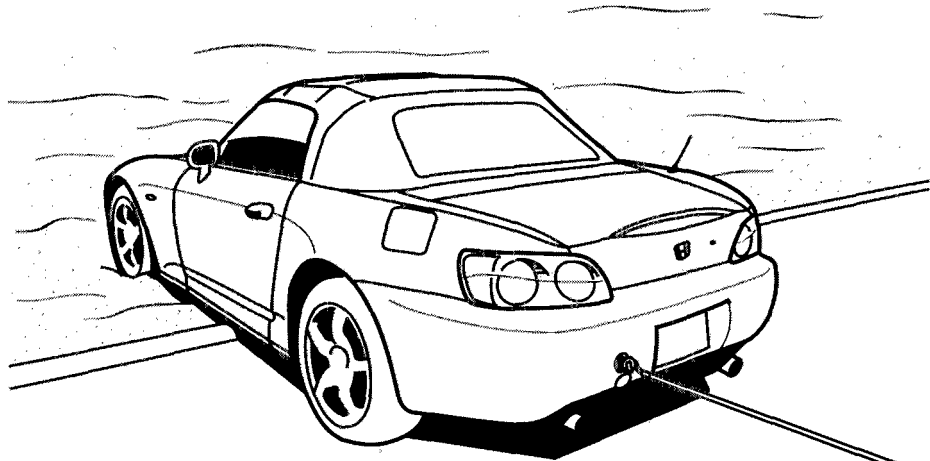

If your car needs to be towed, call a professional towing service or, if you belong to one, an organization that provides roadside assistance. Never tow your car behind another vehicle with just a rope or chain. It is very dangerous.

There are three popular types of professional towing equipment.

Flat-bed Equipment—The operator loads your vehicle on the back of a truck. **This is the only way your S2000 should be transported.** When you contact the towing agency, inform them that you have an S2000 and that a flat-bed is required.

Wheel Lift Equipment—The tow truck uses two pivoting arms that go under the tires (front or rear) and lift them off the ground. The other two tires remain on the ground. Because the S2000 sits so low, the body could come in contact with the ground and be damaged. **This method of towing is unacceptable.**

Emergency Towing

Sling-type Equipment — The tow truck uses metal cables with hooks on the ends. These hooks go around parts of the frame or suspension and the cables lift that end of the car off the ground. Your car's suspension and body can be seriously damaged. **This method of towing is unacceptable.**

The diagrams in this section give you the dimensions and capacities of your Honda, and the locations of the identification numbers. It also includes information you should know about your vehicle's tires and emissions control systems.

Identification Numbers.....	244	Oxygenated Fuels.....	250
Specifications.....	246	Driving in Foreign Countries.....	251
DOT Tire Quality Grading (U.S. Vehicles).....	248	Emissions Controls.....	252
Treadwear.....	248	The Clean Air Act.....	252
Traction.....	248	Crankcase Emissions Control System.....	252
Temperature.....	249	Evaporative Emissions Control System.....	252
		Exhaust Emissions Controls....	253
		PGM-FI System.....	253
		Ignition Timing Control System.....	253
		Secondary Air Injection System.....	253
		Three Way Catalytic Converter.....	253
		Replacement Parts.....	253
		Three Way Catalytic Converter...	254
		State Emission Testing.....	255

Identification Numbers

Your car has several identifying numbers located in various places.

The Vehicle Identification Number (VIN) is the 17-digit number your Honda dealer uses to register your car for warranty purposes. It is also necessary for licensing and insuring your car. The easiest place to find the VIN is on a plate fastened to the top of the dashboard. You can see it by looking through the windshield on the driver's side. It is also on the Certification label attached to the driver's doorjamb, and is stamped on the engine compartment bulkhead. The VIN is also provided in bar code on the Certification label.

VEHICLE IDENTIFICATION NUMBER

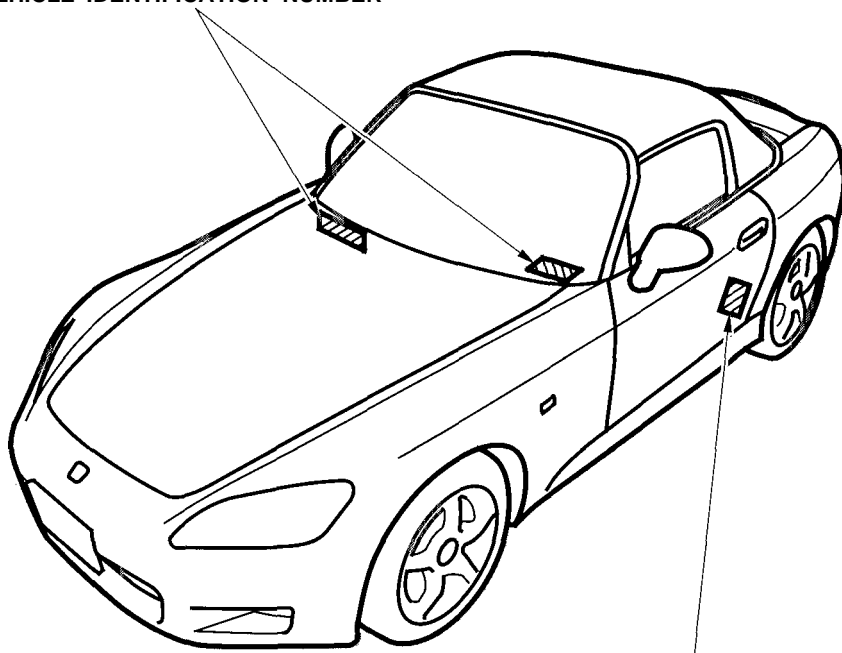

CERTIFICATION LABEL

The Engine Number is stamped on the left front corner of the engine block.

The Transmission Number is on a label underneath the transmission.

TRANSMISSION NUMBER

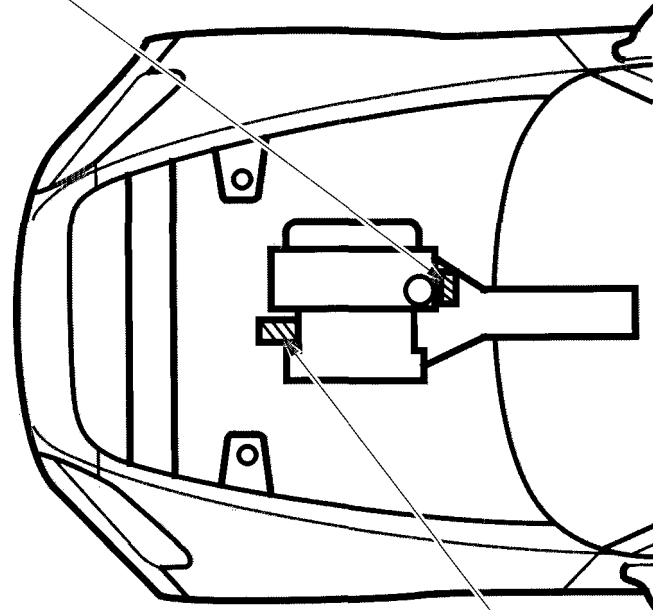

ENGINE NUMBER

Specifications

Dimensions

Length	162.0 in (4,115 mm)
Width	68.9 in (1,750 mm)
Height	50.6 in (1,285 mm)
Wheelbase	94.5 in (2,400 mm)
Track	57.9 in (1,470 mm)
Front	
Rear	59.4 in (1,510 mm)

Weights

Gross vehicle weight rating	See the certification label attached to the driver's doorjamb.
-----------------------------	--

Engine

Type	Water cooled 4-stroke DOHC VTEC 4-cylinder gasoline engine
Bore x Stroke	3.43 x 3.31 in (87.0 x 84.0 mm)
Displacement	121.8 cu-in (1,997 cm ³)
Compression ratio	11.0 : 1
Spark plugs	See spark plug maintenance section page 176

Capacities

Fuel tank		13.2 US gal (50 ℓ , 11.0 Imp gal)
Engine coolant		
Change ^{*1}		1.72 US gal (6.5 ℓ , 1.43 Imp gal)
Total		2.01 US gal (7.6 ℓ , 1.67 Imp gal)
Engine oil		
Change ^{*2}		
Including filter		5.1 US qt (4.8 ℓ , 4.2 Imp qt)
Without filter		4.8 US qt (4.5 ℓ , 4.0 Imp qt)
Total		5.9 US qt (5.6 ℓ , 4.9 Imp qt)
Manual transmission fluid		
Change		1.6 US qt (1.5 ℓ , 1.3 Imp qt)
Total		1.7 US qt (1.6 ℓ , 1.4 Imp qt)
Differential oil		
Change		0.78 US qt (0.74 ℓ , 0.65 Imp qt)
Total		0.81 US qt (0.77 ℓ , 0.68 Imp qt)
Windshield washer reservoir		
U.S. Cars		2.7 US qt (2.6 ℓ , 2.3 Imp qt)
Canadian Cars		4.4 US qt (4.2 ℓ , 3.7 Imp qt)

* 1 : Including the coolant in the reserve tank and that remaining in the engine.

Reserve tank capacity:
0.16 US gal (0.6ℓ , 0.13 Imp gal)

* 2 : Excluding the oil remaining in the engine.

Lights

Headlights	High	12 V – 55 W
Daytime running lights		12 V – 55 W(H1)
Front turn signal lights		12 V – 21 W
Rear turn signal lights		12 V – 21 W
Stop/Taillights		12 V – 21 W/5 W
Side marker lights	Front	12 V – 5 W
	Rear	12 V – 5 W
Back-up lights		12 V – 21 W
License plate lights		12 V – 5 W
Interior light		12 V – 5 W
Trunk light		12 V – 5 W

Air conditioning

Refrigerant type	HFC-134a (R-134a)
Charge quantity	19.4 – 21.2 oz (550 – 600 g)
Lubricant type	SP-10

Battery

Capacity	12 V – 36 AH/5 HR
----------	-------------------

Fuses

Under-hood	See page 238 or the fuse box cover.
Interior	See page 237 or the fuse label attached to the inside of the fuse box door under the dashboard.

Alignment

Toe	Front	0.00 in (0.0 mm)
	Rear	in 0.24 in (6.0 mm)
Camber	Front	– 0°30'
	Rear	– 1°30'
Caster	Front	6°

Tires

Size	Front	205/55R16 89W
	Rear	225/50R16 92W
	Spare Tire	T125/70D16 96M
Pressure	Front	32 psi (220 kPa , 2.2 kgf/cm ²)
	Rear	32 psi (220 kPa , 2.2 kgf/cm ²)
	Spare Tire	60 psi (420 kPa , 4.2 kgf/cm ²)

DOT Tire Quality Grading (U.S. Vehicles)

The tires on your vehicle meet all U.S. Federal Safety Requirements. All tires are also graded for treadwear, traction, and temperature performance according to Department of Transportation (DOT) standards. The following explains these gradings.

Uniform Tire Quality Grading

Quality grades can be found where applicable on the tire sidewall between the tread shoulder and the maximum section width. For example:

Treadwear 200

Traction AA

Temperature A

DOT Quality Grades

All passenger car tires must conform to Federal Safety Requirements in addition to these grades.

Treadwear

The treadwear grade is a comparative rating based on the wear rate of the tire when tested under controlled conditions on a specified government test course. For example, a tire graded 150 would wear one and one-half (1 1/2) times as well on the government course as a tire graded 100. The relative performance of tires depends upon the actual conditions of their use, however, and may depart significantly from the norm due to variations in driving habits, service practices and differences in road characteristics and climate.

Traction — AA, A, B, C

The traction grades, from highest to lowest, are AA, A, B, and C. Those grades represent the tire's ability to stop on wet pavement as measured under controlled conditions on specified government test surfaces of asphalt and concrete. A tire marked C may have poor traction performance.

Warning: The traction grade assigned to this tire is based on straight-ahead braking traction tests, and does not include acceleration, cornering, hydroplaning, or peak traction characteristics.

Temperature — A, B, C

The temperature grades are A (the highest), B, and C, representing the tire's resistance to the generation of heat and its ability to dissipate heat when tested under controlled conditions on a specified indoor laboratory test wheel. Sustained high temperature can cause the material of the tire to degenerate and reduce tire life, and excessive temperature can lead to sudden tire failure. The grade C corresponds to a level of performance which all passenger car tires must meet under the Federal Motor Vehicle Safety Standard No. 109. Grades B and A represent higher levels of performance on the laboratory test wheel than the minimum required by law.

Warning: The temperature grade for this tire is established for a tire that is properly inflated and not overloaded. Excessive speed, underinflation, or excessive loading, either separately or in combination, can cause heat buildup and possible tire failure.

Oxygenated Fuels

Some conventional gasolines are being blended with alcohol or an ether compound. These gasolines are collectively referred to as oxygenated fuels. To meet clean air standards, some areas of the United States and Canada use oxygenated fuels to help reduce emissions.

If you use an oxygenated fuel, be sure it is unleaded and meets the minimum octane rating requirement.

Before using an oxygenated fuel, try to confirm the fuel's contents. Some states/provinces require this information to be posted on the pump.

The following are the U.S. EPA and Canadian CGSB approved percentages of oxygenates:

ETHANOL (ethyl or grain alcohol)
You may use gasoline containing up to 10 percent ethanol by volume. Gasoline containing ethanol may be marketed under the name "Gasohol."

MTBE (Methyl Tertiary Butyl Ether)
You may use gasoline containing up to 15 percent MTBE by volume.

METHANOL (methyl or wood alcohol)
Your vehicle was not designed to use fuel that contains methanol. Methanol can corrode metal parts in the fuel system, and also damage plastic and rubber components. This damage would not be covered by your warranties.

If you notice any undesirable operating symptoms, try another service station or switch to another brand of gasoline.

Fuel system damage or performance problems resulting from the use of an oxygenated fuel containing more than the percentages of oxygenates given above are not covered under warranty.

If you are planning to take your Honda outside the U.S. or Canada, contact the tourist bureaus in the areas you will be traveling in to find out about the availability of unleaded gasoline with the proper octane rating.

If unleaded gasoline is not available, be aware that using leaded gasoline in your Honda will affect performance and fuel mileage, and damage its emissions controls. It will no longer comply with U.S. and Canadian emissions regulations, and will be illegal to operate in North America. To bring your car back into compliance will require the replacement of several components, such as the oxygen sensors and the three way catalytic converter. These replacements are not covered under warranty.

The burning of gasoline in your car's engine produces several byproducts. Some of these are carbon monoxide (CO), oxides of nitrogen (NO_x) and hydrocarbons (HC). Gasoline evaporating from the tank also produces hydrocarbons. Controlling the production of NO_x, CO, and HC is important to the environment. Under certain conditions of sunlight and climate, NO_x and HC react to form photochemical "smog." Carbon monoxide does not contribute to smog creation, but it is a poisonous gas.

The Clean Air Act

The United States Clean Air Act* sets standards for automobile emissions. It also requires that automobile manufacturers explain to owners how their emissions controls work and what to do to maintain them. This section summarizes how the emissions controls work. Scheduled maintenance is on page [148](#).

* In Canada. Honda vehicles comply with the Canadian Motor Vehicle Safety Standards (CMVSS) for Emissions valid at the time they are manufactured.

Crankcase Emissions Control System

Your car has a Positive Crankcase Ventilation System. This keeps gasses that build up in the engine's crankcase from going into the atmosphere. The Positive Crankcase Ventilation valve routes them from

the crankcase back to the intake manifold. They are then drawn into the engine and burned.

Evaporative Emissions Control System

As gasoline evaporates in the fuel tank, an evaporative emissions control canister filled with charcoal adsorbs the vapor. It is stored in this canister while the engine is off. After the engine is started and warmed up, the vapor is drawn into the engine and burned during driving.

Exhaust Emissions Controls

The exhaust emissions controls include four systems: PGM-FI, Ignition Timing Control, Secondary Air Injection System and Three Way Catalytic Converter. These four systems work together to control the engine's combustion and minimize the amount of HC, CO, and NOx that comes out the tailpipe. The exhaust emissions control systems are separate from the crankcase and evaporative emissions control systems.

PGM-FI System

The PGM-FI System uses sequential multiport fuel injection. It has three subsystems: Air Intake, Engine Control, and Fuel Control. The Engine Control Module (ECM) uses various sensors to determine how much air is going into the engine. It then controls how much fuel to inject under all operating conditions.

Ignition Timing Control System

This system constantly adjusts the ignition timing, reducing the amount of HC, CO and NOx produced.

Secondary Air Injection System

During engine warm-up, air is pumped into the exhaust to reduce emissions when the engine is cold.

Three Way Catalytic Converter

The three way catalytic converter is in the exhaust system. Through chemical reactions, it converts HC, CO, and NOx in the engine's exhaust to carbon dioxide (CO₂), dinitrogen (N₂), and water vapor.

Replacement Parts

The emissions control systems are designed and certified to work together in reducing emissions to levels that comply with the Clean Air Act. To make sure the emissions remain low, you should use only new Genuine Honda replacement parts or their equivalent for repairs. Using lower quality parts may increase the emissions from your car.

The emissions control systems are covered by warranties separate from the rest of your car. Read your warranty manual for more information.

Three Way Catalytic Converter

The three way catalytic converter contains precious metals that serve as catalysts, promoting chemical reactions to convert the exhaust gasses without affecting the metals. The catalytic converter is referred to as a three-way catalyst, since it acts on HC, CO, and NOx. A replacement unit must be an original Honda part or its equivalent.

The three way catalytic converter must operate at a high temperature for the chemical reactions to take place. It can set on fire any combustible materials that come near it. Park your car away from high grass, dry leaves, or other flammables.

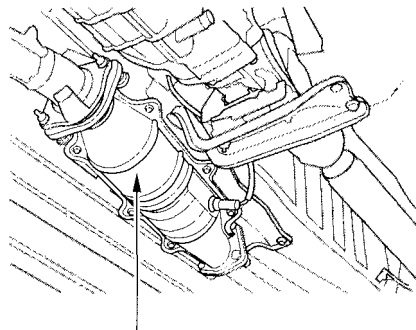

THREE WAY CATALYTIC CONVERTER

A defective three way catalytic converter contributes to air pollution, and can impair your engine's performance. Follow these guidelines to protect your car's three way catalytic converter.

- Always use unleaded gasoline. Even a small amount of leaded gasoline can contaminate the catalyst metals, making the three way catalytic converter ineffective.

- Keep the engine tuned-up.
- Have your car diagnosed and repaired if it is misfiring, back-firing, stalling, or otherwise not running properly.

Testing of Readiness Codes

If you take your vehicle for a state emissions test shortly after the battery has been disconnected or gone dead, it may not complete the test. This is because of certain "readiness codes" that must be set in the on-board diagnostics for the emissions systems. These codes are erased when the battery is disconnected, and set again only after several days of driving under a variety of conditions.

If the testing facility determines that the readiness codes are not set, you will be requested to return at a later date to complete the test. If you must get the vehicle re-tested within the next two or three days, you can condition the vehicle for re-testing by doing the following.

- Make sure the gas tank is nearly, but not completely, full (around 3/4).
- Make sure the vehicle has been parked with the engine off for 8 hours or more.
- Make sure the ambient temperature is between 20° and 95° F.

- Without touching the accelerator pedal, start the engine and let it idle for 20 seconds.
- Keep the vehicle on Neutral. Increase the engine speed to 2,000 rpm and hold it there until the temperature gauge rises to at least 1/4 of the scale (approximately 3 minutes).

CONTINUED

- Select a nearby lightly traveled major highway where you can maintain a speed of 50 to 60 mph for at least 20 minutes. Drive on the highway in 5th. Do not use the cruise control. When traffic allows, drive for 90 seconds without moving the accelerator pedal. (Vehicle speed may vary slightly; this is okay.) If you cannot do this for a continuous 90 seconds because of traffic conditions, drive for at least 30 seconds, then repeat it two more times (for a total of 90 seconds).

- Then drive in city/suburban traffic for at least 10 minutes. When traffic conditions allow, let the vehicle coast for several seconds without using the accelerator pedal or the brake pedal.

If the testing facility determines the readiness codes are still not set, see your Honda dealer.

Customer Relations	
Information.....	258
U.S. Zone Office Map.....	259
Canada Zone Office Map.....	260
Warranty Coverages.....	261
Reporting Safety Defects	
(U.S. Vehicles).....	262
Authorized Manuals.....	263

Customer Relations Information

Honda dealership personnel are trained professionals. They should be able to answer all your questions. If you encounter a problem that your dealership does not solve to your satisfaction, please discuss it with the dealership's management. The Service Manager or General Manager can help. Almost all problems are solved in this way.

If you are dissatisfied with the decision made by the dealership's management, contact your Honda Customer Relations Zone Office. Refer to the U.S. and Canadian Zone Office maps on the following pages.

When you call or write, please give us this information:

- Vehicle Identification Number (see page [244](#))
- Name and address of the dealer who services your car
- Date of purchase
- Mileage on your car
- Your name, address, and telephone number
- A detailed description of the problem
- Name of the dealer who sold the car to you

U.S. Zone Office Map

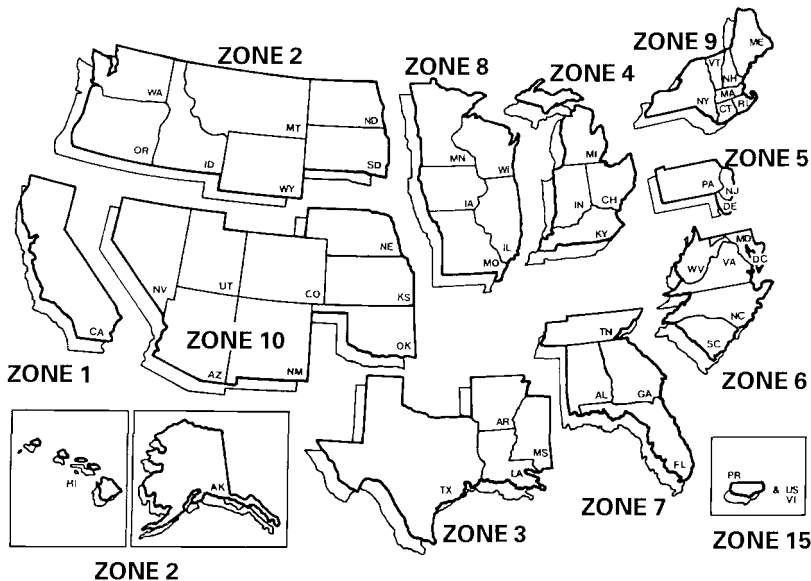

1 Western Zone
P.O. Box 2260
700 Van Ness Avenue
Torrance, California
90501-1490
(310)781-4565

2 Northwestern Zone
P.O. Box 20186
12439 N.E. Airport Way
Portland, Oregon 97230
(503) 256-0943
(also includes Alaska and Hawaii)

3 South Central Zone
4529 Royal Lane
Irving, Texas 75063
(972) 929-5481

4 Central Zone
101 South Stanfield Road
Troy, Ohio 45373
(937) 332-6250

5 Northeastern Zone
115 Gaither Drive
Mt. Laurel, New Jersey 08054
(856) 235-5533
Includes: NYC Metro area and Fairfield County, CT area

6 Mid-Atlantic Zone
902 Wind River Ln., Suite 200
Gaithersburg, Maryland 20878
(301)990-2020

7 Southeastern Zone
P.O. Box 1606
1500 Morrison Parkway
Alpharetta, Georgia 30009-1606
(770) 442-2045

8 North Central Zone
601 Campus Drive, Suite A-9
Arlington Heights, Illinois 60004
(847) 870-5600

9 New England Zone
555 Old County Road
Windsor Locks, Connecticut 06096
(860)623-3310
See Zone 5 for: NYC Metro area and Fairfield County, CT area

10 West Central Zone
1600 South Abilene Street, Suite D
Aurora, Colorado 80012
(303) 696-3935

15 Puerto Rico and U.S. V.I.
Bella International
P.O. Box 190816
San Juan, PR 00919-0816
(787) 250-4318

The addresses and telephone numbers are subject to change. If you cannot reach your Zone office, ask your Honda dealer for the current information.

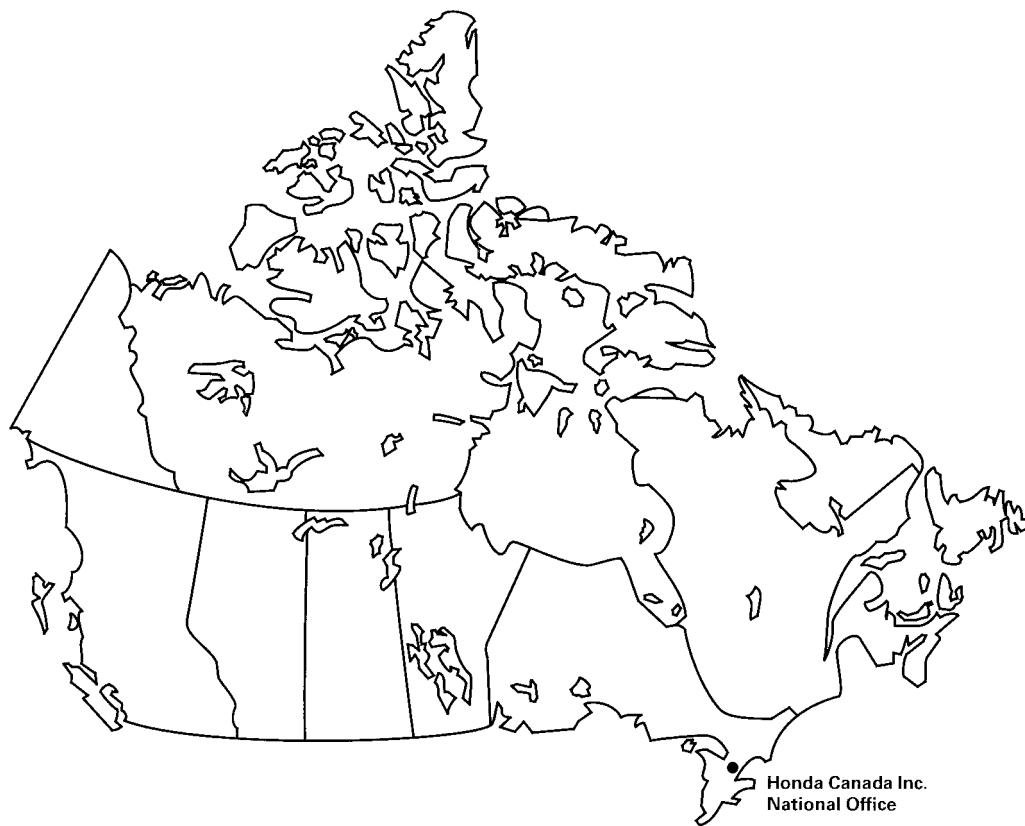

CUSTOMER RELATIONS RELATIONS AVEC LA CLIENTELE

Honda Canada Inc.
715 Milner Avenue
Toronto, ON
M1B 2K8

Tel: 1-888-9-HONDA-9

Fax: Toll-free 1-877-939-0909
Toronto (416)287-4776

U.S. Owners

Your new Honda is covered by these warranties:

New Car Limited Warranty — covers your new vehicle, except for the battery, emissions control systems and accessories, against defects in materials and workmanship.

Emissions Control Systems Defects Warranty and Emissions

Performance Warranty — these two warranties cover your car's emissions control systems. Time, mileage, and coverage are conditional. Please read the warranty manual for exact information.

Original Equipment Battery Limited Warranty — this warranty gives up to 100 percent credit toward a replacement battery.

Seat Belt Limited Warranty — a seat belt that fails to function properly is covered for the useful life of the vehicle.

Rust Perforation Limited Warranty — all exterior body panels are covered for rust-through from the inside for the specified time period with no mileage limit.

Accessory Limited Warranty — Genuine Honda Accessories are covered under this warranty. Time and mileage limits depend on the type of accessory and other factors. Please read your warranty manual for details.

Replacement Parts Limited Warranty — covers all genuine Honda replacement parts against defects in materials and workmanship.

Replacement Battery Limited Warranty — provides prorated coverage for a replacement battery purchased from a Honda dealer.

Replacement Muffler Lifetime Limited Warranty — provides coverage for as long as the purchaser of the muffler owns the car.

Restrictions and exclusions apply to all these warranties. Please read the 2001 Honda Warranty Information booklet that came with your car for precise information on warranty coverages. Your Honda's original tires are covered by their manufacturer. Tire warranty information is in a separate booklet.

Canadian Owners

Please refer to the 2001 Warranty Manual that came with your car.

Reporting Safety Defects (U.S. Vehicles)

If you believe that your vehicle has a defect which could cause a crash or could cause injury or death, you should immediately inform the National Highway Traffic Safety Administration (NHTSA) in addition to notifying American Honda Motor Co., Inc.

If NHTSA receives similar complaints, it may open an investigation, and if it finds that a safety defect exists in a group of vehicles, it may order a recall and remedy campaign. However, NHTSA cannot become involved in individual problems between you, your dealer, or American Honda Motor Co., Inc.

To contact NHTSA, you may either call the Auto Safety Hotline toll-free at 1-800-424-9393 (or 366-0123 in Washington D.C. area) or write to: NHTSA, U.S. Department of Transportation, Washington, D.C. 20590. You can also obtain other information about motor vehicle safety from the Hotline.

Purchasing Factory Authorized Manuals (U.S. only)

The following publications covering the operation and servicing of your car can be obtained from Helm Incorporated, either by filling out the attached form or, for credit card holders, calling the toll-free phone number on the form. For manuals prior to the year shown below, contact Helm Incorporated, P.O. Box 07280, Detroit, Michigan 48207, or call 1-800-782-4356.

Publication Form Number	From Description	Price Each*
61S2A01	2000-2001 Honda S2000 Service Manual	\$66.00
61S2A01EL	2000-2001 Honda S2000 Electrical Troubleshooting Manual	\$46.00
61S2A30	2000-2001 Honda S2000 Body Repair Manual	\$40.00
31S2A610	2001 Honda S2000 Owner's Manual	\$32.00
HON-R	Order Form for Previous Years- Indicate Year and Model Desired	FREE

* Prices are subject to change without notice and without incurring obligation.

Valid only for sales within the U.S. Canadian owners should contact their authorized Honda dealer.

ORDER TOLL FREE: 1-800-782-4356

(NOTE: For Credit Card Holder Orders Only)

Monday-Friday 8:00 A.M. – 6:00 P.M. EST

MINIMUM CREDIT CARD PURCHASE \$10.00

OR

By completing this form you can order the materials desired. You can pay by check or money order, or charge to your credit card. Mail to Helm Incorporated at the address shown on the back of the order form.

2001 HONDA	PUBLICATION NUMBER	VEHICLE MODEL		Qty	Price Each*	Total Price
		Name	Year			
* Prices are subject to change without notice and without incurring obligation.					TOTAL MATERIAL	
					Mich. Purchases Add 6% Sales Tax	
Orders are mailed within 10 days. Please allow adequate time for delivery.					HANDLING CHARGE	\$6.00
					GRAND TOTAL	

S H I P T O	NOTE: Dealers and Companies please provide dealer or company name, and also the name of the person to whose attention the shipment should be sent. For purchases outside U.S.A. please write to the address shown below for a quotation.	
	Customer Name _____	Attention _____
	Street Address - No P.O. Box Number _____	Apartment Number _____
	City _____	State & Zip Code _____
	Daytime Telephone Number () _____	

P A Y M E N T	<input type="checkbox"/> Check or money order enclosed payable to Helm Inc. U.S. funds only. Do not send cash		
	<input type="checkbox"/> Master Card	<input type="checkbox"/> VISA	<input type="checkbox"/> Check here if your billing address is different from the shipping address shown above.
	Account Number _____	Expiration: Mo. Yr. _____	
	<div style="display: flex; justify-content: space-between;"> <div style="border: 1px solid black; width: 20px; height: 20px;"></div> <div style="border: 1px solid black; width: 20px; height: 20px;"></div> <div style="border: 1px solid black; width: 20px; height: 20px;"></div> <div style="border: 1px solid black; width: 20px; height: 20px;"></div> <div style="border: 1px solid black; width: 20px; height: 20px;"></div> <div style="border: 1px solid black; width: 20px; height: 20px;"></div> <div style="border: 1px solid black; width: 20px; height: 20px;"></div> <div style="border: 1px solid black; width: 20px; height: 20px;"></div> <div style="border: 1px solid black; width: 20px; height: 20px;"></div> <div style="border: 1px solid black; width: 20px; height: 20px;"></div> </div>		
_____		_____	
CUSTOMER SIGNATURE		DATE	

These Publications cannot be returned for credit without receiving advance authorization within 14 days of delivery. On returns, a restocking fee may be applied against the original order.

HELM P.O. BOX 07280 DETROIT, MICHIGAN 48207 1-800-782-4356

Service Manual:

This manual covers maintenance and recommended procedures for repair to engine and chassis components. It is written for the Journeyman mechanic, but is simple enough for most mechanically-inclined owners to understand.

Electrical Troubleshooting Manual:

This manual complements the Service Manual by providing in-depth troubleshooting information for each electrical circuit in your car.

Body Repair Manual:

This manual describes the procedures involved in the replacement of damaged body parts.

A

Accessories	
Installation.....	122
Accessory Power Socket.....	82
ACCESSORY (Ignition Key	
Position).....	61
Additives, Engine Oil.....	158
Airbag (SRS).....	9
Air Cleaner Element.....	172
Air Conditioning.....	86
Maintenance.....	182
Usage.....	86
Air Outlets (Vents).....	88
Air Pressure, Tires.....	185
Alarm, Anti-theft.....	114
Alcohol in Gasoline.....	250
Aluminum Wheels, Cleaning.....	206
Antifreeze.....	161
Anti-lock Brakes (ABS)	
Indicator Light.....	45, 139
Operation.....	137
Anti-theft Steering Column Lock ..	60
Anti-theft System.....	114
Appearance Care.....	203
Audio Panel.....	82

Audio System.....	94
Automatic Car Washes.....	204
Automatic Speed Control.....	55

B

Back-up Lamp Replacement.....	198
Battery	
Charging System	
Indicator.....	44, 229
Jump Starting.....	222
Maintenance.....	177
Specifications.....	247
Before Driving.....	115
Belts, Seat.....	8
Beverage Holder.....	82
Body Repair.....	211
Brakes.....	136
Anti-lock System (ABS).....	137
Break-in, New Linings	116
Bulb Replacement.....	198
Fluid.....	170
Parking.....	81
System Indicator.....	44
Wear Indicators, Disc	136
Braking System.....	136

Break-in, New Car.....	116
Brightness Control, Instruments... ..	52
Brights, Headlights.....	51
Bulb Replacement.....	194
Back-up Lights.....	198
Brake Lights.....	198
Headlights.....	194
License Plate Lights.....	200
Side Marker Lights	196
Specifications.....	247
Turn Signal Lights.....	196
Bulbs, Halogen.....	194

C

Capacities Chart.....	246
Carbon Monoxide Hazard.....	39
Cargo, Carrying.....	124
CAUTION, Explanation of.....	ii
CD Changer.....	108
Certification Label.....	244
Chains.....	191

CONTINUED

Changing Oil	
How to.....	159
When to.....	146
Changing a Flat Tire	215
Changing Engine Coolant.....	163
Charging System Indicator ...	44, 229
Check Engine Light.....	45, 230
Checklist, Before Driving.....	130
Child Safety.....	19
Child Seats.....	22
Cleaner, Air.....	172
Cleaning.....	203
Aluminum Wheels.....	206
Carpeting.....	207
Exterior.....	204
Floor Mats.....	207
Interior.....	207
Leather.....	208
Seat Belts.....	208
Vinyl.....	208
Windows.....	209
Clutch Fluid.....	171
CO in the Exhaust.....	252
Cold Weather, Starting in.....	132
Compact Spare Tire.....	214
Controls, Instruments and.....	41

Convertible Top.....	72
Convertible Top Cover.....	77
Lowering the Convertible Top... ..	72
Maintenance.....	78
Raising the Convertible Top.....	75
Coolant	
Adding.....	161
Checking.....	120
Proper Solution.....	161
Temperature Gauge.....	47
Corrosion Protection.....	209
Crankcase Emission Control System.....	252
Cruise Control Operation.....	55
Customer Relations Information.....	258
D	
DANGER, Explanation of.....	ii
Dashboard.....	42
Daytime Running Lights.....	52
Defects, Reporting Safety.....	262
Defrosting the Windows.....	91
Dimensions.....	246
Dimming the Headlights	51

Dipstick	
Engine Oil.....	119
Directional Signals.....	53
Disc Brake Wear Indicators.....	136
Disposal of Used Oil.....	160
Do Not Tow a Trailer.....	141
Doors	
Locking and Unlocking.....	62
Monitor Light.....	45
Power Door Locks.....	62
DOT Tire Quality Grading.....	248
Downshifting, 6-speed Manual Transmission.....	134
Driving.....	129
Economy.....	121
In Bad Weather.....	140
In Foreign Countries.....	251

E

Economy, Fuel.....	121
Emergencies on the Road.....	213
Battery, Jump Starting.....	222
Changing a Flat Tire.....	215
Charging System Indicator	229
Checking the Fuses.....	235

Closing the Convertible Top....	233
Low Oil Pressure Indicator.....	228
Malfunction Indicator Lamp	230
Overheated Engine.....	225
Emergency Brake.....	81
Emergency Flashers.....	80
Emergency Trunk Opener.....	67
Emissions Controls.....	252
Emissions Testing, State	255
Engine	
Check Engine Light.....	45, 230
Compartment, Checking	
in the.....	118
Coolant.....	120
Coolant Temperature Gauge	47
Drive Belt.....	184
Malfunction Indicator	
Lamp.....	45, 230
Oil Pressure Indicator.....	44, 228
Oil, What Kind to Use.....	157
Overheating.....	225
Specifications.....	246
Speed Limiter.....	134
Starting.....	131
Engine Cover, Opening the.....	118
Ethanol in Gasoline	250

Evaporative Emission Controls....	252
Exhaust Fumes.....	39
Expectant Mothers, Use of Seat	
Belts by.....	17
Exterior, Cleaning the.....	204

F

Fabric, Cleaning.....	208
Fan, Interior.....	86
Features, Comfort and	
Convenience.....	85
Filling the Fuel Tank.....	117
Filters	
Oil.....	159
Flashers, Hazard Warning.....	80
Flat Tire, Changing a.....	215
Fluids	
Brake.....	170
Clutch.....	171
Manual Transmission.....	168
Windshield Washer.....	167
FM Stereo Radio Reception.....	103
Foreign Countries, Driving in.....	251
Four-way Flashers.....	80

Fuel.....	116
Fill Door and Cap.....	117
Gauge.....	48
Octane Requirement.....	116
Oxygenated.....	250
Reserve Indicator.....	46
Tank, Filling the.....	117
Fuel Mileage, Improving.....	121
Fuel Station Procedures	117
Fuses, Checking the.....	235

G

Gasohol.....	250
Gasoline.....	116
Fuel Reserve Indicator.....	46
Gauge.....	48
Octane Requirement.....	116
Oxygenated Fuels.....	250
Tank, Filling the.....	117

CONTINUED

Gauges.....	47
Engine Coolant Temperature ...	47
Fuel.....	48
Speedometer.....	47
Tachometer.....	47

Gearshift Lever Positions	
6-speed Manual	
Transmission.....	133
Glass Cleaning.....	209

H

Halogen Headlight Bulbs.....	194
Hazard Warning Flashers.....	80
Headlights	
Daytime Running Lights.....	52
High Beam Indicator.....	46
Reminder Tone.....	51
Replacing Halogen Bulbs	194
Turning on.....	51
Heating and Cooling System.....	86
High Altitude, Starting at.....	132
High-Low Beam Switch	51
High Speed, Shifting at.....	134
Hood Latch.....	174
Hood, Opening the	118

Hydraulic Clutch.....	171
Hydroplaning.....	141

I

Identification Number, Vehicle.....	244
Ignition	
Keys.....	58
Switch.....	60
Timing Control System.....	253
Indicator Lights, Instrument Panel.....	43
Inflation, Proper Tire	185
Inside Mirror.....	80
Inspection, Tire.....	187
Instrument Panel.....	42
Instrument Panel Brightness.....	52
Interior Cleaning.....	207
Interior Lights.....	83
Introduction.....	i

J

Jacking Up the Car.....	216
Jack, Tire.....	215

Jump Starting.....	222
--------------------	-----

K

Keys.....	58
-----------	----

L

Label, Certification.....	244
Lane Change, Signaling.....	53
Lap/Shoulder Belts.....	33
Leather, Cleaning.....	208
Lights	
Bulb Replacement.....	194
Indicator.....	43
Turn Signal.....	196
Loading Cargo.....	124
LOCK (Ignition Key Position).....	60
Locks	
Anti-theft Steering Column.....	60
Fuel Fill Door.....	117
Power Door.....	62
Trunk.....	66
Low Coolant Level.....	120
Lower Gear, Downshifting to a....	134
Low Fuel Indicator	46

Low Oil Pressure Indicator... 44, 228
 Lubricant Specifications Chart.... 246
 Luggage..... 124

M

Maintenance..... 143
 Owner Maintenance Checks.... 155
 Record..... 153
 Schedule..... 146
 Maintenance Required Indicator... 49
 Malfunction Indicator Lamp. 45, 230
 Manual Transmission..... 133
 Manual Transmission Fluid 168
 Meters, Gauges..... 47
 Methanol in Gasoline..... 250
 Mirrors, Adjusting..... 80

N

New Vehicle Break-in 116
 Normal Shift Speeds..... 134
 NOTICE, Explanation of..... ii
 Numbers, Identification..... 244

O

Octane Requirement, Gasoline... 116
 Odometer..... 48
 Odometer, Trip..... 48
 Oil
 Change, How to 159
 Change, When to..... 146
 Checking Engine..... 119
 Pressure Indicator..... 44, 228
 Selecting Proper Viscosity
 Chart..... 158
 ON (Ignition Key Position)..... 61
 Opening the Trunk..... 66
 Operation in Foreign Countries.. 251
 Outside Mirrors..... 80
 Overheating, Engine..... 225
 Oxygenated Fuels..... 250

P

Paint Touch-up..... 206
 Panel Brightness Control..... 52
 Parking Brake..... 81
 Parking Lights..... 51
 PGM-FI System..... 253

Polishing and Waxing..... 205
 Power
 Door Locks..... 62
 Engine, Specifications..... 246
 Mirrors..... 80
 Windows..... 70
 Pregnancy, Using Seat Belts..... 17
 Protecting Adults..... 12
 Additional Safety Precautions... 18
 Advice for Pregnant Women..... 17
 Protecting Children..... 19
 Protecting Larger Children..... 29
 Protecting Small Children..... 26

R

Radiator Overheating..... 225
 Radio Sound System..... 94
 Readiness Codes..... 255
 Rear Lights, Bulb Replacement.. 198
 Rear View Mirror..... 80
 Reclining the Seat-backs..... 69
 Recommended Shift Speeds 134

CONTINUED

Recovery Vehicle, Emergency			
Towing.....	241		
Reminder Lights.....	43		
Remote Transmitter.....	63		
Replacement Information			
Air Cleaner.....	172		
Engine Coolant.....	163		
Engine Oil and Filter.....	159		
Fuses.....	235		
Eight Bulbs.....	194		
Schedule.....	146		
Spark Plugs.....	174		
Tires.....	189		
Wiper Blades.....	180		
Replacing Seat Belts After a			
Crash.....	34		
Restraint, Child.....	19		
Rotation, Tire.....	188		
<div style="border: 1px solid black; padding: 2px; width: fit-content; margin: 10px 0;">S</div>			
Safety Belts.....	8	Seat Belts.....	8
Safety Defects, Reporting.....	262	Additional information.....	33
Safety Labels, Location of.....	40	Advice for pregnant Women.....	17
Safety Messages.....	ii	Cleaning.....	208
		Lap/Shoulder Belt.....	33
		Maintenance.....	34
		Reminder Eight and Beeper.....	44
		System Components.....	33
		Use During Pregnancy.....	17
		Seats, Adjusting the.....	69
		Serial Number.....	244
		Service Intervals.....	146
		Service Manual.....	263
		Service Station Procedures	117
		Shifting	
		The 6-speed Manual	
		Transmission.....	133
		Side Marker Lights, Bulb	
		Replacement in.....	196
		Signaling Turns.....	53
		6-speed Manual Transmission	
		Checking Fluid Level.....	168
		Shifting the.....	133
		Snow Tires.....	191
		Solvent-type Cleaners.....	204
		Sound System.....	94
		Spare Tire	
		Inflating.....	214
		Specifications.....	247
		Spark Plugs, Replacing.....	174
		Specifications Charts.....	246
		Speed Control.....	55
		Speedometer.....	47
		SRS, Additional Information.....	35
		Additional Safety Precautions....	38
		How the Automatic Seat Belt	
		Tensioners Work.....	37
		How the SRS Indicator	
		Works.....	37
		How Your Airbags Work.....	35
		SRS Components.....	35
		SRS Service.....	38
		SRS Indicator Light.....	37, 45
		Starting the Engine.....	131
		In Cold Weather at High	
		Altitude.....	132
		With a Dead Battery	222
		State Emissions Testing.....	255
		Steam Coming from Engine.....	225
		Steering Wheel	
		Anti-theft Column Lock.....	60
		Stereo Sound System	94

Storing Your Car.....	202
Stuck Car.....	239
Supplemental Restraint System	
Servicing.....	38
SRS Indicator.....	37, 45
Tensioners, Seat Belts.....	37

T

Tachometer.....	47
Taillights, Changing Bulbs in.....	198
Taking Care of the Unexpected ..	213
Technical Descriptions	
DOT Tire Quality Grading.....	248
Emissions Control Systems.....	250
Oxygenated Fuels.....	252
Three Way Catalytic Converter.....	254
Temperature Gauge.....	47
Tensioners, Seat Belts	37
Three Way Catalytic Converter...	254
Tire Chains.....	191
Tire, How to Change a Flat.....	215
Tires.....	185
Air Pressure.....	185
Balancing.....	188

Checking Wear.....	187
Compact Spare Tire	214
DOT Tire Quality Grading.....	248
Inflation.....	185
Inspection.....	187
Replacing.....	189
Rotating.....	188
Snow.....	191
Specifications.....	247
Tools, Tire Changing.....	215
Towing	
A Trailer, Do Not.....	141
Emergency Wrecker	240
Trailer, Do Not Tow a.....	141
Transmission	
Checking Fluid Level, 6-speed	
Manual Transmission.....	168
Fluid Selection.....	168
Identification Number.....	244
Shifting the 6-speed Manual	
Transmission.....	133
Treadwear.....	248
Trip Meter.....	48
Trunk.....	66
Emergency Trunk Opener.....	67
Opening the	66

Open Monitor Light.....	45
Turn Signals.....	53

U

Underside, Cleaning.....	209
Unexpected, Taking Care	
of the.....	213
Uniform Tire Quality Grading.....	248
Unleaded Gasoline.....	116
Upholstery Cleaning.....	207
Used Oil, How to Dispose of.....	160

V

Vehicle Dimensions.....	246
Vehicle Identification Number.....	244
Vehicle Storage.....	202
Ventilation.....	88
VIN.....	244
Vinyl Cleaning.....	208
Viscosity, Oil.....	158

CONTINUED

W

WARNING, Explanation of.....	ii
Warning Labels, Location of.....	40
Warranty Coverages.....	261
Washer, Windshield	
Checking the Fluid Level.....	167
Operation.....	54
Washing.....	204
Waxing and Polishing.....	205
Wheels.....	189
Alignment and Balance.....	188
Cleaning Aluminum Alloys.....	206
Wrench.....	215
Windows	
Cleaning.....	209
Operating the Power.....	70
Windshield	
Cleaning.....	209
Defroster.....	91
Washers.....	54
Wipers, Windshield	
Changing Blades.....	180
Operation.....	53
Worn Tires.....	187
Wrecker, Emergency Towing.....	241

Service Information Summary

Gasoline:

Premium unleaded gasoline, pump octane number of 91 or higher.

Fuel Tank Capacity:

13.2 US gal (50 l ,11.0 Imp gal)

Recommended Engine Oil:

API Service SJ "Energy Conserving" oil, SAE 10W-30 viscosity (see page [158](#)).

Oil change capacity (including filter):

5.1 US qt(4.8 l ,4.2 Imp qt)

6-speed Manual Transmission

Fluid:

Honda Manual Transmission Fluid preferred, or an API service SG, SH or SJ, SAE 10W-30 or 10W-40 motor oil as a temporary replacement (see page [168](#)).

Capacity:

1.6 US qt(1.5 l ,1.3 Imp qt)

Brake Fluid:

Honda Heavy Duty Brake Fluid DOT 3 preferred, or a DOT 3 or DOT 4 brake fluid as a temporary replacement (see page [170](#)).

Tire Pressure (measured cold):

Front:

32 psi (220 kPa , 2.2 kgf/cm²)

Rear:

32 psi (220 kPa , 2.2 kgf/cm²)

Spare Tire Pressure:

Front:

60 psi (420 kPa , 4.2 kgf/cm²)