

# 2004 Civic Coupe Online Reference Owner's Manual

Use these links (and links throughout this manual) to navigate through this reference. For a printed owner's manual, click on authorized manuals or go to [www.helminc.com](http://www.helminc.com).

## Contents

---

### Owner's Identification Form

<b>Introduction</b> .....	<b>i</b>
<b>A Few Words About Safety</b> .....	<b>ii</b>
<b>Your Vehicle at a Glance</b> .....	<b>2</b>
<b>Driver and Passenger Safety</b> .....	<b>5</b>
Proper use and care of your vehicle's seat belts, and Supplemental Restraint System.	
<b>Instruments and Controls</b> .....	<b>51</b>
Instrument panel indicator and gauge, and how to use dashboard and steering column controls.	
<b>Comfort and Convenience Features</b> .....	<b>89</b>
How to operate the climate control system, the audio system, and other convenience features.	
<b>Before Driving</b> .....	<b>113</b>
What gasoline to use, how to break-in your new vehicle, and how to load luggage and other cargo.	
<b>Driving</b> .....	<b>125</b>
The proper way to start the engine, shift the transmission, and park, plus towing a trailer.	
<b>Maintenance</b> .....	<b>141</b>
The Maintenance Schedule shows you when you need to take your vehicle to the dealer.	
<b>Taking Care of the Unexpected</b> .....	<b>181</b>
This section covers several problems motorists sometimes experience, and how to handle them.	
<b>Technical Information</b> .....	<b>205</b>
ID numbers, dimensions, capacities, and technical information.	
<b>Warranty and Customer Relations (U.S. and Canada only)</b> .....	<b>217</b>
A summary of the warranties covering your new Acura, and how to contact us.	
<b>Authorized Manuals (U.S. only)</b> .....	<b>221</b>
How to order manuals and other technical literature.	
<b>Index</b> .....	<b>I</b>

### Service Information Summary

A summary of information you need when you pull up to the fuel pump.

# Owner's Identification

---

OWNER \_\_\_\_\_

ADDRESS \_\_\_\_\_

STREET

\_\_\_\_\_

CITY

STATE/PROVINCE

ZIP CODE/  
POSTAL CODE

V. I. N. \_\_\_\_\_

DELIVERY DATE \_\_\_\_\_

(Date sold to original retail purchaser)

DEALER NAME \_\_\_\_\_ DEALER NO. \_\_\_\_\_

ADDRESS \_\_\_\_\_

STREET

\_\_\_\_\_

CITY

STATE/PROVINCE

ZIP CODE/  
POSTAL CODE

OWNER'S SIGNATURE \_\_\_\_\_

DEALER'S SIGNATURE \_\_\_\_\_

This Owner's Manual should be considered a permanent part of the vehicle, and should remain with the vehicle when it is sold.

This Owner's Manual covers all models of the Civic Coupe. You may find descriptions of equipment and features that are not on your particular model.

The information and specifications included in this publication were in effect at the time of approval for printing. Honda Motor Co., Ltd. reserves the right, however, to discontinue or change specifications or design at any time without notice and without incurring any obligation whatsoever.

**POUR CLIENTS CANADIEN  
AVIS IMPORTANT: Si vous avez  
besoin d'un Manuel du Conducteur  
en français, veuillez demander à  
votre concessionnaire de  
commander le numéro de pièce  
33S5PC30**

Congratulations! Your selection of a 2004 Honda Civic was a wise investment. It will give you years of driving pleasure.

One of the best ways to enhance the enjoyment of your new Honda is to read this manual. In it, you will learn how to operate its driving controls and convenience items. Afterwards, keep this owner's manual in your vehicle so you can refer to it at any time.

Several warranties protect your new Honda. Read the warranty booklet thoroughly so you understand the coverages and are aware of your rights and responsibilities.

Maintaining your vehicle according to the schedules given in this manual helps to keep your driving trouble-free while it preserves your investment. When your vehicle needs maintenance, keep in mind that your Honda dealer's staff is specially trained in servicing the many systems unique to your Honda. Your Honda dealer is dedicated to your satisfaction and will be pleased to answer any questions and concerns.

## California Proposition 65 Warning

**WARNING:** This product contains or emits chemicals known to the State of California to cause cancer and birth defects or other reproductive harm.

As you read this manual, you will find information that is preceded by a **NOTICE** symbol. This information is intended to help you avoid damage to your Honda, other property, or the environment.

# A Few Words About Safety

---

Your safety, and the safety of others, is very important. And operating this vehicle safely is an important responsibility.

To help you make informed decisions about safety, we have provided operating procedures and other information on labels and in this manual. This information alerts you to potential hazards that could hurt you or others.

Of course, it is not practical or possible to warn you about all the hazards associated with operating or maintaining your vehicle. You must use your own good judgement.

You will find this important safety information in a variety of forms, including:

- **Safety Labels** – on the vehicle.
- **Safety Messages** – preceded by a safety alert symbol  and one of three signal words: **DANGER**, **WARNING**, or **CAUTION**.  
These signal words mean:

 **DANGER**

You **WILL** be **KILLED** or **SERIOUSLY HURT** if you don't follow instructions.

 **WARNING**

You **CAN** be **KILLED** or **SERIOUSLY HURT** if you don't follow instructions.

 **CAUTION**

You **CAN** be **HURT** if you don't follow instructions.

- **Safety Headings** – such as Important Safety Reminders or Important Safety Precautions.
- **Safety Section** – such as Driver and Passenger Safety.
- **Instructions** – how to use this vehicle correctly and safely.

This entire book is filled with important safety information – please read it carefully.

# Your Vehicle at a Glance

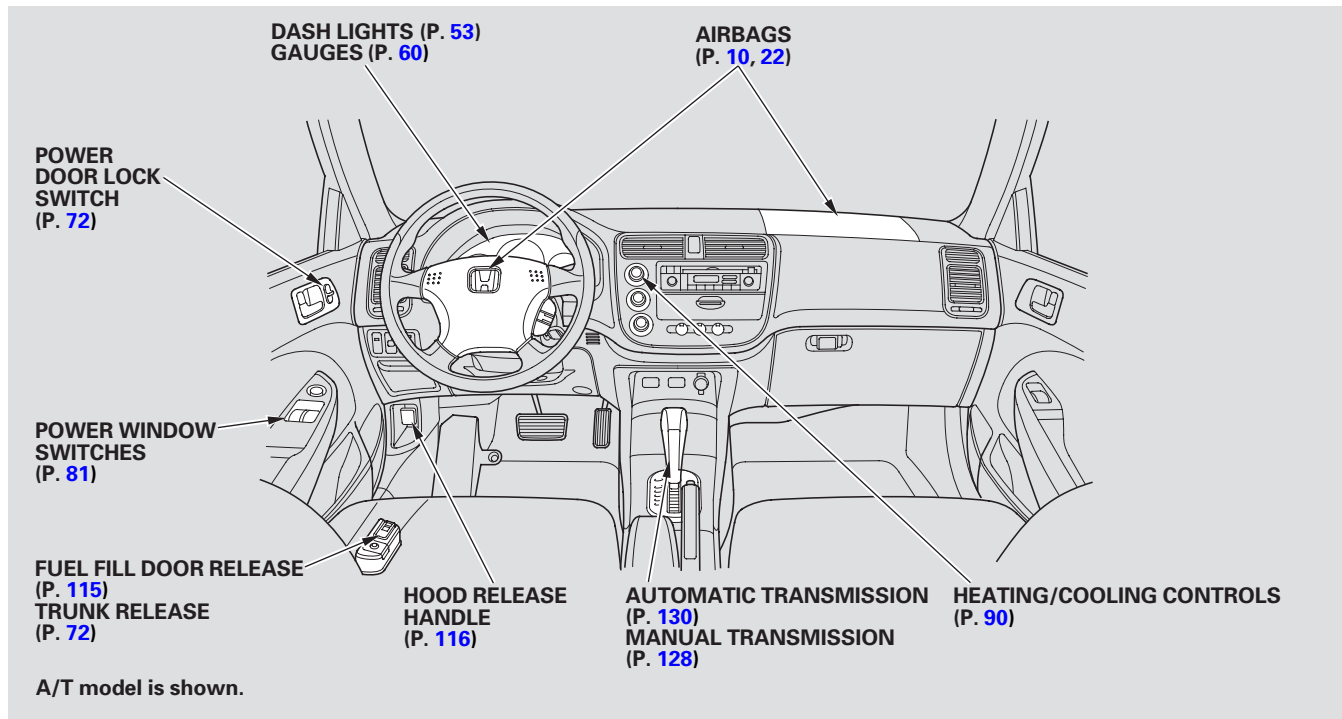

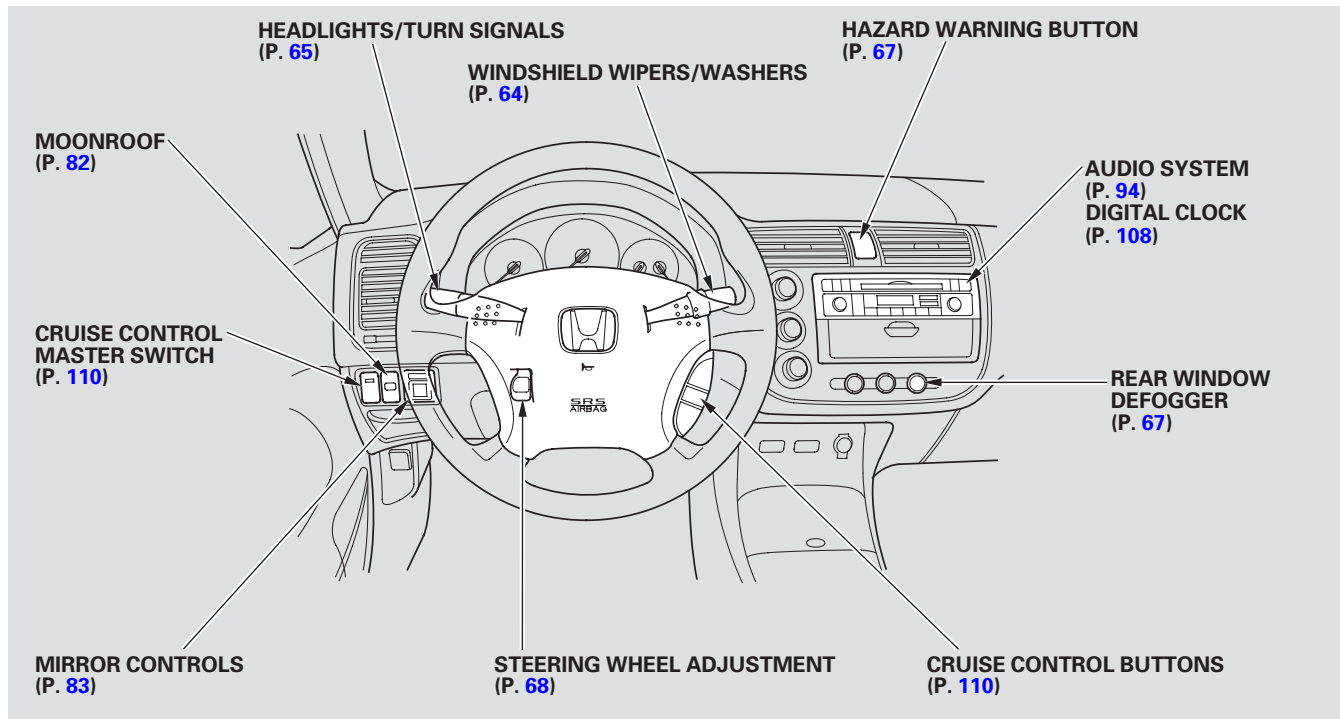



This section gives you important information about how to protect yourself and your passengers. It shows you how to use seat belts properly. It explains how your airbags work. And it tells you how to properly restrain infants and children in your vehicle.

Important Safety Precautions .....	6
Your Vehicle's Safety Features.....	7
Seat Belts .....	8
Airbags.....	10
Protecting Adults and Teens.....	11
1. Close and Lock the Doors .....	11
2. Adjust the Front Seats .....	11
3. Adjust the Seat-Backs .....	13
4. Adjust the Head Restraints ....	14
5. Fasten and Position the Lap/ Shoulder Seat Belts .....	14
6. Adjust the Steering Wheel .....	16

7. Maintain a Proper Sitting Position .....	16
Advice for Pregnant Women.....	17
Additional Safety Precautions....	18
Additional Information About Your Seat Belts .....	19
Seat Belt System Components...	19
Lap/Shoulder Belt .....	19
Automatic Seat Belt Tensioners.....	20
Seat Belt Maintenance .....	21
Additional Information About Your Airbags .....	22
Airbag System Components.....	22
How Your Front Airbags Work.....	22
How Your Side Airbags Work....	25
How the SRS Indicator Works... ..	26
How the side Airbag Off Indicator Works .....	27
Airbag Service .....	28
Additional Safety Precautions....	28
Protecting Children – General Guidelines.....	29
All Children Must Be Restrained .....	29

All Children Should Sit in the Back Seat .....	30
The Passenger's Front Airbag Can Pose Serious Risks .....	30
If You Must Drive with Several Children .....	32
If a Child Requires Close Attention .....	32
Additional Safety Precautions....	33
Protecting Infants.....	34
Protecting Small Children .....	35
Selecting a Child Seat.....	36
Installing a Child Seat .....	37
Installing a Child Seat Using LATCH.....	38
Installing a Child Seat with a Lap/shoulder Belt .....	40
Installing a Child Seat with a Tether .....	42
Protecting Larger Children .....	43
Checking Seat Belt Fit .....	44
Using a Booster Seat .....	44
Additional Safety Precautions....	46
Carbon Monoxide Hazard .....	47
Safety Labels .....	48



# Important Safety Precautions

---

You'll find many safety recommendations throughout this section, and throughout this manual. The recommendations on this page are the ones we consider to be the most important.

## **Always Wear Your Seat Belt**

A seat belt is your best protection in all types of collisions. Airbags supplement seat belts, but airbags are designed to inflate only in a moderate to severe frontal collision. So even though your vehicle is equipped with airbags, make sure you and your passengers always wear your seat belts, and wear them properly (see page 14).

## **Restrain All Children**

Children age 12 and under should ride properly restrained in a back seat. Infants and small children should be restrained in a child seat. Larger children should use a booster and a lap/shoulder belt until they

can use the belt properly without a booster (see page 29).

## **Be Aware of Airbag Hazards**

While airbags can save lives, they can cause serious or fatal injuries to occupants who sit too close to them, or are not properly restrained. Infants, young children, and short adults are at the greatest risk. Be sure to follow all instructions and warnings in this manual.

## **Don't Drink and Drive**

Alcohol and driving don't mix. Even one drink can reduce your ability to respond to changing conditions, and your reaction time gets worse with every additional drink. So don't drink and drive, and don't let your friends drink and drive, either.

## **Control Your Speed**

Excessive speed is a major factor in crash injuries and deaths. Generally, the higher the speed, the greater the risk, but serious injuries can also occur at lower speeds. Never drive faster than is safe for current conditions, regardless of the maximum speed posted.

## **Keep Your Vehicle in Safe Condition**

Having a tire blowout or a mechanical failure can be extremely hazardous. To reduce the possibility of such problems, check your tire pressures and condition frequently, and perform all regularly scheduled maintenance (see page 145).

# Your Vehicle's Safety Features

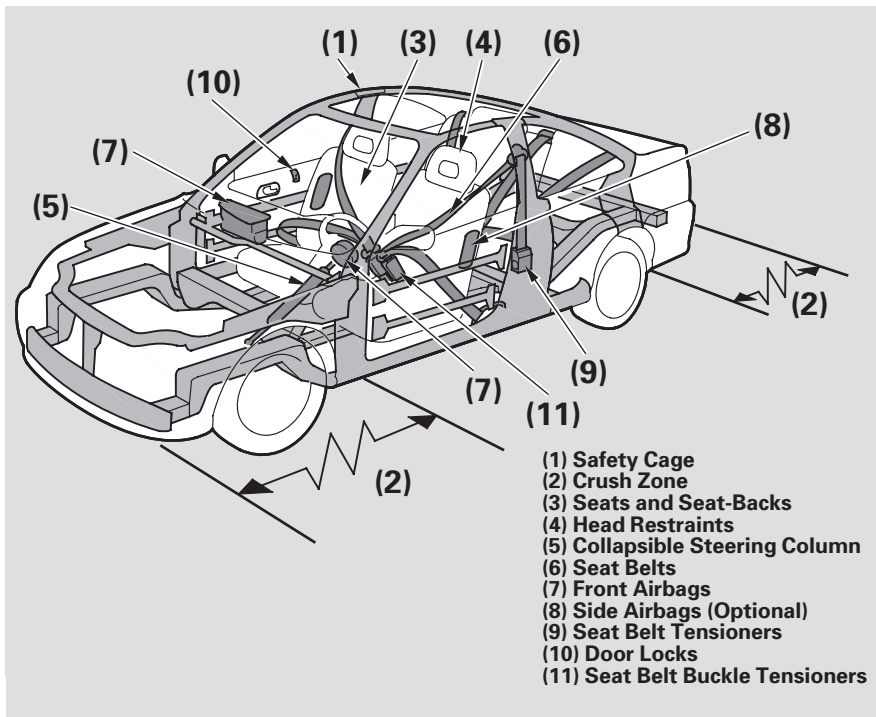

Your vehicle is equipped with many features that work together to protect you and your passengers during a crash.

Some safety features do not require any action on your part. These include a strong steel framework that forms a safety cage around the passenger compartment; front and rear crush zones, a collapsible steering column, and seat belt tensioners that tighten the front seat belts in the event of a crash.

*CONTINUED*

# Your Vehicle's Safety Features

---

However, you and your passengers can't take full advantage of these safety features unless you remain sitting in a proper position and always wear your seat belts properly. In fact, some safety features can contribute to injuries if they are not used properly.

The following pages explain how you can take an active role in protecting yourself and your passengers.

## Seat Belts

Your vehicle is equipped with seat belts in all seating positions.



Your seat belt system also includes an indicator on the instrument panel to remind you and your passengers to fasten your seat belts.

## *Why Wear Seat Belts*

Seat belts are the single most effective safety device for adults and larger children (Infants and smaller children must be properly restrained in child seats).

Not wearing a seat belt properly increases the chance of serious injury or death in a crash, even though your vehicle has airbags.

In addition, most states and all Canadian provinces require you to wear seat belts.

## **⚠️ WARNING**

Not wearing a seat belt properly increases the chance of serious injury or death in a crash, even if you have airbags.

Be sure you and your passengers always wear seat belts and wear them properly.

When properly worn, seat belts:

- Keep you connected to the vehicle so you can take advantage of the vehicle's built-in safety features.
- Help protect you in almost every type of crash, including frontal, side, and rear impacts and rollovers.

- Help keep you from being thrown against the inside of the vehicle and against other occupants.
- Keep you from being thrown out of the vehicle.
- Help keep you in a good position should the airbags ever deploy. A good position reduces the risk of injury from an inflating airbag, and allows you to get the best advantage from the airbag.

Of course, seat belts cannot completely protect you in every crash. But in most cases, seat belts can reduce your risk of serious injury.

### ***What You Should Do:***

Always wear your seat belt, and make sure you wear it properly.

# Your Vehicle's Safety Features

## Airbags

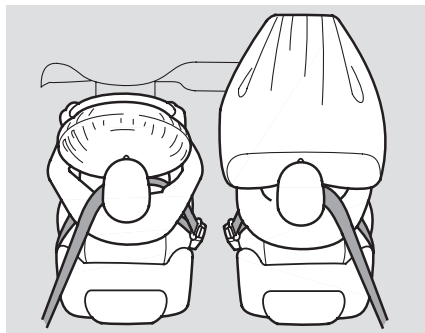

Your vehicle has a Supplemental Restraint System (SRS) with front airbags to help protect the heads and chests of the driver and a front seat passenger during a moderate to severe frontal collision (see page 22 for more information on how your front airbags work).

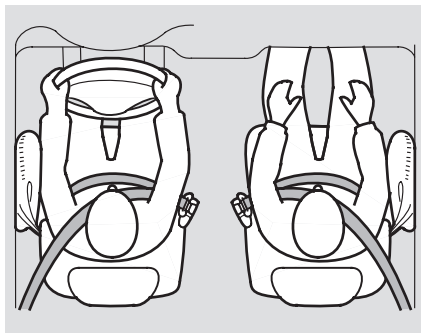

*Only on models equipped with side airbags*  
Your vehicle also has side airbags to help protect the upper torso of the driver or a front seat passenger during a moderate to severe side impact (see page 25 for more information on how your side airbags work).

The most important things you need to know about your airbags are:

- **Airbags do not replace seat belts.** They are designed to supplement the seat belts.
- **Airbags offer no protection in rear impacts, or minor frontal or side collisions.**
- **Airbags can pose hazards.** To do their job, airbags must inflate with tremendous force. So while airbags help save lives they can cause minor injuries, or more serious or even fatal injuries if occupants are not properly restrained or sitting properly.

**What you should do:** Always wear your seat belt properly, and sit upright, and as far back as possible from the steering wheel while allowing full control of the vehicle. A front passenger should move their seat as far back from the dashboard as possible.

The rest of this section gives more detailed information about how you can maximize your safety.

Remember however, that no safety system can prevent all injuries or deaths that can occur in severe crashes, even where seat belts are properly worn and the airbags deploy.

The following pages provide instructions on how to properly protect the driver, adult passengers and teenage children who are large enough and mature enough to ride in the front seat.

See [page 30](#) for important guidelines on how to properly protect infants, small children, and larger children who ride in your vehicle.

## 1. Close and Lock the Doors

After everyone has entered the vehicle, be sure the doors are closed and locked.

Locking the doors reduces the chance of someone being thrown out of the vehicle during a crash and it helps prevent passengers from accidentally opening and falling out.

Locking the doors also helps prevent an outsider from unexpectedly opening a door when you come to a stop.

See [page 72](#) for how to lock the doors.

## 2. Adjust the Front Seats

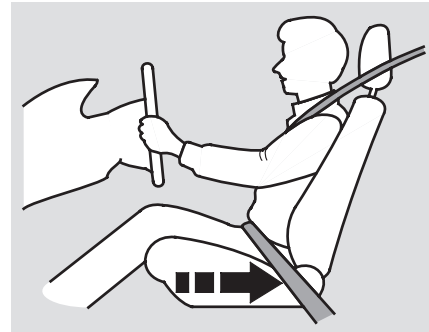

Adjust the driver's seat as far to the rear as possible while allowing you to maintain full control of the vehicle. Have a front passenger adjust their seat as far to the rear as possible.

If you sit too close to the steering wheel or dashboard, you can be seriously injured by an inflating front airbag, or by striking the steering wheel or dashboard.

*CONTINUED*

# Protecting Adults and Teens

---

The National Highway Traffic Safety Administration and Transport Canada recommend that drivers allow at least 10 inches (25 cm) between the center of the steering wheel and the chest.

If you cannot get far enough away from the steering wheel and still reach the controls, we recommend that you investigate whether some type of adaptive equipment may help.

## **WARNING**

Sitting too close to a front airbag can result in serious injury or death if the front airbags inflate.

Always sit as far back from the front airbags as possible.

Once your seat is adjusted correctly, rock it back and forth to make sure it is locked into position. See page [76](#) for how to adjust the front seats.

A front passenger should also adjust the seat-back to an upright position, but as far from the dashboard as possible. A passenger who sits too close to the dashboard could be injured if the front airbag inflates.

## 3. Adjust the Seat-Backs

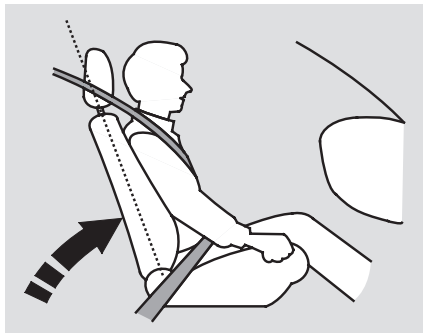

Adjust the driver's seat-back to a comfortable, upright position, leaving ample space between your chest and the airbag cover in the center of the steering wheel.

Passengers with adjustable seat-backs should also adjust their seat-back to a comfortable, upright position.

Reclining a seat-back so that the shoulder part of the belt no longer rests against the occupant's chest reduces the protective capability of the belt. It also increases the chance of sliding under the belt in a crash and being seriously injured. The farther a seat-back is reclined, the greater the risk of injury.

See page [76](#) for how to adjust seat-backs.

### **⚠ WARNING**

Reclining the seat-back too far can result in serious injury or death in a crash.

Adjust the seat-back to an upright position, and sit well back in the seat.



## 4. Adjust the Head Restraints

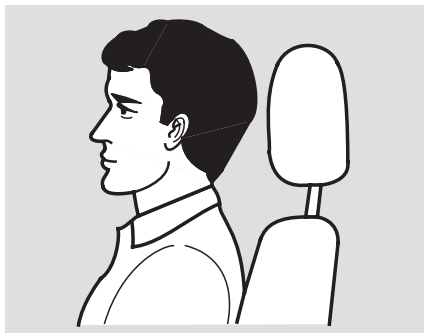

Adjust the driver's head restraint so the back of your head rests against the center of the restraint.

Have passengers with adjustable restraints adjust their restraints properly as well. Taller persons should adjust their restraint as high as possible.

## **⚠ WARNING**

Improperly positioning head restraints reduces their effectiveness and you can be seriously injured in a crash.

Make sure head restraints are in place and positioned properly before driving.

Properly adjusted head restraints will help protect occupants from whiplash and other crash injuries.

See page [78](#) for how to adjust the head restraints.

## 5. Fasten and Position the Lap/Shoulder Seat Belts

Insert the latch plate into the buckle, then tug on the belt to make sure the belt is securely latched. Also check that the belt is not twisted, because a twisted belt can cause serious injuries in a crash.

Position the lap part of the belt as low as possible across your hips, then pull up on the shoulder part of the belt so the lap part fits snugly. This lets your strong pelvic bones take the force of a crash and reduces the chance of internal injuries.



If necessary, pull up on the belt again to remove any slack, then check that the belt rests across the center of your chest and over your shoulder. This spreads the forces of a crash over the strongest bones in your upper body.

If the seat belt touches or crosses your neck, or if it crosses your arm instead of your shoulder, you need to adjust the seat belt anchor height.

*Never place the shoulder portion of a lap/shoulder belt under your arm or behind your back.* This could cause very serious injuries in a crash.

### **⚠ WARNING**

Improperly positioning the seat belts can cause serious injury or death in a crash.

Make sure all seat belts are properly positioned before driving.

If a seat belt does not seem to work as it should, it may not protect the occupant in a crash.

*No one should sit in a seat with an inoperative seat belt.* Using a seat belt that is not working properly can result in serious injury or death. Have your Honda dealer check the belt as soon as possible.

See page 19 for additional information about your seat belts and how to take care of them.

*CONTINUED*

# Protecting Adults and Teens

Pull up on the shoulder belt to remove any slack, then check that the belt rests across the center of your chest and over your shoulder. This spreads the forces of a crash over the strongest bones in your upper body.

*Never place the shoulder portion of a lap/shoulder belt under your arm or behind your back.* This could cause very serious injuries in a crash.

## 6. Adjust the Steering Wheel

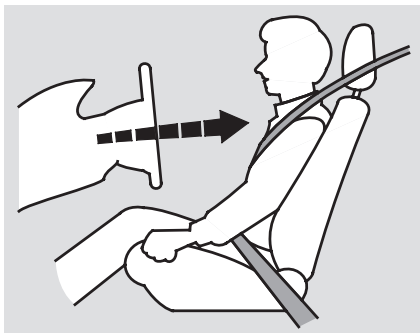

Adjust the steering wheel, if needed, so that the wheel points toward your chest, not toward your face. This provides optimal protection from the front airbag.

See page [68](#) for how to adjust the steering wheel.

## 7. Maintain a Proper Sitting Position

After all occupants have adjusted their seats and put on seat belts, it is very important that they continue to sit upright, well back in their seats, with their feet on the floor, until the vehicle is parked and the engine is off.

Sitting improperly can increase the chance of injury during a crash. For example, if an occupant slouches, lies down, turns sideways, sits forward, leans forward or sideways, or puts one or both feet up, the chance of injury during a crash is greatly increased.

In addition, an occupant who is out of position in the front seat can be seriously or fatally injured in a crash by striking interior parts of the vehicle or being struck by an inflating front airbag. Being struck by an inflating side airbag can possibly result in serious injuries.

### **▲ WARNING**

Sitting improperly or out of position can result in serious injury or death.

Always sit upright, well back in the seat, with your feet on the floor.

### **Advice for Pregnant Women**



If you are pregnant, the best way to protect yourself and your unborn child when driving or riding in a car is to always wear a seat belt, and keep the lap part of the belt as low as possible across the hips.

When driving, remember to sit upright and adjust the seat as far back as possible while allowing full control of the vehicle. When riding as a front passenger, adjust the seat as far back as possible.

This will reduce the risk of injuries to both you and your unborn child that can be caused by a crash or an inflating front airbag.

Each time you have a check-up, ask your doctor if it's okay for you to drive.

# Protecting Adults and Teens

---

## Additional Safety Precautions

- ***Two people should never use the same seat belt.*** If they do, they could be very seriously injured in a crash.
- ***Do not put any accessories on seat belts.*** Devices intended to improve occupant comfort or reposition the shoulder part of a seat belt can severely compromise the protective capability of the seat belt and increase the chance of serious injury in a crash.

- ***Do not place hard or sharp objects between yourself and a front airbag.*** Carrying hard or sharp objects on your lap, or driving with a pipe or other sharp objects in your mouth, can result in injuries if your front airbag inflates.
- ***Keep your hands and arms away from the airbag covers.*** If your hands or arms are close to an airbag cover, they could be injured if the front airbag inflates.
- ***Do not attach or place objects on the front airbag covers.*** Objects on the covers marked “SRS AIRBAG” could interfere with the proper operation of the airbags. Or, if the airbags inflate, the objects could be propelled inside the vehicle and hurt someone if the airbags inflate.

- ***On models with side airbags, do not attach hard objects on or near a door.*** If a side airbag inflates, a cup holder or other hard object attached on or near the door could be propelled inside the vehicle and hurt someone.

### Seat Belt System Components

Your seat belt system includes lap/shoulder belts in all five seating positions. The front seat belts are also equipped with automatic seat belt tensioners.



The seat belt system includes an indicator on the instrument panel and a beeper to remind you and your passengers to fasten your seat belts.

If you turn the ignition switch to ON (II) before fastening your belt, the beeper sounds and the indicator flashes. If you do not fasten your seat belt before the beeper stops, the indicator stops flashing but remains on.

If you continue driving without fastening your seat belt, the beeper sounds and the indicator flashes again at regular intervals.

### Lap/Shoulder Belt

The lap and shoulder belt goes over your shoulder, across your chest, and across your hips.

To fasten the belt, insert the latch plate into the buckle, then tug on the belt to make sure the buckle is latched (see page 14 for how to properly position the belt).

To unlock the belt, push the red PRESS button on the buckle. Guide the belt across your body so that it retracts completely. After exiting the vehicle, be sure the belt is out of the way and will not get closed in the door.

All seat belts have an emergency locking retractor. In normal driving, the retractor lets you move freely in your seat while it keeps some tension on the belt. During a collision or sudden stop, the retractor automatically locks the belt to help restrain your body.

The seat belts in all positions except the driver's have an additional locking mechanism that must be activated to secure a child seat (see page 40 ).

If the shoulder part of the belt is pulled all the way out, the locking mechanism will activate. The belt will retract, but it will not allow the passenger to move freely.

*CONTINUED*

## Additional Information About Your Seat Belts

---

To deactivate the locking mechanism, unlatch the buckle, and let the seat belt fully retract. To refasten the belt, pull it out only as far as needed.

### Automatic Seat Belt Tensioners

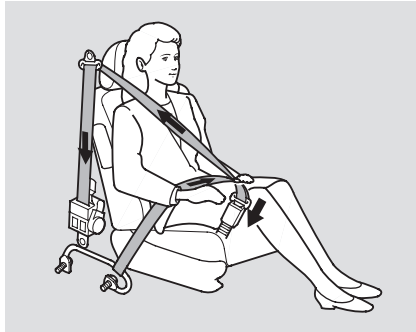

For added protection, the front seat belts are equipped with automatic seat belt tensioners. When activated, the tensioners immediately tighten the belts to help hold the driver and a front passenger in place.

The tensioners are designed to activate primarily in frontal collisions, and they should activate in any collision severe enough to cause front-airbag inflation.

However, the tensioners can be activated during a collision where the front airbags do not deploy. In this case, the airbags would not be needed, but the additional restraint could be helpful.

When the tensioners are activated, the seat belts will remain tight until they are unbuckled in the normal manner.

### Seat Belt Maintenance

For safety, you should check the condition of your seat belts regularly.

Pull each belt out fully and look for frays, cuts, burns, and wear. Check that the latches work smoothly and the belts retract easily. Any belt not in good condition or not working properly will not provide good protection and should be replaced as soon as possible.

Honda provides a lifetime warranty on seat belts for U.S. models. See your *Honda Warranty Information* booklet for details.

If a seat belt is worn during a crash, it must be replaced by the dealer. A belt that has been worn during a crash may not provide the same level of protection in a subsequent crash. The dealer should also inspect the anchors for damage and replace them if needed. If the automatic seat belt tensioners activate during a crash, they must be replaced.

For information on how to clean your seat belts, see page [169](#).

### WARNING

Not checking or maintaining seat belts can result in serious injury or death if the seat belts do not work properly when needed.

Check your seat belts regularly and have any problem corrected as soon as possible.



# Additional Information About Your Airbags

## Airbag System Components

Your airbag system includes:

- Two SRS (Supplemental Restraint System) front airbags. The driver's airbag is stored in the center of the steering wheel; the front passenger's airbag is stored in the dashboard. Both are marked "SRS AIRBAG."
- *On models equipped with side airbags*, one for the driver and one for a front passenger. The airbags are stored in the outer edges of the seat-backs. Both are marked "SIDE AIRBAG" (see page 25).
- Automatic front seat belt tensioners (see page 20).
- Sensors that can detect a moderate to severe frontal impact or side impact in models equipped with side airbags.

- A sophisticated electronic system that continually monitors and records information about the sensors, the control unit, the airbag activators, and driver and front passenger seat belt use when the ignition is in the ON (II) position.
- An indicator on the instrument panel that alerts you to a possible problem with your airbags (see page 26).
- *On models equipped with side airbags*, an indicator on the dashboard that alerts you that the passenger's side airbag has been turned off (see page 27).
- Emergency backup power in case your vehicle's electrical system is disconnected in a crash.

## How Your Front Airbags Work

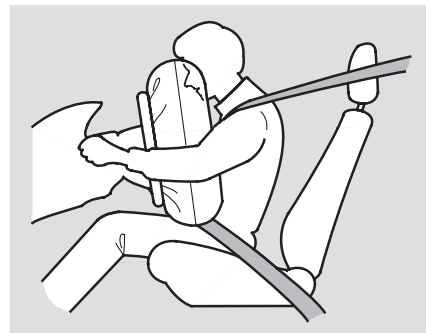

If you ever have a moderate to severe frontal collision, sensors will detect the vehicle's rapid deceleration. If the rate of deceleration is high enough, the control unit will instantly inflate the driver's and front passenger's front airbags, at the time and with the force needed.

During a frontal crash, your seat belt restrains your lower body and torso, and the airbag helps protect your head and chest.

Although both airbags normally inflate within split second of each other, it is possible for only one airbag to deploy.

This can happen if the severity of a collision is at the margin, or threshold, that determines whether or not the airbags will deploy. In such cases, the seat belt will provide sufficient protection, and the supplemental protection offered by the airbag would be minimal.

After inflating, the front airbags immediately deflate, so they won't interfere with the driver's visibility, or the ability to steer or operate other controls.

The total time for inflation and deflation is one-tenth of a second, so fast that most occupants are not aware that the airbags deployed until they see them lying in their laps.

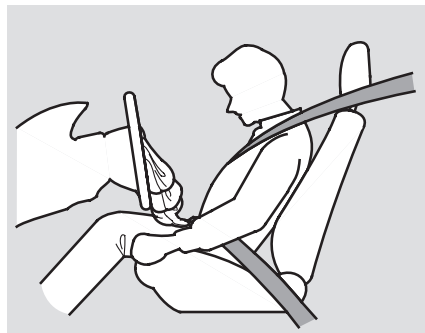

After a crash, you may see what looks like smoke. This is actually powder from the airbag's surface. Although the powder is not harmful, people with respiratory problems may experience some temporary discomfort. If this occurs, get out of the vehicle as soon as it is safe to do so.

*CONTINUED*

## Additional Information About Your Airbags

---

### *Dual-Stage Airbags*

Your front airbags are dual-stage airbags. This means they have two inflation stages that can be ignited sequentially or simultaneously, depending on crash severity.

In a *more severe* crash, both stages will ignite simultaneously to provide the quickest and greatest protection.

In a *less severe* crash, one stage will ignite first, then the second stage will ignite a split second later. This provides longer airbag inflation time with a little less force.

### *Dual-Threshold Airbags*

Your front airbags are also dual-threshold airbags. Airbags with this feature have two deployment thresholds that depend on whether or not the occupant is wearing a seat belt.

If the occupant's belt is *not latched*, the airbag will deploy at the same threshold, because the occupant would need extra protection.

If the occupant's belt *is latched*, the airbag will inflate at a slightly higher threshold, when the airbag would be needed to supplement the protection provided by the seat belt.

### How Your Side Airbags Work (On models equipped)

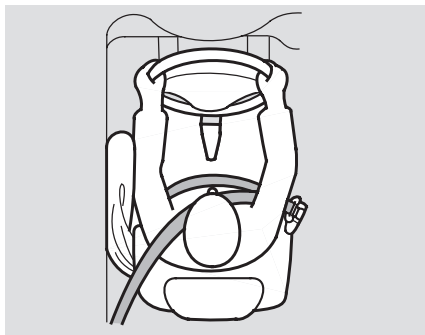

If you ever have a moderate to severe side impact, the sensors will detect rapid deceleration and signal the control unit to instantly inflate either the driver's or the passenger's side airbag.

Only one airbag will deploy during a side impact. If the impact is on the passenger's side, the passenger's side airbag will deploy even if there is no passenger.

To get the best protection from the side airbags, front seat occupants should wear their seat belts and sit upright and well back in their seats.

The passenger's side airbag has a cutoff system designed to turn off the passenger's front airbag if a child's head is in the airbag's deployment path (see page 27).

If the side airbag off indicator comes on, have the passenger sit upright. Once the passenger is out of the deployment path of the side airbag, the system will turn the airbag back on and the indicator will go out.

A front seat passenger should not use a cushion or other object as a backrest. It may prevent the cutoff system from working properly.

# Additional Information About Your Airbags

## How the SRS Indicator Works



The SRS indicator alerts you to a potential problem with your front airbags, side airbags, or front seat belt tensioners.

When you turn the ignition to ON (II), this indicator will come on briefly then go out. This tells you that the system is working properly.

If the indicator comes on at any other time, or does not come on at all, you should have the system checked by your dealer. For example:

- If the SRS indicator does not come on after you turn the ignition switch to ON (II).
- If the indicator stays on after the engine starts.
- If the indicator comes on or flashes on and off while you drive.

If you see any of these indications, the airbags and seat belt tensioners may not work properly when you need them.

## **⚠ WARNING**

Ignoring the SRS indicator can result in serious injury or death if the airbag systems or tensioners do not work properly.

Have your vehicle checked by a dealer as soon as possible if the SRS indicator alerts you to a possible problem.

### How the Side Airbag Off Indicator Works

*(On models equipped)*



This indicator alerts you that the passenger's side airbag has been automatically shut off. It does *not* mean there is a problem with your side airbags.

To reduce the risk of injury from an inflating side airbag, your vehicle has an automatic cutoff system for the passenger's side airbag.

Although Honda does not encourage children to ride in front, this system is designed to shut off the side airbag if a child leans sideways and the child's head is in the side airbag deployment path.

If a short adult leans sideways, or a larger adult slouches and leans sideways into the side airbag deployment path, the system may also shut off the side airbag.

When you turn the ignition switch to ON (II), the indicator should light briefly and go out. If it doesn't light, stays on, or comes on while driving without a passenger in the front seat, have the system checked.

To get the best protection from the side airbags, front seat occupants should wear their seat belts and sit upright and well back in their seats.

# Additional Information About Your Airbags

---

## Airbag Service

Your airbag systems are virtually maintenance-free, and there are no parts you can safely service.

However, you must have your vehicle serviced if:

- ***An airbag ever inflates.*** Any airbag that has deployed must be replaced along with the control unit and other related parts. If a front airbag inflates the seat belt tensioners must also be replaced. Do not try to remove or replace any airbag by yourself. This must be done by a Honda dealer or a knowledgeable body shop.
- ***The SRS indicator light alerts you to a problem.*** Take your vehicle to an authorized Honda dealer as soon as possible. If you ignore this indication, your airbags may not operate properly.

## Additional Safety Precautions

- ***Do not attempt to deactivate your airbags.*** Together, airbags and seat belts provide the best protection.
- ***Do not tamper with airbag components or wiring for any reason.*** Tampering could cause the airbags to deploy, possibly causing very serious injury.
- ***Do not expose the front seat-backs to liquid.*** If water or another liquid soaks into a seat-back, it can prevent the side airbag cutoff system from working properly.

- ***Do not cover or replace front seat-back covers without consulting a Honda dealer.*** Improperly replacing or covering front seat-back covers can prevent your side airbags from inflating during a side impact.

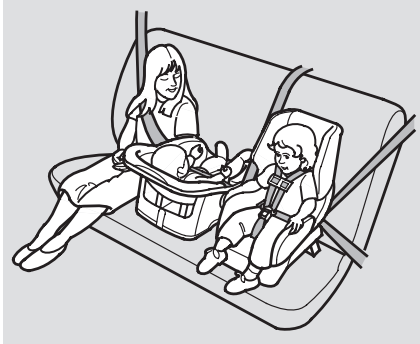

Children depend on adults to protect them. However, despite their best intentions many adults do not know how to properly protect child passengers.

## **⚠ WARNING**

Children who are unrestrained or improperly restrained can be seriously injured or killed in a crash.

Any child too small for a seat belt should be properly restrained in a child seat. A larger child should be properly restrained with a seat belt and use a booster if necessary.

If you have children, or if you ever need to drive with a child in your vehicle, be sure to read this section. It begins with important general guidelines, then presents special information for infants, small children, and larger children.

**All Children Must Be Restrained**  
Each year, many children are injured or killed in vehicle crashes because they are either unrestrained or not properly restrained. In fact, vehicle accidents are the number one cause of death of children ages 12 and under.

To reduce the number of child deaths and injuries, every state and Canadian province requires that infants and children be properly restrained when they ride in a vehicle.

*CONTINUED*



*Infants and small children must be restrained in an approved child seat that is properly secured to the vehicle* (see pages 34 – 35 ).

*Larger children must be restrained with a lap/shoulder belt and ride on a booster until the seat belt fits them properly* (see pages 43 – 46 ).

### **All Children Should Sit in the Back Seat**

According to accident statistics, children of all ages and sizes are safer when they are restrained in the back seat. The National Highway Traffic Safety Administration and Transport Canada recommend that all children age 12 and under be properly restrained in the back seat.

Children who ride in back are less likely to be injured by striking interior vehicle parts during a collision or hard braking. Also, children cannot be injured by an inflating airbag when they ride in the back.

### **The Passenger's Front Airbag Can Pose Serious Risks**

Front airbags have been designed to help protect adults in a moderate to severe frontal collision. To do this the passenger's front airbag is quite large and it can inflate with enough force to cause very serious injuries.

### **Infants**

*Never put a rear-facing child seat in the front seat of a vehicle equipped with a passenger's front airbag.* If the airbag inflates, it can hit the back of the child seat with enough force to kill or very seriously injure an infant.

### **Small Children**

*Placing a forward-facing child seat in the front seat of a vehicle equipped with passenger's front airbag can be hazardous.* If the vehicle seat is too far forward, or the child's head is thrown forward during a collision, an inflating front airbag can strike the child with enough force to kill or very seriously injure a small child.

### **Larger Children**

*Children who have outgrown child seats are also at risk of being injured or killed by an inflating passenger's front airbag.* Whenever possible, larger children should sit in the back seat, in a booster seat if needed, and be properly restrained with a seat belt (see page 43 for important information about protecting larger children).

## *U.S. Models*

To remind you of the passenger's front airbag hazards, and that children must be properly restrained in the back seat, your vehicle has warning labels on the dashboard and on the driver's and front passenger's visors. Please read and follow the instructions on these labels.



## *Canadian Models*

To remind you of the front airbag hazards, your vehicle has warning labels on the driver's and front passenger's visors. Please read and follow the instructions on these labels.

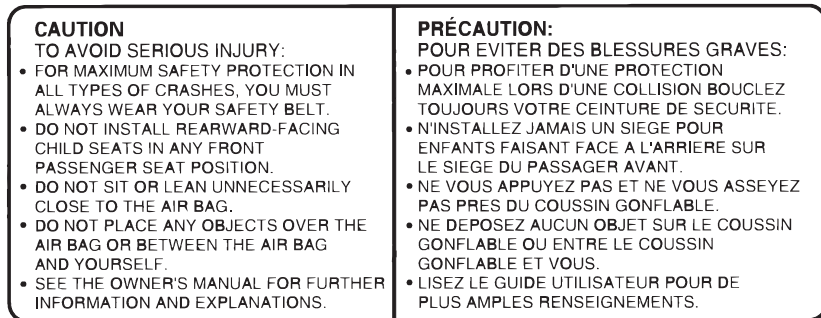

### **If You Must Drive with Several Children**

Your vehicle has three seating positions in the back seat where children can be properly restrained. If you ever have to carry more than three children, and a child must ride in front:

- Place the largest child in the front seat, provided the child is large enough to wear the lap/shoulder belt properly (see page [44](#) ).
- Move the vehicle seat as far to the rear as possible (see page [11](#) ).
- Have the child sit upright and well back in the seat (see page [30](#) ).
- Make sure the seat belt is properly positioned and secured (see page [14](#) ).

### **If a Child Requires Close Attention**

Many parents say they prefer to put an infant or small child in the front passenger seat so they can watch the child, or because the child requires attention.

Placing a child in the front seat exposes the child to hazards in a frontal collision, and paying close attention to a child distracts the driver from the important tasks of driving, placing both of you at risk.

If a child requires physical attention or frequent visual contact, we strongly recommend that another adult ride with the child in the back seat. The back seat is far safer for a child than the front.

### Additional Safety Precautions

- Never hold an infant or child on your lap. If you are not wearing a seat belt in crash, you could be thrown forward and crush the child against the dashboard or a seat-back. If you are wearing a seat belt the child can be torn from your arms and be seriously hurt or killed.
  - Never put a seat belt over yourself and a child. During a crash, the belt could press deep into the child and cause serious or fatal injuries.
  - Never let two children use the same seat belt. If they do, they could be very seriously injured in a crash.
  - Use childproof door locks to prevent children from opening the doors. This can prevent children from accidentally falling out.
- Do not leave children alone in a vehicle. Leaving children without adult supervision is illegal in most states and Canadian provinces, and can be very hazardous. For example, infants and small children left in a vehicle on a hot day can die from heatstroke. A child left alone with the key in the ignition can accidentally set the vehicle in motion, possibly injuring themselves or others.
  - Lock both doors and the trunk when your vehicle is not in use. Children who play in vehicles can accidentally get trapped inside the trunk. Teach your children not to play in or around vehicles. Know how to operate the emergency trunk opener and decide if your children should be shown how to use this feature (see page 73 ).
- Keep vehicle keys and remote transmitters out of the reach of children. Even very young children learn how to unlock vehicle doors, turn on the ignition, and open the trunk, which can lead to accidental injury or death.

# Protecting Infants and Small Children

## Protecting Infants

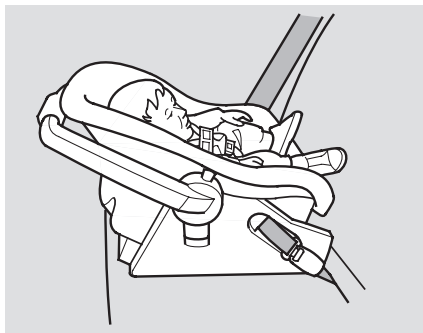

### *Child Seat Type*

Only a rear-facing child seat provides proper support for a baby's head, neck, and back.

An infant must be properly restrained in a rear-facing, reclining child seat until the child reaches the seat maker's weight or height limit for the seat, and the child is at least one year old.

## **⚠ WARNING**

Placing a rear-facing child seat in the front seat can result in serious injury or death if the passenger's front airbag inflates.

Always place a rear-facing child seat in the back seat, not the front.

Two types of seats may be used: a seat designed exclusively for infants, or a convertible seat used in the rear-facing, reclining mode.

***Do not put a rear-facing child seat in a forward-facing position.*** If placed facing forward, an infant could be very seriously injured during a frontal collision.

### *Child Seat Placement*

In this vehicle, a rear-facing child seat can be placed in any seating position in the back seat, but not in the front.

***Never put a rear-facing child seat in the front seat.*** If the passenger's front airbag inflates, it can hit the back of the child seat with enough force to kill or seriously injure an infant.

When properly installed, a rear-facing child seat may prevent the driver or a front passenger from moving the seat as far back as recommended, or from locking the seat-back in the desired position. In either of these situations, we strongly recommend that you install the child seat directly behind the front passenger seat, move the front seat as far forward as needed, and leave it unoccupied. Or you may wish to get a smaller child seat that allows you to safely carry a front passenger.

## Protecting Small Children



### *Child Seat Type*

A child who is at least one year old, and who fits within the child seat maker's weight and height limits, should be restrained in a forward-facing, upright child seat.

Of the different seats available, we recommend those that have a five-point harness system as shown.

We also recommend that a small child stay in the child seat as long as possible, until the child reaches the weight or height limit for the seat.

### *Child Seat Placement*

We strongly recommend placing a forward-facing child seat in a back seat, not the front.

***Placing a forward-facing child seat in the front seat of a vehicle equipped with a passenger's airbag can be hazardous.*** If the vehicle seat is too far forward, or the child's head is thrown forward during a collision, an inflating airbag can strike the child with enough force to cause very serious or fatal injuries.

If it is necessary to put a forward-facing child seat in the front, move the vehicle seat as far to the rear as possible, be sure the child seat is firmly secured to the vehicle, and the child is properly strapped in the seat.

## **⚠ WARNING**

Placing a forward-facing child seat in the front seat can result in serious injury or death if the front airbag inflates.

If you must place a forward-facing child seat in front, move the vehicle seat as far back as possible, and properly restrain the child.

## Selecting a Child Seat

---

When buying a child seat, you need to choose between a conventional child seat, or one designed for use with the Lower Anchors and Tethers for Children (LATCH) system.

Conventional child seats must be secured to a vehicle with a seat belt, whereas LATCH-compatible seats are secured by attaching the seat to hardware built into the two outer seating positions in the back seat.

Since LATCH-compatible child seats are easier to install and reduce the possibility of improper installation, we recommend selecting this style.

We also recommend selecting a LATCH-compatible seat with a rigid, rather than a flexible, anchor (see page 38 ).

In seating positions and vehicles not equipped with LATCH, a LATCH-compatible child seat can be installed using a seat belt.

Whatever type of seat you choose, to provide proper protection, a child seat should meet three requirements:

- 1. The child seat should meet U.S. or Canadian Motor Vehicle Safety Standard 213.*** Look for FMVSS 213 or CMVSS 213 on the box.
- 2. The child seat should be of the proper type and size to fit the child.*** Rear-facing for infants, forward-facing for small children.
- 3. The child seat should fit the vehicle seating position (or positions) where it will be used.***

Before purchasing a conventional child seat, or using a previously purchased one, we recommend that you test the seat in the specific vehicle seating position, or positions, where the seat will be used.

After selecting a proper child seat, and a good place to install the seat, there are three main steps in installing the seat:

**1. Properly secure the child seat to the vehicle.** All child seats must be secured to the vehicle with the lap part of a lap/shoulder belt or with the LATCH (Lower Anchors and Tethers for Children) system. A child whose seat is not properly secured to the vehicle can be endangered in a crash.

**2. Make sure the child seat is firmly secured.** After installing a child seat, push and pull the seat forward and from side to side to verify that it is secure.

A child seat secured with a seat belt should be installed as firmly as possible. However, it does not need to be “rock solid”. Some side-to-side movement can be expected and should not reduce the child seat’s effectiveness.

If the child seat is not secure, try installing it in a different seating position, or use a different style of child seat that can be firmly secured.

**3. Secure the child in the back seat.** Make sure the child is properly strapped in the child seat according to the child seat maker’s instructions. A child who is not properly secured in a child seat can be seriously injured in a crash.

The following pages provide guidelines on how to properly install a child seat. A forward-facing child seat is used in all examples, but the instructions are the same for rear-facing child seat.



# Installing a Child Seat

## Installing a Child Seat Using LATCH

Your vehicle is equipped with LATCH (Lower Anchors and Tethers for Children) at the outer rear seats. The lower anchors are located between the seat-back and seat bottom, and are to be used only with a child seat designed for use with LATCH.

Small marks are positioned to indicate the locations of each anchor point.

To install a LATCH-compatible child seat:

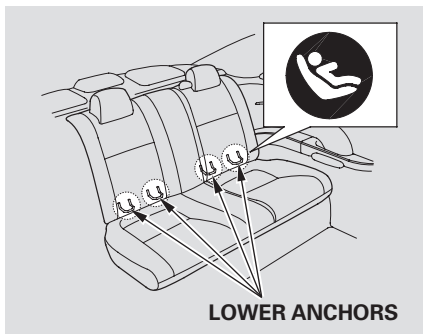

1. Move the seat belt buckle or tongue away from the lower anchors.
2. Make sure there are no objects near the anchors that could prevent a secure connection between the child seat and anchors.

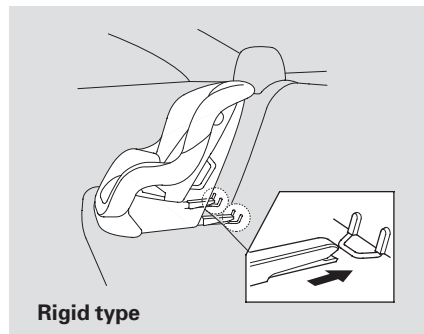

3. Place the child seat on the vehicle seat, and attach the seat to the lower anchors according to the child seat maker's instructions.

Some LATCH-compatible seats have a rigid-type connection as shown above.

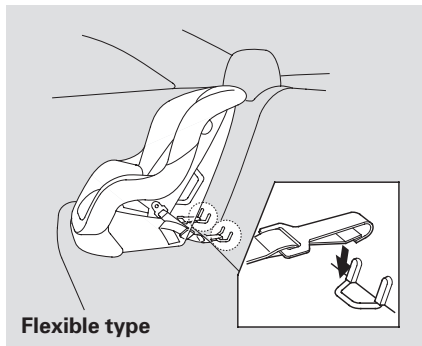

Other LATCH-compatible seats have a flexible-type connection as shown above.

4. Whatever type you have, follow the child seat maker's instructions for adjusting or tightening the fit.

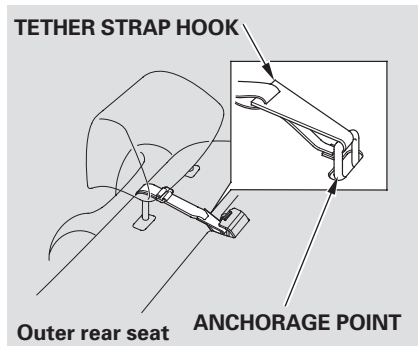

5. Route the tether strap over the seat-back, making sure the strap is not twisted.
6. Attach the tether strap hook to the tether anchorage point, then tighten the strap as instructed by the child seat maker.
7. Push and pull the child seat forward and from side-to-side to verify that it is secure.

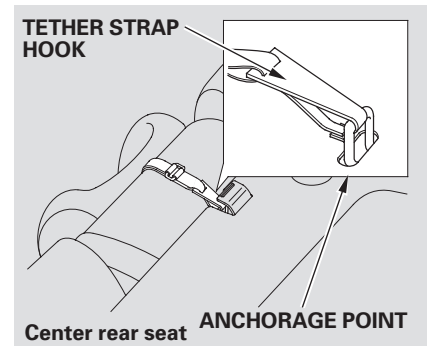

# Installing a Child Seat

## Installing a Child Seat with a Lap/Shoulder Belt

When not using the LATCH system, all child seats must be secured to the vehicle with the lap part of a lap/shoulder belt.

In addition, the lap/shoulder belts in the back seating positions, and in the front passenger seat, have a locking mechanism that must be activated to secure a child seat.

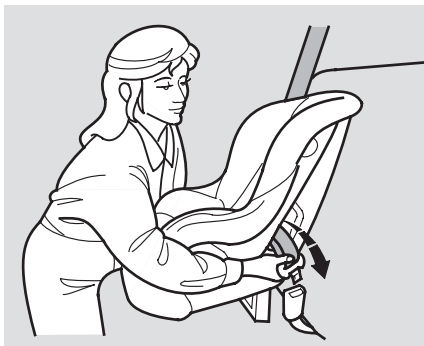

1. With the child seat in the desired seating position, route the belt through the child seat according to the seat maker's instructions, then insert the latch plate into the buckle.

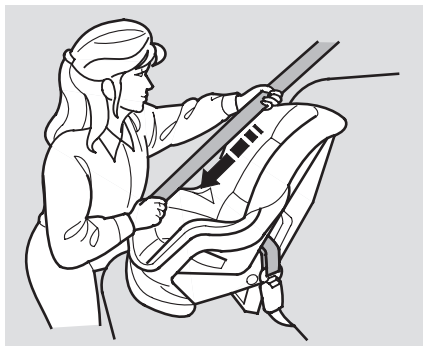

2. To activate the lockable retractor, slowly pull the shoulder part of the belt all the way out until it stops, then let the belt feed back into the retractor.
3. After the belt has retracted, tug on it. If the belt is locked, you will not be able to pull it out. If you can pull the belt out, it is not locked, and you will need to repeat these steps.



4. After confirming that the belt is locked, grab the shoulder part of the belt near the buckle and pull up to remove any slack from the lap part of the belt. Remember, if the lap part of the belt is not tight, the child seat will not be secure.

To remove slack, it may help to put weight on the child seat, or push on the back of the seat while pulling up on the belt.

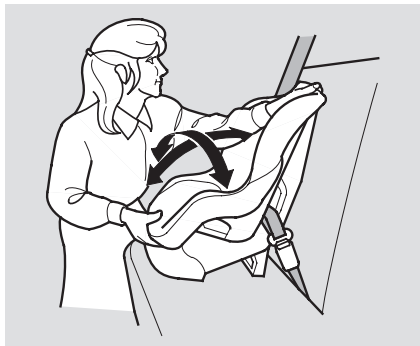

5. Push and pull the child seat forward and from side to side to verify that it is firmly secured. If the child seat is not secure, unlatch the belt, allow it to retract fully, then repeat these steps.

To deactivate the locking mechanism and remove a child seat, unlatch the buckle, unrout the seat belt, and let the belt fully retract.

# Installing a Child Seat

## Installing a Child Seat with a Tether

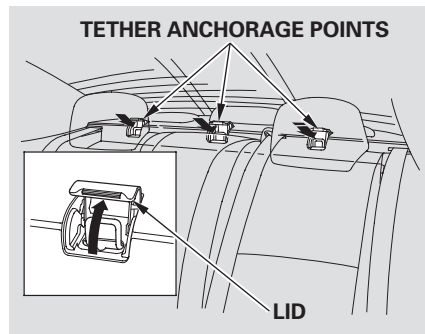

A child seat with a tether can be installed in any seating position in the back seat, using one of the anchorage points shown above.

Since a tether can provide additional security to the lap/shoulder belt installation, we recommend using a tether whenever one is required or available. (Tethers are required in Canada.)

## Using an Outer Anchorage Point

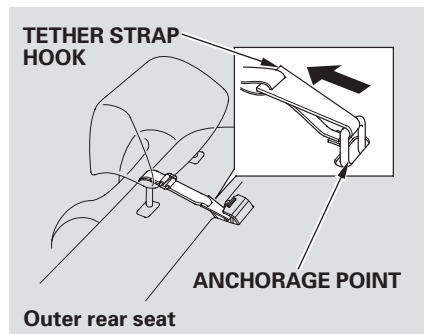

1. After securing the child seat in the desired position (see page 40), lift the head restraint, then route the tether strap over the top of the seat-back and through the head restraint legs.

2. Lift the anchor point lid, then attach the tether strap hook to the anchorage point, making sure the strap is not twisted.
3. Tighten the strap according to the seat maker's instructions.

## Using the Center Anchorage Point

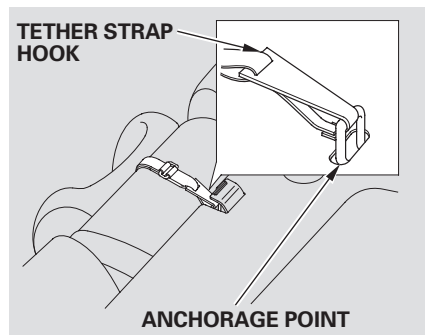

1. After properly securing the child seat with the lap/shoulder belt (see page 40), route the tether strap over the top of the seat-back.
2. Attach the tether strap hook to the anchorage point, making sure the strap is not twisted, then tighten the strap according to the seat-maker's instructions.

## Protecting Larger Children

When a child reaches the recommended weight or height limit for a forward-facing child seat, the child should sit in a back seat on a booster and wear a lap/shoulder belt.

The following pages give instructions on how to check proper seat belt fit, what kind of booster seat to use if one is needed, and important precautions for a child who must sit in front.

## **⚠ WARNING**

Allowing a large child age 12 or under to sit in front can result in injury or death if the passenger's front airbag inflates.

If a large child must ride in front, move the vehicle seat as far back as possible, use a booster seat if needed, have the child sit up properly and wear the seat belt properly.

# Protecting Larger Children

## Checking Seat Belt Fit



To determine if a lap/shoulder belt properly fits a child, have the child put on the seat belt, then ask yourself:

1. Does the child sit all the way back against the seat?
2. Do the child's knees bend comfortably over the edge of the seat?

3. Does the shoulder belt cross between the child's neck and arm?
4. Is the lap part of the belt as low as possible, touching the child's thighs?
5. Will the child be able to stay seated like this for the whole trip?

If you answer yes to all these questions, the child is ready to wear the lap/shoulder belt correctly. If you answer no to any question, the child needs to ride on a booster seat.

## Using a Booster Seat



A child who has outgrown a forward-facing child seat should ride in a back seat and use a booster seat until the lap/shoulder belt fits them properly without the booster.

Some states also require children to use a booster until they reach a given age or weight (e.g., 6 years or 60 lbs). Be sure to check current laws in the state or states where you intend to drive.

Booster seats can be high-back or low-back. Whichever style you select, make sure the booster meets federal safety standards and that you follow the booster seat maker's instructions.

If a child who uses a booster must be in front, move the vehicle seat as far back as possible and be sure the child is wearing the seat belt properly.

A child may continue using a booster seat until the tops of their ears are even with the top of the vehicle's or booster's seat-back. A child of this height should be tall enough to use the lap/shoulder belt without a booster.

*When Can a Larger Child Sit in Front*  
The National Highway Traffic Safety Administration and Transport Canada recommend that all children ages 12 and under be properly restrained in the back seat.

The back seat is the safest place for a child of any age or size.

If the passenger's front airbag inflates in a moderate to severe frontal collision, the airbag can cause serious injuries to a child who is unrestrained, improperly restrained, sitting too close to the airbag, or out of position.

The side airbag also poses risks. If any part of a larger child's body is in the path of a deploying side airbag, the child could receive possibly serious injuries.

*CONTINUED*



# Protecting Larger Children

---

Of course, children vary widely. And while age may be one indicator of when a child can safely ride in front. There are other important factors you should consider.

## *Maturity*

To safely ride in front, a child must be able to follow the rules, including sitting properly, and wearing the seat belt properly throughout a ride.

## *Physical Size*

Physically, a child must be large enough for the lap/shoulder belt to properly fit (see page 44). If the seat belt does not fit properly, with or without the child sitting on a booster, the child should not sit in front.

If you decide that a child can safely ride up front, be sure to:

- Carefully read the owner's manual and make sure you understand all seat belt instructions and all safety information.
- Move the vehicle seat to the rear-most position.
- Have the child sit up straight, back against the seat, and feet on or near the floor.
- Check that the child's seat belt is properly positioned and secured.
- Remind the child not to lean toward the door.
- Supervise the child. Even mature children sometimes need to be reminded to fasten the seat belts or sit properly.

## **Additional Safety Precautions**

***Do not let a child wear a seat belt across the neck.*** This could result in serious neck injuries during a crash.

***Do not let a child put the shoulder part of a seat belt behind the back or under the arm.*** This could cause very serious injuries during a crash. It also increases the chance that the child will slide under the belt in a crash and be injured.

***Two children should never use the same seat belt.*** If they do, they could be very seriously injured in a crash.

***Do not put any accessories on a seat belt.*** Devices intended to improve a child's comfort or reposition the shoulder part of a seat belt can make the belt less effective, and increase the chance of serious injury in a crash.

Your vehicle's exhaust contains carbon monoxide gas. You should have no problem with carbon monoxide entering the vehicle in normal driving if you maintain your vehicle properly.

Have the exhaust system inspected for leaks whenever:

- The vehicle is raised for an oil change.
- You notice a change in the sound of the exhaust.
- The vehicle was in an accident that may have damaged the underside.

### **WARNING**

Carbon monoxide gas is toxic. Breathing it can cause unconsciousness and even kill you.

Avoid any enclosed areas or activities that expose you to carbon monoxide.

High levels of carbon monoxide can collect rapidly in enclosed areas, such as a garage. Do not run the engine with the garage door closed. Even with the door open, run the engine only long enough to move the vehicle out of the garage.

With the trunk lid open, air flow can pull exhaust gas into your vehicle's interior and create a hazardous condition. If you must drive with the trunk lid open, open all the windows and set the heating and cooling system as shown below.

If you must sit in your parked vehicle, even in an unconfined area, with the engine running, adjust the heating and cooling system as follows:

1. Select the Fresh Air mode.
2. Select the  mode.
3. Turn the fan on high speed.
4. Set the temperature control to a comfortable setting.

# Safety Labels

These labels are in the locations shown. They warn you of potential hazards that could cause serious injury. Read these labels carefully. If a label comes off or becomes hard to read, contact your Honda dealer for a replacement.

## RADIATOR CAP



## DASHBOARD

*U.S. models only*

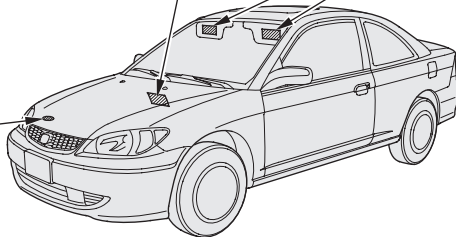

## SUN VISOR

*U.S. models*



## Canadian models

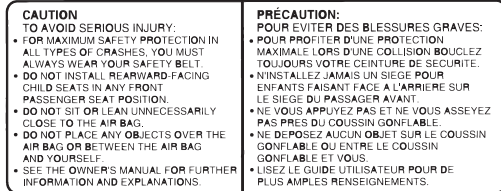

## HOOD

*On models without side airbags*

### **▲ WARNING**

**The airbag inflator is explosive and, if accidentally deployed, can seriously hurt you.**

**Follow Service Manual instructions carefully.**

### **▲ ATTENTION**

**Le gonfleur SRS est explosible, et s'il se déploie accidentellement, il risque de provoquer des blessures graves ou de tuer. Suivre attentivement les instructions du manuel d'entretien.**

*On models with side airbags*

### **▲ WARNING**

Accidental deployment can seriously hurt or kill you.  
Follow Service Manual instructions carefully.

### **▲ ATTENTION**

Un déploiement accidentel risque de causer graves blessures, voire la mort.  
Suivre attentivement les instructions du manuel de réparation.

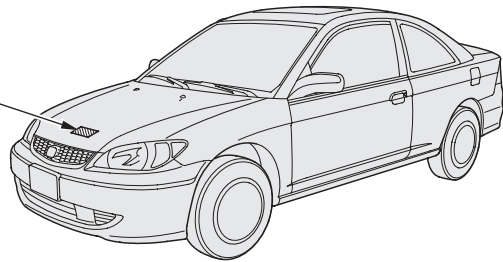



This section gives information about the controls and displays that contribute to the daily operation of your Honda. All the essential controls are within easy reach.

Control Locations .....	52	Moonroof .....	82
Instrument Panel .....	53	Mirrors .....	83
Instrument Panel Indicators.....	56	Parking Brake .....	84
Gauges .....	60	Interior Lights.....	85
Odometer/Trip Meter .....	60	Ceiling Light.....	85
Fuel Gauge .....	60	Individual Interior Lights.....	85
Temperature Gauge .....	61	Interior Convenience Items.....	86
Maintenance Required Indicator ..	62	Beverage Holders.....	87
Controls Near the Steering		Globe Box .....	87
Wheel .....	63	Console Compartment .....	87
Windshield Wipers and Washers ..	64	Center Pocket .....	88
Turn Signal and Headlights.....	65	Accessory Power Socket .....	88
Instrument Panel Brightness .....	66	Vanity Mirror .....	88
Hazard Warning Button.....	67		
Rear Window Defogger .....	67		
Steering Wheel Adjustment .....	68		
Keys and Locks.....	69		
Immobilizer System.....	70		
Ignition Switch .....	71		
Door Locks .....	72		
Power Door Locks.....	72		
Trunk .....	72		
Emergency Trunk Opener .....	73		
Remote Transmitter .....	74		
Seats .....	76		
Power Windows .....	81		

# Control Locations

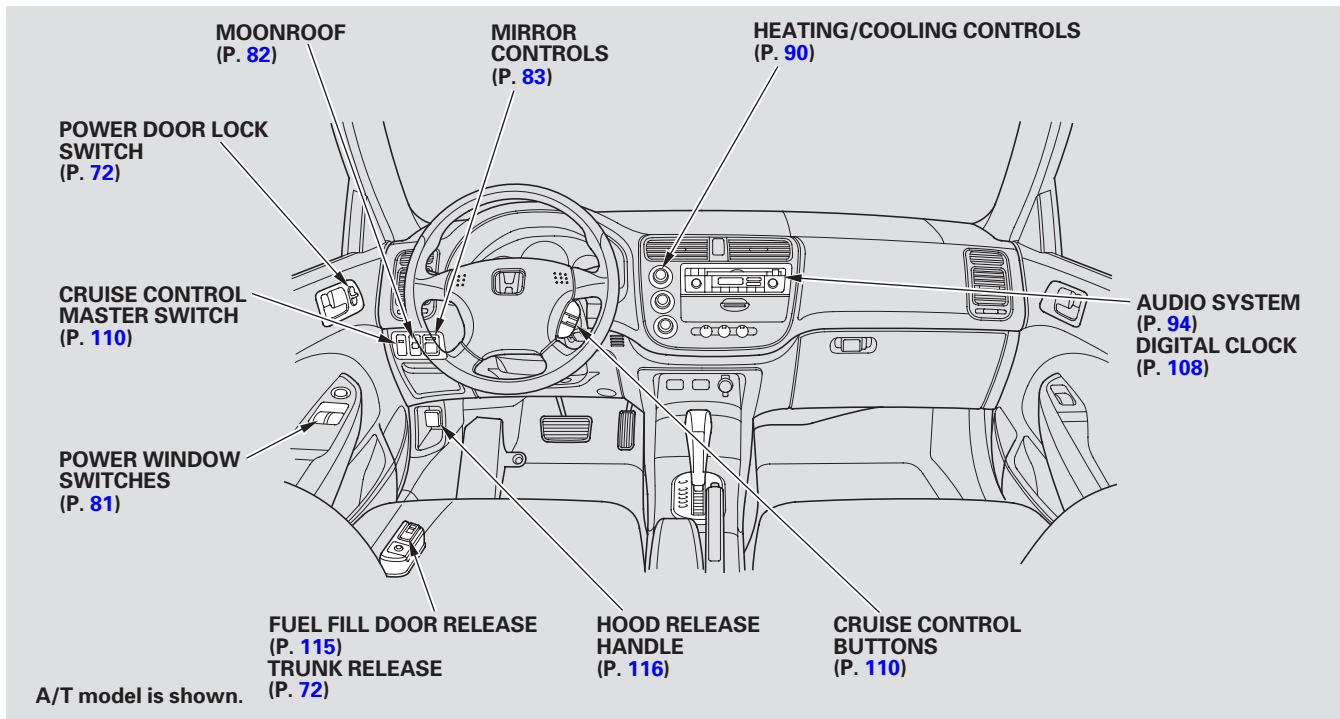

U.S.: HX, LX, EX, Canada: LX, Si

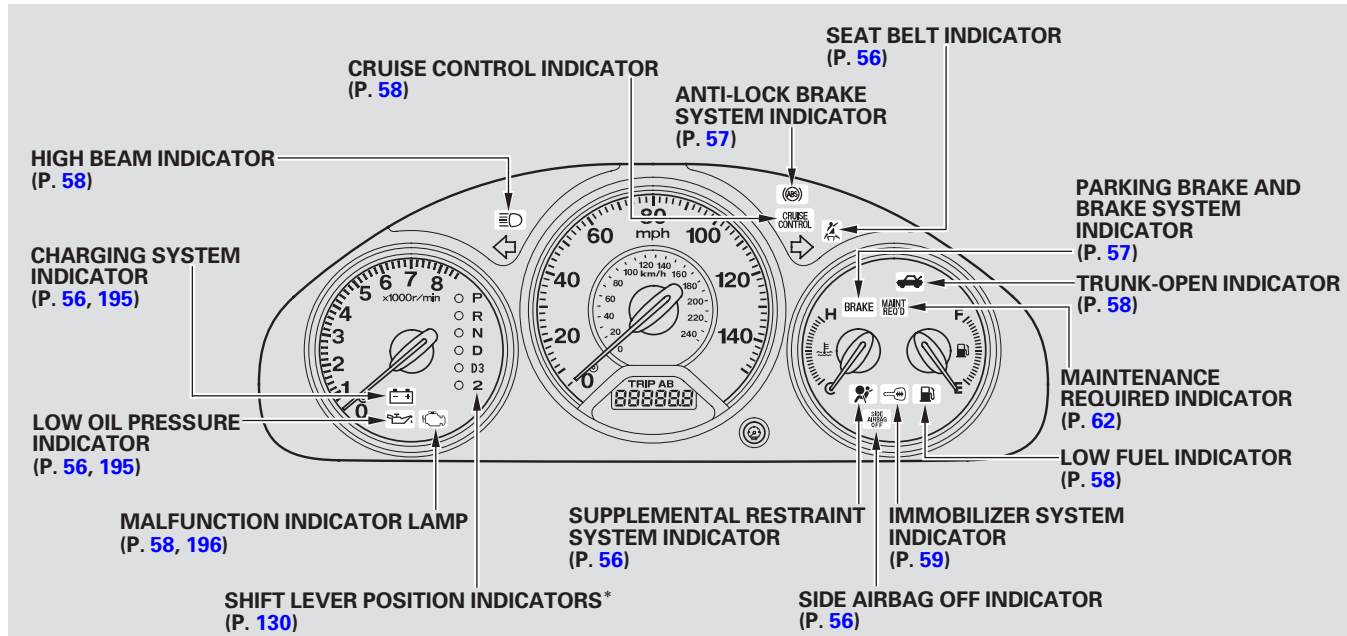

The U.S. instrument panel is shown. Differences for the Canadian models are noted in the text.

\* Shift Lever Position Indicator for the HX is shown on page 134 .

CONTINUED



# Instrument Panel

Canada: DX

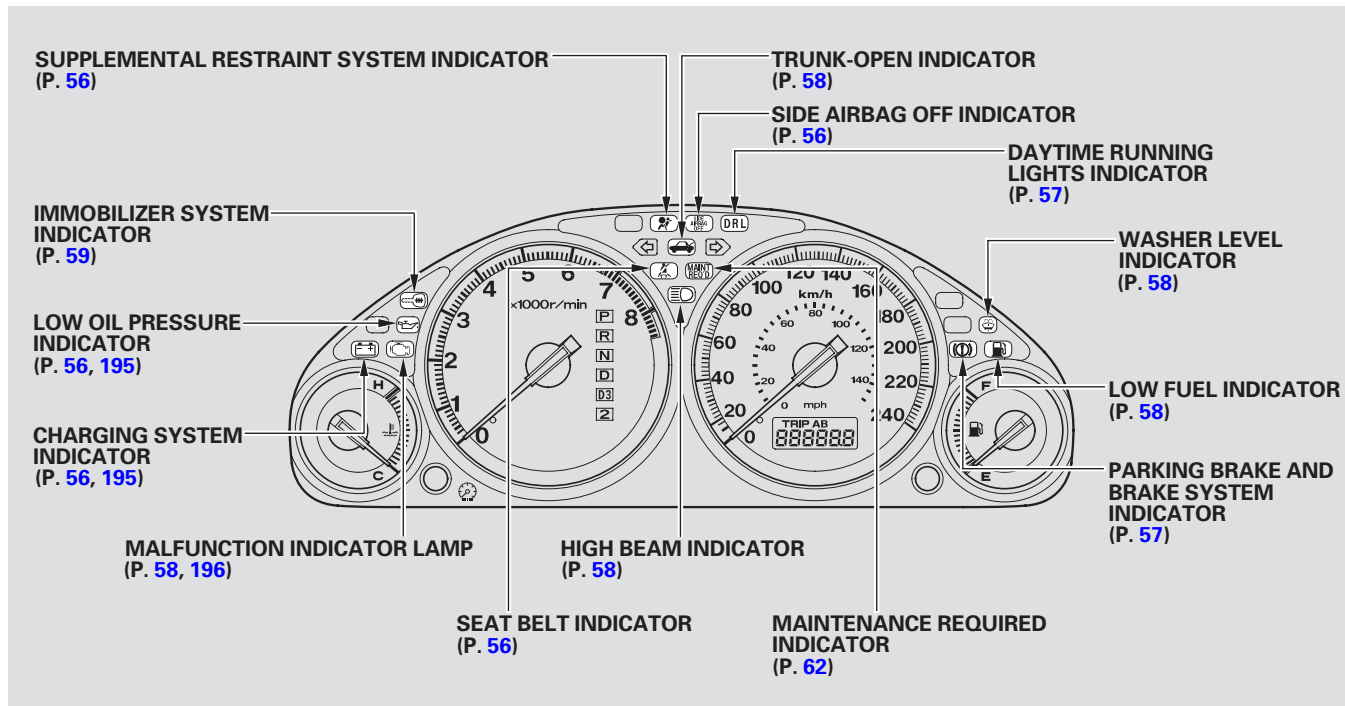

U.S.: DX

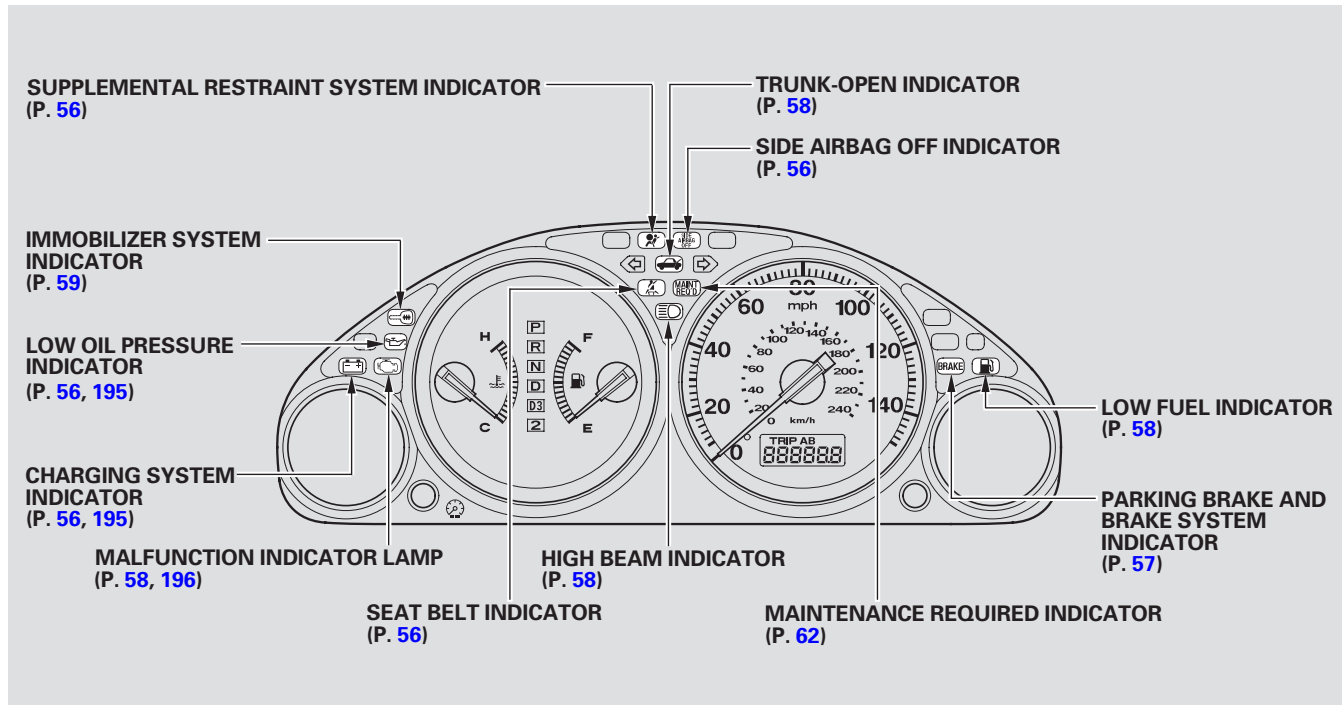

# Instrument Panel Indicators

The instrument panel has many indicators to give you important information about your vehicle.



## Seat Belt Indicator

The seat belt system includes an indicator on the instrument panel and a beeper to remind you and your passengers to fasten your seat belts.

If you turn the ignition switch to ON (II) before fastening your belt, the beeper sounds and the indicator flashes. If you do not fasten your seat belt before the beeper stops, the indicator stops flashing but remains on.

If you continue driving without fastening your seat belt, the beeper sounds and the indicator flashes again at regular intervals.



## Supplemental Restraint System Indicator

This indicator comes on when you turn the ignition switch to ON (II). If it comes on at any other time, it indicates a potential problem with your front airbags or automatic seat belt tensioners. On models equipped with side airbags, this light will also alert you to a potential problem with your side airbags or passenger's side airbag automatic cutoff system. For complete information, see page [26](#).



## Side Airbag Off Indicator

*Only on models equipped with side airbags*

This indicator comes on when you turn the ignition switch to ON (II). If it comes on at any other time, it indicates that the passenger's side airbag has automatically shut off. For more information, see page [27](#).



## Charging System Indicator

If this indicator comes on when the engine is running, the battery is not being charged. For more information, see page [195](#).



## Low Oil Pressure Indicator

The engine can be severely damaged if this indicator flashes or stays on when the engine is running. For complete information, see page [195](#).



## Parking Brake and Brake System Indicator

This indicator has two functions:

1. It comes on when you turn the ignition switch ON (II). It is a reminder to check the parking brake. Driving with the parking brake not fully released can damage the brakes and tires.
2. If it remains lit after you have fully released the parking brake while the engine is running, or if it comes on while driving, there could be a problem with the brake system. For complete information, see page [197](#).



## Anti-lock Brake System (ABS) Indicator

*Only on models equipped with ABS (see page [139](#))*

This indicator normally comes on for a few seconds when you turn the ignition switch to ON (II), and when the ignition switch is turned to START (III). If this indicator comes on at any other time, there is a problem in the ABS. If this happens, take your vehicle to your dealer to have it checked. With this indicator on, your vehicle still has normal braking ability but no anti-lock. For complete information, see page [139](#).



## “Daytime Running Lights” Indicator

*Canadian models only*

This indicator comes on when you turn the ignition switch to ON (II) with the headlight switch off and the parking brake set. It should go off if you turn on the headlights or release the parking brake. If it comes on at any other time, it means there is a problem with the DRL. There may also be a problem with the high beam headlights.

*CONTINUED*

# Instrument Panel Indicators

---



## Malfunction Indicator Lamp

See page [196](#).



## Turn Signal and Hazard Warning Indicators

The left or right turn signal indicator blinks when you signal a lane change or turn. If the indicator does not blink or blinks rapidly, it usually means one of the turn signal bulbs is burned out (see page [166](#)). Replace the bulb as soon as possible, since other drivers cannot see that you are signaling.

When you turn on the Hazard Warning switch, both turn signal lights blink. All turn signals on the outside of the vehicle should flash.



## High Beam Indicator

This indicator comes on with the high beam headlights. See page [73](#) for information on the headlight controls.

On Canadian models, this indicator comes on with reduced brightness when the Daytime Running Lights (DRL) are on (see page [65](#)).



## Cruise Control Indicator

*Only on models equipped with Cruise Control System*

This indicator comes on when you set the cruise control. See page [110](#) for information on operating the cruise control.



## Trunk-open Indicator

This indicator comes on if the trunk lid is not closed tightly.



## Low Fuel Indicator

This indicator comes on as a reminder that you must refuel soon.



## Washer Level Indicator

*Canadian models only*

This indicator comes on when the washer fluid level is low. Add washer fluid when you see this indicator comes on (see page [156](#)).



## **Immobilizer System Indicator**

This indicator comes on for a few seconds when you turn the ignition switch to ON (II). It will go off if you have inserted a properly-coded ignition key. If it is not a properly-coded key, the indicator will blink and the engine will not start (see page [70](#) ).

This indicator also blinks several times when you turn the ignition switch from ON (II) to ACCESSORY (I) or LOCK (0).

U.S.: HX, LX, EX, Canada: LX, Si

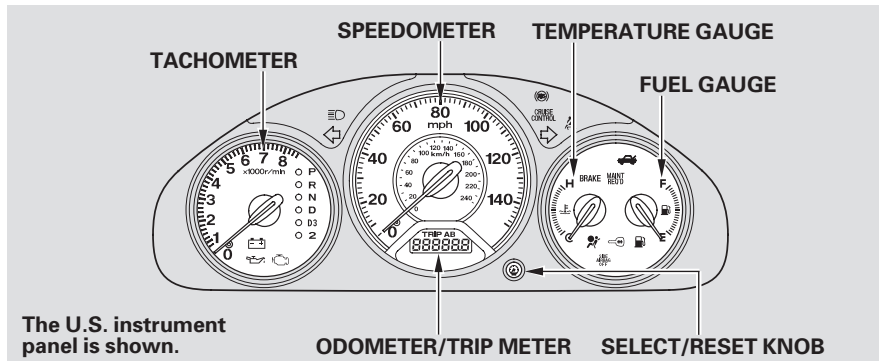

## Odometer/Trip Meter

The odometer shows the total distance your vehicle has been driven. It measures miles in U.S. models and kilometers in Canadian models. It is illegal under U.S. federal law and Canadian provincial regulations to disconnect, reset, or alter the odometer with the intent to change the number of miles or kilometers indicated.

The odometer and the trip meters use the same display. Switch between these displays by pressing the Select/Reset knob.

The trip meter shows the number of miles (U.S.) or kilometers (Canada) driven since you last reset it.

There are two trip meters: Trip A and Trip B. Each trip meter works independently, so you can keep track of two different distances.

To reset a trip meter, display it and then press and hold the Select/Reset knob until the number resets to "0.0".

## Fuel Gauge

This shows how much fuel you have. It may show slightly more or less than the actual amount. The needle returns to the bottom after you turn off the ignition.

### NOTICE

*Avoid driving with an extremely low fuel level. Running out of fuel could cause the engine to misfire, damaging the catalytic converter.*

## U.S. DX

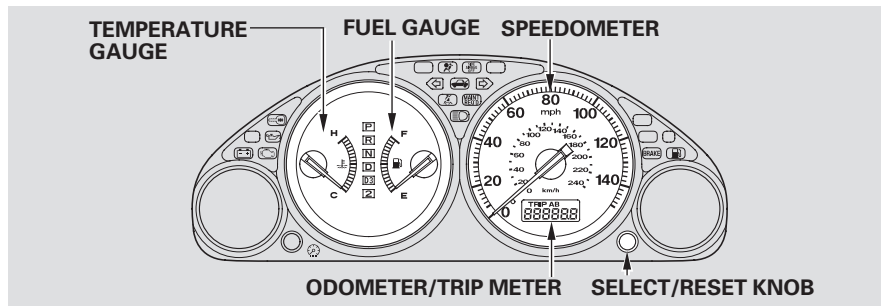

## Canadian DX

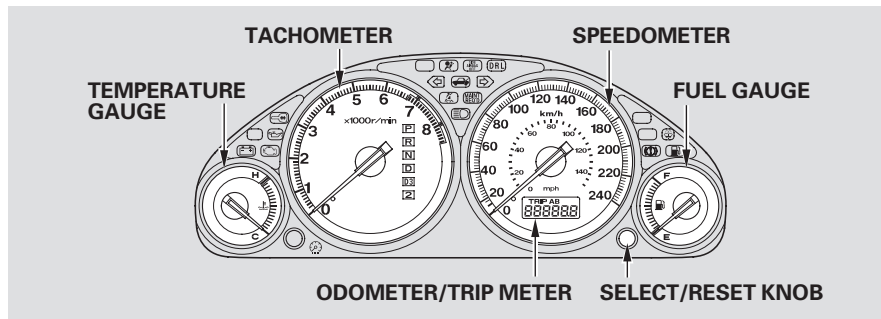

## Temperature Gauge

This shows the temperature of the engine's coolant. During normal operation, the pointer should rise to about the middle of the gauge. In severe driving conditions, the pointer may rise to the upper zone. If it reaches the red (Hot) mark, pull safely to the side of the road. Turn to page 157 for instructions and precautions on checking the engine's cooling system.



# Maintenance Required Indicator

**MAINT  
REQ'D**

## Maintenance Required Indicator

This indicator reminds you that it is time to take your vehicle in for scheduled maintenance.

Refer to the Maintenance Schedules for Normal and Severe Driving Conditions on pages [145](#) and [147](#).

For the first 8,000 miles (12,800 km) after the Maintenance Required Indicator is reset, it will come on for two seconds when you turn the ignition switch to ON (II).

Between 8,000 miles (12,800 km) and 10,000 miles (16,000 km), this indicator will light for two seconds when you first turn the ignition switch to ON (II), and then flash for ten seconds.

If you exceed 10,000 miles (16,000 km) without having the scheduled maintenance performed, this indicator will remain on as a constant reminder.

Your dealer will reset this indicator after completing the scheduled maintenance. If this maintenance is done by someone other than your Honda dealer, reset the indicator as follows.

1. Turn off the engine.

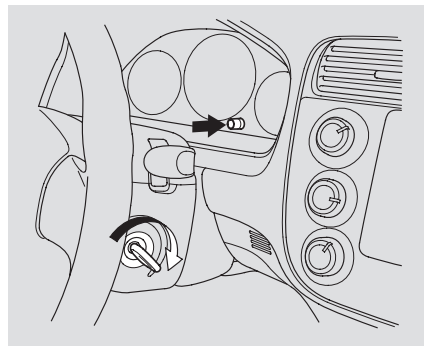

2. Press and hold the Select/Reset knob in the instrument panel, then turn the ignition switch to ON (II).
3. Hold the knob for about ten seconds until the light goes off.

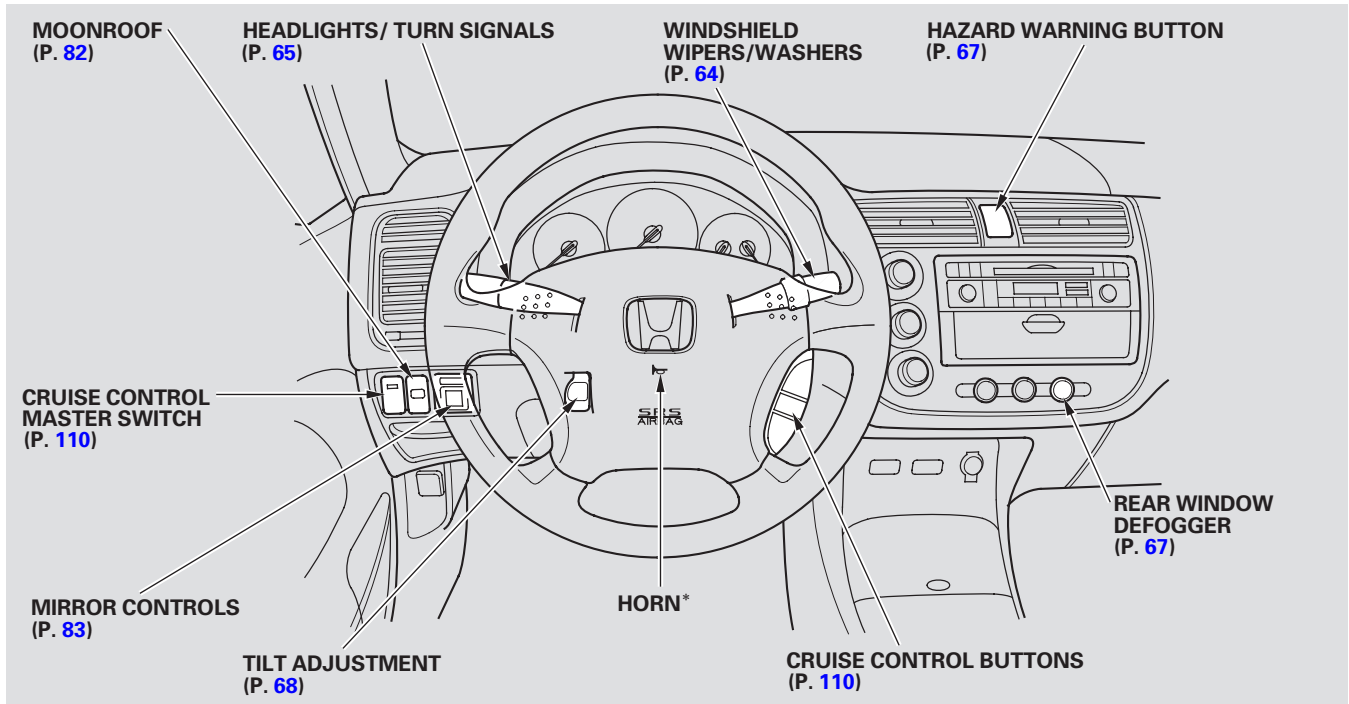

\* To use the horn, press the center pad of the steering wheel.

# Windshield Wipers and Washers

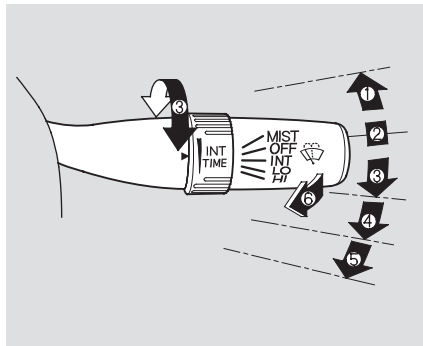

1. MIST
2. OFF
3. INT – Intermittent
4. LO – Low
5. HI – High
6. Windshield Washers

Push the right lever up or down to select a position.

**MIST** – The wipers run at high speed until you release the lever.

**OFF** – The wipers are not activated.

**INT** – The length of the wipe interval is varied automatically according to vehicle's speed.

*On EX model in U.S., and Si models in Canada*

Vary the delay by turning the INT TIME ring.

**LO** – The wipers run at low speed.

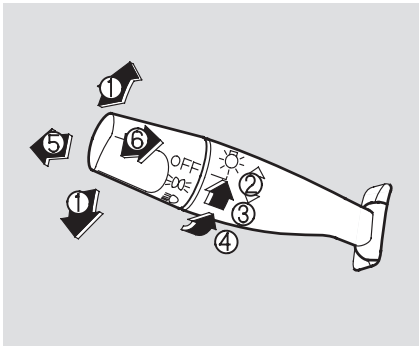

**HI** – The wipers run at high speed.

**Windshield Washer** – Pull the wiper control lever toward you and hold it. The washers spray until you release the lever. The wipers run at low speed, then complete one more sweep after you release the lever.



1. Turn Signal
2. Off
3. Parking and indicator lights
4. Headlights on
5. High beams
6. Flash high beams

**Turn Signal** — Push down on the left lever to signal a left turn and up to signal a right turn. To signal a lane change, push lightly on the lever in the proper direction and hold it. The lever will return to center when you release it or complete a turn.

**Headlights On** — Rotating switch on the left lever controls to the “ ” position turns on the parking lights, taillights, instrument panel lights, side-marker lights, and rear license plate lights. Turning the switch to the “ ” position turns on the headlights. If you leave the lights on with the key removed from the ignition switch, you will hear a reminder tone when you open the driver’s door.

**High Beams** — To turn on, push the lever forward until you hear a click. The blue high beam indicator will light (see page 58 ). Pull it back to return to low beams. To flash the high beams, pull the lever back lightly, then release it. The high beams will stay on as long as you hold the lever back.

### Daytime Running Lights (Canadian Models)

With the headlight switch off, the high beam headlights come on with reduced brightness when you turn the ignition switch ON (II) and release the parking brake. They remain on until you turn the ignition off, even if you set the parking brake.

The headlights revert to normal operation when you turn them on with the switch.

# Instrument Panel Brightness

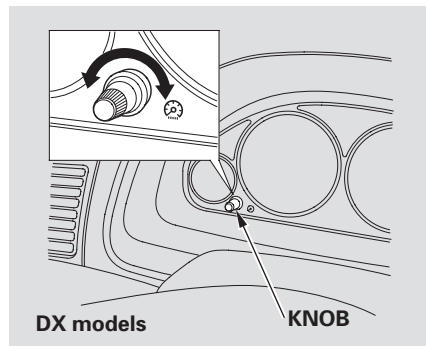

The knob on the instrument panel controls the brightness of the instrument panel lights. Turn the knob to adjust the brightness.

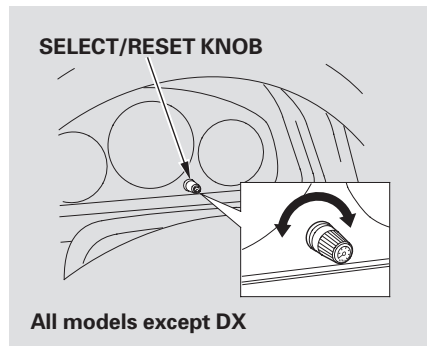

*On all models except DX*  
There are six brightness levels. When you turn the knob, the odometer/trip meter display changes to circles that show you the current level. You will hear a tone when you reach the maximum or minimum brightness.

Adjust the brightness to the desired level with the headlight switch off, and also with the headlight switch on.

To reduce glare at night, the instrument panel illumination dims when you turn the light switch to  $\text{☰}$  or  $\text{☷}$ . Turning the Select/Reset knob fully to the right will return the instrument panel to the brightness adjusted with the headlight switch off and a tone will sound.

## Hazard Warning Button

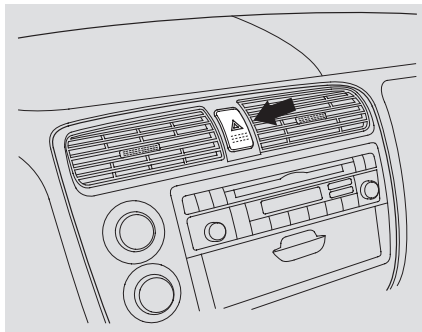

Push the button between the center vents to turn on the hazard warning lights (four-way flashers). This causes all four outside turn signals and both indicators in the instrument panel to flash. Use the hazard warning lights if you need to park in a dangerous area near heavy traffic, or if your vehicle is disabled.

## Rear Window Defogger

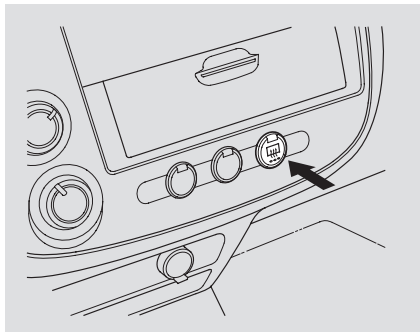

The rear window defogger will clear fog, frost, and thin ice from the window. Push the defogger button to turn it on and off. The light in the button lights to show the defogger is on. If you do not turn it off, the defogger will shut itself off after about 15 minutes. It also shuts off when you turn off the ignition. You have to turn it on again when you restart the vehicle.

Make sure the rear window is clear and you have good visibility before starting to drive.

The defogger and antenna wires on the inside of the rear window can be accidentally damaged. When cleaning the glass, always wipe side to side.

# Steering Wheel Adjustment

See page 16 for important safety information about how to properly position the steering wheel.

Make any steering wheel adjustment before you start driving.

## **⚠ WARNING**

Adjusting the steering wheel position while driving may cause you to lose control of the vehicle and be seriously injured in a crash.

Adjust the steering wheel only when the vehicle is stopped.

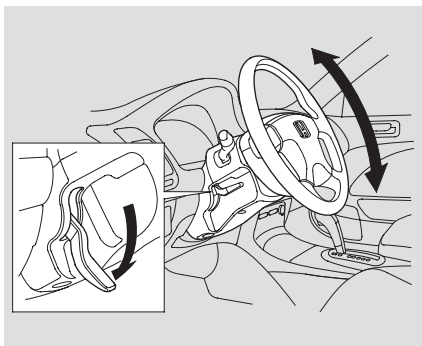

To adjust the steering wheel upward or downward:

1. Push the lever under the steering column all the way down.
2. Move the steering wheel so it points to your chest, not toward your face. Make sure you can see the instrument panel gauges and lights.

3. Push the lever up to lock the steering wheel in that position.

4. Make sure you have securely locked the steering wheel in place by trying to move it up and down.

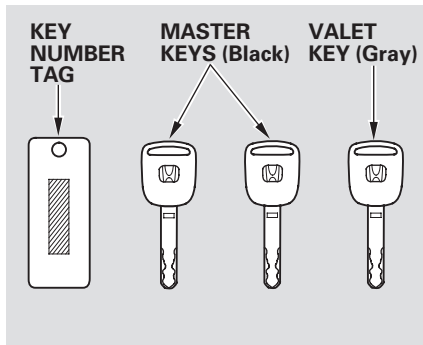

The master key fits all the locks on your vehicle. The valet key works only in the ignition and the door locks. You can keep the trunk, trunk release handle and rear seat trunk access locked when you leave your vehicle and the valet key at a parking facility.

You should have received a key number tag with your set of keys. You will need this key number if you ever have to get a key replaced. Use only Honda-approved key blanks.

These keys contain electronic circuits that are activated by the Immobilizer System. They will not work to start the engine if the circuits are damaged.

- Protect the keys from direct sunlight, high temperature, and high humidity.
- Do not drop the keys or set heavy objects on them.
- Keep the keys away from liquids. If they get wet, dry them immediately with a soft cloth.

The keys do not contain batteries. Do not try to take them apart.



# Immobilizer System

---

The Immobilizer System protects your vehicle from theft. If an improperly-coded key (or other device) is used, the engine's fuel system is disabled.

When you turn the ignition switch to ON (II), the Immobilizer System indicator should come on for a few seconds, then go out. If the indicator starts to blink, it means the system does not recognize the coding of the key. Turn the ignition switch to LOCK (0), remove the key, reinsert it, and turn the switch to ON (II) again.

The system may not recognize your key's coding if another immobilizer key or other metal object (i.e. key fob) is near the ignition switch when you insert the key.

If the system repeatedly does not recognize the coding of your key, contact your Honda dealer.

Do not attempt to alter this system or add other devices to it. Electrical problems could result that may make your vehicle undriveable.

If you have lost your key and cannot start your engine, contact a Honda dealer.

*As required by the FCC:*

*This device complies with Part 15 of the FCC rules. Operation is subject to the following two conditions: (1) This device may not cause harmful interference, and (2) this device must accept any interference received, including interference that may cause undesired operation.*

*Changes or modifications not expressly approved by the party responsible for compliance could void the user's authority to operate the equipment.*

*This device complies with Industry Canada Standard RSS-210.*

*Operation is subject to the following two conditions: (1) this device may not cause interference, and (2) this device must accept any interference that may cause undesired operation of the device.*

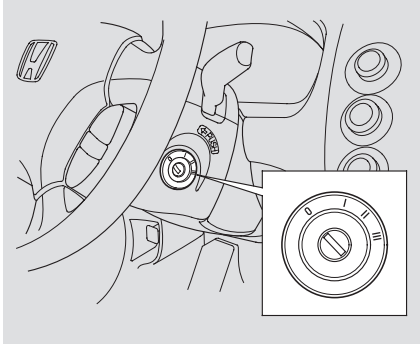

The ignition switch has four positions: **LOCK (0)**, **ACCESSORY (I)**, **ON (II)**, **START (III)**

**LOCK (0)** — You can insert or remove the key only in this position. To turn the key, you must push the key in slightly. If your vehicle has an automatic transmission, the shift lever must also be in park.

If the front wheels are turned, the anti-theft lock may make it difficult to turn the key. Firmly turn the steering wheel to the left or right as you turn the key.

**ACCESSORY (I)** — You can operate the audio system and the accessory power sockets in this position.

**ON (II)** — This is the normal key position when driving. Several of the lights on the instrument panel come on as a test when you turn the ignition switch from **ACCESSORY (I)** to **ON (II)**.

**START (III)** — Use this position only to start the engine. The switch returns to **ON (II)** when you let go of the key.

You will hear a reminder beeper if you leave the key in the ignition switch in the **LOCK (0)** or **ACCESSORY (I)** position and open the driver's door. Remove the key to turn off the beeper. The shift lever must be in Park before you can remove the key from the ignition switch.

## **⚠ WARNING**

Removing the key from the ignition switch while driving locks the steering. This can cause you to lose control.

Remove the key from the ignition switch only when parked.

# Door Locks

## Door Locks

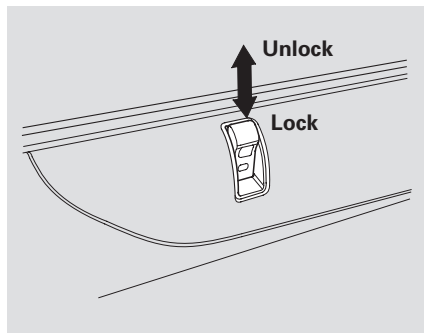

Each door has a lock tab on the top. Push the tab down to lock the door and pull it up to unlock.

To lock the passenger's door when getting out of the vehicle, push the lock tab down and close the door. To lock the driver's door, pull and hold the outside door handle then push the lock tab down. Release the handle, then close the door.

## Power Door Locks

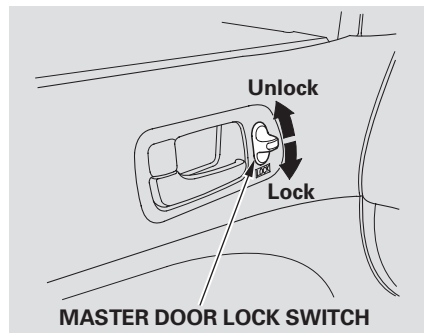

*Standard on HX, LX and EX models in the U.S., and DX SE, LX and Si models in Canada*

All doors lock when you push down the lock tab on the driver's door, or lock the driver's door from the outside with the key. Only the driver's door unlocks when you use the key or lock tab. To unlock the passengers' doors, use the master door lock switch or the lock tab on each door.

## Trunk

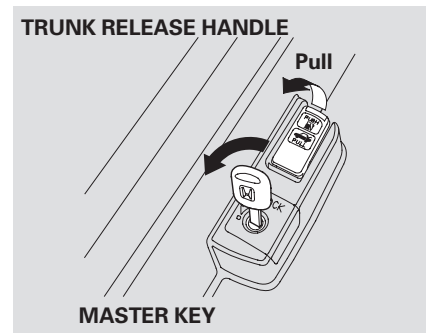

To open the trunk, pull the trunk release handle to the left of the driver's seat. To protect items in the trunk when you need to give the key to someone else, lock the trunk release handle with the master key and give the other person the valet key.

To close the trunk, press down on the trunk lid.

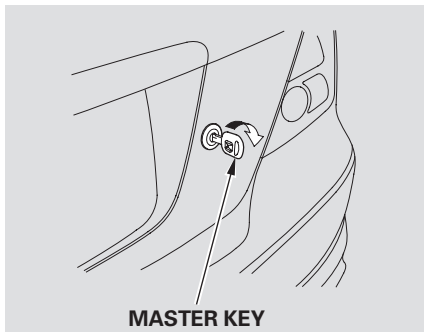

You can also use the master key to open the trunk lock.

Keep the trunk lid closed at all times while driving to avoid damaging it and to prevent exhaust gas from getting into the interior. See Carbon Monoxide Hazard, page 47.

## Emergency Trunk Opener

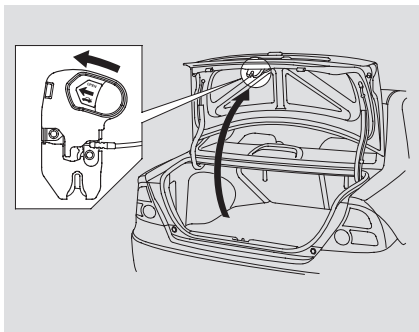

As a safety feature, your vehicle has a release lever on the trunk latch so the trunk can be opened from the inside.

To open the trunk, push the release lever to the left.

Parents should decide if their children should be shown how to use this feature.

# Remote Transmitter

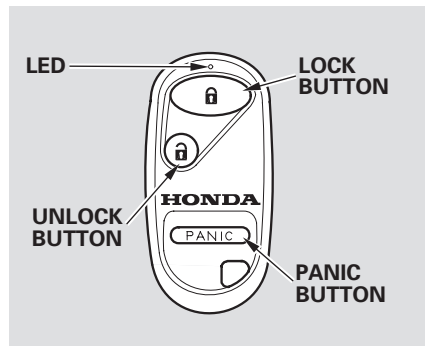

*Standard on LX and EX models in the U.S., and LX and Si models in Canada*

**LOCK** — Press this button once to lock all doors. Some exterior lights will flash. When you push LOCK twice within 5 seconds, you will hear a beep to verify that the doors are locked. You cannot lock it if any door is not fully closed or the key is in the ignition switch.

**UNLOCK** — Press this button once to unlock the driver's door. Push it twice to unlock the other doors. If you do not open any doors within 30 seconds, they will automatically relock.

**PANIC** — Press this button for about one second to attract attention; the horn will sound and the exterior lights will flash for about 30 seconds. To cancel panic mode, press any other button on the remote transmitter or turn the ignition switch to ON (II).

## *Remote Transmitter Care*

- Avoid dropping or throwing the transmitter.
- Protect the transmitter from extreme temperature.
- Do not immerse the transmitter in any liquid.
- If you lose a transmitter, the replacement needs to be reprogrammed by a Honda dealer.

## Replacing the Transmitter Battery

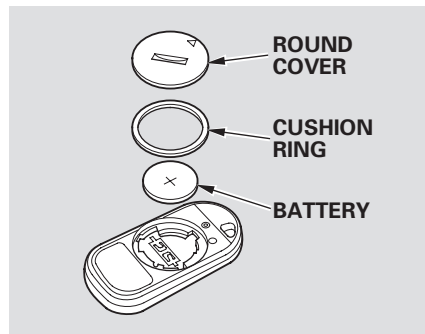

If it takes several pushes on the button to lock or unlock the doors, replace the battery as soon as possible.

Battery type: CR2025

To replace the battery, move the round cover on the back of the transmitter by turning it counterclockwise with a coin. Insert a new battery with the + side facing up. Align the ▽ mark on the cover with the ⊙ mark on the transmitter. Set the cover in place and turn it clockwise.

*As required by the FCC:*

*This device complies with Part 15 of the FCC rules. Operation is subject to the following two conditions: (1) This device may not cause harmful interference, and (2) this device must accept any interference received, including interference that may cause undesired operation.*

*Changes or modifications not expressly approved by the party responsible for compliance could void the user's authority to operate the equipment.*

*This device complies with Industry Canada Standard RSS-210.*

*Operation is subject to the following two conditions: (1) this device may not cause interference, and (2) this device must accept any interference that may cause undesired operation of the device.*

# Seats

## Front Seat Adjustments

See pages 11 – 13 for important safety information and warnings about how to properly position the seats and seat-backs.

Make all seat adjustments before you start driving.

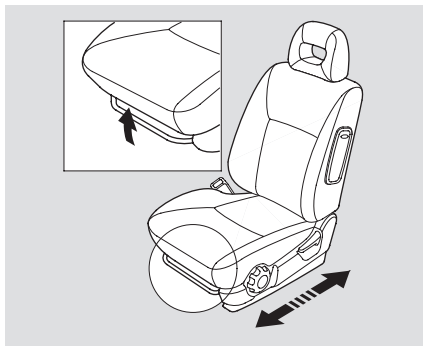

To adjust the seat forward and backward, pull up on the bar under the seat cushion's front edge. Then try to move the seat to make sure it is locked in position.

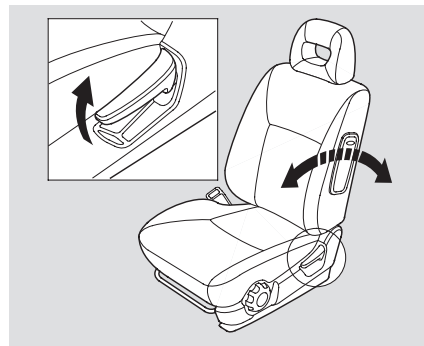

To change the seat-back angle, pull up on the lever on the outside of the seat bottom.

### Driver's Seat Height Adjustment

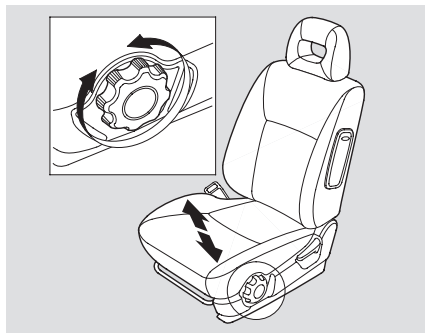

*On LX and EX models in the U.S., and LX and Si models in Canada*  
To adjust the height of the driver's seat, turn the dial on the outside of the seat bottom.

### Rear Seat Access

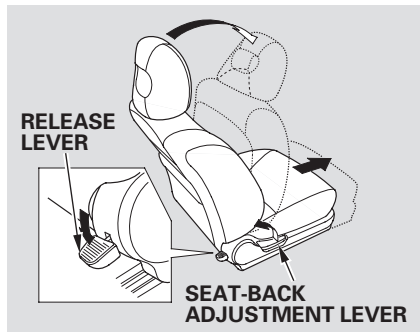

To get into the rear seat on the driver's side, pull up on the seat-back adjustment lever.

To get into the rear seat from the passenger's side in the U.S. DX model, pull up the seat-back adjustment lever. The seat-back will tilt forward. If more room is needed, use the seat adjustment bar to move the seat forward.

On all other models, push down the release lever at the base of the seat-back. The seat-back will tilt forward and the whole seat will slide forward.

*CONTINUED*



# Seats

*On HX model in the U.S., and all Canadian models*

When you return the seat-back upright, the seat stays in the fully forward position. Use the seat adjustment bar and the seat-back adjustment lever to move the seat to the desired position. Make sure the seat is fully latched before sitting in it.

*On LX and EX models in the U.S.*

As you return the seat-back upright, push the whole seat backward until it latches. Make sure the seat is fully latched before sitting in it.

## Head Restraints

*See page 14 for important safety information and a warning about how to properly position the head restraints.*

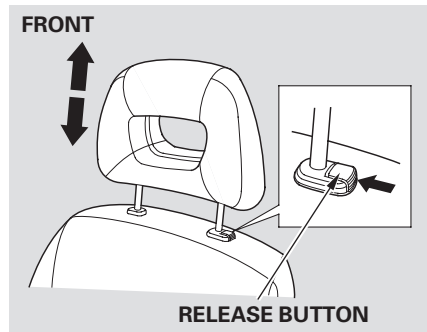

Your vehicle is equipped with head restraints in the front seats and the outboard seating positions in the rear.

The head restraints help protect you and your passengers from whiplash and other injuries. They are most effective when you adjust them so the back of the occupant's head rests against the center of the restraint.

The head restraints in the front and rear outboard seating positions adjust for height. You need both hands to adjust the restraint. To raise it, pull upward. To lower the restraint, push the release button sideways and push the restraint down.

## Armrest

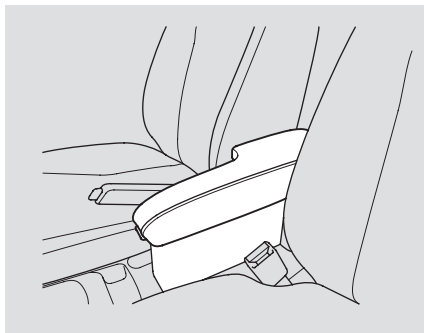

*On LX and EX models in the U.S., and Si models in Canada*  
The lid of the console compartment can be used as an armrest.

Make sure the passenger's hands or fingers are away from the armrest before pushing it down.

## Folding Rear Seat

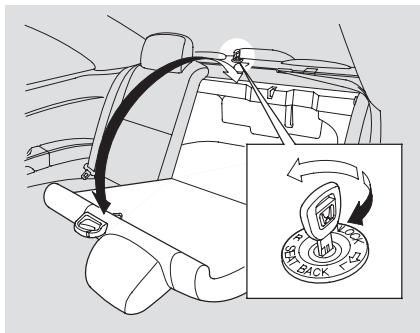

The left and right halves can be folded separately from inside the vehicle or inside the trunk. To fold down the seat-back from inside the vehicle, insert the master key in the lock on the rear shelf. To fold down the driver's side, turn the key clockwise, pull down the top of the seat-back, then release the key. To fold down the passenger's side, turn the key counterclockwise and perform the same procedure.

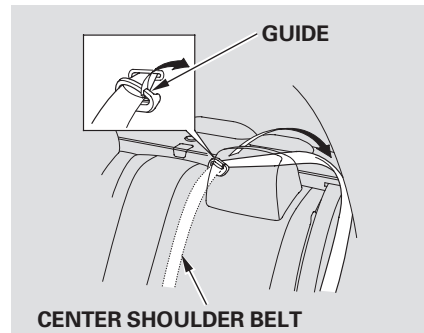

When storing cargo, you can move the rear center shoulder belt out of the way by removing the belt from the guide.

*CONTINUED*

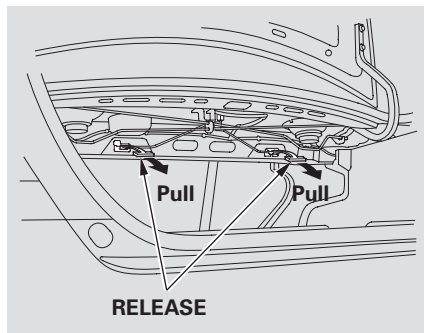

To release the seat-back from inside the trunk, pull the release under the trunk panel. Push the seat-back down, then let go of the release.

To lock the seat-back upright, push it firmly against the trunk panel. Make sure it is latched in place by pulling on the top of the seat.

Make sure all rear shoulder belts are positioned in front of the rear seat-back whenever it is in the upright position.

Do not put any heavy items on the seat-back when it is folded.

Make sure all items in the trunk, or items extending through the opening into the back seat, are secured. Loose items can fly forward and cause injury if you have to brake hard. See **Carrying Cargo** on page [122](#).

Never drive with the seat-back folded down and the trunk lid open. See **Carbon Monoxide Hazard** on page [47](#).

*On LX and EX models in the U.S., and LX and Si models in Canada*

Your vehicle's windows are electrically-powered. Turn the ignition switch to ON (II) to raise or lower any window.

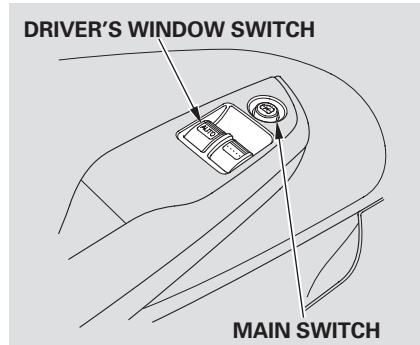

The driver's door armrest has a master power window control panel. To open the passenger's window, push down on the appropriate switch and hold it until the window reaches the desired position. To close the window, pull back on the window switch. Release the switch when the window gets to the position you want.

## **⚠ WARNING**

Closing a power window on someone's hands or fingers can cause serious injury.

Make sure your passenger is away from the window before closing it.

*CONTINUED*

## Power Windows, Moonroof

**AUTO** – To open the driver's window fully, push the window switch firmly down and release it. The window automatically goes all the way down. To stop the window from going all the way down, pull back on the window switch briefly.

If the MAIN switch is OFF, the passenger windows cannot be raised or lowered. Keep the MAIN switch off when you have children in the vehicle so they do not injure themselves by operating the windows unintentionally.

### Moonroof

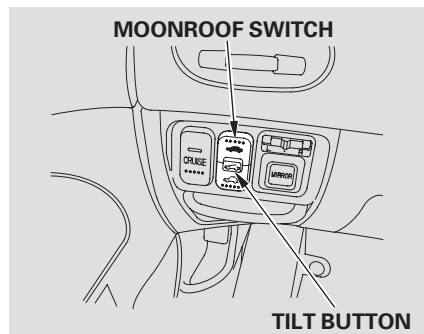

*On U.S. EX model, and Canada Si model*  
The moonroof can be tilted up in the back for ventilation, or it can be slid back into the roof. Use the switch under the left dashboard vent to operate the moonroof.

To tilt up the back of the moonroof, press and hold the center button (☁️). To close the moonroof, press and hold the top of the switch (🚗). To open the moonroof,

press and hold the bottom of the switch (🚗).

### WARNING

Opening or closing the moonroof on someone's hands or fingers can cause serious injury.

Make sure all hands and fingers are clear of the moonroof before opening or closing it.

### NOTICE

*If you try to open the moonroof in below-freezing temperatures, or when it is covered with snow or ice, you can damage the moonroof panel or motor.*

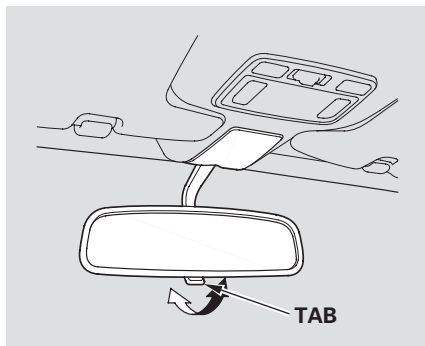

Keep the inside and outside mirrors clean and adjusted for best visibility. Be sure to adjust the mirrors before you start driving.

The inside mirror has day and night positions. The night position reduces glare from headlights behind you. Flip the tab on the bottom edge of the mirror to select the day or night position.

## Adjusting the Power Mirrors

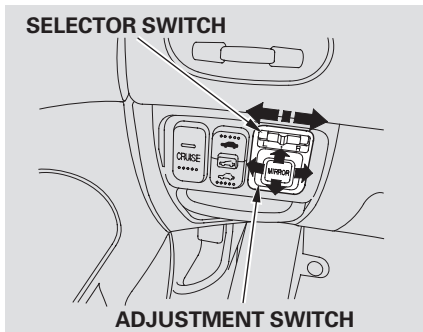

*On HX, LX and EX models in the U.S., and LX and Si models in Canada*

1. Move the selector switch to L (driver's side) or R (passenger's side).

2. Push the appropriate edge of the adjustment switch to move the mirror right, left, up, or down.
3. When you finish, move the selector switch to the center (off) position. This turns off the adjustment switch so you can't move a mirror out of position by accidentally bumping the switch.

# Mirrors, Parking Brake

## Power Mirror Heaters

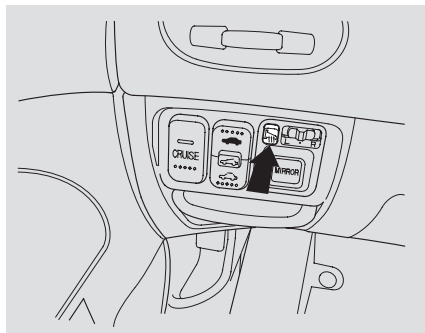

### *On Canadian Si model*

The outside mirrors are heated to remove fog and frost. With the ignition switch in the ON (II) position, turn on the heaters by pressing the button. The indicator in the button comes on as a reminder. Press the button again to turn the heaters off.

## Parking Brake

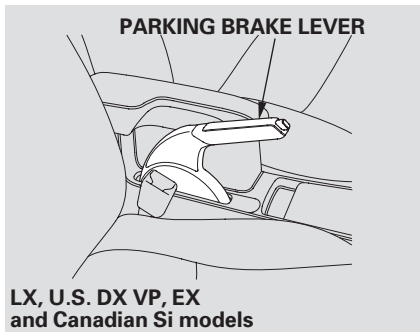

LX, U.S. DX VP, EX  
and Canadian Si models

To apply the parking brake, pull the lever up fully. To release it, pull up slightly, push the button, and lower the lever. The parking brake light on the instrument panel should go out when the parking brake is fully released (see page 57).



PARKING BRAKE LEVER  
DX, U.S. HX and Canada DX SE models

**NOTICE:** Driving the vehicle with the parking brake applied can damage the rear brakes and axles.

## Ceiling Light

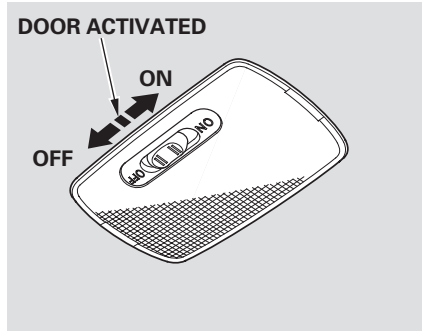

The ceiling light has a three-position switch; ON, Door Activated, and OFF.

In the Door Activated (center) position, the light comes on when you:

- Open any door.
- Remove the key from the ignition.  
If you do not open a door, the light fades out in about 10 seconds.
- Unlock the doors with the key or remote transmitter.

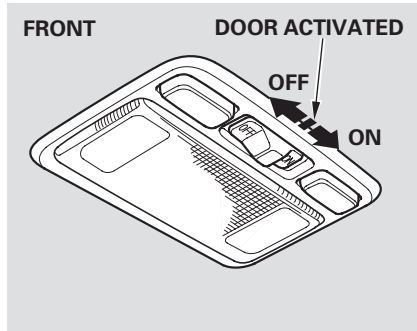

*On U.S. EX and Canada Si models*

The front ceiling light also contains two spotlights. Push the button next to the light to turn it on and off.

*On LX models*

Push on the spotlight lenses to turn the light on and off.

## Individual Interior Lights

The courtesy lights in the front doors and around the ignition switch come on when you open any door. After you close the door, the ignition switch light stays on for several seconds.



# Interior Convenience Items

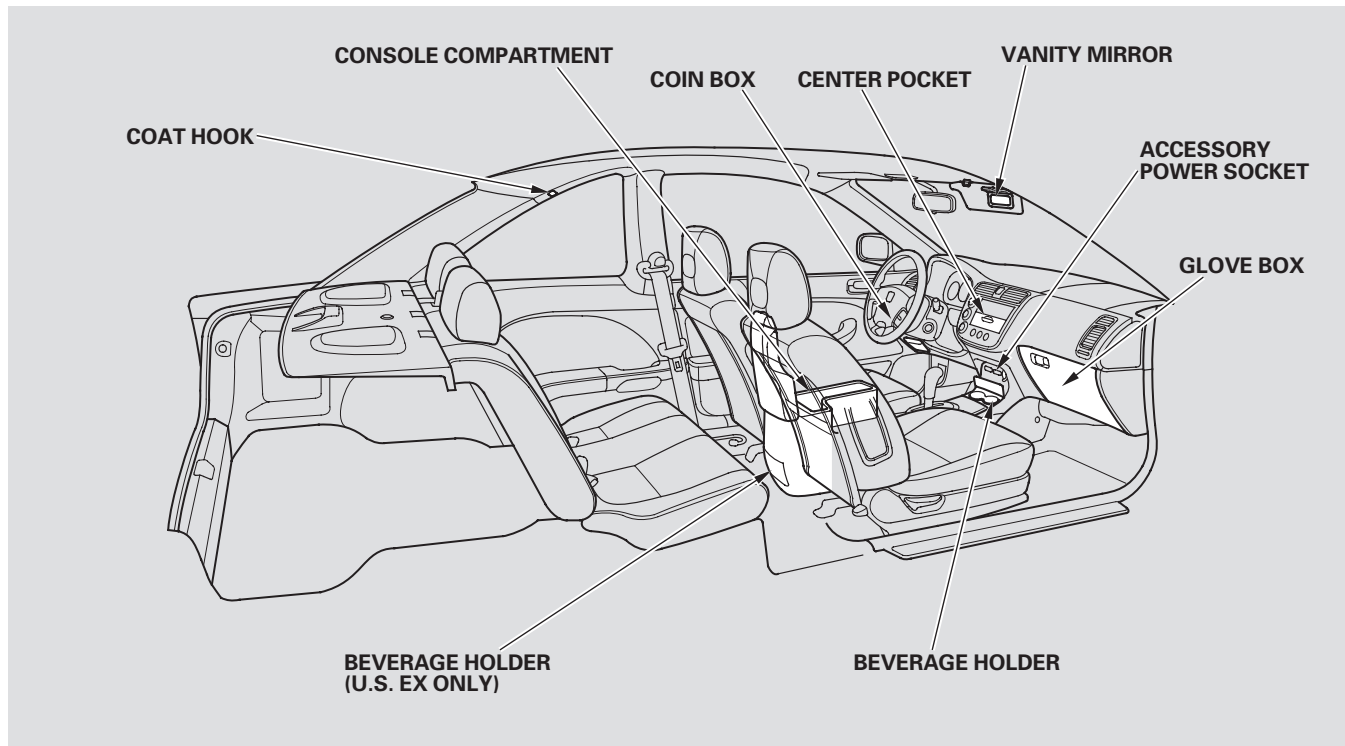

## Beverage Holders

Be careful when you are using the beverage holders. A spilled liquid that is very hot can scald you or your passengers. Spilled liquids can also damage the upholstery, carpeting, and electrical components in the interior.

On the U.S., LX, EX models and Canada LX and Si models, open the front beverage holder by pushing on the top.

On the U.S., EX model, open the rear beverage holder by pushing on the back and pulling the holder all the way out.

## Glove Box

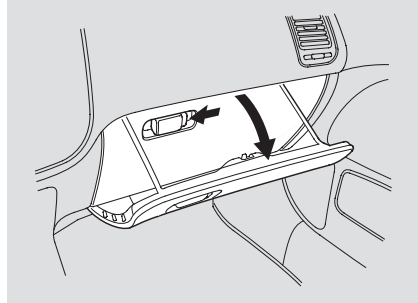

Open the glove box by squeezing the handle. Close it with a firm push.

### **⚠ WARNING**

An open glove box can cause serious injury to your passenger in a crash, even if the passenger is wearing the seat belt.

Always keep the glove box closed while driving.

## Console Compartment

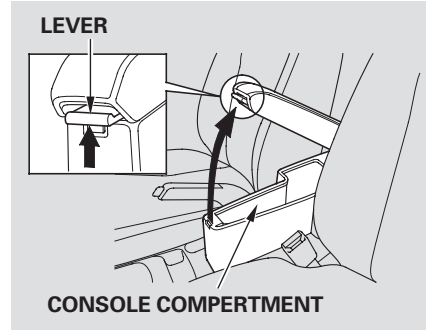

*On the U.S. LX, EX models and Canada LX and Si models*

To open the console compartment, pull the left lever and lift the lid.

To close, lower the lid and push it down until it latches.

# Interior Convenience Items

## Center Pocket

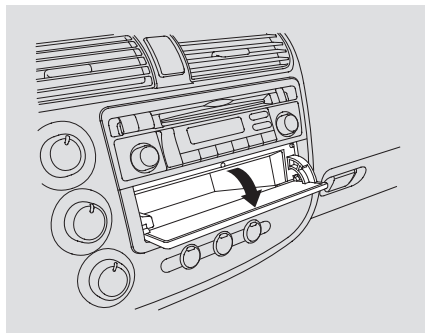

*On LX and EX models in the U.S., and LX and Si models in Canada*  
The center pocket is located under the audio system. To open the lid, pull it down. Close it with a firm push.

## Accessory Power Socket

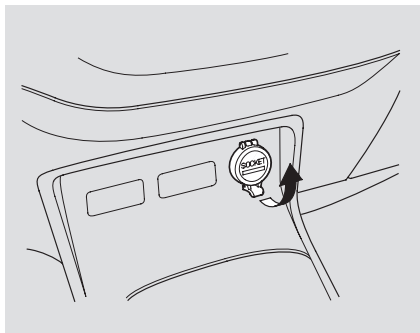

To use an accessory power socket, pull up the cover.

This socket is intended to supply power for 12 volt DC accessories that are rated 120 watts or less (10 amps). The ignition switch must be in ACCESSORY (I) or ON (II).

It will not power an automotive type cigarette lighter element.

## Vanity Mirror

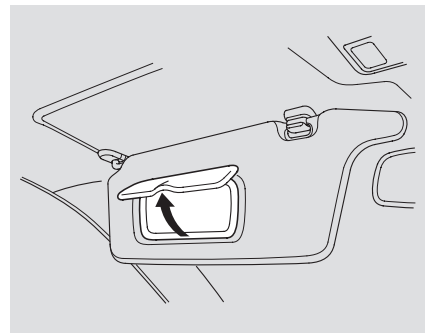

To use a vanity mirror on the back of the sun visor, pull up the cover.

The heating and air conditioning\* systems in your Honda provide a comfortable driving environment in all weather conditions.

The standard audio system has many features. This section describes those features and how to use them. (If you selected an optional audio system, refer to the operating instructions that came with it.)

*Standard for HX, LX and EX models in the U.S., and LX and Si models in Canada*

Your Honda has an anti-theft audio system that requires a code number to enable it.

\* Air conditioning is standard on LX and EX models in the U.S., and LX and Si models in Canada. It is optional on other models.

Vents, Heating, and A/C .....	90
Air Flow Buttons.....	91
Playing the Radio.....	94
Radio Reception.....	97
Playing a CD.....	99
CD Changer.....	100
Protecting Your CDs.....	101
CD Player Error Messages .....	102
CD Changer Error Messages.....	103
Playing a Tape.....	104
Radio Theft Protection.....	107
Setting the Clock .....	108
Cruise Control.....	110

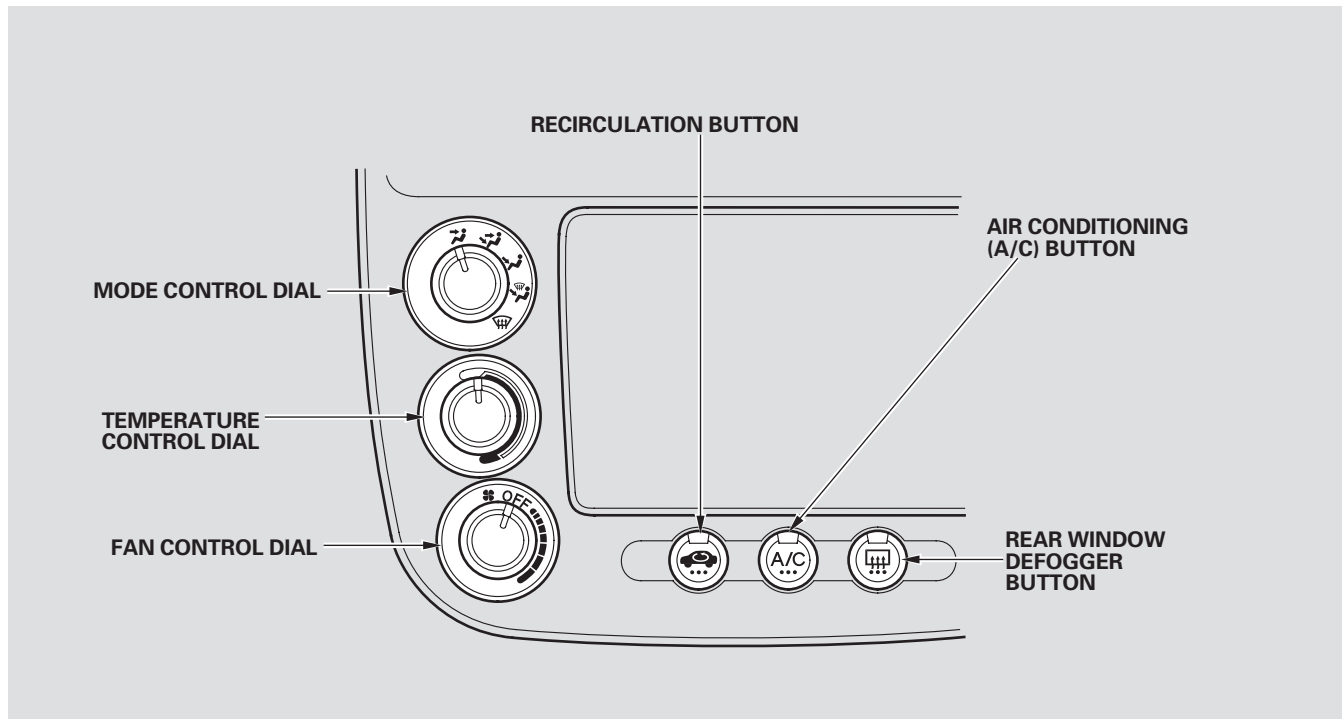

## Fan Control Dial

Turn this dial clockwise to increase fan speed and increase the airflow.

## Temperature Control Dial

Turning this dial clockwise increases the temperature of the airflow.

## Air Conditioning (A/C) Button

*Standard on LX and EX models in the U.S., and LX and Si models in Canada*  
*Optional on other models*

This button turns the air conditioning on and off. The light in the button is on when the A/C is on.

## Recirculation Button

When the light in the button is on, air from the vehicle's interior is sent throughout the system again. When the light is off, air is brought in from the outside of the vehicle (Fresh Air mode).

The outside air intakes for the heating and cooling system are at the base of the windshield. Keep this area clear of leaves and other debris.

The system should be left in Fresh Air mode under almost all conditions. Keeping the system in Recirculation mode, particularly with the A/C off, can cause the windows to fog up.

Switch to Recirculation mode when driving through dusty or smoky conditions, then return to Fresh Air mode.

## Rear Window Defogger Button



This button turns the rear window defogger off and on (see page 67).

## Mode Control Dial

Use the mode control dial to select the vents the air flow from. Some air will flow from the dashboard vents in all modes.

 Air flows from the center and corner vents in the dashboard.

 Air flow is divided between the vents in the dashboard and the floor vents.

 Air flows from the floor vents. When you select , the system automatically switches to Fresh Air mode.

 Air flow is divided between the floor vents and the defroster vents at the base of the windshield.

 Air flows from the defroster vents at the base of the windshield.

When you select  or , the system automatically switches to Fresh Air mode and turns on the A/C.

## Ventilation

The flow-through ventilation system draws in outside air, circulates it through the interior, then exhausts it through vents near the rear side panels.

1. Turn the temperature control dial all the way to the left.
2. Make sure the A/C is off.
3. Select  and Fresh Air mode.
4. Set the fan to the desired speed.

## Using the Heater

The heater uses engine coolant to warm the air. If the engine is cold, it will be several minutes before you feel warm air coming from the system.

1. Select  and Fresh Air mode.
2. Set the fan to the desired speed.
3. Adjust the warmth of the air with the temperature control dial.

## Using the A/C

Air conditioning places an extra load on the engine. Watch the engine coolant temperature gauge (see page 61). If it moves near the red zone, turn off the A/C until the gauge reads normally.

1. Turn on the A/C by pressing the button. The light in the button comes on when a fan speed is selected.
2. Make sure the temperature control dial is all the way to the left.
3. Select .
4. If the outside air is humid, select Recirculation mode. If the outside air is dry, select Fresh Air mode.
5. Set the fan to the desired speed.

*If the interior is very warm, you can cool it down more rapidly by partially opening the windows, turning on the A/C, and setting the fan to maximum speed in Fresh Air mode.*

## Dehumidify the Interior



Air conditioning, as it cools, removes moisture from the air. When used in combination with the heater, it makes the interior warm and dry.

1. Switch the fan on.
2. Turn on the air conditioning.
3. Select  and Fresh Air mode.
4. Adjust the temperature control dial to your preference.

This setting is suitable for all driving conditions whenever the outside temperature is above 32°F (0°C).



## To Defog and Defrost

To remove fog from the inside of the windows:

1. Set the fan to the desired speed.
2. Select . When you select , the system automatically switches to Fresh Air mode and turns on the A/C. (The A/C indicator will not come on.)
3. Adjust the temperature control dial so the airflow feels warm.
4. Select  to help clear the rear window.

When you switch to another mode from , the A/C stays on. Press the A/C button to turn it off.

## To Remove Exterior Frost or Ice From the Windows

1. Select . The system automatically switches to Fresh Air mode and turns on the A/C. (The A/C indicator will not come on.)
2. Select .
3. Set the fan and temperature controls to maximum level.

To clear the windows faster, you can close the dashboard corner vents by rotating the wheel below it. This will send more warm air to the windshield defroster vents. Once the windshield is clear, select the Fresh Air mode to avoid fogging the windows.

For your safety, make sure you have a clear view through all the windows before driving.



# Playing the Radio

DX Model

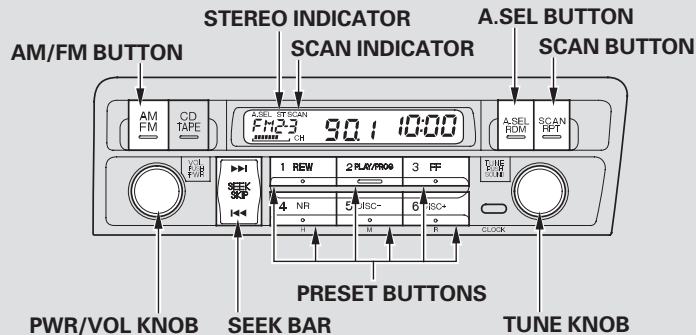

U.S.: HX, LX, EX Models  
Canada: LX, Si Models

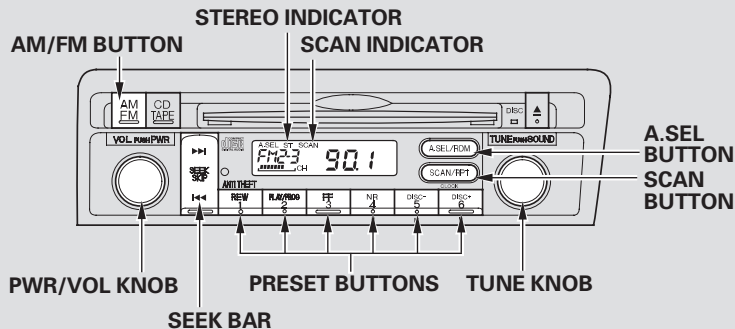

## To Play the Radio

The ignition switch must be in the ACCESSORY (I) or ON (II) position. Turn the system on by pushing the PWR/VOL knob or the AM/FM button. Adjust the volume by turning the same knob.

The band and frequency that the radio was last tuned to is displayed. To change bands, press the AM/FM button. On the FM band, ST will be displayed if the station is broadcasting in stereo. Stereo reproduction on AM is not available.

## To Select a Station

You can use any of five methods to find radio stations on the selected band: **TUNE**, **SEEK**, **SCAN**, the preset buttons, and **AUTO SELECT**.

**TUNE** — Use the TUNE knob to tune the radio to a desired frequency. Turn the knob right to tune to a higher frequency, or left to tune to a

lower frequency.

**SEEK** — The SEEK function searches up and down from the current frequency to find a station with a strong signal. To activate it, press the ◀◀ or ▶▶ side of the bar, then release it.

**SCAN** — The SCAN function samples all stations with strong signals on the selected band. To activate it, press the SCAN button, then release it. You will see SCAN in the display. The system will scan for a station with a strong signal. When it finds one, it will stop and play that station for about five seconds.

If you do nothing, the system will then scan for the next strong station and play it for five seconds. When it plays a station you want to listen to, press the SCAN button again.

**Preset** — Each preset button can store one frequency on AM, and two frequencies on FM.

1. Select the desired band, AM or FM. FM1 and FM2 let you store two frequencies with each preset button.
2. Use the TUNE, SEEK, or SCAN function to tune the radio to a desired station.
3. Pick a preset button, and hold it until you hear a beep.
4. Repeat steps 1 to 3 to store a total of six stations on AM and twelve stations on FM.

The preset frequencies will be lost if your vehicle's battery goes dead, is disconnected, or the radio fuse is removed.

# Playing the Radio

---

**AUTO SELECT** – If you are traveling far from home and can no longer receive your preset stations, you can use the Auto Select feature to find stations in the local area.

Press the A. SEL Button. “A.SEL” flashes in the display, and the system goes into scan mode for several seconds. It stores the frequencies of six AM, and twelve FM stations in the preset buttons.

You will see a “0” displayed after pressing a preset button if Auto Select cannot find a strong station for every preset button.

If you do not like the stations Auto Select has stored, you can store other frequencies on the preset buttons. Use the TUNE, SEEK, or SCAN functions to find stations, then store them in the preset buttons as described.

*To turn off Auto Select, press the A. SEL button. This restores the presets you originally set.*

## **Adjusting the Sound**

Press the SOUND (TUNE) knob repeatedly to display the Bass (BAS), Treble (TRE), Balance (BAL), and Fader (FAD) setting.

Each mode is shown in the display as it changes. Turn the SOUND (TUNE) knob to adjust the setting to your liking. When the level reaches the center, you will see “” in the display. The system will automatically return the display to the selected audio mode about five seconds after you stop adjusting a mode.

**Treble/Bass** – Use the TRE/BAS modes to adjust the tone to your liking.

**Balance/Fader** – These two modes adjust the strength of the sound coming from each speaker. BAL adjusts the side-to-side strength, while FAD adjusts the front-to-back strength.

## **Audio System Lighting**

You can use the instrument panel brightness control knob to adjust the illumination of the audio system (see page 66). The audio system illuminates when the parking lights are on, even if the radio is off.

## Radio Frequencies

Your Honda's radio can receive the complete AM and FM bands. Those bands cover these frequencies:

AM band:

530 to 1,710 kilohertz

FM band:

87.7 to 107.9 megahertz

Radio stations on the AM band are assigned frequencies at least ten kilohertz apart (530, 540, 550).

Stations on the FM band are assigned frequencies at least 0.2 megahertz apart (87.9, 88.1, 88.3).

Stations must use these exact frequencies. It is fairly common for stations to round-off the frequency in their advertising, so your radio could display a frequency of 100.9 even though the announcer may identify the station as "FM101."

## Radio Reception

How well your Honda's radio receives stations is dependent on many factors, such as the distance from the station's transmitter, nearby large objects, and atmospheric conditions.

A radio station's signal gets weaker as you get farther away from its transmitter. If you are listening to an AM station, you will notice the sound volume becoming weaker, and the station drifting in and out. If you are listening to an FM station, you will see the stereo indicator flickering off and on as the signal weakens. Eventually, the stereo indicator will go off and the sound will fade completely as you get out of range of the station's signal.

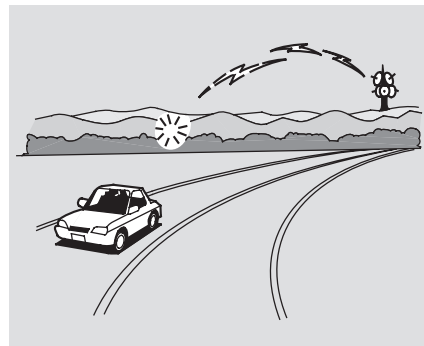

Driving very near the transmitter of a station that is broadcasting on a frequency close to the frequency of the station you are listening to can also affect your radio's reception. You may temporarily hear both stations, or hear only the station you are close to.

*CONTINUED*

# Radio Reception

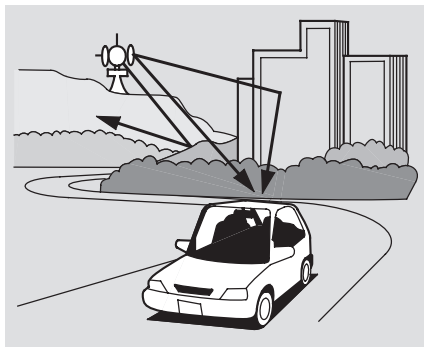

Radio signals, especially on the FM band, are deflected by large objects such as buildings and hills. Your radio then receives both the direct signal from the station's transmitter, and the deflected signal. This causes the sound to distort or flutter. This is a main cause of poor radio reception in city driving.



Radio reception can be affected by atmospheric conditions such as thunderstorms, high humidity, and even sunspots. You may be able to receive a distant radio station one day and not receive it the next day because of a change in conditions.

Electrical interference from passing vehicles and stationary sources can cause temporary reception problems.

*As required by the FCC:  
Changes or modifications not expressly  
approved by the party responsible for  
compliance could void the user's  
authority to operate the equipment.*

## DX Model

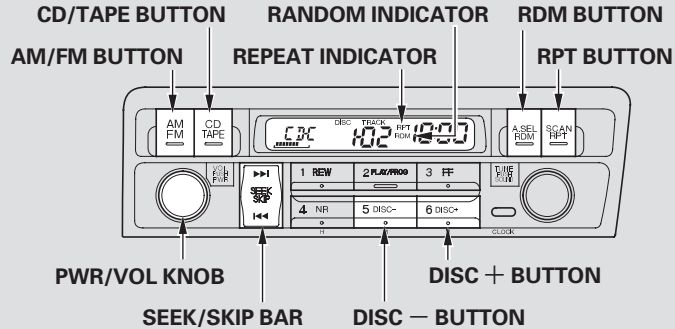

## U.S.: HX, LX, EX Models Canada: LX, Si Models

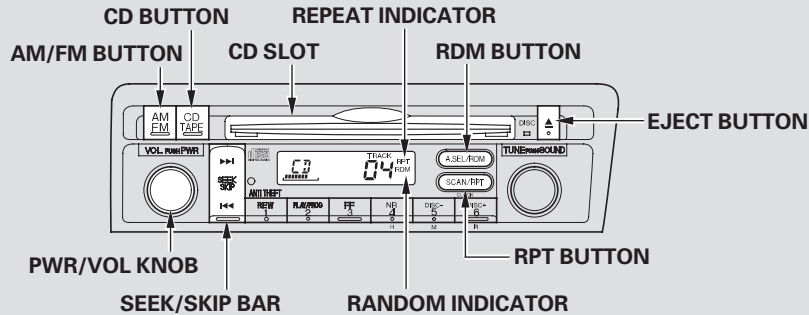

# Playing a CD, CD Changer

---

## CD Player

*Optional on DX model*

With the ignition in the ACCESSORY (I) or ON (II) position, insert a CD into the CD slot. The drive will pull the CD in the rest of the way and begin to play it. You operate the CD player with the same controls used for the radio. The number of the track playing is shown in the display. The system will continuously play a CD until you change modes.

## To Change Tracks (SKIP)

Each time you press and release **▶▶|**, the player skips forward to the beginning of the next track. Press and release **|◀◀** to skip backward to the beginning of the previous track.

To move rapidly within a track, press and hold the **▶▶|** or **|◀◀**. You will see CUE or REW in the display.

**REPEAT** — To continuously replay

a track, press and release the RPT button. You will see RPT in the display. Press the RPT button again to turn it off.

**RANDOM** — This feature plays the tracks in random order. To activate Random Play, press and release the RDM button. You will see RDM in the display. This continues until you press the RDM button again.

## To Stop Playing a CD

Press the eject button ( **▲** ) to remove the CD. If you eject the CD, but do not remove it from the slot, the system will automatically reload the CD after 15 seconds and put it in pause mode. To begin playing, press the CD button. Press the AM/FM button to switch to the radio while a CD is playing. Press the CD button to play the CD. If you turn the system off while a CD is playing, either with the PWR/VOL knob or by turning off the ignition,

the CD will stay in the drive. When you turn the system back on, the CD will begin playing where it left off.

## Operating the Optional CD Changer

A CD changer is available for your vehicle. It holds up to six CDs. You operate the CD changer with the same controls used for the in-dash CD player.

Load the desired CDs in the magazine, and load the magazine in the changer according to the instructions that came with the unit.

To select the CD changer, press the CD button. The CD and track numbers will be displayed. To select a different CD, use the preset 5 (DISC -) or preset 6 (DISC +) button. If you select an empty slot in the magazine, the changer will, after finding that slot empty, try to load the CD in the next slot.

## General Information

- When using CD-R discs, use only high quality CDs labeled for audio use.
- When recording a CD-R, the recording must be closed for it to be used by the CD players.
- CD-RW discs will not work in this unit.
- Play only standard round CDs. Odd-shaped CDs may jam in the drive or cause other problems.
- Handle your CDs properly to prevent damage and skipping.

## Protecting CDs

When a CD is not being played, store it in its case to protect it from dust and other contamination. To prevent warpage, keep CDs out of direct sunlight and extreme heat.

To clean a CD, use a clean soft cloth. Wipe across the CD from the center to the outside edge.

A new CD may be rough on the inner and outer edges. The small plastic pieces causing this roughness can flake off and fall on the recording surface of the CD, causing skipping or other problems. Remove these pieces by rubbing the inner and outer edges with the side of a pencil or pen.

Never try to insert foreign objects in the CD player or the magazine.

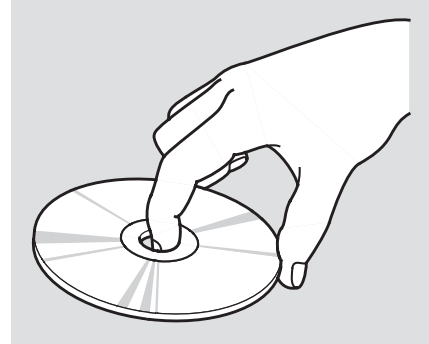

Handle a CD by its edges; never touch either surface. Do not place stabilizer rings or labels on the CD. These, along with contamination from fingerprints, liquids, and felt-tip pens, can cause the CD to not play properly, or possibly jam in the drive.



## CD Player Error Messages

---

If you see an error message in the display while playing a CD, find the cause in the chart to the right. If you cannot clear the error indication, take your vehicle to a Honda dealer.

Error Message	Cause	Solution
CD DISC	FOCUS Error	Press the EJECT button and pull out the CD. Check if it is inserted correctly in the CD player. Make sure the CD is not scratched or damaged.
CD ERR	Mechanical Error	Press the EJECT button and pull out the CD. Check the CD for damage or deformation. If the CD cannot be pulled out, or the error message does not disappear after the CD is ejected, see a Honda dealer.
CD Hot	High temperature.	Will disappear when the temperature returns to normal.

If you see an error message in the display while playing a CD, find the cause in the chart to the right. If you cannot clear the error indication, take your vehicle to a Honda dealer.

Error Message	Cause	Solution
CD DISC	FOCUS Error	Press the magazine eject button and pull it out. If the message does not disappear or the magazine cannot be pulled out, see a Honda dealer.
	No CD in the CD magazine	Insert CD.
CD ERR	Mechanical Error	Press the magazine eject button and pull it out, check for an error indication, and insert the magazine again. If the message does not disappear or the magazine cannot be pulled out, see a Honda dealer.
CD HOT	High temperature.	Will disappear when the temperature returns to normal.
CD EJECT	No CD magazine in the CD changer.	Insert CD magazine.

# Playing a Tape (Optional)

DX Model

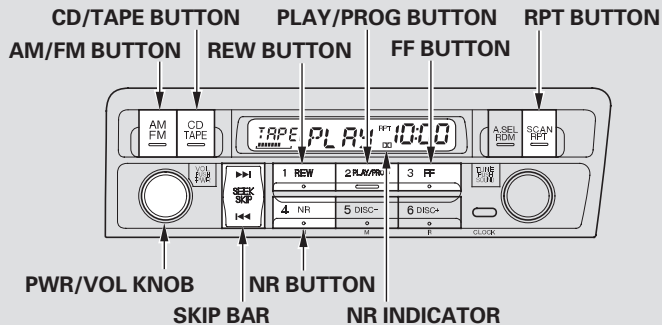

U.S.: HX, LX, EX Models  
Canada: LX, Si Models

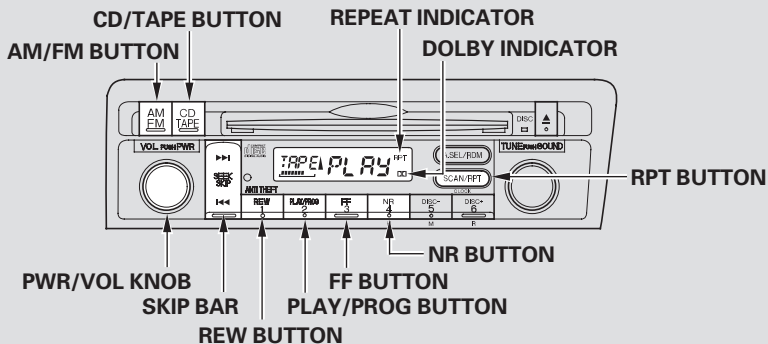

### To Play a Tape

*Tape player is optional*

The ignition switch must be in ACCESSORY (I) or ON (II). Make sure the open side of the tape is facing right, then insert the tape most of the way into the slot. The system will pull the tape in the rest of the way, and begin to play it.

The tape direction indicator will come on to show you which side of the tape is playing. The ▲ indicates the side you inserted upward in now playing. If you want to play the other side, press the PLAY/PROG button. When the player reaches the end of the tape, it will automatically reverse direction and play the other side.

Dolby\* noise reduction turns on when you insert a tape. The □□ indicator will light in the display. If the tape was not recorded in Dolby, turn it off by pressing the NR button. Dolby remains off until you press the NR button again.

\* Dolby noise reduction manufactured under license from Dolby Laboratories Licensing Corporation. "DOLBY" and the double-D symbol □□ are trademarks of Dolby Laboratories Licensing Corporation.

### To Stop Playing a Tape

To remove the tape, press the EJECT button. If you want to turn the player off, press the PWR/VOL knob or turn off the ignition. The tape will remain in the drive. When you turn the system back on, the tape will begin playing where it left off.

To switch to the radio or CD player while a tape is playing, press the AM/FM or CD/TAPE button. To change back to the tape player, press the CD/TAPE button.

### Tape Search Functions

**FF/REW** — To rewind the tape, push the REW button. You will see REW in the display. To fast forward the tape, push the FF button. You will see FF displayed. Press the FF, REW, or PLAY/PROG button to take the system out of rewind or fast forward.

**SKIP** — Press ◀◀ button to find the beginning of the current song or passage. Press ▶▶ button to find the beginning of the next song or passage. When the system reaches the beginning of a song or passage, it begins to play it.

*CONTINUED*

## Playing a Tape (Optional)

---

**REPEAT** — Press the RPT button to continuously play a song or passage. You will see RPT displayed. The track will repeat until you press the RPT button again.

**NOTE:** The SKIP and REPEAT functions use silent periods on the tape to find the end of a song or passage. These features may not work if there is almost no gap between selections, a high noise level, or a silent period in the middle of a selection.

### Caring for the Tape and Player

The tape player picks up dirt and oxides from the tape. This contamination builds up over time and cause the sound quality to degrade. To prevent this, you should clean the player after every 30 hours of use.

If you do not clean the tape player regularly, it may eventually become impossible to remove the contamination with a normal cleaning kit. Your Honda dealer has a cleaning kit available.

Use 100-minute or shorter tapes. Tapes longer than that may break or jam the drive.

If the tape is loose, tighten it by turning the hub with a pencil or your finger. If the label is peeling off, remove it or it could cause the cassette to jam in the player. Never try to insert a warped or damaged

cassette in the player.

Store tapes in their cases to protect them from dust and moisture. Never place tapes where they will be exposed to direct sunlight, high heat, or high humidity. If a tape is exposed to extreme heat or cold, let it reach a moderate temperature before inserting it into the player.

Never try to insert foreign object into the tape player.

*Standard for HX, LX and EX models in the U.S., and LX and Si models in Canada*

Your vehicle's audio system will disable itself if it is disconnected from electrical power for any reason. To make it work again, the user must enter a specific five-digit code in the Preset buttons. Because there are hundreds of number combinations possible from the five-digits, making the system work without knowing the exact code is nearly impossible.

You should have received a card that lists your audio system code number and serial number. It is best to store this card in a safe place at home. In addition, you should write the audio system's serial number in this Owner's Manual.

If you lose the card, you must obtain the code number from a Honda dealer. To do this, you will need the

system's serial number.

If your vehicle's battery is disconnected or goes dead, the audio system will disable itself. If this happens, you will see " EEE " in the frequency display the next time you turn on the system. Use the Preset buttons to enter the five-digit code. The code is located on the radio code card included in your Owner's Manual kit. When it is entered correctly, the radio will start playing.

If you make a mistake entering the code, do not start over; complete the five-digit sequence, then enter the correct code. You have ten tries to enter the correct code. If you are unsuccessful in ten attempts, you must then leave the system on for 1 hour before trying again.

You will have to store your favorite stations in the Preset buttons after the system begins working. Your original settings were lost when the power was disconnected.

# Setting the Clock

DX Model

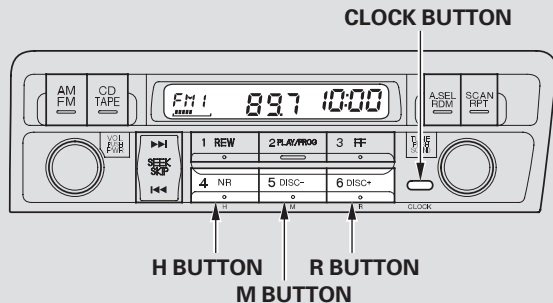

U.S.: HX, LX, EX Models  
Canada: LX, Si Models

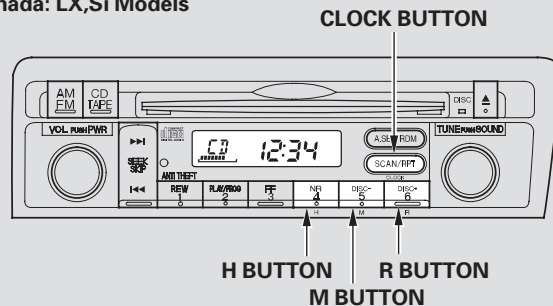

If your vehicle's battery is disconnected or goes dead, you will need to set the clock.

*Vehicles with CD Player/Changer*  
Press the CLOCK (SCAN/RPT) button until you hear a beep, then release the button. Change the hours by pressing the H (Preset 4) button until the numbers advance to the desired time. Change the minutes by pressing the M (Preset 5) button

until the numbers advance to the desired time.

When you are finished, press the CLOCK button again.

*Vehicles without CD Player/Changer*  
You can set the time only when the clock is displayed.

Adjust the hours by pressing and holding the CLOCK button, then

pressing the H (Preset 4) button.

Adjust the minutes by pressing and holding the CLOCK button, then pressing the M (Preset 5) button.

You can quickly set the time to the nearest hour.

*Vehicles with CD Player/Changer*

If the displayed time is before the half hour, press the CLOCK (SCAN/RPT) button until you hear a beep, then press the R (Preset 6) button to set the clock back to the previous hour. If the displayed time is after the half hour, the clock sets forward to the beginning of the next hour.

*Vehicles without CD Player/Changer*

If the displayed time is before the half hour, press and hold the CLOCK button, then press the R (Preset 6) button to set the clock back to the previous hour. If the displayed time is after the half hour, the clock sets forward to the beginning of the next hour.

For example: 1:06 will reset to 1:00  
1:52 will reset to 2:00



# Cruise Control

On HX, LX and EX models in the U.S., and LX and Si models in Canada Cruise control allows you to maintain a set speed above 25 mph (40 km/h) without keeping your foot on the accelerator pedal. It should be used for cruising on straight, open highways. It is not recommended for city driving, winding roads, slippery roads, heavy rain, or bad weather.

## **⚠ WARNING**

Improper use of the cruise control can lead to a crash.

Use the cruise control only when traveling on open highways in good weather.

## Using the Cruise Control

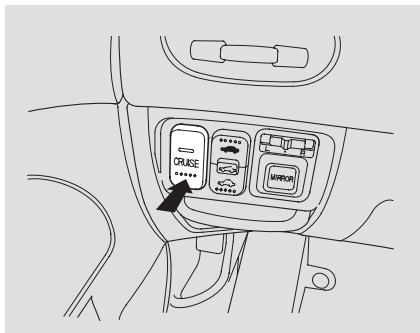

1. Push in the Cruise Control Master Switch. The indicator in the switch will light.
2. Accelerate to the desired cruising speed above 25 mph (40 km/h).

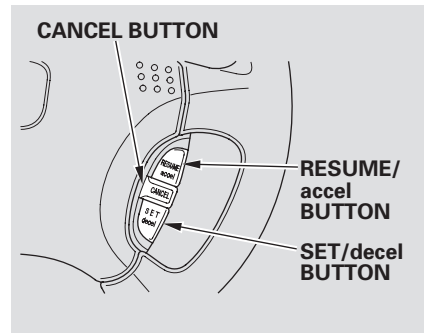

3. Press and release the SET/decel button on the steering wheel. The CRUISE CONTROL light on the instrument panel comes on to show the system is now activated.

The cruise control may not hold the set speed when you are going up and down hills. If your speed increases going down a hill, use the brakes to slow down. This will cancel the cruise control. To resume the set speed, press the RESUME/accel button. The CRUISE CONTROL light on the instrument panel will come back on.

## Changing the Set Speed

You can increase the set cruising speed in any of these ways:

- Press and hold the RESUME/accel button. When you reach the desired cruising speed, release the button.
- Push on the accelerator pedal. Accelerate to the desired cruising speed and press the SET/decel button.
- To increase your speed in very small amounts, tap the RESUME/accel button. Each time you do this, your vehicle will speed up about 1 mph (1.6 km/h).

You can decrease the set cruising speed in any of these ways:

- Press and hold the SET/decel button. Release the button when you reach the desired speed.
- To slow down in very small amounts, tap the SET/decel button. Each time you do this, your vehicle will slow down about 1 mph (1.6 km/h).
- Tap the brake or clutch pedal lightly with your foot. The CRUISE CONTROL indicator on the instrument panel will go out. When the vehicle slows to the desired speed, press the SET/decel button.

*CONTINUED*

# Cruise Control

---

Even with the cruise control turned on, you can still use the accelerator pedal to speed up for passing. After completing the pass, take your foot off the accelerator pedal. The vehicle will return to the set cruising speed.

Resting your foot on the brake or clutch pedal will cause the cruise control to cancel.

## **Cancelling the Cruise Control**

You can cancel the cruise control in any of these ways:

- Tap the brake or clutch pedal.
- Push the CANCEL button on the steering wheel.
- Press the Cruise Control Master Switch.

## **Resuming the Set Speed**

When you push the CANCEL button, or tap the brake or clutch pedal, the system remembers the previously-set cruising speed. To return to that speed, accelerate to above 25 mph (40 km/h) then press the RESUME/accel button. The CRUISE CONTROL light comes on, and the vehicle will accelerate to the same cruising speed as before.

Pressing the Cruise Control Master Switch turns the system completely off and erases the previous cruising speed.

Before you begin driving your Honda, you should know what gasoline to use, and how to check the levels of important fluids. You also need to know how to properly store luggage or packages. The information in this section will help you. If you plan to add any accessories to your vehicle, please read the information in this section first.

Break-in Period .....	114
Gasoline Type .....	114
Service Station Procedures .....	115
Fuel Economy .....	119
Accessories and Modifications ....	120
Carrying Cargo .....	122

# Break-in Period, Gasoline Type

---

## Break-in Period

Help assure your vehicle's future reliability and performance by paying extra attention to how you drive during the first 600 miles (1,000 km). During this period:

- Avoid full-throttle starts and rapid acceleration.
- Avoid hard braking for the first 200 miles (300 km).
- Do not change the oil until the scheduled maintenance time.

You should also follow these recommendations with an overhauled or exchanged engine, or when the brakes are replaced.

## Gasoline Type

Your Honda is designed to operate on unleaded gasoline with a pump octane number of 86 or higher. Use of a lower octane gasoline can cause a persistent, heavy, metallic rapping noise in the engine that can lead to mechanical failure.

We recommend using gasoline containing detergent additives that help prevent fuel system and engine deposits.

In addition, in order to maintain good performance, fuel economy, and emissions control, we strongly recommend, in areas where it is available, the use of gasoline that does NOT contain manganese-based fuel additives such as MMT.

Use of gasoline with these additives may adversely affect performance, and cause the Malfunction Indicator Lamp on your instrument panel to come on. If this happens, contact

your authorized Honda dealer for service.

Some gasoline today is blended with oxygenates such as ethanol or MTBE. Your vehicle is designed to operate on oxygenated gasoline containing up to 10 percent ethanol by volume and up to 15 percent MTBE by volume. Do not use gasoline containing methanol.

If you notice any undesirable symptoms, try another service station or switch to another brand of gasoline.

For further important fuel-related information, please refer to your Quick Start Guide.

## Fueling

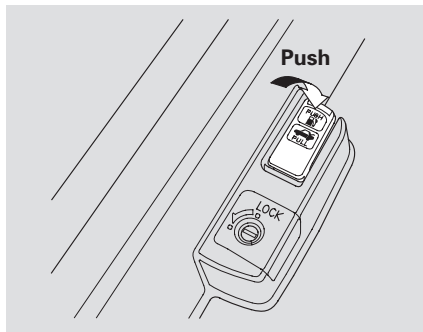

1. Park with the driver's side of the vehicle closest to the service station pump.
2. Open the fuel fill door by pulling on the handle to the left of the driver's seat.

**⚠ WARNING**

Gasoline is highly flammable and explosive. You can be burned or seriously injured when handling fuel.

- Stop the engine and keep heat, sparks, and flames away.
  - Handle fuel only outdoors.
  - Wipe up spills immediately.
3. Remove the fuel fill cap slowly. You may hear a hissing sound as pressure inside the tank escapes. Place the cap in the holder on the fuel fill door.
  4. Stop filling the tank after the fuel nozzle automatically clicks off. Do not try to "top off" the tank. Leave some room for the fuel to expand with temperature changes.

*If the fuel nozzle keeps clicking off even though the tank is not full, there may be a problem with your vehicle's fuel vapor recovery system. The system helps keep fuel vapors from going into the atmosphere. Consult your dealer.*

5. Screw the fuel fill cap back on until it clicks at least three times. If you do not properly tighten the cap, the Malfunction Indicator Lamp may come on (see page 196).
6. Push the fuel fill door closed until it latches.

## Opening and Closing the Hood



### *To Open the Hood:*

1. Park the vehicle, and set the parking brake. Pull the hood release handle located under the lower left corner of the dashboard. The hood will pop up slightly.

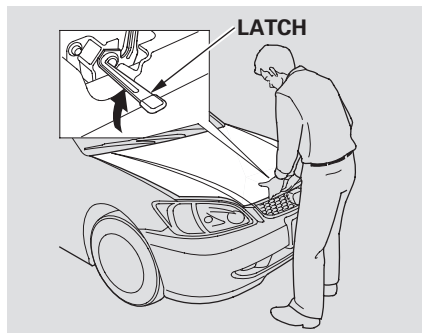

2. Put your fingers under the front edge of the hood to the right of the center. Slide your hand to the left until you feel the hood latch handle. Push this handle up to release it. Lift up the hood.

If the hood latch handle moves stiffly, or if you can open the hood without lifting the handle, the mechanism should be cleaned and lubricated.

3. Pull the support rod out of its clip, and insert the end into the hole on the front left side of the hood.

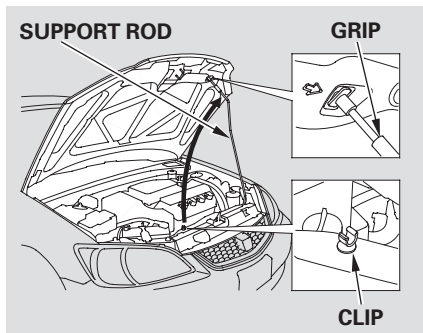

### To Close the Hood:

Lift it up slightly to remove the support rod from the hole. Put the support rod back into its holding clip. Lower the hood to about a foot (30 cm) above the fender, then let it drop. Make sure it is securely latched.

## Oil Check

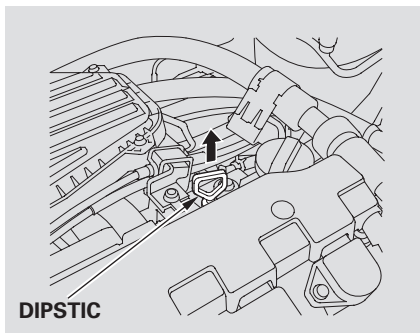

Wait a few minutes after turning the engine off before you check the oil.

1. Remove the dipstick.
2. Wipe the dipstick with a clean cloth or paper towel.
3. Insert it all the way back in its tube.

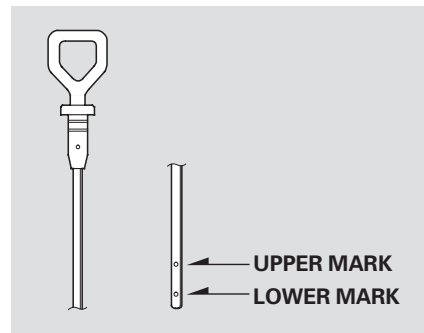

4. Remove the dipstick again and check the level. It should be between the upper and lower marks.

If it is near or below the lower mark, see **Adding Engine Oil** on page 152.



# Service Station Procedure

---

## Engine Coolant Check

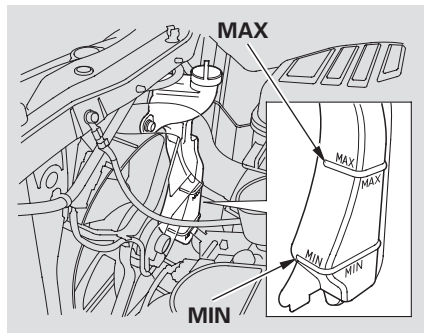

Look at the coolant level in the radiator reserve tank. Make sure it is between the MAX and MIN lines. If it is below the MIN line, see **Adding Engine Coolant** on page 157 for information on adding the proper coolant.

Refer to **Owner's Maintenance Checks** on page 144 for information on checking other items in your Honda.

## Improving Fuel Economy

- Always maintain your vehicle according to the maintenance schedule. See **Owner's Maintenance Checks** (see page [144](#)).

*For example, an underinflated tire causes more “rolling resistance,” which uses fuel.*

The build-up of snow or mud on your vehicle's underside adds weight and rolling resistance. Frequent cleaning helps your fuel mileage and reduces the chance of corrosion.

- Drive moderately. Rapid acceleration, abrupt cornering and hard braking use more fuel.
- Always drive in the highest gear possible.

- Try to maintain a constant speed. Every time you slow down and speed up, your vehicle uses extra fuel. Use the cruise control when appropriate.
- Combine several short trips into one.
- The air conditioning puts an extra load on the engine which makes it use more fuel. Use the fresh-air ventilation when possible.

# Accessories and Modifications

---

Modifying your vehicle, or installing some non-Honda accessories, can make your vehicle unsafe. Before you make any modifications or add any accessories, be sure to read the following information.

## Accessories

Your dealer has Honda accessories that allow you to personalize your vehicle. These accessories have been designed and approved for your vehicle, and are covered by warranty.

Although aftermarket accessories may fit on your vehicle, they may not meet factory specifications, and could adversely affect your vehicle's handling and stability (see "Modifications" on page 121 for additional information).

## WARNING

Improper accessories or modifications can affect your vehicle's handling, stability, and performance, and cause a crash in which you can be hurt or killed.

Follow all instructions in this owner's manual regarding accessories and modifications.

When properly installed, cellular phones, alarms, two-way radios, and low-powered audio systems should not interfere with your vehicle's computer controlled systems, such as the SRS and anti-lock brake system.

Before installing any accessory:

- Make sure the accessory does not obscure any lights, or interfere with proper vehicle operation or performance.
- Be sure electronic accessories do not overload electrical circuits (see page 199 ) or interfere with proper operation.
- Have the installer contact your Honda dealer for assistance before installing any electronic accessory.

### Modifying Your Vehicle

Removing parts from your vehicle, or replacing components with non-Honda (aftermarket) components could seriously affect your vehicle's handling, stability, and reliability.

Some examples are:

- Lowering your vehicle with an aftermarket suspension kit that significantly reduces ground clearance can allow the undercarriage to hit speed bumps or other raised objects, which could cause the airbags to deploy.
- Raising your vehicle with an aftermarket suspension kit can affect the handling and stability.
- Aftermarket wheels, because they are a universal design, can cause excessive stress on suspension components.

- Larger or smaller wheels and tires can interfere with the operation of your vehicle's anti-lock brakes and other systems.

Do not modify your steering wheel or any other part of your Supplemental Restraint System. Modifications could make the system ineffective. See the safety precautions on page 28.

If you plan to modify your vehicle, consult with your Honda dealer.

### Additional Safety Precaution

*Do not cover or replace front seat-back covers without consulting a Honda dealer.* Improperly replacing or covering front seat-back covers can prevent your side airbags from inflating during a collision.

# Carrying Cargo

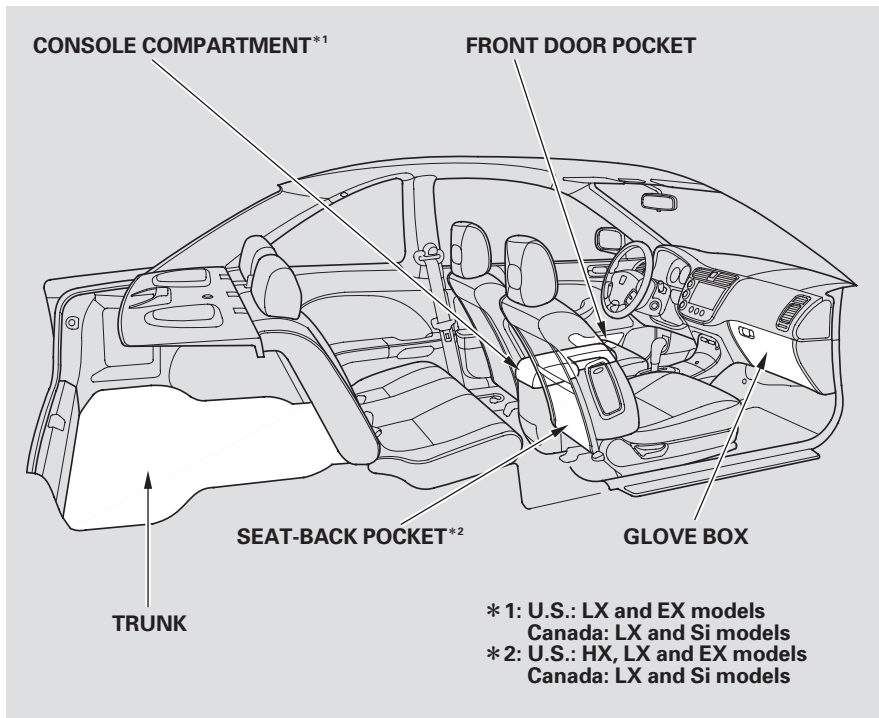

Your vehicle has several convenient storage areas:

- Glove box
- Front door and seat-back pockets
- Console compartment
- Trunk
- Roof-rack (if installed)

However, carrying too much cargo, or improperly storing it, can affect your vehicle's handling, stability, stopping distance, and tires, and make it unsafe. Before carrying any type of cargo, be sure to read the following pages.

## **⚠ WARNING**

Overloading or improper loading can affect handling and stability and cause a crash in which you can be hurt or killed.

Follow all load limits and other loading guidelines in this manual.

The maximum load for your vehicle is 850 lbs (395 kg). This figure includes total weight of all occupants, cargo, and accessories.

To determine the correct cargo and luggage load limit:

1. Locate the statement, “the combined weight of occupants and cargo should never exceed 850 lbs (395 kg)” on your vehicle’s placard (on the driver’s doorjamb).
2. Determine the combined weight of the driver and passengers that will be riding in the vehicle.
3. Subtract the combined weight of the driver and passengers from 850 lbs (395 kg).
4. The resulting figure equals the available load capacity.

For example, if there will be four 150 lbs (70 kg) occupants in your vehicle, the amount of available cargo and luggage load capacity is 250 lbs (115 kg).

$$4 \times 150 \text{ lbs (70 kg)} = 600 \text{ lbs (280 kg)}$$

$$850 \text{ lbs (395 kg)} - 600 \text{ lbs (280 kg)} = 250 \text{ lbs (115 kg)}$$

5. Determine the combined weight of accessories, luggage, and cargo being loaded in the vehicle. The weight may not safely exceed the available cargo and luggage load capacity calculated in step 4.

## Carrying Items in the Passenger Compartment

- Store or secure all items that could be thrown around and hurt someone during a crash.
- Do not put any items on top of the rear shelf. They can block your view and be thrown around the vehicle during a crash.
- Be sure items placed on the floor behind the front seats cannot roll under the seats and interfere with the pedals or seat operation.
- Keep the glove box closed while driving. If it is open, a passenger could injure their knees during a crash or sudden stop.

## Carrying Cargo

---

### Carrying Cargo in the Trunk or on a Roof Rack

- Distribute cargo evenly on the floor of the cargo area, placing the heaviest items on the bottom and as far forward as possible.
- If you fold down the back seat, tie down items that could be thrown about the vehicle during a crash or sudden stop.
- If you carry large items that prevent you from closing the trunk lid, exhaust gas can enter the passenger area. To avoid the possibility of **carbon monoxide poisoning**, follow the instructions on page [47](#).
- If you can carry any items on a roof rack, be sure the total weight of the rack and the items does not exceed the maximum load (850 lbs/395 kg). Please contact your Honda dealer for further information.

This section gives you tips on starting the engine under various conditions, and how to operate the 5-speed manual and automatic transmissions. It also includes important information on parking your vehicle, and the braking system.

Preparing to Drive .....	126
Starting the Engine.....	127
5-speed Manual Transmission .....	128
Automatic Transmission.....	130
Automatic Transmission (CVT) ..	134
Parking.....	137
Braking System.....	138
Towing a Trailer .....	138
Anti-lock Brakes (ABS) .....	139



## Preparing to Drive

---

You should do the following checks and adjustments every day before you drive your vehicle.

1. Make sure all windows, mirrors, and outside lights are clean and unobstructed. Remove frost, snow, or ice.
2. Check that the hood and trunk are fully closed.
3. Visually check the tires. If a tire looks low, use a gauge to check its pressure.
4. Check that any items you may be carrying are stored properly or fastened down securely.
5. Check the seat adjustment (see page [76](#) ).
6. Check the adjustment of the inside and outside mirrors (see page [83](#) ).
7. Check the steering wheel adjustment (see page [68](#) ).
8. Make sure the doors are securely closed and locked.
9. Fasten your seat belt. Check that your passengers have fastened their seat belts (see page [14](#) ).
10. When you start the engine, check the gauges and indicator lights in the instrument panel (see page [53](#) ).

1. Apply the parking brake.
2. In cold weather, turn off all electrical accessories to reduce the drain on the battery.
3. *Manual Transmission:*  
Push the clutch pedal down all the way.  
  
*Automatic Transmission:*  
Make sure the shift lever is in Park. Press on the brake pedal.
4. Without touching the accelerator pedal, turn the ignition key to the START (III) position. Do not hold the key in START for more than 15 seconds at a time. If the engine does not start right away, pause for at least 10 seconds before trying again.

5. If the engine does not start within 15 seconds, or starts but stalls right away, repeat step 4 with the accelerator pedal pressed halfway down. If the engine starts, release pressure on the accelerator pedal so the engine does not race.
6. If the engine fails to start, press the accelerator pedal all the way down and hold it there while starting to clear flooding. If the engine still does not start, return to step 5.

**NOTICE:** *The engine is harder to start in cold weather. Also, the thinner air found at altitudes above 8,000 feet (2,400 meters) adds to this problem.*

## 5-speed Manual Transmission

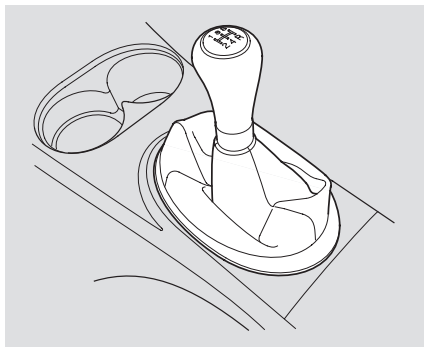

The manual transmission is synchronized in all forward gears for smooth operation. It has a lockout so you cannot shift directly from Fifth to Reverse. When shifting up or down, make sure you push the clutch pedal down all the way, shift to the next gear, and let the pedal up gradually. When you are not shifting, do not rest your foot on the clutch pedal. This can cause your clutch to wear out faster.

Come to a full stop before you shift into Reverse. You can damage the transmission by trying to shift into Reverse with the vehicle moving. Push down the clutch pedal, and pause for a few seconds before shifting into Reverse, or shift into one of the forward gears for a moment. This stops the gears so they won't "grind."

When slowing down, you can get extra braking from the engine by shifting to a lower gear. This extra braking can help you maintain a safe speed and prevent your brakes from overheating while going down a steep hill. Before downshifting, make sure the vehicle speed is low enough that you will not activate the engine speed limiter in the lower gear. On all models except U.S. DX, make sure the engine speed will not go into the tachometer's red zone in the lower gear before downshifting.

### **WARNING**

Rapid slowing or speeding-up can cause loss of control on slippery surfaces. If you crash, you can be injured.

Use extra care when driving on slippery surfaces.

**Recommended Shift Points**

Drive in the highest gear that lets the engine run and accelerate smoothly. This will give you good fuel economy and effective emissions control. The following shift points are recommended:

Shift up	Normal acceleration
1st to 2nd	15 mph (24 km/h)
2nd to 3rd	27 mph (43 km/h)
3rd to 4th	39 mph (63 km/h)
4th to 5th	53 mph (85 km/h)

Shift up	Cruise from acceleration
1st to 2nd	9 mph (14 km/h)
2nd to 3rd	20 mph (32 km/h)
3rd to 4th	33 mph (53 km/h)
4th to 5th	48 mph (77 km/h)

**Engine Speed Limiter**

*All models except U.S. DX*

If you exceed the maximum speed for the gear you are in, the engine speed will enter into the tachometer's red zone. If this occurs, you may feel the engine cut in and out. This is caused by a limiter in the engine's computer controls. The engine will run normally when you reduce the RPM below the red zone.

Before downshifting, make sure the engine will not go into the tachometer's red zone.

*U.S. DX model*

If you exceed the maximum speed for the gear you are in, you may feel the engine cut in and out. This is caused by a limiter in the engine's computer controls. The engine will run normally when you reduce the engine speed by upshifting or slowing down.

Before downshifting, make sure the vehicle speed is low enough that you will not activate the engine speed limiter in the lower gear.

# Automatic Transmission

## Shift Lever Position Indicators

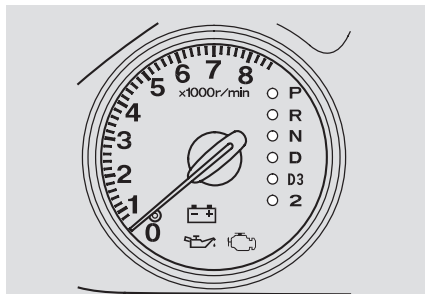

U.S.: LX, EX, Canada: LX, Si

These indicators on the instrument panel show which position the shift lever is in.

The “D” indicator comes on for a few seconds when you turn the ignition switch to ON (II). If it flashes while driving (in any shift position), it indicates a possible problem in the transmission. Avoid rapid acceleration and have the transmission checked by a Honda dealer as soon as possible.

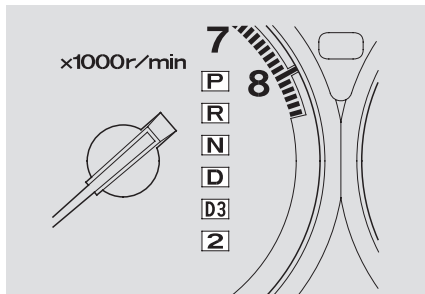

Canada: DX

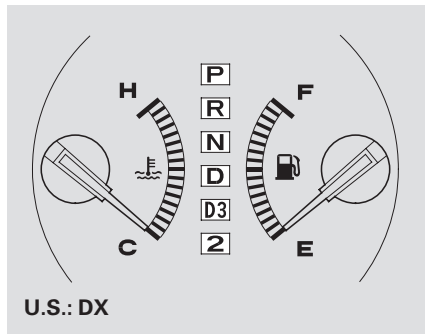

U.S.: DX

## Shifting

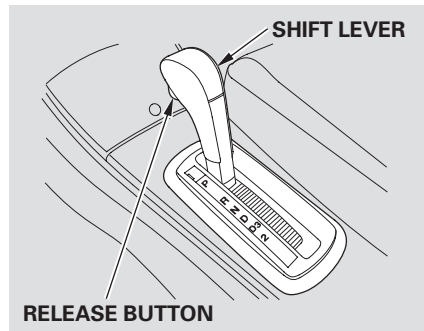

To shift from any position, press firmly on the brake pedal and press the release button on the front of the shift lever. You cannot shift out of Park when the ignition switch is in LOCK (0) or ACCESSORY (I).

To shift from:	Do this:
P to R	Press the brake pedal and press the release button.
R to P N to R D <sub>3</sub> to 2	Press the release button.
2 to D <sub>3</sub> D <sub>3</sub> to D D to N D to D <sub>3</sub> N to D R to N	Move the lever.

**Park (P)** — This position mechanically locks the transmission. Use Park whenever you are turning off or starting the engine. To shift out of Park, you must press on the brake pedal and have your foot off the accelerator pedal.

If you have done all of the above and still cannot move the lever out of Park, see **Shift Lock Release** on page [133](#).

To avoid transmission damage, come to a complete stop before shifting into Park. The shift lever must be in Park before you can remove the key from the ignition switch.

**Reverse (R)** — Press the brake pedal and press the release button to the front of shift lever to shift from Park to Reverse. To shift from Reverse to Neutral, come to a complete stop and then shift.

**Neutral (N)** — Use Neutral if you need to restart a stalled engine, or if it is necessary to stop briefly with the engine idling. Shift to the Park position if you need to leave your vehicle for any reason. Press on the brake pedal when you are moving the shift lever from Neutral to another gear.

**Drive (D)** — Use this position for your normal driving. The transmission automatically selects a suitable gear for your speed and acceleration. You may notice the transmission shifting up at higher speeds when the engine is cold. This helps the engine warm up faster.

**Drive (D<sub>3</sub>)** — This position is similar to D, except only the first three gears are selected. Use D<sub>3</sub> to provide engine braking when going down a steep hill. D<sub>3</sub> can also keep the transmission from cycling between third and fourth gears in stop-and-go driving.

*CONTINUED*

# Automatic Transmission

---

**Second (2)** – This position locks the transmission in second gear. It does not downshift to first gear when you come to a stop.

Use Second gear:

- For more power when climbing.
- To increase engine braking when going down steep hills.
- For starting out on a slippery surface or in deep snow.

## **Engine Speed Limiter**

*All models except U.S. DX*

If you exceed the maximum speed for the gear you are in, the engine speed will enter into the tachometer's red zone. If this occurs, you may feel the engine cut in and out. This is caused by a limiter in the engine's computer controls. The engine will run normally when you reduce the RPM below the red zone.

*U.S. DX model*

If you exceed the maximum speed for the gear you are in, you may feel the engine cut in and out. This is caused by a limiter in the engine's computer controls. The engine will run normally when you reduce the engine speed by upshifting or slowing down.

## Shift Lock Release

Do this if pushing on the brake pedal and pressing the release button does not shift the transmission out of park:

1. Set the Parking brake.
2. Remove the key from the ignition switch.

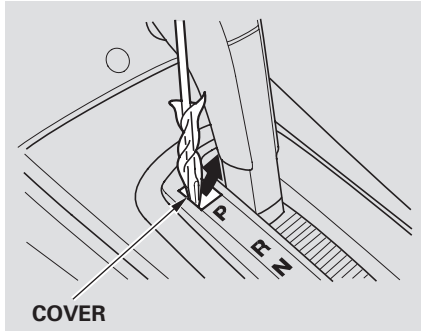

3. Put a cloth on the edge of the Shift Lock Release slot cover next to the shift lever. Using a small flat-tipped screwdriver or small metal plate, carefully pry on the edge of the cover to remove it.
4. Insert the key in the Shift Lock Release slot.
5. Push down on the key while you press the release button on the shift lever and move the shift lever out of Park to Neutral.

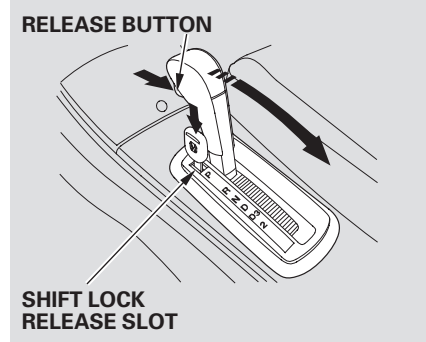

6. Remove the key from the Shift Lock Release slot, then reinstall the cover. Make sure the notch on the cover is on the left side. Return the key to the ignition switch, press the brake pedal, and restart the engine.

If you need to use the Shift Lock Release, it means your vehicle is developing a problem. Have it checked by a Honda dealer.



# Automatic Transmission (CVT)

## Continuously Variable Transmission (CVT)

*On HX model*

Honda's Continuously Variable Transmission's unique design provides a smooth, constant flow of power. It is electronically controlled for more precise operation and better fuel economy.

## Shift Lever Position Indicators

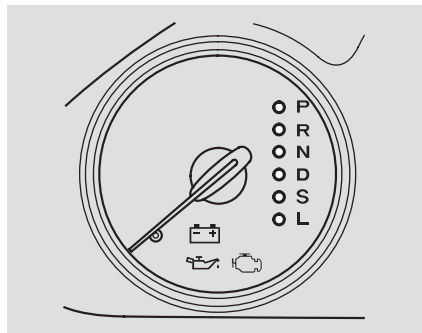

These indicators on the instrument panel show which position the shift lever is in.

The "D" indicator comes on for a few seconds when you turn the ignition switch to ON (II). If it flashes while driving (in any shift position), it indicates a possible problem in the transmission. Avoid rapid acceleration and have the transmission checked by a Honda dealer as soon as possible.

## Shifting

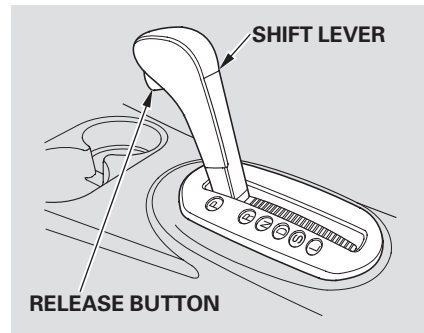

To shift from any position, press the release button on the front of the shift lever. You cannot shift out of Park when the ignition switch is in LOCK (0) or ACCESSORY (I).

To shift from:	Do this:
P to R	Press the brake pedal and press the release button.
R to P N to R S to L	Press the release button.
L to S S to D D to S D to N N to D R to N	Move the lever.

**Park (P)** – This position mechanically locks the transmission. Use Park whenever you are turning off or starting the engine. To shift out of Park, you must press on the brake pedal and have your foot off the accelerator pedal. If you have done all of the above and still cannot move the lever out of Park, see **Shift Lock Release** on page [133](#).

To avoid transmission damage, come to a complete stop before shifting into Park. The shift lever must be in Park before you can remove the key from the ignition switch.

**Reverse (R)** – To shift from Reverse to Park, see the explanation under Park. To shift to Reverse from Neutral, come to a complete stop first. Press the release button before shifting into Reverse from Neutral.

**Neutral (N)** – Use Neutral if you need to restart a stalled engine, or if it is necessary to stop briefly with the engine idling. Shift to the Park position if you need to leave your vehicle for any reason. Press on the brake pedal when you are moving the shift lever from Neutral to another gear.

*CONTINUED*

## Automatic Transmission (CVT)

---

**Drive (D)** — Use this position for your normal driving. The transmission automatically adjusts to keep the engine at the best speed for driving conditions. To help the engine warm up faster, the transmission will select ratios that allow the engine to run at higher speeds when it is cold.

**Second (S)** — Selecting Second shifts the transmission into a lower range of ratios for better acceleration and increased engine braking. Use Second when you are going down a steep hill, or in stop-and-go driving.

**Low (L)** — To shift to Low, press the release button on the front of the shift lever. Use Low to get more power when climbing, and for maximum engine braking when going down steep hills.

For faster acceleration when in D, S or L, the transmission will automatically “kick down” to a lower range of ratios by pushing the accelerator pedal to the floor.

### **Maximum Allowable Speeds**

The CVT shifts automatically to maintain proper engine speed in any shift position.

When the vehicle reaches the maximum speed in any shift position, you may feel the engine cut in and out. This is caused by a limiter (112 mph, 180 km/h) in the engine’s computer controls. The engine will run normally when you reduce the speed to below the maximum.

Always use the parking brake when you park your vehicle. Make sure the parking brake is set firmly or your vehicle may roll if it is on an incline.

If your vehicle has an automatic transmission, set the parking brake before you put the transmission in Park. This keeps the vehicle from moving and putting pressure on the parking mechanism in the transmission.

## **Parking Tips**

- Make sure the moonroof and the windows are closed.
- Turn off the lights.
- Place any packages, valuables, etc. in the trunk or take them with you.
- Lock the doors.
- Never park over dry leaves, tall grass, or other flammable materials. The hot three way catalytic converter could cause these materials to catch on fire.
- If the vehicle is facing uphill, turn the front wheels away from the curb. If you have a manual transmission, put it in first gear.
- If the vehicle is facing downhill, turn the front wheels toward the curb. If you have a manual transmission, put it in reverse gear.
- Make sure the parking brake is fully released before driving away. Driving with the parking brake partially set can overheat or damage the rear brakes.

# Braking System, Towing a Trailer

## Braking System

All Civics are equipped with front disc brakes. The brakes on the rear wheels are drum. A power assist helps reduce the effort needed on the brake pedal. The ABS (on some models) helps you retain steering control when braking very hard.

Resting your foot on the pedal keeps the brakes applied lightly, builds up heat, and reduces their effectiveness. It also keeps your brake lights on all the time, confusing drivers behind you.

Constant application of the brakes when going down a long hill builds up heat and reduces their effectiveness. Use the engine to assist the brakes by taking your foot off the accelerator and downshifting to a lower gear.

Check the brakes after driving through deep water. Apply the brakes moderately to see if they feel normal. If not, apply them gently and frequently until they do. Be extra cautious in your driving.

## Braking System Design

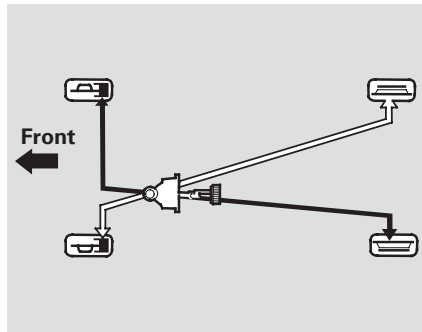

The hydraulic system that operates the brakes has two separate circuits. Each circuit works diagonally across the vehicle (the left-front brake is connected with the right-rear brake,

etc.). If one circuit should develop a problem, you will still have braking at two wheels.

## Brake Wear Indicators

If the brake pads need replacing, you will hear a distinctive, metallic screeching sound when you apply the brake pedal. If you do not have the brake pads replaced, they will screech all the time. It is normal for the brakes to occasionally squeal or squeak when you apply them.

## Towing a Trailer

Your vehicle is not designed to tow a trailer. Attempting to do so can void your warranties.

*On U.S. EX and Canadian Si-G models*  
The Anti-lock Brake System (ABS) helps prevent the brakes from locking up and helps you retain steering control by pumping the brakes rapidly, much faster than a person can do it.

*You should never pump the brake pedal.* Let the ABS work for you by always keeping firm, steady pressure on the brake pedal. This is sometimes referred to as “stomp and steer.”

You will feel a pulsation in the brake pedal when the ABS activates, and you may hear some noise. This is normal: it is the ABS rapidly pumping the brakes. On dry pavement, you will need to press on the brake pedal very hard before the ABS activates. However, you may feel the ABS activate immediately if you are trying to stop on snow or ice.

## ABS Indicator

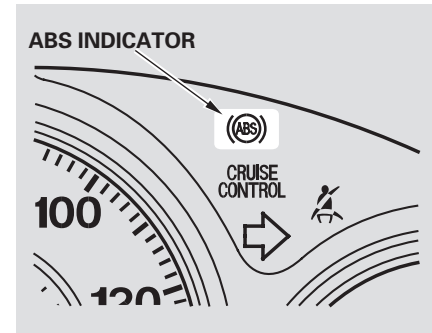

The ABS is self-checking each time the vehicle is started and moved. The ABS indicator will come on if anything goes wrong. If the ABS indicator comes on, the brakes still work like a conventional system, but without anti-lock. You should have a dealer inspect your vehicle as soon as possible.

*CONTINUED*

## Anti-lock Brakes (ABS)

---

### *Important Safety Reminders*

**ABS does not reduce the time or distance it takes to stop the vehicle.** It only helps with the steering control during braking.

**ABS will not prevent a skid that results from changing direction abruptly,** such as trying to take a corner too fast or making a sudden lane change. Always drive at a safe speed for the road and weather conditions.

**ABS cannot prevent a loss of stability.** Always steer moderately when you are braking hard. Severe or sharp steering wheel movement can still cause your vehicle to veer into oncoming traffic or off the road.

**A vehicle with ABS may require a longer distance to stop** on loose or uneven surfaces, such as gravel or snow, than a vehicle without anti-lock. Slow down and allow a greater distance between vehicles under those conditions.

This section explains why it is important to keep your vehicle well maintained and how to follow basic maintenance safety precautions.

This section also includes Maintenance Schedules for normal driving and severe driving conditions, a Maintenance Record, and instructions for simple maintenance tasks you may want to take care of yourself.

If you have the skills and tools to perform more complex maintenance tasks on your Honda, you may want to purchase the Service Manual. See page 221 for information on how to obtain a copy, or see your Honda dealer.

Maintenance Safety.....	142
Maintenance Schedule.....	143
Maintenance Record.....	149
Fluid Locations.....	151
Adding Engine Oil.....	152
Changing the Oil and Filter.....	154
Windshield Washers.....	156
Engine Coolant.....	157
Power Steering Fluid.....	159
Automatic Transmission Fluid....	160
Manual Transmission Fluid.....	162
Timing Belt.....	162
Brake and Clutch Fluid.....	163
Lights.....	164
Seat Belts.....	169
Floor Mats.....	169
Dust and Pollen Filter.....	169
Wiper Blades.....	170
Tires.....	172
Checking the Battery.....	178
Vehicle Storage.....	179



All service items not detailed in this section should be performed by a Honda technician or qualified mechanic.

## Important Safety Precautions

To eliminate potential hazards, read the instructions before you begin, and make sure you have the tools and skills required.

- Make sure your vehicle is parked on level ground, the parking brake is set, and the engine is off.
- To clean parts, use a commercially available degreaser or parts cleaner, not gasoline.
- To reduce the possibility of fire or explosion, keep cigarettes, sparks, and flames away from the battery and all fuel-related parts.
- Wear eye protection and protective clothing when working

with the battery or compressed air.

## WARNING

Improperly maintaining this vehicle or failing to correct a problem before driving can cause a crash in which you can be seriously hurt or killed.

Always follow the inspection, maintenance recommendations, and schedules in this owner's manual.

## Potential Vehicle Hazards

- **Carbon Monoxide poison from engine exhaust.** Be sure there is adequate ventilation whenever you operate the engine.
- **Burns from hot parts.** Let the engine and exhaust system cool before touching any parts.

- **Injury from moving parts.** Do not run the engine unless instructed to do so.

## WARNING

Failure to properly follow maintenance instructions and precautions can cause you to be seriously hurt or killed.

Always follow the procedures and precautions in this owner's manual.

Some of the most important safety precautions are given here. However, we cannot warn you of every conceivable hazard that can arise in performing maintenance. Only you can decide whether or not you should perform a given task.

The maintenance schedule assumes you will use your vehicle as normal transportation for passengers and their possessions. You should also follow these recommendations:

- Avoid exceeding your vehicle's load limit. This puts excess stress on the engine, brakes, and many other vehicle parts. The load limit is shown on the tire information label on the driver's doorjamb.
- Operate your vehicle on reasonable roads within the legal speed limit.
- Drive your vehicle regularly over a distance of several miles (kilometers).
- Always use unleaded gasoline with the proper octane rating (see page [114](#)).

## Which Schedule to Follow

Service your vehicle according to the time and mileage periods on one of the Maintenance Schedules on the following pages.

**U.S. Owners** — Follow the Maintenance Schedule for Severe Conditions if you drive your vehicle **MAINLY** under one or more of the following conditions.

- Driving less than 5 miles (8 km) per trip or, in freezing temperatures, driving less than 10 miles (16 km) per trip.
- Driving in extremely hot [over 90°F (32°C)] conditions.
- Used primarily as a delivery vehicle or taxi that is driven mostly in stop-and-go traffic and/or parked with the engine idling.

- Driving with a roof rack, or driving in mountainous conditions.
- Driving on muddy, dusty, or de-iced roads.

**NOTE:** If you only *OCCASIONALLY* drive under “severe” conditions, you should follow the Normal Conditions Maintenance Schedule.

**Canadian Owners** — Follow the Maintenance Schedule for Severe Conditions.

*CONTINUED*

# Maintenance Schedule

---

Your authorized Honda dealer knows your vehicle best and can provide competent, efficient service. However, service at a dealer is not mandatory to keep your warranties in effect. Maintenance may be done by any qualified service facility or skilled person to keep your warranty in effect. Keep all the receipts as proof of completion, and have the person who does the work fill out the Maintenance Record. Check your warranty booklet for more information.

We recommend the use of Honda parts and fluids whenever you have maintenance done.

**U.S. Vehicles:**  
**Maintenance, replacement, or repair of emissions control devices and systems may be done by any automotive repair establishment or individual using parts that are “certified” to EPA standards.**

According to state and federal regulations, failure to perform maintenance on the items marked with # will not void your emissions warranties. However, Honda recommends that all maintenance services be performed at the recommended time or mileage period to ensure long-term reliability.

## **Owner’s Maintenance Checks**

You should check the following items at the specified intervals. If you are unsure of how to perform any check, turn to the appropriate page listed.

- Engine oil level — Check every time you fill the fuel tank. See page [117](#) .
- Engine coolant level — Check the radiator reserve tank every time you fill the fuel tank. See page [118](#) .
- Automatic transmission — Check the fluid level monthly. See page [160](#) .
- Brakes — Check the fluid level monthly. See page [163](#) .
- Tires — Check the tire pressure monthly. Examine the tread for wear and foreign objects. See page [172](#) .
- Lights — Check the operation of the headlights, parking lights, taillights, high-mount brake light, and license plate lights monthly. See page [164](#) .

Service the items listed at the indicated distance (or time, if given).																	
	miles x 1,000	10	20	30	40	50	60	70	80	90	100	110	120	130	140	150	
	km x 1,000	16	32	48	64	80	96	112	128	144	160	176	192	208	224	240	
Check engine oil and coolant		Check oil and coolant at each fuel stop															
Check tires		Check inflation and condition once a month															
Replace engine oil		•	•	•	•	•	•	•	•	•	•	•	•	•	•	•	•
		<i>(Or every 1 year, whichever comes first)</i>															
Rotate tires (follow pattern on page 175 )		Every 10,000 miles (16,000 km)															
Replace engine oil filter																	
Check front and rear brakes																	
Check parking brake adjustment																	
Inspect the following items:																	
Tie rod ends, steering gear box, and boots																	
Suspension components			•		•		•		•		•		•		•		•
Driveshaft boots																	
Brake hoses and lines (including ABS)																	
All fluid levels and condition of fluids																	
Exhaust system <sup>#</sup>																	
Fuel lines and connections <sup>#</sup>																	
Inspect and adjust drive belts				•			•			•			•				•
Replace dust and pollen filter																	
Replace air cleaner element				•			•			•			•				•

# : See information on maintenance and emission warranty on page 144.

Follow the Normal Maintenance Schedule if the severe driving conditions specified in the Severe Conditions Maintenance Schedule on page 147 do not apply.

NOTE: If you only OCCASIONALLY drive under “severe” conditions, you should follow the Normal Conditions Maintenance Schedule.

CONTINUED

Service the items listed at the indicated distance (or time, if given).																
	miles x 1,000	10	20	30	40	50	60	70	80	90	100	110	120	130	140	150
	km x 1,000	16	32	48	64	80	96	112	128	144	160	176	192	208	224	240
Replace spark plugs													●			
Inspect valve clearance													●			
Replace automatic transmission fluid* <sup>1</sup>													●			
Replace manual transmission fluid													●			
Replace CVT transmission fluid* <sup>2</sup>							●					●				●
Inspect idle speed													●			
Replace timing belt, and inspect auto-tensioner and water pump													●			
Replace engine coolant		120,000 miles (192,000 km) or 10 years, then every 60,000 miles (96,000 km) or 5 years														
Replace brake fluid		Every 3 years (independent of mileage)														

\* 1: Replace at 120,000 miles (192,000 km) or 6 years, then every 90,000 miles (144,000 km) or 5 years.

\* 2: Replace at 60,000 miles (96,000 km) or 3 years, then every 40,000 miles (64,000 km) or 2 years.

Service the items listed at the indicated distance (or time, if given).		miles x 1,000														
		10	20	30	40	50	60	70	80	90	100	110	120	130	140	150
		km x 1,000														
Check engine oil and coolant	Check oil and coolant at each fuel stop															
Check tires	Check inflation and condition once a month															
Replace engine oil	Every 5,000 miles (8,000 km) or every 6 months, whichever comes first															
Rotate tires (follow pattern on page 175 )	Every 10,000 miles (16,000 km)															
Replace engine oil filter																
Check front and rear brakes																
Lubricate all hinges, locks and latches	•	•	•	•	•	•	•	•	•	•	•	•	•	•	•	
Inspect the following items: Tie rod ends, steering gear box, and boots Suspension components, Driveshaft boots																
Check parking brake adjustment																
Inspect the following items: Brake hoses and lines (including ABS) All fluid levels and condition of fluids Exhaust system <sup>±</sup> , Fuel lines and connections <sup>±</sup> Lights and controls/vehicle underbody		•		•		•		•		•		•		•		
Inspect and adjust drive belts			•			•			•			•			•	
Replace dust and pollen filter* <sup>1</sup>																
Replace air cleaner element	Every 15,000 miles (24,000 km) (Use normal schedule except in dusty conditions)															

\* 1 : See dust and pollen filter on page 169 for replacement information under special driving conditions.

# : See information on maintenance and emission warranty on page 144 .

Follow the Severe Maintenance Schedule if you drive your vehicle MAINLY under one or more of the following conditions:

- Driving less than 5 miles (8 km) per trip or, in freezing temperatures, driving less than 10 miles (16 km) per trip.
- Driving in extremely hot [over 90°F (32°C)] conditions.
- Extensive idling or long periods of stop and go driving, such as a taxi or a commercial delivery vehicle.
- Driving with a roof rack, or driving in mountainous conditions.
- Driving on muddy, dusty, or de-iced roads.

**For Canadian Owners** – Follow the Maintenance Schedule for Severe Conditions.

CONTINUED

Service the items listed at the indicated distance (or time, if given).																	
	miles x 1,000	10	20	30	40	50	60	70	80	90	100	110	120	130	140	150	
	km x 1,000	16	32	48	64	80	96	112	128	144	160	176	192	208	224	240	
Replace spark plugs												●					
Inspect valve clearance												●					
								<i>(Otherwise adjust only if noisy)</i>									
Replace automatic transmission fluid* <sup>1</sup>							●			●			●			●	
Replace manual transmission fluid							●						●				
								<i>(Or every 3 years, whichever comes first)</i>									
Replace CVT transmission fluid* <sup>2</sup>							●				●					●	
Inspect idle speed													●				
Replace timing belt* <sup>3</sup> , inspect auto-tensioner and water pump													●				
								<i>(Or every 7 years, whichever comes first)</i>									
Replace engine coolant		120,000 miles (192,000 km) or 10 years, then every 60,000 miles (96,000 km) or 5 years															
Replace brake fluid		Every 3 years (independent of mileage)															

\* 1: Replace at 60,000 miles (96,000 km) or 3 years, then every 30,000 miles (48,000 km) or 2 years.

\* 2: Replace at 60,000 miles (96,000 km) or 3 years, then every 40,000 miles (64,000 km) or 2 years.

\* 3: See timing belt on page 162 for replacement information under special driving conditions.

# Maintenance Record *(for Normal and Severe Schedules)*

You or the servicing dealer can record all completed maintenance here, whether you follow the schedule for normal conditions (page 145) or severe conditions (page 147). Keep the receipts for all work done on your vehicle.

<b>5,000 mi</b> 8,000 km	Signature or dealer stamp	mi/km
		Date
<b>10,000 mi</b> 16,000 km		mi/km
		Date
<b>15,000 mi</b> 24,000 km		mi/km
		Date
<b>20,000 mi</b> 32,000 km (or 1 year)		mi/km
		Date
<b>25,000 mi</b> 40,000 km		mi/km
		Date
<b>30,000 mi</b> 48,000 km		mi/km
		Date
<b>35,000 mi</b> 56,000 km		mi/km
		Date
<b>40,000 mi</b> 64,000 km (or 2 years)		mi/km
		Date

<b>45,000 mi</b> 72,000 km	Signature or dealer stamp	mi/km
		Date
<b>50,000 mi</b> 80,000 km		mi/km
		Date
<b>55,000 mi</b> 88,000 km		mi/km
		Date
<b>60,000 mi</b> 96,000 km (or 3 years)		mi/km
		Date
<b>65,000 mi</b> 104,000 km		mi/km
		Date
<b>70,000 mi</b> 112,000 km		mi/km
		Date
<b>75,000 mi</b> 120,000 km		mi/km
		Date
<b>80,000 mi</b> 128,000 km (or 4 years)		mi/km
		Date

*CONTINUED*



# Maintenance Record *(for Normal and Severe Schedules)*

<b>85,000 mi</b> 136,000 km	Signature or dealer stamp	mi/km
		Date
<b>90,000 mi</b> 144,000 km		mi/km
		Date
<b>95,000 mi</b> 152,000 km		mi/km
		Date
<b>100,000 mi</b> 160,000 km (or 5 years)		mi/km
		Date
<b>105,000 mi</b> 168,000 km		mi/km
		Date
<b>110,000 mi</b> 176,000 km		mi/km
		Date
<b>115,000 mi</b> 184,000 km		mi/km
		Date
<b>120,000 mi</b> 192,000 km (or 6 years)		mi/km
		Date

<b>125,000 mi</b> 200,000 km	Signature or dealer stamp	mi/km
		Date
<b>130,000 mi</b> 208,000 km		mi/km
		Date
<b>135,000 mi</b> 216,000 km		mi/km
		Date
<b>140,000 mi</b> 224,000 km (or 7 years)		mi/km
		Date
<b>145,000 mi</b> 232,000 km		mi/km
		Date
<b>150,000 mi</b> 240,000 km		mi/km
		Date
<b>155,000 mi</b> 248,000 km		mi/km
		Date
<b>160,000 mi</b> 256,000 km (or 8 years)		mi/km
		Date

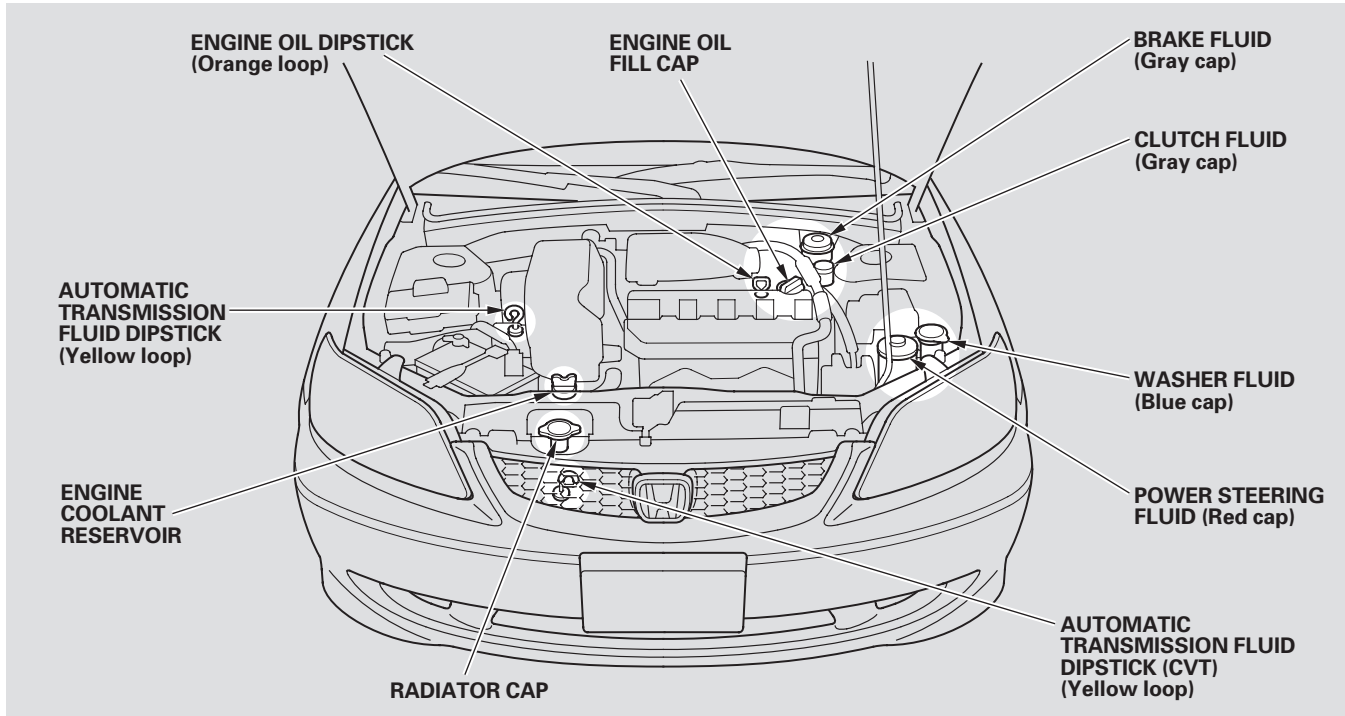

# Adding Engine Oil

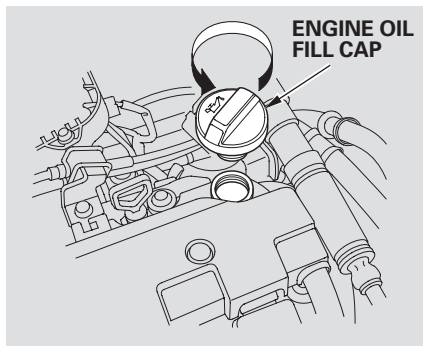

Unscrew and remove the engine oil fill cap on top of the valve cover. Pour in the oil slowly and carefully so you do not spill any. Clean up any spills immediately. Spilled oil could damage components in the engine compartment. Install the engine oil fill cap and tighten it securely. Wait a few minutes and recheck the oil level. Do not fill above the upper mark; you could damage the engine.

**Recommended Engine Oil**  
Oil is a major contributor to your engine's performance and longevity. Always use a premium-grade 5W-20 detergent oil displaying the API Certification Seal. This seal indicates the oil is energy conserving, and that it meets the American Petroleum Institute's latest requirements.



Honda Motor Oil is the preferred 5W-20 lubricant for your vehicle. It is highly recommended that you use Honda Motor Oil in your vehicle for optimum engine protection. Make sure the API Certification Seal says "For Gasoline Engines".

The oil viscosity or weight is provided on the container's label. 5W-20 oil is formulated for year-round protection of your Honda to improve cold weather starting and fuel economy.

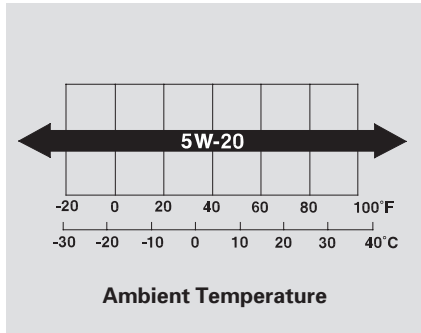

## Synthetic Oil

You may use a synthetic motor oil if it meets the same requirements given for a conventional motor oil: it displays the API Certification Seal and it is the proper weight. You must follow the oil and filter change intervals given in the maintenance schedule.

## Additives

Your Honda does not require any oil additives. Additives may adversely affect your engine's or transmission's performance and durability.

# Changing the Oil and Filter

Always change the oil and filter according to the recommendations in the maintenance schedule. The oil and filter collect contaminants that can damage your engine if they are not removed regularly.

Changing the oil and filter requires special tools and access from underneath the vehicle. The vehicle should be raised on a service station-type hydraulic lift for this service. Unless you have the knowledge and proper equipment, you should have this maintenance done by a skilled mechanic.

1. Run the engine until it reaches normal operating temperature, then shut it off.

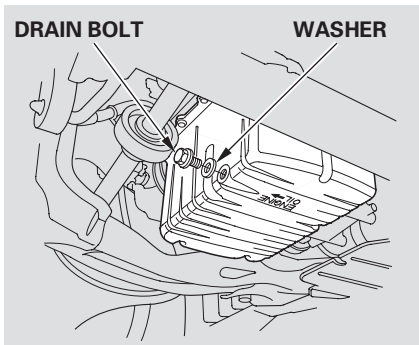

2. Open the hood and remove the engine oil fill cap. Remove the oil drain bolt and washer from the bottom of the engine. Drain the oil into an appropriate container.

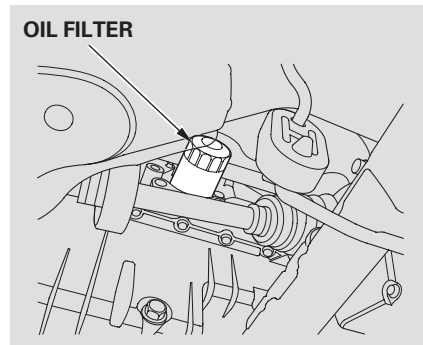

3. Remove the oil filter and let the remaining oil drain. A special wrench (available from your Honda dealer) is required.
4. Install a new oil filter according to the instructions that come with it.

5. Put a new washer on the drain bolt, then reinstall the drain bolt. Tighten it to:

(U.S.: DX, LX, Canada: DX, LX)  
33 lbf·ft (44 N·m , 4.5 kgf·m)

(U.S.: EX, HX, Canada: Si)  
29 lbf·ft (39 N·m , 4.0 kgf·m)

6. Refill the engine with the recommended oil.

Engine oil change capacity  
(including filter):

(U.S.: DX, LX, Canada: DX, LX)  
3.4 US qt (3.2 ℓ)

(U.S.: EX, HX, Canada: Si)  
3.7 US qt (3.5 ℓ)

7. Replace the engine oil fill cap. Start the engine. The oil pressure indicator light should go out within 5 seconds. If it does not, turn off the engine and check your work.

8. Let the engine run for several minutes, then check the drain bolt and oil filter for leaks.

9. Turn off the engine and let it sit for several minutes, then check the oil level. If necessary, add more oil.

**NOTICE:** *Improper disposal of engine oil can be harmful to the environment. If you change your own oil, please dispose of the used oil properly. Put it in a sealed container and take it to a recycling center. Do not discard it in a trash bin or dump it on the ground.*

## Windshield Washers

---

Check the level in the windshield washer reservoir at least monthly during normal usage.

*On Canadian models:* The low washer level indicator will light when the level is low.

Fill the reservoir with a good-quality windshield washer fluid. This increases the cleaning capability and prevents freezing in cold weather.

When you refill the reservoir, clean the edges of the windshield wiper blades with windshield washer fluid on a clean cloth. This will help to condition the blade edges.

**NOTICE:** *Do not use engine antifreeze or a vinegar/water solution in the windshield washer reservoir. Antifreeze can damage your vehicle's paint, while a vinegar/water solution can damage the windshield washer pump. Use only commercially-available windshield washer fluid.*

## Adding Engine Coolant

RESERVE TANK

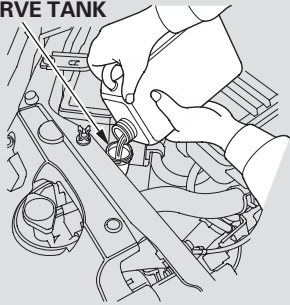

If the coolant level in the reserve tank is at or below the MIN line, add coolant to bring it up to the MAX line. Inspect the cooling system for leaks.

Always use Honda All Season Antifreeze/Coolant Type 2. This coolant is pre-mixed with 50 percent antifreeze and 50 percent water. Never add straight antifreeze or plain water.

If Honda antifreeze/coolant is not available, you may use another major-brand non-silicate coolant as a temporary replacement. Make sure it is a high-quality coolant recommended for aluminum engines. Continued use of any non-Honda coolant can result in corrosion, causing the cooling system to malfunction or fail. Have the cooling system flushed and refilled with Honda antifreeze/coolant as soon as possible.

If the reserve tank is completely empty, you should also check the coolant level in the radiator.

## **⚠ WARNING**

Removing the radiator cap while the engine is hot can cause the coolant to spray out, seriously scalding you.

Always let the engine and radiator cool down before removing the radiator cap.

*CONTINUED*



# Engine Coolant

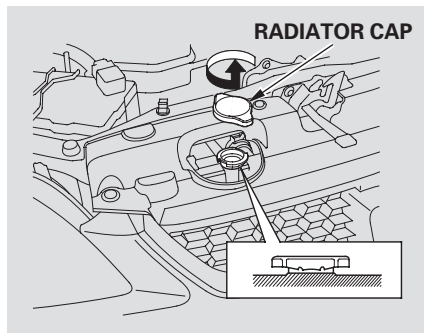

1. When the radiator and engine are cool, relieve any pressure in the cooling system by turning the radiator cap counterclockwise, without pressing down.
2. Remove the radiator cap by pushing down and turning counterclockwise.

3. The coolant level should be up to the base of the filler neck. Add coolant if it is low.

Pour the coolant slowly and carefully so you do not spill. Clean up any spill immediately; it could damage components in the engine compartment.

4. Put the radiator cap back on and tighten it.
5. Pour coolant into the reserve tank. Fill it to halfway between the MAX and MIN marks. Put the cap back on the reserve tank.

Do not add any rust inhibitors or other additives to your vehicle's cooling system. They may not be compatible with the coolant or engine components.

## Power Steering Fluid

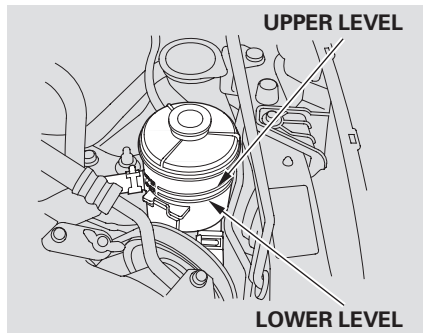

Check the level on the side of the reservoir when the engine is cold. The fluid should be between the UPPER LEVEL and LOWER LEVEL. If not add power steering fluid to the UPPER LEVEL mark.

Always use Honda Power Steering Fluid. You may use another power steering fluid as an emergency replacement, but have the power steering system flushed and refilled with Honda PSF as soon as possible.

A low power steering fluid level can indicate a leak in the system. Check the fluid level frequently, and have the system inspected as soon as possible.

**NOTICE:** *Turning the steering wheel to full left or right lock and holding it there can damage the power steering pump.*

# Automatic Transmission Fluid

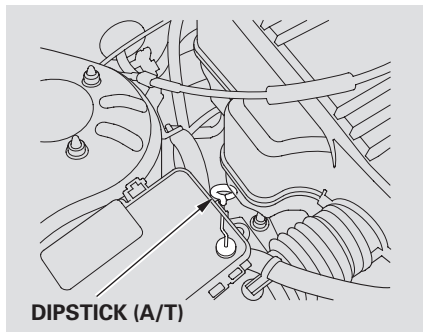

Check the fluid level with the engine at normal operating temperature.

1. Park the vehicle on level ground. Shut off the engine.

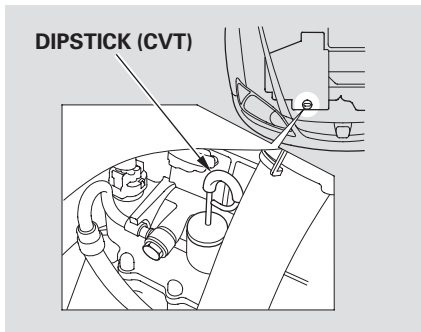

2. Remove the dipstick (yellow loop) from the transmission, and wipe it with a clean cloth.
3. Insert the dipstick all the way into the transmission.

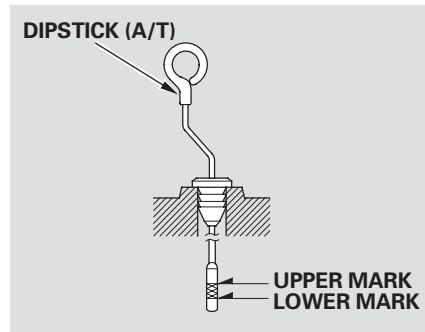

4. Remove the dipstick and check the fluid level. It should be between the upper and lower marks.

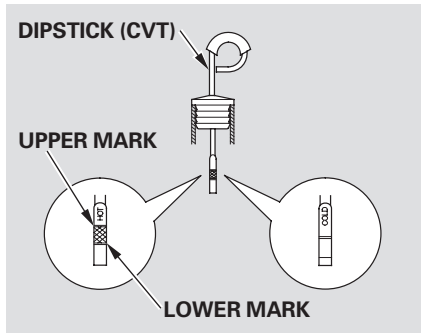

### *On CVT model*

Remove the dipstick and check the fluid level. There is a HOT side and a COLD side on the dipstick. It should be between the upper and lower marks on the HOT side.

5. If the level is below the lower mark, add fluid into the filler hole to bring it to the upper mark (On CVT model, the HOT side's upper mark).

Always use Honda ATF-Z1 (Automatic Transmission Fluid). If it's not available, you may use a DEXRON® III automatic transmission fluid as a temporary replacement. However, continued use can affect the shift quality. Have the transmission flushed and refilled with Honda ATF-Z1 as soon as it is convenient.

To thoroughly flush the transmission, the technician should drain and refill it with Honda ATF-Z1 (Automatic Transmission Fluid), then drive the vehicle for a short distance. Do this three times. Then drain and refill the transmission a final time.

6. Insert the dipstick all the way back into the transmission.

The transmission should be drained and refilled with new fluid according to the time and distance recommendations in the maintenance schedule.

If you are not sure how to add fluid, contact your Honda dealer.

# Manual Transmission Fluid, Timing Belt

## 5-speed Manual Transmission

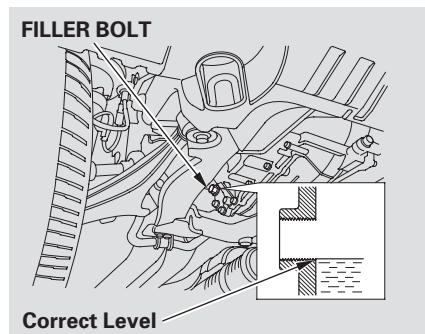

Check the fluid level with the transmission at normal operating temperature and the vehicle sitting on level ground. Remove the transmission filler bolt, and carefully feel inside the bolt hole with your finger. The fluid level should be up to the edge of the bolt hole. If it is not, add Honda Manual Transmission Fluid (MTF) until it starts to run out of the hole. Reinstall the filler bolt, and tighten it securely.

If Honda MTF is not available, you may use an SAE 10W-30 or 10W-40 viscosity motor oil with the API Certification seal that says "FOR GASOLINE ENGINES" as a temporary replacement. However, motor oil does not contain the proper additives, and continued use can cause stiffer shifting. Replace as soon as it is convenient.

The transmission should be drained and refilled with new fluid according to the time and distance recommendations in the maintenance schedule.

## Timing Belt

The timing belt should be replaced at the intervals shown in the maintenance schedule. Replace the belt at 60,000 miles (100,000 km) if you regularly drive your vehicle in one or more of these conditions:

- In very high temperatures (over 110°F, 43°C).
- In very low temperatures (under -20°F, -29°C).

## Brake Fluid

Check the fluid level in the brake fluid reservoir monthly. Replace it according to the maintenance schedule recommendations.

Always use Honda Heavy Duty Brake Fluid DOT 3. If it is not available, you should use only DOT 3 or DOT 4 fluid, from a sealed container, as a temporary replacement.

Using any non-Honda brake fluid can cause corrosion and decrease the life of the system. Have the brake system flushed and refilled with Honda Heavy Duty Brake Fluid DOT 3 as soon as possible.

Brake fluid marked DOT 5 is not compatible with your vehicle's braking system and can cause extensive damage.

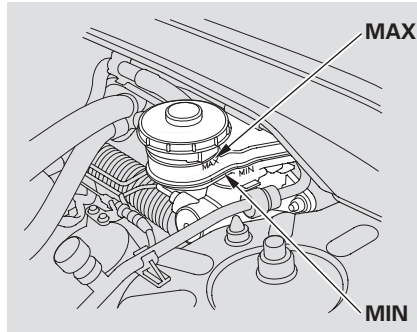

The fluid level should be between the MIN and MAX marks on the side of the reservoir. If the level is at or below the MIN mark, your brake system needs attention. Have the brake system inspected for leaks or worn brake pads.

## Clutch Fluid

*Manual Transmission only*

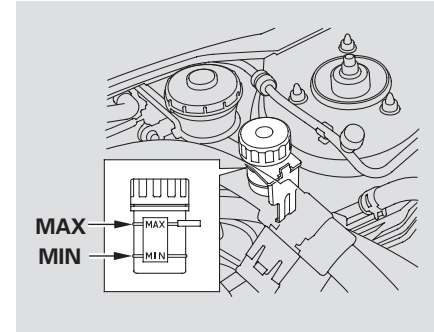

The fluid level should be between the MIN and MAX marks on the side of the reservoir. If it is not, add brake fluid to bring it up to that level. Use the same fluid specified for the brake system.

Low fluid level can indicate a leak in the clutch system. Have this system inspected as soon as possible.

# Lights

## Headlight Aiming

The headlights were properly aimed when your vehicle was new. If you regularly carry heavy items in the trunk, readjustment may be required. Adjustments should be performed by a Honda dealer or other qualified mechanic.

## Replacing a Headlight Bulb

Your vehicle has halogen headlight bulb. Handle it by its steel base and protect the glass from contact with your skin or hard objects. If you touch the glass, clean it with denatured alcohol and a clean cloth.

**NOTE:** Halogen headlight bulbs get very hot when lit. Oil, perspiration, or a scratch on the glass can cause the bulb to overheat and shatter.

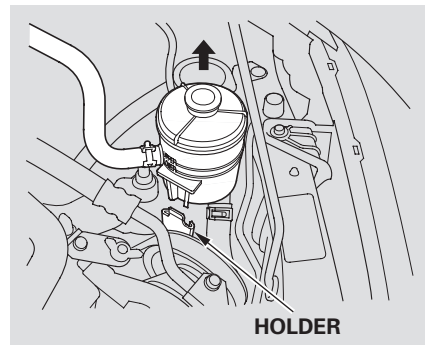

1. If you need to change the headlight bulb on the driver's side, remove the power steering reservoir tank by pulling it out of its holder.

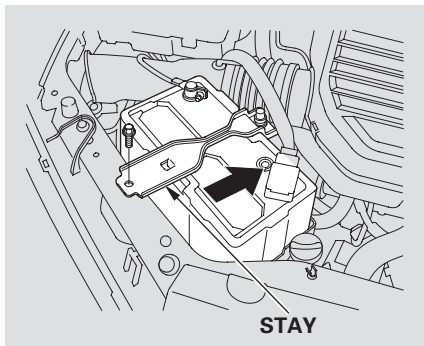

If you need to change a headlight bulb on the passenger's side, remove the bolt from the stay and push the battery toward windshield to obtain enough working space.

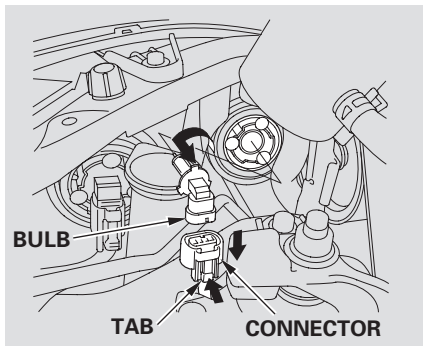

2. Remove the electrical connector from the bulb by pushing on the tab and pulling the connector down.
3. Remove the bulb by turning it one-quarter turn counterclockwise.

4. Insert the new bulb into the hole and turn it one-quarter turn clockwise to lock it in place.
5. Push the electrical connector back onto the bulb. Make sure it is on all the way.
6. Turn on the headlights to test the new bulb.
7. (Passenger's side)  
Put the battery back to its original position, reinstall the bolt in the stay and tighten it securely.
- (Driver's side)  
Reinstall the power steering reservoir.

*CONTINUED*



## Replacing the Front Side Marker/ Turn Signal and Parking Light Bulb

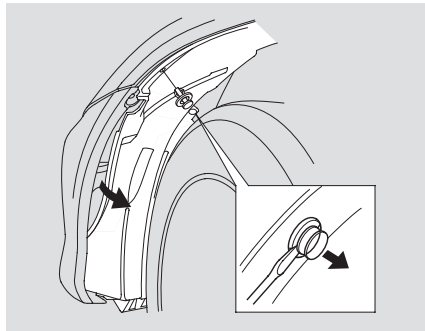

1. If you are changing the bulb on the driver's side, start the engine, turn the steering wheel all the way to the right, and turn off the engine. If you are changing the bulb on the passenger's side, turn the steering wheel to the left.

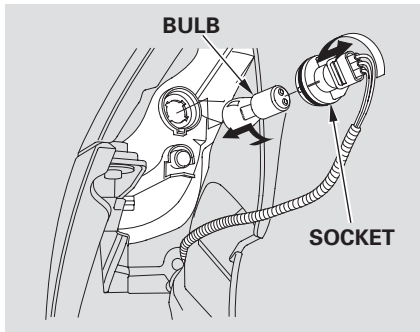

2. Use a flat-tipped screwdriver to remove the holding clip from the inner fender, and pull the inner fender cover back.
3. Remove the socket from the headlight assembly by turning it one-quarter turn counterclockwise.

4. Remove the bulb from the socket by pushing it in and turning the bulb counterclockwise until it unlocks.
5. Install the new bulb in the socket. Turn it clockwise to lock it in place.
6. Insert the socket back into the headlight assembly. Turn it clockwise to lock it in place.
7. Put the inner fender cover in place. Install the holding clip. Lock it in place by pushing on the center.

## Replacing Rear Bulbs

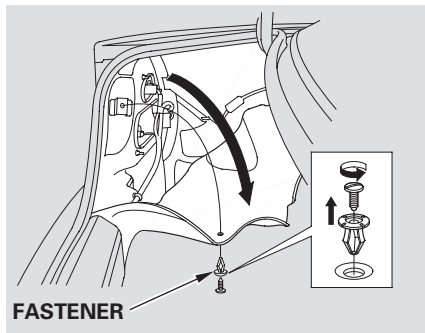

1. Open the trunk.

Remove the screw in the center of the fastener on the side of the trunk lining. Pull the lining back.

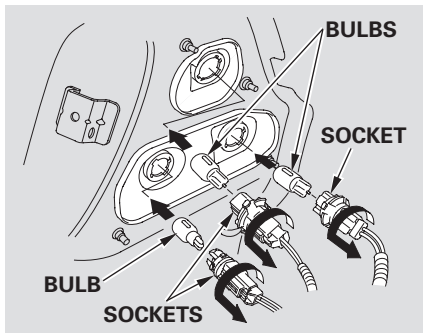

2. Determine which of the three bulbs is burned out: stop/taillight, back-up light or turn signal light.
3. Remove the socket by turning it one-quarter turn counterclockwise.

4. Pull the bulb straight out of its socket. Push the new bulb straight into the socket until it bottoms.
5. Reinstall the socket into the light assembly by turning it clockwise until it locks.
6. Test the lights to make sure the new bulb is working.
7. Reinstall the trunk lining. Make sure it is installed under the edge of the trunk seal.
8. Put the fastener into the hole on the side of the trunk lining. Reinstall the screw.

## Replacing a High-mount Brake Light Bulb

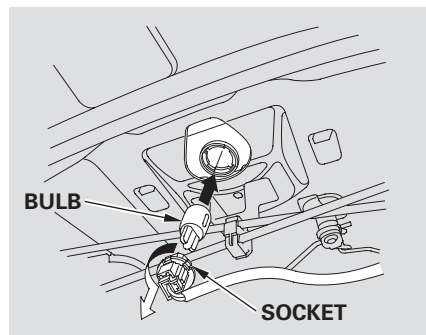

1. Open the trunk and remove the socket from the light assembly by turning it one-quarter turn counter-clockwise.
2. Pull the bulb straight out of its socket.  
Push the new bulb straight into the socket until it bottoms.

3. Reinstall the socket. Turn it clockwise until it locks. Make sure the new bulb is working.

## Seat Belts

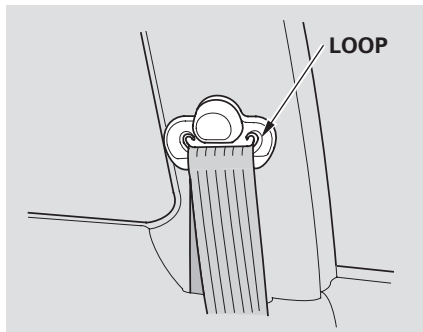

If your seat belts get dirty, use a soft brush with a mixture of mild soap and warm water to clean them. Do not use bleach, dye, or cleaning solvents. Let the belts air dry before you use the vehicle.

Dirt build-up in the loops of the seat belt anchors can cause the belts to retract slowly. Wipe the insides of the loops with a clean cloth dampened in mild soap and warm water or isopropyl alcohol.

## Floor Mats

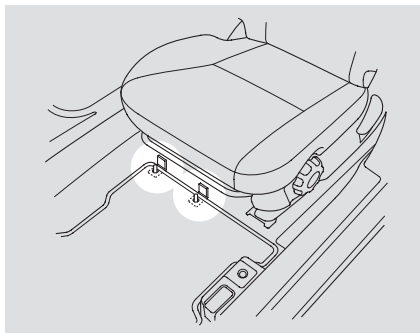

### *If equipped*

The driver's floor mat that came with your vehicle hooks over the floor mat anchor. This keeps the floor mat from sliding forward and possibly interfering with the pedals.

If you remove the driver's floor mat, make sure to re-anchor it when you put it back in your vehicle.

If you use a non-Honda floor mat, make sure it fits properly and that it can be used with the floor mat anchor. Do not put additional floor mats on top of the anchored mat.

## Dust and Pollen Filter

### *If equipped with A/C*

This filter removes the dust and pollen that is brought in from the outside through the heating and cooling system.

Have your Honda dealer replace this filter every 30,000 miles (48,000 km) under normal conditions. It should be replaced every 15,000 miles (24,000 km) if you drive primarily in urban areas that have high concentrations of soot in the air, or if the flow from the climate control system becomes less than usual.

# Wiper Blades

Check the condition of the wiper blades at least every six months. Replace them if you find signs of cracking in the rubber, areas that are getting hard, or if they leave streaks and unwiped areas when used.

1. Raise the wiper arm off the windshield.

## NOTICE

*Do not open the hood when the wiper arms are raised, or you will damage the hood and wiper arms.*

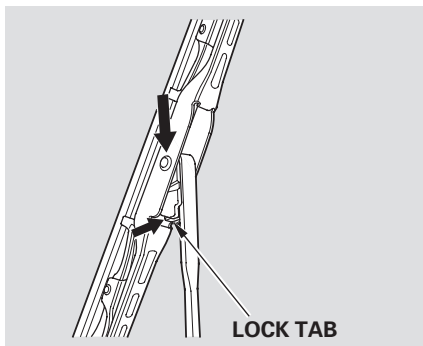

2. Disconnect the blade assembly from the wiper arm by pushing in the lock tab. Hold the lock tab in while you push the blade assembly toward the base of the arm.

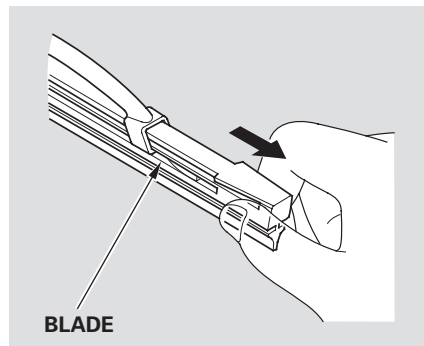

3. Remove the blade from its holder by grasping the tabbed end of the blade. Pull firmly until the tabs come out of the holder.

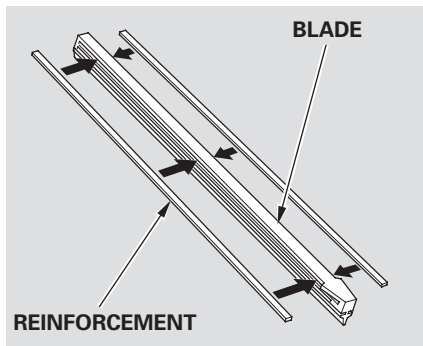

4. Examine the new wiper blades. If they have no plastic or metal reinforcement along the back edge, remove the metal reinforcement strips from the old wiper blade, and install them in the slots along the edge of the new blade.

5. Slide the new wiper blade into the holder until the tabs lock.
6. Slide the wiper blade assembly onto the wiper arm. Make sure it locks in place.
7. Lower the wiper arm down against the windshield.

# Tires

To safely operate your vehicle, your tires must be the proper type and size, in good condition with adequate tread, and correctly inflated.

The following pages give more detailed information on how to take care of your tires and what to do when they need to be replaced.

## **WARNING**

Using tires that are excessively worn or improperly inflated can cause a crash in which you can be seriously hurt or killed.

Follow all instructions in this owner's manual regarding tire inflation and maintenance.

## **Inflation**

Keeping the tires properly inflated provides the best combination of handling, tread life, and riding comfort.

- Underinflated tires wear unevenly, adversely affect handling and fuel economy, and are more likely to fail from being overheated.
- Overinflated tires can make your vehicle ride more harshly, are more prone to damage from road hazards, and wear unevenly.

We recommend that you visually check your tires every day. If you think a tire might be low, check it immediately with a tire gauge.

## ***Recommended Tire Pressures for Normal Driving***

The following chart shows the recommended cold tire pressures for most normal driving conditions and speed.

(U.S.: DX, HX, Canada:DX)

Tire Size	Cold Tire Pressure for Normal Driving
P185/70R14 87S	30 psi (210 kPa , 2.1 kgf/cm <sup>2</sup> )

(Canada: LX)

Tire Size	Cold Tire Pressure for Normal Driving
P185/65R15 86H	30 psi (210 kPa , 2.1 kgf/cm <sup>2</sup> )

(U.S.: LX, EX, Canada:Si)

Tire Size	Cold Tire Pressure for Normal Driving
P195/60R15 87H	30 psi (210 kPa , 2.1 kgf/cm <sup>2</sup> )

The compact spare tire pressure is:  
60 psi (420 kPa , 4.2 kgf/cm<sup>2</sup>)

**Tire Pressure Adjustment for High Speed Driving***U.S. DX, HX and Canadian DX models only*

Honda strongly recommends that you not drive faster than posted speed limits and conditions allow. If you decide it is safe to drive at high speeds, be sure to adjust the cold tire pressures as shown below. If you do not adjust the tire pressure, excessive heat can build up and cause sudden tire failure.

(U.S.: DX, HX, Canada:DX)

Tire Size	Cold Tire Pressure for speeds over 100 mph (160 km/h)
P185/70R14 87S	35 psi (240 kPa , 2.4 kgf/cm <sup>2</sup> )

When you return to normal speed driving, be sure to readjust the tire pressure for normal driving. You should wait until the tires are cold before adjusting the tire pressure.

*U.S. LX, EX and Canadian LX, Si models*  
Tire pressure for high speed driving is the same as for normal driving.

For convenience, the recommended tire sizes and cold air pressures are on a label on the driver's doorjamb.

For additional technical information, see page [210](#) .

Use a gauge to measure the air pressure at least once a month. Even tires that are in good condition may lose one to two psi (10 to 20 kPa, 0.1 to 0.2 kgf/cm<sup>2</sup>) per month. Remember to check the spare tire at the same time.

Check the pressure in the tires when they are cold. This means the vehicle has been parked for at least three hours, or driven less than 1 mile (1.6 km).

Add or release air, if needed, to match the recommended cold tire pressures on page [173](#) .

If you check the pressure when the tires are hot (driven for several miles), you will see readings 4 to 6 psi (30 to 40 kPa, 0.3 to 0.4 kgf/cm<sup>2</sup>) higher than the cold reading. This is normal; do not release air to match the cold pressure.

*CONTINUED*



# Tires

---

Tubeless tires have some ability to self-seal if they are punctured. You should look closely for punctures if a tire starts losing pressure.

You should get your own tire pressure gauge and use it whenever you check your tire pressures. This will make it easier for you to tell if a pressure loss is due to a tire problem and not due to a variation between gauges.

## **Tire Inspection**

Every time you check inflation, you should also examine the tires for damage, foreign objects, and wear. You should look for:

- Bumps or bulges in the tread or side of the tire. Replace the tire if you find either of these conditions.
- Cuts, splits, or cracks in the side of the tire. Replace the tire if you can see fabric or cord.
- Excessive tread wear. When you see a 1/2 inch (12.7 mm) wide band running across the tread, there is less than 1/16 inch (1.6 mm) of tread left on the tire. Replace the tire if you can see three or more tread wear indicators around it.

## Tire Maintenance

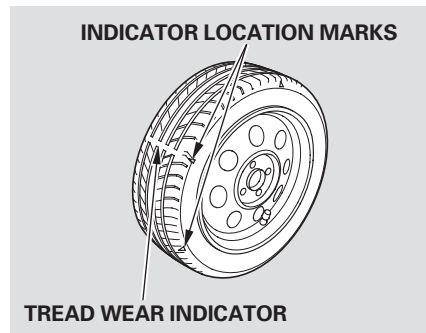

In addition to proper inflation, correct wheel alignment helps to decrease tire wear. If you find a tire is worn unevenly, have your dealer check the wheel alignment.

Have your dealer check the tires if you feel a consistent vibration while driving. A tire should always be rebalanced if it is removed from the wheel. When you have new tires installed, make sure they are balanced. This increases riding comfort and tire life. For best results, have the installer perform a dynamic balance.

**NOTICE:** *Improper wheel's weights can damage your vehicle's aluminum wheels. Use only genuine Honda wheel's weights for balancing.*

## Tire Rotation

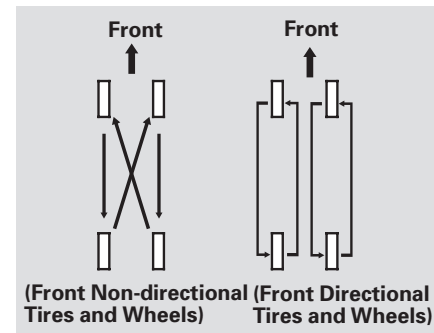

To help increase tire life and distribute wear more evenly, rotate the tires every 10,000 miles (16,000 km). Move the tires to the positions shown in the chart each time they are rotated. If you purchase directional tires, rotate only front-to-back.

# Tires

## Replacing Tires

Replace your tires with radial tires of the same size, load range, speed rating, and maximum cold tire pressure rating (as shown on the tire's sidewall). Mixing radial and bias-ply tires on your vehicle can reduce braking ability, traction, and steering accuracy. Using tires of a different size or construction can cause the ABS to work inconsistently.

It is best to replace all four tires at the same time. If that is not possible or necessary, replace the two front tires or two rear tires as a pair. Replacing just one tire can seriously affect your vehicle's handling.

If you ever replace a wheel, make sure that the wheel's specifications match those of the original wheels.

## WARNING

Installing improper tires on your vehicle can affect handling and stability. This can cause a crash in which you can be seriously hurt or killed.

Always use the size and type of tires recommended in this owner's manual.

## Wheel and Tire Specifications

### Wheels:

(U.S.: DX, Canada: DX)

14 x 5 1/2 JJ

(U.S.: LX, Canada: LX)

15 x 6 JJ

(U.S.: EX, Canada: Si)

15 x 6 JJ(Aluminum Wheel)

(U.S.: HX)

14 x 5 1/2 JJ(Aluminum Wheel)

### Tires:

(U.S.: DX, HX, Canada: DX)

P185/70R14 87S

(Canada: LX)

P185/65R15 86H

(U.S.: LX, EX, Canada: Si)

P195/60R15 87H

See page [210](#) for DOT tire quality grading information, and page [211](#) for tire size explanation.

## Winter Driving

Tires marked “M + S” or “All Season” on the sidewall have an all-weather tread design suitable for most winter driving conditions.

For the best performance in snowy or icy conditions, you should install snow tires or tire chains. They may be required by local laws under certain conditions.

## Snow Tires

If you mount snow tires on your Honda, make sure they are radial tires of the same size and load range as original tires. Mount snow tires on all four wheels. The traction provided by snow tires on dry roads may be lower than your original tires. Check with the tire dealer for maximum speed recommendations.

## Tire Chains

Because your Honda has limited tire clearance, mount only SAE Class “S” cable-type traction devices, with rubber chain tensioners on the front tires. Use traction devices only when required by driving conditions or local laws. Make sure they are the correct size for your tires. Make link-type “chains” should not be used.

When installing cables, follow the manufacturer’s instructions, and mount them as tight as you can. Make sure they are not contacting the brake lines or suspension. Drive slowly with them installed. If you hear them coming into contact with the body or chassis, stop and investigate. Remove them as soon as you begin driving on cleared roads.

**NOTICE:** *Traction devices that are the wrong size or improperly installed can damage your vehicle’s brake lines, suspension, body, and wheels. Stop driving if they are hitting any part of the vehicle.*

## Checking the Battery

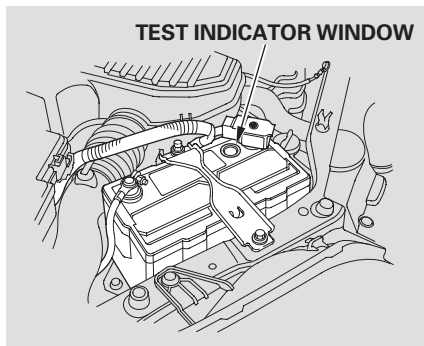

Check the condition of the battery monthly by looking at the test indicator window. The label on the battery explains the test indicator's colors.

Check the terminals for corrosion (a white or yellowish powder). To remove it, cover the terminals with a solution of baking soda and water. It will bubble up and turn brown. When this stops, wash it off with plain water. Dry off the battery with a cloth or paper towel. Coat the terminals with grease to help prevent further corrosion.

If additional battery maintenance is needed, see your Honda dealer or a qualified technician.

**WARNING:** Battery posts, terminals, and related accessories contain lead and lead compounds. **Wash your hands after handling.**

If you need to connect the battery to a charger, disconnect both cables to prevent damaging your vehicle's electrical system. Always disconnect the negative (–) cable first, and reconnect it last.

### **WARNING**

The battery gives off explosive hydrogen gas during normal operation.

A spark or flame can cause the battery to explode with enough force to kill or seriously hurt you.

Wear protective clothing and a face shield, or have a skilled mechanic do the battery maintenance.

If you need to park your vehicle for an extended period (more than one month), there are several things you should do to prepare it for storage. Proper preparation helps prevent deterioration and makes it easier to get your vehicle back on the road. If possible, store your vehicle indoors.

- Fill the fuel tank.
- Change the engine oil and filter.
- Wash and dry the exterior completely.
- Clean the interior. Make sure the carpeting, floor mats, etc. are completely dry.
- Leave the parking brake off. Put the transmission in Reverse (5-speed manual) or Park (automatic).

- Block the rear wheels.
- If the vehicle is to be stored for a longer period, it should be supported on jackstands so the tires are off the ground.
- Leave one window open slightly (if the car is being stored indoors).
- Disconnect the battery.
- Support the front wiper blade arms with a folded towel or rag so they do not touch the windshield.
- To minimize sticking, apply a silicone spray lubricant to all door and trunk seals. Also, apply a vehicle body wax to the painted surfaces that mate with the door and trunk seals.

- Cover the vehicle with a “breathable” cover, one made from a porous material such as cotton. Non-porous materials, such as plastic sheeting, trap moisture, which can damage the paint.
- If possible, run the engine for a while periodically until it reaches full operating temperature (the cooling fan cycle on and off twice). Preferably once a month.

If you store your vehicle for 12 months or longer, have your Honda dealer perform the inspections called for in the 24 months/30,000 miles maintenance schedule (Normal Conditions) as soon as you take it out of storage (see page 145). The replacements called for in the maintenance schedule are not needed unless the vehicle has actually reached that time or mileage.



This section covers the more common problems that motorists experience with their vehicles. It gives you information about how to safely evaluate the problem and what to do to correct it. If the problem has stranded you on the side of the road, you may be able to get going again. If not, you will also find instructions on getting your vehicle towed.

Compact Spare Tire.....	182
Changing a Flat Tire .....	183
If the Engine Won't Start.....	189
Jump Starting .....	191
If the Engine Overheats .....	192
Low Oil Pressure Indicator .....	195
Charging System Indicator.....	195
Malfunction Indicator Lamp .....	196
Brake System Indicator .....	197
Closing the Moonroof .....	198
Fuses .....	199
Fuse Locations.....	201
Emergency Towing .....	203



## Compact Spare Tire

Use the compact spare tire as a temporary replacement only. Get your regular tire repaired or replaced and put it back on your vehicle as soon as you can.

Check the inflation pressure of the compact spare tire every time you check the other tires. It should be inflated to:  
60 psi (420 kPa , 4.2 kgf/cm<sup>2</sup>)

Follow these precautions whenever you are using the compact spare tire:

- Never exceed 50 mph (80 km/h) under any circumstances.
- This tire gives a harsher ride and less traction on some road surfaces than the regular tire. Use greater caution while driving on this tire.
- Do not mount snow chains on it.
- Do not use your compact spare tire on another vehicle unless it is the same make and model.

INDICATOR LOCATION MARK

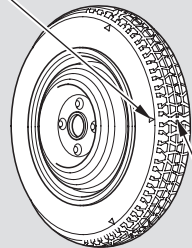

TREAD WEAR INDICATOR

Replace the tire when you can see the tread wear indicator bars. The replacement should be the same size and design tire, mounted on the same wheel. The spare tire is not designed to be mounted on a regular wheel, and the spare wheel is not designed for mounting a regular tire.

If you have a flat tire while driving, stop in a safe place to change it. Drive slowly along the shoulder until you get to an exit or an area that is far away from the traffic lanes.

## **⚠ WARNING**

The vehicle can easily roll off the jack, seriously injuring anyone underneath.

Follow the directions for changing a tire exactly, and never get under the vehicle when it is supported only by the jack.

1. Park the vehicle on firm, level and non-slippery ground. Put the transmission in Park (automatic) or Reverse (manual). Apply the parking brake.
2. Turn on the hazard warning lights, and turn the ignition switch to LOCK (0). Have all the passengers get out of the vehicle while you change the tire.

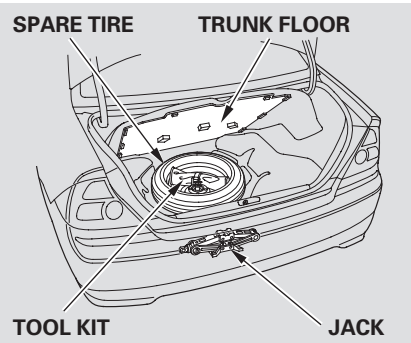

3. Open the trunk. Raise the trunk floor mat and the trunk floor by lifting up on the back edge.
4. Take the tool kit out of the trunk.
5. Unscrew the wing bolt and take the spare tire out of its well.

*CONTINUED*

# Changing a Flat Tire

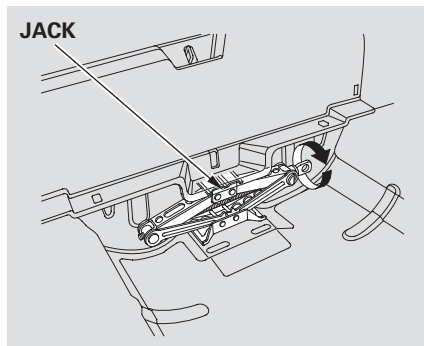

6. Turn the jack's end counterclockwise to loosen it, then remove the jack.

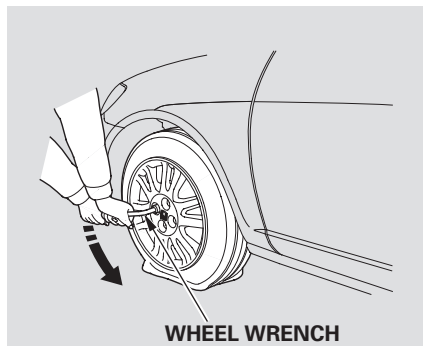

7. Loosen each wheel nut 1/2 turn with the wheel wrench.

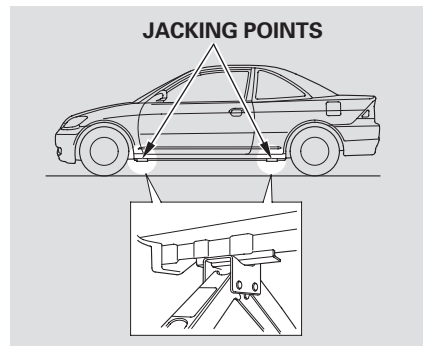

8. Place the jack under the jacking point. Turn the end bracket clockwise until the top of the jack contacts the jacking point. Make sure the jacking point tab is resting in the jack notch.

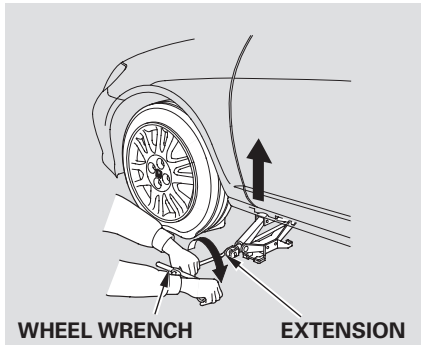

9. Use the extension and wheel wrench as shown to raise the vehicle until the flat tire is off the ground.

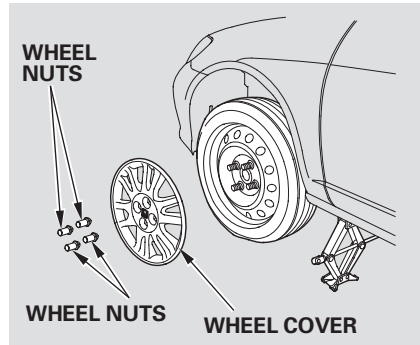

10. *DX and LX models:*  
Remove the wheel nuts and wheel cover. The wheel nuts will be very hot if you were recently driving. The wheel cover cannot be removed without first removing the wheel nuts. Do not attempt to forcibly pry the wheel cover off with a screwdriver or other tool.

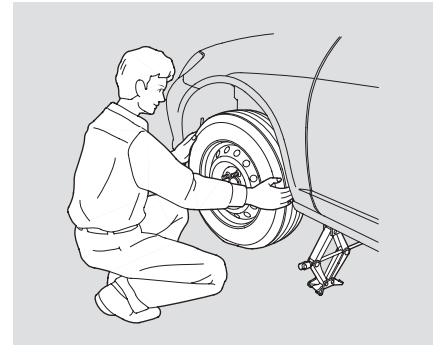

11. Remove the flat tire. Place the flat tire on the ground with the outside surface facing up.

*CONTINUED*

## Changing a Flat Tire

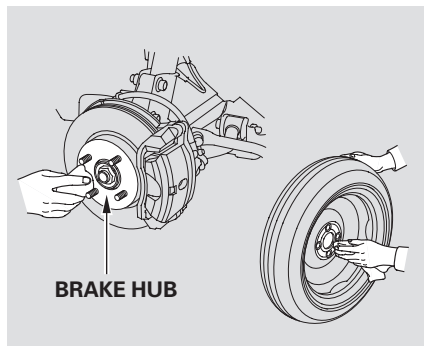

12. Before mounting the spare tire, wipe any dirt off the mounting surface of the wheel and hub with a clean cloth. Wipe the hub carefully; it may be hot from driving.

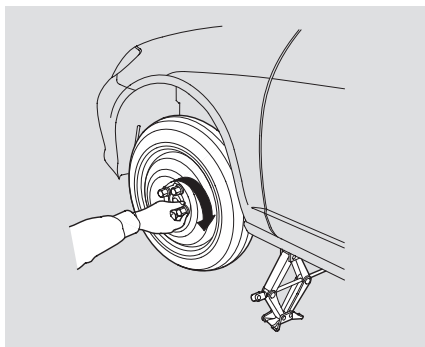

13. Put on the spare tire. Put the wheel nuts back on finger-tight, then tighten them in a crisscross pattern with the wheel wrench until the wheel is firmly against the hub. Do not try to tighten them fully.

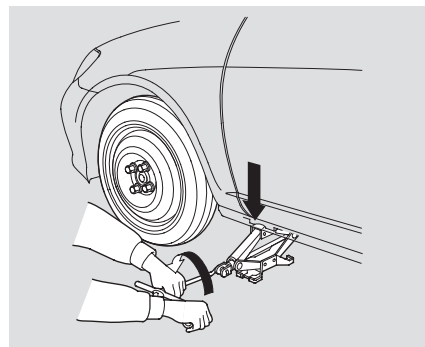

14. Lower the vehicle to the ground and remove the jack.

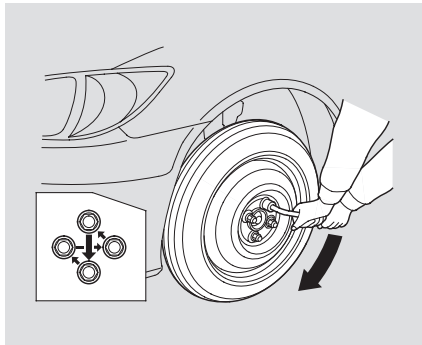

15. Tighten the wheel nuts securely in the same crisscross pattern. Have the wheel nut torque checked at the nearest automotive service facility.

Tighten the wheel nuts to:  
80 lbf·ft (108 N·m , 11 kgf·m)

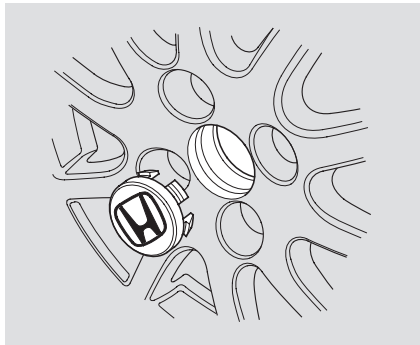

16. *On HX and EX models in the U.S., Si model in Canada*

Remove the center cap before storing the flat tire in the trunk well.

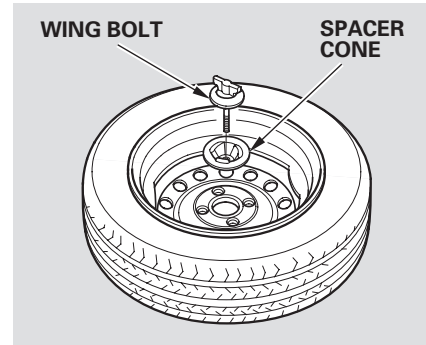

17. Place the flat tire face down in the spare tire well.

18. Remove the spacer cone from the wing bolt, turn it over, and put it back on the bolt.

19. Secure the flat tire by screwing the wing bolt back into its hole.

*CONTINUED*

## Changing a Flat Tire

---

20. Store the jack in the trunk with the end bracket on the left side. Turn the jack's end bracket to lock it in place. Store the tool kit.

### **WARNING**

Loose items can fly around the interior in a crash and could seriously injure the occupants.

Store the wheel, jack, and tools securely before driving.

21. Store the wheel cover or center cap in the trunk. Make sure it does not get scratched or damaged.
22. Lower the trunk floor, then close the trunk lid.

Diagnosing why your engine won't start falls into two areas, depending on what you hear when you turn the key to START (III):

- You hear nothing, or almost nothing. The engine's starter motor does not operate at all, or operates very slowly.
- You can hear the starter motor operating normally, or the starter motor sounds like it is spinning faster than normal, but the engine does not start up and run.

### **Nothing Happens or the Starter Motor Operates Very Slowly**

When you turn the ignition switch to START (III), you do not hear the normal noise of the engine trying to start. You may hear a clicking sound or series of clicks, or nothing at all. Check these things:

- Check the transmission interlock. If you have a manual transmission, the clutch pedal must be pushed all the way to the floor or the starter will not operate. With an automatic transmission, it must be in Park or Neutral.
- Turn the ignition switch to ON (II). Turn on the headlights and check their brightness. If the headlights are very dim or don't light at all, the battery is discharged. See **Jump Starting** on page [191](#).

- Turn the ignition switch to START (III). If the headlights do not dim, check the condition of the fuses. If the fuses are OK, there is probably something wrong with the electrical circuit for the ignition switch or starter motor. You will need a qualified technician to determine the problem (see **Emergency Towing** on page [203](#)).

If the headlights dim noticeably or go out when you try to start the engine, either the battery is discharged or the connections are corroded. Check the condition of the battery and terminal connections (see page [178](#)). You can then try jump starting the vehicle from a booster battery (see page [191](#)).



# If the Engine Won't Start

---

## The Starter Operates Normally

In this case, the starter motor's speed sounds normal, or even faster than normal, when you turn the ignition switch to START (III), but the engine does not run.

- Are you using the proper starting procedure? Refer to **Starting the Engine** on page [127](#).
- Are you using a properly coded key? An improperly coded key will cause the immobilizer system indicator in the instrument panel to blink rapidly (see page [70](#)).

- Do you have fuel? Check the fuel gauge; the low fuel indicator may not be working.
- There may be an electrical problem, such as no power to the fuel pump. Check all the fuses (see page [199](#)).

If you find nothing wrong, you will need a qualified technician to find the problem. See **Emergency Towing** on page [203](#).

Although this seems like a simple procedure, you should take several precautions.

## **⚠ WARNING**

A battery can explode if you do not follow the correct procedure, seriously injuring anyone nearby.

Keep all sparks, open flames, and smoking materials away from the battery.

You cannot start a Honda with an automatic transmission by pushing or pulling it.

### ***To Jump Start Your Vehicle:***

1. Open the hood and check the physical condition of the battery. In very cold weather, check the condition of the electrolyte. If it seems slushy or like ice, do not try jump starting until it thaws.

**NOTICE:** *If a battery sits in extreme cold, the electrolyte inside can freeze. Attempting to jump start with a frozen battery can cause it to rupture.*

2. Turn off all the electrical accessories: heater, A/C, climate control, stereo system, lights, etc. Put the transmission in Neutral or Park, and set the parking brake.
3. Connect one jumper cable to the positive (+) terminal on your battery. Connect the other end to the positive (+) terminal on the booster battery.

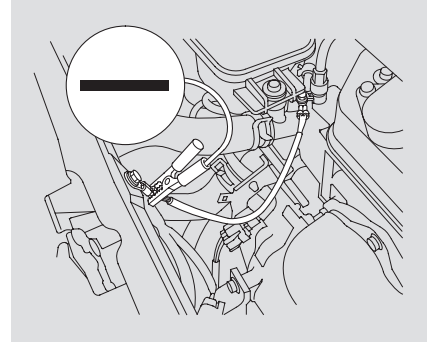

4. Connect the second jumper cable to the negative (-) terminal on the booster battery. Connect the other end to the grounding strap as shown. Do not connect this jumper cable to any other part of the engine.
5. If the booster battery is in another vehicle, have an assistant start that vehicle and run it at a fast idle.

*CONTINUED*

## Jump Starting, If the Engine Overheats

---

6. Start your vehicle. If the starter motor still operates slowly, check the jumper cable connections to make sure they have good metal-to-metal contact.
7. Once your vehicle is running, disconnect the negative cable from your vehicle, then from the booster battery. Disconnect the positive cable from your vehicle, then from the booster battery.

Keep the ends of the jumper cables away from each other and any metal on the vehicle until all are disconnected. Otherwise, you may cause an electrical short.

### **If the Engine Overheats**

The pointer of your vehicle's temperature gauge should stay in the midrange. If it climbs to the red mark, you should determine the reason (hot day, driving up a steep hill, etc.).

If your vehicle overheats, you should take immediate action. The only indication may be the temperature gauge climbing to or above the red mark. Or you may see steam or spray coming from under the hood.

**NOTICE:** *Driving with the temperature gauge pointer at the red mark can cause serious damage to your engine.*

### **WARNING**

Steam and spray from an overheated engine can seriously scald you.

Do not open the hood if steam is coming out.

1. Safely pull to the side of the road. Put the transmission in Neutral or Park, and set the parking brake. Turn off all the accessories, and turn on the hazard indicator.
2. If you see steam and/or spray coming from under the hood, turn off the engine. Wait until you see no more signs of steam or spray, then open the hood.
3. If you do not see steam or spray, leave the engine running and watch the temperature gauge. If the high heat is due to overloading, the engine should start to cool down almost immediately. If it does, wait until the temperature gauge comes down to the midpoint, then continue driving.
4. If the temperature gauge stays at the red mark, turn off the engine.
5. Look for any obvious coolant leaks, such as a split radiator hose. Everything is still extremely hot, so use caution. If you find a leak, it must be repaired before you continue driving (see **Emergency Towing** on page [203](#) ).
6. If you don't find an obvious leak, check the coolant level in the radiator reserve tank. Add coolant if the level is below the MIN mark.

*CONTINUED*

## If the Engine Overheats

---

7. If there was no coolant in the reserve tank, you may need to add coolant to the radiator. Let the engine cool down until the pointer reaches the middle of the temperature gauge, or lower, before checking the radiator.

### **WARNING**

Removing the radiator cap while the engine is hot can cause the coolant to spray out, seriously scalding you.

Always let the engine and radiator cool down before removing the radiator cap.

8. Using gloves or large heavy cloth, turn the radiator cap counterclockwise without pushing down to the first stop. After the pressure releases, push down on the cap, and turn it until it comes off.

9. Start the engine, and set the temperature control dial to maximum. Add coolant to the radiator up to the base of the filler neck. If you do not have the proper coolant mixture available, you can add plain water. Remember to have the cooling system drained and refilled with the proper mixture as soon as you can.

10. Put the radiator cap back on tightly. Run the engine and watch the temperature gauge. If it goes back to the red mark, the engine needs repair (see **Emergency Towing** on page [203](#)).

11. If the temperature stays normal, check the coolant level in the radiator reserve tank. If it has gone down, add coolant to the MAX mark. Put the cap back on tightly.

## Low Oil Pressure Indicator



This indicator should never come on when the engine is running. If it starts flashing or stays on, the oil pressure has dropped very low or lost pressure. Serious engine damage is possible and you should take immediate action.

**NOTICE:** *Running the engine with low oil pressure can cause serious mechanical damage almost immediately. Turn off the engine as soon as you can safely get the car stopped.*

1. Safely pull off the road, and shut off the engine. Turn on the hazard warning indicators.
2. Let the vehicle sit for a minute. Open the hood, and check the oil level (see page 117). An engine very low on oil can lose pressure during cornering and other driving maneuvers.
3. If necessary, add oil to bring the level back to the full mark on the dipstick (see page 152).
4. Start the engine, and watch the oil pressure indicator. If it does not go out within 10 seconds, turn off the engine. There is a mechanical problem that needs to be repaired before you can continue driving (see **Emergency Towing** on page 203).

## Charging System Indicator



If the charging system indicator comes on brightly when the engine is running, the battery is not being charged.

Immediately turn off all electrical accessories. Try not to use other electrically operated controls such as the power windows. Keep the engine running; starting the engine will discharge the battery rapidly.

Go to a service station or garage where you can get technical assistance.

# Malfunction Indicator Lamp

---



If the indicator comes on while driving, it means one of the engine's emission control systems may have a problem. Even though you may feel no difference in your vehicle's performance, it can reduce your fuel economy and cause increased emissions. Continued operation may cause serious damage.

If you have recently refueled your vehicle, the indicator coming on could be a loose or missing fuel fill cap. Tighten the cap until it clicks at least three times. Tightening the cap will not turn the indicator off immediately; it takes at least three days of normal driving.

If the indicator remains on, or the fuel cap was not loose or missing, have your vehicle checked by the dealer as soon as possible.

**NOTICE:** *If you keep driving with the Malfunction Indicator Lamp on, you can damage your vehicle's emission controls and the engine. Those repairs may not be covered by your vehicle's warranties.*

## Readiness Codes

Your vehicle has certain "readiness codes" that are part of the on-board diagnostics for the emissions systems. In some states, part of the emissions testing is to make sure these codes are set. If they are not set, the test cannot be completed.

If your vehicle battery has been disconnected or gone dead, these codes are erased. It takes at least three days of driving under various conditions to set the codes again.

To check if they are set, turn the ignition to ON (II), without starting the engine. The Malfunction Indicator Lamp will come on for 20 seconds. If it then goes off, the readiness codes are set. If it blinks 5 times, the readiness codes are not set. If possible, do not take your vehicle for a state emissions test until the readiness codes are set. Refer to State Emissions Testing for more information (see page [215](#)).



The brake system indicator normally comes on when you turn the ignition switch ON (II) and as a reminder to check the parking brake. It will stay lit if you do not fully release the parking brake.

If the brake system indicator comes on while driving, the brake fluid level is probably low. Press lightly on the brake pedal to see if it feels normal. If it does, check the brake fluid level the next time you stop at a service station (see page [163](#) ).

If the fluid level is low, take your vehicle to the dealer and have the brake system inspected for leaks or worn brake pads.

However, if the brake pedal does not feel normal, you should take immediate action. A problem in one part of the system's dual circuit design will still give you braking at two wheels. You will feel the brake pedal go down much farther before the vehicle begins to slow down and you will have to press harder on the pedal.

Slow down by shifting to a lower gear, and pull to the side of the road when it is safe. Because of the long distance needed to stop, it is hazardous to drive the vehicle. You should have it towed and repaired as soon as possible (see **Emergency Towing** on page [203](#) ).

If you must drive the vehicle a short distance in this condition, drive slowly and carefully.



# Closing the Moonroof

*On EX model in the U.S., and Si model in Canada*

If the electric motor will not close the moonroof, do the following:

1. Check the fuse for the moonroof motor (see page 202 ). If the fuse is blown, replace it with one of the same or lower rating.
2. Try closing the moonroof. If the new fuse blows immediately or the moonroof motor still does not operate, you can close the moonroof manually.
3. Get the moonroof wrench out of the tool kit in the trunk.

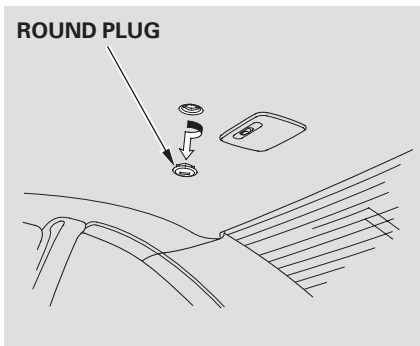

4. Use a screwdriver or coin to remove the round plug in the center of the headliner.

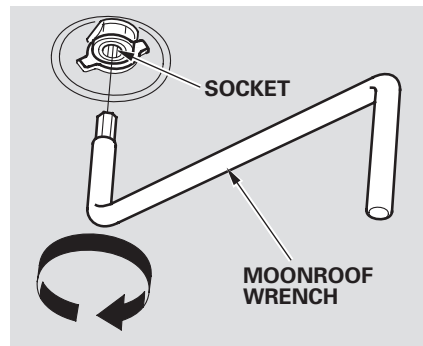

5. Insert the moonroof wrench into the socket behind this plug. Turn the wrench until the moonroof is fully closed.
6. Remove the wrench. Reinstall the round plug.

## INTERIOR

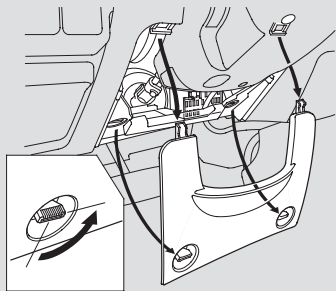

The vehicle's fuses are located in two fuse boxes. The interior fuse box is located underneath the steering column. To open it, turn the knobs as shown.

The primary under-hood fuse box is located on the passenger's side next to the battery.

## UNDER-HOOD

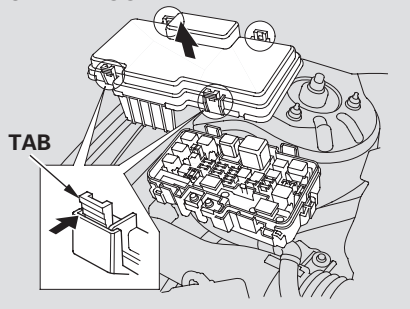

## Checking and Replacing Fuses

If something electrical in your vehicle stops working, check for there is a blown fuse first.

Determine from the chart on pages [201](#) and [202](#) or the diagram on the fuse box lid, which fuses control that device. Check those fuses first, but check all the fuses before deciding that a blown fuse is the cause.

Replace any blown fuses, and check if the device works.

## FUSE

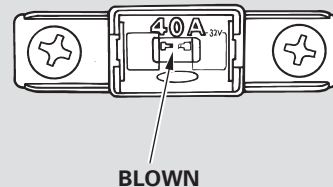

1. Turn the ignition switch to LOCK (0). Make sure the headlights and all other accessories are off.
2. Remove the cover from the fuse box.
3. Check each of the large fuses in the under-hood fuse box by looking through the top at the wire inside. Remove the screw with a Phillips-head screwdriver.

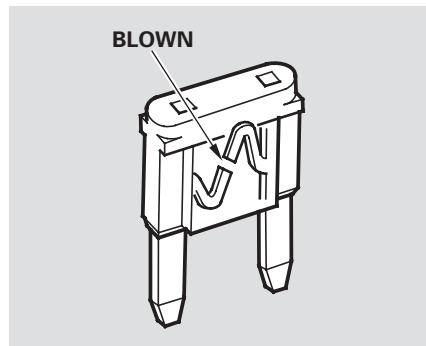

4. Check the smaller fuses in the under-hood fuse box and all the fuses in the interior fuse box by pulling out each fuse with the fuse puller provided in the under-hood fuse box.
5. Look for a burned wire inside the fuse. If it is burned, replace it with one of the spare fuses of the same rating or lower.

If you cannot drive the vehicle without fixing the problem, and you do not have a spare fuse, take a fuse of the same rating or a lower rating from one of the other circuits. Make sure you can do without that circuit temporarily (such as the accessory power socket or radio).

If you replace the blown fuse with a spare fuse that has a lower rating, it might blow out again. This does not indicate anything wrong. Replace the fuse with one of the correct rating as soon as you can.

**NOTICE:** *Replacing a fuse with one that has a higher rating greatly increases the chances of damaging the electrical system. If you do not have a replacement fuse with the proper rating for the circuit, install one with a lower rating.*

6. If the replacement fuse of the same rating blows in a short time, there is probably a serious electrical problem in your vehicle. Leave the blown fuse in that circuit, and have your vehicle checked by a qualified mechanic.

*Standard for HX, LX and EX models in the U.S., and LX and Si models in Canada*

If the radio fuse is removed, the audio system will disable itself. The next time you turn on the radio you will see "CODE" in the frequency display. Use the preset buttons to enter the five-digit code (see page 107).

*On all models*

When the audio system is disabled, the clock setting in the audio system will be canceled. You will need to reset the clock according to the instructions in the audio system section on this owner's manual.

## UNDER-HOOD FUSE BOX

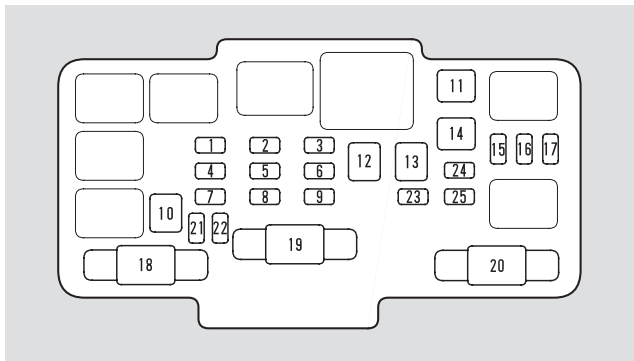

No.	Amps.	Circuits Protected
1	20 A	Condenser Fan
2	15 A	Small Light
3	7.5 A	Interior Light
4	20 A	Cooling Fan
5	10 A	Hazard, Turn Signals
6	15 A	FI ECU
7	15 A	Horn, Brake Light
8	20 A	ABS F/S
9	10 A	Back Up
10	40 A	ABS Motor
11	40 A	Rear Defroster
12	40 A	Heater Motor
13	40 A	Power Window
14	40 A	Option
15	20 A	Left Headlight
16	20 A	Door Lock
17	20 A	Right Headlight
18	—	Not Used
19	80 A	Battery
20	40 A	Ignition 1
21 - 25	7.5 A - 30 A	Spare Fuses

CONTINUED

# Fuse Locations

## INTERIOR FUSE BOX

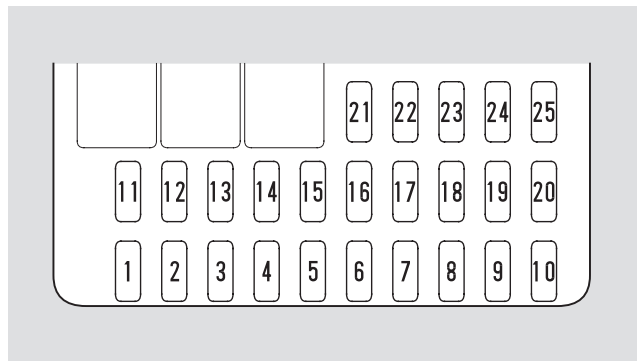

No.	Amps.	Circuits Protected
1	15 A	Ignition Coil
2	20 A	LAF Heater
3	10 A	Daytime Running Lights*
4	10 A	Alternator
5	—	Not Used

No.	Amps.	Circuits Protected
6	7.5 A	Power Window Relay
7	20 A	Moonroof
8	7.5 A	Accessory, Radio
9	10 A	SIDE SRS
10	7.5 A	Meter
11	7.5 A	ABS
12	7.5 A	Daytime Running Lights*
13	10 A	SRS
14	10 A	Power Mirrors
15	10 A	(Security)
16	—	Not Used
17	15 A	Fuel Pump
18	15 A	Accessory Power Socket
19	7.5 A	Turn Signal Lights
20	20 A	Front Wipers
21	—	Not Used
22	20 A	Front Right Power Window
23	20 A	Front Left Power Window
24	—	Not Used
25	—	Not Used

\* : On Canadian models

If your vehicle needs to be towed, call a professional towing service or organization. Never tow your vehicle with just a rope or chain. It is very dangerous.

There are three popular types of professional towing equipment.

**Flat-bed Equipment** — The operator loads your vehicle on the back of a truck. **This is the best way to transport your Honda.**

**Wheel-lift Equipment** — The tow truck uses two pivoting arms that go under the tires (front or rear) and lift them off the ground. The other two tires remain on the ground. **This is an acceptable way to tow your Honda.**

**Sling-type Equipment** — The tow truck uses metal cables with hooks on the ends. These hooks go around parts of the frame or suspension and the cables lift that end of the vehicle off the ground. Your vehicle's suspension and body can be seriously damaged. **This method of towing is unacceptable.**

If your Honda cannot be transported by flat-bed, it should be towed by wheel-lift equipment with the front wheels off the ground. If, due to damage, your vehicle must be towed with the front wheels on the ground, do the following:

*5-speed Manual Transmission and Continuously Variable Transmission (CVT)*

- Release the parking brake.
- Shift the transmission to Neutral.

*Automatic Transmission:*

- Release the parking brake.
- Start the engine.
- Shift to D, then to N.
- Turn off the engine.

**NOTICE:** *Improper towing preparation will damage the transmission. Follow the above procedure exactly. If you cannot shift the transmission or start the engine (automatic transmission), your vehicle must be transported with the front wheels off the ground.*

CONTINUED

## Emergency Towing

---

With the front wheels on the ground, it is best to tow the vehicle no farther than 50 miles (80 km), and keep the speed below 35 mph (55 km/h).

If your vehicle is equipped with a front spoiler, remove it before towing so it is not damaged.

If you decide to tow your vehicle with all four wheels on the ground, make sure you use a properly-designed and attached tow bar. Prepare the vehicle for towing as described above, and leave the ignition switch in Accessory (I) so the steering wheel does not lock. Make sure the radio and any items plugged into the accessory power socket are turned off so they do not run down the battery.

**NOTICE:** *The steering system can be damaged if the steering wheel is locked. Leave the ignition switch in Accessory (I), and make sure the steering wheel turns freely before you begin towing.*

**NOTICE:** *Trying to lift or tow your vehicle by the bumpers will cause serious damage. The bumpers are not designed to support the vehicle's weight.*

The diagrams in this section give you the dimensions and capacities of your Honda, and the locations of the identification numbers. It also includes information you should know about your vehicle's tires and emissions control systems.

Identification Numbers .....	206	Emissions Controls.....	212
Specifications .....	208	The Clean Air Act.....	212
DOT Tire Quality Grading		Crankcase Emissions Control	
(U.S. Vehicles) .....	210	System.....	212
Treadwear .....	210	Evaporative Emissions Control	
Traction.....	210	System.....	212
Temperature .....	211	Onboard Refueling Vapor	
Tire Labeling.....	211	Recovery .....	212
		Exhaust Emissions Controls....	213
		PGM-FI System .....	213
		Ignition Timing Control	
		System.....	213
		Three Way Catalytic	
		Converter.....	213
		Replacement Parts.....	213
		Three Way Catalytic Converter...	214
		State Emissions Testing .....	215
		Testing of Readiness Codes.....	215



## Identification Numbers

Your vehicle has several identifying numbers located in various places.

The Vehicle Identification Number (VIN) is the 17-digit number your Honda dealer uses to register your vehicle for warranty purposes. It is also necessary for licensing and insuring your vehicle. The easiest place to find the VIN is on a plate fastened to the top of the dashboard. You can see it by looking through the windshield on the driver's side. It is also on the Certification label attached to the driver's doorjamb, and is stamped on the engine compartment bulkhead. The VIN is also provided in bar code on the Certification label.

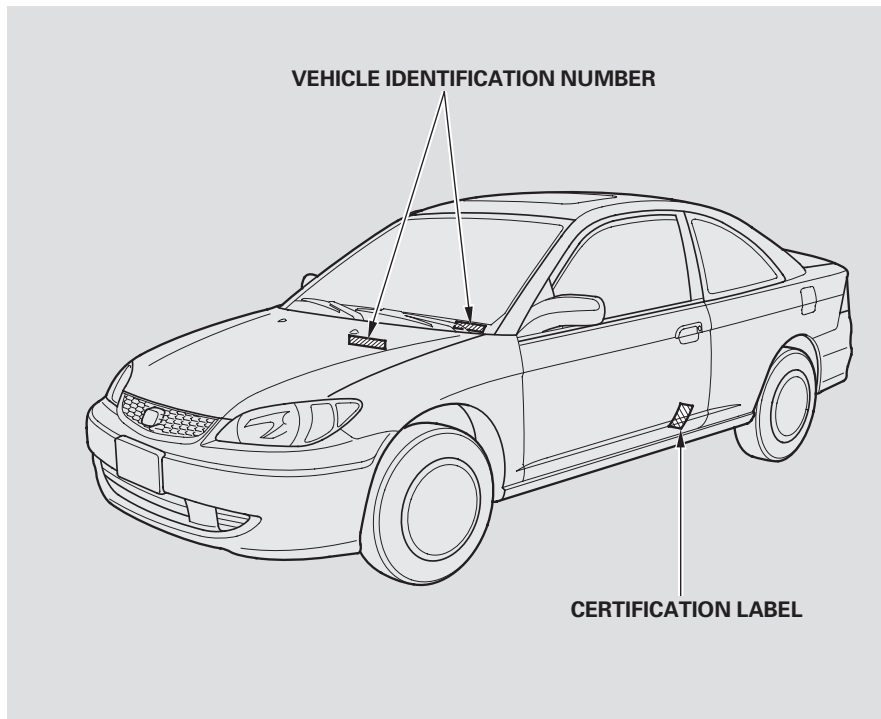

The Engine Number is stamped into the engine block.

The Transmission Number is on a label on top of the transmission.

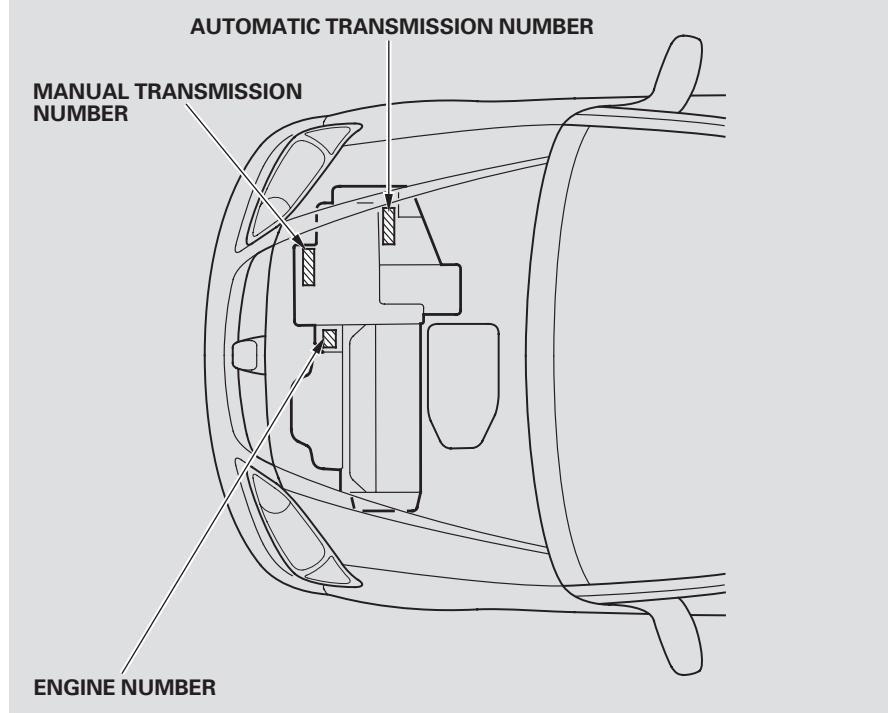

# Specifications

## Dimensions

Length	174.7 in (4,438 mm)	
Width	66.7 in (1,695 mm)	
Height	55.1 in (1,399 mm)	
Wheelbase	103.1 in (2,620 mm)	
Track	Front	57.9 in (1,470 mm)
	Rear	57.9 in (1,470 mm)

## Weights

Gross vehicle weight rating	See the certification label attached to the driver's doorjamb.
-----------------------------	--

## Engine

Type	Water cooled 4-stroke SOHC*1, SOHC VTEC*2 4-cylinder gasoline engine
Bore x Stroke	2.95 x 3.72 in (75.0 x 94.4 mm)
Displacement	102 cu-in (1,668 cm <sup>3</sup> )
Compression ratio	9.5*1
	9.9*2
Spark plugs	NGK: PZFR6F-11 DENSO: PKJ20CR-M11
Spark plug Gap	0.04 in (1.1 mm) <sup>+0</sup> <sub>+0.1mm</sub>

\*1 : U.S.: DX, LX  
Canada: DX, LX

\*2 : U.S.: HX, EX  
Canada: Si

## Capacities

Fuel tank		Approx. 13.2 US gal (50 ℓ)
Engine coolant	Change*3	
	Manual	1.03 US gal (3.9 ℓ)
	Automatic	1.00 US gal (3.8 ℓ)
	CVT	1.00 US gal (3.8 ℓ)
	Total	
	Manual	1.32 US gal (5.0 ℓ)
	Automatic	1.29 US gal (4.9 ℓ)
	CVT	1.29 US gal (4.9 ℓ)
Engine oil	Change*4	
	Including filter	3.4 US qt (3.2 ℓ)*5
	Without filter	3.7 US qt (3.5 ℓ)*6
		3.2 US qt (3.0 ℓ)*5
		3.5 US qt (3.3 ℓ)*6
	Total	4.4 US qt (4.2 ℓ)
Manual transmission fluid	Change	1.6 US qt (1.5 ℓ)
	Total	1.7 US qt (1.6 ℓ)
Automatic transmission fluid	Change	2.9 US qt (2.7 ℓ)
	Total	3.4 US qt (3.2 ℓ)*7
		6.3 US qt (6.0 ℓ)
		6.0 US qt (5.7 ℓ)*7
Windshield washer reservoir	U.S. Vehicles	2.6 US qt (2.5 ℓ)
	Canada Vehicles	4.8 US qt (4.5 ℓ)

\*3 : Including the coolant in the reserve tank and that remaining in the engine.

Reserve tank capacity: 0.108 US gal (0.41 ℓ)

\*4 : Excluding the oil remaining in the engine.

\*5 : U.S.: DX, LX Canada: DX, LX

\*6 : U.S.: HX, EX Canada: Si \*7 : HX

## Air Conditioning

Refrigerant type	HFC-134a (R-134a)
Charge quantity	17.6 – 19.4 oz (500 – 550 g)
Lubricant oil type	SP-10

## Lights

Headlights (HI)	12 V – 60 W (HB3)
Headlights (LO)	12 V – 51 W (HB4)
Front turn signal/Parking light	12 V – 24/2.2 CP
Rear turn signal lights	12 V – 21 W
Stop/Taillights	12 V – 21/5 W
Back-up lights	12 V – 18 W
High-mount stop light	12 V – 21 W
License plate lights	12 V – 3 CP
Ceiling light	12 V – 10 W
Front ceiling light* <sup>1</sup>	12 V – 5 W
Spotlights	12 V – 5 W * <sup>1</sup> 12 V – 8 W * <sup>2</sup>
Trunk light	12 V – 5 W

\* 1 : U.S.: EX  
Canada : Si

\* 2 : LX

## Battery

Capacity	12 V – 36 AH/5 HR
	12 V – 38 AH/5 HR

## Fuses

Interior	See page 202 or the fuse label attached to the inside of the fuse box door under the steering column.
Under-hood	See page 201 or the fuse box cover.

## Alignment

Toe-in	Front	0.00 in (0.0 mm)
	Rear	– 0.08 in (– 2.0 mm)
Camber	Front	0°
	Rear	– 45'
Caster	Front	2°14'

## Tires

Size	Front/Rear	P185/70R14 87S * <sup>3</sup> P185/65R15 86H * <sup>4</sup> P195/60R15 87H * <sup>5</sup>
	Spare	T115/70D14 88M * <sup>6</sup> T125/70D15 95M * <sup>7</sup>
Pressure	Front/Rear	30 psi (210 kPa , 2.1 kgf/cm <sup>2</sup> )
	Spare	60 psi (420 kPa , 4.2 kgf/cm <sup>2</sup> )

\* 3 : U.S.: DX, HX Canada: DX

\* 4 : Canada: LX

\* 5 : U.S.: LX, EX Canada: Si

\* 6 : U.S.: DX, HX and LX  
Canada : DX, LX and Si

\* 7 : U.S.: LX with ABS, EX  
Canada: LX with ABS, Si with ABS

# DOT Tire Quality Grading (U.S. Vehicles)

---

The tires on your vehicle meet all U.S. Federal Safety Requirements. All tires are also graded for treadwear, traction, and temperature performance according to Department of Transportation (DOT) standards. The following explains these gradings.

## **Uniform Tire Quality Grading**

Quality grades can be found where applicable on the tire sidewall between the tread shoulder and the maximum section width. For example:

**Treadwear 200**  
**Traction AA**  
**Temperature A**

All passenger vehicle tires must conform to Federal Safety Requirements in addition to these grades.

## **Treadwear**

The treadwear grade is a comparative rating based on the wear rate of the tire when tested under controlled conditions on a specified government test course. For example, a tire graded 150 would wear one and one-half (1 1/2) times as well on the government course as a tire graded 100. The relative performance of tires depends upon the actual conditions of their use, however, and may depart significantly from the norm due to variations in driving habits, service practices and differences in road characteristics and climate.

## **Traction – AA, A, B, C**

The traction grades, from highest to lowest, are AA, A, B, and C. Those grades represent the tire's ability to stop on wet pavement as measured under controlled conditions on specified government test surfaces of asphalt and concrete. A tire marked C may have poor traction performance.

**Warning:** The traction grade assigned to this tire is based on straight-ahead braking traction tests, and does not include acceleration, cornering, hydroplaning, or peak traction characteristics.

## Temperature – A, B, C

The temperature grades are A (the highest), B, and C, representing the tire's resistance to the generation of heat and its ability to dissipate heat when tested under controlled conditions on a specified indoor laboratory test wheel. Sustained high temperature can cause the material of the tire to degenerate and reduce tire life, and excessive temperature can lead to sudden tire failure. The grade C corresponds to a level of performance, which all passenger vehicle tires must meet under the Federal Motor Vehicle Safety Standard No. 109. Grades B and A represent higher levels of performance on the laboratory test wheel than the minimum required by law.

**Warning:** The temperature grade for this tire is established for a tire that is properly inflated and not over-loaded. Excessive speed, underinfla-

tion, or excessive loading, either separately or in combination, can cause heat buildup and possible tire failure.

## Tire Labeling

The tires that came on your vehicle have a number of markings. Those you should be aware of are described below.

### *Tire Size*

Whenever tires are replaced, they should be replaced with tires of the same size. Following is an example of tire size with an explanation of what each component means.

P225/55R16 94V

- P – Vehicle type (P indicates passenger vehicle).
- 225 – Tire width in millimeters.
- 55 – Aspect ratio (the tire's section height as a percentage of its width).

- R – Tire construction code (R indicates radial).
- 16 – Rim diameter in inches.
- 94 – Load index (a numerical code associated with the maximum load the tire can carry).
- V – Speed symbol (an alphabetical code indicating the maximum speed rating).

### *Tire Identification Number*

Tire Identification Number (TIN) is a group of numbers and letters that look like the following example TIN.

DOT B97R FW6X 2202

- DOT – This indicates that the tire meets all requirements of the U.S. Department of Transportation.
- B97R – Manufacturer's identification mark.
- FW6X – Tire type code.
- 2202 – Date of manufacture.

The burning of gasoline in your vehicle's engine produces several by-products. Some of these are carbon monoxide (CO), oxides of nitrogen (NOx) and hydrocarbons (HC). Gasoline evaporating from the tank also produces hydrocarbons. Controlling the production of NOx, CO, and HC is important to the environment. Under certain conditions of sunlight and climate, NOx and HC react to form photochemical "smog." Carbon monoxide does not contribute to smog creation, but it is a poisonous gas.

## **The Clean Air Act**

The United States Clean Air Act\* sets standards for automobile emissions. It also requires that automobile manufacturers explain to owners how their emissions controls work and what to do to maintain them. This section summarizes how the emissions controls work. Scheduled maintenance is on page [143](#).

\* In Canada, Honda vehicles comply with the Canadian emission requirements, as specified in an agreement with Environment Canada, at the time they are manufactured.

## **Crankcase Emissions Control System**

Your vehicle has a Positive Crankcase Ventilation System. This keeps gasses that build up in the engine's crankcase from going into the atmosphere. The Positive Crank-

case Ventilation valve routes them from the crankcase back to the intake manifold. They are then drawn into the engine and burned.

## **Evaporative Emissions Control System**

As gasoline evaporates in the fuel tank, an evaporative emissions control canister filled with charcoal adsorbs the vapor. It is stored in this canister while the engine is off. After the engine is started and warmed up, the vapor is drawn into the engine and burned during driving.

## **Onboard Refueling Vapor Recovery**

The Onboard Refueling Vapor Recovery (ORVR) system captures the fuel vapors during refueling. The vapors are adsorbed in a canister filled with activated carbon. While driving, the fuel vapors are drawn into the engine and burned off.

## **Exhaust Emissions Controls**

The exhaust emissions controls include four systems: PGM-FI, Ignition Timing Control, Exhaust Gas Recirculation and Three Way Catalytic Converter. These four systems work together to control the engine's combustion and minimize the amount of HC, CO, and NOx that comes out the tailpipe. The exhaust emissions control systems are separate from the crankcase and evaporative emissions control systems.

### ***PGM-FI System***

The PGM-FI System uses sequential multiport fuel injection. It has three subsystems: Air Intake, Engine Control, and Fuel Control. The Engine Control Module (ECM) or the Powertrain Control Module (PCM) uses various sensors to determine how much air is going into the engine. It then controls how much fuel to inject under all operat-

ing conditions.

### ***Ignition Timing Control System***

This system constantly adjusts the ignition timing, reducing the amount of HC, CO, and NOx produced.

### ***Exhaust Gas Recirculation (EGR) System***

The Exhaust Gas Recirculation (EGR) system takes some of the exhaust gas and routes it back into the intake manifold. Adding exhaust gas to the air/fuel mixture reduces the amount of NOx produced when the fuel is burned.

### ***Three Way Catalytic Converter***

The three way catalytic converter is in the exhaust system. Through chemical reactions, it converts HC, CO, and NOx in the engine's exhaust to carbon dioxide (CO<sub>2</sub>), nitrogen (N<sub>2</sub>), and water vapor.

## **Replacement Parts**

The emissions control systems are designed and certified to work together in reducing emissions to levels that comply with the Clean Air Act. To make sure the emissions remain low, you should use only new Honda replacement parts or their equivalent for repairs. Using lower quality parts may increase the emissions from your vehicle.

The emissions control systems are covered by warranties separate from the rest of your vehicle. Read your warranty manual for more information.



# Three Way Catalytic Converter

The three way catalytic converter contains precious metals that serve as catalysts, promoting chemical reactions to convert the exhaust gasses without affecting the metals. The catalytic converter is referred to as a three-way catalyst, since it acts on HC, CO, and NOx. A replacement unit must be an original Honda part or its equivalent.

The three way catalytic converter must operate at a high temperature for the chemical reactions to take place. It can set on fire any combustible materials that come near it. Park your vehicle away from high grass, dry leaves, or other flammables.

(U.S. EX and Canadian Si models)

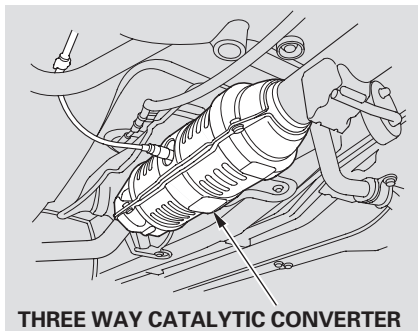

A defective three way catalytic converter contributes to air pollution, and can impair your engine's performance. Follow these guidelines to protect your vehicle's three way catalytic converter.

- Always use unleaded gasoline. Even a small amount of leaded gasoline can contaminate the catalyst metals, making the three way catalytic converter ineffective.

(U.S. DX, HX, LX and Canada DX, LX models)

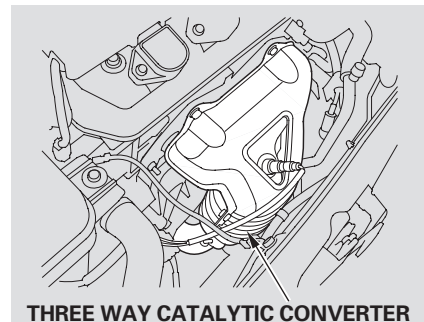

- Keep the engine tuned-up.
- Have your vehicle diagnosed and repaired if it is misfiring, back-firing, stalling, or otherwise not running properly.

## Testing of Readiness Codes

If you take your vehicle for a state emissions test shortly after the battery has been disconnected or gone dead, it may not pass the test. This is because of certain “readiness codes” that must be set in the on-board diagnostics for the emissions systems. These codes are erased when the battery is disconnected, and set again only after several days of driving under a variety of conditions.

If the testing facility determines that the readiness codes are not set, you will be requested to return at a later date to complete the test. If you must get the vehicle re-tested within the next two or three days, you can condition the vehicle for re-testing by doing the following.

- Make sure the gas tank is nearly, but not completely, full (around 3/4).
- Make sure the vehicle has been parked with the engine off for 8 hours or more.
- Make sure the ambient temperature is between 20° and 95° F.

- Without touching the accelerator pedal, start the engine, and let it idle for 20 seconds.
- Keep the vehicle in Park (automatic transmission) or Neutral (manual transmission). Increase the engine speed to 2,000 rpm and hold it there until the temperature gauge rises to at least 1/4 of the scale (approximately 3 minutes).

*CONTINUED*

# State Emissions Testing

---

- Select a nearby lightly traveled major highway where you can maintain a speed of 50 to 60 mph (80 to 97 km/h) for at least 20 minutes. Drive on the highway in D (A/T) or 5th (M/T). Do not use the cruise control. When traffic allows, drive for 90 seconds without moving the accelerator pedal. (Vehicle speed may vary slightly; this is okay.) If you cannot do this for a continuous 90 seconds because of traffic conditions, drive for at least 30 seconds, then repeat it two more times (for a total of 90 seconds).

- Then drive in city/suburban traffic for at least 10 minutes. When traffic conditions allow, let the vehicle coast for several seconds without using the accelerator pedal or the brake pedal.

If the testing facility determines the readiness codes are still not set, see your Honda dealer.

Customer Service Information.....	218
Warranty Coverages .....	219
Reporting Safety Defects (U.S. Vehicles) .....	220
Authorized Manuals.....	221

# Customer Service Information

---

Honda dealership personnel are trained professionals. They should be able to answer all your questions. If you encounter a problem that your dealership does not solve to your satisfaction, please discuss it with the dealership's management. The Service Manager or General Manager can help. Almost all problems are solved in this way.

If you are dissatisfied with the decision made by the dealership's management, contact your Honda Customer Service Office.

## U.S. Owners:

American Honda Motor Co., Inc.  
Automobile Customer Service  
Mail Stop 500-2N-7A  
1919 Torrance Boulevard  
Torrance, California 90501-2746

Tel: (800) 999-1009

## Canadian Owners:

### **CUSTOMER RELATIONS RELATIONS AVEC LA CLIENTÉLE**

Honda Canada Inc.  
715 Milner Avenue  
Toronto, ON  
M1B 2K8

Tel: 1-888-9-HONDA-9

Fax: Toll-free 1-877-939-0909  
Toronto (416) 287-4776

## In Puerto Rico and the U.S. Virgin Islands:

Bella International  
P.O. Box 190816  
San Juan, Puerto Rico 00919-0816

Tel: (787) 250-4318

When you call or write, please give us this information:

- Vehicle Identification Number (see page 206 )
- Name and address of the dealer who services your vehicle
- Date of purchase
- Mileage on your vehicle
- Your name, address, and telephone number
- A detailed description of the problem
- Name of the dealer who sold the vehicle to you

### U.S. Owners

Your new Honda is covered by these warranties:

***New Vehicle Limited Warranty*** — covers your new vehicle, except for the battery, emissions control systems and accessories, against defects in materials and workmanship.

***Emissions Control Systems Defects Warranty and Emissions***

***Performance Warranty*** — these two warranties cover your vehicle's emissions control systems. Time, mileage, and coverage are conditional. Please read the warranty manual for exact information.

***Original Equipment Battery Limited Warranty*** — this warranty gives up to 100 percent credit toward a replacement battery.

***Seat Belt Limited Warranty*** — a seat belt that fails to function properly is covered for the useful life of the vehicle.

***Rust Perforation Limited Warranty*** — all exterior body panels are covered for rust-through from the inside for the specified time period with no mileage limit.

***Accessory Limited Warranty*** — Honda Accessories are covered under this warranty. Time and mileage limits depend on the type of accessory and other factors. Please read your warranty manual for details.

***Replacement Parts Limited Warranty*** — covers all Honda replacement parts against defects in materials and workmanship.

***Replacement Battery Limited Warranty*** — provides prorated coverage for a replacement battery purchased from a Honda dealer.

***Replacement Muffler Lifetime Limited Warranty*** — provides coverage for as long as the purchaser of the muffler owns the vehicle.

Restrictions and exclusions apply to all these warranties. Please read the 2004 Honda Warranty Information booklet that came with your vehicle for precise information on warranty coverages. Your Honda's original tires are covered by their manufacturer. Tire warranty information is in a separate booklet.

### Canadian Owners

Please refer to the 2004 Warranty Manual that came with your vehicle.

## Reporting Safety Defects (U.S. Vehicles)

---

If you believe that your vehicle has a defect which could cause a crash or could cause injury or death, you should immediately inform the National Highway Traffic Safety Administration (NHTSA) in addition to notifying American Honda Motor Co., Inc.

If NHTSA receives similar complaints, it may open an investigation, and if it finds that a safety defect exists in a group of vehicles, it may order a recall and remedy campaign. However, NHTSA cannot become involved in individual problems between you, your dealer, or American Honda Motor Co., Inc.

To contact NHTSA, you may either call the Auto Safety Hotline toll-free at 1-800-424-9393 (or 366-0123 in Washington D.C. area) or write to: NHTSA, U.S. Department of Transportation, Washington, D.C. 20590. You can also obtain other information about motor vehicle safety from the Hotline.

## A

Accessories.....	120
ACCESSORY (Ignition Key Position) .....	71
Accessory Power Socket .....	88
Additives, Engine Oil.....	152
Airbag (SRS) .....	10, 22
Air Conditioning System.....	91
Air Outlets (Vents).....	90
Air Pressure, Tires .....	172
High Speed Driving.....	173
Normal Driving.....	172
Alcohol in Gasoline.....	212
Antifreeze .....	157
Anti-lock Brakes (ABS) Indicator Light .....	57, 139
Operation.....	139
Anti-theft Steering Column Lock.....	71
Audio System .....	94
Automatic Speed Control.....	110
Automatic Transmission.....	130
Capacity, Fluid .....	208
Checking Fluid Level.....	160
Shifting.....	130

Shift Lever Position Indicator ..	130
Shift Lever Positions .....	130
Shift Lock Release.....	133

## B

Battery Charging System Indicator.....	56, 195
Jump Starting .....	191
Maintenance.....	178
Specifications .....	209
Before Driving .....	113
Belts, Seat .....	8, 19
Beverage Holders.....	87
Booster Seats .....	45
Brakes Anti-lock System (ABS) .....	139
Break-in, New Linings .....	114
Bulb Replacement .....	164
Fluid .....	163
Parking.....	131
System Indicator.....	57, 197
Wear Indicators .....	138
Braking System.....	138
Break-in, New Car .....	114

Brightness Control, Instruments...	66
Brights, Headlights .....	65
Bulb Replacement Back-up Lights .....	167
Brake Lights.....	167
Front Parking Lights.....	166
Front Side Marker Lights.....	166
Headlights .....	164
High-mount Brake Light .....	168
Rear Side Marker Lights.....	167
Specifications .....	209
Turn Signal Lights.....	166
Bulbs, Halogen.....	164

## C

Capacities Chart.....	208
Carbon Monoxide Hazard .....	47
Carrying Cargo .....	122
Cassette Player Care .....	106
Operation.....	104
CAUTION, Explanation of .....	ii
CD Care .....	101

CONTINUED





<b>E</b>			
Economy, Fuel .....	119	Malfunction Indicator	
Emergencies		Lamp .....	58, 196
Jump Starting .....	119	Oil Pressure Indicator .....	56, 195
Towing .....	203	Oil, What Kind to Use .....	152
Hazard Warning Flashes .....	67	Overheating .....	192
Emergencies on the Road .....	182	Specifications .....	208
Battery, Jump Starting .....	191	Starting .....	127
Brake System Indicator .....	197	Ethanol in Gasoline .....	212
Changing a Flat Tire .....	183	Evaporative Emissions Controls ..	212
Charging System Indicator .....	195	Exhaust Fumes .....	47
Checking the Fuses .....	199	Expectant Mothers, Use of Seat	
Low Oil Pressure Indicator .....	195	Belts by .....	17
Malfunction Indicator Lamp .....	196		
Manually Closing Moonroof .....	198	<b>F</b>	
Overheated Engine .....	192	Fan, Interior .....	91
Emergency Brake .....	84	Features, Comfort and	
Emergency Flashers .....	67	Convenience .....	89
Emergency Towing .....	203	Filling the Fuel Tank .....	115
Emergency Trunk Opener .....	73	Filters	
Emissions Controls .....	212	Dust and Pollen .....	169
Engine		Oil .....	154
Coolant Temperature Gauge .....	61	5-speed Manual Transmission	
If it won't start .....	189	Checking Fluid Level .....	162
		Shifting the .....	128
		Flashers, Hazard Warning .....	67
		Flat Tire, Changing a .....	183
		Fluids	
		Automatic Transmission .....	160
		Brake .....	163
		Clutch .....	163
		Manual Transmission .....	162
		Power Steering .....	159
		Windshield Washer .....	156
		FM Stereo Radio	
		Reception .....	97
		Four-way Flashers .....	67
		Front Seat	
		Adjusting .....	11
		Airbags .....	22
		Fuel .....	114
		Economy .....	119
		Fill Door and Cap .....	115
		Gauge .....	60
		Octane Requirement .....	114
		Oxygenated .....	114
		Reserve Indicator .....	58
		Tank, Filling the .....	115
		Fuses, Checking the .....	199

CONTINUED

# Index

## G

Gas Mileage, Improving.....	119
Gasohol .....	114
Gasoline .....	114
Fuel Reserve Indicator.....	58
Gauge .....	60
Octane Requirement .....	114
Tank, Filling the.....	115
Gas Station Procedures.....	115
Gauges	
Engine Coolant Temperature ....	61
Fuel.....	60
Gearshift Lever Positions	
Automatic Transmission.....	130
5-speed Manual	
Transmission.....	129
Glove Box .....	87

## H

Halogen Headlight Bulbs.....	164
Hazard Warning Flashers.....	67
Headlights	
Daytime Running Lights.....	65
High Beam Indicator .....	58

Reminder Beeper.....	65
Replacing Halogen Bulbs .....	164
Turning on.....	65
Head Restraints .....	78
Heating and Cooling.....	90
High Altitude, Starting at.....	127
High-Low Beam Switch .....	65
High-mount Brake Light.....	168
Hood, Opening the .....	116
Horn.....	63
Hydraulic Clutch.....	163

## I

Identification Number, Vehicle....	206
Ignition	
Keys.....	69
Switch.....	71
Timing Control System.....	213
Important Safety Precautions .....	6
Indicators	
ABS (Anti-Lock Brake).....	57
Brake (Parking and Brake	
System) .....	57
Charging System .....	56

Cruise Control.....	58
DRL (Daytime Running	
Lights).....	57
High Beam.....	58
Key (Immobilizer System) .....	70
Low Fuel.....	58
Low Oil Pressure .....	56
Side Airbag Off .....	56
SRS .....	56
Turn Signal and Hazard	
Warning .....	58
Washer Level .....	58
Indicators, Instrument	
Panel.....	53
Infant Restraint .....	34
Infant Seats	
Lower Anchors .....	37
Tether Anchorage Points .....	42
Inflation, Proper Tire .....	172
High Speed Driving.....	173
Normal Driving.....	172
Inside Mirror .....	83
Inspection, Tire .....	174
Instrument Panel .....	2, 53
Instrument Panel Brightness .....	66
Interior Lights .....	85

Introduction..... **i**

**J**

Jacking up the Vehicle ..... **184**

Jack, Tire ..... **183**

Jump Starting ..... **191**

**K**

Keys..... **69**

**L**

Label, Certification..... **206**

Lane Change, Signaling ..... **65**

Lap/Shoulder Belts ..... **14, 19**

Lights

    Bulb Replacement ..... **164**

    Indicator..... **56**

    Parking..... **57**

    Turn Signal..... **58**

Load Limit ..... **123**

LOCK (Ignition Key Position) ..... **71**

Locks

    Anti-theft Steering Column ..... **71**

Fuel Fill Door ..... **115**

Power Door ..... **72**

Trunk ..... **72**

Low Coolant Level..... **118**

Low Fuel Indicator ..... **58**

Lower Anchors..... **38**

Lower Gear, Downshifting to a... **128**

Low Oil Pressure Indicator ... **56, 195**

Lubricant Specifications Chart ... **208**

Luggage ..... **122**

**M**

Maintenance..... **141**

    Owner Maintenance Checks... **144**

    Record..... **149-150**

    Required Indicator..... **62**

    Safety..... **142**

    Schedule ..... **145-148**

Malfunction Indicator Lamp .. **58, 196**

Manual Transmission..... **128**

Manual Transmission Fluid ..... **162**

Meters, Gauges..... **60**

Methanol in Gasoline ..... **114**

Mirrors, Adjusting..... **83**

Modifying Your Vehicle..... **121**

Moonroof ..... **82**

    Closing Manually ..... **198**

    Operation..... **82**

**N**

Neutral Gear Position..... **131**

New Vehicle Break-in ..... **114**

Normal Shift Speeds..... **129**

NOTICE, Explanation of..... **i**

Numbers, Identification..... **206**

**O**

Octane Requirement, Gasoline ... **114**

Odometer..... **60**

Odometer, Trip ..... **60**

Oil

    Change, How to ..... **154**

    Change, When to ..... **145**

    Checking Engine ..... **117**

    Pressure Indicator ..... **56, 195**

    Selecting Proper Viscosity

        Chart ..... **153**

*CONTINUED*

# Index

ON (Ignition Key Position) .....	71
Onboard Refueling Vapor Recovery .....	212
Outside Mirrors .....	83
Overheating, Engine .....	192
Owner Maintenance Checks.....	144
Oxygenated Fuels.....	212

## P

Panel Brightness Control .....	66
Park Gear Position.....	131
Parking.....	137
Parking Brake .....	84
Parking Brake and Brake System Indicator.....	57
Parking Lights.....	166
Parking Over Things that Burn...	214
PGM-FI System.....	213
Power Door Locks.....	72
Power Socket Locations.....	88
Power Windows .....	81
Pregnancy, Using Seat Belts .....	17
Protecting Adults and Teens.....	11
Additional Safety Precautions....	18
Advice for Pregnant Women.....	17

Protecting Children.....	29
General Guideline.....	29
Installing a Child Seat .....	37
Protecting Infants.....	34
Protecting Larger Children.....	43
Protecting Small Children .....	35
Selecting Child Seats.....	36
Using Child Seats with Tethers.....	42
Using Lower Anchors .....	38

## R

Radiator Overheating.....	192
Radio/CD/Cassette Sound System.....	94
Readiness Codes.....	196, 215
Rear Lights, Bulb Replacement.....	167
Rear Seat, Folding .....	79
Rear View Mirror.....	83
Rear Window Defogger .....	67
Reclining the Seat Backs .....	76
Recommended Shift Speeds .....	129
Reminder Lights .....	56
Remote Transmitter.....	74

## Replacement Information

Dust and Pollen Filter .....	169
Engine Oil and Filter .....	154
Fuses .....	199
Light Bulbs .....	164
Schedule .....	143
Spark Plugs.....	208
Timing Belt.....	162
Tires .....	172
Wiper Blades.....	170

## Replacing Seat Belts After a

Crash.....	21
Reserve Tank, Engine Coolant.....	118, 157
Restraint, Child .....	29
Reverse Gear Position.....	131
Roof Rack .....	124
Rotation, Tire .....	175

## S

Safety Belts.....	8, 19
Safety Defects, Reporting* .....	220
Safety Features .....	7
Airbags.....	10
Seat Belts.....	8

- Safety Labels, Location of ..... 48  
 Safety Messages ..... ii  
 Seat Belts ..... 8, 19  
   Additional Information..... 19  
   Automatic Seat Belt  
     Tensioners..... 20  
   Cleaning..... 169  
   Lap/Shoulder Belt..... 14, 19  
   Maintenance..... 21  
   Reminder Light and Beeper..... 56  
   System Components..... 19  
   Use During Pregnancy..... 18  
   Wearing a Lap/Shoulder Belt.... 19  
 Seats, Adjusting the..... 76  
 Serial Number ..... 206  
 Service Intervals ..... 145  
 Service Manual\* ..... 221  
 Service Station Procedures ..... 115  
 Setting the Clock ..... 108  
 Shift Lever Position Indicator ..... 130  
 Shift Lock Release..... 133  
 Side Airbags ..... 10, 25  
   Cutoff Indicator ..... 56  
 Side Marker Lights, Bulb  
   Replacement in ..... 166, 168  
 Signaling Turns..... 65  
 Snow Tires..... 177  
 Sound System..... 94  
 Spare Tire  
   Inflating..... 172  
   Specifications ..... 209  
 Specifications Charts..... 208  
 Speed Control..... 110  
 SRS, Additional Information..... 22  
   Additional Safety Precautions.... 28  
   Airbag Service..... 28  
   How the Passenger Airbag  
     Cutoff Indicator Light  
       Works..... 27  
   How the SRS Indicator  
     Works..... 26  
   How Your Front Airbags  
     Work..... 22  
   How Your Side Airbags Work.... 25  
   SRS Components ..... 22  
 SRS Indicator..... 26, 56  
 START (Ignition Key Position) .... 71  
   Testing of Readiness Codes.... 215  
 Starting the Engine..... 127  
   In Cold Weather at High  
     Altitude ..... 127  
   With a Dead Battery ..... 191  
 State Emissions Testing ..... 215  
 Steam Coming from Engine..... 192  
 Steering Wheel  
   Adjustment ..... 68  
   Anti-theft Column Lock ..... 71  
   Steering Wheel Buttons..... 63  
 Stereo Sound System ..... 94  
 Storing Your Vehicle ..... 179  
 Supplemental Restraint  
   System..... 10, 22  
   Servicing ..... 28  
   SRS Indicator..... 26, 56  
   System Components..... 22  
 Synthetic Oil..... 153
- T**
- Taillights, Changing  
   Bulbs in ..... 167  
 Taking Care of the Unexpected .. 181  
 Tape Player..... 104

CONTINUED



---

Compact Spare .....	182
Wrench .....	184
Windows	
Operating the Power .....	81
Rear, Defogger .....	67
Windshield	
Cleaning .....	64
Defroster .....	93
Washers .....	64
Wipers, Windshield	
Changing Blades.....	170
Operation .....	64
Worn Tires .....	175
Wrecker, Emergency Towing.....	203

\* : U.S. and Canada only



# Service Information Summary

---

**Gasoline:**

Unleaded gasoline, pump octane number of 86 or higher.

**Fuel Tank Capacity:**

13.2 US gal (50 ℓ)

**Recommended Engine Oil:**

API Premium grade 5W-20 detergent oil (see page [152](#)).

Oil change capacity (including filter):

U.S.: DX, LX

Canada: DX, LX

3.4 US qt (3.2 ℓ)

U.S.: HX, EX

Canada: Si

3.7 US qt (3.5 ℓ)

**Automatic Transmission Fluid:**

Honda ATF-Z1 (Automatic Transmission Fluid) preferred, or a DEXRON® III ATF as a temporary replacement (see page [161](#)).

HX model (CVT) only:

Use Honda ATF-Z1 (Automatic Transmission Fluid) only

**5-speed Manual Transmission Fluid:**

Honda Manual Transmission Fluid preferred, or an SAE 10W-30 or 10W-40 motor oil as a temporary replacement (see page [162](#)).

Capacity (including differential):

1.6 US qt (1.5 ℓ)

**Power Steering Fluid:**

Honda Power Steering Fluid preferred, or another brand of power steering fluid as a temporary replacement. Do not use ATF (see page [159](#)).

**Brake Fluid:**

Honda Heavy Duty Brake Fluid DOT 3 preferred, or a DOT 3 or DOT 4 brake fluid as a temporary replacement (see page [163](#)).

**Tire Pressure (measured cold):**

Front/Rear:

30 psi (210 kPa , 2.1 kgf/cm<sup>2</sup>)

Spare Tire:

60 psi (420 kPa , 4.2 kgf/cm<sup>2</sup>)