

# 2006 Civic Coupe Online Reference Owner's Manual

Use these links (and links throughout this manual) to navigate through this reference.  
For a printed owner's manual, click on authorized manuals or go to [www.helminc.com](http://www.helminc.com).

## Contents

---

### Owner's Identification Form

<b>Introduction</b> .....	<b>i</b>
<b>A Few Words About Safety</b> .....	<b>ii</b>
<b>Your Vehicle at a Glance</b> .....	<b>3</b>
<b>Driver and Passenger Safety</b> .....	<b>5</b>
Proper use and care of your vehicle's seat belts, and Supplemental Restraint System.	
<b>Instruments and Controls</b> .....	<b>53</b>
Instrument panel indicator and gauge, and how to use dashboard and steering column controls.	
<b>Comfort and Convenience Features</b> .....	<b>109</b>
How to operate the climate control system, the audio system, and other convenience features.	
<b>Before Driving</b> .....	<b>179</b>
What gasoline to use, how to break-in your new vehicle, and how to load luggage and other cargo.	
<b>Driving</b> .....	<b>191</b>
The proper way to start the engine, shift the transmission, and park, plus towing a trailer.	
<b>Maintenance</b> .....	<b>207</b>
The Maintenance Schedule shows you when you need to take your vehicle to the dealer.	
<b>Taking Care of the Unexpected</b> .....	<b>251</b>
This section covers several problems motorists sometimes experience, and how to handle them.	
<b>Technical Information</b> .....	<b>275</b>
ID numbers, dimensions, capacities, and technical information.	
<b>Warranty and Customer Relations (U.S. and Canada)</b> .....	<b>287</b>
A summary of the warranties covering your new Honda, and how to contact us.	
<b>Authorized Manuals (U.S. only)</b> .....	<b>291</b>
How to order manuals and other technical literature.	
<b>Index</b> .....	<b>I</b>

### Service Information Summary

A summary of information you need when you pull up to the fuel pump.

### Navigation System

Congratulations! Your selection of a 2006 Honda Civic was a wise investment. It will give you years of driving pleasure.

One of the best ways to enhance the enjoyment of your new vehicle is to read this manual. In it, you will learn how to operate its driving controls and convenience items. Afterwards, keep this owner's manual in your vehicle so you can refer to it at any time.

Several warranties protect your new vehicle. Read the warranty booklet thoroughly so you understand the coverages and are aware of your rights and responsibilities.

Maintaining your vehicle according to the schedules given in this manual helps to keep your driving trouble-free while it preserves your investment. When your vehicle needs maintenance, keep in mind that your dealer's staff is specially trained in servicing the many systems unique to your vehicle. Your dealer is dedicated to your satisfaction and will be pleased to answer any questions and concerns.

As you read this manual, you will find information that is preceded by a **NOTICE** symbol. This information is intended to help you avoid damage to your vehicle, other property, or the environment.

### California Proposition 65 Warning

**WARNING:** This product contains or emits chemicals known to the state of California to cause cancer and birth defects or other reproductive harm.

### Event Data Recorders

This vehicle is equipped with one or more recording devices commonly referred to as event data recorders or sensing and diagnostic modules.

# A Few Words About Safety

---

Your safety, and the safety of others, is very important. And operating this vehicle safely is an important responsibility.

To help you make informed decisions about safety, we have provided operating procedures and other information on labels and in this manual. This information alerts you to potential hazards that could hurt you or others.

Of course, it is not practical or possible to warn you about all the hazards associated with operating or maintaining your vehicle. You must use your own good judgement.

You will find this important safety information in a variety of forms, including:

- **Safety Labels** – on the vehicle.
- **Safety Messages** – preceded by a safety alert symbol  and one of three signal words: **DANGER**, **WARNING**, or **CAUTION**. These signal words mean:

 **DANGER**

You **WILL** be **KILLED** or **SERIOUSLY HURT** if you don't follow instructions.

 **WARNING**

You **CAN** be **KILLED** or **SERIOUSLY HURT** if you don't follow instructions.

 **CAUTION**

You **CAN** be **HURT** if you don't follow instructions.

- **Safety Headings** – such as Important Safety Reminders or Important Safety Precautions.
- **Safety Section** – such as Driver and Passenger Safety.
- **Instructions** – how to use this vehicle correctly and safely.

This entire book is filled with important safety information – please read it carefully.

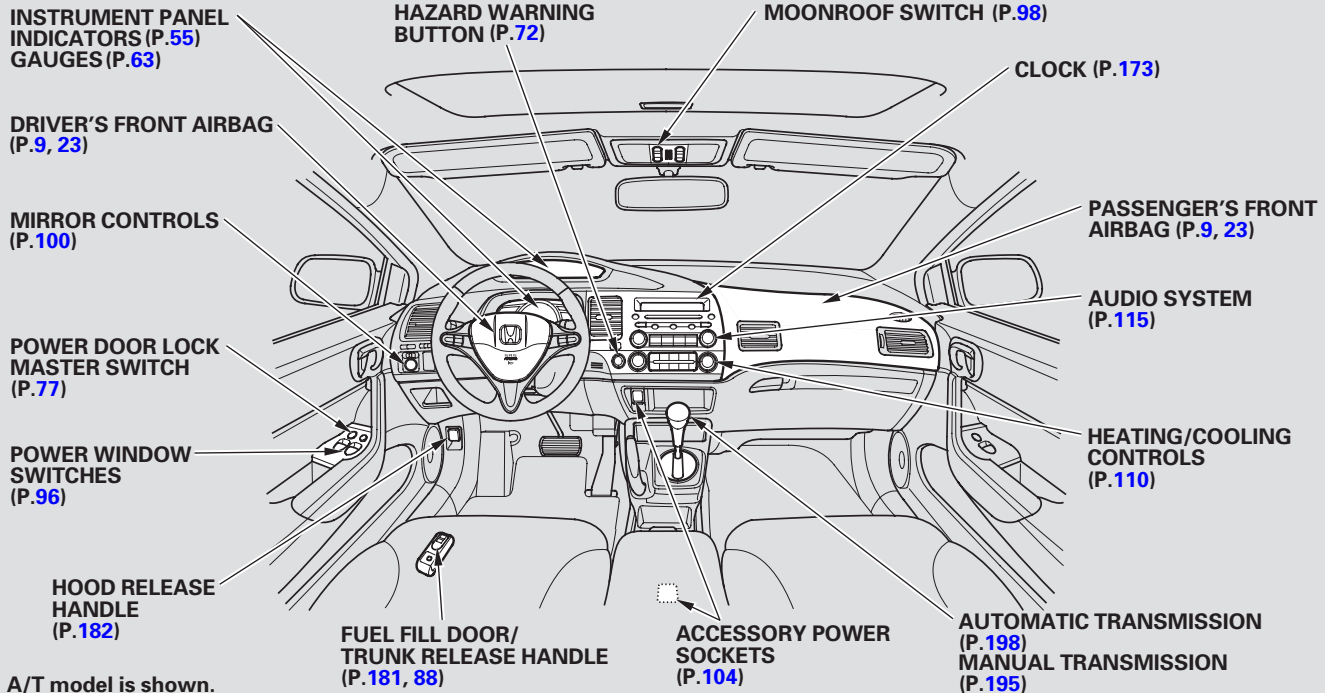

# Your Vehicle at a Glance

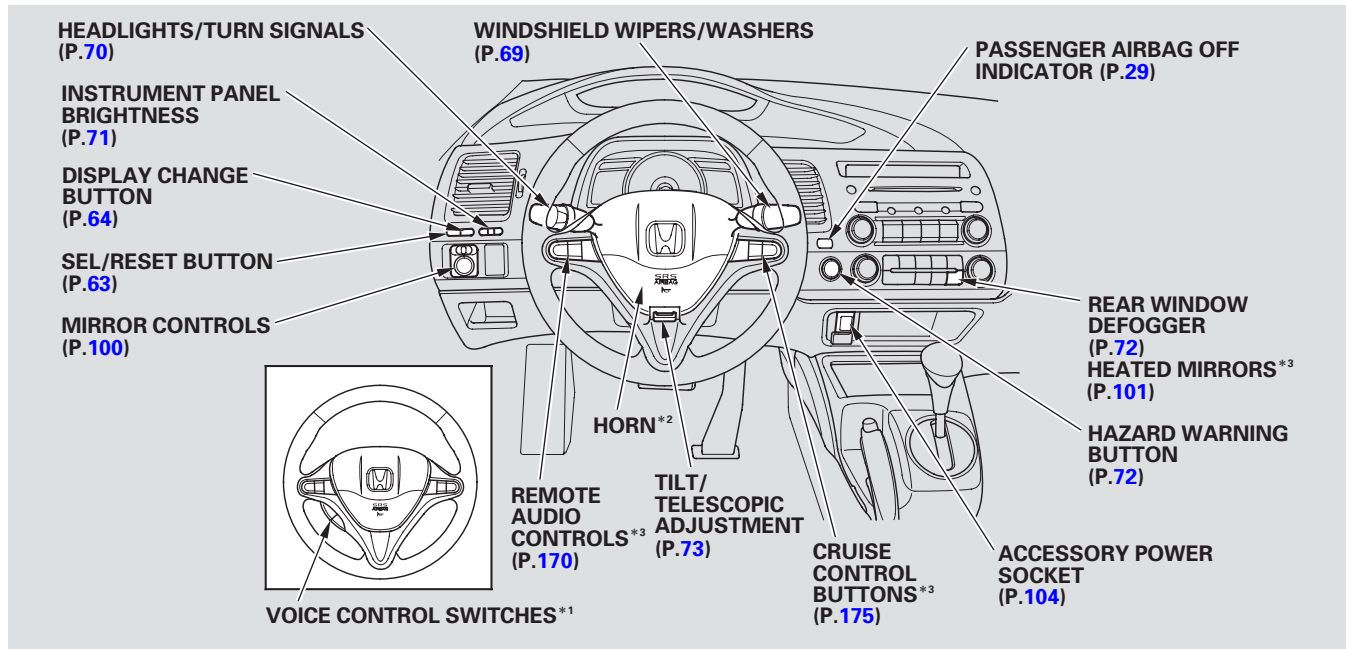

\* 1 : Only on vehicles equipped with navigation system. Refer to the navigation system manual.

\* 2 : To use the horn, press the center pad of the steering wheel.

\* 3 : If equipped.

This section gives you important information about how to protect yourself and your passengers. It shows you how to use seat belts. It explains how your airbags work. And it tells you how to properly restrain infants and children in your vehicle.

Important Safety Precautions .....	6
Your Vehicle's Safety Features.....	7
Protecting Adults and Teens.....	11
1. Close and Lock the Doors .....	11
2. Adjust the Front Seats .....	11
3. Adjust the Seat-Backs .....	12
4. Adjust the Head Restraints ....	13
5. Fasten and Position the Seat Belts .....	14
6. Maintain a Proper Sitting Position .....	15
Advice for Pregnant Women.....	16
Additional Safety Precautions....	16

Additional Information About Your Seat Belts .....	18
Seat Belt System Components...	18
Lap/Shoulder Belt.....	19
Automatic Seat Belt Tensioners.....	19
Seat Belt Maintenance .....	20
Additional Information About Your Airbags .....	21
Airbag System Components.....	21
How Your Front Airbags Work.....	23
How Your Side Airbags Work....	26
How the Side Curtain Airbags Work.....	28
How the SRS Indicator Works... ..	28
How the Side Airbag Off Indicator Works .....	29
How the Passenger Airbag Off Indicator Works.....	29
Airbag Service .....	30
Additional Safety Precautions....	31
Protecting Children – General Guidelines.....	32
All Children Must Be Restrained .....	32

All Children Should Sit in a Back Seat .....	33
The Passenger's Front Airbag Can Pose Serious Risks .....	33
If You Must Drive with Several Children .....	35
If a Child Requires Close Attention .....	35
Additional Safety Precautions....	35
Protecting Infants and Small Children .....	37
Protecting Infants.....	37
Protecting Small Children .....	38
Selecting a Child Seat.....	39
Installing a Child Seat .....	40
With LATCH.....	41
With a Lap/Shoulder Belt .....	43
With a Tether .....	45
Protecting Larger Children .....	46
Checking Seat Belt Fit .....	46
Using a Booster Seat.....	47
When Can a Larger Child Sit in Front.....	48
Additional Safety Precautions....	49
Carbon Monoxide Hazard .....	50
Safety Labels .....	51

# Important Safety Precautions

---

You'll find many safety recommendations throughout this section, and throughout this manual. The recommendations on this page are the ones we consider to be the most important.

## Always Wear Your Seat Belt

A seat belt is your best protection in all types of collisions. Airbags are designed to supplement seat belts, not replace them. So even though your vehicle is equipped with airbags, make sure you and your passengers always wear your seat belts, and wear them properly (see page 14).

## Restrain All Children

Children age 12 and under should ride properly restrained in a back seat, not the front seat. Infants and small children should be restrained in a child seat. Larger children should use a booster seat and a lap/shoulder belt until they can use the belt properly without a booster seat (see pages 32 – 49).

## Be Aware of Airbag Hazards

While airbags can save lives, they can cause serious or fatal injuries to occupants who sit too close to them, or are not properly restrained. Infants, young children, and short adults are at the greatest risk. Be sure to follow all instructions and warnings in this manual.

## Don't Drink and Drive

Alcohol and driving don't mix. Even one drink can reduce your ability to respond to changing conditions, and your reaction time gets worse with

every additional drink. So don't drink and drive, and don't let your friends drink and drive, either.

## Control Your Speed

Excessive speed is a major factor in crash injuries and deaths. Generally, the higher the speed, the greater the risk, but serious injuries can also occur at lower speeds. Never drive faster than is safe for current conditions, regardless of the maximum speed posted.

## Keep Your Vehicle in Safe Condition

Having a tire blowout or a mechanical failure can be extremely hazardous. To reduce the possibility of such problems, check your tire pressures and condition frequently, and perform all regularly scheduled maintenance (see page 209).

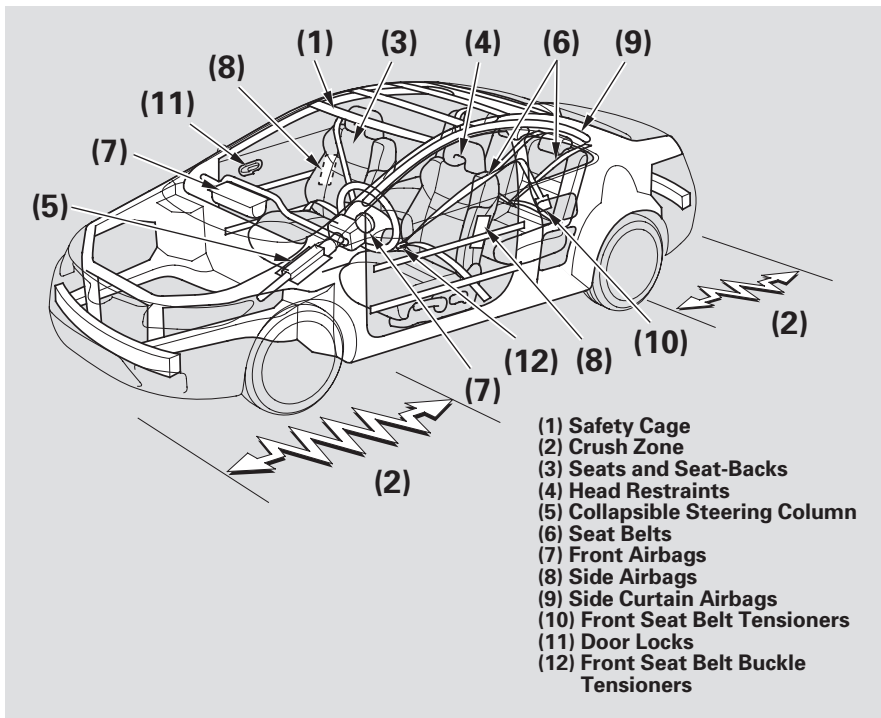

Your vehicle is equipped with many features that work together to protect you and your passengers during a crash.

Some features do not require any action on your part. These include a strong steel framework that forms a safety cage around the passenger compartment; front and rear crush zones; a collapsible steering column; and tensioners that tighten the front seat belts in a crash.

However, you and your passengers can't take full advantage of these features unless you remain sitting in a proper position and *always wear your seat belts*. In fact, some safety features can contribute to injuries if they are not used properly.

The following pages explain how you can take an active role in protecting yourself and your passengers.



# Your Vehicle's Safety Features

---

## Seat Belts

Your vehicle is equipped with seat belts in all seating positions.

Your seat belt system also includes an indicator on the instrument panel and a beeper to remind you and your passengers to fasten your seat belts.

### *Why Wear Seat Belts*

Seat belts are the single most effective safety device for adults and larger children. (Infants and smaller children must be properly restrained in child seats.)

Not wearing a seat belt properly increases the chance of serious injury or death in a crash, even though your vehicle has airbags.

In addition, most states and all Canadian provinces require you to wear seat belts.

## **⚠ WARNING**

Not wearing a seat belt properly increases the chance of serious injury or death in a crash, even though your vehicle has airbags.

Be sure you and your passengers always wear seat belts and wear them properly.

When properly worn, seat belts:

- Keep you connected to the vehicle so you can take advantage of the vehicle's built-in safety features.
- Help protect you in almost every type of crash, including frontal, side, and rear impacts and rollovers.

- Help keep you from being thrown against the inside of the vehicle and against other occupants.
- Keep you from being thrown out of the vehicle.
- Help keep you in a good position should the airbags ever deploy. A good position reduces the risk of injury from an inflating airbag and allows you to get the best advantage from the airbag.

Of course, seat belts cannot completely protect you in every crash. But in most cases, seat belts can reduce your risk of serious injury.

### *What You Should Do:*

Always wear your seat belt, and make sure you wear it properly.

## Airbags

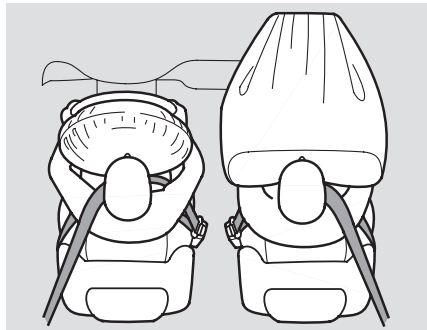

Your vehicle has a supplemental restraint system (SRS) with front airbags to help protect the heads and chests of the driver and a front seat passenger during a moderate to severe frontal collision (see page 23 for more information on how your front airbags work).

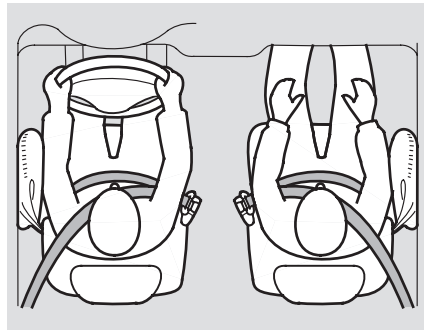

Your vehicle also has side airbags to help protect the upper torso of the driver or a front seat passenger during a moderate to severe side impact (see page 26 for more information on how your side airbags work).

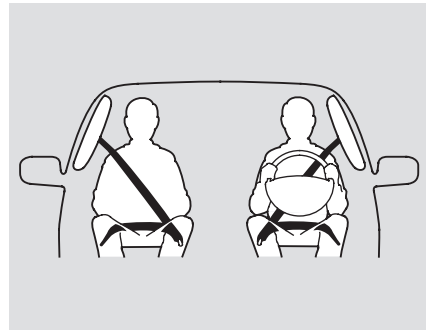

Your vehicle also has side curtain airbags to help protect the heads of the driver, front passenger, and passengers in the outer rear seating positions during a moderate to severe side impact (see page 28 for more information on how your side curtain airbags work).

CONTINUED

# Your Vehicle's Safety Features

---

The most important things you need to know about your airbags are:

- ***Airbags do not replace seat belts.*** They are designed to supplement the seat belts.
- ***Airbags offer no protection in rear impacts, or minor frontal or side collisions.***
- ***Airbags can pose hazards.*** To do their job, airbags must inflate with tremendous force. So while airbags help save lives, they can cause minor injuries or more serious or even fatal injuries if occupants are not properly restrained or sitting properly.

***What you should do:*** Always wear your seat belt properly, and sit upright and as far back from the steering wheel as possible while allowing full control of the vehicle. A front passenger should move their seat as far back from the dashboard as possible.

The rest of this section gives more detailed information about how you can maximize your safety.

Remember, however, that no safety system can prevent all injuries or deaths that can occur in a severe crash, even when seat belts are properly worn and the airbags deploy.

## Introduction

The following pages provide instructions on how to properly protect the driver, adult passengers, and teenage children who are large enough and mature enough to drive or ride in the front.

See pages [32](#) – [36](#) for important guidelines on how to properly protect infants, small children, and larger children who ride in your vehicle.

## 1. Close and Lock the Doors

After everyone has entered the vehicle, be sure the doors are closed and locked.



Your vehicle has a door-open indicator on the instrument panel to indicate when either door is not tightly closed.

Locking the doors reduces the chance of someone being thrown out of the vehicle during a crash, and it helps prevent passengers from accidentally opening a door and falling out.

Locking the doors also helps prevent an outsider from unexpectedly opening a door when you come to a stop.

See page [77](#) for how to lock the doors, and page [61](#) for how the door monitor indicator works.

Some models have auto door locking/unlocking features. For more information, see page [78](#).

## 2. Adjust the Front Seats

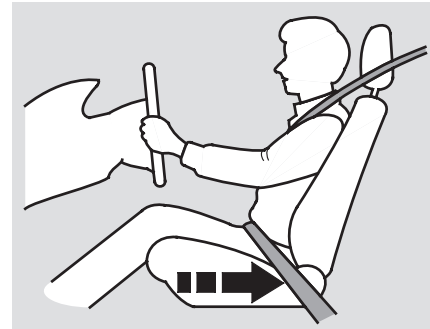

Adjust the driver's seat as far to the rear as possible while allowing you to maintain full control of the vehicle. Have a front passenger adjust their seat as far to the rear as possible.

*CONTINUED*

# Protecting Adults and Teens

If you sit too close to the steering wheel or dashboard, you can be seriously injured by an inflating front airbag, or by striking the steering wheel or dashboard.

The National Highway Traffic Safety Administration and Transport Canada recommend that drivers allow at least 10 inches (25 cm) between the center of the steering wheel and the chest. In addition to adjusting the seat, you can adjust the steering wheel up and down, and in and out (see page 73 ).

If you cannot get far enough away from the steering wheel and still reach the controls, we recommend that you investigate whether some type of adaptive equipment may help.

## ⚠ WARNING

Sitting too close to a front airbag can result in serious injury or death if the front airbags inflate.

Always sit as far back from the front airbags as possible.

Once your seat is adjusted correctly, rock it back and forth to make sure the seat is locked in position.

See page 90 for how to adjust the front seats.

## 3. Adjust the Seat-Backs

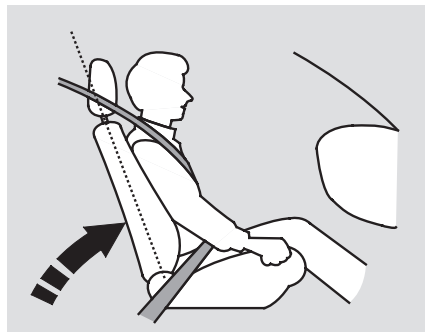

Adjust the driver's seat-back to a comfortable, upright position, leaving ample space between your chest and the airbag cover in the center of the steering wheel.

Passengers with adjustable seat-backs should also adjust their seat-back to a comfortable, upright position.

## **⚠ WARNING**

Reclining the seat-back too far can result in serious injury or death in a crash.

Adjust the seat-back to an upright position, and sit well back in the seat.

Reclining a seat-back so that the shoulder part of the belt no longer rests against the occupant's chest reduces the protective capability of the belt. It also increases the chance of sliding under the belt in a crash and being seriously injured. The farther a seat-back is reclined, the greater the risk of injury.

See page [90](#) for how to adjust the seat-backs.

## 4. Adjust the Head Restraints

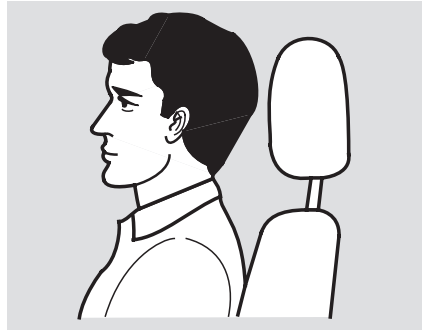

Adjust the driver's head restraint so the back of your head rests against the center of the restraint.

Have passengers adjust their head restraints properly as well. Taller persons should adjust their restraint as high as possible.

When a passenger is seated in the rear center seating position, make sure the head restraint is adjusted to its highest position.

## **⚠ WARNING**

Improperly positioning head restraints reduces their effectiveness and you can be seriously injured in a crash.

Make sure head restraints are in place and positioned properly before driving.

Properly adjusted head restraints will help protect occupants from whiplash and other crash injuries.

See page [93](#) for how to adjust the head restraints.

*CONTINUED*

# Protecting Adults and Teens

## 5. Fasten and Position the Seat Belts

Insert the latch plate into the buckle, then tug on the belt to make sure the belt is securely latched. Check that the belt is not twisted, because a twisted belt can cause serious injuries in a crash.



Position the lap part of the belt as low as possible across your hips, then pull up on the shoulder part of the belt so the lap part fits snugly. This lets your strong pelvic bones take the force of a crash and reduces the chance of internal injuries.

If necessary, pull up on the belt again to remove any slack, then check that the belt rests across the center of your chest and over your shoulder.

This spreads the forces of a crash over the strongest bones in your upper body.

### **⚠ WARNING**

Improperly positioning the seat belts can cause serious injury or death in a crash.

Make sure all seat belts are properly positioned before driving.

*Never place the shoulder portion of a lap/shoulder belt under your arm or behind your back.* This could cause very serious injuries in a crash.

If a seat belt does not seem to work properly, it may not protect the occupant in a crash.

*No one should sit in a seat with an inoperative seat belt.* Using a seat belt that is not working properly can result in serious injury or death. Have your dealer check the belt as soon as possible.

See page 18 for additional information about your seat belts and how to take care of them.

## 6. Maintain a Proper Sitting Position

After all occupants have adjusted their seats and put on seat belts, it is very important that they continue to sit upright, well back in their seats, with their feet on the floor, until the vehicle is parked and the engine is off.

Sitting improperly can increase the chance of injury during a crash. For example, if an occupant slouches, lies down, turns sideways, sits forward, leans forward or sideways, or puts one or both feet up, the chance of injury during a crash is greatly increased.

In addition, an occupant who is out of position in the front seat can be seriously or fatally injured in a crash by striking interior parts of the vehicle or being struck by an inflating front airbag.

### **WARNING**

Sitting improperly or out of position can result in serious injury or death in a crash.

Always sit upright, well back in the seat, with your feet on the floor.



## Advice for Pregnant Women



If you are pregnant, the best way to protect yourself and your unborn child when driving or riding in a vehicle is to always wear a seat belt, and keep the lap part of the belt as low as possible across the hips.

When driving, remember to sit upright and adjust the seat as far back as possible while allowing full control of the vehicle. When riding as a front passenger, adjust the seat as far back as possible.

This will reduce the risk of injuries to both you and your unborn child that can be caused by a crash or an inflating front airbag.

Each time you have a checkup, ask your doctor if it's okay for you to drive.

## Additional Safety Precautions

- *Two people should never use the same seat belt.* If they do, they could be very seriously injured in a crash.
- *Do not put any accessories on seat belts.* Devices intended to improve occupant comfort or reposition the shoulder part of a seat belt can reduce the protective capability of the belt and increase the chance of serious injury in a crash.
- *Do not place hard or sharp objects between yourself and a front airbag.* Carrying hard or sharp objects on your lap, or driving with a pipe or other sharp object in your mouth, can result in injuries if your front airbag inflates.

- ***Keep your hands and arms away from the airbag covers.*** If your hands or arms are close to an airbag cover, they could be injured if the airbag inflates.
  - ***Do not attach or place objects on the front airbag covers.*** Objects on the covers marked “SRS AIRBAG” could interfere with the proper operation of the airbags or be propelled inside the vehicle and hurt someone if the airbags inflate.
  - ***Do not attach hard objects on or near a door.*** If a side airbag or a side curtain airbag inflates, a cup holder or other hard object attached on or near the door could be propelled inside the vehicle and hurt someone.
- ***Never let passengers ride on top of a folded-down rear seat.*** If they do, they could be very seriously injured in a crash.

## Additional Information About Your Seat Belts

---

### Seat Belt System Components

Your seat belt system includes lap/shoulder belts in all five seating positions. The front seat belts are also equipped with automatic seat belt tensioners.



The seat belt system includes an indicator on the instrument panel and a beeper to remind you and your passengers to fasten your seat belts.

This system monitors the front seat belts.

If you turn the ignition switch to the ON (II) position before your seat belt is fastened, the beeper will sound and the indicator will flash. If your seat belt is not fastened before the beeper stops, the indicator will stop flashing but remain on.

If a front passenger does not fasten their seat belt, the indicator will come on about 6 seconds after the ignition switch is turned to the ON (II) position.

If either the driver or a front passenger does not fasten their seat belt while driving, the beeper will sound and the indicator will flash again at regular intervals.

When no one is sitting in the front passenger's seat, or a small child is riding there, the indicator will not come on and the beeper will not sound.

The seat belts use the same monitoring system as the front airbags. The system may not work properly under these conditions:

- Placing heavy items on the front passenger's seat.
- The front passenger is not sitting properly.
- The front passenger's seat-back is pressed forward by a folded-down rear seat.

Have your vehicle checked by a dealer if the indicator comes on or the beeper sounds when there is no front passenger or objects on the front seat.

## Lap/Shoulder Belt

The lap and shoulder belt goes over your shoulder, across your chest, and across your hips.

To fasten the belt, insert the latch plate into the buckle, then tug on the belt to make sure the buckle is latched (see page 14 for how to properly position the belt).

To unlock the belt, press the red PRESS button on the buckle. Guide the belt across your body so that it retracts completely. After exiting the vehicle, be sure the belt is out of the way and will not get closed in the door.

All seat belts have an emergency locking retractor. In normal driving, the retractor lets you move freely in your seat while it keeps some tension on the belt. During a collision or sudden stop, the retractor automatically locks the belt to help restrain your body.

The seat belts in all seating positions except the driver's have an additional locking mechanism that must be activated to secure a child seat (see page 43).

If the shoulder part of the belt is pulled all the way out, the locking mechanism will activate. The belt will retract, but it will not allow the passenger to move freely.

To deactivate the locking mechanism, unlatch the buckle and let the seat belt fully retract. To refasten the seat belt, pull it out only as far as needed.

## Automatic Seat Belt Tensioners

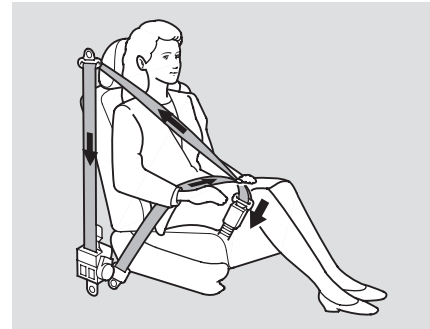

For added protection, the front seat belts are equipped with automatic seat belt tensioners. When activated, the tensioners immediately tighten the belts to help hold the driver and a front passenger in place.

CONTINUED

## Additional Information About Your Seat Belts

---

The tensioners are designed to activate in any collision severe enough to cause the front airbags to deploy.

If a side airbag or side curtain airbag deploys during a side impact, the tensioner on that side of the vehicle will also deploy.

The tensioners can also be activated during a collision in which the front airbags *do not deploy*. In this case, the airbags would not be needed, but the additional restraint could be helpful.

When the tensioners are activated, the seat belts will remain tight until they are unbuckled in the normal manner.

If the front seat belt tensioners ever activate, they must be replaced as the belts will no longer retract properly.

### Seat Belt Maintenance

For safety, you should check the condition of your seat belts regularly.

Pull each belt out fully, and look for frays, cuts, burns, and wear. Check that the latches work smoothly and the belts retract easily. If a belt does not retract easily, cleaning the belt may correct the problem (see page [237](#)). Any belt that is not in good condition or working properly will not provide good protection and should be replaced as soon as possible.

Honda provides a lifetime warranty on seat belts for U.S. models. See your *Honda Warranty Information* booklet for details.

If a seat belt is worn during a crash, it must be replaced by your dealer. A belt that has been worn during a crash may not provide the same level of protection in a subsequent crash.

The dealer should also inspect the anchors for damage and replace them if needed. If the automatic seat belt tensioners activate during a crash, they must be replaced.

### WARNING

Not checking or maintaining seat belts can result in serious injury or death if the seat belts do not work properly when needed.

Check your seat belts regularly, and have any problem corrected as soon as possible.

## Airbag System Components

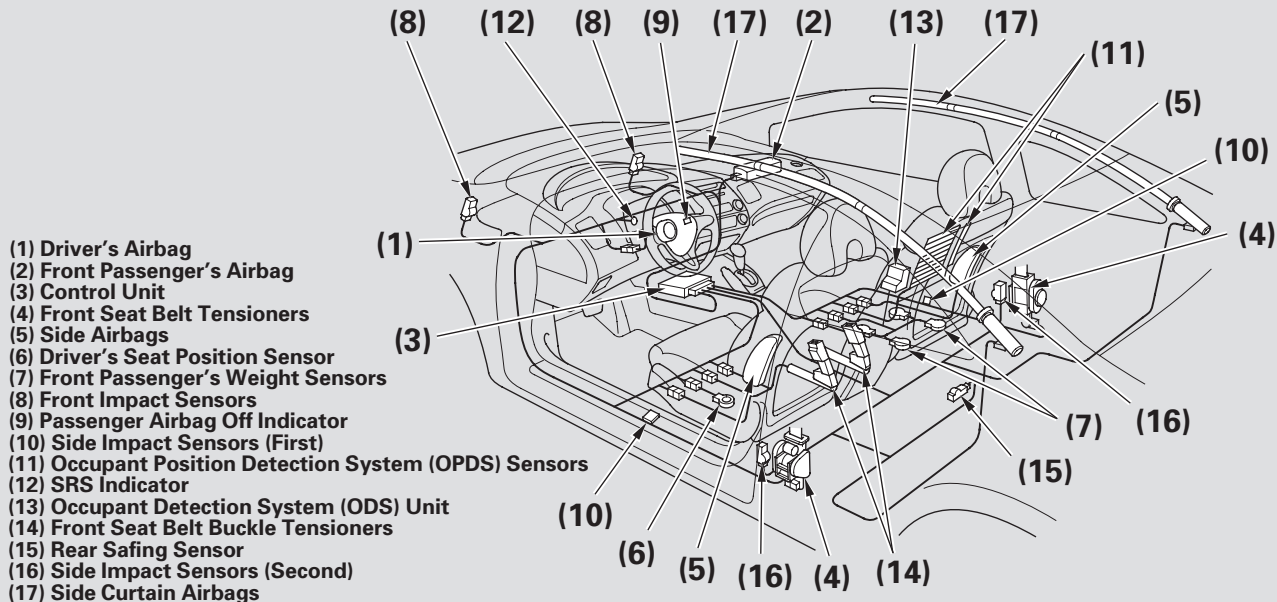

CONTINUED

## Additional Information About Your Airbags

---

Your airbag system includes:

- Two SRS (supplemental restraint system) front airbags. The driver's airbag is stored in the center of the steering wheel; the front passenger's airbag is stored in the dashboard. Both are marked "SRS AIRBAG" (see page 23).
- Two side airbags, one for the driver and one for a front passenger. The airbags are stored in the outer edges of the seat-backs. Both are marked "SIDE AIRBAG" (see page 26).
- Two side curtain airbags, one for each side of the vehicle. The airbags are stored in the ceiling, above the side windows. The front and rear pillars are marked "SIDE CURTAIN AIRBAG" (see page 28).
- Automatic front seat belt tensioners (see page 19).
- Sensors that can detect a moderate to severe front impact or side impact.
- Sensors that can detect whether a child is in the passenger's side airbag path and signal the control unit to turn the airbag off (see page 27).
- A driver's seat position sensor that monitors the distance of the seat from the front airbag. If the seat is too far forward, the airbag will inflate with less force (see page 25).
- Weight sensors that monitor the weight on the front passenger's seat. If the weight of an infant or small child is detected, the passenger's front airbag will be turned off (see page 25).
- A sophisticated electronic system that continually monitors and records information about the sensors, the control unit, the airbag activators, the seat belt tensioners, and driver and front passenger seat belt use when the ignition switch is in the ON (II) position.
- An indicator on the instrument panel that alerts you to a possible problem with your airbags, sensors, or seat belt tensioners (see page 28).
- An indicator on the instrument panel that alerts you that the passenger's side airbag has been turned off (see page 29).

- An indicator on the dashboard that alerts you that the passenger's front airbag has been turned off (see page 29).
- Emergency backup power in case your vehicle's electrical system is disconnected in a crash.

## How Your Front Airbags Work

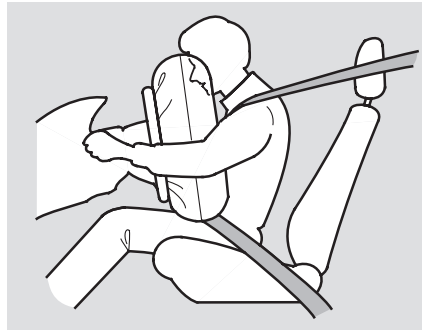

If you ever have a moderate to severe frontal collision, sensors will detect the vehicle's rapid deceleration.

If the rate of deceleration is high enough, the control unit will instantly inflate the driver's and front passenger's airbags, at the time and with the force needed.

During a frontal crash, your seat belt restrains your lower body and torso, and the front airbag helps protect your head and chest.

Although both airbags normally inflate within split second of each other, it is possible for only one airbag to deploy.

This can happen if the severity of a collision is at the margin, or threshold, that determines whether or not the airbags will deploy. In such cases, the seat belt will provide sufficient protection, and the supplemental protection offered by the airbag would be minimal.

Only the driver's airbag will deploy if there is no passenger in the front seat, or if the advanced airbag system has turned the passenger's airbag off (see page 25).

*CONTINUED*



## Additional Information About Your Airbags

---

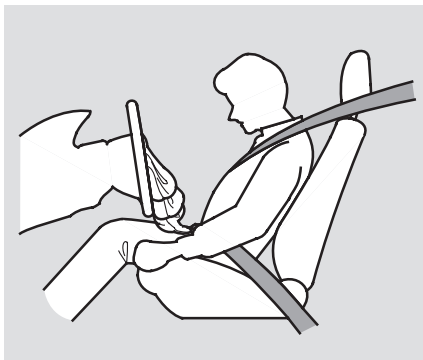

After inflating, the front airbags immediately deflate, so they won't interfere with the driver's visibility, or the ability to steer or operate other controls.

The total time for inflation and deflation is one-tenth of a second, so fast that most occupants are not aware that the airbags deployed until they see them lying in their laps.

After a crash, you may see what looks like smoke. This is actually powder from the airbag's surface. Although the powder is not harmful, people with respiratory problems may experience some temporary discomfort. If this occurs, get out of the vehicle as soon as it is safe to do so.

### *Dual-Stage Airbags*

Your front airbags are dual-stage airbags. This means they have two inflation stages that can be ignited sequentially or simultaneously, depending on crash severity.

In a *more severe* crash, both stages will ignite simultaneously to provide the quickest and greatest protection.

In a *less severe* crash, one stage will ignite first, then the second stage will ignite a split second later. This provides longer airbag inflation time with a little less force.

### *Dual-Threshold Airbags*

Your front airbags are also dual-threshold airbags. Airbags with this feature have two deployment thresholds that depend on whether or not the occupant is wearing a seat belt.

If the occupant's belt is *not latched*, the airbag will deploy at a slightly lower threshold, because the occupant would need extra protection.

If the occupant's belt *is latched*, the airbag will inflate at a slightly higher threshold, when the airbag would be needed to supplement the protection provided by the seat belt.

### ***Advanced Airbags***

Your front airbags are also advanced airbags. The main purpose of this feature is to help prevent airbag-caused injuries to short drivers and children who ride in front.

For both advanced airbags to work properly:

- Occupants must sit upright and wear their seat belts properly.
- Do not spill any liquids on or under the seats, cover the sensors, or put any cargo or metal objects under the front seats.
- Back-seat passengers should not put their feet under the front seats.

Failure to follow these instructions could damage the sensors or prevent them from working properly.

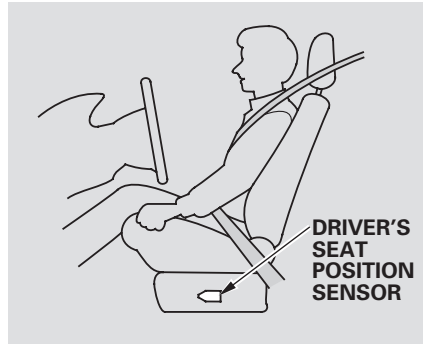

The driver's advanced front airbag system includes a seat position sensor under the seat. If the seat is too far forward, the airbag will inflate with less force, regardless of the severity of the impact.

If there is a problem with the sensor, the SRS Indicator will come on, and the airbag will inflate in the normal manner regardless of the driver's seating position.

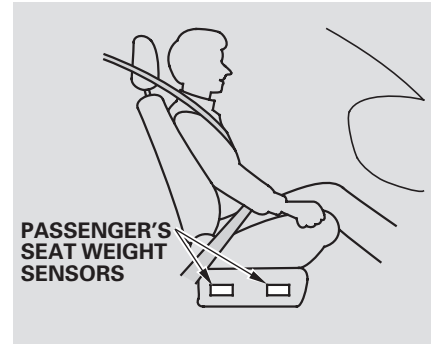

The passenger's advanced front airbag system has weight sensors under the seat. Although Honda does not encourage carrying an infant or small child in the front, if the sensors detect the weight of an infant or small child, the system will automatically turn the passenger's front airbag off.

CONTINUED

## Additional Information About Your Airbags

When the airbag is turned off, an indicator in the center of the dashboard will come on indicating passenger airbag “OFF” (see page 29 ).

If the weight sensors detect there is no passenger in the front seat, the airbag will be off. However, the passenger airbag off indicator will not come on.

To ensure that the passenger’s advanced front airbag system will work properly, ***do not do anything that would increase or decrease the weight on the front passenger’s seat.*** This includes:

- A rear passenger pushing or pulling on the back of the front passenger’s seat.

- Moving the front seat forcibly back against cargo on the seat or floor behind it.
- Moving the front seat forcibly back on the folded rear seat.
- The rear seat-back interfering with the reclined front passenger’s seat-back when the rear seat is folded down.
- Hanging heavy items on the front passenger seat, or placing heavy items in the seat-back pocket.

If your vehicle is equipped with the floor mats, make sure the floor mat behind the front passenger’s seat is hooked to the floor mat anchor (see page 238 ). If it is not, the mat may interfere with the proper operation of the sensors and operation of the seat.

### How Your Side Airbags Work

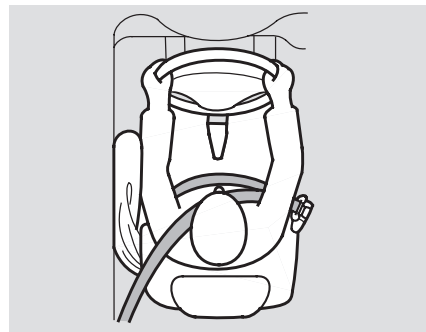

If you ever have a moderate to severe side impact, sensors will detect rapid deceleration and signal the control unit to instantly inflate either the driver’s or the passenger’s side airbag.

Only one airbag will deploy during a side impact. If the impact is on the passenger's side, the passenger's side airbag will deploy even if there is no passenger.

To get the best protection from the side airbags, front seat occupants should wear their seat belts and sit upright and well back in their seats.

### *Side Airbag Cutoff System*

Your vehicle has a side airbag cutoff system designed primarily to protect a child riding in the front passenger's seat.

Although Honda does not encourage children to ride in front, if sensors in the seat detect a child has leaned into the side airbag's deployment path, the airbag will shut off.

The side airbag may also shut off if a short adult leans sideways, or a larger adult slouches and leans sideways into the airbag's deployment path.

Objects placed on the front passenger seat can also cause the side airbag to be shut off.

If the side airbag off indicator comes on (see page 29), have the passenger sit upright. Once the passenger is out of the airbag's deployment path, the system will turn the airbag back on, and the indicator will go out.

There will be some delay between the moment the passenger moves into or out of the airbag deployment path and when the indicator comes on or goes off.

A front seat passenger should not use a cushion or other object as a backrest. It may prevent the cutoff system from working properly.

# Additional Information About Your Airbags

## How Your Side Curtain Airbags Work

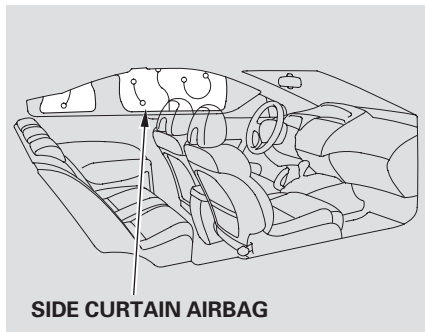

In a moderate to severe side impact, sensors will detect rapid deceleration and signal the control unit to instantly inflate the side curtain airbag on the driver's or the passenger's side of the vehicle.

If the impact is on the passenger's side, the passenger's side curtain airbag will inflate even if there are no occupants on that side of the vehicle.

To get the best protection from the side curtain airbags, occupants should wear their seat belts and sit upright and well back in their seats.

## How the SRS Indicator Works



The SRS indicator alerts you to a potential problem with your airbags or seat belt tensioners.

When you turn the ignition switch to the ON (II) position, this indicator comes on briefly then goes off. This tells you the system is working properly.

If the indicator comes on at any other time, or does not come on at all, you should have the system checked by your dealer. For example:

- If the SRS indicator does not come on after you turn the ignition switch to the ON (II) position.
- If the indicator stays on after the engine starts.
- If the indicator comes on or flashes on and off while you drive.

If you see any of these indications, the airbags and seat belt tensioners may not work properly when you need them.

## **⚠ WARNING**

Ignoring the SRS indicator can result in serious injury or death if the airbag systems or tensioners do not work properly.

Have your vehicle checked by a dealer as soon as possible if the SRS indicator alerts you to a possible problem.

### How the Side Airbag Off Indicator Works



This indicator alerts you that the passenger's side airbag has been automatically shut off. It does *not* mean there is a problem with your side airbags.

When you turn the ignition switch to the ON (II) position, the indicator should come on briefly and then go off (see page 58). If it doesn't come on, stays on, or comes on while driving without a passenger in the front seat, have the system checked.

### How the Passenger Airbag Off Indicator Works

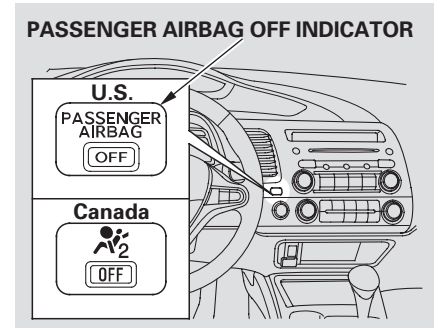

This indicator alerts you that the passenger's front airbag has been shut off because weight sensors detect an infant or small child may be in the front passenger's seat. It does *not* mean there is a problem with the airbag.

CONTINUED

## Additional Information About Your Airbags

---

If no one is riding in the front seat, the airbag will be automatically shut off. However, the indicator will not come on.

If the indicator comes on with no passenger in the front, or with an adult in the seat, there may be a problem with the advanced airbag system. Have the vehicle checked by your dealer as soon as possible.

The passenger airbag off indicator may also come on and off repeatedly if total weight on the seat is near the airbag cutoff threshold.

If this happens, have the passenger ride properly restrained in the back seat. If the passenger must ride in front, move the seat as far to the rear as possible, have the passenger sit upright and wear the seat belt properly.

### Airbag Service

Your airbag systems are virtually maintenance free, and there are no parts you can safely service. However, you must have your vehicle serviced if:

- ***An airbag ever inflates.*** Any airbag that has deployed must be replaced along with the control unit and other related parts. Any seat belt tensioner that activates must also be replaced.

Do not try to remove or replace any airbag by yourself. This must be done by your dealer or a knowledgeable body shop.

- ***The SRS indicator alerts you to a problem.*** Take your vehicle to an authorized dealer as soon as possible. If you ignore this indication, your airbags may not operate properly.
- ***If your vehicle has a moderate to severe impact.*** Even if your airbags do not inflate, your dealer should inspect the driver's seat position sensor, the front passenger's weight sensors, the front seat belt tensioners, and all seat belts worn during the crash to make sure they are operating properly.

### Additional Safety Precautions

- **Do not attempt to deactivate your airbags.** Together, airbags and seat belts provide the best protection.
- **Do not tamper with airbag components or wiring for any reason.** Tampering could cause the airbags to deploy, possibly causing very serious injury.
- **Do not remove or modify a front seat without consulting your dealer.** This could make the driver's seat position sensor or the front passenger's weight sensors ineffective. If it is necessary to remove or modify a front seat to accommodate a person with disabilities, first contact Honda Automobile Customer Service at (800) 999-1009.

- **Do not cover or replace front seat-back covers without consulting your dealer.** Improperly replacing or covering front seat-back covers can prevent your side airbags from inflating during a side impact.
- **Do not expose the front passenger's seat-back to liquid.** If water or another liquid soaks into the seat-back, it can prevent the side airbag cutoff system from working properly.

- **Do not recline the front passenger's seat-back as far to the rear as possible with the right rear seat folded down.** This will cause the front passenger's weight sensors to work improperly. The system may shut off the front passenger's airbag and the passenger airbag off indicator will come on. The seat belt reminder indicator for a front seat passenger may also work improperly.

Make sure that the folded-down rear seat does not press the front passenger's seat-back. Check the passenger airbag off indicator to confirm that the passenger's advanced front airbag is operating properly.



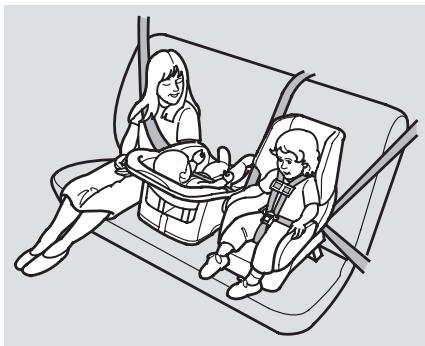

Children depend on adults to protect them. However, despite their best intentions, many adults do not know how to *properly* protect child passengers.

If you have children, or ever need to drive with a child in your vehicle, be sure to read this section. It begins with important general guidelines, then presents special information for infants, small children, and larger children.

**All Children Must Be Restrained**  
Each year, many children are injured or killed in vehicle crashes because they are either unrestrained or not properly restrained. In fact, vehicle accidents are the number one cause of the death of children ages 12 and under.

To reduce the number of child deaths and injuries, every state and Canadian province requires that infants and children be properly restrained when they ride in a vehicle.

*Infants and small children must be restrained in an approved child seat that is properly secured to the vehicle (see pages 37 – 45).*

### **⚠ WARNING**

Children who are unrestrained or improperly restrained can be seriously injured or killed in a crash.

Any child too small for a seat belt should be properly restrained in a child seat. A larger child should be properly restrained with a seat belt and use a booster seat if necessary.

*Larger children must be restrained with a lap/shoulder belt and ride on a booster seat until the seat belt fits them properly (see pages 46 – 49).*

## All Children Should Sit in a Back Seat

According to accident statistics, children of all ages and sizes are safer when they are restrained in a back seat. The National Highway Traffic Safety Administration and Transport Canada recommend that all children age 12 and under be properly restrained in a back seat.

Children who ride in back are less likely to be injured by striking interior vehicle parts during a collision or hard braking. Also, children cannot be injured by an inflating front airbag when they ride in the back.

## The Passenger's Front Airbag Can Pose Serious Risks

Front airbags have been designed to help protect adults in a moderate to severe frontal collision. To do this, the passenger's front airbag is quite large, and it can inflate with enough force to cause very serious injuries.

Even though your vehicle has an advanced front airbag system that automatically turns the passenger's front airbag off (see page 25), please follow these guidelines:

### *Infants*

***Never put a rear-facing child seat in the front seat of a vehicle equipped with a passenger's front airbag.*** If the airbag inflates, it can hit the back of the child seat with enough force to kill or very seriously injure an infant.

### *Small Children*

***Placing a forward-facing child seat in the front seat of a vehicle equipped with a passenger's front airbag can be hazardous.*** If the vehicle seat is too far forward, or the child's head is thrown forward during a collision, an inflating front airbag can strike the child with enough force to kill or very seriously injure a small child.

### *Larger Children*

***Children who have outgrown child seats are also at risk of being injured or killed by an inflating passenger's front airbag.*** Whenever possible, larger children should sit in the back seat, on a booster seat if needed, and be properly restrained with a seat belt (see page 46 for important information about protecting larger children).

CONTINUED

# Protecting Children – General Guidelines

To remind you of the passenger's front airbag hazards, and that children must be properly restrained in a back seat, your vehicle has warning labels on the dashboard (U.S. models) and on the front visors. Please read and follow the instructions on these labels.

## U.S. Models

### SUN VISOR



## Canadian Models

### SUN VISOR

#### CAUTION

##### TO AVOID SERIOUS INJURY:

- FOR MAXIMUM SAFETY PROTECTION IN ALL TYPES OF CRASHES, YOU MUST ALWAYS WEAR YOUR SAFETY BELT.
- DO NOT INSTALL REARWARD-FACING CHILD SEATS IN ANY FRONT PASSENGER SEAT POSITION.
- DO NOT SIT OR LEAN UNNECESSARILY CLOSE TO THE AIR BAG.
- DO NOT PLACE ANY OBJECTS OVER THE AIR BAG OR BETWEEN THE AIR BAG AND YOURSELF.
- SEE THE OWNER'S MANUAL FOR FURTHER INFORMATION AND EXPLANATIONS.

## DASHBOARD

This Vehicle is Equipped with  
Advanced Air Bags

### Even with Advanced Air Bags

- Children can be killed or seriously injured by the air bag.
- The back seat is the safest place for children.
- Never put a rear-facing child seat in the front.
- Always use seat belts and child restraints.
- See owner's manual for more information about air bags.

To be removed by owner only.

## If You Must Drive with Several Children

Your vehicle has a back seat where children can be properly restrained. If you ever have to carry a group of children, and a child must ride in front:

- Place the largest child in the front seat, provided the child is large enough to wear the lap/shoulder belt properly (see page 46).
- Move the vehicle seat as far to the rear as possible (see page 90).
- Have the child sit upright and well back in the seat (see page 15).
- Make sure the seat belt is properly positioned and secured (see page 14).

## If a Child Requires Close Attention

Many parents say they prefer to put an infant or small child in the front passenger seat so they can watch the child, or because the child requires attention.

Placing a child in the front seat exposes the child to hazards in a frontal collision, and paying close attention to a child distracts the driver from the important tasks of driving, placing both of you at risk.

If a child requires close physical attention or frequent visual contact, we strongly recommend that another adult ride with the child in the back seat. The back seat is far safer for a child than the front.

## Additional Safety Precautions

- **Never hold an infant or child on your lap.** If you are not wearing a seat belt in a crash, you could be thrown forward and crush the child against the dashboard or a seat-back. If you are wearing a seat belt, the child can be torn from your arms and be seriously hurt or killed.
- **Never put a seat belt over yourself and a child.** During a crash, the belt could press deep into the child and cause serious or fatal injuries.
- **Never let two children use the same seat belt.** If they do, they could be very seriously injured in a crash.

CONTINUED

## Protecting Children – General Guidelines

---

- ***Do not leave children alone in a vehicle.*** Leaving children without adult supervision is illegal in most states and Canadian provinces, and can be very hazardous.

For example, infants and small children left in a vehicle on a hot day can die from heatstroke. A child left alone with the key in the ignition switch can accidentally set the vehicle in motion, possibly injuring themselves or others.

- ***Lock both doors and the trunk when your vehicle is not in use.*** Children who play in vehicles can accidentally get trapped inside. Teach your children not to play in or around vehicles. Know how to operate the emergency trunk opener and decide if your children should be shown how to use this feature (see page [89](#) ).

- ***Keep vehicle keys/remote transmitters out of the reach of children.*** Even very young children learn how to unlock vehicle doors, turn on the ignition switch, and open the trunk, which can lead to accidental injury or death.

## Protecting Infants

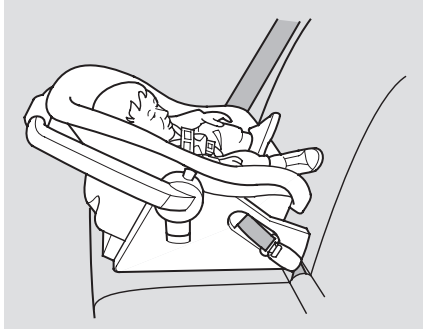

### *Child Seat Type*

An infant must be properly restrained in a rear-facing, reclining child seat until the child reaches the seat maker's weight or height limit for the seat and the child is at least one year old.

Only a rear-facing child seat provides proper support for a baby's head, neck, and back.

Two types of seats may be used: a seat designed exclusively for infants, or a convertible seat used in the rear-facing, reclining mode.

***Do not put a rear-facing child seat in a forward-facing position.*** If placed facing forward, an infant could be very seriously injured during a frontal collision.

### *Rear-facing Child Seat Placement*

A rear-facing child seat can be placed in any seating position in the back seat, but not in the front. ***Never put a rear-facing child seat in the front seat.***

If the passenger's front airbag inflates, it can hit the back of the child seat with enough force to kill or seriously injure an infant.

When properly installed, a rear-facing child seat may prevent the driver or a front passenger from moving their seat as far back as recommended, or from locking their seat-back in the desired position.

Or, it can interfere with proper operation of the passenger's advanced front airbag system.

CONTINUED

# Protecting Infants and Small Children

In any of these situations, we strongly recommend that you install the child seat directly behind the front passenger's seat, move the seat as far forward as needed, and leave it unoccupied. Or, you may wish to get a smaller rear-facing child seat.

## **⚠ WARNING**

Placing a rear-facing child seat in the front seat can result in serious injury or death during a collision.

Always place a rear-facing child seat in the back seat, not the front.

## Protecting Small Children



### *Child Seat Type*

A child who is at least one year old, and who fits within the child seat maker's weight and height limits, should be restrained in a forward-facing, upright child seat.

Of the different seats available, we recommend those that have a five-point harness system as shown.

We also recommend that a small child use the child seat until the child reaches the weight or height limit for the seat.

### *Child Seat Placement*

We strongly recommend placing a forward-facing child seat in a back seat, not the front.

*Placing a forward-facing child seat in the front seat of a vehicle equipped with a passenger's airbag can be hazardous.* If the vehicle seat is too far forward, or the child's head is thrown forward during a collision, an inflating airbag can strike the child with enough force to cause very serious or fatal injuries.

Even with advanced front airbags that automatically turn the passenger's front airbag off (see page 25), a back seat is the safest place for a small child.

If it is necessary to put a forward-facing child seat in the front, move the vehicle seat as far to the rear as possible, and be sure the child seat is firmly secured to the vehicle and the child is properly strapped in the seat.

## WARNING

Placing a forward-facing child seat in the front seat can result in serious injury or death if the front airbag inflates.

If you must place a forward-facing child seat in front, move the vehicle seat as far back as possible, and properly restrain the child.

## Selecting a Child Seat

When buying a child seat, you need to choose either a conventional child seat, or one designed for use with the lower anchors and tethers for children (LATCH) system.

Conventional child seats must be secured to a vehicle with a seat belt, whereas LATCH-compatible seats are secured by attaching the seat to hardware built into the two outer seating positions in the back seat.

Since LATCH-compatible child seats are easier to install and reduce the possibility of improper installation, we recommend selecting this style.

We also recommend selecting a LATCH-compatible seat with a rigid, rather than a flexible, anchor (see page 41).

In seating positions and vehicles not equipped with LATCH, a LATCH-compatible child seat can be installed using a seat belt.

Whatever type of seat you choose, to provide proper protection, a child seat should meet three requirements:

- 1. The child seat should meet U.S. or Canadian Motor Vehicle Safety Standard 213.* Look for FMVSS 213 or CMVSS 213 on the box.
- 2. The child seat should be of the proper type and size to fit the child.* Rear-facing for infants, forward-facing for small children.

CONTINUED



# Selecting a Child Seat, Installing a Child Seat

---

### ***3. The child seat should fit the vehicle seating position (or positions) where it will be used.***

Before purchasing a conventional child seat, or using a previously purchased one, we recommend that you test the seat in the specific vehicle seating position or positions where the seat will be used.

### **Installing a Child Seat**

After selecting a proper child seat and a good place to install the seat, there are three main steps in installing the seat:

***1. Properly secure the child seat to the vehicle.*** All child seats must be secured to the vehicle with the lap part of a lap/shoulder belt or with the LATCH (lower anchors and tethers for children) system. A child whose seat is not properly secured to the vehicle can be endangered in a crash.

***2. Make sure the child seat is firmly secured.*** After installing a child seat, push and pull the seat forward and from side-to-side to verify that it is secure.

A child seat secured with a seat belt should be installed as firmly as possible. However, it does not need to be “rock solid.” Some side-to-side

movement can be expected and should not reduce the child seat’s effectiveness.

If the child seat is not secure, try installing it in a different seating position, or use a different style of child seat that can be firmly secured.

***3. Secure the child in the child seat.*** Make sure the child is properly strapped in the child seat according to the child seat maker’s instructions. A child who is not properly secured in a child seat can be seriously injured in a crash.

The following pages provide guidelines on how to properly install a child seat. A forward-facing child seat is used in all examples, but the instructions are the same for rear-facing child seats.

## Installing a Child Seat with LATCH

Your vehicle is equipped with LATCH (lower anchors and tethers for children) at the outer rear seats.

The lower anchors are located between the seat-back and seat bottom, and are to be used only with a child seat designed for use with LATCH.

The location of each lower anchor is indicated by a small button above the anchor point.

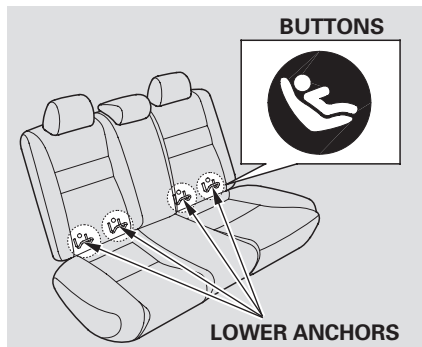

To install a LATCH-compatible child seat:

1. Move the seat belt buckle or tongue away from the lower anchors.
2. Make sure there are no objects near the anchors that could prevent a secure connection between the child seat and the anchors.

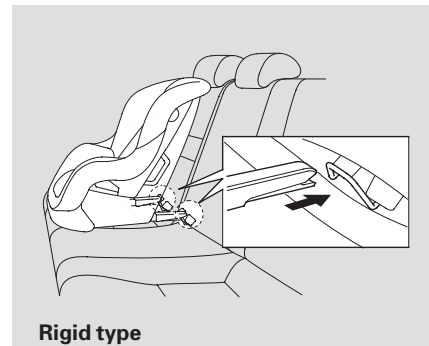

3. Place the child seat on the vehicle seat, then attach the seat to the lower anchors according to the child seat maker's instructions.

Some LATCH-compatible seats have a rigid-type connector as shown above.

CONTINUED

# Installing a Child Seat

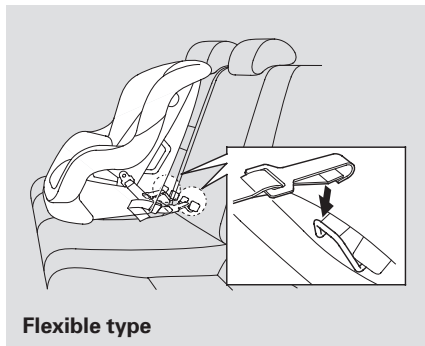

Other LATCH-compatible seats have a flexible-type connector as shown above.

4. Whatever type you have, follow the child seat maker's instructions for adjusting or tightening the fit.

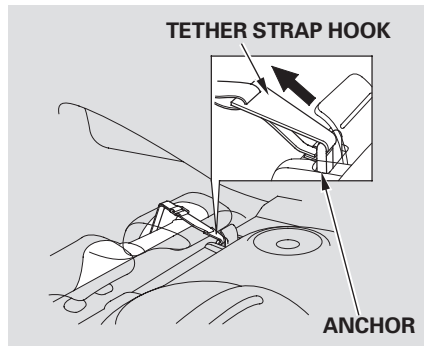

5. Adjust the head restraint to its lowest position. Route the tether strap over the head restraint, making sure the strap is not twisted.

6. Attach the tether strap hook to the tether anchor, then tighten the strap as instructed by the child seat maker.
7. Push and pull the child seat forward and from side-to-side to verify that it is secure.

These labels are in the locations shown. They warn you of potential hazards that could cause serious injury. Read these labels carefully.

If a label comes off or becomes hard to read (except for the U.S. dashboard label which may be removed by the owner), contact your dealer for a replacement.

## RADIATOR CAP

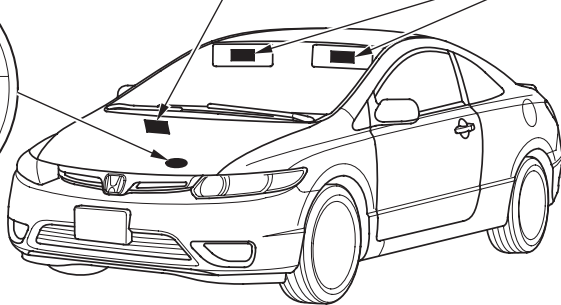

## DASHBOARD

*U.S. models only*

This Vehicle is Equipped with Advanced Air Bags

Even with Advanced Air Bags

Children can be killed or seriously injured by the air bag. The back seat is the safest place for children. Never put a rear-facing child seat in the front. Always use seat belts and child restraints. See owner's manual for more information about air bags.

To be removed by owner only.

## SUN VISOR

*U.S. models*



**AIR BAG WARNING**

*FLIP VISOR OVER*

**WARNING**

**EVEN WITH ADVANCED AIR BAGS**



- Children can be killed or seriously injured by the air bag
- The back seat is the safest place for children
- Never put a rear-facing child seat in the front
- Always use seat belts and child restraints
- See owner's manual for more information about air bags

## Canadian models

### CAUTION

- TO AVOID SERIOUS INJURY: FOR MAXIMUM SAFETY PROTECTION IN ALL TYPES OF CRASHES, YOU MUST ALWAYS WEAR YOUR SAFETY BELT.
- DO NOT INSTALL REARWARD-FACING CHILD SEATS IN ANY FRONT PASSENGER SEAT POSITION.
- DO NOT SIT OR LEAN UNNECESSARILY CLOSE TO THE AIR BAG.
- DO NOT PLACE ANY OBJECTS OVER THE AIR BAG OR BETWEEN THE AIR BAG AND YOURSELF.
- SEE THE OWNER'S MANUAL FOR FURTHER INFORMATION AND EXPLANATIONS.

### PRECAUTIONS:

- POUR ÉVITER DES BLESSURES GRAVES: POUR PROFITER D'UNE PROTECTION MAXIMALE LORS D'UNE COLLISION BOUCLEZ TOUJOURS VOTRE CEINTURE DE SÉCURITÉ.
- N'INSTALLEZ JAMAIS UN SIÈGE POUR ENFANTS FAISANT FACE À L'ARRIÈRE SUR LE SIÈGE DU PASSAGER AVANT.
- NE VOUS APPUYEZ PAS ET NE VOUS ASSOYEZ PAS PRES DU COUSSIN GONFLABLE.
- NE DEPOSEZ AUCUN OBJET SUR LE COUSSIN GONFLABLE ET VOUS.
- LISEZ LE GUIDE UTILISATEUR POUR DE PLUS AMPLES RENSEIGNEMENTS.

CONTINUED

# Safety Labels

## HOOD

*U.S. models*

### **▲ WARNING**

Accidental deployment can seriously hurt or kill you.  
Follow Service Manual instructions carefully.

*Canadian models*

### **▲ WARNING**

Accidental deployment can seriously hurt or kill you.  
Follow Service Manual instructions carefully.

### **▲ ATTENTION**

Un déploiement accidentel peut entraîner des blessures graves ou la mort.  
Suivre les instructions du manuel de réparation attentivement.

## DOORJAMBS

*U.S. models*

### SIDE AIRBAG

- This car is equipped with side airbags in the front seats and side curtain airbags.
- Do not lean against the door.
- See owner's manual for more information.

*Canadian models*

### SIDE AIRBAG

- This car is equipped with side airbags in the front seats and side curtain airbags.
- Do not lean against the door.
- See owner's manual for more information.

### COUSSIN GONFLABLE LATERAL

- Cette automobile est équipée de coussins gonflables latéraux dans les sièges avant ainsi que de coussins gonflables latéraux de type rideau.
- Ne vous appuyez pas sur la porte.
- Consultez le Manuel du propriétaire pour en savoir plus.

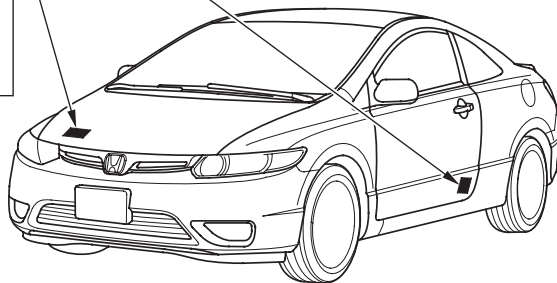

This section gives information about the controls and displays that contribute to the daily operation of your vehicle. All the essential controls are within easy reach.

Control Locations .....	54	Auto Door Locking/Unlocking..	78
Instrument Panel .....	55	Remote Transmitter .....	85
Instrument Panel Indicators.....	57	Trunk.....	88
Gauges .....	63	Emergency Trunk Opener .....	89
Display Change Button.....	64	Seats .....	90
Odometer.....	64	Power Windows .....	96
Trip Meter .....	64	Moonroof .....	98
Outside Temperature		Mirrors.....	100
Indicator.....	65	Parking Brake .....	101
Fuel Gauge .....	66	Interior Convenience Items.....	102
Temperature Gauge.....	66	Beverage Holders.....	103
Check Fuel Cap Indicator.....	66	Console Compartment.....	103
Maintenance Minder.....	67	Glove Box .....	103
Controls Near the Steering		Coat Hook.....	104
Wheel.....	68	Accessory Power Sockets.....	104
Windshield Wipers and Washers ..	69	Vanity Mirror .....	105
Turn Signal and Headlights.....	70	Sun Visor .....	105
Instrument Panel Brightness .....	71	Interior Lights .....	106
Hazard Warning Button.....	72	Ceiling Light.....	106
Rear Window Defogger .....	72	Spotlights .....	106
Steering Wheel Adjustments .....	73	Courtesy Light .....	107
Keys and Locks.....	74		
Immobilizer System.....	75		
Ignition Switch .....	76		
Door Locks .....	77		
Power Door Locks.....	78		

# Control Locations

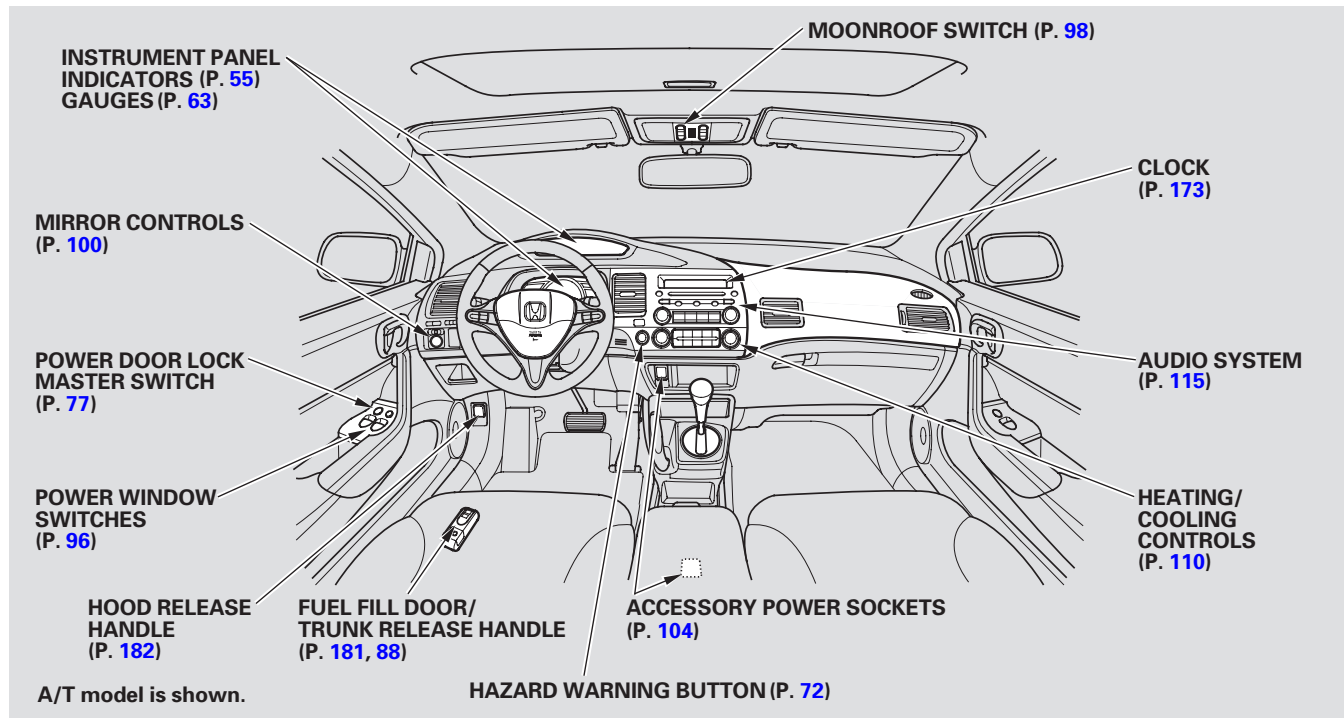

DX, DX-G (Canada), LX, EX

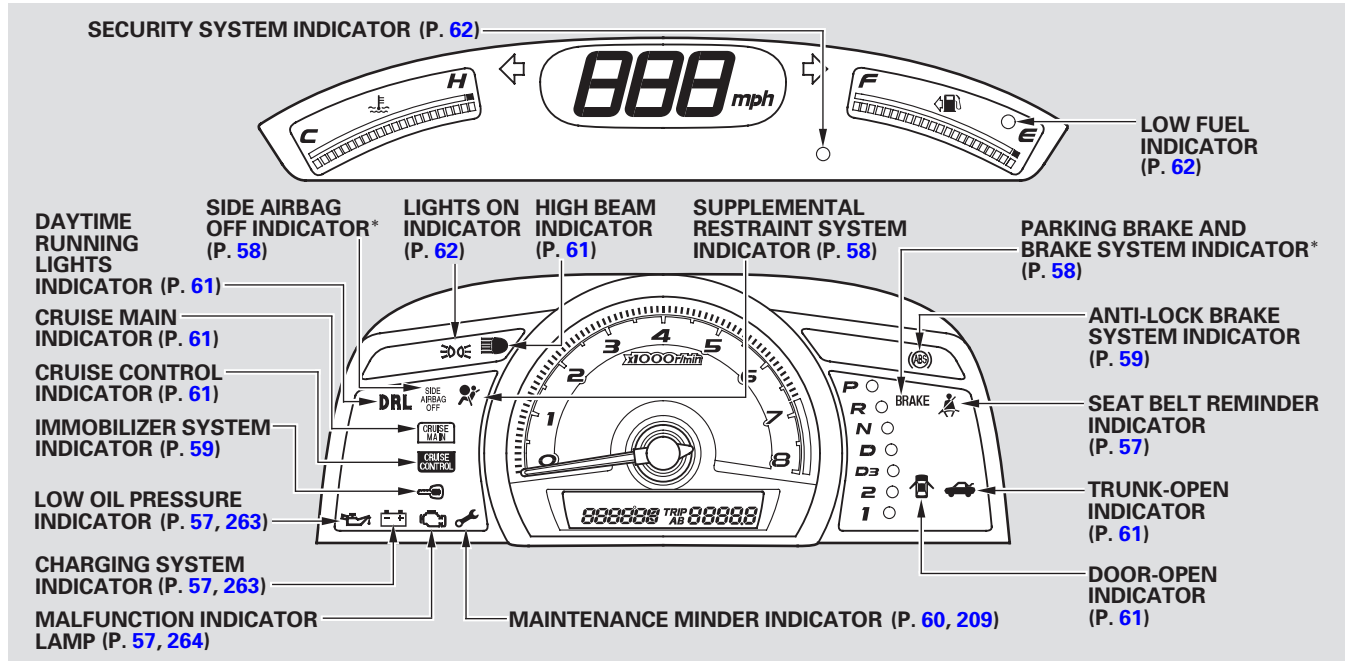

Instruments and Controls

\*: The U.S. instrument panel is shown. Differences for Canadian models are noted in the text.

CONTINUED



# Instrument Panel

Si

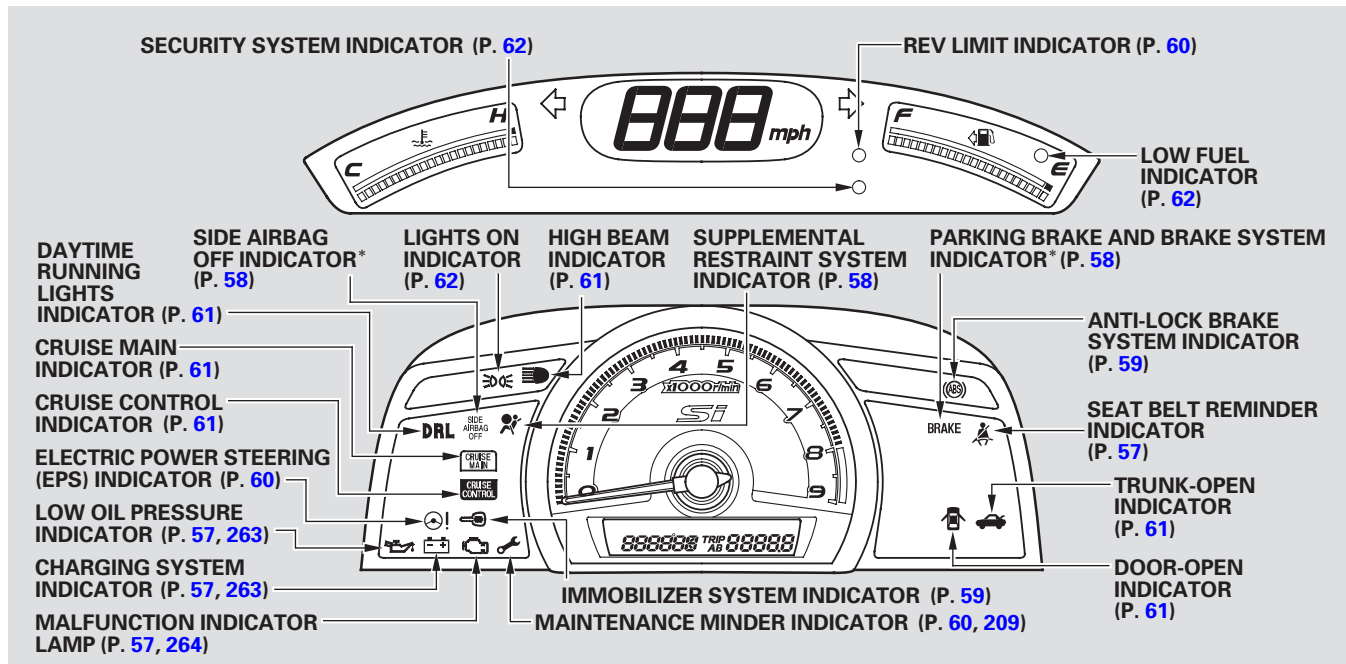

\*: The U.S. instrument panel is shown. Differences for Canadian models are noted in the text.

The instrument panel has many indicators to give you important information about your vehicle.



## Seat Belt Reminder Indicator

This indicator comes on when you turn the ignition switch to the ON (II) position. It reminds you and your passengers to fasten your seat belts. A beeper also sounds if you have not fastened your seat belt.

If you turn the ignition switch to the ON (II) position before fastening your seat belt, the beeper sounds and the indicator flashes. If you do not fasten your seat belt before the beeper stops, the indicator stops flashing but remains on.

If your front passenger does not fasten their seat belt, the indicator comes on about 6 seconds after the ignition switch is turned to the ON (II) position.

If either of you do not fasten your seat belt while driving, the beeper will sound and the indicator will flash again at regular intervals. For more information, see page 18 .



## Charging System Indicator

If this indicator comes on when the engine is running, the battery is not being charged. For more information, see page 263 .



## Low Oil Pressure Indicator

The engine can be severely damaged if this indicator flashes or stays on when the engine is running. For more information, see page 263 .



## Malfunction Indicator Lamp

See page 264 .

# Instrument Panel Indicators

U.S. Canada

BRAKE



## Parking Brake and Brake System Indicator

This indicator has two functions:

1. It comes on when you turn the ignition switch to the ON (II) position. It is a reminder to check the parking brake. A beeper sounds if you try to drive with the parking brake not fully released. Driving with the parking brake not fully released can damage the brakes and tires.
2. If it stays on after you have fully released the parking brake while the engine is running, or if it comes on while driving, there could be a problem with the brake system. For more information, see page [265](#).



## Supplemental Restraint System Indicator

This indicator comes on briefly when you turn the ignition switch to the ON (II) position. If it comes on at any other time, it indicates a potential problem with your front airbags. This indicator will also alert you to a potential problem with your side airbags, passenger's side airbag automatic cutoff system, side curtain airbags, automatic seat belt tensioners, driver's seat position sensor, or the front passenger's weight sensors. For more information, see page [28](#).

U.S. Canada

SIDE AIRBAG OFF



## Side Airbag Off Indicator

This indicator comes on when you turn the ignition switch to the ON (II) position. If it comes on at any other time, it indicates that the passenger's side airbag has automatically shut off. For more information, see page [29](#).



## Anti-lock Brake System (ABS) Indicator

This indicator normally comes on for a few seconds when you turn the ignition switch to the ON (II) position. If it comes on at any other time, there is a problem with the ABS. If this happens, have your vehicle checked at a dealer. With this indicator on, your vehicle still has normal braking ability but no anti-lock function. For more information, see page [204](#).



## Immobilizer System Indicator

This indicator comes on briefly when you turn the ignition switch to the ON (II) position. It will then go off if you have inserted a properly-coded ignition key. If it is not a properly-coded key, the indicator will blink, and the engine's fuel system will be disabled (see page [75](#)).



## Turn Signal and Hazard Warning Indicators

The left or right turn signal indicator blinks when you signal a lane change or turn. If an indicator does not blink or blinks rapidly, it usually means one of the turn signal bulbs is burned out (see page [235](#)). Replace the bulb as soon as possible, since other drivers cannot see that you are signaling.

When you press the hazard warning button, both turn signal indicators and all turn signals on the outside of the vehicle flash.

# Instrument Panel Indicators

## **Electric Power Steering (EPS) Indicator**

### *Si model only*

This indicator normally comes on when you turn the ignition switch to the ON (II) position and goes off after the engine starts. If it comes on at any other time, there is a problem in the electric power steering system. If this happens, stop the vehicle in a safe place, and turn off the engine. Reset the system by restarting the engine. The indicator will not turn off immediately. If it does not go off after driving a short distance, or comes back on again while driving, take the vehicle to your dealer to have it checked. With the indicator on, the EPS may be off, making the vehicle harder to steer.

If you turn the steering wheel to the full left or right repeatedly while stopping or driving at very low speed, you may feel slightly harder steering due to overheating of the steering gear box.

Continuously driving under those conditions could damage the power steering system.

## **Maintenance Minder Indicator**

This indicator reminds you that it is time to take your vehicle in for scheduled maintenance. The maintenance main items and sub items will be displayed in the information display. See page 209 for more information on the maintenance minder.

This indicator goes off when your dealer resets it after completing the required maintenance service.

## **Rev Limit Indicator**

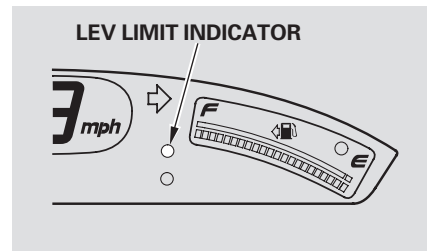

### *Si model only*

This indicator shows you when the engine speed is near the tachometer's red zone. When the engine speed gets to near the red zone, the indicator blinks. If you exceed the maximum speed for the gear you are in, the indicator stays on, and you may feel the engine cut in and out due to the engine speed limiter (see page 197).

To protect the engine from damage, never drive with the tachometer in its red zone.

**DRL****“Daytime Running Lights” Indicator**

If this indicator comes on when you turn the ignition switch to the ON (II) position and release the parking brake, it means there is a problem with the DRL. There may also be a problem with the high beam headlights. Have your vehicle checked by your dealer.

**High Beam Indicator**

This indicator comes on with the high beam headlights. For more information, see page [70](#) .

This indicator also comes on with reduced brightness when the daytime running lights (DRL) are on (see page [71](#) ).

**CRUISE  
MAIN****Cruise Main Indicator**

*If equipped*

This indicator comes on when you turn on the cruise control system by pressing the CRUISE button (see page [175](#) ).

**CRUISE  
CONTROL****Cruise Control Indicator**

*If equipped*

This indicator comes on when you set the cruise control. See page [175](#) for information on operating the cruise control.

**Washer Level Indicator**

*Canadian models only*

This indicator comes on when the washer fluid level is low. Add washer fluid when you see this indicator (see page [227](#) ).

**Trunk-open Indicator**

This indicator comes on if the trunk lid is not closed tightly.



**Door-open Indicator**

This indicator comes on if either door is not closed tightly.

# Instrument Panel Indicators



## Lights On Indicator

This indicator reminds you that the exterior lights are on. It comes on when the light switch is in either the  or  position. If you turn the ignition switch to the ACCESSORY (I) or LOCK (0) position without turning off the light switch, this indicator will stay on. A reminder beeper will also sound when you open the driver's door.

## Security System Indicator

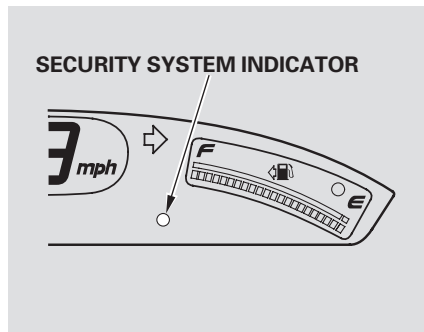

### *If equipped*

This indicator comes on when the security system is set. See page [174](#) for more information on the security system.

## Low Fuel Indicator

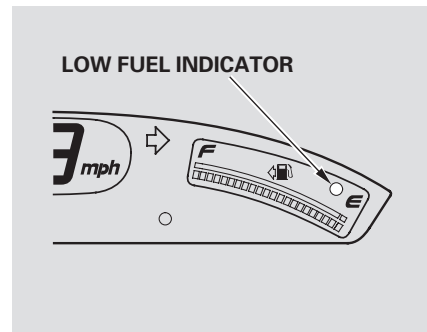

This indicator is located in the fuel gauge. It comes on as a reminder that you must refuel soon.

When the indicator comes on, there is about 1.9 US gal (7.5 l) of fuel remaining in the tank before the reading reaches E. There is a small reserve of fuel remaining in the tank when the reading does reach E.

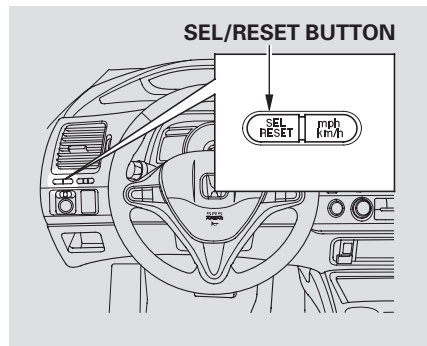
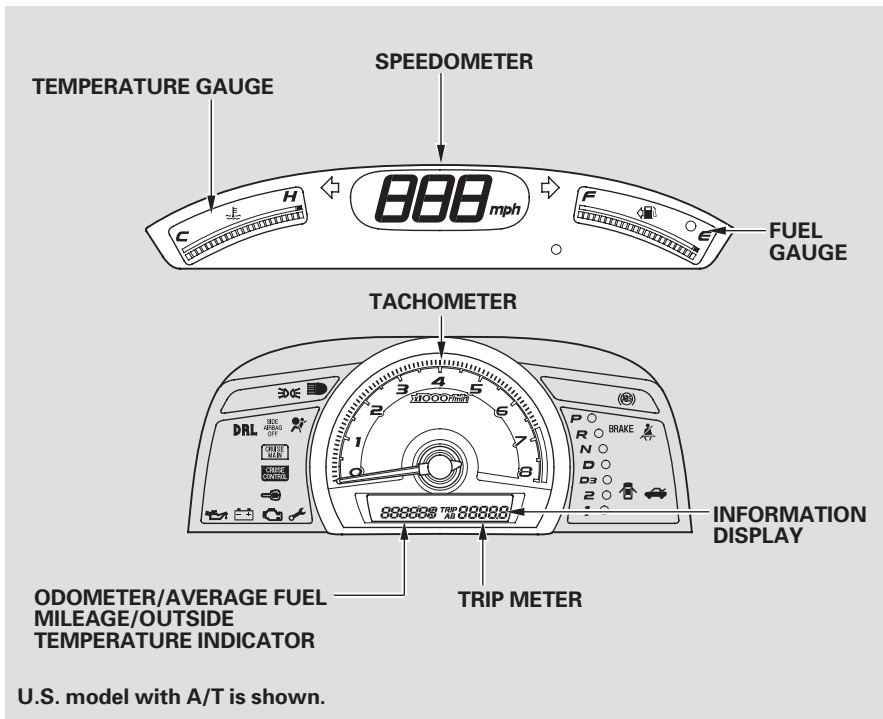

To switch the information display between the odometer, trip meter, and outside temperature (if equipped), and engine oil life and maintenance service items, press the SEL/RESET button repeatedly.



## Display Change Button

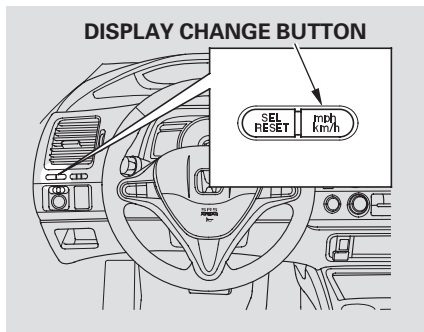

Press and hold the display change button until you hear a beep. The speedmeter, trip meter, and odometer readings switch between miles per hour (mph) and kilometers per hour (km/h).

## Odometer

This shows the total distance your vehicle has been driven. It measures miles or kilometers. It is illegal under U.S. federal law and Canadian provincial regulations to disconnect, reset, or alter the odometer with the intent to change the number of miles or kilometers indicated.

The odometer and the outside temperature indicator (if equipped) use the same display. To switch the display between them, press the SEL/RESET button repeatedly. When you turn the ignition switch to the ON (II) position, your last selection is displayed.

## Trip Meter

This meter shows the number of miles or kilometers driven since you last reset it.

There are two trip meters: Trip A and Trip B. Switch between these displays by pressing the SEL/RESET button repeatedly. Each trip meter works independently, so you can keep track of two different distances.

When you turn the ignition switch to the ON (II) position, what you last selected is displayed.

To reset a trip meter, display it, and then press and hold the SEL/RESET button until the number resets to "0.0."

### Outside Temperature Indicator *If equipped*

This indicator displays the outside temperature in Fahrenheit (U.S. models) or Centigrade (Canadian models). To see the outside temperature, press and release the SEL/RESET button until the temperature is shown on the information display.

The temperature sensor is in the front bumper. Therefore, the temperature reading can be affected by heat reflection from the road surface, engine heat, and the exhaust from surrounding traffic. This can cause an incorrect temperature reading when your speed is under 19 mph (30 km/h).

The sensor delays the display update until it reaches the correct outside temperature. This may take several minutes.

If the outside temperature is incorrectly displayed, you can adjust it  $\pm 5^{\circ}\text{F}$  in U.S. models ( $\pm 3^{\circ}\text{C}$  in Canadian models) warmer or cooler.

**NOTE:** The temperature must be stabilized before doing this procedure.

Select the outside temperature display, then press the SEL/RESET button for 10 seconds. The following sequence will appear for 1 second each: 0, 1, 2, 3, 4, 5, -5, -4, -3, -2, -1, 0 (U.S.) or 0, 1, 2, 3, -3, -2, -1, 0 (Canada).

When it reaches the desired value, release the SEL/RESET button. You should see the new outside temperature displayed.

In certain weather conditions, temperature readings indicate near freezing ( $32^{\circ}\text{F}$ ,  $0^{\circ}\text{C}$ ) and the display starts blinking. This could mean that ice is forming on the road surface.

## Fuel Gauge

This shows how much fuel you have. It may show slightly more or less than the actual amount.

### NOTICE

*Avoid driving with an extremely low fuel level. Running out of fuel could cause the engine to misfire, damaging the catalytic converter.*

## Temperature Gauge

This shows the temperature of the engine's coolant. During normal operation, the reading should rise to about the middle of the gauge. In severe driving conditions, such as very hot weather or a long period of uphill driving, the reading may rise into the upper half of the gauge. If it reaches the red (Hot) mark, pull safely to the side of the road. See page [261](#) for instructions and precautions on checking the engine cooling system.

## Check Fuel Cap Indicator

If your fuel fill cap is loose or missing, a "CHECK FUEL CAP" message appears in the information display after you start the engine. The message goes from CHECK to FUEL, then to CAP repeatedly. You will also hear a beep.

Turn the engine off, and confirm the fuel fill cap is installed. If it is, loosen the cap, then retighten it until it clicks at least once. When you restart the engine, the message appears again. To clear the message, press and hold the SEL/RESET button until it goes away.

If the system still detects a loose or missing fuel fill cap, the malfunction indicator lamp (MIL) comes on. Turn the engine off, and check or retighten the fuel fill cap until it clicks at least once. The MIL goes out after several days of normal driving once the cap is tightened or replaced. If it does not go out, have your dealer inspect the vehicle. For more information, see page [264](#).

### **Maintenance Minder**

The information display in the instrument panel shows you the engine oil life and maintenance service items when the ignition switch is in the ON (II) position. This information helps to keep you aware of the periodic maintenance your vehicle needs for continued trouble-free driving. Refer to page [209](#) for more information.

# Controls Near the Steering Wheel

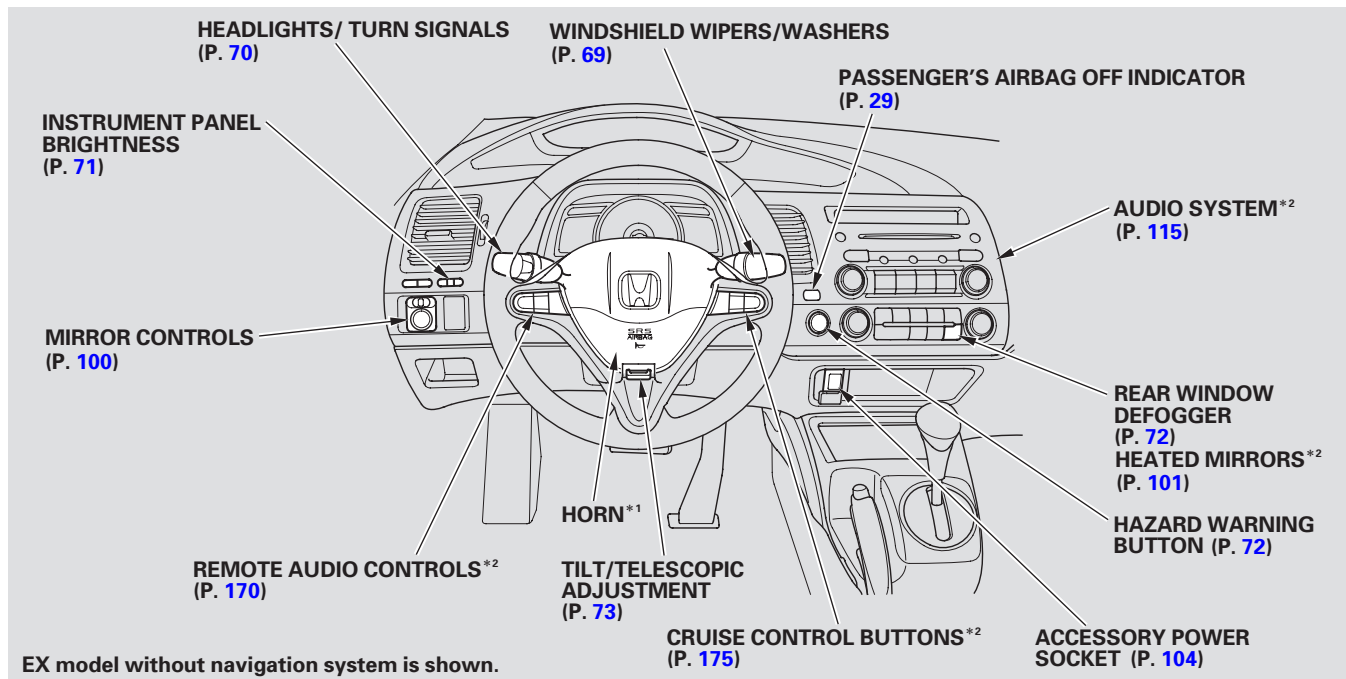

\* 1 To use the horn, press the center pad of the steering wheel.

\* 2 If equipped.

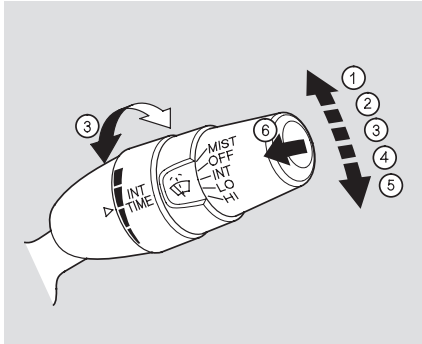

1. MIST
2. OFF
3. INT — Intermittent
4. LO — Low speed
5. HI — High speed
6. Windshield washers

Push the right lever up or down to select a position.

**MIST** — The wipers run at high speed until you release the lever.

**OFF** — The wipers are not activated.

**INT** — The wipers operate every few seconds. In low speed and high speed, the wipers run continuously.

*On EX and Si models in U.S., and LX, EX and Si models in Canada*  
The length of the wiper interval is varied automatically according to the vehicle's speed.

Vary the delay by turning the INT TIME ring. If you turn it to the shortest delay, the wipers change to low speed when the vehicle speed exceeds 12 mph (20km/h).

**LO** — The wipers run at low speed.

**HI** — The wipers run at high speed.

**Windshield Washer** — Pull the wiper control lever toward you, and hold it. The washers spray until you release the lever. The wipers run at low speed, then complete one more sweep after you release the lever.

# Turn Signal and Headlights

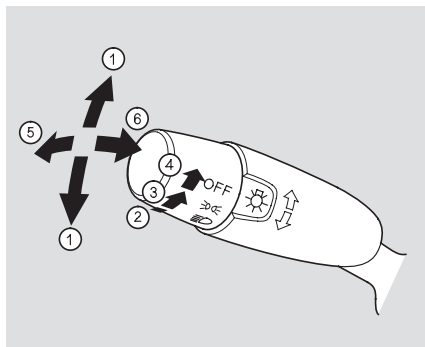



1. Turn signal
2. Off
3. Parking and indicator lights
4. Headlights on
5. High beams
6. Flash high beams

**Turn Signal** — Push down on the lever to signal a left turn and up to signal a right turn. To signal a lane change, push lightly on the lever, and hold it. The lever will return to center when you release it or complete a turn.

**Headlights On** — Turning the switch to the “ ” position turns on the parking lights, taillights, instrument panel lights, side-marker lights, and rear license plate lights.

Turning the switch to the “ ” position turns on the headlights. If you leave the lights on with the key removed from the ignition switch, you will hear a reminder beeper when you open the driver’s door.

When the light switch is in the “ ” or “ ” position, the lights on indicator comes on as a reminder.

**High Beams** — Push the lever forward until you hear a click to turn on the high beams. The blue high beam indicator will come on (see page 61). Pull the lever back to return to the low beams.

To flash the high beams, pull the lever back lightly, then release it. The high beams will stay on as long as you hold the lever back.

## Daytime Running Lights

With the headlight switch off or in the  $\text{☞☞☞}$  position, the high beam headlights and the high beam indicator come on with reduced brightness when you turn the ignition switch to the ON (II) position and release the parking brake. They remain on until you turn the ignition switch off, even if you set the parking brake.

The headlights revert to normal operation when you turn them on with the switch.

## Instrument Panel Brightness

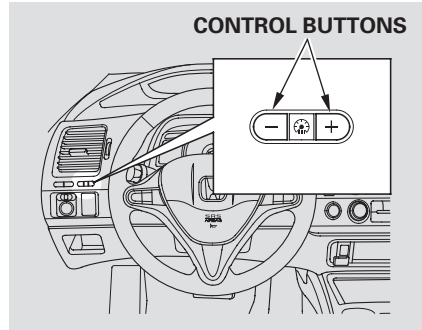

The buttons under the left side vent control the brightness of the instrument panel. Push the + or - button to adjust the brightness.

Separate adjustments can be made when the headlights are on and off.

There are six brightness levels. When you push either button, the information display indicates the current level. You will hear a tone

when you reach the maximum or minimum brightness. The display returns to the odometer 5 seconds after you stop adjusting the brightness.

To reduce glare at night, the instrument panel illumination dims when you turn the light switch to  $\text{☞☞☞}$  or  $\text{☞☞}$ .

The center of each meter (upper and lower) illuminates with reduced brightness when you unlock and open the driver's door, and then goes back to the selected brightness when you turn the ignition switch to the ON (II) position.

If you insert the key but do not turn the ignition switch to the ON (II) position, the illumination turns off in about 7 seconds.



# Hazard Warning Button, Rear Window Defogger

## Hazard Warning Button

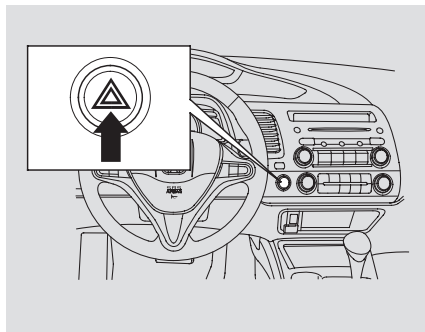

Push the button next to the steering wheel to turn on the hazard warning lights (four-way flashers). This causes all four outside turn signals and both turn indicators in the instrument panel to flash. Use the hazard warning lights if you need to park in a dangerous area near heavy traffic, or if your vehicle is disabled.

## Rear Window Defogger

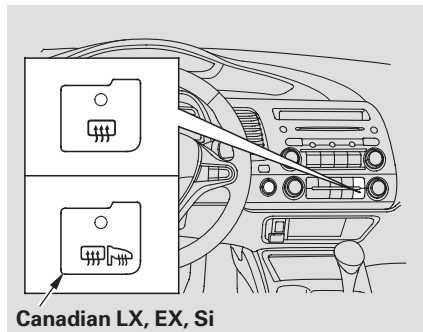

The rear window defogger will clear fog, frost, and thin ice from the window. Push the defogger button to turn it on and off. The indicator in the button comes on to show the defogger is on. If you do not turn it off, the defogger will shut itself off after about 15 minutes. It also shuts off when you turn off the ignition switch. You have to turn the defogger on again when you restart the vehicle.

Make sure the rear window is clear and you have good visibility before starting to drive.

The defogger and antenna wires on the inside of the rear window can be accidentally damaged. When cleaning the glass, always wipe side-to-side.

*On Canadian LX, EX and Si models*  
Pushing this button also turns the mirror heaters on or off. For more information, see page [101](#).

Make any steering wheel adjustments before you start driving.

## **⚠ WARNING**

Adjusting the steering wheel position while driving may cause you to lose control of the vehicle and be seriously injured in a crash.

Adjust the steering wheel only when the vehicle is stopped.

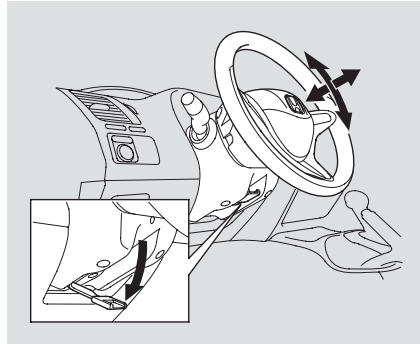

1. Push the lever under the steering column all the way down.
2. Move the steering wheel so it points toward your chest, not toward your face. Make sure you can see the instrument panel gauges and indicators.

3. Push the lever up to lock the steering wheel in position.
4. Make sure you have securely locked the steering wheel in place by trying to move it up, down, in, and out.

# Keys and Locks

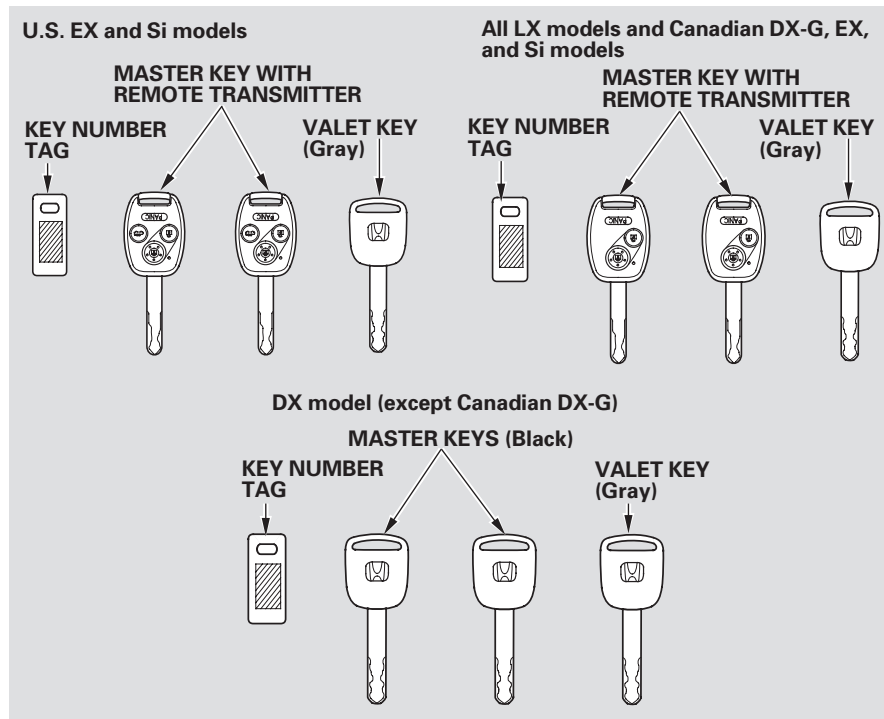

The master key fits all the locks on your vehicle. The valet key works only in the ignition and the driver's door lock\*. You can keep the trunk and trunk release handle locked when you leave your vehicle and the valet key at a parking facility.

\* On DX model (except Canadian DX-G), the passenger's door can also be locked or unlocked with the key.

You should have received a key number tag with your keys. You will need this key number if you ever have to get a lost key replaced. Use only Honda-approved key blanks.

These keys contain electronic circuits that are activated by the immobilizer system. They will not work to start the engine if the circuits are damaged.

- Protect the keys from direct sunlight, high temperature, and high humidity.
- Do not drop the keys or set heavy objects on them.
- Keep the keys away from liquids. If they get wet, dry them immediately with a soft cloth.

*On DX model (except Canadian DX-G)*

The keys do not contain batteries. Do not try to take them apart.

## Immobilizer System

The immobilizer system protects your vehicle from theft. If an improperly-coded key (or other device) is used, the engine's fuel system is disabled.

When you turn the ignition switch to the ON (II) position, the immobilizer system indicator should come on briefly, then go off. If the indicator starts to blink, it means the system does not recognize the coding of the key. Turn the ignition switch to the LOCK (0) position, remove the key, reinsert it, and turn the ignition switch to the ON (II) position again.

The system may not recognize your key's coding if another immobilizer key or other metal object (i.e. key fob) is near the ignition switch when you insert the key.

If the system repeatedly does not recognize the coding of your key, contact your dealer.

Do not attempt to alter this system or add other devices to it. Electrical problems could result that may make your vehicle undrivable.

If you have lost your key and cannot start your engine, contact your dealer.

CONTINUED

# Immobilizer System, Ignition Switch

*As required by the FCC:*

*This device complies with Part 15 of the FCC rules. Operation is subject to the following two conditions: (1) This device may not cause harmful interference, and (2) this device must accept any interference received, including interference that may cause undesired operation.*

*Changes or modifications not expressly approved by the party responsible for compliance could void the user's authority to operate the equipment.*

*This device complies with Industry Canada Standard RSS-210.*

*Operation is subject to the following two conditions: (1) this device may not cause interference, and (2) this device must accept any interference that may cause undesired operation of the device.*

## Ignition Switch

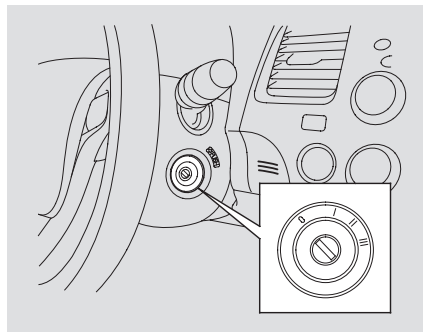

The ignition switch has four positions: **LOCK (0)**, **ACCESSORY (I)**, **ON (II)**, and **START (III)**.

**LOCK (0)** — You can insert or remove the key only in this position. To turn the key, push it in slightly. If your vehicle has an automatic transmission, the shift lever must also be in park.

If the front wheels are turned, the anti-theft lock may make it difficult to turn the key. Firmly turn the steering wheel to the left or right as you turn the key.

**ACCESSORY (I)** — You can operate the audio system and the accessory power socket in this position.

**ON (II)** — This is the normal key position when driving. Several of the indicators on the instrument panel come on as a test when you turn the ignition switch from the **ACCESSORY (I)** to the **ON (II)** position.

**START (III)** — Use this position only to start the engine. The switch returns to the **ON (II)** position when you let go of the key.

You will hear a reminder beeper if you leave the key in the LOCK (0) or the ACCESSORY (I) position and open the driver's door. Remove the key to turn off the beeper.

If your vehicle has an automatic transmission, the shift lever must be in Park before you can remove the key from the ignition switch.

## **⚠ WARNING**

Removing the key from the ignition switch while driving locks the steering. This can cause you to lose control of the vehicle.

Remove the key from the ignition switch only when parked.

## Door Locks

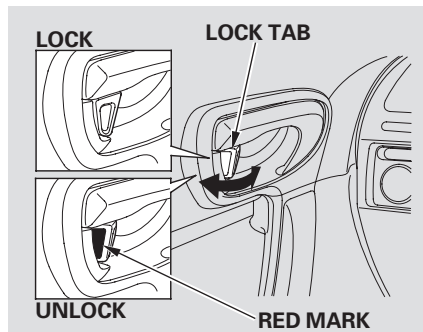

Each door has a lock tab next to the inside door handle. Pull out the tab to lock the door, and push it in to unlock.

When the door is unlocked, the red mark on the lock tab is shown.

*On DX model except Canadian DX-G*  
To lock the passenger's door when getting out of the vehicle, pull out the lock tab and close the door. To lock the driver's door, pull and hold the outside door handle then pull out the lock tab. Release the handle, then close the door.

Each door can be locked or unlocked with the ignition key.

# Door Locks

## Power Door Locks

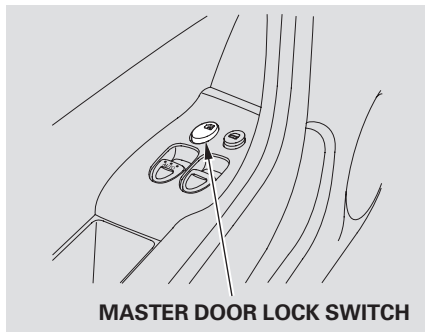

### *If equipped*

To lock the doors, push the top of the master door lock switch on either door, pull out the lock tab on the driver's door, or use the key in the outside lock on the driver's door.

Pushing the bottom of either master door lock switch unlocks both doors.

The lock tab on the passenger's door locks and unlocks only that door. Pushing in the driver's door lock tab only unlocks the driver's door. To unlock only the driver's door from the outside, turn the key and release it. If you turn it again, both doors unlock.

To lock the passenger's door when getting out of the vehicle, pull out the lock tab and close the door. To lock the driver's door, remove the key from the ignition switch and pull out the lock tab or push the top of the master switch, then close the door.

### *Lockout Prevention*

With the driver's door open and the key in the ignition, both master door lock switches are disabled. They are not disabled if the driver's door is closed. Pushing the top of the switch on the open passenger's door will lock both doors.

## **Auto Door Locking/Unlocking**

*On LX, EX, and Si model in the U.S., and DX-G, LX, EX, and Si models in Canada*  
Your vehicle has two custom door lock settings: auto door locking and auto driver's door unlocking. Make all settings before you start driving.

**Auto Door Locking**

The auto door locking feature has two or three possible settings, depending on the transmission type (A/T or M/T):

- The doors lock when the vehicle speed reaches 9 mph (15 km/h).
- On vehicles with automatic transmission, the doors lock whenever you move the shift lever out of the Park position.
- The auto door locking is deactivated all the time. This is the default setting when the vehicle leaves the factory.

**To activate either auto door lock mode:**

*Locks both doors when the vehicle's speed reaches about 9 mph (15 km/h).*

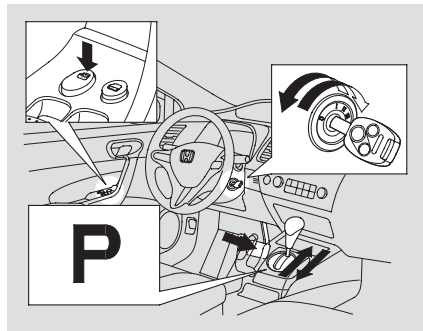

*On vehicles with automatic transmission*

1. Make sure the shift lever is in Park (P), and close the driver's door.
2. Turn the ignition switch to the ON (II) position.

3. Set the parking brake.

4. Push and hold the brake pedal, then move the shift lever out of Park (P).

5. Push and hold the front of the master door lock switch on the driver's door. You will hear a clicking sound, and after about 5 seconds, you will hear another clicking sound.

6. Release the switch, move the shift lever to Park (P), and turn the ignition switch to the LOCK (0) position within 5 seconds.

*On vehicles with manual transmission*

1. Close the driver's door.

2. Turn the ignition switch to the ON (II) position.

*CONTINUED*



# Door Locks

3. Set the parking brake.
4. Push and hold the front of the master door lock switch on the driver's door. You will hear a clicking sound, and after about 5 seconds, you will hear another clicking sound.
5. Release the switch, and turn the ignition switch to the LOCK (0) position within 5 seconds.

*Locks both doors when the shift lever is moved out of Park (P).  
On vehicles with automatic transmission only*

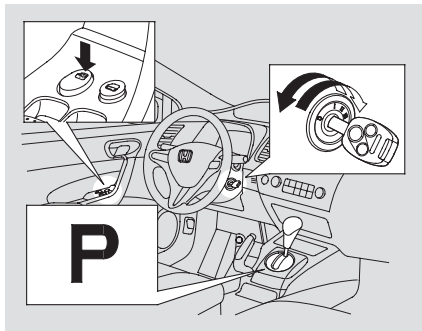

1. Make sure the shift lever is in Park (P), and close the driver's door.
2. Turn the ignition switch to the ON (II) position.
3. Set the parking brake.

4. Push and hold the front of the master door lock switch on the driver's door. You will hear a clicking sound, and after about 5 seconds, you will hear another clicking sound.
5. Release the switch, and turn the ignition switch to the LOCK (0) position within 5 seconds.

**To turn the auto door lock modes off:**

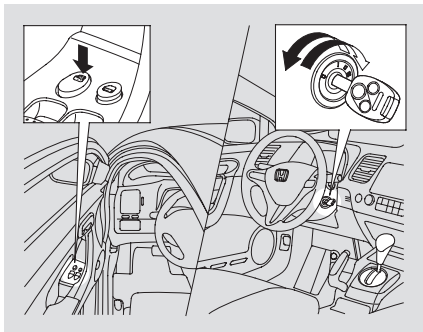

1. Open the driver's door.  
On vehicles with automatic transmission, make sure the shift lever is in Park (P).
2. Turn the ignition switch to the ON (II) position.
3. Set the parking brake.

4. Push and hold the front of the master door lock switch on the driver's door. You will hear a clicking sound, and after about 5 seconds, you will hear another clicking sound.
5. Release the switch, and turn the ignition switch to the LOCK (0) position within 5 seconds.

## Auto Door Unlocking

The auto door unlocking feature has two or three of these possible settings, depending on the transmission type (A/T or M/T):

- The driver's door unlocks whenever you turn the ignition switch to the LOCK (0) position.
- On vehicles with automatic transmission, the driver's door unlocks when you move the shift lever to the Park position.
- The auto door unlocking is deactivated all the time. This is the default setting when the vehicle leaves the factory.

CONTINUED

# Door Locks

## ***To activate either auto door unlock mode:***

*Unlocks the driver's door when the ignition switch is out of the ON (II) position.*

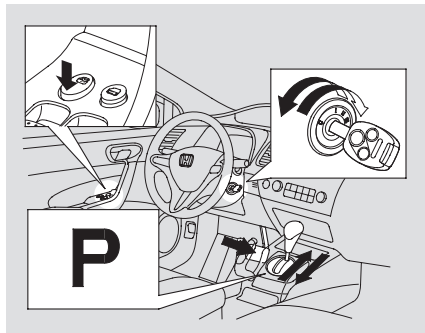

## ***On vehicles with automatic transmission***

1. Make sure the shift lever is in Park (P), and close the driver's door.
2. Turn the ignition switch to the ON (II) position.

3. Set the parking brake.
4. Push and hold the brake pedal, then move the shift lever out of Park (P).
5. Push and hold the rear of the master door lock switch on the driver's door. You will hear a clicking sound, and after about 5 seconds, you will hear another clicking sound.
6. Release the switch, move the shift lever to Park (P), and turn the ignition switch to the LOCK (0) position within 5 seconds.

## ***On vehicles with manual transmission***

1. Close the driver's door.
2. Turn the ignition switch to the ON (II) position.
3. Set the parking brake.
4. Push and hold the rear of the master door lock switch on the driver's door. You will hear a clicking sound, and after about 5 seconds, you will hear another clicking sound.
5. Release the switch, and turn the ignition switch to the LOCK (0) position within 5 seconds.

*Unlocks driver's door when the shift lever is moved to Park (P).*

*On vehicles with automatic transmission only*

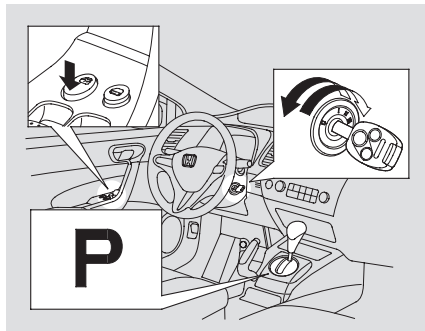

1. Make sure the shift lever is in Park (P), and close the driver's door.
2. Turn the ignition switch to the ON (II) position.
3. Set the parking brake.

4. Push and hold the rear of the master door lock switch on the driver's door. You will hear a clicking sound, and after about 5 seconds, you will hear another clicking sound.
5. Release the switch, and turn the ignition switch to the LOCK (0) position within 5 seconds.

*To turn the auto door unlock modes off:*

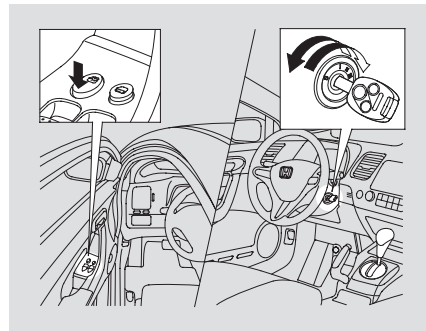

1. Open the driver's door.  
On vehicles with automatic transmission, make sure the shift lever is in Park (P).
2. Turn the ignition switch to the ON (II) position.
3. Set the parking brake.

*CONTINUED*

## Door Locks

---

4. Push and hold the rear of the master door lock switch on the driver's door. You will hear a clicking sound, and after about 5 seconds, you will hear another clicking sound.
5. Release the switch, and turn the ignition switch to the LOCK (0) position within 5 seconds.

Even though your vehicle's battery is removed or goes dead, the system keeps the auto door lock/unlock setting which you selected.

U.S.: LX Canada: DX-G, LX, EX, Si

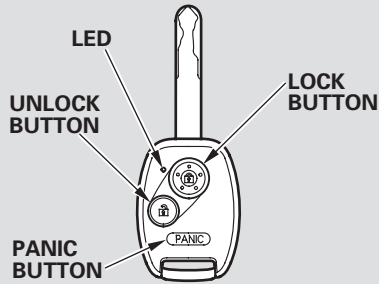

U.S.: LX, EX, Si

Canada: DX-G, LX, EX, Si

**LOCK** — Press this button once to lock both doors. Some exterior lights will flash once. When you push **LOCK** twice within 5 seconds, you will hear a beep to verify that the doors are locked and that the security system has set (on U.S. LX, EX and Si models). You cannot lock the doors if either door is not fully closed or the key is in the ignition switch.

U.S. EX and Si models

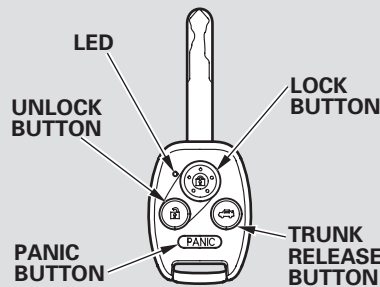

**UNLOCK** — Press this button once to unlock the driver's door. Push it twice to unlock the passenger's door. Some exterior lights will flash twice each time you push the button.

The ceiling light (if the ceiling light switch is in the center position) and the spotlights (if the switch is in the Door position on EX and Si models) will come on when you press the **UNLOCK** button. If you do not open either door within 30 seconds, the lights fade out. If you relock the doors with the remote transmitter before 30 seconds have elapsed, the lights go off immediately.

If you do not open either door within 30 seconds, the doors automatically relock, and the security system sets (on U.S. LX, EX, and Si models). You cannot unlock it if the key is in the ignition switch.

CONTINUED

# Remote Transmitter

*On U.S. EX and Si models*

**TRUNK RELEASE** — Press this button for about 1 second to open the trunk. You cannot open the trunk if the key is in the ignition switch.

**PANIC** — Press this button for about 2 seconds to attract attention: the horn will sound, and the exterior lights will flash for about 30 seconds. To cancel panic mode, press any other button on the remote transmitter, or turn the ignition switch to the ON (II) position.

## **Remote Transmitter Care**

- Avoid dropping or throwing the transmitter.
- Protect the transmitter from extreme temperature.
- Do not immerse the transmitter in any liquid.
- If you lose a transmitter, the replacement needs to be reprogrammed by your dealer.

## **Replacing the Transmitter Battery**

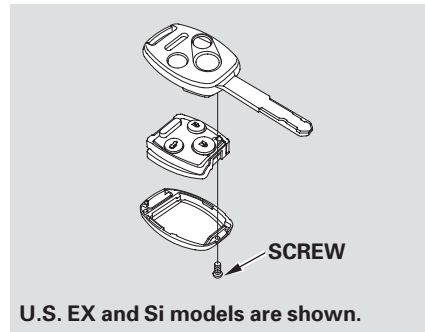

If it takes several pushes on the button to lock or unlock the doors, replace the battery as soon as possible.  
Battery type: CR1616

To replace the battery:

1. Remove the screw at the base of the transmitter with a small Phillips-head screwdriver.

2. Separate the transmitter by prying its middle seam with your fingernail.

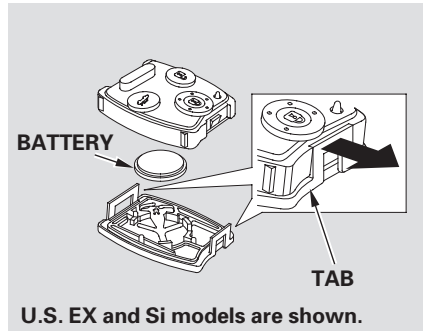

3. Inside the transmitter, separate the inner cover from the keypad by releasing the two tabs on the cover.

4. Remove the old battery from the back of the inner cover, and insert a new battery into the back of the cover with the + side facing down.
5. Install the parts in reverse order.

*As required by the FCC:*

*This device complies with Part 15 of the FCC rules. Operation is subject to the following two conditions: (1) This device may not cause harmful interference, and (2) this device must accept any interference received, including interference that may cause undesired operation.*

*Changes or modifications not expressly approved by the party responsible for compliance could void the user's authority to operate the equipment.*

*This device complies with Industry Canada Standard RSS-210.*

*Operation is subject to the following two conditions: (1) this device may not cause interference, and (2) this device must accept any interference that may cause undesired operation of the device.*



# Trunk

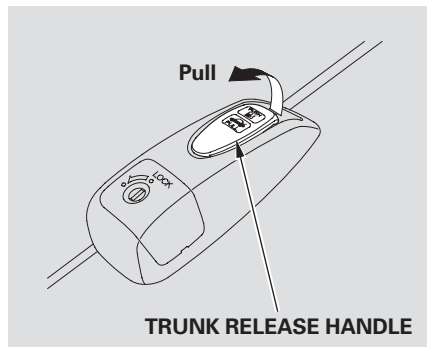

You can open the trunk in two ways:

- Pull the trunk release handle to the left of the driver's seat.
- *On all models except U.S. EX and Si*  
Use the master key to open the trunk lock. The valet key does not work in this lock.

- *On U.S. EX and Si models*  
Press and hold the trunk release button on the remote transmitter.

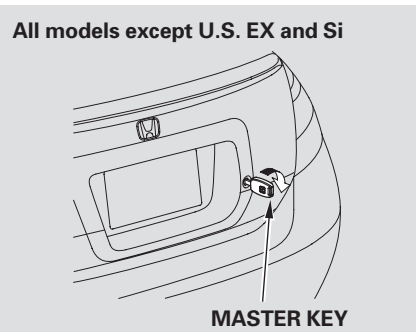

To close the trunk, press down on the trunk lid.

Keep the trunk lid closed at all times while driving to avoid damaging the lid, and to prevent exhaust gas from getting into the interior. See **Carbon Monoxide Hazard** on page 50 .

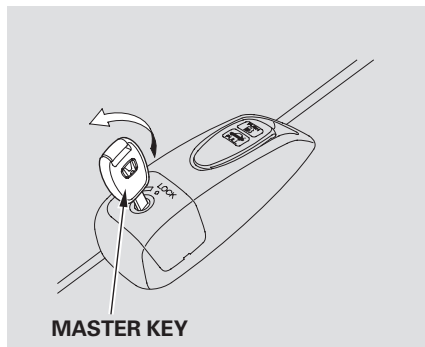

To protect items in the trunk when you need to give the key to someone else:

1. Lock the trunk release handle with the master key.
2. Give the person the valet key.

### Emergency Trunk Opener

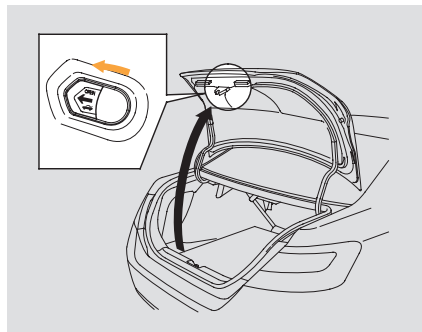

As a safety feature, your vehicle has a release lever on the trunk latch so the trunk can be opened from the inside. To open the trunk, push the release lever to the left.

Parents should decide if their children should be shown how to use this feature. For more information about child safety, see [page 35](#).

# Seats

## Front Seat Adjustments

See pages 11 – 13 for important safety information and warnings about how to properly position the seats and seat-backs.

Make all seat adjustments before you start driving.

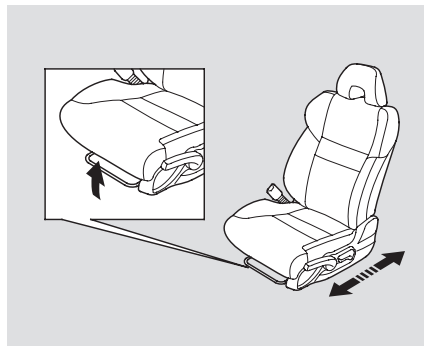

To adjust the seat forward or backward, pull up on the bar under the seat cushion's front edge. Move the seat to the desired position, and release the bar. Try to move the seat to make sure it is locked in position.

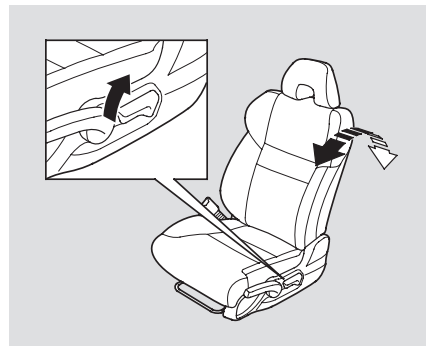

To change the seat-back angle, pull up on the lever on the outside of the seat bottom.

Once your seat is adjusted correctly, rock it back and forth to make sure it is locked in position.

### Driver's Seat Height Adjustment

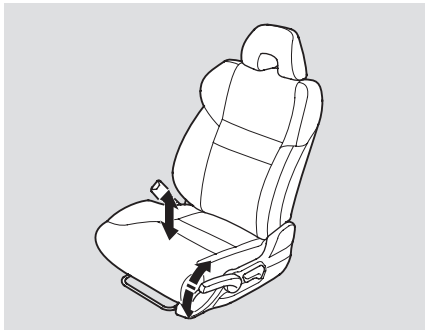

The height of your driver's seat is adjustable. To raise the seat bottom, repeatedly pull up the lever on the outside of the seat cushion. To lower the seat, push the lever down repeatedly.

Make all seat adjustments before you start driving.

### Armrest

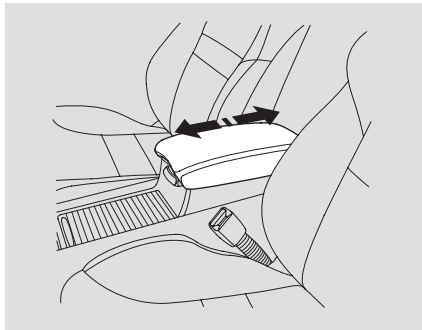

To use the console lid as an armrest, slide it to one of its three positions.

Make sure your passenger's hands or fingers are away from the armrest before moving it.

## Rear Seat Access

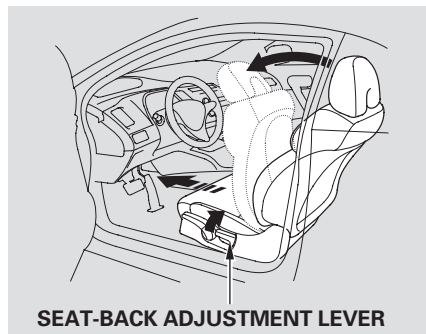

### *Driver's Side*

To get into the rear seat on the driver's side, open the door and pull up on the seat-back adjustment lever. The seat-back will tilt forward to allow easier entry to the rear seat.

### *Passenger's Side*

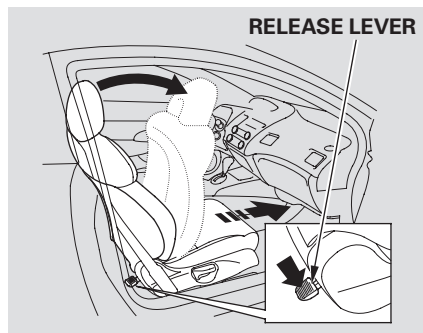

To get into the rear seat on the passenger's side, push downward on the release lever at the base of the seat-back or pull up on the seat-back adjustment lever. The seat-back will tilt forward, and the seat will move forward to allow easier entry to the rear seat.

*All models except DX and Canadian DX-G*

After a passenger gets into the back seat, push the seat-back to the upright position, and push the seat backwards until it latches. Make sure the seat is fully latched before sitting in it.

*On DX and Canadian DX-G models*

When you return the seat-back upright, the seat stays in the fully forward position. Use the seat adjustment bar and the seat-back adjustment lever to move the seat to the desired position. Make sure the seat is fully latched before sitting in it.

## Head Restraints

See page 13 for important safety information and a warning about how to properly position the head restraints.

Your vehicle is equipped with head restraints in all seating positions to help protect you and your passengers from whiplash and other injuries.

They are most effective when you adjust them so the back of the occupant's head rests against the center of the restraint.

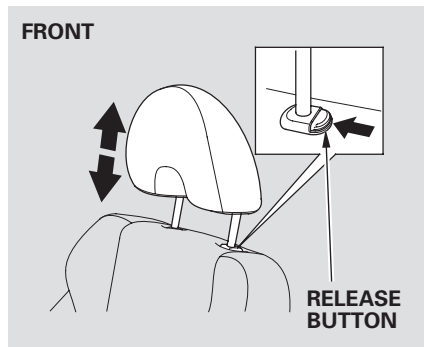

The head restraints adjust for height. You need both hands to adjust a restraint. Do not attempt to adjust it while driving. To raise it, pull upward. To lower the restraint, push the release button sideways, and push the restraint down.

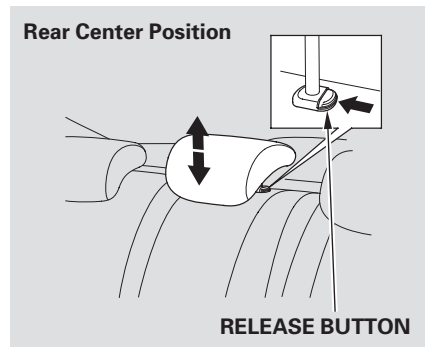

When carrying a passenger in the rear center seating position, make sure the rear center head restraint is adjusted to its highest position.

## Folding Rear Seat

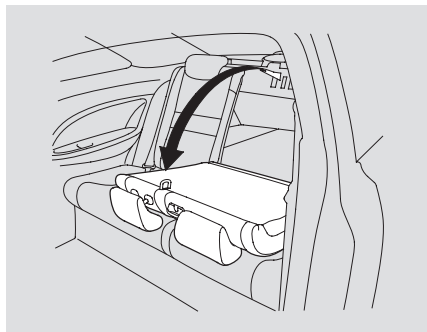

The back of the rear seat folds down to give you direct access to the trunk. The seat-back can be released from inside the trunk.

*On all models except DX and U.S. LX*  
The left and right halves can be folded separately.

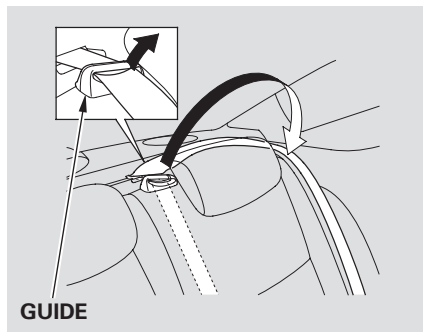

When storing cargo, you can move the rear center shoulder belt out of the way by removing the belt from the guide.

Remove any items from the seat before you fold down the seat-back.

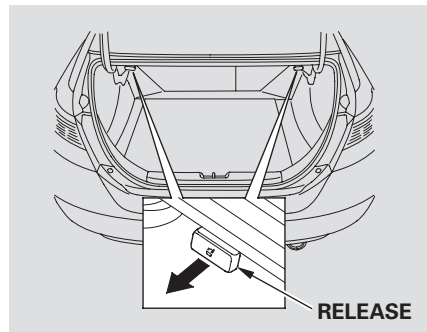

To release the seat-back, pull the release under the trunk panel. Push the seat-back down, then let go of the release.

For 60/40 split rear fold-down seat models, a release is located on each side of the trunk.

For full rear fold-down seat models, the release is located on the driver's side of the trunk.

Make sure that the folded-down rear seat does not interfere with the front passenger's seat-back. This will cause the front passenger's weight sensors to work improperly (see page 25 ). This may also cause the seat belt reminder indicator for a front passenger to work improperly. Also, check the passenger airbag off indicator to assure the proper operation of the passenger's advanced front airbag.

To lock the seat-back upright, push it firmly against the trunk panel. Make sure it is latched in place by pulling on the top of the seat.

Make sure all rear shoulder belts are positioned in front of the rear seat-back whenever it is in the upright position.

Do not put any heavy items on the seat-back when it is folded.

Make sure all items in the trunk, or items extending through the opening into the back seat, are secured. Loose items can fly forward and cause injury if you have to brake hard. See **Carrying Cargo** on page 188 .

Never drive with the seat-back folded down and the trunk lid open. See **Carbon Monoxide Hazard** on page 50 .



# Power Windows

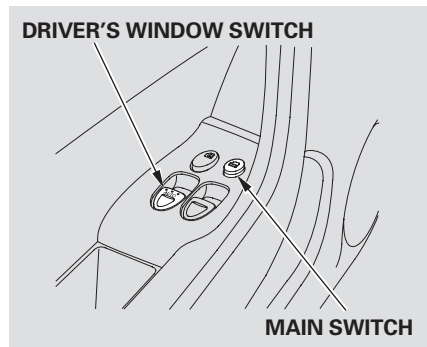

## *If equipped*

Turn the ignition switch to the ON (II) position to raise or lower either window. To open the window, push the switch down and hold it. Release the switch when you want the window to stop. Pull back on the switch and hold it to close the window.

The windows operate for up to 10 minutes after you turn off the ignition switch. Opening either door

cancels this function.

## **⚠ WARNING**

Closing a power window on someone's hands or fingers can cause serious injury.

Make sure your passengers are away from the windows before closing them.

The driver's armrest has a master power window control panel. To open the passenger's window, push down on the switch and hold it down until the window reaches the desired position. To close the window, pull back on the window switch. Release the switch when the window gets to the position you want.

**AUTO** — To open the driver's window fully, push the window switch firmly down, then release it. The window automatically goes down all the way. To stop the window from going all the way down, pull back on the window switch briefly.

To close the driver's window fully, pull back the window switch firmly, then release it. The window automatically goes all the way up. To stop the window from going all the way up, push down on the window switch briefly.

To open or close the driver's window partially, push down or pull back on the window switch lightly and hold it. The window will stop when you release the switch.

When you push the MAIN switch in, the switch is OFF, and the passenger's window cannot be raised or lowered. To cancel this feature, push on the switch again to get it to pop out. Keep the MAIN switch off when you have children in the vehicle so they do not injure themselves by operating the window unintentionally.

**AUTO REVERSE** — If the driver's window runs into any obstacle while it is closing automatically, it will reverse direction, and then stop. To close the window, remove the obstacle, then use the window switch again.

Auto reverse stops sensing when the window is almost closed. You should always check that all passengers and objects are away from the window before closing it.

If your vehicle's battery is disconnected or goes dead, or the driver's window fuse is removed, the AUTO function could be disabled. If the power window system needs to be reset after reconnecting the battery or installing the fuse, do this:

1. Start the engine. Push down and hold the driver's window switch until the window is fully open.
2. Pull and hold the driver's window switch to close the window completely, then hold the switch for about 2 seconds.

If the power windows do not operate properly after resetting, have your vehicle checked by your dealer.

# Moonroof

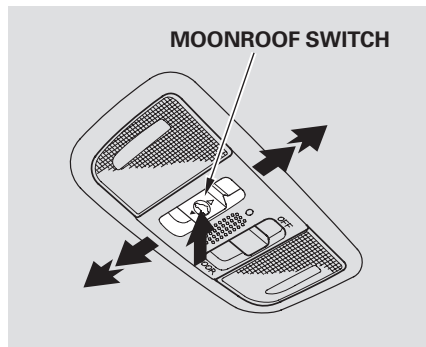

## *If equipped*

The moonroof can be tilted up in the back for ventilation, or it can be slid back into the roof. Use the switch on the front ceiling to operate the moonroof. You must turn the ignition switch to the ON (II) position to operate the moonroof.

To tilt up the back of the moonroof, push on the center of the moonroof switch. To stop the moonroof to tilt up fully, push the switch briefly.

To open the moonroof, pull back on the switch and hold it. Release the switch when the moonroof reaches the desired position. To close the moonroof, push the switch forward and hold it. Release the switch to stop the operation.

## **⚠ WARNING**

Opening or closing the moonroof on someone's hands or fingers can cause serious injury.

Make sure all hands and fingers are clear of the moonroof before opening or closing it.

**AUTO** — To open the moonroof fully, pull back the moonroof switch firmly, then release it. The moonroof automatically opens all the way. To stop the moonroof from opening, push the switch briefly.

To close the moonroof fully, firmly push the moonroof switch forward, then release it. The moonroof automatically closes all the way. To stop the moonroof from closing, push the switch briefly.

To open or close the moonroof partially, lightly pull the switch back or push it forward and hold it. The moonroof will stop when you release the switch.

**AUTO REVERSE** — If the moonroof runs into any obstacle while it is closing automatically, it will reverse direction and then stop. To close the moonroof, remove the obstacle, then use the moonroof switch again.

Auto reverse stops sensing when the moonroof is almost closed. You should always check that all passengers and objects are away from the moonroof before closing it.

The moonroof has a key-off delay. You can open and close the moonroof for up to 10 minutes after you turn off the ignition switch. The key-off delay cancels as soon as you open either door.

**NOTICE**

*If you try to open the moonroof in below-freezing temperatures, or when it is covered with snow or ice, you can damage the moonroof panel or motor.*

# Mirrors

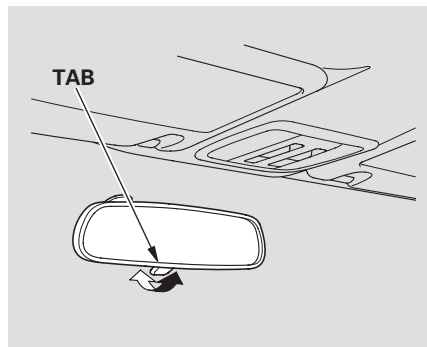

Keep the inside and outside mirrors clean and adjusted for best visibility. Be sure to adjust the mirrors before you start driving.

The inside mirror has day and night positions. The night position reduces glare from headlights behind you. Flip the tab on the bottom edge of the mirror to select the day or night position.

## Adjusting the Power Mirrors

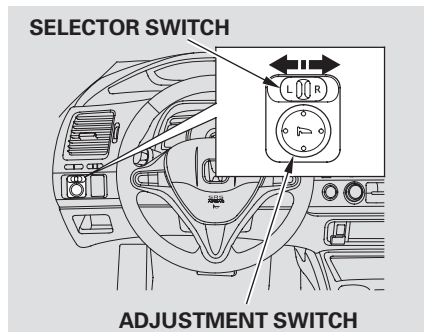

*If equipped*

1. Turn the ignition switch to the ON (II) position.
2. Move the selector switch to L (driver's side) or R (passenger's side).

3. Push the appropriate edge of the adjustment switch to move the mirror right, left, up, or down.
4. When you finish, move the selector switch to the center (off) position. This turns the adjustment switch off to keep your settings.

## Power Mirror Heaters

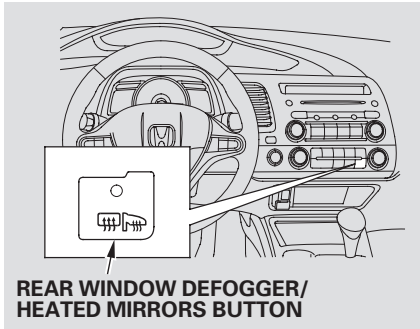

*On Canadian LX, EX and Si models*  
The outside mirrors are heated to remove fog and frost. With the ignition switch in the ON (II) position, turn on the heaters by pressing the rear window defogger button. The indicator in the button comes on as a reminder. Press the button again to turn the heaters and the defogger off.

## Parking Brake

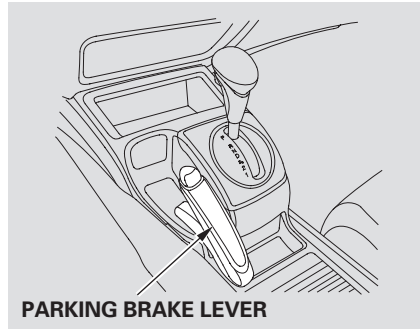

To apply the parking brake, pull the lever up fully. To release it, pull up slightly, push the button, and lower the lever. The parking brake indicator on the instrument panel should go out when the parking brake is fully released (see page 58).

## NOTICE

*Driving the vehicle with the parking brake applied can damage the rear brakes and axles. A beeper will sound if the vehicle is driven with the parking brake on.*

# Interior Convenience Items

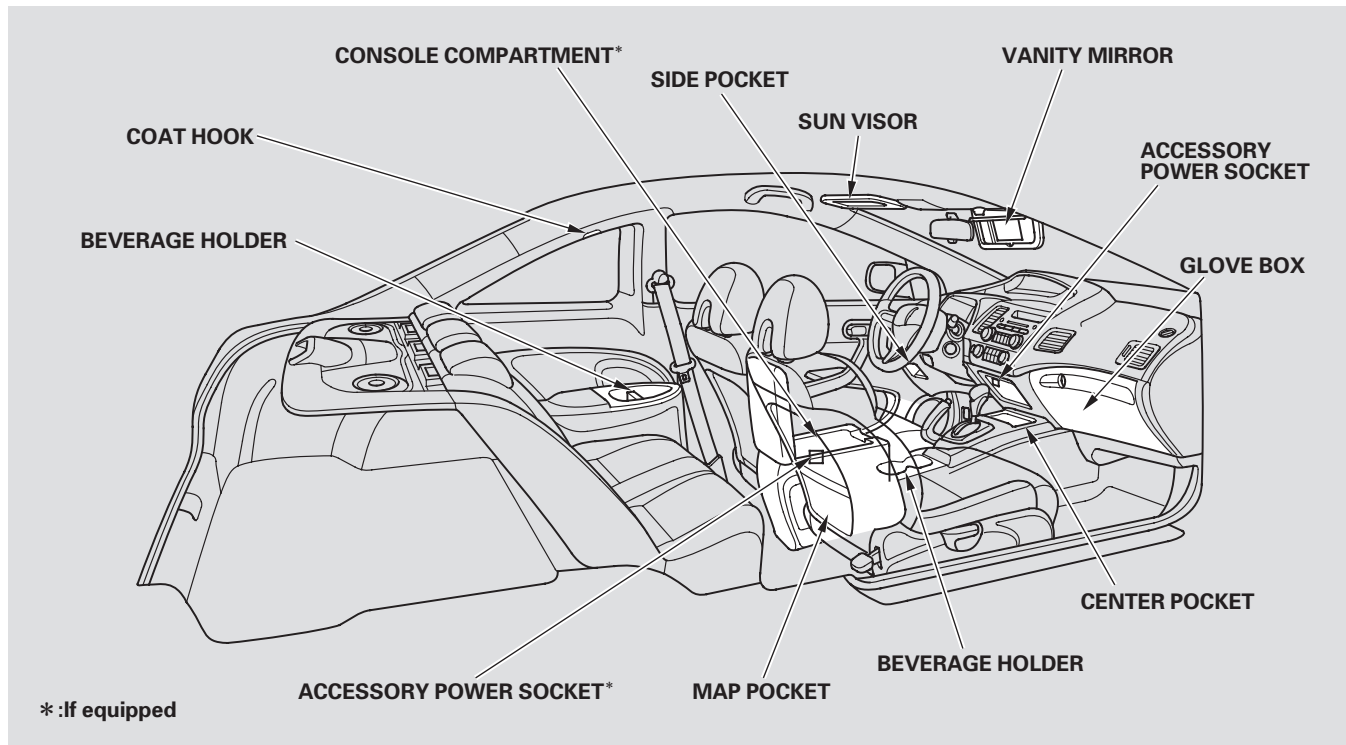

## Beverage Holders

Be careful when you are using the beverage holders. A spilled liquid that is very hot can scald you or your passengers. Spilled liquids can damage the upholstery, carpeting, and electrical components in the interior.

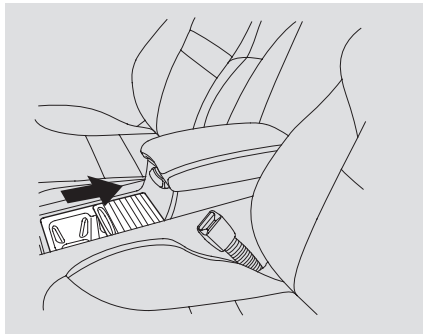

Open the front beverage holder by sliding the lid.

## Console Compartment

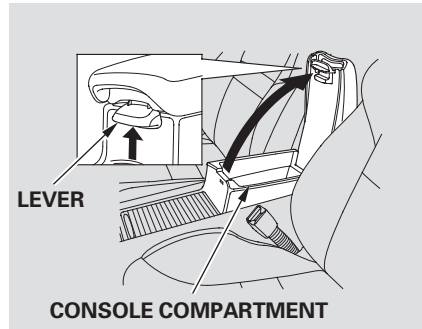

*If equipped*  
To open the console compartment, pull up on the lever, and lift the lid.

To close, lower the lid, and push it down until it latches.

## Glove Box

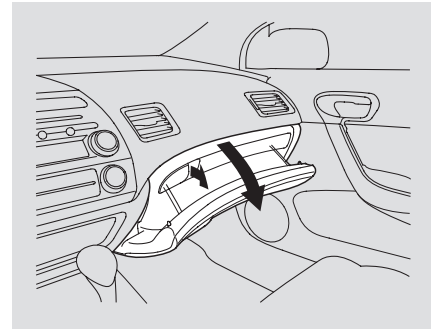

Open the glove box by pulling the handle to the left. Close it with a firm push.

CONTINUED



# Interior Convenience Items

## **⚠ WARNING**

An open glove box can cause serious injury to your passenger in a crash, even if the passenger is wearing the seat belt.

Always keep the glove box closed while driving.

## Coat Hook

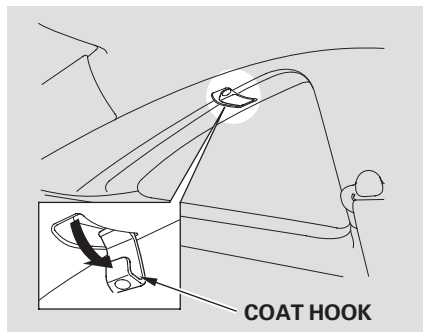

To use a coat hook, pull it down. Close it with a firm push.

Make sure the coat hook is closed when you are not using it. This hook is not designed for large or heavy items.

## Accessory Power Sockets

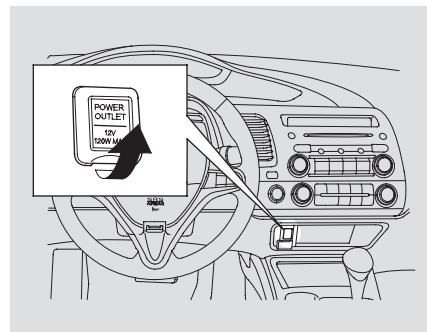

To use an accessory power socket, pull up the cover.

This socket is intended to supply power for 12 volt DC accessories that are rated 120 watts or less (10 amps).

To use an accessory power socket, the ignition switch must be in the ACCESSORY (I) or ON (II) position.

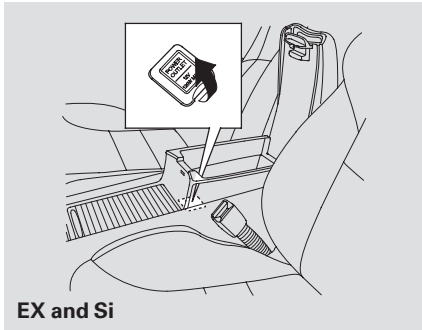

*On EX and Si models*  
Another accessory power socket is in the center console compartment.

None of the sockets will power an automotive type cigarette lighter element. When more than one socket is being used, the combined power rating of the accessories should be 120 watts or less (10 amps).

## Vanity Mirror

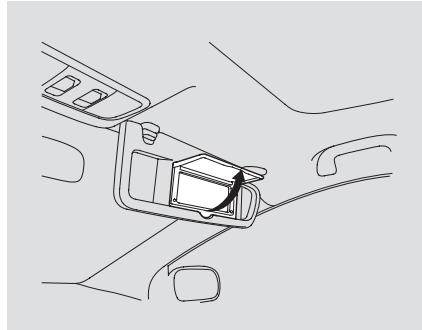

To use a vanity mirror on the back of the sun visor, pull up the cover.

## Sun Visor

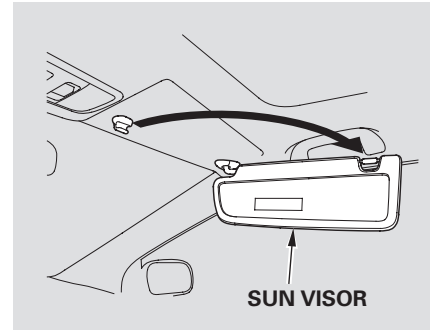

To use the sun visor, pull it down. When using the sun visor for the side window, remove the support rod from the clip, and swing it out.

Make sure you put the sun visor back in place when you are getting into or out of the vehicle.

# Interior Lights

## Ceiling Light

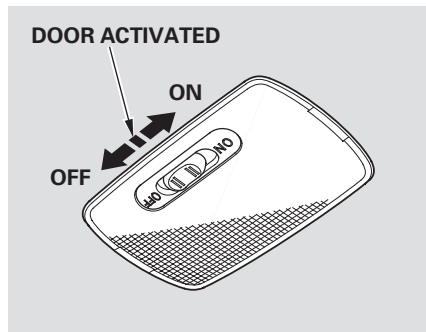

The ceiling light has a three-position switch; ON, Door Activated, and OFF. In the Door Activated (center) position, the light comes on when you:

- Open either door.
- Unlock the doors with the key or the remote transmitter.

After both doors are closed tightly, the light dims slightly, then fades out in about 30 seconds.

The ceiling light (with the switch in the center position) comes on when you remove the key from the ignition switch. If you do not open a door, the light stays on, then fades out in about 30 seconds.

If you leave either door open without the key in the ignition switch, the ceiling light goes off after 3 minutes.

## Spotlights

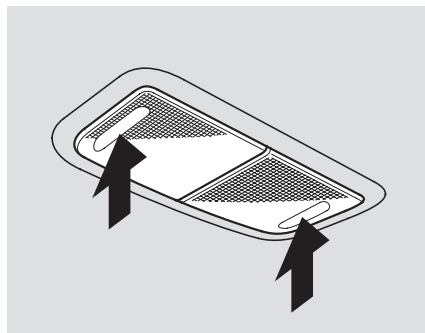

*On LX model*

Turn on a spotlight by pushing the lens. Push the lens again to turn it off. You can use the spotlights at all times.

*On EX and Si models*

The spotlights have a two-position switch. In the DOOR position, the lights come on when you open either door. In the OFF position, the lights do not come on.

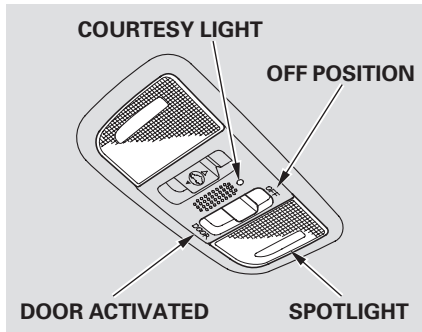

The spotlights (with the switch in the DOOR position) also come on when you unlock the door with the key or the remote transmitter, and when you remove the key from the ignition switch.

### **Courtesy Light**

*On EX and Si models*

The courtesy light between the spotlights comes on when you turn the parking lights on. To adjust its brightness, push the instrument panel brightness control buttons under the driver's side vent.

The heating and air conditioning\* systems in your vehicle provide a comfortable driving environment in all weather conditions.

\*Air conditioning is optional on DX model.

The standard audio system has many features. This section describes those features and how to use them. (If you have an optional audio system, refer to the operating instructions that came with it.)

### *All models except U.S. DX*

Your vehicle has an anti-theft audio system that requires a code number to enable it.

### *U.S. LX, EX, and Si models*

The security system helps to discourage vandalism and theft of your vehicle.

Navigation systems are available on U.S. EX and Si models only.

Vents, Heating, and A/C .....	110
Audio System .....	115
Audio System (Models without navigation system) .....	116
Playing the AM/FM Radio.....	117
Playing the XM® Satellite Radio (Optional) .....	121
Playing a Disc.....	126
Disc Player Error Messages ....	132
Optional Disc Changer Error Messages.....	133
Audio System (Models with navigation system) .....	134
Voice Control System.....	134
Playing the AM/FM Radio.....	134
Playing the XM® Satellite Radio .....	138
Playing a Disc.....	146
Disc Player Error Messages ....	154
Playing a PC Card.....	155
AM/FM Radio Reception.....	167
Protecting Your Discs.....	169
Remote Audio Controls.....	170
Playing an Optional Audio Unit....	171
Radio Theft Protection.....	172
Setting the Clock .....	173

Security System .....	174
Cruise Control.....	175

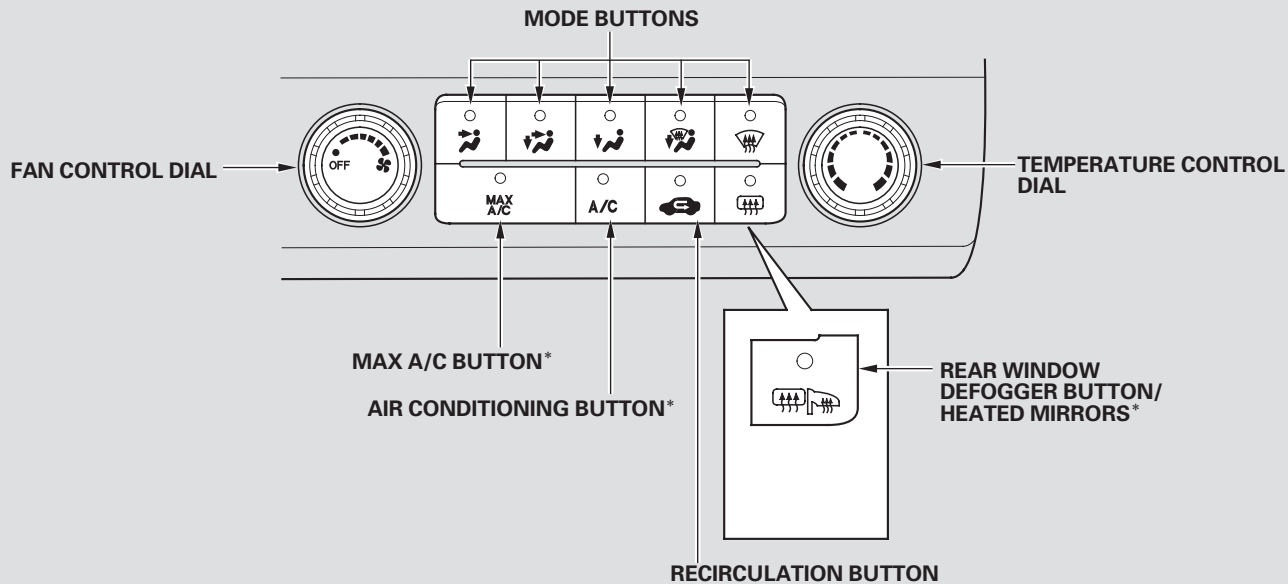

\* If equipped

## Fan Control Dial

Turn this dial to increase or decrease the fan speed and airflow.

## Temperature Control Dial

Turning this dial clockwise increases the temperature of the airflow.



## Air Conditioning (A/C) Button

*If equipped*

This button turns the air conditioning on and off. The indicator in the button is on when the A/C is on.

## MAX A/C Button

*If equipped*

 The system automatically turns on the A/C and switches to recirculation mode. Air flows from the center and side vents in the dashboard. Pressing the  or A/C button cancels MAX A/C.

## Recirculation Button

When the recirculation indicator is on, air from the vehicle's interior is sent throughout the system again. When the indicator is off, air is brought in from the outside of the vehicle (fresh air mode).

The outside air intakes for the heating and cooling system are at the base of the windshield. Keep this area clear of leaves and other debris.

The system should be left in fresh air mode under almost all conditions. Keeping the system in recirculation mode, particularly with the A/C off, can cause the windows to fog up.

Switch to recirculation mode when driving through dusty or smoky conditions, then return to fresh air mode.

## Rear Window Defogger Button

This button turns the rear window defogger off and on (see page 72).

On some models, this button also operates the heated outside mirrors (see page 101).

## Mode Control

Use the mode control buttons to select the vents air flows from. Some air will flow from the dashboard corner vents in all modes.





 Air flows from the center and corner vents in the dashboard.

 Airflow is divided between the vents in the dashboard and the floor vents.

CONTINUED

# Vents, Heating, and A/C

 Air flows from the floor vents.



When you select , the system automatically switches to fresh air mode. If you switch the mode from  or  to , the system keeps the A/C on. The A/C indicator will not come on if it was off to start with.

To turn off the A/C, press the A/C button to illuminate the indicator, then press it again to turn off the A/C.

When you switch to another mode from , the A/C turns off. But if it was on to start with, the A/C stays on.

 Airflow is divided between the floor vents and the defroster vents at the base of the windshield.

 Air flows from the defroster vents at the base of the windshield.

When you select  or , the system automatically switches to fresh air mode and turns on the A/C. You cannot turn the A/C off in this mode.





## Ventilation

The flow-through ventilation system draws in outside air, circulates it through the interior, then exhausts it through vents near the rear window.

1. Set the temperature to the lower limit.
2. Make sure the A/C is off.
3. Select  and fresh air mode.
4. Set the fan to the desired speed.

## Using the Heater

The heater uses engine coolant to warm the air. If the engine is cold, it will be several minutes before you feel warm air coming from the system.

1. Select  .  
When you select , the system automatically switches to fresh air mode. If you switch the mode from  or , the system also automatically turns on the A/C. This helps prevent the windows from fogging up unintentionally. The A/C indicator will not come on if it was off to start with (see the first column on this page).
2. Set the fan to the desired speed.
3. Adjust the warmth of the air with the temperature control dial.



## Using the A/C

Air conditioning places an extra load on the engine. Watch the engine coolant temperature gauge (see page 66). If it moves near the red zone, turn off the A/C until the gauge reading returns to normal.

1. Turn on the A/C by pressing the button. The indicator in the button comes on when a fan speed is selected.
2. Make sure the temperature is set to maximum cool.
3. Select .
4. If the outside air is humid, select recirculation mode. If the outside air is dry, select fresh air mode.
5. Set the fan to the desired speed.

*If the interior is very warm, you can cool it down more rapidly by partially opening the windows, turning on the A/C, and setting the fan to maximum speed in fresh air mode.*

To cool the interior with MAX A/C:

1. Set the fan to the desired speed.
2. Select MAX A/C mode.  
The system automatically turns on the A/C, selects , and switches to recirculation mode.
3. Make sure the temperature is set to maximum cool.

## Dehumidify the Interior



Air conditioning, as it cools, removes moisture from the air. When used in combination with the heater, it makes the interior warm and dry and can prevent the windows from fogging up.



1. Turn the fan on.
2. Turn on the air conditioning.
3. Select  and fresh air mode.
4. Adjust the temperature to your preference.

This setting is suitable for all driving conditions whenever the outside temperature is above 32°F (0°C).



## To Defog and Defrost

To remove fog from the inside of the windows:

1. Set the fan to the desired speed, or high for faster defrosting.
2. Select . The system automatically switches to fresh air mode and turns on the A/C. The A/C indicator will not come on if it was off to start with.
3. Adjust the temperature so the airflow feels warm.
4. Select  to help clear the rear window.
5. To increase airflow to the windshield, close the corner vents.

When you switch to , from  or , the A/C stays on. This helps prevent the windows from rapidly fogging up when the air is suddenly routed away from the windshield. If you want to turn the A/C off, press and release the A/C button twice. The indicator in the button comes on and then goes off.

## To Remove Exterior Frost or Ice From the Windows

1. Select . The system automatically switches to fresh air mode and turns on the A/C. The A/C indicator does not come on if it was off to start with.
2. Select .
3. Set the fan and temperature controls to maximum level.

To clear the windows faster, you can close the dashboard corner vents by rotating the wheel next to each vent. This sends more warm air to the windshield defroster vents. Once the windshield is clear, select fresh air mode to avoid fogging the windows.

For your safety, make sure you have a clear view through all the windows before driving.

## To Turn Everything Off

Turning the fan speed control dial all the way to the left shuts the system off.

- Keep the system off for short periods only.
- To keep stale air and mustiness from collecting, you should have the fan running at all times.

An audio system is standard on all models except the U.S. DX. Read the appropriate pages (as shown below) to use your vehicle's audio system.

For U.S. LX, non-navi EX and Si, and all Canadian models, see pages [116](#) through [136](#).

For U.S. EX and Si models with navigation system, see pages [137](#) through [168](#).

**U.S. LX model  
All Canadian models**

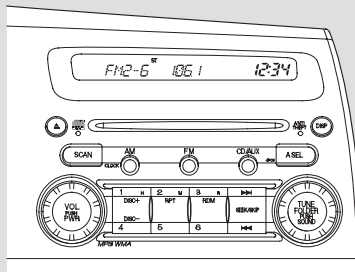

**U.S. EX and Si models  
without navigation system**

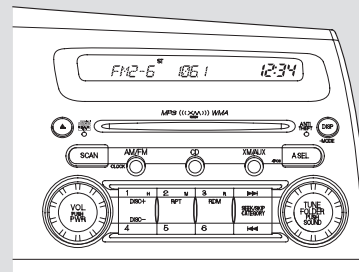

**U.S. EX and Si models  
with navigation system**

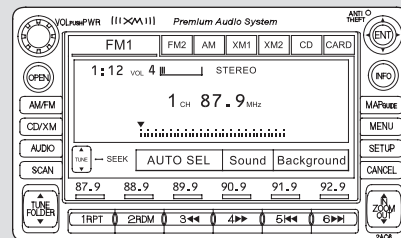

# Audio System (Models without navigation system)

Your audio system shows a welcome message on the display when you turn the ignition switch to the ACCESSORY (I) or the ON (II) position. You can see a message "WELCOME" on the display when your vehicle was new.

You can also customize this welcome message to your liking with the audio controls.

## To Customize a Message

You can set up to about 16 characters on the display.

To select a character:

1. Make sure the audio system is off.
2. Push and hold the TUNE knob, then push the power/volume knob on the audio control panel. You will see the first letter blinking.

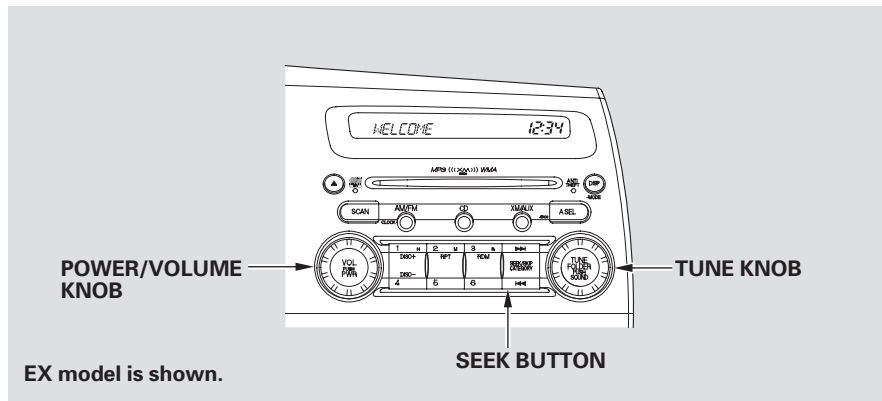

3. Turn the TUNE knob to change a letter.
4. Push the top of the SEEK button to select the next segment, then turn the TUNE knob to select a letter. Repeat this procedure to set your message.

To change the letter, select the previous segment by pushing the bottom of the SEEK button.

The system will return to the audio display about 5 seconds after you stop selecting a letter.

## Playing the AM/FM Radio

U.S. LX and all Canadian models

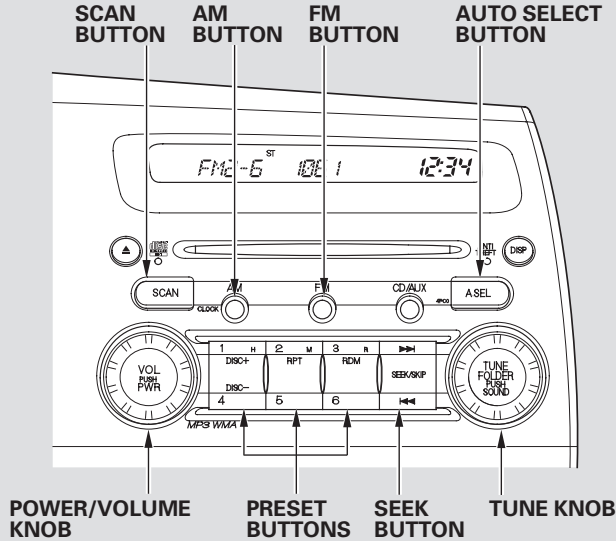

U.S. EX and Si models

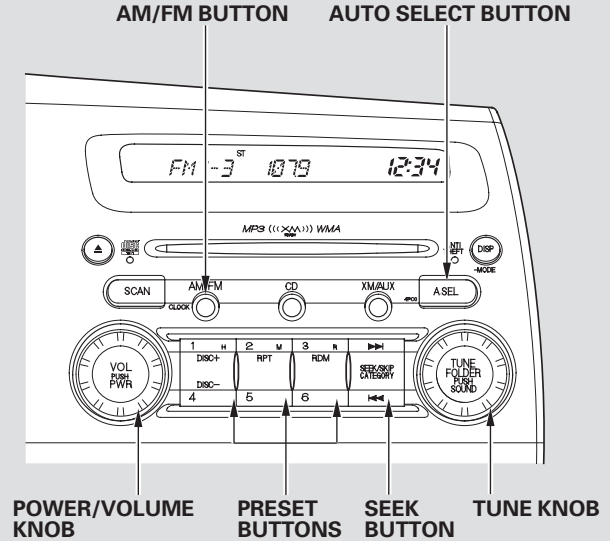

## Audio System (Models without navigation system)

---

### To Play the AM/FM Radio

The ignition switch must be in the ACCESSORY (I) or ON (II) position. Turn the system on by pushing the power/volume knob or the AM or FM button (the AM/FM button on models with XM radio available). Adjust the volume by turning the power/volume knob.

The band and frequency that the radio was last turned to are displayed. To change bands, press the AM or FM button (AM/FM button on models that are XM radio capable). On the FM band, ST will be displayed if the station is broadcasting in stereo. Stereo reproduction in AM is not available.

### To Select a Station

You can use any of five methods to find radio stations on the selected band: **TUNE**, **SEEK**, **SCAN**, the preset buttons, and **AUTO SELECT**.

**TUNE** — Use the TUNE knob to tune the radio to a desired frequency. Turn the knob to the right to tune a higher frequency, and turn it to the left to tune a lower frequency.

**SEEK** — The SEEK function searches up and down from the current frequency to find a station with a strong signal. To activate it, press the ◀◀ or ▶▶ side of the SEEK button, then release it.

**SCAN** — The scan function samples all stations with strong signals on the selected band. To activate it, press the SCAN button, then release it. You will see SCAN in the display. The system will scan for a station with a strong signal. When it finds one, it will stop and play that station for about 10 seconds.

If you do nothing, the system will then scan for the next strong station and play it for 10 seconds. When it plays a station you want to listen to, press the SCAN button again.

**Preset** — Each side of the buttons (1 through 6) can store one frequency on AM, and two frequencies on FM.

1. Select the desired band, AM or FM. FM1 and FM2 let you store two frequencies with each side of the preset button.
2. Use the tune, seek, or scan function to tune the radio to a desired station.
3. Pick a preset number (1–6), and hold it until you hear a beep.
4. Repeat steps 1 through 3 to store a total of six stations on AM and twelve stations on FM.

**AUTO SELECT** — If you are traveling far from home and can no longer receive your preset stations, you can use the auto select feature to find stations in the local area.

Press the A. SEL button. You will see A. SEL flashing in the display, and the system goes into scan mode for several seconds. It stores the frequencies of six AM, and twelve FM stations in the preset buttons.

You will see a “0” displayed after pressing a preset button if auto select cannot find a strong station for every preset button.

If you do not like the stations auto select has stored, you can store other frequencies on the preset buttons as previously described.

*To turn off auto select*, press the A. SEL button. This restores the presets you originally set.

For information on AM/FM radio frequencies and reception, see page [167](#).

## Audio System (Models without navigation system)

---

### Adjusting the Sound

Press the TUNE (SOUND) knob repeatedly to display the BASS, TREBLE, FADER, BALANCE, SUBWOOFER (if equipped), and SVC (speed-sensitive volume compensation) settings.

**BASS** — Adjusts the bass.

**TREBLE** — Adjusts the treble.

**FADER** — Adjusts the front-to-back strength of the sound.

**BALANCE** — Adjusts the side-to-side strength of the sound.

*If equipped*

**SUBWOOFER** — Adjusts the strength of sound from the subwoofer speaker.

**SVC** — Adjusts the volume level based on the vehicle speed.

Each mode is shown in the display as it changes. Turn the TUNE knob to adjust the setting to your liking. When the level reaches the center, you will see “C” in the display.

The system will return to the audio display about 5 seconds after you stop adjusting a mode.

### *Speed-sensitive Volume Compensation (SVC)*

The SVC mode controls the volume based on vehicle speed. The faster you go, the louder the audio volume becomes. As you slow down, the audio volume decreases.

The SVC has four modes; SVC OFF, SVC LOW, SVC MID, and SVC HIGH. Turn the TUNE knob to adjust the setting to your liking. If you feel the sound is too loud,

choose low. If you feel the sound is too quiet, choose high.

This function is set to MID as the default setting when the vehicle leaves the factory.

### Audio System Lighting

You can use the instrument panel brightness control buttons to adjust the illumination of the audio system (see page 71). The audio system illuminates when the parking lights are on, even if the radio is off.



## Playing the XM® Satellite Radio *Optional on U.S. EX and Si models*

Your audio system is capable of receiving XM® Satellite Radio anywhere in the United States, except Hawaii and Alaska.

XM® is a registered trademark of XM Satellite Radio, Inc.

XM radio receives signals from two satellites to produce clear, high-quality digital reception. It offers many channels in several categories. Along with a large selection of different types of music, XM radio allows you to view channel and category selections in the display.

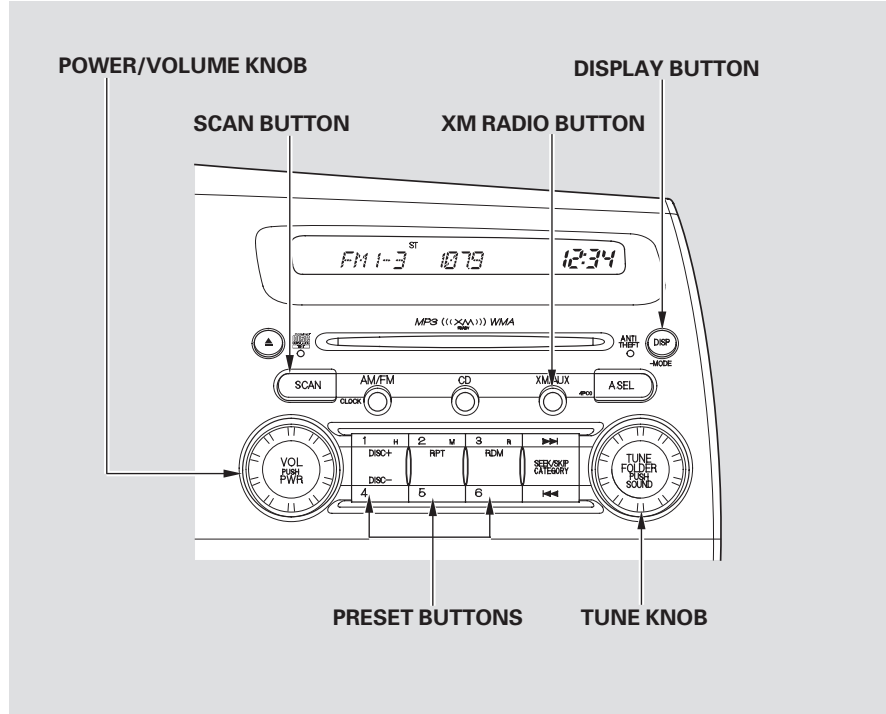

## Audio System (Models without navigation system)

---

### Operating the XM Radio

To listen to XM radio, turn the ignition switch to the ACCESSORY (I) or the ON (II) position. Push the power/volume knob to turn on the audio system, and press the “XM” button. Adjust the volume by turning the knob. The last channel you listened to will show in the display.

**MODE** — To switch between channel mode and category mode, press and hold the DISP/MODE button until the mode changes. In channel mode, you can select all of the available channels. In category mode, such as Jazz, Rock, Classical, etc., you can select all of the channels within that category. Each time you press and release the DISP/MODE button, the display changes in the following sequence: Channel name, channel number, category, artist name, and music title.

You may experience periods when XM Radio does not transmit the artist’s name and song title information. If this happens, there is nothing wrong with your system.

**TUNE** — Turn the TUNE knob to change channel selections. Turn the knob right for higher numbered channels and left for lower numbered channels. In the category mode, you can only select channels within that category.

**SEEK/SKIP (CATEGORY)** — Press either side of the CATEGORY button ( ◀◀ or ▶▶ ) to select another category.

**SCAN** — The scan function gives you a sampling of all channels while in the channel mode. In the category mode, only the channels within that category are scanned. To activate scan, press the SCAN button. The system plays each channel in numerical order for a few seconds, then selects the next channel. When you hear a channel you want to continue listening to, press the button again.

**Preset** — You can store up to 12 preset channels using each side of the preset button. Each side of the button stores one channel from the XM1 band and one channel from the XM2 band.

To store a channel:

1. Press the XM button. Either XM1 or XM2 will show in the display.

2. Use the tune, seek, or scan function to tune to a desired channel.

In category mode, only channels within that category can be selected. In channel mode, all channels can be selected.

3. Pick a preset number you want for that channel. Press and hold the button until you hear a beep.
4. Repeat steps 2 and 3 to store the first six channels.
5. Press the XM button again. Store the next six channels using steps 2 and 3.

Once a channel is stored, press and release the proper side of the preset button to tune to it.

## XM Radio Display Messages

**“LOADING”** — XM is loading the audio or program information.

**“OFF AIR”** — The channel currently selected is no longer broadcasting.

**“UPDATING”** — The encryption code is being updated. Wait until the encryption code is fully updated. Channels 0 and 1 should still work normally.

**“NO SIGNAL”** — The signal is currently too weak. Move the vehicle to an area away from tall buildings, and with an unobstructed view of the southern horizon.

*CONTINUED*

## Audio System (Models without navigation system)

“----” — The selected channel number does not exist or is not part of your subscription, or this channel has no artist or title information at this time.

“ANTENNA” — There is a problem with the XM antenna. Please consult your dealer.

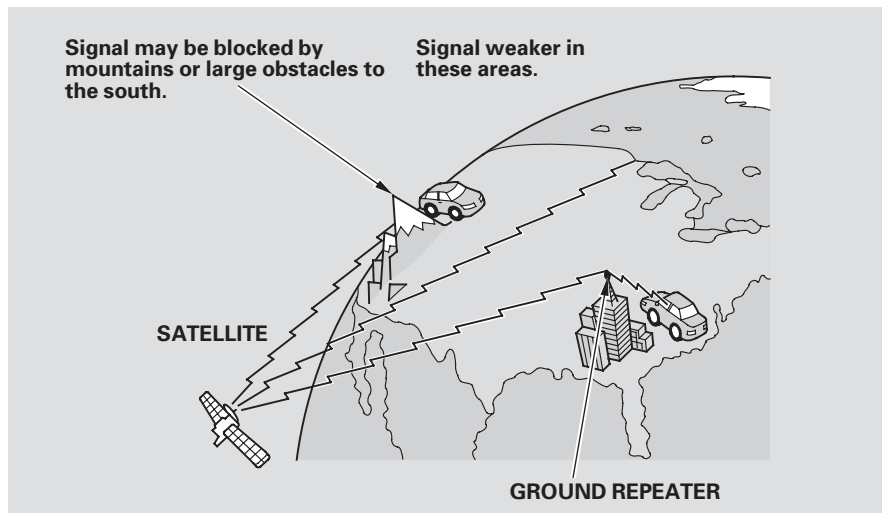

The XM satellites are in orbit over the equator; therefore, objects south of the vehicle may cause satellite reception interruptions. To help compensate for this, ground-based repeaters are placed in major metropolitan areas.

Satellite signals are more likely to be blocked by tall buildings and mountains the farther north you travel from the equator. Carrying large items on a roof rack can also block the signal.

Depending on where you drive, you may experience reception problems. Interference can be caused by any of these conditions:

- Driving on the north side of an east/west mountain road.
- Driving on the north side of a large commercial truck on an east/west road.
- Driving in tunnels.
- Driving on a road beside a vertical wall, steep cliff, or hill to the south of you.
- Driving on the lower level of a multi-tiered road.
- Driving on a single lane road alongside dense trees taller than 50 ft. (15 m) to the south of you.
- Large items carried on a roof rack.

There may be other geographic situations that could affect XM radio reception.

*As required by the FCC:  
Changes or modifications not expressly approved by the party responsible for compliance could void the user's authority to operate the equipment.*

### **Receiving Satellite Radio Service**

If your XM Radio service has expired or you purchased your vehicle from a previous owner, you can listen to a sampling of the broadcasts available on XM Satellite Radio. With the ignition switch in the ACCESSORY (I) or ON (II) position, push the power/volume knob to turn on the audio system and press the XM RADIO button. A variety of music types and styles will play.

If you decide to purchase XM satellite radio service, contact XM Radio at [www.xmradio.com](http://www.xmradio.com), or at 1-800-852-9696. You will need to give them your radio I.D. number and your credit card number. To get your radio I.D. number, turn the TUNE

knob until "0" appears in the display. Your I.D. will appear in the display.

After you've registered with XM Radio, keep your audio system in the satellite radio mode while you wait for activation. This should take about 30 minutes.

While waiting for activation, make sure your vehicle remains in an open area with good reception. Once your audio system is activated, you'll be able to listen to XM radio broadcasts. XM Radio will continue to send an activation signal to your vehicle for at least 12 hours from the activation request. If the service has not been activated after 36 hours, contact XM Radio.

# Audio System (Models without navigation system)

## Playing a Disc

U.S. LX model  
All Canadian models

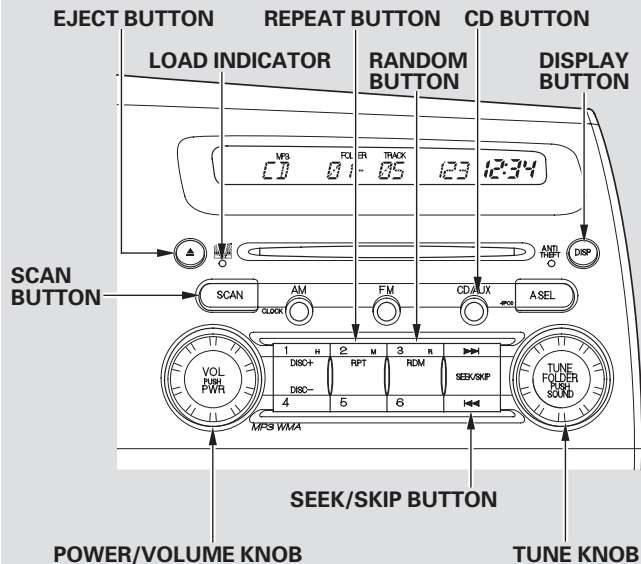

U.S. EX and Si models

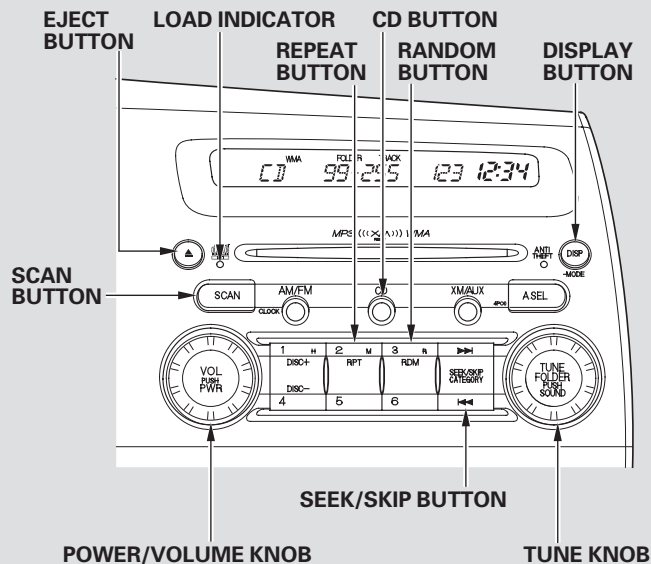

## To Play a Disc

To load or play discs, the ignition switch must be in the ACCESSORY (I) or ON (II) position.

You operate the disc player with the same controls used for the radio. To select the disc player, press the CD/AUX button (the CD button on models with XM radio available). You will see "CD" in the display.

### NOTICE

*Do not use discs with adhesive labels. The label can curl up and cause the disc to jam in the unit.*

This audio system can also play CD-Rs and CD-RWs compressed in MP3 or WMA formats. When playing a disc in MP3, you will see "MP3" in the display. In WMA format, "WMA" will appear in the display. You can select up to 255 folders or tracks.

## NOTE:

If a file on an MP3 or WMA disc is protected by digital rights management (DRM), the audio unit displays FORMAT, and then skips to the next file.

Video CDs and DVD discs do not work in this unit.

The specifications of the compatible MP3 file are:

- Sampling frequency:  
32/44.1/48 kHz (MPEG1)  
24/22.05/16 kHz (MPEG2)
- Bit rate:  
32/40/48/56/64/80/96/112/128/  
160/192/224/256/320 kbps  
(MPEG1)  
8/16/24/32/40/48/56/64/80/96/  
112/128/160 kbps (MPEG2)
- Compatible with variable bit rate and multi-session
- Maximum layers  
(including ROOT): 8 layers

The specifications of the compatible WMA file are:

- Bit rate:  
48/64/80/96/128/160/192 kbps
- Sampling frequency: 32/44.1/48 kHz
- Compatible with variable bit rate and multi-session
- Maximum layers  
(including ROOT): 8 layers

## To Load a Disc

Insert a disc about halfway into the disc slot. The drive will pull the disc in the rest of the way to play it. You operate the disc player with the same controls used for the radio. The number of the current track and the elapsed time are shown in the display. When playing a disc in MP3 or WMA, the numbers of the current folder and file, and the elapsed time are shown. The system will continuously play a disc until you change modes.

CONTINUED

*In MP3 or WMA mode*

**FOLDER SELECTION** — To select a different folder, turn the TUNE knob to move the beginning of the next folder. Turn the knob to the right to skip to the next folder, and to the left to move to the beginning of the current folder. Turn it again to skip to the beginning of the previous folder. Turning the TUNE knob more than one click skips several folders at a time.

**REPEAT (TRACK/FILE REPEAT)** — To continuously replay a track (files in MP3 or WMA mode), press and release the RPT button. You will see RPT in the display. Press and hold the RPT button for 2 seconds to turn it off.

*In MP3 or WMA mode*

**FOLDER-REPEAT** — This feature, when activated, replays all files on the selected folder in the order they are compressed. To activate folder

repeat, press the RPT button twice. You will hear a beep and see F-RPT in the display. The system continuously replays the current folder. Press the RPT button again to turn it off. Pressing the RDM button, or selecting a different folder with the TUNE knob also turns off the repeat feature.

Each time you press and release the RPT button, the mode changes from file repeat to folder repeat, then to normal playing.

**RANDOM (Random within a disc/folder)** — This feature plays the tracks within a disc (the files within a folder in MP3 or WMA mode) in random order. To activate random play, press and release the RDM button. In MP3 or WMA mode, press the RDM button repeatedly to select RDM (within a folder random play). You will see RDM in the display. Press the RDM button for 2

seconds to return to normal play.

*In MP3 or WMA mode*

**FOLDER-RANDOM** — This feature, when activated, plays all files in each folder in random order. To activate folder random, press the RDM button 2 times. You will hear a beep and see F-RDM in the display. The system will then select and play files randomly. This continues until you deactivate folder random by pressing the RDM button again, or by selecting a different folder with the TUNE knob.

Each time you press and release the RDM button, the mode changes from folder random play to random play (within a folder random play), then to normal playing.

CONTINUED



## Audio System (Models without navigation system)

---

### **SCAN (TRACK/FILE SCAN) —**

The scan function samples all tracks (files in MP3 or WMA) on the disc in the order they are recorded on the disc. To activate scan, press the SCAN button. In MP3 or WMA mode, press the SCAN button repeatedly to select SCAN. You will see SCAN in the display. You will get a 10 second sampling of each track/file on the disc. Press the SCAN button again to get out of scan mode and play the last track/file sampled.

Pressing either side of the SEEK/SKIP button also turns off the scan feature.

*In MP3 or WMA mode*

### **F-SCAN (FOLDER SCAN) —**

This feature, when activated, samples the first file of each folder on the disc. To activate folder scan, press the SCAN button twice. You will see F-SCAN in the display.

The system plays the first file in the first folder for about 10 seconds. If you do nothing, the system will then play the first files in the remaining folders for 10 seconds each. After playing the first file of the last folder, the system plays normally.

Pressing either side of the SEEK/SKIP button, selecting a different folder with the TUNE knob, or pressing the SCAN button, also turns off the folder scan.

Each time you press and release the SCAN button, the mode changes from folder scan to scan, then to normal playing.

### **To Stop Playing a Disc**

Press the eject button (  ) to remove the disc. If you eject the disc, but do not remove it from the slot, the system will automatically reload it after 10 seconds and put it in pause mode. To begin playing, press the CD button.

You can also eject the disc when the ignition switch is off.

To play the radio when a disc is playing, press the AM or FM button (the AM/FM button or XM button on models that are XM radio capable). Press the CD button again to switch back to the disc player.

If you turn the system off while a disc is playing, either with the power/volume knob or by turning off the ignition switch, the disc will stay in the drive. When you turn the system back on, the disc will begin playing where it left off.

### Operating the Optional Disc Changer

An optional six or eight disc changer is available for your vehicle. This disc changer uses the same controls used for the in-dash disc player or the radio.

Load the desired discs in the magazine, and load the magazine in the changer according to the instructions that came with the unit.

To select the disc changer, press the CD button. The disc and track numbers will be displayed. To select a different disc, use the preset 4 (DISC -) or the preset 1 (DISC +) on the preset button. To select the previous disc, press the preset 4 (DISC -), or the preset 1 (DISC +) to select the next disc in sequence.

If you select an empty slot in the magazine, the changer will search for the next available disc to load and play.

### Protecting Discs

For information on how to handle and protect compact discs, see page [169](#).

## Audio System (Models without navigation system)

---

### Disc Player Error Messages

If you see an error message in the display while playing a disc, find the cause in the chart to the right. If you cannot clear the error message, take your vehicle to your dealer.

Error Message	Cause	Solution
<i>CD</i> DISC ERROR	FOCUS Error	Press the eject button, and pull out the disc. Check if it is inserted correctly in the disc player. Make sure the disc is not scratched or damaged.
<i>CD</i> MECH ERROR	Mechanical Error	Press the eject button, and pull out the disc. Check the disc for damage or deformation. If the disc cannot be pulled out, or the error message does not disappear after the disc is ejected, see your dealer.
<i>CD</i> HEAT ERROR	High Temperature	Will disappear when the temperature returns to normal.

## Optional Disc Changer Error Messages

If you see an error message in the display while playing a disc, find the cause in the chart to the right. If you cannot clear the error message, take your vehicle to your dealer.

Error Message	Cause	Solution
<i>CDC DISC ERROR</i>	FOCUS Error	Press the magazine eject button, and pull the magazine out. If the message does not disappear or the magazine cannot be pulled out, see your dealer.
<i>CDC NO DISC</i>	No disc in the disc magazine	Insert disc.
<i>CDC MECH ERROR</i>	Mechanical Error	Press the magazine eject button, pull the magazine out, check for an error message, then insert the magazine again. If the message does not disappear, or the magazine cannot be pulled out, see your dealer.
<i>CDC EJECT</i>	No disc magazine in the disc changer	Insert disc magazine.
<i>CDC HEAT ERROR</i>	High Temperature	Will disappear when the temperature returns to normal.

# Audio System (Models with navigation system)

## Voice Control System

In addition to the standard audio controls, the audio system in your vehicle can be operated using the voice control system. See the navigation section in your quick start guide for an overview of this system, and the navigation system manual for complete details.

## Playing the AM/FM Radio

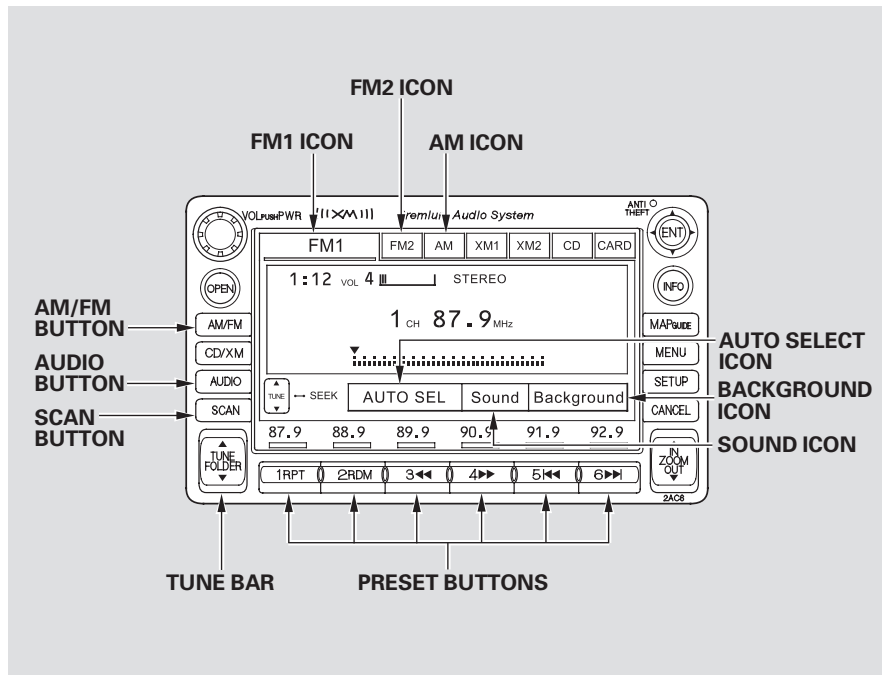

## To Play the AM/FM Radio

The ignition switch must be in the ACCESSORY (I) or ON (II) position. Turn the system on by pushing the power/volume knob or the AM/FM button. Adjust the volume by turning the power/volume knob.

Pushing the AUDIO button will also turn on the system.

You can also operate the audio system without using the control icons on the audio screen. Use the control buttons on the left side of the screen. The status bar appears on the bottom of the screen each time you operate any of the control buttons. On the navigation screen, you can also see audio information by touching the AUDIO INFO icon on the lower of the screen.

The band and frequency that the radio was last turned to are displayed. To change bands, press the AM/FM button, or touch the desired band icon (FM1, FM2, AM, XM1, or XM2). On the FM band, STEREO will be displayed if the station is broadcasting in stereo. Stereo reproduction on AM is not available.

For information on XM radio, see page [138](#).

## To Select a Station

You can use any of five methods to find radio stations on the selected band: TUNE, SEEK, SCAN, the preset buttons, and AUTO SELECT.

**TUNE** – Use the TUNE bar to tune the radio to a desired frequency. Press the ▲ side of the bar to tune to a higher frequency, and press the ▼ side to tune to a lower frequency.

Press and hold the ▲ or ▼ side of the TUNE bar until you hear two beeps to change the frequency rapidly. Release the bar when the display reaches the desired frequency.

CONTINUED

## Audio System (Models with navigation system)

---

**SEEK** — The seek function searches up and down from the current frequency to find a station with a strong signal. To activate it, press and hold the ▲ or ▼ side of the TUNE bar until you hear a beep, then release it.

**SCAN** — The scan function samples all stations with strong signals on the selected band. To activate it, press the SCAN button, then release it. You will see SCAN in the display. The system will scan for a station with a strong signal. When it finds one, it will stop and play that station for about 10 seconds.

If you do nothing, the system will then scan for the next strong station and play it for 10 seconds. When it plays a station you want to listen to, press the SCAN button again.

**Preset** — Each preset button can store one frequency on AM and two frequencies on FM.

1. Select the desired band, AM or FM. FM1 and FM2 let you store two frequencies with each preset button.
2. Use the tune, seek, or scan function to tune the radio to a desired station.
3. Pick a preset button, and hold it until you hear a beep.
4. Repeat steps 1 through 3 to store a total of six stations on AM and twelve stations on FM.

Each preset button's frequency is shown on the bottom of the audio display.

**AUTO SELECT** – If you are traveling far from home and can no longer receive your preset stations, you can use the auto select feature to find stations in the local area.

Press the AUDIO button to view the audio control icons, then press the AUTO SEL icon. You will see AUTO SEL flashing in the display, and the system goes into scan mode for several seconds. It stores the frequencies of six AM, and twelve FM stations in the preset buttons.

You will see a “0” displayed after pressing a preset button if auto select cannot find a strong station for every preset button.

If you do not like the stations auto select has stored, you can store other frequencies on the preset buttons as previously described.

*To turn off auto select*, press the AUTO SEL icon. This restores the presets you originally set.

For information on AM/FM radio frequencies and reception, see page [167](#).



# Audio System (Models with navigation system)

## Playing the XM® Satellite Radio \*

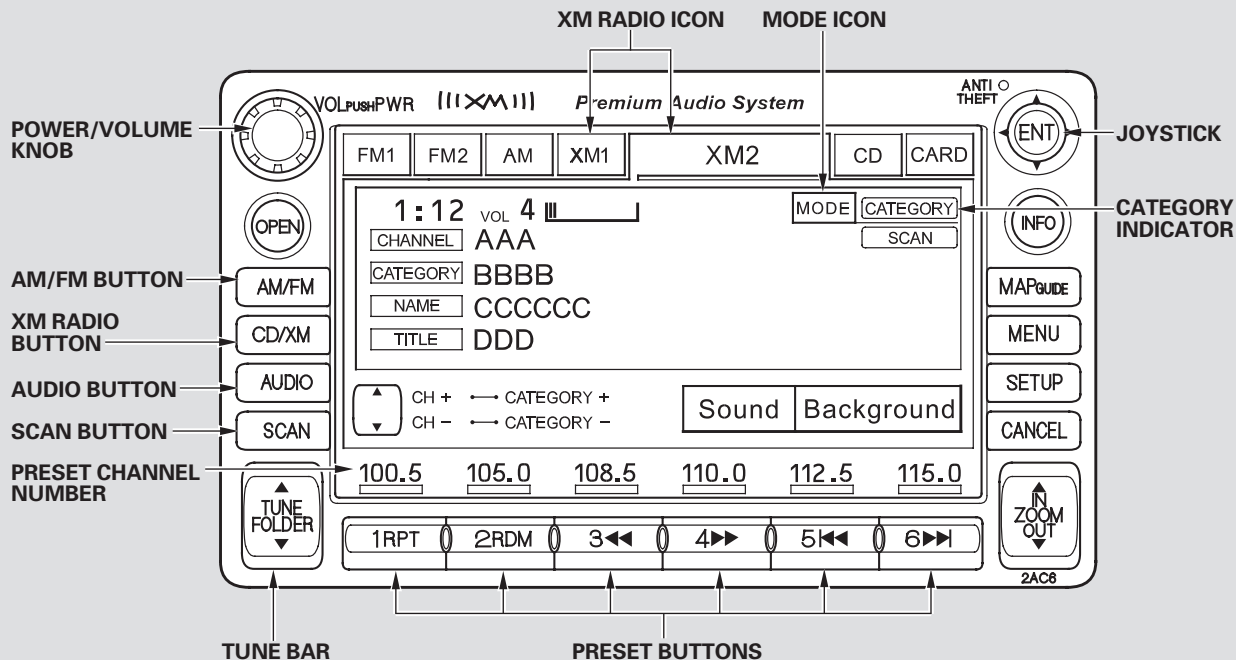

\* U.S. models only

Your audio system is capable of receiving XM<sup>®</sup> Satellite Radio anywhere in the United States, except Hawaii and Alaska.

XM<sup>®</sup> is a registered trademark of XM Satellite Radio, Inc.

XM radio receives signals from two satellites to produce clear, high-quality digital reception. It offers many channels in several categories. Along with a large selection of different types of music, XM radio allows you to view channel and category selections in the display. When you press and hold the AUDIO button, the display also shows all XM information.

### Operating the XM Radio

To listen to XM radio, turn the ignition switch to the ACCESSORY (I) or the ON (II) position. Push the power/volume knob to turn on the audio system, and press the CD/XM button. Adjust the volume by turning the knob. The last channel you listened to will show in the display.

You can also change to the XM radio while you are listening to an FM station, AM station, disc, pc card, etc., by touching the XM1 or XM2 icon on the audio display.

You can also operate the radio using the control buttons on the left side of the screen. The status bar appears on the bottom of the screen each time you press any of the control buttons. On the navigation screen, you can also see the audio information by touching the AUDIO INFO icon on the lower of the screen.

**MODE** — To switch between channel mode and category mode, touch the MODE icon. In channel mode, you can select all of the available channels. In category mode, such as Jazz, Rock, Classical, etc., you can select all of the channels within that category. Each time you touch and release the MODE icon, the display changes between the channel mode and the category mode.

*CONTINUED*

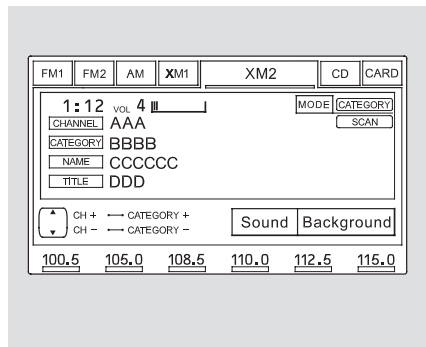

On the audio display, you will see the selected CHANNEL (number), CATEGORY, NAME (artist name), and TITLE (music title).

You may experience periods when XM Radio does not transmit the artist's name and song title information. If this happens, there is nothing wrong with your system.

**TUNE** — Press the TUNE bar to change channel selections. Press ▲ for higher numbered channels and ▼ for lower numbered channels. In the category mode, you can only select channels within that category.

**CATEGORY** — Press and hold either side of the TUNE bar ( |◀◀ or ▶▶| ) until you hear a beep to select another category.

**SCAN** — The scan function gives you a sampling of all channels while in the channel mode. In the category mode, only the channels within that category are scanned. To activate scan, press the SCAN button or touch the SCAN icon on the screen. The system plays each channel in numerical order for a few seconds, then selects the next channel. When you hear a channel you want to listen to, press the button or touch the icon again.

**Preset** — You can store up to 12 preset channels using each preset button or preset icons on the screen. Each preset button or icon stores one channel from the XM1 band and one channel from the XM2 band.

To store a channel:

1. Press the XM button. Either XM1 or XM2 will show in the display.
2. Use the tune, seek, or scan function to tune to a desired channel.

In category mode, only channels within that category can be selected. In channel mode, all channels can be selected.

3. Pick the preset button (icon) you want for that channel. Press and hold the button (icon) until you hear a beep.

4. Repeat steps 2 and 3 to store the first six channels.
5. Press the XM button again or touch the other XM icon (XM1 or XM2) on the audio display. Store the next six channels using steps 2 and 3.

Once a channel is stored, press and release the proper preset button (icon) to tune to it. Each preset button's channel is shown on the bottom of the audio display.

## XM Radio Display Messages

**“LOADING”** – XM is loading the audio or program information.

**“OFF AIR”** – The channel currently selected is no longer broadcasting.

**“UPDATING”** – The encryption code is being updated. Wait until the encryption code is fully updated. Channels 0 and 1 should still work normally.

**“NO SIGNAL”** – The signal is currently too weak. Move the vehicle to an area away from tall buildings, and with an unobstructed view of the southern horizon.

**“ - - - - ”** – The selected channel number does not exist or is not part of your subscription.

**“NO INFO”** – This channel has no artist or title information at this time.

**“ANTENNA”** – There is a problem with the XM antenna. Please consult your dealer.

*CONTINUED*

## Audio System (Models with navigation system)

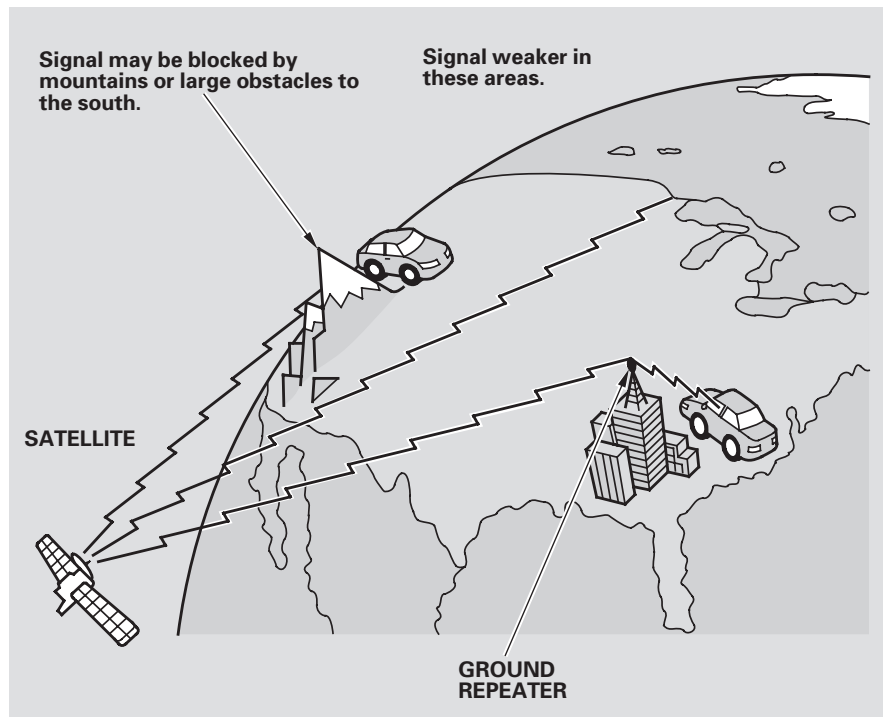

The XM satellites are in orbit over the equator; therefore, objects south of the vehicle may cause satellite reception interruptions. To help compensate for this, ground-based repeaters are placed in major metropolitan areas.

Satellite signals are more likely to be blocked by tall buildings and mountains the farther north you travel from the equator. Carrying large items on a roof rack can also block the signal.

Depending on where you drive, you may experience reception problems. Interference can be caused by any of these conditions:

- Driving on the north side of an east/west mountain road.
- Driving on the north side of a large commercial truck on an east/west road.
- Driving in tunnels.
- Driving on a road beside a vertical wall, steep cliff, or hill to the south of you.
- Driving on the lower level of a multi-tiered road.
- Driving on a single lane road alongside dense trees taller than 50 ft. (15 m) to the south of you.
- Large items carried on a roof rack.

There may be other geographic situations that could affect XM radio reception.

*As required by the FCC:  
Changes or modifications not expressly approved by the party responsible for compliance could void the user's authority to operate the equipment.*

### **Receiving Satellite Radio Service**

If your XM Radio service has expired or you purchased your vehicle from a previous owner, you can listen to a sampling of the broadcasts available on XM Satellite Radio. With the ignition switch in the ACCESSORY (I) or ON (II) position, push the power/volume knob to turn on the audio system and press the XM RADIO button. A variety of music types and styles will play.

If you decide to purchase XM Satellite Radio service, contact XM Radio at [www.xmradio.com](http://www.xmradio.com), or at 1-800-852-9696. You will need to give them your radio I.D. number and your credit card number. To get your radio I.D. number, press the TUNE

bar until "0" appears in the display. Your I.D. will appear in the display.

After you've registered with XM Radio, keep your audio system in the satellite radio mode while you wait for activation. This should take about 30 minutes.

While waiting for activation, make sure your vehicle remains in an open area with good reception. Once your audio system is activated, you'll be able to listen to XM radio broadcasts. XM Radio will continue to send an activation signal to your vehicle for at least 12 hours from the activation request. If the service has not been activated after 36 hours, contact XM Radio.

## Adjusting the Sound

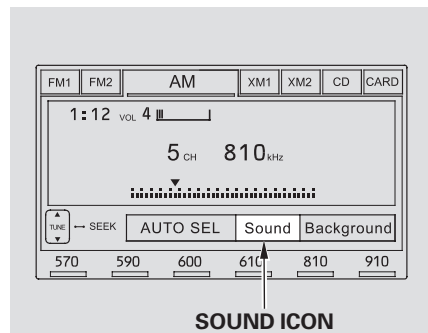

You can adjust the sound on the navigation screen. To adjust the sound, push the AUDIO button, then enter the sound grid by touching the SOUND icon on the display.

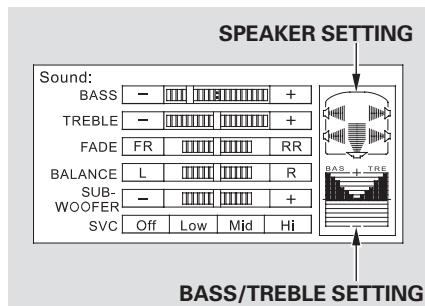

**BASS** — Adjusts the bass.

**TREBLE** — Adjusts the treble. To adjust the treble and bass, touch **+** or **-** on each side of the treble or bass adjustment bar. The adjustment bar on the right lower display shows you the current setting.

**FADER** — Adjusts the front-to-back strength of the sound. To adjust the front/rear fader, touch the FR or RR icon.

**BALANCE** — Adjusts the side-to-side strength of the sound. To adjust the left/right balance, touch the L or R icon.

**SUBWOOFER** — Adjusts the strength of sound from the subwoofer speaker. To adjust the sound strength, touch **+** or **-** on each side of the adjustment bar.

The right upper display shows you the current setting of the sound strength coming from each speaker.

**SVC (speed-sensitive volume compensation)** — The SVC mode controls the volume based on vehicle speed. The faster you go, the louder the audio volume becomes. As you slow down, the audio volume decreases. Touch the appropriate icon (Low, Mid, Hi, Off) to select the mode.

This function is set to MID as the default setting when the vehicle leaves the factory. If you feel the sound is too loud, choose low. If you feel the sound is too quiet, choose Hi.

You can also select the icon with the joystick. Move it up and down to move the highlighting and scroll through lists. Select the icon, then move the joystick to left or right to change the setting.

The system will return to the audio display about 5 seconds after you stop adjusting a mode.

### **Screen Mode**

You can select the background screen to display the sound level. There are three screen modes: level (the sound level is shown with the vertical bars), spectrum analysis (the sound level appears as ripples of water), and off. Each time you touch the background icon, the display changes.

### **Audio System Lighting**

You can use the instrument panel brightness control buttons to adjust the illumination of the audio system (see page 71 ). The audio system illuminates when the parking lights are on, even if the radio is off.



# Audio System (Models with navigation system)

## Playing a Disc

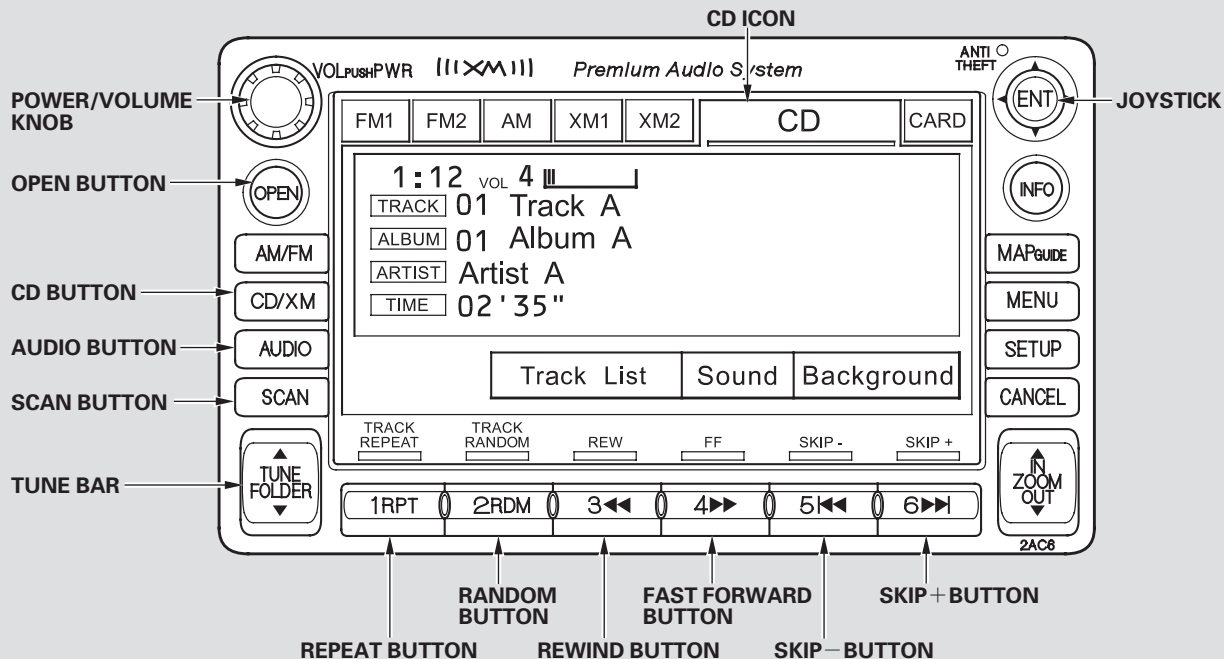

## To Play a Disc

You operate the disc player with the same controls used for the radio. To load or play discs, the ignition switch must be in the ACCESSORY (I) or ON (II) position.

### NOTICE

*Do not use discs with adhesive labels. The label can curl up and cause the disc to jam in the unit.*

This audio system can also play CD-Rs and CD-RWs compressed in MP3 or WMA formats. When playing a disc in MP3, you will see “MP3” on the screen. In WMA format, “WMA” will appear on the screen. You can select up to 99 folders and play up to 999 tracks. If the disc has a complex structure, it takes a while to read the disc before the system begins to play it.

Video CDs and DVD discs do not work in this unit.

The specifications for compatible MP3 files are:

- Sampling frequency:
  - 32/44.1/48 kHz (MPEG1)
  - 24/22.05/16 kHz (MPEG2)
- Bit rate: 32/40/48/56/64/80/96/112/128/160/192/224/256/320 kbps (MPEG1)
- 8/16/24/32/40/48/56/64/80/96/112/128/160 kbps (MPEG2)
- Compatible with variable bit rate and multi-session
- Maximum layers (including ROOT): 8 layers

The specifications for compatible WMA files are:

- Sampling frequency: 32/44.1/48 kHz
- Bit rate: 48/64/80/96/128/160/192 kbps
- Compatible with variable bit rate and multi-session
- Maximum layers (including ROOT): 8 layers

### NOTE:

If a file on an MP3 or WMA disc is protected by digital rights management (DRM), the audio unit displays CD FORMAT, and then skips to the next file.

CONTINUED

## Audio System (Models with navigation system)

### To Load a Disc

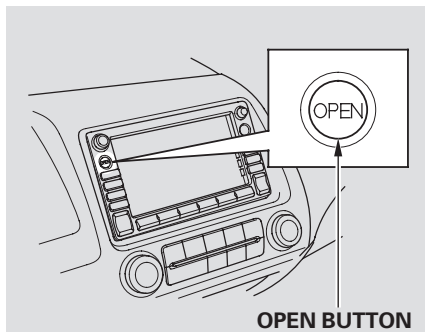

The disc player is behind the navigation screen. To use the disc player, press the OPEN button beside the screen. The screen folds back, and the disc player appears.

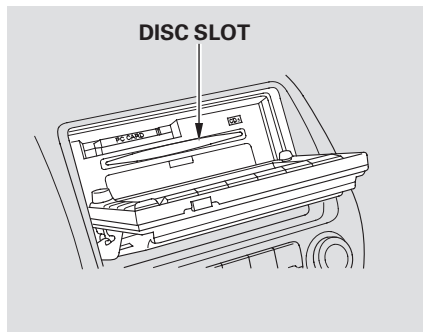

Insert a disc about halfway into the disc slot. The drive will pull the disc in the rest of the way and begin to play it.

You cannot load and play 3-inch (8-cm) discs in this system.

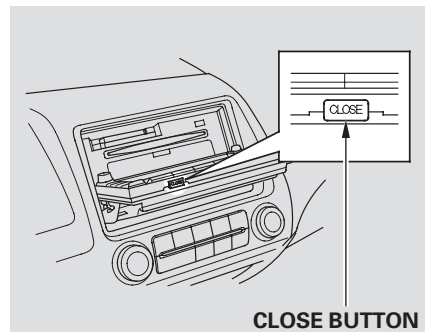

To return the screen to the upright position, press the CLOSE button on the edge of the screen panel. Do not use the folded screen as a tray. If you put a cup, for example, on the screen, the liquid inside the cup may spill on the screen when you go over a bump.

Push the AUDIO button beside the screen to show the audio display and operate the disc player.

You can also operate the audio system without using the control icons on the audio screen. Press the CD button. The status bar appears on the bottom of the screen. On the navigation screen, you can see the audio information whenever you touch the AUDIO INFO icon on the lower of the screen.

When playing a CD recorded with text data, the track, album, and artist name are shown on the audio display. When playing a disc in MP3 or WMA, the folder number and name, the file number and name, the artist name, and the elapsed time are shown. The system will continuously play a disc until you change modes. If the disc was not recorded with text data, it will not be displayed.

## To Change or Select Tracks/Files

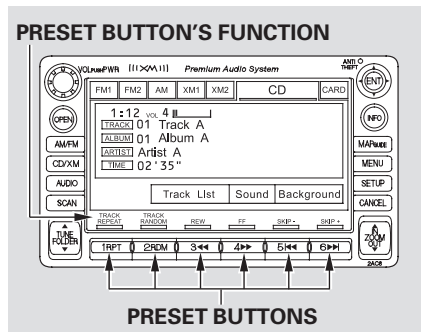

You can use the preset buttons while a disc is playing to select passages and change tracks (files in MP3 or WMA mode). Each preset button's function is shown on the bottom of the screen.

You can also select an icon with the joystick. Move it to left, right, up, or down to change the highlighting and scroll through lists. Then press the ENT on the top of the joystick to select the icon.

**SKIP** – Each time you press and release ►► (preset 6), the player skips forward to the beginning of the next track (file in MP3 or WMA mode). Press and release ◀◀ (preset 5), to skip backward to the beginning of the current track. Press it again to skip to the beginning of the previous track.

**FF/REW** – To move rapidly within a track/file, press and hold ►► (preset 4) or ◀◀ (preset 3).

CONTINUED

## SCAN (TRACK/FILE SCAN) —

The scan function samples all tracks (files in MP3 or WMA) in the order they were recorded. To activate scan, press and release the SCAN button. You will see TRACK SCAN in the display. You will get a 10 second sampling of each track/file on the disc. Press and hold the SCAN button for 2 seconds to get out of scan mode and play the last track/file sampled.

Pressing either SKIP button (preset 5 or 6) also turns off scan.

*In MP3 or WMA mode*

**FOLDER SCAN** — This feature, when activated, samples all the first files in each folder on the disc in order. To activate folder scan, press and hold the SCAN button. You will see FOLDER SCAN in the display.

The system plays the first file in each folder for about 10 seconds. If you do nothing, the system then plays the first file in each folder for 10 seconds each. After playing the first file of the last folder, the system goes to normal playing.

Pressing either SKIP button (preset 5 or 6), or selecting a different folder with the TUNE bar, or pressing the SCAN button, also turns off folder scan.

## Using a Track List

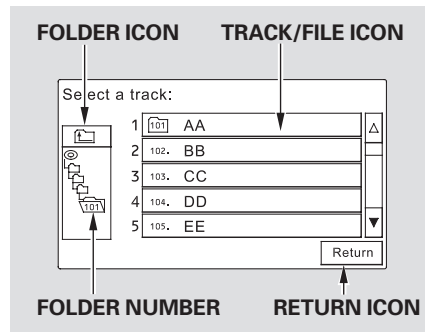

You can also select a track/file directly from a track list on the audio display. Press the AUDIO button to show the audio display, then touch the Track List icon. The track list menu appears on the display.

CONTINUED

When playing a CD recorded with text data, each track name is shown in the audio display. With a disc recorded in MP3 or WMA, the folder number and the location are also displayed.

If the disc was not recorded with text data, only the track number is shown.

To scroll through the display, touch the ▲ or ▼ icon on the side of the screen. To go back to the previous display, touch the Return icon on the screen.

Select the desired track by touching the icon on the display. The selected icon will be highlighted in blue. The system begins to play the selected track or file. With a disc in MP3 or WMA, touch the folder icon on the upper left of the screen to move to the parent folder. The current folder is highlighted in blue.

### **To Stop Playing a Disc**

To play the radio when a disc is playing, press the AM/FM button or touch the FM1, FM2, AM, XM1, or XM2 icon. If a PC card is in the audio unit, touch the CARD icon to play the PC card. Press the CD button again or touch the CD icon to switch back to the disc player.

If you turn the system off while a disc is playing, either with the power/volume knob or by turning off the ignition switch, the disc will stay in the drive. When you turn the system back on, the disc will begin playing where it left off.

### ***Removing a Disc***

To remove a disc from the audio unit, fold back the screen by pressing the OPEN button (see page 148). Press the eject button (▲) to remove the disc. If you eject the disc, but do not remove it from the slot, the system will automatically reload it after 10 seconds and put it in pause mode. To begin playing, press the CD button.

To return the screen to the upright position, press the CLOSE button.

You cannot close the screen if a disc is partially inserted into its slot.

You can also eject the disc when the ignition switch is off.

## Operating the Optional Disc Changer

An optional six or eight disc changer is available for your vehicle. This disc changer uses the same controls used for the in-dash disc player or the radio.

Load the desired discs in the magazine, and load the magazine in the changer according to the instructions that came with the unit.

To select the disc changer, press the CD/AUX button. The disc and track numbers will be displayed. To select a different disc, use either side of the TUNE bar. To select the previous disc, press the ▲ side. To select the next disc, press the ▼ side.

If you select an empty slot in the magazine, the changer will search for the next available disc to load and play.

## Protecting Discs

For information on how to handle and protect discs, see page [169](#).

## Playing a PC Card

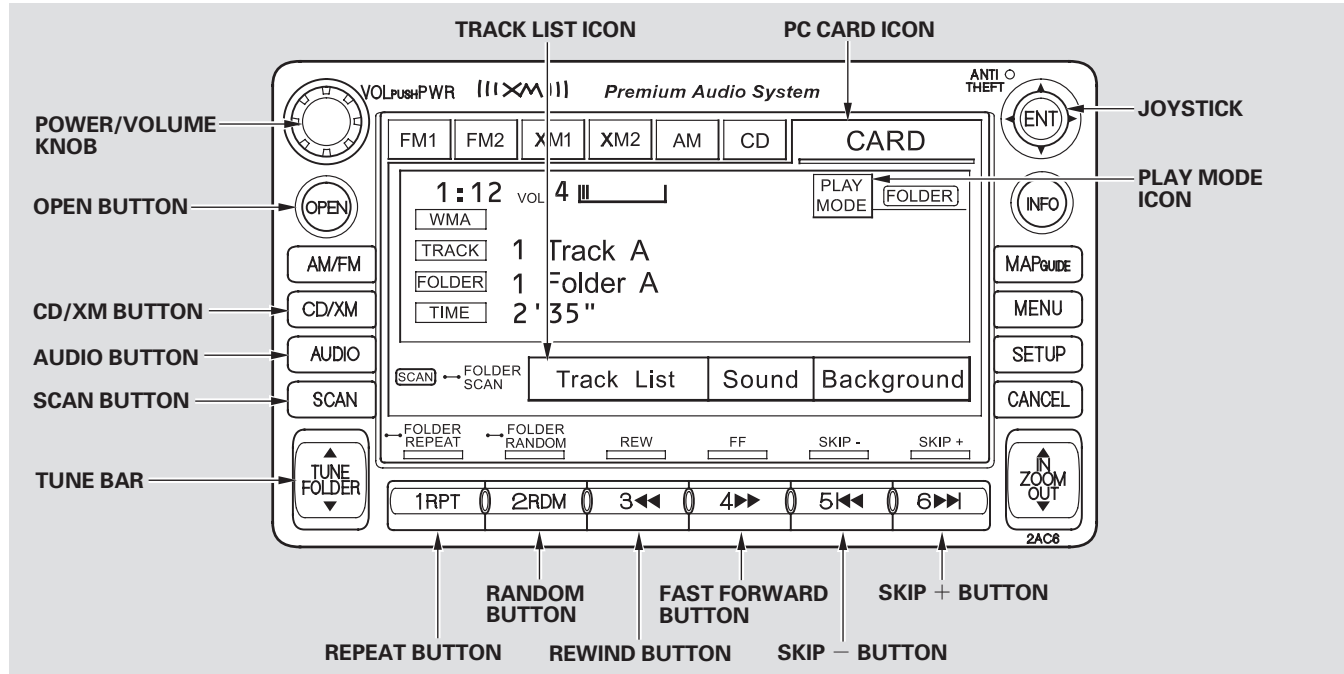



## Audio System (Models with navigation system)

---

### To Play a PC card

You operate the PC card player with the same controls used for the radio and the disc player. To load or play a card, the ignition switch must be in the ACCESSORY (I) or ON (II) position.

The PC card player reads and plays cards in MP3 or WMA formats. Depending on the format, the screen will indicate “MP3” or “WMA” when a card is playing. The card limit of the player is 99 folders and 999 tracks. If the card has a complex structure, it takes some time for the system to begin playing it.

Based on PCMCIA 2.1/JEIDA 4.2, the recommended PC cards for the PC card reader are:

CompactFlash  
Flash ATA  
SD memory card

Always use the recommended memory card with the appropriate adapter (if an adapter is needed). Some memory cards will not work in this unit.

### NOTE:

- When you insert a PC card into the slot, make sure you put it in straight. If you cannot insert it, remove it, and insert again.
- Do not keep PC cards in the vehicle. Direct sunlight and high heat will damage them.
- To avoid damaging the card reader, do not insert hard disc drive cards into the PC card slot.
- You cannot close the screen (move it to the upright position) until the PC card is inserted all the way into its slot or removed.

- Never insert foreign objects into the PC card slot.

The specifications for compatible MP3 files are:

- Sampling frequency:
  - 32/44.1/48 kHz (MPEG1)
  - 24/22.05/16 kHz (MPEG2)
- Bit rate: 32/40/48/56/64/80/96/112/128/160/192/224/256/320 kbps (MPEG1)
  - 8/16/24/32/40/48/56/64/80/96/112/128/160 kbps (MPEG2)
- Compatible with variable bit rate and multi-session
- Maximum layers (including ROOT): 8 layers

The specifications for compatible WMA files are:

- Sampling frequency: 32/44.1/48 kHz
- Bit rate: 48/64/80/96/128/160/192 kbps
- Compatible with variable bit rate and multi-session
- Maximum layers (including ROOT): 8 layers

In WMA format, DRM (digital rights management) files cannot be played. If the system finds a DRM file, it skips that file and plays the next available folder or file.

### *Loading a PC Card*

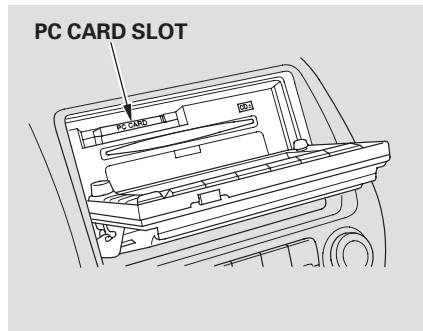

The PC card slot is behind the navigation screen. To use the PC card player, press the OPEN button beside the screen. The screen folds back, and the PC card slot appears.

Insert a PC card straight into the slot. The drive will read the PC card and begin to play it.

Return the screen to the upright position by pressing the CLOSE button on the edge of the screen panel.

Push the AUDIO button beside the screen to show the audio display and operate the PC card player.

You can also operate the audio system without using the control icons on the audio screen. Press any of the appropriate control buttons. The status bar appears on the bottom of the screen. On the navigation screen, you can see the audio information whenever you touch the AUDIO INFO icon on the screen.

*CONTINUED*

# Audio System (Models with navigation system)

There are three play modes: Folder, Artist, and Album. Touch the PLAY MODE icon, then choose one of the modes by touching its icon. When a mode is selected, it is highlighted in blue.

- Folder mode plays tracks in the order they were added to the card.
- Artist mode plays tracks in alphabetical order, by artist and song title.
- Album mode plays albums (folders) in alphabetical order.

If play mode information was not included in the tracks when they were added to the card, it will not be displayed on the screen.

## To Select a Play Mode

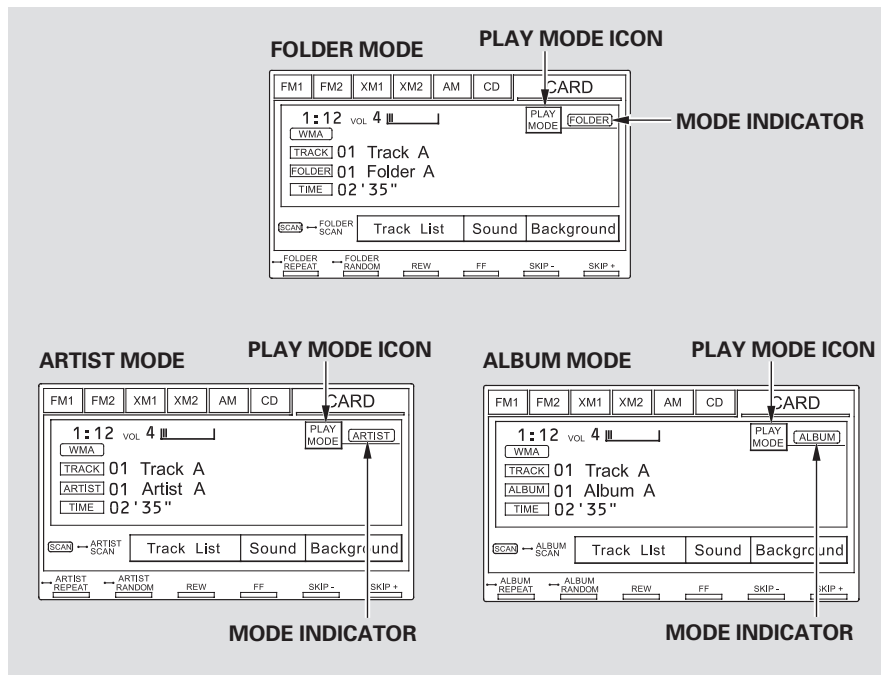

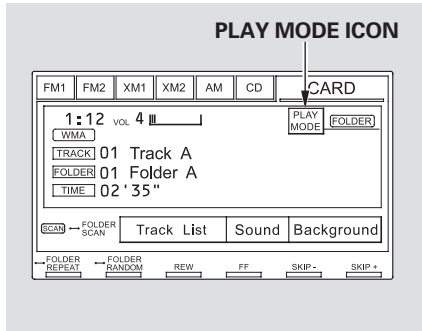

To select a play mode, push the AUDIO button to show the audio display, then touch the PLAY MODE icon on the display.

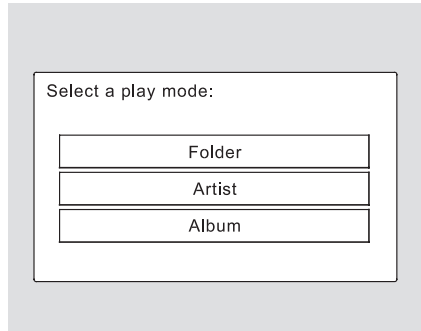

Select the desired mode by touching the appropriate icon, or move the joystick, then press the ENT.

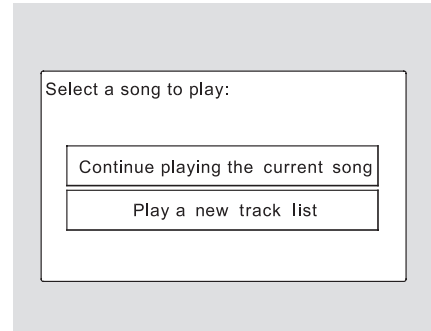

After you select the play mode, the display changes to the selectable playing menu. If you select "Continue playing the Current Song," the system goes into the selected play mode after playing the current file.

CONTINUED

## Searching for a Song Title by Keyword

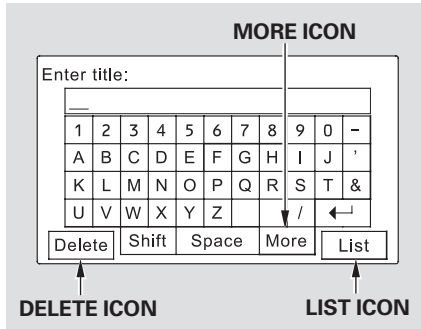

In Title by Keyword mode, enter the title name, or any keyword, by touching the letter icons on the screen. Press the List icon to begin the song search. If you press the CANCEL button on the screen, the display returns to the mode menu without doing a search.

To cancel the selected letter, select the letter and touch the Delete icon. To select more characters, touch the More icon. The other character list will be shown.

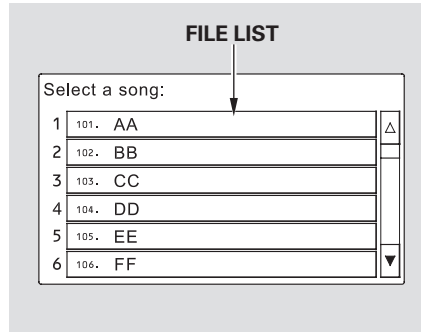

After the system searches for a song, a file list is displayed. To scroll through the list, touch the ▲ or ▼ icon on the side of the screen. Select the desired file by touching the appropriate icon, or moving the joystick and pressing the ENT.

## Searching for a Song by Artist Name

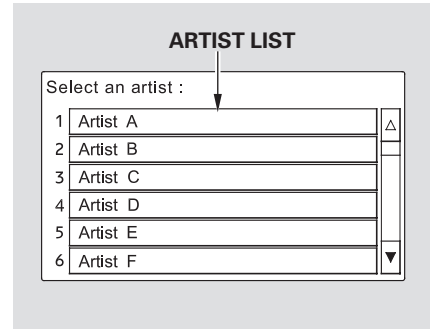

Select the Artist icon, and the artist list appears. Select the desired artist, and the artist's file list is displayed.

CONTINUED

## Searching for a Song by Album Name

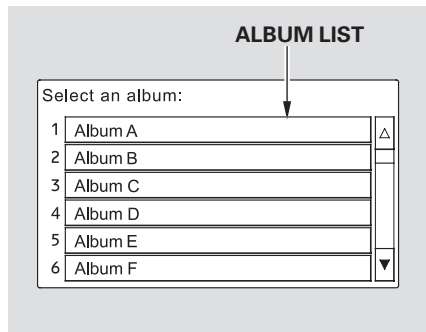

Select the Album icon, and the album list appears. Select the desired album, and its song list is displayed. You can then select the desired song from the list.

## To Stop Playing a PC card

To play the radio when a PC card is playing, press the AM/FM button or touch the FM1, FM2, AM, XM1, or XM2 icon. If a disc is in the audio unit, press the CD button or touch the CD icon to play the disc. Touch the CARD icon to switch back to the PC card player.

If you turn the system off while a PC card is playing, either with the power/volume knob or by turning off the ignition switch, the card will stay in the drive. When you turn the system back on, the card will begin playing where it left off.

When you leave the vehicle, always remove the PC card from the audio unit.

## Removing a PC Card

To remove a PC card from the audio unit, fold back the screen by pressing the OPEN button (see page 148). Press the eject button (▲) to remove the card. If you do not remove it from the slot, you cannot return the screen to the upright position.

To return the screen to the upright position, press the CLOSE button.

You can also eject a card when the ignition switch is off.

## PC Card Player Malfunction

If there is a problem with the PC card player, see your dealer.

## Radio Frequencies

The radio can receive the complete AM and FM bands. Those bands cover these frequencies:

AM band: 530 to 1,710 kilohertz

FM band: 87.7 to 107.9 megahertz

Radio stations on the AM band are assigned frequencies at least 10 kilohertz apart (530, 540, 550).

Stations on the FM band are assigned frequencies at least 0.2 megahertz apart (87.9, 88.1, 88.3).

Stations must use these exact frequencies. It is fairly common for stations to round-off the frequency in their advertising, so your radio could display a frequency of 100.9 even though the announcer may identify the station as "FM101."

## Radio Reception

How well the radio receives stations is dependent on many factors, such as the distance from the station's transmitter, nearby large objects, and atmospheric conditions.

A radio station's signal gets weaker as you get farther away from its transmitter. If you are listening to an AM station, you will notice the sound volume becoming weaker, and the station drifting in and out. If you are listening to an FM station, you will see the stereo indicator flickering off and on as the signal weakens. Eventually, the stereo indicator will go off and the sound will fade completely as you get out of range of the station's signal.

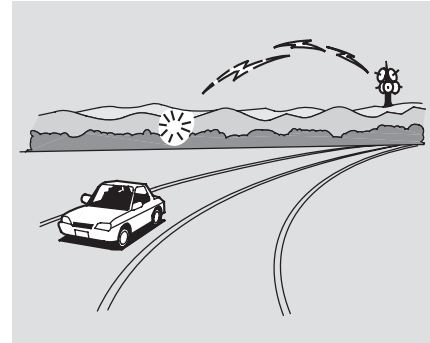

Driving very near the transmitter of a station that is broadcasting on a frequency close to the frequency of the station you are listening to can also affect your radio's reception. You may temporarily hear both stations, or hear only the station you are close to.

*CONTINUED*

## AM/FM Radio Reception

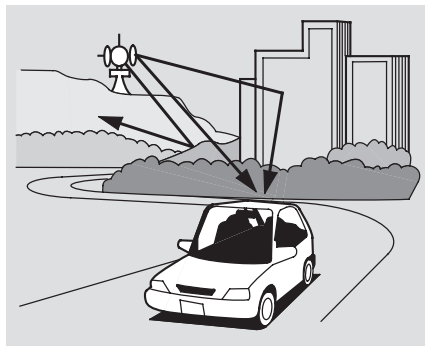

Radio signals, especially on the FM band, are deflected by large objects such as buildings and hills. Your radio then receives both the direct signal from the station's transmitter, and the deflected signal. This causes the sound to distort or flutter. This is a main cause of poor radio reception in city driving.



Radio reception can be affected by atmospheric conditions such as thunderstorms, high humidity, and even sunspots. You may be able to receive a distant radio station one day and not receive it the next day because of a change in conditions.

Electrical interference from passing vehicles and stationary sources can cause temporary reception problems.

*As required by the FCC:  
Changes or modifications not expressly  
approved by the party responsible for  
compliance could void the user's  
authority to operate the equipment.*



## General Information

- When using CD-R or CD-RW discs, use only high quality discs labeled for audio use.
- When recording a CD-R or CD-RW, the recording must be closed for it to be used by the system.
- Play only standard round discs. Odd-shaped discs may jam in the drive or cause other problems.
- Handle your discs properly to prevent damage and skipping.

### NOTICE

*Do not use discs with adhesive labels. The label can curl up and cause the disc to jam in the unit.*

## Protecting Discs

When a disc is not being played, store it in its case to protect it from dust and other contamination. To prevent warpage, keep discs out of direct sunlight and extreme heat.

To clean a disc, use a clean soft cloth. Wipe across the disc from the center to the outside edge.

A new disc may be rough on the inner and outer edges. The small plastic pieces causing this roughness can flake off and fall on the recording surface of the disc, causing skipping or other problems. Remove these pieces by rubbing the inner and outer edges with the side of a pencil or pen.

Never try to insert foreign objects in the system or the magazine.

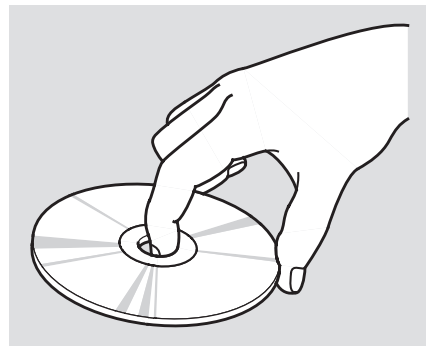

Handle a disc by its edges; never touch either surface. Do not place stabilizer rings or labels on the disc. These, along with contamination from fingerprints, liquids, and felt-tip pens, can cause the disc to not play properly, or possibly jam in the drive.

# Remote Audio Controls

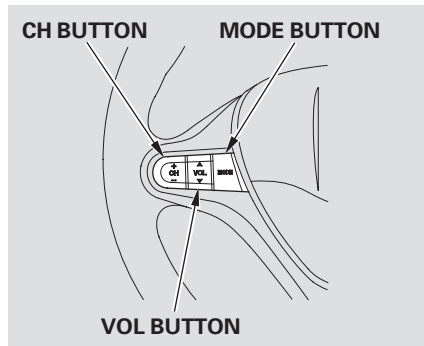

## *If equipped*

Three controls for the audio system are mounted in the steering wheel hub. These let you control basic functions without removing your hand from the wheel.

The VOL button adjusts the volume up (▲) or down (▼). Press the top or bottom of the button, hold it until the desired volume is reached, then release it.

The MODE button changes the mode. Pressing the button repeatedly selects FM1, FM2, AM, disc (if a disc is loaded), or a PC card (if it is loaded). On models with satellite radio system, you can also select XM radio.

If you are listening to the radio, use the CH button to change stations. Each time you press and release the top (+) of the button, the system goes to the next preset station on the band you are listening to. Press and release the bottom (–) to go back to the previous station.

To activate the seek function, press and hold the top (+) or bottom (–) of the CH button until you hear a

beep. The system searches up or down from the current frequency to find a station with a strong signal.

If you are playing a disc, the system skips to the beginning of the next track (file in MP3 or WMA format) each time you press the top (+) of the CH button. Press the bottom (–) to return to the beginning of the current track or file. Press it twice to return to the previous track or file.

You will see the track/file number and the elapsed time. If the disc has text data or is compressed in MP3 or WMA, you can also see any other information (track title, file name, folder name, etc.).

## Remote Audio Controls, Playing an Optional Audio Unit

---

If you are playing a PC card, press the top (+) of the CH button to advance to the next file. Press the bottom (-) to go back to the previous file.

In MP3 or WMA mode, you can use the seek function to select folders. Press and hold the top (+) of the CH button until you hear a beep, to skip forward to the first file of the next folder. Press the bottom (-) to skip backward to the previous folder.

### **Auxiliary Input Jack**

The auxiliary input jack is underneath the accessory power socket on the front panel. The system will accept auxiliary input from standard audio accessories.

When a compatible audio unit is connected to the jack, press the AUX button to select it.

# Radio Theft Protection

---

*U.S. LX, EX, Si and all Canadian models*

Your vehicle's audio system will disable itself if it is disconnected from electrical power for any reason. To make it work again, the user you must enter a specific code with the preset buttons (icons on vehicles with navigation system). Because there are hundreds of number combinations possible, making the system work without knowing the exact code is nearly impossible.

You should have received a card that lists your audio system's code and serial numbers. It is best to store this card in a safe place at home. In addition, you should write the audio system's serial number in this owner's manual.

If you lose the card, you must obtain the code number from a dealer. To do this, you will need the system's serial number.

If your vehicle's battery is disconnected or goes dead, or the radio fuse is removed, the audio system will disable itself. If this happens, you will see "ENTER CODE" in the frequency display the next time you turn on the system. Use the preset buttons (icons on vehicles with navigation system) to enter the code. The code is on the radio code card included in your owner's manual kit. When it is entered correctly, the radio will start playing.

If you make a mistake entering the code, do not start over; complete the sequence, then enter the correct code. You have 10 tries to enter the correct code. If you are unsuccessful in 10 attempts, you must then leave the system on for 1 hour before trying again.

*On models without navigation system*

If your vehicle's battery is disconnected or goes dead, you will need to set the clock.

To set the time, press the **CLOCK** (AM, AM/FM) button until the displayed time begins to blink, then release the button.

Change the hours by pressing the **H** (preset 1) button until the numbers advance to the desired time. Change the minutes by pressing the **M** (preset 2) button until the numbers advance to the desired time.

Press the **CLOCK** (AM, AM/FM) button again to enter the set time.

You can quickly set the time to the nearest hour. If the displayed time is before the half hour, pressing the **CLOCK** (AM, AM/FM) button until you hear a beep, then pressing the **R** (preset 3) button sets the clock back

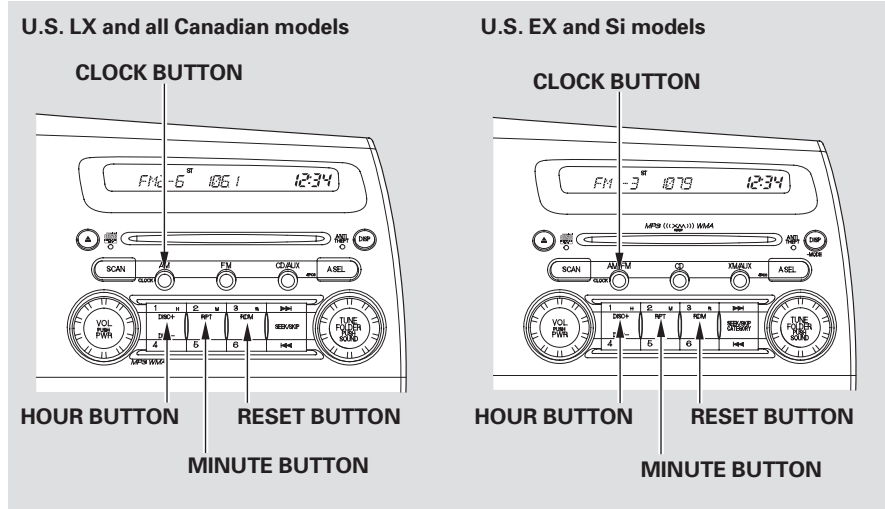

to the previous hour. If the displayed time is after the half hour, the clock sets forward to the beginning of the next hour.

For example: 1:06 will reset to 1:00  
1:52 will reset to 2:00

*On models with navigation system*  
The navigation system receives signals from the global positioning system (GPS), and the displayed time is updated automatically by the GPS. Refer to the navigation system manual for how to adjust the time.

## Security System

### *If equipped*

The security system helps to protect your vehicle and valuables from theft. The horn sounds and a combination of headlights, parking lights, side marker lights, and taillights flashes if someone attempts to break into your vehicle or remove the radio. This alarm continues for 2 minutes, then the system resets. To reset an alarming system before the 2 minutes have elapsed, unlock the driver's door with the key or the remote transmitter.

The security system automatically sets 15 seconds after you lock the doors, hood, and trunk. For the system to activate, you must lock the doors from the outside with the key, lock tab, door lock switch, or remote transmitter. The security system indicator on the instrument panel starts blinking immediately to show you the system is setting itself.

### SECURITY SYSTEM INDICATOR

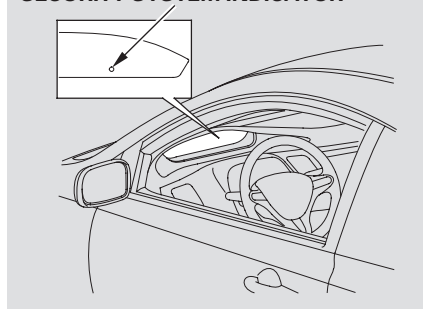

Once the security system is set, opening either door without using the key or the remote transmitter, the hood, or the trunk will cause the system to alarm. It also alarms if the radio is removed from the dashboard or the wiring is cut.

With the system set, you can still open the trunk with the master key (U.S. LX model) or the remote transmitter (U.S. EX and Si models) without triggering the alarm. The

alarm will sound if the trunk lock is forced, or the trunk is opened with the trunk release handle or the emergency trunk opener.

The security system will not set if the hood, trunk, or either door is not fully closed. If the system will not set, check the door and trunk open indicators on the instrument panel (see page 61), to see if the doors and the trunk are fully closed. Since it is not part of the monitor display, manually check the hood.

**NOTE:** Use the remote transmitter to quickly check that the hood, the trunk, and both doors are closed. Push the lock button twice within 5 seconds. There should be an audible confirmation beep.

Do not attempt to alter this system or add other devices to it.

*If equipped*

Cruise control allows you to maintain a set speed above 25 mph (40 km/h) without keeping your foot on the accelerator pedal. It should be used for cruising on straight, open highways. It is not recommended for city driving, winding roads, slippery roads, heavy rain, or bad weather.

**⚠ WARNING**

Improper use of the cruise control can lead to a crash.

Use the cruise control only when traveling on open highways in good weather.

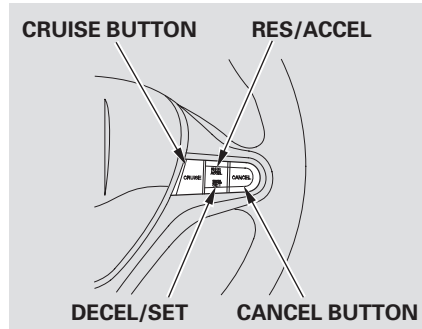
**Using Cruise Control**

1. Push the CRUISE button on the steering wheel. The CRUISE MAIN indicator on the instrument panel comes on.
2. Accelerate to the desired cruising speed above 25 mph (40 km/h).

3. Press and release the DECEL/SET button on the steering wheel. The CRUISE CONTROL indicator on the instrument panel comes on to show the system is now activated.

Cruise control may not hold the set speed when you are going up and down hills. If your speed increases going down a hill, use the brakes to slow down. This will cancel the cruise control. To resume the set speed, press the RES/ACCEL button. The CRUISE CONTROL indicator on the instrument panel will come back on.

When climbing a steep hill, the automatic transmission may downshift to hold the set speed.

CONTINUED

# Cruise Control

---

## Changing the Set Speed

You can increase the set cruising speed in any of these ways:

- Press and hold the RES/ACCEL button. When you reach the desired cruising speed, release the button.
- Push on the accelerator pedal until you reach the desired cruising speed, then press the DECEL/SET button.
- To increase the speed in very small amounts, tap the RES/ACCEL button. Each time you do this, your vehicle speeds up about 1 mph (1.6 km/h).

You can decrease the set cruising speed in any of these ways:

- Press and hold the DECEL/SET button. Release the button when you reach the desired speed.
- To slow down in very small amounts, tap the DECEL/SET button. Each time you do this, your vehicle slows down about 1 mph (1.6 km/h).
- Tap the brake or clutch pedal lightly with your foot. The CRUISE CONTROL indicator on the instrument panel goes out. When the vehicle slows to the desired speed, press the DECEL/SET button.

Even with the cruise control turned on, you can still use the accelerator pedal to speed up for passing. After completing the pass, take your foot off the accelerator pedal. The vehicle will return to the set cruising speed.

Resting your foot on the brake or clutch pedal causes the cruise control to cancel.



## **Cancelling Cruise Control**

You can cancel cruise control in any of these ways:

- Tap the brake or clutch pedal.
- Push the CANCEL button on the steering wheel.
- Push the CRUISE button on the steering wheel.

## **Resuming the Set Speed**

When you push the CANCEL button, or tap the brake or clutch pedal, the system remembers the previously set cruising speed. To return to that speed, accelerate to above 25 mph (40 km/h) and then press and release the RES/ACCEL button. The CRUISE CONTROL indicator comes on, and the vehicle accelerates to the same cruising speed as before.

Pressing the CRUISE button turns the system off and erases the previous cruising speed.

Before you begin driving your vehicle, you should know what gasoline to use and how to check the levels of important fluids. You also need to know how to properly store luggage or packages. The information in this section will help you. If you plan to add any accessories to your vehicle, please read the information in this section first.

Break-in Period .....	180
Fuel Recommendation .....	180
Service Station Procedures .....	181
Refueling.....	181
Opening and Closing the Hood .....	182
Oil Check .....	183
Engine Coolant Check .....	185
Fuel Economy .....	185
Accessories and Modifications ....	186
Carrying Cargo .....	188

# Break-in Period, Fuel Recommendation

---

## Break-in Period

Help assure your vehicle's future reliability and performance by paying extra attention to how you drive during the first 600 miles (1,000 km). During this period:

- Avoid full-throttle starts and rapid acceleration.
- Do not change the oil until the scheduled maintenance time.
- Avoid hard braking for the first 200 miles (300 km).

You should also follow these recommendations with an overhauled or exchanged engine, or when the brakes are replaced.

## Fuel Recommendation

### *All models except Si*

Your vehicle is designed to operate on unleaded gasoline with a pump octane number of 87 or higher. Use of a lower octane gasoline can cause a persistent, heavy, metallic rapping noise that can lead to engine damage.

### *Si model only*

Your vehicle is designed to operate on premium unleaded gasoline with a pump octane of 91 or higher. Use of a lower octane gasoline can cause occasional metallic knocking noises in the engine and will result in decreased engine performance. Use of a gasoline with a pump octane less than 87 can lead to engine damage.

We recommend using quality gasolines containing detergent additives that help prevent fuel system and engine deposits.

In addition, in order to maintain good performance, fuel economy, and emissions control, we strongly recommend, in areas where it is available, the use of gasoline that does NOT contain manganese-based fuel additives such as MMT.

Use of gasoline with these additives may adversely affect performance, and cause the malfunction indicator lamp on your instrument panel to come on. If this happens, contact your authorized dealer for service.

Some gasoline today is blended with oxygenates such as ethanol or MTBE. Your vehicle is designed to operate on oxygenated gasoline containing up to 10% ethanol by volume and up to 15% MTBE by volume. Do not use gasoline containing methanol.

If you notice any undesirable operating symptoms, try another service station or switch to another brand of gasoline.

For further important fuel-related information, please refer to your **Quick Start Guide**.

### *On Si model*

You may hear a knocking noise from the engine if you drive the vehicle at low engine speed (below about 1,000 rpm) in a higher gear. To stop this, raise the engine speed by shifting to a lower gear.

## Refueling

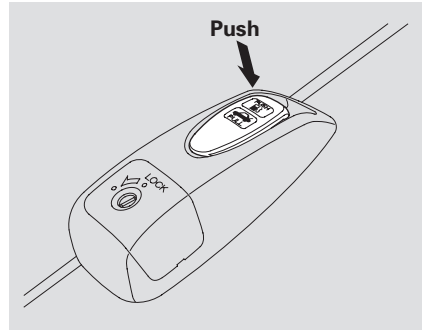

1. Park with the driver's side closest to the service station pump.
2. Open the fuel fill door by pushing on the handle to the left of the driver's seat.

## **⚠ WARNING**

Gasoline is highly flammable and explosive. You can be burned or seriously injured when handling fuel.

- Stop the engine, and keep heat, sparks, and flame away.
- Handle fuel only outdoors.
- Wipe up spills immediately.

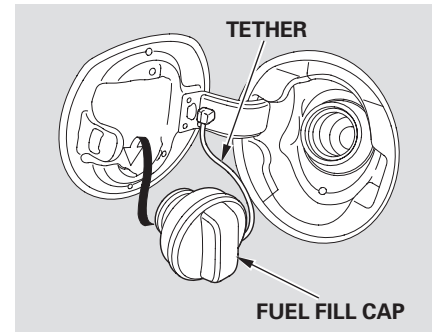

CONTINUED

3. Remove the fuel fill cap slowly. You may hear a hissing sound as pressure inside the tank escapes. The fuel fill cap is attached to the fuel filler with a tether. Place the cap in the holder on the fuel fill door.
4. Stop filling the tank after the fuel nozzle automatically clicks off. Do not try to “top off” the tank. Leave some room for the fuel to expand with temperature changes.

*If the fuel nozzle keeps clicking off even though the tank is not full, there may be a problem with your vehicle’s fuel vapor recovery system. The system helps keep fuel vapors from going into the atmosphere. Try filling at another pump. If this does not fix the problem, consult your dealer.*

5. Screw the fuel fill cap back on until it clicks at least once. If you do not properly tighten the cap, the malfunction indicator lamp may come on (see page 264 ). You will also see a “CHECK FUEL CAP” message on the information display.
6. Push the fuel fill door closed until it latches.

### Opening and Closing the Hood

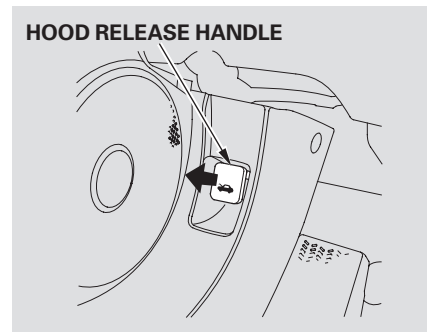

1. Park the vehicle, and set the parking brake. Pull the hood release handle under the lower left corner of the dashboard. The hood will pop up slightly.

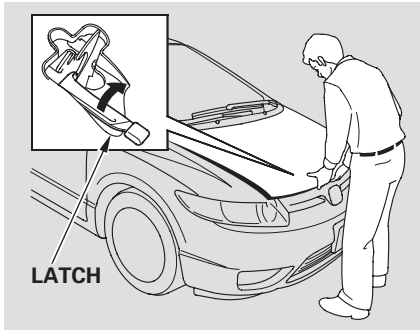

- Put your fingers under the front edge of the hood near the center. Slide your hand to the left until you feel the hood latch handle. Push this handle up to release it. Lift up the hood.

If the hood latch handle moves stiffly, or if you can open the hood without lifting the handle, the mechanism should be cleaned and lubricated.

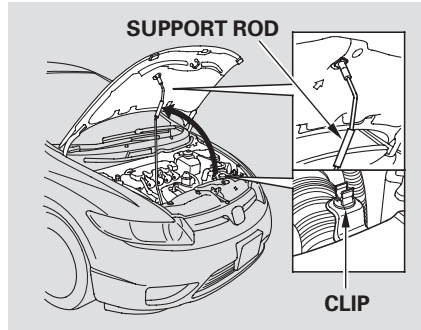

- Pull the support rod out of its clip by holding the grip, and insert the end into the designated hole in the hood.

To close the hood, lift it up slightly to remove the support rod from the hole. Put the support rod back into its holding clip. Lower the hood to about a foot (30 cm) above the fender, then let it drop. Make sure it is securely latched.

## Oil Check

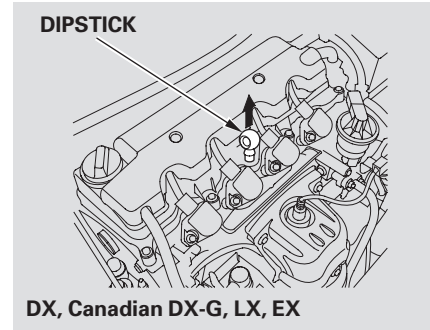

Wait a few minutes after turning the engine off before you check the oil.

- Remove the dipstick (orange handle).
- Wipe off the dipstick with a clean cloth or paper towel.
- Insert it all the way back in its tube.

*CONTINUED*

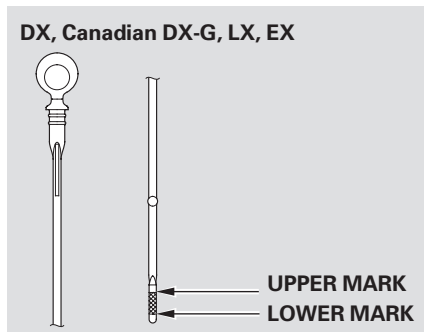
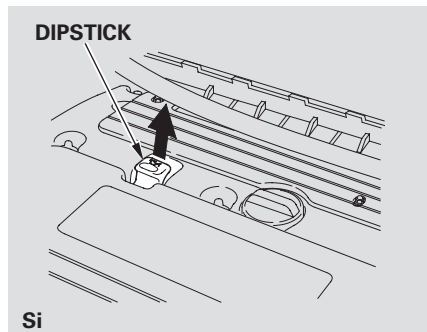

4. Remove the dipstick again, and check the level. It should be between the upper and lower marks.

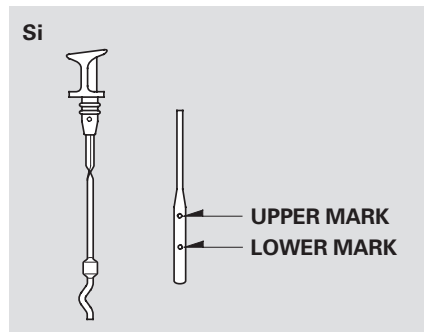

If it is near or below the lower mark, see **Adding Engine Oil** on page [220](#) .

## Engine Coolant Check

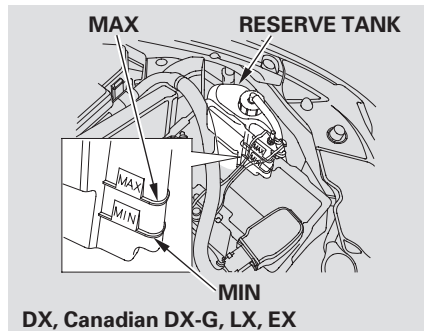

Look at the coolant level in the radiator reserve tank. Make sure it is between the MAX and MIN lines. If it is below the MIN line, see **Adding Engine Coolant** on page 224 for information on adding the proper coolant.

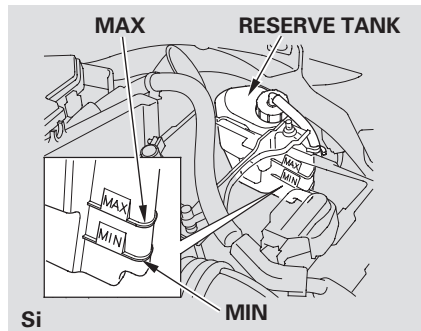

Refer to **Owner's Maintenance Checks** on page 214 for information about checking other items on your vehicle.

## Improving Fuel Economy

- Always maintain your vehicle according to the maintenance minder displayed in the information display. See **Owner's Maintenance Checks** on page 214 .

*For example, an underinflated tire causes more "rolling resistance," which uses more fuel.*

The build-up of snow or mud on your vehicle's underside adds weight and rolling resistance. Frequent cleaning helps your fuel mileage and reduces the chance of corrosion.

- Drive moderately. Rapid acceleration, abrupt cornering, and hard braking use more fuel.
- Always drive in the highest gear possible.

CONTINUED



## Fuel Economy, Accessories and Modifications

- Try to maintain a constant speed. Every time you slow down and speed up, your vehicle uses extra fuel. Use cruise control when appropriate.
- Combine several short trips into one.
- The air conditioning puts an extra load on the engine which makes it use more fuel. Use the fresh-air ventilation when possible.

### Accessories and Modifications

Modifying your vehicle, or installing some non-Honda accessories, can make it unsafe. Before you make any modifications or add any accessories, be sure to read the following information.

### Accessories

Your dealer has Honda accessories that allow you to personalize your vehicle, or improve its performance. These accessories have been designed and approved for your vehicle, and are covered by warranty.

Although non-Honda accessories may fit on your vehicle, they may not meet factory specifications, and could adversely affect your vehicle's handling and stability.

### **WARNING**

Improper accessories or modifications can affect your vehicle's handling, stability, and performance, and cause a crash in which you can be hurt or killed.

Follow all instructions in this owner's manual regarding accessories and modifications.

When properly installed, cellular phones, alarms, two-way radios, and low-powered audio systems should not interfere with your vehicle's computer controlled systems, such as your airbags and anti-lock brakes.

Before installing any accessory:

- Make sure the accessory does not obscure any lights, or interfere with proper vehicle operation or performance.
- Be sure electronic accessories do not overload electrical circuits (see page 266 ) or interfere with the proper operation of your vehicle.
- Before installing any electronic accessory, have the installer contact your dealer for assistance. If possible, have your dealer inspect the final installation.
- Do not install accessories on the side pillars or across the rear windows. In these areas, accessories may interfere with proper operation of the side curtain airbags.

## Modifying Your Vehicle

Removing parts from your vehicle, or replacing components with non-Honda components could seriously affect your vehicle's handling, stability, and reliability.

Some examples are:

- Lowering your vehicle with a non-Honda suspension kit that significantly reduces ground clearance can allow the undercarriage to hit speed bumps or other raised objects, which could cause the airbags to deploy.
- Raising your vehicle with a non-Honda suspension kit can affect the handling and stability.
- Non-Honda wheels, because they are a universal design, can cause excessive stress on suspension components.

- Larger or smaller wheels and tires can interfere with the operation of your vehicle's anti-lock brakes and other systems.
- Modifying your steering wheel or any other part of your vehicle's safety features can make the systems ineffective.

If you plan to modify your vehicle, consult your dealer.

# Carrying Cargo

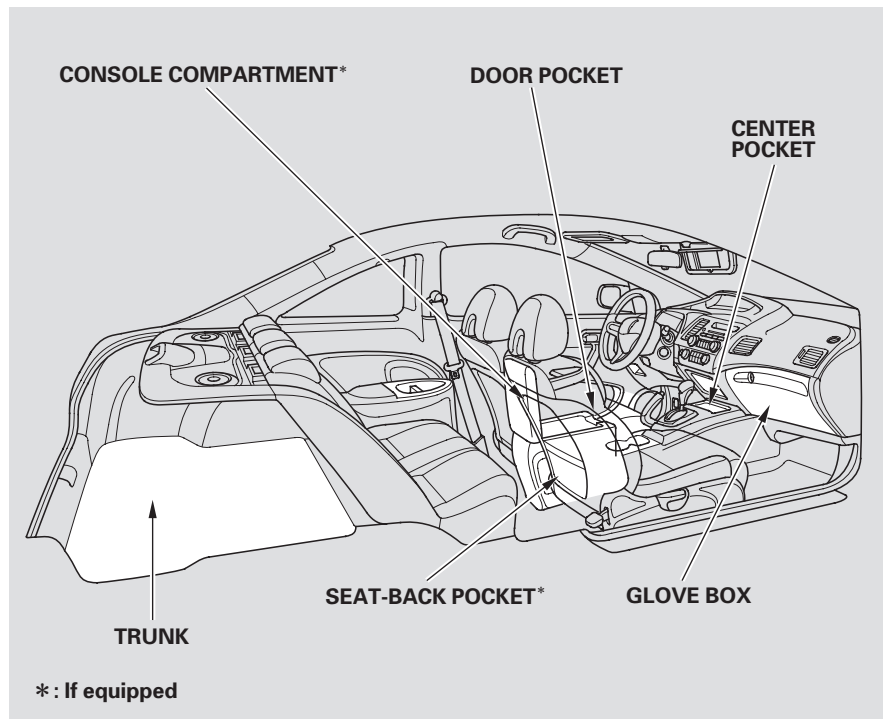

Your vehicle has several convenient storage areas:

- Glove box
- Door and seat-back pockets
- Console compartment
- Center pocket
- Trunk, including the rear seats when folded down

However, carrying too much cargo, or improperly storing it, can affect your vehicle's handling, stability, stopping distance, and tires, and make it unsafe. Before carrying any type of cargo, be sure to read the following pages.

### Load Limits

The maximum load for your vehicle is 850 lbs (385 kg) for U.S. models and 395 kg for Canadian models. This figure includes the total weight of all occupants, cargo, and accessories.

#### **WARNING**

Overloading or improper loading can affect handling and stability and cause a crash in which you can be hurt or killed.

Follow all load limits and other loading guidelines in this manual.

Steps for determining correct load limit:

1. Locate the statement, “the combined weight of occupants and cargo should never exceed 850 lbs” on your vehicle’s placard. [The placard is on the driver’s doorjamb.]
2. Determine the combined weight of the driver and passengers that will be riding in your vehicle.
3. Subtract the combined weight of the driver and passengers from 850 pounds.

4. The resulting figure equals the available amount of cargo and luggage load capacity. For example, if the maximum load is 850 lbs and there will be five 150 lb passengers in your vehicle, the amount of available cargo and luggage load capacity is 100 lbs.  $(850 - 750 (5 \times 150) = 100 \text{ lbs.})$

5. Determine the combined weight of luggage and cargo being loaded in the vehicle. That weight may not safely exceed the available cargo and luggage load capacity in step 4.

In addition, the total weight of the vehicle, all passengers, accessories, and cargo must not exceed the Gross Vehicle Weight Rating (GVWR) or the Gross Axle Weight Rating (GAWR). Both are on a label on the driver’s doorjamb.

# Carrying Cargo

---

## Carrying Items in the Passenger Compartment

- Store or secure all items that could be thrown around and hurt someone during a crash.
- Do not put any items on top of the rear shelf. They can block your view and be thrown around the vehicle during a crash.
- Be sure items placed on the floor behind the front seats cannot roll under the seats and interfere with the driver's ability to operate the pedals, proper operation of the seats, and proper operation of the sensors under the seats.
- Keep the glove box closed while driving. If it is open, a passenger could injure their knees during a crash or sudden stop.

## Carrying Cargo in the Trunk

- Distribute cargo evenly on the floor of the trunk, placing the heaviest items on the bottom and as far forward as possible.
- If you fold down the back seat, tie down items that could be thrown about the vehicle during a crash or sudden stop.
- If you carry large items that prevent you from closing the trunk lid, exhaust gas can enter the passenger area. To avoid the possibility of **carbon monoxide poisoning**, follow the instructions on page [50](#) .

## Cargo Net

### *Optional*

The cargo net can be used to help hold down items stored in the trunk.

This section gives you tips on starting the engine under various conditions, and how to operate the manual and automatic transmissions. It also includes important information on parking your vehicle, and the braking system.

Driving Guidelines .....	192
Preparing to Drive .....	193
Starting the Engine.....	194
Manual Transmission.....	195
Automatic Transmission.....	198
Parking.....	202
Braking System.....	203
Anti-lock Brakes (ABS) .....	204
Towing a Trailer .....	205

# Driving Guidelines

## *Si model*

Your vehicle is designed to give you optimum handling and performance on well-maintained roads. As part of this design, your vehicle has a minimum of ground clearance and very low-profile tires.

- Use caution if you ever drive your vehicle on very rough or rutted roads. You could damage the suspension and underbody by bottoming out. Going too fast over parking lot “speed bumps” can also cause damage.

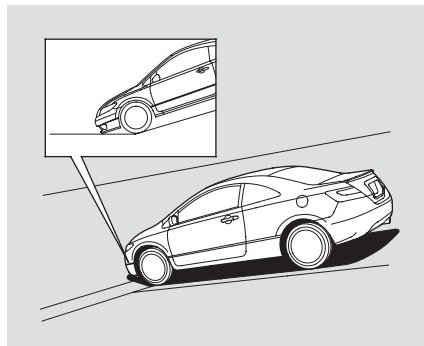

- Curbs and steep inclines could damage the front and rear bumpers. Low curbs that do not affect the average vehicle may be high enough to hit the bumper on your vehicle. The front or rear bumper may scrape when trying to drive onto an incline, such as a steep driveway or trailer ramps.

- Because of the low-profile tires fitted to your vehicle, the alloy wheels are closer to the ground. Driving over a pothole or road debris at too high a speed can seriously damage a wheel. Slow down under these conditions.

You should do the following checks and adjustments before you drive your vehicle.

1. Make sure all windows, mirrors, and outside lights are clean and unobstructed. Remove frost, snow, or ice.
2. Check that the hood is fully closed.
3. Check that the trunk is fully closed.
4. Visually check the tires. If a tire looks low, use a gauge to check its pressure (see page [241](#) ).
5. Check that any items you may be carrying are stored properly or fastened down securely.
6. Check the seat adjustment (see page [90](#) ).
7. Check the adjustment of the inside and outside mirrors (see page [100](#) ).
8. Check the steering wheel adjustment (see page [73](#) ).
9. Make sure the doors are securely closed and locked.
10. Fasten your seat belt. Check that your passengers have fastened their seat belts (see page [14](#) ).
11. When you start the engine, check the gauges and indicators in the instrument panel (see page [55](#) ).



# Starting the Engine

---

1. Apply the parking brake.
2. In cold weather, turn off all electrical accessories to reduce the drain on the battery.
3. **Manual Transmission:**  
Push the clutch pedal down all the way. The START (III) position does not function unless the clutch pedal is pressed.  
  
*Automatic Transmission:*  
Make sure the shift lever is in Park. Press on the brake pedal.
4. Without touching the accelerator pedal, turn the ignition key to the START (III) position. Do not hold the key in the START (III) position for more than 15 seconds at a time. If the engine does not start right away, pause for at least 10 seconds before trying again.

## NOTICE

*The immobilizer system protects your vehicle from theft. If an improperly-coded key (or other device) is used, the engine's fuel system is disabled. For more information, see page 75 .*

5. If the engine does not start within 15 seconds, or starts but stalls right away, repeat step 4 with the accelerator pedal pressed halfway down. If the engine starts, release pressure on the accelerator pedal so the engine does not race.
6. If the engine fails to start, press the accelerator pedal all the way down, and hold it there while starting to clear flooding. If the engine still does not start, return to step 5.

## NOTICE

*The engine is harder to start in cold weather. Also, the thinner air found at altitudes above 8,000 feet (2,400 meters) adds to this problem.*

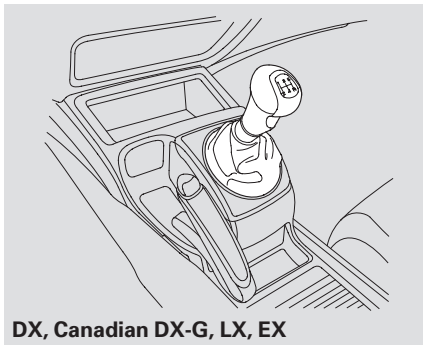

DX, Canadian DX-G, LX, EX

The manual transmission is synchronized in all forward gears for smooth operation. It has a lockout so you cannot shift directly from fifth to reverse.



Si

On vehicles with 6-speed manual transmission, the lockout system prevents you from shifting directly from any forward gear to reverse while the vehicle is moving at a certain speed (see page 197).

When shifting up or down, make sure you push the clutch pedal down all the way, shift to the next gear, and let the pedal up gradually. When you are not shifting, do not rest your foot on the clutch pedal. This can

cause your clutch to wear out faster.

Come to a full stop before you shift into reverse. You can damage the transmission by trying to shift into reverse with the vehicle moving. Push down the clutch pedal, and pause for a few seconds before shifting into reverse, or shift into one of the forward gears for a moment. This stops the gears so they won't "grind."

*On Si model*

**Note:** *The engine can be damaged if you inadvertently downshift into the wrong gear (for example, going from third gear at high rpms to second gear instead of upshifting to fourth gear; the engine speed limiter will not work in this situation).*

CONTINUED

# Manual Transmission

When slowing down, you can get extra braking from the engine by shifting to a lower gear. This extra braking can help you maintain a safe speed and prevent your brakes from overheating while going down a steep hill. Before downshifting, make sure the engine speed will not go into the tachometer's red zone in the lower gear.

## WARNING

Rapid slowing or speeding-up can cause loss of control on slippery surfaces. If you crash, you can be injured.

Use extra care when driving on slippery surfaces.

### *On Si model*

Your vehicle is equipped with an aluminum shift lever. If you leave the vehicle parked outside for a long

time on a hot day, be careful before moving the shift lever. Because of the heat, the shift lever may be extremely hot. If the outside temperature is low, the shift lever feels cold.

### **Recommended Shift Points**

Drive in the highest gear that lets the engine run and accelerate smoothly. This will give you good fuel economy and effective emissions control. The following shift points are recommended:

#### *With 5-speed manual transmission*

Shift up	Normal acceleration
1st to 2nd	15 mph (24 km/h)
2nd to 3rd	27 mph (43 km/h)
3rd to 4th	39 mph (63 km/h)
4th to 5th	53 mph (85 km/h)

#### *With 6-speed manual transmission*

Shift up	Normal acceleration
1st to 2nd	17 mph (27 km/h)
2nd to 3rd	29 mph (47 km/h)
3rd to 4th	37 mph (60 km/h)
4th to 5th	43 mph (69 km/h)
5th to 6th	49 mph (79 km/h)

### Engine Speed Limiter

If you exceed the maximum speed for the gear you are in, the engine speed will enter into the tachometer's red zone. If this occurs, you may feel the engine cut in and out. This is caused by a limiter in the engine's computer controls. The engine will run normally when you reduce the rpm below the red zone.

Before downshifting, make sure the engine will not go into the tachometer's red zone.

#### *On Si model*

Your vehicle has a rev limit indicator to show you when the engine speed is near the tachometer's red zone (see page 60).

### Reverse Lockout

#### *6-speed manual transmission*

The manual transmission has lockout so you cannot accidentally shift from any forward gear to reverse while the vehicle is moving at a certain speed. If you cannot shift to reverse when the vehicle is stopped:

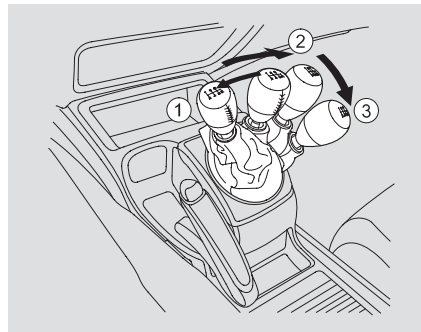

1. With the clutch pedal pressed, move the shift lever to the first/second gear side of the neutral gate, then shift to reverse.

2. If you are still unable to shift to reverse, apply the parking brake, and turn the ignition key to the ACCESSORY (I) or LOCK (0) position.
3. Press the clutch pedal, and shift to reverse.
4. With the clutch pedal still pressed, start the engine.

If you need to use this procedure to shift to reverse, your vehicle may be developing a problem. Have the vehicle checked by your dealer.

# Automatic Transmission

## Shift Lever Position Indicators

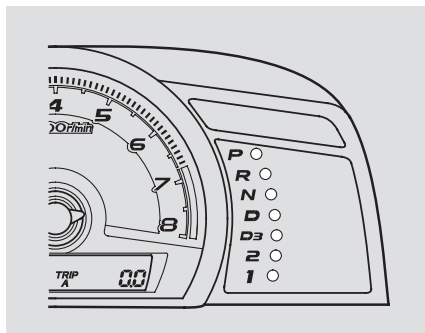

These indicators on the instrument panel show which position the shift lever is in.

The “D” indicator comes on for a few seconds when you turn the ignition switch to the ON (II) position. If it flashes while driving (in any shift position), it indicates a possible problem in the transmission.

If the malfunction indicator lamp comes on along with the “D” indicator, there is a problem in the automatic transmission control system. Avoid rapid acceleration, and have the transmission checked by your dealer as soon as possible.

## Shifting

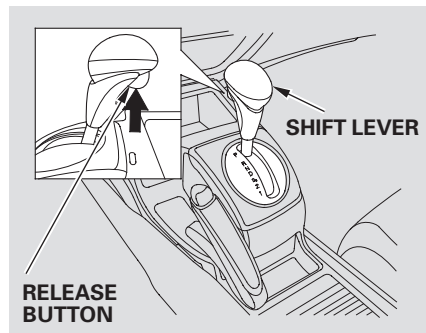

To shift from any position, press firmly on the brake pedal and press the release button on the front of the shift lever. You cannot shift out of Park when the ignition switch is in the LOCK (0) or ACCESSORY (I) position.

To shift from:	Do this:
P to R	Press the brake pedal, and press the shift lever release button.
R to P N to R D <sub>3</sub> to 2 2 to 1	Press the shift lever release button.
1 to 2 2 to D <sub>3</sub> D <sub>3</sub> to D D to N D to D <sub>3</sub> N to D R to N	Move the shift lever.

**Park (P)** — This position mechanically locks the transmission. Use Park whenever you are turning off or starting the engine. To shift out of Park, you must press on the brake pedal and have your foot off the accelerator pedal. Press the release button on the front of the shift lever to move it.

If you have done all of the above and still cannot move the lever out of Park, see **Shift Lock Release** on page 201.

To avoid transmission damage, come to a complete stop before shifting into Park. You must also press the release button to shift into Park. The shift lever must be in Park before you can remove the key from the ignition switch.

**Reverse (R)** — Press the brake pedal and press the release button on the front of the shift lever to shift from Park to reverse. To shift from reverse to neutral, come to a complete stop and then shift. Press the release button before shifting into reverse from neutral.

**Neutral (N)** — Use neutral if you need to restart a stalled engine, or if it is necessary to stop briefly with the engine idling. Shift to the Park position if you need to leave your vehicle for any reason. Press on the brake pedal when you are moving the shift lever from neutral to another gear.

**Drive (D)** — Use this position for your normal driving. The transmission automatically selects a suitable gear (1 through 5) for your speed and acceleration. You may notice the transmission shifting up at higher engine speeds when the engine is cold. This helps the engine warm up faster.

CONTINUED

# Automatic Transmission

---

**Drive (D3)** – This position is similar to D, except only the first three gears are selected. Use D3 to provide engine braking when going down a steep hill. D3 can also keep the transmission from cycling between third and fourth gears in stop-and-go driving.

**Second (2)** – To shift to second, press the release button on the front of the shift lever. This position locks the transmission in second gear. It does not downshift to first gear when you come to a stop.

Use second gear:

- For more power when climbing.
- To increase engine braking when going down steep hills.
- For starting out on a slippery surface or in deep snow.
- To help reduce wheel spin.

**First (1)** – To shift from second to first, press the release button on the front of the shift lever. This position locks the transmission in first gear. By upshifting and downshifting through 1, 2, D3, and D, you can operate the transmission much like a manual transmission without a clutch pedal.

## Engine Speed Limiter

If you exceed the maximum speed for the gear you are in, the engine speed will enter into the tachometer's red zone. If this occurs, you may feel the engine cut in and out. This is caused by a limiter in the engine's computer controls. The engine will run normally when you reduce the rpm below the red zone.

## Shift Lock Release

Do this if pushing on the brake pedal and pressing the release button does not shift the transmission out of Park:

1. Set the parking brake.
2. Remove the key from the ignition switch.

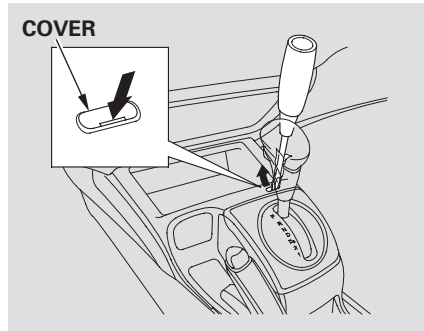

3. Put a cloth on the edge of the shift lock release slot cover. Using a small flat-tipped screwdriver or a

metal fingernail file, carefully pry on the edge of the cover to remove it.

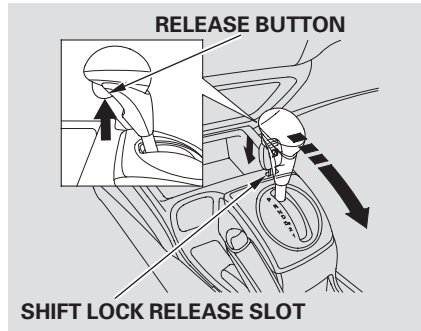

4. Insert the key in the shift lock release slot.
5. Push down on the key while you press the release button on the shift lever and move the lever out of Park to neutral.

6. Remove the key from the shift lock release slot, then install the cover. Make sure the notch on the cover is on the rear. Return the key to the ignition switch, press the brake pedal, and restart the engine.

If you need to use the shift lock release, it means your vehicle is developing a problem. Have it checked by your dealer.



# Parking

---

Always use the parking brake when you park your vehicle. Make sure the parking brake is set firmly, or your vehicle may roll if it is parked on an incline.

If your vehicle has an automatic transmission, set the parking brake before you put the transmission in Park. This keeps the vehicle from moving and putting pressure on the parking mechanism in the transmission.

## Parking Tips

- Make sure the moonroof (if equipped) and the windows are closed.
- Turn off the lights.
- Place any packages, valuables, etc., in the trunk or take them with you.
- Lock the doors.

### *On vehicles with security system*

Check the indicator on the instrument panel to verify that the security system is set.

- Never park over dry leaves, tall grass, or other flammable materials. The hot three way catalytic converter could cause these materials to catch on fire.

- If the vehicle is facing uphill, turn the front wheels away from the curb. If you have a manual transmission, put it in first gear.
- If the vehicle is facing downhill, turn the front wheels toward the curb. If you have a manual transmission, put it in reverse gear.
- Make sure the parking brake is fully released before driving away. Driving with the parking brake partially set can overheat or damage the rear brakes.

## NOTICE

*Never install a sunshade between the upper and lower meters on the instrument panel. If you do, you could cause heat damage to the upper meter on a very hot day.*

Your vehicle is equipped with front disc brakes. The brakes on the rear wheels may be disc or drum, depending on the model. A power assist helps reduce the effort needed on the brake pedal. The ABS helps you retain steering control when braking very hard.

Resting your foot on the pedal keeps the brakes applied lightly, builds up heat, and reduces their effectiveness. It also keeps your brake lights on all the time, confusing drivers behind you.

Constant application of the brakes when going down a long hill builds up heat and reduces their effectiveness. Use the engine to assist the brakes by taking your foot off the accelerator and downshifting to a lower gear.

Check the brakes after driving through deep water. Apply the brakes moderately to see if they feel normal. If not, apply them gently and frequently until they do. Be extra cautious in your driving.

### **Braking System Design**

The hydraulic system that operates the brakes has two separate circuits. Each circuit works diagonally across the vehicle (the left-front brake is connected with the right-rear brake, etc.). If one circuit should develop a problem, you will still have braking at two wheels.

### **Brake Wear Indicators**

If the brake pads need replacing, you will hear a distinctive, metallic screeching sound when you apply the brake pedal. If you do not have the brake pads replaced, they will screech all the time. It is normal for the brakes to occasionally squeal or squeak when you apply them.

## Anti-lock Brakes (ABS)

---

The anti-lock brake system (ABS) helps prevent the brakes from locking up, and helps you retain steering control by pumping the brakes rapidly, much faster than a person can do it.

The ABS also balances the front-to-rear braking distribution according to vehicle loading.

*You should never pump the brake pedal.* Let the ABS work for you by always keeping firm, steady pressure on the brake pedal. This is sometimes referred to as “stomp and steer.”

You will feel a pulsation in the brake pedal when the ABS activates, and you may hear some noise. This is normal: it is the ABS rapidly pumping the brakes. On dry pavement, you will need to press on the brake pedal very hard before the ABS activates. However, you may feel the ABS activate immediately if you are trying to stop on snow or ice.



### ABS Indicator

If this indicator comes on, the anti-lock function of the braking system has shut down. The brakes still work like a conventional system, but without anti-lock. You should have your dealer inspect your vehicle as soon as possible.

If the indicator comes on while driving, test the brakes as instructed on page [265](#).

If the ABS indicator and the brake system indicator come on together, and the parking brake is fully released, the front-to-rear braking distribution system may also be shut down.

Test your brakes as instructed on page [265](#). If the brakes feel normal, drive slowly and have your vehicle repaired by your dealer as soon as possible. Avoid sudden hard braking which could cause the rear wheels to lock up and possibly lead to a loss of control.

## **Important Safety Reminders**

**ABS does not reduce the time or distance it takes to stop the vehicle.** It only helps with the steering control during braking.

**ABS will not prevent a skid that results from changing direction abruptly,** such as trying to take a corner too fast or making a sudden lane change. Always drive at a safe speed for the road and weather conditions.

**ABS cannot prevent a loss of stability.** Always steer moderately when you are braking hard. Severe or sharp steering wheel movement can still cause your vehicle to veer into oncoming traffic or off the road.

**A vehicle with ABS may require a longer distance to stop** on loose or uneven surfaces, such as gravel or snow, than a vehicle without anti-lock. Slow down, and allow a greater distance between vehicles under those conditions.

## **Towing a Trailer**

Your vehicle is not designed to tow a trailer; Attempting to do so can void your warranties.

This section explains why it is important to keep your vehicle well maintained and how to follow basic maintenance safety precautions.

This section also includes instructions on how to read the maintenance minder messages in the information display, a maintenance record, and instructions for simple maintenance tasks you may want to take care of yourself.

If you have the skills and tools to perform more complex maintenance tasks on your vehicle, you may want to purchase the service manual. See page 291 for information on how to obtain a copy, or see your dealer.

Maintenance Safety.....	208
Maintenance Minder.....	209
Maintenance Record.....	216
Fluid Locations.....	218
Adding Engine Oil.....	220
Recommended Engine Oil.....	220
Synthetic Oil.....	221
Engine Oil Additives.....	221
Changing the Oil and Filter.....	222
Engine Coolant.....	224
Windshield Washers.....	227
Automatic Transmission Fluid.....	228
Manual Transmission Fluid.....	229
Brake and Clutch Fluid.....	230
Power Steering Fluid.....	231
Lights.....	232
Cleaning the Seat Belts.....	237
Floor Mats.....	238
Dust and Pollen Filter.....	239
Wiper Blades.....	239
Tires.....	241
Checking the Battery.....	248
Vehicle Storage.....	250

# Maintenance Safety

All service items not detailed in this section should be performed by a certified technician or other qualified mechanic.

## Important Safety Precautions

To eliminate potential hazards, read the instructions before you begin, and make sure you have the tools and skills required.

- Make sure your vehicle is parked on level ground, the parking brake is set, and the engine is off.
- To clean parts, use a commercially available degreaser or parts cleaner, not gasoline.
- To reduce the possibility of fire or explosion, keep cigarettes, sparks, and flames away from the battery and all fuel-related parts.
- Wear eye protection and protective clothing when working with the battery or compressed air.

## WARNING

Improperly maintaining this vehicle, or failing to correct a problem before driving can cause a crash in which you can be seriously hurt or killed.

Always follow the inspection and maintenance recommendations and schedules in this owner's manual.

## Potential Vehicle Hazards

- **Carbon Monoxide poison from engine exhaust.** Be sure there is adequate ventilation whenever you operate the engine.
- **Burns from hot parts.** Let the engine and exhaust system cool before touching any parts.

- **Injury from moving parts.** Do not run the engine unless instructed to do so.

## WARNING

Failure to properly follow maintenance instructions and precautions can cause you to be seriously hurt or killed.

Always follow the procedures and precautions in this owner's manual.

Some of the most important safety precautions are given here. However, we cannot warn you of every conceivable hazard that can arise in performing maintenance. Only you can decide whether or not you should perform a given task.

Your vehicle displays engine oil life and maintenance service items in the information display to show you when you should have your dealer perform engine oil replacement and indicated maintenance service.

Based on the engine operating conditions and accumulated engine revolutions, the onboard computer in your vehicle calculates the remaining engine oil life and displays it as a percentage.

## Engine Oil Life Indicator

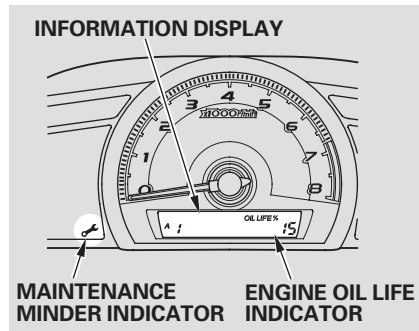

To see the current engine oil life, turn the ignition switch to the ON (II) position, then push and release the SEL/RESET button repeatedly until the engine oil life indicator appears (see page 64 ).

The remaining engine oil life is displayed on the information display according to this table:

Calculated Engine Oil Life (%)	Displayed Engine Oil Life (%)
100 % – 91 %	100 %
90 % – 81 %	90 %
80 % – 71 %	80 %
70 % – 61 %	70 %
60 % – 51 %	60 %
50 % – 41 %	50 %
40 % – 31 %	40 %
30 % – 21 %	30 %
20 % – 16 %	20 %
15 % – 11 % *1	15 %
10 % – 6 % *1	10 %
15 % – 6 % *2	15 %
5 % – 1 %	5 %
0 %	0 %

\* 1: DX and Canadian DX-G

\* 2: LX, EX, and Si

CONTINUED

# Maintenance Minder

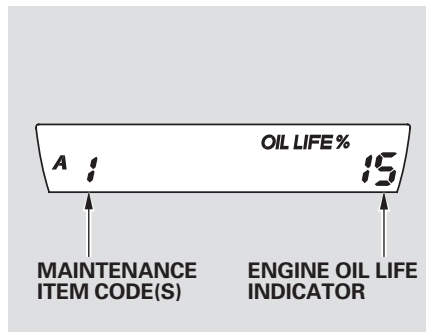

If the oil life is 15 percent or less, you will see the oil life indicator every time you turn the ignition switch to the ON (II) position. The maintenance minder indicator will also come on, and the maintenance item code(s) for other scheduled maintenance items needing service will be displayed next to the engine oil life indicator.

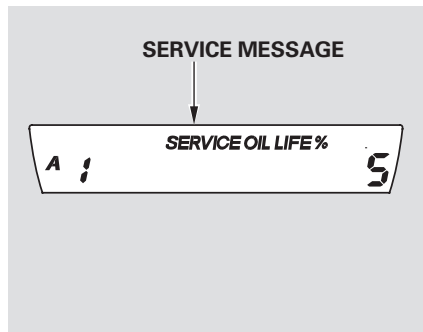

When the remaining engine oil life is less than 5 percent, you will see a "SERVICE" message on the information display, along with the same maintenance item code(s), every time you turn the ignition switch to the ON (II) position.

The maintenance item code or codes indicate the main and sub items required at the time of the oil change (see page 215).

You can switch the display to the odometer, the trip meter, and the outside temperature indicator (if equipped) by pushing the SEL/RESET button on the dashboard repeatedly.



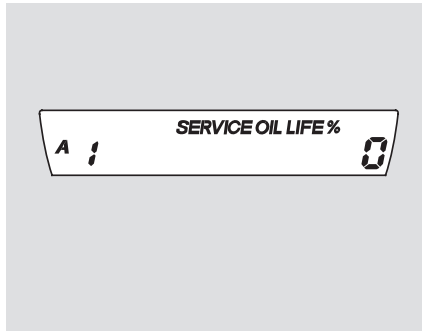

When the remaining engine oil life is 0 percent, you will see the above display. In this display, the remaining oil life indicator will be blinking. This display comes on and stays on every time you turn the ignition switch to the ON (II) position. When you see this message, have the indicated maintenance performed by your dealer as soon as possible.

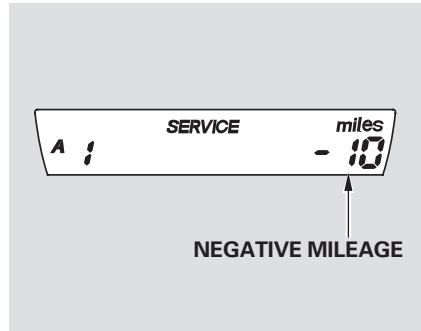

If you still do not perform the indicated maintenance, you will see a negative mileage, for example “- 10,” blinking in the display. This negative mileage means that you should have performed the indicated maintenance 10 miles ago. Immediately have the indicated maintenance done by your dealer.

When the displayed engine oil life is 0 percent or when negative mileage is displayed, the maintenance minder indicator remains on even if you change the display to the odometer and trip meter by pressing the SEL/RESET button.

# Maintenance Minder

## Maintenance Main Items and Sub Items

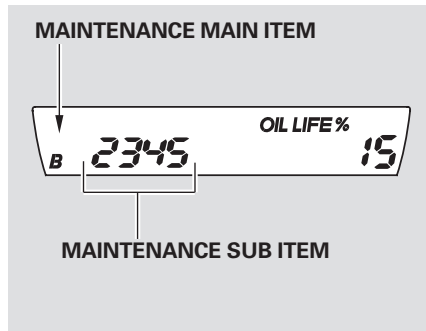

All maintenance items displayed in the information display are in code. For an explanation of these maintenance codes, see page [215](#).

## Resetting the Engine Oil Life Indicator

Your dealer will reset the display after completing the required maintenance service. You will see "OIL LIFE 100 %" on the information display the next time you turn the ignition switch to the ON (II) position.

If maintenance service is done by someone other than your dealer, reset the maintenance minder as follows:

1. Turn the ignition switch to the ON (II) position.
2. Press the SEL/RESET button repeatedly until the engine oil life indicator is displayed.

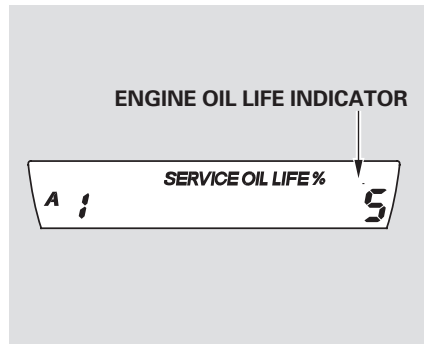

3. Press the SEL/RESET button for about 10 seconds. The engine oil life and the maintenance item code(s) will blink.

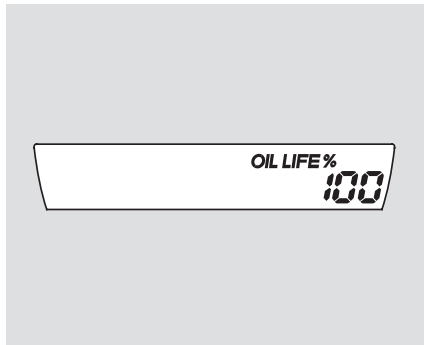

4. Press the SEL/RESET button for more than 5 seconds. The maintenance item code(s) will disappear, and the engine oil life will reset to “100.”

### **Important Maintenance Precautions**

If you have the required service done but do not reset the display, or reset the display without doing the service, the system will not show the proper maintenance intervals. This can lead to serious mechanical problems because you will no longer have an accurate record of when maintenance is needed.

Your authorized Honda dealer knows your vehicle best and can provide competent, efficient service.

However, service at a dealer is not mandatory to keep your warranties in effect. Maintenance may be done by any qualified service facility or person who is skilled in this type of automotive service. Make sure to have the service facility or person reset the display as previously described. Keep all receipts as proof of completion, and have the person who does the work fill out the maintenance record. Check your warranty booklet for more information.

We recommend using Honda parts and fluids whenever you have maintenance done. These are manufactured to the same high-quality standards as the original components, so you can be confident of their performance and durability.

*CONTINUED*

U.S. Vehicles:

**Maintenance, replacement, or repair of emissions control devices and systems may be done by any automotive repair establishment or individual using parts that are “certified” to EPA standards.**

According to state and federal regulations, failure to perform maintenance on the items marked with # will not void your emissions warranties. However, all maintenance services should be performed in accordance with the intervals indicated by the information display.

## Owner’s Maintenance Checks

You should check the following items at the specified intervals. If you are unsure of how to perform any check, turn to the appropriate page listed.

- Engine oil level — Check every time you fill the fuel tank. See page [183](#) .
  - Engine coolant level — Check the radiator reserve tank every time you fill the fuel tank. See page [185](#) .
  - Automatic transmission — Check the fluid level monthly. See page [228](#) .
  - Brakes — Check the fluid level monthly. See page [230](#) .
  - Tires — Check the tire pressure monthly. Examine the tread for wear and foreign objects. See page [241](#) .
- Lights — Check the operation of the headlights, parking lights, taillights, high-mount brake light, and license plate lights monthly. See page [232](#) .

Symbol	Maintenance Main Items
A	<ul style="list-style-type: none"> <li>● Replace engine oil*</li> </ul>
B	<ul style="list-style-type: none"> <li>● Replace engine oil* and oil filter</li> <li>● Inspect front and rear brakes</li> <li>● Check parking brake adjustment</li> <li>● Visually inspect these items:                             <ul style="list-style-type: none"> <li>● Tie rod ends, steering gear box, and boots</li> <li>● Suspension components</li> <li>● Driveshaft boots</li> <li>● Brake hoses and line (including ABS)</li> <li>● All fluid levels and condition of fluids</li> <li>● Exhaust system<sup>#</sup></li> <li>● Fuel lines and connections<sup>#</sup></li> </ul> </li> </ul>

Symbol	Maintenance Sub Items
1	<ul style="list-style-type: none"> <li>● Rotate tires</li> </ul>
2	<ul style="list-style-type: none"> <li>● Replace air cleaner element If you drive primarily in dusty conditions, replace every 15,000 miles (24,000 km).</li> <li>● Replace dust and pollen filter If you drive primarily in urban areas that have high concentrations of soot in the air from industry and from diesel-powered vehicles, replace every 15,000 miles (24,000 km).</li> <li>● Inspect drive belt</li> </ul>
3	<ul style="list-style-type: none"> <li>● Replace transmission fluid</li> </ul>
4	<ul style="list-style-type: none"> <li>● Replace spark plugs</li> <li>● Inspect valve clearance</li> </ul>
5	<ul style="list-style-type: none"> <li>● Replace engine coolant</li> </ul>

\* : If the message "SERVICE" does not appear more than 12 months after the display is reset, change the engine oil every year.

# : See information on maintenance and emissions warranty in the first column on page 214.

NOTE: ● Independent of the maintenance minder indicator in the information display, replace the brake fluid every 3 years.  
 ● Inspect idle speed every 160,000 miles (256,000 km).  
 ● Adjust the valves during services A, B, 1, 2, or 3 only if they are noisy.

# Maintenance Record

You or the servicing dealer can record all completed maintenance here. When maintenance is performed, record the mileage, circle the coded item(s) completed, and write in any other non-coded items (such as brake fluid replacement) below the codes. Keep the receipts for all work done on your vehicle. Maintenance can also be recorded in your Honda service history booklet.

Mileage	Maintenance Performed	Signature
		Date
mi km	A B 1 2 3 4 5	
mi km	A B 1 2 3 4 5	
mi km	A B 1 2 3 4 5	
mi km	A B 1 2 3 4 5	
mi km	A B 1 2 3 4 5	
mi km	A B 1 2 3 4 5	
mi km	A B 1 2 3 4 5	
mi km	A B 1 2 3 4 5	

Mileage	Maintenance Performed	Signature
		Date
mi km	A B 1 2 3 4 5	
mi km	A B 1 2 3 4 5	
mi km	A B 1 2 3 4 5	
mi km	A B 1 2 3 4 5	
mi km	A B 1 2 3 4 5	
mi km	A B 1 2 3 4 5	
mi km	A B 1 2 3 4 5	
mi km	A B 1 2 3 4 5	

Mileage	Maintenance Performed	Signature
		Date
mi km	A B 1 2 3 4 5	
mi km	A B 1 2 3 4 5	
mi km	A B 1 2 3 4 5	
mi km	A B 1 2 3 4 5	
mi km	A B 1 2 3 4 5	
mi km	A B 1 2 3 4 5	
mi km	A B 1 2 3 4 5	

Mileage	Maintenance Performed	Signature
		Date
mi km	A B 1 2 3 4 5	
mi km	A B 1 2 3 4 5	
mi km	A B 1 2 3 4 5	
mi km	A B 1 2 3 4 5	
mi km	A B 1 2 3 4 5	
mi km	A B 1 2 3 4 5	
mi km	A B 1 2 3 4 5	





## Si model

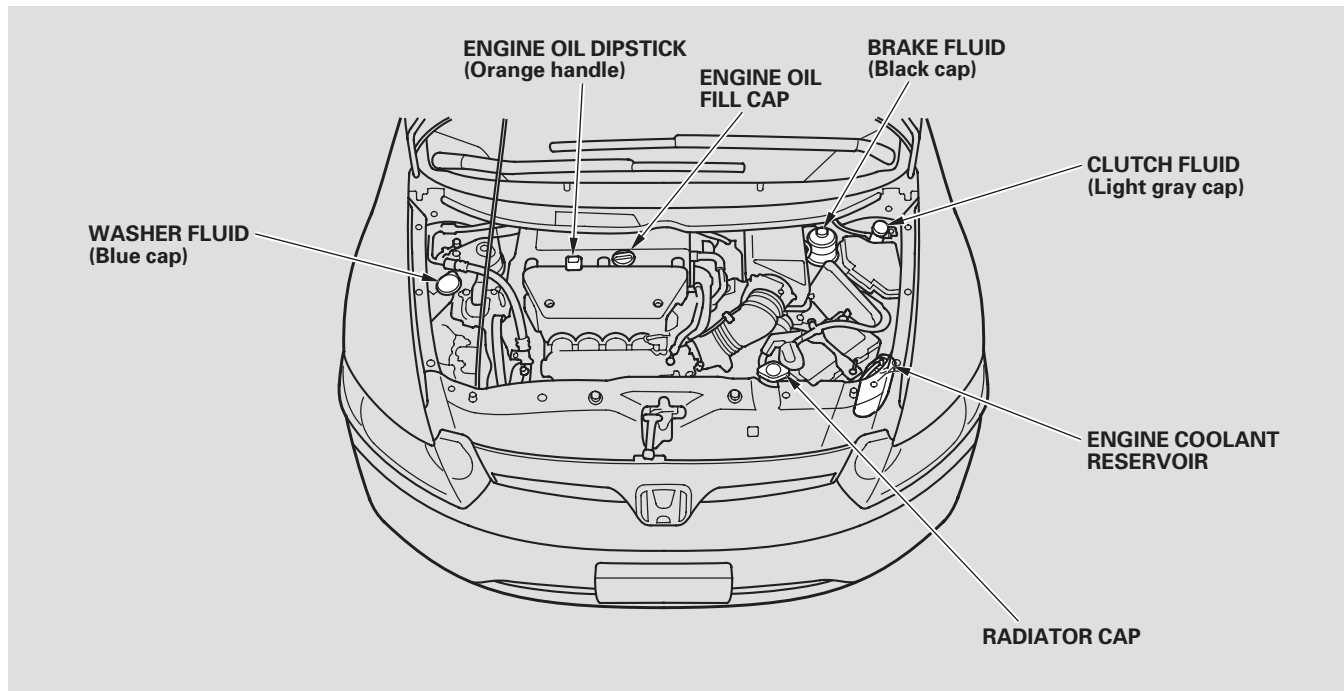

Make sure the API Certification Seal says “For Gasoline Engines.”

The oil viscosity or weight is provided on the container’s label.

## DX, Canadian DX-G, LX, and EX models:

Honda Motor Oil is the preferred 5W-20 lubricant for your vehicle. 5W-20 oil is formulated for year-round protection of your vehicle, to improve cold weather starting and fuel economy.

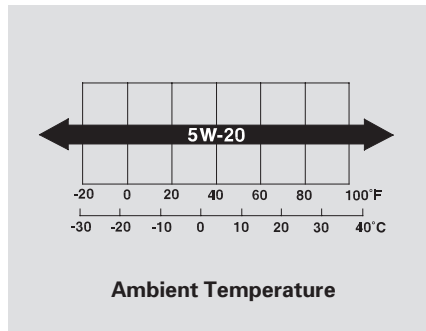

## Si model:

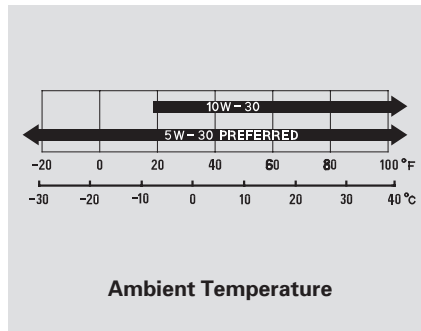

An oil with a viscosity of 5W-30 is preferred for improved fuel economy and year-round protection in your vehicle. You may use a 10W-30 oil if the temperature in your area never goes below 20° F (−7° C).

## Synthetic Oil

You may use a synthetic motor oil if it meets the same requirements given for a conventional motor oil: it displays the API Certification Seal, and it is the proper weight. You must follow the oil and filter change intervals shown on the information display.

## Engine Oil Additives

Your vehicle does not require any oil additives. Additives may adversely affect the engine or transmission performance and durability.

# Changing the Oil and Filter

Always change the oil and filter according to the maintenance messages shown on the information display. The oil and filter collect contaminants that can damage your engine if they are not removed regularly.

Changing the oil and filter requires special tools and access from underneath the vehicle. The vehicle should be raised on a service station-type hydraulic lift for this service. Unless you have the knowledge and proper equipment, you should have this maintenance done by a skilled mechanic.

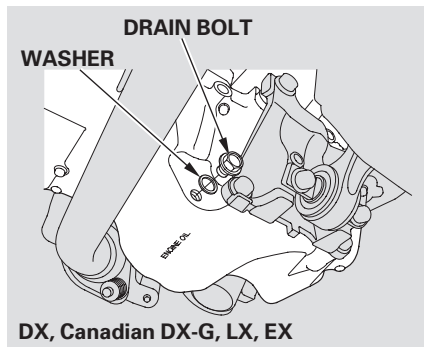

1. Run the engine until it reaches normal operating temperature, then shut it off.

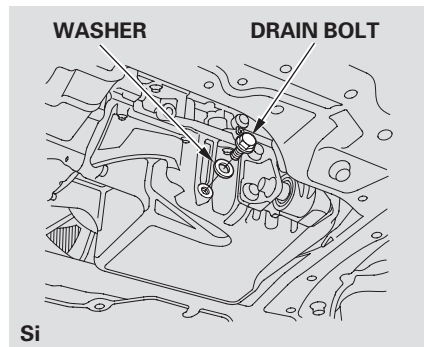

2. Open the hood, and remove the engine oil fill cap. Remove the oil drain bolt and washer from the bottom of the engine. Drain the oil into an appropriate container.

## OIL FILTER

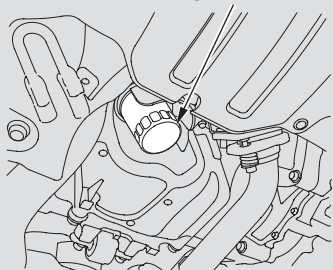

**DX, Canadian DX-G, LX, EX**

3. Remove the oil filter, and let the remaining oil drain. A special wrench (available from your dealer) is required.

Make sure the oil filter gasket is not stuck to the engine block. If it is, remove it before installing a new oil filter.

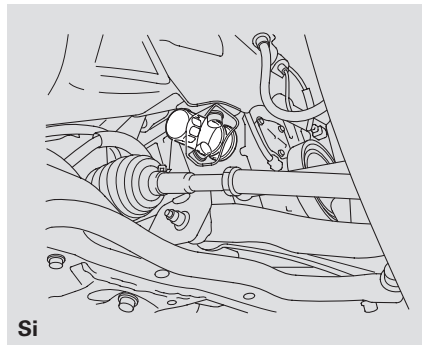

**Si**

4. Install a new oil filter according to the instructions that come with it.

Make sure to clean off any dirt and dust on the connecting surface of a new oil filter.

5. Put a new washer on the drain bolt, then reinstall the drain bolt. Tighten the drain bolt to:  
29 lbf·ft (39 N·m , 4.0 kgf·m)

6. Refill the engine with the recommended oil.  
Engine oil change capacity (including filter):

**DX, Canadian DX-G, LX, EX**  
3.9 US qt (3.7 ℓ)

**Si**  
4.6 US qt (4.4 ℓ)

7. Replace the engine oil fill cap. Start the engine. The oil pressure indicator should go out within 5 seconds. If it does not, turn off the engine, and check your work.
8. Let the engine run for several minutes, then check the drain bolt and oil filter for leaks.

*CONTINUED*

# Changing the Oil and Filter, Engine Coolant

- Turn off the engine, let it sit for several minutes, then check the oil level on the dipstick. If necessary, add more oil.

## NOTICE

*Improper disposal of engine oil can be harmful to the environment. If you change your own oil, please dispose of the used oil properly. Put it in a sealed container and take it to a recycling center. Do not discard it in a trash bin or dump it on the ground.*

## Adding Engine Coolant

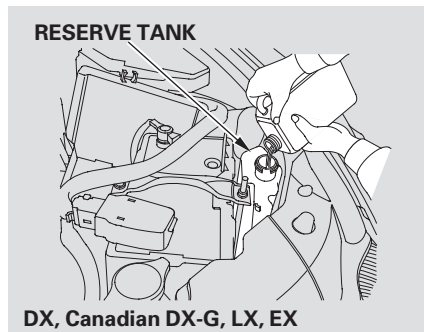

If the coolant level in the reserve tank is at or below the MIN line, add coolant to bring it up to the MAX line. Inspect the cooling system for leaks.

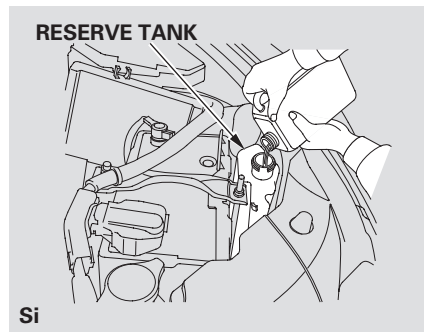

Always use Honda Long-life Antifreeze/Coolant Type 2. This coolant is pre-mixed with 50 percent antifreeze and 50 percent water. Never add straight antifreeze or plain water.

If Honda antifreeze/coolant is not available, you may use another major-brand non-silicate coolant as a temporary replacement. Make sure it is a high-quality coolant recommended for aluminum engines. Continued use of any non-Honda coolant can result in corrosion, causing the cooling system to malfunction or fail. Have the cooling system flushed and refilled with Honda antifreeze/coolant as soon as possible.

If the reserve tank is completely empty, you should also check the coolant level in the radiator.

## **⚠ WARNING**

Removing the radiator cap while the engine is hot can cause the coolant to spray out, seriously scalding you.

Always let the engine and radiator cool down before removing the radiator cap.

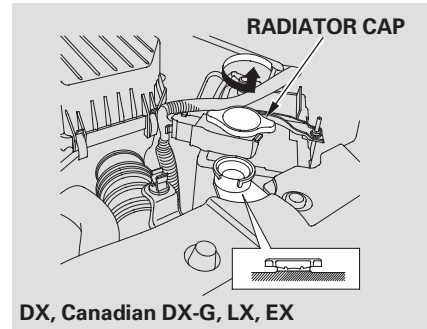

1. Make sure the engine and radiator are cool.
2. Relieve any pressure in the cooling system by turning the radiator cap counterclockwise, without pressing down.

*CONTINUED*

# Engine Coolant

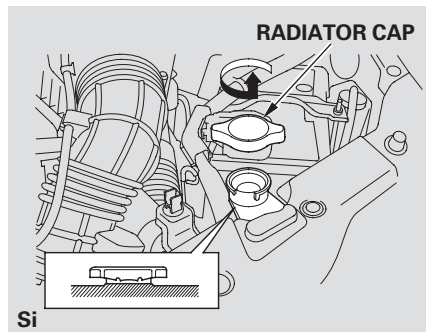

3. Remove the radiator cap by pushing down and turning counterclockwise.

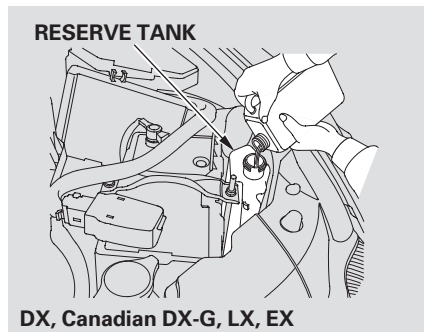

4. The coolant level should be up to the base of the filler neck. Add coolant if it is low.

Pour the coolant slowly and carefully so you do not spill any. Clean up any spill immediately; it could damage components in the engine compartment.

5. Put the radiator cap back on, and tighten it fully.

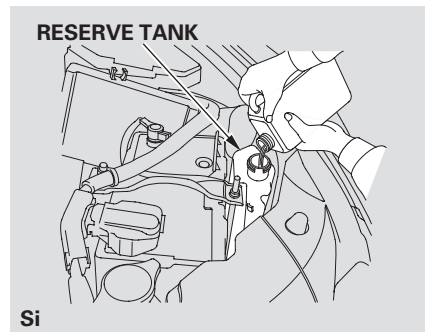

6. Pour coolant into the reserve tank. Fill it to halfway between the MAX and MIN marks. Put the cap back on the reserve tank.

Do not add any rust inhibitors or other additives to your vehicle's cooling system. They may not be compatible with the coolant or engine components.

Check the fluid level in the windshield washer reservoir at least monthly during normal use.

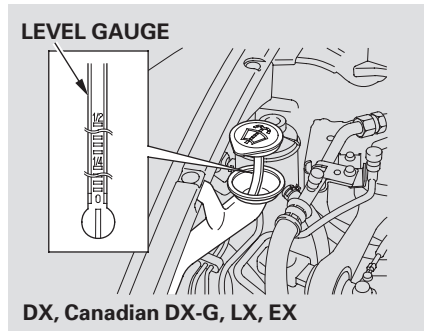

Check the fluid level by removing the cap and looking at the level gauge.

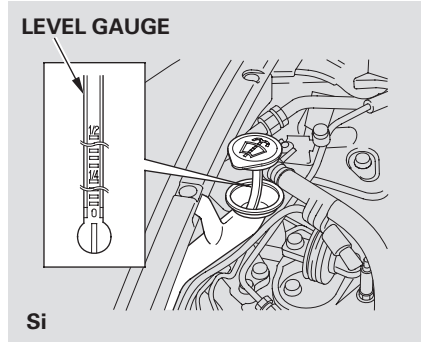

*On Canadian models:* The low washer level indicator comes on when the level is low (see page 61).

Fill the reservoir with a good-quality windshield washer fluid. This increases the cleaning capability and prevents freezing in cold weather.

When you refill the reservoir, clean the edges of the windshield wiper blades with windshield washer fluid on a clean cloth. This will help to condition the blade edges.

## NOTICE

*Do not use engine antifreeze or a vinegar/water solution in the windshield washer reservoir. Antifreeze can damage your vehicle's paint, while a vinegar/water solution can damage the windshield washer pump. Use only commercially-available windshield washer fluid.*



# Automatic Transmission Fluid

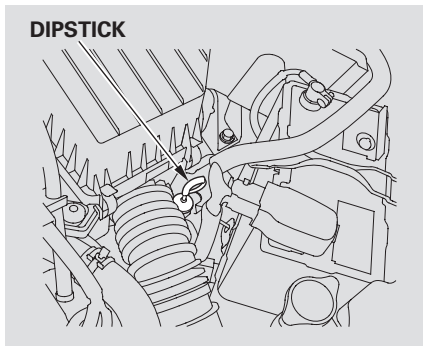

Check the fluid level with the engine at normal operating temperature.

1. Park the vehicle on level ground. Shut off the engine.
2. Remove the dipstick (yellow loop) from the transmission, and wipe it with a clean cloth.

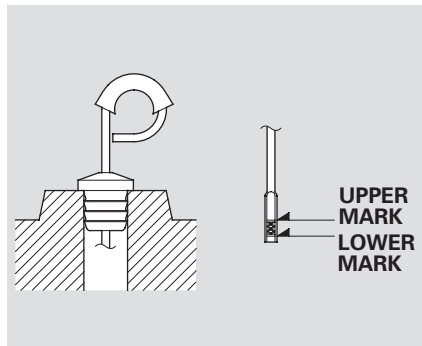

3. Insert the dipstick all the way into the transmission securely as shown in the illustration.
4. Remove the dipstick, and check the fluid level. It should be between the upper and lower marks.

5. If the level is below the lower mark, add fluid into the dipstick hole to bring it to the upper mark.

Pour the fluid slowly and carefully so you do not spill any. Clean up any spill immediately; it could damage components in the engine compartment.

Always use Honda ATF-Z1 (automatic transmission fluid). If it's not available, you may use a DEXRON® III automatic transmission fluid as a temporary replacement. However, continued use can affect the shift quality. Have the transmission flushed and refilled with Honda ATF-Z1 by your dealer as soon as it is convenient.

6. Insert the dipstick all the way back into the transmission securely as shown in the illustration.

The automatic transmission should be drained and refilled with new fluid when this service is indicated by a maintenance message on the information display.

If you are not sure how to add fluid, contact your dealer.

## Manual Transmission Fluid

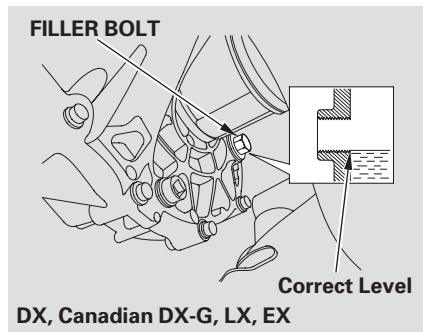

Check the fluid level with the transmission at normal operating temperature and the vehicle sitting on level ground. Remove the transmission filler bolt, and carefully feel inside the bolt hole with your finger. The fluid level should be up to the edge of the bolt hole. If it is not, add Honda Manual Transmission Fluid (MTF) until it starts to run out of the hole. Reinstall the filler bolt, and tighten it securely.

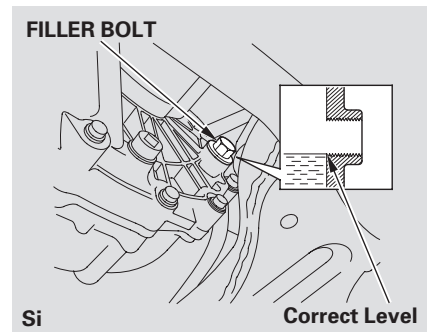

If Honda MTF is not available, you may use an SAE 10W-30 or 10W-40 viscosity motor oil with the API Certification seal that says "FOR GASOLINE ENGINES" as a temporary replacement. However, motor oil does not contain the proper additives, and continued use can cause stiffer shifting. Replace as soon as it is convenient.

CONTINUED

# Manual Transmission Fluid, Brake and Clutch Fluid

The manual transmission should be drained and refilled with new fluid when this service is indicated by a maintenance message on the information display.

If you are not sure how to check and add fluid, contact your dealer.

## Brake Fluid

Check the brake fluid level in the reservoirs monthly.

Replace the brake fluid according to the time recommendations in the maintenance minder schedule.

Always use Honda Heavy Duty Brake Fluid DOT 3. If it is not available, you should use only DOT 3 or DOT 4 fluid, from a sealed container, as a temporary replacement.

Using any non-Honda brake fluid can cause corrosion and decrease the life of the system. Have the brake system flushed and refilled with Honda Heavy Duty Brake Fluid DOT 3 as soon as possible.

Brake fluid marked DOT 5 is not compatible with your vehicle's braking system and can cause extensive damage.

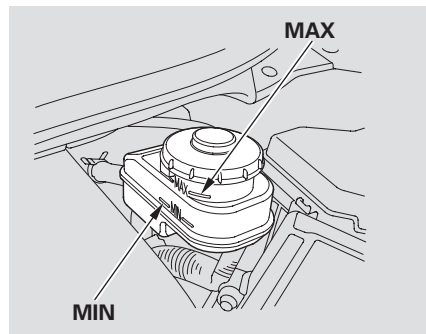

The fluid level should be between the MIN and MAX marks on the side of the reservoir. If the level is at or below the MIN mark, your brake system needs attention. Have the brake system inspected for leaks or worn brake pads.

## Clutch Fluid

*Manual Transmission only*

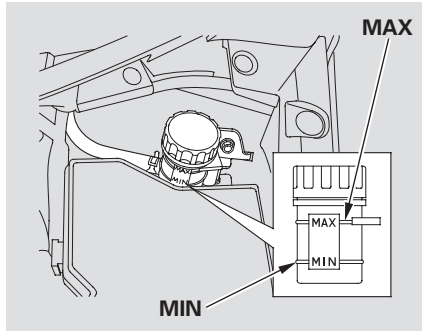

The fluid level should be between the MIN and MAX marks on the side of the reservoir. If it is not, add brake fluid to bring it up to that level. Use the same fluid specified for the brake system.

A low fluid level can indicate a leak in the clutch system. Have this system inspected as soon as possible.

## Power Steering Fluid

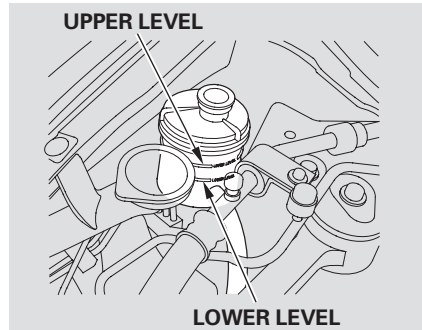

*All models except Si*

Check the level on the side of the reservoir when the engine is cold. The fluid should be between the UPPER LEVEL and LOWER LEVEL. If not add power steering fluid to the UPPER LEVEL mark.

Pour the fluid slowly and carefully so you do not spill any. Clean up any spill immediately; it could damage components in the engine

compartment.

Always use Honda Power Steering Fluid. You may use another power steering fluid as an emergency replacement, but have the power steering system flushed and refilled with Honda PSF as soon as possible.

A low power steering fluid level can indicate a leak in the system. Check the fluid level frequently, and have the system inspected as soon as possible.

### NOTICE

*Turning the steering wheel to full left or right lock and holding it there can damage the power steering pump.*

# Lights

## Headlight Aiming

The headlights were properly aimed when your vehicle was new. If you regularly carry heavy items in the trunk, readjustment may be required. Adjustment should be done by your dealer or other qualified mechanic.

### NOTICE

*Halogen headlight bulbs get very hot when lit. Oil, perspiration, or a scratch on the glass can cause the bulb to overheat and shatter.*

## Replacing a Headlight Bulb

Your vehicle has halogen headlight bulbs. When replacing a bulb, handle it by its base, and protect the glass from contact with your skin or hard objects. If you touch the glass, clean it with denatured alcohol and a clean cloth.

## High Beam Headlight

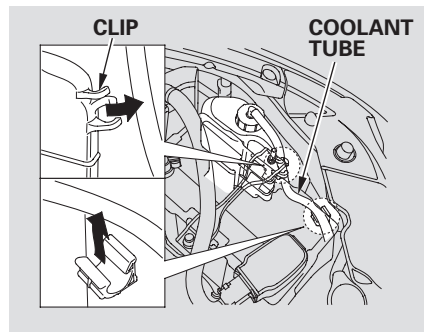

### 1. Open the hood.

To change a bulb on the driver's side, remove the coolant tube from the two clips, then remove the reserve tank from its holder by pulling it straight up.

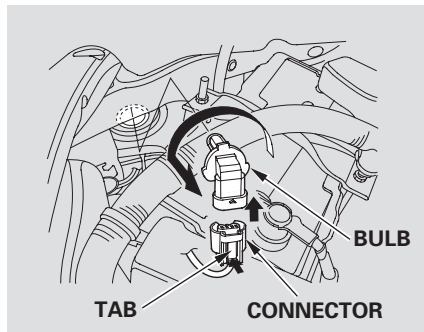
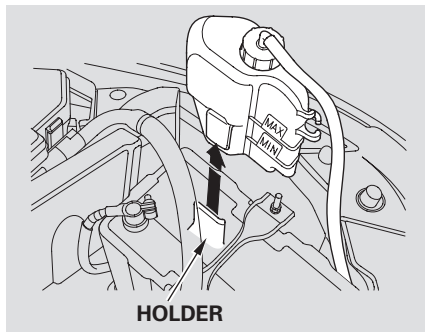

2. Remove the electrical connector from the bulb by pushing on the tab to unlock it, then slide the connector off the bulb.
3. Remove the bulb by turning it about one-quarter turn counterclockwise.

4. Insert the new bulb into the hole, and turn it one-quarter turn clockwise to lock it in place.
5. Push the electrical connector back onto the bulb. Make sure it is on all the way.
6. Turn on the headlights to test the new bulb.
7. (Driver's side)  
Put the tube back in the clips and install the reserve tank back in place, making sure its bottom tab is in the holder.

*CONTINUED*

## Low Beam Headlight

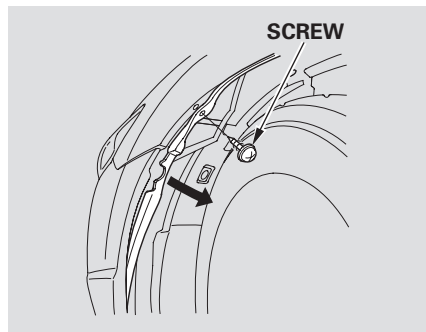

1. To change the driver's side bulb, start the engine, turn the steering wheel all the way to the right, and turn off the engine. To change the passenger's side bulb, turn the steering wheel to the left.

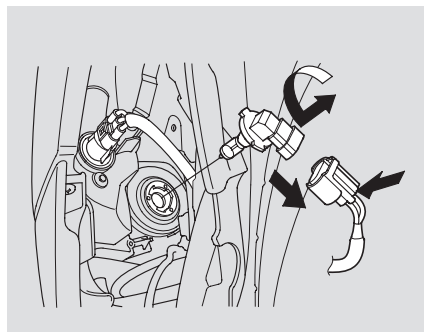

2. Use a Phillips head screwdriver to remove the screw from the inner fender, and pull the inner fender cover back.
3. Remove the electrical connector from the bulb by pushing on the tab to unlock it, then slide the connector off the bulb.
4. Remove the bulb from the headlight assembly by turning it one-quarter turn counterclockwise.
5. Insert the new bulb into the hole, and turn it one-quarter turn clockwise to lock it in place.
6. Push the electrical connector back onto the bulb. Make sure it is on all the way.
7. Turn on the headlights to test the new bulb.
8. Reinstall the inner fender cover. Then reinstall the screw and tighten it securely.

## Replacing the Front Side Marker/ Parking/Turn Signal Light Bulb

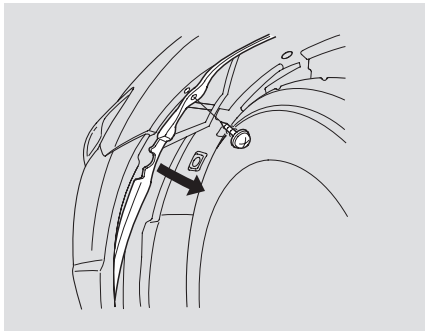

1. To change the driver's side bulb, start the engine, turn the steering wheel all the way to the right, and turn off the engine. To change the passenger's side bulb, turn the steering wheel to the left.

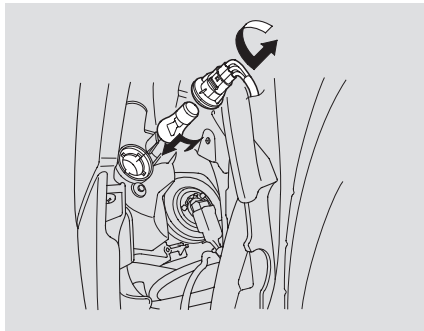

2. Use a Phillips head screwdriver to remove the screw from the inner fender, and pull the inner fender cover back.
3. Remove the socket from the headlight assembly by turning it one-quarter turn counterclockwise.

4. Remove the bulb from the socket by pushing the bulb in and turning it counterclockwise until it unlocks.
5. Install the new bulb in the socket. Turn it clockwise to lock it in place.
6. Insert the socket back into the headlight assembly. Turn it clockwise to lock it in place.
7. Turn on the lights to make sure the new bulb is working.
8. Reinstall the inner fender cover. Then reinstall the screw and tighten it securely.



## Replacing Rear Bulbs

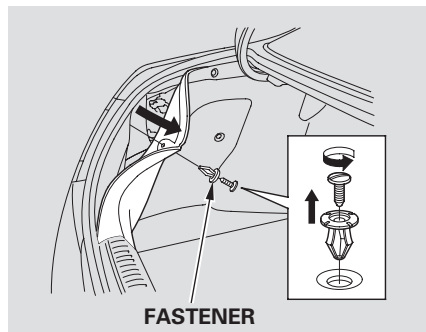

1. Open the trunk.

Remove the screw in the center of the fastener on the side of the trunk lining. Pull the lining back.

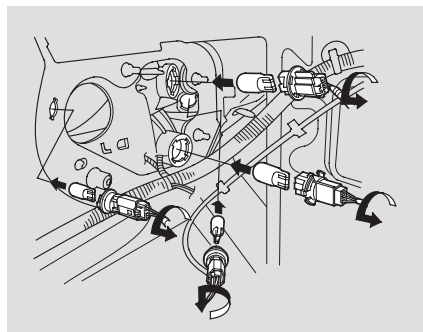

2. Determine which of the four bulbs is burned out: stop/taillight, back-up light, side marker light, or turn signal light.
3. Remove the socket by turning it one-quarter turn counterclockwise.

4. Pull the bulb straight out of its socket. Push the new bulb straight into the socket until it bottoms.
5. Reinstall the socket into the light assembly by turning it clockwise until it locks.
6. Turn on the lights to make sure the new bulb is working.
7. Reinstall the trunk lining. Make sure it is installed under the edge of the trunk seal.
8. Put the fastener into the hole on the side of the trunk lining. Reinstall the screw.



## Lights, Cleaning the Seat Belts

### Replacing a High-mount Brake Light Bulb

*On DX and LX models*

1. Open the trunk, then remove the holding clips from the cover, and remove the cover.
2. Remove the socket from the light assembly by turning it one-quarter turn counterclockwise.

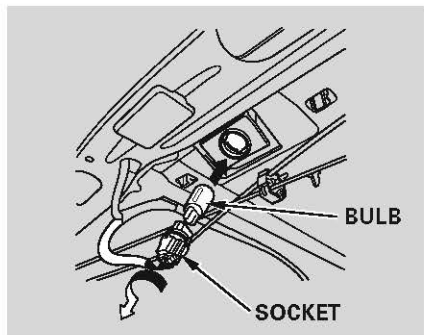

3. Pull the bulb straight out of its socket. Push the new bulb straight into the socket until it bottoms.
4. Reinstall the socket. Turn it clockwise until it locks. Make sure the new bulb is working.
5. Reinstall the cover, and tighten its holding clips securely.

### Cleaning the Seat Belts

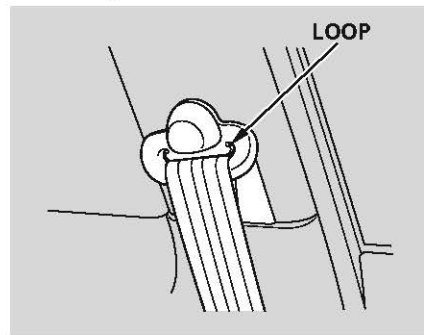

If your seat belts get dirty, use a soft brush with a mixture of mild soap and warm water to clean them. Do not use bleach, dye, or cleaning solvents. Let the belts air-dry before you use the vehicle.

CONTINUED

## Cleaning the Seat Belts, Floor Mats

---

Dirt build-up in the loops of the seat belt anchors can cause the belts to retract slowly. Wipe the insides of the loops with a clean cloth dampened in mild soap and warm water or isopropyl alcohol.

### Floor Mats

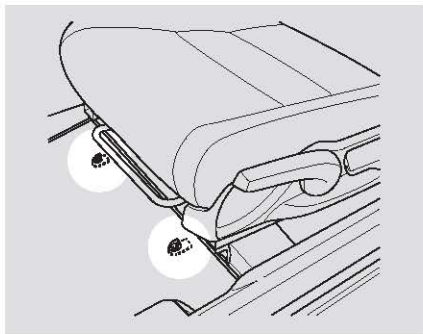

#### *If equipped*

The driver's floor mat that came with your vehicle hook over the floor mat anchors. This keeps the floor mat from sliding forward and possibly interfering with the pedals.

If you remove a floor mat, make sure to re-anchor it when you put it back in your vehicle.

If you use a non-Honda floor mat, make sure it fits properly and that it can be used with the floor mat anchors. Do not put additional floor mats on top of the anchored mat.

### Dust and Pollen Filter

*On models with A/C*

This filter removes the dust and pollen that is brought in from the outside through the heating and cooling system.

Have your dealer replace the filter when this service is indicated by a maintenance message on the information display. It should be replaced every 15,000 miles (24,000 km) if you drive primarily in urban areas that have high concentrations of soot in the air, or if the flow from the heating and cooling system becomes less than usual.

### Wiper Blades

Check the condition of the wiper blades at least every six months. Replace them if you find signs of cracking in the rubber, areas that are getting hard, or if they leave streaks and unwiped areas when used.

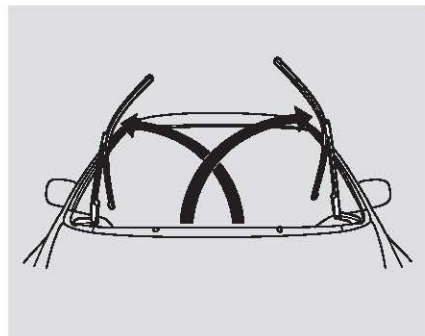

To replace a wiper blade:

1. Raise each wiper arm off the windshield, lifting the driver's side first, then the passenger's side.

### NOTICE

*Do not open the hood when the wiper arms are raised, or you will damage the hood and wiper arms.*

CONTINUED

## Wiper Blades

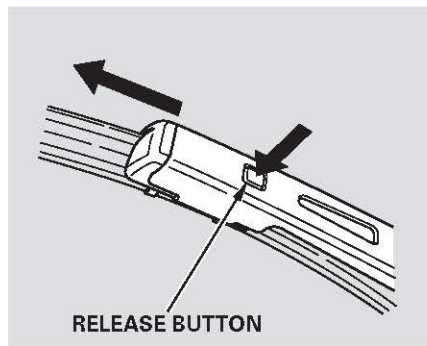

2. Disconnect the blade assembly from the wiper arm by pushing in the release button. Then slide the blade assembly out of the wiper arm.

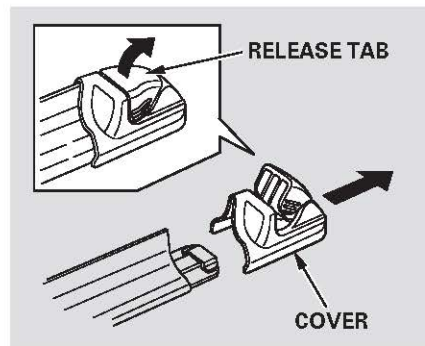

3. Pull up the cover release tab on the end of the blade assembly, then remove the cover.

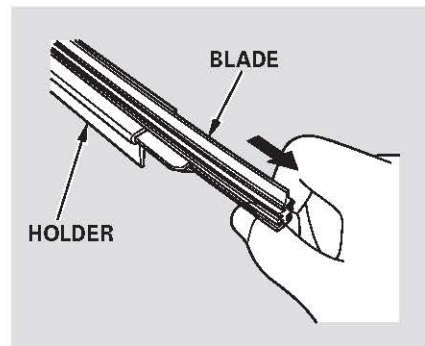

4. Slide the blade out of the holder.

# Tires

## Tire Maintenance

In addition to proper inflation, correct wheel alignment helps to decrease tire wear. If you find a tire is worn unevenly, have your dealer check the wheel alignment.

Have your dealer check the tires if you feel a consistent vibration while driving. A tire should always be rebalanced if it is removed from the wheel. When you have new tires installed, make sure they are balanced. This increases riding comfort and tire life. For best results, have the installer perform a dynamic balance.

### NOTICE

*For vehicles equipped with aluminum wheels:  
Improper wheel weights can damage your vehicle's wheels. Use only Honda wheel weights for balancing.*

## Tire Rotation

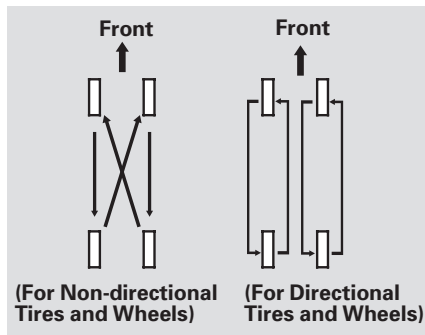

To help increase tire life and distribute wear more evenly, rotate the tires according to the maintenance messages displayed on the information display. Move the tires to the positions shown in the chart each time they are rotated. If you purchase directional tires, rotate each front-to-back.

## Tire Wear

*On Si model only*

The tires that came on your vehicle were designed and constructed to provide superior grip during acceleration, braking, and cornering.

As a trade-off, they will wear more rapidly than tires used on ordinary passenger vehicles. Because of the vehicle's weight distribution, and the fact that the front wheels are the driving wheels, you can expect them to wear more rapidly than the rear tires.

The mileage you can expect from your vehicle tires is the same as comparable mid-and rear-engine sports cars, and it will vary greatly with your driving habits.

If you drive moderately, the front tires could last more than 10,000 miles (16,000 km). However, the mileage will be substantially less if you tend to drive your vehicle at the upper limits of its capabilities.

You should carefully inspect your vehicle's tires for wear, damage, and proper inflation every 7,500 miles (12,000 km).

### Replacing Tires and Wheels

Replace your tires with radial tires of the same size, load range, speed rating, and maximum cold tire pressure rating (as shown on the tire's sidewall).

Mixing radial and bias-ply tires on your vehicle can reduce braking ability, traction, and steering accuracy. Using tires of a different size or construction can cause the ABS to work inconsistently.

It is best to replace all four tires at the same time. If that is not possible or necessary, replace the two front tires or two rear tires as a pair. Replacing just one tire can seriously affect your vehicle's handling.

The ABS works by comparing the speed of the wheels. When replacing tires, use the same size originally supplied with the vehicle. Tire size and construction can affect wheel speed and may cause the system to activate.

If you ever replace a wheel, make sure the new one matches the specifications of the original. Replacement wheels are available at your dealer.

### **WARNING**

Installing improper tires on your vehicle can affect handling and stability. This can cause a crash in which you can be seriously hurt or killed.

Always use the size and type of tires recommended in this owner's manual.

## Wheel and Tire Specifications

### Wheels:

DX and Canadian DX-G  
15 x 6 J

LX, EX  
16 x 6 1/2 J

Si  
17 x 7 J

### Tires:

DX and Canadian DX-G  
P195/65R15 89H

LX, EX  
P205/55R16 89H

Si  
P215/45R17 87V  
(all season tire)  
215/45R17 91W  
(summer tire)

See page [280](#) for information about DOT Tire Quality Grading, and page [282](#) for tire size and labeling information.

## Winter Driving

Tires marked “M + S” or “All Season” on the sidewall have an all-weather tread design suitable for most winter driving conditions.

For the best performance in snowy or icy conditions, you should install snow tires or tire chains. They may be required by local laws under certain conditions.

### *Snow Tires*

If you mount snow tires on your vehicle, make sure they are radial tires of the same size and load range as original tires. Mount snow tires on all four wheels. The traction provided by snow tires on dry roads may be lower than your original tires. Check with the tire dealer for maximum speed recommendations.



### ***Tire Chains***

*DX, Canadian DX-G, LX and EX models*

Because your vehicle has limited tire clearance, mount only SAE Class “S” cable-type traction devices, with rubber chain tensioners, on the front tires. Use traction devices only when required by driving conditions or local laws. Make sure they are the correct size for your tires. Metal link-type “chains” should not be used.

When installing cables, follow the manufacturer’s instructions, and mount them as tight as you can. Make sure they are not contacting the brake lines or suspension. Drive slowly with them installed. If you hear them coming into contact with the body or chassis, stop and investigate. Remove them as soon as you begin driving on cleared roads.

### ***Si model***

Because your vehicle has limited tire clearance, Honda strongly recommends using the chains listed below, made by Security Chain Company (SCC).

CH2311T

### **NOTICE**

*Traction devices that are the wrong size or improperly installed can damage your vehicle’s brake lines, suspension, body, and wheels. Stop driving if they are hitting any part of the vehicle.*

## Checking the Battery

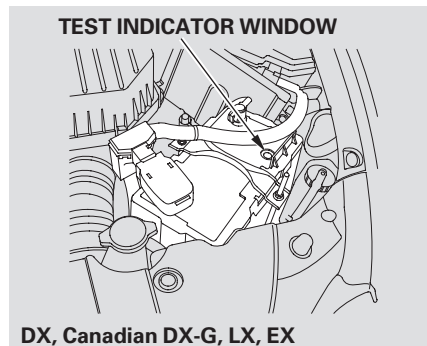

Check the condition of the battery monthly by looking at the test indicator window. The label on the battery explains the test indicator's colors.

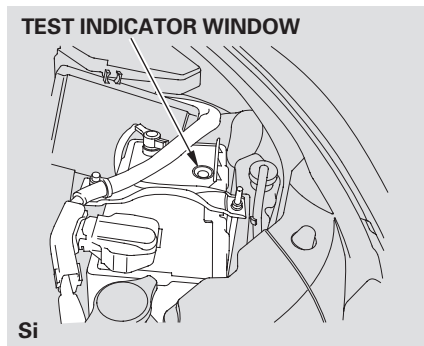

Check the terminals for corrosion (a white or yellowish powder). To remove it, cover the terminals with a solution of baking soda and water. It will bubble up and turn brown. When this stops, wash it off with plain water. Dry off the battery with a cloth or paper towel. Coat the terminals with grease to help prevent further corrosion.

If additional battery maintenance is needed, see your dealer or a qualified technician.

**WARNING:** Battery posts, terminals, and related accessories contain lead and lead compounds. **Wash your hands after handling.**

If you need to connect the battery to a charger, disconnect both cables to prevent damaging your vehicle's electrical system. Always disconnect the negative (–) cable first, and reconnect it last.

## **WARNING**

The battery gives off explosive hydrogen gas during normal operation.

A spark or flame can cause the battery to explode with enough force to kill or seriously hurt you.

Wear protective clothing and a face shield, or have a skilled mechanic do the battery maintenance.

If your vehicle's battery is disconnected or goes dead, the audio system will disable itself. The next time you turn on the radio you will see "ENTER CODE" in the frequency display. Use the preset buttons to enter the code (see page 172).

*On vehicles with navigation system*  
The navigation system will also disable itself. The next time you turn on the ignition switch, the system will require you to enter a PIN before it can be used. Refer to the navigation system manual.

# Vehicle Storage

---

If you need to park your vehicle for an extended period (more than 1 month), there are several things you should do to prepare it for storage. Proper preparation helps prevent deterioration and makes it easier to get your vehicle back on the road. If possible, store your vehicle indoors.

- Fill the fuel tank.
- Change the engine oil and filter.
- Wash and dry the exterior completely.
- Clean the interior. Make sure the carpeting, floor mats, etc., are completely dry.
- Leave the parking brake off. Put the transmission in reverse (manual) or Park (automatic).

- Block the rear wheels.
- If the vehicle is to be stored for a longer period, it should be supported on jackstands so the tires are off the ground.
- Leave one window open slightly (if the vehicle is being stored indoors).
- Disconnect the battery.
- Support the front wiper blade arms with a folded towel or rag so they do not touch the windshield.
- To minimize sticking, apply a silicone spray lubricant to all door and trunk seals. Also, apply a vehicle body wax to the painted surfaces that mate with the door and trunk seals.

- Cover the vehicle with a “breathable” cover, one made from a porous material such as cotton. Non-porous materials, such as plastic sheeting, trap moisture, which can damage the paint.
- If possible, periodically run the engine until it reaches full operating temperature (the cooling fans cycle on and off twice). Preferably, do this once a month.

This section covers the more common problems that motorists experience with their vehicles. It gives you information about how to safely evaluate the problem and what to do to correct it. If the problem has stranded you on the side of the road, you may be able to get going again. If not, you will also find instructions on getting your vehicle towed.

Compact Spare Tire.....	252
Changing a Flat Tire .....	253
If the Engine Won't Start.....	257
Jump Starting .....	259
If the Engine Overheats .....	261
Low Oil Pressure Indicator .....	263
Charging System Indicator.....	263
Malfunction Indicator Lamp .....	264
Brake System Indicator .....	265
Fuses .....	266
Fuse Locations.....	270
Emergency Towing.....	272

## Compact Spare Tire

Use the compact spare tire as a temporary replacement only. Get your regular tire repaired or replaced, and put it back on your vehicle as soon as you can.

Check the inflation pressure of the compact spare tire every time you check the other tires. It should be inflated to:

60 psi (420 kPa , 4.2 kgf/cm<sup>2</sup>)

Follow these precautions:

- Never exceed 50 mph (80 km/h).
- This tire gives a harsher ride and less traction on some road surfaces. Use greater caution while driving.

- Do not mount tire chains on the compact spare tire.
- Do not use your compact spare tire on another vehicle unless it is the same make and model.

### *On Si model*

- Do not use a compact spare tire mounted on a front wheel; it will damage the limited slip differential (see page [253](#) ).

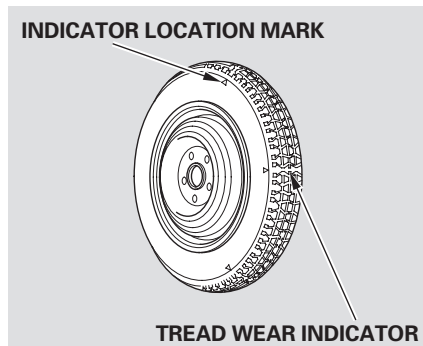

Replace the tire when you can see the tread wear indicator bars. The replacement should be the same size and design tire, mounted on the same wheel. The spare tire is not designed to be mounted on a regular wheel, and the spare wheel is not designed for mounting a regular tire.

If you have a flat tire while driving, stop in a safe place to change it. Drive slowly along the shoulder until you get to an exit or an area that is far away from the traffic lanes.

The compact spare tire is smaller than a standard tire, and it will affect the vehicle's handling. Drive cautiously when the spare is mounted on your vehicle.

*On Si model only*

The size difference may also cause damage to the differential, so do not mount the compact spare on the front. If either front tire goes flat, remove the rear tire on that same side, mount the compact spare tire on the rear, then mount the rear tire on the front.

## ⚠ WARNING

The vehicle can easily roll off the jack, seriously injuring anyone underneath.

Follow the directions for changing a tire exactly, and never get under the vehicle when it is supported only by the jack.

1. Park the vehicle on firm, level, and non-slippery ground. Put the transmission in Park (automatic) or reverse (manual). Apply the parking brake.
2. Turn on the hazard warning lights, and turn the ignition switch to the LOCK (0) position. Have all passengers get out of the vehicle while you change the tire.

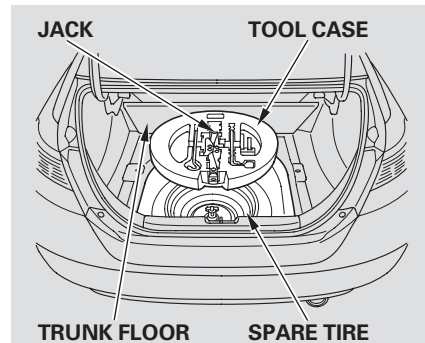

3. Open the trunk. Raise the trunk floor by lifting up on the back edge.
4. Take the tool kit case out of the trunk.
5. Unscrew the wing bolt, and take the spare tire out of its well.

CONTINUED

# Changing a Flat Tire

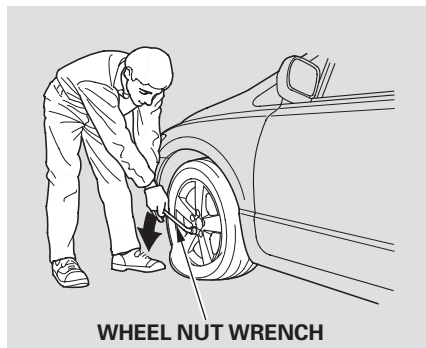

6. Loosen each wheel nut 1/2 turn with the wheel nut wrench.

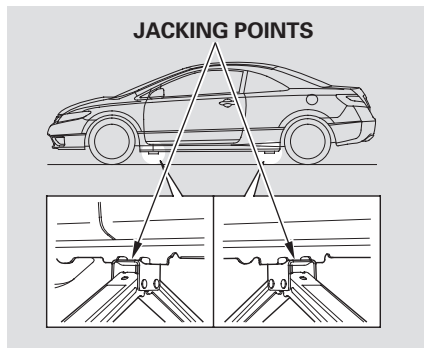

7. Place the jack under the jacking point nearest the tire you need to change. Turn the end bracket clockwise until the top of the jack contacts the jacking point. Make sure the jacking point tab is resting in the jack notch.

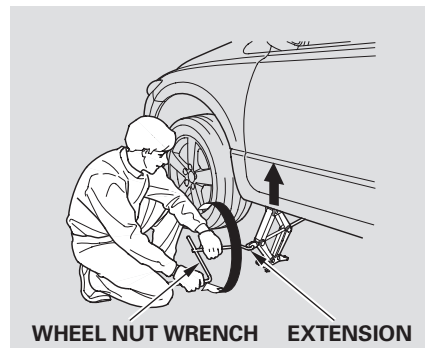

8. Use the extension and the wheel nut wrench as shown to raise the vehicle until the flat tire is off the ground.
9. Remove the wheel nuts, then remove the flat tire. Handle the wheel nuts carefully; they may be hot from driving. Place the flat tire on the ground with the outside surface facing up.



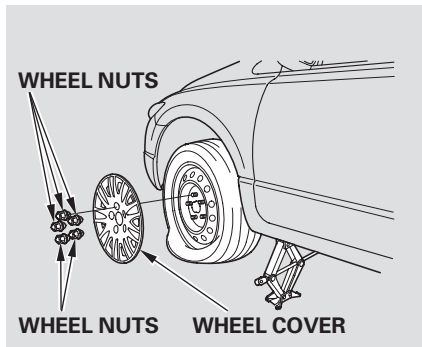

*DX, Canadian DX-G, and LX models*  
Do not attempt to forcibly pry the wheel cover off with a screwdriver or other tool. The wheel cover cannot be removed without first removing the wheel nuts.

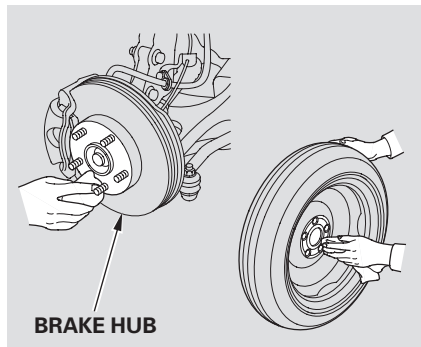

10. Before mounting the spare tire, wipe any dirt off the mounting surface of the wheel and hub with a clean cloth. Wipe the hub carefully; it may be hot from driving.



11. Put on the spare tire. Put the wheel nuts back on finger-tight, then tighten them in a crisscross pattern with the wheel nut wrench until the wheel is firmly against the hub. Do not try to tighten them fully.

12. Lower the vehicle to the ground, and remove the jack.

CONTINUED

# Changing a Flat Tire

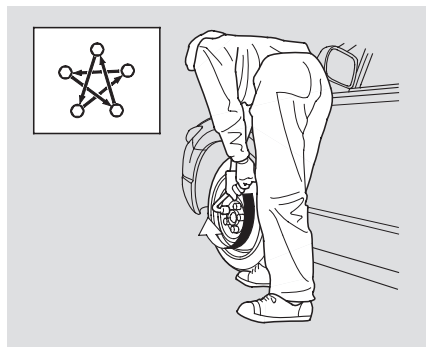

13. Tighten the wheel nuts securely in the same crisscross pattern. Have the wheel nut torque checked at the nearest automotive service facility.

Tighten the wheel nuts to:  
80 lbf·ft (108 N·m , 11 kgf·m)

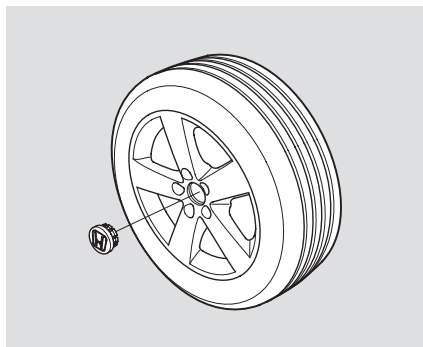

14. *On EX and Si models in the U.S., and LX, EX, and Si models in Canada* Remove the center cap from the flat tire.

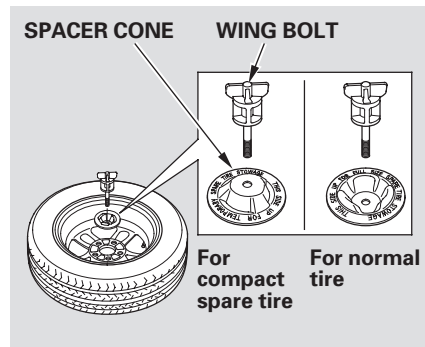

15. Place the flat tire face down in the spare tire well.
16. Remove the spacer cone from the wing bolt, turn it over, and put it back on the bolt.
17. Secure the flat tire by screwing the wing bolt back into its hole.

18. Store the jack and tools in the tool kit case. Place the tool kit case in the center of the flat tire.

## **WARNING**

Loose items can fly around the interior in a crash and could seriously injure the occupants.

Store the wheel, jack, and tools securely before driving.

19. Store the wheel cover or center cap in the trunk. Make sure it does not get scratched or damaged.
20. Lower the trunk floor, then close the trunk lid.

## **If the Engine Won't Start**

Diagnosing why the engine won't start falls into two areas, depending on what you hear when you turn the ignition switch to the START (III) position:

- You hear nothing, or almost nothing. The engine's starter motor does not operate at all, or operates very slowly.
- You can hear the starter motor operating normally, or the starter motor sounds like it is spinning faster than normal, but the engine does not start up and run.

## **Nothing Happens or the Starter Motor Operates Very Slowly**

When you turn the ignition switch to the START (III) position, you do not hear the normal noise of the engine trying to start. You may hear a clicking sound or series of clicks, or nothing at all.

Check these things:

- Check the transmission interlock. If you have a manual transmission, the clutch pedal must be pushed all the way to the floor or the starter will not operate. With an automatic transmission, it must be in Park or neutral.
- Turn the ignition switch to the ON (II) position. Turn on the headlights, and check their brightness. If the headlights are very dim or do not come on at all, the battery is discharged. See **Jump Starting** on page [259](#).

*CONTINUED*

## If the Engine Won't Start

---

- Turn the ignition switch to the START (III) position. If the headlights do not dim, check the condition of the fuses. If the fuses are OK, there is probably something wrong with the electrical circuit for the ignition switch or starter motor. You will need a qualified technician to determine the problem (see **Emergency Towing** on page 272 ).

If the headlights dim noticeably or go out when you try to start the engine, either the battery is discharged or the connections are corroded. Check the condition of the battery and terminal connections (see page 248 ). You can then try jump starting the vehicle from a booster battery (see page 259 ).

### The Starter Operates Normally

In this case, the starter motor's speed sounds normal, or even faster than normal, when you turn the ignition switch to the START (III) position, but the engine does not run.

- Are you using a properly coded key? An improperly coded key will cause the immobilizer system indicator in the instrument panel to blink rapidly (see page 75 ).
- Are you using the proper starting procedure? Refer to **Starting the Engine** on page 194 .

- Do you have fuel? Check the fuel gauge; the low fuel indicator may not be working.
- There may be an electrical problem, such as no power to the fuel pump. Check all the fuses (see page 266 ).

If you find nothing wrong, you will need a qualified technician to find the problem. See **Emergency Towing** on page 272 .

Although this seems like a simple procedure, you should take several precautions.

## **⚠ WARNING**

A battery can explode if you do not follow the correct procedure, seriously injuring anyone nearby.

Keep all sparks, open flames, and smoking materials away from the battery.

You cannot start your vehicle with an automatic transmission by pushing or pulling it.

To jump start your vehicle:

1. Open the hood, and check the physical condition of the battery. In very cold weather, check the condition of the electrolyte. If it seems slushy or frozen, do not try jump starting until it thaws.

## **NOTICE**

*If a battery sits in extreme cold, the electrolyte inside can freeze. Attempting to jump start with a frozen battery can cause it to rupture.*

2. Turn off all the electrical accessories: heater, A/C, audio system, lights, etc. Put the transmission in neutral (M/T) or Park (A/T), and set the parking brake.

DX, Canadian DX-G, LX, EX

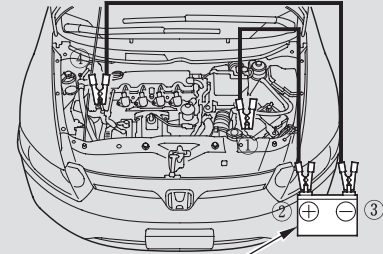

**BOOSTER BATTERY**

The numbers in the illustrations show you the order to connect the jumper cables.

CONTINUED

# Jump Starting

Si

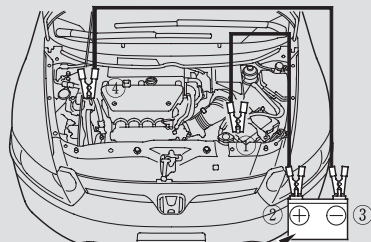

**BOOSTER BATTERY**

3. Connect one jumper cable to the positive (+) terminal on your battery. Connect the other end to the positive (+) terminal on the booster battery.

DX, Canadian DX-G, LX, EX

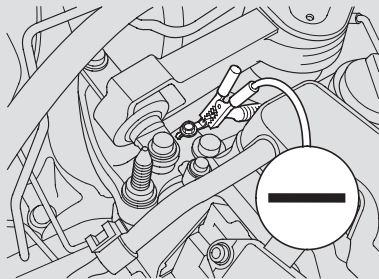

4. Connect the second jumper cable to the negative (-) terminal on the booster battery. Connect the other end to the grounding strap as shown. Do not connect this jumper cable to any other part of the engine.

5. If the booster battery is in another vehicle, have an assistant start that vehicle and run it at a fast idle.

Si

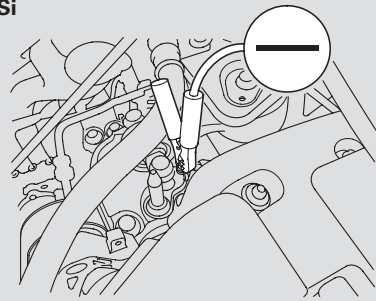

6. Start the vehicle. If the starter motor still operates slowly, check that the jumper cables have good metal-to-metal contact.

7. Once your vehicle is running, disconnect the negative cable from your vehicle, then from the booster battery. Disconnect the positive cable from your vehicle, then from the booster battery.

Keep the ends of the jumper cables away from each other and any metal on the vehicle until everything is disconnected. Otherwise, you may cause an electrical short.

## If the Engine Overheats

The pointer of the vehicle's temperature gauge should stay in the midrange. If it climbs to the red mark, you should determine the reason (hot day, driving up a steep hill, etc.).

If the vehicle overheats, you should take immediate action. The only indication may be the temperature gauge climbing to or above the red mark. Or you may see steam or spray coming from under the hood.

## NOTICE

*Driving with the temperature gauge pointer at the red mark can cause serious damage to the engine.*

## ⚠ WARNING

Steam and spray from an overheated engine can seriously scald you.

Do not open the hood if steam is coming out.

1. Safely pull to the side of the road. Put the transmission in neutral (M/T) or Park (A/T), and set the parking brake. Turn off all accessories, and turn on the hazard warning indicators.
2. If you see steam and/or spray coming from under the hood, turn off the engine. Wait until you see no more signs of steam or spray, then open the hood.

CONTINUED

## If the Engine Overheats

---

- If you do not see steam or spray, leave the engine running, and watch the temperature gauge. If the high heat is due to overloading, the engine should start to cool down almost immediately. If it does, wait until the temperature gauge comes down to the midpoint, then continue driving.
  - If the temperature gauge stays at the red mark, turn off the engine.
  - Look for any obvious coolant leaks, such as a split radiator hose. Everything is still extremely hot, so use caution. If you find a leak, it must be repaired before you continue driving (see **Emergency Towing** on page [272](#) ).
  - If you don't find an obvious leak, check the coolant level in the radiator reserve tank (see page [185](#) ). Add coolant if the level is below the MIN mark.
  - If there was no coolant in the reserve tank, you may need to add coolant to the radiator. Let the engine cool down until the reading reaches the middle of the temperature gauge or lower before checking the radiator.
- ⚠ WARNING**

Removing the radiator cap while the engine is hot can cause the coolant to spray out, seriously scalding you.

Always let the engine and radiator cool down before removing the radiator cap.
- Using gloves or a large heavy cloth, turn the radiator cap counterclockwise, without pushing down, to the first stop. After the pressure releases, push down on the cap, and turn it until it comes off.
  - Start the engine, and set the temperature control dial to maximum heat. Add coolant to the radiator up to the base of the filler neck. If you do not have the proper coolant mixture available, you can add plain water. Remember to have the cooling system drained and refilled with the proper mixture as soon as you can.
  - Put the radiator cap back on tightly. Run the engine, and watch the temperature gauge. If it goes back to the red mark, the engine needs repair (see **Emergency Towing** on page [272](#) ).
  - If the temperature stays normal, check the coolant level in the radiator reserve tank. If it has gone down, add coolant to the MAX mark. Put the cap back on tightly.



## Low Oil Pressure Indicator



This indicator should never come on when the engine is running. If it starts flashing or stays on, the oil pressure has dropped very low or lost pressure. Serious engine damage is possible, and you should take immediate action.

### NOTICE

*Running the engine with low oil pressure can cause serious mechanical damage almost immediately. Turn off the engine as soon as you can safely get the vehicle stopped.*

1. Safely pull off the road, and shut off the engine. Turn on the hazard warning indicators.
2. Let the vehicle sit for a minute. Open the hood, and check the oil level (see page [183](#)). An engine very low on oil can lose pressure during cornering and other driving maneuvers.
3. If necessary, add oil to bring the level back to the full mark on the dipstick (see page [220](#)).
4. Start the engine, and watch the oil pressure indicator. If it does not go out within 10 seconds, turn off the engine. There is a mechanical problem that needs to be repaired before you can continue driving (see **Emergency Towing** on page [272](#)).

## Charging System Indicator



If the charging system indicator comes on brightly when the engine is running, the battery is not being charged.

Immediately turn off all electrical accessories. Try not to use other electrically operated controls such as the power windows. Keep the engine running; starting the engine will discharge the battery rapidly.

Go to a service station or garage where you can get technical assistance.

# Malfunction Indicator Lamp



If the indicator comes on while driving, it means one of the engine's emissions control systems may have a problem. Even though you may feel no difference in your vehicle's performance, it can reduce your fuel economy and cause increased emissions. Continued operation may cause serious damage.

If you have recently refueled your vehicle, the indicator coming on could be due to a loose or missing fuel fill cap. You will also see a "CHECK FUEL CAP" message on the information display. Tighten the cap until it clicks at least once (see page 181). Tightening the cap will not turn the indicator off immediately; it can take several days of normal driving.

If the indicator comes on repeatedly, even though it may turn off as you continue driving, have the vehicle checked by your dealer as soon as possible.

## NOTICE

*If you keep driving with the malfunction indicator lamp on, you can damage your vehicle's emissions controls and engine. Those repairs may not be covered by your vehicle's warranties.*

This indicator may also come on with the "D" indicator.

## Readiness Codes

Your vehicle has certain "readiness codes" that are part of the on-board diagnostics for the emissions systems. In some states, part of the emissions testing is to make sure these codes are set. If they are not set, the test cannot be completed.

If your vehicle battery has been disconnected or gone dead, these codes are erased. It can take several days of driving under various conditions to set the codes again.

To check if they are set, turn the ignition switch to the ON (II) position, without starting the engine. The malfunction indicator lamp will come on for 20 seconds. If it then goes off, the readiness codes are set. If it blinks five times, the readiness codes are not set. If possible, do not take your vehicle for a state emissions test until the readiness codes are set. Refer to **State Emissions Testing** for more information (see page 286).

U.S.

**BRAKE**

Canada



The brake system indicator normally comes on when you turn the ignition switch to the ON (II) position and as a reminder to check the parking brake. It will stay on if you do not fully release the parking brake.

If the brake system indicator comes on while driving, the brake fluid level is probably low. Press lightly on the brake pedal to see if it feels normal. If it does, check the brake fluid level the next time you stop at a service station (see page [230](#)).

If the fluid level is low, take your vehicle to a dealer, and have the brake system inspected for leaks or worn brake pads.

However, if the brake pedal does not feel normal, you should take immediate action. A problem in one part of the system's dual circuit design will still give you braking at two wheels. You will feel the brake pedal go down much farther before the vehicle begins to slow down, and you will have to press harder on the pedal.

Slow down by shifting to a lower gear, and pull to the side of the road when it is safe. Because of the long distance needed to stop, it is hazardous to drive the vehicle. You should have it towed and repaired as soon as possible (see **Emergency Towing** on page [272](#)).

If you must drive the vehicle a short distance in this condition, drive slowly and carefully.

If the ABS indicator comes on with the brake system indicator, have your vehicle inspected by your dealer immediately.

# Fuses

## INTERIOR

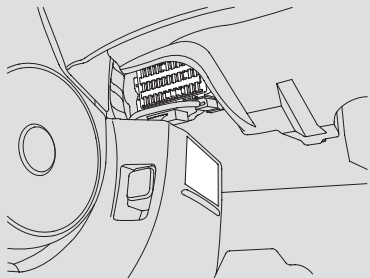

The vehicle's fuses are contained in two fuse boxes.

The interior fuse box is on the driver's lower left side.

## UNDER-HOOD

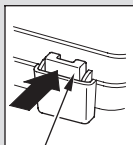

TAB

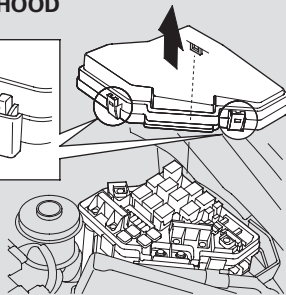

The under-hood fuse box is in the engine compartment on the driver's side, next to the brake fluid reservoir. To open it, push the tabs as shown.

## Checking and Replacing Fuses

If something electrical in your vehicle stops working, check for a blown fuse first. Determine from the chart on pages [270](#) and [271](#), or the diagram on the fuse box lid, which fuse or fuses control that device. Check those fuses first, but check all the fuses before deciding that a blown fuse is the cause. Replace any blown fuses, and check if the device works.

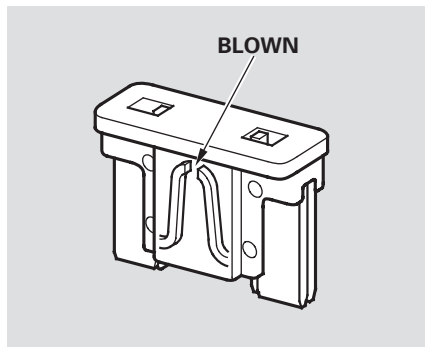

5. Look for a blown wire inside the fuse. If it is blown, replace it with one of the spare fuses of the same rating or lower.

If you cannot drive the vehicle without fixing the problem, and you do not have a spare fuse, take a fuse of the same rating or a lower rating from one of the other circuits. Make sure you can do without that circuit temporarily (such as the accessory power socket or radio).

If you replace the blown fuse with a spare fuse that has a lower rating, it might blow out again. This does not indicate anything wrong. Replace the fuse with one of the correct rating as soon as you can.

## NOTICE

*Replacing a fuse with one that has a higher rating greatly increases the chances of damaging the electrical system. If you do not have a replacement fuse with the proper rating for the circuit, install one with a lower rating.*

6. If the replacement fuse of the same rating blows in a short time, there is probably a serious electrical problem in your vehicle. Leave the blown fuse in that circuit and have your vehicle checked by a qualified mechanic.

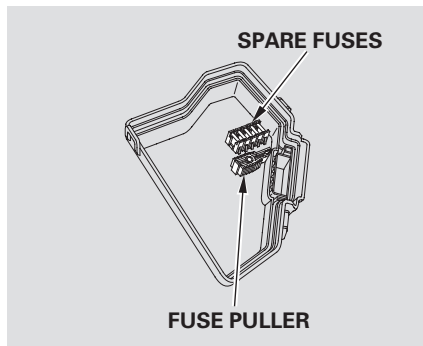

3. Your vehicle has spare fuses on the back of the under-hood fuse box cover.

*All models except DX*

If the driver's power window fuse is removed, the AUTO function of the driver's window will be disabled. You should reset the AUTO feature, (see page [97](#) ).

If the radio fuse is removed, the audio system will disable itself. The next time you turn on the radio you will see "ENTER CODE" in the frequency display. Use the preset buttons to enter the digit code (see page [172](#) ).

When the audio system is disabled, the clock setting in the audio system will be canceled. You will need to reset the clock (see page [173](#) ).

# Fuse Locations

## UNDER-HOOD FUSE BOX

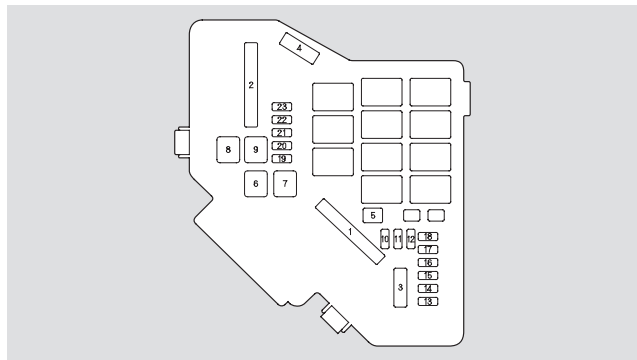

No.	Amps.	Circuits Protected
1	100 A	Main Fuse
	70 A	EPS*
2	80 A	Option
	50 A	Ignition Switch Main
3	30 A	ABS Motor
	30 A	ABS F/S
4	50 A	Headlight Main
	40 A	Power Window Main
5	—	Not Used

No.	Amps.	Circuits Protected
6	20 A	Fan Moter
7	30 A	Main Fan Moter (A/T)
	20 A	Main Fan Moter (M/T)
8	40 A	Rear Defroster
9	40 A	Blower
10	10 A	Hazard
11	15 A	FI
12	15 A	Stop, Horn
13	—	Not Used
14	—	Not Used
15	7.5 A	Oil Level Sensor
16	—	Not Used
17	—	Not Used
18	15 A	Ignition Coil
19	15 A	FI Main
20	7.5 A	MG Clutch
21	15 A	DBW
22	7.5 A	Interior Light
23	10 A	Back Up

\* : Si model

## INTERIOR FUSE BOX

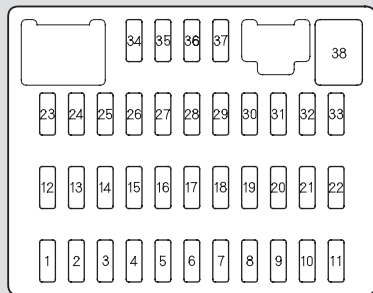

No.	Amps.	Circuits Protected
1	7.5 A	Power Window
2	15 A	Fuel Pump
3	10 A	IG1 ACG
4	7.5 A	ABS
5	15 A	Audio Amp*
6	20 A	Front Fog Lights*
7	—	Not Used
8	—	Not Used

No.	Amps.	Circuits Protected
9	7.5 A	ODS (Occupant Detection System)
10	7.5 A	Meter
11	10 A	SRS
12	10 A	Right Headlight High Beam
13	10 A	Left Headlight High Beam
14	7.5 A	Small Lights (Interior)
15	7.5 A	Small Lights (Exterior)
16	10 A	Right Headlight Low Beam

No.	Amps.	Circuits Protected
17	10 A	Left Headlight Low Beam
18	20 A	Headlight High Beam Main
19	15 A	Small Lights Main
20	—	Not Used
21	20 A	Headlight Low Beam Main
22	—	Not Used
23	—	Not Used
24	20 A	Moonroof*
25	20 A	Door Lock
26	20 A	Driver's Power Window
27	20 A	HAC Option
28	15 A	Rear Accessory Socket*
29	15 A	Accessory
30	20 A	Front Passenger's Power Window
31	—	Not Used
32	—	Not Used
33	—	Not Used
34	—	Not Used
35	7.5 A	Accessory, Radio
36	10 A	IG2 HAC
37	7.5 A	Daytime Running Lights
38	30 A	Front Wiper

\* : If equipped



# Emergency Towing

---

If your vehicle needs to be towed, call a professional towing service or organization. Never tow your vehicle with just a rope or chain. It is very dangerous.

There are two ways to tow your vehicle:

**Flat-bed Equipment** — The operator loads your vehicle on the back of a truck. **This is the best way to transport your vehicle.**

**Wheel-lift Equipment** — The tow truck uses two pivoting arms that go under the front tires and lift them off the ground. The rear tires remain on the ground. **This is an acceptable way to tow your vehicle.**

If, due to damage, your vehicle must be towed with the front wheels on the ground, do this:

*Manual Transmission:*

- Release the parking brake.
- Shift the transmission to neutral.
- Leave the ignition switch in the ACCESSORY (I) position so the steering wheel does not lock.

*Automatic Transmission:*

- Release the parking brake.
- Start the engine.
- Shift to D, then to N.
- Turn off the engine.
- Leave the ignition switch in the ACCESSORY (I) position so the steering wheel does not lock.

## NOTICE

*Improper towing preparation will damage the transmission. Follow the above procedure exactly. If you cannot shift the transmission or start the engine (automatic transmission), your vehicle must be transported with the front wheels off the ground.*

With the front wheels on the ground, do not tow the vehicle more than 50 miles (80 km), and keep the speed below 35 mph (55 km/h).

Do not tie down the vehicle at an angle that would allow the towing cables to contact the vehicle's front bumper. To avoid possible damage, protect the front bumper with tape.

If your vehicle is equipped with a front spoiler, remove it before towing so it is not damaged.

**NOTICE**

*Trying to lift or tow your vehicle by the bumpers will cause serious damage. The bumpers are not designed to support the vehicle's weight.*

**NOTICE**

*The steering system can be damaged if the steering wheel is locked. Leave the ignition switch in the ACCESSORY (I) position, and make sure the steering wheel turns freely before you begin towing.*

The diagrams in this section give you the dimensions and capacities of your vehicle, and the locations of the identification numbers. It also includes information you should know about your vehicle's tires and emissions control systems.

Identification Numbers.....	276	Emissions Controls.....	283
Specifications .....	278	The Clean Air Act.....	283
DOT Tire Quality Grading		Crankcase Emissions Control	
(U.S. Vehicles) .....	280	System.....	283
Uniform Tire Quality		Evaporative Emissions Control	
Grading .....	280	System.....	283
Treadwear .....	280	Onboard Refueling Vapor	
Traction.....	280	Recovery .....	283
Temperature .....	281	Exhaust Emissions Controls ...	284
Tire Labeling.....	282	PGM-FI System .....	284
		Ignition Timing Control	
		System.....	284
		Exhaust Gas Recirculation	
		(EGR)System.....	284
		Three Way Catalytic	
		Converter.....	284
		Replacement Parts.....	284
		Three Way Catalytic Converter...	285
		State Emissions Testing .....	286

# Identification Numbers

Your vehicle has several identifying numbers located in various places.

The vehicle identification number (VIN) is the 17-digit number your dealer uses to register your vehicle for warranty purposes. It is also necessary for licensing and insuring your vehicle. The easiest place to find the VIN is on a plate fastened to the top of the dashboard. You can see it by looking through the windshield on the driver's side. It is also on the certification label attached to the driver's doorjamb, and is stamped on the engine compartment bulkhead. The VIN is also provided in bar code on the certification label.

To access the VIN in the engine compartment, slide the lid on the back of the engine compartment. Make sure to close the lid before closing the hood.

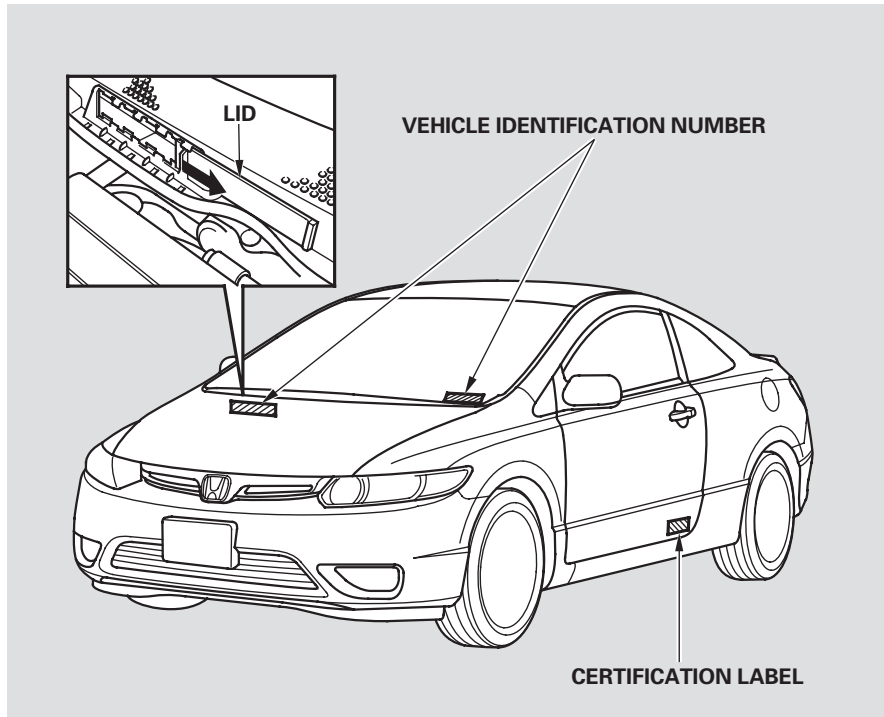

The engine number is stamped into the engine block. It is on the front.

The transmission number is on a label on top of the transmission.

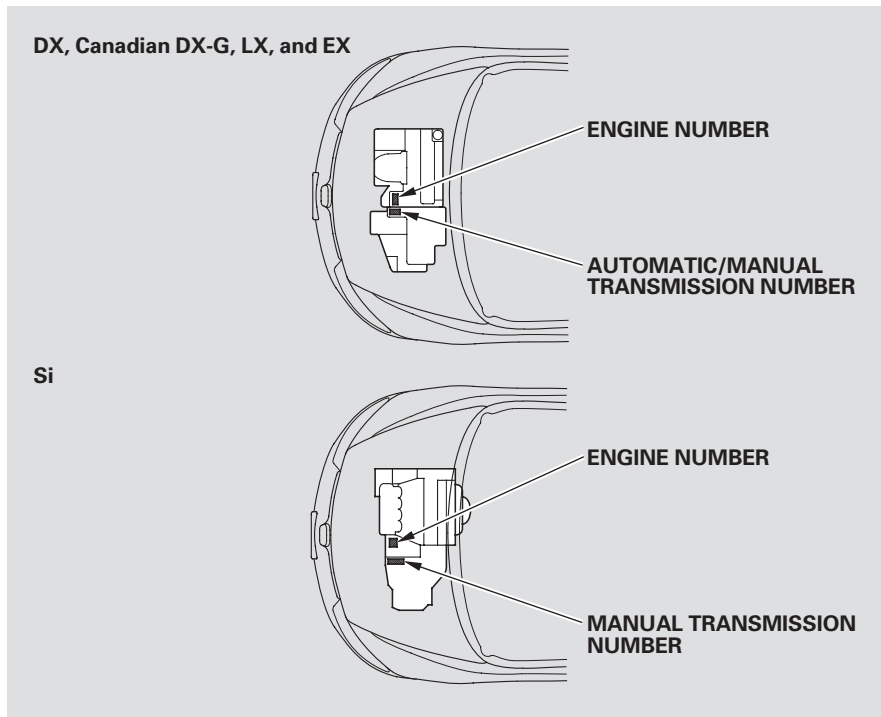

# Specifications

## Dimensions

Length	174.8 in (4,440 mm)
Width	68.9 in (1,751 mm)
Height	55.0 in (1,396 mm)
Wheelbase	104.3 in (2,650 mm)
Track	59.0 in (1,499 mm)
Front	
Rear	60.1 in (1,526 mm)

## Weights

Gross vehicle weight rating	See the certification label attached to the driver's doorjamb.
-----------------------------	--

## Engine

Type	Water cooled 4-stroke SOHC VTEC* <sup>1</sup> , DOHC i-VTEC* <sup>2</sup> 4-cylinder gasoline engine
Bore x Stroke	3.19 x 3.44 in (81.0 x 87.3 mm) 3.39 x 3.39 in (86 x 86 mm)
Displacement	110 cu-in (1,799 cm <sup>3</sup> ) * <sup>1</sup> 122 cu-in (1,998 cm <sup>3</sup> ) * <sup>2</sup>
Compression ratio	10.5 * <sup>1</sup> 11.0 * <sup>2</sup>
Spark plugs* <sup>1</sup>	NGK: IZFR6K-11S DENSO: SKJ20DR-M11S
Spark plugs* <sup>2</sup>	NGK: IFR7G-11KS DENSO: SK22PR-M11S

\* 1 : DX, Canadian DX-G, LX, EX

\* 2 : Si

## Capacities

Fuel tank		Approx. 13.2 US gal (50 ℓ)
Engine coolant	Change* <sup>1</sup>	A/T 1.45 US gal (5.5 ℓ)* <sup>3</sup>
		M/T 1.37 US gal (5.2 ℓ)* <sup>3</sup> 1.19 US gal (4.5 ℓ)* <sup>4</sup>
	Total	A/T 1.88 US gal (7.1 ℓ)* <sup>3</sup>
		M/T 1.72 US gal (6.5 ℓ)* <sup>3</sup> 1.80 US gal (6.8 ℓ)* <sup>4</sup>
Engine oil	Change* <sup>2</sup>	Including filter 3.9 US qt (3.7 ℓ)* <sup>3</sup> 4.6 US qt (4.4 ℓ)* <sup>4</sup>
		Without filter 3.7 US qt (3.5 ℓ)* <sup>3</sup> 4.4 US qt (4.2 ℓ)* <sup>4</sup>
	Total	4.8 US qt (4.5 ℓ)* <sup>3</sup> 5.8 US qt (5.5 ℓ)* <sup>4</sup>
		Manual transmission fluid
Total	1.7 US qt (1.6 ℓ)* <sup>3</sup> 1.8 US qt (1.7 ℓ)* <sup>4</sup>	
	Automatic transmission fluid	Change 2.5 US qt (2.4 ℓ)
Total		6.2 US qt (5.9 ℓ)
Windshield washer reservoir	U.S. Vehicles	2.6 US qt (2.5 ℓ)
	Canada Vehicles	4.8 US qt (4.5 ℓ)

\* 1 : Including the coolant in the reserve tank and that remaining in the engine

Reserve tank capacity: 0.11 US gal (0.4 ℓ)

\* 2 : Excluding the oil remaining in the engine

\* 3 : U.S.: DX, LX, EX      Canada: DX, DX-G, LX, EX

\* 4 : Si

## Air Conditioning

Refrigerant type	HFC-134a (R-134a)
Charge quantity	14.1 – 15.9 oz (400 – 450 g)
Lubricant oil type	SP-10

## Lights

Headlights (HI)	12 V – 60 W (HB3)
Headlights (LO)	12 V – 51 W (HB4)
Front turn signal/Side marker/ Parking light	12 V – 28/8 W
Rear turn signal lights	12 V – 21 W
Stop/Taillights	12 V – 21/5 W
Rear side marker lights	12 V – 3 CP
Back-up lights	12 V – 18 W
High-mount brake light*	12 V – 21 W
License plate lights	12 V – 3 CP
Ceiling light	12 V – 8 W
Spotlights	12 V – 8 W
Trunk light	12 V – 5 W

\* : All models except for EX and Si

## Battery

Capacity	12 V – 36 AH/5 HR *1
	12 V – 38 AH/5 HR *2
	12 V – 45 AH/20 HR *1
	12 V – 47 AH/20 HR *3

\* 1 : U.S.: DX, LX, EX

\* 2 : Canada: DX, DX-G, LX, EX

\* 3 : Si

## Fuses

Interior	See page 271 or the fuse label attached to the dashboard.
Under-hood	See page 270 or the fuse box cover.

## Alignment

Toe-in	Front	0.00 in (0.0 mm)
	Rear	0.08 in (2.0 mm)
Camber	Front	0°
	Rear	– 1°30'
Caster	Front	7°

## Tires

Size	Front/Rear	P195/65R15 89H *1 P205/55R16 89H *2 P215/45R17 87V *3 215/45R17 91W *5
	Spare	T125/70D15 95M *4 T125/70D16 96M *6
Pressure	Front/Rear	30 psi (210 kPa , 2.1 kgf/cm <sup>2</sup> )*1 32 psi (220 kPa , 2.2 kgf/cm <sup>2</sup> )*2, *5
	Front*3	32 psi (220 kPa , 2.2 kgf/cm <sup>2</sup> )
	Rear*3	29 psi (200 kPa , 2.0 kgf/cm <sup>2</sup> )
	Spare	60 psi (420 kPa , 4.2 kgf/cm <sup>2</sup> )

\* 1 : U.S. DX, Canada DX, DX-G

\* 2 : LX, EX

\* 3 : Si (all season tires)

\* 4 : U.S.: DX, LX, EX, Canada: DX, DX-G, LX, EX

\* 5 : Optional for Si (summer tires)

\* 6 : Si

# DOT Tire Quality Grading (U.S. Vehicles)

---

The tires on your vehicle meet all U.S. Federal Safety Requirements. All tires are also graded for treadwear, traction, and temperature performance according to Department of Transportation (DOT) standards. The following explains these gradings.

## Uniform Tire Quality Grading

Quality grades can be found where applicable on the tire sidewall between the tread shoulder and the maximum section width. For example:

**Treadwear 200**  
**Traction AA**  
**Temperature A**

All passenger car tires must conform to Federal Safety Requirements in addition to these grades.

## Treadwear

The treadwear grade is a comparative rating based on the wear rate of the tire when tested under controlled conditions on a specified government test course. For example, a tire graded 150 would wear one and one-half (1 1/2) times as well on the government course as a tire graded 100. The relative performance of tires depends upon the actual conditions of their use, however, and may depart significantly from the norm due to variations in driving habits, service practices, and differences in road characteristics and climate.

## Traction – AA, A, B, C

The traction grades, from highest to lowest, are AA, A, B, and C. Those grades represent the tire's ability to stop on wet pavement as measured under controlled conditions on specified government test surfaces of asphalt and concrete. A tire marked C may have poor traction performance.

**Warning:** The traction grade assigned to this tire is based on straight-ahead braking traction tests, and does not include acceleration, cornering, hydroplaning, or peak traction characteristics.



## Temperature – A, B, C

The temperature grades are A (the highest), B, and C, representing the tire's resistance to the generation of heat, and its ability to dissipate heat when tested under controlled conditions on a specified indoor laboratory test wheel. Sustained high temperature can cause the material of the tire to degenerate and reduce tire life, and excessive temperature can lead to sudden tire failure. Grade C corresponds to a level of performance that all passenger car tires must meet under the Federal Motor Vehicle Safety Standard No. 109. Grades B and A represent higher levels of performance on the laboratory test wheel than the minimum required by law.

**Warning:** The temperature grade for this tire is established for a tire that is properly inflated and not overloaded. Excessive speed, underinflation, or excessive loading, either separately or in combination, can cause heat buildup and possible tire failure.

# Tire Labeling

---

The tires that came on your vehicle have a number of markings. Those you should be aware of are described below.

## *Tire Size*

Whenever tires are replaced, they should be replaced with tires of the same size. Below is an example of tire size with an explanation of what each component means.

P205/55R16 89H

P — Vehicle type (P indicates passenger vehicle).

205 — Tire width in millimeters.

55 — Aspect ratio (the tire's section height as a percentage of its width).

R — Tire construction code (R indicates radial).

16 — Rim diameter in inches.

89 — Load index (a numerical code associated with the maximum load the tire can carry).

H — Speed symbol (an alphabetical code indicating the maximum speed rating).

## *Tire Identification Number*

The tire identification number (TIN) is a group of numbers and letters that look like this example:  
DOT B97R FW6X 2202

DOT — This indicates that the tire meets all requirements of the U.S. Department of Transportation.

B97R — Manufacturer's identification mark.

FW6X — Tire type code.

2202 — Date of manufacture.

## *Maximum Tire Pressure*

Max Press — The maximum air pressure the tire can hold.

## *Maximum Tire Load*

Max Load — The maximum load the tire can carry at maximum air pressure.

The burning of gasoline in your vehicle's engine produces several by-products. Some of these are carbon monoxide (CO), oxides of nitrogen (NOx), and hydrocarbons (HC). Gasoline evaporating from the tank also produces hydrocarbons. Controlling the production of NOx, CO, and HC is important to the environment. Under certain conditions of sunlight and climate, NOx and HC react to form photochemical "smog." Carbon monoxide does not contribute to smog creation, but it is a poisonous gas.

## **The Clean Air Act**

The United States Clean Air Act\* sets standards for automobile emissions. It also requires that automobile manufacturers explain to owners how their emissions controls work and what to do to maintain them. This section summarizes how the emissions controls work.

\* In Canada, Honda vehicles comply with the Canadian emission requirements, as specified in an agreement with Environment Canada, at the time they are manufactured.

## **Crankcase Emissions Control System**

Your vehicle has a positive crankcase ventilation system. This keeps gasses that build up in the engine's crankcase from going into the atmosphere. The positive crankcase ventilation valve routes them from the crankcase back to the

intake manifold. They are then drawn into the engine and burned.

## **Evaporative Emissions Control System**

As gasoline evaporates in the fuel tank, an evaporative emissions control canister filled with charcoal adsorbs the vapor. It is stored in this canister while the engine is off. After the engine is started and warmed up, the vapor is drawn into the engine and burned during driving.

## **Onboard Refueling Vapor Recovery**

The onboard refueling vapor recovery (ORVR) system captures the fuel vapors during refueling. The vapors are adsorbed in a canister filled with activated carbon. While driving, the fuel vapors are drawn into the engine and burned off.

# Emissions Controls

---

## **Exhaust Emissions Controls**

The exhaust emissions controls include three or four systems: PGM-FI, ignition timing control, exhaust gas recirculation (DX, LX, and EX), and three way catalytic converter. These systems work together to control the engine's combustion and minimize the amount of HC, CO, and NOx that comes out the tailpipe. The exhaust emissions control systems are separate from the crankcase and evaporative emissions control systems.

### ***PGM-FI System***

The PGM-FI system uses sequential multiport fuel injection. It has three subsystems: air intake, engine control, and fuel control. The powertrain control module (PCM) in automatic transmission vehicles or the engine control module (ECM) in manual transmission vehicles uses various sensors to determine how much air is going into the engine. It

then controls how much fuel to inject under all operating conditions.

### ***Ignition Timing Control System***

This system constantly adjusts the ignition timing, reducing the amount of HC, CO, and NOx produced.

### ***Exhaust Gas Recirculation (EGR) System***

*On DX, LX, and EX models*

The exhaust gas recirculation (EGR) system takes some of the exhaust gas and routes it back into the intake manifold. Adding exhaust gas to the air/fuel mixture reduces the amount of NOx produced when the fuel is burned.

### ***Three Way Catalytic Converter***

The three way catalytic converter is in the exhaust system. Through chemical reactions, it converts HC, CO, and NOx in the engine's exhaust to carbon dioxide (CO<sub>2</sub>), nitrogen (N<sub>2</sub>), and water vapor.

## **Replacement Parts**

The emissions control systems are designed and certified to work together in reducing emissions to levels that comply with the Clean Air Act. To make sure the emissions remain low, you should use only new Honda replacement parts or their equivalent for repairs. Using lower quality parts may increase the emissions from your vehicle.

The emissions control systems are covered by warranties separate from the rest of your vehicle. Read your warranty manual for more information.

**DX, Canadian DX-G, LX, EX**

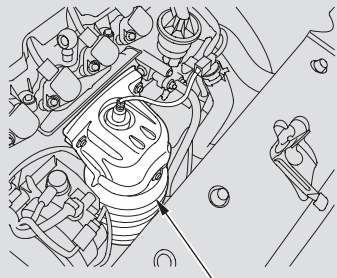

**THREE WAY CATALYTIC CONVERTER**

The three way catalytic converter contains precious metals that serve as catalysts, promoting chemical reactions to convert the exhaust gasses without affecting the metals. The catalytic converter is referred to as a three-way catalyst, since it acts on HC, CO, and NO<sub>x</sub>. A replacement unit must be an original Honda part or its equivalent.

The three way catalytic converter must operate at a high temperature

**Si model**

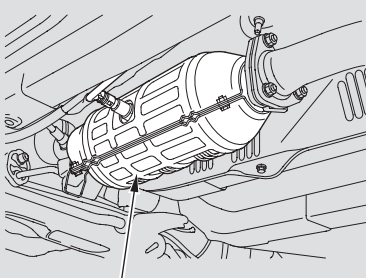

**THREE WAY CATALYTIC CONVERTER**

for the chemical reactions to take place. It can set on fire any combustible materials that come near it. Park your vehicle away from high grass, dry leaves, or other flammables.

A defective three way catalytic converter contributes to air pollution, and can impair your engine's performance. Follow these guidelines to protect your vehicle's three way catalytic converter.

- Always use unleaded gasoline. Even a small amount of leaded gasoline can contaminate the catalyst metals, making the three way catalytic converter ineffective.
- Keep the engine tuned-up.
- Have your vehicle diagnosed and repaired if it is misfiring, back-firing, stalling, or otherwise not running properly.

# State Emissions Testing

---

## Testing of Readiness Codes

If you take your vehicle for a state emissions test shortly after the battery has been disconnected or gone dead, it may not pass the test. This is because of certain “readiness codes” that must be set in the on-board diagnostics for the emissions systems. These codes are erased when the battery is disconnected, and set again only after several days of driving under a variety of conditions.

If the testing facility determines that the readiness codes are not set, you will be requested to return at a later date to complete the test. If you must get the vehicle retested within the next two or three days, you can condition the vehicle for retesting by doing the following.

- Make sure the gas tank is nearly, but not completely full (around 3/4).

- Make sure the vehicle has been parked with the engine off for 6 hours or more.
- Make sure the ambient temperature is between 40° and 95°F.
- Without touching the accelerator pedal, start the engine, and let it idle for 20 seconds.
- Keep the vehicle in Park (automatic transmission) or neutral (manual transmission). Increase the engine speed to 2,000 rpm, and hold it there until the temperature gauge rises to at least 1/4 of the scale (about 3 minutes).
- Select a nearby lightly traveled major highway where you can maintain a speed of 50 to 60 mph (80 to 97 km/h) for at least 20 minutes. Drive on the highway in D (A/T) or 5th (M/T). Do not use

the cruise control. When traffic allows, drive for 90 seconds without moving the accelerator pedal. (Vehicle speed may vary slightly; this is okay.) If you cannot do this for a continuous 90 seconds because of traffic conditions, drive for at least 30 seconds, then repeat it two more times (for a total of 90 seconds).

- Then drive in city/suburban traffic for at least 10 minutes. When traffic conditions allow, let the vehicle coast for several seconds without using the accelerator pedal or the brake pedal.
- Stop the vehicle, turn off the ignition switch, and leave it off for 30 minutes.

If the testing facility determines the readiness codes are still not set, see your dealer.

Customer Service Information.....	288
Warranty Coverages .....	289
Reporting Safety Defects (U.S. Vehicles) .....	290
Authorized Manuals.....	291

# Customer Service Information

---

Honda dealership personnel are trained professionals. They should be able to answer all your questions. If you encounter a problem that your dealership does not solve to your satisfaction, please discuss it with the dealership's management. The service manager or general manager can help. Almost all problems are solved in this way.

If you are dissatisfied with the decision made by the dealership's management, contact your Honda Customer Service Office.

## U.S. Owners:

American Honda Motor Co., Inc.  
Automobile Customer Service  
Mail Stop 500-2N-7A  
1919 Torrance Boulevard  
Torrance, California 90501-2746

Tel: (800) 999-1009

## Canadian Owners:

### **CUSTOMER RELATIONS RELATIONS AVEC LA CLIENTÈLE**

Honda Canada Inc.  
715 Milner Avenue  
Toronto, ON  
M1B 2K8

Tel: 1-888-9-HONDA-9  
Fax: Toll-free 1-877-939-0909  
Toronto (416) 287-4776

## In Puerto Rico and the U.S. Virgin Islands:

Bella International  
P.O. Box 190816  
San Juan, PR 00919-0816

Tel: (787) 620-7028

When you call or write, please give us this information:

- Vehicle identification number (see page [276](#))
- Name and address of the dealer who services your vehicle
- Date of purchase
- Mileage on your vehicle
- Your name, address, and telephone number
- A detailed description of the problem
- Name of the dealer who sold the vehicle to you



## U.S. Owners

Your new vehicle is covered by these warranties:

***New Vehicle Limited Warranty*** — covers your new vehicle, except for the battery, emissions control systems, and accessories against defects in materials and workmanship.

***Emissions Control Systems Defects Warranty and Emissions Performance Warranty*** — these two warranties cover your vehicle's emissions control systems. Time, mileage, and coverage are conditional. Please read your warranty booklet for exact information.

***Original Equipment Battery Limited Warranty*** — this warranty gives up to 100 percent credit toward a replacement battery.

***Seat Belt Limited Warranty*** — a seat belt that fails to function properly is covered for the useful life of the vehicle.

***Rust Perforation Limited Warranty*** — all exterior body panels are covered for rust-through from the inside for the specified time period with no mileage limit.

***Accessory Limited Warranty*** — Honda accessories are covered under this warranty. Time and mileage limits depend on the type of accessory and other factors. Please read your warranty booklet for details.

***Replacement Parts Limited Warranty*** — covers all Honda replacement parts against defects in materials and workmanship.

***Replacement Battery Limited Warranty*** — provides prorated coverage for a replacement battery purchased from your dealer.

***Replacement Muffler Lifetime Limited Warranty*** — provides coverage for as long as the purchaser of the muffler owns the vehicle.

Restrictions and exclusions apply to all these warranties. Please read the 2006 Honda warranty information booklet that came with your vehicle for precise information on warranty coverages. Your vehicle's original tires are covered by their manufacturer. Tire warranty information is in a separate booklet.

## Canadian Owners

Please refer to the 2006 warranty manual that came with your vehicle.

## Reporting Safety Defects (U.S. Vehicles)

---

If you believe that your vehicle has a defect which could cause a crash or could cause injury or death, you should immediately inform the National Highway Traffic Safety Administration (NHTSA) in addition to notifying American Honda Motor Co., Inc.

If NHTSA receives similar complaints, it may open an investigation, and if it finds that a safety defect exists in a group of vehicles, it may order a recall and remedy campaign. However, NHTSA cannot become involved in individual problems between you, your dealer, or American Honda Motor Co., Inc.

To contact NHTSA, you may call the Vehicle Safety Hotline toll-free at 1-888-327-4236 (TTY 1-800-424-9153); go to <http://www.safercar.gov>; or write to: Administrator, NHTSA, 400 Seventh Street, SW., Washington, DC 20590. You can also obtain other information about motor vehicle safety from <http://www.safercar.gov>.

## Purchasing Factory Authorized Manuals (U.S. only)

The publications shown below can be purchased from Helm Incorporated. You can order in any of three ways:

- Detach and mail the order form on the right half of this page
- Call Helm Inc. at 1-800-782-4356 (credit card orders only)
- Go online at [www.helminc.com](http://www.helminc.com)

If you are interested in other years or models, contact Helm Inc. at 1-800-782-4356.

Publication Form Number	Form Description	Price Each*
61SNA00	2006 Honda Civic 2/4 door Service Manual	\$75.00
61SNA00EL	2006 Honda Civic 2/4 door Electrical Troubleshooting Manual	\$50.00
61SNA30	2006 Honda Civic 2/4 door Body Repair Manual	\$44.00
31SVA600	2006 Honda Civic 2-door Owner's Manual	\$35.00
31SNA700	2006 Honda Civic Navigation System Manual	\$29.00
31SNAM00	2006 Honda Civic Honda Service History	\$12.00
31SVAQ00	2006 Honda Civic 2-door Quick Start Guide	\$12.00
HON-R	Order Form for Previous Years Indicate Year and Model Desired	FREE

\* Prices are subject to change without notice and without incurring obligation.

*Valid only for sales within the United States. Canadian owners should contact their authorized Honda dealer.*

**ORDER TOLL FREE: 1-800-782-4356**

**(NOTE: For Credit Card Holder Orders Only)**

Monday-Friday 8:00 A.M. — 6:00 P.M. EST

**MINIMUM CREDIT CARD PURCHASE \$10.00**

**OR**

By completing this form you can order the materials desired. You can pay by check or money order, or charge to your credit card. Mail to Helm Incorporated at the address shown on the back of the order form.

2006 HON	PUBLICATION NUMBER	VEHICLE MODEL		Qty	Price Each*	Total Price
		Name	Year			
* Prices are subject to change without notice and without incurring obligation.					TOTAL MATERIAL	
					Mich. Purchases Add 6% Sales Tax	
Orders are mailed within 10 days. Please allow adequate time for delivery.					HANDLING CHARGE \$6.95	
					GRAND TOTAL	

S H I P  T O	NOTE: Dealers and companies, please provide dealer or company name, and the name of the person to whose attention the shipment should be sent. For purchases outside U.S.A. please write to the address shown below for a quotation.	
	_____	_____
	Customer Name	Attention
	_____	_____
	Street Address – No P.O. Box Number	Apartment Number
_____	_____	
City	State & Zip Code	
Daytime Telephone Number (     ) _____		

P A Y M E N T	<input type="checkbox"/> Check or money order enclosed payable to Helm Inc – U.S. funds only. Do not send cash					
	<input type="checkbox"/> Master Card <input type="checkbox"/> VISA <input type="checkbox"/> Check here if your billing address is different from the shipping address shown above.					
	Account Number _____     Expiration: Mo. Yr. _____					
	<table border="1" style="width: 100%; border-collapse: collapse;"><tr><td style="width: 25%; height: 20px;"> </td><td style="width: 25%; height: 20px;"> </td><td style="width: 25%; height: 20px;"> </td><td style="width: 25%; height: 20px;"> </td><td style="width: 25%; height: 20px;"> </td></tr></table>					
	_____					
CUSTOMER SIGNATURE     DATE						

These publications cannot be returned for credit without receiving advance authorization within 14 days of delivery. On returns, a restocking fee may be applied against the original order.

**HELM** P.O. BOX 07280-DETROIT, MICHIGAN 48207-1-800-782-4356

## Service Manual:

This manual covers maintenance and recommended procedures for repair to engine and chassis components. It is written for the journeyman mechanic, but is simple enough for most mechanically-inclined owners to understand.

## Electrical Troubleshooting Manual:

This manual complements the service manual by providing in-depth troubleshooting information for each electrical circuit in your vehicle.

## Body Repair Manual:

This manual describes the procedures involved in the replacement of damaged body parts.

## A

Accessories and Modifications ....	186
ACCESSORY (Ignition Key Position) .....	76
Accessory Power Sockets.....	104
Adding Engine Coolant .....	224
Additives, Engine Oil.....	221
Adjusting the Steering Wheel.....	73
Advice for Pregnant Women.....	16
Airbag (SRS) .....	9, 21
Air Conditioning System.....	110
Usage .....	113
Air Pressure, Tires .....	242
Alcohol in Gasoline.....	180
Antifreeze .....	224
Anti-lock Brakes (ABS) Indicator.....	59, 204
Operation .....	204
Anti-theft, Audio System.....	172
Anti-theft Steering Column Lock.....	76
Audio System .....	115
Auto Door Locking/Unlocking.....	78
Automatic Seat Belt Tensioners ....	19
Automatic Speed Control.....	175

Automatic Transmission.....	198
Capacity, Fluid .....	278
Checking Fluid Level.....	228
Shifting.....	198
Shift Lever Position Indicators.....	198
Shift Lever Positions .....	198
Shift Lock Release.....	201

## B

Battery Charging System Indicator.....	57, 263
Jump Starting .....	259
Maintenance.....	248
Specifications .....	279
Before Driving .....	179
Belts, Seat .....	8, 18
Beverage Holders .....	103
Booster Seats .....	47
Brakes Anti-lock System (ABS) .....	204
Break-in, New Linings .....	180
Bulb Replacement .....	236
Fluid .....	230

Parking.....	101
System Design .....	203
System Indicator.....	58, 265
Wear Indicators .....	203
Braking System.....	203
Break-in, New Vehicle .....	180
Brightness Control, Instruments...	71
Brights, Headlights .....	70
Bulb Replacement Back-up Lights .....	236
Brake Lights.....	236
Front Parking Lights.....	235
Front Side Marker Lights.....	235
Headlights .....	232
High-mount Brake Light .....	237
Specifications .....	279
Turn Signal Lights.....	235
Bulbs, Halogen.....	232

## C

Capacities Chart.....	278
Carbon Monoxide Hazard .....	50
Carrying Cargo .....	188

CONTINUED

# Index

- CAUTION, Explanation of ..... **ii**  
CD Care ..... **169**  
CD Changer ..... **131, 153**  
CD Changer Error Messages ..... **133**  
CD Player ..... **126, 146**  
CD Player Error Messages .. **132, 154**  
Ceiling Light ..... **106**  
Certification Label ..... **276**  
Chains, Tires ..... **247**  
Changing a Flat Tire ..... **253**  
Changing Oil  
    How to ..... **222**  
    When to ..... **209**  
Charging System Indicator .... **57, 263**  
Check Fuel Cap Indicator ..... **66**  
Checklist, Before Driving ..... **193**  
Child Safety ..... **32**  
    Booster Seats ..... **47**  
    Child Seats ..... **39**  
    Important Safety  
        Reminders ..... **32, 35**  
    Infants ..... **37**  
    Large Children ..... **46**  
    LATCH ..... **41**  
    Risks with Airbags ..... **33**  
    Small Children ..... **38**  
    Tethers ..... **45**  
    Warning Labels ..... **51**  
    Where Should a Child Sit? ..... **33**  
Child Seats  
    Installing ..... **40**  
    Lower Anchors ..... **41**  
    Selecting ..... **39**  
    Tether Anchor Points ..... **45**  
Cleaning  
    Seat Belts ..... **237**  
Clock ..... **173**  
Clutch Fluid ..... **231**  
CO in the Exhaust ..... **283**  
Coat Hook ..... **104**  
Cold Weather, Starting in ..... **194**  
Compact Spare Tire ..... **252**  
Console Compartment ..... **103**  
Consumer Information ..... **288**  
Controls, Instruments and ..... **53**  
Coolant  
    Adding ..... **224**  
    Checking ..... **185**  
    Proper Solution ..... **224**  
    Temperature Gauge ..... **66**  
Crankcase Emissions Control  
    System ..... **283**  
Cruise Control Indicator ..... **61**  
Cruise Control Operation ..... **175**  
Cup Holders ..... **103**  
Customer Service Information ..... **288**
- D**
- DANGER, Explanation of ..... **ii**  
Dashboard ..... **3, 54**  
Daytime Running Lights ..... **71**  
Daytime Running Lights  
    Indicator ..... **61**  
Dead Battery ..... **259**  
Defects, Reporting Safety ..... **290**  
Defogger, Rear Window ..... **72**  
Defrosting the Windows ..... **114**  
Dimensions ..... **278**  
Dimming the Headlights ..... **70**  
Dipstick  
    Automatic Transmission ..... **228**  
    Engine Oil ..... **183**  
Directional Signals ..... **70**  
Disc Brake Wear Indicators ..... **203**  
Disc Care ..... **169**  
Disc Player ..... **126, 146**  
Display Change Button ..... **64**

Disposal of Used Oil.....	224
Doors	
Auto Door Locking/Unlocking..	78
Locking and Unlocking.....	77
Power Door Locks.....	78
DOT Tire Quality Grading* .....	280
Downshifting, Manual	
Transmission.....	195
Driver and Passenger Safety.....	5
Driving .....	191
Economy .....	185
Dust and Pollen Filter .....	239
<b>E</b>	
Economy, Fuel .....	185
Emergencies.....	251
Battery, Jump Starting .....	259
Brake System Indicator .....	265
Changing a Flat Tire .....	253
Charging System Indicator .....	263
Checking the Fuses.....	266
Hazard Warning Flashers .....	72
Jump Starting .....	259
Low Oil Pressure Indicator .....	263
Malfunction Indicator Lamp ....	264

Overheated Engine .....	261
Towing .....	272
Emergency Brake.....	101
Emergency Flashers .....	72
Emergency Towing.....	272
Emergency Trunk Opener .....	89
Emissions Controls.....	283
Emissions Testing, State .....	286
Engine	
Adding Engine Coolant.....	224
Coolant Temperature Gauge ....	66
If It Won't Start .....	257
Malfunction Indicator	
Lamp .....	57, 264
Oil Life Indicator.....	209
Oil Pressure Indicator .....	57, 263
Oil, Synthetic.....	221
Oil, What Kind to Use .....	220
Overheating.....	261
Specifications .....	278
Speed Limiter.....	197, 200
Starting.....	194
Ethanol in Gasoline .....	180
Evaporative Emissions Controls..	283
Exhaust Fumes .....	50

Expectant Mothers, Use of Seat	
Belts by .....	16

**F**

Fan Control.....	111
Features.....	109
Filling the Fuel Tank.....	181
Filters	
Dust and Pollen.....	239
Oil .....	222
Flashers, Hazard Warning.....	72
Flat Tire, Changing a .....	253
Fluids	
Automatic Transmission.....	228
Brake .....	230
Clutch.....	230
Manual Transmission .....	229
Power Steering.....	231
Windshield Washer .....	227
FM Stereo Radio	
Reception .....	167
Folding Rear Seat .....	94
Four-way Flashers .....	72

CONTINUED

# Index

Front Airbags.....	9, 23
Front Seat	
Adjusting.....	90
Airbags.....	9, 23
Fuel.....	180
Check Fuel Cap Indicator.....	66
Economy.....	185
Fill Door and Cap.....	181
Gauge.....	66
Low Fuel Indicator.....	62
Octane Requirement.....	180
Oxygenated.....	180
Tank, Refueling.....	181
Fuse Locations.....	270
Fuses, Checking the.....	266

## G

Gas Mileage, Improving.....	185
Gasohol.....	180
Gasoline.....	180
Gauge.....	66
Low Fuel Indicator.....	62
Octane Requirement.....	180
Tank, Refueling.....	181
Gas Station Procedures.....	181

Gauges	
Engine Coolant Temperature ....	66
Fuel.....	66
Gearshift Lever Positions	
Automatic Transmission.....	198
Manual Transmission.....	196
Glove Box.....	103
Gross Axle Weight Rating (GAWR).....	189
Gross Vehicle Weight Rating (GVWR).....	189

## H

Halogen Headlight Bulbs.....	232
Hazard Warning Flashers.....	72
Headlights	
Aiming.....	232
Daytime Running Lights.....	71
High Beam Indicator.....	61
Reminder Beeper.....	70
Replacing Halogen Bulbs.....	232
Turning on.....	70
Head Restraints.....	93
Heated Mirrors.....	101
Heating and Cooling.....	110

High Altitude, Starting at.....	194
High Beam Lever.....	70
High-mount Brake Light.....	237
Hood, Opening and Closing the... ..	182
Horn.....	68
Hydraulic Clutch.....	231

## I

Identification Number, Vehicle....	276
If the Engine Overheats.....	261
If the Engine Wont Start.....	257
Ignition	
Keys.....	74
Switch.....	76
Timing Control System.....	284
Immobilizer System.....	75
Important Safety Precautions.....	6
Indicators	
ABS (Anti-Lock Brake).....	59
Brake (Parking and Brake System).....	58
Charging System.....	57, 263
Cruise Control.....	61
DRL (Daytime Running Lights).....	61



- High Beam..... 61  
 Key (Immobilizer System) ..... 59  
 Lights ON ..... 62  
 Low Fuel ..... 62  
 Low Oil Pressure ..... 57, 263  
 Maintenance Minder..... 60, 209  
 Malfunction Lamp ..... 264  
 REV Limit ..... 60  
 Security System ..... 62  
 Side Airbag Off ..... 58  
 SRS ..... 58  
 Trunk Open..... 61  
 Turn Signal and Hazard  
   Warning ..... 59  
 Washer Level ..... 61  
 Indicators, Instrument  
   Panel..... 55, 57  
 Infant Restraint ..... 37  
 Infant Seats  
   Installing ..... 40  
   Tether Anchor Points ..... 45  
 Inflation, Proper Tire ..... 242  
 Information Display..... 63  
 Inside Mirror ..... 100  
 Inspection, Tire ..... 243  
 Installing a Child Seat ..... 40  
 Instrument Panel ..... 3, 54  
 Instrument Panel Brightness ..... 71  
 Instrument and Controls..... 53  
 Interior Lights ..... 106  
 Introduction ..... i  
**J**  
 Jacking up the Vehicle ..... 254  
 Jack, Tire ..... 253  
 Jump Starting ..... 259  
**K**  
 Keys..... 74  
**L**  
 Label, Certification..... 276  
 Lane Change, Signaling ..... 70  
 Lap/Shoulder Belts ..... 14, 19  
 LATCH System..... 41  
 Lights  
   Bulb Replacement ..... 232  
   Indicators..... 55, 57  
   Parking..... 70  
 Turn Signal ..... 70  
 Load Limits..... 189  
 LOCK (Ignition Key Position) ..... 76  
 Locks  
   Anti-theft Steering Column ..... 76  
   Fuel Fill Door ..... 181  
   Power Door ..... 78  
   Trunk ..... 88  
 Low Coolant Level..... 185  
 Low Fuel Indicator ..... 62  
 Low Oil Pressure Indicator .... 57, 263  
 Lower Anchors..... 41  
 Lower Gear, Downshifting to a.... 195  
 Lubricant Specifications Chart ... 278  
 Luggage, Storing (Cargo) ..... 188

CONTINUED

# Index

## M

Maintenance.....	207
Items .....	212, 215
Minder.....	209
Minder Indicator.....	60, 209
Owner's Maintenance	
Checks .....	214
Record.....	216-217
Safety.....	208
Malfunction Indicator Lamp ..	57, 264
Manual Transmission.....	195
Checking Fluid Level.....	229
Shifting.....	195
Manual Transmission Fluid .....	229
Mats, Floor .....	238
Meters, Gauges.....	63
Methanol in Gasoline .....	180
Mirrors, Adjusting .....	100
Modifying Your Vehicle.....	187
Moonroof .....	98
MP3 .....	127, 147, 156

## N

Neutral Gear Position.....	199
----------------------------	-----

New Vehicle Break-in .....	180
Normal Shift Speeds.....	196
NOTICE, Explanation of.....	i
Numbers, Identification.....	276

## O

Octane Requirement, Gasoline ....	180
Odometer.....	64
Odometer, Trip .....	64
Oil	
Change, How to .....	222
Change, When to .....	209
Checking Engine .....	183
Pressure Indicator .....	57, 263
Selecting Proper Viscosity	
Chart .....	221
ON (Ignition Key Position) .....	76
Onboard Refueling Vapor	
Recovery .....	283
Outside Mirrors .....	100
Overheating, Engine .....	261
Owner's Maintenance Checks .....	214
Oxygenated Fuels.....	180

## P

Panel Brightness Control .....	71
Park Gear Position.....	199
Parking.....	202
Parking Brake .....	101
Parking Brake and Brake	
System Indicator.....	58, 265
Parking Lights .....	70, 235
Parking Over Things that	
Burn.....	202, 285
PC Card.....	147
PGM-FI System.....	284
Playing a Disc.....	126, 146
Playing a PC Card.....	146
Pollen Filter .....	239
Power Door Locks.....	78
Power Socket Locations .....	102, 104
Power Steering Fluid.....	231
Power Windows .....	96
Pregnancy, Using Seat Belts .....	16
Preparing to Drive .....	193
Protecting Adults and Teens.....	11
Additional Safety Precautions....	16
Advice for Pregnant Women.....	16

Protecting Children .....	32
General Guideline .....	32
Installing a Child Seat .....	40
Protecting Infants .....	37
Protecting Larger Children .....	46
Protecting Small Children .....	38
Selecting a Child Seat .....	39
Using Child Seats with Tethers .....	45
Using LATCH .....	41

## R

Radiator Overheating .....	261
Radio/Disc Sound System .....	116
Radio/Disc/PC Card Sound System .....	134
Recommended Tire Pressures ....	242
Radio Theft Protection .....	172
Readiness Codes .....	264, 286
Rear Lights, Bulb Replacement .....	236
Rear Seat Access .....	92
Rear Seat, Folding .....	94
Rear View Mirror .....	100
Rear Window Defogger .....	72

Reclining the Seat-backs .....	90
Recommended Shift Speeds .....	196
Refueling .....	181
Reminder Indicators .....	55, 57
Remote Transmitter .....	85
Replacement Information	
Dust and Pollen Filter .....	239
Engine Oil and Filter .....	222
Fuses .....	266
Light Bulbs .....	232
Maintenance Minder .....	209
Spark Plugs .....	278
Tires and Wheels .....	246
Wiper Blades .....	239
Replacing Seat Belts After a Crash .....	20
Reporting Safety Defects* .....	290
Reserve Tank, Engine Coolant .....	185, 224
Restraint, Child .....	32
Reverse Gear Position .....	199
Reverse Lockout .....	197
Rotation, Tire .....	244

## S

Safety Belts .....	8, 18
Safety Defects, Reporting* .....	290
Safety Features .....	7
Airbags .....	9
Seat Belts .....	8
Safety Labels, Location of .....	51
Safety Messages .....	ii
Seat Belts .....	8, 18
Additional Information .....	18
Automatic Seat Belt Tensioners .....	19
Cleaning .....	237
Lap/Shoulder Belt .....	14, 19
Maintenance .....	20
Reminder Indicator and Beeper .....	18, 57
System Components .....	18
Use During Pregnancy .....	16
Wearing a Lap/Shoulder Belt .....	14, 19
Seats .....	90
Seats, Folding Rear .....	94

CONTINUED

# Index

- Security System ..... 174  
Selecting a Child Seat..... 39  
Serial Number ..... 276  
Service Intervals ..... 209  
Service Manual\* ..... 291  
Service Station Procedures ..... 181  
Setting the Clock ..... 173  
Shift Lever Position Indicators .... 198  
Shift Lock Release..... 201  
Side Airbags ..... 9, 26  
    Off Indicator..... 29, 58  
Side Curtain Airbags..... 9, 28  
Side Marker Lights, Bulb  
    Replacement..... 235  
Signaling Turns..... 70  
Snow Chains ..... 247  
Snow Tires..... 246  
Sockets, Accessory Power..... 104  
Sound System..... 115  
Spare Tire  
    Inflating..... 252  
    Specifications ..... 279  
Spark Plugs..... 278  
Specifications ..... 278  
Speed Control..... 175  
Speed Limiter..... 197, 200  
SRS, Additional Information..... 21  
    Additional Safety Precautions.... 31  
    Airbag Service..... 30  
    Airbag System Components..... 21  
    How the Passenger Airbag  
        Off Indicator Works ..... 29  
    How the Side Airbag Off  
        Indicator Works..... 29  
    How the SRS Indicator Works... 28  
    How Your Front Airbags  
        Work..... 23  
    How Your Side Airbags Work... 26  
    How Your Side Curtain Airbags  
        Work..... 28  
SRS Indicator..... 28, 58  
START (Ignition Key Position) .... 76  
Starting the Engine..... 194  
    In Cold Weather at High  
        Altitude ..... 194  
        With a Dead Battery ..... 259  
State Emissions Testing ..... 286  
Steam Coming from Engine..... 261  
Steering Wheel  
    Adjustments ..... 73  
    Anti-theft Column Lock ..... 76  
Steering Wheel Buttons..... 170, 175  
Stereo Sound System ..... 115  
Storing Your Vehicle ..... 250  
Supplemental Restraint  
    System..... 9, 21  
    Servicing ..... 30  
    SRS Indicator..... 28, 58  
    System Components..... 21  
SVC..... 120, 144  
Synthetic Oil..... 221
- T**
- Taillights, Changing Bulbs..... 236  
Taking Care of the Unexpected .. 251  
Technical Descriptions  
    DOT Tire Quality Grading\* .... 280  
    Emissions Control Systems..... 283  
    Oxygenated Fuels..... 180  
    Three Way Catalytic  
        Converter..... 284, 285  
Temperature Gauge ..... 66  
Tether Anchor Points..... 45  
Theft Protection, Radio..... 172  
Three Way Catalytic  
    Converter..... 284, 285  
Tilt the Steering Wheel..... 73

- Time, Setting the ..... 173
- Tire Chains ..... 247
- Tire, How to Change a Flat ..... 253
- Tires ..... 241
- Air Pressure ..... 242
  - Checking Wear ..... 243
  - Compact Spare ..... 252
  - DOT Tire Quality Grading ..... 280
  - Inflation ..... 241
  - Inspection ..... 243
  - Labeling ..... 282
  - Maintenance ..... 244
  - Replacing ..... 245
  - Rotating ..... 244
  - Snow ..... 246
  - Specifications ..... 279
- Tools, Tire Changing ..... 253
- Towing
- A Trailer ..... 205
  - Emergency Wrecker ..... 272
- Transmission
- Checking Fluid Level,
    - Automatic ..... 228
  - Checking Fluid Level,
    - Manual ..... 229
  - Fluid Selection ..... 228, 229
- Identification Number ..... 277
  - Shifting the Automatic ..... 198
  - Shifting the Manual ..... 195
  - Treadwear\* ..... 280
  - Treadwear Indicators ..... 243
  - Trip Meter ..... 64
  - Trunk ..... 88
    - Emergency Opener ..... 89
    - Opening ..... 88
    - Open Indicator ..... 61
  - Turn Signals ..... 70
- U**
- Unexpected, Taking Care
    - of the ..... 251
  - Uniform Tire Quality Grading\* ... 280
  - Unleaded Gasoline ..... 180
  - Used Oil, How to Dispose of ..... 224
  - Using a Booster Seat ..... 47
- V**
- Vanity Mirror ..... 105
  - Vehicle Capacity Load ..... 189
  - Vehicle Dimensions ..... 278
  - Vehicle Identification Number ..... 276
  - Vehicle Storage ..... 250
  - Ventilation ..... 112
  - VIN ..... 276
  - Viscosity, Oil ..... 221
- W**
- WARNING, Explanation of ..... ii
  - Warning Button, Hazard ..... 72
  - Warning Labels, Location of ..... 51
  - Warranty Coverages ..... 289
  - Washer, Windshield
    - Checking the Fluid Level ..... 227
    - Indicator ..... 61
    - Operation ..... 69
  - Wheels
    - Adjusting the Steering ..... 73
    - Alignment and Balance ..... 244
    - Compact Spare ..... 252
    - Replacing ..... 245
    - Wrench, Nut ..... 254
  - Windows
    - Operating the Power ..... 96
    - Rear, Defogger ..... 72

# Index

---

Windshield	
Cleaning.....	69
Defroster .....	114
Washers.....	69
Wipers, Windshield	
Changing Blades.....	239
Operation.....	69
WMA.....	127, 147, 156
Worn Tires .....	243
Wrecker, Emergency Towing.....	272

\* : U.S. only

# Service Information Summary

---

## **Gasoline:**

### **DX, Canadian DX-G, LX, EX:**

Unleaded gasoline, pump octane number of 87 or higher.

### **Si:**

Premium unleaded gasoline, pump octane number of 91 or higher.

## **Fuel Tank Capacity:**

13.2 US gal (50 ℓ)

## **Recommended Engine Oil:**

### **DX, Canadian DX-G, LX, EX:**

API Premium grade 5W-20 detergent oil (see page [221](#) ).

Oil change capacity (including filter):

3.9 US qt (3.7 ℓ)

### **Si:**

API Premium grade 5W-30 detergent oil (see page [221](#) ).

Oil change capacity (including filter):

4.6 US qt (4.4 ℓ)

## **Automatic Transmission Fluid:**

Honda ATF-Z1 (Automatic Transmission Fluid) preferred, or a DEXRON® III ATF as a temporary replacement (see page [228](#) ).

## **Manual Transmission Fluid:**

Honda Manual Transmission Fluid preferred, or an SAE 10W-30 or 10W-40 motor oil as a temporary replacement (see page [229](#) ).

Capacity (including differential):

DX, Canadian DX-G, LX, EX:

1.5 US qt (1.4 ℓ)

Si:

1.6 US qt (1.5 ℓ)

## **Power Steering Fluid:**

### **All models except Si:**

Honda Power Steering Fluid preferred, or another brand of power steering fluid as a temporary replacement. Do not

use ATF (see page [231](#) ).

## **Brake Fluid:**

Honda Heavy Duty Brake Fluid DOT 3 preferred, or a DOT 3 or DOT 4 brake fluid as a temporary replacement (see page [230](#) ).

## **Tire Pressure (measured cold):**

### **DX, Canadian DX-G**

Front/Rear:

30 psi (210 kPa , 2.1 kgf/cm<sup>2</sup>)

### **LX, EX**

Front/Rear:

32 psi (220 kPa , 2.2 kgf/cm<sup>2</sup>)

### **Si (with standard tires)**

Front:

32 psi (220 kPa , 2.2 kgf/cm<sup>2</sup>)

Rear:

29 psi (200 kPa , 2.0 kgf/cm<sup>2</sup>)

### **Si (with optional tires)**

Front/Rear:

32 psi (220 kPa , 2.2 kgf/cm<sup>2</sup>)

Spare Tire:

60 psi (420 kPa , 4.2 kgf/cm<sup>2</sup>)