

2006 CR-V Online Reference Owner's Manual

Use these links (and links throughout this manual) to navigate through this reference.
For a printed owner's manual, click on authorized manuals or go to www.helminc.com.

Contents

Owner's Identification Form

Introduction	i
A Few Words About Safety	ii
Important Handling Information	iii
Your Vehicle at a Glance	3
Driver and Passenger Safety	5
Proper use and care of your vehicle's seat belts, and Supplemental Restraint System.	
Instruments and Controls	53
Instrument panel indicator and gauge, and how to use dashboard and steering column controls.	
Comfort and Convenience Features	97
How to operate the climate control system, the audio system, and other convenience features.	
Before Driving	141
What gasoline to use, how to break-in your new vehicle, and how to load luggage and other cargo.	
Driving	155
The proper way to start the engine, shift the transmission, and park, plus towing a trailer.	
Maintenance	183
The Maintenance Schedule shows you when you need to take your vehicle to the dealer.	
Taking Care of the Unexpected	219
This section covers several problems motorists sometimes experience, and how to handle them.	
Technical Information	243
ID numbers, dimensions, capacities, and technical information.	
Warranty and Customer Relations (U.S. and Canada)	255
A summary of the warranties covering your new Acura, and how to contact us.	
Authorized Manuals (U.S. only)	259
How to order manuals and other technical literature.	
Index	I

Service Information Summary

A summary of information you need when you pull up to the fuel pump.

Congratulations! Your selection of a 2006 Honda CR-V was a wise investment. It will give you years of driving pleasure.

One of the best ways to enhance the enjoyment of your new vehicle is to read this manual. In it, you will learn how to operate its driving controls and convenience items. Afterwards, keep this owner's manual in your vehicle so you can refer to it at any time.

Several warranties protect your new vehicle. Read the warranty booklet thoroughly so you understand the coverages and are aware of your rights and responsibilities.

Maintaining your vehicle according to the schedules given in this manual helps to keep your driving trouble-free while it preserves your investment. When your vehicle needs maintenance, keep in mind that your dealer's staff is specially trained in servicing the many systems unique to your vehicle. Your dealer is dedicated to your satisfaction and will be pleased to answer any questions and concerns.

As you read this manual, you will find information that is preceded by a **NOTICE** symbol. This information is intended to help you avoid damage to your vehicle, other property, or the environment.

California Proposition 65 Warning

WARNING: This product contains or emits chemicals known to the state of California to cause cancer and birth defects or other reproductive harm.

Event Data Recorders

This vehicle is equipped with one or more recording devices commonly referred to as event data recorders or sensing and diagnostic modules.

A Few Words About Safety

Your safety, and the safety of others, is very important. And operating this vehicle safely is an important responsibility.

To help you make informed decisions about safety, we have provided operating procedures and other information on labels and in this manual. This information alerts you to potential hazards that could hurt you or others.

Of course, it is not practical or possible to warn you about all the hazards associated with operating or maintaining your vehicle. You must use your own good judgement.

You will find this important safety information in a variety of forms, including:

- **Safety Labels** — on the vehicle.
- **Safety Messages** — preceded by a safety alert symbol  and one of three signal words: **DANGER**, **WARNING**, or **CAUTION**.
These signal words mean:

 **DANGER**

You **WILL** be **KILLED** or **SERIOUSLY HURT** if you don't follow instructions.

 **WARNING**

You **CAN** be **KILLED** or **SERIOUSLY HURT** if you don't follow instructions.

 **CAUTION**

You **CAN** be **HURT** if you don't follow instructions.

- **Safety Headings** — such as Important Safety Reminders or Important Safety Precautions.
- **Safety Section** — such as Driver and Passenger Safety.
- **Instructions** — how to use this vehicle correctly and safely.

This entire book is filled with important safety information — please read it carefully.

Your CR-V has higher ground clearance than a passenger vehicle designed for use only on pavement. Higher ground clearance has many advantages for off-highway driving. It allows you to travel over bumps, obstacles, and rough terrain. It also provides good visibility so you can anticipate problems earlier.

These advantages come at some cost. Because your vehicle is taller and rides higher off the ground, it has a high center of gravity. This means your vehicle can tip or roll over if you make abrupt turns. Utility vehicles have a significantly higher rollover rate than other types of vehicles. In a rollover crash, an unbelted person is significantly more likely to die than a person wearing a seat belt. As a reminder, make sure you and your passengers always wear seat belts.

For information on how to reduce the risk of rollover, read “Driving Guidelines” on page 156 of this manual and the *Off-Highway Driving Guidelines* section on page 179 . Failure to operate your vehicle correctly might result in loss of control or an accident.

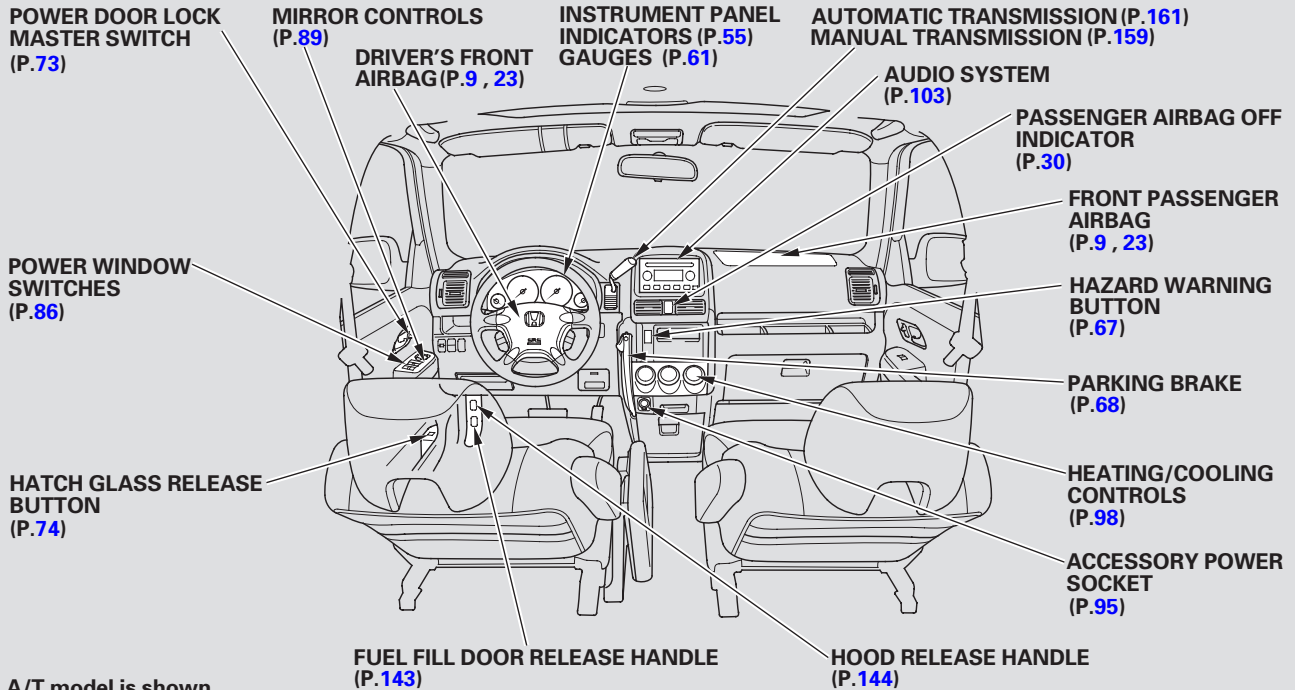

A/T model is shown.

Your Vehicle at a Glance

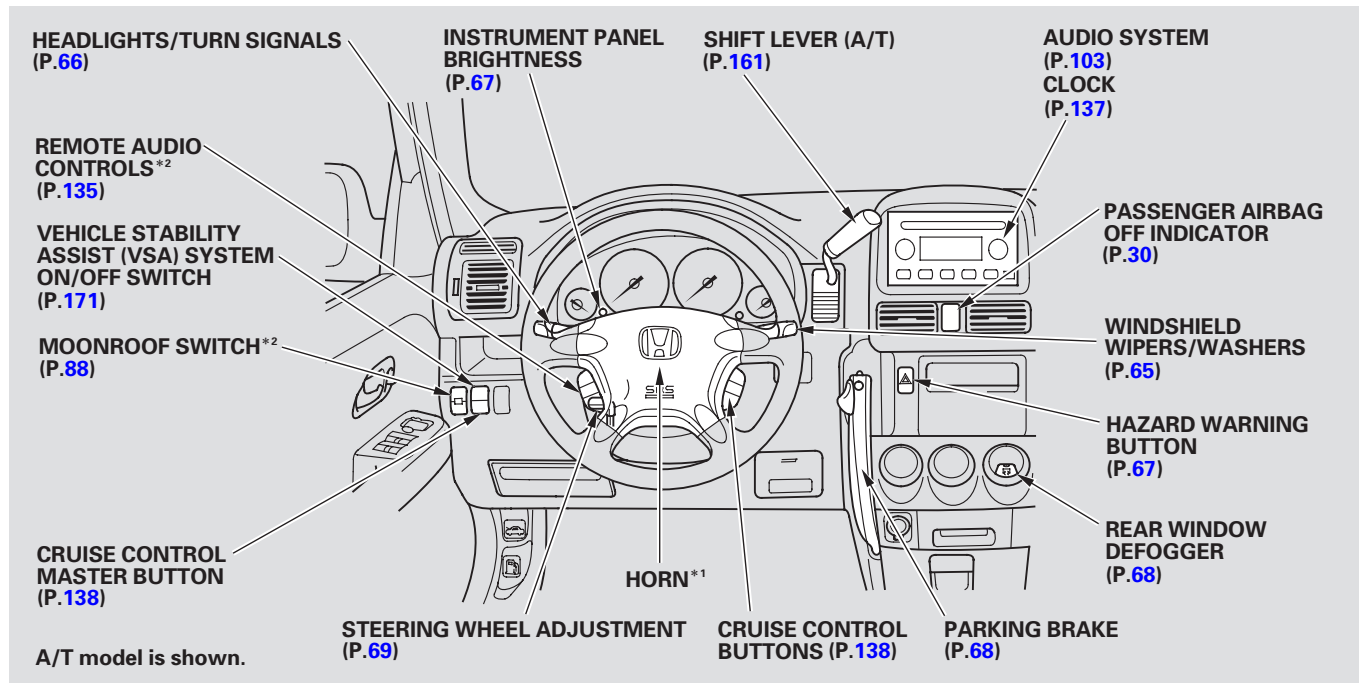

* 1 : To use the horn, press the center pad of the steering wheel.

* 2 : If equipped.

This section gives you important information about how to protect yourself and your passengers. It shows you how to use seat belts. It explains how your airbags work. And it tells you how to properly restrain infants and children in your vehicle.

Important Safety Precautions	6
Your Vehicle's Safety Features.....	7
Protecting Adults and Teens.....	11
1. Close and Lock the Doors	11
2. Adjust the Front Seats	11
3. Adjust the Seat-Backs	12
4. Adjust the Head Restraints	13
5. Fasten and Position the Seat Belts.....	14
6. Maintain a Proper Sitting Position	15
Advice for Pregnant Women.....	16
Additional Safety Precautions....	17

Additional Information About Your Seat Belts	18
Seat Belt System Components... ..	18
Lap/Shoulder Belt.....	18
Automatic Seat Belt Tensioners.....	19
Seat Belt Maintenance	20
Additional Information About Your Airbags	21
Airbag System Components.....	21
How Your Front Airbags Work.....	23
How Your Side Airbags Work....	26
How Your Side Curtain Airbags Work.....	28
How the SRS Indicator Works... ..	29
How the Side Airbag Off Indicator Works	29
How the Passenger Airbag Off Indicator Works	30
Airbag Service	30
Additional Safety Precautions....	31
Protecting Children – General Guidelines.....	32
All Children Must Be Restrained	32

All Children Should Sit in a Back Seat	33
The Passenger's Front Airbag Can Pose Serious Risks	33
If You Must Drive with Several Children	35
If a Child Requires Close Attention	35
Additional Safety Precautions....	35
Protecting Infants and Small Children	37
Protecting Infants.....	37
Protecting Small Children	38
Selecting a Child Seat.....	39
Installing a Child Seat	40
With LATCH	41
With a Lap/Shoulder Belt	43
With a Tether	45
Protecting Larger Children	46
Checking Seat Belt Fit	47
Using a Booster Seat	47
When Can a Larger Child Sit in Front.....	48
Additional Safety Precautions....	49
Carbon Monoxide Hazard	50
Safety Labels	51

Important Safety Precautions

You'll find many safety recommendations throughout this section, and throughout this manual. The recommendations on this page are the ones we consider to be the most important.

Always Wear Your Seat Belt

A seat belt is your best protection in all types of collisions. Airbags are designed to supplement seat belts, not replace them. So even though your vehicle is equipped with airbags, make sure you and your passengers always wear your seat belts, and wear them properly (see page 14).

Restrain All Children

Children age 12 and under should ride properly restrained in a back seat, not the front seat. Infants and small children should be restrained in a child seat. Larger children should use a booster seat and a lap/shoulder belt until they can use the belt properly without a booster seat (see pages 32 – 49).

Be Aware of Airbag Hazards

While airbags can save lives, they can cause serious or fatal injuries to occupants who sit too close to them, or are not properly restrained. Infants, young children, and short adults are at the greatest risk. Be sure to follow all instructions and warnings in this manual.

Don't Drink and Drive

Alcohol and driving don't mix. Even one drink can reduce your ability to respond to changing conditions, and your reaction time gets worse with

every additional drink. So don't drink and drive, and don't let your friends drink and drive, either.

Control Your Speed

Excessive speed is a major factor in crash injuries and deaths. Generally, the higher the speed, the greater the risk, but serious injuries can also occur at lower speeds. Never drive faster than is safe for current conditions, regardless of the maximum speed posted.

Keep Your Vehicle in Safe Condition

Having a tire blowout or a mechanical failure can be extremely hazardous. To reduce the possibility of such problems, check your tire pressures and condition frequently, and perform all regularly scheduled maintenance (see page 187).

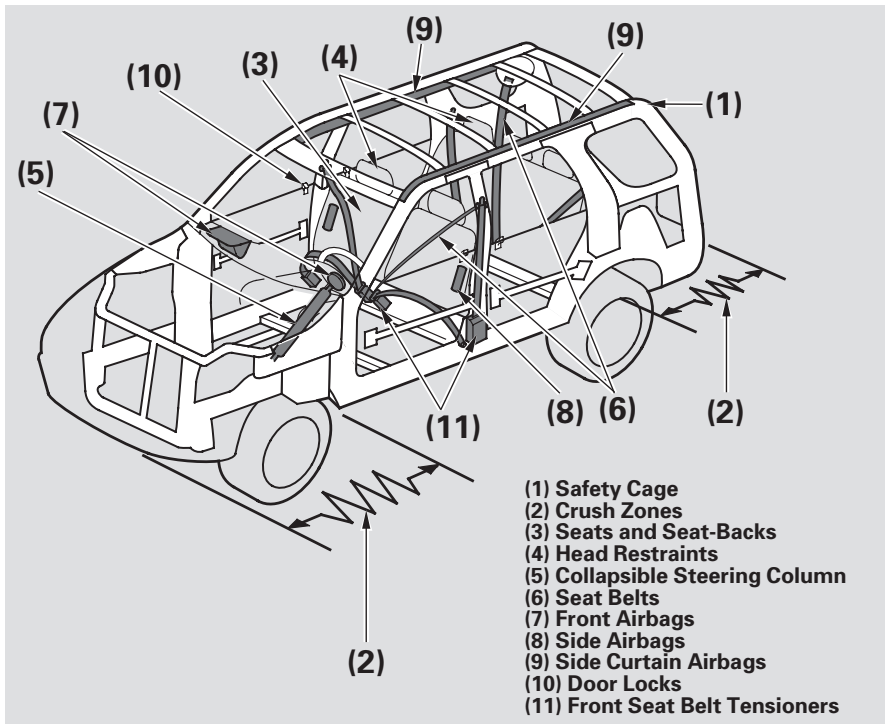

Your vehicle is equipped with many features that work together to protect you and your passengers during a crash.

Some features do not require any action on your part. These include a strong steel framework that forms a safety cage around the passenger compartment, front and rear crush zones, a collapsible steering column, and tensioners that tighten the front seat belts in a crash.

However, you and your passengers can't take full advantage of these features unless you remain sitting in a proper position and ***always wear your seat belts***. In fact, some safety features can contribute to injuries if they are not used properly.

The following pages explain how you can take an active role in protecting yourself and your passengers.

Your Vehicle's Safety Features

Seat Belts

Your vehicle is equipped with seat belts in all seating positions.

Your seat belt system also includes an indicator on the instrument panel and a beeper to remind you and your passengers to fasten your seat belts.

Why Wear Seat Belts

Seat belts are the single most effective safety device for adults and larger children. (Infants and smaller children must be properly restrained in child seats.)

Not wearing a seat belt properly increases the chance of serious injury or death in a crash, even though your vehicle has airbags.

In addition, most states and all Canadian provinces require you to wear seat belts.

WARNING

Not wearing a seat belt properly increases the chance of serious injury or death in a crash, even though your vehicle has airbags.

Be sure you and your passengers always wear seat belts and wear them properly.

When properly worn, seat belts:

- Keep you connected to the vehicle so you can take advantage of the vehicle's built-in safety features.
- Help protect you in almost every type of crash, including frontal, side, and rear impacts and rollovers.

- Help keep you from being thrown against the inside of the vehicle and against other occupants.
- Keep you from being thrown out of the vehicle.
- Help keep you in a good position should the airbags ever deploy. A good position reduces the risk of injury from an inflating airbag and allows you to get the best advantage from the airbag.

Of course, seat belts cannot completely protect you in every crash. But in most cases, seat belts can reduce your risk of serious injury.

What You Should Do:

Always wear your seat belt, and make sure you wear it properly.

Airbags

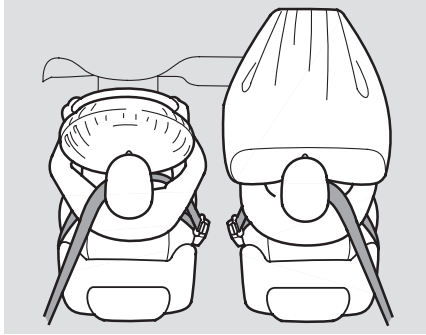

Your vehicle has a supplemental restraint system (SRS) with front airbags to help protect the heads and chests of the driver and a front seat passenger during a moderate to severe frontal collision (see page [23](#) for more information on how your front airbags work).

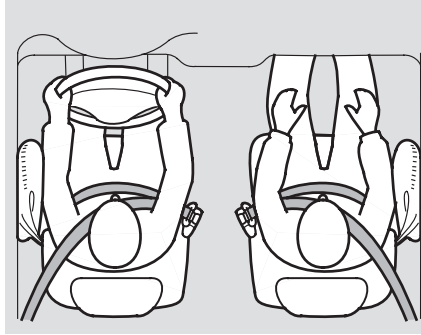

Your vehicle has side airbags to help protect the upper torso of the driver or a front seat passenger during a moderate to severe side impact (see page [26](#) for more information on how your side airbags work).

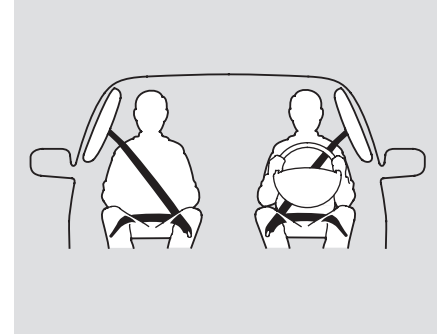

Your vehicle also has side curtain airbags to help protect the heads of the driver, front passenger, and passengers in the outer rear seating positions during a moderate to severe side impact (see page [28](#) for more information on how your side curtain airbags work).

CONTINUED

Your Vehicle's Safety Features

The most important things you need to know about your airbags are:

- ***Airbags do not replace seat belts.*** They are designed to supplement the seat belts.
- ***Airbags offer no protection in rear impacts, or minor frontal or side collisions.***
- ***Airbags can pose hazards.*** To do their job, airbags must inflate with tremendous force. So while airbags help save lives, they can cause minor injuries or more serious or even fatal injuries if occupants are not properly restrained or sitting properly.

What you should do: Always wear your seat belt properly, and sit upright and as far back from the steering wheel as possible while allowing full control of the vehicle. A front passenger should move their seat as far back from the dashboard as possible.

The rest of this section gives more detailed information about how you can maximize your safety.

Remember, however, that no safety system can prevent all injuries or deaths that can occur in a severe crash, even when seat belts are properly worn and the airbags deploy.

Introduction

The following pages provide instructions on how to properly protect the driver, adult passengers, and teenage children who are large enough and mature enough to drive or ride in the front.

See pages [32](#) – [49](#) for important guidelines on how to properly protect infants, small children, and larger children who ride in your vehicle.

1. Close and Lock the Doors

After everyone has entered the vehicle, be sure the doors are closed and locked.

Locking the doors reduces the chance of someone being thrown out of the vehicle during a crash, and it helps prevent passengers from accidentally opening a door and falling out.

Locking the doors also helps prevent an outsider from unexpectedly opening a door when you come to a stop.

See page [73](#) for how to lock the doors.

2. Adjust the Front Seats

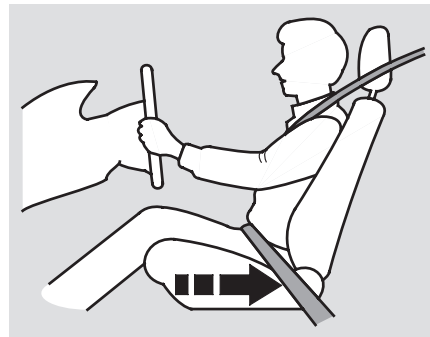

Adjust the driver's seat as far to the rear as possible while allowing you to maintain full control of the vehicle. Have a front passenger adjust their seat as far to the rear as possible.

CONTINUED

Protecting Adults and Teens

If you sit too close to the steering wheel or dashboard, you can be seriously injured by an inflating front airbag, or by striking the steering wheel or dashboard.

The National Highway Traffic Safety Administration and Transport Canada recommend that drivers allow at least 10 inches (25 cm) between the center of the steering wheel and the chest. In addition to adjusting the seat, you can adjust the steering wheel up and down (see page 69).

If you cannot get far enough away from the steering wheel and still reach the controls, we recommend that you investigate whether some type of adaptive equipment may help.

⚠ WARNING

Sitting too close to a front airbag can result in serious injury or death if the front airbags inflate.

Always sit as far back from the front airbags as possible.

Once your seat is adjusted correctly, rock it back and forth to make sure the seat is locked in position.

See page 78 for how to adjust the front seats.

3. Adjust the Seat-Backs

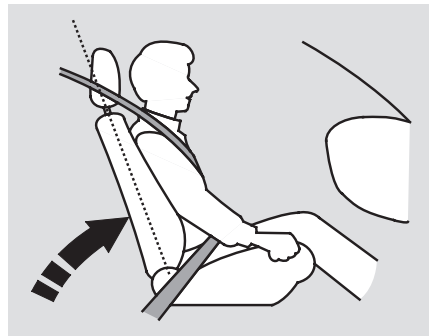

Adjust the driver's seat-back to a comfortable, upright position, leaving ample space between your chest and the airbag cover in the center of the steering wheel.

Passengers with adjustable seat-backs should also adjust their seat-back to a comfortable, upright position.

⚠️ WARNING

Reclining the seat-back too far can result in serious injury or death in a crash.

Adjust the seat-back to an upright position, and sit well back in the seat.

Reclining a seat-back so that the shoulder part of the belt no longer rests against the occupant's chest reduces the protective capability of the belt. It also increases the chance of sliding under the belt in a crash and being seriously injured. The farther a seat-back is reclined, the greater the risk of injury.

See page [78](#) for how to adjust the seat-backs.

4. Adjust the Head Restraints

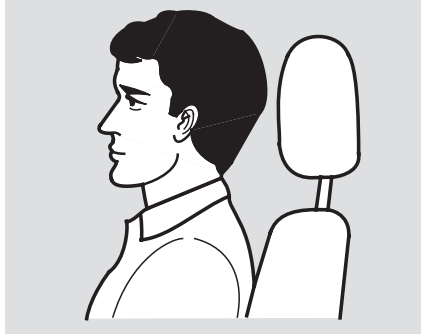

Adjust the driver's head restraint so the back of your head rests against the center of the restraint.

Have passengers with adjustable head restraints adjust their restraints properly as well. Taller persons should adjust their restraint as high as possible.

⚠️ WARNING

Improperly positioning head restraints reduces their effectiveness and you can be seriously injured in a crash.

Make sure head restraints are in place and positioned properly before driving.

Properly adjusted head restraints will help protect occupants from whiplash and other crash injuries.

See page [80](#) for how to adjust the head restraints.

Protecting Adults and Teens

5. Fasten and Position the Seat Belts

Insert the latch plate into the buckle, then tug on the belt to make sure the belt is securely latched. Check that the belt is not twisted, because a twisted belt can cause serious injuries in a crash.

The seat belt in the center position of the back seat can be unlatched and retracted to allow the back seat to be folded up or down. See page [85](#) for how to unlatch and relatch the seat belt.



Position the lap part of the belt as low as possible across your hips, then pull up on the shoulder part of the belt so the lap part fits snugly. This lets your strong pelvic bones take the force of a crash and reduces the chance of internal injuries.

If necessary, pull up on the belt again to remove any slack, then check that the belt rests across the center of your chest and over your shoulder.

This spreads the forces of a crash over the strongest bones in your upper body.

⚠ WARNING

Improperly positioning the seat belts can cause serious injury or death in a crash.

Make sure all seat belts are properly positioned before driving.

If the seat belt touches or crosses your neck, or if it crosses your arm instead of your shoulder, you need to adjust the seat belt anchor height.

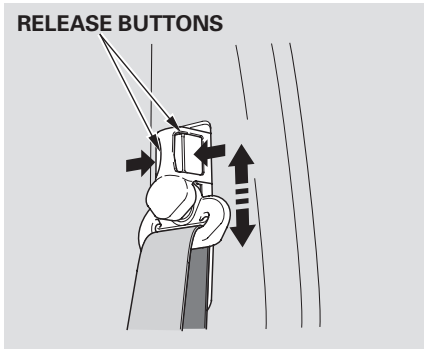

The front seats have adjustable seat belt anchors. To adjust the height of an anchor, press and hold the release buttons, and slide the anchor up or down as needed (it has four positions).

Never place the shoulder portion of a lap/shoulder belt under your arm or behind your back. This could cause very serious injuries in a crash.

If a seat belt does not seem to work properly, it may not protect the occupant in a crash.

No one should sit in a seat with an inoperative seat belt. Using a seat belt that is not working properly can result in serious injury or death. Have your dealer check the belt as soon as possible.

See page 18 for additional information about your seat belts and how to take care of them.

6. Maintain a Proper Sitting Position

After all occupants have adjusted their seats and put on seat belts, it is very important that they continue to sit upright, well back in their seats, with their feet on the floor, until the vehicle is parked and the engine is off.

Sitting improperly can increase the chance of injury during a crash. For example, if an occupant slouches, lies down, turns sideways, sits forward, leans forward or sideways, or puts one or both feet up, the chance of injury during a crash is greatly increased.

CONTINUED

Protecting Adults and Teens

In addition, an occupant who is out of position in the front seat can be seriously or fatally injured in a crash by striking interior parts of the vehicle or being struck by an inflating front airbag.

⚠ WARNING

Sitting improperly or out of position can result in serious injury or death in a crash.

Always sit upright, well back in the seat, with your feet on the floor.

Advice for Pregnant Women



If you are pregnant, the best way to protect yourself and your unborn child when driving or riding in a vehicle is to always wear a seat belt, and keep the lap part of the belt as low as possible across the hips.

When driving, remember to sit upright and adjust the seat as far back as possible while allowing full control of the vehicle. When riding as a front passenger, adjust the seat as far back as possible.

This will reduce the risk of injuries to both you and your unborn child that can be caused by a crash or an inflating front airbag.

Each time you have a checkup, ask your doctor if it's okay for you to drive.

Additional Safety Precautions

- **Never let passengers ride in the cargo area or on top of a folded-down back seat.** If they do, they could be very seriously injured in a crash.
- **Passengers should not stand up or change seats while the vehicle is moving.** A passenger who is not wearing a seat belt during a crash or emergency stop can be thrown against the inside of the vehicle, against other occupants, or out of the vehicle.
- **Two people should never use the same seat belt.** If they do, they could be very seriously injured in a crash.
- **Do not put any accessories on seat belts.** Devices intended to improve occupant comfort or reposition the shoulder part of a seat belt can reduce the protective capability of the belt and increase the chance of serious injury in a crash.
- **Do not place hard or sharp objects between yourself and a front airbag.** Carrying hard or sharp objects on your lap, or driving with a pipe or other sharp object in your mouth, can result in injuries if your front airbag inflates.
- **Keep your hands and arms away from the airbag covers.** If your hands or arms are close to an airbag cover, they could be injured if the airbag inflates.
- **Do not attach or place objects on the front airbag covers.** Objects on the covers marked “SRS AIRBAG” could interfere with the proper operation of the airbags or be propelled inside the vehicle and hurt someone if the airbags inflate.
- **Do not attach solid objects on or near a door.** If a side airbag or a side curtain airbag inflates, a cup holder or other solid object attached on or near the door could be propelled inside the vehicle and hurt someone.

Additional Information About Your Seat Belts

Seat Belt System Components

Your seat belt system includes lap/shoulder belts in all five seating positions. The front seat belts are also equipped with automatic seat belt tensioners.



The seat belt system includes an indicator on the instrument panel and a beeper to remind you to fasten your seat belt.

If you turn the ignition switch to the ON (II) position before fastening your seat belt, the beeper will sound, and the indicator will flash.

If you do not fasten your seat belt before the beeper stops, the indicator will stop flashing but remain on.

If you continue driving without fastening your seat belt, the beeper will sound and the indicator will flash again at regular intervals.

Lap/Shoulder Belt

The lap/shoulder belt goes over your shoulder, across your chest, and across your hips.

To fasten the belt, insert the latch plate into the buckle, then tug on the belt to make sure the buckle is latched (see page 14 for how to properly position the belt).

To unlock the belt, press the red PRESS button on the buckle. Guide the belt across your body so that it retracts completely. After exiting the vehicle, be sure the belt is out of the way and will not get closed in the door.

All seat belts have an emergency locking retractor. In normal driving, the retractor lets you move freely in your seat while it keeps some tension on the belt. During a collision or sudden stop, the retractor automatically locks the belt to help restrain your body.

The seat belts in all positions except the driver's have an additional locking mechanism that must be activated to secure a child seat (see page 43).

If the shoulder part of the belt is pulled all the way out, the locking mechanism will activate. The belt will retract, but it will not allow the passenger to move freely.

To deactivate the locking mechanism, unlatch the buckle and let the seat belt fully retract. To refasten the seat belt, pull it out only as far as needed.

DETACHABLE ANCHOR

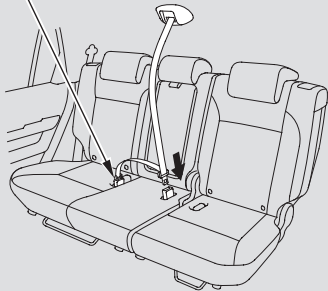

The lap/shoulder belt in the center seating position on the rear seat is equipped with a detachable anchor that has two parts: a small latch plate and an anchor buckle.

The detachable anchor should normally be latched whenever the seat-backs are in an upright position. For more information about the detachable anchors (see page 85).

Automatic Seat Belt Tensioners



For added protection, the front seat belts are equipped with automatic seat belt tensioners. When activated, the tensioners immediately tighten the belts to help hold the driver and a front passenger in place.

The tensioners are designed to activate in any collision severe enough to cause the front airbags to deploy, or if a sensor detects your vehicle is about to rollover (see page 28).

If a side curtain airbag deploys during a side impact, the tensioner on that side of the vehicle will also deploy.

The tensioners can also be activated during a collision in which the front airbags *do not deploy*. In this case, the airbags would not be needed, but the additional restraint could be helpful.

When the tensioners are activated, the seat belts will remain tight until they are unbuckled in the normal manner.

Additional Information About Your Seat Belts

Seat Belt Maintenance

For safety, you should check the condition of your seat belts regularly.

Pull each belt out fully, and look for frays, cuts, burns, and wear. Check that the latches work smoothly and the belts retract easily. If a belt does not retract easily, cleaning the belt may correct the problem (see page 208). Any belt that is not in good condition or working properly will not provide good protection and should be replaced as soon as possible.

Honda provides a lifetime warranty on seat belts for U.S. models. See your *Honda Warranty Information* booklet for details.

If a seat belt is worn during a crash, it must be replaced by your dealer. A belt that has been worn during a crash may not provide the same level of protection in a subsequent crash.

The dealer should also inspect the anchors for damage and replace them if needed. If the automatic seat belt tensioners activate during a crash, they must be replaced.

WARNING

Not checking or maintaining seat belts can result in serious injury or death if the seat belts do not work properly when needed.

Check your seat belts regularly, and have any problem corrected as soon as possible.

Airbag System Components

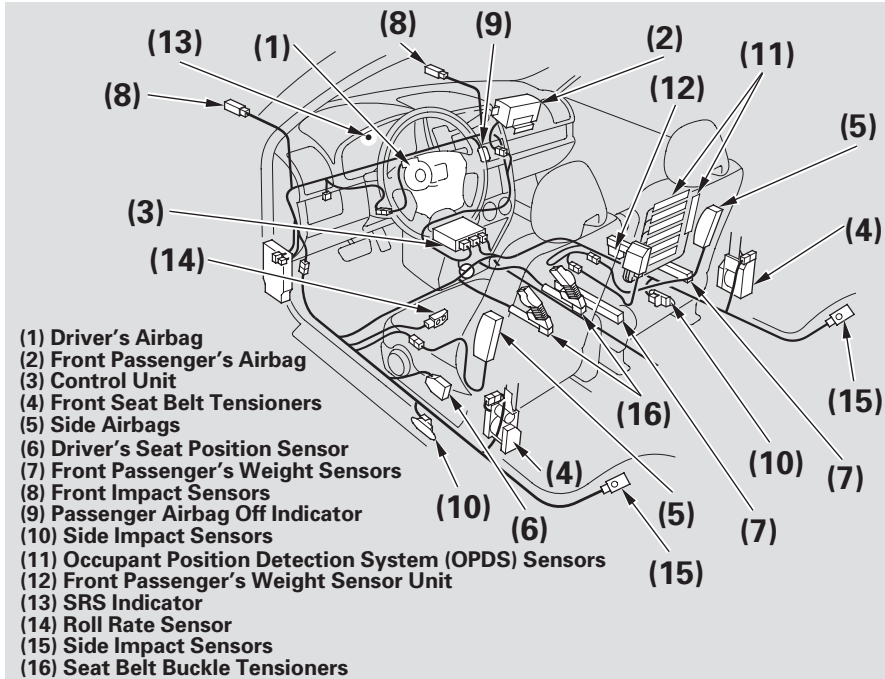

Your airbag system includes:

- Two SRS (supplemental restraint system) front airbags. The driver's airbag is stored in the center of the steering wheel; the front passenger's airbag is stored in the dashboard. Both are marked "SRS AIRBAG" (see page 23).
- Two side airbags, one for the driver and one for a front passenger. The airbags are stored in the outer edges of the seat-backs. Both are marked "SIDE AIRBAG" (see page 26).
- Two side curtain airbags, one for each side of the vehicle. The airbags are stored in the ceiling, above the side windows. The front and rear pillars are marked "SIDE CURTAIN AIRBAG" (see page 28).

CONTINUED

Additional Information About Your Airbags

- Automatic front seat belt tensioners (see page 19).
- Sensors that can detect a moderate to severe front impact or side impact.
- Sensors that can detect whether a child is in the passenger's side airbag path and automatically turn the airbag off (see page 27).
- A driver's seat position sensor that monitors the distance of the seat from the front airbag. If the seat is too far forward, the airbag will inflate with less force (see page 25).
- Weight sensors that monitor the weight on the front passenger's seat. These automatically turn off the passenger's front airbag if they detect an infant or small child may be in the seat (see page 25).
- A sophisticated electronic system that continually monitors and records information about the sensors, the control unit, the airbag activators, the seat belt tensioners, and driver and front passenger seat belt use when the ignition switch is in the ON (II) position.
- An indicator on the instrument panel that alerts you to a possible problem with your airbags, sensors, or seat belt tensioners (see page 29).
- A rollover sensor that monitors the degree and rate your vehicle may roll over and automatically deploy the side curtain airbags and activate the front seat belt tensioners if needed (see page 19).
- An indicator on the instrument panel that alerts you that the passenger's side airbag has been turned off (see page 29).
- An indicator on the dashboard that alerts you that the passenger's front airbag has been turned off (see page 30).
- Emergency backup power in case your vehicle's electrical system is disconnected in a crash.

How Your Front Airbags Work

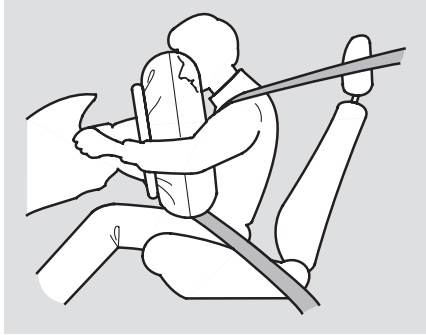

If you ever have a moderate to severe frontal collision, sensors will detect the vehicle's rapid deceleration.

If the rate of deceleration is high enough, the control unit will instantly inflate the driver's and front passenger's airbags, at the time and with the force needed.

During a frontal crash, your seat belt restrains your lower body and torso, and the front airbag helps protect your head and chest.

Although both airbags normally inflate within split second of each other, it is possible for only one airbag to deploy.

This can happen if the severity of a collision is at the margin, or threshold, that determines whether or not the airbags will deploy. In such cases, the seat belt will provide sufficient protection, and the supplemental protection offered by the airbag would be minimal.

Only the driver's airbag can deploy if there is no passenger in the front seat, or if the advanced airbag system has turned the passenger's airbag off (see page [25](#)).

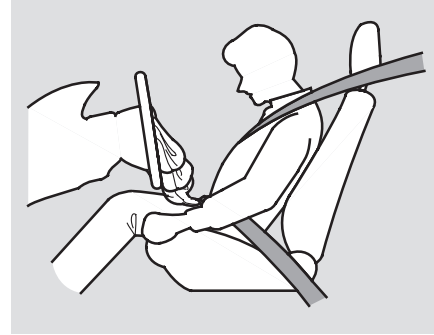

After inflating, the front airbags immediately deflate, so they won't interfere with the driver's visibility, or the ability to steer or operate other controls.

The total time for inflation and deflation is one-tenth of a second, so fast that most occupants are not aware that the airbags deployed until they see them lying in their laps.

CONTINUED

Additional Information About Your Airbags

After a crash, you may see what looks like smoke. This is actually powder from the airbag's surface. Although the powder is not harmful, people with respiratory problems may experience some temporary discomfort. If this occurs, get out of the vehicle as soon as it is safe to do so.

Dual-Stage Airbags

Your front airbags are dual-stage airbags. This means they have two inflation stages that can be ignited sequentially or simultaneously, depending on crash severity.

In a **more severe** crash, both stages will ignite simultaneously to provide the quickest and greatest protection.

In a **less severe** crash, one stage will ignite first, then the second stage will ignite a split second later. This provides longer airbag inflation time with a little less force.

Dual-Threshold Airbags

Your front airbags are also dual-threshold airbags. Airbags with this feature have two deployment thresholds that depend on whether or not the occupant is wearing a seat belt.

If the occupant's belt is **not latched**, the airbag will deploy at a slightly lower threshold, because the occupant would need extra protection.

If the occupant's belt **is latched**, the airbag will inflate at a slightly higher threshold, when the airbag would be needed to supplement the protection provided by the seat belt.

Advanced Airbags

Your front airbags are also advanced airbags. The main purpose of this feature is to help prevent airbag-caused injuries to short drivers and children who ride in front.

For both advanced airbags to work properly:

- Occupants must sit upright and wear their seat belts properly.
- Do not spill any liquids on or under the seats, cover the sensors, or put any cargo or metal objects under the front seats.
- Back-seat passengers should not put their feet under the front seats.

Failure to follow these instructions could damage the sensors or prevent them from working properly.

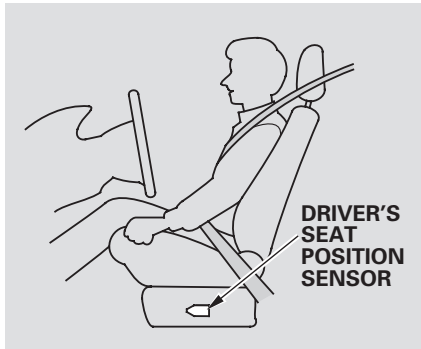

The driver's advanced front airbag system includes a seat position sensor under the seat. If the seat is too far forward, the airbag will inflate with less force, regardless of the severity of the impact.

If there is a problem with the sensor, the SRS Indicator will come on, and the airbag will inflate in the normal manner regardless of the driver's seating position.

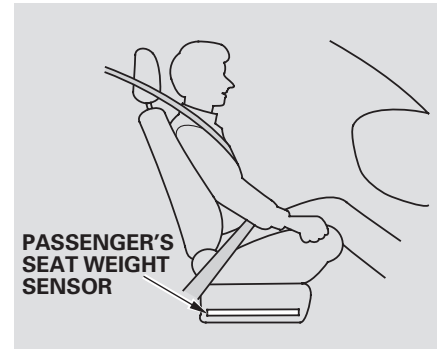

The passenger's advanced front airbag system has weight sensors under the seat. Although Honda does not encourage carrying an infant or small child in the front, if the sensors detect the weight of an infant or small child, the system will automatically turn the passenger's front airbag off.

CONTINUED

Additional Information About Your Airbags

When the airbag is turned off, an indicator in the center of the dashboard will come on indicating passenger airbag “OFF” (see page 30).

If the weight sensors detect there is no passenger in the front seat, the airbag will be off. However, the passenger airbag off indicator will not come on.

To ensure that the passenger’s advanced front airbag system will work properly, **do not do anything that would increase or decrease the weight on the front passenger’s seat.** This includes:

- A rear passenger pushing or pulling on the back of the passenger’s seat.

- Moving the front seat forcibly back against cargo on the seat or floor behind it.
- Hanging heavy items on the front passenger seat, or placing heavy items in the seat-back pocket.

Also, make sure the floor mat behind the front passenger’s seat is hooked to the floor mat anchor (see page 208). If it is not, the mat may interfere with the proper operation of the sensors and operation of the seat.

How Your Side Airbags Work

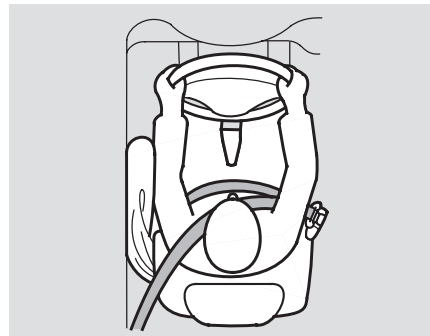

If you ever have a moderate to severe side impact, sensors will detect rapid deceleration and signal the control unit to instantly inflate either the driver’s or the passenger’s side airbag.

Only one airbag will deploy during a side impact. If the impact is on the passenger's side, the passenger's side airbag will deploy even if there is no passenger.

To get the best protection from the side airbags, front seat occupants should wear their seat belts and sit upright and well back in their seats.

Side Airbag Cutoff System

To reduce the risk of injury from an inflating side airbag, your vehicle has an automatic cutoff system for the passenger's side airbag.

Although Honda does not encourage children to ride in front, this system is designed to shut off the side airbag if a child leans into the side airbag's path.

The side airbag may also shut off if a short adult leans sideways, or a larger adult slouches and leans sideways into the airbag's deployment path.

Objects placed on the front passenger seat can also cause the side airbag to be shut off.

If the side airbag off indicator comes on (see page 29), have the passenger sit upright. Once the passenger is out of the airbag's deployment path, the system will turn the airbag back on, and the indicator will go out.

There will be some delay between the moment the passenger moves into or out of the airbag deployment path and when the indicator comes on or goes off.

A front seat passenger should not use a cushion or other object as a backrest. It may prevent the cutoff system from working properly.

Additional Information About Your Airbags

How Your Side Curtain Airbags Work

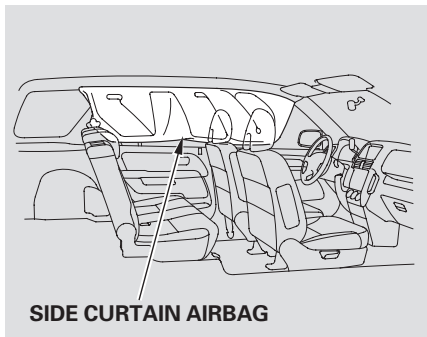

In a Side Impact

In a moderate to severe side impact, sensors will detect rapid acceleration and signal the control unit to instantly inflate the side curtain airbag and activate the seat belt tensioner on the driver's or the passenger's side of the vehicle.

If the impact is on the passenger's side, the passenger's side curtain airbag will inflate even if there are no occupants on that side of the vehicle.

In a Rollover

A rollover sensor monitors the degree and rate your vehicle may roll over and automatically deploy the side curtain airbags and activate the front seat belt tensioners (see page [19](#)).

In a rollover toward the front passenger's side of the vehicle, both side curtain airbags will inflate and the front seat belt tensioners will activate even if there are no occupants on that side of the vehicle.

To get the best protection from the side curtain airbags, occupants should wear their seat belts and sit upright and well back in their seats.

How the SRS Indicator Works



The SRS indicator alerts you to a potential problem with your airbags or seat belt tensioners.

When you turn the ignition switch to the ON (II) position, this indicator comes on briefly then goes off. This tells you the system is working properly.

If the indicator comes on at any other time, or does not come on at all, you should have the system checked by your dealer. For example:

- If the SRS indicator does not come on after you turn the ignition switch to the ON (II) position.
- If the indicator stays on after the engine starts.
- If the indicator comes on or flashes on and off while you drive.

If you see any of these indications, the airbags and seat belt tensioners may not work properly when you need them.

⚠ WARNING

Ignoring the SRS indicator can result in serious injury or death if the airbag systems or tensioners do not work properly.

Have your vehicle checked by a dealer as soon as possible if the SRS indicator alerts you to a possible problem.

How the Side Airbag Off Indicator Works

U.S.



Canada



This indicator alerts you that the passenger's side airbag has been shut off because weight sensors detect the weight of an infant or small child on the front passenger's seat. It does **not** mean there is a problem with your side airbags.

When you turn the ignition switch to the ON (II) position, the indicator should come on briefly and go off (see page 57). If it doesn't come on, stays on, or comes on while driving without a passenger in the front seat, have the system checked.

Additional Information About Your Airbags

How the Passenger Airbag Off Indicator Works

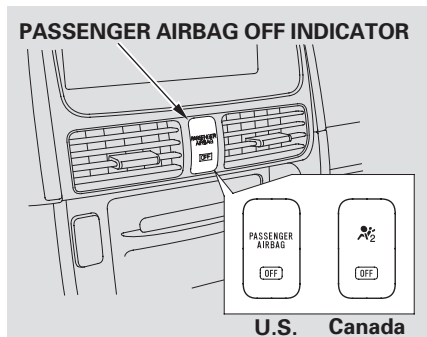

This indicator alerts you that the passenger's front airbag has been shut off because weight sensors detect an infant or small child may be in the front passenger's seat. It does **not** mean there is a problem with the airbag.

If no one is riding in the front seat, the airbag will be automatically shut off. However, the indicator will not come on.

If the indicator comes on with no passenger in the front, or with an adult in the seat, there may be a problem with the advanced airbag system. Have the vehicle checked by your dealer as soon as possible.

The passenger airbag off indicator may also come on and off repeatedly if total weight on the seat is near the airbag cutoff threshold.

If this happens, have the passenger ride properly restrained in a back seat. If the passenger must ride in front, move the seat as far to the rear as possible, have the passenger sit upright and wear the seat belt properly.

Airbag Service

Your airbag systems are virtually maintenance free, and there are no parts you can safely service. However, you must have your vehicle serviced if:

- ***An airbag ever inflates.*** Any airbag that has deployed must be replaced along with the control unit and other related parts. Any seat belt tensioner that activates must also be replaced.

Do not try to remove or replace any airbag by yourself. This must be done by your dealer or a knowledgeable body shop.

- ***The SRS indicator alerts you to a problem.*** Take your vehicle to an authorized dealer as soon as possible. If you ignore this indication, your airbags may not operate properly.

- ***If your vehicle has a moderate to severe impact.*** Even if your airbags do not inflate, your dealer should inspect the driver's seat position sensor, the front passenger's weight sensors, the front seat belt tensioners, and all seat belts worn during the crash to make sure they are operating properly.

Additional Safety Precautions

- ***Do not attempt to deactivate your airbags.*** Together, airbags and seat belts provide the best protection.
- ***Do not tamper with airbag components or wiring for any reason.*** Tampering could cause the airbags to deploy, possibly causing very serious injury.
- ***Do not remove or modify a front seat without consulting your dealer.*** This could make the driver's seat position sensor or the front passenger's weight sensors ineffective. If it is necessary to remove or modify a front seat to accommodate a person with disabilities, first contact Honda Automobile Customer Service at (800) 999-1009.

- ***Do not expose the front seat-backs to liquid.*** If water or another liquid soaks into a seat-back, it can prevent the side airbag cutoff system from working properly.
- ***Do not cover or replace front seat-back covers without consulting your dealer.*** Improperly replacing or covering front seat-back covers can prevent your side airbags from inflating during a side impact.



Children depend on adults to protect them. However, despite their best intentions, many adults do not know how to *properly* protect child passengers.

If you have children, or ever need to drive with a child in your vehicle, be sure to read this section. It begins with important general guidelines, then presents special information for infants, small children, and larger children.

All Children Must Be Restrained

Each year, many children are injured or killed in vehicle crashes because they are either unrestrained or not properly restrained. In fact, vehicle accidents are the number one cause of the death of children aged 12 and under.

To reduce the number of child deaths and injuries, every state and Canadian province requires that infants and children be properly restrained when they ride in a vehicle.

Infants and small children must be restrained in an approved child seat that is properly secured to the vehicle (see pages 37 – 46).

⚠ WARNING

Children who are unrestrained or improperly restrained can be seriously injured or killed in a crash.

Any child too small for a seat belt should be properly restrained in a child seat. A larger child should be properly restrained with a seat belt and use a booster seat if necessary.

Larger children must be restrained with a lap/shoulder belt and ride on a booster seat until the seat belt fits them properly (see pages 46 – 49).

All Children Should Sit in a Back Seat

According to accident statistics, children of all ages and sizes are safer when they are restrained in a back seat. The National Highway Traffic Safety Administration and Transport Canada recommend that all children aged 12 and under be properly restrained in a back seat. Some states have laws restricting where children may ride.

Children who ride in back are less likely to be injured by striking interior vehicle parts during a collision or hard braking. Also, children cannot be injured by an inflating front airbag when they ride in the back.

The Passenger's Front Airbag Can Pose Serious Risks

Front airbags have been designed to help protect adults in a moderate to severe frontal collision. To do this, the passenger's front airbag is quite large, and it can inflate with enough force to cause very serious injuries.

Even though your vehicle has an advanced front airbag system that automatically turns the passenger's front airbag off (see page 30), please follow these guidelines:

Infants

Never put a rear-facing child seat in the front seat of a vehicle equipped with a passenger's front airbag. If the airbag inflates, it can hit the back of the child seat with enough force to kill or very seriously injure an infant.

Small Children

Placing a forward-facing child seat in the front seat of a vehicle equipped with a passenger's front airbag can be hazardous. If the vehicle seat is too far forward, or the child's head is thrown forward during a collision, an inflating front airbag can strike the child with enough force to kill or very seriously injure a small child.

Larger Children

Children who have outgrown child seats are also at risk of being injured or killed by an inflating passenger's front airbag. Whenever possible, larger children should sit in the back seat, on a booster seat if needed, and be properly restrained with a seat belt (see page 46 for important information about protecting larger children).

CONTINUED

Protecting Children – General Guidelines

To remind you of the passenger's front airbag hazards, and that children must be properly restrained in a back seat, your vehicle has warning labels on the dashboard (U.S. models) and on the front visors. Please read and follow the instructions on these labels.

U.S. Models

SUN VISOR



DASHBOARD

This Vehicle is Equipped with
Advanced Air Bags

Even with Advanced Air Bags

Children can be killed or seriously injured by the air bag.
The back seat is the safest place for children.
Never put a rear-facing child seat in the front.
Always use seat belts and child restraints.
See owner's manual for more information about air bags.

To be removed by owner only.

Canadian Models

SUN VISOR

CAUTION

TO AVOID SERIOUS INJURY:

- FOR MAXIMUM SAFETY PROTECTION IN ALL TYPES OF CRASHES, YOU MUST ALWAYS WEAR YOUR SAFETY BELT.
- DO NOT INSTALL REARWARD-FACING CHILD SEATS IN ANY FRONT PASSENGER SEAT POSITION.
- DO NOT SIT OR LEAN UNNECESSARILY CLOSE TO THE AIR BAG.
- DO NOT PLACE ANY OBJECTS OVER THE AIR BAG OR BETWEEN THE AIR BAG AND YOURSELF.
- SEE THE OWNER'S MANUAL FOR FURTHER INFORMATION AND EXPLANATIONS.

PRÉCAUTION:

POUR ÉVITER DES BLESSURES GRAVES:

- POUR PROFITER D'UNE PROTECTION MAXIMALE LORS D'UNE COLLISION BOUCLEZ TOUJOURS VOTRE CEINTURE DE SECURITE.
- N'INSTALLEZ JAMAIS UN SIEGE POUR ENFANTS FAISANT FACE A L'ARRIERE SUR LE SIEGE DU PASSAGER AVANT.
- NE VOUS APPUYEZ PAS ET NE VOUS ASSEYEZ PAS PRES DU COUSSIN GONFLABLE.
- NE DEPOSEZ AUCUN OBJET SUR LE COUSSIN GONFLABLE OU ENTRE LE COUSSIN GONFLABLE ET VOUS.
- LISEZ LE GUIDE UTILISATEUR POUR DE PLUS AMPLES RENSEIGNEMENTS.

If You Must Drive with Several Children

Your vehicle has a back seat where children can be properly restrained. If you ever have to carry a group of children, and a child must ride in front:

- Place the largest child in the front seat, provided the child is large enough to wear the lap/shoulder belt properly (see page 46).
- Move the vehicle seat as far to the rear as possible (see page 78).
- Have the child sit upright and well back in the seat (see page 15).
- Make sure the seat belt is properly positioned and secured (see page 14).

If a Child Requires Close Attention

Many parents say they prefer to put an infant or small child in the front passenger seat so they can watch the child, or because the child requires attention.

Placing a child in the front seat exposes the child to hazards in a frontal collision, and paying close attention to a child distracts the driver from the important tasks of driving, placing both of you at risk.

If a child requires close physical attention or frequent visual contact, we strongly recommend that another adult ride with the child in a back seat. The back seat is far safer for a child than the front.

Additional Safety Precautions

- **Never hold an infant or child on your lap.** If you are not wearing a seat belt in a crash, you could be thrown forward and crush the child against the dashboard or a seat-back. If you are wearing a seat belt, the child can be torn from your arms and be seriously hurt or killed.
- **Never put a seat belt over yourself or a child.** During a crash, the belt could press deep into the child and cause serious or fatal injuries.
- **Never let two children use the same seat belt.** If they do, they could be very seriously injured in a crash.

CONTINUED

Protecting Children – General Guidelines

- **Use the childproof door locks to prevent children from opening the rear doors.** This can prevent children from accidentally falling out (see page 73).
- **Do not leave children alone in a vehicle.** Leaving children without adult supervision is illegal in most states and Canadian provinces, and can be very hazardous.

For example, infants and small children left in a vehicle on a hot day can die from heatstroke. A child left alone with the key in the ignition switch can accidentally set the vehicle in motion, possibly injuring themselves or others.

- **Lock all doors, the tailgate and the hatch when your vehicle is not in use.** Children who play in vehicles can accidentally get trapped inside. Teach your children not to play in or around vehicles.
- **Keep vehicle keys/remote transmitters out of the reach of children.** Even very young children learn how to unlock vehicle doors, turn on the ignition switch, and open the tailgate or hatch glass, which can lead to accidental injury or death.

Protecting Infants

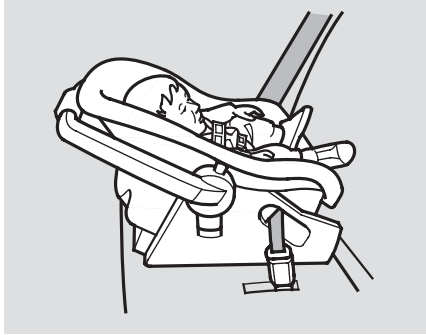

Child Seat Type

An infant must be properly restrained in a rear-facing, reclining child seat until the child reaches the seat maker's weight or height limit for the seat and the child is at least one year old.

Only a rear-facing child seat provides proper support for a baby's head, neck, and back.

Two types of seats may be used: a seat designed exclusively for infants, or a convertible seat used in the rear-facing, reclining mode.

Do not put a rear-facing child seat in a forward-facing position. If placed facing forward, an infant could be very seriously injured during a frontal collision.

Rear-facing Child Seat Placement
A rear-facing child seat can be placed in any seating position in the back seat, but not in the front. ***Never put a rear-facing child seat in the front seat.***

If the passenger's front airbag inflates, it can hit the back of the child seat with enough force to kill or seriously injure an infant.

When properly installed in the back seat, a rear-facing child seat may prevent the driver or a front passenger from moving their seat as far back as recommended, or from locking their seat-back in the desired position. It could also interfere with proper operation of the passenger's advanced front airbag system.

CONTINUED

Protecting Infants and Small Children

In any of these situations, we strongly recommend that you install the child seat directly behind the front passenger's seat, move the seat as far forward as needed, and leave it unoccupied. Or, you may wish to get a smaller rear-facing child seat.

⚠ WARNING

Placing a rear-facing child seat in the front seat can result in serious injury or death during a collision.

Always place a rear-facing child seat in the back seat, not the front.

Protecting Small Children



Child Seat Type

A child who is at least one year old, and who fits within the child seat maker's weight and height limits, should be restrained in a forward-facing, upright child seat.

Of the different seats available, we recommend those that have a five-point harness system as shown.

We also recommend that a small child use the child seat until the child reaches the weight or height limit for the seat.

Child Seat Placement

We strongly recommend placing a forward-facing child seat in a back seat, not the front.

Placing a forward-facing child seat in the front seat of a vehicle equipped with a passenger's airbag can be hazardous. If the vehicle seat is too far forward, or the child's head is thrown forward during a collision, an inflating airbag can strike the child with enough force to cause very serious or fatal injuries.

Even with advanced front airbags that automatically turn the passenger's front airbag off (see page 30), a back seat is the safest place for a small child.

If it is necessary to put a forward-facing child seat in the front, move the vehicle seat as far to the rear as possible, and be sure the child seat is firmly secured to the vehicle and the child is properly strapped in the seat.

⚠ WARNING

Placing a forward-facing child seat in the front seat can result in serious injury or death if the front airbag inflates.

If you must place a forward-facing child seat in front, move the vehicle seat as far back as possible, and properly restrain the child.

Selecting a Child Seat

When buying a child seat, you need to choose either a conventional child seat, or one designed for use with the lower anchors and tethers for children (LATCH) system.

Conventional child seats must be secured to a vehicle with a seat belt, whereas LATCH-compatible seats are secured by attaching the seat to hardware built into the two outer seating positions in the back seat.

Since LATCH-compatible child seats are easier to install and reduce the possibility of improper installation, we recommend selecting this style.

We also recommend selecting a LATCH-compatible seat with a rigid, rather than a flexible, anchor (see page 41).

In seating positions and vehicles not equipped with LATCH, a LATCH-compatible child seat can be installed using a seat belt.

Whatever type of seat you choose, to provide proper protection, a child seat should meet three requirements:

- 1. The child seat should meet U.S. or Canadian Motor Vehicle Safety Standard 213.*** Look for FMVSS 213 or CMVSS 213 on the box.
- 2. The child seat should be of the proper type and size to fit the child.*** Rear-facing for infants, forward-facing for small children.

CONTINUED

Selecting a Child Seat, Installing a Child Seat

3. The child seat should fit the vehicle seating position (or positions) where it will be used.

Before purchasing a conventional child seat, or using a previously purchased one, we recommend that you test the seat in the specific vehicle seating position (or positions) where the seat will be used.

Installing a Child Seat

After selecting a proper child seat and a good place to install the seat, there are three main steps in installing the seat:

1. Properly secure the child seat to the vehicle. All child seats must be secured to the vehicle with the lap part of a lap/shoulder belt or with the LATCH (lower anchors and tethers for children) system. A child whose seat is not properly secured to the vehicle can be endangered in a crash.

2. Make sure the child seat is firmly secured. After installing a child seat, push and pull the seat forward and from side-to-side to verify that it is secure.

A child seat secured with a seat belt should be installed as firmly as possible. However, it does not need to be “rock solid.” Some side-to-side

movement can be expected and should not reduce the child seat’s effectiveness.

If the child seat is not secure, try installing it in a different seating position, or use a different style of child seat that can be firmly secured.

3. Secure the child in the child seat.

Make sure the child is properly strapped in the child seat according to the child seat maker’s instructions. A child who is not properly secured in a child seat can be seriously injured in a crash.

The following pages provide guidelines on how to properly install a child seat. A forward-facing child seat is used in all examples, but the instructions are the same for rear-facing child seats.

Installing a Child Seat with LATCH

Your vehicle is equipped with LATCH (lower anchors and tethers for children) at the outer rear seats.

The lower anchors are located between the seat-back and seat bottom, and are to be used only with a child seat designed for use with LATCH.

The location of each lower anchor is indicated by a small button above the anchor point.

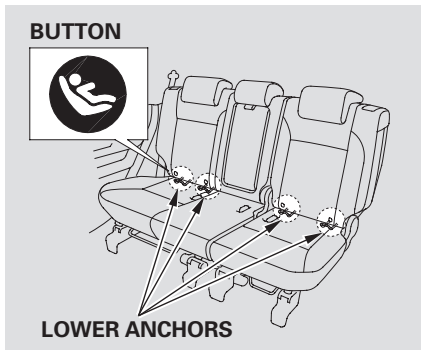

To install a LATCH-compatible child seat:

1. Move the seat belt buckle or tongue away from the lower anchors.
2. Make sure there are no objects near the anchors that could prevent a secure connection between the child seat and the anchors.

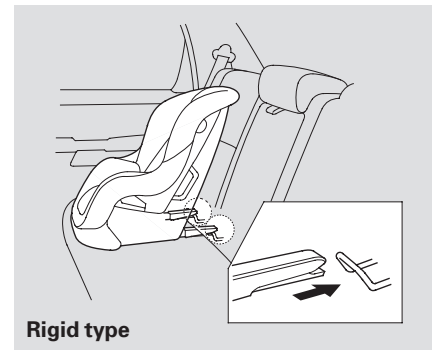

3. Place the child seat on the vehicle seat, then attach the seat to the lower anchors according to the child seat maker's instructions.

Some LATCH-compatible seats have a rigid-type connector as shown above.

CONTINUED

Installing a Child Seat

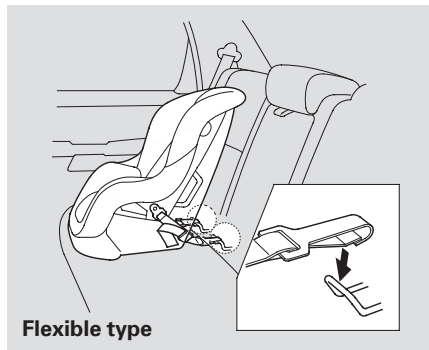

Other LATCH-compatible seats have a flexible-type connector as shown above.

4. Whatever type you have, follow the child seat maker's instructions for adjusting or tightening the fit.

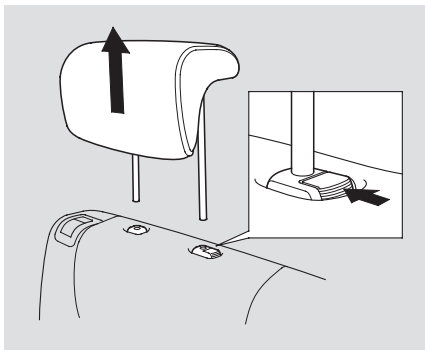

5. Remove the head restraint (see page 80). Make sure the removed head restraint is secured in the cargo area. Reinstall the head restraint when the child seat is removed.
6. Route the tether strap over the seat-back, making sure the strap is not twisted.
7. Locate the appropriate anchor cover, and pull it down and out to expose the tether anchor.

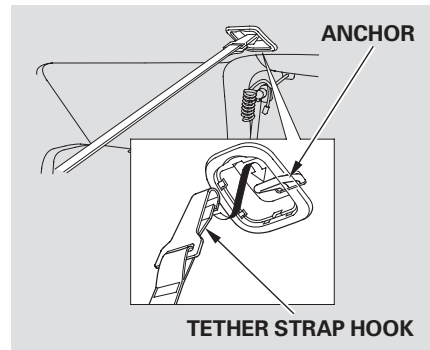

8. Attach the tether strap hook to the tether anchor in the ceiling, then tighten the strap as instructed by the child seat maker.
9. Push and pull the child seat forward and from side-to-side to verify that it is secure.

Installing a Child Seat with a Lap/Shoulder Belt

When not using the LATCH system, all child seats must be secured to the vehicle with the lap part of a lap/shoulder belt.

In addition, the lap/shoulder belts in all seating positions except the driver's have a locking mechanism that must be activated to secure a child seat.

If you intend to install a child seat in the center seating position of the rear seat, make sure the detachable seat belt anchor is securely latched.

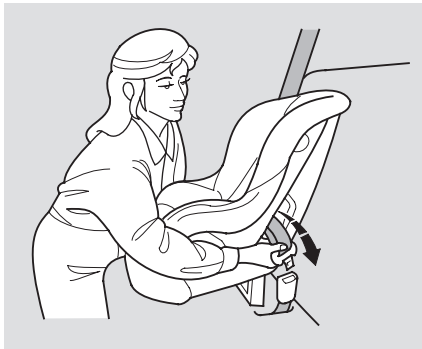

1. With the child seat in the desired seating position, route the belt through the child seat according to the seat maker's instructions, then insert the latch plate into the buckle.

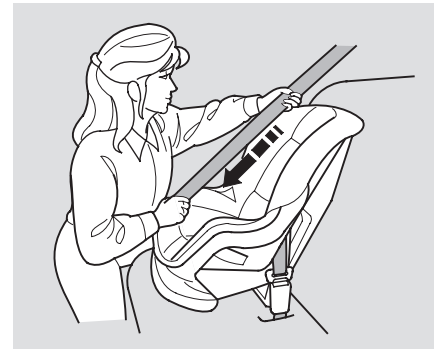

2. To activate the lockable retractor, slowly pull the shoulder part of the belt all the way out until it stops, then let the belt feed back into the retractor.
3. After the belt has retracted, tug on it. If the belt is locked, you will not be able to pull it out. If you can pull the belt out, it is not locked, and you will need to repeat these steps.

CONTINUED

Installing a Child Seat



4. After confirming that the belt is locked, grab the shoulder part of the belt near the buckle, and pull up to remove any slack from the lap part of the belt. Remember, if the lap part of the belt is not tight, the child seat will not be secure.

To remove slack, it may help to put weight on the child seat, or push on the back of the seat while pulling up on the belt.



5. Push and pull the child seat forward and from side-to-side to verify that it is secure enough to stay upright during normal driving maneuvers. If the child seat is not secure, unlatch the belt, allow it to retract fully, then repeat these steps.

To deactivate the locking mechanism and remove a child seat, unlatch the buckle, unrout the seat belt, and let the belt fully retract.

Installing a Child Seat with a Tether

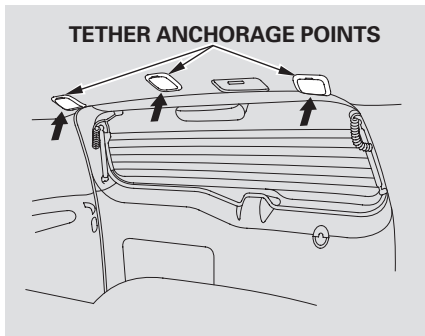

A child seat with a tether can be installed in any seating position in the back seat, using one of the anchorage points shown above.

Since a tether can provide additional security to the lap/shoulder belt installation, we recommend using a tether whenever one is required or available.

Using an Outer Anchor

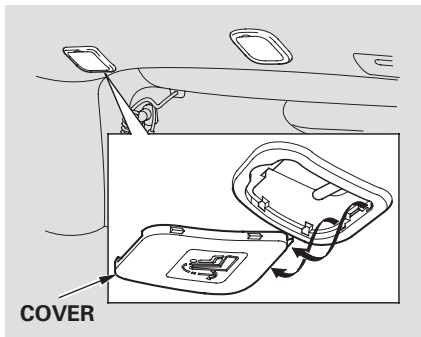

1. After properly securing the child seat (see page 43), remove the head restraint, then route the tether strap over the seat-back. Make sure to store the removed head restraint in the cargo area and to reinstall it when the child seat is removed.

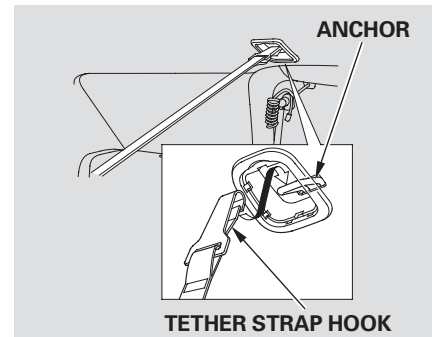

2. Remove the cover with a small flat-tipped screwdriver or fingernail file.
3. Attach the tether strap hook to the anchor, making sure the strap is not twisted.
4. Tighten the strap according to the seat maker's instructions.

CONTINUED

Installing a Child Seat, Protecting Larger Children

Using the Center Anchor

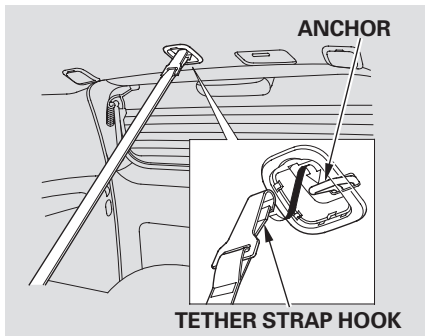

1. After properly securing the child seat (see page 43), remove the head restraint, then route the tether strap over the seat-back. Make sure to store the removed head restraint in the cargo area and to reinstall it when the child seat is removed.
2. Follow steps 2 through 4 in the previous page.

Protecting Larger Children

When a child reaches the recommended weight or height limit for a forward-facing child seat, the child should sit in a back seat on a booster seat and wear a lap/shoulder belt.

The following pages give instructions on how to check proper seat belt fit, what kind of booster seat to use if one is needed, and important precautions for a child who must sit in front.

⚠️ WARNING

Allowing a child age 12 or under to sit in front can result in injury or death if the passenger's front airbag inflates.

If a child must ride in front, move the vehicle seat as far back as possible, use a booster seat if needed, have the child sit up properly and wear the seat belt properly.

Checking Seat Belt Fit

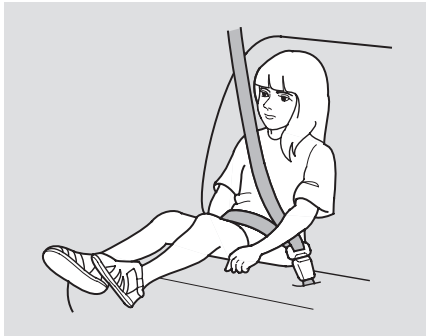

To determine if a lap/shoulder belt properly fits a child, have the child put on the seat belt, then ask yourself:

1. Does the child sit all the way back against the seat?
2. Do the child's knees bend comfortably over the edge of the seat?

3. Does the shoulder belt cross between the child's neck and arm?
4. Is the lap part of the belt as low as possible, touching the child's thighs?
5. Will the child be able to stay seated like this for the whole trip?

If you answer yes to all these questions, the child is ready to wear the lap/shoulder belt correctly. If you answer no to any question, the child needs to ride on a booster seat.

Using a Booster Seat



A child who has outgrown a forward-facing child seat should ride in a back seat and use a booster seat until the lap/shoulder belt fits them properly without the booster.

CONTINUED

Protecting Larger Children

Some states and Canadian provinces also require children to use a booster seat until they reach a given age or weight (e.g., 6 years or 60 lbs). Be sure to check current laws in the states or provinces where you intend to drive.

Booster seats can be high-back or low-back. Whichever style you select, make sure the booster seat meets federal safety standards (see page 33) and that you follow the booster seat maker's instructions.

If a child who uses a booster seat must ride in front, move the vehicle seat as far back as possible and be sure the child is wearing the seat belt properly.

A child may continue using a booster seat until the tops of their ears are even with the top of the vehicle's or booster's seat-back. A child of this height should be tall enough to use the lap/shoulder belt without a booster seat.

When Can a Larger Child Sit in Front

The National Highway Traffic Safety Administration and Transport Canada recommend that all children age 12 and under be properly restrained in a back seat.

If the passenger's front airbag inflates in a moderate to severe frontal collision, the airbag can cause serious injuries to a child who is unrestrained, improperly restrained, sitting too close to the airbag, or out of position.

A side airbag also poses risks. If any part of a larger child's body is in the path of a deploying side airbag, the child could receive possibly serious injuries.

Of course, children vary widely. And while age may be one indicator of when a child can safely ride in front, there are other important factors you should consider.

Physical Size

Physically, a child must be large enough for the lap/shoulder belt to properly fit (see pages 14 and 47). If the seat belt does not fit properly, with or without the child sitting on a booster seat, the child should not sit in front.

Maturity

To safely ride in front, a child must be able to follow the rules, including sitting properly, and wearing the seat belt properly throughout a ride.

If you decide that a child can safely ride up front, be sure to:

- Carefully read the owner's manual, and make sure you understand all seat belt instructions and all safety information.
- Move the vehicle seat to the rear-most position.
- Have the child sit up straight, back against the seat, and feet on or near the floor.
- Check that the child's seat belt is properly and securely positioned.
- Supervise the child. Even a mature children sometimes needs to be reminded to fasten the seat belts or sit properly.

Additional Safety Precautions

- ***Do not let a child wear a seat belt across the neck.*** This could result in serious neck injuries during a crash.
- ***Do not let a child put the shoulder part of a seat belt behind the back or under the arm.*** This could cause very serious injuries during a crash. It also increases the chance that the child will slide under the belt in a crash and be injured.
- ***Two children should never use the same seat belt.*** If they do, they could be very seriously injured in a crash.

- ***Do not put any accessories on a seat belt.*** Devices intended to improve a child's comfort or reposition the shoulder part of a seat belt can make the belt less effective and increase the chance of serious injury in a crash.

Carbon Monoxide Hazard

Your vehicle's exhaust contains carbon monoxide gas. You should have no problem with carbon monoxide entering the vehicle in normal driving if you maintain your vehicle properly.

Have the exhaust system inspected for leaks whenever:

- The vehicle is raised for an oil change.
- You notice a change in the sound of the exhaust.
- The vehicle was in an accident that may have damaged the underside.

WARNING

Carbon monoxide gas is toxic. Breathing it can cause unconsciousness and even kill you.

Avoid any enclosed areas or activities that expose you to carbon monoxide.

High levels of carbon monoxide can collect rapidly in enclosed areas, such as a garage. Do not run the engine with the garage door closed. Even with the door open, run the engine only long enough to move the vehicle out of the garage.

With the tailgate/hatch glass open, airflow can pull exhaust gas into your vehicle's interior and create a hazardous condition. If you must drive with the tailgate/hatch glass open, open all the windows and set the heating and cooling system as shown below.

If you must sit in your parked vehicle with the engine running, even in an unconfined area, adjust the heating and cooling system as follows:

1. Select the fresh air mode.
2. Select the  mode.
3. Turn the fan on high speed.
4. Set the temperature control to a comfortable setting.

These labels are in the locations shown. They warn you of potential hazards that could cause serious injury or death. Read these labels carefully.

If a label comes off or becomes hard to read (except for the U.S. dashboard label which may be removed by the owner), contact your dealer for a replacement.

SUN VISOR

U.S. models

▲ WARNING

EVEN WITH ADVANCED AIR BAGS



- Children can be killed or seriously injured by the air bag
- The back seat is the safest place for children
- Never put a rear-facing child seat in the front
- Always use seat belts and child restraints
- See owner's manual for more information about air bags

Canadian models

<p>CAUTION</p> <p>TO AVOID SERIOUS INJURY:</p> <ul style="list-style-type: none"> • FOR MAXIMUM SAFETY PROTECTION IN ALL TYPES OF CRASHES YOU MUST ALWAYS WEAR YOUR SAFETY BELT. • DO NOT INSTALL REARWARD-FACING CHILD SEATS IN ANY FRONT PASSENGER SEAT POSITION. • DO NOT SIT OR LEAN UNNECESSARILY CLOSE TO THE AIR BAG. • DO NOT PLACE ANY OBJECTS OVER THE AIR BAG OR BETWEEN THE AIR BAG AND YOURSELF. • SEE THE OWNER'S MANUAL FOR FURTHER INFORMATION AND EXPLANATIONS. 	<p>PRECAUTIONS:</p> <p>POUR ÉVITER DES BLESSURES GRAVES:</p> <ul style="list-style-type: none"> • POUR PROFITER D'UNE PROTECTION MAXIMALE LORS D'UNE COLLISION BOUCLEZ TOUJOURS VOTRE CEINTURE DE SÉCURITÉ. • N'INSTALLEZ JAMAIS UN SIÈGE POUR ENFANTS FAISANT FACE À L'ARRIÈRE SUR LE SIÈGE DU PASSAGER AVANT. • NE VOUS APPUYEZ PAS ET NE VOUS ASSOYEZ PAS PRES DU COUSSIN GONFLABLE. • NE DEPOSEZ AUCUN OBJET SUR LE COUSSIN GONFLABLE OU ENTRE LE COUSSIN GONFLABLE ET VOUS. • LISEZ LE GUIDE UTILISATEUR POUR DE PLUS AMPLES RENSEIGNEMENTS.
---	--

DASHBOARD

U.S. models only

This Vehicle is Equipped with Advanced Air Bags

Even with Advanced Air Bags

Children can be killed or seriously injured by the air bag.
The back seat is the safest place for children.
Never put a rear-facing child seat in the front.
Always use seat belts and child restraints.
See owner's manual for more information about air bags.

To be removed by owner only.

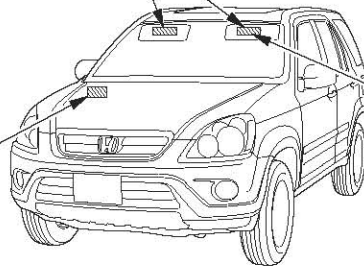

SUN VISOR

U.S. models only

▲ WARNING: HIGHER ROLLOVER RISK



Avoid Abrupt Maneuvers and Excessive Speed.

Always Buckle Up.

See Owner's Manual For Further Information.



CONTINUED

Safety Labels

HOOD

U.S. models

▲ ATTENTION

Accidental deployment can seriously hurt or kill you.
Follow Service Manual instructions carefully.

Canadian models

▲ ATTENTION

Accidental deployment can seriously hurt or kill you.
Follow Service Manual instructions carefully.

▲ ATTENTION

Un déploiement accidentel peut entraîner des blessures graves ou la mort.
Suivre les instructions du manuel de réparation attentivement.

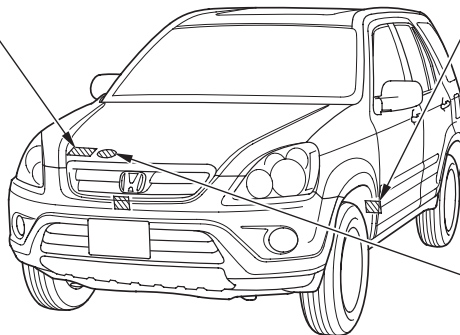

DOORJAMBS

U.S. models

SIDE AIRBAG

- This car is equipped with side airbags in the front seats and side curtain airbags.
- Do not lean against the door.
- See owner's manual for more information.

Canadian models

SIDE AIRBAG

- This car is equipped with side airbags in the front seats and side curtain airbags.
- Do not lean against the door.
- See owner's manual for more information.

COUSSIN GONFLABLE LATÉRAL

- Cette automobile est équipée de coussins gonflables latéraux dans les sièges avant ainsi que de coussins gonflables latéraux de type rideau.
- Ne vous appuyez pas sur la porte.
- Consultez le Manuel du propriétaire pour en savoir plus.

RADIATOR CAP



This section gives information about the controls and displays that contribute to the daily operation of your vehicle. All the essential controls are within easy reach.

Control Locations	54	Tailgate and Hatch Glass.....	74
Instrument Panel	55	Remote Transmitter.....	75
Instrument Panel Indicators.....	56	Seats	78
Gauges	61	Seat Heaters	86
Trip Meter	61	Power Windows	86
Odometer.....	62	Moonroof	88
Fuel Gauge	62	Mirrors.....	88
Temperature Gauge.....	62	Interior Convenience Items.....	90
Outside Temperature		Beverage Holders.....	91
Indicator	62	Built-in Table.....	91
Check Fuel Cap Indicator.....	63	Glove Box	93
Controls Near the Steering		Coin Tray	93
Wheel.....	64	Sunglasses Holder	94
Windshield Wipers and Washers ..	65	Center Table.....	94
Turn Signals and Headlights.....	66	Accessory Power Sockets.....	95
Instrument Panel Brightness	67	Center Pocket	95
Hazard Warning Button.....	67	Sun Visor.....	95
Rear Window Defogger	68	Interior Lights	95
Parking Brake	68		
Steering Wheel Adjustment	69		
Keys and Locks.....	70		
Immobilizer System.....	71		
Ignition Switch	72		
Door Locks	73		
Power Door Locks.....	73		
Childproof Door Locks	73		

Control Locations

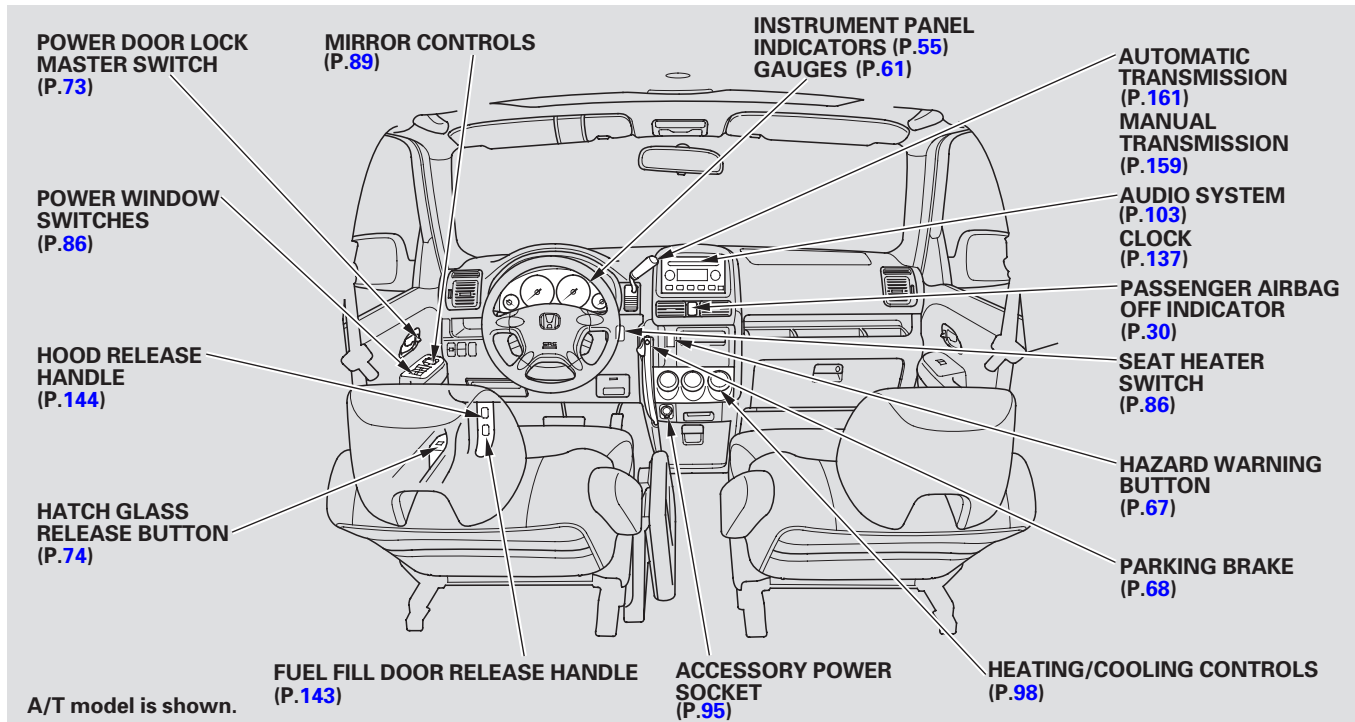

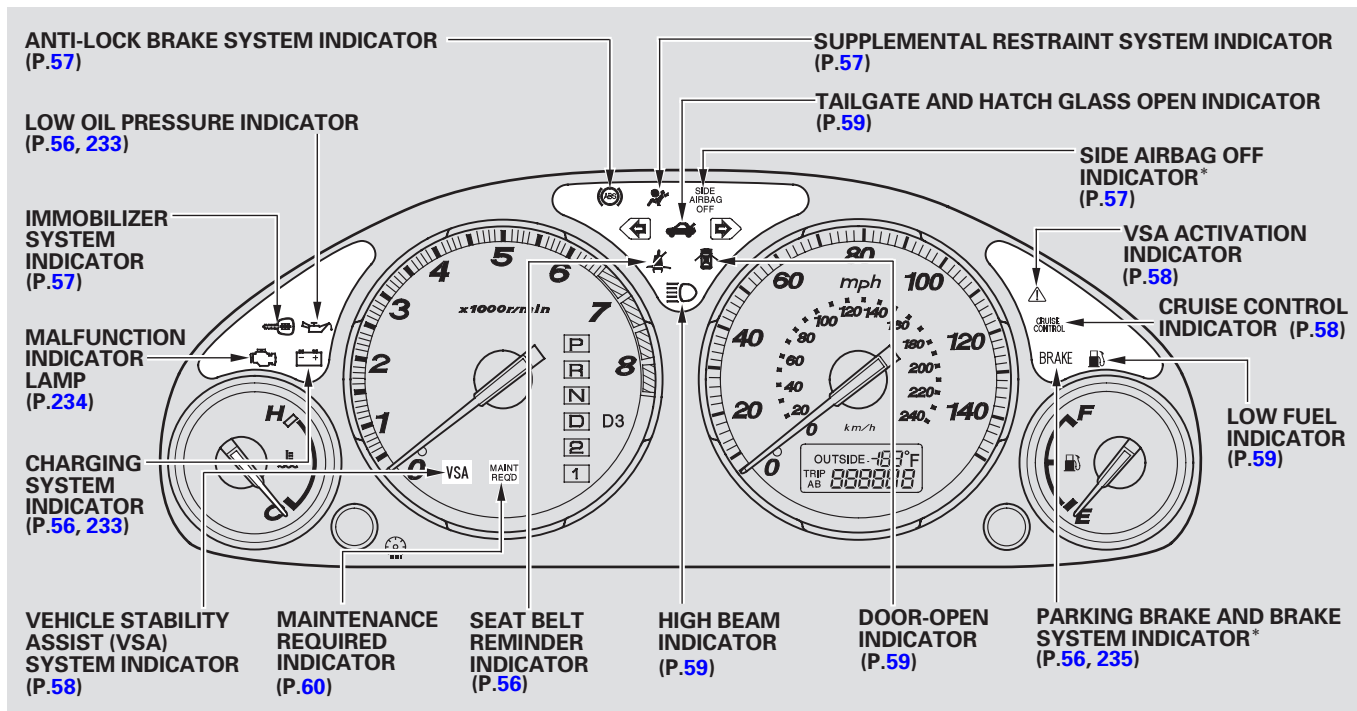

* The U.S. instrument panel is shown. Differences for the Canadian models are noted in the text.

Instrument Panel Indicators

The instrument panel has many indicators that give you important information about your vehicle.



Malfunction Indicator Lamp

See page [234](#).



Low Oil Pressure Indicator

The engine can be severely damaged if this indicator flashes or stays on when the engine is running. For more information, see page [233](#).



Charging System Indicator

If this indicator comes on when the engine is running, the battery is not being charged. For more information, see page [233](#).

U.S. Canada

BRAKE



Parking Brake and Brake System Indicator

This indicator has two functions:

1. It comes on when you turn the ignition switch to the ON (II) position. It is a reminder to check the parking brake. Driving with the parking brake not fully released can damage the brakes and tires.
2. If it remains on after you have fully released the parking brake while the engine is running, or if it comes on while driving, there could be a problem with the brake system. For more information, see page [235](#).



Seat Belt Reminder Indicator

This indicator comes on when you turn the ignition switch to the ON (II) position. It reminds you and your passengers to fasten your seat belts. A beeper also sounds if you have not fastened your seat belt.

If you do not fasten your seat belt, the beeper will stop after a few seconds but the indicator stays on until you do. Both the indicator and the beeper stay off if you fasten your seat belt before turning on the ignition switch.

If you continue driving without fastening your seat belt, the beeper sounds and the indicator flashes again at regular intervals.



Supplemental Restraint System Indicator

This indicator comes on briefly when you turn the ignition switch to the ON (II) position. If it comes on at any other time, it indicates a potential problem with your front airbags. This indicator will also alert you to a potential problem with your side airbags, passenger's side airbag automatic cutoff system, side curtain airbags, automatic seat belt tensioners, driver's seat position sensor, or the front passenger's weight sensors. For more information, see page 29 .

U.S.



Canada



Side Airbag Off Indicator

This indicator comes on when you turn the ignition switch to the ON (II) position. If it comes on at any other time, it indicates that the passenger's side airbag has

automatically shut off. For more information, see page 29 .



Anti-lock Brake System (ABS) Indicator

This indicator normally comes on for a few seconds when you turn the ignition switch to the ON (II) position, and when the ignition switch is turned to the START (III) position. If it comes on at any other time, there is a problem with the ABS. If this happens, have your vehicle checked at a dealer. With this indicator on, your vehicle still has normal braking ability but no anti-lock function. For more information, see page 168 .



Immobilizer System Indicator

This indicator comes on for a few seconds when you turn the ignition switch to the ON (II) position. It will then go off if you have inserted a properly-coded ignition key. If it is not a properly-coded key, the indicator will blink, and the engine will not start (see page 71).

This indicator also blinks several times when you turn the ignition switch from the ON (II) position to the ACCESSORY (I) or the LOCK (0) position.

Instrument Panel Indicators

Vehicle Stability Assist (VSA) System Indicator

This indicator normally comes on for a few seconds when you turn the ignition switch to the ON (II) position.

If it comes on and stays on at any other time, or if it does not come on when you turn the ignition switch to the ON (II) position, there is a problem with the VSA system. Take your vehicle to a dealer to have it checked. Without VSA, your vehicle still has normal driving ability, but will not have VSA traction and stability enhancement. See page [170](#) for more information on the VSA system.



VSA Activation Indicator

This indicator has three functions.

1. It comes on as a reminder that you have turned off the vehicle stability assist (VSA) system.
2. It flashes when VSA is active (see page [170](#)).
3. It comes on along with the VSA system indicator if there is a problem with the VSA system.

This indicator normally comes on for a few seconds when you turn the ignition switch to the ON (II) position. See page [170](#) for more information on the VSA system.



Cruise Control Indicator

This indicator comes on when you set the cruise control. See page [138](#) for information on operating the cruise control.



Turn Signal and Hazard Warning Indicators

The left or right turn signal indicator blinks when you signal a lane change or turn. If an indicator does not blink or blinks rapidly, it usually means one of the turn signal bulbs is burned out (see page 205). Replace the bulb as soon as possible, since other drivers cannot see that you are signaling.

When you press the hazard warning button, both turn signal indicators and all turn signals on the outside of the vehicle flash.



High Beam Indicator

This indicator comes on with the high beam headlights. For more information, see page 67.

On Canadian models, this indicator comes on with reduced brightness when the daytime running lights (DRL) are on (see page 67).



Daytime Running Lights Indicator

Canadian models only

This indicator comes on when you turn the ignition switch to the ON (II) position with the headlight switch off and the parking brake set. It should go off if you turn on the headlights or release the parking brake. If it comes on at any other time, it means there is a problem with the DRL. There may also be a problem with the high beam headlights.



Low Fuel Indicator

This indicator comes on as a reminder that you must refuel soon.

When the indicator comes on, there is about 2.74 US gal (10.4 l) of fuel remaining in the tank before the needle reaches E. There is a small reserve of fuel remaining in the tank when the needle does reach E.



Tailgate and Hatch Glass Open Indicator

This indicator comes on if the tailgate or the hatch glass is not closed tightly.



Door-open Indicator

This indicator comes on if any door is not closed tightly.

Instrument Panel Indicators



Washer Level Indicator

Canadian models only

This indicator comes on when the washer fluid level is low. Add washer fluid when you see this indicator (see page [198](#)).



Maintenance Required Indicator

This indicator reminds you that it is time to take your vehicle in for scheduled maintenance.

Refer to the maintenance schedule for normal and severe driving conditions on pages [187](#) and [188](#).

For the first 8,000 miles (12,800 km) after the maintenance required indicator is reset, it will come on for 2 seconds when you turn the ignition switch to the ON (II) position.

Between 8,000 miles (12,800 km) and 10,000 miles (16,000 km), this indicator will come on for 2 seconds when you first turn the ignition switch to the ON (II) position, and then flash for 10 seconds.

If you exceed 10,000 miles (16,000 km) without having the scheduled maintenance performed, this indicator will remain on as a constant reminder.

Your dealer will reset this indicator after completing the scheduled maintenance. If this maintenance is done by someone other than your dealer, reset the indicator as follows.

1. Turn off the engine.

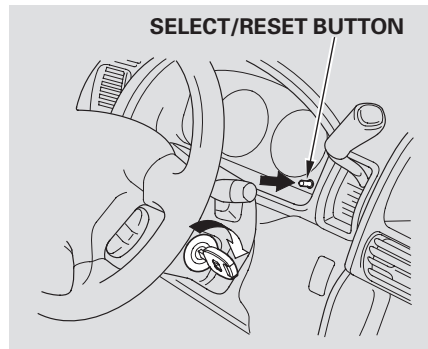

2. Press and hold the Select/Reset button on the instrument panel, then turn the ignition switch to the ON (II) position.
3. Hold the button for about 10 seconds until the indicator goes off.

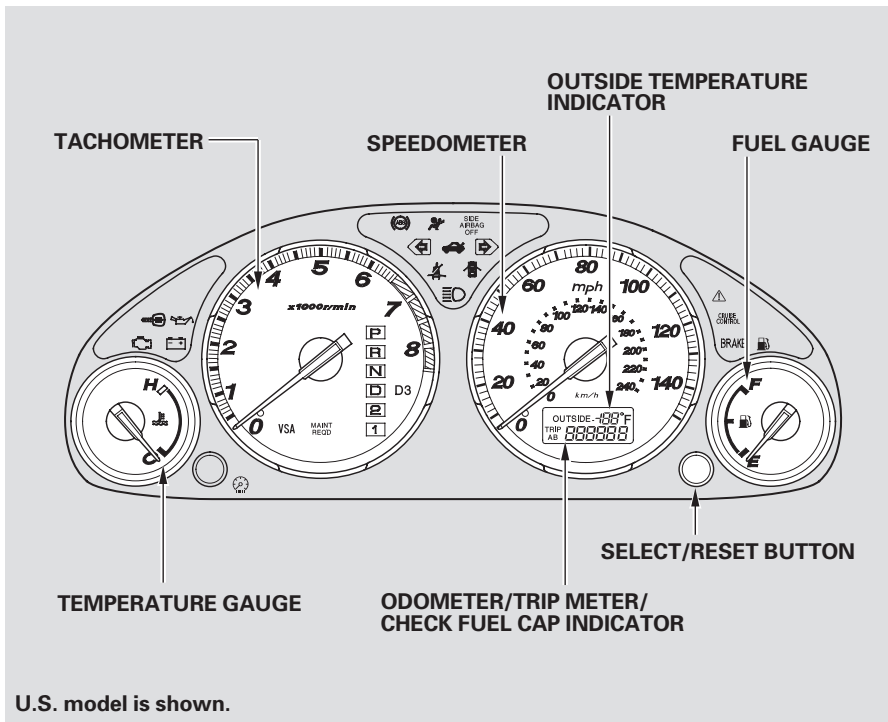

Trip Meter

This meter shows the number of miles (U.S.) or kilometers (Canada) driven since you last reset it.

There are two trip meters: Trip A and Trip B. Switch between these displays and the odometer display by pressing the Select/Reset button repeatedly.

Each trip meter works independently, so you can keep track of two different distances.

When you turn the ignition switch to the ON (II) position, the meter you last selected is displayed.

To reset a trip meter, display it, and then press and hold the Select/Reset button until the number resets to "0.0."

Gauges

Odometer

The odometer shows the total distance your vehicle has been driven. It measures miles in U.S. models and kilometers in Canadian models. It is illegal under U.S. federal law and Canadian provincial regulations to disconnect, reset, or alter the odometer with the intent to change the number of miles or kilometers indicated.

Fuel Gauge

This shows how much fuel you have. It may show slightly more or less than the actual amount. The needle returns to the bottom after you turn off the ignition.

NOTICE

Avoid driving with an extremely low fuel level. Running out of fuel could cause the engine to misfire, damaging the catalytic converter.

Temperature Gauge

This shows the temperature of the engine's coolant. During normal operation, the pointer should rise from the bottom white mark to about the middle of the gauge. In severe driving conditions, such as very hot weather or a long period of uphill driving, the pointer may rise to the upper zone. If it reaches the red (hot) mark, pull safely to the side of the road. See page [231](#) for instructions and precautions on checking the engine's cooling system.

Outside Temperature Indicator

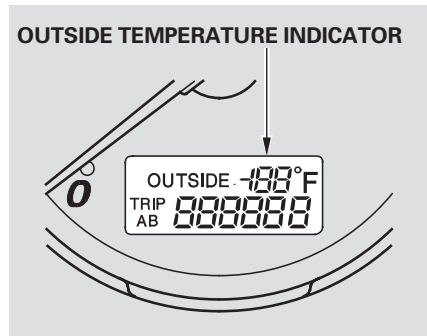

If equipped

This indicator displays the outside temperature in Fahrenheit (U.S. models) or Centigrade (Canadian models).

The temperature sensor is in the front bumper. Therefore, the temperature reading can be affected by heat reflection from the road surface, engine heat, and the exhaust from surrounding traffic. This can cause an incorrect temperature reading when your speed is under 19 mph (30 km/h).

The sensor delays the display update until it reaches the correct outside temperature. This may take several minutes.

If the outside temperature is incorrectly displayed, you can adjust it up $\pm 5^{\circ}\text{F}$ in U.S. models ($\pm 3^{\circ}\text{C}$ in Canadian models) warmer or cooler.

NOTE: The temperature must be stabilized before doing this procedure.

To adjust the outside temperature display, press and hold the Select/Reset button for 10 seconds. The following sequence will appear for one second each: 0, 1, 2, 3, 4, 5, -5, -4, -3, -2, -1, 0 (U.S.) or 0, 1, 2, 3, -3, -2, -1, 0 (Canada).

When it reaches the desired value, release the Select/Reset button. You should see the new outside temperature displayed.

In certain weather conditions, temperature readings near freezing (32°F , 0°C) could mean that ice is forming on the road surface.

Check Fuel Cap Indicator

If your fuel fill cap is loose or missing, a “CHECK FUEL CAP” message appears as text in the odometer/trip meter display after you start the engine. The message appears from CHECK to FUEL, then to CAP repeatedly.

Turn the engine off and confirm the fuel fill cap is installed. If it is, loosen the cap, then retighten it until it clicks at least once. When you restart the engine, the message appears again. To clear, press and hold the Select/Reset button until the message is replaced by the odometer/trip meter display.

If the system still detects a loose or missing fuel fill cap, the malfunction indicator lamp (MIL) comes on. Turn the engine off, and check or retighten the fuel fill cap until it clicks at least once. The MIL goes out after 3 days of normal driving once the cap is tightened or replaced. If it does not go out, have your dealer inspect the vehicle. For more information, see page [234](#).

Controls Near the Steering Wheel

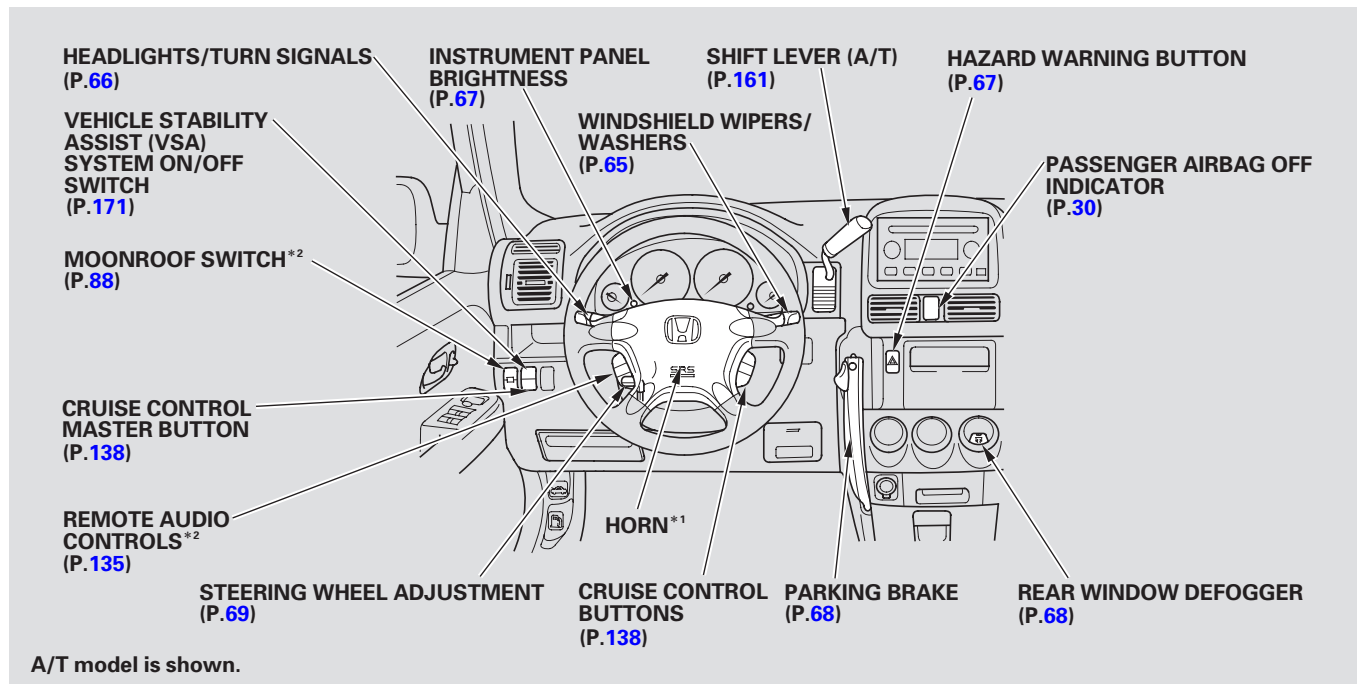

* 1 : To use the horn, press the center pad of the steering wheel.

* 2 : If equipped.

Windshield Wiper

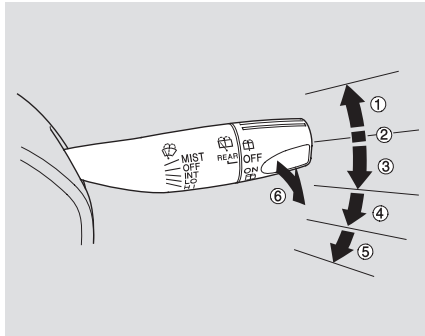

1. MIST
2. OFF
3. INT — Intermittent
4. LO — Low speed
5. HI — High speed
6. Windshield washers

Push the right lever up or down to select a position.

MIST — The wipers run at high speed until you release the lever.

OFF — The wipers are not activated.

INT — The wipers operate every few seconds.

LO — The wipers run at low speed.

HI — The wipers run at high speed.

Windshield Washers — Pull the wiper control lever toward you, and hold it. The washers spray until you release the lever. The wipers run at low speed, then complete one more sweep after you release the lever.

Rear Window Wiper and Washer

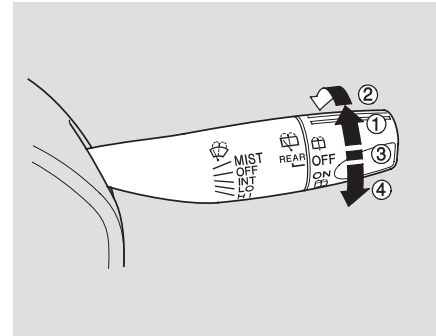

1. Rotate the switch clockwise to turn the rear window wiper ON. The wiper operates every 7 seconds after completing two sweeps.
2. Hold past ON to turn the rear window wiper on and to spray the rear window washer.

CONTINUED

Windshield Wipers and Washers, Turn Signal and Headlights

3. OFF

When you turn the wiper switch to the “OFF” position or turn off the ignition switch, the wiper will return to its parked position.

4. Rotate the switch counterclockwise to turn the window wiper on and the window washer to spray.

The rear wiper will not work if the hatch glass is not fully closed.

If you open the hatch glass while the rear wiper is operating, the wiper will stop. To return the wiper to its parked position, close the hatch glass, and then rotate the switch to the “OFF” position.

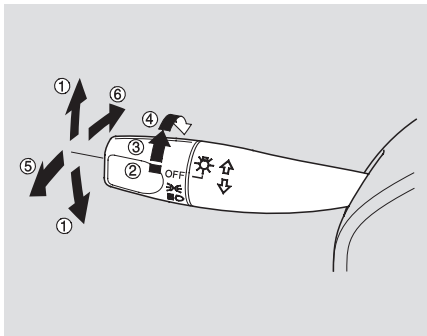

The rear window washer uses the same fluid reservoir as the windshield washer.

Turn Signal and Headlights



1. Turn signal
2. Off
3. Parking and interior lights
4. Headlights
5. High beams
6. Flash high beams

Turn Signal — Push down on the left lever to signal a left turn and up to signal a right turn. To signal a lane change, push lightly on the lever, and hold it. The lever will return to center when you release it or complete a turn.

Headlights — Turning the switch to the “ ” position turns on the parking lights, taillights, instrument panel lights, side-marker lights, and rear license plate lights. Turning the switch to the “ ” position turns on the headlights. If you leave the lights on with the key removed from the ignition switch, you will hear a reminder tone when you open the driver’s door.

High Beams — To turn on high beams, push the lever forward until you hear a click. The blue high beam indicator will come on (see page 59). Pull the lever back to return to the low beams.

To flash the high beams, pull the lever back lightly, then release it. The high beams will stay on as long as you hold the lever back.

Daytime Running Lights

Canadian models only

With the headlight switch off, the high beam headlights and the high beam indicator come on with reduced brightness when you turn the ignition switch to the ON (II) position and release the parking brake. They remain on until you turn the ignition switch off, even if you set the parking brake. The headlights revert to normal operation when you turn the switch to the “ ” position.

Instrument Panel Brightness

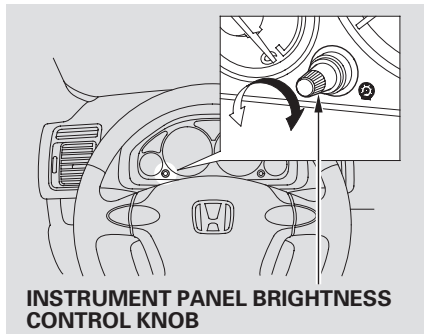

Turn the knob on the left side of the instrument panel to adjust the brightness of the instrument panel lights.

Hazard Warning Button

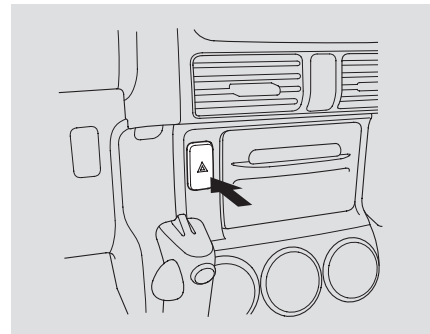

Push the button below the center vents to turn on the hazard warning lights (four-way flashers). This causes all four outside turn signals and both turn indicators in the instrument panel to flash. Use the hazard warning lights if you need to park in a dangerous area near heavy traffic, or if your vehicle is disabled.

Rear Window Defogger, Parking Brake

Rear Window Defogger

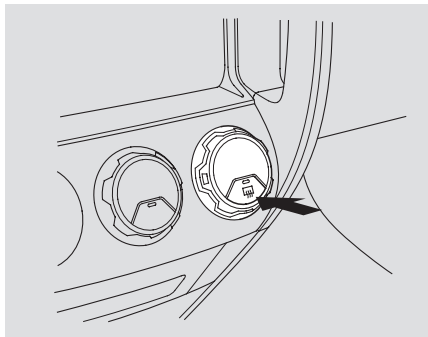

The rear window defogger will clear fog, frost, and thin ice from the window. Push the defogger button to turn it on and off. The indicator in the button comes on to show the defogger is on. It also shuts off when you turn off the ignition switch. You have to turn the defogger on again when you restart the vehicle.

Make sure the rear window is clear and you have good visibility before starting to drive.

The defogger wires on the inside of the rear window can be accidentally damaged. When cleaning the glass, always wipe side-to-side.

Parking Brake

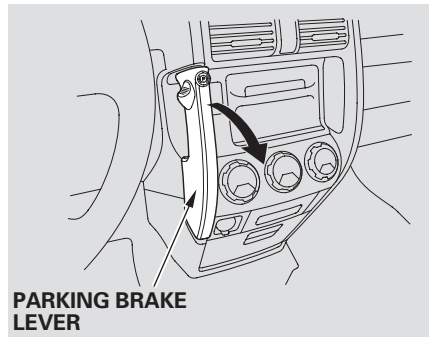

To apply the parking brake, firmly pull the parking brake lever toward you.

NOTICE

Driving the vehicle with the parking brake applied can damage the rear brakes and axles.

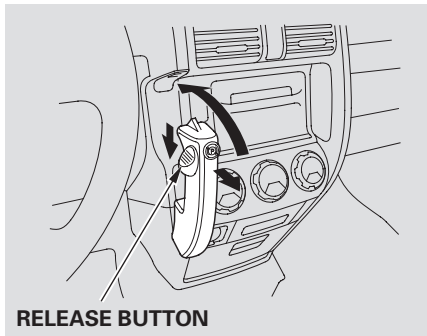

To release the parking brake, push and hold the release button on the side of the parking brake lever, pull the lever toward you slightly, then push the lever forward.

The parking brake indicator on the instrument panel should go out when the parking brake is fully released with the engine running (see page 56).

Steering Wheel Adjustment

Make any steering wheel adjustment before you start driving.

⚠ WARNING

Adjusting the steering wheel position while driving may cause you to lose control of the vehicle and be seriously injured in a crash.

Adjust the steering wheel only when the vehicle is stopped.

1. Push the lever under the steering column all the way down.
2. Move the steering wheel so it points toward your chest, not toward your face. Make sure you can see the instrument panel gauges and indicators.

CONTINUED

Steering Wheel Adjustment, Keys and Locks

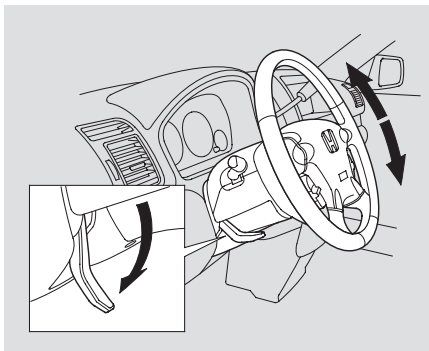

3. Push the lever up to lock the steering wheel in position.
4. Make sure you have securely locked the steering wheel in place by trying to move it up and down.

Keys and Locks

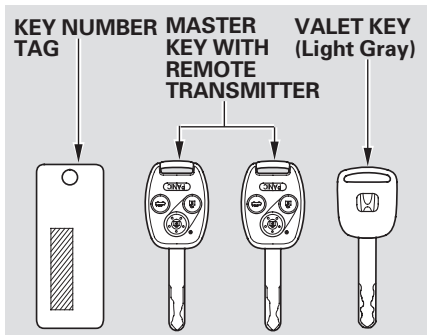

The master key fits all the locks on your vehicle. The valet key works only in the ignition, the door locks, and the tailgate. You can keep the glove box locked when you leave your vehicle and the valet key at a parking facility.

You should have received a key number tag with your keys. You will need this key number if you ever have to get a lost key replaced. Use only Honda-approved key blanks.

These keys contain electronic circuits that are activated by the immobilizer system. They will not work to start the engine if the circuits are damaged.

- Protect the keys from direct sunlight, high temperature, and high humidity.
- Do not drop the keys or set heavy objects on them.
- Keep the keys away from liquids. If they get wet, dry them immediately with a soft cloth.

The Immobilizer System protects your vehicle from theft. If an improperly-coded key (or other device) is used, the engine's fuel system is disabled.

When you turn the ignition switch to the ON (II) position, the immobilizer system indicator should come on for a few seconds, then go out. If the indicator starts to blink, it means the system does not recognize the coding of the key. Turn the ignition switch to the LOCK (0) position, remove the key, reinsert it, and turn the ignition switch to the ON (II) position again.

The system may not recognize your key's coding if another immobilizer key or other metal object (i.e. key fob) is near the ignition switch when you insert the key.

If the system repeatedly does not recognize the coding of your key, contact your dealer.

Do not attempt to alter this system or add other devices to it. Electrical problems could result that may make your vehicle undriveable.

If you have lost your key and cannot start your engine, contact your dealer.

As required by the FCC:

This device complies with Part 15 of the FCC rules. Operation is subject to the following two conditions: (1) This device may not cause harmful interference, and (2) this device must accept any interference received, including interference that may cause undesired operation.

Changes or modifications not expressly approved by the party responsible for compliance could void the user's authority to operate the equipment.

This device complies with Industry Canada Standard RSS-210.

Operation is subject to the following two conditions: (1) this device may not cause interference, and (2) this device must accept any interference that may cause undesired operation of the device.

Ignition Switch

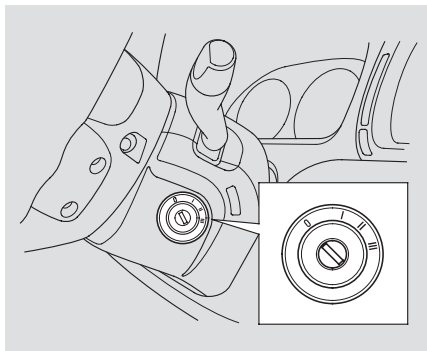

The ignition switch has four positions: LOCK (0), ACCESSORY (I), ON (II), and START (III).

LOCK (0) — You can insert or remove the key only in this position. To turn the key, push it in slightly. If your vehicle has an automatic transmission, the shift lever must also be in park.

If the front wheels are turned, the anti-theft lock may make it difficult to turn the key. Firmly turn the steering wheel to the left or right as you turn the key.

ACCESSORY (I) — You can operate the audio system and the accessory power socket in this position.

ON (II) — This is the normal key position when driving. Several of the indicators on the instrument panel come on as a test when you turn the ignition switch from the ACCESSORY (I) to the ON (II) position.

START (III) — Use this position only to start the engine. The switch returns to the ON (II) position when you let go of the key.

You will hear a reminder beeper if you leave the key in the LOCK (0) or the ACCESSORY (I) position and open the driver's door. Remove the key to turn off the beeper.

If your vehicle has an automatic transmission, the shift lever must be in Park before you can remove the key from the ignition switch.

⚠ WARNING

Removing the key from the ignition switch while driving locks the steering. This can cause you to lose control.

Remove the key from the ignition switch only when parked.

Power Door Locks

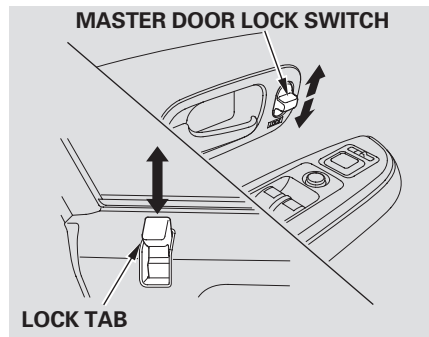

To lock the doors and the tailgate, press the master door lock switch on either front door, press the lock tab down on the driver's door, or use the key on the outside lock on the driver's door.

Pressing up on either master door lock switch will unlock all of the doors and the tailgate.

The lock tab on any door locks and unlocks that door. Pulling up on the driver's door lock tab only unlocks the driver's door.

To lock any passenger's door when getting out of the vehicle, push the lock tab down, and close the door. To lock the driver's door, remove the key from the ignition switch, pull the outside door handle and push the lock tab down or push the door lock switch down. Release the handle, then close the door.

Only the driver's door unlocks when you use the key on the outside driver's door lock.

Childproof Door Locks

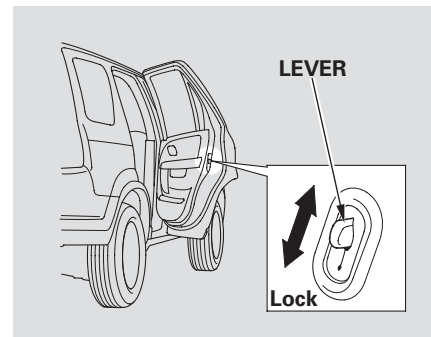

The childproof door locks are designed to prevent children seated in the rear from accidentally opening the rear doors. Each rear door has a lock lever near the edge. With the lever in the LOCK position, the door cannot be opened from the inside regardless of the position of the lock tab. To open the door, pull the lock tab up, and use the outside door handle.

Tailgate and Hatch Glass

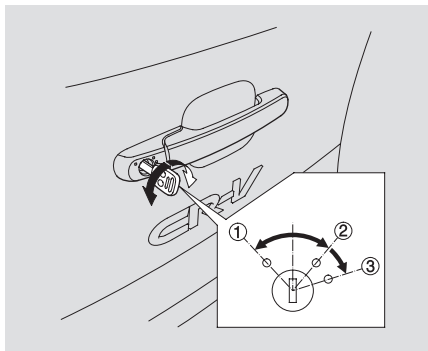

Use the valet or master key in the tailgate to:

1. **Unlock the tailgate.** Pull the handle to open it.
2. **Lock the tailgate.**
3. **Open the hatch glass.** You can also open it by pressing the hatch glass release button on the driver's door or on the remote transmitter.

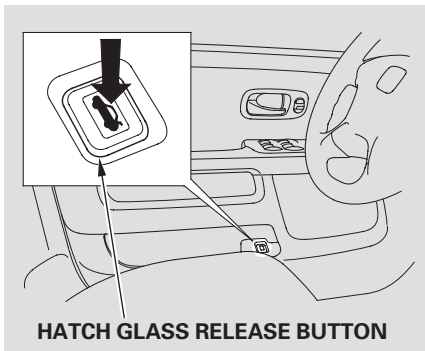

The rear wiper will not operate with the hatch glass open. If you open the hatch glass while the rear wiper is operating, the wiper will stop (see page 65).

To close the hatch glass, lower it and press on the handle until it latches.

You can also lock and unlock the tailgate with the remote transmitter, or either master door lock switch.

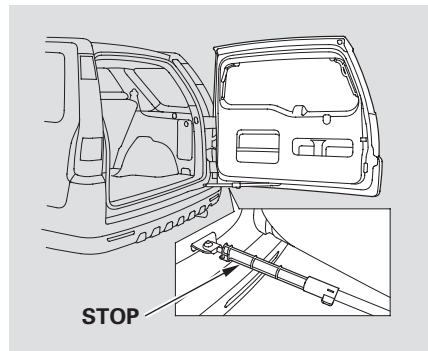

To keep the tailgate door open when facing downhill, use the stop from the tool kit.

The tool kit is in the storage bin under the cargo floor. Put the stop on the support strut as shown. Make sure to remove the stop before closing the tailgate.

Be sure all passengers or any objects are clear of the tailgate before opening or closing it.

Keep the tailgate and the hatch glass closed at all times while driving to avoid damaging the tailgate and the hatch glass, and to prevent exhaust gas from getting into the interior. See **Carbon Monoxide Hazard** on page 50.

Remote Transmitter

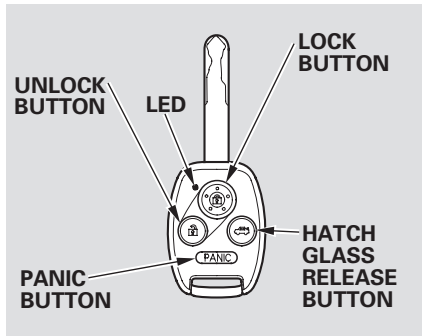

LOCK – Press this button once to lock all doors and the tailgate. Some exterior lights will flash once. When you push LOCK twice within 5 seconds, you will hear a beep to verify that the doors and the tailgate are locked. You cannot lock the doors and the tailgate if any door or the tailgate is not fully closed or the key is in the ignition switch.

UNLOCK – Press this button once to unlock the driver's door. Push it twice to unlock the other doors and the tailgate. Some exterior lights will flash twice each time you press the button.

The ceiling light (if the ceiling light switch is in the center position) will come on when you press the UNLOCK button. If you do not open any door or the tailgate within 30 seconds, the light fades out. If you relock the doors and the tailgate with the remote transmitter before 30 seconds have elapsed, the light will go off immediately.

If you do not open any door or the tailgate within 30 seconds, they will automatically relock.

CONTINUED

Remote Transmitter

HATCH GLASS RELEASE —

Press this button for about 1 second to open the hatch glass. You cannot open the hatch glass if the key is in the ignition switch. Even if the hatch glass is open, the tailgate can be locked with the remote transmitter.

PANIC — Press this button for about 2 seconds to attract attention: the horn will sound, and the exterior lights will flash for about 30 seconds. To cancel panic mode, press any other button on the remote transmitter, or turn the ignition switch to the ON (II) position.

Remote Transmitter Care

- Avoid dropping or throwing the transmitter.
- Protect the transmitter from extreme temperature.
- Do not immerse the transmitter in any liquid.
- If you lose a transmitter, the replacement needs to be reprogrammed by your dealer.

Replacing the Transmitter Battery

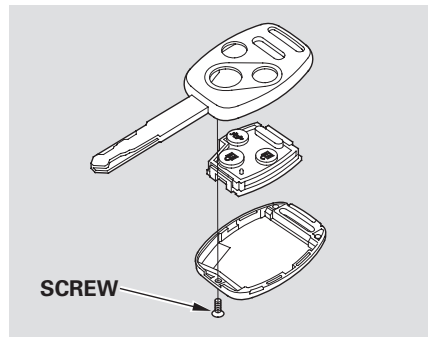

If it takes several pushes on the button to lock or unlock the doors and the tailgate, replace the battery as soon as possible.
Battery type: CR1616

To replace the battery:

1. Remove the screw at the base of the transmitter with a small Phillips-head screwdriver.

2. Separate the transmitter by prying its middle seam with your fingernail.

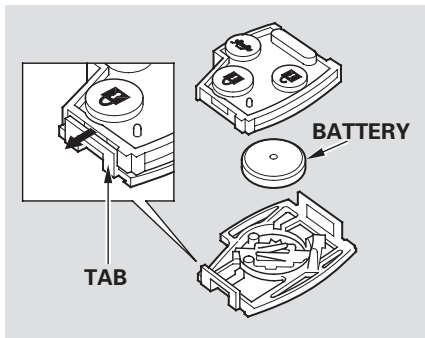

3. Inside the transmitter, separate the inner cover from the keypad by releasing the two tabs on the cover.

4. Remove the old battery, and insert a new battery into the back of the cover with the + side facing down.
5. Install the parts in reverse order.

As required by the FCC:

This device complies with Part 15 of the FCC rules. Operation is subject to the following two conditions: (1) This device may not cause harmful interference, and (2) this device must accept any interference received, including interference that may cause undesired operation.

Changes or modifications not expressly approved by the party responsible for compliance could void the user's authority to operate the equipment.

This device complies with Industry Canada Standard RSS-210.

Operation is subject to the following two conditions: (1) this device may not cause interference, and (2) this device must accept any interference that may cause undesired operation of the device.

Seats

Seat Adjustments

See pages 11 – 13 for important safety information and warnings about how to properly position the seats and seat-backs.

Make all seat adjustments before you start driving.

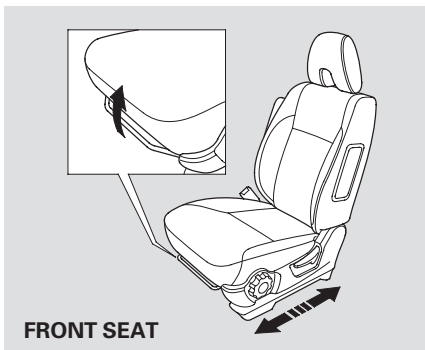

To adjust the front or rear seat forward and backward, pull up on the bar under the seat cushion's front edge. Try to move the seat to make sure it is locked in position.

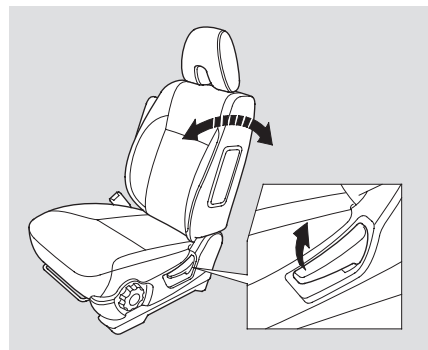

To change the seat-back angle of the front seat, pull up on the lever on the outside of the seat bottom.

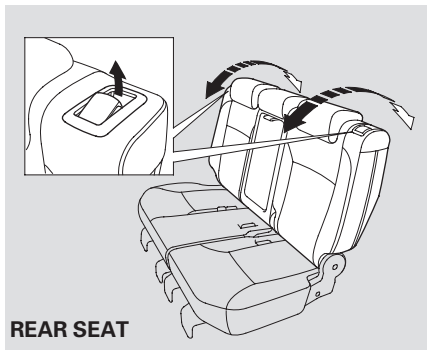

To change the angle of the rear seat-back, pull up on the release lever on the outside of the seat-back.

When using the center seating position, adjust the left and right side of the rear seats to the same position.

Make sure all rear shoulder belts are positioned in front of the rear seat-backs after you adjust the rear seats.

Driver's Seat Height Adjustment

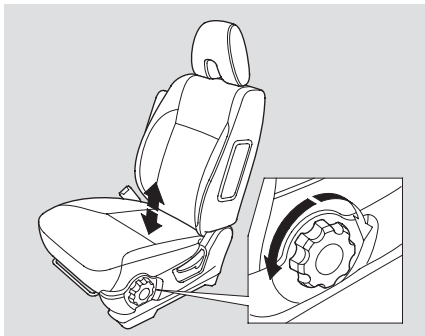

The height of the driver's seat is adjustable. Turn the dial on the outside of the seat cushion.

Armrests

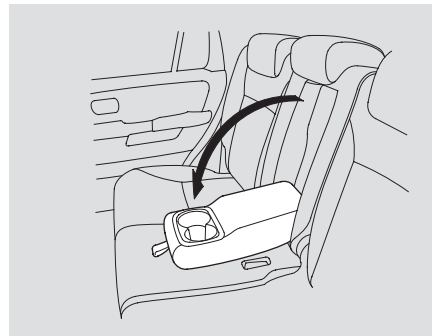

The rear seat armrest is in the center of the rear seat. Pivot it down to use it.

Only on vehicles with an automatic transmission

Each front seat has an armrest on the side of the seat-back. To use it, pivot it down.

Head Restraints

See page 13 for important safety information and a warning about how to properly position the head restraints.

Your vehicle is equipped with head restraints in all seating positions to help protect you and your passengers from whiplash and other injuries.

They are most effective when you adjust them so the back of the occupant's head rests against the center of the restraint.

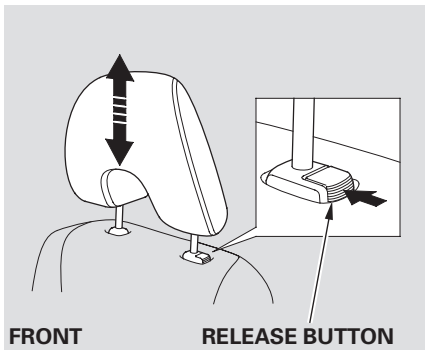

The head restraints adjust for height. You need both hands to adjust the restraint. Do not attempt to adjust it while driving. To raise it, pull upward. To lower the restraint, push the release button sideways, and push the restraint down.

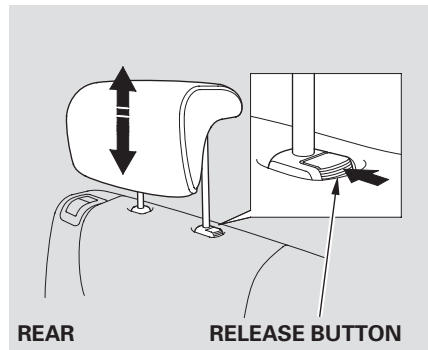

To remove a head restraint for cleaning or repair, pull it up as far as it will go. Push the release button, then pull the restraint out of the seat-back.

Make sure the removed head restraints are securely stored.

Reclining the Front Seats

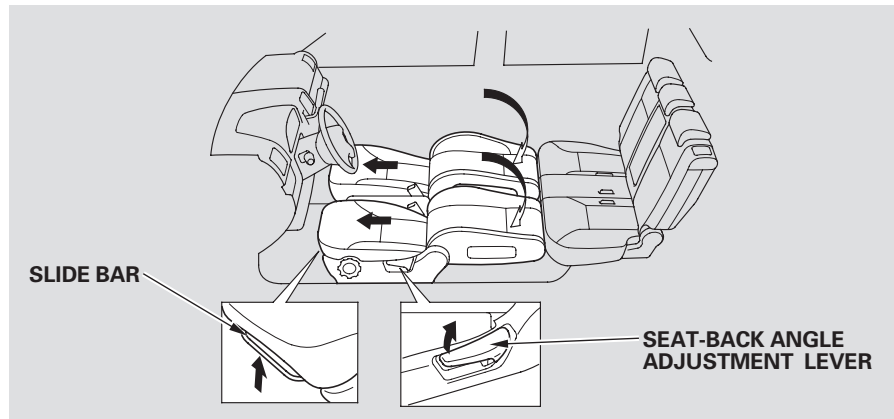

You can recline the seat-backs on the front seats so they are level with the rear seat cushions, making a large cushioned area. To do this:

1. Adjust the rear seats as far back as they will go.

2. Remove the head restraints from the front seats (see page 80). Make sure the removed head restraints are securely stored.

3. Adjust the front seats forward as far as they will go. Pull up the seat-back angle adjustment lever and pivot the seat-back backward until it is level with the rear seat cushion.

4. Move the front seat backward until it touches the rear seat.

5. Adjust the rear seat-back to the desired position.

Reverse this procedure to return the front and rear seats to the upright position. Make sure you install the head restraints and securely lock the seats before driving.

When you return the seat-back to the upright position, hold the seat-back to keep it from going up too quickly.

Seats

Folding the Rear Seats Down

The rear seat-back can be folded down to give more cargo room. Each side folds down separately, so you can still carry a passenger in the rear seat.

You can also fold up each of the rear seats separately to create further cargo space (see page 83).

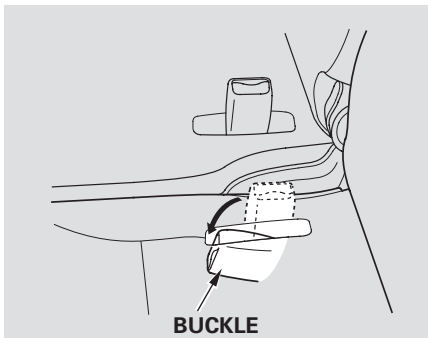

1. Push the seat belt buckles into the seat cushion.

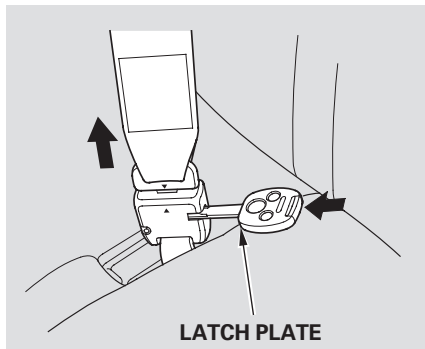

When you are folding the right half of the rear seat, use the key to release the center seat belt from the detachable anchor (see page 85). Allow the seat belt to retract into the holder on the ceiling and store the buckles in it.

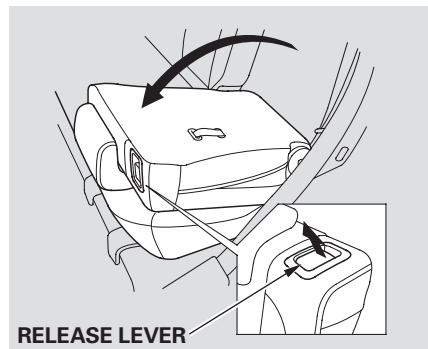

2. Lower the head restraint to its lowest position.
3. Pull up on the release lever on the outside of the seat-back.
4. Fold the seat-back forward.

Do not put any heavy items on the seat-back when it is folded.

Reverse this procedure to return the seat-back to the upright position. Make sure the seat is secured and the seat belt in front of the seat-back before driving.

Folding the Rear Seat Up

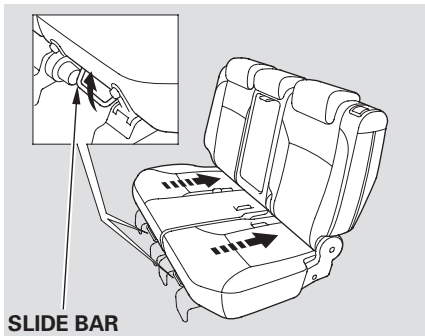

To fold up the rear seat:

1. Pull up the bar under the seat cushion and slide the rear seat backward. The rear seat will not fold up if it is not back as far as it will go.
2. Follow steps 1 through 4 on page 82 for folding down the seat-back.

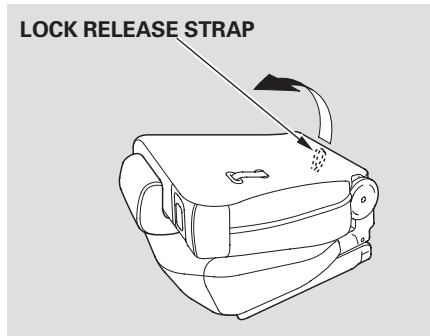

3. Unlock the seat from the floor by pulling the lock release strap under the seat cushion's back edge, then lift the rear of the seat. You cannot fold up the rear seat if it is not latched securely in the rearmost position.
4. Slide the seat forward.

CONTINUED

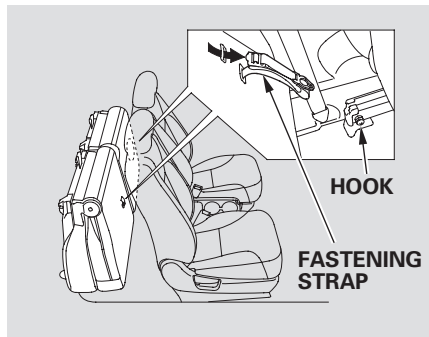

5. Pull out the fastening strap from the slit on the seat-back. Move the front seat forward slightly, then attach the anchor on the fastening strap to the hook on the bottom of the front seat. Adjust the front seat to the desired position.
6. Pull the fastening strap tab toward the slit to tighten the strap, and make sure the seat is secure.

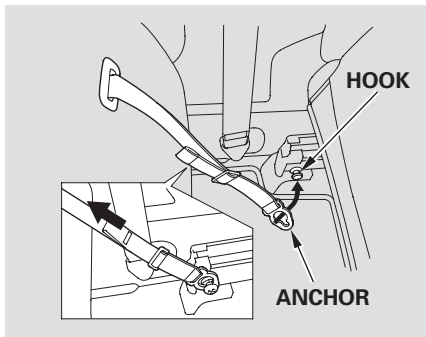

Make sure that the folded up rear seat does not interfere with the front passenger's seat-back. This will cause the front passenger's weight sensors to work improperly (see page 25). Also check the passenger airbag off indicator to assure proper operation of the passenger's advanced front airbag.

Reverse this procedure to return the seat to the upright position. Make sure the seat is securely latched before driving. When you are not using the fastening strap, roll up the strap and store it properly into the slit on the seat-back.

Make sure all rear shoulder belts are positioned in front of the rear seat-backs.

In the center seating position of the rear seat, be sure the detachable anchor is latched securely before using the seat belt (see page 85).

Make sure all items in the cargo area are secured. Loose items can fly forward and cause injury if you have to brake hard (See **Carrying Cargo** on page 150).

Detachable Anchor

The seat belt in the rear center seat is equipped with a detachable anchor. This allows the center seat belt to be unlatched when the right side of the rear seat is folded.

⚠ WARNING

Using a seat belt with the detachable anchor unlatched increases the chance of serious injury or death in a crash.

Before using the seat belt, make sure the detachable anchor is correctly latched.

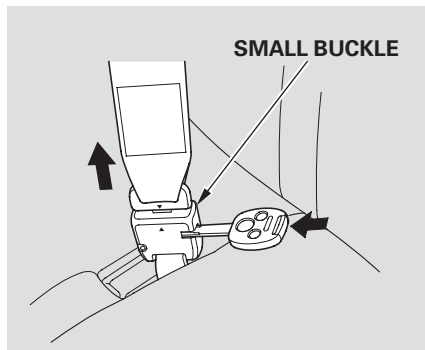

To unlatch the detachable anchor, insert a key into the slot on the side of the small buckle. Line up the triangle marks on the plate and buckle when reattaching the belt and buckle.

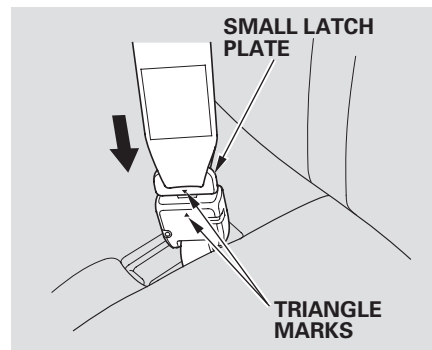

Line up the triangle marks on the small latch plate and buckle when reattaching the belt and buckle.

Tug on the seat belt to verify that the detachable anchor is securely latched. Make sure the seat belt is not twisted.

Seat Heaters, Power Windows

Seat Heaters

DRIVER'S SEAT HEATER SWITCH

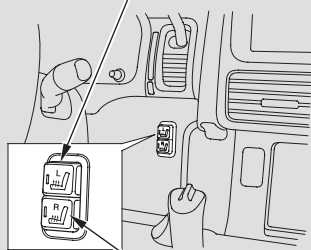

PASSENGER'S SEAT HEATER SWITCH

If equipped

Both front seats are equipped with seat heaters in the seat bottoms only. Because of sensors for the side airbag system, there are no heaters in the seat-back in either the driver or passenger seats. The ignition switch must be in the ON (II) position to use them. Push the heater switch to turn the power on or off. The indicators will come on and remain on while the heaters are on.

Do not use the seat heaters when the engine is off or when idling for a long period of time. They can drain the battery, making your vehicle hard to start.

Power Windows

DRIVER'S WINDOW SWITCH

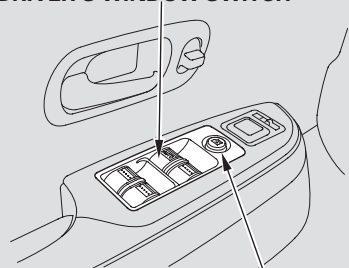

MAIN SWITCH

Turn the ignition switch to the ON (II) position to raise or lower any window. To open the window, push the switch down and hold it. Release the switch when you want to stop the window. Pull back on the switch and hold it to close the window.

⚠ WARNING

Closing a power window on someone's hands or fingers can cause serious injury.

Make sure your passengers are away from the windows before closing them.

AUTO — To open or close the driver's window, push or pull the window switch firmly down or up to the second detent, and release it. The window will automatically go up or down all the way. To stop the window, pull or push the window switch briefly.

When you push the MAIN switch in, the switch is OFF, and the passenger windows cannot be raised or lowered. To cancel this feature, push on the switch again to get it to pop out. Keep the MAIN switch off when you

have children in the vehicle so they do not injure themselves by operating the windows unintentionally.

AUTO REVERSE — If the driver's window senses any obstacle while it is closing automatically, it will reverse direction, and then stop. To close the window, remove the obstacle, then use the window switch again.

Auto reverse stops sensing when the window is almost closed. You should always check that all passengers and objects are away from the window before closing it.

If your vehicle's battery is disconnected or goes dead, or the driver's window fuse is removed, the AUTO function will be disabled. The power window system needs to be reset after reconnecting the battery or installing the fuse.

1. Start the engine. Push down and hold the driver's window switch until the window is fully open.
2. Pull and hold the driver's window switch to close the window completely, then hold the switch for about 2 seconds.

If the power windows do not operate properly after resetting, have your vehicle checked by your dealer.

Moonroof, Mirrors

Moonroof

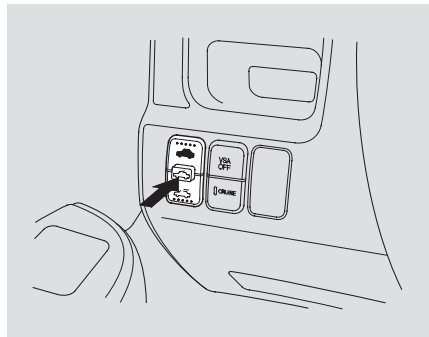

If equipped

Turn the ignition switch to the ON (II) position, and use the switch under the left dashboard vent to operate the moonroof.

To tilt up the back of the moonroof, press and hold the center button (☁).

To close the moonroof, press and hold the top of the switch (☀).

To open the moonroof, press and

hold the bottom of the switch (☁).

⚠ WARNING

Opening or closing the moonroof on someone's hands or fingers can cause serious injury.

Make sure all hands and fingers are clear of the moonroof before opening or closing it.

NOTICE

If you try to open the moonroof in below-freezing temperatures, or when it is covered with snow or ice, you can damage the moonroof panel or motor.

Mirrors

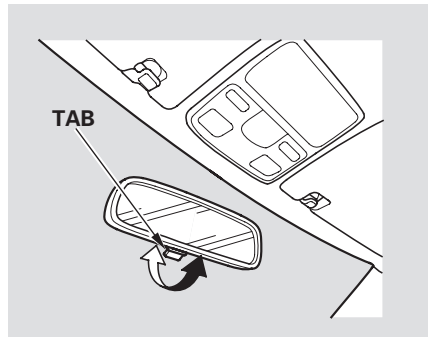

Keep the inside and outside mirrors clean and adjusted for best visibility. Be sure to adjust the mirrors before you start driving.

The inside mirror has day and night positions. The night position reduces glare from headlights behind you. Flip the tab on the bottom edge of the mirror to select the day or night position.

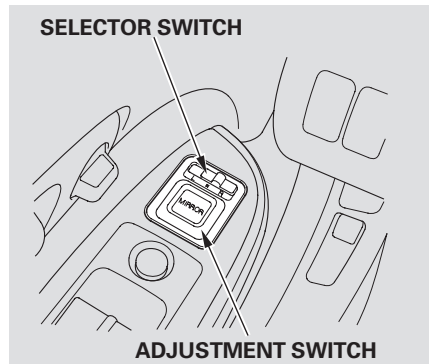
Adjusting the Power Mirrors

1. Turn the ignition switch to the ON (II) position.
2. Move the selector switch to L (driver's side) or R (passenger's side).

3. Push the appropriate edge of the adjustment switch to move the mirror right, left, up, or down.
4. When you finish, move the selector switch to the center (off) position. This turns the adjustment switch off to keep your settings.

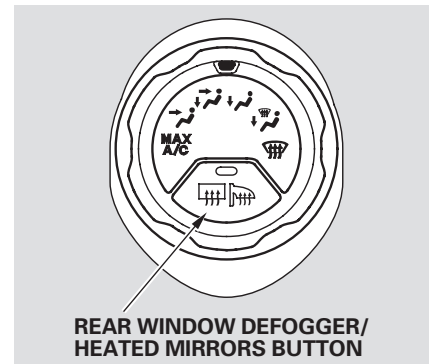
Power Mirror Heaters*If equipped*

The outside mirrors are heated to remove fog and frost. With the ignition switch in the ON (II) position, turn on the heaters by pressing the rear window defogger button. The indicator in the button comes on as a reminder. Press the button again to turn the heaters and the defogger off.

Interior Convenience Items

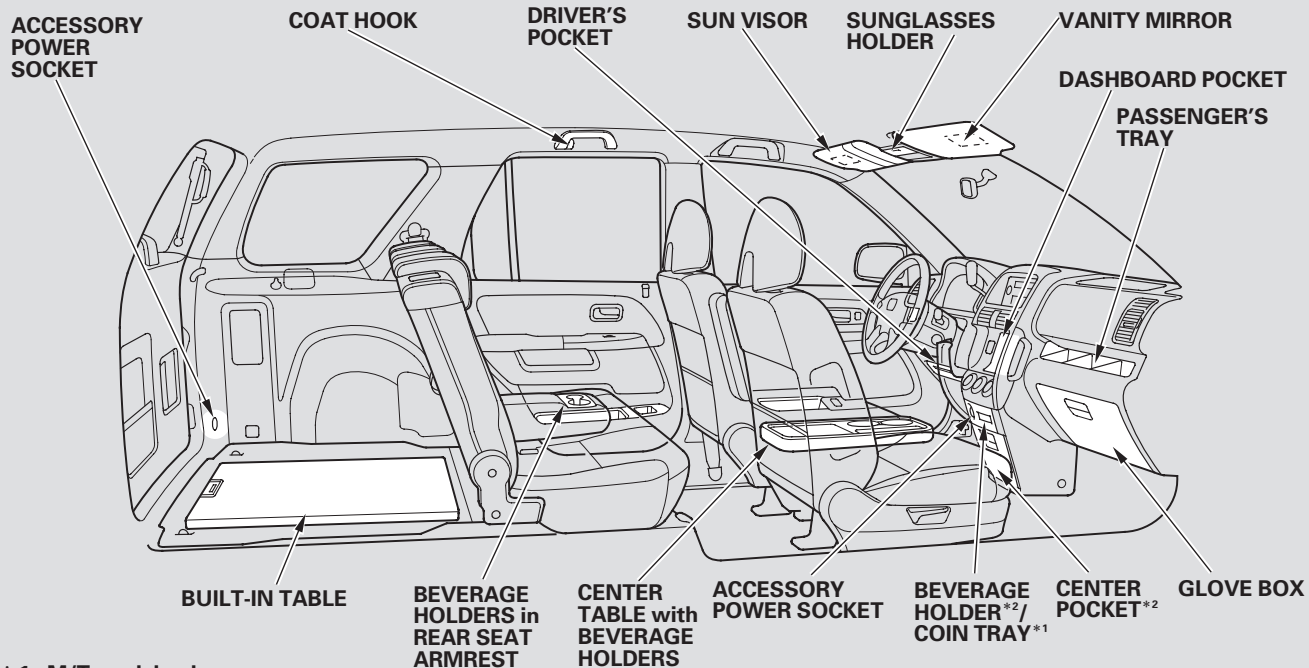

* 1 : M/T model only

* 2 : A/T model only

Beverage Holders

Be careful when you are using the beverage holders. Spilled liquid that is very hot can scald you or your passengers. Spilled liquids can also damage the upholstery, carpeting, and electrical components in the interior.

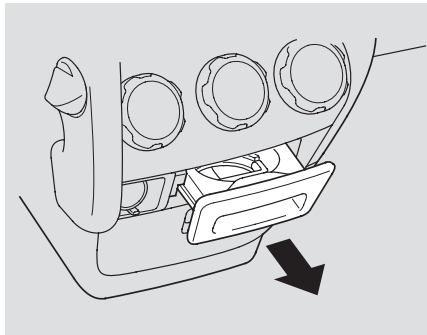

Only on models with an automatic transmission

To use the front beverage holder, pull on the handle.

Built-in Table

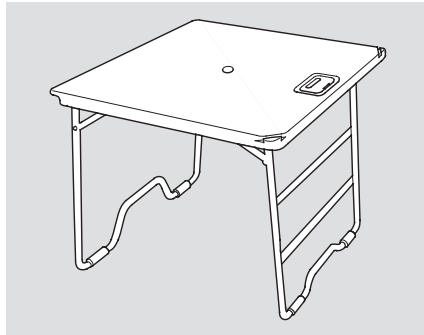

The cargo area floor can be taken out and used as a table.

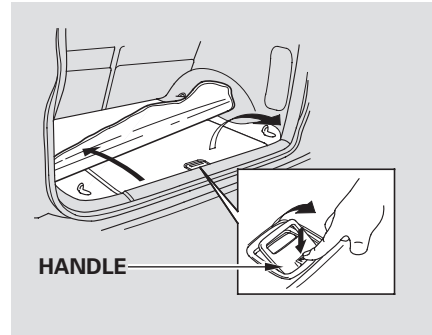

To remove the table, pull up the carpet. Lift and pull on the handle to slide the table out.

CONTINUED

Interior Convenience Items

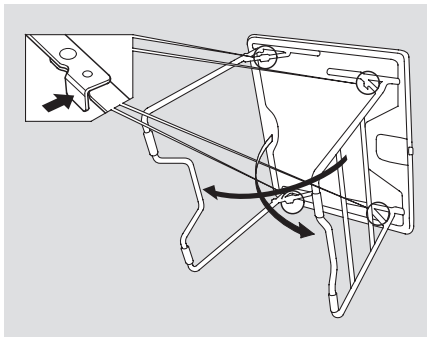

Unfold the legs. Lock them in place by pushing on the middle of the locking arms. Make sure all four are locked.

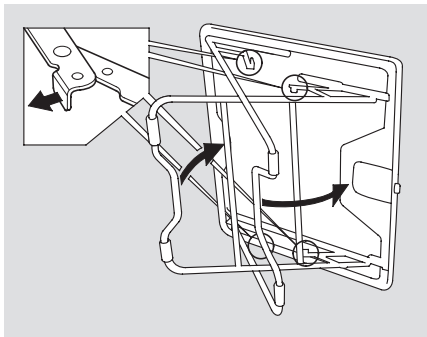

To fold the legs, pull on the middle of each locking arm.

To put the table back in place, hold onto the handle and put the projection on the table into the hole in the cargo area floor.

Using the Built-in Table

- Be sure to lock the legs of the table.
- Do not sit or stand on the table.
- Do not put a weight of over 44 lbs (20 kg) on the table.
- Hot items such as pots, pans, or kettles should not be placed directly on the tabletop.

Glove Box

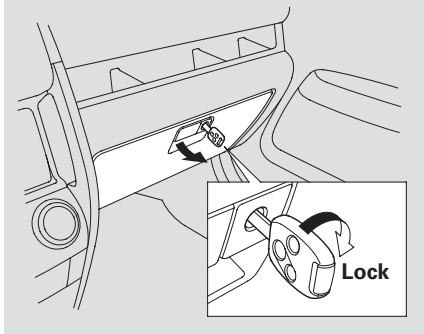

Open the glove box by pulling the bottom of the handle. Close it with a firm push. Lock or unlock the glove box with the master key.

The glove box light comes on only when the parking lights are on.

⚠ WARNING

An open glove box can cause serious injury to your passenger in a crash, even if the passenger is wearing the seat belt.

Always keep the glove box closed while driving.

Coin Tray

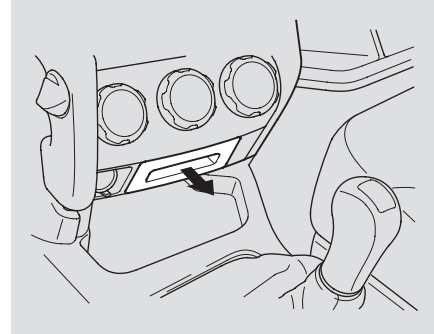

Only on models with a manual transmission

To open the coin tray, pull on the bottom edge. The light in the tray comes on when the parking lights are on.

Interior Convenience Items

Sunglasses Holder

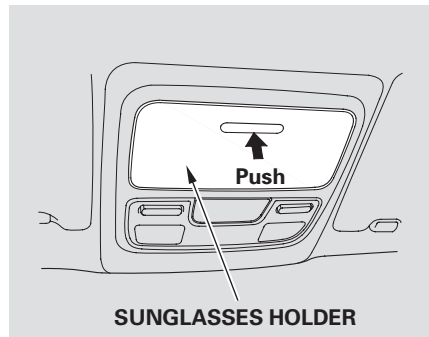

To open the sunglasses holder, push on the front edge. Make sure the holder is closed while you are driving.

Some larger styles of sunglasses may not fit in the holder.

Center Table

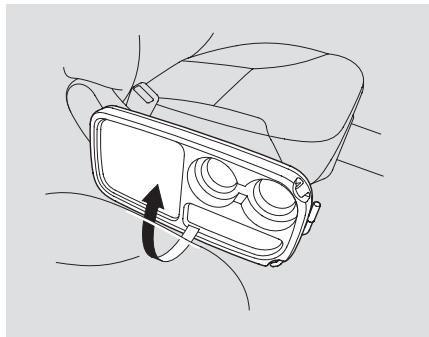

To use the center table, pull up the outside edge of the table until it latches. To store it, pull the lever and lower the table.

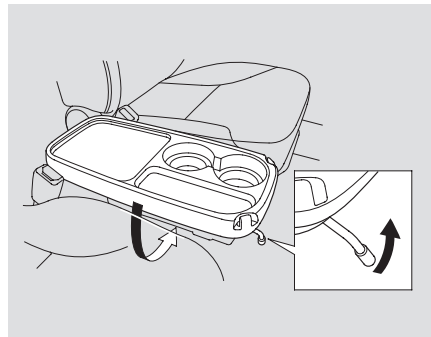

Sitting on or getting under the table, or putting heavy objects on the table, may damage or deform it.

Do not put any items on the table while driving. They may fall down or fly around when you go around corners or brake hard.

Accessory Power Sockets

These sockets are intended to supply power for 12 volt DC accessories that are rated 120 watts or less (10 amps).

To use an accessory power socket, the ignition switch must be in the ACCESSORY (I) or ON (II) position.

None of the sockets will power an automotive type cigarette lighter element. When more than one socket is being used, the combined power rating of the accessories should be 120 watts or less (10 amps).

Center Pocket

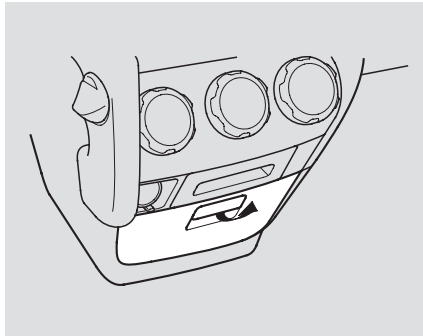

Only on models with an automatic transmission

Open the center pocket by pulling the handle.

Sun Visor

To use the sun visor, pull it down. When using the sun visor for the side window, remove the support rod from the clip, and swing it out.

Ceiling Light

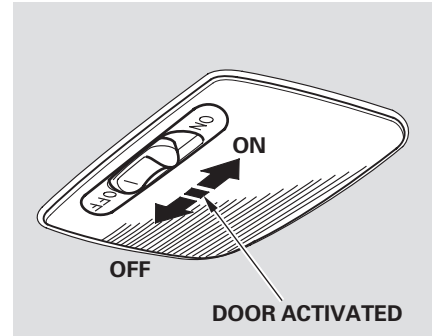

The ceiling light has a three-position switch; ON, Door Activated, and OFF. In the Door Activated (center) position, the light comes on when you:

- Open any door.
- Unlock the doors and the tailgate with the key or remote transmitter.

CONTINUED

Interior Lights

After all doors are closed tightly, the light fades out in about 30 seconds.

The ceiling light (with the switch in the center position) comes on when you remove the key from the ignition switch. If you do not open a door, the light fades out in about 30 seconds.

If you leave any door or the tailgate open with the key not in the ignition switch, the ceiling light will go off after 3 minutes.

Spotlights

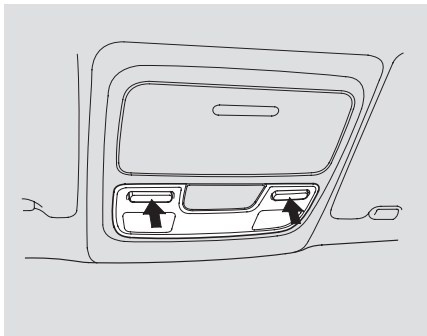

Turn on the spotlight by pushing the button. Push the button again to turn it off. You can use the spotlights at all times.

Ignition Switch Light

The ignition switch light comes on when you open the driver's door. It fades out in about 30 seconds after the door is closed.

Cargo Area Light

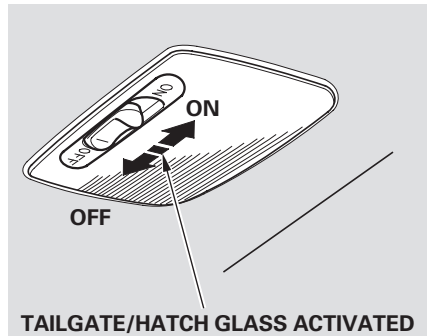

The cargo area light has a three-position switch. In the OFF position, the light does not come on. In the center position, the light comes on when you open the tailgate or the hatch glass. In the ON position, the light stays on continuously.

The heating and air conditioning system in your vehicle provides a comfortable driving environment in all weather conditions.

The standard audio system has many features. This section describes those features and how to use them.

Your vehicle has an anti-theft audio system that requires a code number to enable it.

Vents, Heating, and A/C	98
Audio System	103
Playing the Radio.....	105, 116
Playing a Disc.....	109, 124
Disc Changer	111, 125
Disc Player/Changer Error Messages.....	112, 128
Playing a Tape.....	113, 129
Caring for the Tape and Player	115, 131
Playing the XM [®] Satellite Radio ..	120
Radio Reception	132
Protecting Your Discs.....	134
Remote Audio Controls.....	135
Radio Theft Protection.....	136
Setting the Clock	137
Cruise Control.....	138

Vents, Heating, and A/C

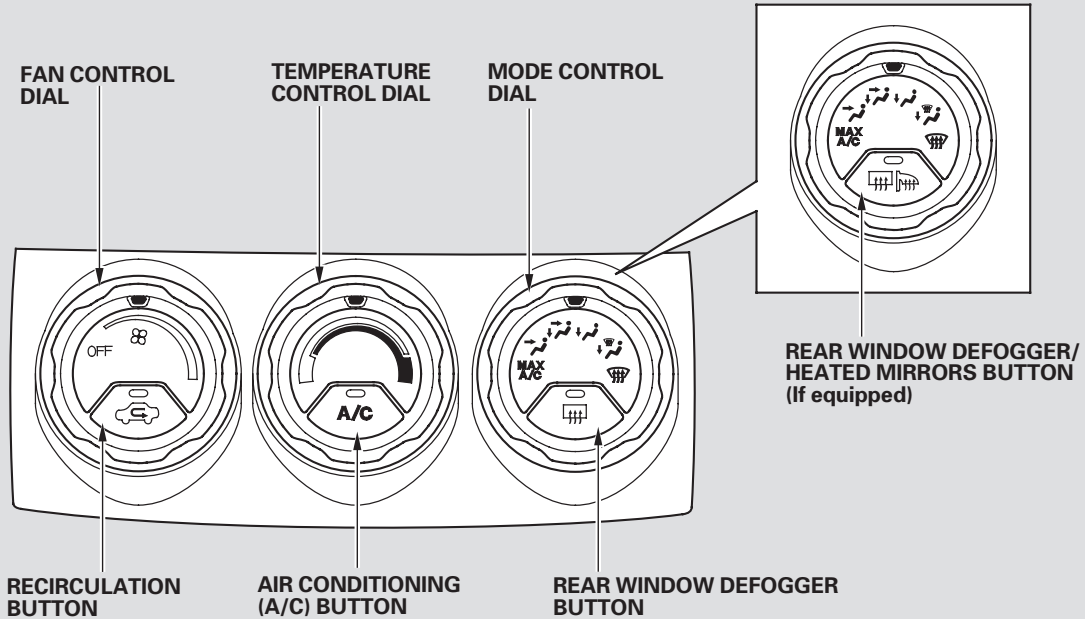

Air Flow Buttons

Fan Control Dial

Turn this dial to increase or decrease the fan speed and airflow.

Temperature Control Dial

Turning this dial clockwise increases the temperature of the airflow.

Air Conditioning (A/C) Button

This button turns the air conditioning on and off. The indicator in the button is on when the A/C is on.

Recirculation Button

When the recirculation indicator is on, air from the vehicle's interior is sent throughout the system again. When the indicator is off, air is brought in from the outside of the vehicle (fresh air mode).

The outside air intakes for the heating and cooling system are at the base of the windshield. Keep this area clear of leaves and other debris.

The system should be left in fresh air mode under almost all conditions. Keeping the system in recirculation mode, particularly with the A/C off, can cause the windows to fog up.

Switch to recirculation mode when driving through dusty or smoky conditions, then return to fresh air mode.

Rear Window Defogger Button

This button turns the rear window defogger off and on (see page 68).

On some models, this button also controls the heated mirror function (see page 89).

Mode Control Dial

Use the mode control dial to select the vents the air flows from. Some air will flow from the dashboard corner vents in all modes.

MAX A/C

The system automatically turns on the A/C and switches to recirculation mode. Air flows from the center and side vents in the dashboard.



Air flows from the center and corner vents in the dashboard.



Airflow is divided between the vents in the dashboard and the floor vents.





Air flows from the floor vents. When you select , the system automatically switches to fresh air mode.

CONTINUED

Vents, Heating, and A/C

 Airflow is divided between the floor vents and the defroster vents at the base of the windshield.

 Air flows from the defroster vents at the base of the windshield.

When you select  or  , the system automatically switches to fresh air mode and turns on the A/C. In this case, you cannot turn the A/C off.



Ventilation

The flow-through ventilation system draws in outside air, circulates it through the interior, then exhausts it through vents near the tailgate.

1. Set the temperature to the lower limit.
2. Make sure the A/C is off.
3. Select  and fresh air mode.
4. Set the fan to the desired speed.

Using the Heater

The heater uses engine coolant to warm the air. If the engine is cold, it will be several minutes before you feel warm air coming from the system.

1. Select  .
When you select  , the system automatically switches to fresh air mode.
2. Set the fan to the desired speed.
3. Adjust the warmth of the air with the temperature control dial.

Using the A/C

Air conditioning places an extra load on the engine. Watch the engine coolant temperature gauge (see page 62). If it moves near the red zone, turn off the A/C until the gauge reading returns to normal.

1. Turn on the A/C by pressing the button. The indicator in the button comes on when a fan speed is selected.
2. Make sure the temperature is set to maximum cool.
3. Select  .
4. If the outside air is humid, select recirculation mode. If the outside air is dry, select fresh air mode.
5. Set the fan to the desired speed.

To cool the interior with MAX A/C:

1. Set the fan to the desired speed.
2. Select MAX A/C mode.
The system automatically turns on the A/C, selects , and switches to recirculation mode.
3. Make sure the temperature is set to maximum cool.

If the interior is very warm, you can cool it down more rapidly by partially opening the windows, turning on the A/C, and setting the fan to maximum speed in fresh air mode.

To Dehumidify the Interior



Air conditioning, as it cools, removes moisture from the air. When used in combination with the heater, it makes the interior warm and dry.

1. Turn the fan on.
2. Turn on the air conditioning.
3. Select  and fresh air mode.
4. Adjust the temperature to your preference.



This setting is suitable for all driving conditions whenever the outside temperature is above 32°F (0°C).

To Defog and Defrost



To remove fog from the inside of the windows:

1. Set the fan to the desired speed or high for faster defrosting.
2. Select . The system automatically switches to fresh air mode and turns on the A/C. The A/C indicator will not come on, if it was previously off.
3. Adjust the temperature so the airflow feels warm.
4. Select  to help clear the rear window and the outside mirrors (if equipped).
5. To increase airflow to the windshield, close the corner vents.

Vents, Heating, and A/C

When you select  or , the system automatically switches to fresh air mode and turns on the A/C. This helps to dehumidify the air and to defog the windshield. In either mode, you cannot turn off the A/C. When you switch to another mode, the A/C returns to its original setting, either on or off, as displayed by the A/C indicator.

To Remove Exterior Frost or Ice From the Windows

1. Select . The system automatically switches to fresh air mode and turns on the A/C. The A/C indicator does not come on if it was previously off.
2. Select .
3. Set the fan and temperature controls to maximum level.

To clear the windows faster, you can close the dashboard corner vents by rotating the wheel below each vent. This sends more warm air to the windshield defroster vents. Once the windshield is clear, select fresh air mode to avoid fogging the windows.

For your safety, make sure you have a clear view through all the windows before driving.

To Turn Everything Off

Turning the fan speed control dial all the way to the left shuts the system off.

- Keep the system off for short periods only.
- To keep stale air and mustiness from collecting, you should have the fan running at all times.

Some models may have one of the audio systems described in this section. Read the appropriate pages in this section for operation of the audio systems installed in your vehicle.

- page 105 to 115 for U.S. LX model, Canadian SE model
- page 116 to 131 for U.S. EX, SE models, Canadian EX, EX-L models

If your vehicle has a different audio system refer to its manual for operating instructions.

U.S. LX and Canadian SE model

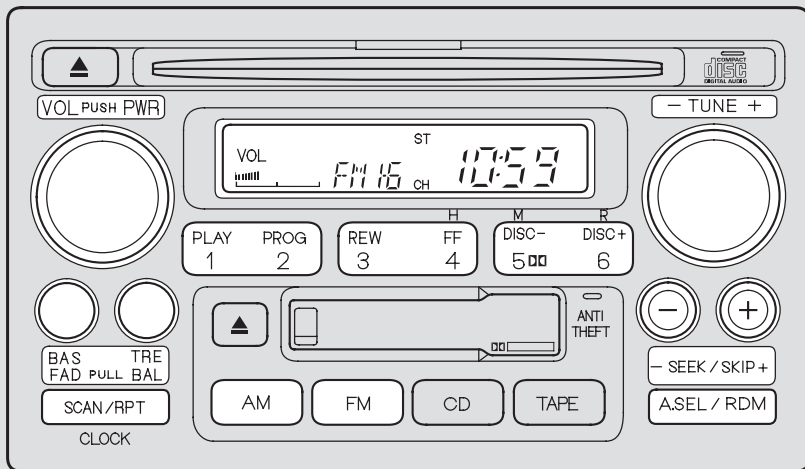

Canadian EX and EX-L models

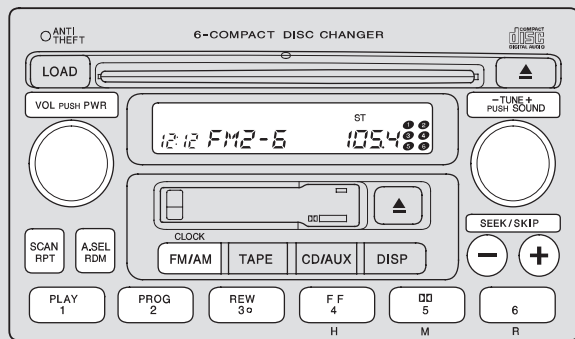

U.S. EX and SE models

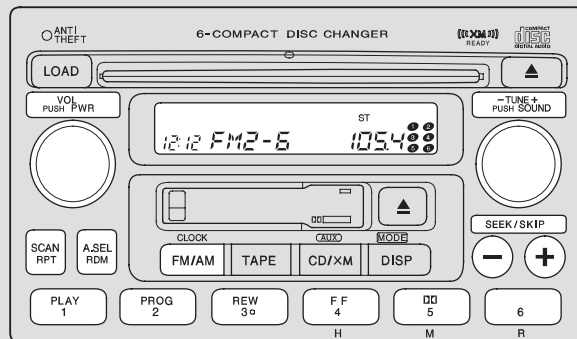

U.S. LX and Canadian SE model

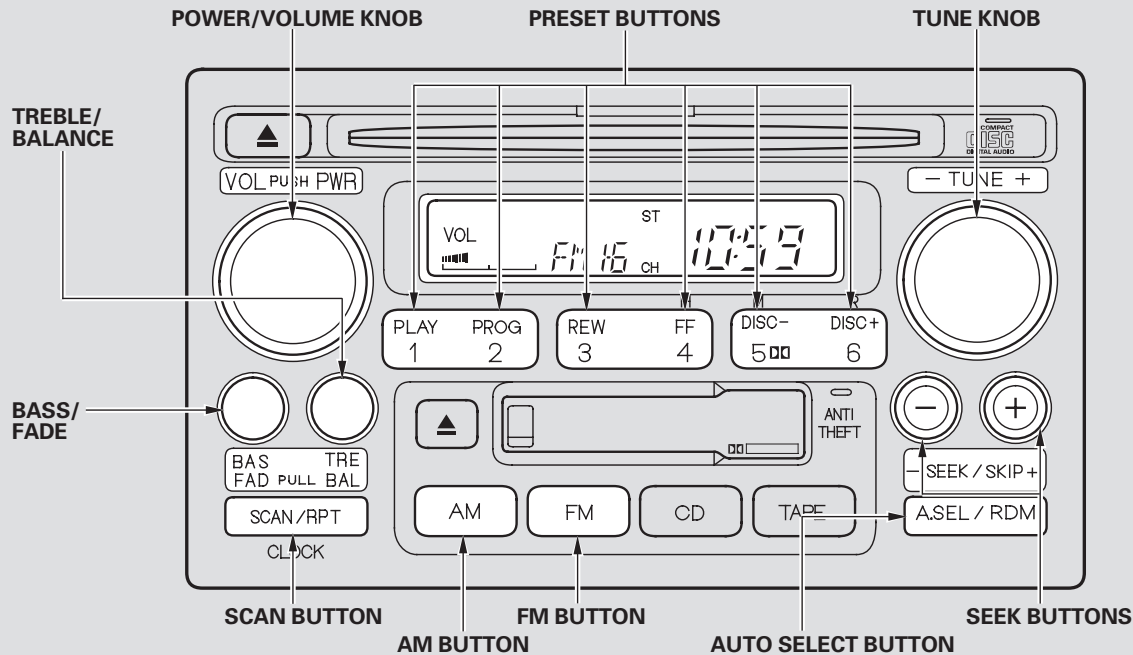

Playing the Radio

To Play the Radio

The ignition switch must be in the ACCESSORY (I) or ON (II) position. Turn the system on by pushing the PWR/VOL knob or the AM or FM button. Adjust the volume by turning the PWR/VOL knob.

The band and frequency that the radio was last tuned to is displayed. To change bands, press the AM or FM button. On the FM band, ST will be displayed if the station is broadcasting in stereo.

Stereo reproduction on AM is not available.

To Select a Station

You can use any of five methods to find radio stations on the selected band: **TUNE**, **SEEK**, **SCAN**, the preset buttons, and **AUTO SELECT**.

TUNE — Use the TUNE knob to tune the radio to a desired frequency. Turn the knob right to tune to a higher frequency, or left to tune to a lower frequency.

SEEK — The SEEK function searches up and down from the current frequency to find a station with a strong signal. To activate it, press the ⊕ or ⊖ SEEK button, then release it.

SCAN — The SCAN function samples all stations with strong signals on the selected band. To activate it, press the SCAN button, then release it. You will see SCAN in the display. The system will scan for a station with a strong signal. When it finds one, it will stop and play that station for about 10 seconds.

If you do nothing, the system will scan for the next strong station and play it for 10 seconds. When it plays a station that you want to listen to, press the SCAN button again.

Preset — Each preset button can store one frequency on AM and two frequencies on FM.

1. Select the desired band, AM or FM. FM1 and FM2 let you store two frequencies with each preset button.
2. Use the TUNE, SEEK, or SCAN function to tune the radio to a desired station.
3. Pick a preset button and hold it until you hear a beep.
4. Repeat steps 1 through 3 to store a total of six stations on AM and twelve stations on FM.

The preset frequencies will be lost if your vehicle's battery goes dead, is disconnected, or the radio fuse is removed.

AUTO SELECT — If you are traveling far from home and can no longer receive your preset stations, you can use the auto select feature to find stations in the local area.

Press the A. SEL button. "A.SEL" flashes in the display, and the system goes into scan mode for several seconds. It stores the frequencies of six AM and twelve FM stations in the preset buttons.

You will see a "0" displayed after pressing a preset button if auto select cannot find a strong station for every preset button.

If you do not like the stations auto select has stored, you can store other frequencies on the preset buttons as previously described.

To turn off auto select, press the A. SEL button. This restores the presets you originally set.

Playing the Radio

Adjusting the Sound

BAL — Adjust the balance or side-to-side strength of the sound.

FAD — Adjust the fader or the front-to-back strength of the sound.

TRE — Adjust the treble in the sound.

BAS — Adjust the bass in the sound.

BAS/FAD: Press the knob to pop it out. Turn it to adjust the Bass level. Pull it out slightly farther to adjust the Fade, or front-to-back strength. Push the knob back in when you are done adjusting the sound.

TRE/BAL: Press the knob to pop it out. Turn it to adjust the Treble level. Pull it out slightly farther to adjust the balance, or side-to-side strength. Push the knob back in when you are done adjusting the sound.

Audio System Lighting

You can use the instrument panel brightness control knob to adjust the illumination of the audio system (see page 67). The audio system illuminates when the parking lights are on, even if the radio is off.

Radio Frequencies and Reception

For information, see page 132 .

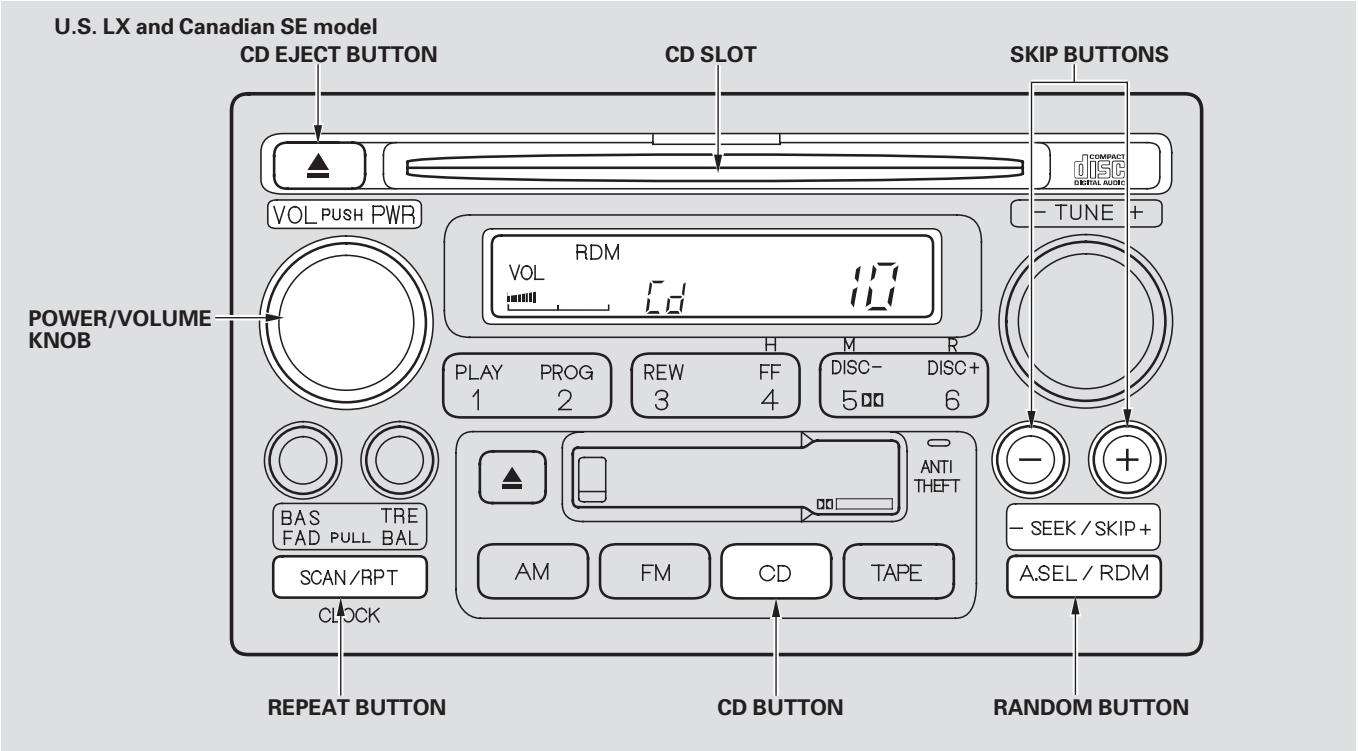

Playing a Disc

To Play a CD

To load or play CDs, the ignition switch must be in the ACCESSORY (I) or the ON (II) position.

You operate the CD player with the same controls used for the radio. To select the CD player, press the CD button. The number of the track playing is shown in the display. The system will continuously play a CD until you change modes.

Insert a CD into the CD slot. The drive will pull the CD in the rest of the way to play it. When the system reaches the end of the disc, it will return to the beginning and play the disc again.

You can also play 3-inch (8-cm) discs without using an adapter ring.

NOTICE

Do not use discs with adhesive labels. The label can curl up and cause the disc to jam in the unit.

To play the radio when a CD is playing, press the AM or FM button. Press the CD button again to switch back to the CD player.

To play the tape when a CD is playing, insert a tape in the player. If a tape is in the player, press the TAPE button. Press the CD button again to switch back to the CD player.

If you turn the system off while a CD is playing, either with the PWR/VOL knob or by turning off the ignition, the disc will stay in the drive. When you turn the system back on, the CD will begin playing where it left off.

To Change or Select Tracks

SKIP — Each time you press and release the ⊕ skip button, the player skips forward to the beginning of the next track. Press and release the ⊖ skip button, to skip backward to the beginning of the current track. Press it again to skip to the beginning of the previous track.

To move rapidly within a track, press and hold the ⊕ or ⊖ skip button.

REPEAT — To continuously replay a track, press and release the RPT button. You will see REPEAT in the display. Press it again to turn it off.

RANDOM — This feature plays the tracks in random order. To activate random play, press and release the RDM button. You will see RDM in the display. Press it again to return to normal play.

SCAN — The SCAN function samples all the tracks on the disc in the order they are recorded on the CD. To activate it, press and hold the SCAN button. You will see SCAN in the display. You will get a 10 second sampling of each track on the CD. Press the SCAN button again to get out of the system and play the last track sampled.

To Stop Playing a CD

Press the eject button () to remove the CD. If you eject the CD, but do not remove it from the slot, the system will automatically reload the CD after 10 seconds and put it in pause mode. To begin playing, press the CD button.

Press the AM or FM button to switch to the radio while a CD is playing. To play the CD, press the CD button.

If a tape is in the tape player, press the TAPE button to switch to the tape while a CD is playing. Press the CD button again to switch back to the CD player.

If you turn the system off while a CD is playing, either with the PWR/VOL knob or by turning off the ignition, the disc will stay in the drive. When you turn the system back on, the CD will begin playing where it left off.

Protecting Discs

For information on how to handle and protect discs, see page [134](#).

Operating Optional CD Changer

An optional six disc CD changer is available from your dealer. This disc changer uses the same controls used for the in-dash CD player or the radio.

Load the desired CDs in the magazine, and load the magazine in the changer according to the instructions that came with it.

To select the CD changer, press the CD button. The CD and track numbers will be displayed. To select a different CD, use the preset 5 (DISC -) button to select the previous disc, or the preset 6 (DISC +) button to select the next disc in sequence. If you select an empty slot in the magazine, the changer will search for the next available CD to load and play.

Disc Player/Changer Error Messages

If you see an error message in the display while playing a CD, find the cause in the chart to the right. If you cannot clear the error message, take the vehicle to your dealer.

CD Player

Error Message	Cause	Solution
<i>cd Err</i>	Mechanical Error	Press the CD eject button and pull out the CD. Check it for damage or deformation. If the CD cannot be pulled out, or the error message does not disappear after the CD is ejected, see your dealer.
<i>cd Hot</i>	High temperature	Will disappear when the temperature returns to normal.
<i>cd dISC</i>	Focus Error	Press the eject button and pull out the CD. Check if it is inserted correctly in the CD player. Make sure the CD is not scratched or damaged.

CD Changer

Error Message	Cause	Solution
<i>cdC Hot</i>	High temperature	Will disappear when the temperature returns to normal.
<i>cdC 0000</i>	No CD in magazine	Insert CDs in magazine.
<i>cdC dISC</i>	Focus Error	Press the CD eject button and pull out the CDs. Check for an error message, and insert the CDs again. If the message does not disappear or the CDs cannot be pulled out, see your dealer.
<i>cdC Err</i>	Mechanical Error	

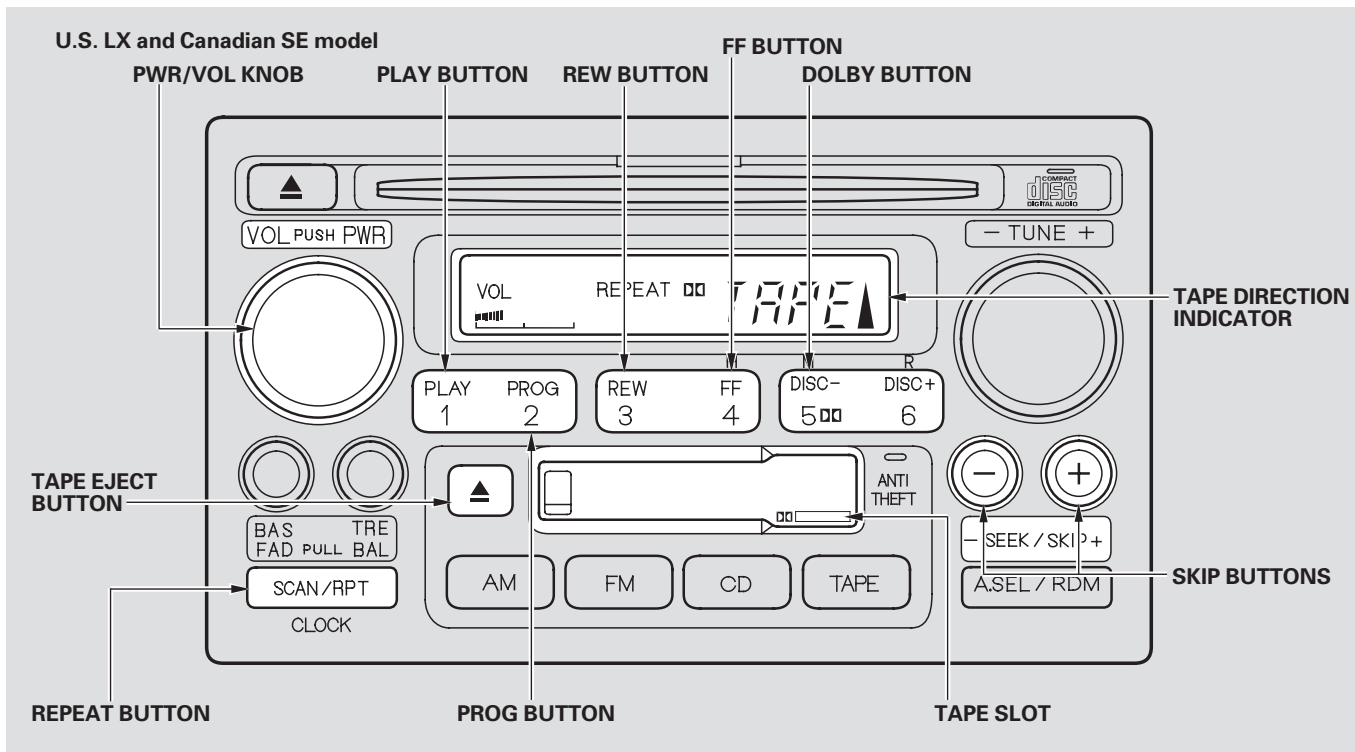





Playing a Tape

To Play a Tape

The ignition switch must be in the ACCESSORY (I) or the ON (II) position. Make sure the open side of the tape is facing right, then insert the tape most of the way into the slot. The system will pull the tape in the rest of the way and begin to play it.

The tape direction indicator in the display comes on to show you which side of the tape is playing. The ▲ indicates the side you inserted upward is now playing. If you want to play the other side, press the PROG button. When the player reaches the end of the tape, it will automatically reverse direction and play the other side.

Dolby* noise reduction turns on when you insert a tape. The  indicator will light in the display. If the tape was not recorded in Dolby, turn it off by pressing the  button. Dolby remains off until you press the  button again.

* Dolby noise reduction is manufactured under license from Dolby Laboratories Licensing Corporation. "DOLBY" and the double-D symbol  are trademarks of Dolby Laboratories Licensing Corporation.

To Stop Playing a Tape

To remove the tape, press the eject button. If you want to turn the player off, press the PWR/VOL knob or turn off the ignition. The tape will remain in the drive. When you turn the system back on, the tape will begin playing where it left off.

To switch to the radio or CD player while a tape is playing, press the AM, FM, or CD button. To change back to the tape player, press the TAPE button.

Tape Search Functions

FF/REW — To rewind the tape, push the REW button. You will see REW in the display. To fast forward the tape, push the FF button. You will see FF displayed. Press the FF, REW, or PLAY button to take the system out of rewind or fast forward.

SKIP — Press the ⊖ button to find the beginning of the current song or passage. Press the ⊕ button to find the beginning of the next song or passage. When the system reaches the beginning of a song or passage, it begins to play it.

REPEAT — Press the RPT button to continuously play a song or passage. You will see REPEAT displayed. The track will repeat until you press the RPT button again.

NOTE: The skip and repeat functions use silent periods on the tape to find the end of a song or passage. These features may not work if there is almost no gap between selections, a high noise level, or a silent period in the middle of a selection.

Caring for the Tape and Player

The tape player picks up dirt and oxides from the tape. This contamination builds up over time and causes the sound quality to degrade. To prevent this, you should clean the player after every 30 hours of use.

If you do not clean the tape player regularly, it may eventually become impossible to remove the contamination with a normal cleaning kit. Your dealer has a cleaning kit available.

Use 100-minute or shorter tapes. Tapes longer than that may break or jam the drive.

If the tape is loose, tighten it by turning the hub with a pencil or your finger. If the label is peeling off, remove it or it could cause the tape to jam in the player. Never try to insert a warped or damaged tape in

the player.

Store tapes in their cases to protect them from dust and moisture. Never place tapes where they will be exposed to direct sunlight, high heat, or high humidity. If a tape is exposed to extreme heat or cold, let it reach a moderate temperature before inserting it into the player.

Never try to insert foreign objects into the tape player.

If you see the error message “*T R E R R*” on the display, press the tape eject button to remove the tape from the unit. Make sure the tape is not damaged. If the tape will not eject or the error message stays on after the tape ejects, take your vehicle to your dealer.

Playing the Radio

Canadian EX and EX-L models

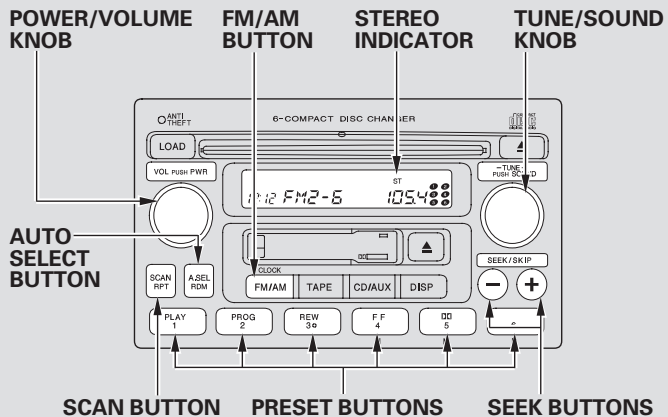

U.S. EX and SE models

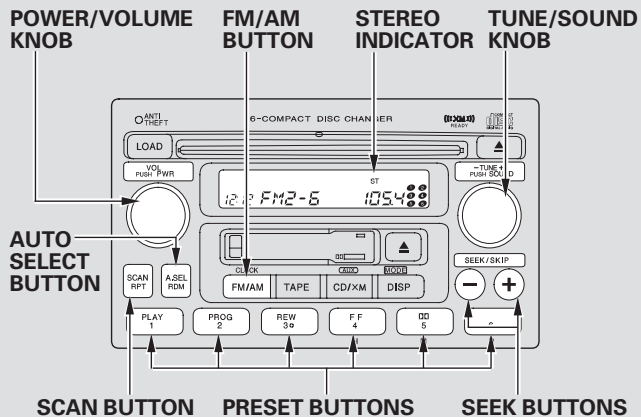

To Play the Radio

The ignition switch must be in the ACCESSORY (I) or the ON (II) position. Turn the system on by pushing the PWR/VOL knob or the FM/AM button. Adjust the volume by turning the PWR/VOL knob.

The band and frequency that the radio was last tuned to is displayed. To change bands, press the FM/AM button. On the FM band, ST will be displayed if the station is broadcasting in stereo. Stereo reproduction on AM is not available.

Optional for U.S. EX and SE models.
XM satellite radio information is available on page 120 .

To Select a Station

You can use any of five methods to find radio stations on the selected band: **TUNE**, **SEEK**, **SCAN**, the preset buttons, and **AUTO SELECT**.

TUNE — Use the TUNE knob to tune the radio to a desired frequency. Turn the knob right to tune to a higher frequency, or left to tune to a lower frequency.

SEEK — The SEEK function searches up and down from the current frequency to find a station with a strong signal. To activate it, press the ⊕ or ⊖ SEEK button, then release it.

SCAN — The SCAN function samples all stations with strong signals on the selected band. To activate it, press the SCAN button, then release it. You will see SCAN in the display. The system will scan for a station with a strong signal. When it finds one, it will stop and play that station for about 5 seconds.

If you do nothing, the system will scan for the next strong station and play it for 5 seconds. When it plays a station you want to listen to, press the SCAN button again.

Playing the Radio

Preset — Each preset button can store one frequency on AM and two frequencies on FM.

1. Select the desired band, AM or FM. FM1 and FM2 let you store two frequencies with each preset button.
2. Use the TUNE, SEEK, or SCAN function to tune the radio to a desired station.
3. Pick a preset button and hold it until you hear a beep.
4. Repeat steps 1 through 3 to store a total of six stations on AM and twelve stations on FM.

The preset frequencies will be lost if your vehicle's battery goes dead, is disconnected, or the radio fuse is removed.

AUTO SELECT — If you are traveling far from home and can no longer receive your preset stations, you can use the auto select feature to find stations in the local area.

Press the A. SEL button. "A.SEL" flashes in the display, and the system goes into scan mode for several seconds. It stores the frequencies of six AM and twelve FM stations in the preset buttons.

You will see a "0" displayed after pressing a preset button if auto select cannot find a strong station for every preset button.

If you do not like the stations auto select has stored, you can store other frequencies on the preset buttons as previously described.

To turn off auto select, press the A. SEL button. This restores the presets you originally set.

Adjusting the Sound

BAL — Adjust the balance or side-to-side strength of the sound.

FAD — Adjust the fader or the front-to-back strength of the sound.

TRE — Adjust the treble in the sound.

BAS — Adjust the bass in the sound.

Press the SOUND knob repeatedly to display the Bass (BAS), Treble (TRE), Fader (FAD), and Balance (BAL) settings.

Each mode is shown in the display as it changes. Turn the SOUND knob to adjust the setting to your liking. When the level reaches the center, you will see a “C” in the display. The system will return to the audio display about 5 seconds after you stop adjusting a mode.

Audio System Lighting

You can use the instrument panel brightness control knob to adjust the illumination of the audio system (see page 67). The audio system illuminates when the parking lights are on, even if the radio is off.

Radio Frequencies and Reception

For information, see page 132 .

Satellite Digital Radio

Optional on U.S. EX and SE models

Your vehicle is capable of receiving XM® satellite radio anywhere in the United States except Hawaii and Alaska.

XM® is a registered trademark of XM Satellite Radio, Inc. Satellite radio is available in U.S. models only.

To Play XM® Satellite Radio

The ignition switch must be in the ACCESSORY (I) or the ON (II) position.

Turn the system on:

Push any of the following: PWR/VOL knob or the CD/XM button.

Turn the PWR/VOL knob to adjust the volume.

To Select a Channel

When in the satellite radio mode,

you can use any of three methods to find channels: TUNE, SEEK/SKIP, and SCAN.

TUNE — Turn the TUNE knob to change channel selection. Turn the knob right for higher numbered channels and left for lower numbered channels.

SEEK/SKIP — The SEEK/SKIP function selects the various categories in XM, such as Jazz/Blues, Rock, Classical, etc. Push the ⊕ to change the category forward. Push the ⊖ to change the category backward. To search for channels within a category, turn the TUNE knob clockwise.

DISP — Press and release this button to change the display. The display will change in the following sequence: channel name, channel number, category, artist name, and music title.

Press and hold this button for more than 2 seconds to change the mode between the channel number and the category.

SCAN — The scan function samples all channels for 5 seconds. To activate the function, push the SCAN button. Push it again to get out of the sequence.

Preset — Each preset button can store one channel in XM1 and one in XM2.

1. Push the CD/XM button, you will see XM1 or XM2.
2. Use the TUNE, SEEK or SCAN function to tune the radio to a desired channel.
3. Pick a preset button and hold it until you hear a beep.
4. Repeat steps 1 to 3 to store a total of six stations on XM1 and six on XM2.

Playing the XM[®] Satellite Radio (optional)

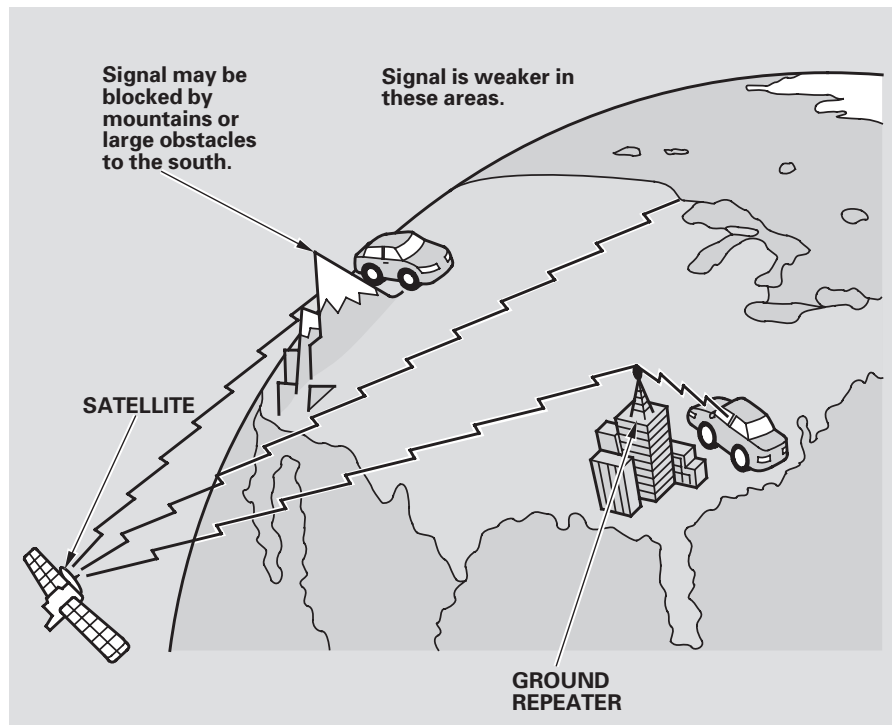

Satellite Radio Signals

Satellite radio receives signals from two satellites to produce clear, high-quality digital reception. It offers many channels in several categories. Along with a large selection of different types of music, satellite radio also allows you to view channel and category selections in the audio display.

The XM satellites are in orbit over the equator; therefore, objects south of the vehicle may cause satellite reception interruptions. To help compensate for this, ground-based repeaters are placed in major metropolitan areas.

Satellite signals are more likely to be blocked by tall buildings and mountains the farther north you travel from the equator.

Depending on where you drive, you may experience reception problems. Interference can be caused by any of these conditions:

- Driving on the south side of an east/west mountain road.
- Driving on the north side of a large commercial truck on an east/west road.
- Driving in tunnels.
- Driving on a road beside a vertical wall, steep cliff, or hill to the south of you.
- Driving on the lower level of a multi-tiered road.
- Driving on a single lane road alongside dense trees taller than 50 ft. (15 m) to the south of you.

There may also be other geographic situations that could affect satellite radio reception.

*As required by the FCC:
Changes or modifications not expressly approved by the party responsible for compliance could void the user's authority to operate the equipment.*

Receiving Satellite Radio Service

If your XM Radio service has expired or you purchased your vehicle from a previous owner, you can listen to a sampling of the broadcasts available on XM satellite radio. With the ignition switch in the ACCESSORY (I) or the ON (II) position, push the PWR/VOL knob to turn on the audio system, and press the CD/XM button. A variety of music types and styles will play.

If you decide to purchase XM satellite radio service, contact XM Radio at www.xmradio.com, or at 1-800-852-9696. You will need to give them your radio I.D. number and your credit card number. To get your radio I.D. number, turn the TUNE

knob until "0" appears in the display. Your I.D. will appear in the display.

After you've registered with XM Radio, keep your audio system in the satellite radio mode while you wait for activation. This should take about 30 minutes.

While waiting for activation, make sure your vehicle remains in an open area with good reception. Once your audio system is activated, "category" or "CH" will appear in the display, and you'll be able to listen to XM Radio broadcasts. XM Radio will continue to send an activation signal to your vehicle for at least 12 hours from the activation request. If the service has not been activated after 36 hours, contact XM Radio.

Playing a Disc

Canadian EX and EX-L models

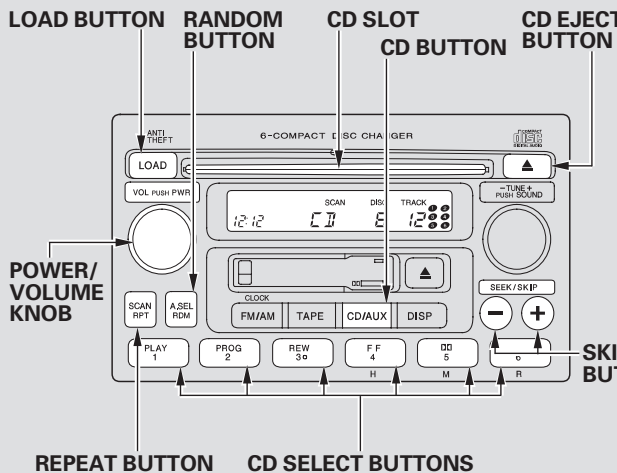

U.S. EX and SE models

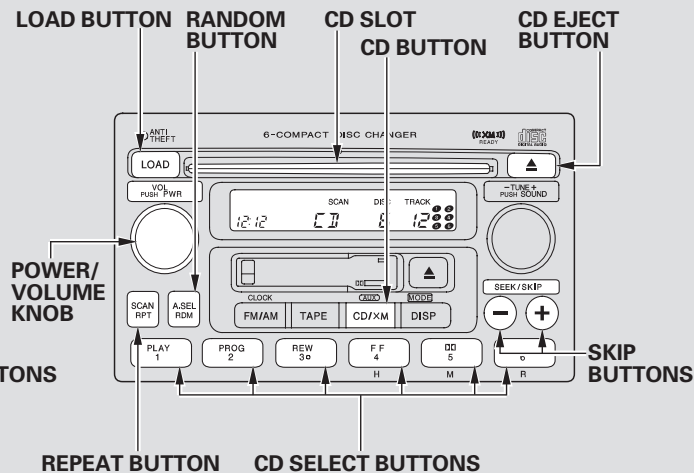

To Play a CD

To load or play CDs, the ignition switch must be in the ACCESSORY (I) or the ON (II) position.

You operate the CD player/CD changer with the same controls used for the radio. To select the CD player/CD changer, press the CD button. The number of the track playing is shown in the display. With the in-dash CD changer, the disc and track numbers are displayed. The system will continuously play a CD until you change modes.

You can also play 3-inch (8-cm) discs without using an adapter ring.

NOTICE

Do not use discs with adhesive labels. The label can curl up and cause the disc to jam in the unit.

To play the radio when a CD is playing, press the AM/FM button. Press the CD button again to switch back to the CD player.

To play the tape when a CD is playing, insert a tape in the player. If a tape is in the player, press the TAPE button. Press the CD button again to switch back to the CD player.

If you turn the system off while a CD is playing, either with the PWR/VOL knob or by turning off the ignition, the disc will stay in the drive. When you turn the system back on, the CD will begin playing where it left off.

Loading CDs in the In-dash CD Changer

Your vehicle's in-dash CD changer holds up to six discs.

1. Press the LOAD button until you hear a beep and see "LOAD" in the display.
To load only one CD, press and release the LOAD button.
2. The disc number for an empty position is highlighted.
3. Insert the disc into the CD slot when the green CD load indicator comes on. Insert it only about halfway; the drive will pull it in the rest of the way. You will see "BUSY" in the display while the CD load indicator turns red and blinks as the CD is loaded.

You cannot load and play 3-inch (8-cm) discs in this system.

CONTINUED

Playing a Disc

4. When the CD load indicator turns green and "LOAD" appears in the screen again, insert the next CD in the slot. Do not try to insert a CD until "LOAD" appears. You could damage the audio unit.
5. Repeat this until all six positions are loaded. If you are not loading all six positions, the system begins playing the last CD loaded.

You can also load a CD into an empty position while a CD is playing by pressing the appropriate preset button. The system stops playing the current CD and starts the loading sequence. It plays the CD just loaded.

For models with XM Radio

To listen to satellite radio when a CD is playing, press the CD/XM button.

DISP — Press and release the DISP button to switch the display between the track and disc numbers and the elapsed time for the current CD.

To Change or Select Tracks

SKIP — Each time you press and release the ⊕ skip button the player skips forward to the beginning of the next track. Press and release the ⊖ skip button to skip backward to the beginning of the current track. Press it again to skip to the beginning of the previous track.

To move rapidly within a track, press and hold the ⊕ or ⊖ skip button.

REPEAT — To continuously replay a track, press and release the RPT button. You will see RPT in the display. Press it again to turn it off.

RANDOM — This feature plays the tracks in random order. To activate random play, press and release the RDM button. You will see RDM in the display. Press it again to return to normal play.

SCAN — The SCAN function samples all the tracks on the selected disc in the order they are recorded on the CD. To activate it, press and hold the SCAN button. You will see SCAN in the display. You will get a 10 second sampling of each track on the selected CD. Press the SCAN button again to get out of the system and play the last track sampled.

To select a different CD, use the appropriate preset buttons (1 to 6).

To Stop Playing a CD

Press the FM/AM or CD button to switch to the radio or satellite radio while a CD is playing. To play the CD, press the CD button again.

If a tape is in the tape player, press the TAPE button to switch to the tape while a CD is playing. Press the CD button again to switch back to the CD player/CD changer.

If you turn the system off while a CD is playing, either with the PWR/VOL knob or by turning off the ignition, the disc will stay in the drive. When you turn the system back on, the CD will begin playing where it left off.

Removing CDs from the In-dash CD Changer

To remove the disc currently in play, press the eject (▲) button. When a disc is removed from a slot, the system automatically begins the load sequence so you can load another CD in that position. If you do not remove the disc from the changer within 10 seconds, the system returns to the previous mode (AM/FM or satellite radio). The disc will reload into the system and will remain there in a pause mode.

To remove a different CD from the changer, first select it with the appropriate preset button. When that CD begins playing, press the eject button. Continue pressing the eject button to remove all the discs from the changer.

You can also eject discs when the ignition switch is off. The disc that was last selected is ejected first.

Protecting Discs

For information on how to handle and protect discs, see page [134](#).

Disc Changer Error Messages

If you see an error message in the display while playing a CD, find the cause in the chart to the right. If you cannot clear the error message, take the vehicle to your dealer.

CD Changer

Error Message	Cause	Solution
<i>CD DISC</i> <i>CD ERROR</i>	FOCUS Error Mechanical Error	Press the CD eject button and pull out the CDs. Check for an error message, and insert the CDs again. If the message does not disappear or the CDs cannot be pulled out, see your dealer.
<i>CD EJECT</i>	No CD in the CD changer	Insert CDs.

Canadian EX and EX-L models

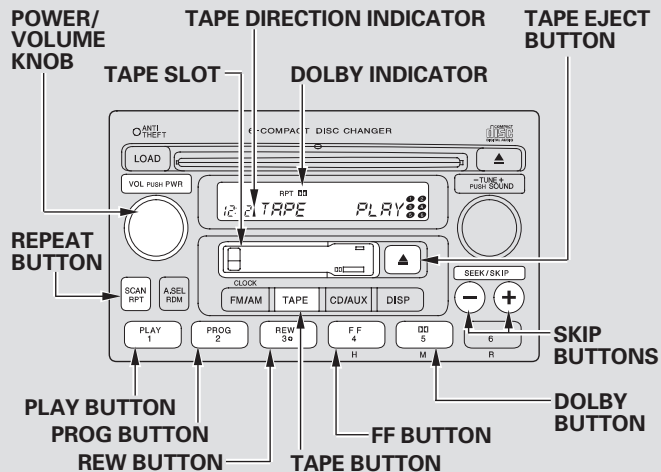

U.S. EX and SE models

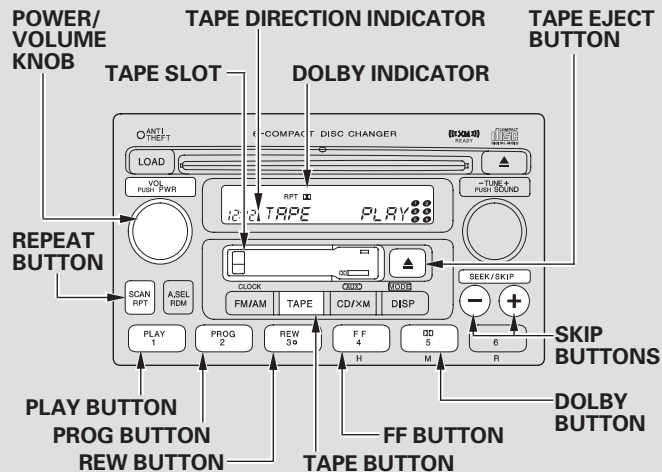

Playing a Tape

To Play a Tape

The ignition switch must be in the ACCESSORY (I) or the ON (II) position. Make sure the open side of the tape is facing right, then insert the tape most of the way into the slot. The system will pull the tape in the rest of the way and begin to play it.

The tape direction indicator in the display comes on to show you which side of the tape is playing. The ▲ indicates the side you inserted upward is now playing. If you want to play the other side, press the PROG button. When the player reaches the end of the tape, it will automatically reverse direction and play the other side.

Dolby* noise reduction turns on when you insert a tape. The □□ indicator will light in the display. If the tape was not recorded in Dolby, turn it off by pressing the □□ button. Dolby remains off until you press the □□ button again.

* Dolby noise reduction is manufactured under license from Dolby Laboratories Licensing Corporation. "DOLBY" and the double-D symbol □□ are trademarks of Dolby Laboratories Licensing Corporation.

To Stop Playing a Tape

To remove the tape, press the eject button. If you want to turn the player off, press the PWR/VOL knob or turn off the ignition. The tape will remain in the drive. When you turn the system back on, the tape will begin playing where it left off.

To switch to the radio, XM Radio (optional on U.S. EX and SE models), or CD changer while a Tape is playing, press the FM/AM or CD/XM button. To change back to the tape player, press the TAPE button.

Tape Search Functions

FF/REW — To rewind the tape, push the REW button. You will see REW in the display. To fast forward the tape, push the FF button. You will see FF displayed. Press the FF, REW, or PLAY button to take the system out of rewind or fast forward.

SKIP — Press the ⊖ button to find the beginning of the current song or passage. Press the ⊕ button to find the beginning of the next song or passage. When the system reaches the beginning of a song or passage, it begins to play it.

REPEAT — Press the RPT button to continuously play a song or passage. You will see RPT displayed. The track will repeat until you press the RPT button again.

NOTE: The skip and repeat functions use silent periods on the tape to find the end of a song or passage. These features may not work if there is almost no gap between selections, a high noise level, or a silent period in the middle of a selection.

Caring for the Tape and Player

The tape player picks up dirt and oxides from the tape. This contamination builds up over time and causes the sound quality to degrade. To prevent this, you should clean the player after every 30 hours of use.

If you do not clean the tape player regularly, it may eventually become impossible to remove the contamination with a normal cleaning kit. Your dealer has a cleaning kit available.

Use 100-minute or shorter tapes. Tapes longer than that may break or jam the drive.

If the tape is loose, tighten it by turning the hub with a pencil or your finger. If the label is peeling off, remove it or it could cause the tape to jam in the player. Never try to insert a warped or damaged tape in

the player.

Store tapes in their cases to protect them from dust and moisture. Never place tapes where they will be exposed to direct sunlight, high heat, or high humidity. If a tape is exposed to extreme heat or cold, let it reach a moderate temperature before inserting it into the player.

Never try to insert foreign objects into the tape player.

If you see the error message “TAPE ERROR” on the display, press the tape eject button to remove the tape from the unit. Make sure the tape is not damaged. If the tape will not eject or the error message stays on after the tape ejects, take your vehicle to your dealer.

Radio Reception

Radio Frequencies

The radio can receive the complete AM and FM bands.

Those bands cover these frequencies:

AM band: 530 to 1,710 kilohertz

FM band: 87.7 to 107.9 megahertz

Radio stations on the AM band are assigned frequencies at least 10 kilohertz apart (530, 540, 550).

Stations on the FM band are assigned frequencies at least 0.2 megahertz apart (87.9, 88.1, 88.3).

Stations must use these exact frequencies. It is fairly common for stations to round off the frequency in their advertising, so your radio could display a frequency of 100.9 even though the announcer may identify the station as "FM101."

Radio Reception

How well the radio receives stations is dependent on many factors, such as the distance from the station's transmitter, nearby large objects, and atmospheric conditions.

A radio station's signal gets weaker as you get farther away from its transmitter. If you are listening to an AM station, you will notice the sound volume becoming weaker, and the station drifting in and out. If you are listening to an FM station, you will see the stereo indicator flickering off and on as the signal weakens. Eventually, the stereo indicator will go off and the sound will fade completely as you get out of range of the station's signal.

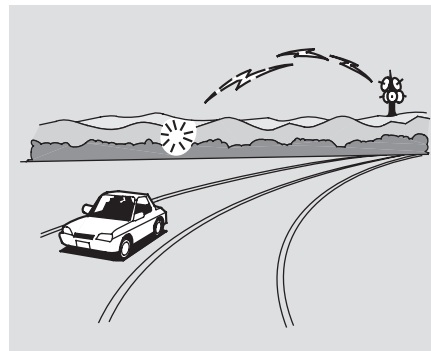

Driving very near the transmitter of a station that is broadcasting on a frequency close to the frequency of the station you are listening to can also affect your radio's reception. You may temporarily hear both stations, or hear only the station you are close to.

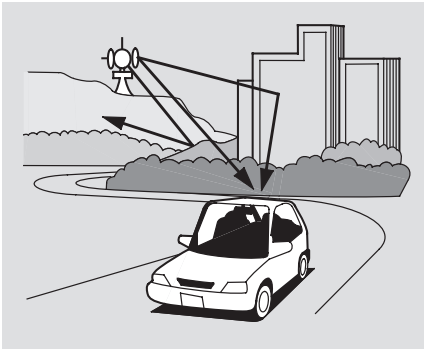

Radio signals, especially on the FM band, are deflected by large objects such as buildings and hills. Your radio then receives both the direct signal from the station's transmitter, and the deflected signal. This causes the sound to distort or flutter. This is a main cause of poor radio reception in city driving.



Radio reception can be affected by atmospheric conditions such as thunderstorms, high humidity, and even sunspots. You may be able to receive a distant radio station one day and not receive it the next day because of a change in conditions.

Electrical interference from passing vehicles and stationary sources can cause temporary reception problems.

*As required by the FCC:
Changes or modifications not expressly
approved by the party responsible for
compliance could void the user's
authority to operate the equipment.*

Protecting Your Discs

Protecting Your CDs

General Information

- When using CD-R/CD-RW discs, use only high quality CDs labeled for audio use.
- When recording a CD-R/CD-RW, the recording must be closed for it to be used by the system.
- Play only standard round CDs. Odd-shaped CDs may jam in the drive or cause other problems.
- Handle your CDs properly to prevent damage and skipping.

Protecting CDs

When a CD is not being played, store it in its case to protect it from dust and other contamination. To prevent warpage, keep CDs out of direct sunlight and extreme heat.

To clean a CD, use a clean soft cloth. Wipe across the CD from the center to the outside edge.

A new CD may be rough on the inner and outer edges. The small plastic pieces causing this roughness can flake off and fall on the recording surface of the CD, causing skipping or other problems. Remove these pieces by rubbing the inner and outer edges with the side of a pencil or pen.

Never try to insert foreign objects in the CD player/CD changer or the magazine.

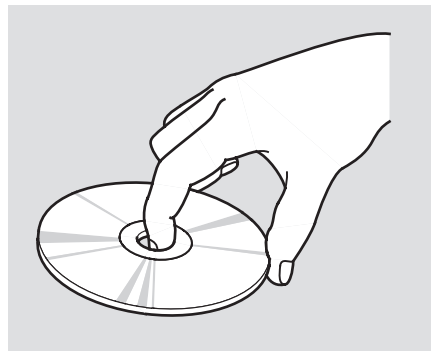

Handle a CD by its edges; never touch either surface. Do not place stabilizer rings or labels on the CD. These, along with contamination from fingerprints, liquids, and felt-tip pens, can cause the CD to not play properly or possibly jam in the drive.

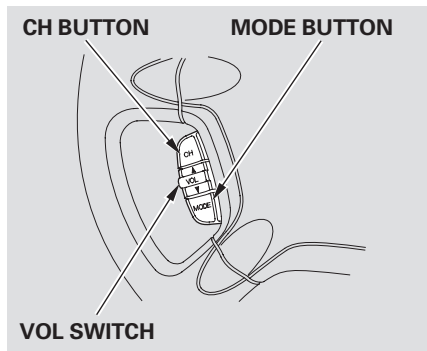

If equipped

Three controls for the audio system are mounted in the steering wheel hub. These let you control basic functions without removing your hand from the wheel.

The VOL switch adjusts the volume up (▲) or down (▼). Push the switch up or down and hold it until the desired volume is reached, then release it.

The MODE button changes the mode. Pressing the button repeatedly selects FM1, FM2, AM, CD (if a CD is loaded), or a tape. On models with satellite radio system, you can also select XM1 and XM2.

If you are listening to the radio, use the CH button to change stations. Each time you press the button, the system goes to the next preset station on the band you are listening to.

If you are playing a CD, the system skips to the beginning of the next track each time you push the CH button. You will see the disc and track number in the display.

If you are playing a tape, press the CH button to advance to the next selection. The system senses a silent period, then resumes playing.

Radio Theft Protection

Your vehicle's audio system will disable itself if it is disconnected from electrical power for any reason. To make it work again, you must enter a specific five-digit code in the preset buttons. Because there are hundreds of number combinations possible from five digits, making the system work without knowing the exact code is nearly impossible.

You should have received a card that lists your audio system's code and serial numbers. It is best to store this card in a safe place at home. In addition, you should write the audio system's serial number in this owner's manual.

If you lose the card, you must obtain the code number from a dealer. To do this, you will need the system's serial number.

If your vehicle's battery is disconnected or goes dead, or the radio fuse is removed, the audio system will disable itself. If this happens, you will see CODE in the frequency display the next time you turn on the system. Use the preset buttons to enter the five-digit code. The code is on the radio code card included in your owner's manual kit. When it is entered correctly, the radio will start playing.

If you make a mistake entering the code, do not start over; complete the five-digit sequence, then enter the correct code. You have 10 tries to enter the correct code. If you are unsuccessful in 10 attempts, you must then leave the system on for 1 hour before trying again.

You will have to store your favorite stations in the preset buttons after the system begins working. Your original settings were lost when the power was disconnected.

If your vehicle's battery is disconnected or goes dead, you will need to set the clock.

Press the **CLOCK** button until you hear a beep. The displayed time begins to blink. Change the hours by pressing the **H** (preset 4) button until the numbers advance to the desired time. Change the minutes by press the **M** (preset 5) button until the numbers advance to the desired time.

When you are finished, press the **CLOCK** button again.

You can quickly set the time to the nearest hour. If the displayed time is before the half hour, press the **CLOCK** button until you hear a beep, then press the **R** (preset 6) button to set the clock back to the previous hour. If the displayed time is after the half hour, the clock sets forward to the

**U.S.: LX model
Canada: SE model**

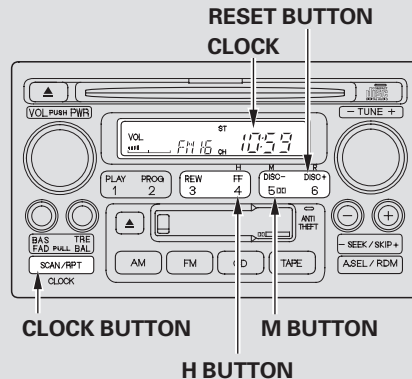

**U.S.: EX and SE models
Canada: EX and EX-L models**

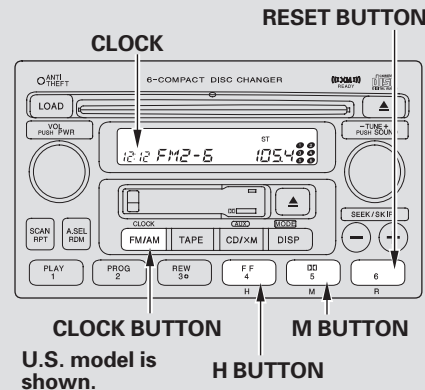

beginning of the next hour.

For example:
1:06 will reset to 1:00
1:53 will reset to 2:00

Cruise Control

Cruise control allows you to maintain a set speed above 25 mph (40 km/h) without keeping your foot on the accelerator pedal. It should be used for cruising on straight, open highways. It is not recommended for city driving, winding roads, slippery roads, heavy rain, or bad weather.

⚠ WARNING

Improper use of the cruise control can lead to a crash.

Use the cruise control only when traveling on open highways in good weather.

Using the Cruise Control

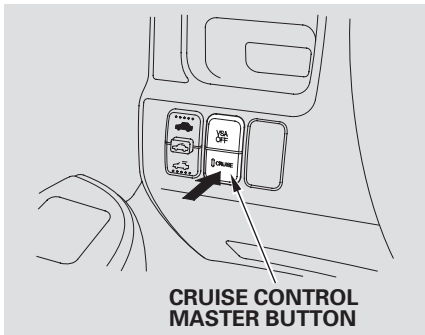

1. Push in the cruise control master button. The indicator will come on.
2. Accelerate to the desired cruising speed above 25 mph (40 km/h).

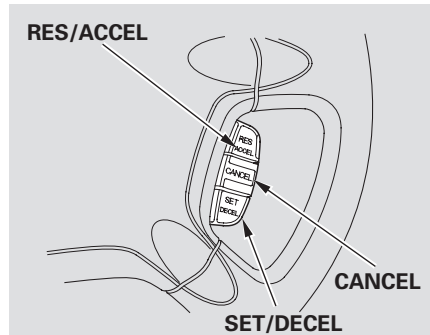

3. Press and release the SET/DECEL button on the steering wheel. The CRUISE CONTROL indicator on the instrument panel comes on to show the system is now activated.

Cruise control may not hold the set speed when you are going up and down hills. If your speed increases going down a hill, use the brakes to slow down. This will cancel the cruise control. To resume the set speed, press the RES/ACCEL button. The CRUISE CONTROL indicator on the instrument panel will come back on.

When climbing a steep hill, the automatic transmission may downshift to hold the set speed.

Changing the Set Speed

You can increase the set cruising speed in any of these ways:

- Press and hold the RES/ACCEL button. When you reach the desired cruising speed, release the button.
- Push on the accelerator pedal until you reach the desired cruising speed, then press the SET/DECEL button.
- To increase the speed in very small amounts, tap the RES/ACCEL button. Each time you do this, your vehicle will speed up about 1 mph (1.6 km/h).

You can decrease the set cruising speed in any of these ways:

NOTE: If you need to decrease your speed quickly, use the brakes as you normally would.

- Press and hold the SET/DECEL button. Release the button when you reach the desired speed.
- To slow down in very small amounts, tap the SET/DECEL button. Each time you do this, your vehicle will slow down about 1 mph (1.6 km/h).
- Tap the brake or clutch pedal lightly with your foot. The CRUISE CONTROL indicator on the instrument panel goes out. When the vehicle slows to the desired speed, press the SET/DECEL button.

CONTINUED

Cruise Control

Even with the cruise control turned on, you can still use the accelerator pedal to speed up for passing. After completing the pass, take your foot off the accelerator pedal. The vehicle will return to the set cruising speed.

Resting your foot on the brake or clutch pedal causes the cruise control to cancel.

Canceling Cruise Control

You can cancel cruise control in any of these ways:

- Tap the brake or clutch pedal.
- Push the CANCEL button on the steering wheel.
- Push the cruise control master button.

Resuming the Set Speed

When you push the CANCEL button, or tap the brake or clutch pedal, the system remembers the previously set cruising speed. To return to that speed, accelerate to above 25 mph (40 km/h) and then press and release the RES/ACCEL button. The CRUISE CONTROL indicator comes on, and the vehicle will accelerate to the same cruising speed as before.

Pressing the cruise control master button turns the system off and erases the previous cruising speed.

Before you begin driving your vehicle, you should know what gasoline to use and how to check the levels of important fluids. You also need to know how to properly store luggage or packages. The information in this section will help you. If you plan to add any accessories to your vehicle, please read the information in this section first.

Break-in Period	142
Fuel Recommendation	142
Service Station Procedures	143
Refueling.....	143
Opening and Closing the Hood	144
Oil Check	145
Engine Coolant Check	146
Fuel Economy	147
Accessories and Modifications	148
Carrying Cargo	150

Break-in Period, Fuel Recommendation

Break-in Period

Help assure your vehicle's future reliability and performance by paying extra attention to how you drive during the first 600 miles (1,000 km). During this period:

- Avoid full-throttle starts and rapid acceleration.
- Do not change the oil until the scheduled maintenance time.
- Avoid hard braking for the first 200 miles (300 km).
- Do not tow a trailer.

You should also follow these recommendations with an overhauled or exchanged engine, or when the brakes are replaced.

Fuel Recommendation

Your vehicle is designed to operate on unleaded gasoline with a pump octane number of 87 or higher. Use of a lower octane gasoline can cause a persistent, heavy metallic rapping noise that can lead to engine damage.

We recommend using gasoline containing detergent additives that help prevent fuel system and engine deposits.

In addition, in order to maintain good performance, fuel economy, and emissions control, we strongly recommend, in areas where it is available, the use of gasoline that does NOT contain manganese-based fuel additives such as MMT.

Use of gasoline with these additives may adversely affect performance, and cause the malfunction indicator lamp on your instrument panel to come on. If this happens, contact

your authorized dealer for service.

Some gasoline today is blended with oxygenates such as ethanol or MTBE. Your vehicle is designed to operate on oxygenated gasoline containing up to 10 percent ethanol by volume and up to 15 percent MTBE by volume. Do not use gasoline containing methanol.

If you notice any undesirable operating symptoms, try another service station or switch to another brand of gasoline.

For further important fuel-related information, please refer to your **Quick Start Guide**.

Refueling

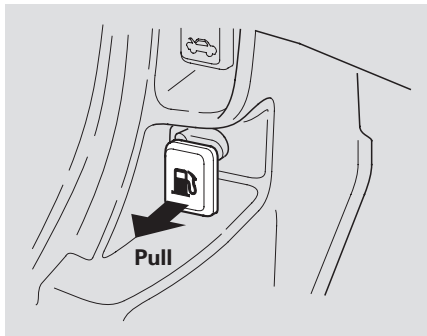

1. Park with the driver's side closest to the service station pump.
2. Open the fuel fill door by pulling on the handle located under the lower left corner of the dashboard.

⚠ WARNING

Gasoline is highly flammable and explosive. You can be burned or seriously injured when handling fuel.

- Stop the engine, and keep heat, sparks, and flame away.
- Handle fuel only outdoors.
- Wipe up spills immediately.

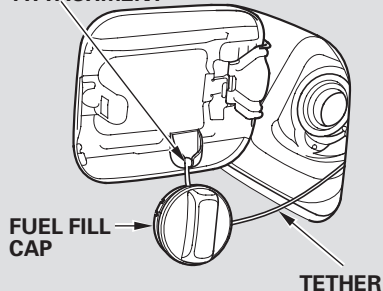
ATTACHMENT

3. Remove the fuel fill cap slowly. You may hear a hissing sound as pressure inside the tank escapes. The fuel fill cap is attached to the fuel filler with a tether. Put the attachment on the fuel fill cap into the slit on the fuel fill door.
4. Stop filling the tank after the fuel nozzle automatically clicks off. Do not try to "top off" the tank. Leave some room for the fuel to expand with temperature changes.

If the fuel nozzle keeps clicking off even though the tank is not full, there may be a problem with your vehicle's fuel vapor recovery system. The system helps keep fuel vapors from going into the atmosphere. Try filling at another pump. If this does not fix the problem, consult your dealer.

CONTINUED

5. Screw the fuel fill cap back on until it clicks at least once. If you do not properly tighten the cap, the malfunction indicator lamp may come on (see page 234).
6. Push the fuel fill door closed until it latches.

Opening and Closing the Hood

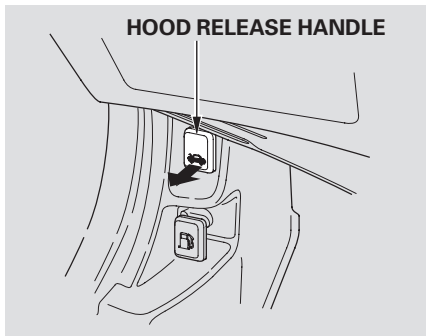

1. Park the vehicle, and set the parking brake. Pull the hood release handle located under the lower left corner of the dashboard. The hood will pop up slightly.

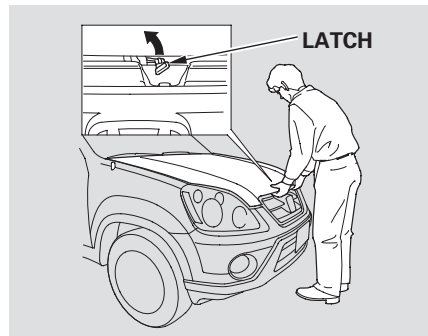

2. Reach in between the hood and the front grille with your fingers. The hood latch handle is above the "H" logo. Push this handle up until it releases the hood. Lift the hood.

If the hood latch handle moves stiffly, or if you can open the hood without lifting the handle, the mechanism should be cleaned and lubricated.

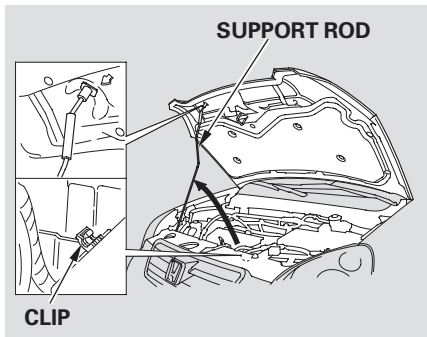

3. Pull the support rod out of its clip, and insert the end into the designated hole in the hood.

To close the hood, lift it up slightly to remove the support rod from the hole. Put the support rod back into its holding clip. Lower the hood to about a foot (30 cm) above the fender, then let it drop. Make sure it is securely latched.

Oil Check

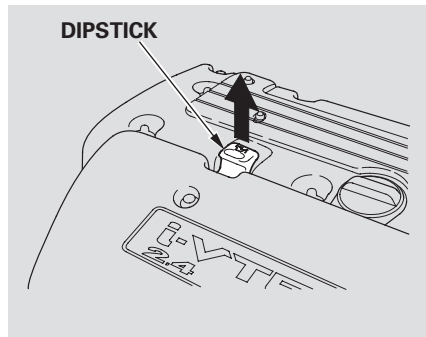

Wait a few minutes after turning the engine off before you check the oil.

1. Remove the dipstick (orange handle).
2. Wipe off the dipstick with a clean cloth or paper towel.
3. Insert it all the way back in its hole.

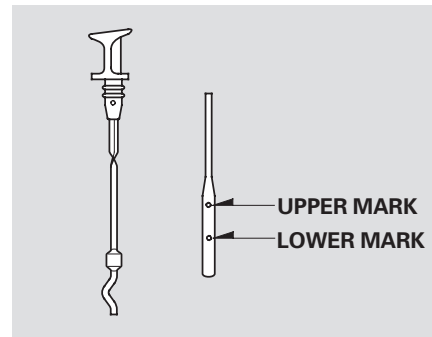

4. Remove the dipstick again, and check the level. It should be between the upper and lower marks.

If it is near or below the lower mark, see **Adding Engine Oil** on page [193](#).

Engine Coolant Check

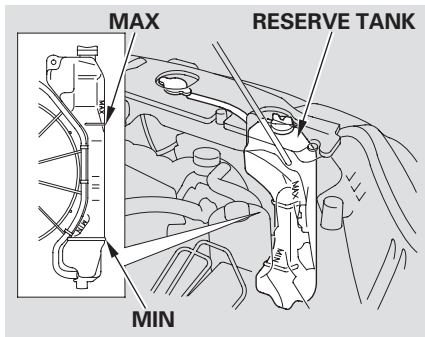

Look at the coolant level in the radiator reserve tank. Make sure it is between the MAX and MIN lines. If it is below the MIN line, see **Adding Engine Coolant** on page [196](#) for information on adding the proper coolant.

Refer to **Owner's Maintenance Checks** on page [186](#) for information about checking other items on your vehicle.

Improving Fuel Economy

- Always maintain your vehicle according to the maintenance schedule. See **Owner's Maintenance Checks** (see page 186).

For example, an underinflated tire causes more “rolling resistance,” which uses more fuel.

The build-up of snow or mud on your vehicle's underside adds weight and rolling resistance. Frequent cleaning helps your fuel mileage and reduces the chance of corrosion.

- Drive moderately. Rapid acceleration, abrupt cornering, and hard braking use more fuel.
- Always drive in the highest gear possible.

- Try to maintain a constant speed. Every time you slow down and speed up, your vehicle uses extra fuel. Use cruise control when appropriate.
- Combine several short trips into one.
- The air conditioning puts an extra load on the engine which makes it use more fuel. Use the fresh-air ventilation when possible.

Accessories and Modifications

Modifying your vehicle, or installing some non-Honda accessories, can make it unsafe. Before you make any modifications or add any accessories, be sure to read the following information.

Accessories

Your dealer has Honda accessories that allow you to personalize your vehicle. These accessories have been designed and approved for your vehicle, and are covered by warranty.

Although non-Honda accessories may fit on your vehicle, they may not meet factory specifications, and could adversely affect your vehicle's handling and stability.

WARNING

Improper accessories or modifications can affect your vehicle's handling, stability, and performance, and cause a crash in which you can be hurt or killed.

Follow all instructions in this owner's manual regarding accessories and modifications.

When properly installed, cellular phones, alarms, two-way radios, and low-powered audio systems should not interfere with your vehicle's computer controlled systems, such as your airbags and anti-lock brakes.

Before installing any accessory:

- Make sure the accessory does not obscure any lights, or interfere with proper vehicle operation or performance.
- Be sure electronic accessories do not overload electrical circuits (see page [237](#)) or interfere with proper operation of your vehicle.
- Before installing any electronic accessory, have the installer contact your dealer for assistance. If possible, have your dealer inspect the final installation.
- Do not install accessories on the side pillars or across the rear windows. In these areas, accessories may interfere with proper operation of the side curtain airbags.

Modifying Your Vehicle

Removing parts from your vehicle, or replacing components, with non-Honda components could seriously affect your vehicle's handling, stability, and reliability.

Some examples are

- Lowering your vehicle with a non-Honda suspension kit that significantly reduces ground clearance can allow the undercarriage to hit speed bumps or other raised objects, which could cause the airbags to deploy.
- Raising your vehicle with a non-Honda suspension kit can affect the handling and stability.
- Non-Honda wheels, because they are a universal design, can cause excessive stress on suspension components.

- Larger or smaller wheels and tires can interfere with the operation of your vehicle's anti-lock brakes and other systems.
- Modifying your steering wheel or any other part of your vehicle's safety features can make the systems ineffective.

If you plan to modify your vehicle, consult your dealer.

Carrying Cargo

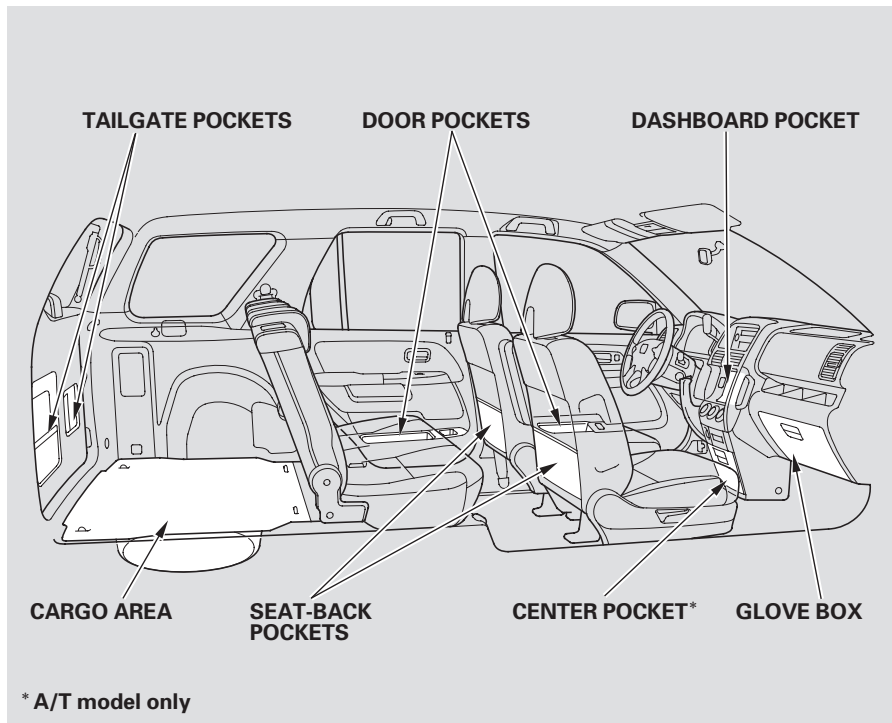

Your vehicle has several convenient storage areas:

- Tailgate pockets
- Glove box
- Dashboard pocket
- Door pockets
- Seat-back pockets
- Center pocket
- Cargo area, including the rear seats when folded up or down.

However, carrying too much cargo, or improperly storing it, can affect your vehicle's handling, stability, stopping distance, and tires, and make it unsafe. Before carrying any type of cargo, be sure to read the following pages.

Load Limits

The maximum load for your vehicle is 850 lbs (385 kg) for U.S.A, 395 kg for Canada. This figure includes the total weight of all occupants, cargo, and accessories, and the tongue load if you are towing a trailer.

⚠ WARNING

Overloading or improper loading can affect handling and stability and cause a crash in which you can be hurt or killed.

Follow all load limits and other loading guidelines in this manual.

Steps for determining correct load limit:

1. Locate the statement, “the combined weight of occupants and cargo should never exceed 850 lbs” on your vehicle’s placard. [The placard is on the driver’s doorjamb.]
2. Determine the combined weight of the driver and passengers that will be riding in your vehicle.
3. Subtract the combined weight of the driver and passengers from 850 lbs.
4. The resulting figure equals the available amount of cargo and luggage load capacity. For example, if the maximum load is 850 lbs and there will be five 150 lb. passengers in your vehicle, the amount of available cargo and luggage load capacity is 100 lbs. [850 – 750 (5 × 150) = 100 lbs.]

5. Determine the combined weight of luggage and cargo being loaded in the vehicle. That weight may not safely exceed the available cargo and luggage load capacity in step 4.
6. If your vehicle will be towing a trailer, load from your trailer will be transferred to your vehicle. Consult this manual to determine how this reduces the available cargo and luggage load capacity of your vehicle. [See page 172.]

In addition, the total weight of the vehicle, all occupants, accessories, cargo, and trailer tongue load must not exceed the gross vehicle weight rating (GVWR) or the gross axle weight rating (GAWR). Both are on a label on the driver’s doorjamb.

CONTINUED

Carrying Cargo

Carrying Cargo in the Passenger Compartment

- Store or secure all items that could be thrown around and hurt someone during a crash.
- Be sure items placed on the floor behind the front seats cannot roll under the seats and interfere with the driver's ability to operate the pedals, the proper operation of the seats, or the advanced front airbags.
- Keep the glove box closed while driving. If it is open, a passenger could injure their knees during a crash or sudden stop.

- If you fold the rear seats up or down, tie down items that could be thrown about the vehicle during a crash or sudden stop. Also, keep all cargo below the bottom of the windows. If it is higher, it could interfere with the proper operation of the side curtain airbags.

Carrying Cargo in the Cargo Area

- Distribute cargo evenly on the floor of the cargo area, placing the heaviest items on the bottom and as far forward as possible. Tie down items that could be thrown about the vehicle during a crash or sudden stop.
- If you carry large items that prevent you from closing the tailgate or the hatch glass, exhaust gas can enter the passenger area. To avoid the possibility of **carbon monoxide poisoning**, follow the instructions on page [50](#).
- If you carry any items on a roof rack, be sure the total weight of the rack and the items does not exceed the maximum allowable weight. Please contact your dealer for further information.

If you use an accessory roof rack, the roof rack weight limit may be lower. Refer to the information that came with your roof rack.

Optional Separation Net

The separation net can be used to hold back soft, lightweight items stored in the cargo area. Heavy items should be properly secured on the floor of the cargo area. The net may not prevent heavy items from being thrown forward in a crash or a sudden stop.

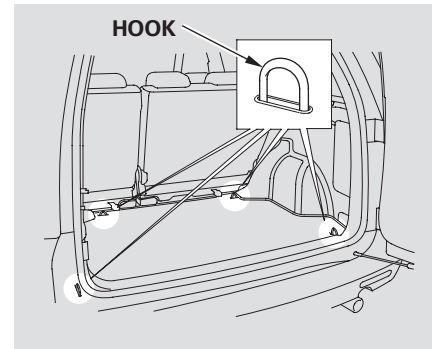

The four hooks on the floor can be used to install a net for securing items.

This section gives you tips on starting the engine under various conditions, and how to operate the manual and automatic transmissions. It also includes important information on parking your vehicle, the braking system, the vehicle stability assist (VSA) system, and facts you need if you are planning to tow a trailer or drive off-highway.

Driving Guidelines..... 156
 Preparing to Drive 157
Starting the Engine..... 158
Manual Transmission..... 159
Automatic Transmission..... 161
Parking..... 166
Braking System..... 167
Anti-lock Brakes (ABS) 168
Vehicle Stability Assist
 (VSA) System..... 170
Towing a Trailer 172
Towing Your Vehicle Behind a
 Motorhome..... 177
Off-Highway Driving
 Guidelines..... 179

Driving Guidelines

Your vehicle has higher ground clearance that allows you to travel over bumps, obstacles, and rough terrain. It also provides good visibility so you can anticipate problems earlier.

Because your vehicle rides higher off the ground, it has a high center of gravity that can cause it to roll over if you make abrupt turns. Utility vehicles have a significantly higher roll over rate than other types of vehicles.

To prevent rollovers or loss of control:

- Take corners at slower speeds than you would with a passenger vehicle.
- Avoid sharp turns and abrupt maneuvers whenever possible.

- Do not modify your vehicle in any way that would raise the center of gravity.
- Do not carry heavy cargo on the roof.

Four-wheel Drive Models

Your vehicle is equipped with a four-wheel drive (4WD) system. When the system senses a loss of front-wheel traction, it automatically transfers some power to the rear wheels. This gives you better traction and mobility.

You still need to exercise the same care when accelerating, steering, and braking that you would in a two-wheel drive vehicle.

See page 179 for off-highway driving guidelines.

Preparing to Drive

You should do these checks and adjustments before you drive your vehicle:

1. Make sure all windows, mirrors, and outside lights are clean and unobstructed. Remove frost, snow, or ice.
2. Check that the hood is fully closed.
3. Visually check the tires. If a tire looks low, use a gauge to check its pressure (see page 213).
4. Check that any items you may be carrying are stored properly or fastened down securely.
5. Check the seat adjustment (see page 78).
6. Check the adjustment of the inside and outside mirrors (see page 88).
7. Check the steering wheel adjustment (see page 69).
8. Make sure the doors, the tailgate, and the hatch glass are securely closed and locked.
9. Fasten your seat belt. Check that your passengers have fastened their seat belts (see page 14).
10. When you start the engine, check the gauges and indicators in the instrument panel (see page 55).

Starting the Engine

1. Apply the parking brake.
2. In cold weather, turn off all electrical accessories to reduce the drain on the battery.
3. *Manual Transmission:*
Push the clutch pedal down all the way. START (III) does not function unless the clutch pedal is depressed.

Automatic Transmission:

Make sure the shift lever is in Park. Press on the brake pedal.

4. Without touching the accelerator pedal, turn the ignition key to the START (III) position. Do not hold the key in the START (III) position for more than 15 seconds at a time. If the engine does not start right away, pause for at least 10 seconds before trying again.

NOTICE

The immobilizer system protects your vehicle from theft. If an improperly-coded key (or other device) is used, the engine's fuel system is disabled. For more information, see page 71 .

5. If the engine does not start within 15 seconds, or starts but stalls right away, repeat step 4 with the accelerator pedal pressed halfway down. If the engine starts, release pressure on the accelerator pedal so the engine does not race.

6. If the engine fails to start, press the accelerator pedal all the way down, and hold it there while starting to clear flooding. If the engine still does not start, return to step 5.

NOTICE

The engine is harder to start in cold weather. Also, the thinner air found at altitudes above 8,000 feet (2,400 meters) adds to this problem.

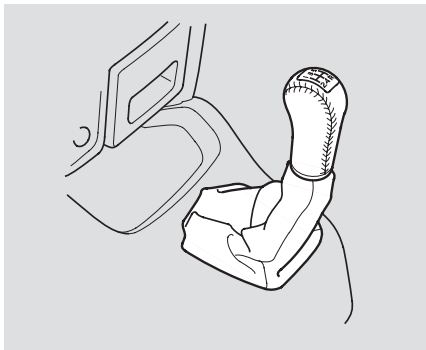

The manual transmission is synchronized in all forward gears for smooth operation. It has a lockout so you cannot shift directly from fifth to reverse. When shifting up or down, make sure you push the clutch pedal down all the way, shift to the next gear, and let the pedal up gradually. Do not skip gears. When you are not shifting, do not rest your foot on the clutch pedal. This can cause your clutch to wear out faster.

Come to a full stop before you shift into reverse. You can damage the transmission by trying to shift into reverse with the vehicle moving. Push down the clutch pedal, and pause for a few seconds before shifting into reverse, or shift into one of the forward gears for a moment. This stops the gears so they won't "grind."

When slowing down, you can get extra braking from the engine by shifting to a lower gear. This extra braking can help you maintain a safe speed and prevent your brakes from overheating while going down a steep hill. To prevent serious engine and transmission damage, do not skip gears when downshifting, and do not let the engine speed go into the red zone of the tachometer.

⚠️ WARNING

Rapid slowing or speeding-up can cause loss of control on slippery surfaces. If you crash, you can be injured.

Use extra care when driving on slippery surfaces.

Recommended Shift Points

Drive in the highest gear that lets the engine run and accelerate smoothly. This will give you good fuel economy and effective emissions control. The following shift points are recommended:

Shift up	Normal acceleration
1st to 2nd	15 mph (24 km/h)
2nd to 3rd	25 mph (40 km/h)
3rd to 4th	40 mph (64 km/h)
4th to 5th	48 mph (77 km/h)

Engine Speed Limiter

If you exceed the maximum speed for the gear you are in, the engine speed will enter into the tachometer's red zone. If this occurs, you may feel the engine cut in and out. This is caused by a limiter in the engine's computer controls. The engine will run normally when you reduce the rpm below the red zone.

The engine speed limiter only works when you upshift; engine speed is not limited during downshifts. To prevent serious engine damage during downshifts, do not skip gears, and do not let the engine speed enter the red zone of the tachometer.

Shift Lever Position Indicators

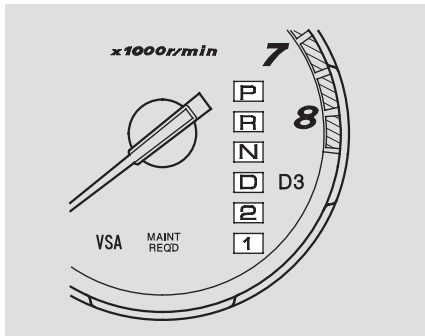

These indicators on the instrument panel show which position the shift lever is in.

The “D” indicator comes on for a few seconds when you turn the ignition switch to the ON (II) position. If it flashes while driving (in any shift position), it indicates a possible problem in the transmission.

If the malfunction indicator lamp comes on along with the “D” indicator, there is a problem in the automatic transmission control system. Avoid rapid acceleration, and have the transmission checked by your dealer as soon as possible.

Shifting

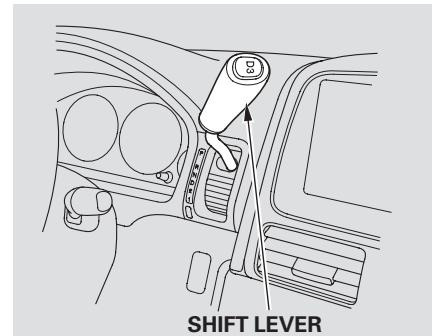

To shift from any position, press firmly on the brake pedal and pull the lever toward you. You cannot shift out of Park when the ignition switch is in the LOCK (0) or the ACCESSORY (I) position.

CONTINUED

Automatic Transmission

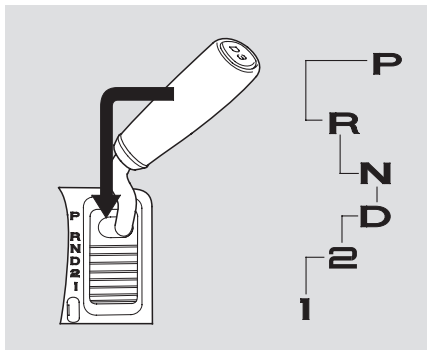

Park (P) — This position mechanically locks the transmission. Use Park whenever you are turning off or starting the engine. To shift out of Park, you must press on the brake pedal and have your foot off the accelerator pedal. Pull the shift lever towards you, then move it out of Park.

If you have done all of the above and still cannot move the lever out of Park, see **Shift Lock Release** on page [165](#) .

You must also pull the shift lever towards you to shift into Park. To avoid transmission damage, come to a complete stop before shifting into Park. The shift lever must be in Park for you to remove the key from the ignition switch.

Reverse (R) — Press the brake pedal and pull the shift lever towards you to shift from Park to reverse. To shift from reverse to neutral, come to a complete stop, and then shift. Pull the shift lever towards you before shifting into reverse from neutral.

Your vehicle has a reverse lockout so you cannot accidentally shift to reverse when the vehicle speed exceeds 5 mph (8 km/h).

If you cannot shift to reverse when the vehicle is stopped, press the brake pedal, slowly shift to neutral, and then shift to reverse.

If there is a problem in the reverse lockout system, or your vehicle's battery is disconnected or goes dead, you cannot shift to reverse. (Refer to **Shift Lock Release** on page [165](#)).

To shift from:	Do this:
P to R	Press the brake pedal and pull the shift lever towards you.
R to P N to R D to 2 2 to 1	Pull the shift lever towards you.
1 to 2 2 to D D to N N to D R to N	Move the shift lever.

Neutral (N) — Use Neutral if you need to restart a stalled engine, or if it is necessary to stop briefly with the engine idling. Shift to the Park position if you need to leave your vehicle for any reason. Press on the brake pedal when you are moving the shift lever from Neutral to another gear.

After you stop in D, 2, 1, N, or R position with the ignition switch in the ACCESSORY (I) position for an extended period, you may not be able to move the shift lever from neutral to reverse or Park. In this case, press the brake pedal, and turn the ignition switch to the ON (II) position, then shift out of neutral.

Drive (D) — Use this position for your normal driving. The transmission automatically selects a suitable gear (1 through 5) for your speed and acceleration. You may notice the transmission shifting up at

higher engine speeds when the engine is cold. This helps the engine warm up faster.

D3 Mode



Press the D3 switch on the edge of the shift lever to turn this mode on or off; the D3 mode indicator comes on whenever the D3 mode is selected.

D3 mode can be turned on or off only when the ignition switch is in

the ON (II) position and the shift lever is in the D position.

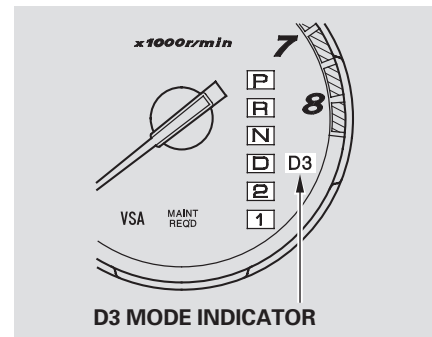

When the D3 mode is on, the transmission selects only the first three gears. Use D3 mode when towing a trailer, or to provide engine braking when going down a steep hill. D3 mode can also keep the transmission from cycling between third and fourth gears in stop-and-go driving.

CONTINUED

Automatic Transmission

Shifting out from the D position will cancel the D3 mode, and the D3 indicator will go out. Selecting the D3 position again will resume the D3 mode and the indicator comes on.

Turning the ignition switch to the LOCK (0) position turns this mode off. When you restart the engine, select the D position and press the D3 mode switch again to use this mode.

The D3 mode indicator also comes on for a few seconds when you turn the ignition switch to the ON (II) position.

Second (2) – To shift to second, pull the shift lever towards you, then shift to the lower gear. This position locks the transmission in second gear. It does not downshift to first gear when you come to a stop.

Use second gear:

- For more power when climbing.
- To increase engine braking when going down steep hills.
- For starting out on a slippery surface or in deep snow.
- To help reduce wheel spin.
- When driving downhill with a trailer.

First (1) – To shift from second to first, pull the shift lever towards you, then shift to the lower gear. This position locks the transmission in first gear. By upshifting and downshifting through 1, 2, and D, you can operate the transmission much like a manual transmission without a clutch pedal.

If you shift into first position when the vehicle speed is above 31 mph (50 km/h), the transmission shifts into second gear first to avoid sudden engine braking.

Engine Speed Limiter

If you exceed the maximum speed for the gear you are in, the engine speed will enter into the tachometer's red zone. If this occurs, you may feel the engine cut in and out. This is caused by a limiter in the engine's computer controls. The engine will run normally when you reduce the rpm below the red zone.

Shift Lock Release

This allows you to move the shift lever out of Park if the normal method of pushing on the brake pedal does not work. This procedure is also used to release the reverse lockout.

1. Set the parking brake.
2. Remove the key from the ignition switch.
3. Put a cloth on the edge of the shift lock release slot cover. Using a small flat-tipped screwdriver or metal fingernail file, carefully pry on the edge of the cover to remove it.

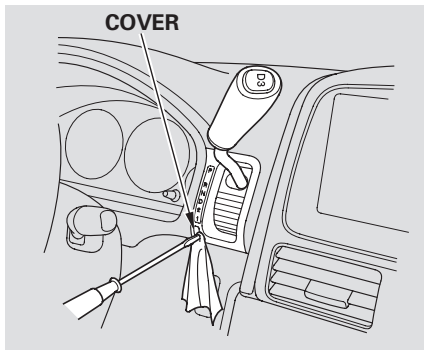

4. Insert a flat-tipped screwdriver into the shift lock release slot.
5. Push down on the screwdriver and move the shift lever out of Park to neutral.

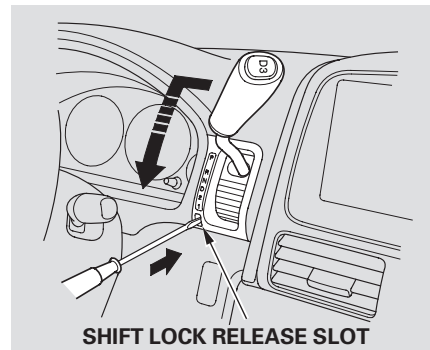

6. Remove the screwdriver from the shift lock release slot, then reinstall the cover. Make sure the notch on the cover is on the right side. Press the brake pedal and restart the engine.

If you need to use the shift lock release, it means your vehicle is developing a problem. Have the vehicle checked by your dealer.

Parking

Always use the parking brake when you park your vehicle. Make sure the parking brake is set firmly, or your vehicle may roll if it is parked on an incline.

If your vehicle has an automatic transmission, set the parking brake before you put the transmission in Park. This keeps the vehicle from moving and putting pressure on the parking mechanism in the transmission.

Parking Tips

- Make sure the moonroof (if equipped) and the windows are closed.
 - Turn off the lights.
 - Place any packages, valuables, etc. in the cargo area or take them with you.
 - Lock the doors and the tailgate. Make sure the hatch glass is closed securely.
 - Never park over dry leaves, tall grass, or other flammable materials. The hot three way catalytic converter could cause these materials to catch on fire.
- If the vehicle is facing uphill, turn the front wheels away from the curb. If you have a manual transmission, put it in first gear.
 - If the vehicle is facing downhill, turn the front wheels toward the curb. If you have a manual transmission, put it in reverse gear.
 - Make sure the parking brake is fully released before driving away. Driving with the parking brake partially set can overheat or damage the rear brakes.

Your vehicle is equipped with disc brakes at all four wheels. A power assist helps reduce the effort needed on the brake pedal. The anti-lock brake system (ABS) helps you retain steering control when braking very hard.

Resting your foot on the pedal keeps the brakes applied lightly, builds up heat, and reduces their effectiveness. It also keeps your brake lights on all the time, confusing drivers behind you.

Constant application of the brakes when going down a long hill builds up heat and reduces their effectiveness. Use the engine to assist the brakes by taking your foot off the accelerator and downshifting to a lower gear.

Check your brakes after driving through deep water. Apply the brakes moderately to see if they feel normal. If not, apply them gently and frequently until they do. Be extra cautious and alert in your driving.

Braking System Design

The hydraulic system that operates the brakes has two separate circuits. Each circuit works diagonally across the vehicle (the left-front brake is connected with the right-rear brake, etc.). If one circuit should develop a problem, you will still have braking at two wheels.

Brake Pad Wear Indicators

The front and rear disc brakes on all models have audible brake wear indicators.

If the brake pads need replacing, you will hear a distinctive, metallic screeching sound when you apply the brake pedal. If you do not have the brake pads replaced, they will screech all the time. It is normal for the brakes to occasionally squeal or squeak when you apply them.

Anti-lock Brakes (ABS)

The anti-lock brake system (ABS) helps prevent the brakes from locking up, and helps you retain steering control by pumping the brakes rapidly, much faster than a person can do it.

The ABS also balances the front-to-rear braking distribution according to vehicle loading.

You should never pump the brake pedal. Let the ABS work for you by always keeping firm, steady pressure on the brake pedal. This is sometimes referred to as “stomp and steer.”

You will feel a pulsation in the brake pedal when the ABS activates, and you may hear some noise. This is normal: it is the ABS rapidly pumping the brakes. On dry pavement, you will need to press on the brake pedal very hard before the ABS activates. However, you may feel the ABS activate immediately if you are trying to stop on snow or ice.



ABS Indicator

If this indicator comes on, the anti-lock function of the braking system has shut down. The brakes still work like a conventional system, but without anti-lock. You should have your dealer inspect your vehicle as soon as possible.

If the ABS indicator comes on while driving, test the brakes as shown on page [235](#).

If the ABS indicator and the brake system indicator come on together, and the parking brake is fully released, the front-to-rear braking distribution system may also be shut down.

Test your brakes as instructed on page 235 . If the brakes feel normal, drive slowly and have your vehicle repaired by your dealer as soon as possible. Avoid sudden hard braking which could cause the rear wheels to lock up and possibly lead to a loss of control.

The VSA indicator will come on along with the ABS indicator.

Important Safety Reminders
ABS does not reduce the time or distance it takes to stop the vehicle. It only helps with the steering control during braking.

ABS will not prevent a skid that results from changing direction abruptly, such as trying to take a corner too fast or making a sudden lane change. Always drive at a safe speed for the road and weather conditions.

ABS cannot prevent a loss of stability. Always steer moderately when you are braking hard. Severe or sharp steering wheel movement can still cause your vehicle to veer into oncoming traffic or off the road.

A vehicle with ABS may require a longer distance to stop on loose or uneven surfaces, such as gravel or snow, than a vehicle without anti-lock. Slow down, and allow a greater distance between vehicles under those conditions.

Vehicle Stability Assist (VSA) System

The vehicle stability assist (VSA) system helps to stabilize the vehicle during cornering if the vehicle turns more or less than desired. It also assists you in maintaining traction while accelerating on loose or slippery road surfaces. It does this by regulating the engine's output and by selectively applying the brakes.

When VSA activates, you may notice that the engine does not respond to the accelerator in the same way it does at other times. You will also see the VSA activation indicator blink.

The VSA system cannot enhance the vehicle's driving stability in all situations and does not control your vehicle's entire braking system. It is still your responsibility to drive and corner at reasonable speeds and to leave a sufficient margin of safety.



VSA Activation Indicator

When VSA activates, you will see the VSA activation indicator blink (see page 58).



Vehicle Stability Assist (VSA) System Indicator

The VSA system indicator (see page 58) comes on and stays on when there is a problem with the VSA system. The VSA activation indicator will also come on.

If this indicator comes on while driving, pull to the side of the road when it is safe, and turn off the engine. Reset the system by restarting the engine. If the VSA system indicator stays on, or comes back on while driving, have the VSA system inspected by your dealer.

If the indicator does not come on when the ignition switch is turned to the ON (II) position, there may be a problem with the VSA system. Have your dealer inspect your vehicle as soon as possible.

Without VSA, your vehicle will have normal braking and cornering ability, but it will not have VSA traction and stability enhancement.

VSA Off Switch

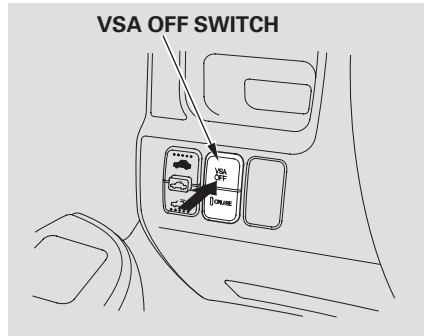

This button is under the driver's side vent. Press it to turn the VSA system on or off.

When VSA is off, the VSA activation indicator comes on as a reminder. Pressing the switch again turns the system back on.

VSA is turned on every time you start the engine, even if you turned it off the last time you drove the vehicle.

VSA and Tire Sizes

Driving with varying tire or wheel sizes may cause the VSA to malfunction. When replacing tires, make sure they are the same size and type as your original tires (see [page 215](#)).

If you install winter tires, make sure they are the same size as those that were originally supplied with your vehicle. Exercise the same caution during winter driving as you would if your vehicle was not equipped with VSA.

Towing a Trailer

Your vehicle has been designed to primarily carry passengers and their cargo. You can also use it to tow a trailer if you carefully observe the load limits, use the proper equipment, and follow the guidelines in this section.

Be sure to read the **Off-Highway Driving Guidelines** section on page 179 if you plan to tow off paved surfaces.

⚠ WARNING

Exceeding any load limit or improperly loading your vehicle and trailer can cause a crash in which you can be seriously hurt or killed.

Check the loading of your vehicle and trailer carefully before starting to drive.

Load Limits

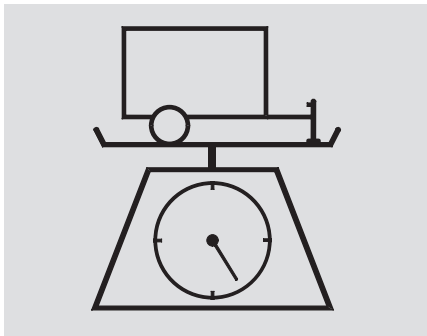

Total Trailer Weight: The maximum allowable weight of the trailer and everything in or on it must not exceed 1,500 lbs (680 kg). Towing a load that is too heavy can seriously affect your vehicle's handling and performance. It can also damage the engine and drivetrain.

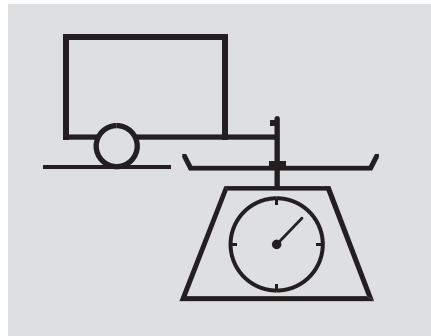

Tongue Load: The weight that the tongue of a fully-loaded trailer puts on the hitch should be approximately 10 percent of the total trailer weight. Too much tongue load reduces front-tire traction and steering control. Too little tongue load can make the trailer unstable and cause it to sway.

To achieve a proper tongue load, start by loading 60 percent of the load toward the front of the trailer and 40 percent toward the rear, then re-adjust the load as needed.

Gross Vehicle Weight Rating

(GVWR) – The maximum allowable weight of the vehicle, all occupants, all accessories, all cargo, and the tongue load is 4,450 lbs (2,020 kg).

Gross Axle Weight Ratings

(GAWR) – The maximum allowable weight of the vehicle, all occupants, all accessories, all cargo, and the tongue load must not exceed 2,200 lbs (1,000 kg) on the front axle, and 2,290 lbs (1,040 kg) on the rear axle.

Gross Combined Weight Rating

(GCWR) – The maximum allowable weight of the fully loaded vehicle and trailer is 5,950 lbs (2,700

kg)

Checking Loads

The best way to confirm that vehicle and trailer weights are within limits is to have them checked at a public scale.

Using a suitable scale or a special tongue load gauge, check the tongue load the first time you set up a towing combination (a fully-loaded vehicle and trailer), then recheck the tongue load whenever the conditions change.

Towing Equipment and Accessories

Towing can require a variety of equipment, depending on the size of your trailer, how it will be used, how much load you are towing, and where you tow.

Discuss your needs with your trailer sales or rental agency, and follow the guidelines in this section. Also make sure that all equipment is properly installed and maintained, and that it meets federal, state, province, and local regulations.

Hitches

Any hitch used on your vehicle must be properly bolted to the underbody.

Safety Chains

Always use safety chains when you tow a trailer. Make sure the chains are secured to the trailer and hitch, and that they cross under the tongue and can catch the trailer if it becomes unhitched. Leave enough slack to allow the trailer to turn corners easily, but do not let the chains drag on the ground.

CONTINUED

Towing a Trailer

Trailer Brakes

Honda requires that any trailer with a total weight of 1,000 lbs (455 kg) or more be equipped with its own electric or surge-type brakes.

If you choose electric brakes, be sure they are electrically actuated. Do not attempt to tap into your vehicle's hydraulic system. No matter how successful it may seem, any attempt to attach trailer brakes to your vehicle's hydraulic system will lower braking effectiveness and create a potential hazard.

See your trailer dealer for more information on installing electric brakes.

Trailer Lights

Trailer lights and equipment must comply with federal, state, province, and local regulations. Check with your local trailer sales or rental agencies for the requirements in your area where you plan to tow, and use only equipment designed for your vehicle.

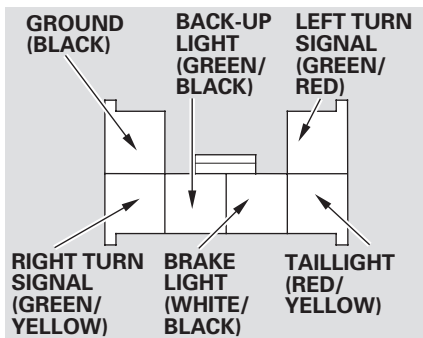

Your vehicle has a trailer lighting connector located behind the left side panel in the cargo area. Refer to the drawing above for the wiring color code and purpose of each pin.

If you use a non-Honda trailer lighting harness and converter, you can get the connector and pins that mate with the connector in your vehicle from your dealer.

Since lighting and wiring vary by trailer type and brand, you should have a qualified technician install a suitable connector between the vehicle and the trailer. Improper equipment or installation can cause damage to your vehicle's electrical system and affect your vehicle warranty.

Additional Towing Equipment

Many states and Canadian provinces require special outside mirrors when towing a trailer. Even if they don't, you should install special mirrors if you cannot clearly see behind you, or if the trailer creates a blind spot.

Ask your trailer sales or rental agency if any other items are recommended or required for your towing situation.

Pre-Tow Checklist

When preparing to tow, and before driving away, be sure to check the following:

- The vehicle has been properly serviced, and the tires, brakes, suspension, cooling system, and lights are in good operating condition.
(If you tow frequently, follow the severe conditions maintenance schedule.)
- The trailer has been properly serviced and is in good condition.
- All weights and loads are within limits.
- The hitch, safety chains, and any other attachments are secure.
- All items in or on the trailer are properly secured and cannot shift while you drive.

- The lights and brakes on your vehicle and the trailer are working properly.
- Your vehicle tires and spare are properly inflated, and the trailer tires and spare are inflated as recommended by the trailer maker.

Driving Safely With a Trailer

The added weight, length, and height of a trailer will affect your vehicle's handling and performance, so driving with a trailer requires some special driving skills and techniques.

For your safety and the safety of others, take time to practice driving maneuvers before heading for the open road, and follow the guidelines in this section.

CONTINUED

Towing a Trailer

Towing Speeds and Gears

Drive slower than normal in all driving situations, and obey posted speed limits for vehicles with trailers. If you have an automatic transmission, use the D3 mode when towing a trailer on level roads or in hilly terrain (see page 163).

Making Turns and Braking

Make turns more slowly and wider than normal. The trailer tracks a smaller arc than your vehicle, and it can hit or run over something the vehicle misses. Allow more time and distance for braking. Do not brake or turn suddenly as this could cause the trailer to jackknife or turn over.

Driving on Hills

When climbing hills, closely watch your temperature gauge. If it nears the red (hot) mark, turn the air conditioning off, reduce speed and, if necessary, pull to the side of the road to let the engine cool.

When driving down hills, reduce your speed and shift down to 3rd gear on the manual transmission, or use the D3 position on the automatic transmission. Do not “ride” the brakes, and remember it will take longer to slow down and stop when towing a trailer.

If you must stop when facing uphill, use the foot brake or parking brake. Do not try to hold the vehicle in place by pressing on the accelerator, as this can cause the automatic transmission to overheat.

Handling Crosswinds and Buffeting

Crosswinds and air turbulence caused by passing trucks can disrupt your steering and cause the trailer to sway. When being passed by a large vehicle, keep a constant speed, and steer straight ahead. Do not try to make quick steering or braking corrections.

Backing Up

Always drive slowly and have someone guide you when backing up. Grip the *bottom* of the steering wheel; then turn the wheel to the left to get the trailer to move to the left, and turn the wheel right to move the trailer to the right.

Parking

Follow all normal precautions when parking, including firmly setting the parking brake and putting the transmission in Park (automatic) or in 1st or reverse (manual). Also, place wheel chocks at each of the trailer’s tires.

Your vehicle can be towed behind a motorhome at legal highway speeds up to 65 mph (100 km/h). Do not exceed 65 mph (100 km/h).

Otherwise, severe transmission damage will occur. To avoid damage to the 4WD system, your vehicle must be towed with all four wheels on the ground (flat towing).

When purchasing a tow bar, make sure you select a reputable manufacturer and installer. Follow the manufacturer's attachment instructions carefully.

Perform the following procedure every day immediately before you begin towing. Otherwise severe automatic transmission damage will occur.

On models with automatic transmission

- Check the transmission fluid level (see page 199). *Do not overfill.*
- Start the engine.

- Press on the brake pedal. Move the shift lever through all its positions.
- Shift to D, then to N. Let the engine run for 3 minutes, then turn it off.
- Release the parking brake.
- Leave the ignition switch in the ACCESSORY (I) position so the steering wheel does not lock. Make sure the radio and any items plugged into the accessory power sockets are turned off so you do not run down the battery.

When you stop towing your vehicle and shift out of the neutral position, you may not be able to move the shift lever from neutral to reverse or Park. If this happens, press the brake pedal and turn the ignition switch to the ON (II) position, then shift out of neutral.

On models with manual transmission

- Check the transmission fluid level (see page 200). *Do not overfill.*
- Release the parking brake.
- Shift to neutral.
- Leave the ignition switch in the ACCESSORY (I) position so the steering wheel does not lock. Make sure the radio and any items plugged into the accessory power sockets are turned off so you do not run down the battery.

CONTINUED

Towing Your Vehicle Behind a Motorhome

NOTICE

The steering system can be damaged if the steering wheel is locked. Leave the ignition switch in the ACCESSORY (I) position, and make sure the steering wheel turns freely before you begin towing.

Extended Towing

If you tow more than 8 hours in one day, you should repeat the above procedure at least every 8 hours (when you stop for fuel, etc.)

NOTICE

Failure to follow the recommended instructions exactly will result in severe automatic transmission damage. If you cannot shift the transmission or start the engine, your vehicle must be transported on a flat-bed truck or trailer.

Automatic Transmission Extended Towing

When towing your vehicle for long periods, remove the 15 A Front Accessory Power Socket fuse to reduce drain on battery. This fuse is located in the interior fuse box and is shown as number 18 below.

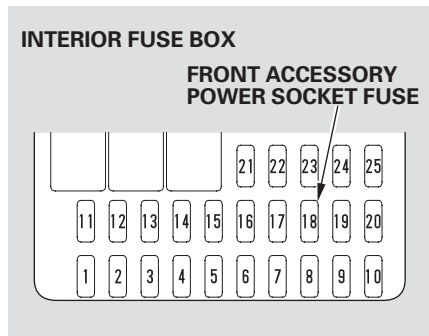

Only remove the fuse after you have performed the transmission shifting procedure, and the key is in the ACCESSORY (I) position. Store the fuse in an obvious location (center

tray, coin pockets, etc) as a reminder to re-install the fuse before driving the vehicle.

NOTICE

This fuse MUST be re-installed before driving the vehicle. Failure to re-install the fuse may allow you to remove the key with the transmission in gear.

NOTICE

Severe automatic transmission damage will occur if the vehicle is shifted from reverse to neutral and then towed with the drive wheels on the ground.

If you tow a CR-V with an automatic transmission, the transmission fluid must be changed every two years or 30,000 miles (48,000 km), whichever comes first.

General Information

Your vehicle has been designed primarily for use on pavement. But its higher ground clearance allows you to occasionally travel on unpaved roads, such as campgrounds, picnic sites, and similar locations. It is not designed for trail-blazing, mountain climbing, or other challenging off-road activities.

If you decide to drive on unpaved roads, you will find that it requires somewhat different driving skills. Your vehicle will also handle somewhat differently than it does on pavement. So be sure to read this owner's manual, pay special attention to the precautions and tips in this section, and get acquainted with your vehicle before you leave the pavement.

WARNING

Improperly operating this vehicle on or off pavement can cause an accident or rollover in which you and your passengers could be seriously injured or killed.

- Follow all instructions and guidelines in this owner's manual.
- Keep your speed low, and don't drive faster than conditions permit.

Important Safety Precautions

To avoid loss of control or rollover, be sure to follow all precautions and recommendations.

- Be sure to store cargo properly, and do not exceed your vehicle cargo load limits (see pages [151](#) and [172](#)).
- Wherever you drive, make sure you and your passengers always wear seat belts.
- Keep your speed low, and never go faster than the conditions allow.
- It's up to you to continually assess the situation and drive within the limits.

Off-Highway Driving Guidelines

Check Out Your Vehicle

Before you leave the pavement, be sure to do all scheduled maintenance and service, and inspect your vehicle for any problems. Pay special attention to the condition of the tires, and check the tire pressures.

After you return to the pavement, carefully inspect your vehicle to make sure there is no damage that could make driving it unsafe. Recheck the condition of the tires and the tire pressures.

Remember

The route presents limits (too steep or bumpy roads). You have limits (driving skill and comfort). And your vehicle has limits (traction, stability, and power).

Driving off-highway can be hazardous if you fail to recognize limits and take the proper precautions.

Accelerating and Braking

For better traction on all surfaces, accelerate slowly and gradually build up speed. If you try to start too fast on wet soil, mud, snow, or ice, you might not have enough traction to get underway, and you may dig yourself a hole. Starting with the shift lever in second (2) gear will help you have a smoother start on snow or ice.

Keep in mind that you will usually need more time and distance to brake to a stop on unpaved surfaces. Avoid hard braking. Do not “pump” the brakes; let the anti-lock braking system pump them for you.

Avoiding Obstacles

Debris in the road can damage your suspension or other components. Because your vehicle has a high center of gravity, driving over a large obstacle, or allowing a wheel to drop into a deep hole can cause your vehicle to tip or roll over.

Driving on Slopes

If you can't clearly see all conditions or obstacles on a slope, walk the slope before you drive on it. If you have any doubt whether or not you can safely drive on the slope, don't do it. Find another route.

If you are driving up a hill and find that you cannot continue, *do not try to turn around*. Your vehicle could roll over. Slowly back down the hill, following the same route you took up the hill.

Crossing a Stream

Avoid driving through deep water. If you encounter water in your route (a small stream or large puddle, for example), evaluate it carefully before going ahead. Make sure it is shallow, flowing slowly, and has firm ground underneath. If you are not sure of the depth or the ground, turn around and find another route.

Driving through deep water can also damage your vehicle. The water can get into the transmission and differential, diluting the lubricant and causing an eventual failure. It can also wash the grease out of the wheel bearings.

If You Get Stuck

Avoid driving on soft sand, deep mud, or other surfaces where you could get stuck. If you do happen to get stuck because of inclement weather or other conditions, choose a safe and appropriate course of action.

You should never use a jack to try getting unstuck. A jack only works on firm, level ground. Also, your vehicle could easily slip off the jack and hurt you or someone else.

4-Wheel Drive Vehicles

If you spin the wheels excessively trying to get unstuck, you may overheat the components of the 4-wheel drive system. If this happens, the 4-wheel drive system shuts off and only the front wheels receive power. If this happens, stop and allow everything to cool down. The 4-wheel drive system will work again after its temperature drops.

If you slip the clutch for a long time while trying to get unstuck, you may overheat and damage it.

This section explains why it is important to keep your vehicle well maintained and how to follow basic maintenance safety precautions.

This section also includes maintenance schedules for normal driving and severe driving conditions, a maintenance record, and instructions for simple maintenance tasks you may want to take care of yourself.

If you have the skills and tools to perform more complex maintenance tasks on your vehicle, you may want to purchase the service manual. See page [259](#) for information on how to obtain a copy, or see your dealer.

Maintenance Safety.....	184
Maintenance Schedule.....	185
Maintenance Record.....	189
Fluid Locations.....	192
Adding Engine Oil.....	193
Changing the Oil and Filter.....	194
Engine Coolant.....	196
Windshield Washers.....	198
Transmission Fluid.....	199
Automatic Transmission	
Fluid.....	199
Manual Transmission Fluid.....	200
Rear Differential Fluid.....	201
Brake and Clutch Fluid.....	201
Power Steering Fluid.....	202
Lights.....	203
Cleaning the Seat Belts.....	208
Floor Mats.....	208
Audio Antenna.....	209
Dust and Pollen Filter.....	209
Wiper Blades.....	210
Tires.....	211
Checking the Battery.....	217
Vehicle Storage.....	218

Maintenance Safety

All service items not detailed in this section should be performed by a certified technician or other qualified mechanic.

Important Safety Precautions

To eliminate potential hazards, read the instructions before you begin, and make sure you have the tools and skills required.

- Make sure your vehicle is parked on level ground, the parking brake is set, and the engine is off.
- To clean parts, use a commercially available degreaser or parts cleaner, not gasoline.
- To reduce the possibility of fire or explosion, keep cigarettes, sparks, and flames away from the battery and all fuel-related parts.
- Wear eye protection and protective clothing when working with the battery or compressed air.

WARNING

Improperly maintaining this vehicle, or failing to correct a problem before driving can cause a crash in which you can be seriously hurt or killed.

Always follow the inspection and maintenance recommendations and schedules in this owner's manual.

Potential Vehicle Hazards

- **Carbon Monoxide poison from engine exhaust.** Be sure there is adequate ventilation whenever you operate the engine.
- **Burns from hot parts.** Let the engine and exhaust system cool before touching any parts.

- **Injury from moving parts.** Do not run the engine unless instructed to do so.

WARNING

Failure to properly follow maintenance instructions and precautions can cause you to be seriously hurt or killed.

Always follow the procedures and precautions in this owner's manual.

Some of the most important safety precautions are given here. However, we cannot warn you of every conceivable hazard that can arise in performing maintenance. Only you can decide whether or not you should perform a given task.

The maintenance schedule assumes you will use your vehicle as normal transportation for passengers and their possessions. You should also follow these recommendations:

- Avoid exceeding your vehicle's load limit. This puts excess stress on the engine, brakes, and many other vehicle parts. The load limit is shown on the tire information label on the driver's doorjamb.
- Operate your vehicle on reasonable roads within the legal speed limit.
- Drive your vehicle regularly over a distance of several miles (kilometers).
- Always use unleaded gasoline with the proper octane rating (see page 142).

Which Schedule to Follow:

Service your vehicle according to the time and mileage periods on one of the maintenance schedules on the following pages.

U.S. Owners — Follow the maintenance schedule for severe conditions if you drive your vehicle **MAINLY** under one or more of the following conditions:

- Driving less than 5 miles (8 km) per trip, in freezing temperatures, or driving less than 10 miles (16 km) per trip.
- Driving in extremely hot [over 90°F (32°C)] conditions.
- Extensive idling or long periods of stop-and-go driving, such as a taxi or a commercial delivery vehicle.

- Trailer towing, driving with a loaded roof rack, or driving in mountainous conditions.
- Driving on muddy, dusty, or de-iced roads.

NOTE: If you only **OCCASIONALLY** drive under a “severe” condition, you should follow the maintenance schedule for normal conditions.

Canadian Owners — Follow the maintenance schedule for severe conditions.

Maintenance Schedule

Servicing Your Vehicle

Your authorized dealer knows your vehicle best and can provide competent, efficient service.

However, service at a dealer is not mandatory to keep your warranties in effect. Maintenance may be done by any qualified service facility or skilled person to keep your warranties in effect. Keep all the receipts as proof of completion, and have the person who does the work fill out the maintenance record. Check your warranty booklet for more information.

We recommend the use of Honda parts and fluids whenever you have maintenance done.

U.S. Vehicles: Maintenance, replacement, or repair of emissions control devices and systems may be done by any automotive repair establishment or individual using parts that are “certified” to EPA standards.

According to state and federal regulations, failure to perform maintenance on the items marked with # will not void your emissions warranties. However, all maintenance services should be performed at the recommended time or mileage period to ensure long-term reliability.

Owner's Maintenance Checks

You should check the following items at the specified intervals. If you are unsure of how to perform any check, turn to the appropriate page listed.

- Engine oil level — Check every time you fill the fuel tank. See page [145](#) .
- Engine coolant level — Check the radiator reserve tank every time you fill the fuel tank. See page [146](#) .
- Automatic transmission — Check the fluid level monthly. See page [199](#) .
- Brakes — Check the fluid level monthly. See page [201](#) .
- Tires — Check the tire pressure monthly. Examine the tread for wear and foreign objects. See page [212](#) .
- Lights — Check the operation of the headlights, parking lights, taillights, high-mount brake light, and license plate light monthly. See page [203](#) .

Service the items listed at the indicated distance (or time, if given).																
	miles x 1,000	10	20	30	40	50	60	70	80	90	100	110	120	130	140	150
	km x 1,000	16	32	48	64	80	96	112	128	144	160	176	192	208	224	240
Check engine oil and coolant	Check oil and coolant at each fuel stop															
Check tires	Check inflation and condition once a month															
Replace engine oil	Every 10,000 miles (16,000 km) or every 1 year, whichever comes first															
Rotate tires (follow pattern on page 214)	Every 10,000 miles (16,000 km)															
Replace engine oil filter Check front and rear brakes Check parking brake adjustment Inspect the following items: Tie-rod ends, steering gearbox, and boots Suspension components Driveshaft boots Brake hoses and lines (including ABS) All fluid levels and condition of fluids Exhaust system [#] Fuel lines and connections [#]	Every 20,000 miles (32,000 km) or every 1 year, whichever comes first															
Inspect drive belt Replace dust and pollen filter	Every 30,000 miles (48,000 km) or every 2 years, whichever comes first															
Replace air cleaner element				●			●			●			●			●
Replace spark plugs													●			
Inspect valve clearance	Inspect every 110,000 miles (176,000 km), otherwise adjust only if noisy															
Replace automatic transmission fluid*													●			
Replace manual transmission fluid	Every 120,000 miles (192,000 km) or every 6 years, whichever comes first															
Replace rear differential fluid	Every 90,000 miles (144,000 km) or every 5 years, whichever comes first															
Inspect idle speed	Every 160,000 miles (256,000 km)															
Replace engine coolant	At 120,000 miles (192,000 km) or 10 years, then every 60,000 miles (96,000 km) or 5 years															
Replace brake fluid	Every 3 years (independent of mileage)															

: See information on maintenance and emissions warranty, middle column, page 186.

* : Replace at 120,000 miles (192,000 km) or 6 years, then every 90,000 miles (144,000 km) or 5 years.

Service the items listed at the indicated distance (or time, if given).

	miles x 1,000	10	20	30	40	50	60	70	80	90	100	110	120	130	140	150
	km x 1,000	16	32	48	64	80	96	112	128	144	160	176	192	208	224	240
Check engine oil and coolant	Check oil and coolant at each fuel stop															
Check tires	Check inflation and condition once a month															
Replace engine oil	Every 5,000 miles (8,000 km) or every 6 months, whichever comes first															
Rotate tires (follow pattern on page 214)	Every 10,000 miles (16,000 km)															
Replace engine oil filter	Every 10,000 miles (16,000 km) or every 1 year, whichever comes first															
Check front and rear brakes																
Lubricate all hinges, locks and latches																
Inspect the following items:																
Tie-rod ends, steering gearbox, and boots																
Suspension components	Every 20,000 miles (32,000 km) or every 1 year, whichever comes first															
Driveshaft boots																
Check parking brake adjustment																
Inspect the following items:																
Brake hoses and lines (including ABS)																
All fluid levels and condition of fluids	Every 30,000 miles (48,000 km) or every 2 years, whichever comes first															
Exhaust system [#]																
Fuel lines and connections [#]																
Lights and controls/vehicle underbody																
Inspect drive belt																
Replace dust and pollen filter ^{*1}	Every 30,000 miles (48,000 km) or every 2 years, whichever comes first															
Clean and replace air cleaner element	Clean every 15,000 miles (24,000 km), and replace every 30,000 miles (48,000 km) (Use normal schedule except in dusty condition)															
Replace spark plugs													●			
Inspect valve clearance	Inspect every 110,000 miles (176,000 km), otherwise adjust only if noisy															
Replace automatic transmission fluid ^{*2}						●					●			●		●
Replace manual transmission fluid	Every 60,000 miles (96,000 km) or every 3 years, whichever comes first															
Replace rear differential fluid	Every 60,000 miles (96,000 km) or every 4 years, whichever comes first															
Inspect idle speed	Every 160,000 miles (256,000 km)															
Replace engine coolant	At 120,000 miles (192,000 km) or 10 years, then every 60,000 miles (96,000 km) or 5 years															
Replace brake fluid	Every 3 years (independent of mileage)															

: See information on maintenance and emissions warranty, middle column, page 186 .

* 1: See dust and pollen filter on page 209 for replacement information under special driving conditions.

* 2: Replace at 60,000 miles (96,000 km) or 3 years, then every 30,000 miles (48,000 km) or 2 years.

Maintenance Record *(for Normal and Severe Schedules)*

You or the servicing dealer can record all completed maintenance here, whether you follow the schedule for normal conditions (page 187) or severe conditions (page 188). Keep the receipts for all work done on your vehicle.

5,000 mi 8,000 km	Signature or dealer stamp	mi/km
		Date
10,000 mi 16,000 km		mi/km
		Date
15,000 mi 24,000 km		mi/km
		Date
20,000 mi 32,000 km		mi/km
		Date
25,000 mi 40,000 km		mi/km
		Date

30,000 mi 48,000 km	Signature or dealer stamp	mi/km
		Date
35,000 mi 56,000 km		mi/km
		Date
40,000 mi 64,000 km		mi/km
		Date
45,000 mi 72,000 km		mi/km
		Date
50,000 mi 80,000 km		mi/km
		Date

Maintenance Record *(for Normal and Severe Schedules)*

55,000 mi 88,000 km	Signature or dealer stamp	mi/km
		Date
60,000 mi 96,000 km		mi/km
		Date
65,000 mi 104,000 km		mi/km
		Date
70,000 mi 112,000 km		mi/km
		Date
75,000 mi 120,000 km		mi/km
		Date

80,000 mi 128,000 km	Signature or dealer stamp	mi/km
		Date
85,000 mi 136,000 km		mi/km
		Date
90,000 mi 144,000 km		mi/km
		Date
95,000 mi 152,000 km		mi/km
		Date
100,000 mi 160,000 km		mi/km
		Date

Maintenance Record *(for Normal and Severe Schedules)*

105,000 mi 168,000 km	Signature or dealer stamp	mi/km
		Date
110,000 mi 176,000 km		mi/km
		Date
115,000 mi 184,000 km		mi/km
		Date
120,000 mi 192,000 km		mi/km
		Date
125,000 mi 200,000 km		mi/km
		Date

130,000 mi 208,000 km	Signature or dealer stamp	mi/km
		Date
135,000 mi 216,000 km		mi/km
		Date
140,000 mi 224,000 km		mi/km
		Date
145,000 mi 232,000 km		mi/km
		Date
150,000 mi 240,000 km		mi/km
		Date

Fluid Locations

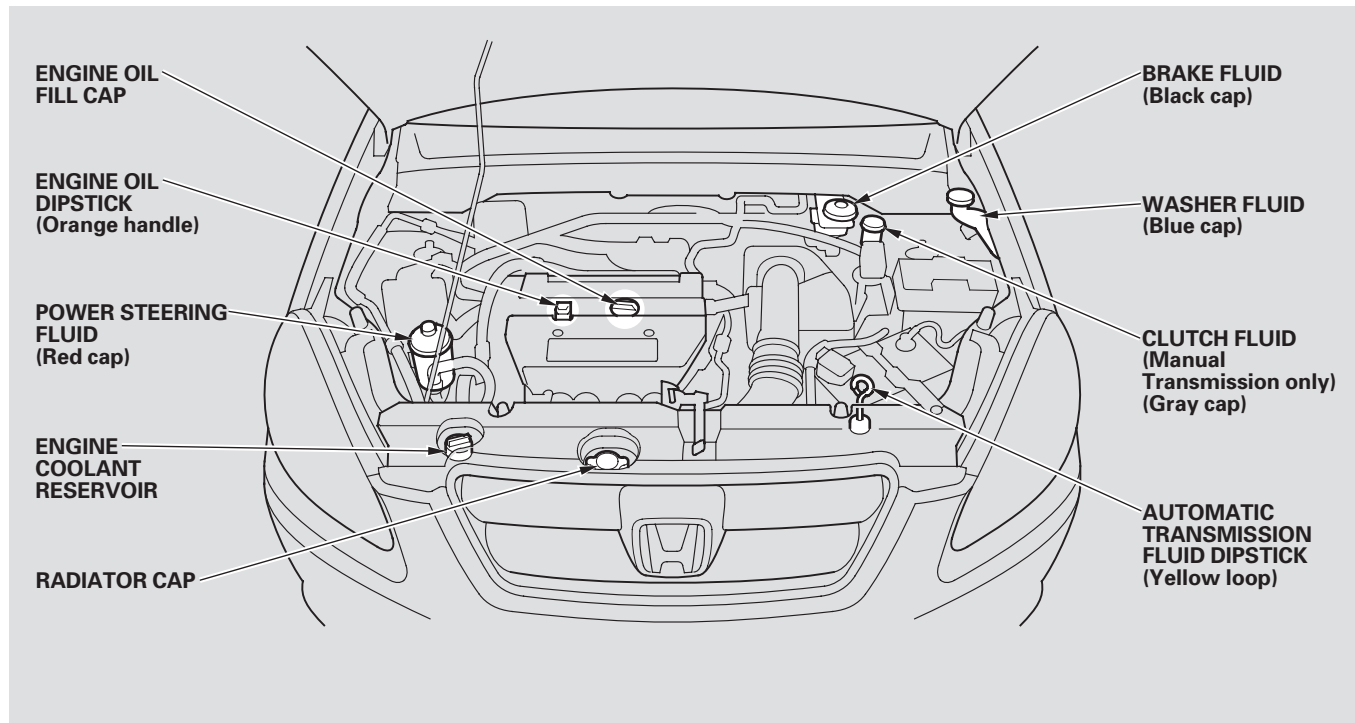

Adding Engine Oil

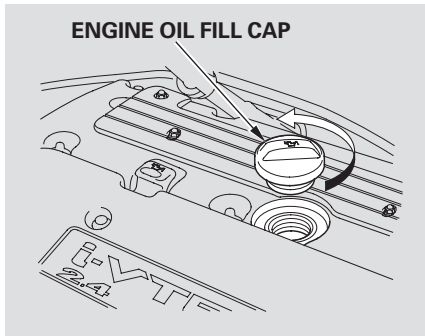

Unscrew and remove the engine oil fill cap on top of the valve cover. Pour in the oil slowly and carefully so you do not spill any. Clean up any spills immediately. Spilled oil could damage components in the engine compartment.

Reinstall the engine oil fill cap, and tighten it securely. Wait a few minutes, and recheck the oil level on the engine oil dipstick. Do not fill above the upper mark; you could

damage the engine.

Recommended Engine Oil

Oil is a major contributor to your engine's performance and longevity. Always use a premium-grade 5W-20 detergent oil displaying the API Certification Seal. This seal indicates the oil is energy conserving, and that it meets the American Petroleum Institute's latest requirements.



Honda Motor Oil is the preferred 5W-20 lubricant for your vehicle. It is highly recommended that you use Honda Motor Oil in your vehicle for optimum engine protection. Make sure the API Certification Seal says "For Gasoline Engines."

The oil viscosity or weight is provided on the container's label. 5W-20 oil is formulated for year-round protection of your vehicle to improve cold weather starting and fuel economy.

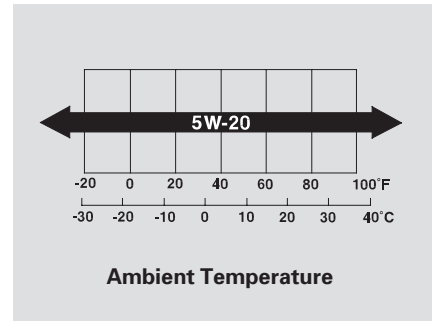

Adding Engine Oil, Changing the Oil and Filter

Synthetic Oil

You may use a synthetic motor oil if it meets the same requirements given for a conventional motor oil, it displays the API Certification Seal and it is the proper weight. You must follow the oil and filter change intervals given in the maintenance schedule.

Engine Oil Additives

Your vehicle does not require any oil additives. Additives may adversely affect the engine or transmission performance and durability.

Changing the Oil and Filter

Always change the oil and filter according to the recommendations in the maintenance schedule. The oil and filter collect contaminants that can damage your engine if they are not removed regularly.

Changing the oil and filter requires special tools and access from underneath the vehicle. The vehicle should be raised on a service station-type hydraulic lift for this service. Unless you have the knowledge and proper equipment, you should have this maintenance done by a skilled mechanic.

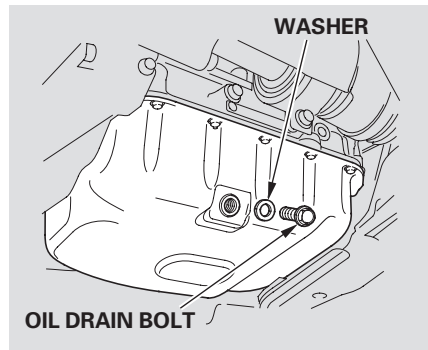

1. Run the engine until it reaches normal operating temperature, then shut it off.
2. Open the hood, and remove the engine oil fill cap. Remove the oil drain bolt and washer from the bottom of the engine. Drain the oil into an appropriate container.

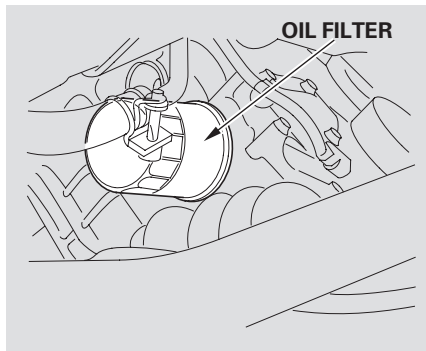

3. Remove the oil filter, and let the remaining oil drain. A special wrench (available from your dealer) is required.
4. Check the oil filter to make sure its gasket did not stick to the engine block. A stuck gasket could cause an oil leak.
5. Install a new oil filter according to the instructions that come with it.

6. Put a new washer on the drain bolt, then reinstall the drain bolt. Tighten the drain bolt to:
33 lbf·ft (44 N·m , 4.5 kgf·m)

7. Refill the engine with the recommended oil.

Engine oil change capacity
(including filter):
4.4 US qt (4.2 ℓ)

8. Replace the engine oil fill cap. Start the engine. The oil pressure indicator should go out within 5 seconds. If it does not, turn off the engine, and check your work.
9. Let the engine run for several minutes, then check the drain bolt and oil filter for leaks.
10. Turn off the engine and let it sit for several minutes, then check the oil level on the dipstick. If necessary, add more oil.

NOTICE

Improper disposal of engine oil can be harmful to the environment. If you change your own oil, please dispose of the used oil properly. Put it in a sealed container and take it to a recycling center. Do not discard it in a trash bin or dump it on the ground.

Engine Coolant

Adding Engine Coolant

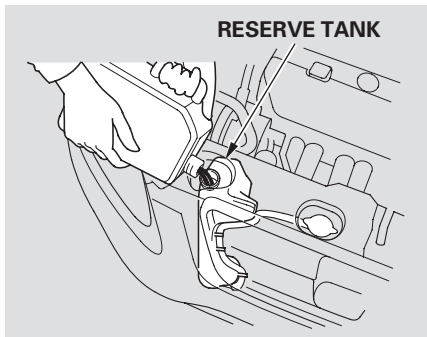

If the coolant level in the reserve tank is at or below the MIN line, add coolant to bring it up to the MAX line. Inspect the cooling system for leaks.

Always use Honda Long-life Antifreeze/Coolant Type 2. This coolant is pre-mixed with 50 percent antifreeze and 50 percent water. Never add straight antifreeze or plain water.

If Honda antifreeze/coolant is not available, you may use another major-brand non-silicate coolant as a temporary replacement. Make sure it is a high-quality coolant recommended for aluminum engines. Continued use of any non-Honda coolant can result in corrosion, causing the cooling system to malfunction or fail. Have the cooling system flushed and refilled with Honda antifreeze/coolant as soon as possible.

If the reserve tank is completely empty, you should also check the coolant level in the radiator.

⚠ WARNING

Removing the radiator cap while the engine is hot can cause the coolant to spray out, seriously scalding you.

Always let the engine and radiator cool down before removing the radiator cap.

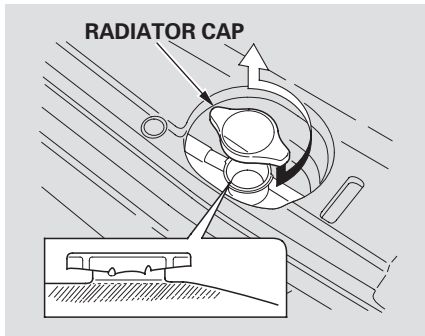

1. When the radiator and engine are cool, relieve any pressure in the cooling system by turning the radiator cap counterclockwise, without pressing down.
2. Remove the radiator cap by pushing it down and turning it counterclockwise.

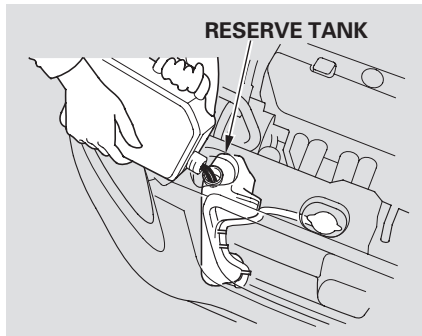

3. The coolant level should be up to the base of the filler neck. Add coolant if it is low.

Pour the coolant slowly and carefully so you do not spill any. Clean up any spill immediately; it could damage components in the engine compartment.

4. Put the radiator cap back on and tighten it.

5. Pour coolant into the reserve tank. Fill it halfway between the MAX and MIN marks. Put the cap back on the reserve tank.

Do not add any rust inhibitors or other additives to your vehicle's cooling system. They may not be compatible with the coolant or engine components.

Windshield Washers

Check the fluid level in the windshield washer reservoir at least monthly during normal use.

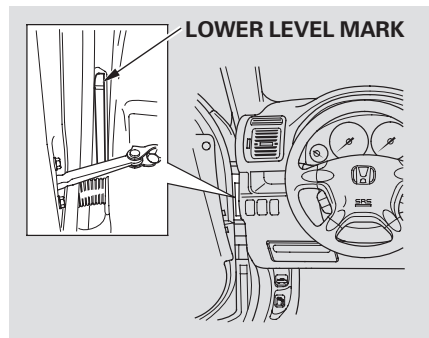

To check the windshield washer fluid level, open the driver's door, then look at the side of the reservoir tank located between the door and the front dashboard.

On Canadian models: The low washer level indicator comes on when the level is low (see page 60).

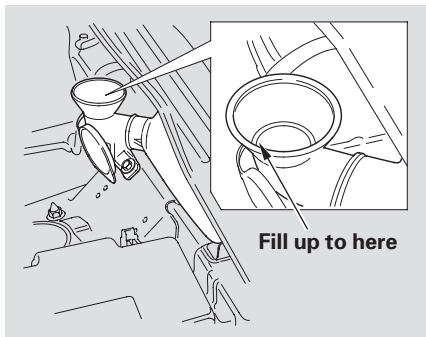

If the fluid level is below the lower level mark, fill the reservoir with windshield washer fluid.

Fill the reservoir with a good-quality windshield washer fluid. This increases the cleaning capability and prevents freezing in cold weather.

When you refill the reservoir, clean the edges of the windshield wiper blades with windshield washer fluid

on a clean cloth. This will help to condition the blade edges.

NOTICE

Do not use engine antifreeze or a vinegar/water solution in the windshield washer reservoir. Antifreeze can damage your vehicle's paint, while a vinegar/water solution can damage the windshield washer pump. Use only commercially-available windshield washer fluid.

Automatic Transmission Fluid

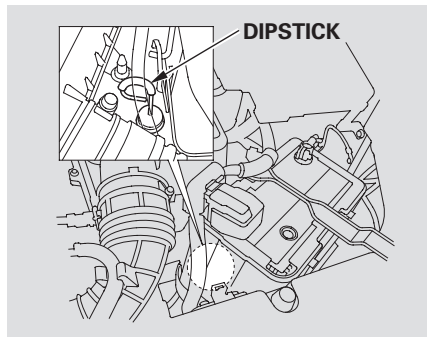

Check the fluid level with the engine at normal operating temperature.

1. Park the vehicle on level ground. Shut off the engine.
2. Remove the dipstick (yellow loop) from the transmission, and wipe it with a clean cloth.

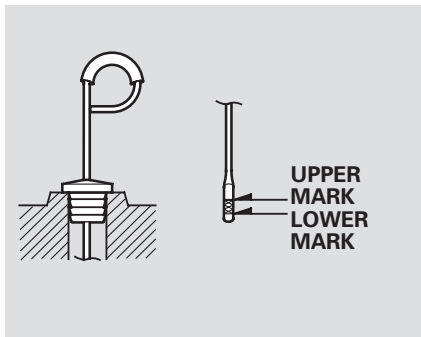

3. Insert the dipstick all the way into the transmission securely as shown in the illustration.
4. Remove the dipstick and check the fluid level. It should be between the upper and lower marks.
5. If the level is below the lower mark, add fluid into the filler hole to bring it to the upper mark.

Pour the fluid slowly and carefully so you do not spill any. Clean up any spill immediately; it could damage components in the engine compartment.

Always use Honda ATF-Z1 (automatic transmission fluid). If it's not available, you may use a DEXRON® III automatic transmission fluid as a temporary replacement. However, continued use can affect the shift quality. Have the transmission flushed and refilled with Honda ATF-Z1 as soon as it is convenient.

To thoroughly flush the transmission, the technician should drain and refill it with Honda ATF-Z1, then drive the vehicle for a short distance. Do this three times. Then drain and refill the transmission a final time.

CONTINUED

Transmission Fluid

6. Insert the dipstick all the way back into the transmission securely as shown in the illustration.

The transmission should be drained and refilled with new fluid according to the time and distance recommendations in the maintenance schedule.

If you are not sure how to add fluid, contact your dealer.

Manual Transmission Fluid

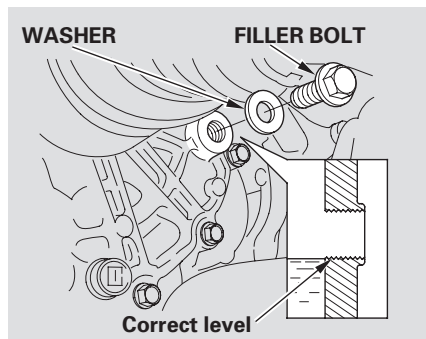

Check the fluid level with the transmission at normal operating temperature and the vehicle sitting on level ground. Remove the transmission filler bolt and carefully feel inside the bolt hole with your finger. The fluid level should be up to the edge of the bolt hole. If it is not, add Honda Manual Transmission Fluid (MTF) until it starts to run out of the hole.

Put a new washer on the filler bolt, then reinstall the filler bolt and tighten it securely.

If Honda MTF is not available, you may use an SAE 10W-30 or 10W-40 viscosity motor oil with the API Certification seal that says "FOR GASOLINE ENGINES" as a temporary replacement. However, motor oil does not contain the proper additives, and continued use can cause stiffer shifting. Replace as soon as it is convenient.

The transmission should be drained and refilled with new fluid according to the time and distance recommendations in the maintenance schedule.

If you are not sure how to check and add fluid, contact your dealer.

Rear Differential Fluid

4WD model only

The rear differential should be drained and refilled with new fluid according to the time and distance recommendations in the maintenance schedule. Have your dealer replace the rear differential fluid.

Use Honda Dual Pump Fluid only. Do not use automatic transmission fluid (ATF).

Brake and Clutch Fluid

Check the brake fluid level in the reservoirs monthly.

Replace the brake fluid according to the time recommendation in the maintenance schedule.

Always use Honda Heavy Duty Brake Fluid DOT 3. If it is not available, you should use only DOT 3 or DOT 4 fluid, from a sealed container, as a temporary replacement.

Using any non-Honda brake fluid can cause corrosion and decrease the life of the system. Have the brake system flushed and refilled with Honda Heavy Duty Brake Fluid DOT 3 as soon as possible.

Brake fluid marked DOT 5 is not compatible with your vehicle's braking system and can cause extensive damage.

Brake Fluid

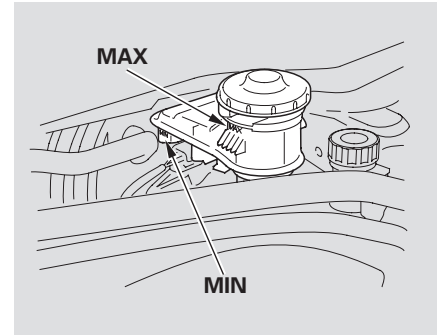

The fluid level should be between the MIN and MAX marks on the side of the reservoir. If the level is at or below the MIN mark, your brake system needs attention. Have the brake system inspected for leaks or worn brake pads.

Brake and Clutch Fluid, Power Steering Fluid

Clutch Fluid

Manual Transmission only

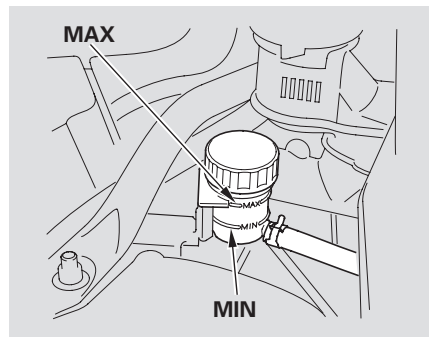

The fluid level should be between the MIN and MAX marks on the side of the reservoir. If it is not, add brake fluid to bring it up to that level. Use the same fluid specified for the brake system.

A low fluid level can indicate a leak in the clutch system. Have this system inspected as soon as possible.

Power Steering Fluid

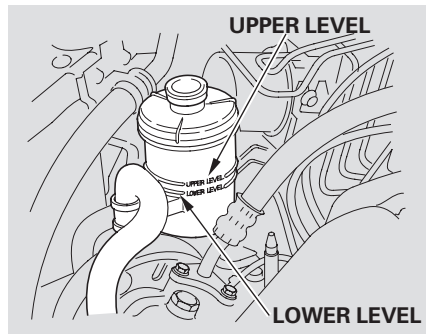

Check the level on the side of the reservoir when the engine is cold. The fluid should be between the UPPER LEVEL and LOWER LEVEL. If not, add power steering fluid to the UPPER LEVEL.

Pour the fluid slowly and carefully so you do not spill any. Clean up any spills immediately; it could damage components in the engine compartment.

Always use Honda Power Steering Fluid. You may use another power steering fluid as an emergency replacement, but have the power steering system flushed and refilled with Honda PSF as soon as possible.

A low power steering fluid level can indicate a leak in the system. Check the fluid level frequently, and have the system inspected as soon as possible.

NOTICE

Turning the steering wheel to full left or right lock and holding it there can damage the power steering pump.

Headlight Aiming

The headlights were properly aimed when your vehicle was new. If you regularly carry heavy items in the cargo area or pull a trailer, readjustment may be required. Adjustments should be done by your dealer or other qualified mechanic.

Replacing a Headlight Bulb

Your vehicle has halogen headlight bulbs. When replacing a bulb, handle it by its base, and protect the glass from contact with your skin or hard objects. If you touch the glass, clean it with denatured alcohol and a clean cloth.

NOTICE

Halogen headlight bulbs get very hot when lit. Oil, perspiration, or a scratch on the glass can cause the bulb to overheat and shatter.

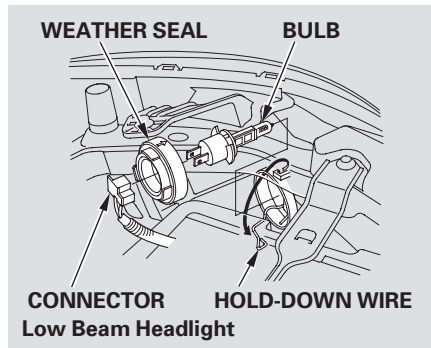

1. Remove the electrical connector from the bulb by pulling the connector straight back.
2. Remove the rubber weather seal by pulling on the tab.
3. Unclip the end of the hold-down wire from its slot. Pivot it out of the way, and remove the bulb.

CONTINUED

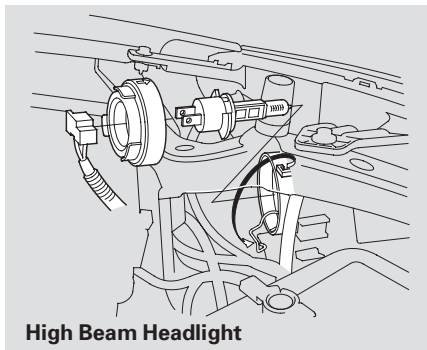

4. Install the new bulb into the hole, making sure the tabs are in their slots. Pivot the hold-down wire back in place, and clip the end into the slot.

5. Install the rubber seal over the back of the headlight assembly. Make sure it is right side up; it is marked “→.”
6. Push the electrical connector onto the new bulb. Make sure it is connected securely. Turn on the headlights to test the new bulb.

Replacing a Parking Light/Front Side Marker Bulb and a Turn Signal Light Bulb

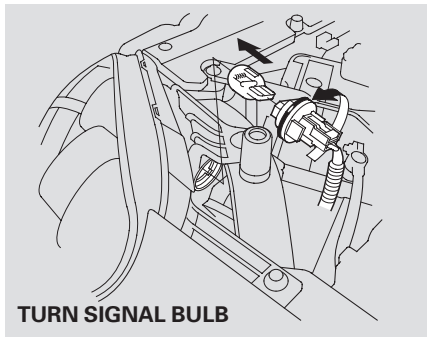

1. Open the hood.
2. Remove the socket from the headlight assembly by turning it one-quarter turn counterclockwise.
3. Pull the bulb straight out of its socket. Push the new bulb straight into the socket until it bottoms.

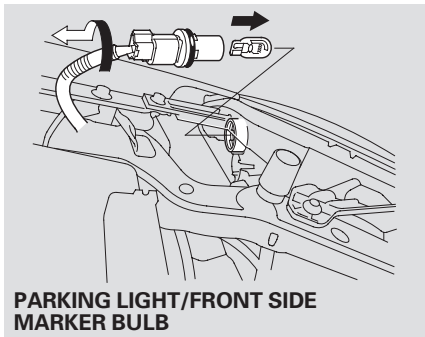

4. Insert the socket back into the headlight assembly. Turn it clockwise to lock it in place.
5. Turn on the lights to make sure the new bulb is working.

Replacing Rear Bulbs

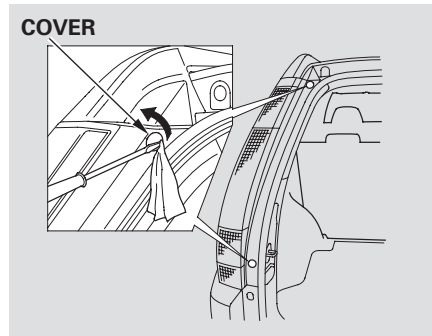

1. Open the tailgate. Place a cloth on the edge of the cover. Remove the covers by carefully prying on the edge with a small flat-tipped screwdriver.

CONTINUED

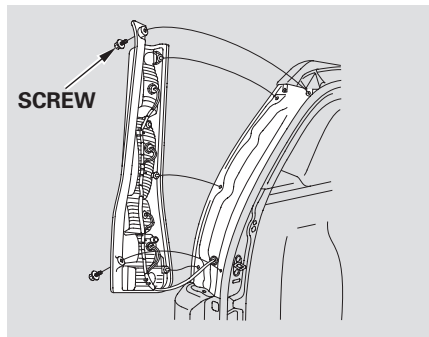

2. Use a Phillips-head screwdriver to remove the taillight assembly mounting screw under each cover.
3. Pull the taillight assembly out of the rear pillar.

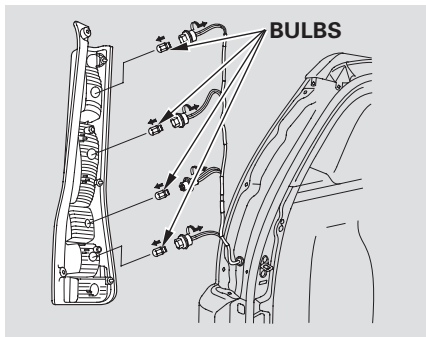

4. Determine which of the four bulbs is burned out: stop/taillight, back-up light, turn signal, or side marker.
5. Remove the socket by turning it one-quarter turn counterclockwise.

6. Pull the bulb straight out of its socket. Push the new bulb straight into the socket until it bottoms.
7. Reinstall the socket into the light assembly by turning it clockwise until it locks.
8. Turn on the lights to make sure the new bulb is working.
9. Align the clips on the taillight assembly with the holes in the body, then push the taillight assembly into place. Tighten the two mounting screws securely and reinstall the covers.

Replacing a High-mount Brake Light Bulb

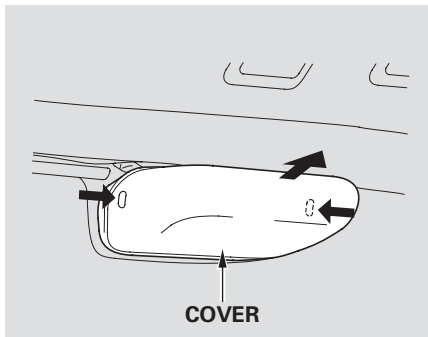

1. Open the tailgate. Remove the light assembly cover by pushing in on the tabs on both sides and pulling the cover off.
2. Remove the socket from the light assembly by turning it one-quarter turn counterclockwise.

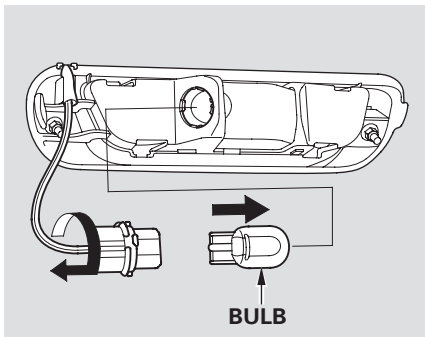

3. Pull the bulb straight out of its socket. Push the new bulb straight into the socket until it bottoms.
4. Press the brake pedal to make sure the new bulb is working.

5. Put the socket back into the light assembly, and turn it clockwise to lock it in place.
6. Put the cover back on the light assembly. Push it in until it locks in place.

Cleaning the Seat Belts, Floor Mats

Cleaning the Seat Belts

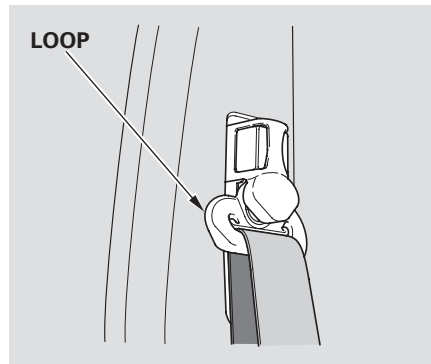

If your seat belts get dirty, use a soft brush with a mixture of mild soap and warm water to clean them. Do not use bleach, dye, or cleaning solvents. Let the belts air-dry before you use the vehicle.

Dirt build-up in the loops of the seat belt anchors can cause the belts to retract slowly. Wipe the insides of the loops with a clean cloth dampened in mild soap and warm water or isopropyl alcohol.

Floor Mats

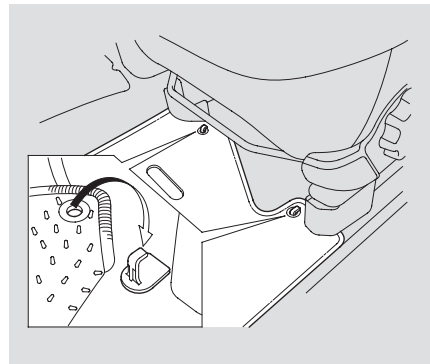

The driver's and the rear floor mats that came with your vehicle hook over the floor mat anchors. This keeps the floor mat from sliding forward and possibly interfering with the pedals or making the front passenger's weight sensors ineffective.

If you remove a floor mat, make sure to re-anchor it when you put it back in your vehicle.

If you use a non-Honda floor mat, make sure it fits properly and that it can be used with the floor mat anchors. Do not put additional floor mats on top of the anchored mats.

Make sure the rear floor mats are properly hooked to the floor mat anchors. Your vehicle is equipped with front passenger's seat weight sensors. If the rear passenger's floor mat is on the seat rail of the front passenger's seat, the sensors will detect the decreased weight on the seat, and they may not work properly.

Audio Antenna

NOTICE

Your vehicle is equipped with an antenna on the front right fender. Before using a "drive-through" car wash, make sure you remove the antenna by unscrewing it by hand. This prevents the antenna from being damaged by the car wash brushes.

Dust and Pollen Filter

This filter removes the dust and pollen that is brought in from the outside through the heating and cooling system.

Have your dealer replace this filter every 30,000 miles (48,000 km) under normal conditions. It should be replaced every 15,000 miles (24,000 km) if you drive primarily in urban areas that have high concentrations of soot in the air, or if the flow from the heating and cooling system becomes less than usual.

Wiper Blades

Check the condition of the wiper blades at least every six months. Replace them if you find signs of cracking in the rubber, areas that are getting hard, or if they leave streaks and unwiped areas when used.

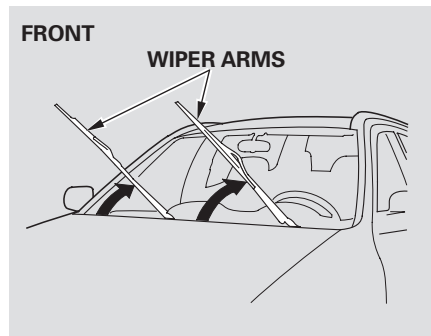

1. Front:
Raise the wiper arm off the windshield.

NOTICE

Do not open the hood when the wiper arms are raised, or you will damage the hood and the wiper arms.

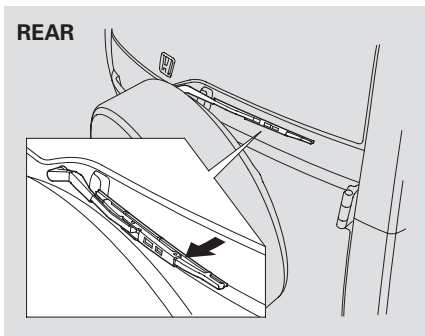

- Rear:
Raise the wiper arm off the hatch glass and hold it.

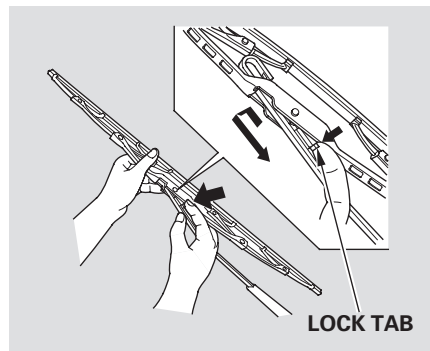

2. Disconnect the blade assembly from the wiper arm by pushing in the lock tab. Hold the lock tab in while you push the blade assembly toward the base of the arm.

If you are changing the rear wiper blade, go to step 6.

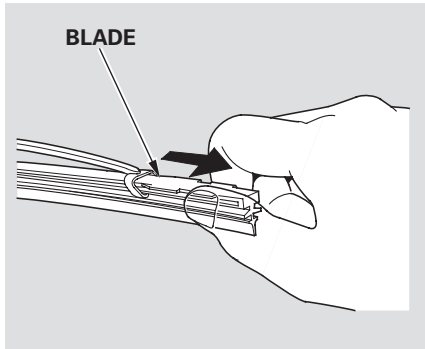

3. Remove the blade from its holder by grasping the tabbed end of the blade. Pull firmly until the tabs come out of the holder.
4. Examine the new wiper blades. If they have no plastic or metal reinforcement along the back edge, remove the metal reinforcement strips from the old wiper blade, and install them in the slots along the edge of the new blade.

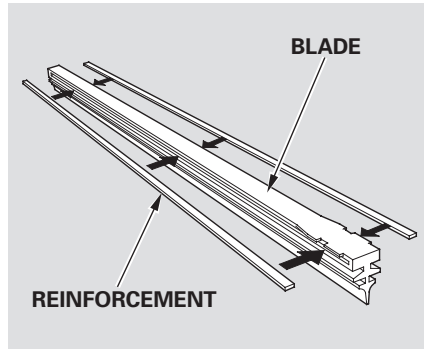

5. Slide the new wiper blade into the holder until the tabs lock.
6. Slide the wiper blade assembly onto the wiper arm. Make sure it locks in place.
7. Lower the wiper arm down against the windshield or the hatch glass.

Tires

To safely operate your vehicle, your tires must be the proper type and size, in good condition with adequate tread, and correctly inflated.

The following pages give more detailed information on how to take care of your tires and what to do when they need to be replaced.

⚠ WARNING

Using tires that are excessively worn or improperly inflated can cause a crash in which you can be seriously hurt or killed.

Follow all instructions in this owner's manual regarding tire inflation and maintenance.

CONTINUED

Inflation Guidelines

Keeping the tires properly inflated provides the best combination of handling, tread life, and riding comfort.

- Underinflated tires wear unevenly, adversely affect handling and fuel economy, and are more likely to fail from being overheated.
- Overinflated tires can make your vehicle ride more harshly, are more prone to damage from road hazards, and wear unevenly.

We recommend that you visually check your tires every day. If you think a tire might be low, check it immediately with a tire gauge.

Use a gauge to measure the air pressure in each tire at least once a month. Even tires that are in good condition may lose 1 to 2 psi (10 to 20 kPa, 0.1 to 0.2 kgf/cm²) per month. Remember to check the spare tire at the same time.

Check the air pressures when the tires are cold. This means the vehicle has been parked for at least 3 hours, or driven less than 1 mile (1.6 km). Add or release air, if needed, to match the recommended cold tire pressures on page [213](#).

If you check air pressures when the tires are hot [driven for several miles (kilometers)], you will see readings 4 to 6 psi (30 to 40 kPa, 0.3 to 0.4 kgf/cm²) higher than the cold readings. This is normal. Do not let air out to match the recommended cold air pressure. The tire will be underinflated.

You should use your own tire pressure gauge whenever you check your tire pressures. This will make it easier for you to tell if a pressure loss is due to a tire problem and not due to a variation between gauges.

While tubeless tires have some ability to self-seal if they are punctured, you should look closely for punctures if a tire starts losing pressure.

Recommended Tire Pressures

The following chart shows the recommended cold tire pressures for most normal and high-speed driving conditions.

Tire Size	Cold Tire Pressure for Normal Driving
215/65R16 98T	Front/Rear: 29 psi (200 kPa , 2.0 kgf/cm ²)

For convenience, the recommended tire sizes and cold tire pressures are on a label on the driver's doorjamb.

For additional information about your tires, see page [248](#).

Tire Inspection

Every time you check inflation, you should also examine the tires for damage, foreign objects, and wear.

You should look for:

- Bumps or bulges in the tread or side of the tire. Replace the tire if you find either of these conditions.
- Cuts, splits, or cracks in the side of the tire. Replace the tire if you can see fabric or cord.
- Excessive tread wear.

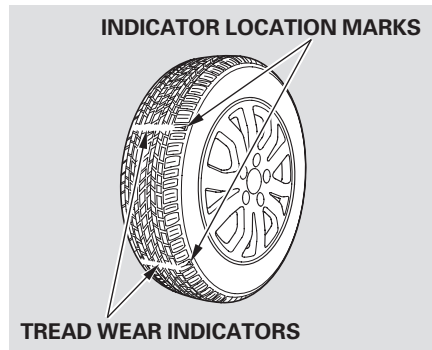

Your tires have wear indicators molded into the tread. When the tread wears down, you will see a band 1/2 inch (12.7 mm) wide across the tread. This shows there is less than 1/16 inch (1.6 mm) of tread left on the tire.

A tire this worn gives very little traction on wet roads. You should replace the tire if you can see three or more tread wear indicators.

Tires

Tire Maintenance

In addition to proper inflation, correct wheel alignment helps to decrease tire wear. If you find a tire is worn unevenly, have your dealer check the wheel alignment.

Have your dealer check the tires if you feel a consistent vibration while driving. A tire should always be rebalanced if it is removed from the wheel. When you have new tires installed, make sure they are balanced. This increases riding comfort and tire life. For best results, have the installer perform a dynamic balance.

NOTICE

For vehicles equipped with aluminum wheels:

Improper wheel weights can damage your vehicle's wheels. Use only Honda wheel weights for balancing.

Tire Rotation

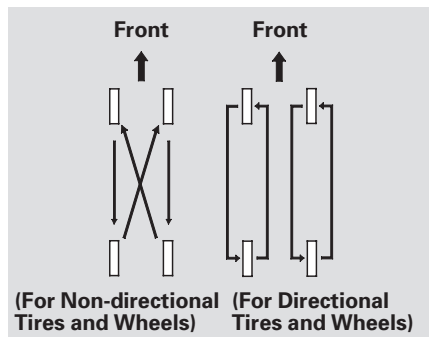

To help increase tire life and distribute wear more evenly, rotate the tires every 10,000 miles (16,000 km). Move the tires to the positions shown in the chart each time they are rotated. If you purchase directional tires, rotate only front-to-back.

Replacing Tires and Wheels

Replace your tires with radial tires of the same size, load range, speed rating, and maximum cold tire pressure rating (as shown on the tire's sidewall).

Mixing radial and bias-ply tires on your vehicle can reduce braking ability, traction, and steering accuracy. Using tires of a different size or construction can cause the ABS and vehicle stability assist system (VSA) to work inconsistently.

It is best to replace all four tires at the same time. If that is not possible or necessary, replace the two front tires or two rear tires as a pair. Replacing just one tire can seriously affect your vehicle's handling.

If you ever replace a wheel, make sure the new one matches the specifications of the original.

Replacement wheels are available at your dealer.

⚠ WARNING

Installing improper tires on your vehicle can affect handling and stability. This can cause a crash in which you can be seriously hurt or killed.

Always use the size and type of tires recommended in this owner's manual.

Wheel and Tire Specifications

Wheels:
16 x 6 1/2JJ

Tires:
215/65R16 98T

See page [248](#) for information about DOT Tire Quality Grading, and page [250](#) for tire size and labeling information.

Winter Driving

Tires marked “M + S” or “All Season” on the sidewall have an all-weather tread design suitable for most winter driving conditions.

For the best performance in snowy or icy conditions, you should install snow tires or tire chains. They may be required by local laws under certain conditions.

Snow Tires

If you mount snow tires on your vehicle, make sure they are radial tires of the same size and load range as original tires. Mount snow tires on all four wheels. The traction provided by snow tires on dry roads may be lower than your original tires. Check with the tire dealer for maximum speed recommendations.

CONTINUED

Tires

Tire Chains

Because your vehicle has limited tire clearance, mount only SAE Class “S” cable-type traction devices, with rubber chain tensioners, on the front tires. Use traction devices only when required by driving conditions or local laws. Make sure they are the correct size for your tires. Metal link-type “chains” should not be used.

When installing cables, follow the manufacturer’s instructions, and mount them as tight as you can. Make sure they are not contacting the brake lines or suspension. Drive slowly with them installed. If you hear them coming into contact with the body or chassis, stop and investigate. Remove them as soon as you begin driving on cleared roads.

NOTICE

Traction devices that are the wrong size or improperly installed can damage your vehicle’s brake lines, suspension, body, and wheels. Stop driving if they are hitting any part of the vehicle.

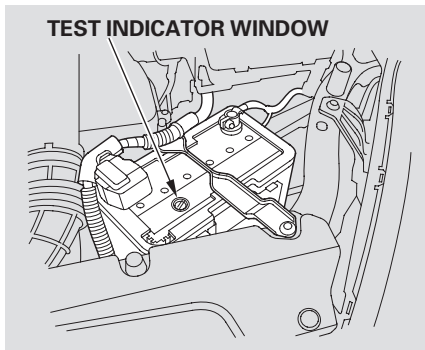

Check the condition of the battery monthly by looking at the test indicator window. The label on the battery explains the test indicator's colors.

Check the terminals for corrosion (a white or yellowish powder). To remove it, cover the terminals with a solution of baking soda and water. It will bubble up and turn brown. When this stops, wash it off with plain water. Dry off the battery with a

cloth or paper towel. Coat the terminals with grease to help prevent future corrosion.

If additional battery maintenance is needed, see your dealer or a qualified technician.

WARNING: Battery posts, terminals, and related accessories contain lead and lead compounds. **Wash your hands after handling.**

If you need to connect the battery to a charger, disconnect both cables to prevent damaging your vehicle's electrical system. Always disconnect the negative (–) cable first, and reconnect it last.

⚠ WARNING

The battery gives off explosive hydrogen gas during normal operation.

A spark or flame can cause the battery to explode with enough force to kill or seriously hurt you.

Wear protective clothing and a face shield, or have a skilled mechanic do the battery maintenance.

If your vehicle's battery is disconnected, or goes dead, the time setting will be reset to 1:00. To set the time again, follow the setting procedure (see page [137](#)).

Vehicle Storage

If you need to park your vehicle for an extended period (more than 1 month), there are several things you should do to prepare it for storage. Proper preparation helps prevent deterioration and makes it easier to get your vehicle back on the road. If possible, store your vehicle indoors.

- Fill the fuel tank.
- Change the engine oil and filter.
- Wash and dry the exterior completely.
- Clean the interior. Make sure the carpeting, floor mats, etc., are completely dry.
- Leave the parking brake off. Put the transmission in reverse (manual) or Park (automatic).

- Block the rear wheels.
- If the vehicle is to be stored for a longer period, it should be supported on jackstands so the tires are off the ground.
- Leave one window open slightly (if the vehicle is being stored indoors).
- Disconnect the battery.
- Support the front and rear wiper blade arms with a folded towel or rag so they do not touch the windshield.
- To minimize sticking, apply a silicone spray lubricant to all door and tailgate seals. Also, apply a vehicle body wax to the painted surfaces that mate with the door and tailgate seals.

- Cover the vehicle with a “breathable” cover, one made from a porous material such as cotton. Non-porous materials, such as plastic sheeting, trap moisture, which can damage the paint.
- If possible, periodically run the engine until it reaches full operating temperature (the cooling fans cycle on and off twice). Preferably, do this once a month.

If you store your vehicle for 1 year or longer, have your dealer perform the inspections called for in the 2 years/30,000 miles (48,000 km) maintenance schedule (Normal Conditions) as soon as you take it out of storage (see page 187). The replacements called for in the maintenance schedule are not needed unless the vehicle has actually reached that time or mileage.

This section covers the more common problems that motorists experience with their vehicles. It gives you information about how to safely evaluate the problem and what to do to correct it. If the problem has stranded you on the side of the road, you may be able to get going again. If not, you will also find instructions on getting your vehicle towed.

Changing a Flat Tire	220
If the Engine Won't Start.....	227
Jump Starting	229
If the Engine Overheats	231
Low Oil Pressure Indicator	233
Charging System Indicator.....	233
Malfunction Indicator Lamp	234
Brake System Indicator	235
Closing the Moonroof	236
Fuses	237
Fuse Locations.....	240
Emergency Towing	242

Changing a Flat Tire

If you have a flat tire while driving, stop in a safe place to change it. Drive slowly along the shoulder until you get to an exit or an area that is far away from the traffic lanes.

⚠ WARNING

The vehicle can easily roll off the jack, seriously injuring anyone underneath.

Follow the directions for changing a tire exactly, and never get under the vehicle when it is supported only by the jack.

1. Park the vehicle on firm, level, and non-slippery ground. Put the transmission in Park (automatic) or reverse (manual). Apply the parking brake. If you are towing a trailer, unhitch the trailer.
2. Turn on the hazard warning lights, and turn the ignition switch to the LOCK (0) position. Have all passengers get out of the vehicle while you change the tire.

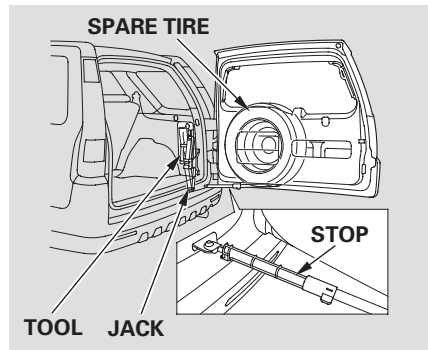

3. To keep the tailgate door open, use the stop from the tool kit. Put the stop on the support strut as shown.

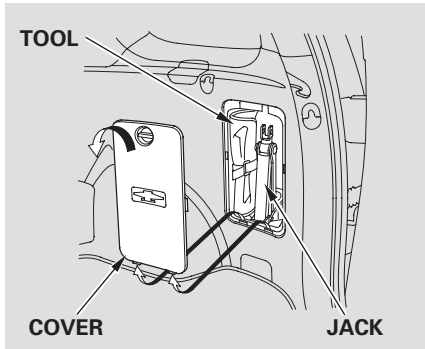

4. The tools and jack are behind a cover in the cargo area on the passenger's side. Remove the cover by turning the handle counterclockwise, then pulling out the cover.

5. Turn the jack's end bracket counterclockwise to loosen it, then remove the jack and tools.
6. Remove the spare tire cover. Do not forcibly pull off the cover or you may damage it.

Soft vinyl spare tire cover *If equipped*

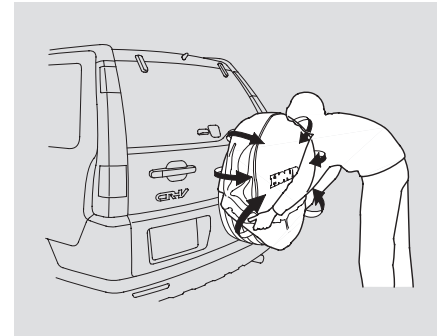

7. Zip the cover open.
8. Pull out the cover's two lower flaps. Pull the upper flaps out by gradually working your hands up the sides of the cover. Remove the cover.

CONTINUED

Changing a Flat Tire

Hard plastic spare tire cover *If equipped*

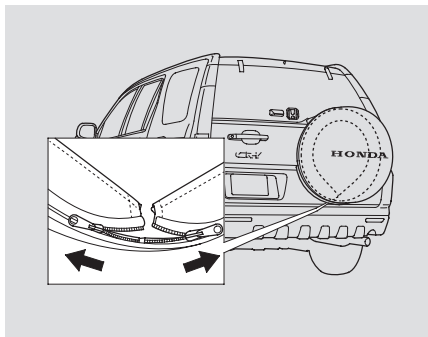

7. Unzip the flap around the lower edge of the cover.
8. Pull out the bottom of the cover, then gradually pull it off.

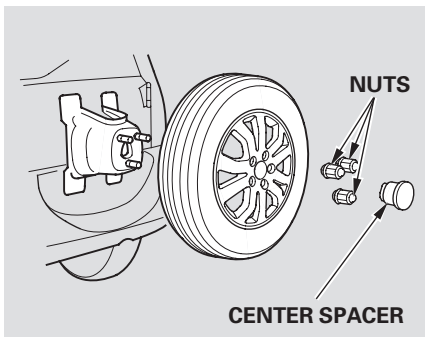

9. Pull off the center spacer. Using the wheel wrench, loosen the three wheel nuts and remove them. Remove the spare tire from the holder.
10. Loosen each wheel nut 1/2 turn with the wheel nut wrench.

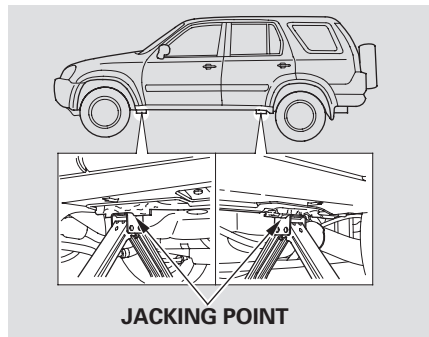

11. Place the jack under the jacking point nearest the tire you need to change. It is pointed to by an arrow molded into the underside of the body. Turn the end bracket clockwise until the top of the jack contacts the jacking point. Make sure the center of the jacking point tab is resting in the jack notch.



12. Use the extension and the wheel nut wrench as shown to raise the vehicle until the flat tire is off the ground.

13. Remove the wheel nuts, then remove the flat tire. Handle the wheel nuts carefully; they may be hot from driving. Place the flat tire on the ground with the outside surface facing up.

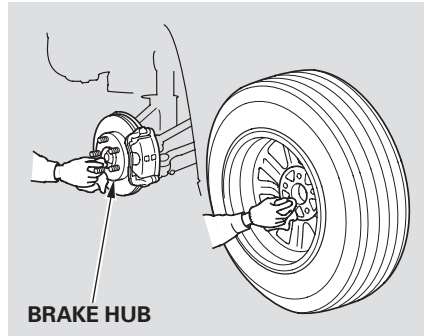

14. Before mounting the spare tire, wipe any dirt off the mounting surface of the wheel and hub with a clean cloth. Wipe the hub carefully; it may be hot from driving.

15. Put on the spare tire. Put the wheel nuts back on finger-tight, then tighten them in a crisscross pattern with the wheel nut wrench until the wheel is firmly against the hub. Do not try to tighten them fully.

16. Lower the vehicle to the ground, and remove the jack.

CONTINUED

Changing a Flat Tire

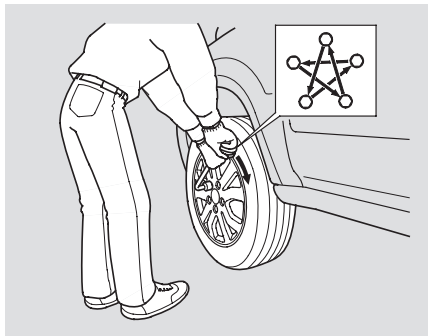

17. Tighten the wheel nuts securely in the same crisscross pattern. Have the wheel nut torque checked at the nearest automotive service facility.

Tighten the wheel nuts to:
80 lbf·ft (108 N·m , 11 kgf·m)

18. Remove the center cap from the flat tire.

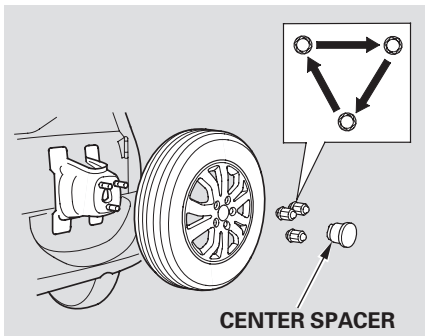

19. Put the flat tire on the spare tire holder. Put the wheel nuts on finger-tight, then tighten them with the wheel nut wrench. Put the center spacer in the center of the wheel.

Tighten the wheel nuts to:
40 lbf·ft (54 N·m , 5.5 kgf·m)

20. Store the jack in its holder. Turn the jack's end bracket to lock it in place. Store the tools, and install the cover on the side of the cargo area.

⚠ WARNING

Loose items can fly around the interior in a crash and could seriously injure the occupants.

Store the wheel, jack, and tools securely before driving.

21. Close the tailgate.

22. Install the spare tire cover.

Soft vinyl spare tire cover If equipped



23. Hold the cover at the 10 o'clock and 2 o'clock positions, then place the top of it over the spare tire.

NOTICE

Make sure the cover is at room temperature before you install it. If it's too cold, it won't fit easily over the tire.

24. Step back to check the alignment of the logo. If needed, pivot the cover until the logo is straight.



25. Starting at the top of the tire, position the outside seam of the cover slightly over the outside edge of the tire. Pull the cover on, a little at a time, and alternate side to side along the tire until you reach the bottom.

CONTINUED

Changing a Flat Tire

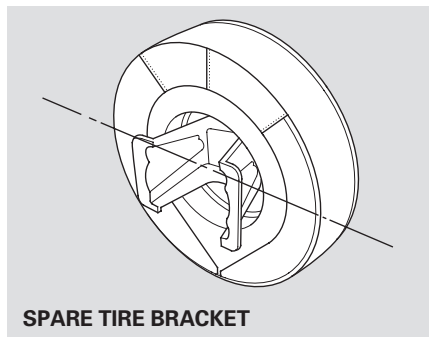

26. Pull the bottom of the cover over the tire.
27. If needed, readjust the cover to smooth out any wrinkles.
28. Zip the cover closed.

Hard plastic spare tire cover If equipped

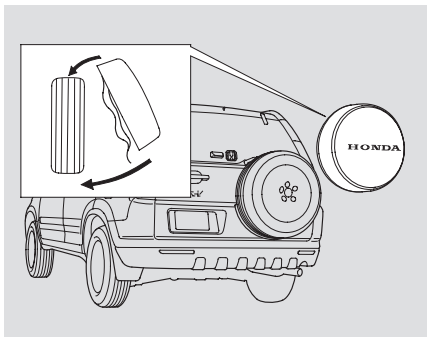

29. Place the top of the cover over the spare tire, then gradually push the bottom of the cover over the bottom of the tire.
30. Make sure the cover is horizontal. If needed, pivot the cover until the cover is horizontal.

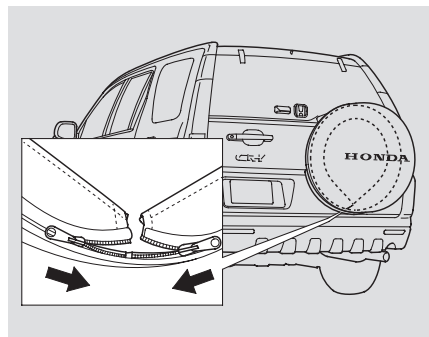

31. Zip the cover closed.

Diagnosing why the engine won't start falls into two areas, depending on what you hear when you turn the ignition switch to the START (III) position:

- You hear nothing, or almost nothing. The engine's starter motor does not operate at all, or operates very slowly.
- You can hear the starter motor operating normally, or the starter motor sounds like it is spinning faster than normal, but the engine does not start up and run.

Nothing Happens or the Starter Motor Operates Very Slowly

When you turn the ignition switch to the START (III) position, you do not hear the normal noise of the engine trying to start. You may hear a clicking sound or series of clicks, or nothing at all.

Check these things:

- Check the transmission interlock. If you have a manual transmission, the clutch pedal must be pushed all the way to the floor or the starter will not operate. With an automatic transmission, it must be in Park or neutral.
- Turn the ignition switch to the ON (II) position. Turn on the headlights, and check their brightness. If the headlights are very dim or do not come on at all, the battery is discharged. See **Jump Starting** on page [229](#).

- Turn the ignition switch to the START (III) position. If the headlights do not dim, check the condition of the fuses. If the fuses are OK, there is probably something wrong with the electrical circuit for the ignition switch or starter motor. You will need a qualified technician to determine the problem (see **Emergency Towing** on page [242](#)).

If the headlights dim noticeably or go out when you try to start the engine, either the battery is discharged or the connections are corroded. Check the condition of the battery and terminal connections (see page [217](#)). You can then try jump starting the vehicle from a booster battery (see page [229](#)).

If the Engine Won't Start

The Starter Operates Normally

In this case, the starter motor's speed sounds normal, or even faster than normal, when you turn the ignition switch to the START (III) position, but the engine does not run.

- Are you using a properly coded key? An improperly coded key will cause the immobilizer system indicator in the instrument panel to blink rapidly (see page [71](#)).
- Are you using the proper starting procedure? Refer to **Starting the Engine** on page [158](#) .

- Do you have fuel? Check the fuel gauge; the low fuel indicator may not be working.
- There may be an electrical problem, such as no power to the fuel pump. Check all the fuses (see page [237](#)).

If you find nothing wrong, you will need a qualified technician to find the problem. See **Emergency Towing** on page [242](#) .

Although this seems like a simple procedure, you should take several precautions.

⚠ WARNING

A battery can explode if you do not follow the correct procedure, seriously injuring anyone nearby.

Keep all sparks, open flames, and smoking materials away from the battery.

You cannot start your vehicle with an automatic transmission by pushing or pulling it.

To Jump Start Your Vehicle:

1. Open the hood, and check the physical condition of the battery. In very cold weather, check the condition of the electrolyte. If it seems slushy or frozen, do not try jump starting until it thaws.

NOTICE

If a battery sits in extreme cold, the electrolyte inside can freeze. Attempting to jump start with a frozen battery can cause it to rupture.

2. Turn off all the electrical accessories: heater, A/C, stereo system, lights, etc. Put the transmission in neutral (manual) or Park (automatic), and set the parking brake.

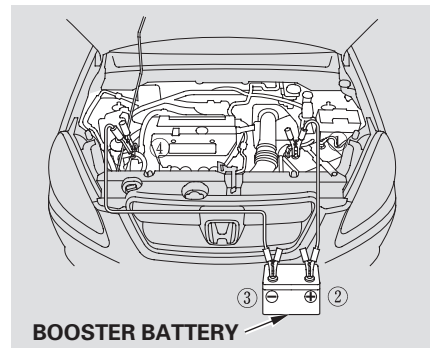

The numbers in the illustration show you the order to connect the jumper cables.

3. Connect one jumper cable to the positive (+) terminal on your battery. Connect the other end to the positive (+) terminal on the booster battery.

CONTINUED

Jump Starting

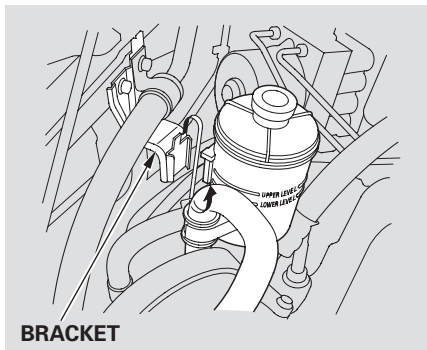

4. Remove the power steering reservoir from the bracket. Pull it away from the grounding strap.

Make sure the power steering hose is not touching the power steering belt or the pulley.

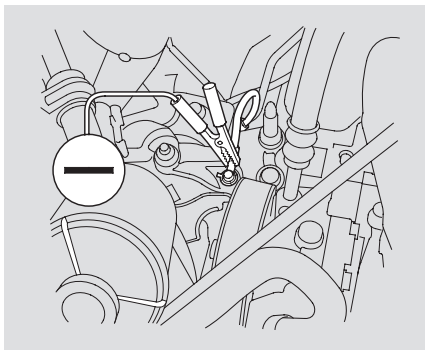

5. Connect the second jumper cable to the negative (–) terminal on the booster battery. Connect the other end to the grounding strap as shown. Do not connect this jumper cable to any other part of the engine.

6. If the booster battery is in another vehicle, have an assistant start that vehicle and run it at a fast idle.

7. Start your vehicle. If the starter motor still operates slowly, check that the jumper cables have good metal-to-metal contact.

8. Once your vehicle is running, disconnect the negative cable from your vehicle, then from the booster battery. Disconnect the positive cable from your vehicle, then from the booster battery.

9. Reinstall the power steering reservoir.

Keep the ends of the jumper cables away from each other and any metal on the vehicle until everything is disconnected. Otherwise, you may cause an electrical short.

The pointer of the vehicle's temperature gauge should stay in the midrange. If it climbs to the red mark, you should determine the reason (hot day, driving up a steep hill, etc.).

If the vehicle overheats, you should take immediate action. The only indication may be the temperature gauge climbing to or above the red mark. Or you may see steam or spray coming from under the hood.

NOTICE

Driving with the temperature gauge pointer at the red mark can cause serious damage to the engine.

WARNING

Steam and spray from an overheated engine can seriously scald you.

Do not open the hood if steam is coming out.

1. Safely pull to the side of the road. Put the transmission in neutral (manual) or Park (automatic), and set the parking brake. Turn off all the accessories, and turn on the hazard indicators.
2. If you see steam and/or spray coming from under the hood, turn off the engine. Wait until you see no more signs of steam or spray, then open the hood.
3. If you do not see steam or spray, leave the engine running, and watch the temperature gauge. If the high heat is due to overloading, the engine should start to cool down almost immediately. If it does, wait until the temperature gauge comes down to the midpoint, then continue driving.
4. If the temperature gauge stays at the red mark, turn off the engine.

CONTINUED

If the Engine Overheats

5. Look for any obvious coolant leaks, such as a split radiator hose. Everything is still extremely hot, so use caution. If you find a leak, it must be repaired before you continue driving (see **Emergency Towing** on page 242).
6. If you don't find an obvious leak, check the coolant level in the radiator reserve tank (see page 146).
7. If there was no coolant in the reserve tank, you may need to add coolant to the radiator. Let the engine cool down until the pointer reaches the middle of the temperature gauge or lower before checking the radiator.

WARNING

Removing the radiator cap while the engine is hot can cause the coolant to spray out, seriously scalding you.

Always let the engine and radiator cool down before removing the radiator cap.

8. Using gloves or a large heavy cloth, turn the radiator cap counterclockwise, without pushing down, to the first stop. After the pressure releases, push down on the cap, and turn it until it comes off.

9. Start the engine, and set the temperature control dial to maximum heat. Add coolant to the radiator up to the base of the filler neck. If you do not have the proper coolant mixture available, you can add plain water. Remember to have the cooling system drained and refilled with the proper mixture as soon as you can.
10. Put the radiator cap back on tightly. Run the engine, and watch the temperature gauge. If it goes back to the red mark, the engine needs repair (see **Emergency Towing** on page 242).
11. If the temperature stays normal, check the coolant level in the radiator reserve tank. If it has gone down, add coolant to the MAX mark. Put the cap back on tightly.

Low Oil Pressure Indicator



This indicator should never come on when the engine is running. If it starts flashing or stays on, the oil pressure has dropped very low or lost pressure. Serious engine damage is possible, and you should take immediate action.

NOTICE

Running the engine with low oil pressure can cause serious mechanical damage almost immediately. Turn off the engine as soon as you can safely get the vehicle stopped.

1. Safely pull off the road, and shut off the engine. Turn on the hazard warning lights.
2. Let the vehicle sit for a minute. Open the hood, and check the oil level (see page 145). An engine very low on oil can lose pressure during cornering and other driving maneuvers.
3. If necessary, add oil to bring the level back to the full mark on the dipstick (see page 193).
4. Start the engine, and watch the oil pressure indicator. If it does not go out within 10 seconds, turn off the engine. There is a mechanical problem that needs to be repaired before you can continue driving (see **Emergency Towing** on page 242).

Charging System Indicator



If the charging system indicator comes on brightly when the engine is running, the battery is not being charged.

Immediately turn off all electrical accessories. Try not to use other electrically operated controls such as the power windows. Keep the engine running; starting the engine will discharge the battery rapidly.

Go to a service station or garage where you can get technical assistance.

Malfunction Indicator Lamp



If the indicator comes on while driving, it means one of the engine's emissions control systems may have a problem. Even though you may feel no difference in your vehicle's performance, it can reduce your fuel economy and cause increased emissions. Continued operation may cause serious damage.

If you have recently refueled your vehicle, the indicator could come on because of a loose or missing fuel fill cap. You will also see a "CHECK FUEL CAP" message on the odometer display. Tighten the cap until it clicks at least once. Tightening the cap will not turn the indicator turn off immediately; it takes at least three days of normal driving.

If the indicator comes on repeatedly, even though it may turn off as you continue driving, have the vehicle checked by the dealer as soon as possible.

NOTICE

If you keep driving with the malfunction indicator lamp on, you can damage your vehicle's emissions controls and engine. Those repairs may not be covered by your vehicle's warranties.

This indicator may also come on along with the "D" indicator.

Readiness Codes

Your vehicle has certain "readiness codes" that are part of the on-board diagnostics for the emissions systems. In some states, part of the emissions testing is to make sure these codes are set. If they are not set, the test cannot be completed.

If the battery in your vehicle has been disconnected or gone dead, these codes are erased. It takes at least three days of driving under various conditions to set the codes again.

To check if they are set, turn the ignition to the ON (II) position, without starting the engine. The malfunction indicator lamp will come on for 20 seconds. If it then goes off, the readiness codes are set. If it blinks five times, the readiness codes are not set. If possible, do not take your vehicle for a state emissions test until the readiness codes are set. Refer to **State Emissions Testing** for more information (see page [254](#)).

U.S. Canada

BRAKE



The brake system indicator normally comes on when you turn the ignition switch to the ON (II) position, and as a reminder to check the parking brake. It will stay on if you do not fully release the parking brake.

If the brake system indicator comes on while driving, the brake fluid level is probably low. Press lightly on the brake pedal to see if it feels normal. If it does, check the brake fluid level the next time you stop at a service station (see page [201](#)).

If the fluid level is low, take your vehicle to a dealer, and have the brake system inspected for leaks or worn brake pads.

However, if the brake pedal does not feel normal, you should take immediate action. A problem in one part of the system's dual circuit design will still give you braking at two wheels. You will feel the brake pedal go down much farther before the vehicle begins to slow down, and you will have to press harder on the pedal.

Slow down by shifting to a lower gear, and pull to the side of the road when it is safe. Because of the long distance needed to stop, it is hazardous to drive the vehicle. You should have it towed and repaired as soon as possible (see **Emergency Towing** on page [242](#)).

If you must drive the vehicle a short distance in this condition, drive slowly and carefully.

If the ABS indicator and the VSA system indicator come on with the brake system indicator, have your vehicle inspected by your dealer immediately.

Closing the Moonroof

If equipped

If the electric motor will not close the moonroof, do the following:

1. Check the fuse for the moonroof motor (see page 237). If the fuse is blown, replace it with one of the same or lower rating.
2. Try closing the moonroof. If the new fuse blows immediately or the moonroof motor still does not operate, you can close the moonroof manually.
3. Get the moonroof wrench out of the tool kit in the cargo area.

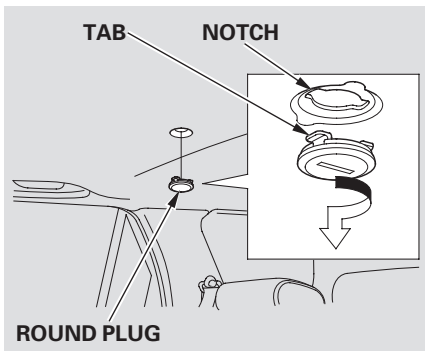

4. To remove the round plug in the center of the headliner, turn the plug by using a screwdriver or coin, then pry it out. Make sure to align the tabs on the round plug to the notches on the ceiling as shown in the illustration.

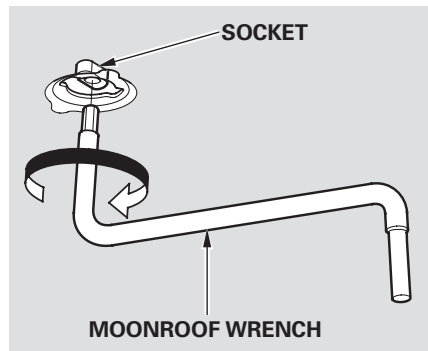

5. Insert the moonroof wrench into the socket behind this plug. Turn the wrench until the moonroof is fully closed.
6. Remove the wrench. Reinstall the round plug.

If you need to close the moonroof manually, it means the moonroof opening/closing function is developing a problem. Have your vehicle checked by your dealer.

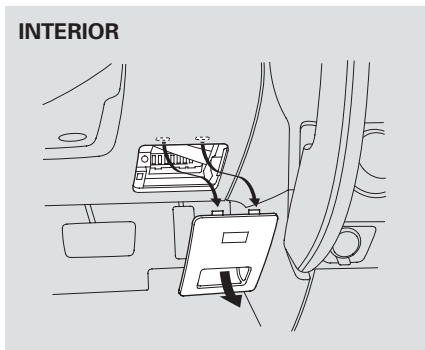

The vehicle's fuses are contained in three fuse boxes.

The interior fuse box is underneath the steering column. To remove the fuse box lid, pull it toward you and take the lid out of its hinges.

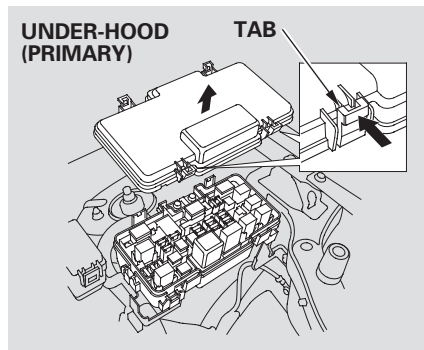

The primary under-hood fuse box is in the engine compartment on the driver's side. To open it, push the tabs as shown.

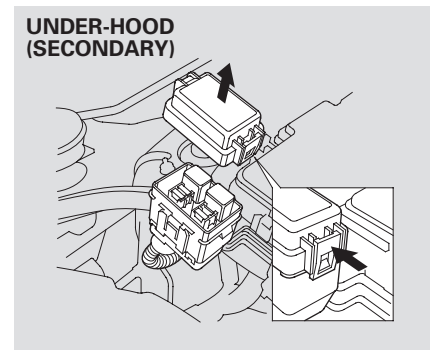

The secondary fuse box is next to the primary fuse box.

Fuses

Checking and Replacing Fuses

If something electrical in your vehicle stops working, check for a blown fuse first. Determine from the chart on pages 240 and 241, or the diagram on the fuse box lid, which fuse or fuses control that device. Check those fuses first, but check all the fuses before deciding that a blown fuse is the cause. Replace any blown fuses, and check if the device works.

1. Turn the ignition switch to the LOCK (0) position. Make sure the headlights and all other accessories are off.
2. Remove the cover from the fuse box.

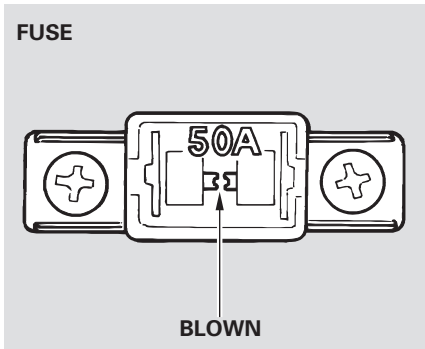

3. Check each of the large fuses in the primary under-hood fuse box by looking through the top at the wire inside. Removing these fuses requires a Phillips-head screwdriver.

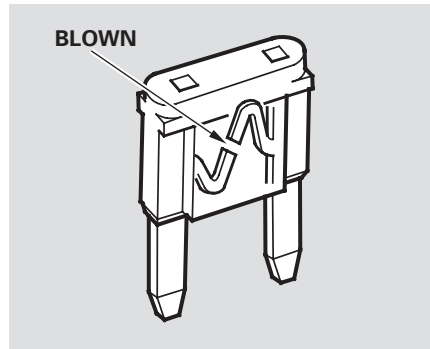

4. Check the smaller fuses in the under-hood fuse boxes and all the fuses in the interior fuse box by pulling out each one with the fuse puller provided in the primary under-hood fuse box.
5. Look for a blown wire inside the fuse. If it is blown, replace it with one of the spare fuses of the same rating or lower.

If you cannot drive the vehicle without fixing the problem, and you do not have a spare fuse, take a fuse of the same rating or a lower rating from one of the other circuits. Make sure you can do without that circuit temporarily (such as the accessory power socket or radio).

If you replace the blown fuse with a spare fuse that has a lower rating, it might blow out again. This does not indicate anything wrong. Replace the fuse with one of the correct rating as soon as you can.

NOTICE

Replacing a fuse with one that has a higher rating greatly increases the chances of damaging the electrical system. If you do not have a replacement fuse with the proper rating for the circuit, install one with a lower rating.

6. If the replacement fuse of the same rating blows in a short time, there is probably a serious electrical problem in your vehicle. Leave the blown fuse in that circuit and have your vehicle checked by a qualified mechanic.

If the radio fuse is removed, the audio system will disable itself. The next time you turn on the radio you will see “COdE” in the frequency display. Use the preset buttons to enter the five-digit code (see page 136).

If the driver’s power window fuse is removed, the AUTO function of the driver’s window will be disabled. To reset the AUTO function, see page 87 .

Fuse Locations

INTERIOR FUSE BOX

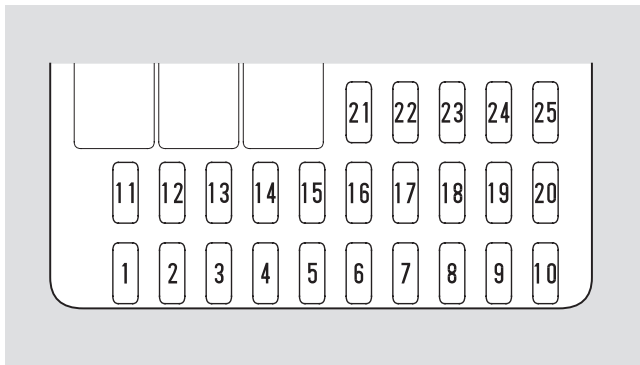

No.	Amps.	Circuits Protected
1	15 A	Ignition Coil
2	10 A	Rear Accessory Power Socket
3	10 A	Daytime running lights*
4	10 A	ACG
5	—	Not Used

No.	Amps.	Circuits Protected
6	7.5 A	Power Window Relay
7	20 A	Moonroof
8	7.5 A	Accessory, Radio
9	7.5 A	Rear Wiper
10	7.5 A	Meter
11	—	Not Used
12	7.5 A	Daytime running lights*
13	10 A	SRS
14	10 A	Remote Control Mirrors
15	15 A	+B FR ACC
16	20 A	Heated Seat
17	15 A	Fuel Pump
18	15 A	Front Accessory Power Socket
19	7.5 A	Turn Signal Lights
20	20 A	Front Wiper
21	—	Not Used
22	20 A	Front Right Power Window
23	20 A	Front Left Power Window
24	20 A	Rear Left Power Window
25	20 A	Rear Right Power Window

* : Canadian models

UNDER-HOOD FUSE BOXES

PRIMARY

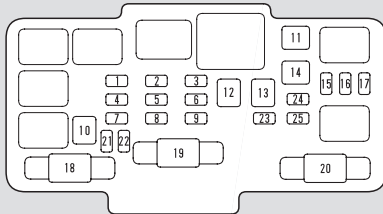

SECONDARY

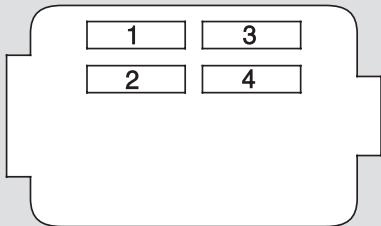

Primary Fuse Box

No.	Amps.	Circuits Protected
1	20 A	Condenser Fan
2	30 A	Engine
3	15 A	Interior Light
4	20 A	Cooling Fan
5	15 A	Hazard
6	15 A	Small Light
7	15 A	Horn, Stop
8	15 A	DBW
9	10 A	Back Up
10	30 A	ABS Motor
11	20 A	Rear Defroster
12	40 A	Heater Motor
13	40 A	Power Window

Secondary Fuse Box

No.	Amps.	Circuits Protected
1	20 A	LAF Heater
2	7.5 A	Daytime running lights*
3	15 A	FI ECU (ECM/PCM)
4	15 A	IG Coil

* : On Canadian models

No.	Amps.	Circuits Protected
14	40 A	Option
15	20 A	Left Headlight
16	20 A	Door Lock
17	20 A	Right Headlight
18	30 A	ABS F/S
19	100 A	Battery
20	50 A	Ignition 1
21-25	7.5A-30A	Spare Fuses

Emergency Towing

If your vehicle needs to be towed, call a professional towing service or organization. Never tow your vehicle with just a rope or chain. It is very dangerous.

The only way you can safely tow your vehicle is with flat-bed equipment. The operator will load your vehicle on the back of a truck. Any other method of towing will damage the drive system. When you contact the towing agency, inform them a flat-bed is required.

On 4WD models

NOTICE

Towing with only two tires on the ground will damage parts of the 4WD system. It should be transported on a flat-bed truck or trailer.

Refer to **Towing Your Vehicle Behind a Motorhome** on page [177](#) for non-emergency towing information.

The diagrams in this section give you the dimensions and capacities of your vehicle, and the locations of the identification numbers. It also includes information you should know about your vehicle's tires and emissions control systems.

Identification Numbers.....	244	Emissions Controls.....	251
Specifications	246	The Clean Air Act.....	251
DOT Tire Quality Grading		Crankcase Emissions Control	
(U.S. Vehicles)	248	System.....	251
Uniform Tire Quality		Evaporative Emissions Control	
Grading	248	System.....	251
Treadwear	248	Onboard Refueling Vapor	
Traction.....	248	Recovery	251
Temperature	249	Exhaust Emissions Controls ...	252
Tire Labeling.....	250	PGM-FI System	252
		Ignition Timing Control	
		System.....	252
		Three Way Catalytic	
		Converter	252
		Replacement Parts.....	252
		Three Way Catalytic Converter...	253
		State Emissions Testing	254

Identification Numbers

Your vehicle has several identifying numbers located in various places.

The vehicle identification number (VIN) is the 17-digit number your Honda dealer uses to register your vehicle for warranty purposes. It is also necessary for licensing and insuring your vehicle. The easiest place to find the VIN is on a plate fastened to the top of the dashboard. You can see it by looking through the windshield on the driver's side. It is also on the certification label attached to the driver's doorjamb, and is stamped on the engine compartment bulkhead. The VIN is also provided in bar code on the certification label.

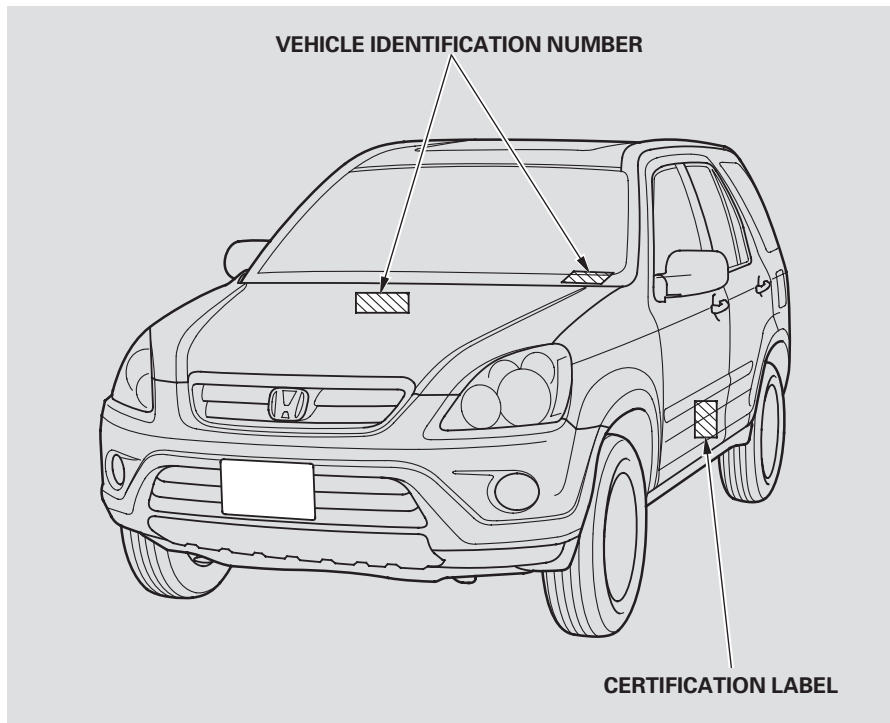

The engine number is stamped into the front of the engine block.

The transmission number is on a label on top of the transmission.

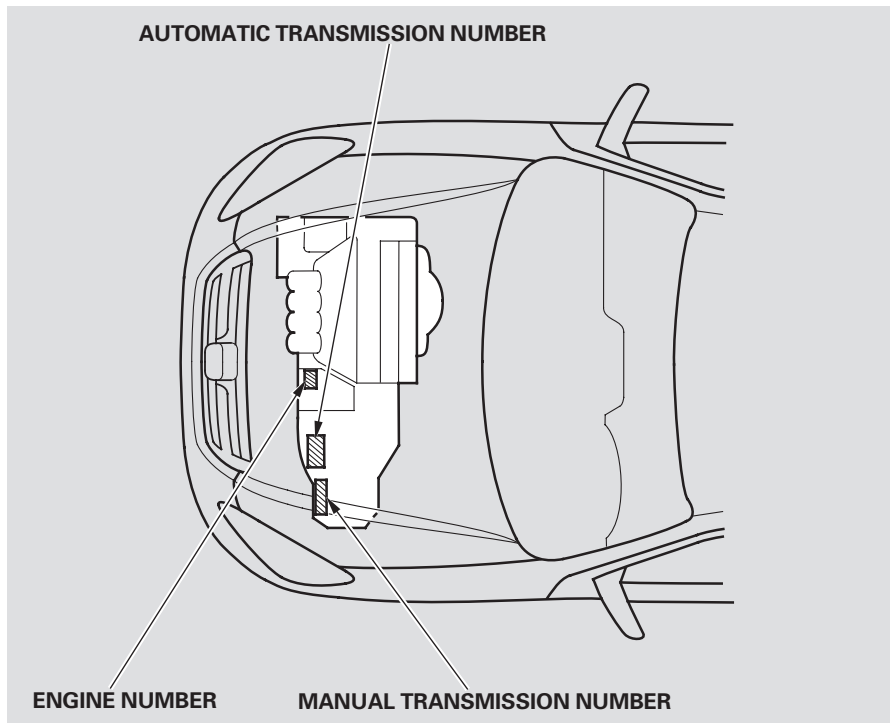

Specifications

Dimensions

Length		181.0 in (4,597 mm) 181.8 in (4,617 mm)* ¹
Width		70.2 in (1,782 mm)
Height		66.2 in (1,682 mm)
Wheelbase		103.1 in (2,620 mm)
Track	Front	60.4 in (1,533 mm)
	Rear	60.6 in (1,538 mm)

* 1 : U.S. SE model and Canada EX-L model

Weights

Gross vehicle weight rating	See the certification label attached to the driver's doorjamb.
-----------------------------	--

Engine

Type	Water cooled 4-stroke DOHC i-VTEC 4-cylinder gasoline engine
Bore x Stroke	3.43 x 3.90 in (87.0 x 99.0 mm)
Displacement	144 cu-in (2,354 cm ³)
Compression ratio	9.6 : 1
Spark plugs	IZFR6K-11 (NGK) SKJ20DR-M11 (DENSO)

Capacities

Fuel tank	Approx. 15.3 US gal (58 ℓ)
Engine oil	Change* ¹
	Including filter
	Without filter
	Total
	4.4 US qt (4.2 ℓ)
	4.2 US qt (4.0 ℓ)
	5.6 US qt (5.3 ℓ)

Capacities

Engine coolant	Automatic Transmission	
	Change* ²	1.43 US gal (5.4 ℓ)
	Total	1.88 US gal (7.1 ℓ)
	Manual Transmission	
	Change* ²	1.45 US gal (5.5 ℓ)
	Total	1.90 US gal (7.2 ℓ)
Automatic transmission fluid	Change	
	4WD	3.3 US qt (3.1 ℓ)
	2WD	3.1 US qt (2.9 ℓ)
	Total	
	4WD	7.6 US qt (7.2 ℓ)
	2WD	6.9 US qt (6.5 ℓ)
Manual transmission fluid	Change	2.0 US qt (1.9 ℓ)
	Total	2.4 US qt (2.3 ℓ)
Rear differential fluid (4WD)	Change	1.1 US qt (1.0 ℓ)
	Total	1.3 US qt (1.2 ℓ)
Windshield washer reservoir	U.S. Vehicles	2.6 US qt (2.5 ℓ)
	Canada Vehicles	4.8 US qt (4.5 ℓ)

* 1 : Excluding the oil remaining in the engine

* 2 : Including the coolant in the reserve tank and that remaining in the engine

Reserve tank capacity:
0.16 US gal (0.6 ℓ)

Air Conditioning

Refrigerant type	HFC-134a (R-134a)
Charge quantity	17.0– 18.7 oz (480– 530 g)
Lubricant type	SP-10

Lights

Headlights	High/Low	12 V – 55 W (H1)
Front turn signal lights		12 V – 21 W
Parking lights/side marker lights		12 V – 3 CP
Rear turn signal lights		12 V – 21 W (Amber)
Stop/Taillights		12 V – 21/5 W
Back-up lights		12 V – 21 W
License plate light		12 V – 5 W
Ceiling light		12 V – 8 W
Spotlights		12 V – 4 CP
Cargo area Light		12 V – 8 W
Rear side marker lights		12 V – 3 CP
High-mount brake light		12 V – 21 W

Battery

Capacity	12 V – 36 AH/5 HR
	12 V – 47 AH/20 HR

Fuses

Interior	See page 240 or the fuse label attached to the inside of the fuse box door under the steering column.
Under-hood	See page 241 or the fuse box cover.

Alignment

Toe-in	Front	0.0 in (0 mm)
	Rear	0.08 in (2.0 mm)
Camber	Front	0°
	Rear	–1°
Caster	Front	1°45'

Tires

Size	Front/Rear	215/65R16 98T
Pressure	Front	29 psi (200 kPa , 2.0 kgf/cm ²)
	Rear	29 psi (200 kPa , 2.0 kgf/cm ²)

DOT Tire Quality Grading (U.S. Vehicles)

The tires on your vehicle meet all U.S. Federal Safety Requirements. All tires are also graded for treadwear, traction, and temperature performance according to Department of Transportation (DOT) standards. The following explains these gradings.

Uniform Tire Quality Grading

Quality grades can be found where applicable on the tire sidewall between the tread shoulder and the maximum section width. For example:

Treadwear 200

Traction AA

Temperature A

All passenger car tires must conform to Federal Safety Requirements in addition to these grades.

Treadwear

The treadwear grade is a comparative rating based on the wear rate of the tire when tested under controlled conditions on a specified government test course. For example, a tire graded 150 would wear one and one-half (1 1/2) times as well on the government course as a tire graded 100. The relative performance of tires depends upon the actual conditions of their use, however, and may depart significantly from the norm due to variations in driving habits, service practices, and differences in road characteristics and climate.

Traction — AA, A, B, C

The traction grades, from highest to lowest, are AA, A, B, and C. Those grades represent the tire's ability to stop on wet pavement as measured under controlled conditions on specified government test surfaces of asphalt and concrete. A tire marked C may have poor traction performance.

Warning: The traction grade assigned to this tire is based on straight-ahead braking traction tests, and does not include acceleration, cornering, hydroplaning, or peak traction characteristics.

Temperature – A, B, C

The temperature grades are A (the highest), B, and C, representing the tire's resistance to the generation of heat, and its ability to dissipate heat when tested under controlled conditions on a specified indoor laboratory test wheel. Sustained high temperature can cause the material of the tire to degenerate and reduce tire life, and excessive temperature can lead to sudden tire failure. Grade C corresponds to a level of performance that all passenger car tires must meet under the Federal Motor Vehicle Safety Standard No. 109. Grades B and A represent higher levels of performance on the laboratory test wheel than the minimum required by law.

Warning: The temperature grade for this tire is established for a tire that is properly inflated and not overloaded. Excessive speed, underinflation, or excessive loading, either separately or in combination, can cause heat buildup and possible tire failure.

Tire Labeling

The tires that came on your vehicle have a number of markings. Those you should be aware of are described below.

Tire Size

Whenever tires are replaced, they should be replaced with tires of the same size. Below is an example of tire size with an explanation of what each component means.

215/65R16 98T

215 — Tire width in millimeters.

65 — Aspect ratio (the tire's section height as a percentage of its width).

R — Tire construction code (R indicates radial).

16 — Rim diameter in inches.

98 — Load index (a numerical code associated with the maximum load the tire can carry).

T — Speed symbol (an alphabetical code indicating the maximum speed rating).

Tire Identification Number

The tire identification number (TIN) is a group of numbers and letters that look like this example:

DOT B97R FW6X 2202

DOT — This indicates that the tire meets all requirements of the U.S. Department of Transportation.

B97R — Manufacturer's identification mark.

FW6X — Tire type code.

2202 — Date of manufacture.

Maximum Tire Pressure

Max Press — The maximum air pressure the tire can hold.

Maximum Tire Load

Max Load — The maximum load the tire can carry at maximum air pressure.

The burning of gasoline in your vehicle's engine produces several by-products. Some of these are carbon monoxide (CO), oxides of nitrogen (NO_x), and hydrocarbons (HC). Gasoline evaporating from the tank also produces hydrocarbons. Controlling the production of NO_x, CO, and HC is important to the environment. Under certain conditions of sunlight and climate, NO_x and HC react to form photochemical "smog." Carbon monoxide does not contribute to smog creation, but it is a poisonous gas.

The Clean Air Act

The United States Clean Air Act* sets standards for automobile emissions. It also requires that automobile manufacturers explain to owners how their emissions controls work and what to do to maintain them. This section summarizes how the emissions controls work. Scheduled maintenance is on page 187.

* In Canada, Honda vehicles comply with the Canadian emission requirements, as specified in an agreement with Environment Canada, at the time they are manufactured.

Crankcase Emissions Control System

Your vehicle has a positive crankcase ventilation system. This keeps gasses that build up in the engine's crankcase from going into the atmosphere. The positive

crankcase ventilation valve routes them from the crankcase back to the intake manifold. They are then drawn into the engine and burned.

Evaporative Emissions Control System

As gasoline evaporates in the fuel tank, an evaporative emissions control canister filled with charcoal adsorbs the vapor. It is stored in this canister while the engine is off. After the engine is started and warmed up, the vapor is drawn into the engine and burned during driving.

Onboard Refueling Vapor Recovery

The onboard refueling vapor recovery (ORVR) system captures the fuel vapors during refueling. The vapors are adsorbed in a canister filled with activated carbon. While driving, the fuel vapors are drawn into the engine and burned off.

Emissions Controls

Exhaust Emissions Controls

The exhaust emissions controls include three systems: PGM-FI, ignition timing control, and three way catalytic converter. These three systems work together to control the engine's combustion and minimize the amount of HC, CO, and NOx that come out the tailpipe. The exhaust emissions control systems are separate from the crankcase and evaporative emissions control systems.

PGM-FI System

The PGM-FI system uses sequential multiport fuel injection. It has three subsystems: air intake, engine control, and fuel control. The powertrain control module (PCM) in automatic transmission vehicles or the engine control module (ECM) in manual transmission vehicles use various sensors to determine how much air is going into the engine. It then controls how much fuel to inject under all operating conditions.

Ignition Timing Control System

This system constantly adjusts the ignition timing, reducing the amount of HC, CO, and NOx produced.

Three Way Catalytic Converter

The three way catalytic converter is in the exhaust system. Through chemical reactions, it converts HC, CO, and NOx in the engine's exhaust to carbon dioxide (CO₂), nitrogen (N₂), and water vapor.

Replacement Parts

The emissions control systems are designed and certified to work together in reducing emissions to levels that comply with the Clean Air Act. To make sure the emissions remain low, you should use only new Honda replacement parts or their equivalent for repairs. Using lower quality parts may increase the emissions from your vehicle.

The emissions control systems are covered by warranties separate from the rest of your vehicle. Read your warranty manual for more information.

The three way catalytic converter contains precious metals that serve as catalysts, promoting chemical reactions to convert the exhaust gasses without affecting the metals. The catalytic converter is referred to as a three-way catalyst, since it acts on HC, CO, and NOx. A replacement unit must be an original Honda part or its equivalent.

The three way catalytic converter must operate at a high temperature for the chemical reactions to take place. It can set on fire any combustible materials that come near it. Park your vehicle away from high grass, dry leaves, or other flammables.

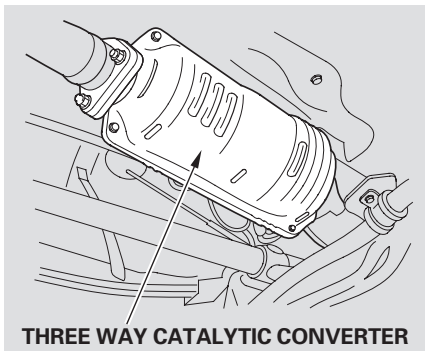

A defective three way catalytic converter contributes to air pollution, and can impair your engine's performance. Follow these guidelines to protect your vehicle's three way catalytic converter.

- Always use unleaded gasoline. Even a small amount of leaded gasoline can contaminate the catalyst metals, making the three way catalytic converter ineffective.

- Keep the engine tuned-up.
- Have your vehicle diagnosed and repaired if it is misfiring, back-firing, stalling, or otherwise not running properly.

State Emissions Testing

Testing of Readiness Codes

If you take your vehicle for a state emissions test shortly after the battery has been disconnected or gone dead, it may not pass the test. This is because of certain “readiness codes” that must be set in the on-board diagnostics for the emissions systems. These codes are erased when the battery is disconnected, and set again only after several days of driving under a variety of conditions.

If the testing facility determines that the readiness codes are not set, you will be requested to return at a later date to complete the test. If you must get the vehicle retested within the next two or three days, you can condition the vehicle for retesting by doing the following.

- Make sure the gas tank is nearly, but not completely full (around 3/4).

- Make sure the vehicle has been parked with the engine off for 8 hours or more.
- Make sure the ambient temperature is between 20° and 95° F.
- Without touching the accelerator pedal, start the engine, and let it idle for 20 seconds.
- Keep the vehicle in Park (automatic transmission) or neutral (manual transmission). Increase the engine speed to 2,000 rpm, and hold it there until the temperature gauge rises to at least 1/4 of the scale (about 3 minutes).
- Select a nearby lightly traveled major highway where you can maintain a speed of 50 to 60 mph (80 to 97 km/h) for at least 20 minutes. Drive on the highway in D (A/T) or 5th (M/T). Do not use

the cruise control. When traffic allows, drive for 90 seconds without moving the accelerator pedal. (Vehicle speed may vary slightly; this is okay.) If you cannot do this for a continuous 90 seconds because of traffic conditions, drive for at least 30 seconds, then repeat it two more times (for a total of 90 seconds).

- Then drive in city/suburban traffic for at least 10 minutes. When traffic conditions allow, let the vehicle coast for several seconds without using the accelerator pedal or the brake pedal.

If the testing facility determines the readiness codes are still not set, see your dealer.

Customer Service	
Information.....	256
Warranty Coverages	257
Reporting Safety Defects	
(U.S. Vehicles)	258
Authorized Manuals.....	259

Customer Service Information

Honda dealership personnel are trained professionals. They should be able to answer all your questions. If you encounter a problem that your dealership does not solve to your satisfaction, please discuss it with the dealership's management. The service manager or general manager can help. Almost all problems are solved in this way.

If you are dissatisfied with the decision made by the dealership's management, contact your Honda Customer Service Office.

U.S. Owners:

American Honda Motor Co., Inc.
Automobile Customer Service
Mail Stop 500-2N-7A
1919 Torrance Boulevard
Torrance, California 90501-2746

Tel: (800) 999-1009

Canadian Owners: **CUSTOMER RELATIONS RELATIONS AVEC LA CLIENTÈLE**

Honda Canada Inc.
715 Milner Avenue
Toronto, ON
M1B 2K8

Tel: 1-888-9-HONDA-9
Fax: Toll-free 1-877-939-0909
Toronto (416) 287-4776

In Puerto Rico and the U.S. Virgin Islands:

Bella International
P.O. Box 190816
San Juan, PR 00919-0816

Tel: (787) 620-7098

When you call or write, please give us this information:

- Vehicle Identification Number (see page [244](#))
- Name and address of the dealer who services your vehicle
- Date of purchase
- Mileage on your vehicle
- Your name, address, and telephone number
- A detailed description of the problem
- Name of the dealer who sold the vehicle to you

U.S. Owners

Your new vehicle is covered by these warranties:

New Vehicle Limited Warranty — covers your new vehicle, except for the battery, emissions control systems, and accessories against defects in materials and workmanship.

Emissions Control Systems Defects Warranty and Emissions Performance Warranty — these two warranties cover your vehicle's emissions control systems. Time, mileage, and coverage are conditional. Please read your warranty booklet for exact information.

Original Equipment Battery Limited Warranty — this warranty gives up to 100 percent credit toward a replacement battery.

Seat Belt Limited Warranty — a seat belt that fails to function properly is covered for the useful life of the vehicle.

Rust Perforation Limited Warranty — all exterior body panels are covered for rust-through from the inside for the specified time period with no mileage limit.

Accessory Limited Warranty — Honda accessories are covered under this warranty. Time and mileage limits depend on the type of accessory and other factors. Please read your warranty booklet for details.

Replacement Parts Limited Warranty — covers all Honda replacement parts against defects in materials and workmanship.

Replacement Battery Limited Warranty — provides prorated coverage for a replacement battery purchased from your dealer.

Replacement Muffler Lifetime Limited Warranty — provides coverage for as long as the purchaser of the muffler owns the vehicle.

Restrictions and exclusions apply to all these warranties. Please read the 2006 Honda Warranty Information booklet that came with your vehicle for precise information on warranty coverages. Your vehicle's original tires are covered by their manufacturer. Tire warranty information is in a separate booklet.

Canadian Owners

Please refer to the 2006 Warranty Manual that came with your vehicle.

Reporting Safety Defects (U.S. Vehicles)

If you believe that your vehicle has a defect which could cause a crash or could cause injury or death, you should immediately inform the National Highway Traffic Safety Administration (NHTSA) in addition to notifying American Honda Motor Co., Inc.

If NHTSA receives similar complaints, it may open an investigation, and if it finds that a safety defect exists in a group of vehicles, it may order a recall and remedy campaign. However, NHTSA cannot become involved in individual problems between you, your dealer, or American Honda Motor Co., Inc.

To contact NHTSA, you may call the Vehicle Safety Hotline toll-free at 1-800-327-4236 (TTY 1-800-424-9153); go to <http://www.safercar.gov>; or write to: Administrator, NHTSA, 400 Seventh Street, SW., Washington, DC 20590.

You can also obtain other information about motor vehicle safety from <http://www.safercar.gov>.

Purchasing Factory Authorized Manuals (U.S. only)

The publications shown below can be purchased from Helm Incorporated. You can order in any of three ways:

- Detach and mail the order form on the right half of this page
- Call Helm Inc. at 1-800-782-4356 (credit card orders only)
- Go online at www.helminc.com

If you are interested in other years or models, contact Helm Inc. at 1-800-782-4356.

Publication Form Number	Form Description	Price Each*
61S9A04	2006 Honda CR-V Service Manual	\$75.00
61S9A03EL	2006 Honda CR-V Electrical Troubleshooting Manual	\$50.00
61S9A30	2002-06 Honda CR-V Body Repair Manual	\$44.00
31S9A640	2006 Honda CR-V Owner's Manual	\$35.00
31S9AM10	2006 Honda CR-V Honda Service History	\$12.00
31S9AQ30	2006 Honda CR-V Quick Start Guide	\$12.00
HON-R	Order Form for Previous Years- Indicate Year and Model Desired	FREE

* Prices are subject to change without notice and without incurring obligation.

Valid only for sales within the United States. Canadian owners should contact their authorized Honda dealer.

ORDER TOLL FREE: 1-800-782-4356

(NOTE: For Credit Card Holder Orders Only)

Monday-Friday 8:00 A.M. — 6:00 P.M. EST

MINIMUM CREDIT CARD PURCHASE \$10.00

OR

By completing this form you can order the materials desired. You can pay by check or money order, or charge to your credit card. Mail to Helm Incorporated at the address shown on the back of the order form.

2006 HON	PUBLICATION NUMBER	VEHICLE MODEL		Qty	Price Each*	Total Price
		Name	Year			
* Prices are subject to change without notice and without incurring obligation.					TOTAL MATERIAL	
					Mich. Purchases Add 6% Sales Tax	
Orders are mailed within 10 days. Please allow adequate time for delivery.					HANDLING CHARGE	\$6.95
					GRAND TOTAL	

A

Accessories.....	148
ACCESSORY (Ignition Key Position)	72
Accessory Power Sockets.....	95
Additives, Engine Oil.....	193
Adjusting the Steering Wheel.....	69
Advanced Airbags.....	25
Airbag (SRS)	9, 21
Air Conditioning System.....	98
Usage	100
Air Pressure, Tires	213
Alcohol in Gasoline.....	142
Antifreeze	196
Anti-lock Brakes (ABS) Indicator.....	57, 168
Operation	168
Anti-theft, Audio System.....	136
Anti-theft Steering Column Lock ..	72
Audio System	103
Automatic Seat Belt Tensioners	19
Automatic Speed Control.....	138
Automatic Transmission.....	161
Capacity, Fluid	246
Checking Fluid Level.....	199

D3 Mode	163
Shifting.....	161
Shift Lever Position Indicators.....	161
Shift Lever Positions	162
Shift Lock Release.....	165

B

Battery Charging System Indicator.....	56, 233
Jump Starting	229
Maintenance.....	217
Specifications	247
Before Driving	141
Belts, Seat	8, 18
Beverage Holders	91
Booster Seats	47
Brakes Anti-lock System (ABS)	168
Break-in, New Linings	142
Bulb Replacement	205
Fluid	201
Parking.....	68
System Indicator.....	56, 235

System Design	167
Wear Indicators	167
Braking System.....	167
Break-in, New Vehicle	142
Brightness Control, Instruments...	67
Brights, Headlights	66, 67
Built-in Table	91
Bulb Replacement Back-up Lights	205
Brake Lights.....	205
Front Parking Lights.....	205
Front Side Marker Lights.....	205
Headlights	203
High-mount Brake Light	207
Rear Side Marker Lights	205
Specifications	247
Turn Signal Lights.....	205
Bulbs, Halogen.....	203

C

Capacities Chart.....	246
Carbon Monoxide Hazard	50
Cargo.....	150

CONTINUED

Index

Cargo, How to Carry 150
Cassette Player
 Care 115, 131
 Operation 113, 129
CAUTION, Explanation of ii
CD Care 134
CD Changer 111, 125
CD Changer Error
 Messages 112, 128
CD Error Messages 112
CD Player 109, 124
Center Pocket 95
Center Table 94
Certification Label 244
Chains, Tires 216
Changing a Flat Tire 220
Changing Oil 194
 How to 194
 When to 187
Charging System Indicator 56, 233
Check Fuel Cap Indicator 63
Checklist, Before Driving 157
Child Safety 32
 Booster Seats 47
 Child Seats 32, 39
 Important Safety Reminders 32

 Infants 37
 Large Children 46
 LATCH 41
 Risks with Airbags 33
 Small Children 38
 Tethers 45
 Warning Labels 34
 Where Should a Child Sit? 33
Child Seats 32, 39
 LATCH 41
 Tether Anchorage Points 45
Childproof Door Locks 73
Cleaning Seat Belts 208
Clock 137
Clutch Fluid 202
CO in the Exhaust 251
Coin Tray 93
Cold Weather, Starting in 158
Consumer Information * 256
Controls, Instruments and 53
Coolant
 Adding 196
 Checking 146
 Proper Solution 196
 Temperature Gauge 62

Crankcase Emissions Control
 System 251
Cruise Control Indicator 58
Cruise Control Operation 138
Cup Holders 91
Customer Service Office 256

D

DANGER, Explanation of ii
Dashboard 3, 54
Daytime Running Lights 67
Daytime Running Lights
 Indicator 59
Dead Battery 229
Defects, Reporting Safety 258
Defogger, Rear Window 68
Defrosting the Windows 101
Detachable Anchor 85
Dimensions 246
Dimming the Headlights 66, 67
Dipstick
 Automatic Transmission 199
 Engine Oil 145
Directional Signals 66
Disc Brake Wear Indicators 167

Disc Care 134
 Disc Changer 111, 125
 Care 134
 Operation 111, 125
 Disc Changer Error
 Message 112, 128
 Disc Player Error Message 112
 Disposal of Used Oil 195
 Doors
 Childproof Door Locks 73
 Locking and Unlocking 73
 Power Door Locks 73
 DOT Tire Quality Grading 248
 Downshifting, Manual
 Transmission 159
 Driver and Passenger Safety 5
 Driving 155
 Economy 147
 Driving Guidelines 156
 D3 Mode 163
 Dust and Pollen Filter 209

E

Economy, Fuel 147

Emergencies 219
 Battery, Jump Starting 229
 Brake System Indicator 235
 Changing a Flat Tire 220
 Charging System Indicator 233
 Checking the Fuses 237
 Hazard Warning Flashers 67
 Jump Starting 229
 Low Oil Pressure Indicator 233
 Malfunction Indicator Lamp 234
 Manually Closing Moonroof 236
 Overheated Engine 231
 Towing 242
 Emergency Brake 68
 Emergency Flashers 67
 Emergency Towing 242
 Emissions Controls 251
 Emissions Testing, State 254
 Engine
 Adding Engine Coolant 196
 Coolant Temperature Gauge 62
 If It Won't Start 227
 Malfunction Indicator
 Lamp 56, 234
 Oil Pressure Indicator 56, 233
 Oil, What Kind to Use 193

Overheating 231
 Specifications 246
 Speed Limiter 160, 164
 Starting 158
 Ethanol in Gasoline 142
 Evaporative Emissions Controls .. 251
 Exhaust Fumes 50
 Expectant Mothers, Use of Seat
 Belts by 16

F

Fan, Interior 99
 Features 97
 Filling the Fuel Tank 143
 Filters
 Dust and Pollen 209
 Oil 194
 Flashers, Hazard Warning 67
 Flat Tire, Changing a 220

CONTINUED

Index

Fluids

Automatic Transmission.....	199
Brake.....	201
Clutch.....	202
Manual Transmission	200
Power Steering.....	202
Windshield Washer.....	198
Folding Rear Seat	82, 83
Four-way Flashers	67
Front Airbags.....	9, 23
Front Seat	
Adjusting.....	78
Heaters.....	86
Airbags.....	9, 23
Fuel.....	142
Check Fuel Cap Indicator.....	63
Fill Door and Cap.....	143
Low Fuel Indicator	59
Gauge	62
Octane Requirement.....	142
Oxygenated	142
Tank, Refueling	143
Fuel Economy	147
Fuses, Checking the.....	237

G

Gas Mileage, Improving.....	147
Gasohol	142
Gasoline	142
Low Fuel Indicator	59
Gauge	62
Octane Requirement	142
Tank, Refueling	143
Gas Station Procedures.....	143
Gauges	
Engine Coolant Temperature	62
Fuel.....	62
Gearshift Lever Positions	
Automatic Transmission.....	161
Manual Transmission	159
Glove Box	93
Gross Vehicle Weight Rating (GVWR)	173, 246

H

Halogen Headlight Bulbs.....	203
Hatch Glass	74
Hazard Warning Flashers.....	67

Headlights

Aiming.....	203
Daytime Running Lights.....	67
High Beam Indicator	59
Reminder Tone	66
Replacing Halogen Bulbs	203
Turning on.....	66
Head Restraints	80
Heated Mirrors	89
Heater, Seat	86
Heating and Cooling.....	98
High Beam Lever.....	67
Hood, Opening the	144
Horn.....	4, 64
Hydraulic Clutch.....	202

I

Identification Number, Vehicle....	244
Ignition	
Keys.....	70
Switch.....	72
Timing Control System.....	252
Immobilizer System.....	71
Important Safety Precautions	6

- Indicators
- ABS (Anti-Lock Brake)..... 57, 168
 - Brake (Parking and Brake System) 56, 235
 - Charging System 56, 233
 - Check Fuel Cap..... 63
 - Cruise Control..... 58
 - DRL (Daytime Running Lights)..... 59
 - High Beam..... 59
 - Key (Immobilizer System) 57
 - Low Fuel 59
 - Low Oil Pressure 56, 233
 - Passenger Airbag Off..... 30
 - Side Airbag Off 57
 - SRS 57
 - Turn Signal and Hazard Warning 59
 - VSA (Vehicle Stability Assist) 58, 170
 - Washer Level 60
- Indicators, Instrument Panel..... 55
- Infant Restraint 37
- Infant Seats..... 37
- Tether Anchorage Point..... 45
- Inflation, Proper Tire 212
- Recommended Pressures..... 213
- Inside Mirror 88
- Inspection, Tire 213
- Installing a Child Seat 40
- Instrument Panel 55
- Instrument Panel Brightness 67
- Instruments and Controls..... 53
- Interior Lights 95
- Introduction i
- J**
- Jacking up the Vehicle 222
- Jack, Tire 220
- Jump Starting 229
- K**
- Keys..... 70
- L**
- Label, Certification 244
- Lane Change, Signaling 66
- Lap/Shoulder Belts 14, 18
- LATCH Anchorage System..... 41
- Lights
- Bulb Replacement 203
 - Indicator 55
 - Parking..... 66
 - Turn Signal..... 66
- Load Limits..... 151
- LOCK (Ignition Key Position) 72
- Locks
- Anti-theft Steering Column 72
 - Childproof Door 73
 - Fuel Fill Door 143
 - Glove Box 93
 - Power Door 73
 - Tailgate 74
- Low Coolant Level..... 146
- Low Fuel Indicator 59
- Low Oil Pressure Indicator ... 56, 233
- Lower Anchors..... 41
- Lubricant Specifications Chart 246
- Luggage, Storing (Cargo) 150
- Luggage Net (Cargo Net) 153

CONTINUED

Index

M

- Maintenance..... 183
 - Owner's Maintenance
 - Checks 186
 - Record..... 189-191
 - Required Indicator..... 60
 - Safety..... 184
 - Schedule 187-188
- Malfunction Indicator Lamp .. 56, 234
- Manual Transmission..... 159
 - Checking Fluid Level..... 200
 - Shifting..... 159
- Manual Transmission Fluid 200
- Meters, Gauges..... 55, 61
- Methanol in Gasoline 142
- Mirrors, Adjusting 88
- Modifying Your Vehicle..... 149
- Moonroof 88
 - Closing Manually 236
 - Operation 88

N

- Neutral Gear Position..... 163
- New Vehicle Break-in 142

- Normal Shift Speeds..... 160
- NOTICE, Explanation of..... i
- Numbers, Identification 244

O

- Octane Requirement, Gasoline ... 142
- Odometer..... 62
- Odometer, Trip..... 61
- Off-Highway Driving..... 179
- Oil
 - Change, How to 194
 - Change, When to 187
 - Checking Engine 145
 - Pressure Indicator 56, 233
 - Selecting Proper Viscosity
 - Chart 193
- ON (Ignition Key Position) 72
- Onboard Refueling Vapor
 - Recovery 251
- Outside Mirrors 89
- Outside Temperature Indicator 62
- Overheating, Engine 231
- Owner's Maintenance Checks 186
- Oxygenated Fuels..... 142

P

- Panel Brightness Control 67
- Park Gear Position..... 162
- Parking 166
- Parking Brake 68
- Parking Brake and Brake
 - System Indicator..... 56, 235
- Parking Lights..... 66
- Parking Over Things that Burn... 166
- Passenger Airbag Off Indicator 30
- PGM-FI System..... 252
- Pollen Filter 209
- Power Door Locks..... 73
- Power Socket Locations..... 90
- Power Steering Fluid..... 202
- Power Windows 86
- Pregnancy, Using Seat Belts 16
- Preparing to Drive 157
- Protecting Adults and Teens..... 11
 - Additional Safety Precautions.... 17
 - Advice for Pregnant Women..... 16
- Protecting Children 32
 - Protecting Infants..... 37
 - Protecting Larger Children 46
 - Protecting Small Children 38

- Using Child Seats with Tethers..... 45
- Using LATCH 41

R

- Radiator Overheating..... 231
- Radio/Tape/CD Sound System... 103
- Radio Theft Protection..... 136
- Readiness Codes..... 234
- Rear Differential Fluid..... 201
- Rear Lights, Bulb Replacement ... 205
- Rear Seat, Folding 82, 83
- Rear View Mirror..... 88
- Rear Window Defogger 68
- Rear Window Wiper and Washer .. 65
- Reclining the Seat Backs 78
- Recommended Shift Speeds 160
- Refueling..... 143
- Reminder Indicators..... 55
- Remote Transmitter..... 75
- Replacement Information
 - Dust and Pollen Filter 209
 - Engine Oil and Filter 194
 - Fuses 237
 - Light Bulbs 203

- Schedule 187
- Tires 211
- Wiper Blades..... 210
- Replacing Seat Belts After a
 - Crash 20
- Reporting Safety Defects* 258
- Reserve Tank, Engine
 - Coolant..... 146, 196
- Restraint, Child 32
- Reverse Gear Position..... 162
- Reverse Lockout..... 165
- Roof Rack 152
- Rotation, Tire 214

S

- Safety Belts..... 8, 18
- Safety Defects, Reporting* 258
- Safety Features 7
 - Airbags..... 9
 - Seat Belts..... 8
- Safety Labels, Location of 51
- Safety Messages ii
- Seat Belts 8, 18
 - Additional Information..... 18
 - Advice for Pregnant Women..... 16

- Automatic Seat Belt
 - Tensioners..... 19
- Cleaning 208
- Detachable Anchor..... 85
- Lap/Shoulder Belt..... 14, 18
- Maintenance..... 20
- Reminder Indicator and
 - Beeper 56
 - System Components..... 18
 - Use During Pregnancy..... 16
 - Wearing a Lap/Shoulder Belt.... 14
- Seat Heaters 86
- Seats, Adjusting the..... 78
- Select/Reset Button 61
- Serial Number 244
- Service Intervals 187
- Service Manual* 259
- Service Station Procedures 143
- Setting the Clock 137
- Shift Lever Position Indicators 161
- Shift Lock Release..... 165

CONTINUED

Index

Side Airbags	9, 26
How Your Side Airbags Work....	26
How the Side Airbag Off Indicator Works.....	29
Side Curtain Airbags	9, 28
How Your Side Curtain Airbags Work.....	28
Side Marker Lights, Bulb Replacement.....	205
Signaling Turns.....	66
Snow Tires.....	215
Sound System.....	103
Spare Tire	220
Spark Plugs.....	246
Specifications	246, 247
Speed Control.....	138
Speed Limiter.....	160, 164
SRS, Additional Information.....	21
Additional Safety Precautions....	31
Airbag Service	30
Airbag System Components.....	21
How the Side Airbag Off Indicator Works.....	29
How the SRS Indicator Works... ..	29
How Your Front Airbags Work.....	23

How Your Side Airbags Work....	26
How Your Side Curtain Airbags Work.....	28
SRS Indicator.....	29, 57
START (Ignition Key Position)	72
Starting the Engine.....	158
In Cold Weather at High Altitude	158
With a Dead Battery	229
State Emissions Testing	254
Steam Coming from Engine.....	231
Steering Wheel Adjustment	69
Anti-theft Column Lock	72
Steering Wheel Buttons.....	135, 138
Stereo Sound System	103
Storing Your Vehicle.....	218
Sun Visor.....	95
Sunglasses Holder	94
Supplemental Restraint System.....	9, 21
Servicing	30
SRS Indicator.....	29, 57
System Components.....	21
Synthetic Oil.....	194

T

Table	
Built in.....	91
Center.....	94
Tailgate	
Hatch Glass	74
Open Indicator	59
Opening the.....	74
Taillights, Changing Bulbs.....	205
Taking Care of the Unexpected ..	219
Tape Player	113, 129
Technical Descriptions	
DOT Tire Quality Grading*	248
Emissions Control Systems.....	251
Oxygenated Fuels.....	142
Three Way Catalytic Converter.....	253
Temperature Gauge	62
Temperature, Outside.....	62
Tether Anchorage Points	45
Theft Protection, Radio.....	136
Three Way Catalytic Converter... ..	253
Tilt the Steering Wheel.....	69
Time, Setting the	137
Tire Chains	216

Tire, How to Change a Flat 220
 Tire Information 250
 Tires 211
 Air Pressure 213
 Chains 216
 Checking Wear 213
 DOT Tire Quality Grading 248
 Inflation 212
 Inspection 213
 Labeling 250
 Maintenance 214
 Replacing 214
 Rotating 214
 Snow 215
 Specifications 247
 Tools, Tire Changing 220
 Towing
 A Trailer 172
 Behind a Motorhome 177
 Emergency Wrecker 242
 Equipment and Accessories 173
 Pre-Tow Checklist 175
 Weight Limit 172
 Trailer Loading 172, 173
 Trailer Towing Tips 175

Transmission
 Checking Fluid Level,
 Automatic 199
 Checking Fluid Level,
 Manual 200
 Fluid Selection 199, 200
 Identification Number 245
 Shifting the Automatic 161
 Shifting the Manual 159
 Treadwear 248
 Trip Meter 61
 Turn Signals 66

U

Unexpected, Taking Care
 of the 219
 Uniform Tire Quality Grading 248
 Unleaded Gasoline 142
 Used Oil, How to Dispose of 195

V

Vehicle Capacity Load 151
 Vehicle Dimensions 246
 Vehicle Identification Number 244

Vehicle Stability Assist (VSA)
 System 170
 Indicators 58
 Vehicle Storage 218
 Ventilation 100
 VIN 244
 Viscosity, Oil 193

W

WARNING, Explanation of ii
 Warning Labels, Location of 51
 Warranty Coverages* 257
 Washers, Windshield
 Checking the Fluid Level 198
 Operation 65
 Wheels
 Adjusting the Steering 69
 Alignment and Balance 214
 Wrench, Nut 223
 Windows
 Auto Reverse 87
 Operating the Power 86
 Rear, Defogger 68

CONTINUED

Index

Windshield	
Cleaning	65
Defroster	101
Washers	198
Wipers, Windshield	
Changing Blades.....	210
Operation	65
Worn Tires	213
Wrecker, Emergency Towing.....	242

* : U.S. only

Service Information Summary

Gasoline:

Unleaded gasoline, pump octane number of 87 or higher.

Fuel Tank Capacity:

15.3 US gal (58 ℓ)

Recommended Engine Oil:

API Premium grade 5W-20 detergent oil (see page [193](#)).

Oil change capacity (including filter):

4.4 US qt (4.2 ℓ)

Automatic Transmission Fluid:

Honda ATF-Z1 (Automatic Transmission Fluid) preferred, or a DEXRON® III ATF as a temporary replacement (see page [199](#)).

Manual Transmission Fluid:

Honda Manual Transmission Fluid preferred, or an SAE 10W-30 or 10W-40 motor oil as a temporary replacement (see page [200](#)).

Capacity (including differential):

2.0 US qt (1.9 ℓ)

Rear Differential Fluid:

Honda Dual Pump Fluid. Do not use ATF.

Capacity:

1.1 US qt (1.0 ℓ)

Power Steering Fluid:

Honda Power Steering Fluid preferred, or another brand of power steering fluid as a temporary replacement. Do not use ATF (see page [202](#)).

Brake Fluid:

Honda Heavy Duty Brake Fluid DOT 3 preferred, or a DOT 3 or DOT 4 brake fluid as a temporary replacement (see page [201](#)).

Tire Pressure (measured cold):

Front/Rear:

29 psi (200 kPa , 2.0 kgf/cm²)