

2010 Fit

Owner's Manual

(Unlinked)

This document does not contain hyperlinks and may be formatted for printing instead of web use. This is due to changes in content and specifications of the vehicle that happen throughout the model year. This manual will be replaced with a hyperlinked version at the end of the model year.

Owner's Identification

OWNER _____

ADDRESS _____
STREET

CITY STATE/PROVINCE/TERRITORY ZIP CODE/
POSTAL CODE

V. I. N. _____

DELIVERY DATE _____
(Date sold to original retail purchaser)

DEALER NAME _____ DEALER NO. _____

ADDRESS _____
STREET

CITY STATE/PROVINCE/TERRITORY ZIP CODE/
POSTAL CODE

OWNER'S SIGNATURE _____

DEALER'S SIGNATURE _____

This owner's manual should be considered a permanent part of the vehicle and should remain with the vehicle when it is sold.

This owner's manual covers all models of the Fit. You may find descriptions of equipment and features that are not on your particular vehicle.

The information and specifications included in this publication were in effect at the time of approval for printing. Honda Motor Co., Ltd. reserves the right, however, to discontinue or change specifications or design at any time without notice and without incurring any obligation whatsoever.

**POUR CLIENTS CANADIEN AVIS
IMPORTANT: Si vous avez besoin
d'un Manuel du Conducteur en
français, veuillez demander à votre
concessionnaire de commander le
numéro de pièce 33TK6C10**

Congratulations! Your selection of a 2010 Honda Fit was a wise investment. It will give you years of driving pleasure.

One of the best ways to enhance the enjoyment of your new vehicle is to read this manual. In it, you will learn how to operate its driving controls and convenience items. Afterwards, keep this owner's manual in your vehicle so you can refer to it at any time.

Several warranties protect your new vehicle. Read the warranty booklet thoroughly so you understand the coverages and are aware of your rights and responsibilities.

Maintaining your vehicle according to the maintenance minder shown in the instrument panel helps to keep your driving trouble-free while it preserves your investment. When your vehicle needs maintenance, keep in mind that your dealer's staff is specially trained in servicing the many systems unique to your vehicle. Your dealer is dedicated to your satisfaction and will be pleased to answer any questions and concerns.

As you read this manual, you will find information that is preceded by a **NOTICE** symbol. This information is intended to help you avoid damage to your vehicle, other property, or the environment.

Introduction

California Proposition 65 Warning

WARNING: This product contains or emits chemicals known to the State of California to cause cancer and birth defects or other reproductive harm.

Event Data Recorders

This vehicle is equipped with one or more devices commonly referred to as event data recorders. These devices record front seat belt use, front passenger seat occupancy, airbag deployment data, and the failure of any airbag system component. This data belongs to the vehicle owner and may not be accessed by anyone else except as legally required or with the permission of the vehicle owner.

Service Diagnostic Recorders

This vehicle is equipped with service-related devices that record information about powertrain performance. The data can be used to verify emissions law requirements and/or help technicians diagnose and solve service problems. It may also be combined with data from other sources for research purposes, but it remains confidential.

A Few Words About Safety

Your safety, and the safety of others, is very important. And operating this vehicle safely is an important responsibility.

To help you make informed decisions about safety, we have provided operating procedures and other information on labels and in this manual. This information alerts you to potential hazards that could hurt you or others.

Of course, it is not practical or possible to warn you about all the hazards associated with operating or maintaining your vehicle. You must use your own good judgement.

You will find this important safety information in a variety of forms, including:

- **Safety Labels** – on the vehicle.
- **Safety Messages** – preceded by a safety alert symbol  and one of three signal words: **DANGER**, **WARNING**, or **CAUTION**.

These signal words mean:

 **DANGER**

You **WILL** be **KILLED** or **SERIOUSLY HURT** if you don't follow instructions.

 **WARNING**

You **CAN** be **KILLED** or **SERIOUSLY HURT** if you don't follow instructions.

 **CAUTION**

You **CAN** be **HURT** if you don't follow instructions.

- **Safety Headings** – such as Important Safety Reminders or Important Safety Precautions.
- **Safety Section** – such as Driver and Passenger Safety.
- **Instructions** – how to use this vehicle correctly and safely.

This entire book is filled with important safety information – please read it carefully.

Contents

Your Vehicle at a Glance (main controls)	3
Driver and Passenger Safety (seat belts, SRS, and child protection)	5
Instruments and Controls (indicators, gauges, dashboard, steering wheel, and other convenience items)	57
Features (heating and cooling, audio, steering wheel, security, and cruise control)	109
Before Driving (fuel, vehicle break-in, and cargo loading)	197
Driving (engine and transmission operation)	213
Maintenance (minder, fluid checking, minor services, and vehicle storage)	243
Taking Care of the Unexpected (flat tire, jump starting, overheating, and fuses)	283
Technical Information (vehicle specifications, tires, and emissions controls)	315
Warranty and Customer Relations (U.S. and Canada only) (warranty and contact information)	331
Index	I
Service Information Summary (fluid capacities and tire pressures)	last page

INDEX

Overview of Contents

Contents

A convenient reference to the sections in this manual.

Your Vehicle at a Glance

A quick reference to the main controls in your vehicle.

Driver and Passenger Safety

Important information about the proper use and care of your vehicle's seat belts, an overview of the supplemental restraint system, and valuable information on how to protect children with child restraints.

Instruments and Controls

Explains the purpose of each instrument panel indicator and gauge, and how to use the controls on the dashboard and steering column.

Features

How to operate the heating and air conditioning system, the audio system, and other convenience features.

Before Driving

What gasoline to use, how to break-in your new vehicle, and how to load luggage and other cargo.

Driving

The proper way to start the engine, shift the transmission, and park.

Maintenance

The maintenance minder shows you when you need to take your vehicle to the dealer for maintenance service. There is also a list of things to check and instructions on how to check them.

Taking Care of the Unexpected

This section covers several problems motorists sometimes experience, and details how to handle them.

Technical Information

ID numbers, dimensions, capacities, and technical information.

Warranty and Customer Relations (U.S. and Canada only)

A summary of the warranties covering your new vehicle, and how to contact us for any reason. Refer to your warranty manual for detailed information.

Index

Service Information Summary

A summary of the information you need when you pull up to the fuel pump.

Your Vehicle at a Glance

Your Vehicle at a Glance

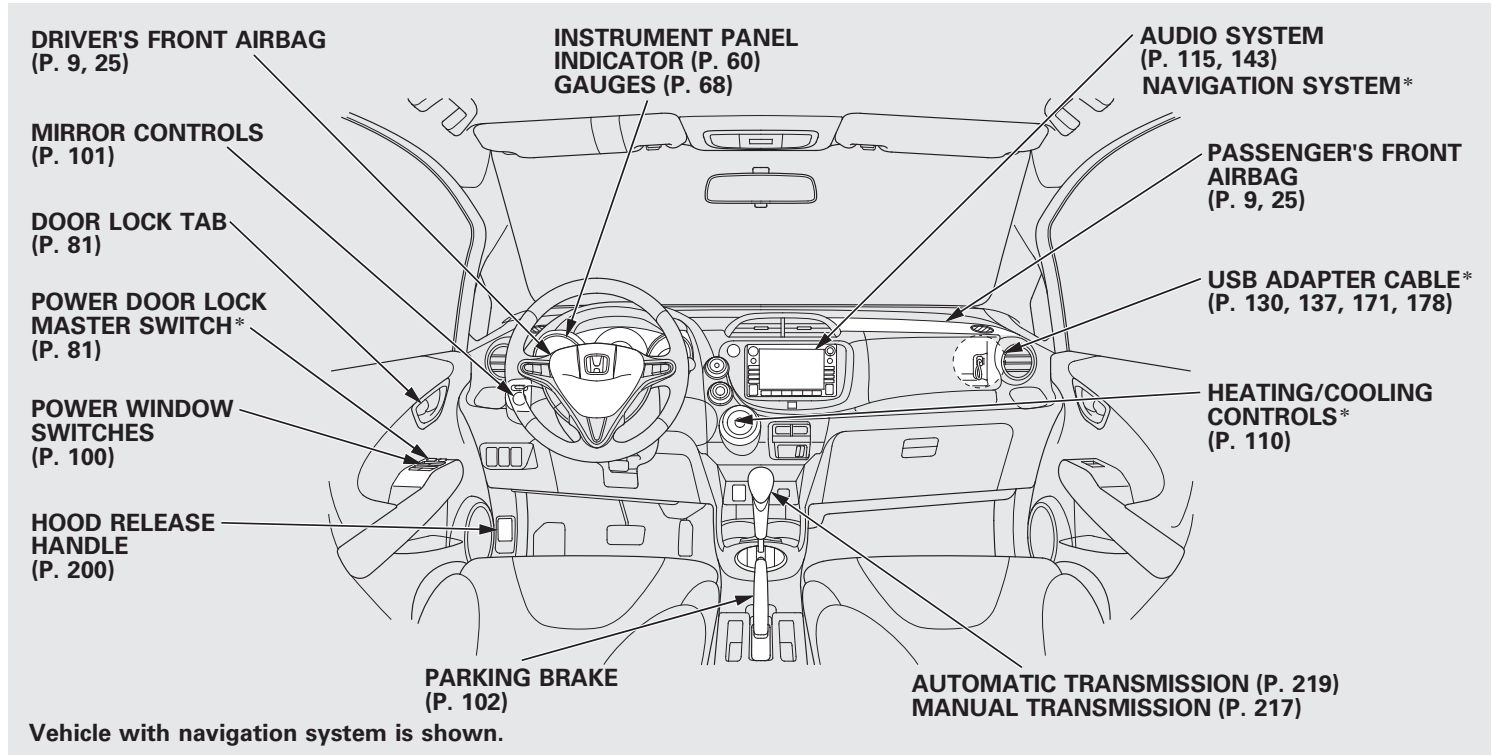

*: If equipped

CONTINUED

Your Vehicle at a Glance

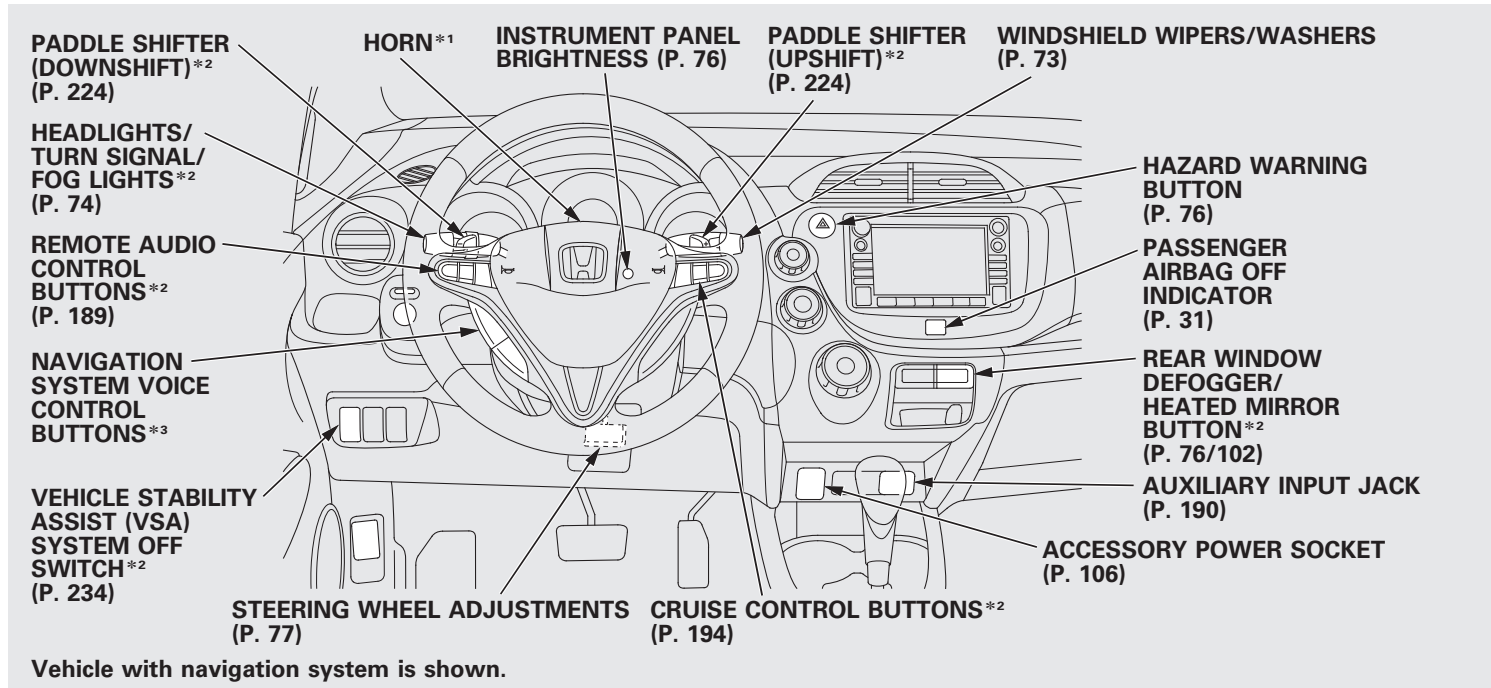

*1: To use the horn, press the center pad of the steering wheel.

*2: If equipped.

*3: Only on vehicles equipped with navigation system. Refer to the navigation system manual.

Driver and Passenger Safety

This section gives you important information about how to protect yourself and your passengers. It shows you how to use seat belts. It explains how your airbags work. And it tells you how to properly restrain infants and children in your vehicle.

Important Safety Precautions.....	6	Lap/Shoulder Belt.....	19	If You Must Drive with Several Children	37
Your Vehicle's Safety Features	7	Automatic Seat Belt Tensioners.....	20	If a Child Requires Close Attention.....	37
Seat Belts.....	8	Seat Belt Maintenance	20	Additional Safety Precautions	38
Airbags	9	Additional Information About Your Airbags	22	Protecting Infants and Small Children.....	39
Protecting Adults and Teens	11	Airbag System Components	22	Protecting Infants	39
1. Close and Lock the Doors.....	11	How Your Front Airbags Work....	25	Protecting Small Children	40
2. Adjust the Front Seats	11	How Your Side Airbags Work.....	28	Selecting a Child Seat	41
3. Adjust the Seat-Backs	12	How Your Side Curtain Airbags Work	30	Installing a Child Seat	42
4. Adjust the Head Restraints	13	How the SRS Indicator Works	30	Installing a Child Seat with LATCH.....	43
5. Fasten and Position the Seat Belts	14	How the Side Airbag Off Indicator Works	31	Installing a Child Seat with a Lap/Shoulder Belt.....	45
6. Maintain a Proper Sitting Position.....	15	How the Passenger Airbag Off Indicator Works	31	Installing a Child Seat with a Tether	47
Advice for Pregnant Women.....	16	Airbag Service.....	32	Protecting Larger Children	49
Additional Safety Precautions	17	Additional Safety Precautions	33	Checking Seat Belt Fit	49
Additional Information About Your Seat Belts	18	Protecting Children – General Guidelines.....	34	Using a Booster Seat.....	50
Seat Belt System Components.....	18	All Children Must Be Restrained.....	34	When Can a Larger Child Sit in Front	51
		All Children Should Sit in a Back Seat	35	Additional Safety Precautions	52
		The Passenger's Front Airbag Can Pose Serious Risks.....	35	Carbon Monoxide Hazard	53
				Safety Labels.....	54

Important Safety Precautions

You'll find many safety recommendations throughout this section, and throughout this manual. The recommendations on this page are the ones we consider to be the most important.

Always Wear Your Seat Belt

A seat belt is your best protection in all types of collisions. Airbags are designed to supplement seat belts, not replace them. So even though your vehicle is equipped with airbags, make sure you and your passengers always wear your seat belts, and wear them properly (see page 14).

Restrain All Children

Children age 12 and under should ride properly restrained in a back seat, not the front seat. Infants and small children should be restrained in a child seat. Larger children should use a booster seat and a lap/shoulder belt until they can use the belt properly without a booster seat (see pages 34 – 52).

Be Aware of Airbag Hazards

While airbags can save lives, they can cause serious or fatal injuries to occupants who sit too close to them, or are not properly restrained. Infants, young children, and short adults are at the greatest risk. Be sure to follow all instructions and warnings in this manual.

Don't Drink and Drive

Alcohol and driving don't mix. Even one drink can reduce your ability to respond to changing conditions, and your reaction time gets worse with every additional drink. So don't drink and drive, and don't let your friends drink and drive, either.

Pay Appropriate Attention to the Task of Driving Safely

Engaging in mobile phone conversation or other activities that keep you from paying close attention to the road, other vehicles and pedestrians could lead to crash. Remember, situations can change quickly, and only you can decide when it is safe to divert attention away from driving.

Control Your Speed

Excessive speed is a major factor in crash injuries and deaths. Generally, the higher the speed, the greater the risk, but serious injuries can also occur at lower speeds. Never drive faster than is safe for current conditions, regardless of the maximum speed posted.

Keep Your Vehicle in Safe Condition

Having a tire blowout or a mechanical failure can be extremely hazardous. To reduce the possibility of such problems, check your tire pressures and condition frequently, and perform all regularly scheduled maintenance (see page 245).

Your Vehicle's Safety Features

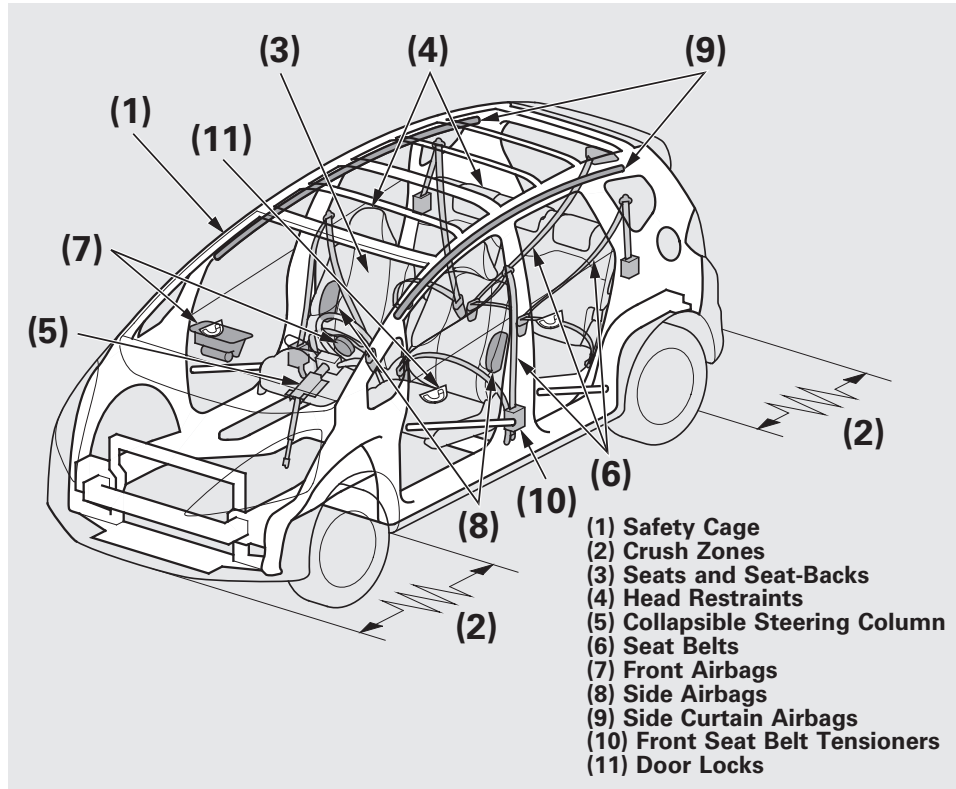

Your vehicle is equipped with many features that work together to protect you and your passengers during a crash.

Some features do not require any action on your part. These include a strong steel framework that forms a safety cage around the passenger compartment, front and rear crush zones, a collapsible steering column, and tensioners that tighten the front seat belts in a crash.

However, you and your passengers can't take full advantage of these features unless you remain sitting in the correct position and ***always wear your seat belts***. In fact, some safety features can contribute to injuries if they are not used properly.

The following pages explain how you can take an active role in protecting yourself and your passengers.

Your Vehicle's Safety Features

Seat Belts

Your vehicle is equipped with seat belts in all seating positions.

Your seat belt system also includes an indicator on the instrument panel and a beeper to remind you and your passengers to fasten your seat belts.

Why Wear Seat Belts

Seat belts are the single most effective safety device for adults and larger children. (Infants and smaller children must be properly restrained in child seats.)

Not wearing a seat belt properly increases the chance of serious injury or death in a crash, even though your vehicle has airbags.

In addition, most states and all Canadian provinces and territories require you to wear seat belts.

⚠ WARNING

Not wearing a seat belt properly increases the chance of serious injury or death in a crash, even though your vehicle has airbags.

Be sure you and your passengers always wear seat belts and wear them properly.

When properly worn, seat belts:

- Keep you connected to the vehicle so you can take advantage of the vehicle's built-in safety features.
- Help protect you in almost every type of crash, including:
 - frontal impacts
 - side impacts
 - rear impacts
 - rollovers

- Help keep you from being thrown against the inside of the vehicle and against other occupants.
- Keep you from being thrown out of the vehicle.
- Help keep you in a good position should the airbags ever deploy. A good position reduces the risk of injury from an inflating airbag and allows you to get the best advantage from the airbag.

Of course, seat belts cannot completely protect you in every crash. But in most cases, seat belts can reduce your risk of serious injury.

What You Should Do:

Always wear your seat belt, and make sure you wear it properly.

Your Vehicle's Safety Features

Airbags

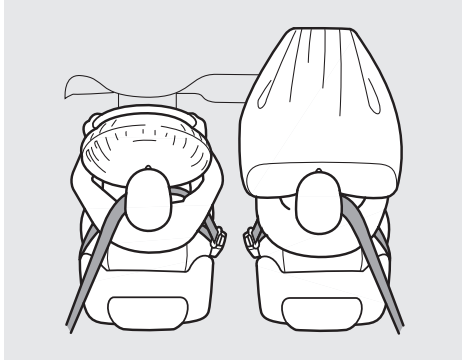

Your vehicle has a supplemental restraint system (SRS) with front airbags to help protect the heads and chests of the driver and a front seat passenger during a moderate to severe frontal collision (see page 25 for more information on how your front airbags work).

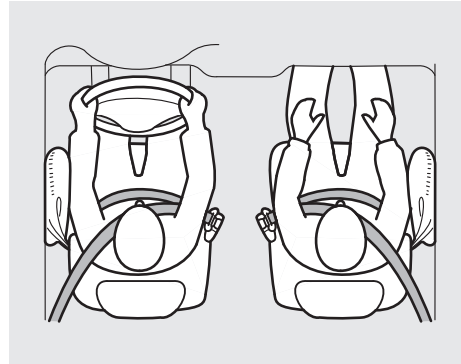

Your vehicle also has side airbags to help protect the upper torso of the driver or a front seat passenger during a moderate to severe side impact (see page 28 for more information on how your side airbags work).

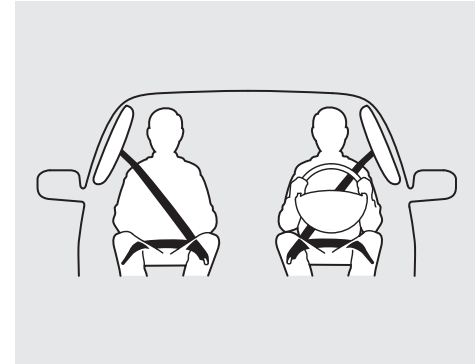

In addition, your vehicle has side curtain airbags to help protect the heads of the driver, front passenger, and passengers in the outer rear seating positions during a moderate to severe side or front impact (see page 30 for more information on how your side curtain airbags work).

CONTINUED

Your Vehicle's Safety Features

The most important things you need to know about your airbags are:

- ***Airbags do not replace seat belts.*** They are designed to supplement the seat belts.
- ***Airbags offer no protection in rear impacts, or minor frontal or side collisions.***
- ***Airbags can pose serious hazards.*** To do their job, airbags must inflate with tremendous force. So while airbags help save lives, they can cause minor injuries or more serious or even fatal injuries if occupants are not properly restrained or sitting properly.

What you should do: Always wear your seat belt properly, and sit upright and as far back from the steering wheel as possible while allowing full control of the vehicle. A front passenger should move their seat as far back from the dashboard as possible.

The rest of this section gives more detailed information about how you can maximize your safety.

Remember, however, that no safety system can prevent all injuries or deaths that can occur in a severe crash, even when seat belts are properly worn and the airbags deploy.

Introduction

The following pages provide instructions on how to properly protect the driver, adult passengers, and teenage children who are large enough and mature enough to drive or ride in the front.

See pages 34 – 38 for important guidelines on how to properly protect infants, small children, and larger children who ride in your vehicle.

1. Close and Lock the Doors

After everyone has entered the vehicle, be sure the doors and the tailgate are closed and locked.



Your vehicle has a door and tailgate open indicator on the instrument panel to indicate when any door or the tailgate is not tightly closed.

Locking the doors reduces the chance of someone being thrown out of the vehicle during a crash, and it helps prevent passengers from accidentally opening a door and falling out.

Locking the doors and the tailgate also helps prevent an outsider from unexpectedly opening a door or the tailgate when you come to a stop.

See page 81 for how to lock the doors, and page 62 for how the door and tailgate open indicator works.

Some models have the auto door locking/unlocking feature. For more information, see page 83.

2. Adjust the Front Seats

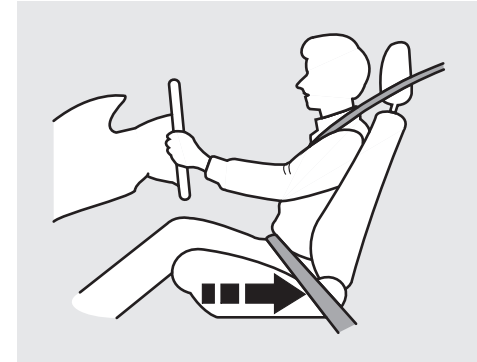

Adjust the driver's seat as far to the rear as possible while allowing you to maintain full control of the vehicle. Have a front passenger adjust their seat as far to the rear as possible.

CONTINUED

Protecting Adults and Teens

If you sit too close to the steering wheel or dashboard, you can be seriously injured by an inflating front airbag, or by striking the steering wheel or dashboard.

The National Highway Traffic Safety Administration and Transport Canada recommend that drivers allow at least 10 inches (25 cm) between the center of the steering wheel and the chest. In addition to adjusting the seat, you can adjust the steering wheel up and down, and in and out (see page 77).

If you cannot get far enough away from the steering wheel and still reach the controls, we recommend that you investigate whether some type of adaptive equipment may help.

⚠ WARNING

Sitting too close to a front airbag can result in serious injury or death if the front airbags inflate.

Always sit as far back from the front airbags as possible.

Once a seat is adjusted correctly, rock it back and forth to make sure it is locked in position.

See page 93 for how to adjust the front seats.

3. Adjust the Seat-Backs

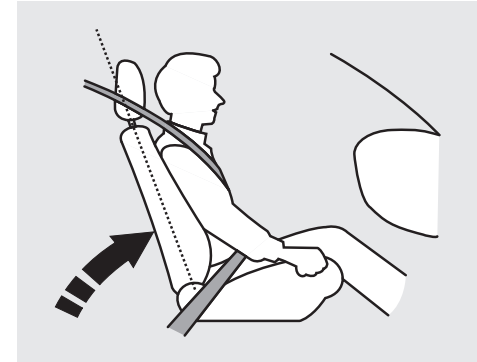

Adjust the driver's seat-back to a comfortable, upright position, leaving ample space between your chest and the airbag cover in the center of the steering wheel.

Passengers with adjustable seat-backs should also adjust their seat-back to a comfortable, upright position.

⚠ WARNING

Reclining the seat-back too far can result in serious injury or death in a crash.

Adjust the seat-back to an upright position, and sit well back in the seat.

Reclining a seat-back so that the shoulder part of the belt no longer rests against the occupant's chest reduces the protective capability of the belt. It also increases the chance of sliding under the belt in a crash and being seriously injured. The farther a seat-back is reclined, the greater the risk of injury.

See page 93 for how to adjust the seat-backs.

4. Adjust the Head Restraints

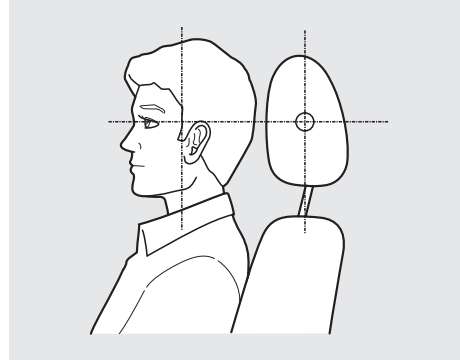

Adjust the driver's head restraint so the center of the back of your head rests against the center of the restraint.

Have passengers adjust their head restraints properly as well. Taller persons should adjust their restraint as high as possible.

When a passenger is seated in the rear center seating position, make sure the center head restraint is properly positioned.

⚠ WARNING

Improperly positioning head restraints reduces their effectiveness and you can be seriously injured in a crash.

Make sure head restraints are in place and positioned properly before driving.

Properly adjusted head restraints will help protect occupants from whiplash and other crash injuries.

See page 94 for how to adjust the head restraints and how the driver's and front passenger's active head restraints work.

Protecting Adults and Teens

5. Fasten and Position the Seat Belts

Insert the latch plate into the buckle, then tug on the belt to make sure the belt is securely latched. Check that the belt is not twisted, because a twisted belt can cause serious injuries in a crash.

The seat belt in the center position of the back seat can be unlatched and retracted to allow the back seat to be folded up or down. This seat belt should be latched whenever the seat-back is in an upright position. See page 99 for how to unlatch and relatch the seat belt.



Position the lap part of the belt as low as possible across your hips, then pull up on the shoulder part of the belt so the lap part fits snugly. This lets your strong pelvic bones take the force of a crash and reduces the chance of internal injuries.

If necessary, pull up on the belt again to remove any slack, then check that the belt rests across the center of your chest and over your shoulder.

This spreads the forces of a crash over the strongest bones in your upper body.

⚠ WARNING

Improperly positioning the seat belts can cause serious injury or death in a crash.

Make sure all seat belts are properly positioned before driving.

If the seat belt touches or crosses your neck, or if it crosses your arm instead of your shoulder, you need to adjust the seat belt anchor height.

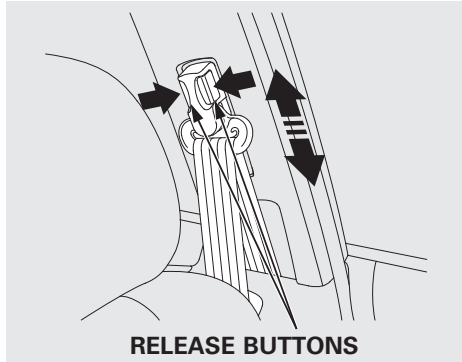

The front seats have adjustable seat belt anchors. To adjust the height of an anchor, squeeze the two release buttons, and slide the anchor up or down as needed (it has four positions).

Never place the shoulder portion of a lap/shoulder belt under your arm or behind your back. This could cause very serious injuries in a crash.

If a seat belt does not seem to work properly, it may not protect the occupant in a crash.

No one should sit in a seat with an inoperative seat belt. Using a seat belt that is not working properly can result in serious injury or death. Have your dealer check the belt as soon as possible.

See page 18 for additional information about your seat belts and how to take care of them.

6. Maintain a Proper Sitting Position

After all occupants have adjusted their seats and head restraints, and put on their seat belts, it is very important that they continue to sit upright, well back in their seats, with their feet on the floor, until the vehicle is safely parked and the engine is off.

Sitting improperly can increase the chance of injury during a crash. For example, if an occupant slouches, lies down, turns sideways, sits forward, leans forward or sideways, or puts one or both feet up, the chance of injury during a crash is greatly increased.

CONTINUED

Protecting Adults and Teens

In addition, an occupant who is out of position in the front seat can be seriously or fatally injured in a crash by striking interior parts of the vehicle or being struck by an inflating front airbag.

⚠ WARNING

Sitting improperly or out of position can result in serious injury or death in a crash.

Always sit upright, well back in the seat, with your feet on the floor.

Advice for Pregnant Women



If you are pregnant, the best way to protect yourself and your unborn child when driving or riding in a vehicle is to always wear a seat belt, and keep the lap part of the belt as low as possible across the hips.

When driving, remember to sit upright and adjust the seat as far back as possible while allowing full control of the vehicle. When riding as a front passenger, adjust the seat as far back as possible.

This will reduce the risk of injuries to both you and your unborn child that can be caused by a crash or an inflating front airbag.

Each time you have a checkup, ask your doctor if it's okay for you to drive.

Additional Safety Precautions

- **Never let passengers ride in the cargo area or on top of a folded-down back seat.** If they do, they could be very seriously injured in a crash.
 - **Never let passengers ride in the area in front of a folded-up rear seat or on top of a folded-down rear seat.** If they do, they could be very seriously injured in a crash.
 - **Passengers should not stand up or change seats while the vehicle is moving.** A passenger who is not wearing a seat belt during a crash or emergency stop can be thrown against the inside of the vehicle, against other occupants, or out of the vehicle.
 - **Two people should never use the same seat belt.** If they do, they could be very seriously injured in a crash.
- **Do not put any accessories on seat belts.** Devices intended to improve occupant comfort or reposition the shoulder part of a seat belt can reduce the protective capability of the belt and increase the chance of serious injury in a crash.
 - **Do not place hard or sharp objects between yourself and a front airbag.** Carrying hard or sharp objects on your lap, or driving with a pipe or other sharp object in your mouth, can result in injuries if your front airbag inflates.
 - **Keep your hands and arms away from the airbag covers.** If your hands or arms are close to an airbag cover, they could be injured if the airbag inflates.
- **Do not attach or place objects on the front airbag covers.** Objects on the covers marked “SRS AIRBAG” could interfere with the proper operation of the airbags or be propelled inside the vehicle and hurt someone if the airbags inflate.
 - **Do not attach hard objects on or near a door.** If a side airbag or a side curtain airbag inflates, a cup holder or other hard object attached on or near the door could be propelled inside the vehicle and hurt someone.
 - **Do not cover or replace front seat-back covers without consulting your dealer.** Improperly replacing or covering front seat-back covers can prevent your side airbags from inflating during a side impact.

Additional Information About Your Seat Belts

Seat Belt System Components

Your seat belt system includes lap/shoulder belts in all seating positions. The front seat belts are also equipped with automatic seat belt tensioners.

This system uses the same sensors as the front airbags to monitor whether the front seat belts are latched or unlatched, and how much weight is on the front passenger's seat (see page 27).



The seat belt system includes an indicator on the instrument panel and a beeper to remind you and your passengers to fasten your seat belts.

This system monitors the front seat belts. If you turn the ignition switch to the ON (II) position before your seat belt is fastened, the beeper will sound and the indicator will flash. If your seat belt is not fastened before the beeper stops, the indicator will stop flashing but remain on.

If a front passenger does not fasten their seat belt, the indicator will come on about 6 seconds after the ignition switch is turned to the ON (II) position.

If either the driver or a front passenger does not fasten their seat belt while driving, the beeper will sound and the indicator will flash again at regular intervals.

When no one is sitting in the front passenger's seat, or a child or small adult is riding there, the indicator should not come on and the beeper should not sound.

If the indicator comes on or the beeper sounds when the driver's seat belt is latched and there is no front seat passenger and no items on the front seat, something may be interfering with the monitoring system. Look for and remove:

- Any items under the front passenger's seat.
- Any object(s) hanging on the seat or in the seat-back pocket.
- Any object(s) touching the rear of the seat-back.

If no obstructions are found, have your vehicle checked by a dealer.

Additional Information About Your Seat Belts

Lap/Shoulder Belt

The lap/shoulder belt goes over your shoulder, across your chest, and across your hips.

To fasten the belt, insert the latch plate into the buckle, then tug on the belt to make sure the buckle is latched (see page 14 for how to properly position the belt).

To unlock the belt, press the red PRESS button on the buckle. Guide the belt across your body so that it retracts completely. After exiting the vehicle, be sure the belt is out of the way and will not get closed in the door.

All seat belts have an emergency locking retractor. In normal driving, the retractor lets you move freely in your seat while it keeps some tension on the belt. During a collision or sudden stop, the retractor automatically locks the belt to help restrain your body.

The seat belts in all positions except the driver's have a lockable retractor that must be activated to secure a child seat (see page 45).

If the shoulder part of the belt is pulled all the way out, the lockable retractor will activate. The belt will retract, but it will not allow the passenger to move freely.

To deactivate the lockable retractor, unlatch the buckle and let the seat belt fully retract. To refasten the seat belt, pull it out only as far as needed.

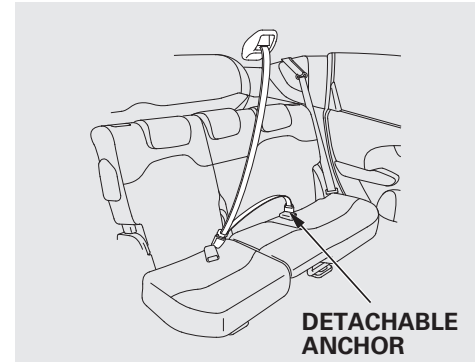

The lap/shoulder belt in the center seating position on the rear seat is equipped with a detachable seat belt that has two parts: a small latch plate and an anchor buckle.

The detachable seat belt should normally be latched whenever the seat-backs are in an upright position. For more information about the detachable seat belt, see page 99.

Additional Information About Your Seat Belts

Automatic Seat Belt Tensioners

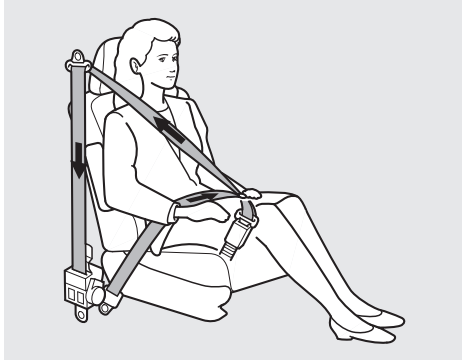

For added protection, the front seat belts are equipped with automatic seat belt tensioners. When activated, the tensioners immediately tighten the belts to help hold the driver and a front passenger in position.

The tensioners are designed to activate in any collision severe enough to cause the front airbags to deploy.

If a side curtain airbag deploys during a side impact, the tensioner on that side of the vehicle will also deploy.

The tensioners can also be activated during a collision in which the front airbags *do not deploy*. In this case, the airbags would not be needed, but the extra tension in the seat belt could be helpful.

When the tensioners are activated, the seat belts will remain tight until they are unbuckled.

Seat Belt Maintenance

For safety, you should check the condition of your seat belts regularly.

Pull each belt out fully, and look for frays, cuts, burns, and wear. Check that the latches work smoothly and the belts retract easily. If a belt does not retract easily, cleaning the belt may correct the problem (see page 267). Any belt that is not in good condition or working properly will not provide good protection and should be replaced as soon as possible.

Honda provides a limited warranty on seat belts. See your *Honda Warranty Information* booklet for details.

Additional Information About Your Seat Belts

If a seat belt is worn during a crash, it must be replaced by your dealer. A belt that has been worn during a crash may not provide the same level of protection in a subsequent crash.

The dealer should also inspect the anchors for damage and replace them if needed. If the automatic seat belt tensioners activate during a crash, they must be replaced.

WARNING

Not checking or maintaining seat belts can result in serious injury or death if the seat belts do not work properly when needed.

Check your seat belts regularly and have any problem corrected as soon as possible.

Additional Information About Your Airbags

Airbag System Components

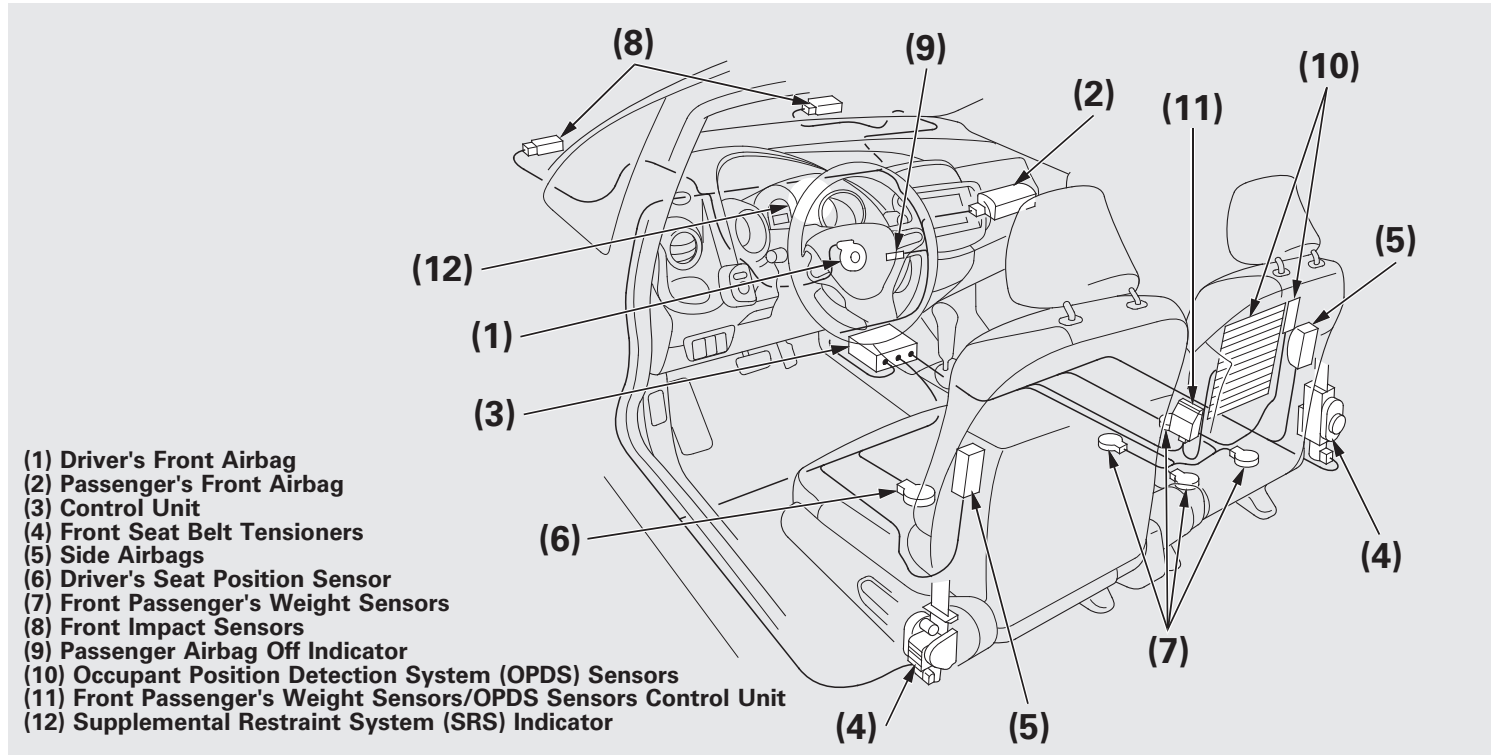

Additional Information About Your Airbags

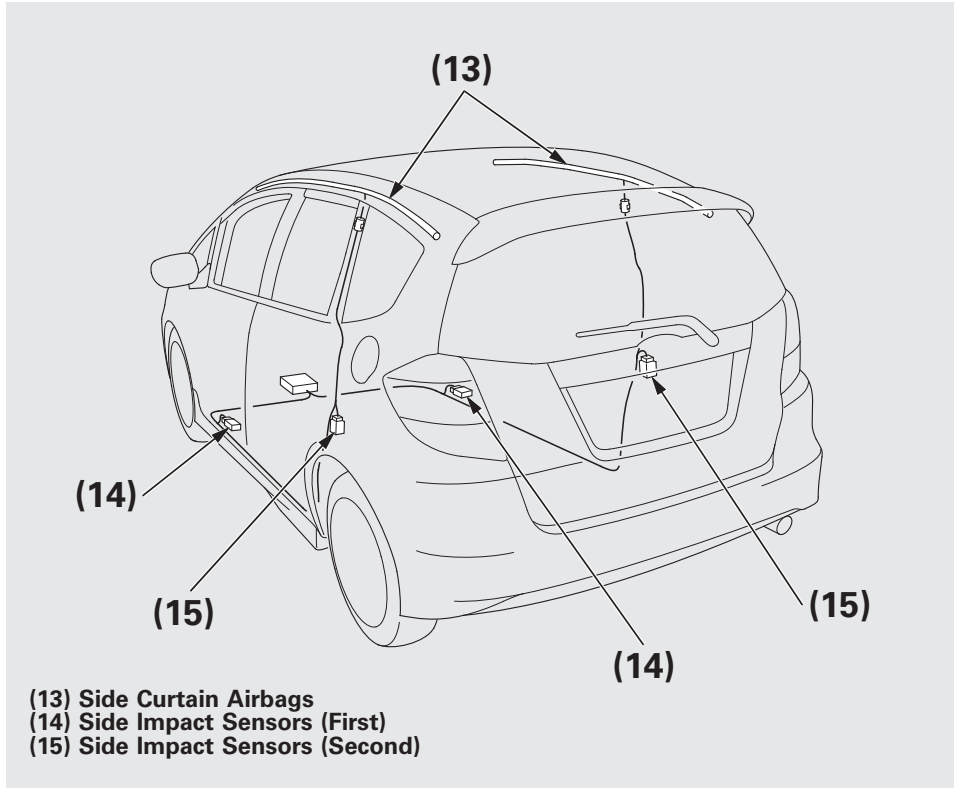

Your airbag system includes:

- Two SRS (supplemental restraint system) front airbags. The driver's airbag is stored in the center of the steering wheel; the front passenger's airbag is stored in the dashboard. Both are marked "SRS AIRBAG" (see page 25).
- Two side airbags, one for the driver and one for a front passenger. The airbags are stored in the outer edges of the seat-backs. Both are marked "SIDE AIRBAG" (see page 28).
- Two side curtain airbags, one for each side of the vehicle. The airbags are stored in the ceiling, above the side windows. The front and rear pillars are marked "SIDE CURTAIN AIRBAG" (see page 30).

CONTINUED

Additional Information About Your Airbags

- Automatic front seat belt tensioners (see page 20).
- Sensors that can detect a moderate to severe front impact or side impact.
- Sensors that can detect whether a child is in the passenger's side airbag path and signal the control unit to turn the airbag off (see page 29).
- Sensors that can detect whether the driver's seat belt and the front passenger's seat belt are latched or unlatched (see page 18).
- A driver's seat position sensor that monitors the distance of the seat from the front airbag. If the seat is too far forward, the airbag will inflate with less force (see page 27).
- Weight sensors that monitor the weight on the front passenger's seat. If the weight is about 65 lbs (29 kg) or less (the weight of an infant or small child), the passenger's front airbag will be turned off (see page 27).
- A sophisticated electronic system that continually monitors and records information about the sensors, the control unit, the airbag activators, the seat belt tensioners, and driver and front passenger seat belt use when the ignition switch is in the ON (II) position.
- An indicator on the instrument panel that alerts you to a possible problem with your airbags, sensors, or seat belt tensioners (see page 30).
- An indicator on the instrument panel that alerts you that the passenger's side airbag has been turned off (see page 31).
- An indicator on the dashboard that alerts you that the passenger's front airbag has been turned off (see page 31).
- Emergency backup power in case your vehicle's electrical system is disconnected in a crash.

Additional Information About Your Airbags

How Your Front Airbags Work

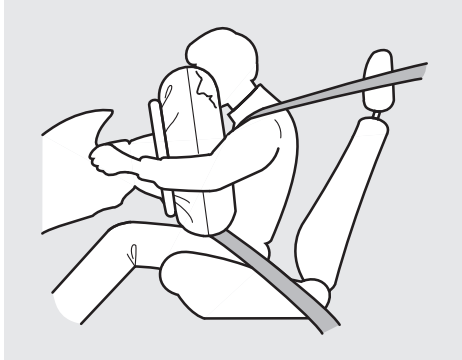

If you ever have a moderate to severe frontal collision, sensors will detect the vehicle's rapid deceleration.

If the rate of deceleration is high enough, the control unit will inflate the driver's and front passenger's airbags, at the time and with the force needed.

During a frontal crash, your seat belt restrains your lower body and torso, and the front airbag helps protect your head and chest.

Although both airbags normally inflate within a split second of each other, it is possible for only one airbag to deploy.

This can happen if the severity of a collision is at the margin, or threshold, that determines whether or not the airbags will deploy. In such cases, the seat belt will provide sufficient protection, and the supplemental protection offered by the airbag would be minimal.

Only the driver's airbag can deploy if there is no passenger in the front seat, or if the advanced airbag system has turned the passenger's airbag off (see page 27).

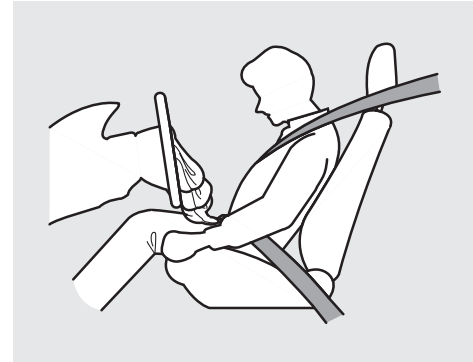

After inflating, the front airbags immediately deflate, so they won't interfere with the driver's visibility, or the ability to steer or operate other controls.

The total time for inflation and deflation is one-tenth of a second, so fast that most occupants are not aware that the airbags deployed until they see them lying in their laps.

CONTINUED

Additional Information About Your Airbags

After a crash, you may see what looks like smoke. This is actually powder from the airbag's surface. Although the powder is not harmful, people with respiratory problems may experience some temporary discomfort. If this occurs, get out of the vehicle as soon as it is safe to do so.

Dual-Stage Airbags

Your front airbags are dual-stage airbags. This means they have two inflation stages that can be ignited sequentially or simultaneously, depending on crash severity.

In a ***more severe*** crash, both stages will ignite simultaneously to provide the quickest and greatest protection.

In a ***less severe*** crash, one stage will ignite first, then the second stage will ignite a split second later. This provides longer airbag inflation time with a little less force.

Dual-Threshold Airbags

Your front airbags are also dual-threshold airbags. Airbags with this feature have two deployment thresholds that depend on whether sensors detect the occupant is wearing a seat belt or not.

If the occupant's belt is ***not latched***, the airbag will deploy at a slightly lower threshold, because the occupant would need extra protection.

If the occupant's belt is ***latched***, the airbag will deploy at a slightly higher threshold, when the airbag would be needed to supplement the protection provided by the seat belt.

Additional Information About Your Airbags

Advanced Airbags

Your front airbags are also advanced airbags. The main purpose of this feature is to help prevent airbag-caused injuries to short drivers and children or small statured adults who ride in front.

For both advanced airbags to work properly:

- Occupants must sit upright and wear their seat belts properly.
- Do not spill any liquids on or under the seats, cover the sensors, or put any objects or metal items under the front seats.

Failure to follow these instructions could damage the sensors or prevent them from working properly.

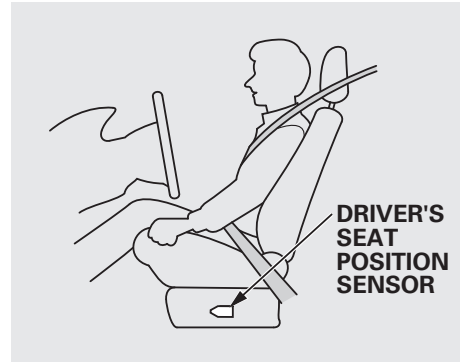

The driver's advanced front airbag system includes a seat position sensor under the seat. If the seat is too far forward, the airbag will inflate with less force, regardless of the severity of the impact.

If there is a problem with the sensor, the SRS indicator will come on, and the airbag will inflate in the normal manner regardless of the driver's seating position.

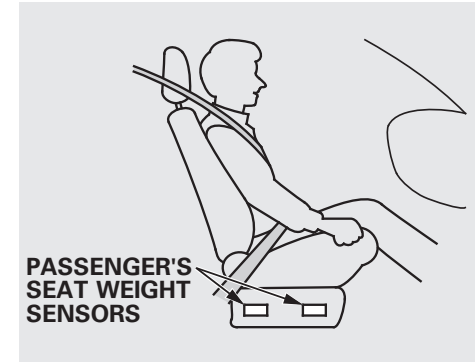

The passenger's advanced front airbag system has weight sensors under the seat. Although Honda does not encourage carrying an infant or small child in front, if the sensors detect the weight of an infant or small child (up to about 65 lbs or 29 kg), the system will automatically turn the passenger's front airbag off.

Be aware that objects placed on the passenger's seat can also cause the airbag to be turned off.

CONTINUED

Additional Information About Your Airbags

When the passenger airbag gets turned off by the weight sensors, a “passenger airbag off” indicator in the center of the dashboard comes on (see page 31).

If the weight sensors detect there is no passenger in the front seat, the airbag is automatically turned off. However, the passenger airbag off indicator in this situation will not come on.

To ensure that the passenger's advanced front airbag system will work properly, ***do not do anything that would increase or decrease the weight on the front passenger's seat.*** This includes:

- A rear passenger pushing or pulling on the back of the front passenger's seat.

- Moving the front seat forcibly back against cargo on the seat or floor behind it.
- Hanging heavy items on the front passenger seat, or placing heavy items in the seat-back pocket.
- Moving the front seat or seat-back forcibly back against the folded rear seat.
- Back seat passengers should not wedge objects or intentionally force their feet under the front passenger seat.

If your vehicle has optional floor mats, make sure the mat behind the driver's seat is hooked to the floor mat anchor (see page 267). If it is not, the mat may interfere with the proper operation of the sensors and operation of the seat.

How Your Side Airbags Work

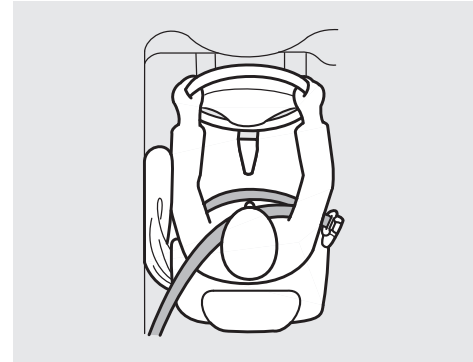

If you ever have a moderate to severe side impact, sensors will detect rapid acceleration and signal the control unit to instantly inflate either the driver's or the passenger's side airbag.

Additional Information About Your Airbags

Only one airbag will deploy during a side impact. If the impact is on the passenger's side, the passenger's side airbag will deploy even if there is no passenger.

To get the best protection from the side airbags, front seat occupants should wear their seat belts and sit upright and well back in their seats.

Side Airbag Cutoff System

Your vehicle has a side airbag cutoff system designed primarily to protect a child riding in the front passenger's seat.

Although Honda does not encourage children to ride in front, if the position sensors detect a child has leaned into the side airbag's deployment path, the airbag will shut off.

The side airbag may also shut off if a short adult leans sideways, or a larger adult slouches and leans sideways into the airbag's deployment path.

Objects placed on the front passenger seat can also cause the side airbag to be shut off.

If the side airbag off indicator comes on (see page 31), have the passenger sit upright. Once the passenger is out of the airbag's deployment path, the system will turn the airbag back on, and the indicator will go out.

There will be some delay between the moment the passenger moves into or out of the airbag deployment path and when the indicator comes on or goes off.

A front seat passenger should not use a cushion or another object as a backrest. It may prevent the cutoff system from working properly.

Additional Information About Your Airbags

How Your Side Curtain Airbags Work

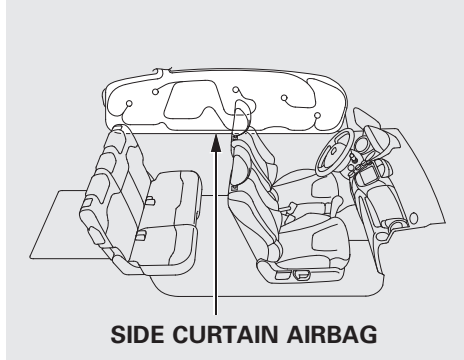

In a moderate to severe side impact, sensors will detect rapid acceleration and signal the control unit to instantly inflate the side curtain airbag and activate the seat belt tensioner on the driver's or the passenger's side of the vehicle.

If the impact is on the passenger's side, the passenger's side curtain airbag will inflate even if there are no occupants on that side of the vehicle.

One or both side curtain airbags may inflate in a moderate to severe frontal collision which causes the front airbags to deploy.

To get the best protection from the side curtain airbags, occupants should wear their seat belts and sit upright and well back in their seats.

How the SRS Indicator Works



The SRS indicator alerts you to a potential problem with your airbags or seat belt tensioners.

When you turn the ignition switch to the ON (II) position, this indicator comes on briefly then goes off. This tells you the system is working properly.

If the indicator comes on at any other time, or does not come on at all, you should have the system checked by your dealer. For example:

- If the SRS indicator does not come on after you turn the ignition switch to the ON (II) position.
- If the indicator stays on after the engine starts.
- If the indicator comes on or flashes on and off while you drive.

Additional Information About Your Airbags

If you see any of these indications, the airbags and seat belt tensioners may not work properly when you need them.

⚠ WARNING

Ignoring the SRS indicator can result in serious injury or death if the airbag systems or tensioners do not work properly.

Have your vehicle checked by a dealer as soon as possible if the SRS indicator alerts you to a possible problem.

How the Side Airbag Off Indicator Works

U.S.



Canada



This indicator alerts you that the passenger's side airbag has been automatically shut off. It does **not** mean there is a problem with your side airbags.

When you turn the ignition switch to the ON (II) position, the indicator should come on briefly and then go off (see page 61). If it doesn't come on, stays on, or comes on while driving without a passenger in the front seat, have the system checked.

How the Passenger Airbag Off Indicator Works

PASSENGER AIRBAG OFF INDICATOR

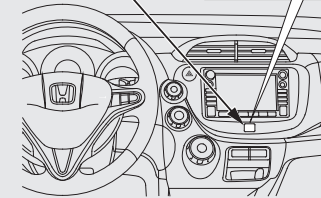

On vehicle with navigation system

This indicator alerts you that the passenger's front airbag has been shut off because weight sensors detect about 65 lbs (29 kg) or less (the weight of an infant or small child) on the front passenger's seat. It does **not mean** there is a problem with the airbag.

CONTINUED

Additional Information About Your Airbags

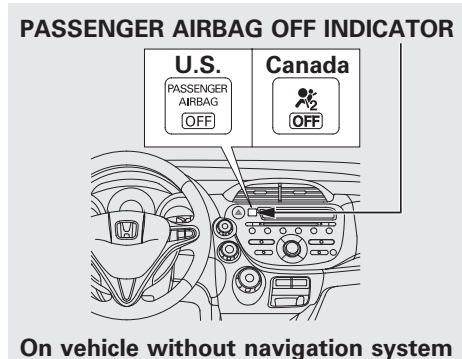

Be aware that objects placed on the front seat can cause the indicator to come on.

If the weight sensors detect there is no passenger in the front seat, the airbag will be off. However, the passenger airbag off indicator will not come on.

The passenger airbag off indicator may come on and off repeatedly if the total weight on the seat is near the airbag cutoff threshold.

If an adult or teenage passenger is riding in front, move the seat as far to the rear as possible, and have the passenger sit upright and wear the seat belt properly.

If the indicator comes on with no front seat passenger and no objects on the seat, or with an adult riding there, something may be interfering with the weight sensors. Look for and remove:

- Any items under the front passenger's seat.
- Any object hanging on the seat or in the seat-back pocket.
- Any object(s), such as a folded-down back seat, that are touching the rear of the seat-back.

If no obstructions are found, have your vehicle checked by a dealer as soon as possible.

Airbag Service

Your airbag systems are virtually maintenance free, and there are no parts you can safely service. However, you must have your vehicle serviced if:

- ***An airbag ever inflates.*** Any airbag that has deployed must be replaced along with the control unit and other related parts. Any seat belt tensioner that activates must also be replaced.

Do not try to remove or replace any airbag by yourself. This must be done by an authorized dealer or a knowledgeable body shop.

- ***The SRS indicator alerts you to a problem.*** Take your vehicle to an authorized dealer as soon as possible. If you ignore this indication, your airbags may not operate properly.

Additional Information About Your Airbags

- ***If your vehicle has a moderate to severe impact.*** Even if your airbags do not inflate, your dealer should inspect the driver's seat position sensor, the front passenger's weight sensors, the front seat belt tensioners, and all seat belts worn during a crash to make sure they are operating properly.

Additional Safety Precautions

- ***Do not attempt to deactivate your airbags.*** Together, airbags and seat belts provide the best protection.
- ***Do not tamper with airbag components or wiring for any reason.*** Tampering could cause the airbags to deploy, possibly causing very serious injury.
- ***Do not expose the front passenger's seat-back to liquid.*** If water or another liquid soaks into a seat-back, it can prevent the side airbag cutoff system from working properly.

- ***Do not remove or modify a front seat without consulting your dealer.*** This could make the driver's seat position sensor or the front passenger's weight sensors ineffective. If it is necessary to remove or modify a front seat to accommodate a person with disabilities, first contact Honda Automobile Customer Service at (800) 999-1009.

Protecting Children – General Guidelines



Children depend on adults to protect them. However, despite their best intentions, many adults do not know how to *properly* protect child passengers.

If you have children, or ever need to drive with a child in your vehicle, be sure to read this section. It begins with important general guidelines, then presents special information for infants, small children, and larger children.

All Children Must Be Restrained

Each year, many children are injured or killed in vehicle crashes because they are either unrestrained or not properly restrained. In fact, vehicle accidents are the number one cause of the death of children aged 12 and under.

To reduce the number of child deaths and injuries, every state, Canadian province and territory requires that infants and children be properly restrained when they ride in a vehicle.

Infants and small children must be restrained in an approved child seat that is properly secured to the vehicle (see pages 39 – 48).

▲ WARNING

Children who are unrestrained or improperly restrained can be seriously injured or killed in a crash.

Any child too small for a seat belt should be properly restrained in a child seat. A larger child should be properly restrained with a seat belt and use a booster seat if necessary.

Larger children must be restrained with a lap/shoulder belt and ride on a booster seat until the seat belt fits them properly (see pages 49 – 52).

Protecting Children – General Guidelines

All Children Should Sit in a Back Seat

According to accident statistics, children of all ages and sizes are safer when they are restrained in a back seat.

The National Highway Traffic Safety Administration and Transport Canada recommend that all children aged 12 and under be properly restrained in a back seat. Some states have laws restricting where children may ride.

Children who ride in back are less likely to be injured by striking interior vehicle parts during a collision or hard braking. Also, children cannot be injured by an inflating front airbag when they ride in the back.

The Passenger's Front Airbag Can Pose Serious Risks

Front airbags have been designed to help protect adults in a moderate to severe frontal collision. To do this, the passenger's front airbag is quite large, and it can inflate with enough force to cause very serious injuries.

Even though your vehicle has an advanced front airbag system that automatically turns the passenger's front airbag off under certain circumstances (see page 31), please follow these guidelines:

Infants

Never put a rear-facing child seat in the front seat of a vehicle equipped with a passenger's front airbag. If the airbag inflates, it can hit the back of the child seat with enough force to kill or very seriously injure an infant.

Small Children

Placing a forward-facing child seat in the front seat of a vehicle equipped with a passenger's front airbag can be hazardous. If the vehicle seat is too far forward, or the child's head is thrown forward during a collision, an inflating front airbag can strike the child with enough force to kill or very seriously injure a small child.

Larger Children

Children who have outgrown child seats are also at risk of being injured or killed by an inflating passenger's front airbag. Whenever possible, larger children should sit in the back seat, on a booster seat if needed, and be properly restrained with a seat belt (see page 49 for important information about protecting larger children).

CONTINUED

Protecting Children – General Guidelines

To remind you of the passenger's front airbag hazards, and that children must be properly restrained in a back seat, your vehicle has warning labels on the dashboard (U.S. models) and on the front visors. Please read and follow the instructions on these labels.

U.S. Models

SUN VISORS



DASHBOARD

This Vehicle is Equipped with
Advanced Air Bags

Even with Advanced Air Bags

Children can be killed or seriously injured by the air bag.
The back seat is the safest place for children.
Never put a rear-facing child seat in the front.
Always use seat belts and child restraints.
See owner's manual for more information about air bags.

To be removed by owner only.

Canadian Models

SUN VISORS

CAUTION

TO AVOID SERIOUS INJURY:

- FOR MAXIMUM SAFETY PROTECTION IN ALL TYPES OF CRASHES, YOU MUST ALWAYS WEAR YOUR SAFETY BELT.
- DO NOT INSTALL REARWARD-FACING CHILD SEATS IN ANY FRONT PASSENGER SEAT POSITION.
- DO NOT SIT OR LEAN UNNECESSARILY CLOSE TO THE AIR BAG.
- DO NOT PLACE ANY OBJECTS OVER THE AIR BAG OR BETWEEN THE AIR BAG AND YOURSELF.
- SEE THE OWNER'S MANUAL FOR FURTHER INFORMATION AND EXPLANATIONS.

PRECAUTIONS:

- POUR EVITER DES BLESSURES GRAVES: POUR PROFITER D'UNE PROTECTION MAXIMALE LORS D'UNE COLLISION BOUCLEZ TOUJOURS VOTRE CEINTURE DE SECURITE.
- N'INSTALLEZ JAMAIS UN SIEGE POUR ENFANTS FAISANT FACE A L'ARRIERE SUR LE SIEGE DU PASSAGER AVANT.
- NE VOUS APPUYEZ PAS ET NE VOUS ASSOYEZ PAS PRES DU COUSSIN GONFLABLE.
- NE DEPOSEZ AUCUN OBJET SUR LE COUSSIN GONFLABLE OU ENTRE LE COUSSIN GONFLABLE ET VOUS.
- LISEZ LE GUIDE UTILISATEUR POUR DE PLUS AMPLES RENSEIGNEMENTS.

If You Must Drive with Several Children

Your vehicle has a back seat where children can be properly restrained. If you ever have to carry a group of children, and a child must ride in front:

- Place the largest child in the front seat, provided the child is large enough to wear the lap/shoulder belt properly (see page 49).
- Move the vehicle seat as far to the rear as possible (see page 93).
- Have the child sit upright and well back in the seat (see page 15).
- Make sure the seat belt is properly positioned and secured (see page 14).

If a Child Requires Close Attention

Many parents say they prefer to put an infant or a small child in the front passenger seat so they can watch the child, or because the child requires attention.

Placing a child in the front seat exposes the child to hazards in a frontal collision, and paying close attention to a child distracts the driver from the important tasks of driving, placing both of you at risk.

If a child requires close physical attention or frequent visual contact, we strongly recommend that another adult ride with the child in a back seat. The back seat is far safer for a child than the front.

Protecting Children – General Guidelines

Additional Safety Precautions

- **Never hold an infant or child on your lap.** If you are not wearing a seat belt in a crash, you could be thrown forward and crush the child against the dashboard or a seat-back. If you are wearing a seat belt, the child can be torn from your arms and be seriously hurt or killed.
 - **Never put a seat belt over yourself and a child.** During a crash, the belt could press deep into the child and cause serious or fatal injuries.
 - **Never let two children use the same seat belt.** If they do, they could be very seriously injured in a crash.
 - **Make sure any unused seat belt that a child can reach is buckled, the lockable retractor is activated, and the belt is fully retracted and locked.** If a child wraps a loose seat belt around their neck, they can be seriously or fatally injured. (See pages 45 and 46 for how to activate and deactivate the lockable retractor.)
 - **Use the childproof door locks to prevent children from opening the rear doors.** This can prevent children from accidentally falling out (see page 82).
 - **Do not leave children alone in a vehicle.** Leaving children without adult supervision is illegal in most states, Canadian provinces and territories, and can be very hazardous.
- For example, infants and small children left in a vehicle on a hot day can die from heatstroke. A child left alone with the key in the ignition switch can accidentally set the vehicle in motion, possibly injuring themselves or others.
- **Lock all doors and the tailgate when your vehicle is not in use.** Children who play in vehicles can accidentally get trapped inside. Teach your children not to play in or around vehicles.
 - **Keep vehicle keys/remote transmitters out of the reach of children.** Even very young children learn how to unlock vehicle doors, turn on the ignition switch, and open the tailgate, which can lead to accidental injury or death.

Protecting Infants and Small Children

Protecting Infants

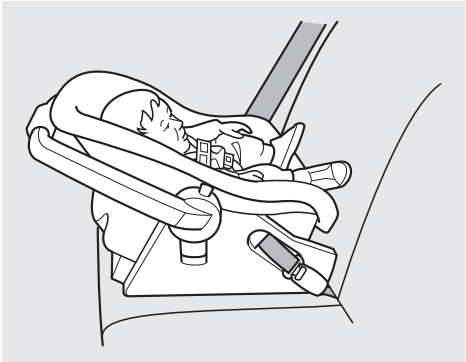

Child Seat Type

An infant must be properly restrained in a rear-facing, reclining child seat until the child reaches the seat maker's weight or height limit for the seat, and the child is at least one year old.

Only a rear-facing child seat provides proper support for a baby's head, neck, and back.

Two types of seats may be used: a seat designed exclusively for infants, or a convertible seat used in the rear-facing, reclining mode.

Do not put a rear-facing child seat in a forward-facing position. If placed facing forward, an infant could be very seriously injured during a frontal collision.

Rear-facing Child Seat Placement

A rear-facing child seat can be placed in any seating position in the back seat, but not in the front. ***Never put a rear-facing child seat in the front seat.***

If the passenger's front airbag inflates, it can hit the back of the child seat with enough force to kill or seriously injure an infant.

When properly installed, a rear-facing child seat may prevent the driver or a front passenger from moving their seat as far back as recommended, or from locking their seat-back in the desired position.

It could also interfere with proper operation of the passenger's advanced front airbag system.

CONTINUED

Protecting Infants and Small Children

In any of these situations, we strongly recommend that you install the child seat directly behind the front passenger's seat, move the seat as far forward as needed, and leave it unoccupied. Or, you may wish to get a smaller rear-facing child seat.

⚠ WARNING

Placing a rear-facing child seat in the front seat can result in serious injury or death during a collision.

Always place a rear-facing child seat in the back seat, not the front.

Protecting Small Children



Child Seat Type

Many states, Canadian provinces and territories allow a child one year of age or older who also meets the minimum size and weight requirements to transition from a rear-facing child seat to a forward-facing seat. Know the requirements where you are driving and follow the child seat instructions. Many experts recommend use of a rear-facing seat up to age two, if the child's height and weight are appropriate for a rear-facing seat.

Of the different seats available, we recommend those that have a five-point harness system as shown.

We also recommend that a small child use the child seat until the child reaches the weight or height limit for the seat.

Child Seat Placement

We strongly recommend placing a forward-facing child seat in a back seat, not the front.

Placing a forward-facing child seat in the front seat of a vehicle equipped with a passenger's airbag can be hazardous. If the vehicle seat is too far forward, or the child's head is thrown forward during a collision, an inflating airbag can strike the child with enough force to cause very serious or fatal injuries.

Protecting Infants and Small Children, Selecting a Child Seat

Even with advanced front airbags that automatically turn the passenger's front airbag off (see page 31), a back seat is the safest place for a small child.

If it is necessary to put a forward-facing child seat in the front, move the vehicle seat as far to the rear as possible, and be sure the child seat is firmly secured to the vehicle and the child is properly strapped in the seat.

⚠ WARNING

Placing a forward-facing child seat in the front seat can result in serious injury or death if the front airbag inflates.

If you must place a forward-facing child seat in front, move the vehicle seat as far back as possible, and properly restrain the child.

Selecting a Child Seat

When buying a child seat, you need to choose either a conventional child seat, or one designed for use with the Lower Anchors and Tethers for Children (LATCH) system.

Conventional child seats must be secured to a vehicle with a seat belt, whereas LATCH-compatible seats are secured by attaching the seat to hardware built into the two outer seating positions in the back seat.

Since LATCH-compatible child seats are easier to install and reduce the possibility of improper installation, we recommend selecting this style.

In seating positions and vehicles not equipped with LATCH, a LATCH-compatible child seat can be installed using a seat belt.

Whatever type of seat you choose, to provide proper protection, a child seat should meet three requirements:

1. ***The child seat should meet Federal Motor Vehicle Safety Standard 213 or Canadian Motor Vehicle Safety Standard 213.*** Look for FMVSS 213 or CMVSS 213 on the box.
2. ***The child seat should be of the proper type and size to fit the child.*** Rear-facing for infants, forward-facing for small children.
3. ***The child seat should fit the vehicle seating position (or positions) where it will be used.***

Before purchasing a conventional child seat, or using a previously purchased one, we recommend that you test the seat in the specific vehicle seating position or positions where the seat will be used.

Installing a Child Seat

After selecting a proper child seat and a good place to install the seat, there are three main steps in installing the seat:

1. ***Properly secure the child seat to the vehicle.*** All child seats must be secured to the vehicle with the lap part of a lap/shoulder belt or with the LATCH (Lower Anchors and Tethers for CHildren) system. A child whose seat is not properly secured to the vehicle can be endangered in a crash.
2. ***Make sure the child seat is firmly secured.*** After installing a child seat, push and pull the seat forward and from side-to-side to verify that it is secure.

A child seat secured with a seat belt should be installed as firmly as possible. However, it does not need to be “rock solid.” Some side-to-side movement can be expected and should not reduce the child seat's effectiveness.

If the child seat is not secure, try installing it in a different seating position, or use a different style of child seat that can be firmly secured.

3. ***Secure the child in the child seat.*** Make sure the child is properly strapped in the child seat according to the child seat maker's instructions. A child who is not properly secured in a child seat can be seriously injured in a crash.

The following pages provide guidelines on how to properly install a child seat. A forward-facing child seat is used in all examples, but the instructions are the same for rear-facing child seats.

Installing a Child Seat

Installing a Child Seat with LATCH

Your vehicle is equipped with LATCH (Lower Anchors and Tethers for Children) at the outer rear seats.

The lower anchors are located between the seat-back and seat bottom, and are to be used only with a child seat designed for use with LATCH.

The location of each lower anchor is indicated by a small button above the anchor point.

You can find lower anchors in the slits in the seat-backs.

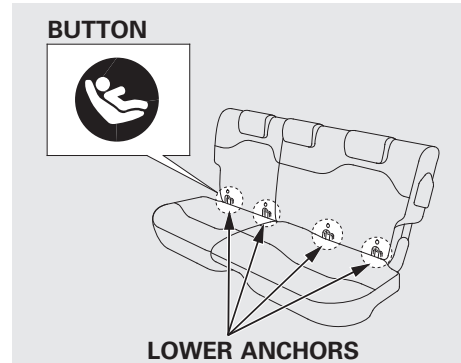

To install a LATCH-compatible child seat:

1. Move the seat belt buckle or tongue away from the lower anchors.
2. Make sure there are no objects near the anchors that could prevent a secure connection between the child seat and the anchors.

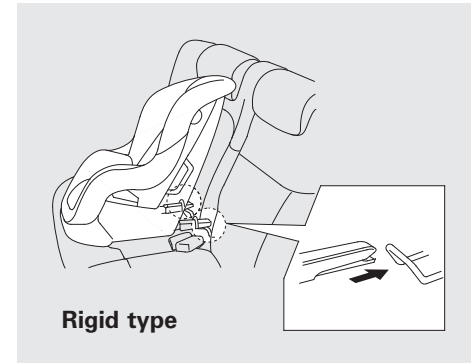

3. Place the child seat on the vehicle seat, then attach the seat to the lower anchors according to the child seat maker's instructions.

Some LATCH-compatible seats have a rigid-type connector as shown above.

CONTINUED

Installing a Child Seat

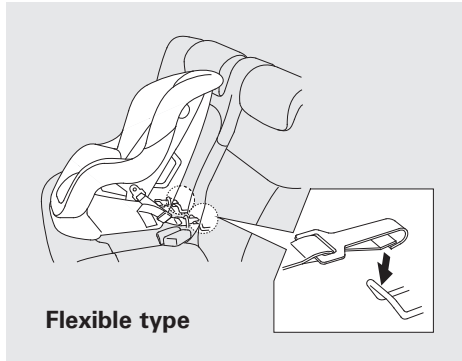

Flexible type

Other LATCH-compatible seats have a flexible-type connector as shown above.

4. Whatever type you have, follow the child seat maker's instructions for adjusting or tightening the fit.

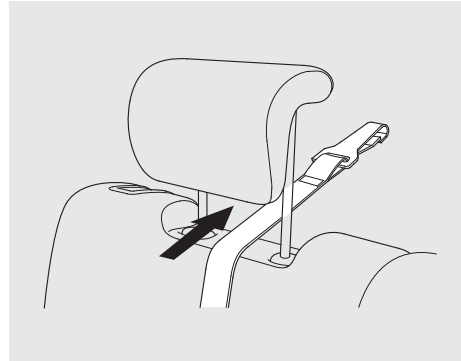

5. Lift the head restraint (see page 94), then route the tether strap through the legs of the head restraint and over the seat-back, making sure the strap is not twisted.

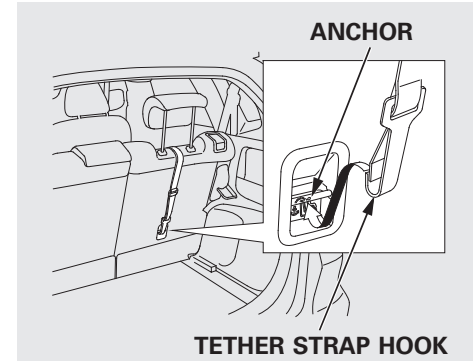

TETHER STRAP HOOK

6. Attach the tether strap hook to the anchor, then tighten the strap as instructed by the child seat maker.

If the tether strap is too long and cannot be tightened firmly, find a route where the strap can be tightened securely.

7. Push and pull the child seat forward and from side-to-side to verify that it is secure.

Installing a Child Seat

Installing a Child Seat with a Lap/Shoulder Belt

When not using the LATCH system, all child seats must be secured to the vehicle with the lap part of a lap/shoulder belt.

In addition, the lap/shoulder belts in all seating positions except the driver's have a lockable retractor that must be activated to secure a child seat.

If you intend to install a child seat in the center seating position of the rear seat, make sure to push down the head restraint to the lowest position, and make sure the detachable seat belt is securely latched (see page 99).



1. With the child seat in the desired seating position, route the belt through the child seat according to the seat maker's instructions, then insert the latch plate into the buckle and remove any slack from the lap portion of the belt.



2. To activate the lockable retractor, slowly pull the shoulder part of the belt all the way out until it stops, then let the belt feed back into the retractor.

3. After the belt has retracted, tug on it. If the belt is locked, you will not be able to pull it out. If you can pull the belt out, it is not locked, and you will need to repeat these steps.

CONTINUED

Installing a Child Seat



4. After confirming that the belt is locked, grab the shoulder part of the belt near the buckle, and pull up to remove any slack from the lap part of the belt. Remember, if the lap part of the belt is not tight, the child seat will not be secure.

To remove slack, it may help to put weight on the child seat, or push on the back of the seat while pulling up on the belt.



5. Push and pull the child seat forward and from side-to-side to verify that it is secure enough to stay upright during normal driving maneuvers. If the child seat is not secure, unlatch the belt, allow it to retract fully, then repeat these steps.

To deactivate the lockable retractor and remove a child seat, unlatch the buckle, unrout the seat belt, and let the belt fully retract.

Installing a Child Seat

Installing a Child Seat with a Tether

A child seat with a tether can be installed in any seating position in the back seat.

Each rear outside seating position has an anchorage point on the seat-back, and the center seating position has an anchorage point in the ceiling near the tailgate.

Since a tether can provide additional security to the lap/shoulder belt installation, we recommend using a tether whenever one is required or available.

Using an Outer Anchor

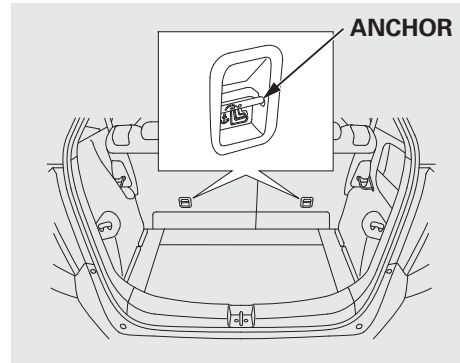

1. After properly securing the child seat (see page 45), lift the head restraint, then route the tether strap over the seat-back and through the head restraint legs.

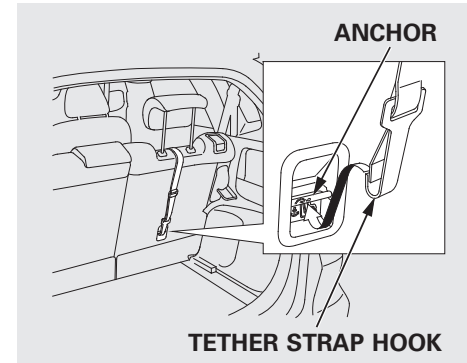

2. Attach the tether strap hook to the anchor, making sure the tether strap is not twisted.
3. Tighten the strap according to the seat maker's instructions.

CONTINUED

Installing a Child Seat

Using the Center Anchor

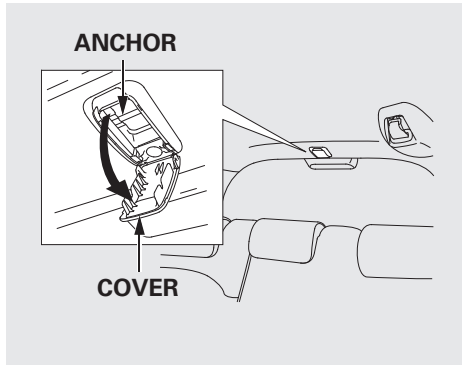

1. Lower the head restraint to its lowest position.
2. After properly securing the child seat (see page 45), open the anchor cover.

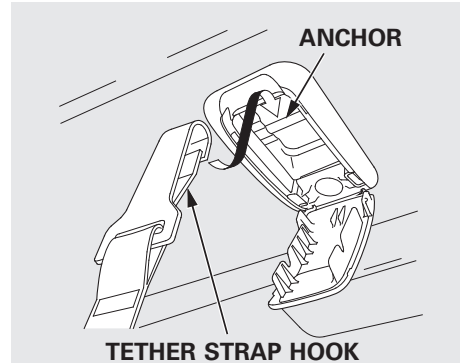

3. Route the tether strap over the head restraint, then attach the tether strap hook to the anchor, making sure the tether strap is not twisted.
4. Tighten the strap according to the seat maker's instructions.

Protecting Larger Children

When a child reaches the recommended weight or height limit for a forward-facing child seat, the child should sit in a back seat on a booster seat and wear the lap/shoulder belt.

The following pages give instructions on how to check proper seat belt fit, what kind of booster seat to use if one is needed, and important precautions for a child who must sit in front.

⚠ WARNING

Allowing a child age 12 or under to sit in front can result in injury or death if the passenger's front airbag inflates.

If a child must ride in front, move the vehicle seat as far back as possible, use a booster seat if needed, have the child sit up properly and wear the seat belt properly.

Checking Seat Belt Fit



To determine if a lap/shoulder belt properly fits a child, have the child put on the seat belt, then ask yourself:

1. Does the child sit all the way back against the seat?
2. Do the child's knees bend comfortably over the edge of the seat?

CONTINUED

Protecting Larger Children

3. Does the shoulder belt cross between the child's neck and arm?
4. Is the lap part of the belt as low as possible, touching the child's thighs?
5. Will the child be able to stay seated like this for the whole trip?

If you answer yes to all these questions, the child is ready to wear the lap/shoulder belt correctly. If you answer no to any question, the child needs to ride on a booster seat.

Using a Booster Seat



A child who has outgrown a forward-facing child seat should ride in a back seat and use a booster seat until the lap/shoulder belt fits them properly without the booster.

Some states, Canadian provinces and territories also require children to use a booster seat until they reach a given age or weight (e.g., 6 years or 60 lbs). Be sure to check current laws in the states, provinces and territories where you intend to drive.

Booster seats can be high-back or low-back. Whichever style you select, make sure the booster seat meets federal safety standards (see page 35) and that you follow the booster seat maker's instructions.

If a child who uses a booster seat must ride in front, move the vehicle seat as far back as possible and be sure the child is wearing the seat belt properly.

A child may continue using a booster seat until the tops of their ears are even with the top of the vehicle's or booster's seat-back. A child of this height should be tall enough to use the lap/shoulder belt without a booster seat.

When Can a Larger Child Sit in Front

The National Highway Traffic Safety Administration and Transport Canada recommend that all children age 12 and under be properly restrained in a back seat.

If the passenger's front airbag inflates in a moderate to severe frontal collision, the airbag can cause serious injuries to a child who is unrestrained, improperly restrained, sitting too close to the airbag, or out of position.

A side airbag also poses risks. If any part of a larger child's body is in the path of a deploying side airbag, the child could receive possibly serious injuries.

Of course, children vary widely. And while age may be one indicator of when a child can safely ride in front, there are other important factors you should consider.

Physical Size

Physically, a child must be large enough for the lap/shoulder belt to properly fit (see pages 14 and 49). If the seat belt does not fit properly, with or without the child sitting on a booster seat, the child should not sit in front.

Maturity

To safely ride in front, a child must be able to follow the rules, including sitting properly, and wearing the seat belt properly throughout a ride.

CONTINUED

Protecting Larger Children

If you decide that a child can safely ride up front, be sure to:

- Carefully read the owner's manual, and make sure you understand all seat belt instructions and all safety information.
- Move the vehicle seat to the rear-most position.
- Have the child sit up straight, back against the seat, and feet on or near the floor.
- Check that the child's seat belt is properly and securely positioned.
- Supervise the child. Even mature children sometimes need to be reminded to fasten the seat belts or sit properly.

Additional Safety Precautions

- ***Do not let a child wear a seat belt across the neck.*** This could result in serious neck injuries during a crash.
- ***Do not let a child put the shoulder part of a seat belt behind the back or under the arm.*** This could cause very serious injuries during a crash. It also increases the chance that the child will slide under the belt in a crash and be injured.
- ***Two children should never use the same seat belt.*** If they do, they could be very seriously injured in a crash.

- ***Do not put any accessories on a seat belt.*** Devices intended to improve a child's comfort or reposition the shoulder part of a seat belt can make the belt less effective and increase the chance of serious injury in a crash.

Carbon Monoxide Hazard

Your vehicle's exhaust contains carbon monoxide gas. Carbon monoxide should not enter the vehicle in normal driving if you maintain your vehicle properly and follow the information on this page.

Have the exhaust system inspected for leaks whenever:

- The vehicle is raised for an oil change.
- You notice a change in the sound of the exhaust.
- The vehicle was in a collision that may have damaged the underside.

WARNING

Carbon monoxide gas is toxic. Breathing it can cause unconsciousness and even kill you.

Avoid any enclosed areas or activities that expose you to carbon monoxide.

High levels of carbon monoxide can collect rapidly in enclosed areas, such as a garage. Do not run the engine with the garage door closed. Even with the door open, run the engine only long enough to move the vehicle out of the garage.

With the tailgate open, airflow can pull exhaust gas into your vehicle's interior and create a hazardous condition. If you must drive with the tailgate open, open all the windows and set the heating and cooling system as shown below.

If you must sit in your parked vehicle with the engine running, even in an unconfined area, adjust the heating and cooling system as follows:

1. Select the fresh air mode.
2. Select the  mode.
3. Turn the fan on high speed.
4. Set the temperature control to a comfortable setting.

Safety Labels

These labels are in the locations shown. They warn you of potential hazards that could cause serious injury or death. Read these labels carefully.

If a label comes off or becomes hard to read (except for the U.S. dashboard label which may be removed by the owner), contact your dealer for a replacement.

SUN VISORS

<p><i>U.S. models</i></p>  <p>AIR BAG WARNING FLIP VISOR OVER</p>	<p><i>Canadian models</i></p> <p>CAUTION TO AVOID SERIOUS INJURY: • FOR MAXIMUM SAFETY PROTECTION IN ALL TYPES OF CRASHES YOU MUST ALWAYS WEAR YOUR SAFETY BELT. • DO NOT INSTALL REARWARD-FACING CHILD SEATS IN ANY FRONT-PASSENGER SEAT POSITION. • DO NOT SET OR LEAN UNNECESSARILY CLOSE TO THE AIR BAG. • DO NOT PLACE ANY OBJECTS OVER THE AIR BAG OR BETWEEN THE AIR BAG AND YOURSELF. • SEE THE OWNER'S MANUAL FOR FURTHER INFORMATION AND EXPLANATIONS.</p>	<p>PRECAUTIONS: POUR ÉVITER DES BLESSURES GRAVES: • POUR PROFITER D'UNE PROTECTION MAXIMALE EN CAS D'UNE COLLISION, PORTÉZ TOUJOURS VOTRE CEINTURE DE SÉCURITÉ. • N'INSTALLEZ JAMAIS UN SIÈGE D'ENFANTS FAISANT FACE À L'ARRIÈRE SUR LE SIÈGE DU PASSAGER AVANT. • NE VOUS APPUYEZ PAS ET NE VOUS ASSOYEZ PAS PRES DU COUSSIN CONDUCTEUR. • NE DÉPOSEZ AUCUN OBJET SUR LE COUSSIN CONDUCTEUR ET VOUS. • LISEZ LE GUIDE D'UTILISATION POUR DE PLUS AMPLES RENSEIGNEMENTS.</p>
<p>▲ WARNING EVEN WITH ADVANCED AIR BAGS</p>  <ul style="list-style-type: none"> ■ Children can be killed or seriously injured by the air bag. ■ The back seat is the safest place for children. ■ Never put a rear-facing child seat in the front. ■ Always use seat belts and child restraints. ■ See owner's manual for more information about air bags. 		

DASHBOARD

U.S. models only

This Vehicle is Equipped with Advanced Air Bags

Even with Advanced Air Bags

Children can be killed or seriously injured by the air bag. The back seat is the safest place for children. Never put a rear-facing child seat in the front. Always use seat belts and child restraints. See owner's manual for more information about air bags.

To be removed by owner only.

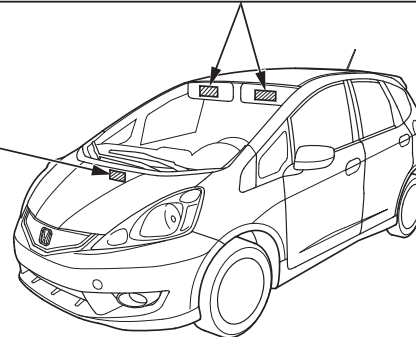

RADIATOR CAP

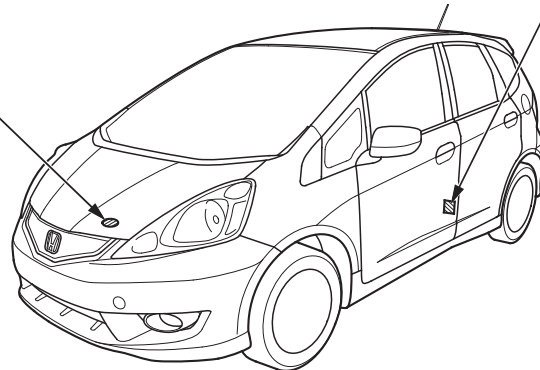

DOORJAMBS

U.S. models

SIDE AIRBAG

- This car is equipped with side airbags in the front seats and side curtain airbags.
- Do not lean against the door.
- See owner's manual for more information.

Canadian models

SIDE AIRBAG

- This car is equipped with side airbags in the front seats and side curtain airbags.
- Do not lean against the door.
- See owner's manual for more information.

COUSSIN GONFLABLE LATÉRAL

- Cette automobile est équipée de coussins gonflables latéraux dans les sièges avant ainsi que de coussins gonflables latéraux de type rideau.
- Ne vous appuyez pas sur la porte.
- Consultez le Manuel du propriétaire pour en savoir plus.

Instruments and Controls

This section gives information about the controls and displays that contribute to the daily operation of your vehicle. All the essential controls are within easy reach.

Control Locations.....	58	Keys and Locks.....	78
Instrument Panel	59	Immobilizer System	79
Instrument Panel Indicators.....	60	Ignition Switch.....	80
Gauges.....	68	Door Locks	81
Trip Meter	69	Power Door Locks	81
Instant Fuel Economy	70	Childproof Door Locks.....	82
Average Fuel Economy	70	Auto Door Locking/ Unlocking	83
Odometer.....	70	Auto Door Locking	83
Fuel Gauge	70	Auto Door Unlocking.....	85
Check Fuel Cap Indicator	70	Tailgate	88
Maintenance Minder	71	Remote Transmitter	90
Controls Near the Steering		Seats	93
Wheel	72	Power Windows	100
Windshield Wipers and		Mirrors	101
Washers	73	Parking Brake.....	102
Windshield Wipers	73	Interior Convenience Items.....	104
Rear Window Wiper and		Lower Glove Box	105
Washer	73	Upper Glove Box.....	105
Turn Signal and Headlights	74	Beverage Holders	106
Headlights	75	Seat Under Box.....	106
Instrument Panel Brightness	76	Accessory Power Socket.....	106
Hazard Warning Button	76	Sun Visor	106
Rear Window Defogger.....	76	Interior Lights.....	107
Steering Wheel Adjustments.....	77		

Control Locations

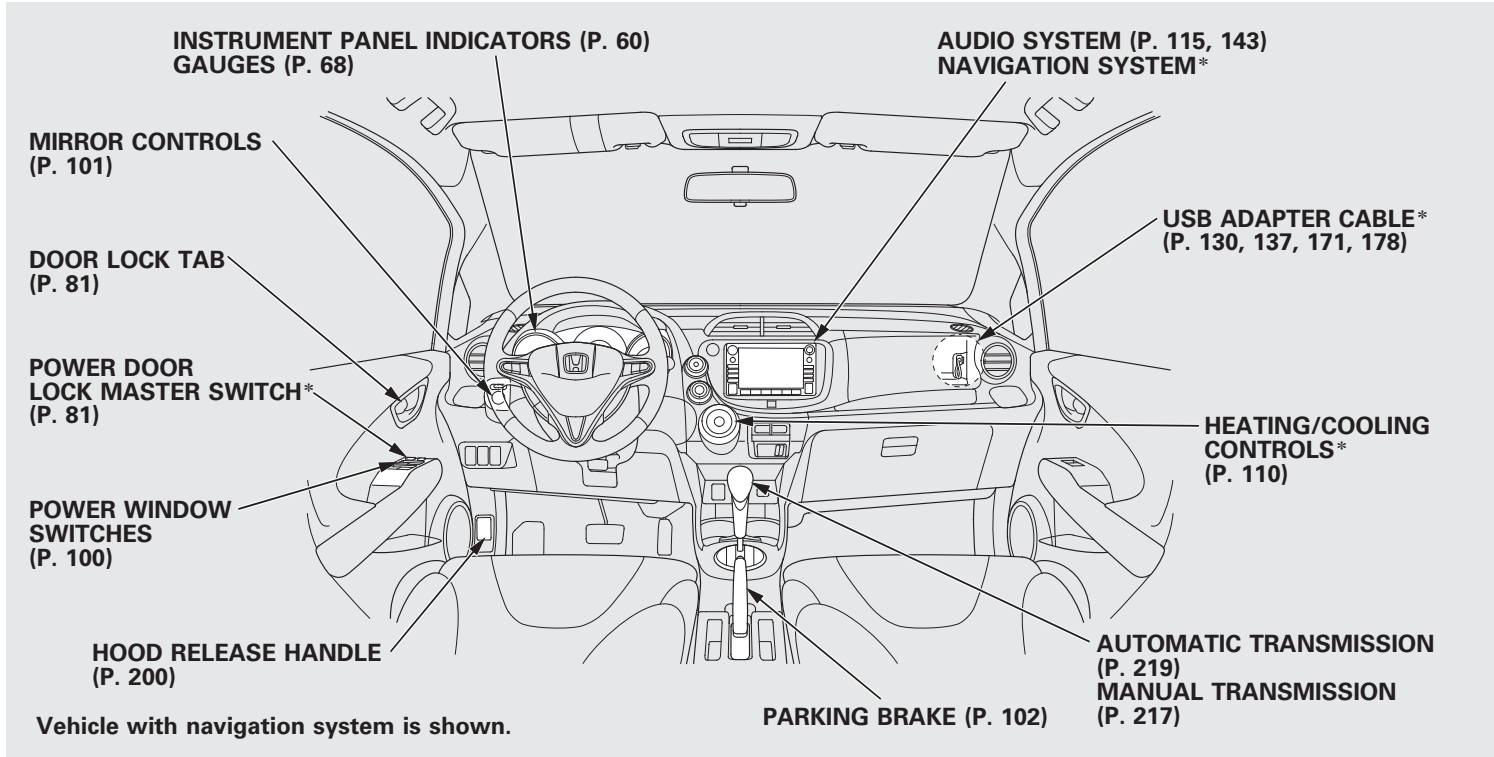

*: If equipped

Instrument Panel

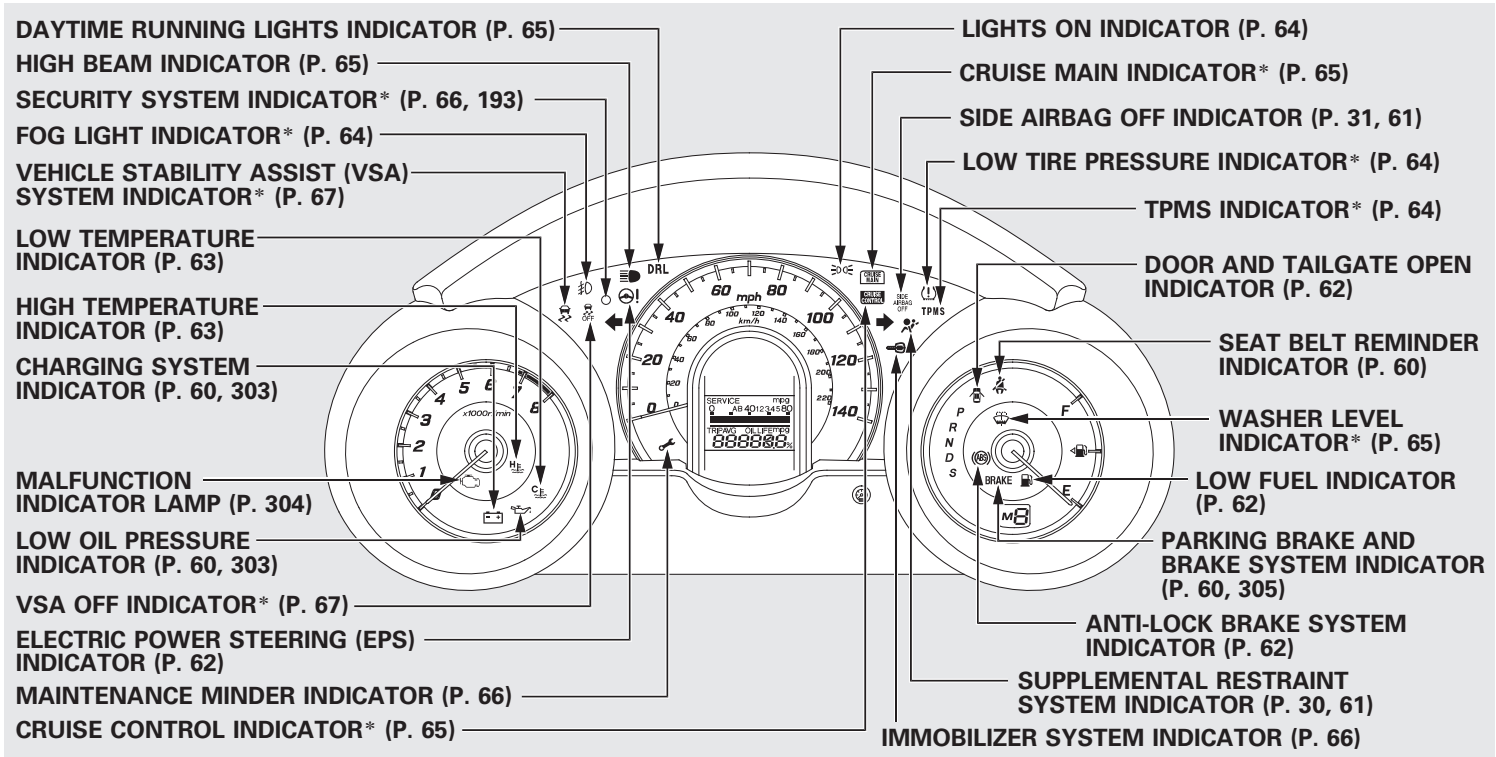

*: If equipped

Instrument Panel Indicators

The instrument panel has many indicators that give you important information about your vehicle.



Malfunction Indicator Lamp

See page 304.



Low Oil Pressure Indicator

The engine can be severely damaged if this indicator flashes or stays on when the engine is running. For more information, see page 303.



Charging System Indicator

If this indicator comes on when the engine is running, the battery is not being charged. For more information, see page 303.

U.S.

BRAKE

Canada



Parking Brake and Brake System Indicator (Red)

This indicator has two functions:

1. It comes on when you turn the ignition switch to the ON (II) position. It is a reminder to check the parking brake. A beeper sounds if you drive with the parking brake not fully released. Driving with the parking brake not fully released can damage the brakes and tires.
2. If it remains on after you have fully released the parking brake while the engine is running, or if it comes on while driving, there could be a problem with the brake system. For more information, see page 305.



Seat Belt Reminder Indicator

This indicator comes on when you turn the ignition switch to the ON (II) position. It reminds you and your passengers to fasten your seat belts. A beeper also sounds if you have not fastened your seat belt.

If you turn the ignition switch to the ON (II) position before fastening your seat belts, the beeper sounds, and the indicator flashes. If you do not fasten your seat belts before the beeper stops, the indicator stops flashing but remains on.

Instrument Panel Indicators

If your front passenger does not fasten their seat belt, the indicator comes on about 6 seconds after the ignition switch is turned to the ON (II) position.

If either of you do not fasten your seat belt while driving, the beeper will sound and the indicator will flash again at regular intervals. For more information, see page 18.



Supplemental Restraint System Indicator

This indicator comes on briefly when you turn the ignition switch to the ON (II) position. If it comes on at any other time, it indicates a potential problem with your front airbags. This indicator will also alert you to a potential problem with your side airbags, passenger's side airbag cutoff system, side curtain airbags, automatic seat belt tensioners, driver's seat position sensor, or the front passenger's weight sensors. For more information, see page 30.

U.S.



Canada



Side Airbag Off Indicator

This indicator comes on briefly when you turn the ignition switch to the ON (II) position. If it comes on at any other time, it indicates that the passenger's side airbag has automatically shut off. For more information, see page 31.

CONTINUED

Instrument Panel Indicators



Anti-lock Brake System (ABS) Indicator

This indicator normally comes on for a few seconds when you turn the ignition switch to the ON (II) position, and when the ignition switch is turned to the START (III) position. If it comes on at any other time, there is a problem with the ABS. If this happens, have your vehicle checked at a dealer. With this indicator on, your vehicle still has normal braking ability but no anti-lock function. For more information, see page 231.



Electric Power Steering (EPS) Indicator

This indicator normally comes on when you turn the ignition switch to the ON (II) position and goes off after the engine starts. If it comes on at any other time, there is a problem in the electric power steering system. If this happens, stop the vehicle in a safe place and turn off the engine. Reset the system by restarting the engine. The indicator will not turn off immediately. If it does not go off after driving a short distance, or comes back on again while driving, take the vehicle to your dealer to have it checked. With the indicator on, the EPS may be turned off, making the vehicle harder to steer.

If you turn the steering wheel to the full left or right position repeatedly while stopping or driving at very low speed, you may feel slightly harder steering in order to prevent damage to the steering box caused by overheating.



Low Fuel Indicator

This indicator comes on as a reminder that you must refuel soon. When the indicator comes on, there is about 1.64 US gal (6.2 L) of fuel remaining in the tank before the needle reaches E. There is a small reserve of fuel remaining in the tank when the needle does reach E.



Door and Tailgate Open Indicator

This indicator comes on if any door or the tailgate is not closed tightly.

Instrument Panel Indicators



High Temperature Indicator

This indicator monitors the temperature of the engine coolant. It normally comes on when you turn the ignition switch to the ON (II) position and goes off after a few seconds. In normal driving conditions, this indicator should not blink or stay on. In severe driving conditions, such as very hot weather or a long period of uphill driving, this indicator may blink. This means the engine coolant temperature is high. If the indicator begins to blink while you are driving, be sure to slow down to prevent overheating. If the indicator stays on, pull safely to the side of the road and turn off the engine. See page 301 for instructions and precautions on checking the engine's cooling system.

Do not drive the vehicle while the indicator is on or the engine may be damaged.



Low Temperature Indicator

This indicator monitors the temperature of the engine coolant. If there is no problem, this indicator comes on when the engine is cold. If it comes on when the engine is warm (normal operating temperature), have the vehicle inspected by your dealer as soon as possible.



Turn Signal and Hazard Warning Indicators

The left or right turn signal indicator blinks when you signal a lane change or turn. If an indicator does not blink or blinks rapidly, it usually means one of the turn signal bulbs is burned out (see page 264). Replace the bulb as soon as possible, since other drivers cannot see that you are signaling.

When you press the hazard warning button, both turn signal indicators and all turn signals on the outside of the vehicle flash.

CONTINUED

Instrument Panel Indicators



Low Tire Pressure Indicator

U.S. models only

This indicator normally comes on for a few seconds when you turn the ignition switch to the ON (II) position. If it comes on while driving, it indicates that one or more of your vehicle's tires are significantly low on pressure.

If this happens, pull to the side of the road when it is safe, check which tire has lost the pressure, and determine the cause. If it is because of a flat tire, replace the flat tire with the compact spare (see page 284), and have the flat tire repaired as soon as possible. If two or more tires are underinflated, call a professional towing service (see page 311). For more information, see page 235.



Tire Pressure Monitoring System (TPMS) Indicator

U.S. models only

This indicator normally comes on for a few seconds when you turn the ignition switch to the ON (II) position.

If this indicator comes on and stays on at any other time, or if it does not come on when you turn the ignition switch to the ON (II) position, there is a problem with the TPMS. With this indicator on, the low tire pressure indicator will not come on when a tire loses pressure. Take the vehicle to your dealer to have the system checked.

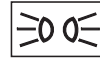

Lights On Indicator

This indicator reminds you that the exterior lights are on. It comes on when the light switch is in either the $\Rightarrow \text{O} \Leftarrow$ or $\Rightarrow \text{D} \Leftarrow$ position. If you turn the ignition switch to the ACCESSORY (I) or LOCK (0) position without turning off the light switch, this indicator will stay on. A reminder chime will also sound when you open the driver's door.

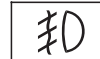

Fog Light Indicator

On Sport model

This indicator comes on when you turn on the fog lights. For more information, see page 75.



High Beam Indicator

This indicator comes on with the high beam headlights. For more information, see page 75.

This indicator comes on with reduced brightness when the daytime running lights (DRL) are on (see page 75).



Daytime Running Lights Indicator

If this indicator comes on when the ignition switch is turned to the ON (II) position and the parking brake is released, it means there is a problem in the circuit. Have your vehicle checked by your dealer.



Cruise Main Indicator

On Sport model and Canadian LX model
This indicator comes on when you turn on the cruise control system by pressing the CRUISE button (see page 194).



Cruise Control Indicator

On Sport model and Canadian LX model
This indicator comes on when you set the cruise control. See page 194 for information on operating the cruise control.



Washer Level Indicator

Canadian models only
This indicator comes on when the washer fluid level is low. Add washer fluid when you see this indicator come on (see page 258).

CONTINUED

Instrument Panel Indicators



Maintenance Minder Indicator

This indicator comes on for a few seconds when you turn the ignition switch to the ON (II) position. It reminds you that it is time to take your vehicle in for scheduled maintenance. The maintenance main items and sub items will be displayed in the information display. See page 245 for more information on the maintenance minder.

This indicator goes off when your dealer resets it after completing the required maintenance service.



Immobilizer System Indicator

This indicator comes on briefly when you turn the ignition switch to the ON (II) position. It will go off if you have inserted a properly coded ignition key. If it is not a properly coded key, the indicator will blink, and the engine's fuel system will be disabled (see page 79).

Security System Indicator

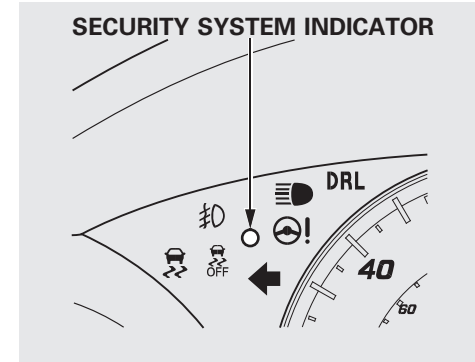

On Sport model

This indicator comes on when the security system is set. See page 193 for more information on the security system.



Vehicle Stability Assist (VSA) System Indicator

If equipped

This indicator normally comes on for a few seconds when you turn the ignition switch to the ON (II) position and when the ignition switch is turned to the START (III) position.

It flashes when VSA is active (see page 233).

If it comes on and stays on at any other time, or if it does not come on when you turn the ignition switch to the ON (II) position, there is a problem with the VSA system. Take your vehicle to a dealer to have it checked. Without VSA, your vehicle still has normal driving ability, but will not have VSA traction and stability enhancement. See page 233 for more information on the VSA system.



VSA Off Indicator

If equipped

It comes on as a reminder that you have turned off the vehicle stability assist (VSA) system.

This indicator normally comes on for a few seconds when you turn the ignition switch to the ON (II) position and when the ignition switch is turned to the START (III) position. See page 233 for more information on the VSA system.

Gauges

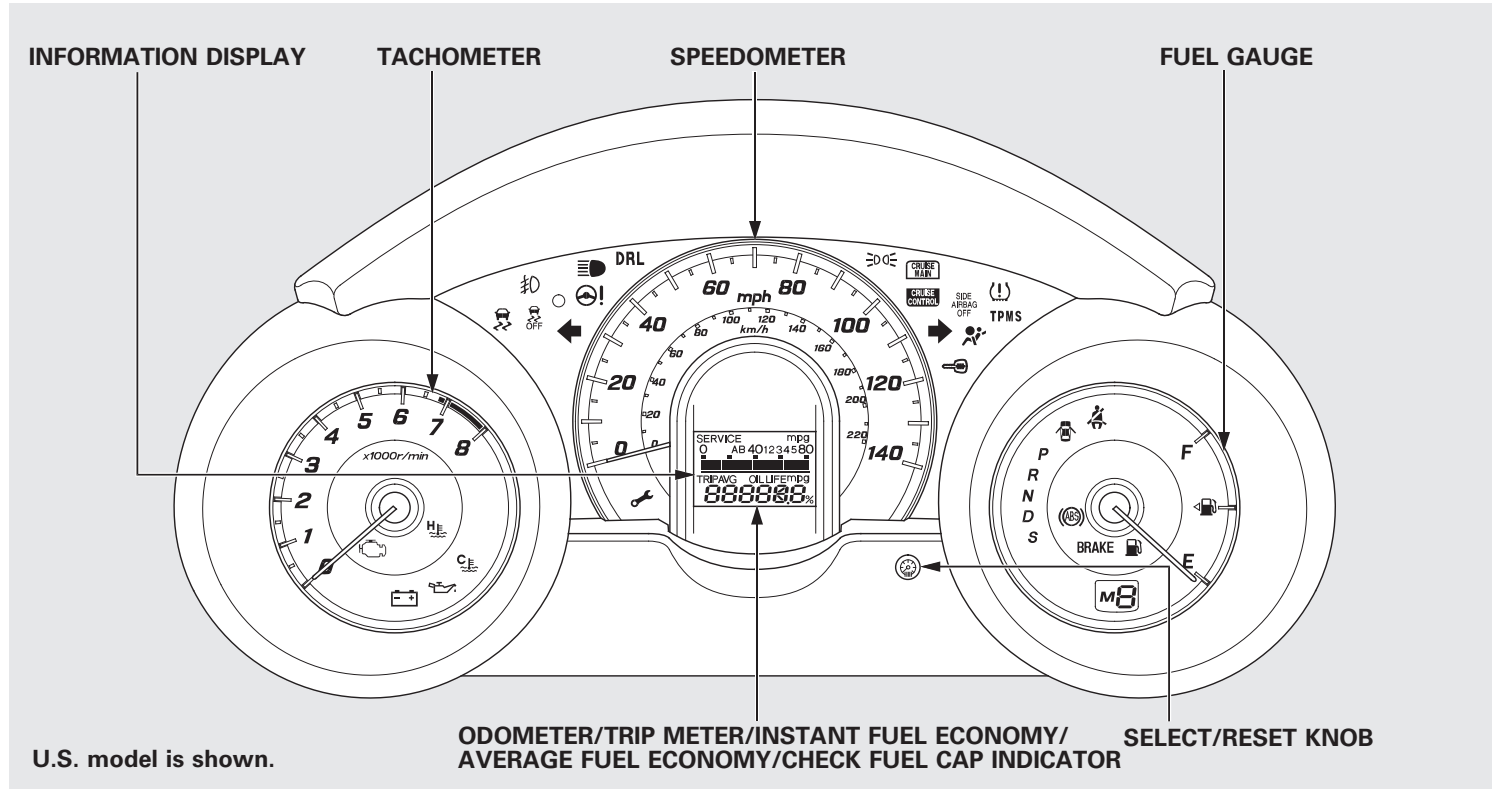

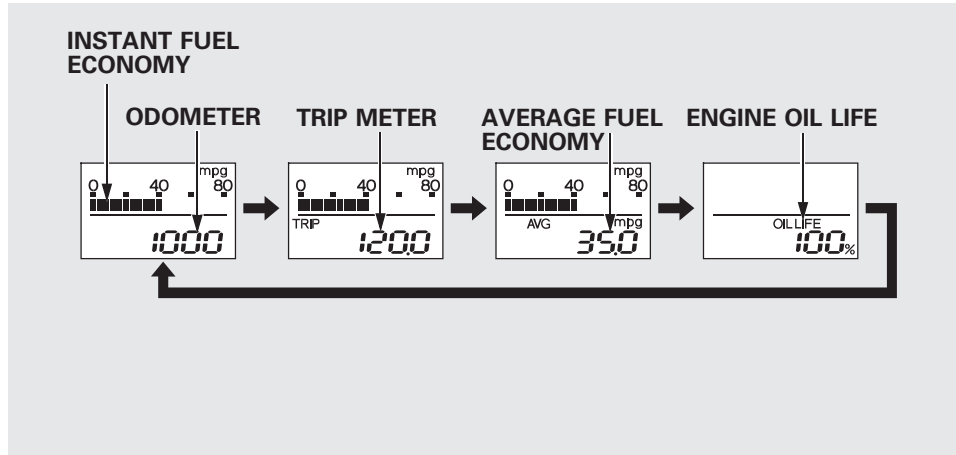

The information display consists of two segments. The upper segment displays instant fuel economy, maintenance item code(s), and the lower segment displays the trip meter, odometer, average fuel economy, and engine oil life.

To switch the display, press and release the select/reset knob repeatedly. When you turn the ignition switch to the ON (II) position the last selection is displayed.

Trip Meter

This meter shows the number of miles (U.S.) or kilometers (Canada) driven since you last reset it.

To reset a trip meter, display it, and then press and hold the select/reset knob until the number resets to "0.0".

When you reset the trip meter, average fuel mileage is reset simultaneously.

Gauges

Instant Fuel Economy

This shows your instant fuel economy in mpg (U.S.) or l/100 km (Canada).

Average Fuel Economy

This shows your vehicle's average fuel economy in mpg (U.S.) or l/100 km (Canada) since you last reset the trip meter.

When you reset a trip meter, the average fuel economy for that trip meter also resets.

Odometer

The odometer shows the total distance your vehicle has been driven. It measures miles in U.S. models and kilometers in Canadian models. It is illegal under U.S. federal law and Canadian provincial/territorial regulations to disconnect, reset, or alter the odometer with the intent to change the number of miles or kilometers indicated.

Fuel Gauge

This shows how much fuel you have. It may show slightly more or less than the actual amount. The needle returns to the bottom after you turn off the ignition.

NOTICE

Avoid driving with an extremely low fuel level. Running out of fuel could cause the engine to misfire, damaging the catalytic converter.

Check Fuel Cap Indicator

If the fuel fill cap is loose or missing, a “CHECK FUEL CAP” message appears on the information display after you start the engine. The message changes from CHECK, to FUEL, to CAP repeatedly.

Turn the engine off and confirm the fuel fill cap is installed. If it is, loosen the cap, then retighten it until it clicks at least once. You can cycle the message off of the display by pressing the select/reset knob repeatedly, but this message will be displayed each time the engine is started. It will take several days of normal driving for the vehicle to turn the warning off.

If the system still detects a loose or missing fuel fill cap, the malfunction indicator lamp (MIL) comes on. Turn the engine off, and check or retighten the fuel fill cap until it clicks at least once. The MIL goes out after several days of normal driving once the cap is tightened or replaced. If it does not go out, have your dealer inspect the vehicle. For more information, see page 304.

Maintenance Minder

The information display in the instrument panel shows you the engine oil life and maintenance service items when the ignition switch is in the ON (II) position. This information helps to keep you aware of the periodic maintenance your vehicle needs for continued trouble-free driving. Refer to page 245 for more information.

Controls Near the Steering Wheel

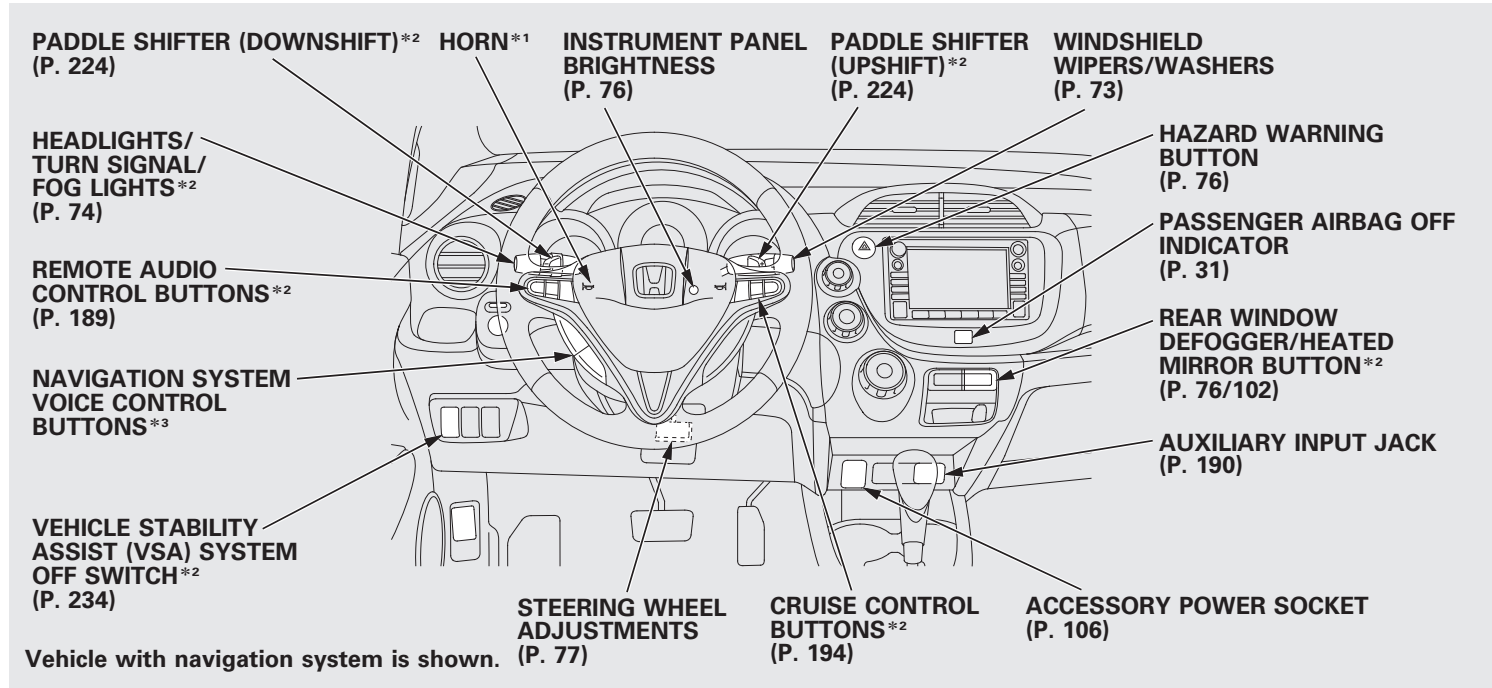

*1: To use the horn, press the center pad of the steering wheel.

*2: If equipped.

*3: Only on vehicles equipped with navigation system. Refer to the navigation system manual.

Windshield Wipers and Washers

Windshield Wipers

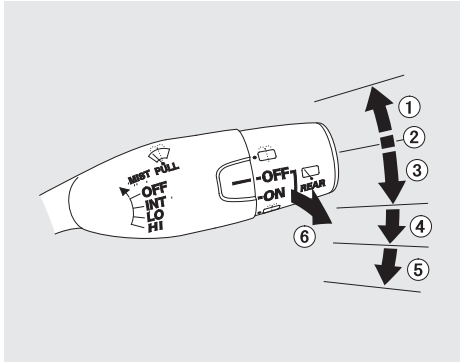

1. MIST
2. OFF
3. INT – Intermittent
4. LO – Low speed
5. HI – High speed
6. Windshield washers

Push the right lever up or down to select a position.

MIST – The wipers run at high speed until you release the lever.

OFF – The wipers are not activated.

INT – The wipers operate every few seconds.

LO – The wipers run at low speed.

HI – The wipers run at high speed.

Windshield Washers – Pull the wiper control lever toward you, and hold it. The washers spray until you release the lever. The wipers run at low speed, then complete one more sweep after you release the lever.

Rear Window Wiper and Washer

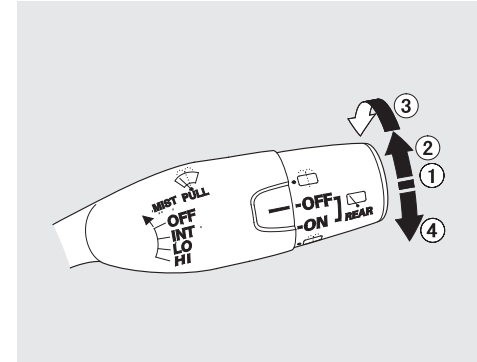

1. OFF
When you turn the wiper switch to the “OFF” position, the wiper will return to its parked position.
2. Rotate the switch clockwise to turn the rear window wiper ON.
3. Hold past ON to turn the rear window wiper on and to spray the rear window washer.

CONTINUED

Windshield Wipers and Washers, Turn Signal and Headlights

4. Hold past OFF to turn the rear window wiper on and to spray the rear window washer. The rear window wiper makes one more sweep after you release the switch.

When you shift the transmission to the reverse position with the front windshield wiper activated, the rear wiper operates automatically even if the rear wiper switch is off.

The rear window washer uses the same fluid reservoir as the windshield washer.

Turn Signal and Headlights

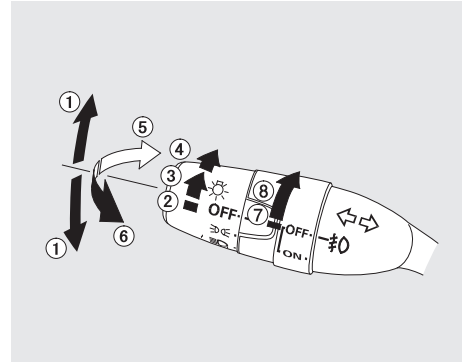

1. Turn signal
2. Off
3. Parking and interior lights
4. Headlights
5. High beams
6. Flash high beams

On Sport model

7. Fog lights off
8. Fog lights on

Turn Signal – Push down on the left lever to signal a left turn and up to signal a right turn. To signal a lane change, push lightly on the lever and hold it. The lever will return to the center when you release it or complete a turn.

Headlights – Turning the switch to the “☰” position turns on the parking lights, taillights, instrument panel lights, side-marker lights, and rear license plate lights.

Turning the switch to the “☷” position turns on the headlights.

When the light switch is in the “☰” or “☷” position, the lights on indicator comes on as a reminder. This indicator stays on if you leave the light switch on and turn the ignition switch to the ACCESSORY (I) or the LOCK (0) position.

If you leave the lights on with the key removed from the ignition switch, you will hear a reminder chime when you open the driver's door.

High Beams – Push the lever forward and the high beam indicator will come on (see page 65). Pull it back to return to low beams.

To flash the high beams, pull the lever back lightly, then release it. The high beams will stay on as long as you hold the lever back.

Fog Lights

On Sport model

Turn the fog lights on and off by turning the switch next to the headlight switch.

You can use the fog lights only when the headlights are on low beam. They will go off when the headlights are turned off.

Daytime Running Lights

With the headlight switch off or in the ☰ position, the high beam headlights and the high beam indicator come on with reduced brightness when you turn the ignition switch to the ON (II) position and release the parking brake. They remain on until you turn the ignition switch off, even if you set the parking brake.

The headlights revert to normal operation when you turn them on with the switch.

Instrument Panel Brightness, Hazard Warning Button, Rear Window Defogger

Instrument Panel Brightness

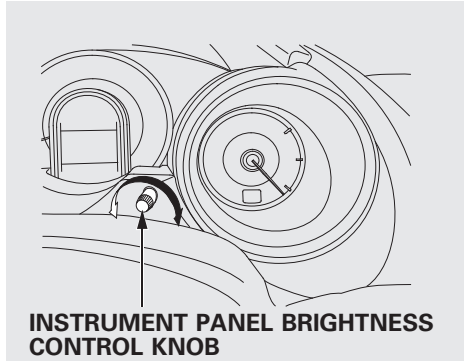

You can change the instrument panel brightness only when the ignition switch is in the ON (II) position and the light switch is on.

Turn the knob on the lower part of the instrument panel to adjust the brightness.

You will hear a beep when maximum or minimum brightness is reached. You will also hear a beep when the maximum level is canceled by turning the knob a click to the left.

Hazard Warning Button

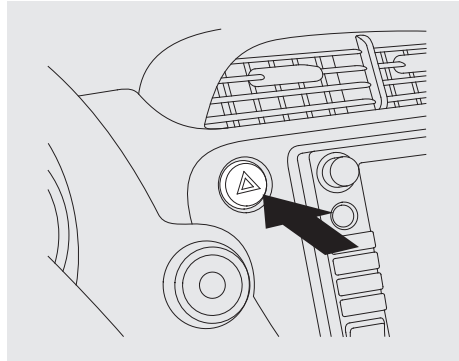

Push the button to turn on the hazard warning lights (four-way flashers). This causes all four outside turn signals and both turn indicators in the instrument panel to flash. Use the hazard warning lights if you need to park in a dangerous area near heavy traffic, or if your vehicle is disabled.

Rear Window Defogger

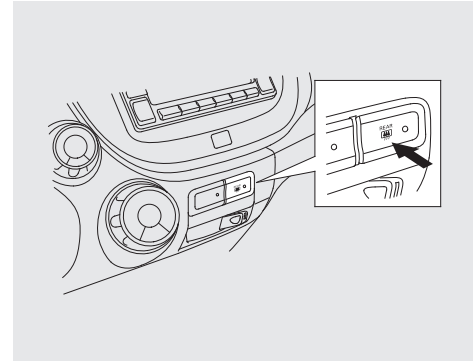

The rear window defogger will clear fog, frost, and thin ice from the window. Push the defogger button to turn it on and off. The indicator in the button comes on to show the defogger is on. You must manually shut off the rear window defogger when it is no longer needed.

Rear Window Defogger, Steering Wheel Adjustments

Make sure the rear window is clear and you have good visibility before starting to drive.

The defogger wires on the inside of the rear window can be accidentally damaged. When cleaning the glass, always wipe side-to-side.

If equipped

Pushing this button also turns the mirror heaters on or off. For more information, see page 102.

Steering Wheel Adjustments

Make any steering wheel adjustment before you start driving.

⚠ WARNING

Adjusting the steering wheel position while driving may cause you to lose control of the vehicle and be seriously injured in a crash.

Adjust the steering wheel only when the vehicle is stopped.

1. Pull the lever under the steering column toward you until it stops.
2. Move the steering wheel up or down, and in or out, so it points toward your chest, not toward your face. Make sure you can see the instrument panel gauges and indicators.

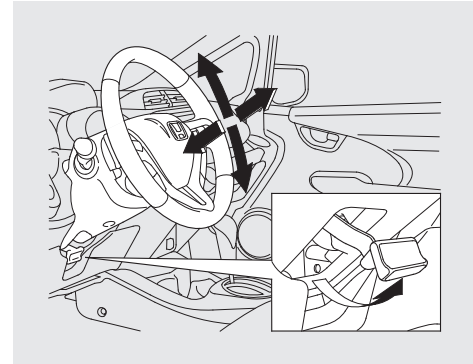

3. Push the lever forward fully to lock the steering wheel in position.
4. Make sure you have securely locked the steering wheel in place by trying to move it up, down, in, and out.

Keys and Locks

On Sport model and Canadian LX model

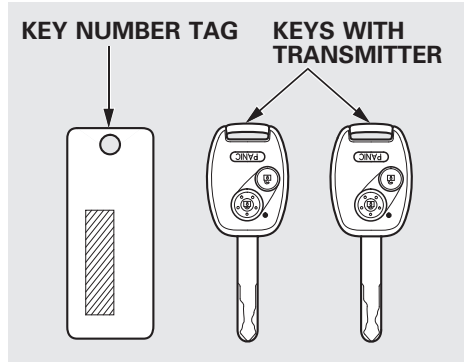

Your vehicle comes with the two ignition keys.

All models except Sport model and Canadian LX model

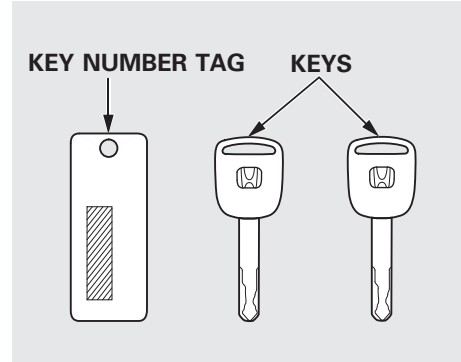

You should have received a key number tag with your keys. You will need this key number if you ever have to get a lost key replaced. Use only Honda-approved key blanks.

These keys contain electronic circuits that are activated by the immobilizer system. They will not work to start the engine if the circuits are damaged.

- Protect the keys from direct sunlight, high temperature, and high humidity.
- Do not drop the keys or set heavy objects on them.
- Keep the keys away from liquids. If they get wet, dry them immediately with a soft cloth.

All models except Sport model and Canadian LX model

The keys do not contain batteries. Do not try to take them apart.

The immobilizer system protects your vehicle from theft. If an improperly coded key (or other device) is used, the engine's fuel system is disabled.

When you turn the ignition switch to the ON (II) position, the immobilizer system indicator should come on briefly, then go off. If the indicator starts to blink, it means the system does not recognize the coding of the key. Turn the ignition switch to the LOCK (0) position, remove the key, reinsert it, and turn the ignition switch to the ON (II) position again.

The system may not recognize your key's coding if another immobilizer key or other metal object (i.e. key chain) is near the ignition switch when you insert the key.

If the system repeatedly does not recognize the coding of your key, contact your dealer.

Do not attempt to alter this system or add other devices to it. Electrical problems could result that may make your vehicle inoperable.

If you have lost your key and cannot start the engine, contact your dealer.

NOTICE

Always take the ignition key with you whenever you leave the vehicle alone.

As required by the FCC:

This device complies with Part 15 of the FCC rules. Operation is subject to the following two conditions: (1) This device may not cause harmful interference, and (2) this device must accept any interference received, including interference that may cause undesired operation.

Changes or modifications not expressly approved by the party responsible for compliance could void the user's authority to operate the equipment.

This device complies with Industry Canada Standard RSS-210. Operation is subject to the following two conditions: (1) this device may not cause interference, and (2) this device must accept any interference that may cause undesired operation of the device.

Ignition Switch

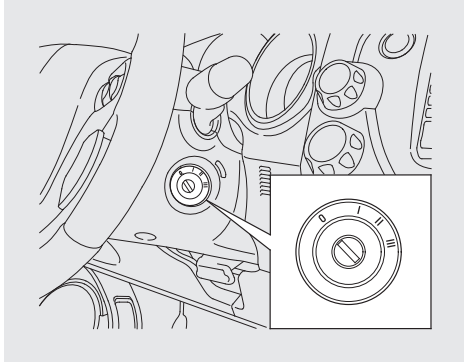

The ignition switch has four positions: LOCK (0), ACCESSORY (I), ON (II), and START (III).

LOCK (0) – You can insert or remove the key only in this position. To turn the key, push it in slightly. If your vehicle has an automatic transmission, the shift lever must also be in Park.

If the front wheels are turned, the anti-theft lock may make it difficult to turn the key. Firmly turn the steering wheel to the left or right as you turn the key.

ACCESSORY (I) – You can operate the audio system and the accessory power socket in this position.

ON (II) – This is the normal key position when driving. Several of the indicators on the instrument panel come on as a test when you turn the ignition switch from the ACCESSORY (I) to the ON (II) position.

START (III) – Use this position only to start the engine. The switch returns to the ON (II) position when you let go of the key.

You will hear a reminder beeper if you leave the key in the LOCK (0) or the ACCESSORY (I) position and open the driver's door. Remove the key to turn off the beeper.

If your vehicle has an automatic transmission, the shift lever must be in Park before you can remove the key from the ignition switch.

⚠ WARNING

Removing the key from the ignition switch while driving locks the steering. This can cause you to lose control of the vehicle.

Remove the key from the ignition switch only when parked.

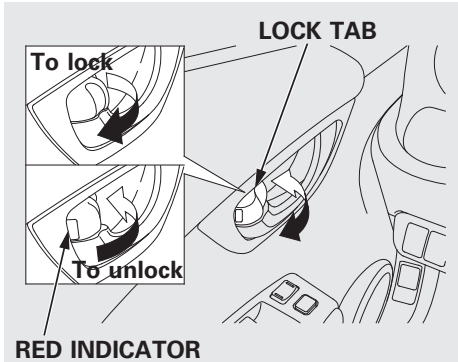

Each door has a lock tab next to the inside door handle. Pull the lock tab to lock the door, and push it forward to unlock the door.

On Canadian DX and DX-A models
To lock the passenger's door when getting out of the vehicle, pull the lock tab and close the door. To lock the driver's door, pull and hold the outside door handle, then pull the lock tab. Release the handle, then close the door.

When the door is unlocked, you can see the red indicator on the lock tab above the inner door handle.

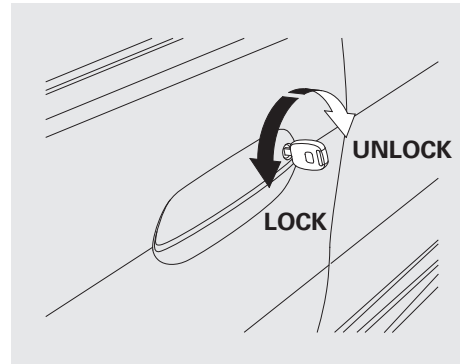

All models except Sport model and Canadian LX model
Each front door can be locked or unlocked with the ignition key.

Power Door Locks

MASTER DOOR LOCK SWITCH

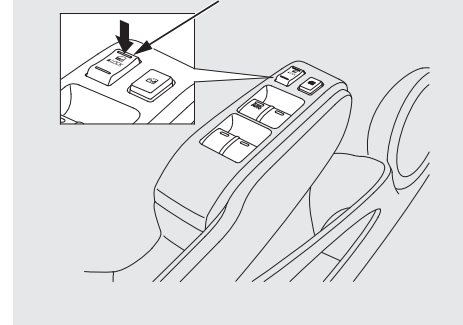

All models except Canadian DX and DX-A models

To lock the doors and the tailgate, push the top of the master door lock switch on the driver's door, pull the lock tab rearward on the driver's door, or use the key in the outside door lock on the driver's door.

Pushing the bottom of the master door lock switch unlocks all doors and the tailgate.

CONTINUED

Door Locks

The lock tab on each passenger's door locks and unlocks only that door. Pushing forward the lock tab on the driver's door unlocks only that door. To unlock only the driver's door from the outside, turn the key and release it. If you turn it again, the remaining doors and the tailgate unlock.

To lock a passenger's door when getting out of the vehicle, pull the lock tab rearward and close the door. To lock the driver's door, remove key from ignition switch and pull the lock tab rearward or push the top of the master door lock switch, then close the door.

Lockout Prevention

If you forget and leave the key in the ignition switch, lockout prevention will not allow you to lock the driver's door. With any door open and the key in the ignition switch, locking with master door lock switch is disabled. If the driver's door is closed, the lock tab on the driver's door is not disabled. Pulling the driver's lock tab rearward will lock all doors. If you try to lock an open driver's door by pulling the lock tab rearward, the driver's door lock tab pops out and unlocks the driver's door.

Childproof Door Locks

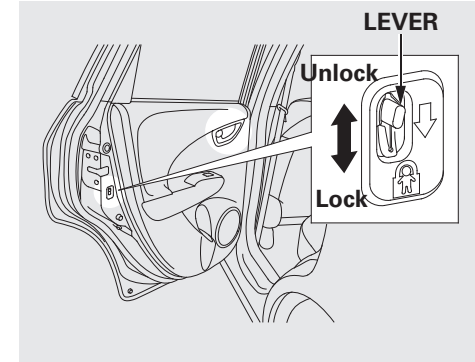

The childproof door locks are designed to prevent children seated in the rear from accidentally opening the rear doors. Each rear door has a lock lever near the edge. With the lever in the LOCK position (lever is down), the door cannot be opened from the inside regardless of the position of the lock tab. To open the door, pull the lock tab forward and use the outside door handle.

Auto Door Locking/Unlocking

On all models except Canadian DX and DX-A

Your vehicle has customizable settings for the doors and tailgate to automatically lock and unlock. There are default settings for each of these features. You can turn off or change the settings for these features as described on the following pages.

When you customize the setting, make sure your vehicle is parked safely, the engine is off, and apply the parking brake. Make all settings before you start driving.

Auto Door Locking

The auto door locking feature has three possible settings:

- The auto door locking is deactivated all the time.
- All doors and tailgate lock whenever you move the shift lever out of the Park (P) position (A/T vehicles).
- All doors and tailgate lock when the vehicle speed reaches 9 mph (15 km/h).
This is the default setting.

To turn off the Auto Door Lock modes:

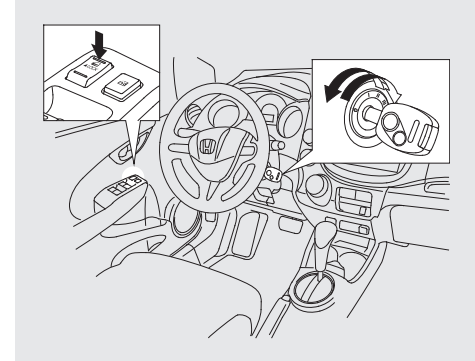

1. Make sure the shift lever is in the Park (P) position (A/T vehicles).
2. Turn the ignition switch to the ON (II) position, and open the driver's door.

CONTINUED

Door Locks

3. Push and hold the front of the master door lock switch on the driver's door until you hear a click (after about 5 seconds).
4. Release the switch, and within 5 seconds, turn the ignition switch to the LOCK (0) position.

To program the Park Lock mode:
Locks all doors and tailgate when the shift lever is moved out of the Park (P) position (A/T vehicles only).

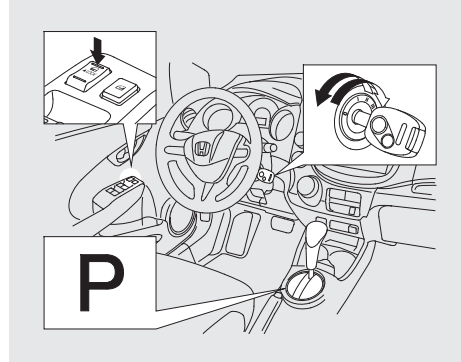

1. Make sure the shift lever is in the Park (P) position.
2. Turn the ignition switch to the ON (II) position, and make sure to close the driver's door.

3. Push and hold the front of the master door lock switch on the driver's door. You will hear a click. Keep holding the switch until you hear another click (after about 5 seconds).
4. Release the switch, and within 5 seconds, turn the ignition switch to the LOCK (0) position.

To program the Drive Lock mode:
Locks all doors and tailgate when the vehicle's speed reaches about 9 mph (15 km/h).

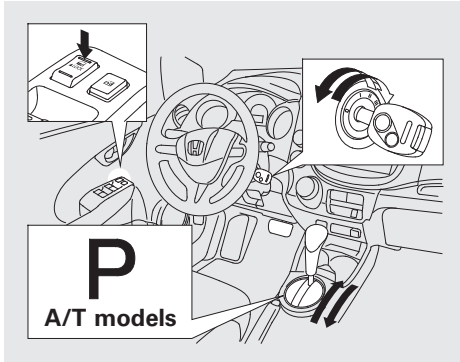

1. Make sure the shift lever is in the Park (P) position (A/T vehicles).
2. Turn the ignition switch to the ON (II) position, and make sure to close the driver's door.

3. *On A/T vehicles*, push and hold the brake pedal, and move the shift lever out of the Park (P) position.
4. Push and hold the front of the master door lock switch on the driver's door. You will hear a click. Keep holding the switch until you hear another click (after about 5 seconds).
5. Release the switch, and within 5 seconds, turn the ignition switch to the ACCESSORY (I) position. *On A/T vehicles*, move the shift lever to the Park (P) position.
6. Turn the ignition switch to the LOCK (0) position.

Auto Door Unlocking

The auto door unlocking feature has five possible settings:

- The auto door unlocking is deactivated all the time.
- *On A/T vehicles*, the driver's door unlocks when you move the shift lever to the Park (P) position with the brake pedal depressed. This is the default setting.
- All doors and tailgate unlock when you move the shift lever to the Park (P) position (A/T vehicles) with the brake pedal depressed.
- The driver's door unlocks whenever you turn the ignition switch to the ACCESSORY (I) position. This is the default setting on M/T vehicles.
- All doors and tailgate unlock whenever you turn the ignition switch to the ACCESSORY (I) position.

CONTINUED

Door Locks

To turn off the Auto Door Unlock modes:

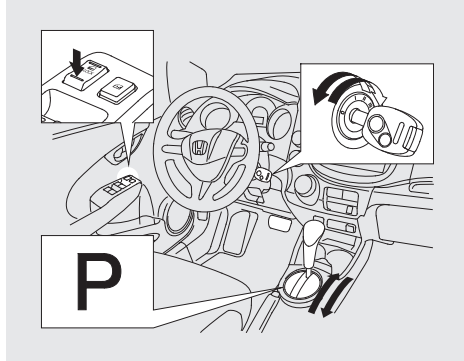

1. Make sure the shift lever is in the Park (P) position (A/T vehicles).
2. Turn the ignition switch to the ON (II) position, and open the driver's door.
3. Push and hold the rear of the master door lock switch on the driver's door. You will hear a click, and after about 5 seconds, you will hear another click.

4. Release the switch, and within 5 seconds, turn the ignition switch to the LOCK (0) position.

To program the Park Unlock mode:

Unlocks the driver's door or all doors and tailgate when the shift lever is moved into the Park (P) position with the brake pedal depressed (A/T vehicles only).

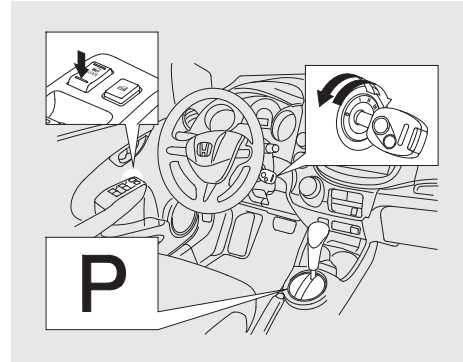

1. Make sure the shift lever is in the Park (P) position.

2. Turn the ignition switch to the ON (II) position, and make sure to close the driver's door.

3. Push and hold the rear of the master door lock switch on the driver's door. You will hear a click. Continue to hold the switch:

- Until you hear another click (after about 5 seconds) to activate *driver's door unlock feature*.
- Or, until you hear two more clicks (after about 10 seconds) to activate *all doors and tailgate unlock feature*.

4. Release the switch, and within 5 seconds, turn the ignition switch to the LOCK (0) position.

To program the Ignition Switch Unlock mode:

Unlocks the driver's door or all doors and tailgate when the ignition switch is moved out of the ON (II) position.

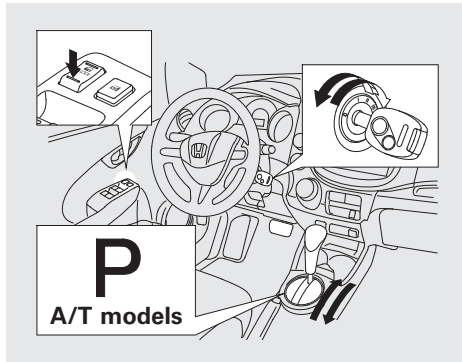

1. Make sure the shift lever is in the Park (P) position (A/T vehicles).
2. Turn the ignition switch to the ON (II) position, and make sure to close the driver's door.
3. *On A/T vehicles*, push and hold the brake pedal, then move the shift lever out of the Park (P) position.
4. Push and hold the rear of the master door lock switch on the driver's door. You will hear a click. Continue to hold the switch:
 - Until you hear another click (after about 5 seconds) to activate *driver's door unlock feature*.
 - Or, until you hear two more clicks (after about 10 seconds) to activate *all doors and tailgate unlock feature*.
5. Release the switch, and within 5 seconds, turn the ignition switch to the ACCESSORY (I) position. *On A/T vehicles*, move the shift lever to the Park (P) position.
6. Turn the ignition switch to the LOCK (0) position.

Even if your vehicle's battery is removed or goes dead, the system keeps the auto door lock/unlock setting which you selected.

Tailgate

All models except Canadian DX and DX-A models

The tailgate will lock or unlock when you lock or unlock the driver's door by using the key, the lock tab on the driver's door, the master door lock switch or the remote transmitter (if equipped).

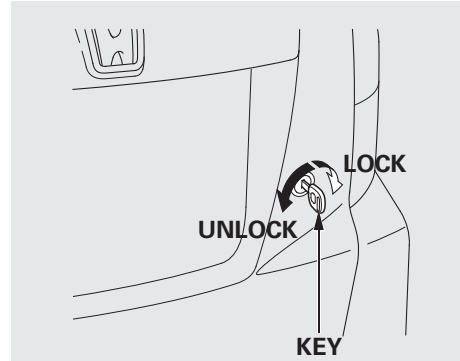

All models except Sport model and Canadian LX model
You can lock or unlock the tailgate with the key.

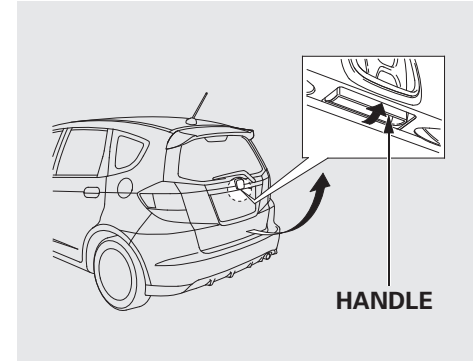

To open the tailgate, pull the handle, then lift up.

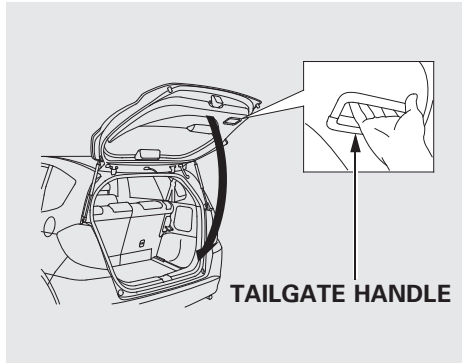

To close the tailgate, hold the tailgate handle, lower the tailgate, then press down on the back edge.

Keep the tailgate closed at all times while driving to avoid damaging the tailgate and to prevent exhaust gas from getting into the interior. See **Carbon Monoxide Hazard** on page 53.

Unlocking the Tailgate

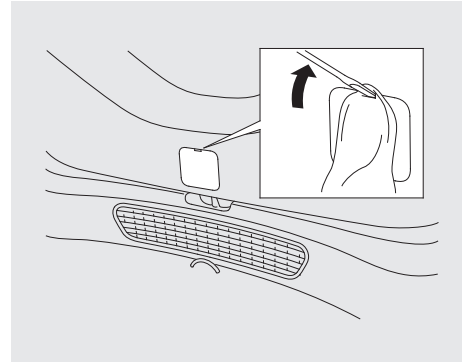

On Sport model and Canadian LX model
If the power door lock system cannot unlock the tailgate, unlock it manually.

Place a cloth on the edge of the cover to prevent scratches, then use a small flat-tip screwdriver to remove the cover on the back of the tailgate.

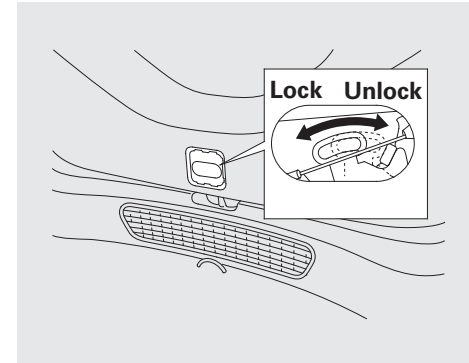

Push the release lever to the right as shown.

If you need to unlock the tailgate manually, it means there is a problem with the tailgate. Have the vehicle checked by your dealer.

Remote Transmitter

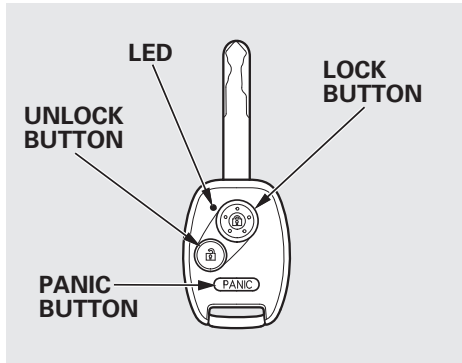

On Sport model and Canadian LX model

LOCK – Press this button once to lock all doors and the tailgate. Some exterior lights will flash once. When you push LOCK twice within 5 seconds, the horn will sound to verify that the doors and the tailgate are locked and the security system (if equipped) has set. You cannot lock the doors and the tailgate if any door or the tailgate is not fully closed or the key is in the ignition switch.

UNLOCK – Press this button once to unlock the driver's door. Push it twice to unlock the remaining doors and the tailgate. Some exterior lights will flash twice each time you press the button.

The ceiling light (if the ceiling light switch is in the door activated position) will come on when you press the UNLOCK button. If you do not open any door or the tailgate within 30 seconds, the light fades out. If you relock the doors and the tailgate with the remote transmitter before 30 seconds have elapsed, the light will go off immediately.

If you do not open any door or the tailgate within 30 seconds, they will automatically relock and the security system (if equipped) will set.

PANIC – Press this button for about 2 seconds to attract attention: the horn will sound, and the exterior lights will flash for about 30 seconds. To cancel panic mode, press any other button on the remote transmitter, or turn the ignition switch to the ON (II) position.

Remote Transmitter

Remote Transmitter Care

- Avoid dropping or throwing the transmitter.
- Protect the transmitter from extreme temperature.
- Do not immerse the transmitter in any liquid.
- If you lose a transmitter, the replacement needs to be reprogrammed by your dealer.

Replacing the Transmitter Battery

If it takes several pushes on the button to lock or unlock the doors and the tailgate, replace the battery as soon as possible.

Battery type: CR1616

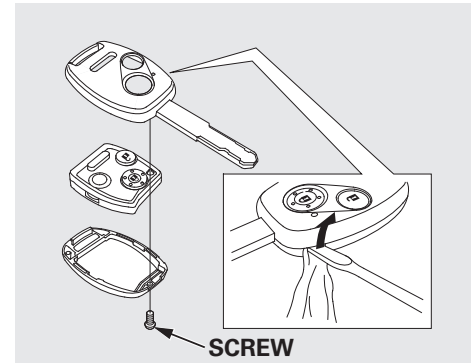

To replace the battery:

1. Remove the screw at the base of the transmitter with a small Phillips-head screwdriver.

NOTE: Be careful not to strip the head when removing this screw.

CONTINUED

Remote Transmitter

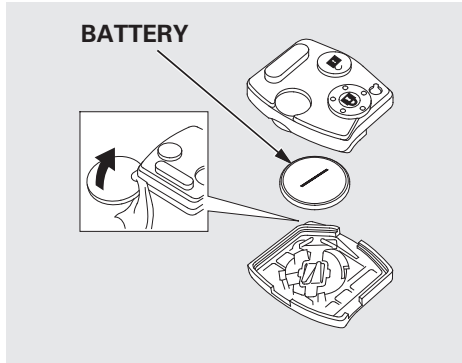

2. Separate the transmitter by prying its middle seam with your fingernail.
3. Inside the transmitter, separate the inner cover from the keypad by carefully prying on the edge with a coin.

4. Remove the old battery, and insert a new battery into the back of the cover with the + side facing down.

An improperly disposed of battery can hurt the environment. Always confirm local regulations for battery disposal.

5. Install the parts in reverse order.

As required by the FCC: This device complies with Part 15 of the FCC rules. Operation is subject to the following two conditions: (1) This device may not cause harmful interference, and (2) this device must accept any interference received, including interference that may cause undesired operation.

Changes or modifications not expressly approved by the party responsible for compliance could void the user's authority to operate the equipment.

This device complies with Industry Canada Standard RSS-210. Operation is subject to the following two conditions: (1) this device may not cause interference, and (2) this device must accept any interference that may cause undesired operation of the device.

Front Seat Adjustments

See pages 11 – 12 for important safety information and warnings about how to properly position the seats and seat-backs.

Make all seat adjustments before you start driving.

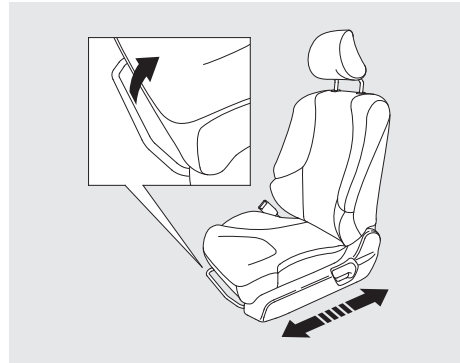

To adjust the seat forward or backward, pull up on the bar under the seat cushion's front edge. Move the seat to the desired position, and release the bar. Try to move the seat to make sure it is locked in position.

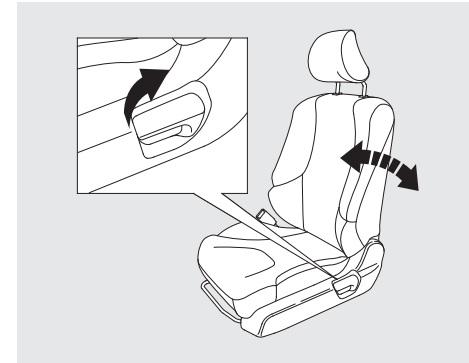

To change the seat-back angle, pull up the lever on the outside of the seat bottom.

Once a seat is adjusted correctly, rock it back and forth to make sure it is locked in position.

CONTINUED

Seats

Armrest

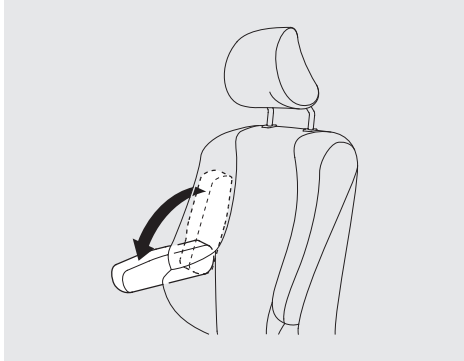

On Sport model and Canadian LX model
The driver's seat has an armrest on the side of the seat-back. To use, pivot it down.

Rear Seat Adjustments

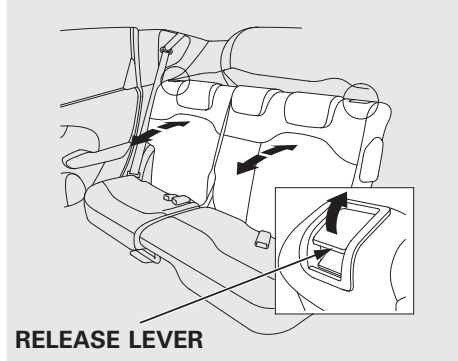

You can adjust the angle of the rear seat-backs separately. To change the seat-back angle, pull up the release lever on the outer side of the seat-back.

Head Restraints

See page 13 for important safety information and a warning about improperly positioning head restraints.

Your vehicle is equipped with head restraints in all seating positions to help protect you and your passengers from the likelihood of whiplash and other injuries.

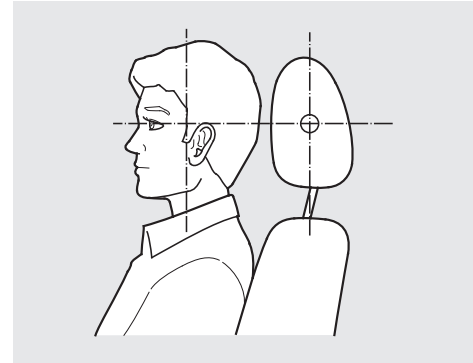

They are most effective when you adjust them so the center of the back of the occupant's head rests against the center of the restraint.

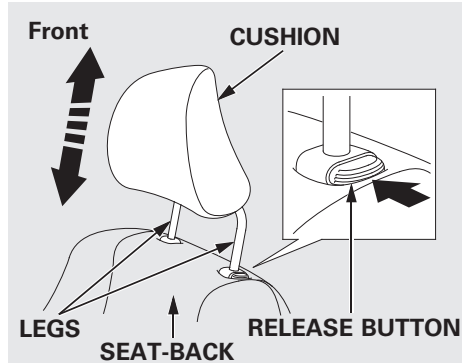

Adjusting the Head Restraint

The head restraints adjust for height. You need both hands to adjust a restraint. Do not attempt to adjust it while driving. To raise it, pull upward. To lower the restraint, push the release button sideways, and push the restraint down.

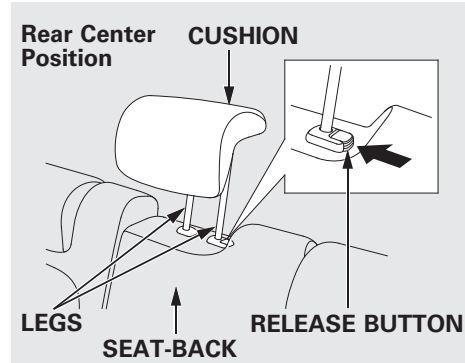

When a passenger is seated in the rear center seating position, the center head restraint should be adjusted up or down, to match the passenger's height.

Removing the Head Restraint

To remove a head restraint for cleaning or repair, pull it up as far as it will go. Push the release button, then pull the restraint out of the seat-back.

⚠ WARNING

Failure to reinstall the head restraints can result in severe injury during a crash.

Always replace the head restraints before driving.

When reinstalling a head restraint, put the legs back in place. Then adjust it to the appropriate height while pressing the release button.

Make sure the head restraint locks in position when you reinstall it.

CONTINUED

Seats

Active Head Restraints

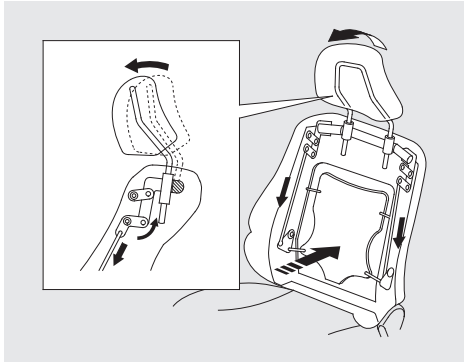

The driver's and front passenger's seats have active head restraints. If the vehicle is struck severely from the rear, the occupant properly secured with the seat belt will be pushed against the seat-back and the head restraint will automatically move forward.

This reduces the distance between the restraint and the occupant's head. It also helps protect the occupants against the likelihood of whiplash and injuries to the neck and upper spine.

After a collision, the activated restraint should return to its normal position.

If the restraints do not return to their normal position, or in the event of a severe collision, have the vehicle inspected by a Honda dealer.

For a head restraint system to work properly:

- Do not hang any items on the head restraints, or from the restraint legs.
- Do not place any object between an occupant and the seat-back.
- Install each restraint in its proper location.
- Only use genuine Honda replacement head restraints.

Folding the Rear Seat Up

The left and right rear seat cushions can be lifted up separately to make room for cargo.

Remove any items from the seat before you fold up the seat cushion.

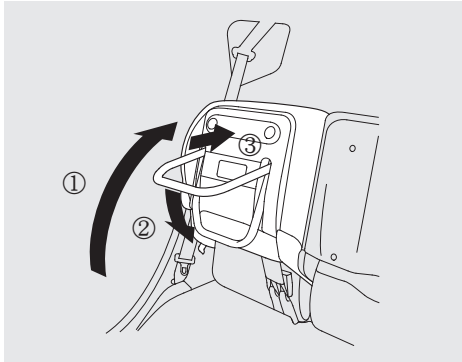

Pull up the rear seat cushion, and fold the seat leg down. Push the seat cushion firmly against the seat-back to lock it.

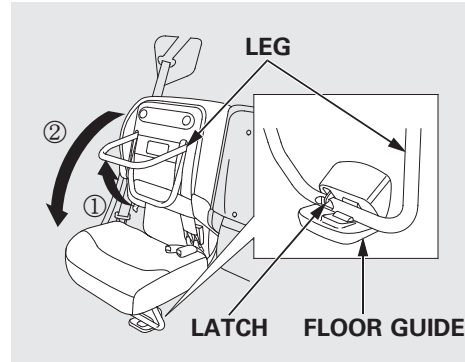

To return the seat cushion to its original position, first make sure there are no items on the floor, then pull up the seat leg fully, and push down the seat cushion slowly while holding it with your hands. Set the seat leg in the floor guide. A latch comes out when the leg is set properly.

Folding the Rear Seat Down

The rear seat-backs can be folded down for more cargo room.

Each side folds down separately, so you can still carry a passenger in the rear outer seating position.

Remove any items from the seat before folding down the seat-back.

Make sure there are no items on the floor before folding down the seats.

CONTINUED

Seats

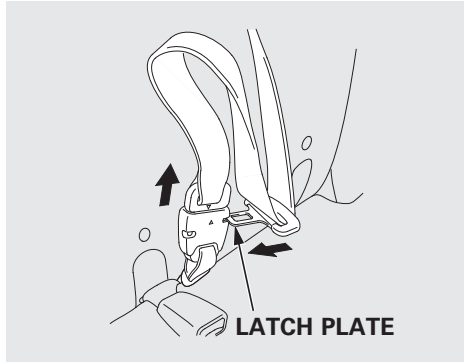

When you fold down the driver's side rear seat, use the latch plate to release the center seat belt from the detachable anchor (see page 99). Allow the seat belt to retract into the holder on the ceiling, and store the buckles in it.

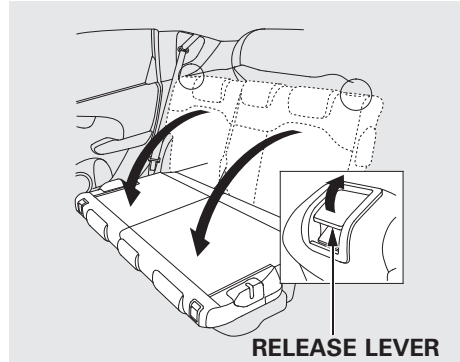

1. Remove all items from the driver's seat-back pocket.
2. Completely lower all rear head restraints to prevent contact with, or possible damage to the pocket.
3. Pull up the release lever on the outside of the seat-back.
4. Fold the seat-back forward.

Do not put any heavy items on the seat-back when it is folded down.

While lifting the seat-back, the seat cushion may come up with it. To secure the seat cushion, see page 97.

Make sure the seat-back and seat cushion are locked securely and all rear shoulder belts are positioned in front of the rear seat-backs. In the center seating position of the rear seat, be sure the detachable anchor is latched securely before using the seat belt (see page 99).

Make sure all items in the cargo area are secured. Loose items can fly forward and cause injury if you have to brake hard (See **Carrying Cargo** on page 208).

Detachable Anchor

The seat belt in the rear center seat is equipped with a detachable anchor.

This allows the center seat belt to be unlatched when the driver's side rear seat is folded.

⚠ WARNING

Using a seat belt with the detachable anchor unlatched increases the chance of serious injury or death in a crash.

Before using the seat belt, make sure the detachable anchor is correctly latched.

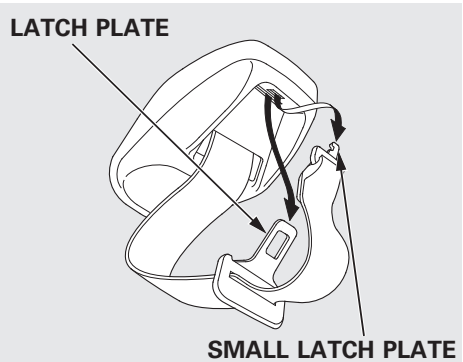

Pull out the small latch plate and the latch plate from each holding slot in the ceiling, and pull out the seat belt to extend it.

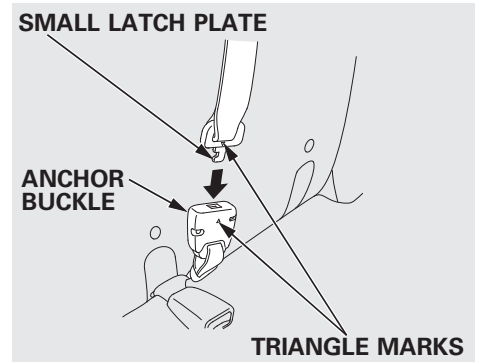

Line up the triangle marks on the small latch plate and anchor buckle when reattaching the belt and buckle.

Tug on the seat belt to verify that the detachable anchor is securely latched. Make sure the seat belt is not twisted.

CONTINUED

Seats, Power Windows

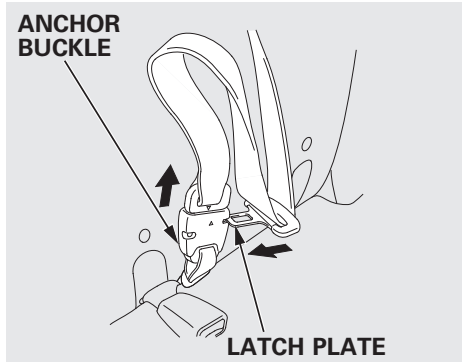

To unlatch the detachable anchor, insert the latch plate into the slot on the side of the anchor buckle. Store the detachable anchor and seat belt latch plates in the retractor housing.

Power Windows

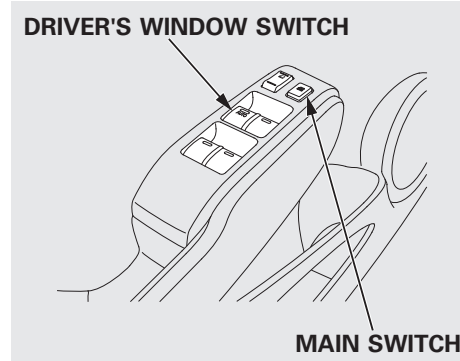

Turn the ignition switch to the ON (II) position to raise or lower any window. To open a window, push the switch down and hold it. Release the switch when you want the window to stop. Pull back on the switch and hold it to close the window.

The windows will operate for up to 10 minutes after you turn off the ignition switch. Opening either front door cancels this function.

⚠ WARNING

Closing a power window on someone's hands or fingers can cause serious injury.

Make sure your passengers are away from the windows before closing them.

When you push the MAIN switch in, the switch is off, and the passenger windows cannot be raised or lowered. To cancel this feature, push on the switch again to get it to pop out. Keep the MAIN switch off when you have children in the vehicle so they do not injure themselves by operating the windows unintentionally.

Power Windows, Mirrors

AUTO – To open or close the driver's window, push or pull the window switch firmly down or up to the second detent, and release it. The window will automatically go down or up all the way. To stop the window, pull or push the window switch briefly.

AUTO REVERSE – If the driver's window senses any obstacle while it is closing automatically, it will reverse direction, and then stop. To close the window, remove the obstacle, then use the window switch again.

Auto reverse stops sensing when the window is almost closed. You should always check that all passengers and objects are away from the window before closing it.

Mirrors

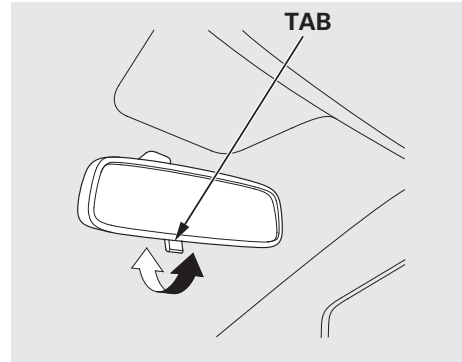

Keep the inside and outside mirrors clean and adjusted for best visibility. Be sure to adjust the mirrors before you start driving.

The inside mirror has day and night positions. The night position reduces glare from headlights behind you. Flip the tab on the bottom edge of the mirror to select the day or night position.

Adjusting the Power Mirrors

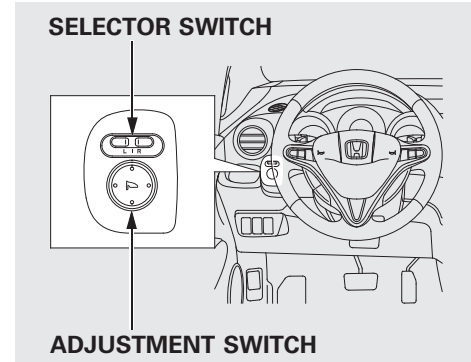

1. Turn the ignition switch to the ON (II) position.
2. Move the selector switch to L (driver's side) or R (passenger's side).

CONTINUED

Mirrors, Parking Brake

3. Push the appropriate edge of the adjustment switch to move the mirror right, left, up, or down.
4. When you finish, move the selector switch to the center (off) position. This turns the adjustment switch off to keep your settings.

Heated Mirrors

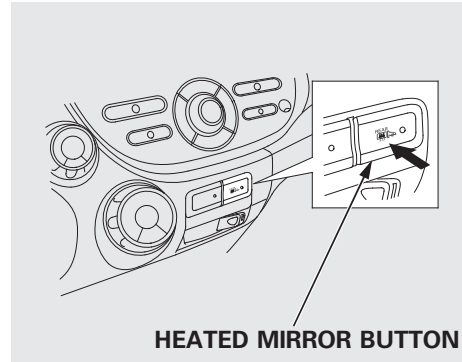

On Canadian Sport and LX models
The outside mirrors are heated to remove fog and frost. With the ignition switch in the ON (II) position, turn on the heaters by pressing the button. The indicator in the button comes on as a reminder. Press the button again to turn the heaters off. Pressing this button also turns the rear window defogger on and off.

Parking Brake

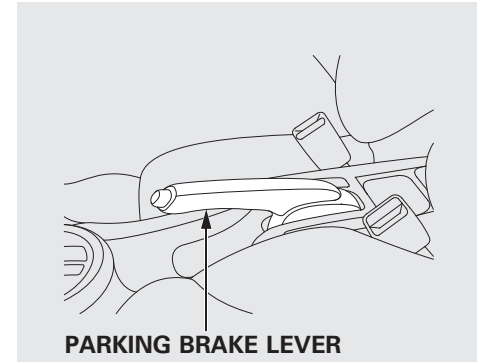

To apply the parking brake, pull the lever up fully. To release it, pull up slightly, push the button, and lower the lever. The parking brake indicator on the instrument panel should go out when the parking brake is fully released (see page 60).

NOTICE

Driving the vehicle with the parking brake applied can damage the rear brakes and axles. A beeper will sound if the vehicle is driven with the parking brake on.

Interior Convenience Items

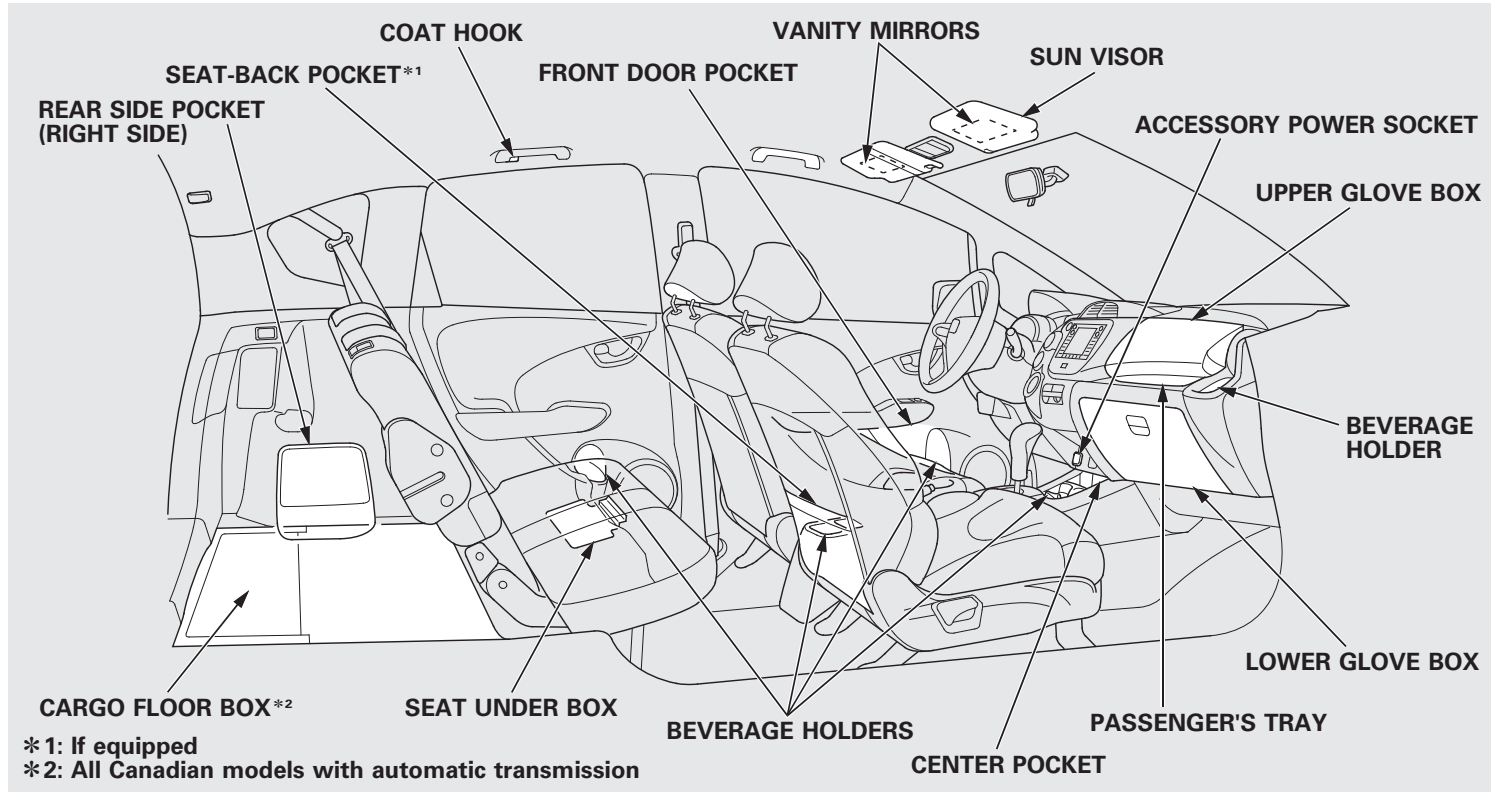

Lower Glove Box

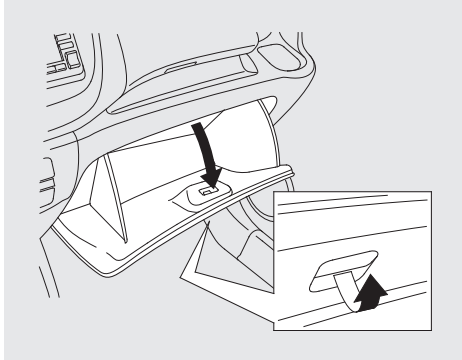

Open the lower glove box by pulling the bottom of the handle. Close it with a firm push.

⚠ WARNING

An open glove box can cause serious injury to your passenger in a crash, even if the passenger is wearing the seat belt.

Always keep the glove box closed while driving.

Upper Glove Box

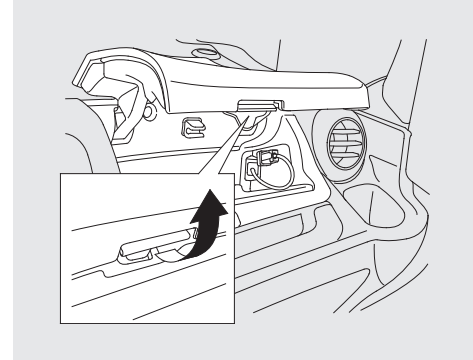

Open the upper glove box by pulling up on the lever. Close it with a firm push.

Interior Convenience Items

Beverage Holders

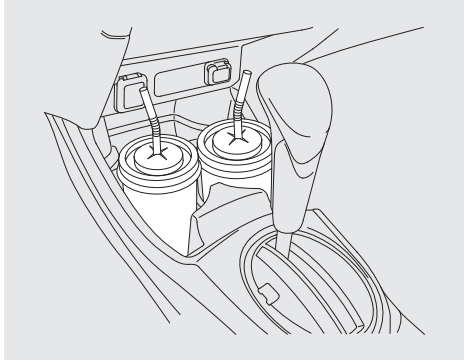

Be careful when you are using the beverage holders. A spilled liquid that is very hot can scald you or your passengers. Liquid can also spill from the door pocket beverage holders when you open or close the doors. Use only resealable containers in the door pockets.

Spilled liquids can damage the upholstery, carpeting, and electrical components in the interior.

Seat Under Box

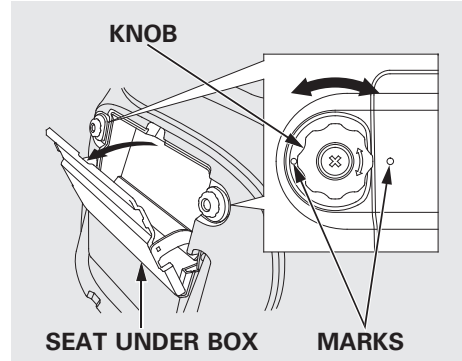

Pull up the driver's side rear seat cushion (see page 97). Open the seat under box by turning the knob. To close the seat under box, turn the knob and align the marks.

Accessory Power Socket

This socket is intended to supply power for 12 volt DC accessories that are rated 120 watts or less (10 amps).

To use the accessory power socket, pull up the cover. The ignition switch must be in the ACCESSORY (I) or ON (II) position.

It will not power an automotive type cigarette lighter element.

Sun Visor

To use the sun visor, pull it down. When using the sun visor for the side window, remove the support rod from the clip, and swing it out.

Make sure you put the sun visor back in place when you are getting into or out of the vehicle.

Ceiling Light

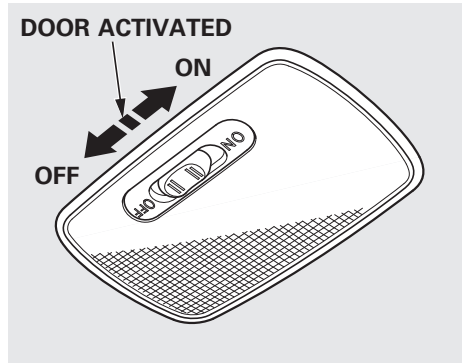

The ceiling light has a three-position switch: ON, Door Activated, and OFF. In the Door Activated (center) position, the light comes on when you:

- Open any door.
- Unlock the doors and the tailgate with the key or the remote transmitter (if equipped).

After all doors are closed tightly, the light fades out in about 30 seconds.

The ceiling light (with the switch in the door activated position) comes on when you remove the key from the ignition switch. If you do not open a door, the light fades out in about 30 seconds.

If you leave any door open without the key in the ignition switch, the ceiling light will go off after 15 minutes.

The heating and air conditioning system in your vehicle provides a comfortable driving environment in all weather conditions.

The standard audio system has many features. This section describes those features and how to use them.

Your vehicle has an anti-theft audio system that requires a code number to enable it.

The security system helps to discourage vandalism and theft of your vehicle.

Vents, Heating, and A/C	110	Disc Player Error Messages (Models with navigation system)	157
Playing the FM/AM Radio (Models without navigation system)	115	Playing a PC card (Models with navigation system)	158
Playing a Disc (Models without navigation system)	122	Playing an iPod® (Models with navigation system)	170
Disc Player Error Messages (Models without navigation system)	128	iPod® Error Messages (Models with navigation system)	176
Playing an iPod® (Models without navigation system)	129	Playing a USB Flash Memory Device (Models with navigation system)	177
iPod® Error Messages (Models without navigation system)	135	USB Flash Memory Device Error Messages (Models with navigation system)	183
Playing a USB Flash Memory Device (Models without navigation system)	136	FM/AM Radio Reception	184
USB Flash Memory Device Error Messages (Models without navigation system)	142	Protecting Your Discs	186
Playing the AM/FM Radio (Models with navigation system)	143	Remote Audio Controls	189
Playing a Disc (Models with navigation system)	149	Auxiliary Input Jack	190
		Radio Theft Protection	191
		Setting the Clock	192
		Security System	193
		Cruise Control	194

Vents, Heating, and A/C

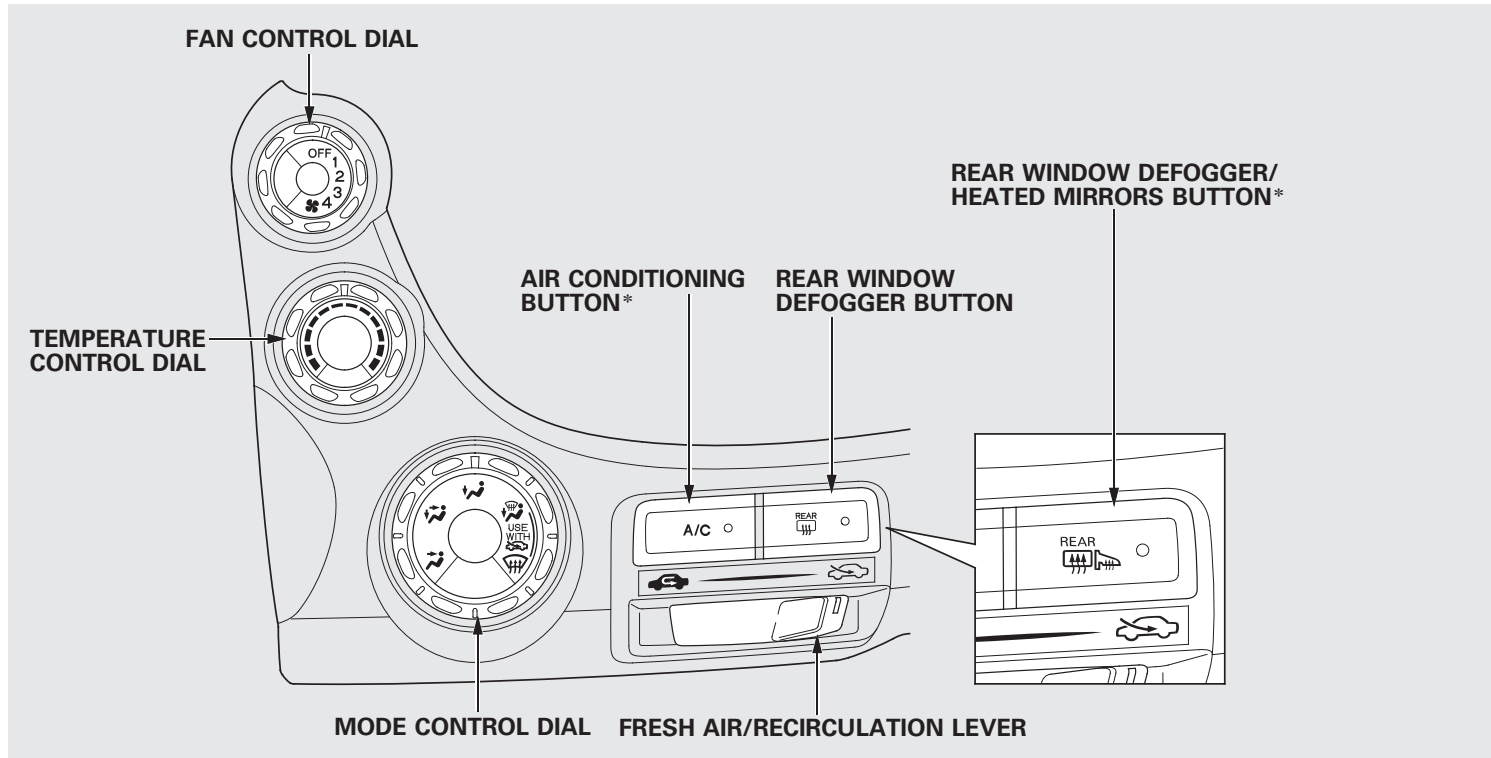

*: If equipped

Airflow Controls

Fan Control Dial

Turn this dial to increase or decrease the fan speed and airflow.

Temperature Control Dial



Turning this dial clockwise increases the temperature of the airflow.

Air Conditioning (A/C) Button

If equipped

This button turns the air conditioning on and off. The indicator in the button is on when the A/C is on.

Fresh Air/Recirculation Lever

This lever controls the source of the air going into the system. When you slide the lever to the  side, air is brought in from outside the vehicle (fresh air mode). When you select the  side, air from the vehicle's interior is sent through the system again (recirculation mode).

The outside air intakes for the heating and cooling system are at the base of the windshield. Keep this area clear of leaves and other debris.

The system should be left in fresh air mode under almost all conditions. Keeping the system in recirculation mode, particularly with the A/C off, can cause the windows to fog up.

Switch to recirculation mode when driving through dusty or smoky conditions, then return to fresh air mode.

Rear Window Defogger

Button 

This button turns the rear window defogger on and off (see page 76).

On some models, this button also operates the heated outside mirrors (see page 102).

Mode Control Dial

Use the mode control dial to select the vents the air flows from. Some air will flow from the dashboard corner vents in all modes.

 Air flows from the center and corner vents in the dashboard.

 Airflow is divided between the vents in the dashboard and the floor vents.



 Air flows from the floor vents.

 Airflow is divided between the floor vents and defroster vents at the base of the windshield.

 Air flows from the defroster vents at the base of the windshield.



CONTINUED

Vents, Heating, and A/C

When you select  or , the system automatically turns on the A/C (if equipped). You cannot turn the A/C off in this mode.



Ventilation

The flow-through ventilation system draws in outside air, circulates it through the interior, then discharges it through vents near the tailgate.

1. Set the temperature to the lower limit.
2. Make sure the A/C is off.
3. Select  and .
4. Set the fan to the desired speed.

Using the Heater



The heater uses engine coolant to warm the air. If the engine is cold, it will be several minutes before you feel warm air coming from the system.

1. Select  and .
2. Set the fan to the desired speed.
3. Adjust the warmth of the air with the temperature control dial.

Using the A/C

If equipped



Air conditioning places an extra load on the engine. Check the high temperature indicator (see page 63). If the indicator begins to blink, turn off the A/C until the indicator goes off.

1. Turn on the A/C by pressing the button. The indicator in the button comes on when a fan speed is selected.
2. Make sure the temperature is set to maximum cool.
3. Select .
4. If the outside air is humid, select recirculation mode. If the outside air is dry, select .
5. Set the fan to the desired speed.

If the interior is very warm, you can cool it down more rapidly by partially opening the windows, turning on the A/C, and setting the fan to maximum speed in .

Dehumidify the Interior



Air conditioning, as it cools, removes moisture from the air. When used in combination with the heater, it makes the interior warm and dry and can prevent the windows from fogging up.



1. Turn the fan on.
 2. If the A/C is off, turn it on (if equipped).
 3. Select  and .
- Adjust the temperature to your preference.

This setting is suitable for all driving conditions whenever the outside temperature is above 32°F (0°C).

To Defog and Defrost

To remove fog from the inside of the windows:



1. Set the fan to the desired speed or high for faster defrosting.
2. Select  by sliding the lever.
3. Select . The system automatically turns on the A/C (if equipped). The A/C indicator will not come on if it was previously off.
4. Adjust the temperature so the airflow feels warm.
5. Select  to help clear the rear window.
6. To increase airflow to the windshield, close the corner vents.

When you select  or , the system automatically turns on the A/C. This helps to dehumidify the air and to defog the windshield. In either mode, you cannot turn off the A/C. When you switch to another mode, the A/C returns to its original setting, either on or off, as indicated by the A/C indicator.

CONTINUED

Vents, Heating, and A/C

To Remove Exterior Frost or Ice From the Windows

1. Set the fan and temperature controls to maximum level.
2. Select . The system automatically turns on the A/C (if equipped). The A/C indicator does not come on if it was previously off.
3. Select .

To clear the windows faster, you can close the dashboard corner vents by rotating each vent. This sends more warm air to the windshield defroster vents. Once the windshield is clear, select fresh air mode to avoid fogging the windows.

For your safety, make sure you have a clear view through all the windows before driving.

To Turn Everything Off

Turning the fan speed control dial all the way to the left shuts the system off.

- Keep the system off for short periods only.
- To keep stale air and mustiness from collecting, you should have the fan running at all times.

Playing the FM/AM Radio (Models without navigation system)

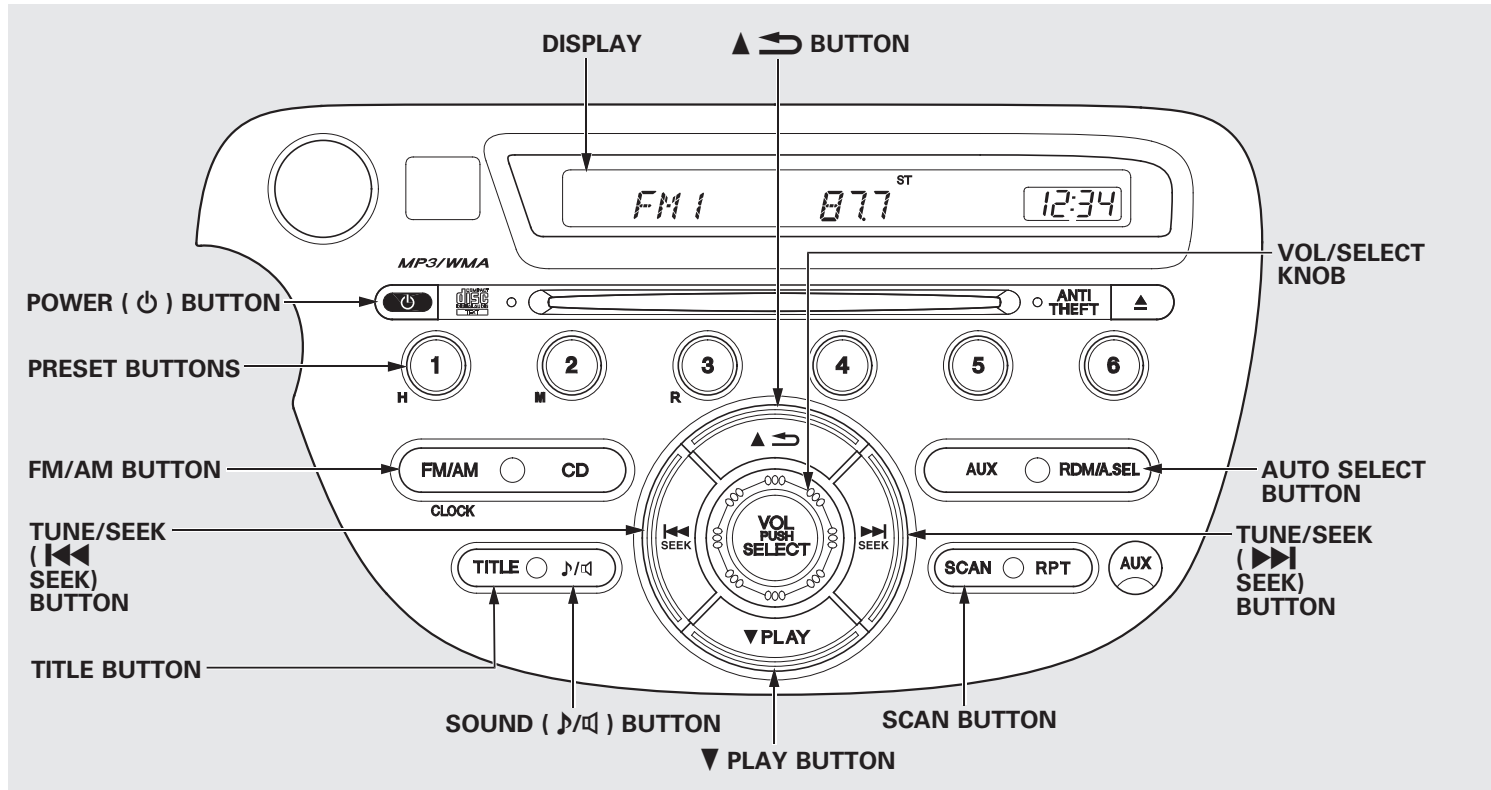

Features

CONTINUED

Playing the FM/AM Radio (Models without navigation system)



To Play the FM/AM Radio

The ignition switch must be in the ACCESSORY (I) or ON (II) position. Turn the system on by pushing the FM/AM button. Adjust the volume by turning the VOL/SELECT knob.

The band and frequency that the radio was last tuned to are displayed. To change bands, press the FM/AM button. On the FM band, ST will be displayed if the station is broadcasting in stereo. Stereo reproduction in AM is not available.



To Select a Station

You can use any of five methods to find radio stations on the selected band: tune, seek, scan, the preset buttons, and auto select.



TUNE – Use the TUNE/SEEK button to tune to a desired frequency. Press the  button to tune to a higher frequency, and the  button to tune to a lower frequency.

You can also operate the tune function by using the VOL/SELECT knob.

Press the VOL/ SELECT knob and you will see “SEL” in the display. Turn the knob right to tune to a higher frequency, or left to tune to a lower frequency.

To turn it off, press the VOL/ SELECT knob or  button, or  PLAY button.

The system will return to the normal display about 10 seconds after you stop adjusting the tune mode.

SEEK – The SEEK function searches up and down from the current frequency to find a station with a strong signal. To activate it, press and hold the  or  side of the TUNE/SEEK button until you hear a beep, then release it.

SCAN – The scan function samples all stations with strong signals on the selected band. To activate it, press the SCAN button, then release it. You will see SCAN in the display. The system will scan for a station with a strong signal. When it finds one, it will stop and play that station for about 10 seconds.

If you do nothing, the system will then scan for the next strong station and play it for 10 seconds. When it plays a station you want to listen to, press the SCAN button again.

Playing the FM/AM Radio (Models without navigation system)

PRESET – Each preset button (1 – 6) can store one frequency on AM, and two frequencies on FM.

1. Select the desired band, AM or FM. FM1 and FM2 let you store two frequencies with each preset button.
2. Use the tune, seek, or scan function to tune the radio to a desired station.
3. Pick a preset number (1 – 6), and hold it until you hear a beep.
4. Repeat steps 1 through 3 to store a total of six stations on AM and twelve stations on FM.

AUTO SELECT – If you are traveling far from home and can no longer receive your preset stations, you can use the auto select feature to find stations in the local area.

Press the A.SEL button. “A.SEL” flashes in the display, and the system goes into scan mode for several seconds. It stores the frequencies of six AM and twelve FM stations in the preset buttons.

You will see a “0” displayed after pressing a preset button if auto select cannot find a strong station for that preset button.

If you do not like the stations auto select has stored, you can store other frequencies on the preset buttons as previously described.

To turn off auto select, press the A.SEL (auto select) button. This restores the presets you originally set.

For information on FM/AM radio frequencies and reception, see page 184.

CONTINUED

Playing the FM/AM Radio (Models without navigation system)

Radio Data System (RDS)

On the FM band, you can select a favorite station and display the program service name according to the information provided by the radio data system (RDS).

Program Service (PS) Name Display

The program service name display function shows the name of the station you are listening to. With the audio system on and the FM band selected, you can turn this function on or off.

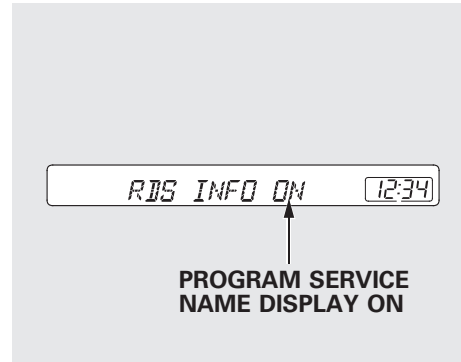

To switch the function between on and off, press and release the TITLE button. With the system on, you will see the “RDS INFO ON” message on the display. If the station you are listening to is an RDS station, the displayed frequency switches to the station name.

If the station you are listening to is not an RDS station, the display continues to show the frequency with the PS name display function on.

When you turn off this function by pressing the TITLE button, the display shows “RDS INFO OFF.”

Playing the FM/AM Radio (Models without navigation system)

Radio Data System (RDS) Category

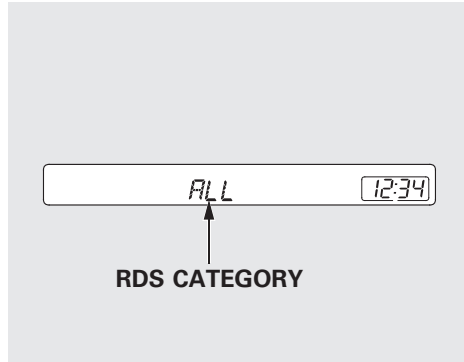



On the FM band selected, you can select the program category provided by the RDS. Press ▲  or ▼ PLAY button to display and select an RDS category. The principal RDS categories are shown as follows;

ALL: All RDS category stations
ROCK: Rock, classic rock and soft rock music
COUNTRY: Country music
SOFT: Adult hits and soft music
TOP 40: Top 40 hits
OLDIES: Nostalgia music and oldies
R & B: Rhythm and blues, and soft rhythm and blues
RELIGION: Religious music and religious talk
CLASSIC: Classical music
JAZZ: Jazz
INFO: News, information, sports, talk, foreign language, personality, public, college, and weather
TRAFFIC: Traffic information

Press ▲  or ▼ PLAY button to select an RDS category. The display shows the selected RDS category name for about 10 seconds. You can use the search or scan function to find radio stations in the selected RDS category. If you do nothing while the RDS category name is displayed, the selected category is canceled.

RDS Program Search

This function searches up and down a frequency for the strongest signal from the frequencies that carry the selected RDS category information. This can help you to find a station in your favorite category. To activate it, press the  or  side of the TUNE/SEEK button. You will see the selected RDS category name blinking while searching it. When the system finds a station, the selected RDS category name will be displayed again for about 5 seconds.

CONTINUED

Playing the FM/AM Radio (Models without navigation system)

If the system does not find a station, “NOTHING” will be blinking for about 5 seconds, then the system goes back to the last selected station.

RDS Program SCAN

The scan function samples all stations with strong signals on the selected RDS category. To activate it, press the SCAN button. You will see “SCAN” in the display. The system will scan for a station with a strong signal in the selected RDS category. You will also see the selected RDS category name blinking while searching it. When it finds one, it will stop and play that station for about 10 seconds.

If you do nothing, the system will scan for the next strong station and play it for 10 seconds. When it plays a station that you want to listen to, press the SCAN button again.

If the system does not find a station, “NOTHING” will be blinking for about 5 seconds, then the system goes back to the last selected station.

You can use the RDS program search or scan function even if the PS name display function is off. In this case, the display shows a frequency in place of a PS name.

Playing the FM/AM Radio (Models without navigation system)

Adjusting the Sound

Press the SOUND (🔊/🔊) button to select an appropriate setting: bass, treble, fader, balance, and SVC (speed-sensitive volume compensation). Turn the VOL/SELECT knob to adjust the setting.

BASS – Adjusts the bass.

TREBLE – Adjusts the treble.

FADER – Adjusts the front-to-back strength of the sound.

BALANCE – Adjusts the side-to-side strength of the sound.

Each mode is shown in the display as it changes. Turn the VOL/SELECT knob to adjust the setting to your liking. When the level reaches the center, you will see “C” in the display.

SVC – Adjusts the volume level based on the vehicle speed.

The system will return to the audio display about 10 seconds after you stop adjusting a mode.

Speed-sensitive Volume Compensation (SVC)

The SVC mode controls the volume based on vehicle speed. The faster you go, the louder the audio volume becomes. As you slow down, the audio volume decreases.

The SVC has four modes; SVC OFF, SVC LOW, SVC MID, and SVC HIGH. Turn the VOL/SELECT knob to adjust the setting to your liking. If you feel the sound is too loud, choose low. If you feel the sound is too quiet, choose high.

This function is set to MID as the default setting when the vehicle leaves the factory.

Audio System Lighting

You can use the instrument panel brightness control knob to adjust the illumination of the audio system (see page 76). The audio system illuminates when the parking lights are on, even if the system is turned off.

Playing a Disc (Models without navigation system)

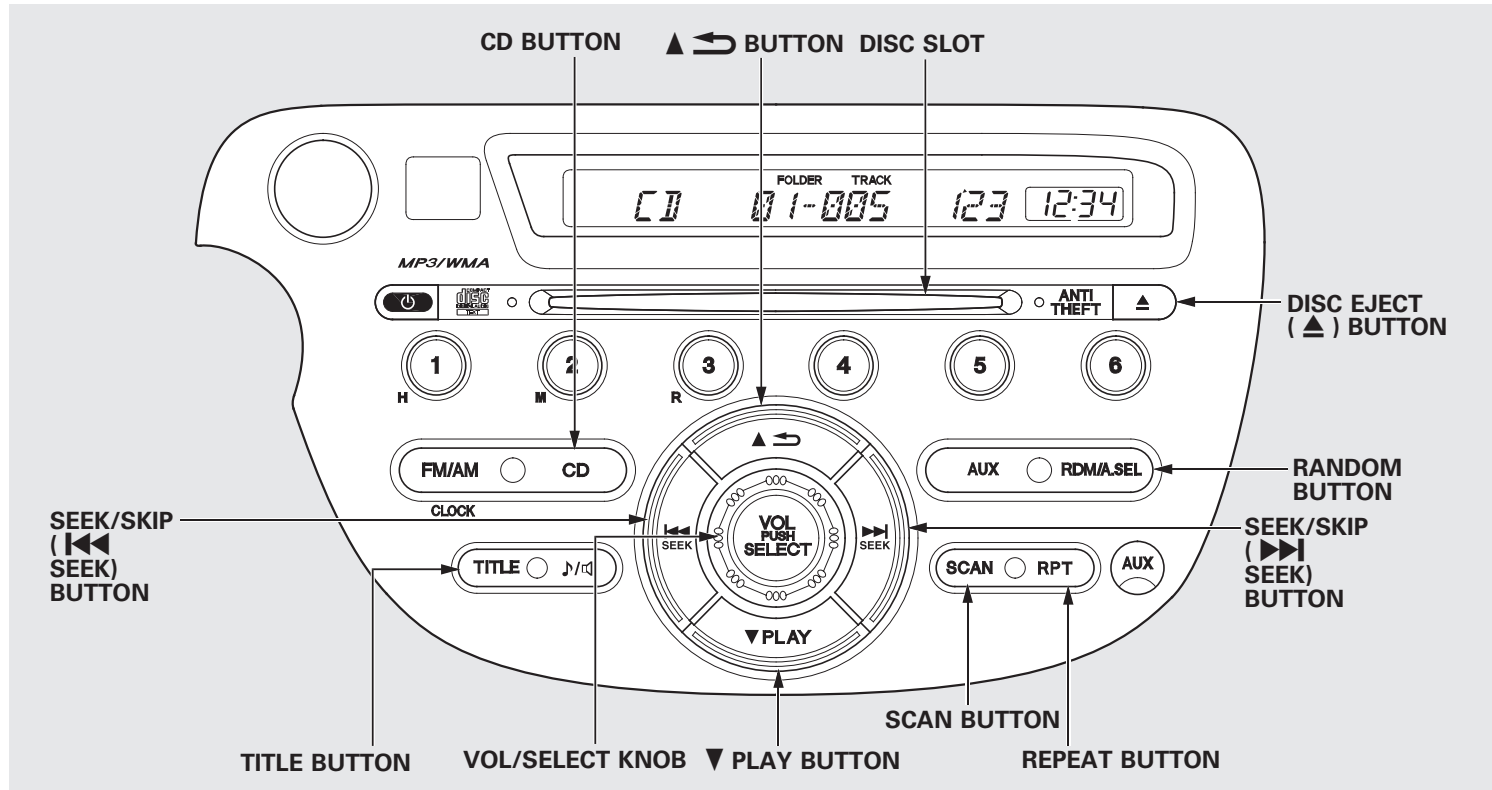

Playing a Disc (Models without navigation system)

To Play a Disc

To load or play discs, the ignition switch must be in the ACCESSORY (I) or ON (II) position.

You operate the in-dash disc player with the same controls used for the radio. To select the disc player, press the CD button. You will see “CD” in the display. The folder or track numbers are shown in the display. You can also select the displayed information with the TITLE button (see page 123). The system will continuously play a disc until you change modes.

NOTICE

Do not use discs with adhesive labels. The label can curl up and cause the disc to jam in the unit.

The in-dash disc player can also play CD-Rs and CD-RWs compressed in CD-TEXT, MP3, and WMA formats. When playing a disc in MP3 or WMA, you will see “MP3” or “WMA” in the display. You can see up to 99 folders, and select up to 999 tracks/files.

NOTE: If a file on an MP3 or WMA disc is protected by digital rights management (DRM), the audio unit displays UNSUPPORTED, and then skips to the next file.

If you have a disc that is a combination of CD-DA tracks and MP3/WMA files, you can choose the format to listen by pressing the CD button.

Video CDs and DVDs will not work in this unit.

A disc compressed in AAC format cannot be played in this audio system.

CONTINUED

Playing a Disc (Models without navigation system)

The specifications of the compatible MP3 file are:

Sampling frequency:

32/44.1/48 kHz (MPEG1), 24/
22.05/16 kHz (MPEG2)

Bit rate:

32/40/48/56/64/80/96/112/128/
160/192/224/256/320 kbps
(MPEG1),

8/16/24/32/40/48/56/64/80/96/
112/128/160 kbps (MPEG2)

Compatible with variable bit rate and multi-session.

Maximum layers (including ROOT):
8 layers

The specifications of the compatible WMA file are:

Sampling frequency:

32/44.1/48 kHz

Bit rate:

48/64/80/96/128/160/192 kbps

Compatible with variable bit rate and multi-session.

Maximum layers (including ROOT):
8 layers

To Load a Disc

Insert a disc about halfway into the disc slot. The drive will pull the disc in the rest of the way to play it. You operate the disc player with the same controls used for the radio. The number of the current track is shown in the display. When playing a disc in MP3 or WMA, the numbers of the current folder and file are shown. The system will continuously play a disc until you change modes.

You cannot load and play 3-inch (8-cm) discs in this unit.

For information on how to handle and protect compact discs, see page 186.

Text Data Display Function

Each time you press the TITLE button, the display shows you the text data on a disc, if the disc was recorded with text data.

You can see the album, artist, and track name in the display. If a disc is recorded in MP3 or WMA, you can see the folder and file name, and the artist, album, and track tag.

With the folder name, you will see the FOLDER indicator in the display. The TRACK indicator is shown with the file or track name.

When you press the TITLE button while a disc without text data is playing, you will see "NO INFO" on the display.

The display shows up to about 16 characters of selected text data (the folder name, file name, etc.).

If the text data has more than 16 characters, you will see the first 15 characters and the ► indicator on the display. Press and hold the TITLE button until the next 16 characters are shown. You can see up to about 31 characters of the text data.

Playing a Disc (Models without navigation system)

If you press and hold the TITLE button again, the display shows the first 15 characters again.

If any letter is not available, it is replaced with “.” (dot) in the display. When the disc has no text data, you will see “NO INFO” on the display.

You will also see some text data under these conditions:

- When a new folder, file, or track is selected.
- When you change the audio mode to play a disc with text data or in MP3 or WMA.
- When you insert a disc, and the system begins to play.



When playing a CD-DA with text data, the album and track name are shown in the display. With a disc in MP3 or WMA, the display shows the folder and file name.



When you turn on the audio system next time, the system keeps your selection with the TITLE button.

To Change or Select Tracks/Files

You can use the SEEK/SKIP button while a disc is playing to select passages and change tracks (files in MP3/WMA mode).

In MP3/WMA mode, use the ▲ ↶ or ▼ PLAY button to select folders in the disc, and use the SEEK/SKIP button to change files.

SEEK/SKIP – Each time you press the  button, the player skips forward to the beginning of the next track (files in MP3/WMA mode). Press the  button to skip backward to the beginning of the current track. Press it again to skip to the beginning of the previous track.



To move rapidly within a track, press and hold the  or  button.

You can also operate the track selection by using the VOL/SELECT knob. Press the VOL/SELECT knob and you will see “SEL” in the display. Turn the knob to switch the track number. Press the VOL/SELECT knob or ▼ PLAY button to set your selection. To turn it off, press the ▲ ↶ button.

CONTINUED

Playing a Disc (Models without navigation system)

In MP3/WMA mode

FOLDER SELECTION – To select a different folder, press the ▲  or ▼ PLAY button. Press the ▲  button to skip to the next folder, and the ▼ PLAY button to skip to the previous folder.

You can also operate the folder and file selection by using the VOL/SELECT knob. Press the VOL/SELECT knob and you will see “SEL” in the display. Turn the knob to switch the folder number and press the knob to set your selection. Turn the knob to switch the file number and press the knob to your selection. To turn it off, press the ▲  button repeatedly.

REPEAT (TRACK/FILE REPEAT)

– To continuously replay a track (file in MP3/WMA mode), press the RPT button. You will see “RPT” in the display. Press and hold the RPT button to turn it off.

In MP3/WMA mode

FOLDER-REPEAT – This feature, when activated, replays all the files on the selected folder in the order they are compressed in MP3/WMA. To activate folder repeat mode, press the RPT button repeatedly until you see “F-RPT” in the display. The system continuously replays the current folder. Press and hold the RPT button to turn it off.

Each time you press the RPT button, the mode changes from file repeat to folder repeat, then to normal playing.

RANDOM (Random within a disc)

– This feature plays the tracks within a disc in random order. In MP3/WMA mode, all files in all folders are played in random order. To activate random mode, press the RDM button repeatedly until you see “RDM” in the display. Press and hold the RDM button to turn it off.

In MP3/WMA mode

FOLDER-RANDOM – This feature, when activated, plays the files in the current folder in random order, rather than in the order they are compressed in MP3/WMA. To activate folder random play, press the RDM button. You will see “F-RDM” in the display. The system will then select and play files randomly. This continues until you deactivate folder random play by pressing and holding the RDM button.

Each time you press the RDM button, the mode changes from folder random play, to within a disc random play, then to normal play.

Playing a Disc (Models without navigation system)

SCAN – The scan function samples all the tracks on the disc in the order they are recorded on the disc (all files in the selected folder in MP3 or WMA mode). To activate the scan feature, press the SCAN button. You will see “SCAN” in the display. You will get a 10 second sampling of each track/file in the disc/folder. Press and hold the SCAN button to get out of scan mode and play the last track sampled.

In MP3/WMA mode

FOLDER-SCAN – This feature, when activated, samples the first file in each folder on the disc in the order they are recorded. To activate the folder scan feature, press the SCAN button repeatedly. You will see “F-SCAN” in the display. The system will then play the first file in the main folders for about 10 seconds. If you do nothing, the system will then play the following first files for 10 seconds each. When the system samples the first file of all folders, F-SCAN is cancelled, and the system plays normally.

Each time you press the SCAN button, the mode changes from track/file scan to folder scan, then to normal playing.

To Stop Playing a Disc

Press the eject button (▲) to remove the disc. If you eject the disc, but do not remove it from the slot, the system will automatically reload it after 10 seconds and put it in pause mode. To begin playing, press the CD button.

Press the FM/AM button to switch to the radio while a disc is playing. Press the CD button to play the disc.

If you turn the system off while a disc is playing, either with the power (⏻) button or by turning off the ignition switch, the disc will stay in the drive. When you turn the system back on, the disc will begin playing where it left off.

Protecting Discs

For information on how to handle and protect compact discs, see page 186.

Disc Player Error Messages (Models without navigation system)

The chart on the right explains the error messages you may see in the display while playing a disc.

If you see an error message in the display while playing a disc, press the eject button. After ejecting the disc, check it for damage or deformation. If there is no damage, insert the disc again. For the additional information on damaged discs, see page 187.

The audio system will try to play the disc. If there is still a problem, the error message will reappear. Press the eject button, and pull out the disc.

Insert a different disc. If the new disc plays, there is a problem with the first disc. If the error message cycle repeats and you cannot clear it, take your vehicle to a dealer.

Error Message	Cause	Solution
HEAT ERROR	High Temperature	Will disappear when the temperature returns to normal.
UNSUPPORTED	Track/File format not supported	Current track will be skipped. The next supported track or file plays automatically.
BAD DISC PLEASE CHECK OWNERS MANUAL PUSH EJECT	Mechanical Error	Press the EJECT button and pull out the disc. Check the disc for serious damage, signs of deformation, excessive scratches, and/or dirt (see page 187). Insert the disc again. If the code does not disappear, or the disc cannot be removed, consult your dealer. Do not try to force the disc out of the player.
BAD DISC PLEASE CHECK OWNERS MANUAL	Servo Error	
BAD DISC PLEASE CHECK OWNERS MANUAL	DISC Error	Check the disc for serious damage, signs of deformation, excessive scratches, and/or dirt (see page 187).

Playing an iPod® (Models without navigation system)

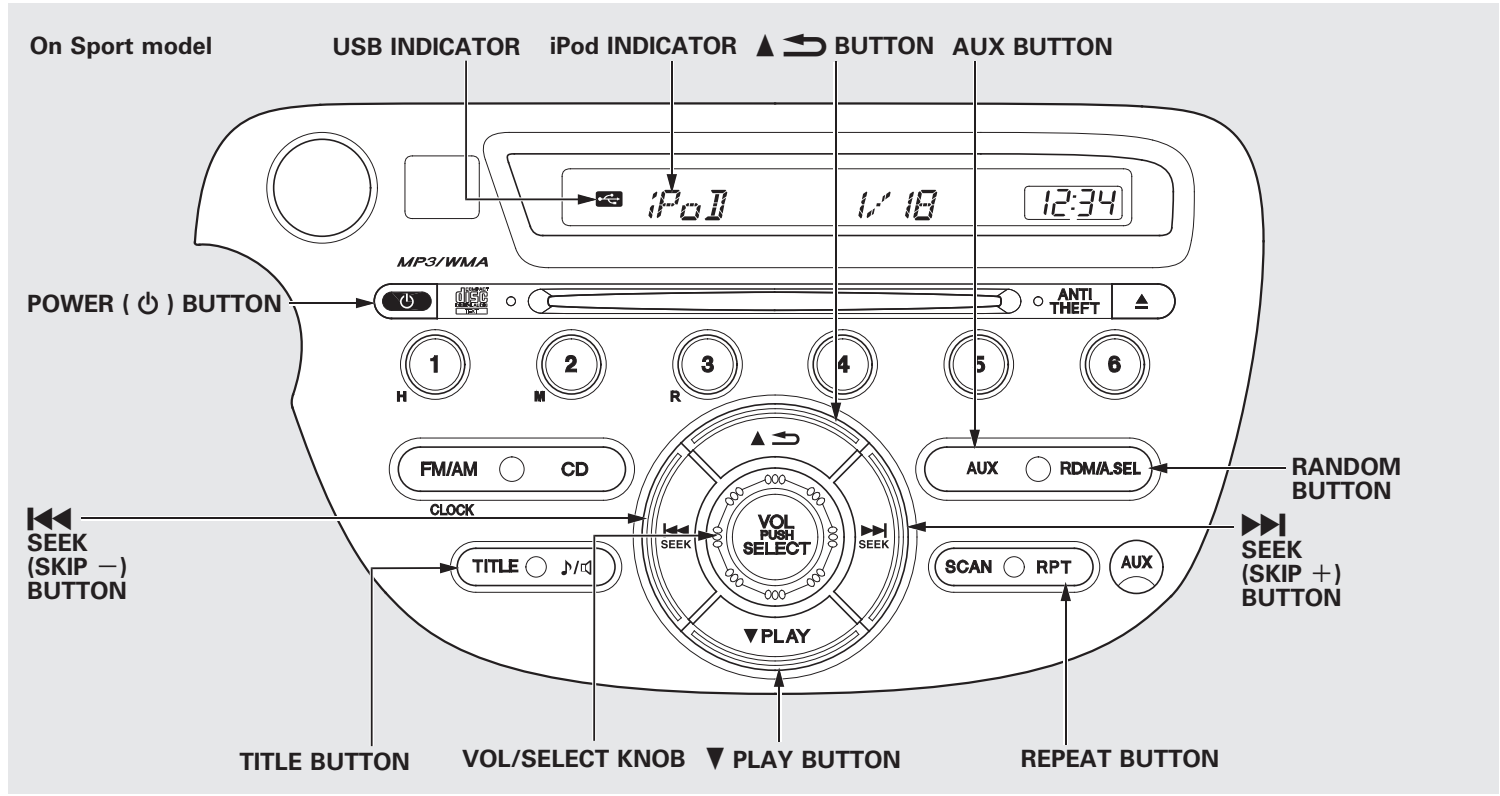

CONTINUED

Playing an iPod® (Models without navigation system)

To Play an iPod®

This audio system can operate the audio files on the iPod® with the same controls used for the in-dash disc player. To play an iPod, connect it to the USB adapter cable in the upper glove box by using your dock connector, then press the AUX button. The ignition switch must be in the ACCESSORY (I) or ON (II) position. The iPod will also be recharged with the ignition switch in these positions.

The audio system reads and plays sound files to be playable on the iPod. The system cannot operate an iPod as a mass storage device. The system will only play songs stored on the iPod with iTunes.

iPod and iTunes are registered trademarks owned by Apple Inc.

iPods compatible with your audio system using the USB adapter cable are:

Model	Software
iPod classic	Ver. 1.0 or more
iPod with video (iPod 5th generation)	Ver. 1.2 or more
iPod nano	Ver. 1.2 or more
iPod nano 2nd generation	Ver. 1.1.2 or more
iPod nano 3rd generation	Ver. 1.0 or more
iPod touch	Ver. 1.1.1 or more

Use only compatible iPods with the latest software. iPods that are not compatible will not work in this audio unit.

NOTE:

- Do not connect your iPod using a HUB.
- Do not keep the iPod in the vehicle. Direct sunlight and high heat will damage it.

- Do not use an extension cable between the USB adapter cable equipped with your vehicle and your dock connector.
- We recommend backing up your data before playing it.

In AAC format, DRM (digital rights management) files cannot be played. If the system finds a DRM file, the audio unit displays UNPLAYABLE, and then skips to the next file.

Playing an iPod® (Models without navigation system)

Connecting an iPod

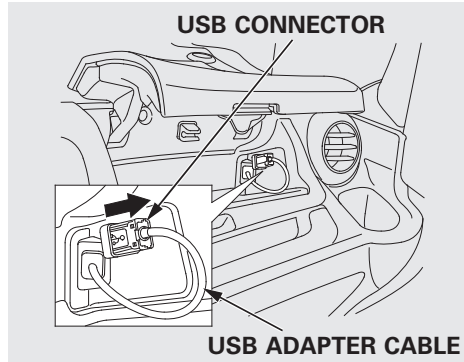

1. Open the upper glove box, and pull out the USB adapter cable.

DOCK CONNECTOR

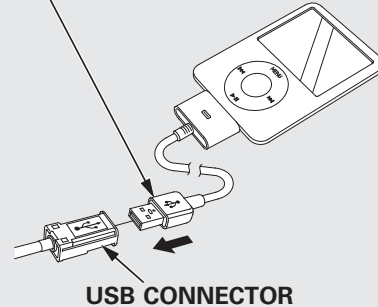

2. Connect your dock connector to the iPod correctly and securely.
3. Install the dock connector to the USB connector securely.

Text Data Display Function

Each time you press the TITLE button the display mode switches between the album name, the song name, the artist name, or name off (which turns off the text display).

Playing an iPod® (Models without navigation system)

The display shows up to about 16 characters of the selected data. If the text data has more than 16 characters, you will see the first 15 characters and the ► indicator in the display. Press and hold the TITLE button until the next 16 characters are shown.

To Change or Select Files

Use the SKIP button while an iPod is playing to select passages and change files.

SKIP – Each time you press the ►►_{SEEK} (SKIP +) button, the system skips forward to the beginning of the next file. Press the ◀◀_{SEEK} (SKIP –) button, to skip backward to the beginning of the current file. Press it again to skip to the beginning of the previous file.

To move rapidly within a file, press and hold either side (►►_{SEEK} or ◀◀_{SEEK}) of the SKIP button.

Playing an iPod® (Models without navigation system)

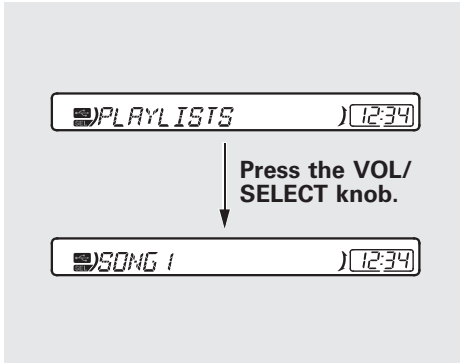

You can also select a file from any list on the iPod menu: playlists, artists, albums and songs, by using the VOL/SELECT knob. Push the VOL/SELECT knob to switch the display to an iPod menu, then turn the VOL/SELECT knob to select a desired list. Press the VOL/SELECT knob to set your selection.

The display shows items on the selected list. Turn the VOL/SELECT knob to select an item, then press the VOL/SELECT knob to set your selection.

If you select “ALL,” all available files on the selected list are played.

Pressing the **▲** **↩** button goes back to the previous display and pressing the **TITLE** button cancels this setting mode.

To Select Repeat or Shuffle Mode:

You can select any type of repeat and shuffle mode by using the RPT button or the RDM button.

REPEAT – This feature continuously plays a file. To activate the repeat feature, press the RPT button. You will see “RPT” in the display. To turn it off, press the RPT button again.

SHUFFLE ALL – This feature plays all available files in a selected list (playlists, artists, albums or songs) in random order. To activate the shuffle all feature, press the RDM button. You will see “RDM” in the display. To turn it off, press and hold the RDM button.

CONTINUED

Playing an iPod® (Models without navigation system)

SHUFFLE ALBUM – This feature plays all available albums in a selected list (playlists, artists, albums or songs) in random order. The files in each album are played in the recorded order. To activate the shuffle album feature, press the RDM button repeatedly. You will see “F-RDM” in the display. To turn it off, press and hold the RDM button.

Each time you press the RDM button, the mode changes from shuffle all play to shuffle album play, then to normal playing.

To Stop Playing Your iPod

To play the radio when an iPod is playing, press the FM/AM button. If a disc is in the audio unit, press the CD button to play the disc.

Disconnecting an iPod

You can disconnect the iPod at any time when you see “OK to Disconnect” message* in the iPod display. Always make sure you see “OK to Disconnect” message in the iPod display before you disconnect it. Make sure to follow the iPod's instructions on how to disconnect the dock connector from the USB adapter cable.

*: The displayed message may vary on models or versions. On some models, there is no message to disconnect.

If you reconnect the same iPod, the system may begin playing where it left off, depending on what mode the iPod is in when it is reconnected.

When you disconnect the iPod while it is playing, the display shows “USB NO DATA.”

iPod Error Messages

If you see an error message in the display, see page 135.

iPod® Error Messages (Models without navigation system)

If you see an error message on the audio display while playing an iPod, find the solution in the chart to the right. If you cannot clear the error message, take your vehicle to your dealer.

Error Message	Solution
UNPLAYABLE FILE	The system cannot read the file(s). Check the files in the iPod. There is a possibility that the files have been damaged.
UNSUPPORTED VER.	Appears when an unsupported iPod is inserted.

Playing a USB Flash Memory Device (Models without navigation system)

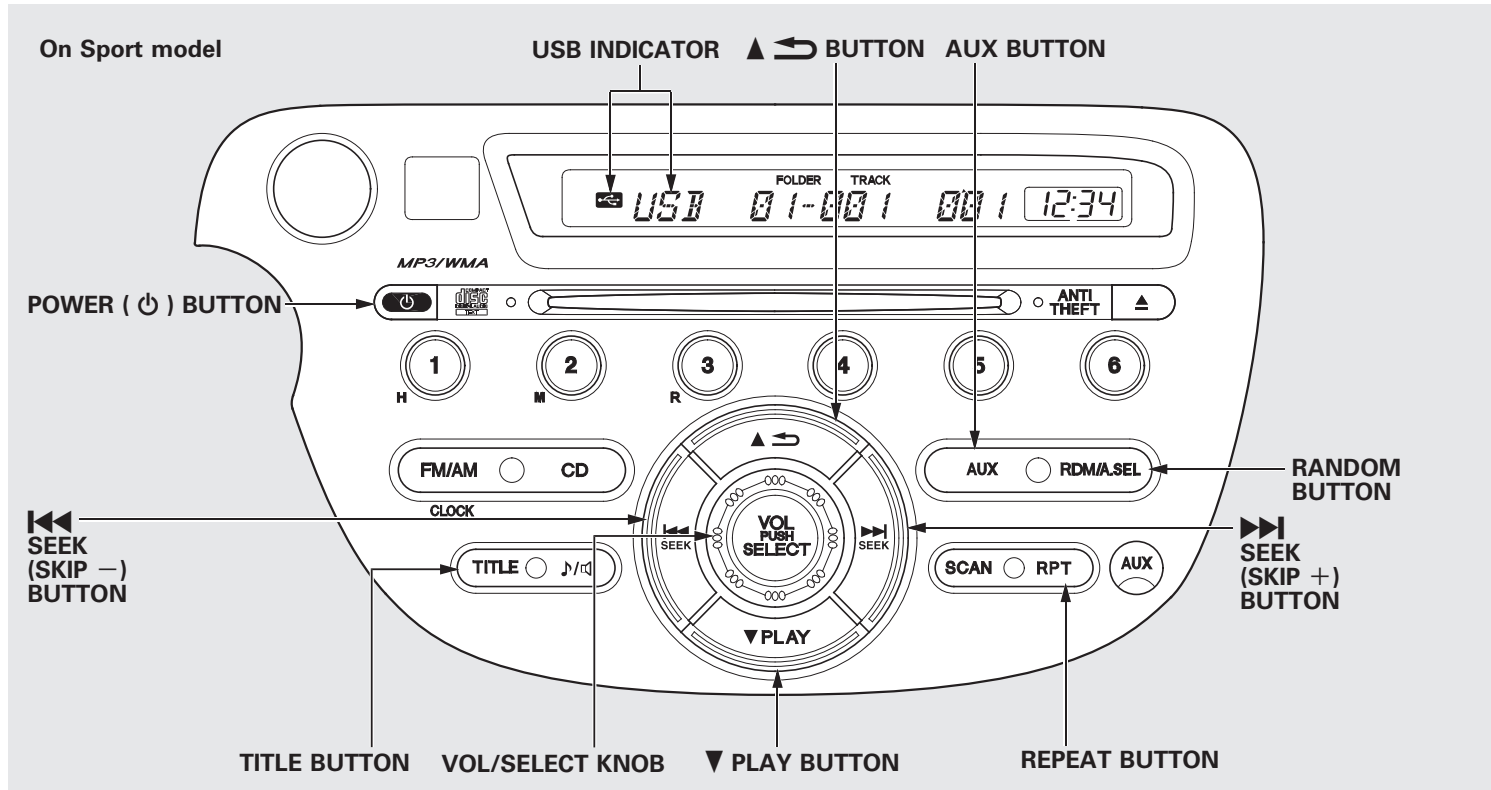

Playing a USB Flash Memory Device (Models without navigation system)

To Play a USB Flash Memory Device

This audio system can operate the audio files on a USB flash memory device with the same controls used for the in-dash disc player. To play a USB flash memory device, connect it to the USB adapter cable in the upper glove box, then press the AUX button. The ignition switch must be in the ACCESSORY (I) or ON (II) position.

The audio system reads and plays the audio files on the USB flash memory device in MP3, WMA or AAC* formats. Depending on the format, the display shows MP3, WMA or AAC when a USB flash memory device is playing. The USB flash memory device limit is up to 700 folders or up to 65535 files.

*: Only AAC format files recorded with iTunes are playable on this audio unit.

The recommended USB flash memory devices are 256 Mbyte or higher, and formatted with the FAT file system. Some digital audio players may be compatible as well.

Some USB flash memory device (such as devices with security lockout features, etc.) will not work in this audio unit.

NOTE:

- Do not use a device such as a card reader or hard drive as the device or your files may be damaged.
- Do not connect your USB flash memory device using a HUB.
- Do not use an extension cable to the USB adapter cable equipped with your vehicle.
- Do not keep the USB flash memory device in the vehicle. Direct sunlight and high heat will damage it.

- We recommend backing up your data before playing a USB flash memory device.
- Depending on the type and number of files, it may take some time before they begin to play.
- Depending on the software the files were made with, it may not be possible to play some files, or display some text data.

The specifications for compatible MP3 files are:

- Sampling frequency:
32/44.1/48 kHz (MPEG1)
16/22.05/24 kHz (MPEG2)
- Bit rate:
32/40/48/56/64/80/96/112/128/
160/192/224/256/320/VBR kbps
(MPEG1)
8/16/24/32/40/48/56/64/80/96/
112/128/144/160/VBR kbps
(MPEG2)

CONTINUED

Playing a USB Flash Memory Device (Models without navigation system)

- Supported standards:
MPEG1 Audio Layer3
MPEG2 Audio LSF Layer3
 - Partition: Top partition only
 - Maximum layers: 8
- The specifications for compatible WMA files are:
- Sampling frequency:
32/44.1/48 kHz
 - Bit rate:
48 – 320/VBR kbps (Max 384)
 - Supported standards:
WMA version 7/8/9
 - Partition: Top partition only
 - Maximum layers: 8
- The specifications for compatible AAC files are:
- Sampling frequency:
8/11.025/12/16/22.05/24/32/
44.1/48 kHz

- Bit rate:
8 – 320 kbps
- Supported standards:
MPEG4/AAC LC
MPEG2/AAC LC
- Partition: Top partition only
- Maximum layers: 8

Even if recorded in MP3, WMA or AAC format, a file with unsupported version cannot be played. If the system finds it, the audio unit displays UNSUPPORTED, and then skips to the next file.

In WMA or AAC format, DRM (digital rights management) files cannot be played. If the system finds a DRM file, the audio unit displays UNPLAYABLE FILE, and then skips to the next file.

Connecting a USB Flash Memory Device

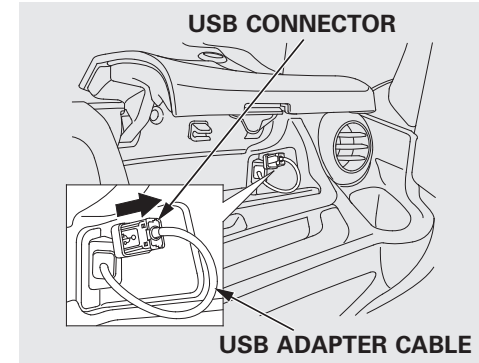

1. Open the upper glove box, and pull out the USB adapter cable.

Playing a USB Flash Memory Device (Models without navigation system)

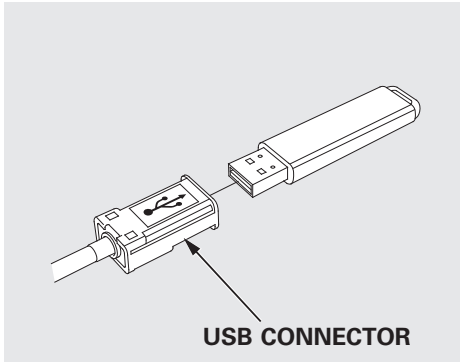

2. Connect the USB flash memory device to the USB connector correctly and securely.

When the USB flash memory device is connected, the USB indicator is shown in the display.



Text Data Display Function



Each time you press the TITLE button, the display mode shows you in sequence, the folder name, the file name, the artist name, the album name, the song name, or name off (which turns off the text display).



The display shows up to about 16 characters of the selected data. If the text data has more than 16 characters, you will see the first 15 characters and the ► indicator in the display. Press and hold the TITLE button until the next 16 characters are shown.

To Change or Select Files

Use the SKIP button while a USB flash memory device is playing to select passages and change files.

SKIP – Each time you press the  (SKIP +) button, the system skips forward to the beginning of the next file. Press the  (SKIP -) button, to skip backward to the beginning of the current file. Press it again to skip to the beginning of the previous file.

To move rapidly within a file, press and hold either side ( or ) of the SKIP button.

FOLDER SELECTION – To select a different folder, press the  button or  button. Press the  button to skip to the next folder, and press the  button to skip to the beginning of the previous folder.

CONTINUED

Playing a USB Flash Memory Device (Models without navigation system)

To Select a File from Folder and File Lists

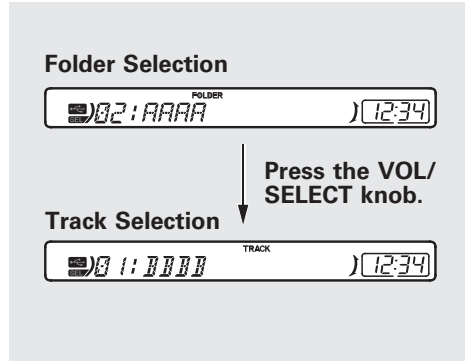

You can also select a folder or file by using the VOL/SELECT knob. Push the VOL/SELECT knob to switch the display to the folder or file list, then turn the VOL/SELECT knob to select a folder or file. Press the VOL/SELECT knob to set your selection.

Pressing the **▲ ↶** button goes back to the previous display and pressing the **TITLE** button cancels this setting mode.

To Select Repeat, Random or Scan Mode:

You can select any type of repeat, random and scan modes by using the RPT button or RDM button, or SCAN button.

REPEAT – This feature continuously plays a file. To activate the repeat feature, press the RPT button. You will see “RPT” in the display. To turn it off, press and hold the RPT button.

FOLDER REPEAT – This feature replays all the files in the selected folder in the order they are stored. To activate the folder repeat feature, press the RPT button repeatedly. You will see “F-RPT” in the display. To turn it off, press and hold the RPT button.

Each time you press the RPT button, the mode changes from file repeat to folder repeat, then to normal playing.

RANDOM – This feature plays all the files in random order. To activate the track random feature, press the RDM button. You will see “RDM” in the display. To turn it off, press and hold the RDM button.

FOLDER RANDOM – This feature plays the files in the selected folder in random order. To activate the folder random feature, press the RDM button repeatedly. You will see “F-RDM” in the display. To turn it off, press and hold the RDM button.

Each time you press the RDM button, the mode changes from track random play to folder random play, then to normal playing.

Playing a USB Flash Memory Device (Models without navigation system)

SCAN – This feature samples all files in the selected folder in the order they are stored. To activate the scan feature, press the SCAN button. You will see “SCAN” in the display. You will get a 10 second sampling of each file in the folder. Press and hold the SCAN button to get out of the scan mode and play the last file sampled.

FOLDER SCAN – This feature samples the first file in each folder in the order they are stored. To activate the folder scan feature, press the SCAN button repeatedly. You will see “F-SCAN” in the display. You will get a 10 second sampling of each first file in the folder(s). Press and hold the SCAN button to get out of the folder scan mode and play the last file sampled.

Each time you press the SCAN button, the mode changes from file scan to folder scan, then to normal playing.

To Stop Playing a USB Flash Memory Device

To play the radio when a USB flash memory device is playing, press the FM/AM button. If a disc is in the audio unit, press the CD button to play the disc.

Disconnecting a USB Flash Memory Device

You can disconnect the USB flash memory device in any time even if the USB mode is selected on the audio system. Always follow the USB flash memory device's instructions when you remove it.

When you disconnect the USB flash memory device while it is playing, the display shows “USB NO DATA.”

If you reconnect the same USB flash memory device, the system will begin playing where it left off.

USB Flash Memory Device Error Messages

If you see an error message in the display, see page 142.

USB Flash Memory Device Error Messages (Models without navigation system)

If you see an error message on the audio display while playing a USB flash memory device, find the solution in the chart to the right. If you cannot clear the error message, take your vehicle to your dealer.

Error Message	Solution
UNPLAYABLE FILE	The system cannot read the file(s). Check the files in the USB flash memory device. There is a possibility that the files have been damaged.
UNSUPPORTED	Appears when the unsupported USB flash memory device is inserted.

Playing the AM/FM Radio (Models with navigation system)

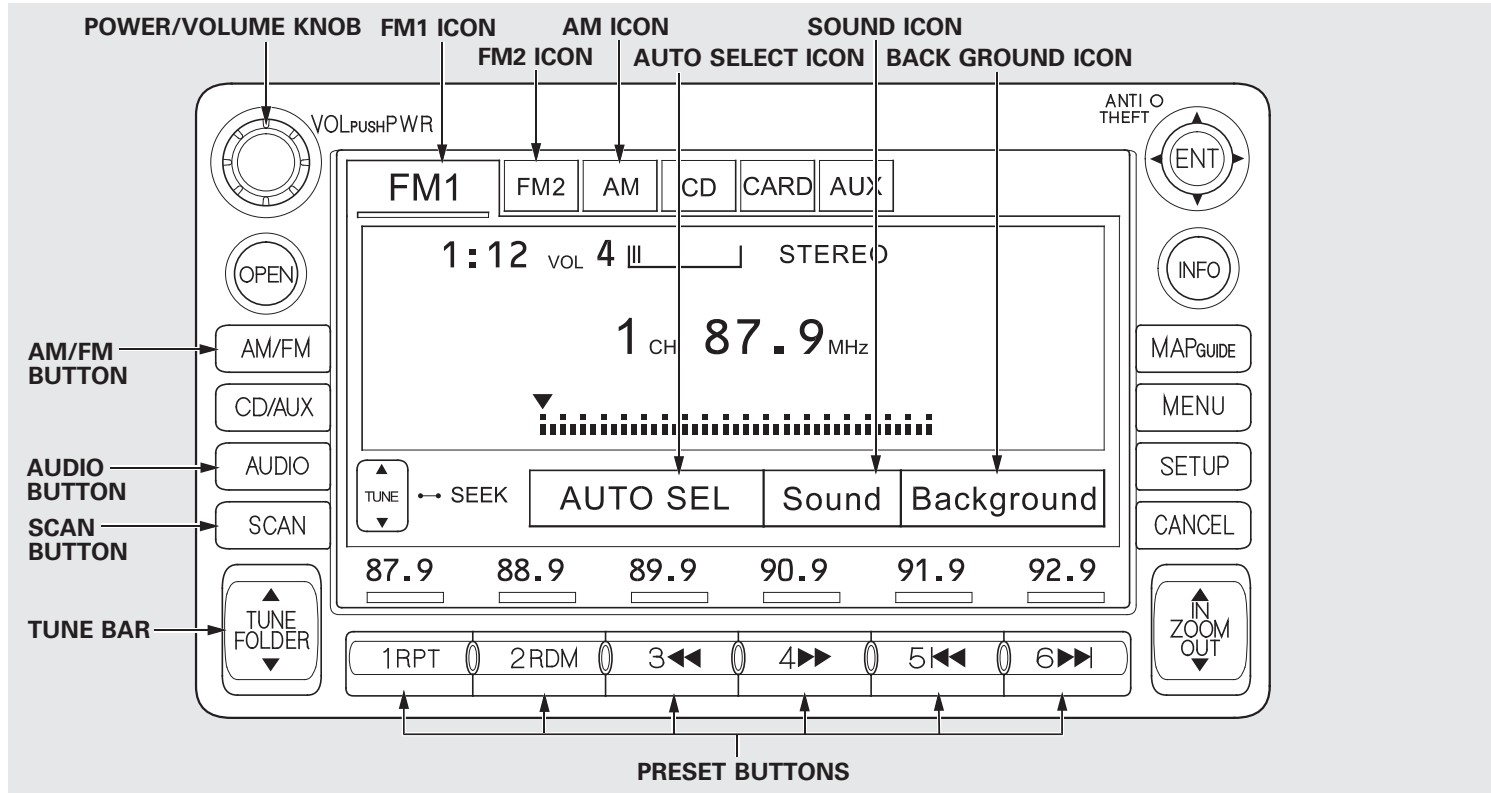

Features

CONTINUED

Playing the AM/FM Radio (Models with navigation system)

Voice Control System

In addition to the standard audio controls, the audio system in your vehicle can be operated using the voice control system. See the navigation system manual for complete details.

To Play the AM/FM Radio

The ignition switch must be in the ACCESSORY (I) or ON (II) position. Turn the system on by pushing the power/volume knob or the AM/FM button. Adjust the volume by turning the power/volume knob.

Pushing the AUDIO button will also turn on the system.

You can also operate the audio system without using the control icons on the audio screen. Use the control buttons on the left side of the screen. The status bar appears on the bottom of the screen each time you operate any of the control buttons. On the navigation screen, you can also see audio information by touching the AUDIO INFO icon on the lower of the screen.

The band and frequency that the radio was last turned to are displayed. To change bands, press the AM/FM button, or touch the desired band icon (FM1, FM2, or AM). On the FM band, STEREO will be displayed if the station is broadcasting in stereo. Stereo reproduction on AM is not available.

To Select a Station

You can use any of five methods to find radio stations on the selected band: tune, seek, scan, the preset buttons, and auto select.

TUNE – Use the TUNE bar to tune the radio to a desired frequency. Press the ▲ side of the bar to tune to a higher frequency, and press the ▼ side to tune to a lower frequency.

Press and hold the ▲ or ▼ side of the TUNE bar until you hear two beeps to change the frequency rapidly. Release the bar when the display reaches the desired frequency.

Playing the AM/FM Radio (Models with navigation system)

SEEK – The SEEK function searches up and down from the current frequency to find a station with a strong signal. To activate it, press and hold the ▲ or ▼ side of the TUNE bar until you hear a beep, then release it.

SCAN – The SCAN function samples all stations with strong signals on the selected band. To activate it, press the SCAN button, then release it. You will see SCAN in the display. The system will scan for a station with a strong signal. When it finds one, it will stop and play that station for about 10 seconds.

If you do nothing, the system will then scan for the next strong station and play it for 10 seconds. When it plays a station you want to listen to, press the SCAN button again.

Preset – Each preset button can store one frequency on AM and two frequencies on FM.

1. Select the desired band, AM or FM. FM1 and FM2 let you store two frequencies with each preset button.
2. Use the tune, seek, or scan function to tune the radio to a desired station.
3. Pick a preset button, and hold it until you hear a beep.
4. Repeat steps 1 through 3 to store a total of six stations on AM and twelve stations on FM.

Each preset button's frequency is shown on the bottom of the audio display.

CONTINUED

Playing the AM/FM Radio (Models with navigation system)

AUTO SELECT – If you are traveling far from home and can no longer receive your preset stations, you can use the auto select feature to find stations in the local area.

Press the AUDIO button to view the audio control icons, then touch the AUTO SEL icon. You will see AUTO SEL flashing in the display, and the system goes into scan mode for several seconds. It stores the frequencies of six AM, and twelve FM stations in the preset buttons.

You will see a “0” displayed after pressing a preset button if auto select cannot find a strong station for every preset button.

If you do not like the stations auto select has stored, you can store other frequencies on the preset buttons as previously described.

To turn off auto select, touch the AUTO SEL icon . This restores the presets you originally set.

For information on FM/AM radio frequencies and reception, see page 184.

Adjusting the Sound

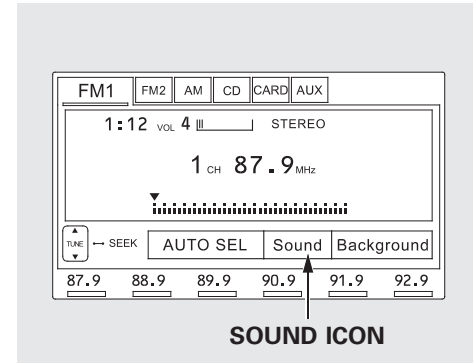

You can adjust the sound on the navigation screen. To adjust the sound, push the AUDIO button, then enter the sound grid by touching the SOUND icon on the display.

Playing the AM/FM Radio (Models with navigation system)

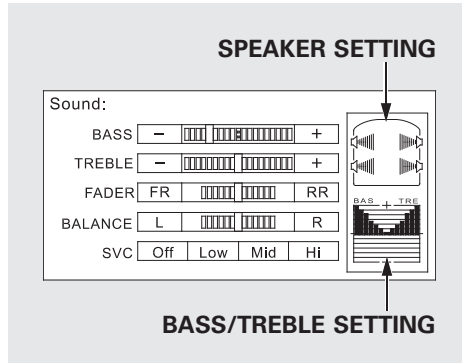

BASS – Adjusts the bass.

TREBLE – Adjusts the treble. To adjust the treble and bass, touch **+** or **-** on each side of the treble or bass adjustment bar. The adjustment bar on the right lower display shows you the current setting.

FADER – Adjusts the front-to-back strength of the sound. To adjust the front/rear fader, touch the FR or RR icon.

BALANCE – Adjusts the side-to-side strength of the sound. To adjust the left/right balance, touch the L or R icon.

The right upper display shows you the current setting of the sound strength coming from each speaker.

SVC (speed-sensitive volume compensation) – The SVC mode controls the volume based on vehicle speed. The faster you go, the louder the audio volume becomes. As you slow down, the audio volume decreases. Touch the appropriate icon (Low, Mid, Hi, Off) to select the mode.

This function is set to MID as the default setting when the vehicle leaves the factory. If you feel the sound is too loud, choose low. If you feel the sound is too quiet, choose Hi.

You can also select the icon with the joystick. Move it up and down to move the highlighting and scroll through lists. Select the icon, then enter the joystick.

The system will return to the audio display about 10 seconds after you stop adjusting a mode.

CONTINUED

Playing the AM/FM Radio (Models with navigation system)

Screen Mode

You can select the background screen to display the sound level. There are three screen modes: level (the sound level is shown with the vertical bars), spectrum analysis (the sound level appears as ripples of water), and off. Each time you touch the background icon, the display changes.

Audio System Lighting

You can use the instrument panel brightness control knob to adjust the illumination of the control panel (see page 76). The audio system illuminates when the parking lights are on, even if the radio is turned off.

Playing a Disc (Models with navigation system)

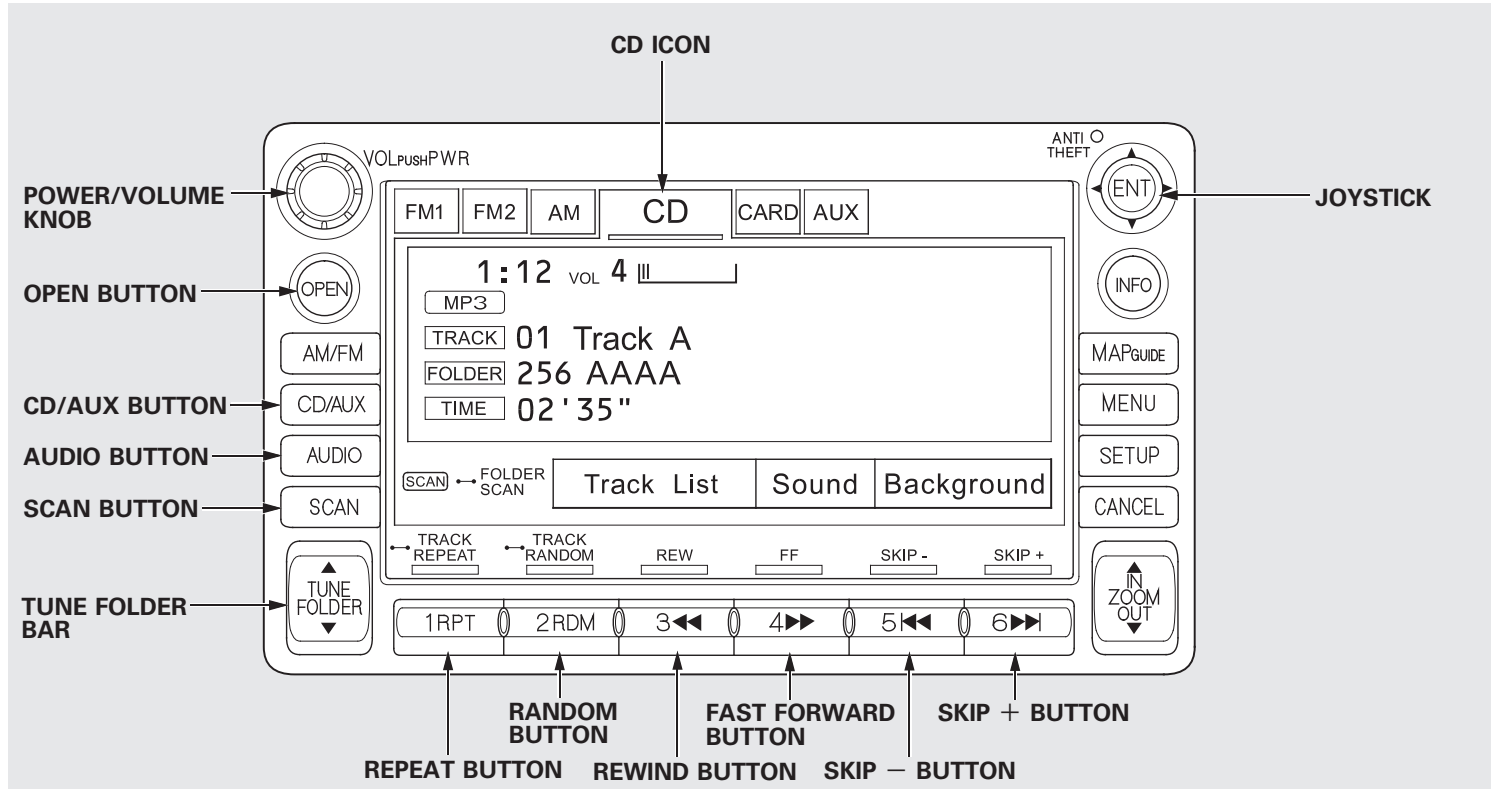

Features

CONTINUED

Playing a Disc (Models with navigation system)

To Play a Disc (In-dash single player)

You operate the in-dash disc player with the same controls used for the radio. To load or play discs, the ignition switch must be in the ACCESSORY (I) or ON (II) position.

NOTICE

Do not use discs with adhesive labels. The label can curl up and cause the disc to jam in the unit.

This audio system can also play CD-Rs and CD-RWs compressed in MP3 or WMA formats. When playing a disc in MP3, you will see “MP3” on the screen. In WMA format, “WMA” will appear on the screen. You can select up to 255 folders and play up to 999 tracks. If the disc has a complex structure, it takes a while to read the disc before the system begins to play it.

If you have a disc that is a combination of CD-DA tracks and MP3/WMA files, you can choose the format to listen by pressing and holding CD/AUX button until you hear a beep.

Video CDs and DVD discs do not work in this unit.

A disc compressed in AAC format cannot be played in this audio system.

The specifications for compatible MP3 files are:

- Sampling frequency:
32/44.1/48 kHz (MPEG1)
24/22.05/16 kHz (MPEG2)
- Bit rate:
32/40/48/56/64/80/96/112/128/
160/192/224/256/320 kbps
(MPEG1)
8/16/24/32/40/48/56/64/80/96/
112/128/160 kbps (MPEG2)
- Compatible with variable bit rate
and multi-session

- Maximum layers
(including ROOT): 8 layers

The specifications for compatible WMA files are:

- Sampling frequency:
32/44.1/48 kHz
- Bit rate:
32/40/48/64/80/96/128/160/192
kbps
- Compatible with variable bit rate
and multi-session
- Maximum layers
(including ROOT): 8 layers

NOTE:

If a file on an MP3 or WMA disc is protected by digital rights management (DRM), the audio unit displays FILE ERROR, and then skips to the next file.

Playing a Disc (Models with navigation system)

To Load a Disc

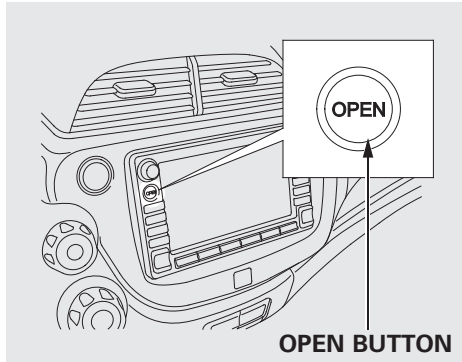

The in-dash disc player is behind the navigation screen. To use the disc player, press the OPEN button beside the screen. The screen folds back, and the disc slot appears.

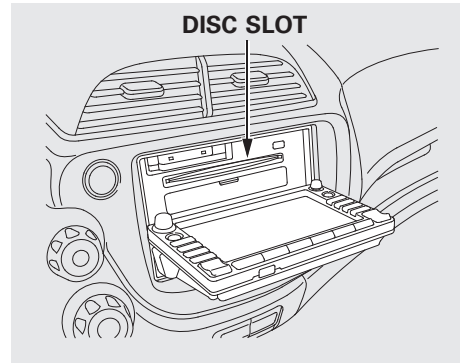

Insert a disc about halfway into the disc slot. The drive will pull the disc in the rest of the way and begin to play it.

You cannot load and play 3-inch (8-cm) discs in this system.

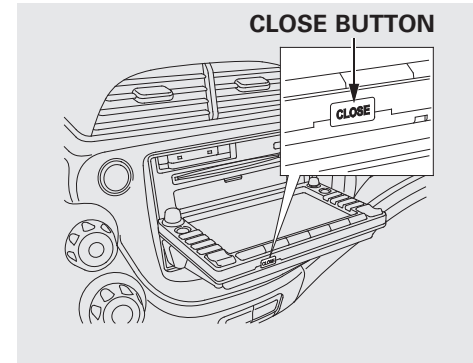

To return the screen to the upright position, press the CLOSE button on the edge of the screen panel. Do not use the folded screen as a tray. If you put a cup, for example, on the screen, the liquid inside the cup may spill on the screen when you go over a bump.

Playing a Disc (Models with navigation system)

Press the AUDIO button beside the screen to show the audio display and operate the in-dash disc player.

You can also operate the audio system without using the control icons on the audio screen. Press the CD/AUX button. The status bar appears on the bottom of the screen. On the navigation screen, you can see the audio information whenever you touch the AUDIO INFO or TRACK LIST icons on the lower of the screen.

When playing a CD recorded with text data, the track, album, and artist name are shown on the audio display. When playing a disc in MP3 or WMA, the folder number and name, the file number and name, the artist name, and the elapsed time are shown. The system will continuously play a disc until you change modes. If the disc was not recorded with text data, it will not be displayed.

To Change or Select Tracks/Files

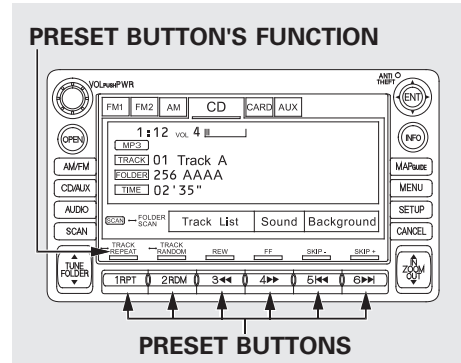

You can use the preset buttons while a disc is playing to select passages and change tracks (files in MP3 or WMA mode). Each preset button's function is shown on the bottom of the screen.

You can also select an icon with the joystick. Move it to left, right, up, or down to change the highlighting and scroll through lists. Then press the ENT on the top of the joystick to select the icon.

SKIP – Each time you press ►► (preset 6), the player skips forward to the beginning of the next track (file in MP3 or WMA mode). Press ◄◄ (preset 5), to skip backward to the beginning of the current track. Press it again to skip to the beginning of the previous track.

FF/REW – To move rapidly within a track/file, press and hold ►► (preset 4) or ◄◄ (preset 3).

Playing a Disc (Models with navigation system)

In MP3 or WMA mode

FOLDER SELECTION – To select a different folder, press either side of the TUNE FOLDER bar to move to the beginning of the next folder. Press the ▲ side of the TUNE FOLDER bar to skip to the next folder, and the ▼ side to move to the beginning of the current folder. Press it again to skip to the beginning of the previous folder.

TRACK REPEAT (FILE REPEAT)

– To continuously replay a track (file in MP3 or WMA mode), press the RPT button (preset 1). You will see “TRACK REPEAT” in the display. Press the RPT button again to turn it off.

In MP3 or WMA mode

FOLDER REPEAT – This feature, when activated, replays all files on the selected folder in the order they are compressed. To activate folder repeat, press and hold the RPT button (preset 1) for 2 seconds. You will see “FOLDER REPEAT” in the display. The system continuously replays the current folder. Press the RPT button again to turn it off. Selecting a different folder with the TUNE FOLDER bar also turns off folder repeat.

TRACK RANDOM (Random within a disc/folder) – This feature plays the tracks/files within a disc in random order. To activate track random, press the RDM button (preset 2). You will see “TRACK RANDOM” in the display. Press the RDM button again to return to normal play.

In MP3 or WMA mode

FOLDER RANDOM – This feature, when activated, plays all files in the selected folder in random order, rather than in the order they are compressed. To activate folder random, press and hold the RDM button. You will see “FOLDER RANDOM” in the display. The system then selects and plays files randomly. This continues until you deactivate folder random by pressing the RDM button again, or if you select a different folder with the TUNE FOLDER bar.

CONTINUED

Playing a Disc (Models with navigation system)

SCAN (TRACK/FILE SCAN) –

The scan function samples all tracks (files in MP3 or WMA) in the order they were recorded. To activate scan, press the SCAN button. You will see “TRACK SCAN” in the display. You will get a 10 second sampling of each track/file on the disc. Press the SCAN button to get out of scan mode and play the last track/file sampled.

Pressing either SKIP button (preset 5 or 6) also turns off scan.

In MP3 or WMA mode

FOLDER SCAN – This feature, when activated, samples all the first files in each folder on the disc in order. To activate folder scan, press and hold the SCAN button for 2 seconds. You will see “FOLDER SCAN” in the display.

The system plays the first file in each folder for about 10 seconds. If you do nothing, the system then plays the first file in each folder for 10 seconds each. After playing the first file of the last folder, the system goes to normal playing.

Pressing either SKIP button (preset 5 or 6), or selecting a different folder with the TUNE FOLDER bar, or pressing the SCAN button, also turns off folder scan.

Using a Track List

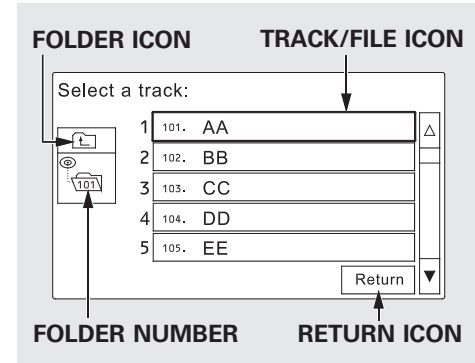

You can also select a track/file directly from a track list on the audio display. Press the AUDIO button to show the audio display, then touch the Track List icon. The track list menu appears on the display.

Playing a Disc (Models with navigation system)

When playing a CD recorded with text data, each track name is shown on the audio display. With a disc recorded in MP3 or WMA, the folder number and the location are also displayed.

If the disc was not recorded with text data, only the track number is shown.

To scroll through the display, touch the ▲ or ▼ icon on the side of the screen. To go back to the previous display, touch the Return icon on the screen.

Select the desired track/file by touching the icon on the display. The selected icon will be highlighted in blue. The system begins to play the selected track/file. With a disc in MP3 or WMA, touch the folder icon on the upper left of the screen to move to the root folder. The current folder is highlighted in blue.

To Stop Playing a Disc

To play the radio when a disc is playing, press the AM/FM button or touch the FM1, FM2, or AM icon. If a PC card is in the audio unit, touch the CARD icon to play the PC card. Press the CD/AUX button again or touch the CD icon to switch back to the in-dash disc player.

If you turn the system off while a disc is playing, either with the power/volume knob or by turning off the ignition switch, the disc will stay in the drive. When you turn the system back on, the disc will begin playing where it left off.

CONTINUED

Playing a Disc (Models with navigation system)

Removing a Disc

To remove a disc from the audio unit, fold back the screen by pressing the OPEN button (see page 150). Press the disc eject button (▲) to remove the disc. If you eject the disc, but do not remove it from the slot, the system will automatically reload it after 10 seconds and put it in pause mode. To begin playing, press the CD/AUX button.

To return the screen to the upright position, press the CLOSE button.

You cannot close the screen if a disc is partially inserted into its slot.

You can also eject the disc when the ignition switch is off.

Protecting Discs

For information on how to handle and protect discs, see page 186.

Disc Player Error Messages (Models with navigation system)

If you see an error message in the display while playing a disc, find the cause in the chart to the right. If you cannot clear the error message, take your vehicle to your dealer.

The chart on the right explains the error messages you may see in the display while playing a disc.

If you see an error message in the display while playing a disc, press the eject button. After ejecting the disc, check it for damage or deformation. If there is no damage, insert the disc again.

The audio system will try to play the disc. If there is still a problem, the error message will reappear. Press the eject button, and pull out the disc.

Insert a different disc. If the new disc plays, there is a problem with the first disc. If the error message cycle repeats and you cannot clear it, take your vehicle to a dealer.

Error Message	Cause	Solution
CHECK DISC	FOCUS Error	Press the eject button, and pull out the disc. Check if it is inserted correctly in the disc player. Make sure the disc is not scratched or damaged.
MECH ERROR	Mechanical Error	Press the eject button, and pull out the disc. Check the disc for damage or deformation. If the disc cannot be pulled out, or the error message does not disappear after the disc is ejected, see your dealer.
CHECK DISC	Disc Format Error	Press the eject button, and pull out the disc. Check the disc for damage or deformation.
HEAT ERROR	High Temperature	Will disappear when the temperature returns to normal.

Playing a PC card (Models with navigation system)

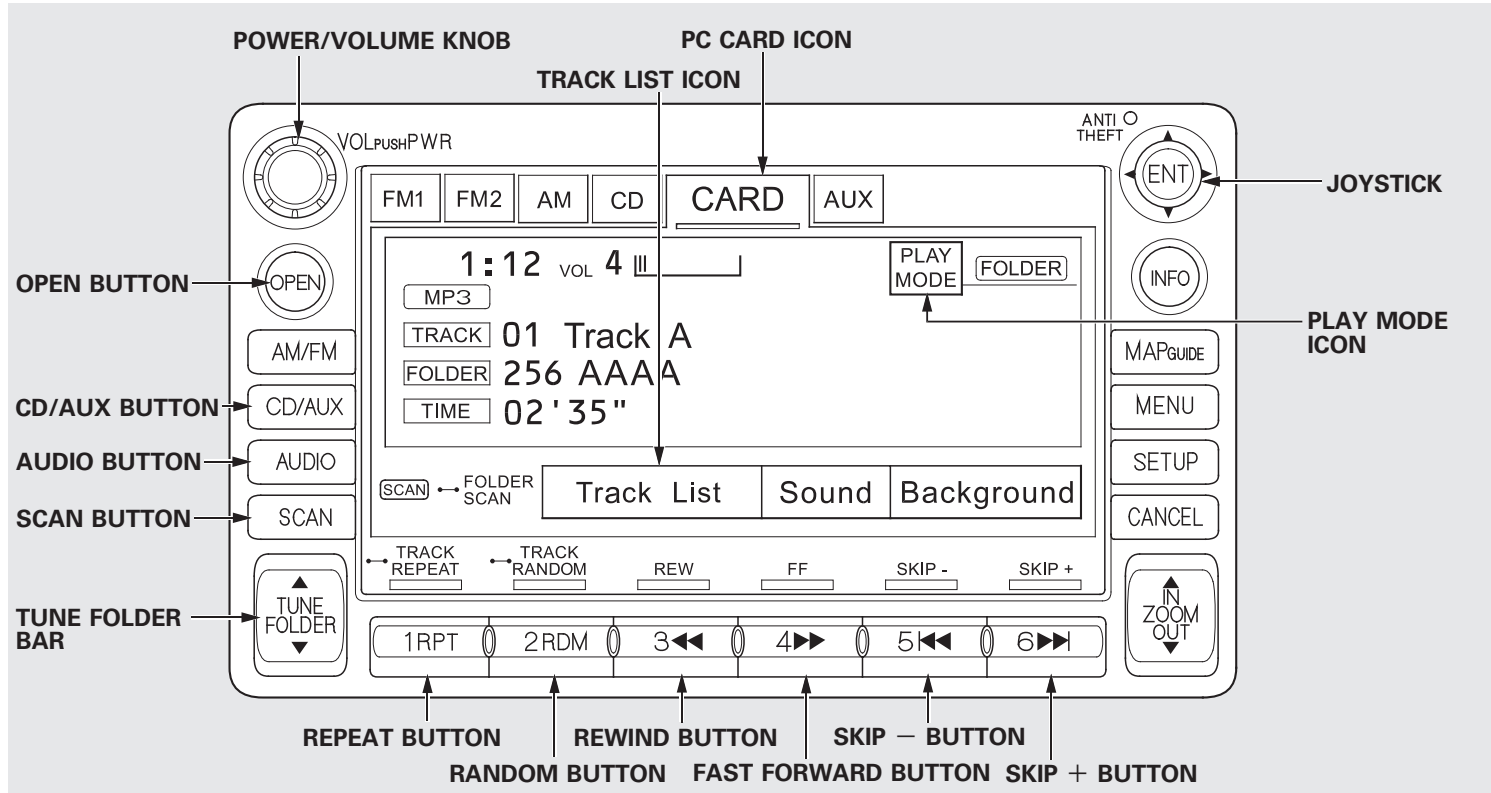

Playing a PC card (Models with navigation system)

To Play a PC card

You operate the PC card player with the same controls used for the radio and the in-dash disc player. To load or play a card, the ignition switch must be in the ACCESSORY (I) or ON (II) position.

The PC card player reads and plays cards in MP3 or WMA formats. Depending on the format, the screen will indicate “MP3” or “WMA” when a card is playing. The card limit of the player is 255 folders and 999 tracks. If the card has a complex structure, it takes some time for the system to begin playing it.

Based on PCMCIA 2.1/JEIDA 4.2, the recommended PC cards for the PC card reader are:

CompactFlash
Flash ATA

SD memory card

Always use the recommended memory card with the appropriate adapter (if an adapter is needed). Some memory cards will not work in this unit.

NOTE:

- When you insert a PC card into the slot, make sure you put it in straight. If you cannot insert it, remove it, and insert again.
- Do not keep PC cards in the vehicle. Direct sunlight and high heat will damage them.
- To avoid damaging the card reader, do not insert hard disc drive cards into the PC card slot.
- You cannot close the screen (move it to the upright position) until the PC card is inserted all the way into its slot or removed.

- Never insert foreign objects into the PC card slot.

The specifications for compatible MP3 files are:

- Sampling frequency:
32/44.1/48 kHz (MPEG1)
24/22.05/16 kHz (MPEG2)
- Bit rate:
32/40/48/56/64/80/96/112/128/
160/192/224/256/320 kbps
(MPEG1)
8/16/24/32/40/48/56/64/80/96/
112/128/160 kbps (MPEG2)
- Compatible with variable bit rate and multi-session
- Maximum layers
(including ROOT): 8 layers

CONTINUED

Playing a PC card (Models with navigation system)

The specifications for compatible WMA files are:

- Sampling frequency:
32/44.1/48 kHz
- Bit rate:
48/64/80/96/128/160/192 kbps
- Compatible with variable bit rate and multi-session
- Maximum layers
(including ROOT): 8 layers

In WMA format, DRM (digital rights management) files cannot be played. If the system finds a DRM file, it skips that file and plays the next available folder or file.

Loading a PC Card

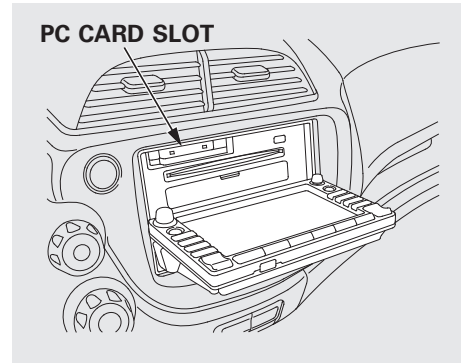

The PC card slot is behind the navigation screen. To use the PC card player, press the OPEN button beside the screen. The screen folds back, and the PC card slot appears.

Insert a PC card straight into the slot. The drive will read the PC card and begin to play it.

Return the screen to the upright position by pressing the CLOSE button on the edge of the screen panel.

Press the AUDIO button beside the screen to show the audio display and operate the PC card player.

You can also operate the audio system without using the control icons on the audio screen. Press any of the appropriate control buttons. The status bar appears on the bottom of the screen. On the navigation screen, you can see the audio information whenever you touch the AUDIO INFO icon on the screen.

Playing a PC card (Models with navigation system)

There are three play modes: Folder, Artist, and Album. Touch the PLAY MODE icon, then choose one of the modes by touching its icon. When a mode is selected, it is highlighted in blue.

- Folder mode plays tracks in the order they were added to the card.
- Artist mode plays tracks in alphabetical order, by artist and song title.
- Album mode plays albums (folders) in alphabetical order.

If play mode information was not included in the tracks/files when they were added to the card, it will not be displayed on the screen.

To Select a Play Mode

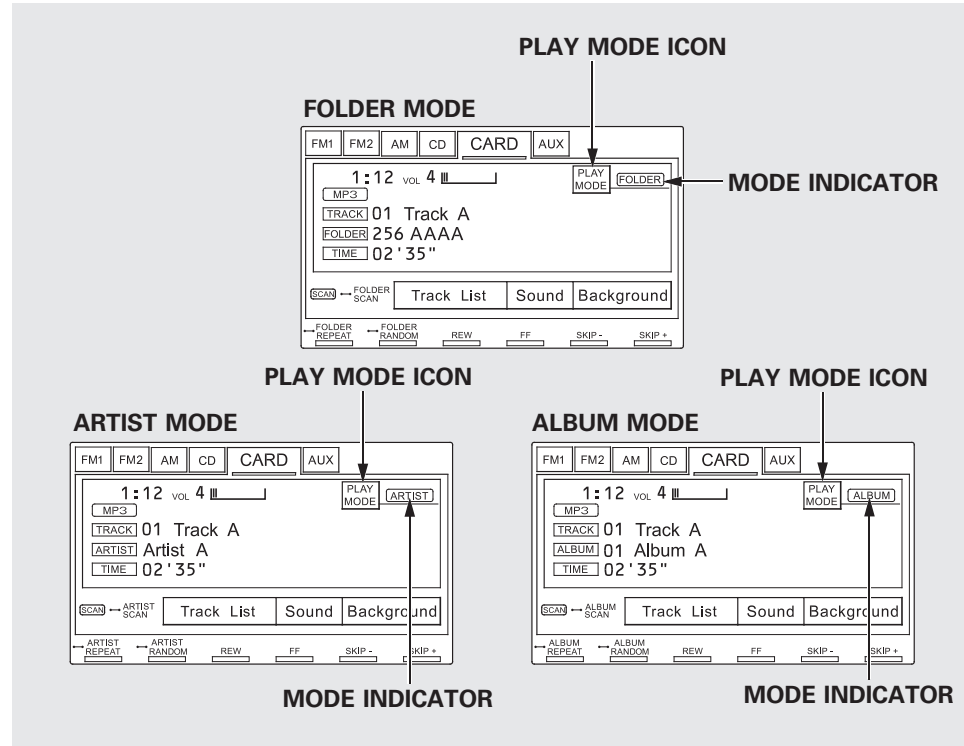

CONTINUED

Playing a PC card (Models with navigation system)

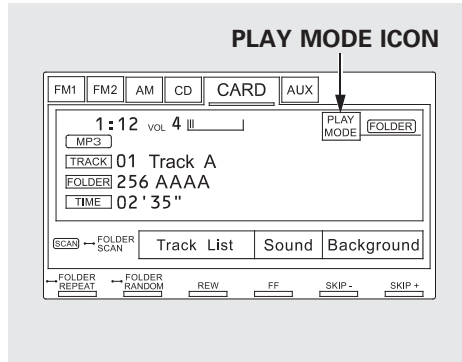

To select a play mode, push the AUDIO button to show the audio display, then touch the PLAY MODE icon on the display.

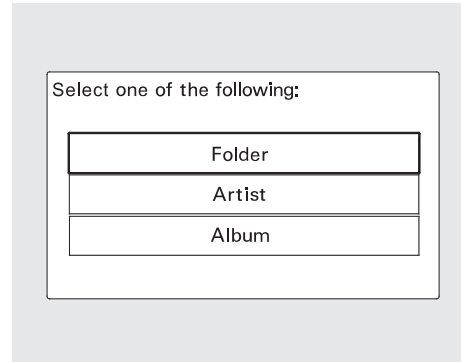

Select the desired mode by touching the appropriate icon, or move the joystick, then press the ENT.

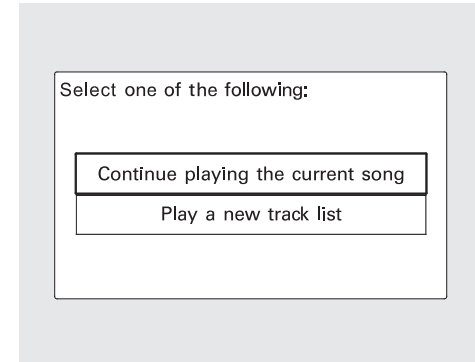

After you select the play mode, the display changes to the selectable playing menu. If you select "Continue playing the current song," the system goes into the selected play mode after playing the current file.

Playing a PC card (Models with navigation system)

If you select “Play a new track list,” the system goes into the selected play mode immediately and begins to play the new track list.

To go back to the previous screen, press the CANCEL button on the right side of the screen. To exit the play mode screens, press the AUDIO button.

To Change or Select Tracks/Files

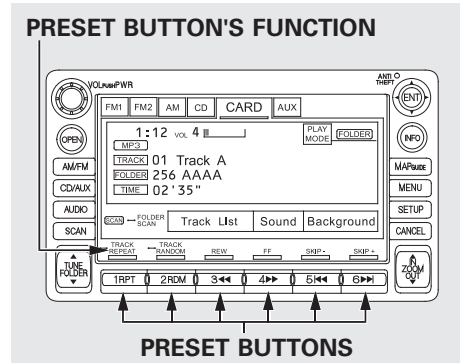

You can use the preset buttons while a card is playing to select or change files. Each preset button's function is shown on the bottom of the screen.

Icons on the screen can also be selected with the joystick. Move the joystick left or right and up or down until the icon is highlighted, then press the ENT on the top of the joystick to select the icon.

CONTINUED

Playing a PC card (Models with navigation system)

SKIP – Each time you press ►► (preset 6), the player skips forward to the beginning of the next file. Press ◀◀ (preset 5), to skip backward to the beginning of the current file. Press it again to skip to the beginning of the previous file.

FF/REW – To move rapidly within a file, press and hold ►► (preset 4) or ◀◀ (preset 3).

FOLDER SELECTION – To select a different folder, press either side of the TUNE FOLDER bar to move the beginning of the next folder. Press the ▲ side of the TUNE FOLDER bar to skip the next folder, and to the ▼ side to move the beginning of the current folder. Press it again to skip to the beginning of the previous folder.

TRACK REPEAT (FILE REPEAT)

– To continuously replay a file, press the RPT button (preset 1). You will see “TRACK REPEAT” in the display. Press the RPT button again to turn it off.

FOLDER/ARTIST/ALBUM

REPEAT – This feature, when activated, replays all the files on the selected folder/artist/album in the order they are recorded or listed. To activate each repeat mode, press and hold the RPT button (preset 1) for 2 seconds. You will see “FOLDER REPEAT, ARTIST REPEAT or ALBUM REPEAT” in the display. The system continuously replays the current folder/artist/album. Press and hold the RPT button again to turn it off. Pressing the RDM button, or selecting a different folder/artist/album with the TUNE FOLDER bar also turns off the repeat feature.

TRACK RANDOM (Random

within a folder) – This feature plays the files within a folder in random order. To activate random play, press the RDM button (preset 2). You will see “TRACK RANDOM” in the display. Press the RDM button again to return to normal play.

FOLDER/ARTIST/ALBUM

RANDOM – This feature, when activated, plays all files in each folder/artist/album in random order, rather than in the order they are recorded or listed. To activate each random play, push and hold the RDM button (preset 2) for 2 seconds. You will see “FOLDER RANDOM, ARTIST RANDOM or ALBUM RANDOM” in the display.

Playing a PC card (Models with navigation system)

The system then selects and plays files randomly. This continues until you deactivate each random play by pressing the RDM button again.

SCAN – The SCAN function samples all the files on the PC card in the order they are recorded. To activate the scan feature, press the SCAN button. You will see “TRACK SCAN” in the display. You will get a 10 second sampling of each file on the PC card. Press the SCAN button again to get out of scan mode and play the last file sampled.

Pressing either of the SKIP buttons (preset 5 or 6) also turns off the scan feature.

FOLDER/ARTIST/ALBUM SCAN

– This feature, when activated, samples the first file in each folder/artist/album on the PC card in order. To activate each scan feature, press and hold the SCAN button. You will see “FOLDER SCAN, ARTIST SCAN or ALBUM SCAN” in the display.

The system plays the first file in the folder for about 10 seconds. If you do nothing, the system plays the first file in each folder, in order, for 10 seconds each. After playing the first file of the last folder/artist/album, the system returns to normal play.

Pressing either of the SKIP buttons (preset 5 or 6), selecting a different folder/artist/album with the TUNE FOLDER bar, or pressing the SCAN button, also turns off the scan feature.

CONTINUED

Playing a PC card (Models with navigation system)

Using a Track List

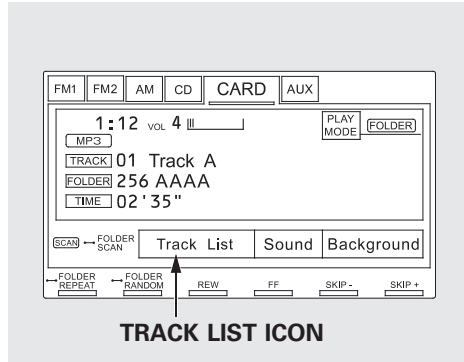

You can also select a file directly from a track list on the audio display. Press the AUDIO button to show the audio display, then touch the Track List icon. The track list menu appears on the display.

FOLDER ICON

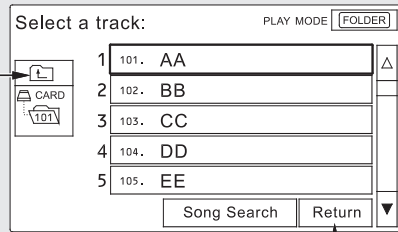

To scroll through the display, touch the ▲ or ▼ icon on the side of the screen. To go back to the previous display, touch the Return icon.

To play a file, touch its icon on the screen. In folder mode, touch the folder icon on the upper left of the screen to move to the root folder. The current folder is highlighted in blue.

ARTIST NAME

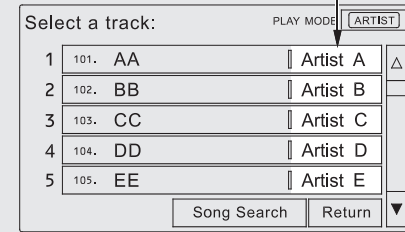

In artist mode, the artist name is also displayed on the right side of each selectable icon. Select the desired file.

Playing a PC card (Models with navigation system)

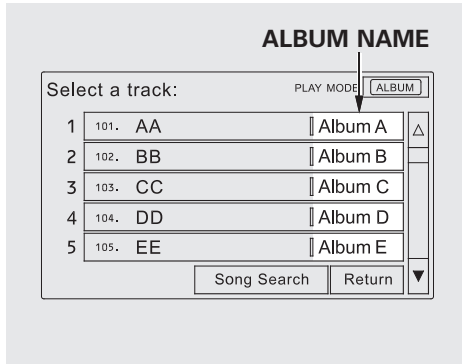

In album mode, the album name is also displayed on the right side of each selectable icon. Select the desired file.

Song Search Function

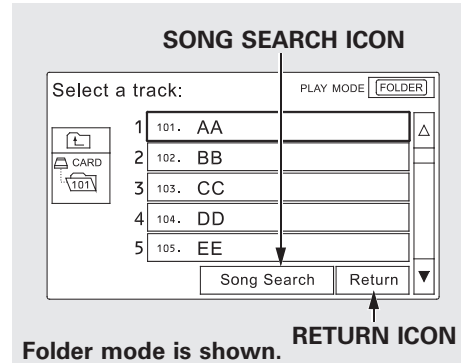

Folder mode is shown. When you select “Song Search” from the track list display, the song search menu appears.

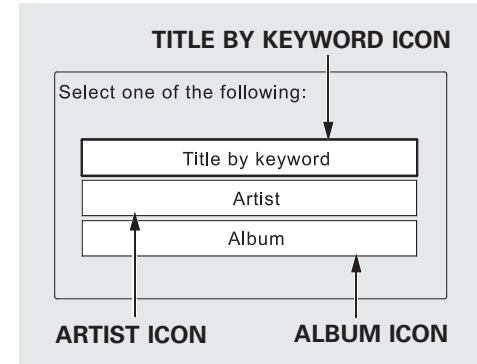

You can then select any of three modes to search a file: Title by keyword, Artist, and Album.

Playing a PC card (Models with navigation system)

Searching for a Song Title by keyword

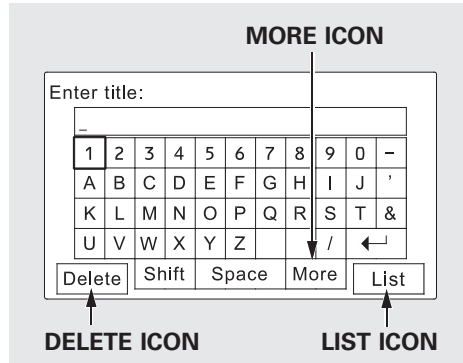

In Title by keyword mode, enter the title name, or any keyword, by touching the letter icons on the screen. Press the List icon to begin the song search. If you press the CANCEL button on the control panel, the display returns to the mode menu without doing a search.

To cancel the selected letter, touch the Delete icon. To select more characters, touch the More icon. The other character list will be shown.

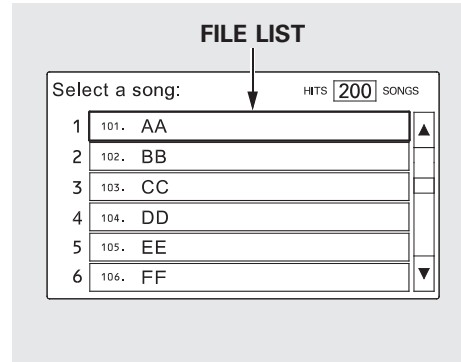

After the system searches for a song, a file list is displayed. To scroll through the list, touch the ▲ or ▼ icon on the side of the screen. Select the desired file by touching the appropriate icon, or moving the joystick and pressing the ENT.

Searching for a Song by Artist Name

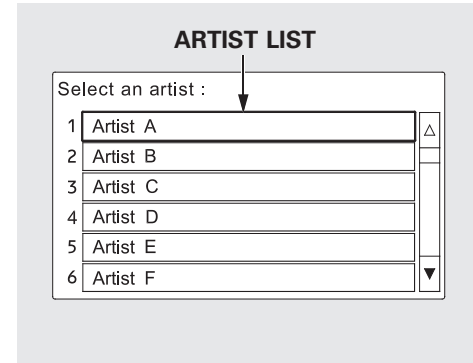

Select the Artist icon, and the artist list appears. Select the desired artist, and the artist's file list is displayed.

Playing a PC card (Models with navigation system)

Searching for a Song by Album Name

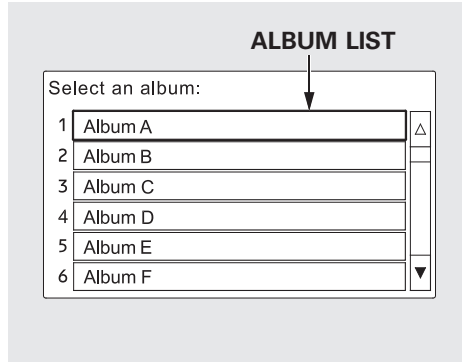

Select the Album icon, and the album list appears. Select the desired album, and its song list is displayed. You can then select the desired song from the list.

To Stop Playing a PC card

To play the radio when a PC card is playing, press the AM/FM button or touch the FM1, FM2, or AM icon. If a disc is in the audio unit, press the CD/AUX button or touch the CD icon to play the disc. Touch the CARD icon to switch back to the PC card player.

If you turn the system off while a PC card is playing, either with the power/volume knob or by turning off the ignition switch, the card will stay in the drive. When you turn the system back on, the card will begin playing where it left off.

When you leave the vehicle, always remove the PC card from the audio unit.

Removing a PC Card

To remove a PC card from the audio unit, fold back the screen by pressing the OPEN button (see page 150). Press the eject button (▲) to remove the card. If you do not remove it from the slot, you cannot return the screen to the upright position.

To return the screen to the upright position, press the CLOSE button.

You can also eject a card when the ignition switch is off.

PC Card Player Malfunction

If there is a problem with the PC card player, see your dealer.

Playing an iPod® (Models with navigation system)

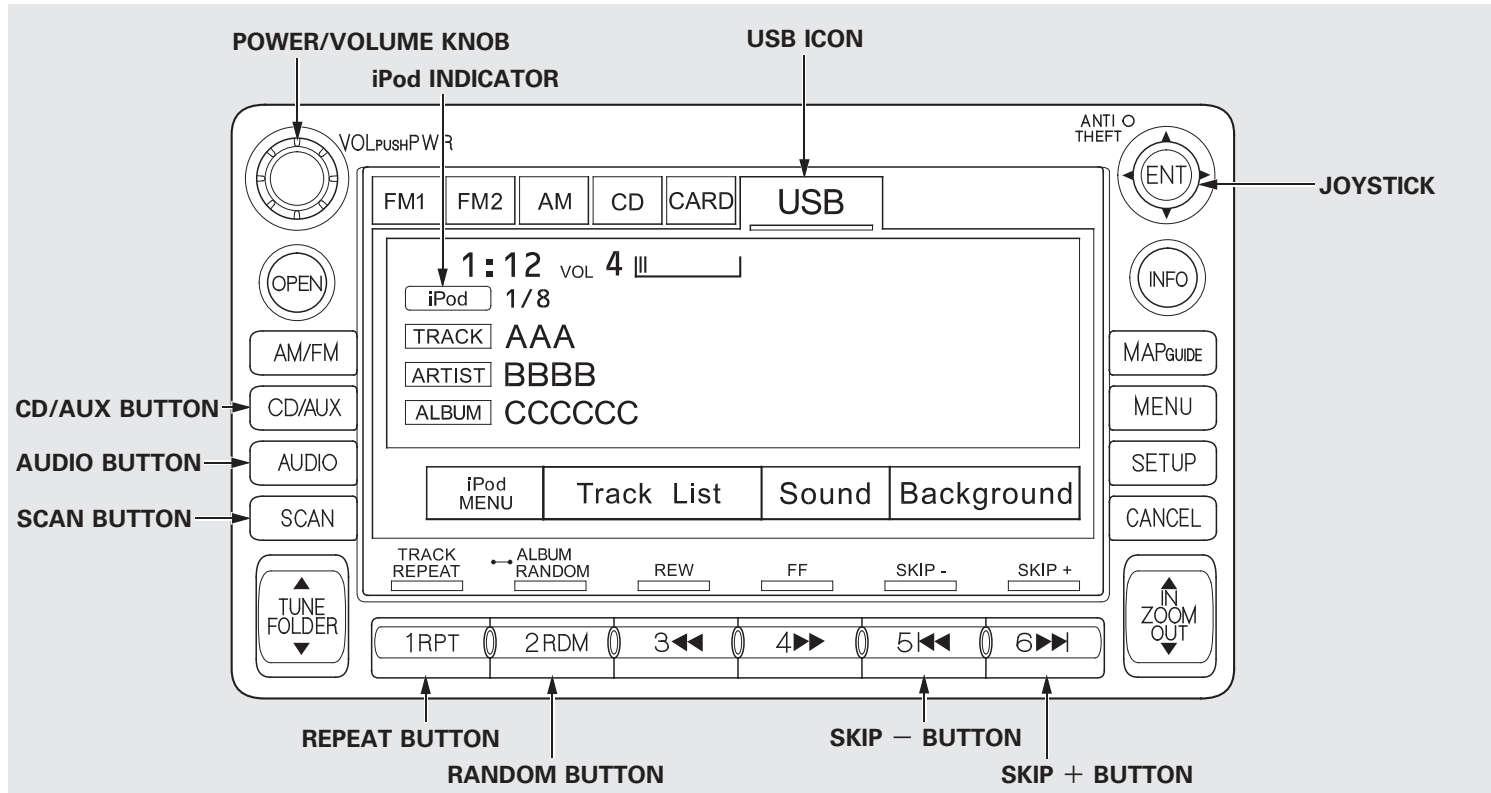

Playing an iPod® (Models with navigation system)

To Play an iPod®

This audio system can operate the audio files on the iPod® with the same controls used for the in-dash disc player. To play an iPod, connect it to the USB adapter cable in the upper glove box by using your dock connector, then press the CD/AUX button. The ignition switch must be in the ACCESSORY (I) or ON (II) position. The iPod will also be recharged with the ignition switch in these positions.

The audio system reads and plays sound files to be playable on the iPod. The system cannot operate an iPod as a mass storage device. The system will only play songs stored on the iPod with iTunes.

iPod and iTunes are registered trademarks owned by Apple Inc.

Voice Control System

You can select the AUX mode by using the navigation system voice control buttons, but cannot operate the play mode functions.

iPods compatible with your audio system using the USB adapter cable are:

Model	Software
iPod classic	Ver. 1.0 or more
iPod with video (iPod 5th generation)	Ver. 1.2 or more
iPod nano	Ver. 1.2 or more
iPod nano 2nd generation	Ver. 1.1.2 or more
iPod nano 3rd generation	Ver. 1.0 or more
iPod touch	Ver. 1.1.1 or more

Use only compatible iPods with the latest software. iPods that are not compatible will not work in this audio unit.

NOTE:

- Do not connect your iPod using a HUB.
- Do not keep the iPod in the vehicle. Direct sunlight and high heat will damage it.
- Do not use an extension cable between the USB adapter cable equipped with your vehicle and your dock connector.
- We recommend backing up your data before playing it.

In AAC format, DRM (digital rights management) files cannot be played. If the system finds a DRM file, the audio unit displays UNPLAYABLE, and then skips to the next file.

CONTINUED

Playing an iPod® (Models with navigation system)

Connecting an iPod

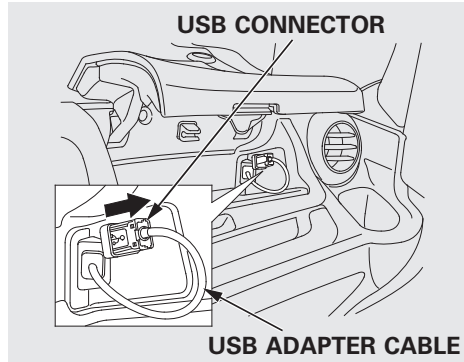

1. Open the upper glove box, and pull out the USB adapter cable.

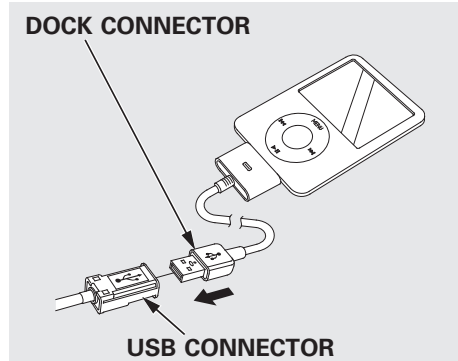

2. Connect your dock connector to the iPod correctly and securely.
3. Install the dock connector to the USB connector securely.

If the audio system still does not recognize the iPod, the iPod may need to be reset. Follow the instructions that came with your iPod, or you can find reset instructions online at www.apple.com/ipod.

The current file number and total of the selected playable files are displayed on the screen. It also shows the artist, album and track (file) names on the screen.

Playing an iPod® (Models with navigation system)

To Change or Select Files

Use the SKIP button while an iPod is playing to select passages and change files.

SKIP – Each time you press the SKIP + button (Preset 6), the system skips forward to the beginning of the next file. Press the SKIP – button (Preset 5), to skip backward to the beginning of the current file. Press it again to skip to the beginning of the previous file.

To Select a File from iPod Menu

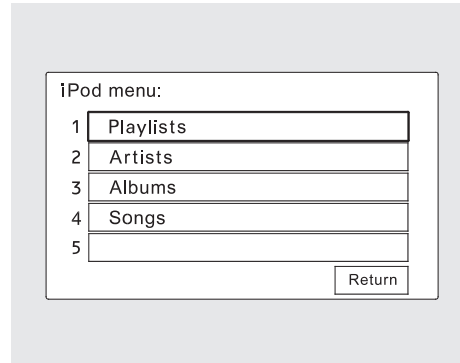

You can also select a file from any on the iPod menu: playlists, artists, albums and songs. Press the AUDIO button to display the screen, then touch the iPod MENU icon.

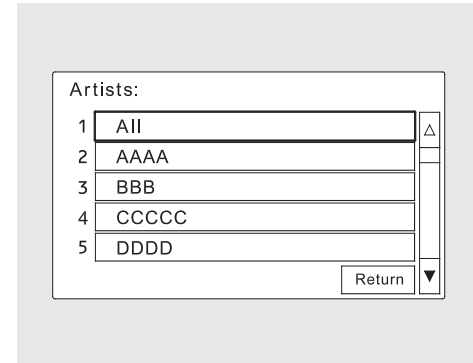

Select the desired mode by touching the appropriate icon, or move the joystick, then press the ENT.

If you select “ALL” on either the artists or albums list, all available files on the selected list are played.

Press the AUDIO button to go back to the normal audio playing display. Pressing the CANCEL button goes back to the previous screen, and pressing the MAP button cancels the audio control display on the screen.

CONTINUED

Playing an iPod® (Models with navigation system)

Using a Track List

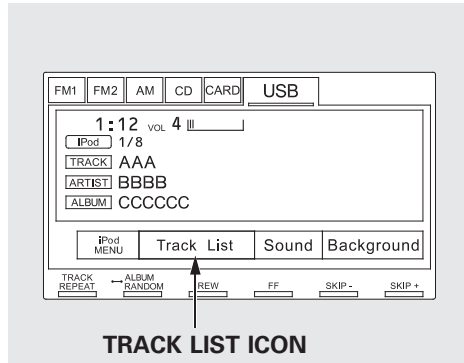

You can also select a file directly from a track list on the audio display. Press the AUDIO button to show the audio display, then touch the Track List icon. The track list menu appears on the display.

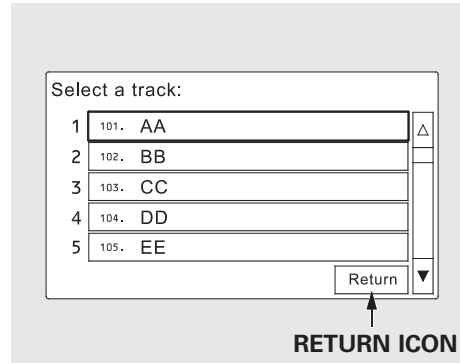

To scroll through the display, touch the ▲ or ▼ icon on the side of the screen. To go back to the previous display, touch the Return icon.

To play a file, touch its icon on the screen. The current folder is highlighted in blue.

To Select Repeat or Random Mode:

You can select any type of repeat and random mode by using the RPT button or RDM button.

REPEAT – This feature continuously plays a file. To activate the repeat feature, press the RPT button (Preset 1). You will see “REPEAT” in the display. To turn it off, press the RPT button (Preset 1) again.

TRACK RANDOM – This feature plays all available files from the selected items in the iPod menu list (playlists, artists, albums or songs) in random order. To activate the track random feature, press the RDM button (Preset 2). You will see “TRACK RANDOM” in the display. To turn it off, press the RDM button (Preset 2).

Playing an iPod® (Models with navigation system)

ALBUM RANDOM – This feature plays all available albums from the selected items in the iPod menu list (playlists, artists, albums or songs) in random order. The files in each album are played in the recorded order. To activate the album random feature, press and hold the RDM button (Preset 2). You will see “ALBUM RANDOM” in the display. To turn it off, press and hold the RDM button (Preset 2).

You can also select another list from the iPod menu while keeping the random function.

NOTE:

Available operating function varies on models or versions. Some functions may not be available on the vehicle's audio system.

To Stop Playing Your iPod

To play the radio when an iPod is playing, press the FM/AM button or touch the FM1, FM2, or AM icon. If a disc is in the audio unit, press the CD/AUX button or touch the CD icon to play the disc. If a PC card is in the audio unit, Press the CD/AUX button or touch the CARD icon to play a PC card.

Press the CD/AUX button again or touch the AUX icon to switch back to the iPod.

Disconnecting an iPod

You can disconnect the iPod at any time when you see “OK to Disconnect” message* in the iPod display. Always make sure you see “OK to Disconnect” message in the iPod display before you disconnect it. Make sure to follow the iPod's instructions on how to disconnect the dock connector from the USB adapter cable.

*: The displayed message may vary on models or versions. On some models, there is no message to disconnect.

When you disconnect the iPod while it is playing, the navigation screen shows “NO DATA.”

If you reconnect the same iPod, the system may begin playing where it left off, depending on what mode the iPod is in when it is reconnected.

iPod Error Messages

If you see an error message on the screen, see page 176.

iPod® Error Messages (Models with navigation system)

If you see an error message on the screen while playing an iPod, find the solution in the chart to the right. If you cannot clear the error message, take your vehicle to your dealer.

Error Message	Solution
UNSUPPORTED	Appears when an unsupported iPod is inserted.
NO SONG	Information of music is nothing.

Playing a USB Flash Memory Device (Models with navigation system)

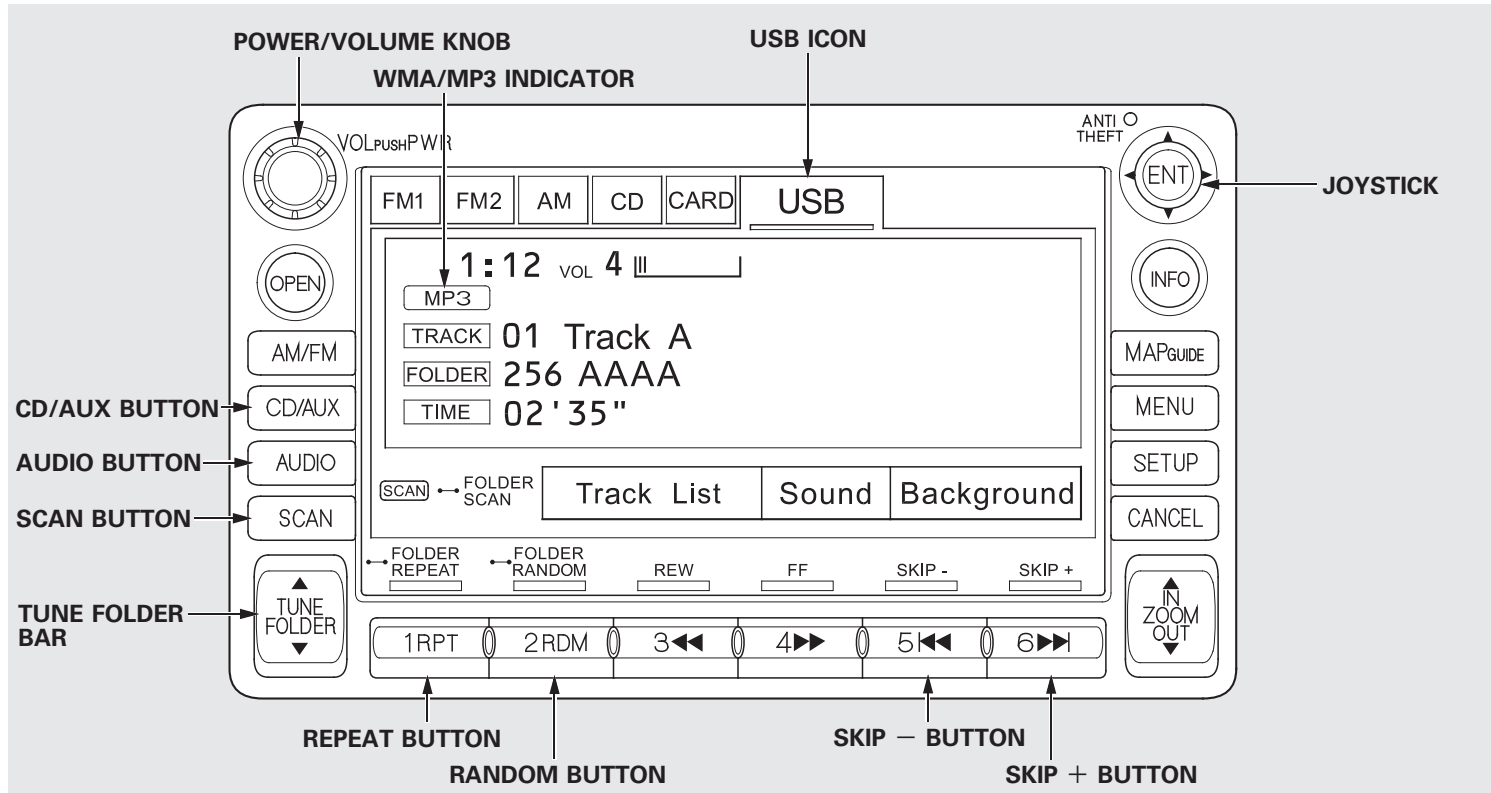

Features

CONTINUED

Playing a USB Flash Memory Device (Models with navigation system)

To Play a USB Flash Memory Device

This audio system can operate the audio files on a USB flash memory device with the same controls used for the in-dash disc player. To play a USB flash memory device, connect it to the USB adapter cable in the upper glove box, then press the CD/AUX button. The ignition switch must be in the ACCESSORY (I) or ON (II) position.

The audio system reads and plays the audio files on the USB flash memory device in MP3, WMA or AAC* formats. Depending on the format, the display shows MP3, WMA or AAC when a USB flash memory device is playing. The USB flash memory device limit is up to 700 folders or up to 65535 files.

*: Only AAC format files recorded with iTunes are playable on this audio unit.

The recommended USB flash memory devices are 256 Mbyte or higher, and formatted with the FAT file system. Some digital audio players may be compatible as well.

Some USB flash memory device (such as devices with security lockout features, etc.) will not work in this audio unit.

NOTE:

- Do not use a device such as a card reader or hard drive as the device or your files may be damaged.
- Do not connect your USB flash memory device using a HUB.
- Do not use an extension cable to the USB adapter cable equipped with your vehicle.
- Do not keep the USB flash memory device in the vehicle. Direct sunlight and high heat will damage it.

- We recommend backing up your data before playing a USB flash memory device.
- Depending on the type and number of files, it may take some time before they begin to play.
- Depending on the software the files were made with, it may not be possible to play some files, or display some text data.

Voice Control System

You can select the AUX mode by using the navigation system voice control buttons, but cannot operate the play mode functions.

The specifications for compatible MP3 files are:

- Sampling frequency:
32/44.1/48 kHz (MPEG1)
16/22.05/24 kHz (MPEG2)

Playing a USB Flash Memory Device (Models with navigation system)

- Bit rate:
32/40/48/56/64/80/96/112/128/
160/192/224/256/320/VBR kbps
(MPEG1)
8/16/24/32/40/48/56/64/80/96/
112/128/144/160/VBR kbps
(MPEG2)
- Supported standards:
MPEG1 Audio Layer3
MPEG2 Audio LSF Layer3

- Partition:
Top partition only
- Maximum layers: 8

The specifications for compatible WMA files are:

- Sampling frequency:
32/44.1/48 kHz
- Bit rate:
48 – 320/VBR kbps (Max 384)
- Supported standards:
WMA version 7/8/9

- Partition:
Top partition only
- Maximum layers: 8

The specifications for compatible AAC files are:

- Sampling frequency:
8/11.025/12/16/22.05/24/32/
44.1/48 kHz
- Bit rate:
8 – 320 kbps
- Supported standards:
MPEG4/AAC LC
MPEG2/AAC LC

- Partition:
Top partition only
- Maximum layers: 8

Even if recorded in MP3, WMA or AAC format, a file with unsupported version cannot be played. If the system finds it, the audio unit displays UNSUPPORTED, and then skips to the next file.

In WMA or AAC format, DRM (digital rights management) files cannot be played. If the system finds a DRM file, the audio unit displays UNPLAYABLE FILE, and then skips to the next file.

Connecting a USB Flash Memory Device

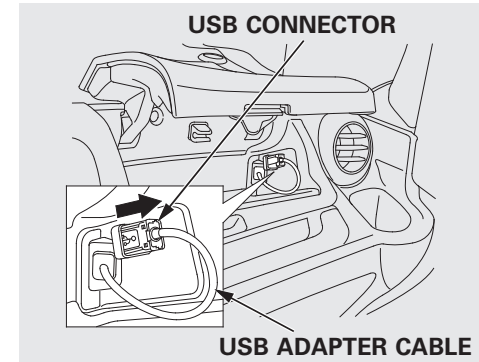

1. Open the upper glove box, and pull out the USB adapter cable.

CONTINUED

Playing a USB Flash Memory Device (Models with navigation system)

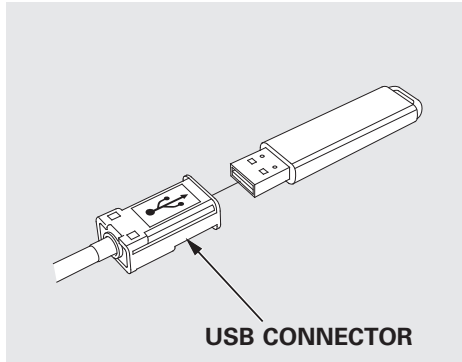

2. Connect the USB flash memory device to the USB connector correctly and securely.

When the USB flash memory device is connected and the USB mode is selected on the audio system, the WMA or MP3 indicator is shown on the navigation screen. It also shows the folder and file numbers, and the elapsed time on the screen.

To Change or Select Files

Use the SKIP button while a USB flash memory device is playing to select passages and change files.

SKIP – Each time you press the SKIP + button (Preset 6), the system skips forward to the beginning of the next file. Press the SKIP – button (Preset 5), to skip backward to the beginning of the current file. Press it again to skip to the beginning of the previous file.

FOLDER SELECTION – To select a different folder, press either side of the TUNE FOLDER bar. Press the ▲ side to skip to the next folder, and press the ▼ side to skip to the beginning of the previous folder.

Using a Track List

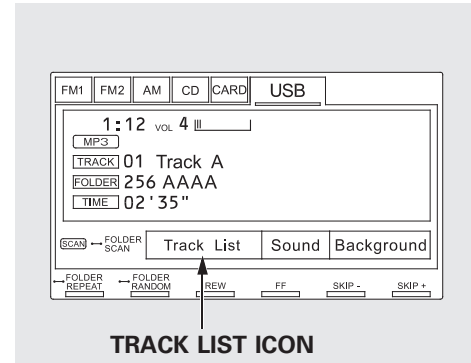

You can also select a file directly from a track list on the audio display. Press the AUDIO button to show the audio display, then touch the Track List icon. The track list menu appears on the display.

Playing a USB Flash Memory Device (Models with navigation system)

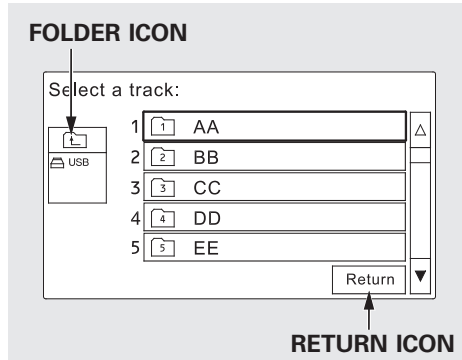

To scroll through the display, touch the ▲ or ▼ icon on the side of the screen. To go back to the previous display, touch the Return icon.

To play a file, touch its icon on the screen. The current folder is highlighted in blue.

To Select Repeat, Random or Scan Mode:

You can select any type of repeat, random and scan modes by using the RPT button or RDM button, or SCAN button.

TRACK REPEAT – This feature continuously plays a file. To activate the track repeat feature, press the RPT button (Preset 1). You will see “TRACK REPEAT” in the display. To turn it off, press the RPT button (Preset 1).

FOLDER REPEAT – This feature replays all the files in the selected folder in the order they are stored. To activate the folder repeat feature, press and hold the RPT button (Preset 1). You will see “FOLDER REPEAT” in the display. To turn it off, press and hold the RPT button (Preset 1).

TRACK RANDOM – This feature plays all the files in random order. To activate the track random feature, press the RDM button (Preset 2). You will see “TRACK RANDOM” in the display. To turn it off, press the RDM button (Preset 2).

FOLDER RANDOM – This feature plays the files in the selected folder in random order. To activate the folder random feature, press and hold the RDM button (Preset 2). You will see “FOLDER RANDOM” in the display. To turn it off, press and hold the RDM button (Preset 2).

TRACK SCAN – This feature samples all files in the selected folder in the order they are stored. To activate the scan feature, press the SCAN button. You will see “TRACK SCAN” in the display. You will also see the file number blinking. You will get a 10 second sampling of each file in the folder. Press the SCAN button to get out of the scan mode. The system plays the last file sampled.

CONTINUED

Playing a USB Flash Memory Device (Models with navigation system)

FOLDER SCAN – This feature samples the first file in each folder in the order they are stored. To activate the folder scan feature, press and hold the SCAN button. You will see “FOLDER SCAN” in the display. You will also see the folder number blinking. You will get a 10 second sampling of each first file in the folder(s). Press the SCAN button to get out of the scan mode. The system plays the last file sampled.

To Stop Playing a USB Flash Memory Device

To play the radio when a USB flash memory device is playing, press the FM/AM button or touch the FM1, FM2, or AM icon. If a disc is in the audio unit, press the CD/AUX button or touch the CD icon to play the disc. If a PC card is in the audio unit, press the CD/AUX button or touch the CARD icon to play a PC card.

Press the CD/AUX button again or touch the AUX icon to switch back to the USB flash memory device.

Disconnecting a USB Flash Memory Device

You can disconnect the USB flash memory device in any time even if the USB mode is selected on the audio system. Always follow the USB flash memory device's instructions when you remove it.

When you disconnect the USB flash memory device while it is playing, the navigation screen shows “NO DATA.”

If you reconnect the same USB flash memory device, the system will begin playing where it left off.

USB Flash Memory Device Error Messages

If you see an error message on the screen, see page 183.

USB Flash Memory Device Error Messages (Models with navigation system)

If you see an error message on the screen while playing a USB flash memory device, find the solution in the chart to the right. If you cannot clear the error message, take your vehicle to your dealer.

Error Message	Solution
UNPLAYABLE FILE	The system cannot read the file(s). Check the files in the USB flash memory device. There is a possibility that the files have been damaged.
UNSUPPORTED	Appears when the unsupported USB flash memory device is inserted.
NO SONG	Information of music is nothing.

FM/AM Radio Reception

Radio Frequencies

The radio can receive the complete AM and FM bands.

Those bands cover these frequencies:

AM band: 530 to 1,710 kHz

FM band: 87.7 to 107.9 MHz

Radio stations on the AM band are assigned frequencies at least 10 kHz apart (530, 540, 550). Stations on the FM band are assigned frequencies at least 0.2 MHz apart (87.9, 88.1, 88.3).

Stations must use these exact frequencies. It is fairly common for stations to round-off the frequency in their advertising, so your radio could display a frequency of 100.9 even though the announcer may identify the station as "FM101."

Radio Reception

How well the radio receives stations is dependent on many factors, such as the distance from the station's transmitter, nearby large objects, and atmospheric conditions.

A radio station's signal gets weaker as you get farther away from its transmitter. If you are listening to an AM station, you will notice the sound volume becoming weaker, and the station drifting in and out. If you are listening to an FM station, you will see the stereo indicator flickering off and on as the signal weakens. Eventually, the stereo indicator will go off and the sound will fade completely as you get out of range of the station's signal.

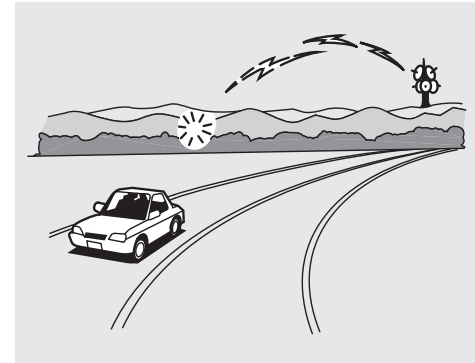

Driving very near the transmitter of a station that is broadcasting on a frequency close to the frequency of the station you are listening to can also affect your radio's reception. You may temporarily hear both stations, or hear only the station you are close to.

FM/AM Radio Reception

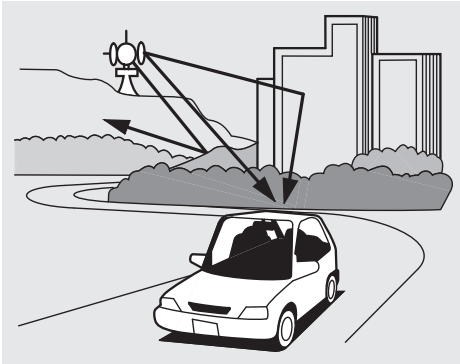

Radio signals, especially on the FM band, are deflected by large objects such as buildings and hills. Your radio then receives both the direct signal from the station's transmitter, and the deflected signal. This causes the sound to distort or flutter. This is a main cause of poor radio reception in city driving.



Radio reception can be affected by atmospheric conditions such as thunderstorms, high humidity, and even sunspots. You may be able to receive a distant radio station one day and not receive it the next day because of a change in conditions.

Electrical interference from passing vehicles and stationary sources can cause temporary reception problems.

*As required by the FCC:
Changes or modifications not expressly
approved by the party responsible for
compliance could void the user's
authority to operate the equipment.*

Protecting Your Discs

General Information

- When using CD-R or CD-RW discs, use only high quality discs labeled for audio use.
- When recording a CD-R or CD-RW, the recording must be closed for it to be used by the system.
- Play only standard round discs. Odd-shaped discs may jam in the drive or cause other problems.
- Handle your discs properly to prevent damage and skipping.

NOTICE

Do not use discs with adhesive labels. The label can curl up and cause the disc to jam in the unit.

Protecting Discs

When a disc is not being played, store it in its case to protect it from dust and other contamination. To prevent warpage, keep discs out of direct sunlight and extreme heat.

To clean a disc, use a clean soft cloth. Wipe across the disc from the center to the outside edge.

A new disc may be rough on the inner and outer edges. The small plastic pieces causing this roughness can flake off and fall on the recording surface of the disc, causing skipping or other problems. Remove these pieces by rubbing the inner and outer edges with the side of a pencil or pen.

Never try to insert foreign objects in the disc player.

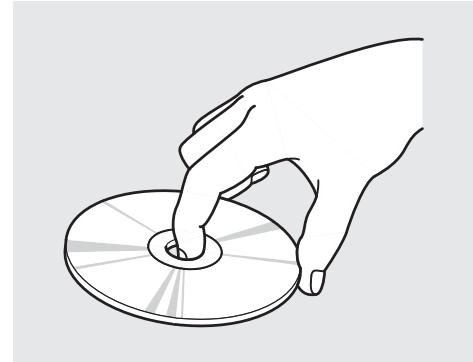

Handle a disc by its edges; never touch either surface. Do not place stabilizer rings or labels on the disc. These, along with contamination from finger prints, liquids, and felt-tip pens, can cause the disc to not play properly, or possibly jam in the drive.

Protecting Your Discs

Additional Information of Recommended Discs

The in-dash disc player has a sophisticated and delicate mechanism. If you insert a damaged disc as indicated in this section, it may become stuck inside and damage the audio unit.

Examples of these discs are shown to the right:

1. Bubbled, wrinkled, labelled, and excessively thick discs

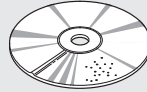

**Bubbled/
Wrinkled**

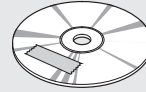

**With Label/
Sticker**



**Using Printer
Label Kit**

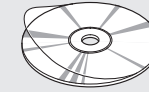

Sealed

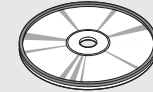

**With Plastic
Ring**

2. Damaged discs

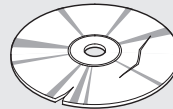

**Chipped/
Cracked**

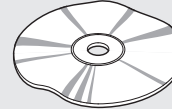

Warped

3. Poor quality discs

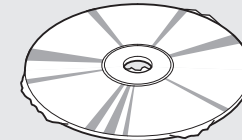

Burrs

CONTINUED

Protecting Your Discs

4. Small, irregular shaped discs

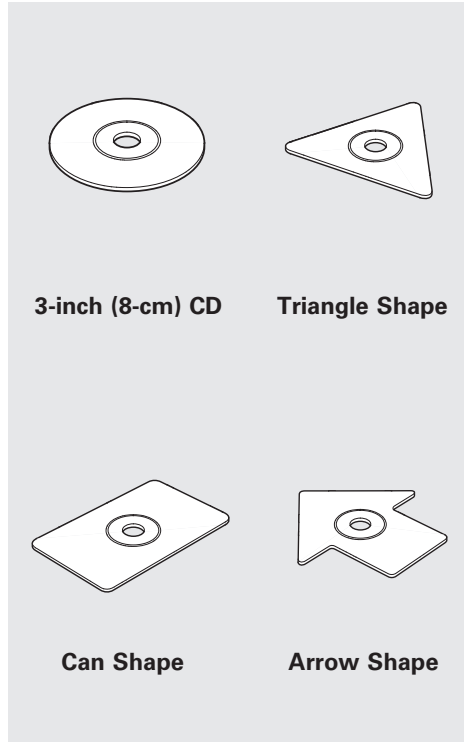

5. Discs with scratches, dirty discs

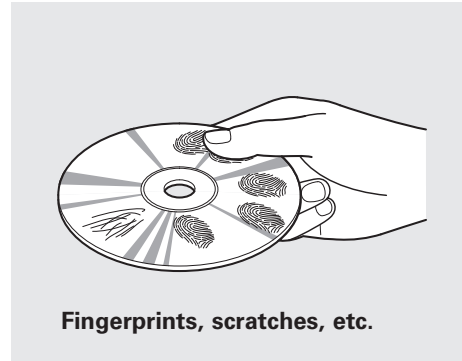

- CD-R or CD-RW may not play due to the recording conditions.
- Scratches and fingerprints on the discs may cause the sound to skip.

- Recommended discs are printed with the following logo.



- Audio unit may not play the following formats.



Remote Audio Controls

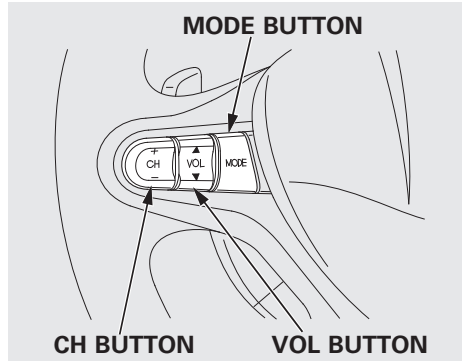

On vehicles with navigation system
Three controls for the audio system are mounted in the steering wheel hub. These let you control basic functions without removing your hand from the wheel.

The VOL button adjusts the volume up (▲) or down (▼). Press the top or bottom of the button and hold it until the desired volume is reached, then release it.

The MODE button changes the mode. Pressing the button repeatedly selects FM1, FM2, AM, disc or a PC card (if a disc or a PC card is loaded), or an audio unit connected to the auxiliary input jack or the USB adapter cable.

If you are listening to the radio, use the CH button to change stations. Each time you press the top (+) of the button, the system goes to the next preset station on the band you are listening to. Press the bottom (-) to go back to the previous station. If you press and hold the CH button (+) or (-), the system goes into the seek mode. It finds a station with a strong signal.

If you are playing a disc, iPod or USB flash memory device, the system skips to the beginning of the next track (file in MP3, WMA or AAC format) each time you press the top (+) of the CH button. Press the bottom (-) to return to the beginning of the current track/file. Press it twice to return to the previous track/file.

You will see the track/file number and the elapsed time. If the disc has text data or is compressed in MP3 or WMA, you can also see any other information (track title, file name, folder name, etc.).

CONTINUED

Remote Audio Controls, Auxiliary Input Jack

In MP3 or WMA mode, you can use the skip function to select folders. Press and hold the top (+) of the CH button until you hear a beep, to skip forward to the first file of the next folder. Press the bottom (-) to skip backward to the previous folder.

If you are playing a PC card, press the top (+) of the CH button to advance to the next file. Press the bottom (-) to go back to the previous file.

Auxiliary Input Jack

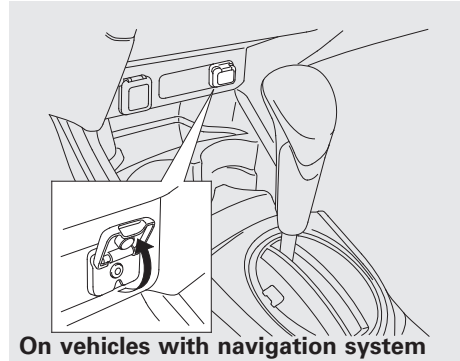

Your vehicle has the auxiliary input jack on the front panel. The system will accept auxiliary input from standard audio accessories.

When a compatible audio unit is connected to the jack, press the CD/AUX (On vehicles with navigation system) or AUX (On vehicles without navigation system) button to select it.

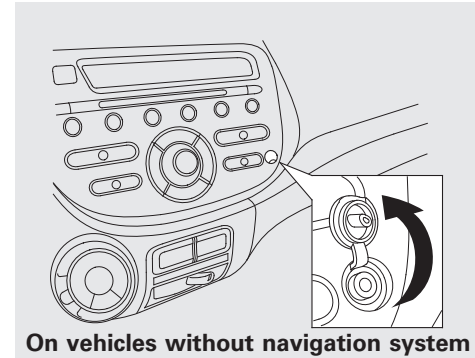

Your vehicle's audio system will disable itself if it is disconnected from electrical power for any reason. To make it work again, you must enter a specific digit code using the preset buttons. Because there are hundreds of number combinations possible from specific digits, making the system work without knowing the exact code is nearly impossible.

You should have received a card that lists your audio system's code and serial numbers. It is best to store this card in a safe place at home. In addition, you should write the audio system's serial number in this owner's manual.

If you lose the card, you must obtain the code number from a dealer. To do this, you will need the system's serial number.

If your vehicle's battery is disconnected or goes dead, or the radio fuse is removed, the audio system will disable itself. If this happens, you will see "ENTER CODE" in the frequency display the next time you turn on the system. Use the preset buttons to enter the code. On vehicles with navigation system, touch the Done icon to set the code. The code is on the radio code card included in your owner's manual kit. When it is entered correctly, the radio will start playing.

If you make a mistake entering the code, do not start over; complete the sequence, then enter the correct code. You have 10 tries to enter the correct code. If you are unsuccessful in 10 attempts, you must then leave the system on for 1 hour before trying again.

Setting the Clock

On vehicles without navigation system

Press and hold the FM/AM (CLOCK) button until the displayed time begins to blink, then release the button. Change the hours by pressing the 1 (H) button until the numbers advance to the desired time. Change the minutes by pressing the 2 (M) button until the numbers advance to the desired time.

Press the FM/AM (CLOCK) button again to enter the set time.

You can quickly set the time to the nearest hour. If the displayed time is before the half hour, press the FM/AM (CLOCK) button until you hear a beep, then press the 3 (R) button to set the clock back to the previous hour. If the displayed time is after the half hour, the clock sets forward to the beginning of the next hour.

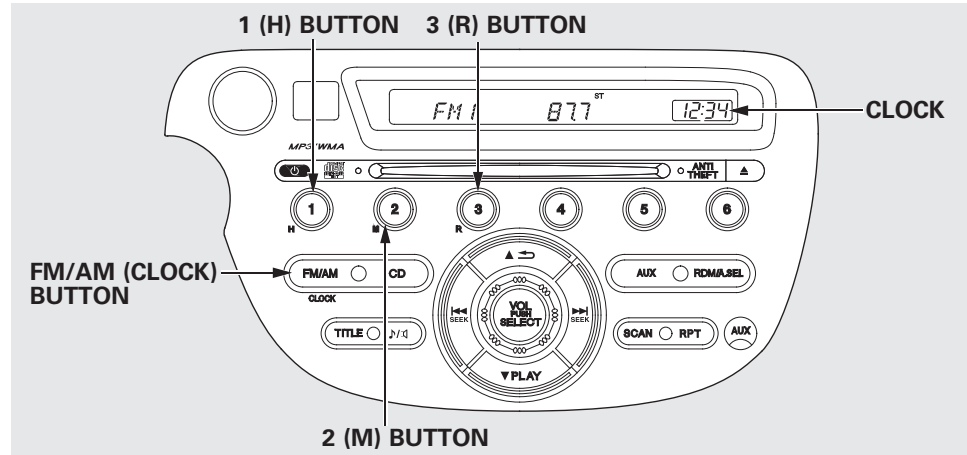

For example:
1:06 will reset to 1:00
1:53 will reset to 2:00

On vehicles with navigation system

The navigation system receives signals from the global positioning system (GPS), and the displayed time is updated automatically by the GPS. Refer to the navigation system manual for how to adjust the time.

On Sport model

The security system helps to protect your vehicle and valuables from theft. The horn sounds and a combination of headlights, parking/side marker lights and taillights flashes if someone attempts to break into your vehicle or remove the audio unit. This alarm continues for 2 minutes, then the system resets. To reset an activated system before the 2 minutes have elapsed, unlock the driver's door with the key or the remote transmitter.

The security system automatically sets 15 seconds after you lock the doors, hood, and the tailgate. For the system to activate, you must lock the doors and the tailgate from the outside with the key, driver's lock tab, door lock master switch, or remote transmitter. The security system indicator on the instrument panel starts blinking immediately to show you the system is setting itself.

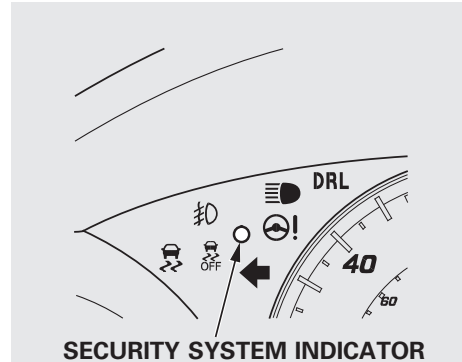

Once the security system is set, opening any door, the tailgate, or the hood without using the key or the remote transmitter, will cause the alarm to activate. It also activates if the audio unit is removed from the dashboard or the wiring is cut.

The alarm will also activate if a passenger inside the locked vehicle turns the ignition switch on.

The security system will not set if the hood, tailgate, or any door is not fully closed. If the system will not set, check the door and tailgate open indicator on the instrument panel (see page 62) to see if the doors and tailgate are fully closed. Since it is not part of the monitor display, manually check the hood.

NOTE: To see if the system is set after you exit the vehicle, press the LOCK button on the remote transmitter within 5 seconds. If the system is set, the horn will beep once.

Do not attempt to alter this system or add other devices to it.

Cruise Control

On Sport model and Canadian LX model Cruise control allows you to maintain a set speed above 25 mph (40 km/h) without keeping your foot on the accelerator pedal. It should be used for cruising on straight, open highways. It is not recommended for city driving, winding roads, slippery roads, heavy rain, or bad weather.

⚠ WARNING

Improper use of the cruise control can lead to a crash.

Use the cruise control only when traveling on open highways in good weather.

Using the Cruise Control

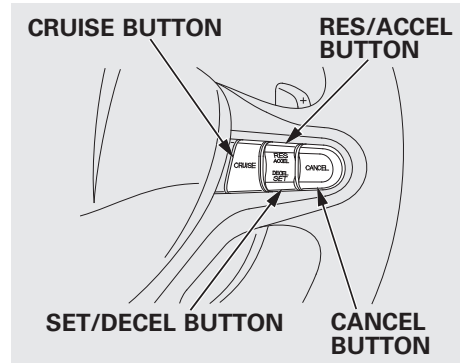

1. Press the CRUISE button on the steering wheel. The CRUISE MAIN indicator on the instrument panel comes on.

NOTE: The main switch can be left on, even when the system is not in use.

2. Accelerate to the desired cruising speed above 25 mph (40 km/h).

3. Press the SET/DECEL button on the steering wheel. The CRUISE CONTROL indicator on the instrument panel comes on to show the system is now activated.

Cruise control may not hold the set speed when you are going up and down hills. If your speed increases going down a hill, use the brakes to slow down. This will cancel cruise control. To resume the set speed, press the RES/ACCEL button. The indicator on the instrument panel will come back on.

When climbing a steep hill, the automatic transmission may downshift to hold the set speed.

Changing the Set Speed

You can increase the set cruising speed in any of these ways:

- Press and hold the RES/ACCEL button. When you reach the desired cruising speed, release the button.
- To increase your speed in very small amounts, tap the RES/ACCEL button. Each time you do this, the vehicle will speed up about 1 mph (1.6 km/h).
- Push on the accelerator pedal. Accelerate to the desired cruising speed, then press the SET/DECEL button.

You can decrease the set cruising speed in any of these ways:

- Press and hold the SET/DECEL button. Release the button when you reach the desired speed.
- To slow down in very small amounts, tap the SET/DECEL button. Each time you do this, your vehicle will slow down about 1 mph (1.6 km/h).
- Tap the brake or clutch pedal lightly with your foot. The CRUISE CONTROL indicator on the instrument panel goes out. When the vehicle slows to the desired speed, press the SET/DECEL button.

Even with the cruise control turned on, you can still use the accelerator pedal to speed up for passing. After completing the pass, take your foot off the accelerator pedal. The vehicle will return to the set cruising speed.

Resting your foot on the brake or clutch pedal causes the cruise control to cancel.

CONTINUED

Cruise Control

Canceling Cruise Control

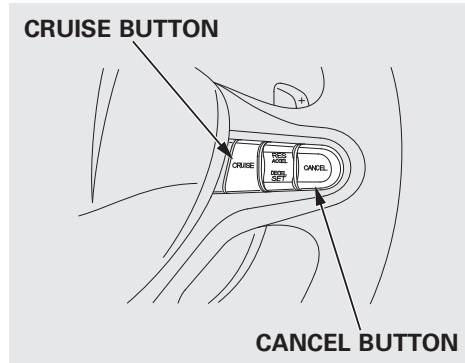

You can cancel cruise control in any of these ways:

- Tap the brake or clutch pedal.
- Press the CANCEL button on the steering wheel.
- Press the CRUISE button on the steering wheel.

Tapping either of the paddle shifters shifts the gear up or down, but does not cancel the cruise control. For more information on driving with paddle shifters, see page 224.

Resuming the Set Speed

When you push the CANCEL button, or tap the brake or clutch pedal, the system will remember the previously set cruising speed. To return to that speed, accelerate to above 25 mph (40 km/h), and then press the RES/ACCEL button. The CRUISE CONTROL indicator comes on. The vehicle will accelerate to the same cruising speed as before.

Pressing the CRUISE button turns the system off and erases the previous cruising speed.

Before you begin driving your vehicle, you should know what gasoline to use and how to check the levels of important fluids. You also need to know how to properly store luggage or packages. The information in this section will help you. If you plan to add any accessories to your vehicle, please read the information in this section first.

Break-in Period	198
Fuel Recommendation	198
Service Station Procedures	199
Refueling.....	199
Opening and Closing the Hood	200
Oil Check.....	201
Engine Coolant Check	202
Fuel Economy	203
Accessories and Modifications	206
Carrying Cargo	208

Break-in Period, Fuel Recommendation

Break-in Period

Help assure your vehicle's future reliability and performance by paying extra attention to how you drive during the first 600 miles (1,000 km). During this period:

- Avoid full-throttle starts and rapid acceleration.
- Avoid hard braking for the first 200 miles (300 km).
- Do not change the oil until the scheduled maintenance time.

You should also follow these recommendations with an overhauled or exchanged engine, or when the brakes are replaced.

Fuel Recommendation

Your vehicle is designed to operate on unleaded gasoline with a pump octane number of 87 or higher. Use of a lower octane gasoline can cause a persistent, heavy metallic rapping noise that can lead to engine damage.

We recommend using quality gasolines containing detergent additives that help prevent fuel system and engine deposits.

In addition, in order to maintain good performance, fuel economy, and emissions control, we strongly recommend, in areas where it is available, the use of gasoline that does NOT contain manganese-based fuel additives such as MMT.

Use of gasoline with these additives may adversely affect performance, and cause the malfunction indicator lamp on your instrument panel to come on. If this happens, contact your authorized dealer for service.

Some gasoline today is blended with oxygenates such as ethanol or MTBE. Your vehicle is designed to operate on oxygenated gasoline containing up to 10% ethanol by volume and up to 15% MTBE by volume. Do not use gasoline containing methanol.

If you notice any undesirable operating symptoms, try another service station or switch to another brand of gasoline.

For further important fuel-related information for your vehicle, or information on gasoline that does not contain MMT, visit Owner Link at owners.honda.com. In Canada, visit www.honda.ca for additoin information on gasoine.

Refueling

1. Park with the driver's side closest to the service station pump.

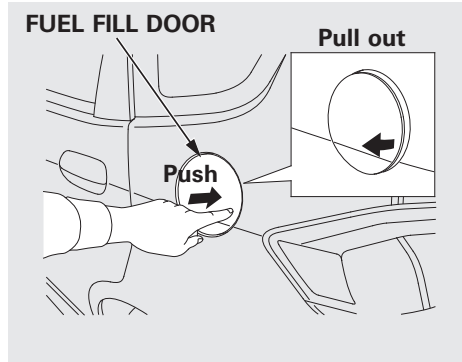

2. Outside of the vehicle, push on the right side edge of the fuel fill door in the middle. The fuel fill door will pop up slightly. Pull it outward to open it.

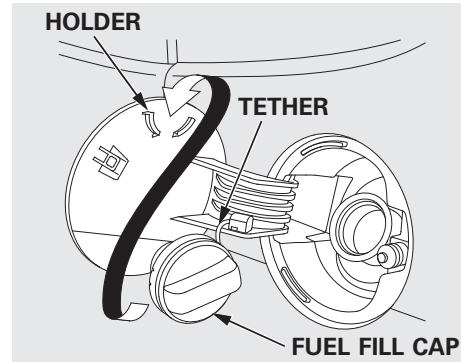

3. Remove the fuel fill cap slowly. You may hear a hissing sound as pressure inside the tank escapes. Place the fuel fill cap in the holder on the fuel fill door. To prevent the fuel fill cap from becoming lost, it is attached to the fuel filler with a tether.

4. Stop filling the tank after the fuel nozzle automatically clicks off. Do not try to "top off" the tank. Leave some room for the fuel to expand with temperature changes.

If the fuel nozzle keeps clicking off even though the tank is not full, there may be a problem with your vehicle's fuel vapor recovery system. The system helps keep fuel vapor from going into the atmosphere. Try filling at another pump. If this does not fix the problem, consult your dealer.

CONTINUED

Service Station Procedures

⚠ WARNING

Gasoline is highly flammable and explosive. You can be burned or seriously injured when handling fuel.

- Stop the engine, and keep heat, sparks, and flame away.
- Handle fuel only outdoors.
- Wipe up spills immediately.

5. Screw the fuel fill cap back on until it clicks at least once. If you do not properly tighten the cap, the malfunction indicator lamp may come on (see page 304). You will also see a “CHECK FUEL CAP” message on the information display.
6. Push the fuel fill door closed until it latches.

Opening and Closing the Hood

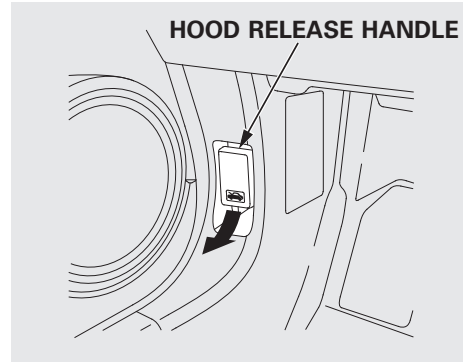

1. Park the vehicle, and set the parking brake. Pull the hood release handle under the lower left corner of the dashboard. The hood will pop up slightly.

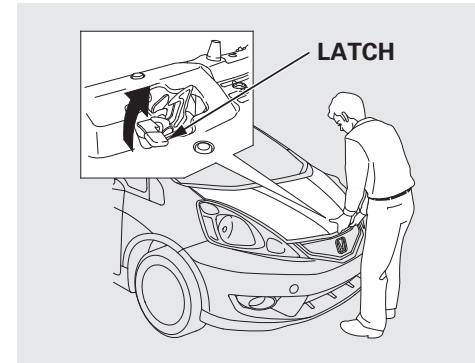

2. Put your fingers under the front edge of the hood near the center. Slide your hand to the left until you feel the hood latch handle. Push this handle up to release it. Lift up the hood.

If the hood latch handle moves stiffly, or if you can open the hood without lifting the handle, the mechanism should be cleaned and lubricated.

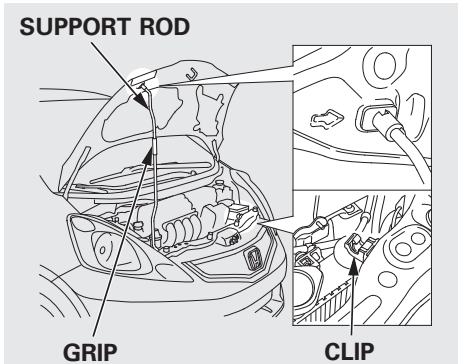

3. Holding the grip, pull the support rod out of its clip. Insert the end into the designated hole in the hood.

To close the hood, lift it up slightly to remove the support rod from the hole. Put the support rod back into its holding clip. Lower the hood to about a foot (30 cm) above the fender, then let it drop. Make sure it is securely latched.

Oil Check

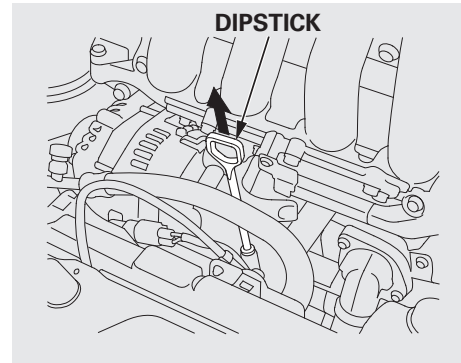

Wait a few minutes after turning the engine off before you check the oil.

1. Remove the dipstick (orange loop).
2. Wipe off the dipstick with a clean cloth or paper towel.
3. Insert the dipstick all the way back into its hole.

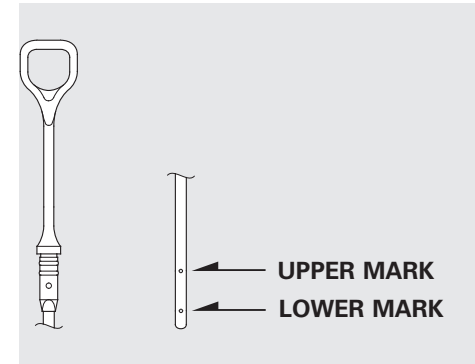

4. Remove the dipstick again, and check the level. It should be between the upper and lower marks.

If it is near or below the lower mark, see **Adding Engine Oil** on page 253.

Service Station Procedures

Engine Coolant Check

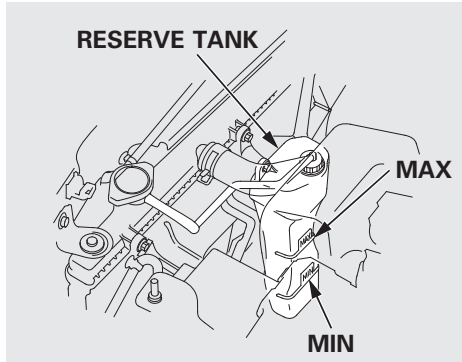

Look at the coolant level in the radiator reserve tank. Make sure it is between the MAX and MIN lines. If it is below the MIN line, see **Adding Engine Coolant** on page 256 for information on adding the proper coolant.

Refer to **Owner's Maintenance Checks** on page 250 for information about checking other items on your vehicle.

Actual Mileage and EPA Fuel Economy Estimates Comparison. Fuel economy is not a fixed number. It varies based on driving conditions, driving habits and vehicle condition. Therefore, it is not possible for one set of estimates to predict fuel economy precisely for all drivers in all environments.

The EPA fuel economy estimates shown in the example to the right are a useful tool for comparison when buying a vehicle. EPA estimates include:

City MPG – Represents urban driving in a vehicle in light traffic. A range of miles per gallon achieved is also provided.

Highway MPG – Represents a mixture of rural and interstate driving, in a warmed-up vehicle, typical of longer trips in free-flowing traffic. A range of miles per gallon achieved is also provided.

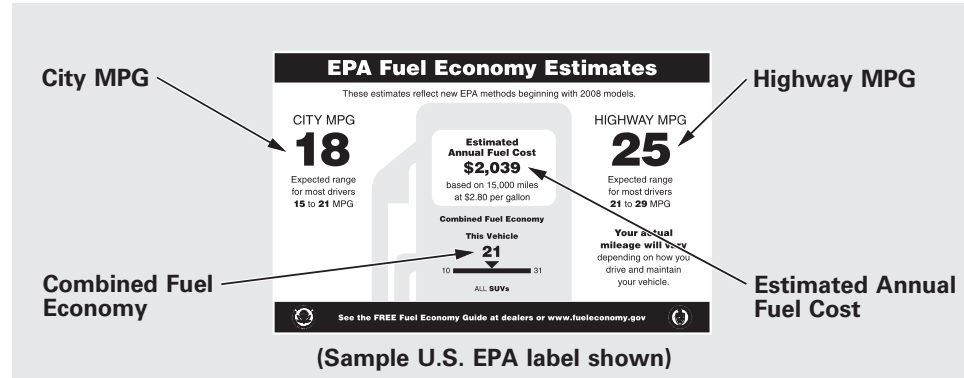

Combined Fuel Economy – Represents a combination of city and highway driving. The scale represents the range of combined fuel economy for other vehicles in the class.

Estimated Annual Fuel Cost – Provides an estimated annual fuel cost, based on 15,000 miles (20,000 km) per year multiplied by the cost per gallon (based on EPA fuel cost data) divided by the combined fuel economy.

For more information on fuel economy ratings and factors that affect fuel economy, visit www.fueleconomy.gov (Canada: Visit www.vehicles.gc.ca)

CONTINUED

Fuel Economy

Fuel Economy Factors

The following factors can lower your vehicle's fuel economy:

- Aggressive driving (hard acceleration and braking)
- Excessive idling, accelerating and braking in stop-and-go traffic
- Cold engine operation (engines are more efficient when warmed up)
- Driving with a heavy load or the air conditioner running
- Improperly inflated tires

Improving Fuel Economy

Vehicle Maintenance

A properly maintained vehicle maximizes fuel economy. Poor maintenance can significantly reduce fuel economy. Always maintain your vehicle according to the maintenance messages displayed on the information display (see **Owner's Maintenance Checks** on page 250). For example:

- **Use the recommended viscosity motor oil, displaying the API Certification Seal (see page 253).**
- **Maintain proper tire inflation** – An under-inflated tire increases “rolling resistance,” which reduces fuel economy.
- **Avoid carrying excess weight in your vehicle** – It puts a heavier load on the engine, increasing fuel consumption.

- **Keep your vehicle clean** – In particular, a build-up of snow or mud on your vehicle's underside adds weight and rolling resistance. Frequent cleaning helps your fuel economy.

Drive Efficiently

- **Drive moderately** – Rapid acceleration, abrupt cornering, and hard braking increase fuel consumption.
- **Observe the speed limit** – Aerodynamic drag has a big effect on fuel mileage at speeds above 45 mph (75 km/h). Reduce your speed and you reduce the drag. Trailers, car top carriers, roof racks and bike racks are also big contributors to increased drag.
- **Always drive in the highest gear possible** – If your vehicle has a manual transmission, you can boost your fuel economy by up shifting as early as possible.

- **Avoid excessive idling** – Idling results in 0 miles per gallon.
- **Minimize the use of the air conditioning system** – The A/C puts an extra load on the engine which makes it use more fuel. Use the fresh-air ventilation when possible.
- **Plan and combine trips** – Combine several short trips into one. A warmed-up engine is more fuel efficient than a cold one.

Calculating Fuel Economy

Measuring Techniques

Direct calculation is the recommended source of information about your actual fuel economy. Using frequency of fill-ups or taking fuel gauge readings are NOT accurate measures of fuel economy. Fuel economy may improve over the first several thousand miles.

Checking Your Fuel Economy

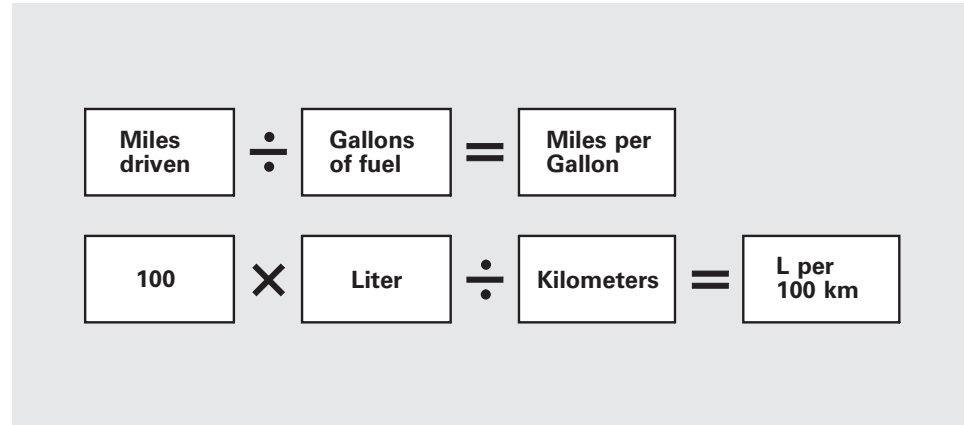

- 1) Fill the fuel tank until the nozzle automatically clicks off.
- 2) Reset trip counter to zero.
- 3) Record the total gallons (liters) needed to refill.
- 4) Follow one of the simple calculations above.

Accessories and Modifications

Modifying your vehicle, or installing some non-Honda accessories, can make it unsafe. Before you make any modifications or add any accessories, be sure to read the following information.

Accessories

Your dealer has Honda accessories that allow you to personalize your vehicle. These accessories have been designed and approved for your vehicle, and are covered by warranty.

Although non-Honda accessories may fit on your vehicle, they may not meet factory specifications, and could adversely affect your vehicle's handling and stability.

WARNING

Improper accessories or modifications can affect your vehicle's handling, stability, and performance, and cause a crash in which you can be hurt or killed.

Follow all instructions in this owner's manual regarding accessories and modifications.

When properly installed, cellular phones, alarms, two-way radios, and low-powered audio systems should not interfere with your vehicle's computer controlled systems, such as your airbags, anti-lock brakes, and tire pressure monitoring system (if equipped).

Before installing any accessory:

- Make sure the accessory does not obscure any lights, or interfere with proper vehicle operation or performance.
- Be sure electronic accessories do not overload electrical circuits (see page 307) or interfere with proper operation of your vehicle.
- Before installing any electronic accessory, have the installer contact your dealer for assistance. If possible, have your dealer inspect the final installation.
- Do not install accessories on the side pillars or across the rear windows. Accessories installed in these areas may interfere with proper operation of the side curtain airbags.

Modifying Your Vehicle

Removing parts from your vehicle, or replacing components with non-Honda components could seriously affect your vehicle's handling, stability, and reliability.

Here are some examples:

- Lowering your vehicle with a non-Honda suspension kit that significantly reduces ground clearance can allow the undercarriage to hit speed bumps or other raised objects, which could cause the airbags to deploy.
- Raising your vehicle with a non-Honda suspension kit can affect the handling and stability.

- Non-Honda wheels, because they are a universal design, can cause excessive stress on suspension components and will not be compatible with the tire pressure monitoring system (TPMS)*.

*: If equipped

- Larger or smaller wheels and tires can interfere with the operation of your vehicle's anti-lock brakes and other systems.
- Modifying your steering wheel or any other part of your vehicle's safety features can make the systems ineffective.

If you plan to modify your vehicle, consult your dealer.

Carrying Cargo

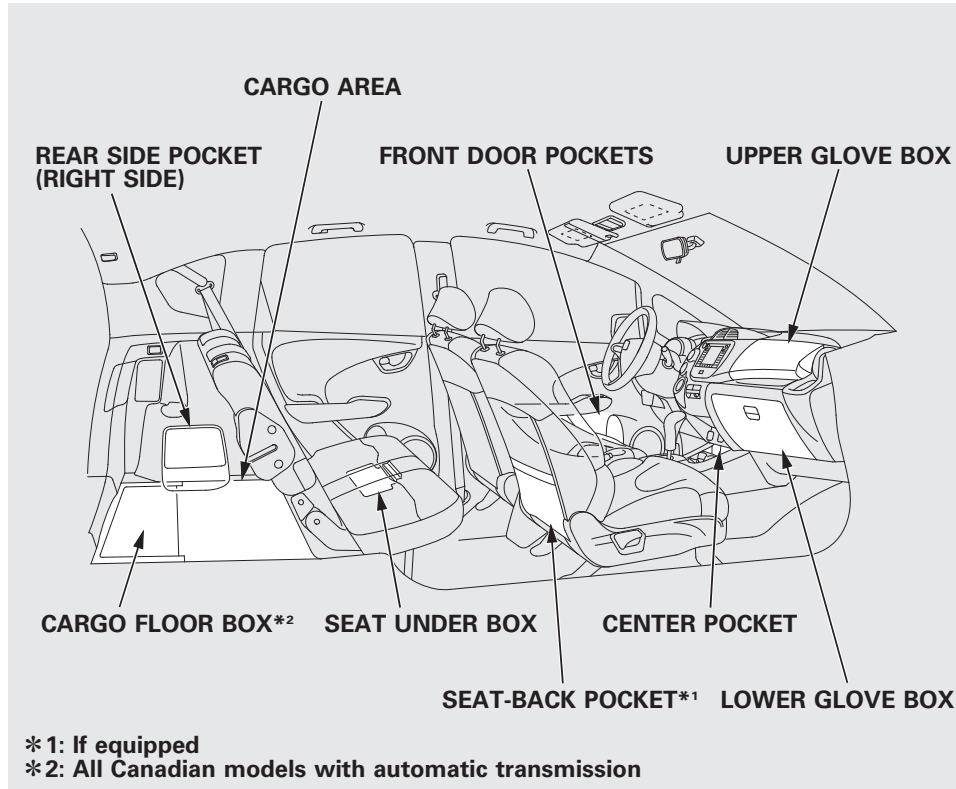

Your vehicle has several convenient storage areas:

- Upper glove box
- Lower glove box
- Front door pockets
- Seat-back pocket (if equipped)
- Center pocket
- Cargo area side pocket
- Cargo area, including the rear seats when folded up or down.
- Seat under box
- Cargo floor box (all Canadian models with automatic transmission)

However, carrying too much cargo, or improperly storing it, can affect your vehicle's handling, stability, stopping distance, tires, and make it unsafe. Before carrying any type of cargo, be sure to read the following pages.

Load Limits (Payload)

The maximum load for your vehicle is 850 lbs (385 kg).

See Tire And Loading Information label attached to the driver's doorjamb.

Label Example

TIRE AND LOADING INFORMATION			
SEATING CAPACITY		TOTAL 5	FRONT 2 REAR 3
The combined weight of occupants and cargo should never exceed 385kg or 850lbs.			
TIRE	SIZE	COLD TIRE PRESSURE	SEE OWNEW'S MANUAL FOR ADDITIONAL INFORMATION
FRONT	XXXX/XXRXX XXX	XXX KPA , XX PSI	
REAR	XXXX/XXRXX XXX	XXX KPA , XX PSI	
SPARE	XXXX/XXDXX XXX	XXX KPA , XX PSI	

This figure includes the total weight of all occupants, cargo, and accessories, and the tongue load if you are towing a trailer.

⚠ WARNING

Overloading or improper loading can affect handling and stability and cause a crash in which you can be hurt or killed.

Follow all load limits and other loading guidelines in this manual.

Steps for Determining Correct Load Limit –

1. Locate the statement “The combined weight of occupants and cargo should never exceed XXX kg or XXX lbs.” on your vehicle's placard.
2. Determine the combined weight of the driver and passengers that will be riding in your vehicle.
3. Subtract the combined weight of the driver and passengers from XXX kg or XXX lbs.



CONTINUED

Carrying Cargo

4. The resulting figure equals the available amount of cargo and luggage load capacity. For example, if the “XXX” amount equals 1,400 lbs. and there will be five 150 lb. passengers in your vehicle, the amount of available cargo and luggage load capacity is 650 lbs.
 $(1,400 - 750 (5 \times 150) = 650$ lbs.)

5. Determine the combined weight of luggage and cargo being loaded on the vehicle. That weight may not safely exceed the available cargo and luggage load capacity calculated in Step 4.

6. If your vehicle will be towing a trailer, load from your trailer will be transferred to your vehicle. Consult this manual to determine how this reduces the available cargo and luggage load capacity of your vehicle.

Example 1	 <p>Max Load (850 lbs) Passenger Weight $(150 \text{ lbs} \times 2 = 300 \text{ lbs})$ Cargo Weight (550 lbs)</p>
Example 2	 <p>Max Load (850 lbs) Passenger Weight $(150 \text{ lbs} \times 4 = 600 \text{ lbs})$ Cargo Weight (250 lbs)</p>
Example 3	 <p>Max Load (850 lbs) Passenger Weight $(150 \text{ lbs} \times 5 = 750 \text{ lbs})$ Cargo Weight (100 lbs)</p>

In addition, the total weight of the vehicle, all occupants, accessories, cargo, and trailer tongue load must not exceed the Gross Vehicle Weight Rating (GVWR) or the Gross Axle Weight Rating (GAWR). Both are on a label on the driver's doorjamb.

Carrying Cargo in the Passenger Compartment

- Store or secure all items that could be thrown around and hurt someone during a crash.
- Be sure items placed on the floor behind the front seats cannot roll under the seats and interfere with the driver's ability to operate the pedals, the proper operation of the seats, or proper operation of the sensors under the seats.
- Keep the upper and lower glove boxes closed while driving. If it is open, a passenger could injure their knees during a crash or sudden stop.

- If you fold the rear seats up or down, tie down items that could be thrown about the vehicle during a crash or sudden stop. Also, keep all cargo below the bottom of the windows. If it is higher, it could interfere with the proper operation of the side curtain airbags.

Carrying Cargo in the Cargo Area

- Distribute cargo evenly on the floor of the cargo area, placing the heaviest items on the bottom and as far forward as possible. Tie down items that could be thrown about the vehicle during a crash or sudden stop.
- Do not stack items higher than the back of the rear seats. They can block your view and be thrown around the vehicle during a crash.
- If you carry large items that prevent you from closing the tailgate, exhaust gas can enter the passenger area. To avoid the possibility of **carbon monoxide poisoning**, follow the instructions on page 53.

CONTINUED

Carrying Cargo

Cargo Hooks

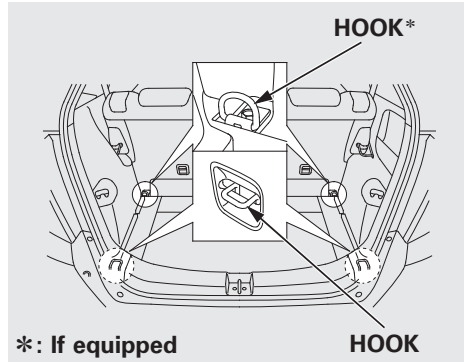

The two or four hooks on the floor can be used to install a net for securing items.

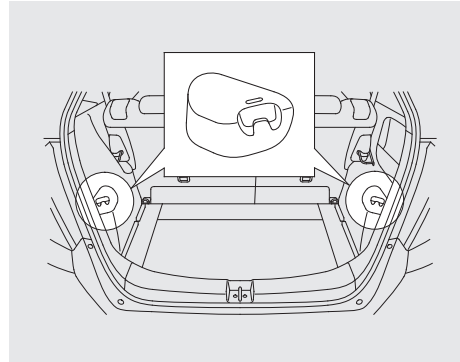

Your vehicle also has cargo hooks on side panel in the cargo area. They are designed to hold light items. Heavy objects may damage the hook. Make sure any items put on each hook weigh less than 2.2 lbs (1 kg).

This section gives you tips on starting the engine under various conditions, and how to operate the manual and automatic transmissions. It also includes important information on parking your vehicle, the braking system, the vehicle stability assist (VSA[®]), and the tire pressure monitoring system (TPMS).

Driving Guidelines.....	214
Preparing to Drive	215
Starting the Engine	216
Manual Transmission	217
Automatic Transmission	219
Driving with the Paddle Shifters (Sport only)	224
Parking	229
Braking System	230
Anti-lock Brakes (ABS)	231
Vehicle Stability Assist (VSA [®]), aka Electronic Stability Control (ESC), System.....	233
Tire Pressure Monitoring System (TPMS).....	235
Towing a Trailer.....	238
Towing Your Vehicle Behind a Motorhome	238

Driving Guidelines

On Sport model

Your vehicle is designed to give you optimum handling and performance on well-maintained roads. As part of this design, your vehicle has minimum ground clearance.

- Use caution if you ever drive your vehicle on very rough or rutted roads. You could damage the suspension and underbody by bottoming out. Going too fast over parking lot “speed bumps” can also cause damage.

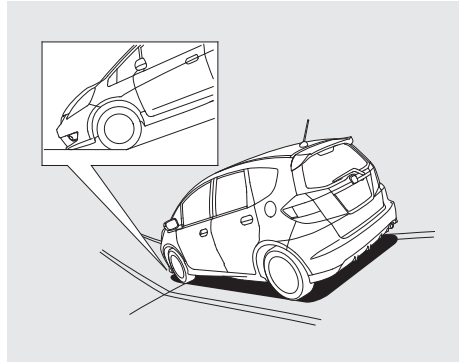

- Curbs and steep inclines could damage the front and rear bumpers. Low curbs that do not affect the average vehicle may be high enough to hit the bumper on your vehicle. The front or rear bumper may scrape when trying to drive onto an incline, such as a steep driveway or trailer ramps.

You should do the following checks and adjustments before you drive your vehicle.

1. Make sure all windows, mirrors, and outside lights are clean and unobstructed. Remove frost, snow, or ice.
2. Check that the hood is fully closed.
3. Visually check the tires. If a tire looks low, use a gauge to check its pressure (see page 273).
4. Check that any items you may be carrying are stored properly or fastened down securely.
5. Check the seat adjustment (see page 93).
6. Check the adjustment of the inside and outside mirrors (see page 101).
7. Check the steering wheel adjustment (see page 77).
8. Make sure the doors and the tailgate are securely closed and locked.
9. Fasten your seat belt. Check that your passengers have fastened their seat belts (see page 14).
10. When you start the engine, check the gauges and indicators in the instrument panel (see page 59).

Starting the Engine

1. Apply the parking brake.
2. In cold weather, turn off all electrical accessories to reduce the drain on the battery.
3. *Manual transmission:*
Press the clutch pedal down all the way. The START (III) position does not function unless the clutch pedal is pressed.

Automatic transmission:

Make sure the shift lever is in Park. Press on the brake pedal.

4. Without touching the accelerator pedal, turn the ignition key to the START (III) position. Do not hold the key in the START (III) position for more than 15 seconds at a time. If the engine does not start right away, pause for at least 10 seconds before trying again.

NOTICE

The immobilizer system protects your vehicle from theft. If an improperly-coded key (or other device) is used, the engine's fuel system is disabled. For more information, see page 79.

5. If the engine does not start within 15 seconds, or starts but stalls right away, repeat step 4 with the accelerator pedal pressed halfway down. If the engine starts, release pressure on the accelerator pedal so the engine does not race.

6. If the engine fails to start, press the accelerator pedal all the way down, and hold it there while starting to clear flooding. If the engine still does not start, return to step 5.

NOTICE

The engine is harder to start in cold weather. Also, the thinner air found at altitudes above 8,000 feet (2,400 meters) adds to this problem.

Manual Transmission

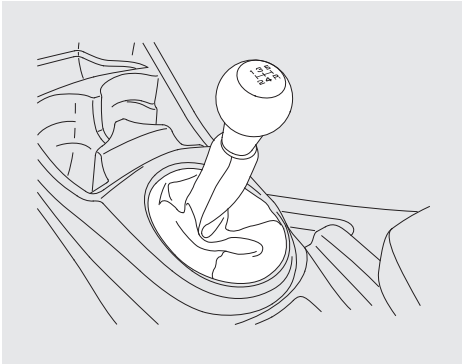

The manual transmission is synchronized in all forward gears for smooth operation. It has a lockout so you cannot shift directly from fifth to reverse. When shifting up or down, make sure you push the clutch pedal down all the way, shift to the next gear, and let the pedal up gradually. When you are not shifting, do not rest your foot on the clutch pedal. This can cause the clutch to wear out faster.

Come to a full stop before you shift into reverse. You can damage the transmission by trying to shift into reverse with the vehicle moving. Push down the clutch pedal, and pause for a few seconds before shifting into reverse, or shift into one of the forward gears for a moment. This stops the gears so they won't "grind."

When slowing down, you can get extra braking from the engine by shifting to a lower gear. This extra braking can help you maintain a safe speed and prevent your brakes from overheating while going down a steep hill. Before downshifting, make sure the engine speed will not go into the tachometer's red zone in the lower gear.

⚠ WARNING

Rapid slowing or speeding up can cause loss of control on slippery surfaces. If you crash, you can be injured.

Use extra care when driving on slippery surfaces.

Manual Transmission

Recommended Shift Points

Drive in the highest gear that lets the engine run and accelerate smoothly. This will give you good fuel economy and effective emissions control. The following shift points are recommended:

Shift up	Normal acceleration
1st to 2nd	15 mph (24 km/h)
2nd to 3rd	27 mph (44 km/h)
3rd to 4th	39 mph (63 km/h)
4th to 5th	53 mph (85 km/h)

Engine Speed Limiter

If you exceed the maximum speed for the gear you are in, the engine speed will enter into the tachometer's red zone. If this occurs, you may feel the engine cut in and out. This is caused by a limiter in the engine's computer controls. The engine will run normally when you reduce the rpm below the red zone.

The engine speed limiter only works when you upshift; engine speed is not limited during downshifts. Before downshifting, make sure the engine will not go into the tachometer's red zone.

Shift Lever Position Indicators

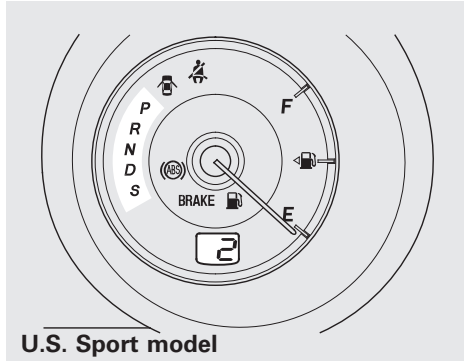

These indicators on the instrument panel show which position the shift lever is in.

The “D” indicator comes on for a few seconds when you turn the ignition switch to the ON (II) position. If it flashes while driving (in any shift position), it indicates a possible problem in the transmission.

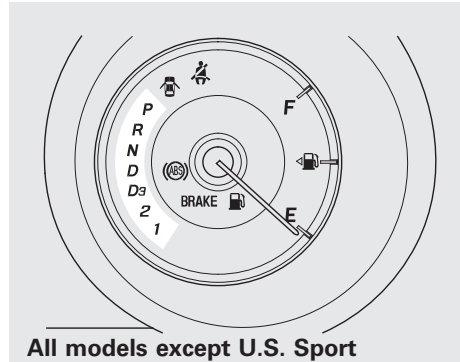

All models except U.S. Sport

If the malfunction indicator lamp comes on along with the “D” indicator, there is a problem with the automatic transmission control system. Avoid rapid acceleration, and have the transmission checked by your dealer as soon as possible.

Shifting

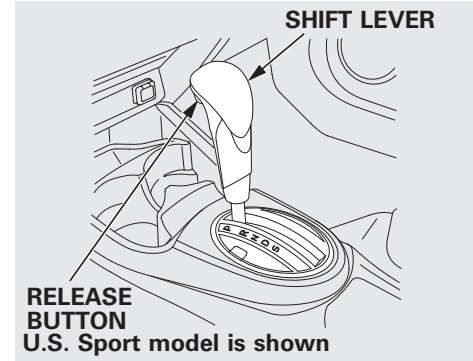

To shift from Park to any position, press firmly on the brake pedal and press the release button on the front of the shift lever, then pull the lever. You cannot shift out of Park when the ignition switch is in the LOCK (0) or the ACCESSORY (I) position.

Automatic Transmission

All models except U.S. Sport

To shift from:	Do this:
P to R	Press the brake pedal, and press the shift lever release button.
R to P N to R D ₃ to 2 2 to 1	Press the shift lever release button.
1 to 2 2 to D ₃ D ₃ to D D to N D to D ₃ N to D R to N	Move the shift lever.

U.S. Sport model

To shift from:	Do this:
P to R	Press the brake pedal, and press the shift lever release button.
R to P N to R D to S	Press the shift lever release button.
S to D D to N N to D R to N	Move the shift lever.

Park (P) – This position mechanically locks the transmission. Use Park whenever you are turning off or starting the engine. To shift out of Park, you must press on the brake pedal and have your foot off the accelerator pedal. Press the release button on the front of the shift lever to move it.

If you have done all of the above and still cannot move the lever out of Park, see **Shift Lock Release** on page 223.

To avoid transmission damage, come to a complete stop before shifting into Park. You must also press the release button to shift into Park. The shift lever must be in Park before you can remove the key from the ignition switch.

Automatic Transmission

Reverse (R) – Press the brake pedal and press the release button on the front of the shift lever to shift from Park to reverse. To shift from reverse to neutral, come to a complete stop, and then shift. Press the release button before shifting into reverse from neutral.

Neutral (N) – Use neutral if you need to restart a stalled engine, or if it is necessary to stop briefly with the engine idling. Shift to the Park position if you need to leave your vehicle for any reason. Press on the brake pedal when you are moving the shift lever from neutral to another gear.

Drive (D) – Use this position for your normal driving. The transmission automatically selects a suitable gear (1 through 5) for your speed and acceleration. You may notice the transmission shifting up at higher engine speeds when the engine is cold. This helps the engine warm up faster.

All models except U.S. Sport

Drive (D3) – This position is similar to D, except only the first three gears are selected. Use D3 to provide engine braking when going down a steep hill. D3 can also keep the transmission from cycling between third and fourth gears in stop-and-go driving.

All models except U.S. Sport

Second (2) – To shift to second, press the release button on the front of the shift lever. This position locks the transmission in second gear. It does not downshift to first gear when you come to a stop.

Use second gear:

- For more power when climbing.
- To increase engine braking when going down steep hills.
- For starting out on a slippery surface or in deep snow.
- To help reduce wheel spin.

CONTINUED

Automatic Transmission

All models except U.S. Sport

First (1) – To shift from second to first, press the release button on the front of the shift lever. This position locks the transmission in first gear. By upshifting and downshifting through 1, 2, D3, and D, you can operate the transmission much like a manual transmission without a clutch pedal.

U.S. Sport model

S position (S) – To shift into the S position, press the release button on the front of the shift lever, and move the lever to S. This position is similar to D, except only first to fourth gears are selected and fifth gear is no longer available. However, during most driving conditions, only first through third gears are used.

With the shift lever in D or S, you can also use the paddle shifters to shift the transmission up or down. With the paddle shifters, you can operate the transmission much like a manual transmission without a clutch pedal. For more information on driving with the paddle shifters, see page 224.

Engine Speed Limiter

If you exceed the maximum speed for the gear you are in, the engine speed will enter into the tachometer's red zone. If this occurs, you may feel the engine cut in and out. This is caused by a limiter in the engine's computer controls. The engine will run normally when you reduce the rpm below the red zone.

Shift Lock Release

This allows you to move the shift lever out of Park if the normal method of pushing on the brake pedal and pressing the release button does not work.

1. Set the parking brake.
2. Remove the key from the ignition switch.
3. Put a cloth on the notch of the shift lock release slot cover to prevent scratches. Using a small flat-tip screwdriver or a metal fingernail file, carefully pry on the notch of the cover to remove it.

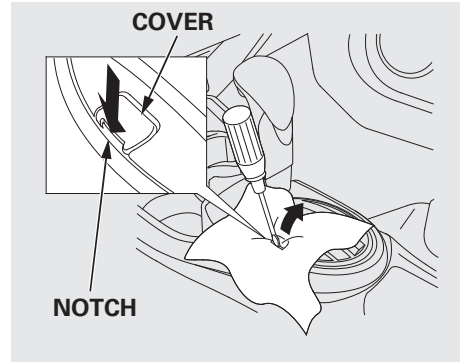

4. Insert the key in the shift lock release slot.
5. Push down on the key while you press the release button on the shift lever and move the shift lever out of Park to neutral.

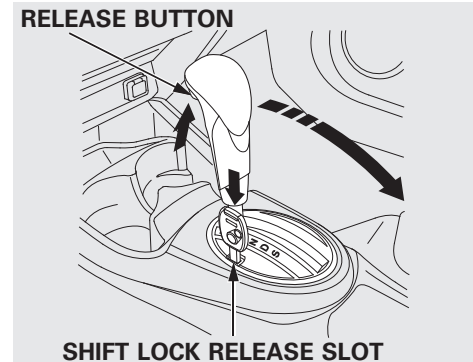

6. Remove the key from the shift lock release slot, then reinstall the cover. Make sure the notch on the cover is on the left side. Insert the key back into the ignition switch, press the brake pedal, and restart the engine.

If you need to use the shift lock release, it means your vehicle is developing a problem. Have it checked by your dealer.

Driving with the Paddle Shifters (Sport only)

Using the Paddle Shifters in D position (D-Paddle Shift Mode)

U.S. models only

When you are driving in D position, you can shift the transmission up or down manually with the paddle shifters.

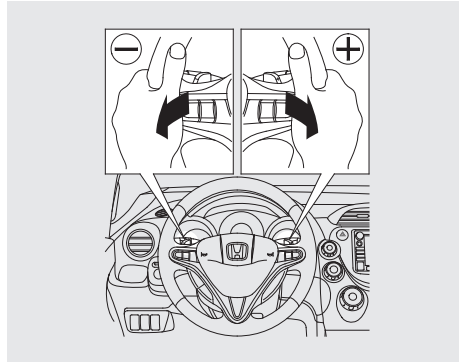

To shift up or down, use the + (right) or - (left) paddle shifter on each side of the steering wheel.

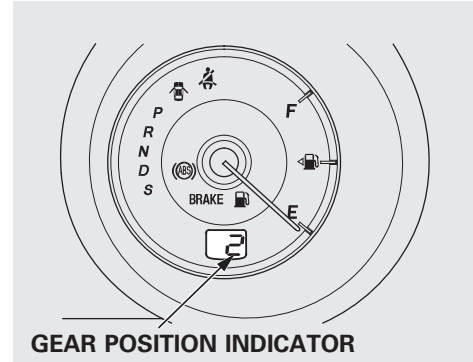

Each time you pull the + (right) paddle, the transmission shifts to a higher gear. Pull the - (left) paddle to downshift. You will see the selected gear number on the instrument panel.

When you pull either paddle shifter, the gear position indicator shows you the selected gear number.

When the transmission returns to drive mode (D), the displayed gear number disappears.

Driving with the Paddle Shifters (Sport only)

Downshifting with the paddle shifter allows you to increase the engine braking when going down steep or long hills, and provides more power when climbing uphill. You can upshift the transmission manually to reduce the rpm. Driving in the higher gear helps fuel economy.

The transmission control system monitors the accelerator pedal use and your driving conditions. When you press the accelerator pedal as in normal driving, the system judges that you are driving at a constant cruising speed without using the paddle shifters. Under these conditions, D-paddle shift mode is canceled, and the transmission automatically returns to drive mode (D).

The transmission remains in the selected gear if you do not accelerate.

Each time you pull either paddle shifter, the transmission shifts one gear up or down. If you want to shift up or down more than two gears, pull the paddle shifter twice, pause, and then pull it again.

The automatic transmission will not allow you to shift up or down if:

- You downshift before the engine speed reaches the highest threshold of the lower gear.

If you try to do this, the gear position indicator will flash the number of the lower gear several times, then return to a higher gear.

- You upshift before the engine speed reaches the lowest threshold of the higher gear.
- You pull both paddle shifters at the same time.

The transmission downshifts to first gear and returns to drive mode (D) when the vehicle comes to a complete stop or the vehicle speed is about 6 mph (10 km/h).

CONTINUED

Driving with the Paddle Shifters (Sport only)

When you pull and hold the + (right) paddle shifter, the transmission automatically returns to drive mode (D).

If there is a problem in the transmission while you are driving with the paddle shifters, the D indicator flashes, the D-paddle shift mode is canceled, and the transmission returns to drive mode (D).

Using the Paddle Shift in S position (Sequential Shift Mode)

U.S. models only

With the shift lever in the S position, you can manually shift up or down with the paddle shifters. The transmission goes into the sequential shift mode and holds the selected gear.

To enter the sequential shift mode, press the release button on the front of the shift lever, move the lever to the S position, then pull either paddle shifter. To return to drive mode (D), move the shift lever to the D position. While you are driving in the sequential shift mode, the transmission will not automatically return to drive mode (D).

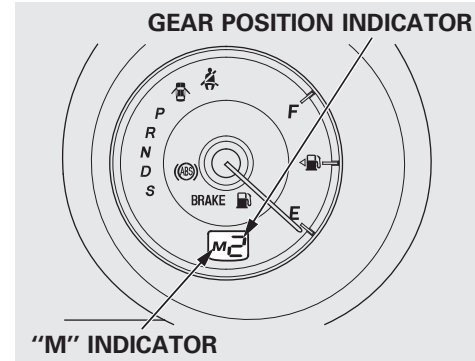

When you move the shift lever from “D” to the “S” position and pull either paddle shifter, the gear position indicator displays “M” along with the selected gear number.

To upshift, pull the + (right) paddle shifter. To downshift, pull the – (left) paddle shifter.

Driving with the Paddle Shifters (Sport only)

When you accelerate from a stop, the transmission starts in first gear, and you must manually upshift between first and fifth gears. Make sure you upshift before the engine speed reaches the tachometer's red zone.

The transmission remains in the selected gear (5, 4, 3, 2, or 1). There is no automatic downshift when you push the accelerator pedal to the floor.

When you are driving in 4th or 5th gear, the transmission downshifts to the lower gear under the following conditions:

- The vehicle slows down to a certain speed.
- You press the brake pedal.

Downshifting with the paddle shifter allows you to increase the engine braking when going down steep or long hills, and provides more power when climbing uphill. You can upshift the transmission manually to reduce the rpm. Driving in the higher gear helps fuel economy.

The transmission also shifts automatically as the vehicle comes to a complete stop. It downshifts to first gear when the vehicle speed reaches 6 mph (10 km/h) or less.

The automatic transmission will not allow you to shift up or down if:

- You downshift before the engine speed reaches the highest threshold of the lower gear.

If you try to do this, the gear position indicator will flash the number of the lower gear several times, then return to a higher gear.

CONTINUED

Driving with the Paddle Shifters (Sport only)

If the vehicle speed decreases below the redline of the selected lower gear while the indicator is flashing, the transmission downshifts, and the indicator displays the selected gear.

- You upshift before the engine speed reaches the lowest threshold of the higher gear.
- You pull both paddle shifters at the same time.

Starting in Second Gear

When you are in sequential shift mode, and the vehicle is stopped, pull the + (right) paddle shifter to shift to second gear. You will see “M2” in the display. Starting in second gear helps to reduce wheelspin in deep snow or on a slippery surface.

Recommended Shift Points

Drive in the highest gear that lets the engine run and accelerate smoothly. This will give you good fuel economy and effective emissions control. The following shift points are recommended:

Shift up	Normal acceleration
1st to 2nd	15 mph (24 km/h)
2nd to 3rd	25 mph (40 km/h)
3rd to 4th	40 mph (64 km/h)
4th to 5th	47 mph (76 km/h)

Always use the parking brake when you park your vehicle. Make sure the parking brake is set firmly, or your vehicle may roll if it is parked on an incline.

If your vehicle has an automatic transmission, set the parking brake before you put the transmission in Park. This keeps the vehicle from moving and putting pressure on the parking mechanism in the transmission.

Parking Tips

- Make sure the windows are closed.
- Turn off the lights.
- Place any packages, valuables, etc. in the cargo area or take them with you.
- Lock the doors and the tailgate.

On Sport model

Check the indicator on the instrument panel to verify that the security system is set.

- Never park over dry leaves, tall grass, or other flammable materials. The hot three way catalytic converter could cause these materials to catch on fire.

- If the vehicle is facing uphill, turn the front wheels away from the curb. If your vehicle has a manual transmission, put it in first gear and set the parking brake.
- If the vehicle is facing downhill, turn the front wheels toward the curb. If your vehicle has a manual transmission, put it in reverse gear and set the parking brake.
- Make sure the parking brake is fully released before driving away. Driving with the parking brake partially set can overheat or damage the rear brakes.

Braking System

Your vehicle is equipped with front disc brakes. The brakes on the rear wheels are drum. A power assist helps reduce the effort needed on the brake pedal. The anti-lock brake system (ABS) helps you retain steering control when braking very hard.

Resting your foot on the pedal keeps the brakes applied lightly, builds up heat, and reduces their effectiveness and reduces brake pad life. In addition, fuel economy can be reduced. It also keeps your brake lights on all the time, confusing drivers behind you.

Constant application of the brakes when going down a long hill builds up heat and reduces their effectiveness. Use the engine to assist the brakes by taking your foot off the accelerator and downshifting to a lower gear.

Check your brakes after driving through deep water. Apply the brakes moderately to see if they feel normal. If not, apply them gently and frequently until they do. Be extra cautious and alert in your driving.

Braking System Design

The hydraulic system that operates the brakes has two separate circuits. Each circuit works diagonally across the vehicle (the left-front brake is connected with the right-rear brake, etc.). If one circuit should develop a problem, you will still have braking at two wheels.

Brake Pad Wear Indicators

If the front brake pads need replacing, you will hear a distinctive, metallic screeching sound when you apply the brake pedal. If you do not have the brake pads replaced, they will screech all the time. It is normal for the brakes to occasionally squeal or squeak when you apply them.

Anti-lock Brakes (ABS)

The anti-lock brake system (ABS) helps prevent the wheels from locking up, and helps you retain steering control by pumping the brakes rapidly, much faster than a person can do it.

The electronic brake distribution (EBD) system, which is part of the ABS, also balances the front-to-rear braking distribution according to vehicle loading.

You should never pump the brake pedal. Let the ABS work for you by always keeping firm, steady pressure on the brake pedal. This is sometimes referred to as “stomp and steer.”

You will feel a pulsation in the brake pedal when the ABS activates, and you may hear some noise. This is normal: it is the ABS rapidly pumping the brakes. On dry pavement, you will need to press on the brake pedal very hard before the ABS activates. However, you may feel the ABS activate immediately if you are trying to stop on snow or ice.



ABS Indicator

If the ABS indicator comes on, the anti-lock function of the braking system has shut down. The brakes still work like a conventional system, but without anti-lock. You should have your dealer inspect your vehicle as soon as possible.

If the ABS indicator comes on while driving, test the brakes as shown on page 305.

CONTINUED

Anti-lock Brakes (ABS)

If the ABS indicator and the brake system indicator come on together, and the parking brake is fully released, the EBD system may also be shut down.

Test your brakes as instructed on page 305. If the brakes feel normal, drive slowly and have your vehicle repaired by your dealer as soon as possible. Avoid sudden hard braking which could cause the rear wheels to lock up and possibly lead to a loss of control.

On vehicles with VSA system

The VSA indicator will come on along with the ABS indicator.

Important Safety Reminders

ABS does not reduce the time or distance it takes to stop the vehicle. It only helps with the steering control during braking.

ABS will not prevent a skid that results from changing direction abruptly, such as trying to take a corner too fast or making a sudden lane change. Always drive at a safe speed for the road and weather conditions.

ABS cannot prevent a loss of stability. Always steer moderately when you are braking hard. Severe or sharp steering wheel movement can still cause your vehicle to veer into oncoming traffic or off the road.

A vehicle with ABS may require a longer distance to stop on loose or uneven surfaces, such as gravel or snow, than a vehicle without anti-lock.

Vehicle Stability Assist (VSA®), aka Electronic Stability Control (ESC), System

If equipped

The vehicle stability assist (VSA) system helps to stabilize the vehicle during cornering if the vehicle turns more or less than desired. It also assists you in maintaining traction while accelerating on loose or slippery road surfaces. It does this by regulating the engine's output and by selectively applying the brakes.

When VSA activates, you may notice that the engine does not respond to the accelerator in the same way it does at other times. There may also be some noise from the VSA hydraulic system. You will also see the VSA system indicator blink.

The VSA system cannot enhance the vehicle's driving stability in all situations and does not control your vehicle's entire braking system. It is still your responsibility to drive and corner at reasonable speeds and to leave a sufficient margin of safety.



VSA Off Indicator

When VSA is off, the VSA off indicator comes on as a reminder.



Vehicle Stability Assist (VSA) System Indicator

When VSA activates, you will see the VSA system indicator blink.

If this indicator comes on while driving, pull to the side of the road when it is safe, and turn off the engine. Reset the system by restarting the engine. If the VSA system indicator stays on or comes back on while driving, have the VSA system inspected by your dealer.

NOTE: The main function of the VSA system is generally known as Electronic Stability Control (ESC). The system also includes a traction control function.

If the indicator does not come on when the ignition switch is turned to the ON (II) position, there may be a problem with the VSA system. Have your dealer inspect your vehicle as soon as possible.

If the low tire pressure indicator or TPMS indicator comes on, the VSA system automatically turns on even if the VSA system is turned off by pressing the VSA OFF switch (see page 234). If this happens, you cannot turn the VSA system off by pressing the VSA OFF switch again.

Without VSA, your vehicle will have normal braking and cornering ability, but it will not have VSA traction and stability enhancement.

CONTINUED

Vehicle Stability Assist (VSA®), aka Electronic Stability Control (ESC), System

VSA OFF Switch

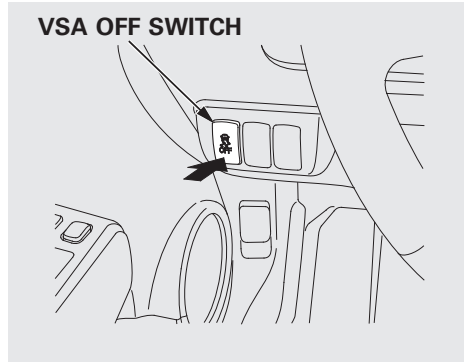

This switch is under the driver's side beverage holder. To turn the VSA system on and off, press and hold it until you hear a beep.

When VSA is off, the VSA off indicator comes on as a reminder. Press and hold the switch again. It turns the system back on.

VSA is turned on every time you start the engine, even if you turned it off the last time you drove the vehicle.

In certain unusual conditions when your vehicle gets stuck in shallow mud or fresh snow, it may be easier to free it with the VSA temporarily switched off. When the VSA system is off, the traction control system is also off. You should only attempt to free your vehicle with the VSA off if you are not able to free it when the VSA is on.

Immediately after freeing your vehicle, be sure to switch the VSA on again. We do not recommend driving your vehicle with the VSA and traction control systems switched off.

VSA and Tire Sizes

Driving with varying tire or wheel sizes may cause the VSA to malfunction. When replacing tires, make sure they are the same size and type as your original tires (see page 277).

If you install winter tires, make sure they are the same size as those that were originally supplied with your vehicle. Exercise the same caution during winter driving as you would if your vehicle was not equipped with VSA.

Tire Pressure Monitoring System (TPMS)

U.S. models only

Your vehicle is equipped with a tire pressure monitoring system (TPMS) that turns on every time you start the engine and monitors the pressure in your tires while driving.

Each tire has its own pressure sensor (not including the spare tire). If the air pressure of a tire becomes significantly low, the sensor in that tire immediately sends a signal that causes the low tire pressure indicator to come on.



Low Tire Pressure Indicator

When the low tire pressure indicator is on, one or more of your tires is significantly underinflated. You should stop and check your tires as soon as possible, and inflate them to the proper pressure as indicated on the vehicle's tire information placard.

If you think you can safely drive a short distance to a service station, proceed slowly, and inflate the tire to the recommended pressure shown on the driver's doorjamb.

If the tire is flat, or if the tire pressure is too low to continue driving, replace the tire with the compact spare tire (see page 284).

If you cannot make the low tire pressure indicator go out after inflating the tires to the specified values, have your dealer check the system as soon as possible.

Driving on a significantly underinflated tire causes the tire to overheat and can lead to tire failure. Under-inflation also reduces fuel efficiency and tire tread life, and may affect the vehicle's handling and stopping ability.

Because tire pressure varies by temperature and other conditions, the low tire pressure indicator may come on unexpectedly.

CONTINUED

Tire Pressure Monitoring System (TPMS)

For example, if you check and fill your tires in a warm area, then drive in extremely cold weather, the tire pressure will be lower than measured and could be underinflated and cause the low tire pressure indicator to come on. Or, if you check and adjust your tire pressure in cooler conditions, and drive into extremely hot conditions, the tire may become overinflated. However, the low tire pressure indicator will not come on if the tires are overinflated.

Refer to page 273 for tire inflation guidelines.

Although your tire pressure is monitored, you must manually check the tire pressures monthly.

Each tire, including the spare, should be checked monthly when cold, and set to the recommended inflation pressure as specified on the tire information label and in the owner's manual (see page 274).

TPMS Tire Pressure Monitoring System (TPMS) Indicator

This indicator comes on and stays on if there is a problem with the tire pressure monitoring system.

If this happens, the system will shut off and no longer monitor tire pressures. Have the system checked by your dealer as soon as possible.

If the low tire pressure indicator or TPMS indicator comes on, the VSA system* automatically turns on even if the VSA system is turned off by pressing the VSA OFF switch* (see page 234). If this happens, you cannot turn the VSA system off by pressing the VSA off switch again.

*: If equipped

When you restart the vehicle with the compact spare tire, the TPMS indicator may also come on and stay on after driving several miles (kilometers).

Tire Pressure Monitoring System (TPMS)

Changing a Tire with TPMS

If you have a flat tire, the low tire pressure indicator will come on. Replace the flat tire with the compact spare tire (see page 284).

Each wheel (except the compact spare tire wheel) is equipped with a tire pressure sensor mounted inside the tire behind the valve stem. You must use TPMS specific wheels. It is recommended that you always have your tires serviced by your dealer or qualified technician.

After you replace the flat tire with the compact spare tire, the low tire pressure indicator stays on. This is normal; the system is not monitoring the spare tire pressure. Manually check the spare tire pressure to be sure it is correct. After several miles (kilometers) driving with the compact spare tire, the TPMS indicator comes on and the low tire pressure indicator goes off.

The low tire pressure indicator or the TPMS indicator will go off, after several miles (kilometers) driving, when you replace the spare tire with the specified regular tire equipped with the tire pressure monitor sensor.

Never use a puncture-repairing agent in a flat tire. If used, you will have to replace the tire pressure sensor. Have the flat tire repaired by your dealer as soon as possible.

As required by the FCC: This device complies with Part 15 of the FCC rules. Operation is subject to the following two conditions: (1) This device may not cause harmful interference, and (2) this device must accept any interference received, including interference that may cause undesired operation.

Changes or modifications not expressly approved by the party responsible for compliance could void the user's authority to operate the equipment.

This device complies with Industry Canada Standard RSS-210. Operation is subject to the following two conditions: (1) this device may not cause interference, and (2) this device must accept any interference that may cause undesired operation of the device.

Towing a Trailer, Towing Your Vehicle Behind a Motorhome

Towing a Trailer

Your vehicle is not designed to tow a trailer. Attempting to do so can void your warranties.

Towing Your Vehicle Behind a Motorhome

Your vehicle can be towed behind a motorhome at legal highway speeds up to 65 mph (100 km/h). Do not exceed 65 mph (100 km/h). Otherwise, severe transmission damage will occur.

When purchasing a tow bar, make sure you select a reputable manufacturer and installer. Follow the manufacturer's attachment instructions carefully.

NOTICE

The steering system can be damaged if the steering wheel is locked. Leave the ignition switch in the ACCESSORY (I) position, and make sure the steering wheel turns freely before you begin towing.

Automatic transmission:

Perform the following procedure every day immediately before you begin towing. Otherwise severe automatic transmission damage will occur.

1. Check the transmission fluid level (see page 259). *Do not overfill.*
2. Start the engine.
3. Press on the brake pedal. Move the shift lever through all its positions.
4. Shift to the D position and hold for 5 seconds, then to N. Let the engine run for 3 minutes, then turn it off.

NOTICE

Severe transmission damage will occur if the vehicle is shifted from reverse to neutral and then towed with the drive wheels on the ground.

Towing Your Vehicle Behind a Motorhome

5. Release the parking brake.

Manual transmission:

1. Move the shift lever into the Neutral position.
2. Release the parking brake.

Leave the ignition switch in the ACCESSORY (I) position so the steering wheel does not lock. Make sure the radio and any items plugged into the accessory power sockets are turned off so you do not run down the battery.

When you stop towing your vehicle and shift out of the neutral position, you may not be able to move the shift lever from neutral to reverse or Park. If this happens, press the brake pedal and turn the ignition switch to the ON (II) position, then shift out of neutral.

Extended Towing

If you tow more than 8 hours in one day, you should repeat the above procedure at least every 8 hours (when you stop for fuel, etc.).

NOTICE

Failure to follow the recommended instructions exactly will result in severe automatic transmission damage. If you cannot shift the transmission or start the engine, your vehicle must be transported on a flat-bed truck or trailer.

CONTINUED

Towing Your Vehicle Behind a Motorhome

When towing your vehicle for long periods, remove the 30A Radio fuse to reduce drain on battery. This fuse is located in the interior fuse box and shown as number 61 below.

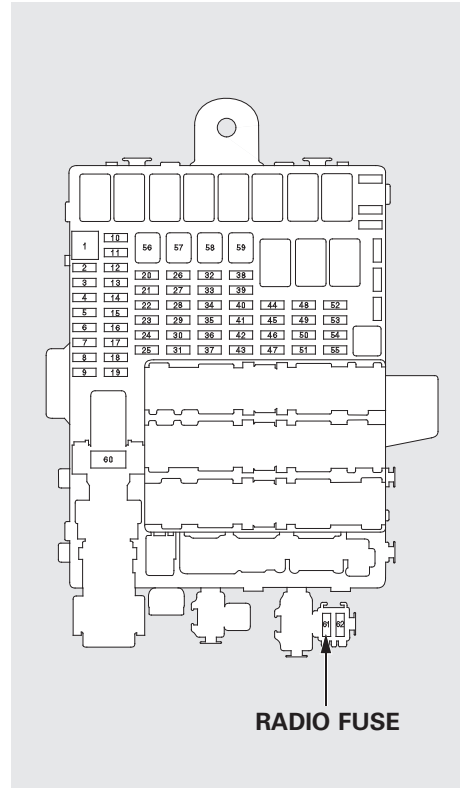

Only remove the fuse after you have performed the transmission shifting procedure, and the key is in the ACCESSORY (I) position. Store the fuse in an obvious location (center pocket, etc) as a reminder to re-install the fuse before driving the vehicle.

Towing Your Vehicle Behind a Motorhome

Automatic transmission

If you tow a Fit behind a motorhome, the transmission fluid must be changed every 2 years or 30,000 miles (48,000 km), whichever comes first.

This section explains why it is important to keep your vehicle well maintained and how to follow basic maintenance safety precautions.

This section also includes instructions on how to read the maintenance minder messages on the information display, and instructions for simple maintenance tasks you may want to take care of yourself.

If you have the skills and tools to perform more complex maintenance tasks on your vehicle, you may want to purchase the service manual. See page 335 for information on how to obtain a copy, or see your dealer.

Maintenance Safety	244
Maintenance Minder	245
Fluid Locations	252
Adding Engine Oil	253
Changing the Engine Oil and Filter	254
Engine Coolant	256
Windshield Washers	258
Transmission Fluid	259
Automatic Transmission Fluid	259
Manual Transmission Fluid	260
Brake and Clutch Fluid	261
Lights	262
Cleaning the Seat Belts	267
Floor Mats	267
Audio Antenna	268
Dust and Pollen Filter	268
Wiper Blades	269
Tires	273
Checking the Battery	279
Vehicle Storage	281

Maintenance Safety

All service items not detailed in this section should be performed by a certified technician or other qualified mechanic.

Important Safety Precautions

To eliminate potential hazards, read the instructions before you begin, and make sure you have the tools and skills required.

- Make sure your vehicle is parked on level ground, the parking brake is set, and the engine is off.
- To clean parts, use a commercially available degreaser or parts cleaner, not gasoline.
- To reduce the possibility of fire or explosion, keep cigarettes, sparks, and flames away from the battery and all fuel-related parts.
- Wear eye protection and protective clothing when working with the battery or compressed air.

WARNING

Improperly maintaining this vehicle, or failing to correct a problem before driving can cause a crash in which you can be seriously hurt or killed.

Always follow the inspection and maintenance recommendations and schedules in this owner's manual.

Potential Vehicle Hazards

- **Carbon Monoxide poison from engine exhaust.** Be sure there is adequate ventilation whenever you operate the engine.
- **Burns from hot parts.** Let the engine and exhaust system cool down before touching any parts.

- **Injury from moving parts.** Do not run the engine unless instructed to do so.

WARNING

Failure to properly follow maintenance instructions and precautions can cause you to be seriously hurt or killed.

Always follow the procedures and precautions in this owner's manual.

Some of the most important safety precautions are given here. However, we cannot warn you of every conceivable hazard that can arise in performing maintenance. Only you can decide whether or not you should perform a given task.

Your vehicle displays engine oil life and maintenance service items on the information display to show you when you should have your dealer perform engine oil replacement and indicated maintenance service.

Based on the engine operating conditions and accumulated engine revolutions, the onboard computer in your vehicle calculates the remaining engine oil life and displays it as a percentage.

Engine Oil Life Display

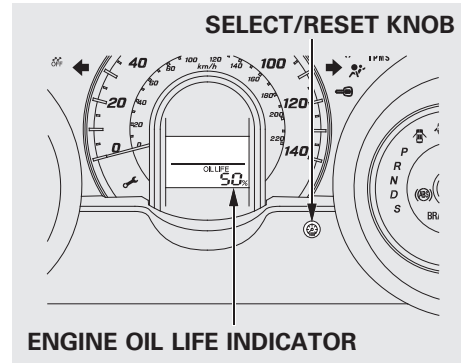

To see the current engine oil life, turn the ignition switch to the ON (II) position, then press and release the select/reset knob repeatedly until the engine oil life indicator appears (see page 68).

The remaining engine oil life is shown on the display according to this table:

Calculated Engine Oil Life (%)	Displayed Engine Oil Life (%)
100% – 91%	100%
90% – 81%	90%
80% – 71%	80%
70% – 61%	70%
60% – 51%	60%
50% – 41%	50%
40% – 31%	40%
30% – 21%	30%
20% – 16%	20%
15% – 11%	15%
10% – 6%	10%
5% – 1%	5%
0%	0%

CONTINUED

Maintenance Minder

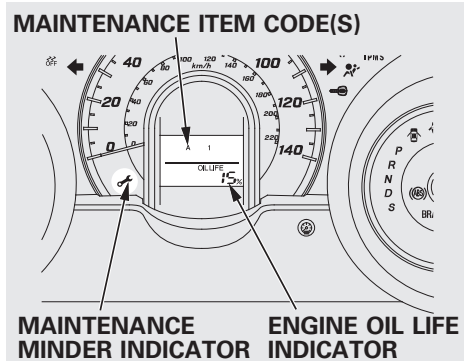

If the remaining engine oil life is 15 to 6 percent, you will see the engine oil life indicator every time you turn the ignition switch to the ON (II) position. The maintenance minder indicator will also come on, and the maintenance item code(s) for other scheduled maintenance items needing service will be displayed above the "OIL LIFE" message.

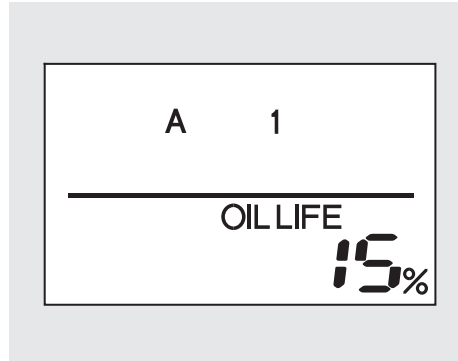

The 15 and 11 percent oil life indicator reminds you that the time is coming soon to take your vehicle in for the required maintenance.

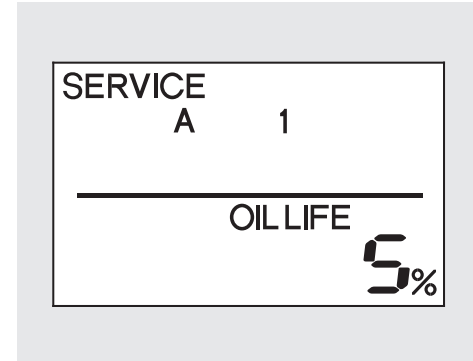

When the remaining engine oil life is 5 to 1 percent, you will see a "SERVICE" message along with the same maintenance item code(s), every time you turn the ignition switch to the ON (II) position.

Maintenance Minder

The maintenance item code or codes indicate the main and sub items required at the time of the oil change (see page 248).

You can switch the information display from the engine oil life display to the odometer or the trip meter. Press and release the select/reset knob on the instrument panel.

When the engine oil life is 15 to 1 percent, the maintenance minder indicator (🔧) comes on every time you turn the ignition switch to the ON (II) position, then it goes out if you switch the information display.

When you see this message, have the indicated maintenance performed by your dealer as soon as possible.

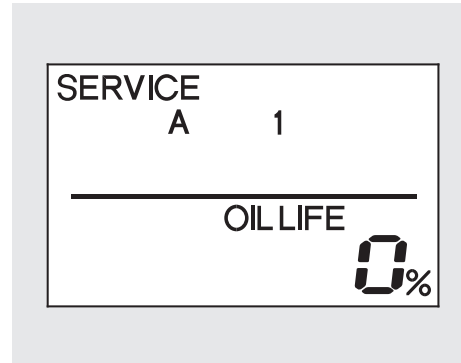

When the remaining engine oil life is 0 percent, the engine oil life indicator will blink. The display comes on every time you turn the ignition switch to the ON (II) position. The maintenance minder indicator (🔧) also comes on and remains on in the instrument panel. When you see this message, immediately have the indicated maintenance done by your dealer.

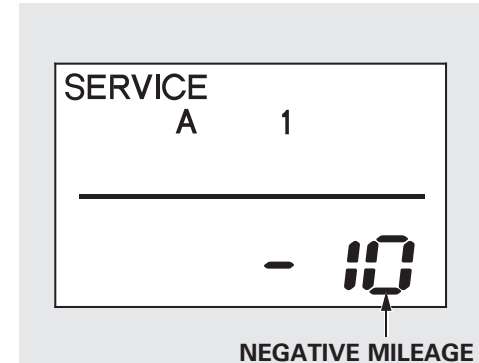

If you do not perform the indicated maintenance, negative mileage is displayed and begins to blink after the vehicle has been driven 10 miles (10 km) or more.

Negative mileage means your vehicle has passed the maintenance required point. Immediately have the indicated maintenance done by your dealer.

CONTINUED

Maintenance Minder

To change the information display from the engine oil life display to the odometer, the trip meter or average fuel mileage, press and release the select/reset knob.

When the engine oil life is 0 percent or negative mileage, the maintenance minder indicator () remains on even if you change the information display.

Immediately have the service performed, and make sure to reset the display as described.

Maintenance Main Items and Sub Items

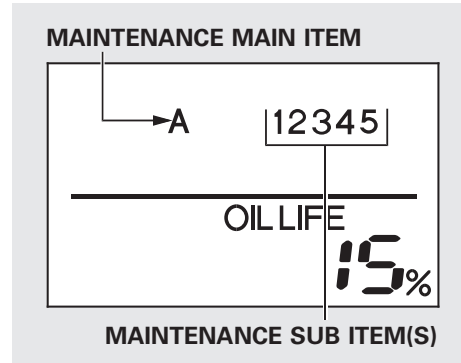

All maintenance items displayed on the information display are in code. For an explanation of these maintenance codes, see page 251.

Resetting the Engine Oil Life Display

Your dealer will reset the display after completing the required maintenance service. You will see “OIL LIFE 100%” on the information display the next time you turn the ignition switch to the ON (II) position.

If maintenance service is done by someone other than your dealer, reset the maintenance minder as follows:

1. Turn the ignition switch to the ON (II) position.
2. Press the select/reset knob repeatedly until the engine oil life is displayed.

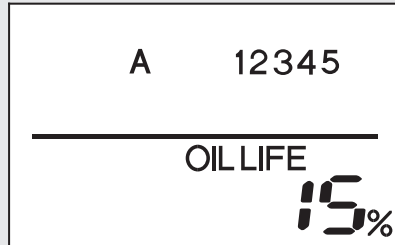

3. Press the select/reset knob for about 10 seconds. The engine oil life and the maintenance item code(s) will blink.

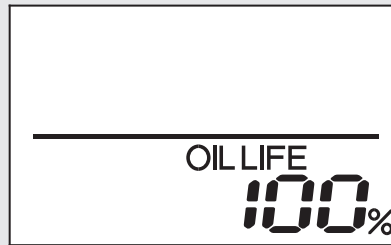

4. Press the select/reset knob for another 5 seconds. The maintenance item code(s) will disappear, and the engine oil life will reset to "100."

Important Maintenance Precautions

If you have the required service done but do not reset the display, or reset the display without doing the service, the system will not show the proper maintenance intervals. This can lead to serious mechanical problems because you will no longer have an accurate record of when maintenance is needed.

Your authorized Honda dealer knows your vehicle best and can provide competent, efficient service.

CONTINUED

Maintenance Minder

However, service at a dealer is not mandatory to keep your warranties in effect. Maintenance may be done by any qualified service facility or person who is skilled in this type of automotive service. Make sure to have the service facility or person reset the display as previously described. Keep all receipts as proof of completion, and have the person who does the work fill out your Honda Service History or Canadian Maintenance Log. Check your warranty booklet for more information.

We recommend using Honda parts and fluids whenever you have maintenance done. These are manufactured to the same high quality standards as the original components, so you can be confident of their performance and durability.

U.S. Vehicles: Maintenance, replacement, or repair of emissions control devices and systems may be done by any automotive repair establishment or individual using parts that are “certified” to EPA standards.

According to state and federal regulations, failure to perform maintenance on the items marked with # will not void your emissions warranties. However, all maintenance services should be performed in accordance with the intervals indicated by the information display.

Owner's Maintenance Checks

You should check the following items at the specified intervals. If you are unsure of how to perform any check, turn to the appropriate page listed.

- Engine oil level – Check every time you fill the fuel tank. See page 201.
- Engine coolant level – Check the radiator reserve tank every time you fill the fuel tank. See page 202.
- Automatic transmission – Check the fluid level monthly. See page 259.
- Brakes – Check the fluid level monthly. See page 261.
- Tires – Check the tire pressure monthly. Examine the tread for wear and foreign objects. See page 274.
- Lights – Check the operation of the headlights, parking lights, taillights, high-mount brake light, and license plate lights monthly. See page 262.

Maintenance Minder

Symbol	Maintenance Main Items
A	<ul style="list-style-type: none"> • Replace engine oil*¹
B	<ul style="list-style-type: none"> • Replace engine oil and oil filter • Inspect front and rear brakes • Check parking brake adjustment • Inspect these items: <ul style="list-style-type: none"> • Tie rod ends, steering gear box, and boots • Suspension components • Driveshaft boots • Brake hoses and lines (including ABS/VSA) • All fluid levels and condition of fluids • Exhaust system[#] • Fuel lines and connections[#] • Check expiration date for TRK bottle*²

*1: If the message "SERVICE" does not appear more than 12 months after the display is reset, change the engine oil every year.

*2: Canadian A/T models only

#: See information on maintenance and emissions warranty on page 249.

- NOTE:
- Independent of maintenance messages in the information display, replace the brake fluid every 3 years.
 - Inspect idle speed every 160,000 miles (256,000 km).
 - Adjust the valves during services A, B, 1, 2, or 3 only if they are noisy.

Symbol	Maintenance Sub Items
1	<ul style="list-style-type: none"> • Rotate tires
2	<ul style="list-style-type: none"> • Replace air cleaner element If you drive in dusty conditions, replace every 15,000 miles (24,000 km). • Replace dust and pollen filter If you drive primarily in urban areas that have high concentrations of soot in the air from industry and from diesel-powered vehicles, replace every 15,000 miles (24,000 km). • Inspect drive belt
3	<ul style="list-style-type: none"> • Replace transmission fluid Driving in mountainous areas at very low vehicle speeds results in higher transmission temperatures. This requires transmission fluid changes more frequently than recommended by the maintenance minder. If you regularly drive your vehicle under these conditions, have the transmission fluid changed at 60,000 miles (100,000 km), then every 30,000 miles (48,000 km). (For A/T only) If you tow a Fit behind a motorhome, the transmission fluid must be changed every 2 years or 30,000 miles (48,000 km), whichever comes first. (For A/T only)
4	<ul style="list-style-type: none"> • Replace spark plugs • Inspect valve clearance
5	<ul style="list-style-type: none"> • Replace engine coolant

Fluid Locations

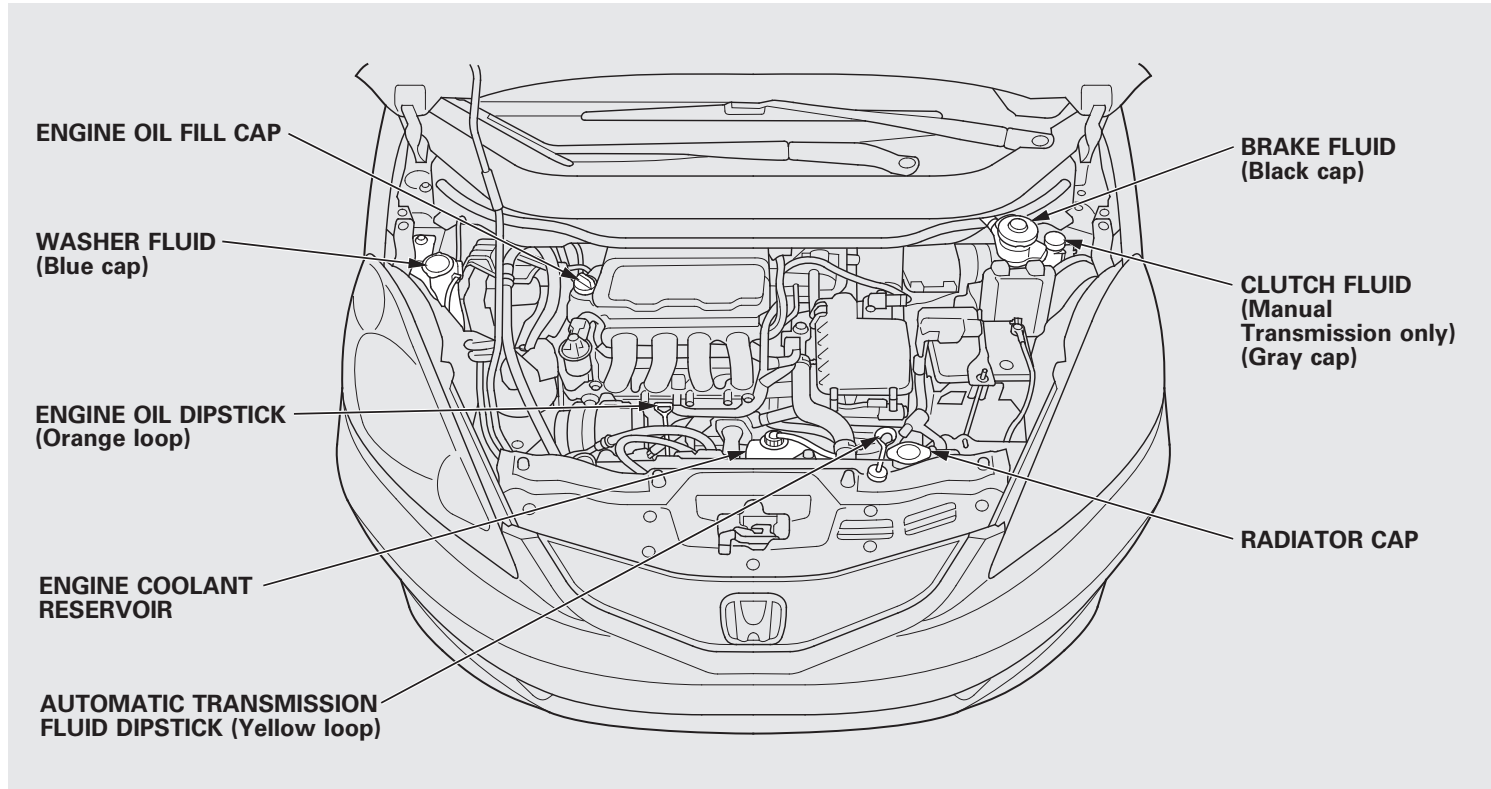

Adding Engine Oil

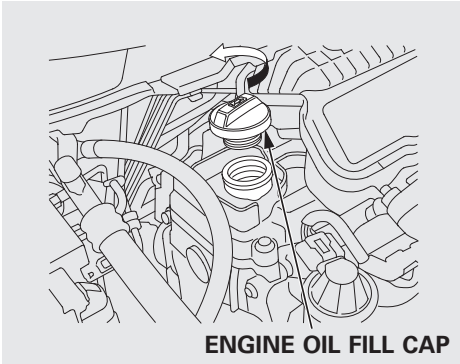

Unscrew and remove the engine oil fill cap on the valve cover. Pour in the oil slowly and carefully so you do not spill any. Clean up any spills immediately. Spilled oil could damage components in the engine compartment.

Reinstall the engine oil fill cap, and tighten it securely. Wait a few minutes, and recheck the oil level on the engine oil dipstick. Do not fill above the upper mark; you could damage the engine.

Recommended Engine Oil

Oil is a major contributor to your engine's performance and longevity. Always use a premium-grade 5W-20 detergent oil displaying the API Certification Seal. This seal indicates the oil is energy conserving, and that it meets the American Petroleum Institute's latest requirements.

API CERTIFICATION SEAL



Honda Motor Oil is the preferred 5W-20 lubricant for your vehicle. It is highly recommended that you use Honda Motor Oil in your vehicle for optimum engine protection. Make sure the API Certification Seal says "For Gasoline Engines."

The oil viscosity or weight is provided on the container's label. 5W-20 oil is formulated for year-round protection of your vehicle to improve cold weather starting and fuel economy.

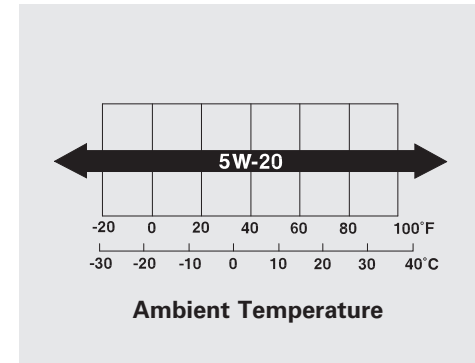

CONTINUED

Adding Engine Oil, Changing the Engine Oil and Filter

Synthetic Oil

You may use a synthetic motor oil if it meets the same requirements given for a conventional motor oil, it displays the API Certification Seal, and it is the proper weight. You must follow the oil and filter change intervals shown on the information display.

Engine Oil Additives

Your vehicle does not require any oil additives. Additives may adversely affect the engine or transmission performance and durability.

Changing the Engine Oil and Filter

Always change the oil and filter according to the maintenance messages shown on the information display. The oil and filter collect contaminants that can damage your engine if they are not removed regularly.

Changing the oil and filter requires special tools and access from underneath the vehicle. The vehicle should be raised on a service station-type hydraulic lift for this service. Unless you have the knowledge and proper equipment, you should have this maintenance done by a skilled mechanic.

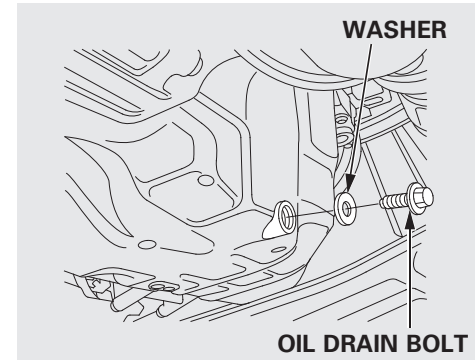

1. Run the engine until it reaches normal operating temperature, then shut it off.
2. Open the hood, and remove the engine oil fill cap. Remove the oil drain bolt and washer from the bottom of the engine. Drain the oil into an appropriate container.

Changing the Engine Oil and Filter

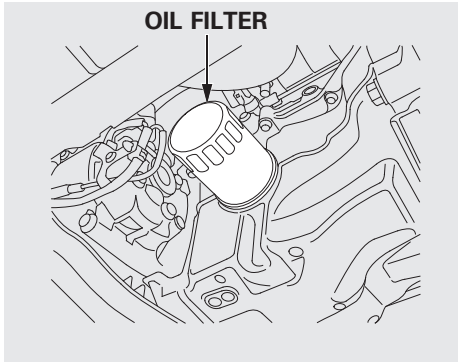

3. Remove the oil filter, and let the remaining oil drain. A special wrench (available from your dealer) is required.

Make sure the oil filter gasket is not stuck to the engine block. If it is, remove it before installing a new oil filter.

4. Install a new oil filter according to the instructions that come with it. Make sure to clean off any dirt and dust on the connecting surface of a new oil filter.

5. Put a new washer on the drain bolt, then reinstall the drain bolt. Tighten the drain bolt to:
29 lbf·ft (39 N·m, 4.0 kgf·m)
6. Refill the engine with the recommended oil.

Engine oil change capacity
(including filter):
3.8 US qt (3.6 L)

7. Replace the engine oil fill cap. Start the engine. The oil pressure indicator should go out within 5 seconds. If it does not, turn off the engine, and check your work.
8. Let the engine run for several minutes, then check the drain bolt and oil filter for leaks.
9. Turn off the engine, let it sit for several minutes, then check the oil level on the dipstick. If necessary, add more oil.

NOTICE

Improper disposal of engine oil can be harmful to the environment. If you change your own oil, please dispose of the used oil properly. Put it in a sealed container and take it to a recycling center. Do not discard it in a trash bin or dump it on the ground.

Engine Coolant

Adding Engine Coolant

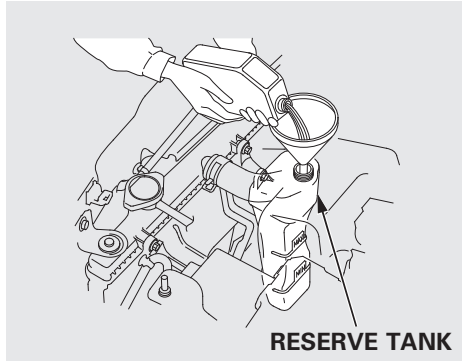

If the coolant level in the reserve tank is at or below the MIN line, add coolant to bring it up to the MAX line. Inspect the cooling system for leaks.

Always use Honda Long-life Antifreeze/Coolant Type 2. This coolant is pre-mixed with 50 percent antifreeze and 50 percent water. Never add straight antifreeze or plain water.

If Honda antifreeze/coolant is not available, you may use another major-brand non-silicate coolant as a temporary replacement. Make sure it is a high-quality coolant recommended for aluminum engines. Continued use of any non-Honda coolant can result in corrosion, causing the cooling system to malfunction or fail. Have the cooling system flushed and refilled with Honda antifreeze/coolant as soon as possible.

If the reserve tank is completely empty, you should also check the coolant level in the radiator.

⚠ WARNING

Removing the radiator cap while the engine is hot can cause the coolant to spray out, seriously scalding you.

Always let the engine and radiator cool down before removing the radiator cap.

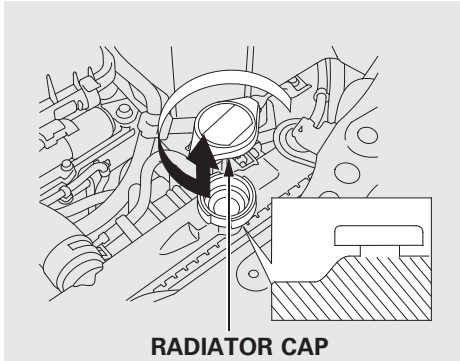

1. Make sure the engine and radiator are cool.
2. Relieve any pressure in the cooling system by turning the radiator cap counterclockwise, without pressing down.
3. Remove the radiator cap by pushing down and turning counterclockwise.

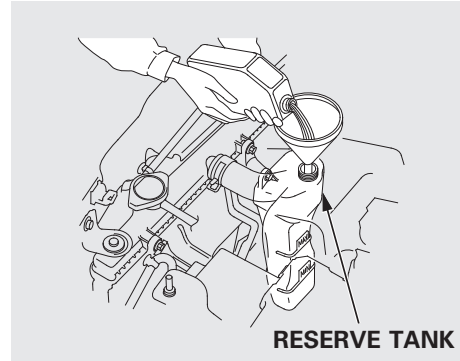

4. The coolant level should be up to the base of the filler neck. Add coolant if it is low.

Pour the coolant slowly and carefully so you do not spill any. Clean up any spill immediately; it could damage components in the engine compartment.

5. Put the radiator cap back on, and tighten it fully.

6. Pour coolant into the reserve tank. Fill it halfway between the MAX and MIN marks. Put the cap back on the reserve tank.

Do not add any rust inhibitors or other additives to your vehicle's cooling system. They may not be compatible with the coolant or engine components.

Windshield Washers

Check the fluid level in the windshield washer reservoir at least monthly during normal use. This reservoir supplies the windshield and rear window washers.

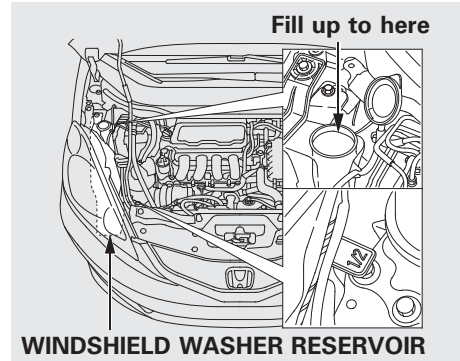

On U.S. models: To check the windshield washer fluid level, open the hood and look for the windshield washer reservoir located behind the right headlight. You will see a “1/2” mark on the reservoir.

On Canadian models: The low washer level indicator comes on when the level is low (see page 65).

Fill the reservoir with a good-quality windshield washer fluid. This increases the cleaning capability and prevents freezing in cold weather.

When you refill the reservoir, clean the edges of the windshield wiper blades with windshield washer fluid on a clean cloth. This will help to condition the blade edges.

NOTICE

Do not use engine antifreeze or a vinegar/water solution in the windshield washer reservoir. Antifreeze can damage your vehicle's paint, while a vinegar/water solution can damage the windshield washer pump. Use only commercially-available windshield washer fluid.

Automatic Transmission Fluid

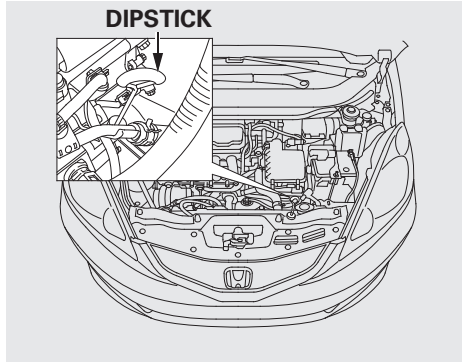

Check the fluid level with the engine at normal operating temperature.

1. Park the vehicle on level ground. Start the engine, let it run until the radiator fan comes on, then shut off the engine. For accurate results, wait about 60 seconds (but no longer than 90 seconds) before doing step 2.

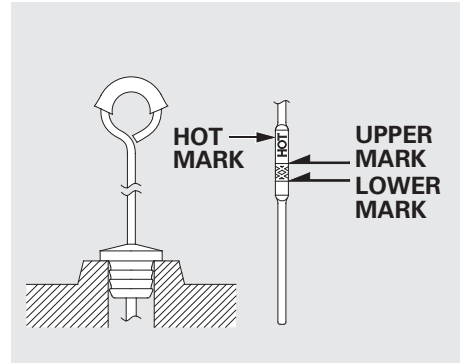

2. Remove the dipstick (yellow loop) from the transmission, and wipe it with a clean cloth.
3. Insert the dipstick all the way into the transmission securely as shown in the illustration.

4. Remove the dipstick, and check the fluid level. It should be between the upper and lower marks.
5. If the level is below the lower mark, add fluid into the dipstick hole to bring it to the level between the upper and lower marks.

Pour the fluid slowly and carefully so you do not spill any. Clean up any spill immediately; it could damage components in the engine compartment.

Always use Honda ATF-Z1 (automatic transmission fluid).

CONTINUED

Transmission Fluid

NOTICE

Use only Honda Genuine ATF-Z1 (automatic transmission fluid). Do not mix with other transmission fluids. Using transmission fluid other than Honda Genuine ATF-Z1 may cause deterioration in transmission operation and durability, and could result in damage to the transmission. Damage resulting from the use of transmission fluid other than Honda Genuine ATF-Z1 is not covered by the Honda new vehicle warranty.

6. Insert the dipstick all the way back into the transmission securely as shown in the illustration.

If you are not sure how to add fluid, contact your dealer.

Manual Transmission Fluid

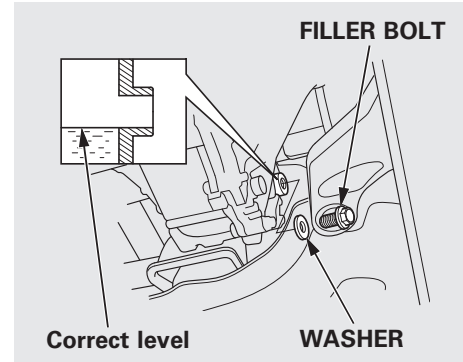

Check the fluid level with the transmission at normal operating temperature and the vehicle on level ground.

Remove the transmission filler bolt, and carefully feel inside the bolt hole with your finger. The fluid level should be up to the edge of the bolt hole. If it is not, add Honda Manual Transmission Fluid (MTF) until it starts to run out of the hole.

Put a new washer on the filler bolt, then reinstall the filler bolt and tighten it securely.

If Honda MTF is not available, you may use an SAE 10W-30 or 10W-40 viscosity motor oil with the API Certification seal that says “FOR GASOLINE ENGINES” as a temporary replacement. However, motor oil does not contain the proper additives, and continued use can cause stiffer shifting. Replace as soon as it is convenient.

If you are not sure how to check and add fluid, contact your dealer.

Brake and Clutch Fluid

Check the brake fluid level in the reservoirs monthly. There are up to two reservoirs, depending on the model. They are:

- Brake fluid reservoir (all models)
- Clutch fluid reservoir (manual transmission models only)

Replace the brake fluid according to the time recommendation in the maintenance minder schedule.

Always use Honda Heavy Duty Brake Fluid DOT 3. If it is not available, you should use only DOT 3 or DOT 4 fluid, from a sealed container, as a temporary replacement.

Using any non-Honda brake fluid can cause corrosion and decrease the life of the system. Have the brake system flushed and refilled with Honda Heavy Duty Brake Fluid DOT 3 as soon as possible.

Brake fluid marked DOT 5 is not compatible with your vehicle's braking system and can cause extensive damage.

Brake Fluid

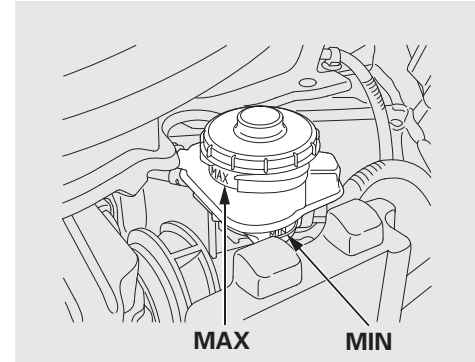

The fluid level should be between the MIN and MAX marks on the side of the reservoir. If the level is at or below the MIN mark, your brake system needs attention. Have the brake system inspected for leaks or worn brake pads/shoes.

Maintenance

CONTINUED

Brake and Clutch Fluid, Lights

Clutch Fluid

Manual Transmission only

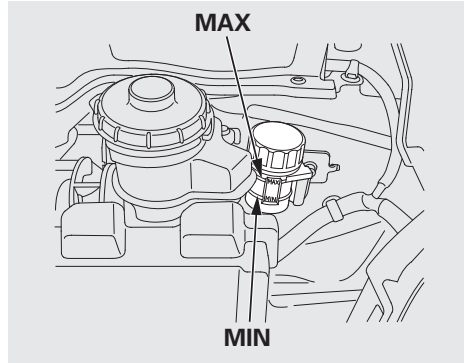

The fluid level should be between the MIN and MAX marks on the side of the reservoir. If it is not, add brake fluid to bring it up to that level. Use the same fluid specified for the brake system.

A low fluid level can indicate a leak in the clutch system. Have this system inspected as soon as possible.

Headlight Aiming

The headlights were properly aimed when your vehicle was new. If you regularly carry heavy items in the cargo area, readjustment may be required. Adjustments should be done by your dealer or another qualified mechanic.

Replacing a Headlight Bulb

Your vehicle has halogen headlight bulbs. When replacing a bulb, handle it by its base, and protect the glass from contact with your skin or hard objects. If you touch the glass, clean it with denatured alcohol and a clean cloth.

NOTICE

Halogen headlight bulbs get very hot when lit. Oil, perspiration, or a scratch on the glass can cause the bulb to overheat and shatter.

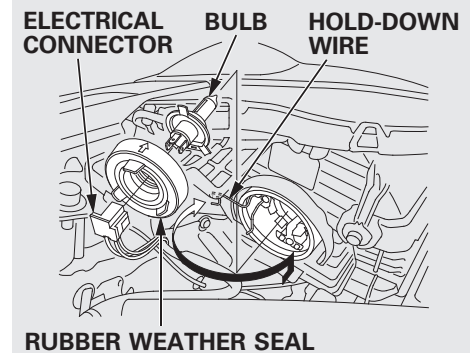

1. Open the hood.
2. Remove the electrical connector from the bulb by pulling the connector straight back.
3. Remove the rubber weather seal by pulling on the tab.

- Unclip the end of the hold-down wire from its slot. Pivot the wire out of the way, then remove the bulb.
- Install the new bulb into the hole, making sure the tabs are in their slots. Pivot the hold-down wire back in place, and clip the end into the slot.

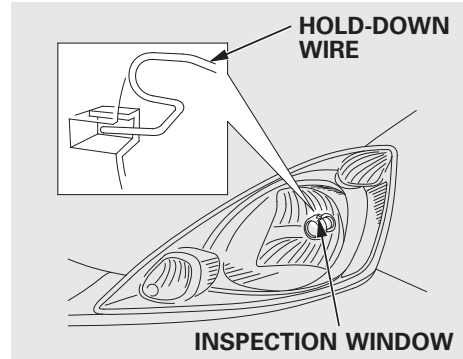

- Make sure that the hold-down wire is installed properly and securely. You can check its installation from the inspection window on the headlight assembly.
- Install the rubber seal over the back of the headlight assembly.
- Push the electrical connector onto the new bulb. Make sure it is connected securely. Turn on the headlights to test the new bulb.

Replacing a Parking Light/Front Side Marker Bulb

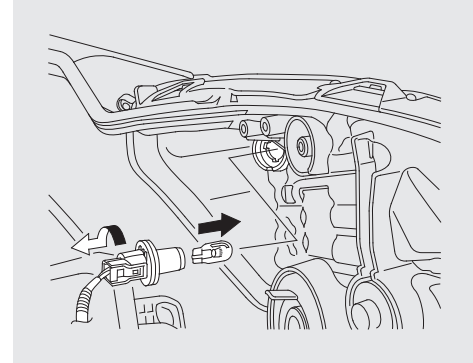

- Open the hood.
- Remove the socket by turning it one-quarter turn counterclockwise.
- Pull the bulb straight out of its socket. Push the new bulb straight into the socket until it bottoms.
- Reinstall the socket into the light assembly by turning it clockwise until it locks.

CONTINUED

Lights

5. Turn on the lights to make sure the new bulb is working.

Replacing a Front Turn Signal Light Bulb

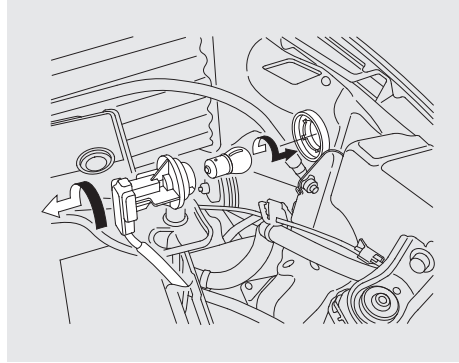

1. Open the hood.
2. Remove the socket by turning it one-quarter turn counterclockwise.
3. Remove the bulb from the socket by pushing the bulb in and turning it counterclockwise until it unlocks.
4. Install the new bulb in the socket. Turn it clockwise to lock it in place.

5. Reinstall the socket into the light assembly by turning it clockwise until it locks.
6. Turn on the lights to make sure the new bulb is working.

Replacing a Fog Light Bulb

On Sport model

The fog lights use halogen bulbs. When replacing a bulb, handle it carefully. See page 262 for more information.

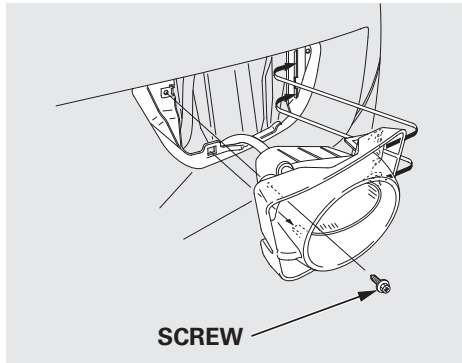

1. Use a Phillips-head screwdriver to remove the screw.
2. To remove the fog light assembly, pull it out of the bumper.

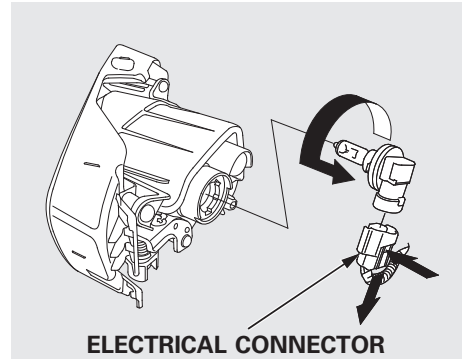

3. Remove the electrical connector from the bulb by squeezing the connector to unlock the tab, then slide the connector off the bulb.
4. Remove the bulb by turning it about one-quarter turn counterclockwise.

5. Insert the new bulb into the hole, and turn it one-quarter turn clockwise to lock it in place.
6. Push the electrical connector back onto the bulb. Make sure it is on all the way.
7. Turn on the fog lights to test the new bulb.
8. Reinstall the fog light assembly, then tighten the screw.

CONTINUED

Lights

Replacing Rear Bulbs



1. Open the tailgate. Place a cloth on the edge of the light assembly cover to prevent scratches. Remove the cover by carefully prying in the notch on its middle edge with a flat-tip screwdriver.

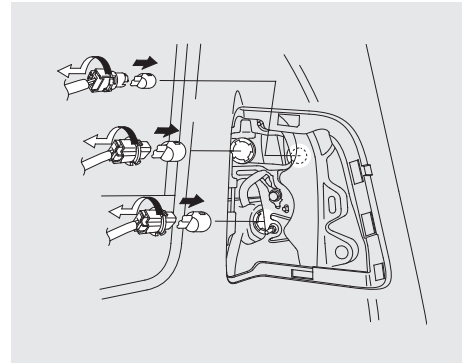

2. Determine which of the three bulbs is burned out: stop/taillight, back-up light, or turn signal light.
3. Remove the socket by turning it one-quarter turn counterclockwise.

4. Remove the burned out bulb from the socket by pulling it straight out of its socket.
5. Install the new bulb in the socket.
6. Turn on the lights to make sure the new bulb is working.
7. Reinstall the socket into the light assembly by turning it clockwise until it locks.
8. Reinstall the light assembly cover.

Cleaning the Seat Belts, Floor Mats

Cleaning the Seat Belts

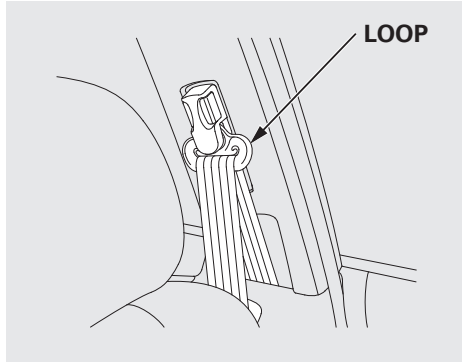

If your seat belts get dirty, use a soft brush with a mixture of mild soap and warm water to clean them. Do not use bleach, dye, or cleaning solvents. Let the belts air-dry before you use the vehicle.

Dirt build-up in the loops of the seat belt anchors can cause the belts to retract slowly. Wipe the insides of the loops with a clean cloth dampened in mild soap and warm water or isopropyl alcohol.

Floor Mats

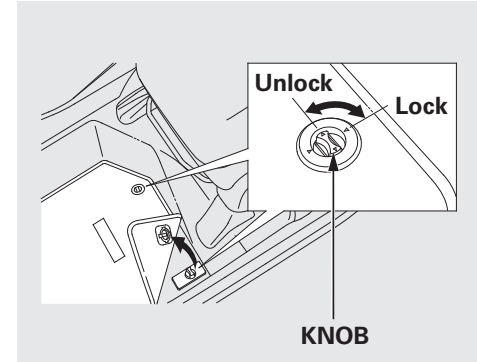

The driver's floor mat that came with your vehicle hooks over the floor mat anchors. To lock each hook, turn the knob clockwise. This keeps the floor mat from sliding forward and possibly interfering with the pedals.

When cleaning or replacing, turn the knob counterclockwise to unhook the floor mat.

CONTINUED

Floor Mats, Audio Antenna, Dust and Pollen Filter

If you remove the driver's floor mat, make sure to re-anchor it when you put it back in your vehicle.

If you use a non-Honda floor mats, make sure they fit properly and that they can be anchored securely. Do not put additional floor mats on top of the anchored mat.

Audio Antenna

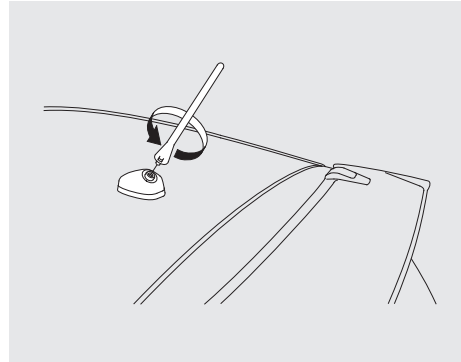

NOTICE

Your vehicle is equipped with an antenna at the rear of the roof. Before using a “drive-through” car wash, remove the antenna by unscrewing it by hand. This prevents the antenna from being damaged by the car wash brushes.

Dust and Pollen Filter

On models with A/C

This filter removes the dust and pollen that is brought in from the outside through the heating and cooling system.

Have your dealer replace the filter when this service is indicated by a maintenance message on the information display. It should be replaced every 15,000 miles (24,000 km) if you drive primarily in urban areas that have high concentrations of soot in the air, or if the flow from the heating and cooling system becomes less than usual.

Wiper Blades

Check the condition of the wiper blades at least every six months. Replace them if you find signs of cracking in the rubber, areas that are getting hard, or if they leave streaks and unwiped areas when used.

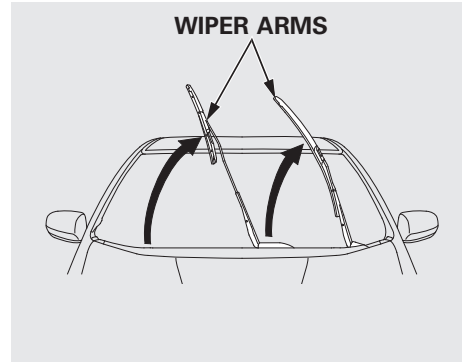

To replace a front wiper blade:

1. Raise the wiper arm off the windshield. Raise the driver's side first, then the passenger's side.

NOTICE

Do not open the hood when the wiper arms are raised, or you will damage the hood and wiper arms.

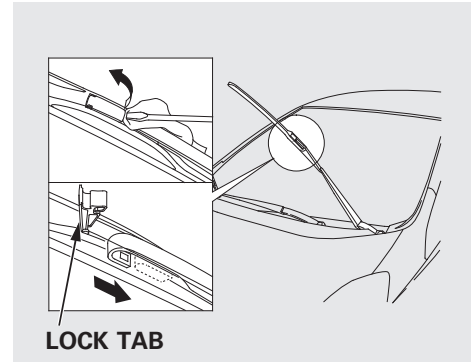

2. Disconnect the blade assembly from the wiper arm:

- Put a cloth on the edge of the lock tab to prevent scratches, then push up on the lock tab carefully with a flat-tip screwdriver.

Wiper Blades

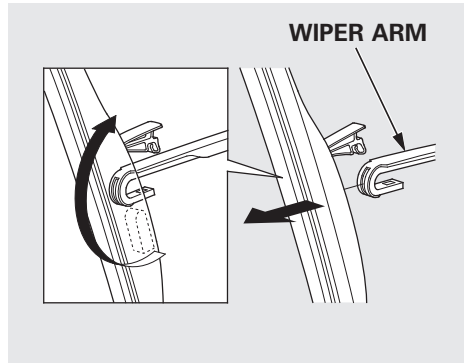

- Pivot the blade assembly toward the wiper arm until it releases from the wiper arm.

When replacing a wiper blade, make sure not to drop the wiper blade or wiper arm down on the windshield.

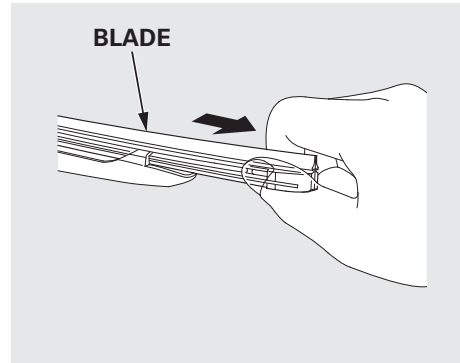

3. Remove the blade from its holder by grabbing the tabbed end of the blade. Pull firmly until the tabs come out of the holder.

4. Examine the new wiper blades. If they have no plastic or metal reinforcement along the back edge, remove the metal reinforcement strips from the old wiper blade, and install them in the slots along the edge of the new blade.

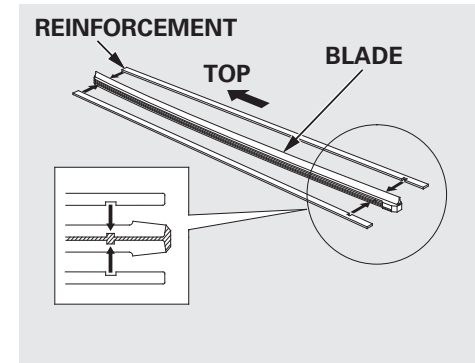

Make sure the two rubber tabs inside the blade fit to each notch of the reinforcement, as shown.

Wiper Blades

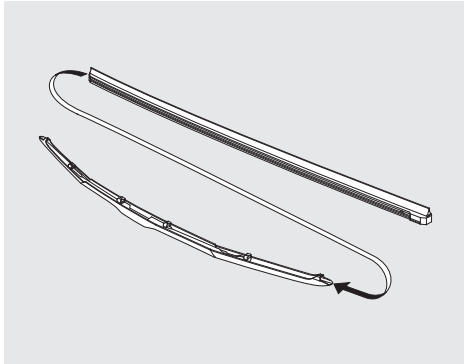

5. Place the top of the wiper blade on the end of the blade assembly, and slide the blade onto the assembly.

Make sure the blade is completely installed.

6. Slide the wiper blade assembly onto the wiper arm. Push down the lock tab. Make sure the wiper blade assembly locks in place.
7. Lower the wiper arm down against the windshield, the passenger's side first, then the driver's side.

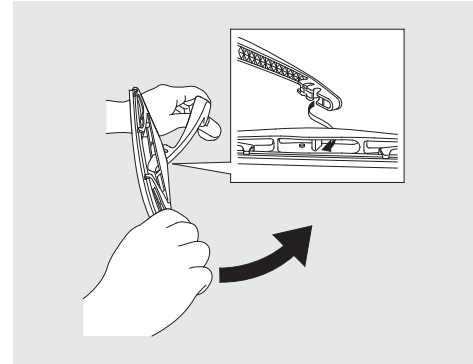

To replace the rear wiper blade:

1. Raise the wiper arm off the rear window.
2. Disconnect the blade assembly from the wiper arm by pivoting the blade assembly upward.

CONTINUED

Wiper Blades

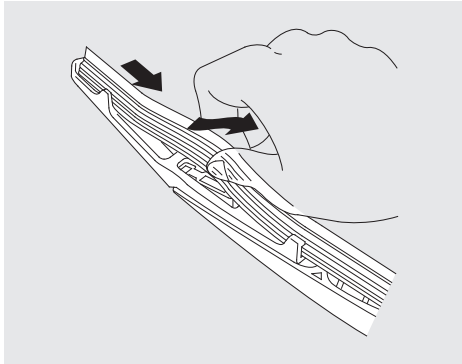

3. Slide the blade out of the holder.

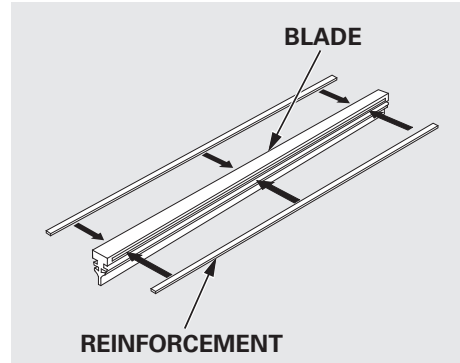

4. Examine the new wiper blades. If they have no plastic or metal reinforcement along the back edge, remove the metal reinforcement strips from the old wiper blade, and install them in the slots along the edge of the new blade.

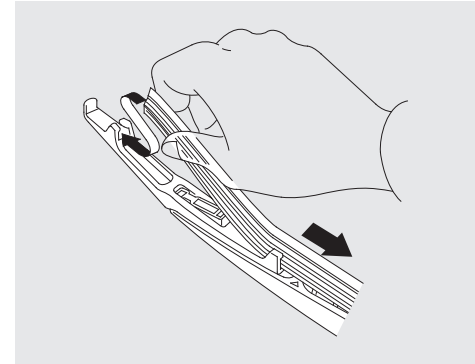

5. Slide the new blade into the holder. Make sure it is engaged in the slot along its full length.

Insert both ends of the blade into the holder. Make sure they are secure.

6. Install the wiper blade assembly onto the wiper arm. Make sure it locks in place.

7. Lower the wiper arm against the windshield.

To safely operate your vehicle, your tires must be the proper type and size, in good condition with adequate tread, and correctly inflated.

The following pages give more detailed information on how to take care of your tires and what to do when they need to be replaced.

⚠ WARNING

Using tires that are excessively worn or improperly inflated can cause a crash in which you can be seriously hurt or killed.

Follow all instructions in this owner's manual regarding tire inflation and maintenance.

Inflation Guidelines

Keeping the tires properly inflated provides the best combination of handling, tread life, and riding comfort.

- Underinflated tires wear unevenly, adversely affect handling and fuel economy, and are more likely to fail from being overheated.
- Overinflated tires can make your vehicle ride more harshly, are more prone to damage from road hazards, and wear unevenly.

The tire pressure monitoring system (TPMS)* warns you when a tire pressure is low. See page 235 for more information.

*: If equipped

Even though your vehicle is equipped with TPMS, we recommend that you visually check your tires every day. If you think a tire might be low, check it immediately with a tire gauge.

Use a gauge to measure the air pressure in each tire at least once a month. Even tires that are in good condition may lose 1 to 2 psi (10 to 20 kPa, 0.1 to 0.2 kgf/cm²) per month. Remember to check the spare tire (if equipped) at the same time.

Check the air pressures when the tires are cold. This means the vehicle has been parked for at least 3 hours, or driven less than 1 mile (1.6 km). Add or release air, if needed, to match the recommended cold tire pressures.

CONTINUED

Tires

If you check air pressures when the tires are hot [driven for several miles (kilometers)], you will see readings 4 to 6 psi (30 to 40 kPa, 0.3 to 0.4 kgf/cm²) higher than the cold readings. This is normal. Do not let air out to match the recommended cold air pressure. The tire will be underinflated.

You should get your own tire pressure gauge and use it whenever you check your tire pressures. This will make it easier for you to tell if a pressure loss is due to a tire problem and not due to a variation between gauges.

While tubeless tires have some ability to self-seal if they are punctured, you should look closely for punctures if a tire starts losing pressure.

Recommended Tire Pressures

The following charts show the recommended cold tire pressures for most normal and high-speed driving conditions.

All models except Sport

Tire Size	Cold Tire Pressure for Normal Driving
175/65R15 84S	Front/Rear: 32 psi (220 kPa, 2.2 kgf/cm ²)

Sport model

Tire Size	Cold Tire Pressure for Normal Driving
185/55R16 83H	Front/Rear: 33 psi (230 kPa, 2.3 kgf/cm ²)

If equipped

The compact spare tire pressure is:
60 psi (420 kPa, 4.2 kgf/cm²)

For convenience, the recommended tire sizes and cold tire pressures are on a label on the driver's doorjamb.

For additional information about your tires, see page 323.

Tire Inspection

Every time you check inflation, you should also examine the tires for damage, foreign objects, and wear.

You should look for:

- Bumps or bulges in the tread or side of the tire. Replace the tire if you find either of these conditions.
- Cuts, splits, or cracks in the side of the tire. Replace the tire if you can see fabric or cord.
- Excessive tread wear.

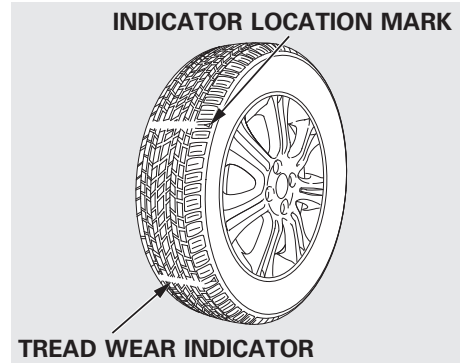

Your tires have wear indicators molded into the tread. When the tread wears down, you will see a 1/2 inch (12.7 mm) wide band across the tread. This shows there is less than 1/16 inch (1.6 mm) of tread left on the tire.

A tire this worn gives very little traction on wet roads. You should replace the tire if you can see three or more tread wear indicators.

Tire Service Life

The service life of your tires is dependent on many factors, including, but not limited to, driving habits, road conditions, vehicle loading, inflation pressure, maintenance history, speed, and environmental conditions (even when the tires are not in use).

In addition to your regular inspections and inflation pressure maintenance, it is recommended that you have annual inspections performed once the tires reach five years old. It is also recommended that all tires, including the spare, be removed from service after 10 years from the date of manufacture, regardless of their condition or state of wear.

The last four digits of the TIN (tire identification number) are found on the sidewall of the tire and indicate the date of manufacture (See **Tire Labeling** on page 323).

CONTINUED

Tires

Tire Maintenance

In addition to proper inflation, correct wheel alignment helps to decrease tire wear. If you find a tire is worn unevenly, have your dealer check the wheel alignment.

Have your dealer check the tires if you feel a consistent vibration while driving. A tire should always be rebalanced if it is removed from the wheel. When you have new tires installed, make sure they are balanced. This increases riding comfort and tire life. For best results, have the installer perform a dynamic balance.

NOTICE

On vehicles with aluminum wheels, improper wheel weights can damage your vehicle's aluminum wheels. Use only Honda wheel weights for balancing.

Tire Rotation

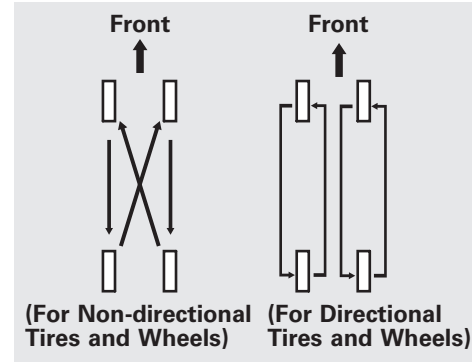

To help increase tire life and distribute wear more evenly, rotate the tires according to the maintenance messages displayed on the information display. Move the tires to the positions shown in the illustration each time they are rotated. If you purchase directional tires, rotate only front-to-back.

When the tires are rotated, make sure the air pressures are checked.

Replacing Tires and Wheels

Replace your tires with radial tires of the same size, load range, speed rating, and maximum cold tire pressure rating (as shown on the tire's sidewall).

Mixing radial and bias-ply tires on your vehicle can reduce braking ability, traction, and steering accuracy. Using tires of a different size or construction can cause the ABS and vehicle stability assist system (VSA)* to work inconsistently.

The ABS and VSA system* work by comparing the speed of the wheels. When replacing tires, use the same size originally supplied with the vehicle. Tire size and construction can affect wheel speed and may cause the system to activate.

*: If equipped

It is best to replace all four tires at the same time. If that is not possible or necessary, replace the two front tires or two rear tires as a pair. Replacing just one tire can seriously affect your vehicle's handling.

If you ever replace a wheel, make sure that the wheel's specifications match those of the original wheels.

Also be sure you use only TPMS specific wheels (if equipped). If you do not, the tire pressure monitoring system will not work.

Replacement wheels are available at your dealer.

⚠ WARNING

Installing improper tires on your vehicle can affect handling and stability. This can cause a crash in which you can be seriously hurt or killed.

Always use the size and type of tires recommended in this owner's manual.

Wheel and Tire Specifications

Wheels:

All models except Sport

15 x 5 1/2J

Sport model

16 x 6J

Tires:

All models except Sport

175/65R15 84S

Sport model

185/55R16 83H

See page 321 for DOT tire quality grading information, and page 323 for tire size and labeling information.

CONTINUED

Tires

Winter Driving

Tires marked “M + S” or “All Season” on the sidewall have an all-weather tread design suitable for most winter driving conditions.

For the best performance in snowy or icy conditions, you should install snow tires or tire chains. They may be required by local laws under certain conditions.

Snow Tires

If you mount snow tires on your vehicle, make sure they are radial tires of the same size and load range as the original tires. Mount snow tires on all four wheels. The traction provided by snow tires on dry roads may be lower than your original tires. Check with the tire dealer for maximum speed recommendations.

Tire Chains

Mount tire chains on your tires when required by driving conditions or local laws. Install them only on the front tires.

Because your vehicle has limited tire clearance, Honda strongly recommends using the chains listed below, made by Security Chain Company (SCC).

All models except Sport
SC1026

Sport model
SC1030

When installing cables, follow the manufacturer's instructions, and mount them as tight as you can. Make sure they are not contacting the brake lines or suspension. Drive slowly with them installed. If you hear them coming into contact with the body or chassis, stop and investigate. Remove them as soon as you begin driving on cleared roads.

NOTICE

Traction devices that are the wrong size or improperly installed can damage your vehicle's brake lines, suspension, body, and wheels. Stop driving if they are hitting any part of the vehicle.

WARNING

Using the wrong chains, or not properly installing chains, can damage the brake lines and cause a crash in which you can be seriously injured or killed.

Follow all instructions in this owner's manual regarding the selection and use of tire chains.

Wheels

Clean the wheels as you would the rest of the exterior. Wash them with the same solution, and rinse them thoroughly.

If equipped

Aluminum alloy wheels have a protective clear-coat that keeps the aluminum from corroding and tarnishing. Cleaning the wheels with harsh chemicals (including some commercial wheel cleaners) or a stiff brush can damage the clear-coat. To clean the wheels, use a mild detergent and a soft brush or sponge.

Checking the Battery

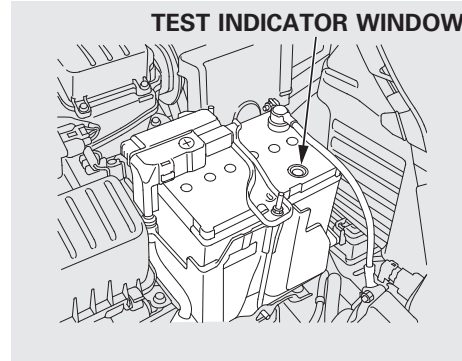

Check the condition of the battery monthly by looking at the test indicator window. The label on the battery explains the test indicator's colors.

The location of the test indicator window varies between manufacturers.

Check the terminals for corrosion (a white or yellowish powder). To remove it, cover the terminals with a solution of baking soda and water. It will bubble up and turn brown. When this stops, wash it off with plain water. Dry off the battery with a cloth or paper towel. Coat the terminals with grease to help prevent future corrosion.

If additional battery maintenance is needed, see your dealer or a qualified technician.

CONTINUED

Checking the Battery

WARNING: Battery posts, terminals, and related accessories contain lead and lead compounds. **Wash your hands after handling.**

If you need to connect the battery to a charger, disconnect both cables to prevent damaging your vehicle's electrical system. Always disconnect the negative (–) cable first, and reconnect it last.

On vehicles without navigation system
If your vehicle's battery is disconnected, or goes dead, the time setting is lost. To reset the time, see page 192.

If your vehicle's battery is disconnected, or goes dead, the audio system may disable itself. The next time you turn on the radio, you will see “ENTER CODE” in the frequency display. Use the preset buttons to enter the code (see page 191).

WARNING

The battery gives off explosive hydrogen gas during normal operation.

A spark or flame can cause the battery to explode with enough force to kill or seriously hurt you.

Wear protective clothing and a face shield, or have a skilled technician do the battery maintenance.

On vehicles with navigation system
The navigation system will also disable itself. The next time you turn on the ignition switch, the system will require you to enter “ENTER CODE” before it can be used. Refer to the navigation system manual.

If you need to park your vehicle for an extended period (more than 1 month), there are several things you should do to prepare it for storage. Proper preparation helps prevent deterioration and makes it easier to get your vehicle back on the road. If possible, store your vehicle indoors.

- Fill the fuel tank.
 - Wash and dry the exterior completely.
 - Clean the interior. Make sure the carpeting, floor mats, etc., are completely dry.
 - Leave the parking brake off. Put the transmission in reverse (manual) or Park (automatic).
 - Block the rear wheels.
- If the vehicle is to be stored for a longer period, it should be supported on jackstands so the tires are off the ground.
 - Leave one window open slightly (if the vehicle is being stored indoors).
 - Disconnect the battery.
 - Support the front and rear wiper blade arms with a folded towel or rag so they do not touch the windshield.
 - To minimize sticking, apply a silicone spray lubricant to all door and tailgate seals. Also, apply a vehicle body wax to the painted surfaces that mate with the door and tailgate seals.
- Cover the vehicle with a “breathable” cover, one made from a porous material such as cotton. Non-porous materials, such as plastic sheeting, trap moisture, which can damage the paint.
 - If possible, periodically run the engine until it reaches full operating temperature (the cooling fans cycle on and off twice). Preferably, do this once a month.

Taking Care of the Unexpected

This section covers the more common problems that motorists experience with their vehicles. It gives you information about how to safely evaluate the problem and what to do to correct it. If the problem has stranded you on the side of the road, you may be able to get going again. If not, you will also find instructions on getting your vehicle towed.

Compact Spare Tire	284
Changing a Flat Tire	285
Temporarily Repairing a Flat Tire	291
If the Engine Won't Start.....	297
Jump Starting.....	299
If the Engine Overheats	301
Low Oil Pressure Indicator	303
Charging System Indicator	303
Malfunction Indicator Lamp.....	304
Brake System Indicator.....	305
Fuses	306
Fuse Locations.....	309
Emergency Towing.....	311
If Your Vehicle Gets Stuck	312

Compact Spare Tire

Except all Canadian models with automatic transmission

Use the compact spare tire as a temporary replacement only. Get your regular tire repaired or replaced, and put it back on your vehicle as soon as you can.

Check the inflation pressure of the compact spare tire every time you check the other tires. It should be inflated to:
60 psi (420 kPa, 4.2 kgf/cm²)

Follow these precautions:

- Never exceed 50 mph (80 km/h).
- This tire gives a harsher ride and less traction on some road surfaces. Use greater caution while driving.
- Do not mount tire chains on the compact spare tire.
- Do not use your compact spare tire on another vehicle unless it is the same make and model.
- On vehicles with the TPMS system, the low tire pressure indicator comes on and stays on after you replace the flat tire with the compact spare tire. After several miles (kilometers) driving with the compact spare tire, the TPMS indicator comes on and the low tire pressure indicator goes off.

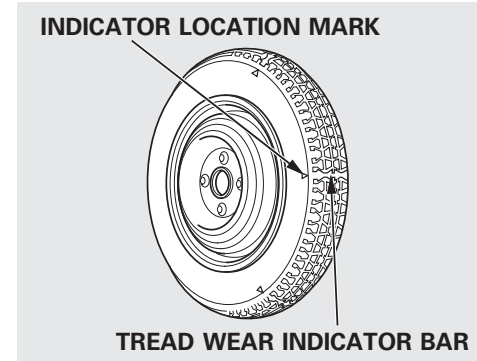

Replace the tire when you can see the tread wear indicator bars. The replacement should be the same size and design tire, mounted on the same wheel. The spare tire is not designed to be mounted on a regular wheel, and the spare wheel is not designed for mounting a regular tire.

Changing a Flat Tire

Except all Canadian models with automatic transmission

If you have a flat tire while driving, stop in a safe place to change it. Drive slowly along the shoulder until you get to an exit or an area to stop that is far away from the traffic lanes.

⚠ WARNING

The vehicle can easily roll off the jack, seriously injuring anyone underneath.

Follow the directions for changing a tire exactly, and never get under the vehicle when it is supported only by the jack.

1. Park the vehicle on firm, level, and non-slippery ground. Put the transmission in Park (automatic) or reverse (manual). Apply the parking brake.
2. Turn on the hazard warning lights, and turn the ignition switch to the LOCK (0) position. Have all passengers get out of the vehicle while you change the tire.
3. Lift the rear center head restraint.

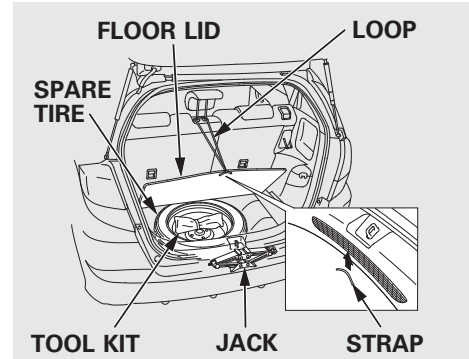

4. Open the tailgate. Raise the cargo area floor lid by lifting it up with the back of the strap. To keep the floor lid open, hook the looped side of the strap to the legs of the rear center head restraint.
5. Take the tool kit out of the spare tire.

CONTINUED

Changing a Flat Tire

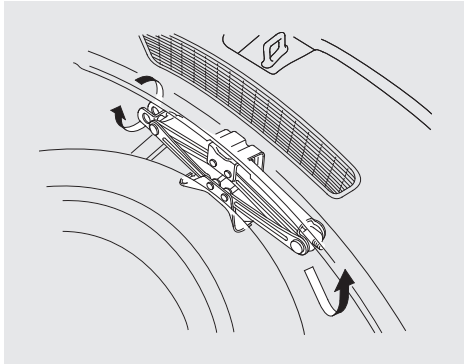

6. Take the jack out of the cargo area.
Turn the jack's end bracket counterclockwise to loosen it, then remove the jack by lifting it straight up.
7. Unscrew the wing bolt and take the spare tire out of its well.

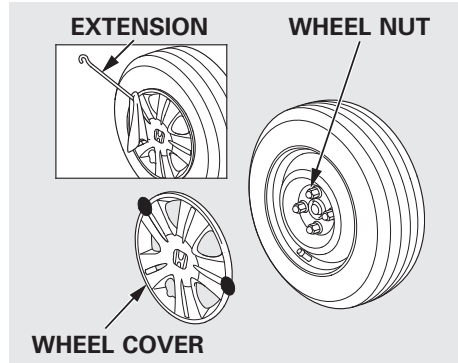

8. On all models except Sport and Canadian LX model with manual transmission, remove the wheel cover by carefully prying under its edge with the flat tip of the extension.



9. Loosen each wheel nut 1/2 turn with the wheel nut wrench.

Changing a Flat Tire

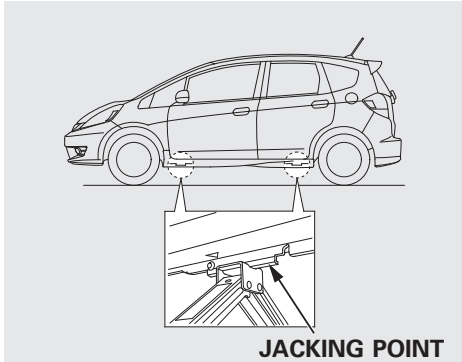

10. Place the jack under the jacking point nearest the tire you need to change. It is pointed to by a \triangle mark molded into the underside of the body (Sport model). Turn the end bracket clockwise until the top of the jack contacts the jacking point. Make sure the jacking point tab is resting in the jack notch.

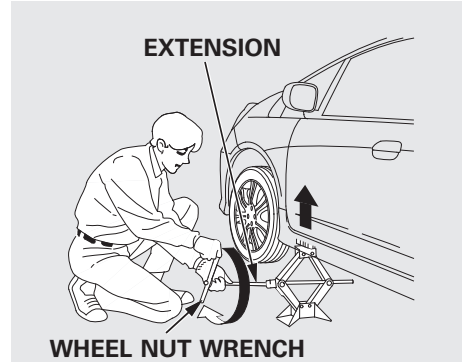

11. Use the extension and the wheel nut wrench as shown to raise the vehicle until the flat tire is off the ground.
12. Remove the wheel nuts, then remove the flat tire. Handle the wheel nuts carefully; they may be hot from driving. Place the flat tire on the ground with the outside surface facing up.

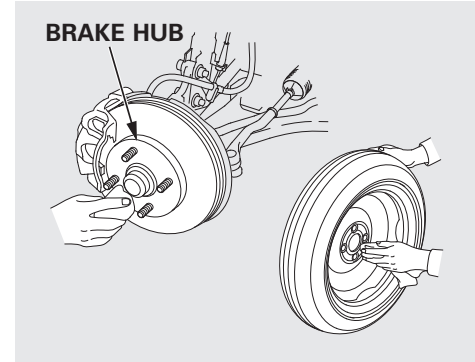

13. Before mounting the spare tire, wipe any dirt off the mounting surface of the wheel and hub with a clean cloth. Wipe the hub carefully; it may be hot from driving.

CONTINUED

Changing a Flat Tire

- Put on the spare tire. Put the wheel nuts back on finger-tight, then tighten them in a crisscross pattern with the wheel nut wrench until the wheel is firmly against the hub. Do not try to tighten the wheel nuts fully.
- Lower the vehicle to the ground, and remove the jack.

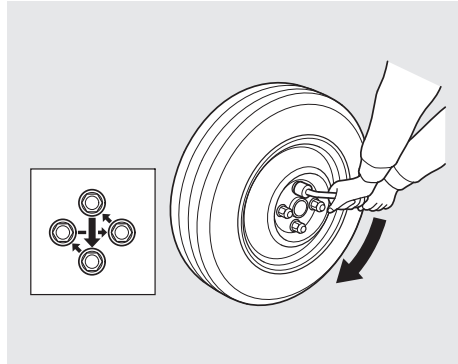

- Tighten the wheel nuts securely in the same crisscross pattern. Have the wheel nut torque checked at the nearest automotive service facility.
Tighten the wheel nuts to:
80 lbf·ft (108 N·m, 11 kgf·m)
- On Sport model and Canadian LX model with manual transmission:*
Remove the center cap before storing the flat tire.

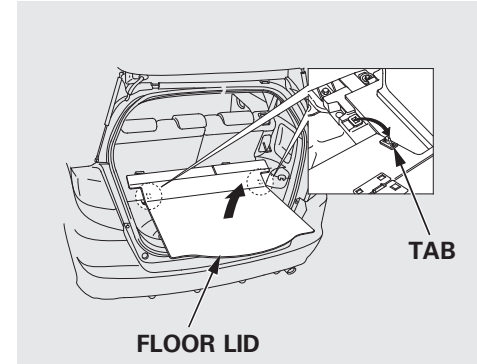

- Remove the strap loop from the legs of the head restraint and lower the cargo area floor lid.
- Pull the floor lid toward you and remove the tabs.
- Pull the floor lid out.

Changing a Flat Tire

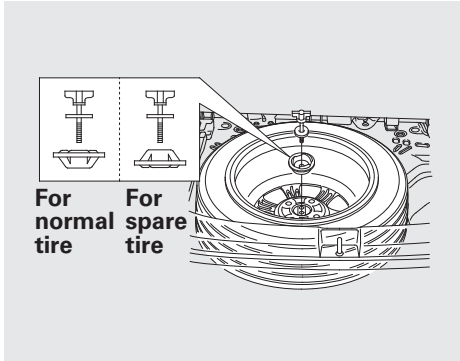

21. Place the flat tire face down in the spare tire well.
22. Secure the flat tire by screwing the wing bolt back into its hole.

23. Store the jack. Place the tool kit in the center of the flat tire.

⚠ WARNING

Loose items can fly around the interior in a crash and could seriously injure the occupants.

Store the wheel, jack, and tools securely before driving.

24. Place the floor lid in the cargo area.
25. Store the wheel cover or center cap in the cargo area. Make sure it will not get scratched or damaged.
26. Close the tailgate.
27. *On U.S. models*
Your vehicle's original tire has a tire pressure monitoring system sensor. To replace a tire, refer to **Changing a Tire with TPMS** (see page 237).

CONTINUED

Changing a Flat Tire

Installing a wheel cover

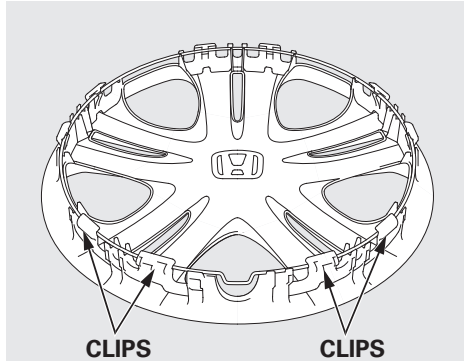

All models except Sport and Canadian LX model with manual transmission

1. Make sure the wire support ring is hooked into the clips around the edge of the wheel cover.

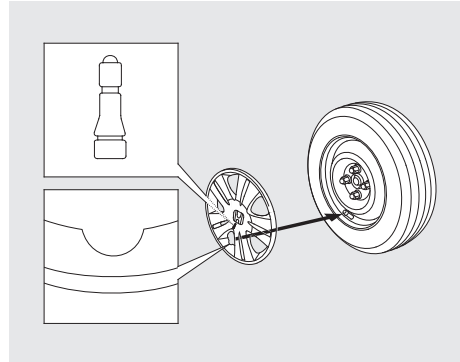

2. Align the valve mark on the wheel cover to the tire valve on the wheel, then install the wheel cover.

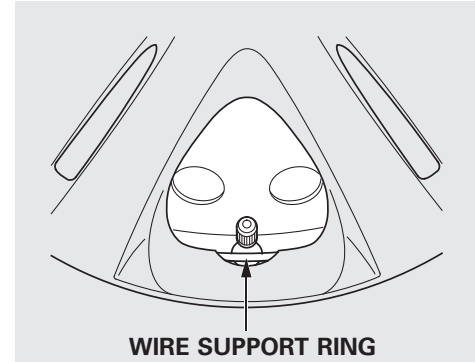

3. Make sure the wire support ring is on the outer side of the tire valve as shown.

Temporarily Repairing a Flat Tire

How to Use the Tire Repair Kit

All Canadian models with automatic transmission

To reduce weight, your vehicle is equipped with a tire repair kit instead of a spare tire. This kit will allow you to temporarily repair a flat tire under the following conditions:

- Only one tire is flat.
- The puncture is smaller than 3/16ths of an inch (4 mm).
- The puncture is located within the tread.
- The wheel rim is not damaged.
- The tire bead is seated.

When making a temporary repair, carefully follow all instructions in this owner's manual and in the instructions that came with the kit.

If you have a flat tire while driving, park the vehicle on a level surface in a safe place, put the transmission in Park (P), set the parking brake, and turn the hazard lights on. Thoroughly examine the tire for a puncture or other damage.

If a puncture is wider than 3/16ths of an inch (4 mm), or is located in the tire sidewall, do not attempt to repair the tire. Have your vehicle towed to a Honda service center. In Canada or the continental U.S.A. simply call 1-800-465-PLUS (7587) for Honda Plus Roadside Assistance.

If the damage is smaller than 3/16ths of an inch (4 mm) and within the tire tread, proceed with the following instructions.

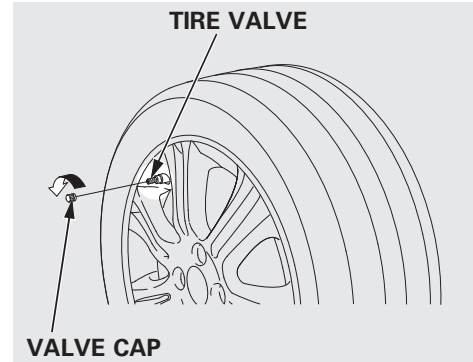

1. Park vehicle on a level surface in a safe place. Set shifter lever into PARK and engage the parking brake. Turn hazard light on. Remove valve cap from tire valve.

CONTINUED

Temporarily Repairing a Flat Tire

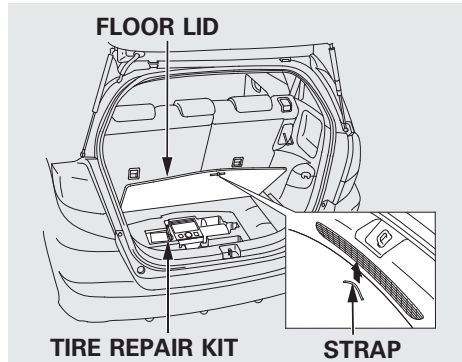

2. Open the tailgate.
3. Raise the cargo area floor lid by lifting it up with the back of the strap. Remove the tire repair kit.

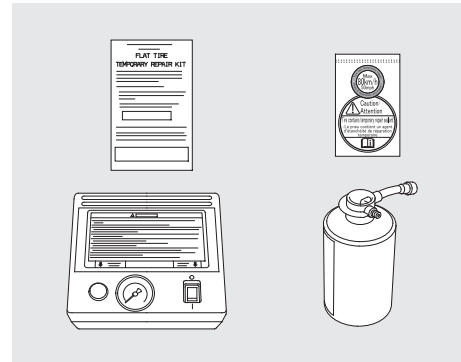

Your tire repair kit contains:

- An air pump with a power cord and an air hose attached.
- A bottle of sealant with a filler hose attached.
- Two labels, one for the tire wheel and one for the instrument panel.
- An instruction sheet.

- An empty recovery bottle. A tire repair professional will use this to collect the injected sealant from the tire during the permanent repair.

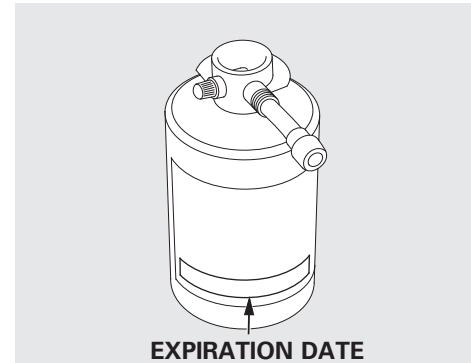

4. Remove the sealant bottle and check the expiration date on the label. If the date has expired, do not continue. Have your vehicle towed to the nearest Honda service center. In Canada or the continental U.S.A. simply call 1-800-465-PLUS (7587) for Honda Plus Roadside Assistance.

Temporarily Repairing a Flat Tire

If the date has not expired, shake the bottle thoroughly and proceed to step 5.

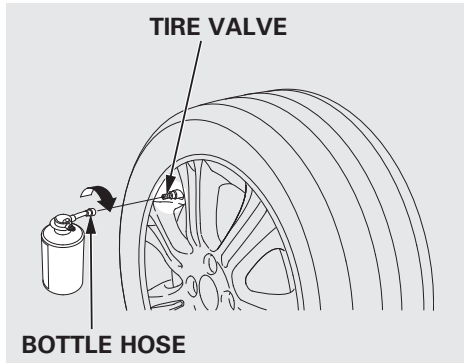

5. Screw the sealant filler hose onto the tire valve. Make sure the bottle remains upright to ensure all of the sealant flows into the tire.

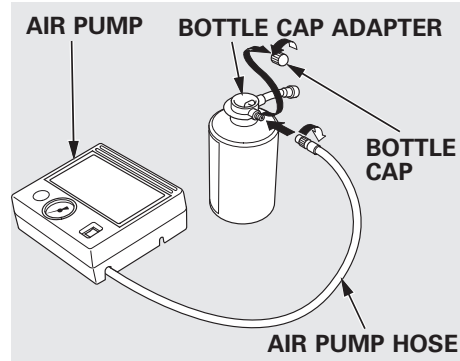

6. Unscrew the bottle cap from the bottle adapter.
7. Remove the air pump from the repair kit, then screw the air pump hose onto the bottle adapter tightly.

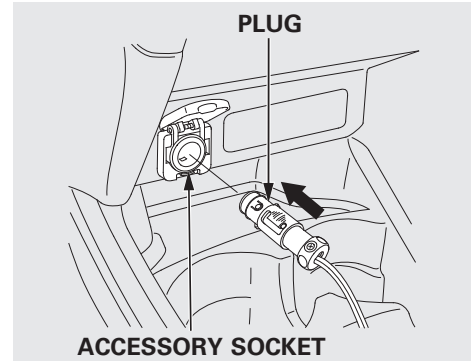

8. Route the power cord into the vehicle, and insert the plug into the accessory power socket.

Pay attention not to have the power cord pinched by the door.

9. Turn the ignition switch to the ACCESSORY (I) position.

CONTINUED

Temporarily Repairing a Flat Tire

In freezing temperatures, turn the engine on and leave it running while the flat tire is being serviced. Prolonged exposure to the cold may cause the vehicle's battery to weaken. Under cold conditions, safely start the vehicle's engine and keep the engine running at idle when operating the air pump.

⚠ WARNING

Running the engine with the vehicle in an enclosed or even partly enclosed area can cause a rapid build-up of toxic carbon monoxide. Breathing this colorless, odorless gas can cause unconsciousness and even death. Only run the engine to power the air pump with the vehicle outdoors.

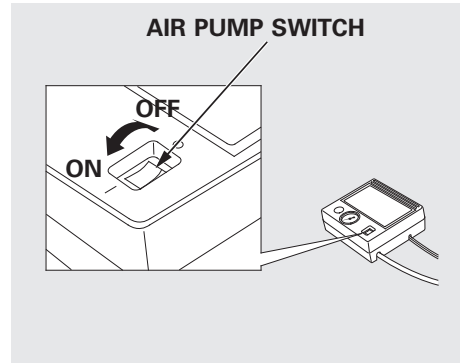

10. Turn the air pump on to inflate the tire. Do not run the air pump for more than 15 minutes or it may overheat. The air pressure gauge will show about 40 to 60 psi (275 to 415 kPa) for the first few minutes while the sealant is pumped into the tire, and then the pressure will go down to about 10 to 20 psi (70 to 140 kPa).

11. Inflate the tire to 33 psi (230 kPa), then turn the air pump switch OFF for an accurate pressure reading. If the pressure fails to reach 33 psi (230 kPa) within 15 minutes, do not continue, and have the vehicle towed. In Canada or the continental U.S.A. simply call 1-800-465-PLUS (7587) for Honda Plus Roadside Assistance.
12. Turn the ignition switch to the LOCK (0) position.
13. Remove the sealant bottle hose from the tire valve, then reinstall the tire valve cap.

Temporarily Repairing a Flat Tire

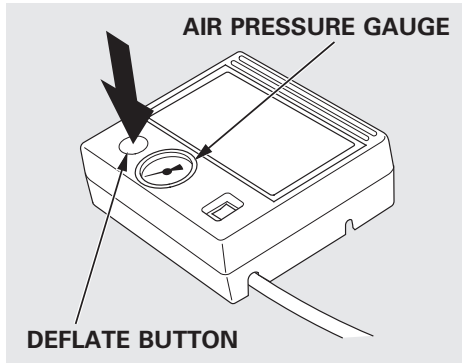

14. Push the deflate button on the air pump until the air pressure gauge shows 0 psi.

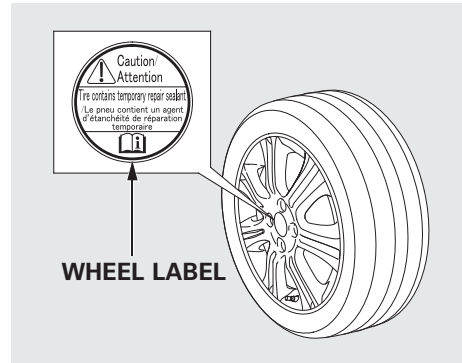

15. Remove the wheel label from the repair kit, wipe any dirt off the wheel with a clean cloth, and attach the label to the center of the wheel.
The label may adhere poorly when cold. Clean the surface and securely attach the label.

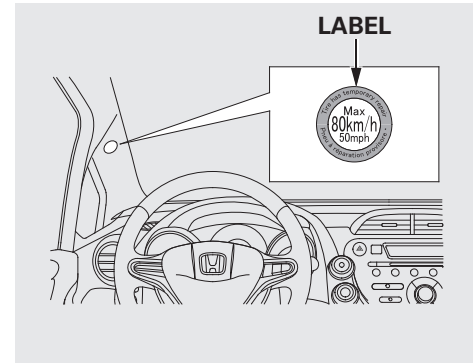

16. Remove the front pillar label from the repair kit and place it as shown above.
17. Remove the power plug from the accessory power socket.
18. Return all items except the air pump to the repair kit, and store the kit in the cargo floor box. Keep the air pump handy as you may need it soon.

CONTINUED

Temporarily Repairing a Flat Tire

19. Drive carefully within the speed of 50 mph (80 km/h) for 5 minutes.

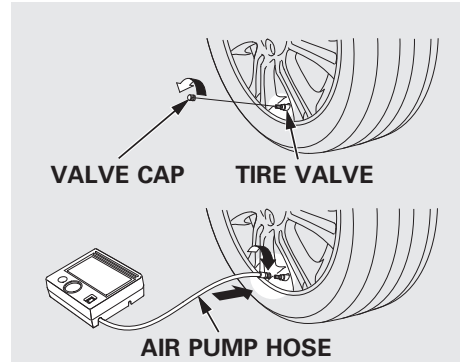

20. Stop safely and check the pressure in the tire. Remove the tire valve cap, screw the air pump hose onto the tire valve, and check the air gauge. (You do not need to attach the power cord or turn the air pump switch on.)

If pressure is less than 19 psi (130 kPa), do not drive the vehicle further or attempt to re-inflate the tire. Call or wait for help. If pressure is lower than 33 psi (230 kPa) and higher than 19 psi (130 kPa), use air pump to bring tire pressure to 33 psi (230 kPa).

21. Then, drive carefully within the speed of 50 mph (80 km/h) for 5 minutes more.
22. Stop safely and check the pressure in the tire.

Temporarily Repairing a Flat Tire, If the Engine Won't Start

If the pressure is lower than 32 psi (220 kPa) and higher than 19 psi (130 kPa), use the air pump to bring air to the desired level as described in step 11. Then drive to the nearest service station at no more than 50 mph (80 km/h).

If the pressure is below 19 psi, do not continue. Have the vehicle towed (see page 311).

In any case, be sure to have the damaged tire permanently repaired as soon as possible.

Remember to return the tire sealant bottle to your Honda service center for proper disposal.

If the Engine Won't Start

Diagnosing why the engine won't start falls into two areas, depending on what you hear when you turn the ignition switch to the START (III) position:

- You hear nothing, or almost nothing. The engine's starter motor does not operate at all, or operates very slowly.
- You can hear the starter motor operating normally, or the starter motor sounds like it is spinning faster than normal, but the engine does not start up and run.

Nothing Happens or the Starter Motor Operates Very Slowly

When you turn the ignition switch to the START (III) position, you do not hear the normal noise of the engine trying to start. You may hear a clicking sound, a series of clicks, or nothing at all.

Check these things:

- Check the transmission interlock. If you have a manual transmission, the clutch pedal must be pushed all the way to the floor or the starter will not operate. With an automatic transmission, it must be in Park or neutral.
- Turn the ignition switch to the ON (II) position. Turn on the headlights, and check their brightness. If the headlights are very dim or do not come on at all, the battery is discharged. See **Jump Starting** on page 299.

CONTINUED

If the Engine Won't Start

- Turn the ignition switch to the START (III) position. If the headlights do not dim, check the condition of the fuses. If the fuses are OK, there is probably something wrong with the electrical circuit for the ignition switch or starter motor. You will need a qualified technician to determine the problem. See **Emergency Towing** on page 311.

If the headlights dim noticeably or go out when you try to start the engine, either the battery is discharged or the connections are corroded. Check the condition of the battery and terminal connections (see page 279). You can then try jump starting the vehicle from a booster battery (see page 299).

The Starter Operates Normally

In this case, the starter motor's speed sounds normal, or even faster than normal, when you turn the ignition switch to the START (III) position, but the engine does not run.

- Are you using a properly coded key? An improperly coded key will cause the immobilizer system indicator in the instrument panel to blink rapidly (see page 79).
 - Are you using the proper starting procedure? Refer to **Starting the Engine** on page 216.
- Do you have fuel? Check the fuel gauge; the low fuel indicator may not be working.
 - There may be an electrical problem, such as no power to the fuel pump. Check all the fuses (see page 306).

If you find nothing wrong, you will need a qualified technician to find the problem. See **Emergency Towing** on page 311.

Jump Starting

Although this seems like a simple procedure, you should take several precautions.

WARNING

A battery can explode if you do not follow the correct procedure, seriously injuring anyone nearby.

Keep all sparks, open flames, and smoking materials away from the battery.

You cannot start your vehicle with an automatic transmission by pushing or pulling it.

To Jump Start Your Vehicle:

1. Open the hood, and check the physical condition of the battery. In very cold weather, check the condition of the electrolyte. If it seems slushy or frozen, do not try jump starting until it thaws.

NOTICE

If a battery sits in extreme cold, the electrolyte inside can freeze. Attempting to jump start with a frozen battery can cause it to rupture.

2. Turn off all the electrical accessories: heater, A/C (if equipped), audio system, lights, etc. Put the transmission in neutral (manual) or Park (automatic), and set the parking brake.

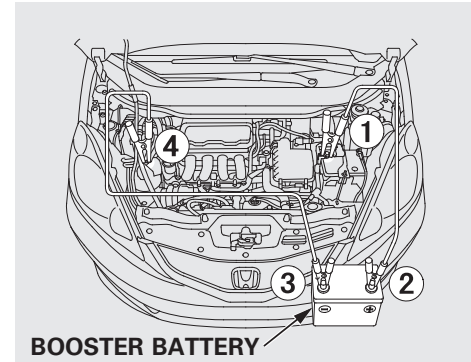

The numbers in the illustration show you the order to connect the jumper cables.

CONTINUED

Jump Starting

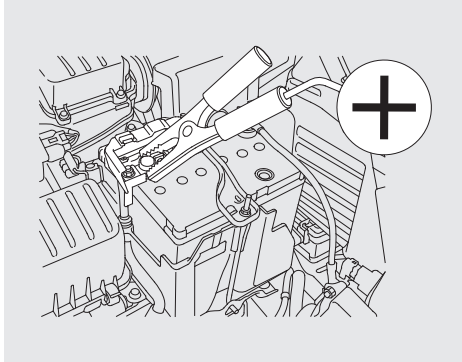

3. Remove the cover from the under-hood fuse box (see page 306). Connect one jumper cable to the positive (+) terminal on your battery. Connect the other end to the positive (+) terminal on the booster battery.

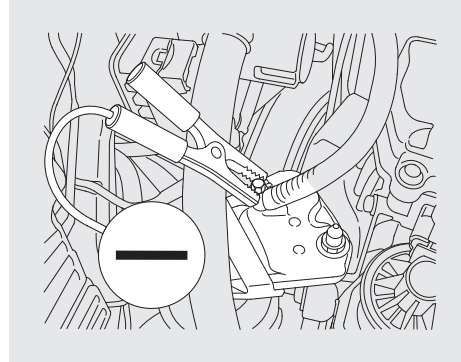

4. Connect the second jumper cable to the negative (-) terminal on the booster battery. Connect the other end to the ground strap as shown. Do not connect this jumper cable to any other part of the engine.

5. If the booster battery is in another vehicle, have an assistant start that vehicle and run it at a fast idle.
6. Start your vehicle. If the starter motor still operates slowly, check that the jumper cables have good metal-to-metal contact.
7. Once your vehicle is running, disconnect the negative cable from your vehicle, then from the booster battery. Disconnect the positive cable from your vehicle, then from the booster battery.

Keep the ends of the jumper cables away from each other and any metal on the vehicle until everything is disconnected. Otherwise, you may cause an electrical short.

If the Engine Overheats

The high temperature indicator should be off under most conditions. If the engine coolant temperature gets higher than normal, the indicator will blink. If it stays on, you should determine the reason (hot day, driving up a steep hill, etc.).

If the vehicle overheats, you should take immediate action. The only indication may be the high temperature indicator blinking or remaining on. Or you may see steam or spray coming from under the hood.

NOTICE

Driving with the high temperature indicator on can cause serious damage to your engine.

⚠ WARNING

Steam and spray from an overheated engine can seriously scald you.

Do not open the hood if steam is coming out.

1. Safely pull to the side of the road. Put the transmission in neutral (manual) or Park (automatic), and set the parking brake. Turn off all accessories, and turn on the hazard warning lights.
2. If you see steam and/or spray coming from under the hood, turn off the engine. Wait until you see no more signs of steam or spray, then open the hood.
3. If you do not see steam or spray, leave the engine running, and check the high temperature indicator. If the high heat is due to overloading, the engine should start to cool down almost immediately. If it does, wait until the high temperature indicator goes off, then continue driving.
4. If the high temperature indicator stays on, turn off the engine.

CONTINUED

If the Engine Overheats

5. Look for any obvious coolant leaks, such as a split radiator hose. Everything is still extremely hot, so use caution. If you find a leak, it must be repaired before you continue driving (see **Emergency Towing** on page 311).
6. If you don't find an obvious leak, check the coolant level in the radiator reserve tank. Add coolant if the level is below the MIN mark.
7. If there was no coolant in the reserve tank, you may need to add coolant to the radiator. Let the engine cool down until the high temperature indicator goes off before checking the radiator.

WARNING

Removing the radiator cap while the engine is hot can cause the coolant to spray out, seriously scalding you.

Always let the engine and radiator cool down before removing the radiator cap.

8. Using gloves or a large heavy cloth, turn the radiator cap counterclockwise, without pushing down, to the first stop. After the pressure releases, push down on the cap, and turn it until it comes off.
9. Start the engine, and set the temperature control dial to maximum heat. Add coolant to the radiator up to the base of the filler neck. If you do not have the proper coolant mixture available, you can add plain water. Remember to have the cooling system drained and refilled with the proper mixture as soon as you can.
10. Put the radiator cap back on tightly. Run the engine, and check the high temperature indicator. If it begins to blink or comes on again, the engine needs repair (see **Emergency Towing** on page 311).
11. If the temperature stays normal, check the coolant level in the radiator reserve tank. If it has gone down, add coolant to the MAX mark. Put the cap back on tightly.

Low Oil Pressure Indicator, Charging System Indicator

Low Oil Pressure Indicator



This indicator should never come on when the engine is running. If it starts flashing or stays on, the oil pressure has dropped very low or lost pressure. Serious engine damage is possible, and you should take immediate action.

NOTICE

Running the engine with low oil pressure can cause serious mechanical damage almost immediately. Turn off the engine as soon as you can safely get the vehicle stopped.

1. Safely pull off the road, and shut off the engine. Turn on the hazard warning lights.
2. Let the vehicle sit for a minute. Open the hood, and check the oil level (see page 201). An engine very low on oil can lose pressure during cornering and other driving maneuvers.
3. If necessary, add oil to bring the level back to the full mark on the dipstick (see page 253).
4. Start the engine, and watch the oil pressure indicator. If it does not go out within 10 seconds, turn off the engine. There is a mechanical problem that needs to be repaired before you can continue driving (see **Emergency Towing** on page 311).

Charging System Indicator



If the charging system indicator comes on brightly when the engine is running, the battery is not being charged.

Immediately turn off all electrical accessories. Try not to use other electrically operated controls such as the power windows. Keep the engine running; starting the engine will discharge the battery rapidly.

Go to a service station or garage where you can get technical assistance.

Malfunction Indicator Lamp



If this indicator comes on while driving, it means one of the engine's emissions control systems may have a problem. Even though you may feel no difference in your vehicle's performance, it can reduce your fuel economy and cause increased emissions. Continued operation may cause serious damage.

If you have recently refueled your vehicle, the indicator coming on could be due to a loose or missing fuel fill cap. You will also see a "CHECK FUEL CAP" message on the information display. Tighten the cap until it clicks at least once. Tightening the cap will not turn the indicator off immediately; it can take several days of normal driving.

If the indicator comes on repeatedly, even though it may go off as you continue driving, have your vehicle checked by a dealer as soon as possible.

NOTICE

If you keep driving with the malfunction indicator lamp on, you can damage your vehicle's emissions controls and engine. Those repairs may not be covered by your vehicle's warranties.

If your vehicle has an automatic transmission, the malfunction indicator lamp may also come on with the "D" indicator.

Readiness Codes

Your vehicle has certain "readiness codes" that are part of the on-board diagnostics for the emissions systems. In some states, part of the emissions testing is to make sure these codes are set. If they are not set, the test cannot be completed.

If the battery in your vehicle has been disconnected or gone dead, these codes are erased. It can take several days of driving under various conditions to set the codes again.

To check if they are set, turn the ignition switch to the ON (II) position, without starting the engine. The malfunction indicator lamp will come on for 20 seconds. If it then goes off, the readiness codes are set. If it blinks five times, the readiness codes are not set. If possible, do not take your vehicle for an emissions test until the readiness codes are set. Refer to **Emissions Testing** for more information (see page 329).

Brake System Indicator

U.S.

Canada



Brake System Indicator (Red)

The brake system indicator (red) normally comes on when you turn the ignition switch to the ON (II) position, and as a reminder to check the parking brake. It will stay on if you do not fully release the parking brake.

If the brake system indicator (red) comes on while driving, the brake fluid level is probably low. Press lightly on the brake pedal to see if it feels normal. If it does, check the brake fluid level the next time you stop at a service station (see page 261).

If the fluid level is low, take your vehicle to a dealer, and have the brake system inspected for leaks or worn brake pads/shoes.

However, if the brake pedal does not feel normal, you should take immediate action. A problem in one part of the system's dual circuit design will still give you braking at two wheels. You will feel the brake pedal go down much farther before the vehicle begins to slow down, and you will have to press harder on the pedal.

Slow down by shifting to a lower gear, and pull to the side of the road when it is safe. Because of the long distance needed to stop, it is hazardous to drive the vehicle. You should have it towed and repaired as soon as possible (see **Emergency Towing** on page 311).

If you must drive the vehicle a short distance in this condition, drive slowly and carefully.

If the ABS indicator and the VSA system indicator (if equipped) come on with the brake system indicator, have your vehicle inspected by your dealer immediately.

Fuses

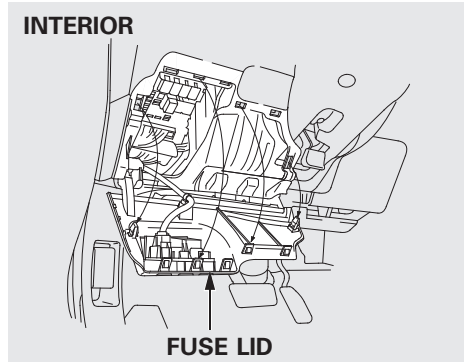

The vehicle's fuses are contained in two fuse boxes.

The interior fuse box is behind the fuse lid. To access it, pull the fuse lid toward you.

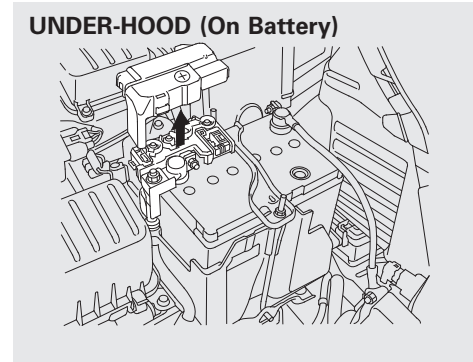
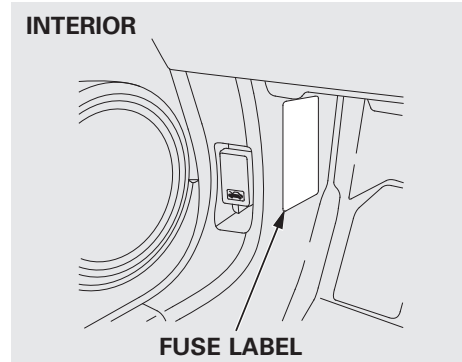

The under-hood fuse box is on the positive terminal of the battery.

Checking and Replacing Fuses

If something electrical in your vehicle stops working, check for a blown fuse first. Determine from the chart on pages 309 and 310, or the diagram on the fuse label, which fuse or fuses control that device. Check those fuses first, but check all the fuses before deciding that a blown fuse is the cause. Replace any blown fuses, and check if the device works.

1. Turn the ignition switch to the LOCK (0) position. Make sure the headlights and all other accessories are off.
2. On the under-hood fuse box, remove the cover from the fuse box. On the interior fuse box, pull the fuse lid toward you.

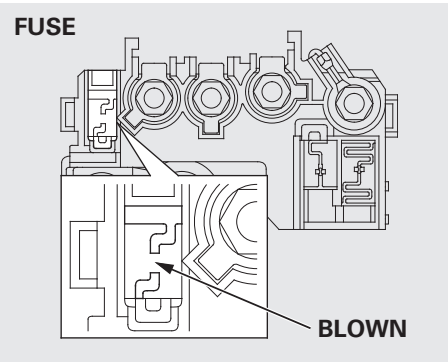

3. Check each of the large fuses in the under-hood fuse box and the interior fuse box by looking through the top at the wire inside.

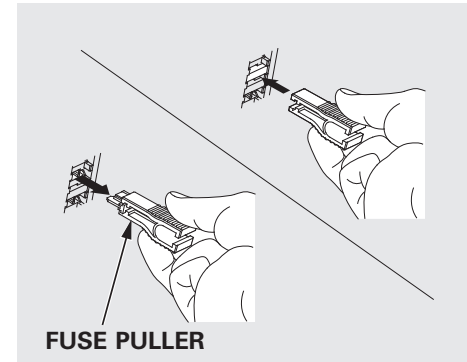

4. Check all smaller fuses in the interior fuse box by pulling out each one with the fuse puller provided in the interior fuse box.

CONTINUED

Fuses

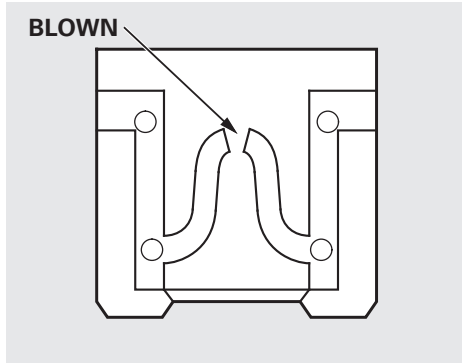

5. Look for a blown wire inside the fuse. If it is blown, replace it with one of the spare fuses of the same rating or lower.

If you cannot drive the vehicle without fixing the problem, and you do not have a spare fuse, take a fuse of the same rating or a lower rating from one of the other circuits. Make sure you can do without that circuit temporarily (such as the accessory power socket or radio).

If you replace the blown fuse with a spare fuse that has a lower rating, it might blow out again. This does not indicate anything wrong. Replace the fuse with one of the correct rating as soon as you can.

NOTICE

Replacing a fuse with one that has a higher rating greatly increases the chances of damaging the electrical system. If you do not have a replacement fuse with the proper rating for the circuit, install one with a lower rating.

6. If the replacement fuse of the same rating blows in a short time, there is probably a serious electrical problem in your vehicle. Leave the blown fuse in that circuit and have your vehicle checked by a qualified technician.

On vehicles without navigation system

If the radio fuse is removed, the audio system will disable itself. The next time you turn on the radio you will see “ENTER CODE” in the frequency display. Use the preset buttons to enter the code (see page 191).

When the audio system is disabled, the clock setting in the audio system will be canceled. You will need to reset the clock (see page 192).

On vehicles with navigation system

The navigation system will also disable itself. The next time you turn on the ignition switch, the system will require you to enter “ENTER CODE” before it can be used. Refer to the navigation system manual.

Fuse Locations

INTERIOR FUSE BOX

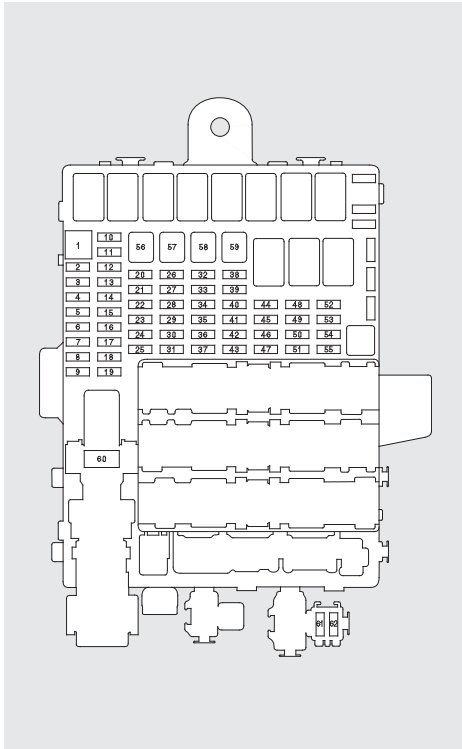

No.	Amps.	Circuits Protected
1	10 A	Back Up
2	(7.5 A)	TPMS*
3	20 A	Driver's Power Window
4	–	Not Used
5	10 A	Back Up Light
6	10 A	SRS
7	(10 A)	Transmission SOL*
8	7.5 A	SRS
9	(20 A)	Fog Light*
10	7.5 A	A/C*
11	7.5 A	ABS/VSA*
12	10 A	ACG
13	20 A	ACC Socket
14	7.5 A	Key Lock/Radio
15	7.5 A	Daytime Running Light
16	10 A	Rear Wiper
17	20 A	Front Passenger's Power Window
18	20 A	Rear Passenger's Side Power Window
19	20 A	Rear Driver's Side Power Window
20	15 A	Fuel Pump
21	15 A	Washer
22	7.5 A	Meter
23	10 A	Hazard
24	10 A	Stop/Horn
25	–	Not Used

No.	Amps.	Circuits Protected
26	10 A	LAF
27	(30 A)	Door Lock Main*
28	20 A	Headlight Main
29	10 A	Small Light
30	30 A	Main Fan Motor
31	–	Not Used
32	10 A	Right Headlight Low Beam
33	15 A	IG Coil
34	10 A	Left Headlight Low Beam
35	(15 A)	Door Lock*
36	(15 A)	Door Lock*
37	30 A	ABS/VSA* FSR
38	(15 A)	Door Lock*
39	15 A	IGP
40	–	Not Used
41	–	Not Used
42	–	Not Used
43	(7.5 A)	MG Clutch
44	7.5 A	STS
45	–	Not Used
46	–	Not Used
47	(30 A)	Sub Fan Motor
48	10 A	Left Headlight High Beam
49	(15 A)	Door Lock*
50	(15 A)	Door Lock*

*: If equipped

Taking Care of the Unexpected

CONTINUED

Fuse Locations

No.	Amps.	Circuits Protected
51	10 A	Right Headlight High Beam
52	15 A	DBW
53	–	Not Used
54	20 A	Rear Defogger*
55	10 A	Heated Mirror*
56	30 A	Front Wiper
57	30 A	Blower Motor
58	30 A	ABS/VSA* Motor
59	20 A	Rear Defogger
	30 A	
60	50 A/ 40 A	IG Main/Option Main
61	30 A	Radio
62	–	Not Used

*: If equipped

UNDER-HOOD FUSE BOX

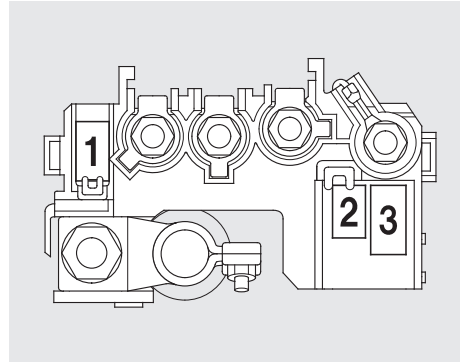

Under-hood Fuse Box (On the battery)

Amps.	Circuits Protected
100 A	Battery
70 A	EPS
20 A	Horn/Hazard

If your vehicle needs to be towed, call a professional towing service or organization. Never tow your vehicle with just a rope or chain. It is very dangerous.

There are two ways to tow your vehicle:

Flat-bed Equipment – The operator loads your vehicle on the back of a truck. **This is the best way to transport your vehicle.**

Wheel-lift Equipment – The tow truck uses two pivoting arms that go under the front tires and lift them off the ground. The rear tires remain on the ground. **This is an acceptable way to tow your vehicle.**

If, due to damage, your vehicle must be towed with the front wheels on the ground, do this:

Manual transmission:

- Release the parking brake.
- Shift the transmission to neutral.
- Leave the ignition switch in the ACCESSORY (I) position so the steering wheel does not lock.

Automatic transmission:

- Release the parking brake.
- Start the engine.
- Shift to D position and hold for 5 seconds, then to N. Let the engine run for 3 minutes, then turn it off.
- Turn off the engine.
- Leave the ignition switch in the ACCESSORY (I) position so the steering wheel does not lock.

NOTICE

Improper towing preparation will damage the transmission. Follow the above procedure exactly. If you cannot shift the transmission or start the engine (automatic transmission), your vehicle must be transported with the front wheels off the ground.

With the front wheels on the ground, it is best to tow the vehicle no farther than 50 miles (80 km), and keep the speed below 35 mph (55 km/h).

CONTINUED

Emergency Towing, If Your Vehicle Gets Stuck

NOTICE

Trying to lift or tow your vehicle by the bumpers will cause serious damage. The bumpers are not designed to support the vehicle's weight.

NOTICE

The steering system can be damaged if the steering wheel is locked. Leave the ignition switch in the ACCESSORY (I) position, and make sure the steering wheel turns freely before you begin towing.

If Your Vehicle Gets Stuck

If your vehicle gets stuck in sand, mud, or snow, call a towing service to pull it out (see page 311).

For very short distances, such as freeing the vehicle, you can use the detachable towing hook that mounts on the anchor in the front bumper.

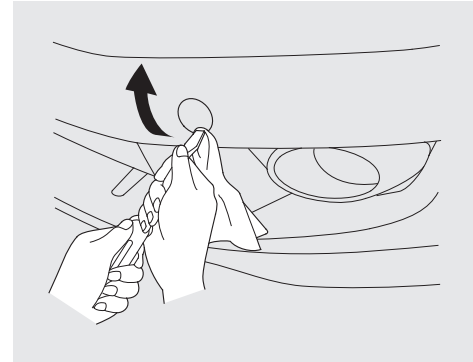

To use the towing hook:

1. Take the towing hook and the extension out of the tool kit in the cargo area.
2. Put a cloth on the notch of the cover. Using the extension, carefully pry on the notch of the cover to remove it.

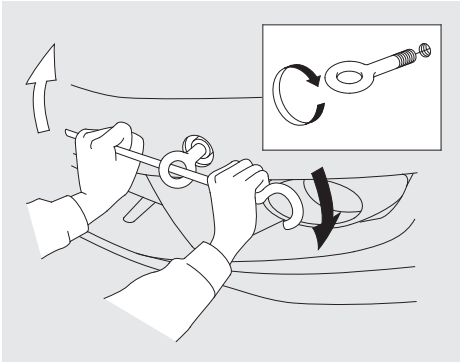

3. Screw the towing hook into the bolt hole behind the bumper, then tighten the hook securely with the extension.

NOTICE

To avoid damage to your vehicle, use the towing hook for straight, flat ground towing only. Do not tow at an angle. The tow hook should not be used to tow the vehicle onto a flat bed. Do not use it as a tie down.

The diagrams in this section give you the dimensions and capacities of your vehicle and the locations of the identification numbers. It also includes information you should know about your vehicle's tires and emissions control systems.

- Identification Numbers 316
- Specifications 318
- DOT Tire Quality Grading (U.S. Vehicles) 321
- Uniform Tire Quality Grading..... 321
- Treadwear..... 321
- Traction 321
- Temperature 322
- Tire Labeling 323
- Tire Pressure Monitoring System (TPMS) – Required Federal Explanation 324
- Emissions Controls 326
- The Clean Air Act..... 326
- Crankcase Emissions Control System..... 326
- Evaporative Emissions Control System..... 326
- Onboard Refueling Vapor Recovery 326
- Exhaust Emissions Controls 327
- Replacement Parts 327

- Three Way Catalytic Converter..... 328
- Emissions Testing..... 329

Identification Numbers

Your vehicle has several identifying numbers in various places.

The vehicle identification number (VIN) is the 17-digit number your dealer uses to register your vehicle for warranty purposes. It is also necessary for licensing and insuring your vehicle. The easiest place to find the VIN is on a plate fastened to the top of the dashboard. You can see it by looking through the windshield on the driver's side. It is also on the certification label attached to the driver's doorjamb, and is stamped on the engine compartment bulkhead. The VIN is also provided in bar code on the certification label.

The VIN is also located on the engine bulkhead. Slide the cover on the engine compartment bulkhead to view the VIN. Always close the cover when finished.

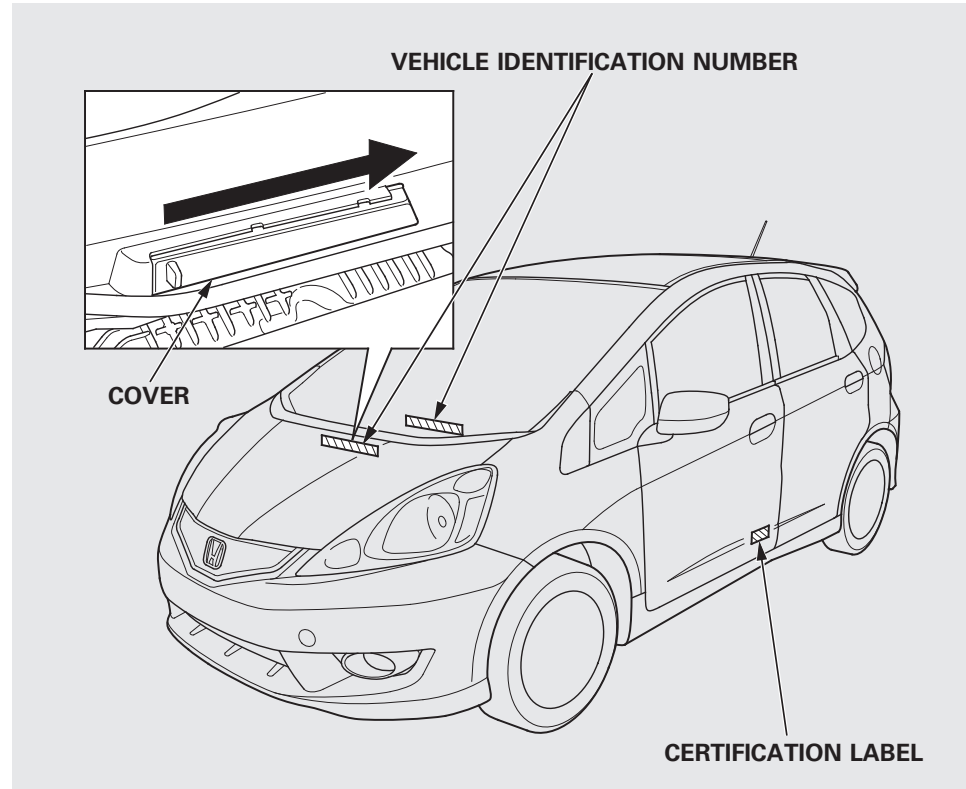

Identification Numbers

The engine number is stamped into the front of the engine block.

The transmission number is on a label on top of the transmission.

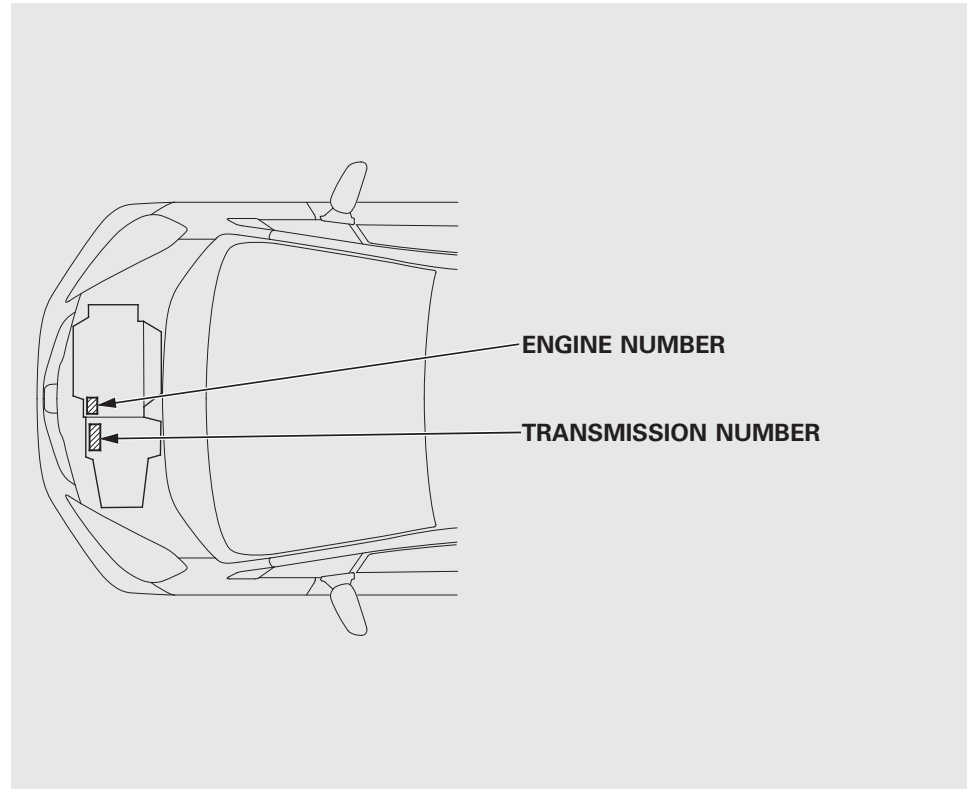

Specifications

Dimensions

Length		161.6 in (4,105 mm)
Width		66.7 in (1,695 mm)
Height		60.0 in (1,525 mm)
Wheelbase		98.4 in (2,500 mm)
Track	Front	58.7 in (1,492 mm)* ¹ 58.1 in (1,476 mm)* ²
	Rear	58.1 in (1,475 mm)* ¹ 57.4 in (1,459 mm)* ²

*1: All models except Sport

*2: Sport model

Weights

Gross vehicle weight rating	See the certification label attached to the driver's doorjamb.
-----------------------------	--

Seating Capacities

Total	5
Front	2
Rear	3

Engine

Type	Water cooled 4-stroke SOHC i-VTEC 4-cylinder gasoline engine
Bore x Stroke	2.87 x 3.52 in (73.0 x 89.4 mm)
Displacement	91.3 cu-in (1,497 cm ³)
Compression ratio	10.4 : 1
Spark plugs	IZFR6K13 (NGK) SKJ20DR-M13 (DENSO)

Specifications

Capacities

Fuel tank		Approx. 10.6 US gal (40 L)
Engine oil	Change* ¹	
	Including filter	3.8 US qt (3.6 L)
	Without filter	3.6 US qt (3.4 L)
	Total	4.4 US qt (4.2 L)
Engine coolant	Automatic transmission	
	Change* ²	1.19 US gal (4.5 L)
	Total	1.32 US gal (5.0 L)
	Manual transmission	
	Change* ²	1.16 US gal (4.4 L)
	Total	1.29 US gal (4.9 L)
Automatic transmission fluid	Change	2.6 US qt (2.5 L)
	Total	6.18 US qt (5.85 L)
Manual transmission fluid	Change	1.6 US qt (1.5 L)
	Total	1.7 US qt (1.6 L)
Windshield washer reservoir	U.S. Vehicles	2.6 US qt (2.5 L)
	Canada Vehicles	4.8 US qt (4.5 L)

*1: Excluding the oil remaining in the engine

*2: Including the coolant in the reserve tank and that remaining in the engine
Reserve tank capacity:
0.116 US gal (0.44 L)

Air Conditioning

Refrigerant type	HFC-134a (R-134a)
Charge quantity	13.1–14.8 oz (370–420 g)
Lubricant type	SP-10

Lights

Headlights	High/Low	12 V – 60/55 W (HB2)
Front turn signal lights		12 V – 21 W (Amber)
Parking lights/side marker lights		12 V – 3.8 W (Amber)
Fog lights*		12 V – 55 W (H11)
Rear turn signal lights		12 V – 21 W (Amber)
Stop/Taillights		12 V – 21/5 W
Back-up lights		12 V – 16 W
License plate lights		12 V – 5 W
Ceiling light		12 V – 8 W
Cargo area light		12 V – 5 W
Map light*		12 V – 8 W
High-mount brake light		LED

*: For some types

Specifications

Battery

Capacity	12 V — 32 AH/5 HR 12 V — 34 AH/5 HR 12 V — 40 AH/20 HR
----------	--

Fuses

Interior	See page 309 or the fuse label attached to the dashboard.
Under-hood	See page 310 or the fuse box cover.

Alignment

Toe-in	Front	0.0 in (0 mm)
	Rear	0.10 in (2.5 mm)
Camber	Front	0°
	Rear	-1°
Caster	Front	3°20'

Tires

Size	Front/Rear	175/65R15 84S* ¹
		185/55R16 83H* ²
	Spare	T125/70D15 95M* ³
		T135/80D15 99M* ⁴
Pressure	Front/Rear	32 psi (220 kPa, 2.2 kgf/cm ²)* ¹
		33 psi (230 kPa, 2.3 kgf/cm ²)* ²
	Spare	60 psi (420 kPa, 4.2 kgf/cm ²)

*1: All models except Sport

*2: Sport model

*3: On models without VSA system and all Canadian models with manual transmission

*4: On models with VSA system

DOT Tire Quality Grading (U.S. Vehicles)

The tires on your vehicle meet all U.S. Federal Safety Requirements. All tires are also graded for treadwear, traction, and temperature performance according to Department of Transportation (DOT) standards. The following explains these gradings.

Uniform Tire Quality Grading

Quality grades can be found where applicable on the tire sidewall between tread shoulder and maximum section width. For example:

Treadwear 200

Traction AA

Temperature A

All passenger car tires must conform to Federal Safety Requirements in addition to these grades.

Treadwear

The treadwear grade is a comparative rating based on the wear rate of the tire when tested under controlled conditions on a specified government test course. For example, a tire graded 150 would wear one and one-half (1 1/2) times as well on the government course as a tire graded 100. The relative performance of tires depends upon the actual conditions of their use, however, and may depart significantly from the norm due to variations in driving habits, service practices and differences in road characteristics and climate.

Traction

The traction grades, from highest to lowest, are AA, A, B, and C. Those grades represent the tire's ability to stop on wet pavement as measured under controlled conditions on specified government test surfaces of asphalt and concrete. A tire marked C may have poor traction performance.

Warning: The traction grade assigned to this tire is based on straight-ahead braking traction tests, and does not include acceleration, cornering, hydroplaning, or peak traction characteristics.

DOT Tire Quality Grading (U.S. Vehicles)

Temperature

The temperature grades are A (the highest), B, and C, representing the tire's resistance to the generation of heat and its ability to dissipate heat when tested under controlled conditions on a specified indoor laboratory test wheel. Sustained high temperature can cause the material of the tire to degenerate and reduce tire life, and excessive temperature can lead to sudden tire failure. The grade C corresponds to a level of performance which all passenger car tires must meet under the Federal Motor Vehicle Safety Standard No. 109. Grades B and A represent higher levels of performance on the laboratory test wheel than the minimum required by law.

Warning: The temperature grade for this tire is established for a tire that is properly inflated and not overloaded. Excessive speed, underinflation, or excessive loading, either separately or in combination, can cause heat buildup and possible tire failure.

The tires that came on your vehicle have a number of markings. Those you should be aware of are described below.

TIRE LABELING EXAMPLE

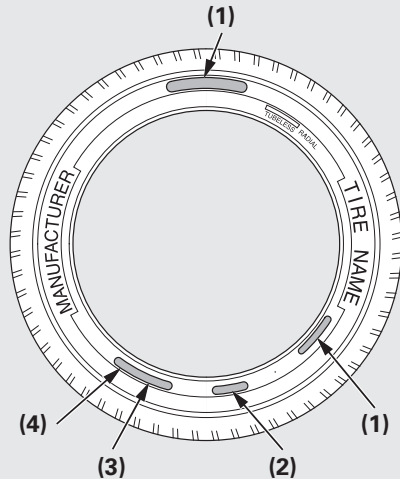

- (1) Tire Size
- (2) Tire Identification Number (TIN)
- (3) Maximum Tire Pressure
- (4) Maximum Tire Load

Tire Size

Whenever tires are replaced, they should be replaced with tires of the same size. Below is an example of tire size with an explanation of what each component means.

185/55R16 83H

- 185 – Tire width in millimeters.
- 55 – Aspect ratio (the tire's section height as a percentage of its width).
- R – Tire construction code (R indicates radial).
- 16 – Rim diameter in inches.
- 83 – Load index (a numerical code associated with the maximum load the tire can carry).
- H – Speed symbol (an alphabetical code indicating the maximum speed rating).

Tire Identification Number (TIN)

The tire identification number (TIN) is a group of numbers and letters that look like the following example. TIN is located on the sidewall of the tire.

DOT B97R FW6X 2202

- DOT – This indicates that the tire meets all requirements of the U.S. Department of Transportation.
- B97R – Manufacturer's identification mark.
- FW6X – Tire type code.
- 2202 – Date of manufacture.
 - 22 – Year
 - 02 – Week

CONTINUED

Tire Labeling, Tire Pressure Monitoring System (TPMS) – Required Federal Explanation

Glossary of Tire Terminology

Cold Tire Pressure - The tire air pressure when the vehicle has been parked for at least three hours or driven less than 1 mile (1.6km).

Load Rating - Means the maximum load that a tire is rated to carry for a given inflation pressure.

Maximum Inflation Pressure - the maximum tire air pressure that the tire can hold.

Maximum Load Rating - Means the load rating for a tire at the maximum permissible inflation pressure for that tire.

Recommended Inflation Pressure - The cold tire inflation pressure recommended by the manufacturer.

Treadwear Indicators (TWI) - Means the projections within the principal grooves designed to give a visual indication of the degrees of wear of the tread.

Tire Pressure Monitoring System (TPMS) – Required Federal Explanation

U.S. models only

Each tire, including the spare (if provided), should be checked monthly when cold and inflated to the inflation pressure recommended by the vehicle manufacturer on the vehicle placard or tire inflation pressure label.

(If your vehicle has tires of a different size than the size indicated on the vehicle placard or tire inflation pressure label, you should determine the proper tire inflation pressure for those tires.)

As an added safety feature, your vehicle has been equipped with a tire pressure monitoring system (TPMS) that illuminates a low tire pressure telltale



when one or more of your tires is significantly under-inflated.

Accordingly, when the low tire pressure telltale illuminates, you should stop and check your tires as soon as possible, and inflate them to the proper pressure.

Tire Pressure Monitoring System (TPMS) – Required Federal Explanation

Driving on a significantly under-inflated tire causes the tire to overheat and can lead to tire failure. Under-inflation also reduces fuel efficiency and tire tread life, and may affect the vehicle's handling and stopping ability.

Please note that the TPMS is not a substitute for proper tire maintenance, and it is the driver's responsibility to maintain correct tire pressure, even if under-inflation has not reached the level to trigger illumination of the TPMS low tire pressure telltale.

Your vehicle has also been equipped with a TPMS malfunction indicator to indicate when the system is not operating properly. The TPMS malfunction indicator is provided by a separate telltale, which displays the symbol “TPMS” when illuminated.

When the malfunction indicator is illuminated,



TPMS

the system may not be able to detect or signal low tire pressure as intended.

TPMS malfunctions may occur for a variety of reasons, including the installation of replacement or alternate tires or wheels on the vehicle that prevent the TPMS from functioning properly.

Always check the TPMS malfunction telltale after replacing one or more tires or wheels on your vehicle to ensure that the replacement or alternate tires and wheels allow the TPMS to continue to function properly.

Emissions Controls

The burning of gasoline in your vehicle's engine produces several byproducts. Some of these are carbon monoxide (CO), oxides of nitrogen (NOx), and hydrocarbons (HC). Gasoline evaporating from the tank also produces hydrocarbons. Controlling the production of NOx, CO, and HC is important to the environment. Under certain conditions of sunlight and climate, NOx and HC react to form photochemical "smog." Carbon monoxide does not contribute to smog creation, but it is a poisonous gas.

The Clean Air Act

The United States Clean Air Act* sets standards for automobile emissions. It also requires that automobile manufacturers explain to owners how their emissions controls work and what to do to maintain them. This section summarizes how the emissions controls work.

* In Canada, Honda vehicles comply with the Canadian emission requirements, as specified in an agreement with Environment Canada, at the time they are manufactured.

Crankcase Emissions Control System

Your vehicle has a positive crankcase ventilation system. This keeps gasses that build up in the engine's crankcase from going into the atmosphere. The positive crankcase ventilation valve routes them from the crankcase back to the intake manifold. They are then drawn into the engine and burned.

Evaporative Emissions Control System

As gasoline evaporates in the fuel tank, an evaporative emissions control canister filled with charcoal adsorbs the vapor. It is stored in this canister while the engine is off. After the engine is started and warmed up, the vapor is drawn into the engine and burned during driving.

Onboard Refueling Vapor Recovery

The onboard refueling vapor recovery (ORVR) system captures the fuel vapors during refueling. The vapors are adsorbed in a canister filled with activated carbon. While driving, the fuel vapors are drawn into the engine and burned off.

Exhaust Emissions Controls

The exhaust emissions controls include four systems: PGM-FI, ignition timing control, exhaust gas recirculation, and three way catalytic converter. These four systems work together to control the engine's combustion and minimize the amount of HC, CO, and NOx that come out the tailpipe. The exhaust emissions control systems are separate from the crankcase and evaporative emissions control systems.

PGM-FI System

The PGM-FI system uses sequential multiport fuel injection. It has three subsystems: air intake, engine control, and fuel control. The powertrain control module (PCM) in automatic transmission vehicles or the engine control module (ECM) in manual transmission vehicles uses various sensors to determine how much air is going into the engine. It then controls how much fuel to inject under all operating conditions.

Ignition Timing Control System

This system constantly adjusts the ignition timing, reducing the amount of HC, CO, and NOx produced.

Exhaust Gas Recirculation (EGR) System

The exhaust gas recirculation (EGR) system takes some of the exhaust gas and routes it back into the intake manifold. Adding exhaust gas to the air/fuel mixture reduces the amount of NOx produced when the fuel is burned.

Three Way Catalytic Converter

The three way catalytic converter is in the exhaust system. Through chemical reactions, it converts HC, CO, and NOx in the engine's exhaust to carbon dioxide (CO₂), nitrogen (N₂), and water vapor.

Replacement Parts

The emissions control systems are designed and certified to work together in reducing emissions to levels that comply with the Clean Air Act. To make sure the emissions remain low, you should use only new Honda replacement parts or their equivalent for repairs. Using lower quality parts may increase the emissions from your vehicle.

The emissions control systems are covered by warranties separate from the rest of your vehicle. Read your warranty manual for more information.

Three Way Catalytic Converter

The three way catalytic converter contains precious metals that serve as catalysts, promoting chemical reactions to convert the exhaust gasses without affecting the metals. The catalytic converter is referred to as a three-way catalyst, since it acts on HC, CO, and NOx. A replacement unit must be an original Honda part or its equivalent.

The three way catalytic converter must operate at a high temperature for the chemical reactions to take place. It can set on fire any combustible materials that come near it. Park your vehicle away from high grass, dry leaves, or other flammables.

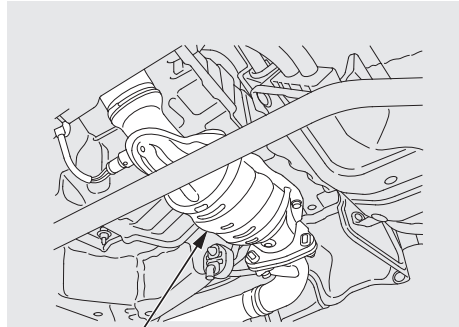

THREE WAY CATALYTIC CONVERTER

A defective three way catalytic converter contributes to air pollution, and can impair your engine's performance. Follow these guidelines to protect your vehicle's three way catalytic converter.

- Keep the engine well maintained.
- Have your vehicle diagnosed and repaired if it is misfiring, backfiring, stalling, or otherwise not running properly.
- Always use unleaded gasoline. Even a small amount of leaded gasoline can contaminate the catalyst metals, making the three way catalytic converter ineffective.

Testing of Readiness Codes

If you take your vehicle for an emissions test shortly after the battery has been disconnected or gone dead, it may not pass the test. This is because of certain “readiness codes” that must be set in the on-board diagnostics for the emissions systems. These codes are erased when the battery is disconnected, and set again only after several days of driving under a variety of conditions.

If the testing facility determines that the readiness codes are not set, you will be requested to return at a later date to complete the test. If you must get the vehicle retested within the next two or three days, you can condition the vehicle for retesting by doing the following.

1. Make sure the gas tank is nearly, but not completely, full (around 3/4).
2. Make sure the vehicle has been parked with the engine off for 6 hours or more.
3. Make sure the ambient temperature is between 40° and 95° F.
4. Without touching the accelerator pedal, start the engine, and let it idle for 20 seconds.
5. Keep the vehicle in Park (automatic transmission) or neutral (manual transmission). Increase the engine speed to 2,000 rpm, and hold it there until the temperature gauge rises to at least 1/4 of the scale (about 3 minutes).
6. Without touching the accelerator pedal, let the engine idle for 20 seconds.

CONTINUED

Emissions Testing

7. Select a nearby lightly traveled major highway where you can maintain a speed of 50 to 60 mph (80 to 97 km/h) for at least 20 minutes. Drive on the highway in D (automatic) or 5th (manual). Do not use the cruise control. When traffic allows, drive for 90 seconds without moving the accelerator pedal. (Vehicle speed may vary slightly; this is okay.) If you cannot do this for a continuous 90 seconds because of traffic conditions, drive for at least 30 seconds, then repeat it two more times (for a total of 90 seconds).

8. Then drive in city/suburban traffic for at least 10 minutes. When traffic conditions allow, let the vehicle coast for several seconds without using the accelerator pedal or the brake pedal.

9. Make sure the vehicle has been parked with the engine off for 30 minutes.

If the testing facility determines the readiness codes are still not set, see your dealer.

Warranty and Customer Relations

Customer Service Information	332
Warranty Coverages	333
Reporting Safety Defects (U.S. Vehicles).....	334
Authorized Manuals.....	335

Customer Service Information

Honda dealership personnel are trained professionals. They should be able to answer all your questions. If you encounter a problem that your dealership does not solve to your satisfaction, please discuss it with the dealership's management. The service manager or general manager can help. Almost all problems are solved in this way.

If you are dissatisfied with the decision made by the dealership's management, contact Honda Customer Service.

U.S. Owners:

American Honda Motor Co., Inc.
Automobile Customer Service
Mail Stop 500-2N-7A
1919 Torrance Boulevard
Torrance, California 90501-2746

Tel: (800) 999-1009

Canadian Owners:
Customer Relations
Honda Canada Inc.

Visit www.honda.ca for contact information

Tel: 1-888-9-HONDA-9
Fax: 1-877-939-0909

In Puerto Rico and the U.S. Virgin Islands:

Bella International
P.O. Box 190816
San Juan, PR 00919-0816

Tel: (787) 620-7546

When you call or write, please give us this information:

- Vehicle Identification Number (see page 316)
- Name and address of the dealer who services your vehicle
- Date of purchase
- Odometer reading of your vehicle
- Your name, address, and telephone number
- A detailed description of the problem
- Name of the dealer who sold the vehicle to you

Warranty Coverages

U.S. Owners

Your new vehicle is covered by these warranties:

New Vehicle Limited Warranty – covers your new vehicle, except for the battery, emissions control systems, and accessories against defects in materials and workmanship.

Emissions Control Systems Defects Warranty and Emissions Performance Warranty – these two warranties cover your vehicle's emissions control systems. Time, mileage, and coverage are conditional. Please read your warranty booklet for exact information.

Original Equipment Battery Limited Warranty – this warranty gives up to 100% credit toward a replacement battery.

Seat Belt Limited Warranty – a seat belt that fails to function properly is covered by a limited warranty. Please read your warranty booklet for details.

Rust Perforation Limited Warranty – all exterior body panels are covered for rust-through from the inside for the specified time period with no mileage limit.

Accessory Limited Warranty – Honda accessories are covered under this warranty. Time and mileage limits depend on the type of accessory and other factors. Please read your warranty booklet for details.

Replacement Parts Limited Warranty – covers all Honda replacement parts against defects in materials and workmanship.

Replacement Battery Limited Warranty – provides prorated coverage for a replacement battery purchased from your dealer.

Replacement Muffler Lifetime Limited Warranty – provides coverage for as long as the purchaser of the muffler owns the vehicle.

Restrictions and exclusions apply to all these warranties. Please read the 2010 Honda warranty information booklet that came with your vehicle for precise information on warranty coverages. Your vehicle's original tires are covered by their manufacturer. Tire warranty information is in a separate booklet.

Canadian Owners

Please refer to the 2010 warranty manual that came with your vehicle.

Reporting Safety Defects (U.S. Vehicles)

If you believe that your vehicle has a defect which could cause a crash or could cause injury or death, you should immediately inform the National Highway Traffic Safety Administration (NHTSA) in addition to notifying American Honda Motor Co., Inc.

If NHTSA receives similar complaints, it may open an investigation, and if it finds that a safety defect exists in a group of vehicles, it may order a recall and remedy campaign. However, NHTSA cannot become involved in individual problems between you, your dealer, or American Honda Motor Co., Inc.

To contact NHTSA, you may call the Vehicle Safety Hotline toll-free at 1-888-327-4236 (TTY: 1-800-424-9153); go to <http://www.safercar.gov>; or write to: Administrator, NHTSA, 1200 New Jersey Avenue, SE., Washington, DC 20590. You can also obtain other information about motor vehicle safety from <http://www.safercar.gov>.

Purchasing Factory Authorized Manuals (U.S. only)

The publications shown below can be purchased from Helm Incorporated. You can order by phone or online:

- Call Helm Inc. at 1-800-782-4356 (credit card orders only)
- Go online at www.helminc.com

If you are interested in other years or models, contact Helm Inc. at 1-800-782-4356.

Publication Form Number	Form Description
61TK610	2010 Honda Fit Service Manual
61TK601EL	2010 Honda Fit Electrical Troubleshooting Manual
61TK630	2009 Honda Fit Body Repair Manual
31TK6610	2010 Honda Fit Owner's Manual
31TK6810	2010 Honda Fit Navigation System Owner's Manual
31TK6M10	2010 Honda Fit Honda Service History
31TK6Q10	2010 Honda Fit Technology Reference Guide
HON-R	Order Form for Previous Years- Indicate Year and Model Desired

Service Manual:

Covers maintenance and recommended procedures for repair to engine and chassis components. It is written for the journeyman mechanic, but it is simple enough for most mechanically inclined owners to understand.

Electrical Troubleshooting Manual:

Complements the Service Manual by providing in-depth troubleshooting information for each electrical circuit in your vehicle.

Body Repair Manual:

Describes the procedures involved in the replacement of damaged body parts.

A

Accessories and Modifications	206
ACCESSORY (Ignition Key Position)	80
Accessory Power Socket	106
Additives, Engine Oil	254
Adjusting the Steering Wheel	77
Advanced Airbags	27
Airbag (SRS)	9, 22
Air Conditioning System	110
Usage	112
Air Pressure, Tires	273, 274
Alcohol in Gasoline	198
Antifreeze	256
Anti-lock Brakes (ABS)	
Indicator Light	62, 231
Operation	231
Anti-theft, Audio System	191
Anti-theft Steering Column	
Lock	80
Audio Antenna	268
Auto Door Locking	83
Auto Door Locking/Unlocking	83

Auto Door Unlocking	85
Automatic Seat Belt Tensioners ...	20
Automatic Speed Control	194
Automatic Transmission	219
Capacity, Fluid	319
Checking Fluid Level	259
Paddle Shifters	224
Shifting	219
Shift Lever Position	
Indicators	219
Shift Lever Positions	220
Shift Lock Release	223
Automatic Transmission Fluid ...	259
Auxiliary Input Jack	190
Average Fuel Economy	70

B

Battery	
Charging System	
Indicator	60, 303
Jump Starting	299
Maintenance	279
Specifications	320
Before Driving	197

Belts, Seat	8, 18
Beverage Holders	106
Booster Seats	50
Brakes	
Anti-lock Brakes (ABS)	231
Break-in, New Linings	198
Bulb Replacement	266
Fluid	261
Parking	102
System Design	230
System Indicator	60, 305
Wear Indicators	230
Braking System	230
Break-in, New Vehicle	198
Brightness Control,	
Instruments	76

CONTINUED

Index

Bulb Replacement	
Back-up Lights	266
Brake Lights	266
Fog Lights	265
Front Parking Lights	263
Front Side Marker Lights	263
Front Turn Signal Lights	264
Headlights	262
Rear Bulbs	266
Specifications	319
Taillights	266
Turn Signal Lights	263, 266
Bulbs, Halogen	262

C

Capacities Chart	319
Carbon Monoxide Hazard	53
Cargo	208
Cargo Hook	212
Cargo, How to Carry	208
Carrying Cargo	208
CAUTION, Explanation of	iii
CD Care	186
CD Error Messages	128, 157

CD Player	122, 149
Ceiling Light	107
Certification Label	316
Chains, Tires	278
Changing a Flat Tire	285
Changing Oil	
How to	254
When to	245
Charging System	
Indicator	60, 303
Check Fuel Cap Indicator	70
Checklist, Before Driving	215
Childproof Door Locks	82
Child Safety	34
Booster Seats	50
Child Seats	39, 40, 41
Important Safety Reminders	38
Infants	39
Larger Children	49
LATCH	43
Risks with Airbags	35
Small Children	40
Tethers	47
Warning Labels	36
Where Should a Child Sit?	35

Child Seats	34, 41
LATCH Anchorage Points	43
Tether Anchorage Points	47
Cleaning the Seat Belts	267
Clock	192
Clutch Fluid	261
Code, Audio System	191
CO in the Exhaust	53, 326
Cold Weather, Starting in	216
Compact Spare Tire	284
Controls, Instruments and	57
Coolant	
Adding	256
Checking	202
Proper Solution	256
Temperature Indicator	63
Crankcase Emissions Control	
System	326
Cruise Control Indicator	65
Cruise Control Operation	194
Cruise Main Indicator	65
Cup Holders	106
Customer Service	332

D

DANGER, Explanation of	iii
Dashboard	3, 58
Daytime Running Lights (Canada only)	75
Daytime Running Lights Indicator	65
Dead Battery	299
Defects, Reporting Safety (U.S. only)	334
Defogger, Rear Window	76
Defrosting the Windows	113
Detachable Anchor	99
Dimensions	318
Dimming the Headlights	74
Dipstick	
Automatic Transmission	259
Engine Oil	201
Directional Signals	63, 74
Disc Brake Wear Indicators	230
Disc Care	186
Disc Player Error	
Messages	128, 157
Disposal of Used Oil	255

Doors	
Auto Door Locking/Unlocking	83
Childproof Door Locks	82
Locking and Unlocking	81
Power Door Locks	81
DOT Tire Quality Grading (U.S. Vehicles)	321
Downshifting, Manual	
Transmission	217
Driver and Passenger Safety	5
Driving	213
Economy	203
Driving Guidelines	214
Driving with the Paddle Shifters (Sport only)	224
Dust and Pollen Filter	268

E

Economy, Fuel	203
Electric Power Steering (EPS) Indicator	62
Emergencies on the Road	283
Battery, Jump Starting	299

Brake System Indicator	60, 305
Changing a Flat Tire	285
Charging System	
Indicator	60, 303
Checking the Fuses	307
Driving with a Flat Tire	284
Hazard Warning Flashers	76
Jump Starting	299
Low Oil Pressure	
Indicator	60, 303
Malfunction Indicator	
Lamp	60, 304
Overheated Engine	301
Towing	311
Emergency Brake	102
Emergency Flashers	76
Emergency Towing	311
Emissions Controls	326
Emissions Testing	329

Index

Engine	
Adding Engine Coolant	256
Coolant Temperature	
Indicator	63
If it Won't Start	297
Malfunction Indicator	
Lamp	60, 304
Oil Life Indicator	245
Oil Pressure Indicator	60, 303
Oil, What Kind to Use	253
Overheating	301
Specifications	318
Speed Limiter	218, 222
Starting	216
Engine Coolant	256
Engine Number	317
Ethanol in Gasoline	198
Evaporative Emissions	
Controls	326
Exhaust Emissions Controls	327
Exhaust Fumes	53
Expectant Mothers, Use of Seat	
Belts by	16

F

Fan, Interior	111
Features	109
Filters	
Dust and Pollen	268
Oil	254
Flashers, Hazard Warning	76
Flat Tire, Changing a	285
Floor Mats	267
Fluids	
Automatic Transmission	259
Brake	261
Clutch	261
Location	252
Manual Transmission	260
Windshield Washer	258
FM/AM Radio Reception	184
Four-way Flashers	76
Front Airbags	9, 25
Front Seat	
Adjusting	93
Fuel	198
Check Fuel Cap Indicator	70
Economy	203

Fill Door and Cap	199
Gauge	70
Low Fuel Indicator	62
Octane Requirement	198
Reserve Indicator	62
Tank, Filling the	199
Fuel Economy	203
Fuses, Checking the	307

G

Gas Mileage, Improving	204
Gasoline	198
Low Fuel Indicator	62
Octane Requirement	198
Tank, Refueling	199
Gas Station Procedures	199
Gauges	
Fuel	70
Odometer	70
Speedometer	68
Tachometer	68
Gearshift Lever Positions	
Automatic	
Transmission	219, 220

Index

Manual Transmission	217
Glove Box	105
Gross Vehicle Weight Rating (GVWR)	210

H

Halogen Headlight Bulbs	262
Hazard Warning Flashers	76
Headlights	74, 75
Aiming	262
Daytime Running Lights (Canada only)	75
High Beam Indicator	65
High Beams, Turning on	74
Lights On Indicator	64
Low Beams, Turning on	74
Reminder Chime	74, 75
Replacing Halogen Bulbs	262
Turning on	74
Head Restraints	94
Heated Mirror	102
Heating and Cooling	110
High Altitude, Starting at	216
High Beam Lever	75

High-Low Beam Switch	74
Hood, Opening and Closing the	200
Horn	4, 72
Hydraulic Clutch	261

I

Identification Number, Vehicle	316
Ignition Keys	78
Switch	80
Timing Control System	327
Immobilizer System	79
Important Safety Precautions	6
Indicators, Instrument Panel	59
ABS (Anti-lock Brake)	62, 231
Brake (Parking and Brake System)	60, 305
Charging System	60, 303
Check Fuel Cap	70
Cruise Control	65
Cruise Main	65
Door and Tailgate Open	62

DRL (Daytime Running Lights)	65
Electric Power Steering	62
Fog Lights	64
High Beam	65
High Temperature	63
Key (Immobilizer System)	66
Lights On	64
Low Fuel	62
Low Oil Pressure	60, 303
Low Temperature	63
Low Tire Pressure	64, 235
Maintenance Minder	66, 245
Malfunction Indicator Lamp	60, 304
Passenger Airbag Off	31
Seat Belt Reminder	18, 60
Security System	66
Side Airbag Off	31, 61
SRS	30, 61
TPMS	64, 236
Turn Signal and Hazard Warning	63
VSA Off	67
VSA System	67

CONTINUED

V

Index

Washer Level	65
Infant Restraint	39
Infant Seats	39
Tether Anchorage Point	47
Inflation, Proper Tire	273
Recommended Pressures	274
Inside Mirror	101
Inspection, Tire	275
Installing a Child Seat	42
Instant Fuel Economy	70
Instrument Panel	59
Instrument Panel Brightness	76
Instruments and Controls	57
Interior Lights	107
Ceiling Light	107
Introduction	i
iPod® Error Messages	135, 176

J

Jacking up the Vehicle	285
Jack, Tire	285
Jump Starting	299

K

Keys	78
------------	----

L

Label, Certification	316
Lane Change, Signaling	74
Lap/Shoulder Belt	14, 19
LATCH Anchorage System	43
Lights	
Bulb Replacement	262
Indicator	59
Interior	107
Parking	74
Turn Signal	74
Load Limit	209
LOCK (Ignition Key Position)	80
Locks	
Anti-theft Steering Column	80
Childproof Door	82
Fuel Fill Door	199
Lockout Prevention	82
Power Door	81
Tailgate	88

Low Coolant Level	202
Lower Anchors	43
Lower Glove Box	105
Low Fuel Indicator	62
Low Oil Pressure	
Indicator	60, 303
Lubricant Specifications Chart ...	319
Luggage, Storing (cargo)	208

M

Maintenance	243
Main Items and Sub Items	248
Minder	245
Minder Indicator	66
Owner's Maintenance	
Checks	250
Safety	244
Schedule	251
Malfunction Indicator	
Lamp	60, 304
Manual Transmission	217
Checking Fluid Level	260
Shifting	217
Manual Transmission Fluid	260

Index

Meters, Gauges	68
Methanol in Gasoline	198
Mirrors, Adjusting	101
Modifications	207
Modifying Your Vehicle	207

N

Neutral Gear Position	221
New Vehicle Break-in	198
Normal Shift Speeds	218
NOTICE, Explanation of	i
Numbers, Identification	316

O

Octane Requirement, Gasoline	198
Odometer	70
Odometer, Trip	69
Oil	
Change, How to	254
Change, When to	245
Checking Engine	201
Life, Engine	245

Pressure Indicator	60, 303
Selecting Proper Viscosity Chart	253
Onboard Refueling Vapor Recovery	326
ON (Ignition Key Position)	80
Outside Mirrors	101
Overheating, Engine	301
Owner's Maintenance Checks	250
Oxygenated Fuels	198

P

Paddle Shifters	224
Panel Brightness Control	76
Park Gear Position	220
Parking	229
Parking Brake	102
Parking Brake and Brake System Indicator	60, 305
Parking Lights	74
Parking Over Things that Burn	229, 328
Passenger Airbag Off Indicator	31
PGM-FI System	327

Playing a Disc	122, 149
Playing an iPod®	129, 170
Playing a PC card	158
Playing a USB Flash Memory Device	136, 177
Playing the AM/FM Radio	143
Playing the FM/AM Radio	115
Pollen Filter	268
Power Door Locks	81
Power Socket Location	106
Power Windows	100
Pregnancy, Using Seat Belts	16
Preparing to Drive	215
Proper Seat Belt Usage	14
Protecting Adults and Teens	11
Additional Safety Precautions ...	17
Advice for Pregnant Women	16
Protecting Children	34
General Guidelines	34
Protecting Infants	39
Protecting Larger Children	49
Protecting Small Children	40
Using Child Seats with Tethers	47
Using LATCH	43

CONTINUED

Index

R	
Radiator Overheating	301
Radio/Disc Sound System	143
Radio Theft Protection	191
Readiness Codes	329
Rear Lights, Bulb Replacement	266
Rearview Mirror	101
Rear Window Defogger	76
Rear Window Wiper and Washer	73
Recommended Shift Speeds	218
Refueling	199
Reminder Indicators	60
Remote Audio Controls	189
Remote Transmitter	90
Replacement Information Dust and Pollen Filter	268
Engine Oil and Filter	254
Fuses	306
Light Bulbs	262
Schedule	251
Spark Plugs	318
Tires	276

S		
Wiper Blades	269	
Replacing Seat Belts After a Crash	20	
Reporting Safety Defects (U.S. Vehicles)	334	
Reserve Tank, Engine Coolant	202, 256	
Restraint, Child	34	
Reverse Gear Position	221	
Reverse Lockout	217	
Rotation, Tire	276	
Safety Belts		8, 18
Safety Defects, Reporting (U.S. only)		334
Safety Features		7
Airbags		9, 22
Door Locks		11
Head Restraints		13
Seat Belts		8, 14, 18
Seats & Seat-Backs		11, 12
Safety Labels, Location of		54
Safety Messages		iii

Seat Belts	8, 18
Additional Information	18
Advice for Pregnant Women	16
Automatic Seat Belt Tensioners	20
Cleaning	267
Detachable Anchor	99
Lap/Shoulder Belt	14, 19
Maintenance	20
Reminder Indicator and Beeper	18, 60
System Components	18
Use During Pregnancy	16
Wearing a Lap/Shoulder Belt	14, 19
Seats	93
Seats, Adjusting the	93
Seat Under Box	106
Security System	193
Security System Indicator	66
Sensors Driver's Seat Position Sensor ...	27
Front Passenger's Weight Sensors	27
Impact Sensors	22, 23
Serial Number	316

Index

Service Intervals	245	Speedometer	68	Sun Visor	106
Service Manual (U.S. only)	335	SRS, Additional Information	22	Supplemental Restraint	
Service Station Procedures	199	Additional Safety Precautions ...	33	System	9, 22
Setting the Clock	192	Airbag Service	32	Servicing	32
Shifting the Automatic		Airbag System Components	22	SRS Indicator	30, 61
Transmission	219	How the Side Airbag Off		System Components	22
Shift Lever Position Indicators ...	219	Indicator Works	31	Synthetic Oil	254
Shift Lock Release	223	How the SRS Indicator Works ..	30		
Side Airbags	28	How Your Front Airbags			
How the Side Airbag Off		Work	25		
Indicator Works	31	How Your Side Airbags Work ..	28		
How Your Side Airbags Work ..	28	How Your Side Curtain Airbags			
Side Curtain Airbags	30	Work	30		
How Your Side Curtain Airbags		SRS Indicator	30, 61		
Work	30	START (Ignition Key Position)	80		
Side Marker Lights, Bulb		Starting the Engine	216		
Replacement in	263	In Cold Weather at High			
Signaling Turns	63	Altitude	216		
Snow Tires	278	With a Dead Battery	299		
Spare Tire	284	State Emissions Testing	329		
Inflating	273, 284	Steam Coming from Engine	301		
Specifications	320	Steering Wheel			
Spark Plugs	318	Adjustments	77		
Specifications	318	Anti-theft Column Lock	80		
Speed Control	194	Buttons	189, 194		
Speed Limiter	218, 222	Storing Your Vehicle	281		

T

Tachometer	68
Tailgate	88
Open Indicator	62
Opening the	88
Taillights, Changing Bulbs in	266
Taking Care of the	
Unexpected	283

CONTINUED

Index

Technical Descriptions
DOT Tire Quality Grading (U.S. Vehicles) 321
Emissions Control Systems 326
Three Way Catalytic Converter 328
Tire Labeling 323
Tire Pressure Monitoring System (TPMS) – Required Federal Explanation 324
Temperature Indicator 63
Temporarily Repairing a Flat Tire 291
Tensioners, Seat Belts 20
Tether Anchorage Points 47
Theft Protection, Radio 191
Three Way Catalytic Converter 328
Tilt/Telescopic Steering Wheel ... 77
Time, Setting the 192
Tire Chains 278
Tire, How to Change a Flat 285
Tire Information 323
Tire Labeling 323
Tire Pressure Monitoring System (TPMS) 235, 324

Tires 273
Air Pressure 274
Chains 278
Checking Wear 275
Compact Spare 284
DOT Tire Quality Grading (U.S. Vehicles) 321
Inflation 273
Inspection 275
Labeling 323
Low Tire Pressure Indicator 64, 235
Maintenance 276
Pressure Monitoring System ... 235
Replacing 276
Rotating 276
Snow 278
Specifications 320
Tools, Tire Changing 285
Towing
A Trailer 238
Emergency Wrecker 311
TPMS (Tire Pressure Monitoring System) 235
Indicator 64, 236

Required Federal Explanation 324
Transmission
Checking Fluid Level, Automatic 259
Checking Fluid Level, Manual 260
Fluid Selection 259, 260
Identification Number 316
Shifting the Automatic 219
Shifting the Manual 217
Treadwear 321
Trip Meter 69
Turn Signals 63

U

Unexpected, Taking Care of the 283
Uniform Tire Quality Grading (U.S. only) 321
Unleaded Gasoline 198
Upper Glove Box 105
USB Flash Memory Device Error Messages 142, 183

Used Oil, How to Dispose of 255

V

Vehicle Capacity Load 209
 Vehicle Dimensions 318
 Vehicle Identification Number ... 316
 Vehicle Stability Assist (VSA®),
 aka Electronic Stability
 Control (ESC), System
 VSA OFF Indicator 233
 Vehicle Stability Assist (VSA)
 System 233
 VSA OFF Indicator 67
 VSA OFF Switch 234
 VSA System Indicator 67
 Vehicle Storage 281
 Ventilation 112
 VIN 316
 Viscosity, Oil 253

W

WARNING, Explanation of iii
 Warning Labels, Location of 54

Warranty Coverages (U.S.
 only) 333
 Washer, Windshield
 Checking the Fluid Level 258
 Fluid Level Indicator (Canada
 only) 65
 Operation 73
 Wheels
 Adjusting the Steering 77
 Alignment and Balance 276
 Compact Spare 284
 Wrench, Nut 285
 Windows
 Auto Reverse 101
 Operating the Power 100
 Rear, Defogger 76
 Windshield
 Cleaning 73
 Defroster 113
 Washers 73, 258
 Wipers, Windshield
 Changing Blades 269
 Operation 73
 Rear Windshield Wiper and
 Washer 73
 Worn Tires 275

Wrecker, Emergency Towing 311

Service Information Summary

Gasoline:

Unleaded gasoline, pump octane number of 87 or higher.

Fuel Tank Capacity:

10.6 US gal (40 L)

Recommended Engine Oil:

API Premium grade 5W-20 detergent oil (see page 253).

Oil change capacity (including filter):

3.8 US qt (3.6 L)

Automatic Transmission Fluid:

Honda Genuine ATF-Z1 (automatic transmission fluid) (see page 259).

Manual Transmission Fluid:

Honda Manual Transmission Fluid preferred, or an SAE 10W-30 or 10W-40 motor oil as a temporary replacement (see page 260).

Capacity (including differential):

1.6 US qt (1.5 L)

Brake Fluid:

Honda Heavy Duty Brake Fluid DOT 3 preferred, or a DOT 3 or DOT 4 brake fluid as a temporary replacement (see page 261).

Tire Pressure (measured cold):

Front/Rear:

All models except Sport
32 psi (220 kPa, 2.2 kgf/cm²)

Sport model
33 psi (230 kPa, 2.3 kgf/cm²)

Spare Tire Pressure:

60 psi (420 kPa, 4.2 kgf/cm²)