

2011 CIVIC COUPE

Owner's Manual

(Unlinked)

This document does not contain hyperlinks and may be formatted for printing instead of web use. This is due to changes in content and specifications of the vehicle that happen throughout the model year. This manual will be replaced with a hyperlinked version at the end of the model year.

Owner's Identification

OWNER _____

ADDRESS _____
STREET

_____ CITY STATE/PROVINCE/TERRITORY ZIP CODE/
POSTAL CODE

V. I. N. _____

DELIVERY DATE _____
(Date sold to original retail purchaser)

DEALER NAME _____ DEALER NO. _____

ADDRESS _____
STREET

_____ CITY STATE/PROVINCE/TERRITORY ZIP CODE/
POSTAL CODE

OWNER'S SIGNATURE _____

DEALER'S SIGNATURE _____

This owner's manual should be considered a permanent part of the vehicle and should remain with the vehicle when it is sold.

This owner's manual covers all models of the Civic 2-door. You may find descriptions of equipment and features that are not on your particular model.

Images throughout this owner's manual (including the front cover) represent features and equipment that are available on some, but not all, models. Your particular model may not have some of these features.

The information and specifications included in this publication were in effect at the time of approval for printing. Honda Motor Co., Ltd. reserves the right, however, to discontinue or change specifications or design at any time without notice and without incurring any obligation whatsoever.

POUR CLIENTS CANADIEN
AVIS IMPORTANT: Si vous avez
besoin d'un Manuel du Conducteur
en français, veuillez demander à
votre concessionnaire de
commander le numéro de pièce
33SVAC50

Congratulations! Your selection of a 2011 Honda Civic was a wise investment. It will give you years of driving pleasure.

One of the best ways to enhance the enjoyment of your new vehicle is to read this manual. In it, you will learn how to operate its driving controls and convenience items. Afterwards, keep this owner's manual in your vehicle so you can refer to it at any time.

Several warranties protect your new vehicle. Read the warranty booklet thoroughly so you understand the coverages and are aware of your rights and responsibilities.

Maintaining your vehicle according to the Maintenance Minder™ shown in the instrument panel helps to keep your driving trouble-free while it preserves your investment. When your vehicle needs maintenance, keep in mind that your dealer's staff is specially trained in servicing the many systems unique to your vehicle. Your dealer is dedicated to your satisfaction and will be pleased to answer any questions and concerns.

As you read this manual, you will find information that is preceded by a **NOTICE** symbol. This information is intended to help you avoid damage to your vehicle, other property, or the environment.

Introduction

California Proposition 65 Warning

WARNING: This product contains or emits chemicals known to the State of California to cause cancer and birth defects or other reproductive harm.

Event Data Recorders

This vehicle is equipped with one or more devices commonly referred to as event data recorders. These devices record front seat belt use, front passenger seat occupancy, airbag deployment data, and the failure of any airbag system component. This data belongs to the vehicle owner and may not be accessed by anyone else except as legally required or with the permission of the vehicle owner.

Service Diagnostic Recorders

This vehicle is equipped with service-related devices that record information about powertrain performance. The data can be used to verify emissions law requirements and/or help technicians diagnose and solve service problems. It may also be combined with data from other sources for research purposes, but it remains confidential.

California Perchlorate Contamination Prevention Act

The airbags, seat belt tensioners, and CR type batteries in this vehicle may contain perchlorate materials – special handling may apply. See www.dtsc.ca.gov/hazardouswaste/perchlorate/

Your safety, and the safety of others, is very important. And operating this vehicle safely is an important responsibility.

To help you make informed decisions about safety, we have provided operating procedures and other information on labels and in this manual. This information alerts you to potential hazards that could hurt you or others.

Of course, it is not practical or possible to warn you about all the hazards associated with operating or maintaining your vehicle. You must use your own good judgement.

You will find this important safety information in a variety of forms, including:

- **Safety Labels** – on the vehicle.
- **Safety Messages** – preceded by a safety alert symbol  and one of three signal words: **DANGER**, **WARNING**, or **CAUTION**.
These signal words mean:

 **DANGER**

You **WILL** be **KILLED** or **SERIOUSLY HURT** if you don't follow instructions.

 **WARNING**

You **CAN** be **KILLED** or **SERIOUSLY HURT** if you don't follow instructions.

 **CAUTION**

You **CAN** be **HURT** if you don't follow instructions.

- **Safety Headings** – such as Important Safety Reminders or Important Safety Precautions.
- **Safety Section** – such as Driver and Passenger Safety.
- **Instructions** – how to use this vehicle correctly and safely.

This entire book is filled with important safety information – please read it carefully.

Your Vehicle at a Glance (main controls)	3
Driver and Passenger Safety (seat belts, SRS, and child protection)	5
Instruments and Controls (indicators, gauges, dashboard, and steering column)	55
Features (heating and cooling, audio, steering wheel, security, cruise control, and other convenience items)	117
Before Driving (fuel, vehicle break-in, and cargo loading)	251
Driving (engine and transmission operation)	267
Maintenance (minder, fluid checking, minor services, and vehicle storage)	289
Taking Care of the Unexpected (flat tire, jump starting, overheating, and fuses)	337
Technical Information (vehicle specifications, tires, and emissions controls)	361
Warranty and Customer Relations (U.S. and Canada only) (warranty and contact information)	379
Authorized Manuals (U.S. only) (how to order)	383
Index	I
Service Information Summary (fluid capacities and tire pressures)	last page

Overview of Contents

Contents

A convenient reference to the sections in this manual.

Your Vehicle at a Glance

A quick reference to the main controls in your vehicle.

Driver and Passenger Safety

Important information about the proper use and care of your vehicle's seat belts, an overview of the supplemental restraint system, and valuable information on how to protect children with child restraints.

Instruments and Controls

Explains the purpose of each instrument panel indicator and gauge, and how to use the controls on the dashboard and steering column.

Features

How to operate the heating and air conditioning system, the audio system, and other convenience features.

Before Driving

What gasoline to use, how to break-in your new vehicle, and how to load luggage and other cargo.

Driving

The proper way to start the engine, shift the transmission, and park.

Maintenance

The Maintenance Minder™ shows you when you need to take your vehicle to the dealer for maintenance service. There is also a list of things to check and instructions on how to check them.

Taking Care of the Unexpected

This section covers several problems motorists sometimes experience, and details how to handle them.

Technical Information

ID numbers, dimensions, capacities, and technical information.

Warranty and Customer Relations

(U.S. and Canada only)

A summary of the warranties covering your new vehicle, and how to contact us for any reason. Refer to your warranty manual for detailed information.

Authorized Manuals

(U.S. only)

How to order manuals and other technical literature.

Index

Service Information Summary

A summary of the information you need when you pull up to the fuel pump.

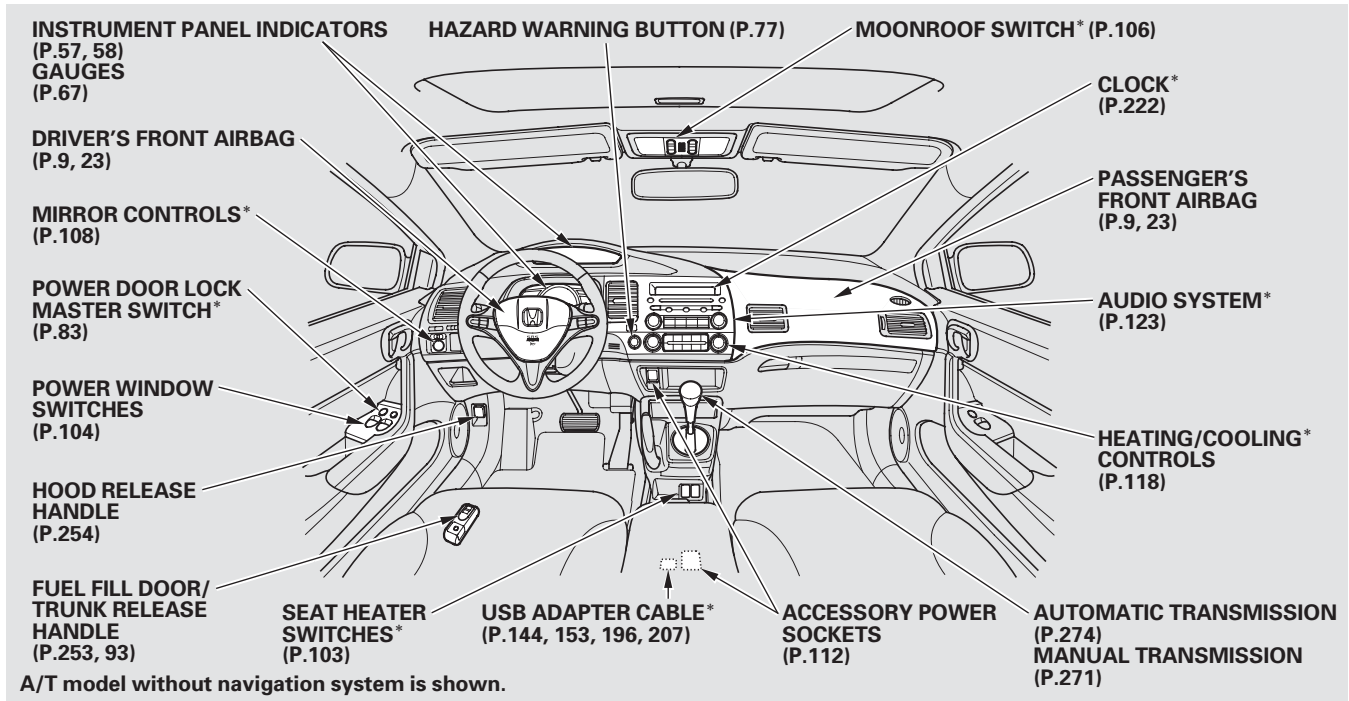

*: If equipped

Your Vehicle at a Glance

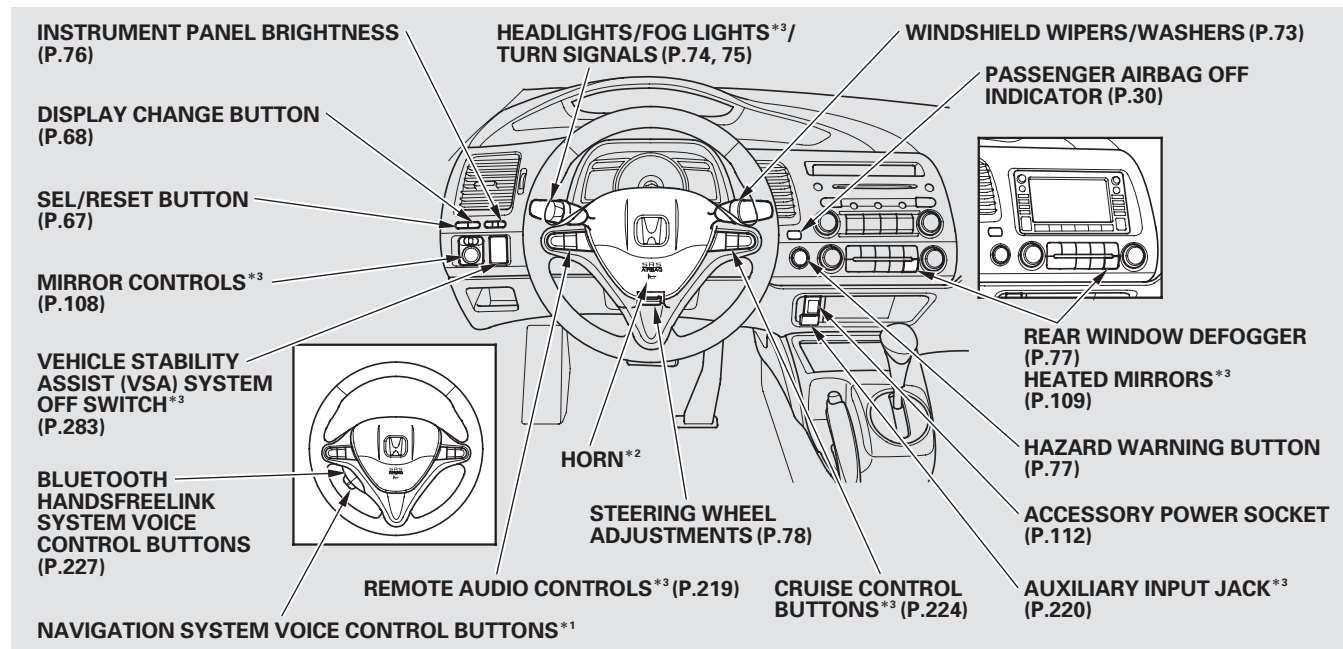

* 1 : Only on vehicles equipped with navigation system, refer to the navigation system manual.

* 2 : To use the horn, press the center pad of the steering wheel.

* 3 : If equipped.

This section gives you important information about how to protect yourself and your passengers. It shows you how to use seat belts. It explains how your airbags work. And it tells you how to properly restrain infants and children in your vehicle.

Important Safety Precautions	6
Your Vehicle's Safety Features.....	7
Protecting Adults and Teens.....	11
1. Close and Lock the Doors	11
2. Adjust the Front Seats	11
3. Adjust the Seat-Backs	12
4. Adjust the Head Restraints ...	13
5. Fasten and Position the Seat Belts	14
6. Maintain a Proper Sitting Position	15
Advice for Pregnant Women.....	16
Additional Safety Precautions....	16

Additional Information About Your Seat Belts	18
Seat Belt System Components...	18
Lap/Shoulder Belt	19
Automatic Seat Belt Tensioners.....	19
Seat Belt Maintenance	20
Additional Information About Your Airbags	21
Airbag System Components.....	21
How Your Front Airbags Work.....	23
How Your Side Airbags Work....	27
How Your Side Curtain Airbags Work.....	29
How the SRS Indicator Works... ..	29
How the Side Airbag Off Indicator Works	30
How the Passenger Airbag Off Indicator Works	30
Airbag Service.....	31
Additional Safety Precautions....	32
Protecting Children – General Guidelines.....	33
All Children Must Be Restrained	33

All Children Should Sit in a Back Seat	34
The Passenger's Front Airbag Can Pose Serious Risks	34
If a Child Must Drive with Several Children	36
If a Child Requires Close Attention	36
Additional Safety Precautions....	36
Protecting Infants and Small Children	38
Protecting Infants	38
Protecting Small Children	39
Selecting a Child Seat.....	40
Installing a Child Seat	41
With LATCH	42
With a Lap/Shoulder Belt	44
With a Tether	46
Protecting Larger Children.....	48
Checking Seat Belt Fit	48
Using a Booster Seat	49
When Can a Larger Child Sit in Front.....	50
Additional Safety Precautions....	51
Carbon Monoxide Hazard	52
Safety Labels	53

Important Safety Precautions

You'll find many safety recommendations throughout this section, and throughout this manual. The recommendations on this page are the ones we consider to be the most important.

Always Wear Your Seat Belt

A seat belt is your best protection in all types of collisions. Airbags are designed to supplement seat belts, not replace them. So even though your vehicle is equipped with airbags, make sure you and your passengers always wear your seat belts, and wear them properly (see page 14).

Restrain All Children

Children age 12 and under should ride properly restrained in a back seat, not the front seat. Infants and small children should be restrained in a child seat. Larger children should use a booster seat and a lap/shoulder belt until they can use the belt properly without a booster seat

(see pages 33 – 51).

Be Aware of Airbag Hazards

While airbags can save lives, they can cause serious or fatal injuries to occupants who sit too close to them, or are not properly restrained.

Infants, young children, and short adults are at the greatest risk. Be sure to follow all instructions and warnings in this manual.

Don't Drink and Drive

Alcohol and driving don't mix. Even one drink can reduce your ability to respond to changing conditions, and your reaction time gets worse with every additional drink. So don't drink and drive, and don't let your friends drink and drive, either.

Pay Appropriate Attention to the Task of Driving Safely

Engaging in mobile phone conversation or other activities that keep you from paying close attention

to the road, other vehicles and pedestrians could lead to a crash. Remember, situations can change quickly, and only you can decide when it is safe to divert attention away from driving.

Control Your Speed

Excessive speed is a major factor in crash injuries and deaths. Generally, the higher the speed, the greater the risk, but serious injuries can also occur at lower speeds. Never drive faster than is safe for current conditions, regardless of the maximum speed posted.

Keep Your Vehicle in Safe Condition

Having a tire blowout or a mechanical failure can be extremely hazardous. To reduce the possibility of such problems, check your tire pressures and condition frequently, and perform all regularly scheduled maintenance (see page 291).

Your Vehicle's Safety Features

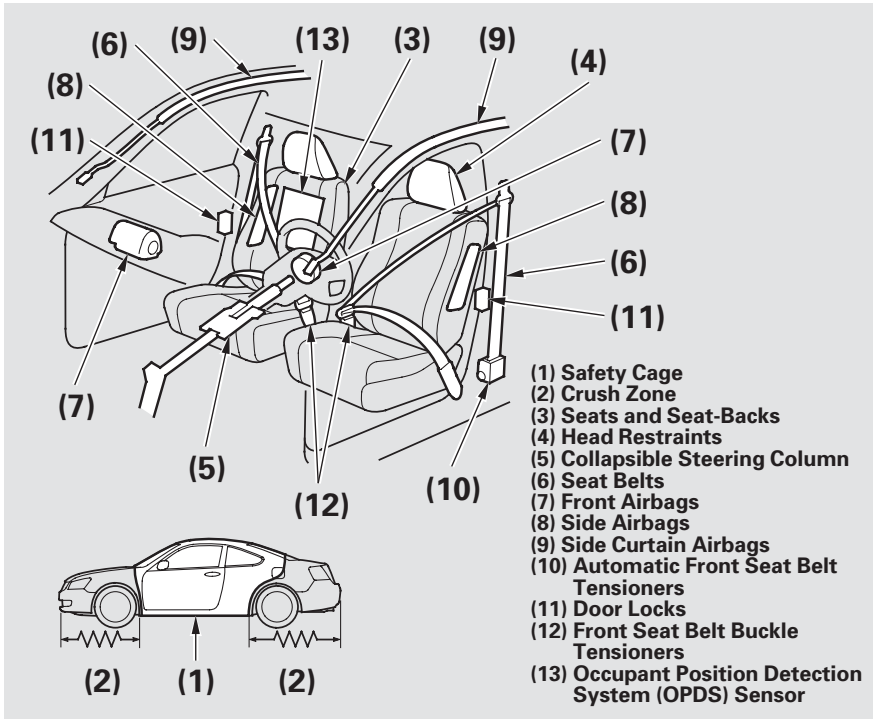

Your vehicle is equipped with many features that work together to protect you and your passengers during a crash.

Some features do not require any action on your part. These include a strong steel framework that forms a safety cage around the passenger compartment, front and rear crush zones, a collapsible steering column, and tensioners that tighten the front seat belts in a crash.

However, you and your passengers can't take full advantage of these features unless you remain sitting in the correct position and ***always wear your seat belts***. In fact, some safety features can contribute to injuries if they are not used properly.

The following pages explain how you can take an active role in protecting yourself and your passengers.

Your Vehicle's Safety Features

Seat Belts

Your vehicle is equipped with seat belts in all seating positions.

Your seat belt system also includes an indicator on the instrument panel and a beeper to remind you and your passengers to fasten your seat belts.

Why Wear Seat Belts

Seat belts are the single most effective safety device for adults and larger children. (Infants and smaller children must be properly restrained in child seats.)

Not wearing a seat belt properly increases the chance of serious injury or death in a crash, even though your vehicle has airbags.

In addition, most states and all Canadian provinces and territories require you to wear seat belts.

⚠ WARNING

Not wearing a seat belt properly increases the chance of serious injury or death in a crash, even though your vehicle has airbags.

Be sure you and your passengers always wear seat belts and wear them properly.

When properly worn, seat belts:

- Keep you connected to the vehicle so you can take advantage of the vehicle's built-in safety features.
- Help protect you in almost every type of crash, including:
 - frontal impacts
 - side impacts
 - rear impacts
 - rollovers

- Help keep you from being thrown against the inside of the vehicle and against other occupants.
- Keep you from being thrown out of the vehicle.
- Help keep you in a good position should the airbags ever deploy. A good position reduces the risk of injury from an inflating airbag and allows you to get the best advantage from the airbag.

Of course, seat belts cannot completely protect you in every crash. But in most cases, seat belts can reduce your risk of serious injury.

What You Should Do:

Always wear your seat belt, and make sure you wear it properly.

Airbags

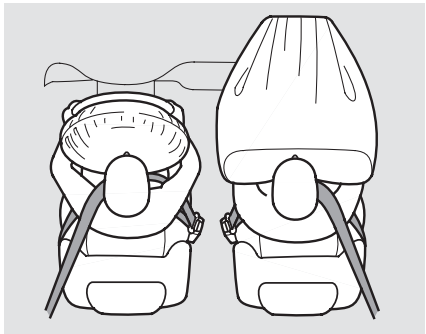

Your vehicle has a supplemental restraint system (SRS) with front airbags to help protect the heads and chests of the driver and a front seat passenger during a moderate to severe frontal collision (see page 23 for more information on how your front airbags work).

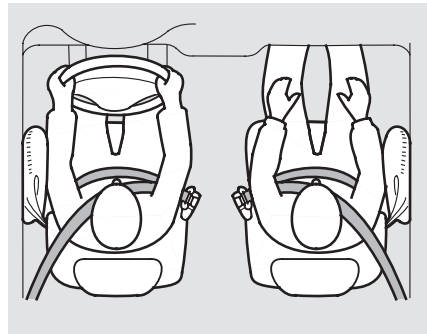

Your vehicle also has side airbags to help protect the upper torso of the driver or a front seat passenger during a moderate to severe side impact (see page 27 for more information on how your side airbags work).

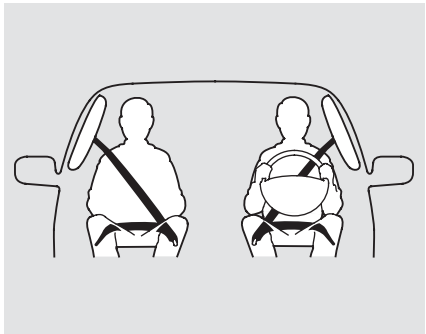

In addition, your vehicle has side curtain airbags to help protect the heads of the driver, front passenger, and passengers in the outer rear seating positions during a moderate to severe side impact (see page 29 for more information on how your side curtain airbags work).

CONTINUED

Your Vehicle's Safety Features

The most important things you need to know about your airbags are:

- ***Airbags do not replace seat belts.*** They are designed to supplement the seat belts.
- ***Airbags offer no protection in rear collisions, or minor frontal or side collisions.***
- ***Airbags can pose hazards.*** To do their job, airbags must inflate with tremendous force. So while airbags help save lives, they can cause minor injuries or more serious or even fatal injuries if occupants are not properly restrained or sitting properly.

What you should do: Always wear your seat belt properly, and sit upright and as far back from the steering wheel as possible while allowing full control of the vehicle. A front passenger should move their seat as far back from the dashboard as possible.

The rest of this section gives more detailed information about how you can maximize your safety.

Remember, however, that no safety system can prevent all injuries or deaths that can occur in a severe crash, even when seat belts are properly worn and the airbags deploy.

Introduction

The following pages provide instructions on how to properly protect the driver, adult passengers, and teenage children who are large enough and mature enough to drive or ride in the front.

See pages 33 – 37 for important guidelines on how to properly protect infants, small children, and larger children who ride in your vehicle.

1. Close and Lock the Doors

After everyone has entered the vehicle, be sure the doors are closed and locked.



Your vehicle has a door-open indicator on the instrument panel to indicate when either door is not tightly closed.

Locking the doors reduces the chance of someone being thrown out of the vehicle during a crash, and it helps prevent passengers from accidentally opening a door and falling out.

Locking the doors also helps prevent an outsider from unexpectedly opening a door when you come to a stop.

See page 82 for how to lock the doors, and page 65 for how the door-open indicator works.

Some models have the auto door locking/unlocking feature. For more information, see page 84 .

2. Adjust the Front Seats

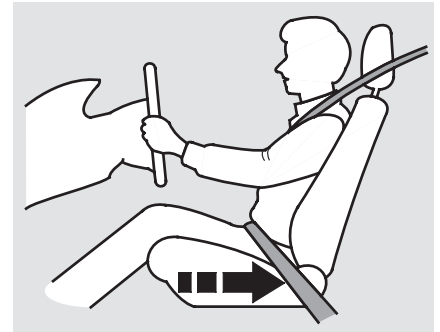

Adjust the driver's seat as far to the rear as possible while allowing you to maintain full control of the vehicle. Have a front passenger adjust their seat as far to the rear as possible.

CONTINUED

Protecting Adults and Teens

If you sit too close to the steering wheel or dashboard, you can be seriously injured by an inflating front airbag, or by striking the steering wheel or dashboard.

The National Highway Traffic Safety Administration and Transport Canada recommend that drivers allow at least 10 inches (25 cm) between the center of the steering wheel and the chest. In addition to adjusting the seat, you can adjust the steering wheel up and down, and in and out (see page 78).

If you cannot get far enough away from the steering wheel and still reach the controls, we recommend that you investigate whether some type of adaptive equipment may help.

⚠ WARNING

Sitting too close to a front airbag can result in serious injury or death if the front airbags inflate.

Always sit as far back from the front airbags as possible.

Once your seat is adjusted correctly, rock it back and forth to make sure the seat is locked in position.

See page 95 for how to adjust the front seats.

3. Adjust the Seat-Backs

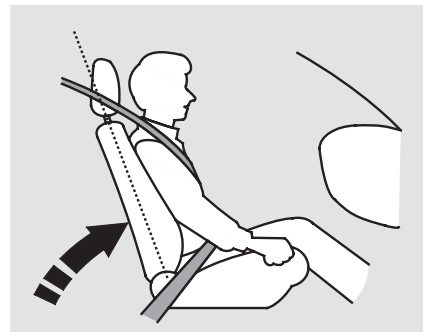

Adjust the driver's seat-back to a comfortable, upright position, leaving ample space between your chest and the airbag cover in the center of the steering wheel.

Passengers with adjustable seat-backs should also adjust their seat-back to a comfortable, upright position.

⚠ WARNING

Reclining the seat-back too far can result in serious injury or death in a crash.

Adjust the seat-back to an upright position, and sit well back in the seat.

Reclining a seat-back so that the shoulder part of the belt no longer rests against the occupant's chest reduces the protective capability of the belt. It also increases the chance of sliding under the belt in a crash and being seriously injured. The farther a seat-back is reclined, the greater the risk of injury.

See page 95 for how to adjust the seat-backs.

4. Adjust the Head Restraints

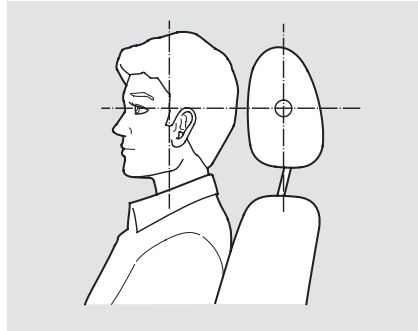

Adjust the driver's head restraint so the center of the back of your head rests against the center of the restraint.

Have passengers adjust their head restraints properly as well. Taller persons should adjust their restraint as high as possible.

⚠ WARNING

Improperly positioning head restraints reduces their effectiveness and you can be seriously injured in a crash.

Make sure head restraints are in place and positioned properly before driving.

Properly adjusted head restraints will help protect occupants from whiplash and other crash injuries.

See page 98 for how to adjust the head restraints and how the driver's and front passenger's active head restraints work.

Protecting Adults and Teens

5. Fasten and Position the Seat Belts

Insert the latch plate into the buckle, then tug on the belt to make sure the belt is securely latched. Check that the belt is not twisted, because a twisted belt can cause serious injuries in a crash.



Position the lap part of the belt as low as possible across your hips, then pull up on the shoulder part of the belt so the lap part fits snugly. This lets your strong pelvic bones take the force of a crash and reduces the chance of internal injuries.

If necessary, pull up on the belt again to remove any slack, then check that the belt rests across the center of your chest and over your shoulder.

This spreads the forces of a crash over the strongest bones in your upper body.

⚠ WARNING

Improperly positioning the seat belts can cause serious injury or death in a crash.

Make sure all seat belts are properly positioned before driving.

Never place the shoulder portion of a lap/shoulder belt under your arm or behind your back. This could cause very serious injuries in a crash.

If a seat belt does not seem to work properly, it may not protect the occupant in a crash.

No one should sit in a seat with an inoperative seat belt. Using a seat belt that is not working properly can result in serious injury or death. Have your dealer check the belt as soon as possible.

See page 18 for additional information about your seat belts and how to take care of them.

6. Maintain a Proper Sitting Position

After all occupants have adjusted their seats and head restraints, and put on their seat belts, it is very important that they continue to sit upright, well back in their seats, with their feet on the floor, until the vehicle is safely parked and the engine is off.

Sitting improperly can increase the chance of injury during a crash. For example, if an occupant slouches, lies down, turns sideways, sits forward, leans forward or sideways, or puts one or both feet up, the chance of injury during a crash is greatly increased.

In addition, an occupant who is out of position in the front seat can be seriously or fatally injured in a crash by striking interior parts of the vehicle or being struck by an inflating front airbag.

⚠ WARNING

Sitting improperly or out of position can result in serious injury or death in a crash.

Always sit upright, well back in the seat, with your feet on the floor.

Protecting Adults and Teens

Advice for Pregnant Women



If you are pregnant, the best way to protect yourself and your unborn child when driving or riding in a vehicle is to always wear a seat belt, and keep the lap part of the belt as low as possible across the hips.

When driving, remember to sit upright and adjust the seat as far back as possible while allowing full control of the vehicle. When riding as a front passenger, adjust the seat as far back as possible.

This will reduce the risk of injuries to both you and your unborn child that can be caused by a crash or an inflating front airbag.

Each time you have a checkup, ask your doctor if it's okay for you to drive.

Additional Safety Precautions

- ***Two people should never use the same seat belt.*** If they do, they could be very seriously injured in a crash.
- ***Do not put any accessories on seat belts.*** Devices intended to improve occupant comfort or reposition the shoulder part of a seat belt can reduce the protective capability of the belt and increase the chance of serious injury in a crash.
- ***Do not place hard or sharp objects between yourself and a front airbag.*** Carrying hard or sharp objects on your lap, or driving with a pipe or other sharp object in your mouth, can result in injuries if your front airbag inflates.

- **Keep your hands and arms away from the airbag covers.** If your hands or arms are close to an airbag cover, they could be injured if the airbag inflates.
 - **Do not attach or place objects on the front airbag covers.** Objects on the covers marked “SRS AIRBAG” could interfere with the proper operation of the airbags or be propelled inside the vehicle and hurt someone if the airbags inflate.
 - **Do not attach hard objects on or near a door.** If a side airbag or a side curtain airbag inflates, a cup holder or other hard object attached on or near the door could be propelled inside the vehicle and hurt someone.
- **Do not cover or replace front seat-back covers without consulting your dealer.** Improperly replacing or covering front seat-back covers can prevent your side airbags from inflating during a side impact.
 - **Never let passengers ride on top of a folded-down rear seat.** If they do, they could be very seriously injured in a crash.

Additional Information About Your Seat Belts

Seat Belt System Components

Your seat belt system includes lap/shoulder belts in all seating positions. The front seat belts are also equipped with automatic seat belt tensioners.



The seat belt system includes an indicator on the instrument panel and a beeper to remind you and your passengers to fasten your seat belts.

This system monitors the front seat belts. If you turn the ignition switch to the ON (II) position before your seat belt is fastened, the beeper will sound and the indicator will flash. If your seat belt is not fastened before the beeper stops, the indicator will stop flashing but remain on.

If a front passenger does not fasten their seat belt, the indicator will come on about 6 seconds after the ignition switch is turned to the ON (II) position.

If either the driver or a front passenger does not fasten their seat belt while driving, the beeper will sound and the indicator will flash again at regular intervals.

When no one is sitting in the front passenger's seat, or a child or small adult is riding there, the indicator should not come on and the beeper should not sound.

If the indicator comes on or the beeper sounds when the driver's seat belt is latched and there is no front seat passenger and no items on the front seat, something may be interfering with the monitoring system. Look for and remove:

- Any items under the front passenger's seat.
- Any object(s) hanging on the seat or in the seat-back pocket.
- Any object(s) touching the rear of the seat-back.

If no obstructions are found, have your vehicle checked by a dealer.

Additional Information About Your Seat Belts

Lap/Shoulder Belt

The lap and shoulder belt goes over your shoulder, across your chest, and across your hips.

To fasten the belt, insert the latch plate into the buckle, then tug on the belt to make sure the buckle is latched (see page 14 for how to properly position the belt).

To unlock the belt, press the red **PRESS** button on the buckle. Guide the belt across your body so that it retracts completely. After exiting the vehicle, be sure the belt is out of the way and will not get closed in the door.

All seat belts have an emergency locking retractor. In normal driving, the retractor lets you move freely in your seat while it keeps some tension on the belt. During a collision or sudden stop, the retractor automatically locks the belt to help restrain your body.

In addition, the lap/shoulder belts in all seating positions except the driver's have a lockable retractor that must be activated to secure a child seat (see page 44).

If the shoulder part of the belt is pulled all the way out, the lockable retractor will activate. The belt will retract, but it will not allow the passenger to move freely.

To deactivate the lockable retractor, unlatch the buckle and let the seat belt fully retract. To refasten the seat belt, pull it out only as far as needed.

Automatic Seat Belt Tensioners

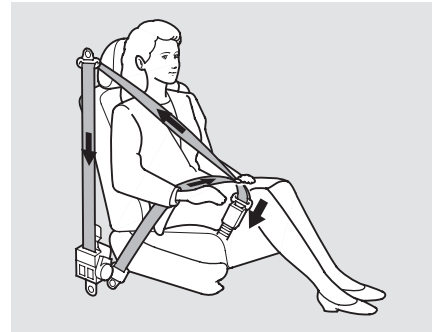

For added protection, the front seat belts are equipped with automatic seat belt tensioners. When activated, the tensioners immediately tighten the belts to help hold the driver and a front passenger in position.

CONTINUED

Additional Information About Your Seat Belts

The tensioners can be activated during a collision in which the front airbags *do not deploy*. In this case, the airbags would not be needed, but the additional restraint could be helpful.

If the tensioner is activated, the SRS indicator comes on and the tensioner must be replaced.

Seat Belt Maintenance

For safety, you should check the condition of your seat belts regularly.

Pull each belt out fully, and look for frays, cuts, burns, and wear. Check that the latches work smoothly and the belts retract easily. If a belt does not retract easily, cleaning the belt may correct the problem (see page 319). Any belt that is not in good condition or working properly will not provide good protection and should be replaced as soon as possible.

Honda provides a limited warranty on seat belts. See your *Honda Warranty Information* booklet for details.

If a seat belt is worn during a crash, it must be replaced by your dealer. A belt that has been worn during a crash may not provide the same level of protection in a subsequent crash.

The dealer should also inspect the anchors for damage and replace them if needed. If the automatic seat belt tensioners activate during a crash, they must be replaced.

WARNING

Not checking or maintaining seat belts can result in serious injury or death if the seat belts do not work properly when needed.

Check your seat belts regularly and have any problem corrected as soon as possible.

Additional Information About Your Airbags

Airbag System Components

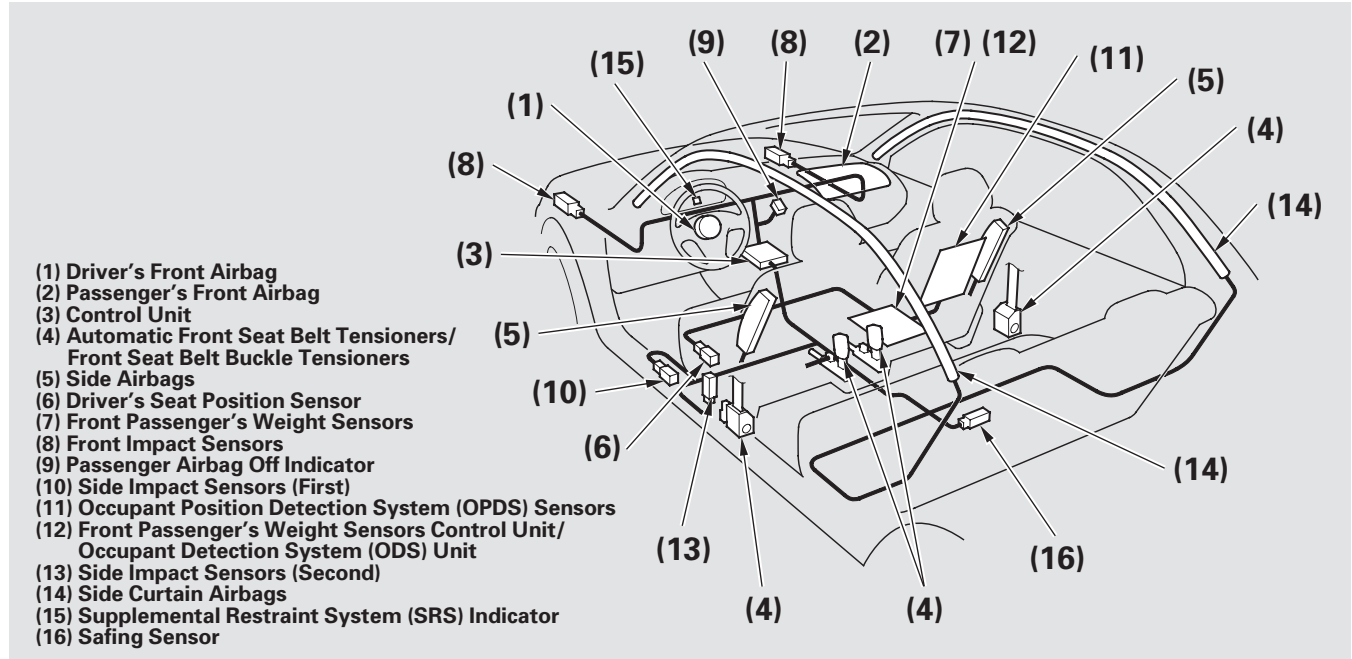

CONTINUED

Additional Information About Your Airbags

Your airbag system includes:

- Two SRS (supplemental restraint system) front airbags. The driver's airbag is stored in the center of the steering wheel; the front passenger's airbag is stored in the dashboard. Both are marked "SRS AIRBAG" (see page 23).
- Two side airbags, one for the driver and one for a front passenger. The airbags are stored in the outer edges of the seat-backs. Both are marked "SIDE AIRBAG" (see page 27).
- Two side curtain airbags, one for each side of the vehicle. The airbags are stored in the ceiling, above the side windows. The front and rear pillars are marked "SIDE CURTAIN AIRBAG" (see page 29).
- Automatic front seat belt tensioners (see page 19).
- Sensors that can detect a moderate to severe front impact or side impact.
- Sensors that can detect whether a child is in the passenger's side airbag path and signal the control unit to turn the airbag off (see page 28).
- Sensors that can detect whether the driver's seat belt and the front passenger's seat belt are latched or unlatched (see page 18).
- A driver's seat position sensor that monitors the distance of the seat from the front airbag. If the seat is too far forward, the airbag will inflate with less force (see page 26).
- Weight sensors that monitor the weight on the front passenger's seat. If the weight is about 65 lbs (29 kg) or less (the weight of an infant or small child), the passenger's front airbag will be turned off (see page 26).
- A sophisticated electronic system that continually monitors and records information about the sensors, the control unit, the airbag activators, the seat belt tensioners, and driver and front passenger seat belt use when the ignition switch is in the ON (II) position.
- An indicator on the instrument panel that alerts you to a possible problem with your airbag system components (see page 29).

Additional Information About Your Airbags

- An indicator on the instrument panel that alerts you that the passenger's side airbag has been turned off (see page 30).
- An indicator on the dashboard that alerts you that the passenger's front airbag has been turned off (see page 30).
- Emergency backup power in case your vehicle's electrical system is disconnected in a crash.

How Your Front Airbags Work

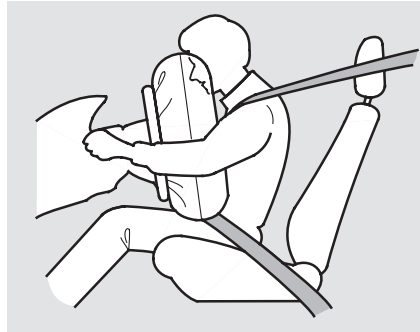

If you ever have a moderate to severe frontal collision, sensors will detect the vehicle's rapid deceleration.

If the rate of deceleration is high enough, the control unit will inflate the driver's and front passenger's airbags, at the time and with the force needed.

During a frontal crash, your seat belt restrains your lower body and torso, and the front airbag helps protect your head and chest.

Although both airbags normally inflate within split second of each other, it is possible for only one airbag to deploy.

This can happen if the severity of a collision is at the margin, or threshold, that determines whether or not the airbags will deploy. In such cases, the seat belt will provide sufficient protection, and the supplemental protection offered by the airbag would be minimal.

CONTINUED

Additional Information About Your Airbags

Only the driver's airbag will deploy if there is no passenger in the front seat, or if the advanced airbag system has turned the passenger's airbag off (see page 26).

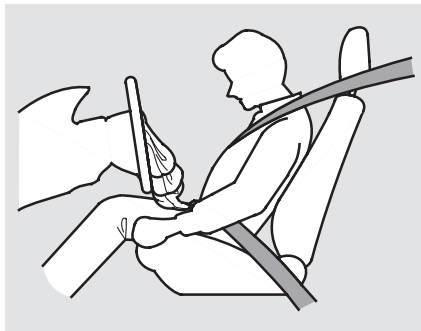

After inflating, the front airbags immediately deflate, so they won't interfere with the driver's visibility, or the ability to steer or operate other controls.

The total time for inflation and deflation is one-tenth of a second, so fast that most occupants are not aware that the airbags deployed until they see them lying in their laps.

After a crash, you may see what looks like smoke. This is actually powder from the airbag's surface. Although the powder is not harmful, people with respiratory problems may experience some temporary discomfort. If this occurs, get out of the vehicle as soon as it is safe to do so.

Dual-Stage, Multiple-Threshold Front Airbags (SRS)

Your vehicle is equipped with dual-stage, multiple-threshold front airbags (SRS). During a frontal crash severe enough to cause one or both front airbags to deploy, the airbags can inflate at different rates, depending on the severity of the crash, whether or not the seat belts are latched, and/or other factors. Front airbags are designed to supplement the seat belts to help reduce the likelihood of head and chest injuries in frontal crashes.

Advanced Airbags

Your front airbags are also advanced airbags. The main purpose of this feature is to help prevent airbag-caused injuries to short drivers and children or small-statured adults who ride in front.

For both advanced airbags to work properly:

- Occupants must sit upright and wear their seat belts properly.
- Do not spill any liquids on or under the seats, cover the sensors, or put any objects or metal items under the front seats.
- Objects placed or pushed under the front passenger's seat may cause the sensor to malfunction, increasing the risk of injury in a crash.

Failure to follow these instructions could damage the sensors or prevent them from working properly.

CONTINUED

Additional Information About Your Airbags

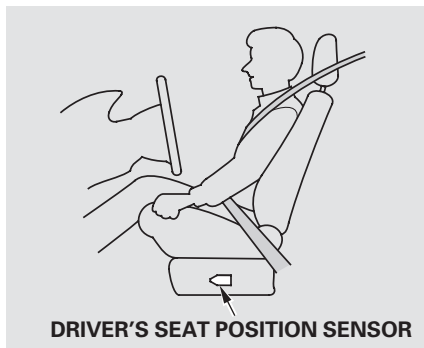

The driver's advanced front airbag system includes a seat position sensor under the seat. If the seat is too far forward, the airbag will inflate with less force, regardless of the severity of the impact.

If there is a problem with the sensor, the SRS indicator will come on, and the airbag will inflate in the normal manner regardless of the driver's seating position.

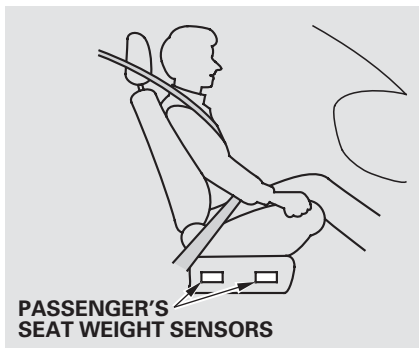

The passenger's advanced front airbag system has weight sensors under the seat. Although Honda does not encourage carrying an infant or small child in front, if the sensors detect the weight of an infant or small child (up to about 65 lbs or 29 kg), the system will automatically turn the passenger's front airbag off.

Be aware that objects placed on the passenger's seat can also cause the airbag to be turned off.

When the passenger airbag gets turned off by the weight sensors, a "passenger airbag off" indicator in the center of the dashboard comes on (see page 30).

If the weight sensors detect there is no passenger in the front seat, the airbag is automatically turned off. However, the passenger airbag off indicator in this situation will not come on.

Additional Information About Your Airbags

To ensure that the passenger's advanced front airbag system will work properly, ***do not do anything that would increase or decrease the weight on the front passenger's seat.*** This includes:

- A rear passenger pushing or pulling on the back of the front passenger's seat.
- Moving the front seat or seat-back forcibly back against cargo on the seat or floor behind it.
- Moving the front seat or seat-back forcibly back against the folded rear seat.
- Hanging heavy items on the front passenger seat, or placing heavy items in the seat-back pocket.

- Back seat passengers should not wedge objects or intentionally force their feet under the front passenger seat.
- If your vehicle is equipped with the floor mats, make sure the floor mat behind the front passenger's seat is hooked to the floor mat anchor (see page 320). If it is not, the mat may interfere with the proper operation of the sensors and operation of the seat.

How Your Side Airbags Work

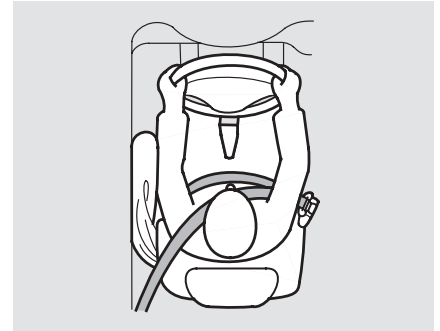

If you ever have a moderate to severe side impact, sensors will detect rapid acceleration and signal the control unit to instantly inflate either the driver's or the passenger's side airbag.

CONTINUED

Additional Information About Your Airbags

Only one airbag will deploy during a side impact. If the impact is on the passenger's side, the passenger's side airbag will deploy even if there is no passenger.

To get the best protection from the side airbags, front seat occupants should wear their seat belts and sit upright and well back in their seats.

Side Airbag Cutoff System

Your vehicle has a side airbag cutoff system designed primarily to protect a child riding in the front passenger's seat.

Although Honda does not encourage children to ride in front, if position sensors detect a child has leaned into the side airbag's deployment path, the airbag will shut off.

The side airbag may also shut off if a short adult leans sideways, or a larger adult slouches and leans sideways into the airbag's deployment path.

Objects placed on the front passenger seat can also cause the side airbag to be shut off.

If the side airbag off indicator comes on (see page 30), have the passenger sit upright. Once the passenger is out of the airbag's deployment path, the system will turn the airbag back on, and the indicator will go out.

There will be some delay between the moment the passenger moves into or out of the airbag deployment path and when the indicator comes on or goes off.

A front seat passenger should not use a cushion or another object as a backrest. It may prevent the cutoff system from working properly.

How Your Side Curtain Airbags Work

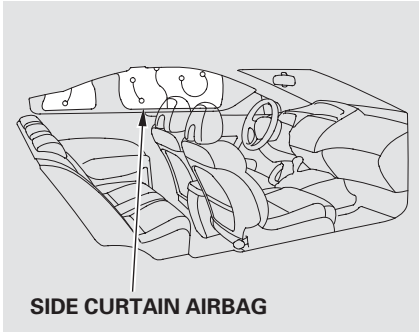

In a moderate to severe side impact, sensors will detect rapid acceleration and signal the control unit to instantly inflate the side curtain airbag.

If the impact is on the passenger's side, the passenger's side curtain airbag will inflate even if there are no occupants on that side of the vehicle.

To get the best protection from the side curtain airbags, occupants should wear their seat belts and sit upright and well back in their seats.



How the SRS Indicator Works

The SRS indicator alerts you to a potential problem with your airbag system components.

When you turn the ignition switch to the ON (II) position, this indicator comes on briefly then goes off. This tells you the system is working properly.

If the indicator comes on at any other time, or does not come on at all, you should have the system checked by your dealer. For example:

- If the SRS indicator does not come on after you turn the ignition switch to the ON (II) position.
- If the indicator stays on after the engine starts.

CONTINUED

Additional Information About Your Airbags

- If the indicator comes on or flashes on and off while you drive.

If you see any of these indications, the airbag system components may not work properly when you need them.

⚠ WARNING

Ignoring the SRS indicator can result in serious injury or death if the airbag systems or tensioners do not work properly.

Have your vehicle checked by a dealer as soon as possible if the SRS indicator alerts you to a possible problem.

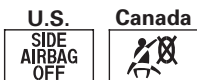

Canada



How the Side Airbag Off Indicator Works

This indicator alerts you that the passenger's side airbag has been automatically shut off. It does *not* mean there is a problem with your side airbags.

When you turn the ignition switch to the ON (II) position, the indicator should come on briefly and then go off (see page 60). If it doesn't come on, stays on, or comes on while driving without a passenger in the front seat, have the system checked.

How the Passenger Airbag Off Indicator Works

PASSENGER AIRBAG OFF INDICATOR

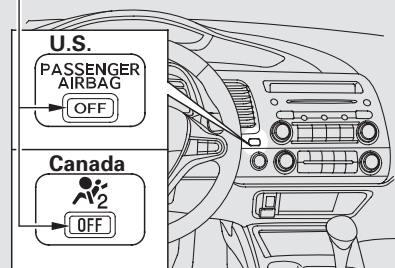

This indicator alerts you that the passenger's front airbag has been shut off because weight sensors detect about 65 lbs (29 kg) or less (the weight of an infant or small child) on the front passenger's seat. It does *not mean* there is a problem with the airbag.

Be aware that objects placed on the front seat can cause the indicator to come on.

If no weight is detected on the front seat, the airbag will be automatically shut off. However, the indicator will not come on.

The passenger airbag off indicator may come on and off repeatedly if the total weight on the seat is near the airbag cutoff threshold.

If an adult or teenage passenger is riding in front, move the seat as far to the rear as possible, and have the passenger sit upright and wear the seat belt properly.

If the indicator comes on with no front seat passenger and no objects on the seat, or with an adult riding there, something may be interfering with the weight sensors. Look for and remove:

- Any items under the front passenger's seat.
- Any object(s) hanging on the seat or in the seat-back pocket.
- Any object(s) touching the rear of the seat-back.

If no obstructions are found, have your vehicle checked by a dealer as soon as possible.

Airbag Service

Your airbag systems are virtually maintenance free, and there are no parts you can safely service. However, you must have your vehicle serviced if:

- ***An airbag ever inflates.*** Any airbag that has deployed must be replaced along with the control unit and other related parts. Any seat belt tensioner that activates must also be replaced.

Do not try to remove or replace any airbag by yourself. This must be done by an authorized dealer or a knowledgeable body shop.

CONTINUED

Additional Information About Your Airbags

- ***The SRS indicator alerts you to a problem.*** Take your vehicle to an authorized dealer as soon as possible. If you ignore this indication, your airbags may not operate properly.
- ***If your vehicle has a moderate to severe impact.*** Even if your airbags do not inflate, your dealer should inspect the driver's seat position sensor, the front passenger's weight sensors, the front seat belt tensioners, and all seat belts and their anchors worn during a crash to make sure they are operating properly.

Additional Safety Precautions

- ***Do not attempt to deactivate your airbags.*** Together, airbags and seat belts provide the best protection.
- ***Do not tamper with airbag components or wiring for any reason.*** Tampering could cause the airbags to deploy, possibly causing very serious injury.
- ***Do not expose the front passenger's seat-back to liquid.*** If water or another liquid soaks into the seat-back, it can prevent the side airbag cutoff system from working properly.

- ***Do not remove or modify a front seat without consulting your dealer.*** This could make the driver's seat position sensor or the front passenger's weight sensors ineffective. If it is necessary to remove or modify a front seat to accommodate a person with disabilities, first contact Honda Automobile Customer Service at (800) 999-1009 in the US, or Honda Customer Relations at 1-888-9-HONDA-9 in Canada.

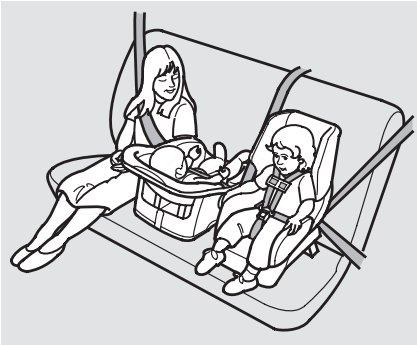

Children depend on adults to protect them. However, despite their best intentions, many adults do not know how to *properly* protect child passengers.

If you have children, or ever need to drive with a child in your vehicle, be sure to read this section. It begins with important general guidelines, then presents special information for infants, small children, and larger children.

All Children Must Be Restrained

Each year, many children are injured or killed in vehicle crashes because they are either unrestrained or not properly restrained. In fact, traffic collisions are the number one cause of death of children age 12 and under.

To reduce the number of child deaths and injuries, every state, Canadian province and territory requires that infants and children be properly restrained when they ride in a vehicle.

Infants and small children must be restrained in an approved child seat that is properly secured to the vehicle (see pages 38 – 47).

⚠ WARNING

Children who are unrestrained or improperly restrained can be seriously injured or killed in a crash.

Any child too small for a seat belt should be properly restrained in a child seat. A larger child should be properly restrained with a seat belt and use a booster seat if necessary.

Larger children must be restrained with a lap/shoulder belt and ride on a booster seat until the seat belt fits them properly (see pages 48 – 51).

Protecting Children – General Guidelines

All Children Should Sit in a Back Seat

According to crash statistics, children of all ages and sizes are safer when they are restrained in a back seat.

The National Highway Traffic Safety Administration and Transport Canada recommend that all children age 12 and under be properly restrained in a back seat. Some states have laws restricting where children may ride.

Children who ride in back are less likely to be injured by striking interior vehicle parts during a collision or hard braking. Also, children cannot be injured by an inflating front airbag when they ride in the back.

The Passenger's Front Airbag Can Pose Serious Risks

Front airbags have been designed to help protect adults in a moderate to severe frontal collision. To do this, the passenger's front airbag is quite large, and it can inflate with enough force to cause very serious injuries.

Even though your vehicle has an advanced front airbag system that automatically turns the passenger's front airbag off under certain circumstances (see page 30), please follow these guidelines:

Infants

Never put a rear-facing child seat in the front seat of a vehicle equipped with a passenger's front airbag. If the airbag inflates, it can hit the back of the child seat with enough force to kill or very seriously injure an infant.

Small Children

Placing a forward-facing child seat in the front seat of a vehicle equipped with a passenger's front airbag can be hazardous. If the vehicle seat is too far forward, or the child's head is thrown forward during a collision, an inflating front airbag can strike the child with enough force to kill or very seriously injure a small child.

Larger Children

Children who have outgrown child seats are also at risk of being injured or killed by an inflating passenger's front airbag. Whenever possible, larger children should sit in the back seat, on a booster seat if needed, and be properly restrained with a seat belt (see page 48 for important information about protecting larger children).

To remind you of the passenger's front airbag hazards, and that children must be properly restrained in a back seat, your vehicle has warning labels on the dashboard (U.S. models) and on the front visors. Please read and follow the instructions on these labels.

U.S. Models

SUN VISORS



Canadian Models

SUN VISORS

<p>CAUTION TO AVOID SERIOUS INJURY:</p> <ul style="list-style-type: none">• FOR MAXIMUM SAFETY PROTECTION IN ALL TYPES OF CRASHES, YOU MUST ALWAYS WEAR YOUR SAFETY BELT.• DO NOT INSTALL REARWARD-FACING CHILD SEATS IN ANY FRONT PASSENGER SEAT POSITION.• DO NOT SIT OR LEAN UNNECESSARILY CLOSE TO THE AIR BAG.• DO NOT PLACE ANY OBJECTS OVER THE AIR BAG OR BETWEEN THE AIR BAG AND YOURSELF.• SEE THE OWNER'S MANUAL FOR FURTHER INFORMATION AND EXPLANATIONS.	<p>PRECAUTIONS: POUR EVITER DES BLESSURES GRAVES:</p> <ul style="list-style-type: none">• POUR PROFITER D'UNE PROTECTION MAXIMALE LORS D'UNE COLLISION BOUCLEZ TOUJOURS VOTRE CEINTURE DE SECURITE.• N'INSTALLEZ JAMAIS UN SIEGE POUR ENFANTS FAISANT FACE A L'ARRIERE SUR LE SIEGE DU PASSAGER AVANT.• NE VOUS APPUYEZ PAS ET NE VOUS ASSOYEZ PAS PRES DU COUSSIN GONFLABLE.• NE DEPOSEZ AUCUN OBJET SUR LE COUSSIN GONFLABLE OU ENTRE LE COUSSIN GONFLABLE ET VOUS.• LISEZ LE GUIDE UTILISATEUR POUR DE PLUS AMPLES RENSEIGNEMENTS.
--	--

DASHBOARD

This Vehicle is Equipped with Advanced Air Bags

Even with Advanced Air Bags

Children can be killed or seriously injured by the air bag. The back seat is the safest place for children. Never put a rear-facing child seat in the front. Always use seat belts and child restraints. See owner's manual for more information about air bags.

To be removed by owner only.

Protecting Children – General Guidelines

If You Must Drive with Several Children

Your vehicle has a back seat where children can be properly restrained. If you ever have to carry a group of children, and a child must ride in front:

- Place the largest child in the front seat, provided the child is large enough to wear the lap/shoulder belt properly (see page 48).
- Move the vehicle seat as far to the rear as possible (see page 95).
- Have the child sit upright and well back in the seat (see page 15).
- Make sure the seat belt is properly positioned and secured (see page 14).

If a Child Requires Close Attention

Many parents say they prefer to put an infant or a small child in the front passenger seat so they can watch the child, or because the child requires attention.

Placing a child in the front seat exposes the child to hazards in a frontal collision, and paying close attention to a child distracts the driver from the important tasks of driving, placing both of you at risk.

If a child requires close physical attention or frequent visual contact, we strongly recommend that another adult ride with the child in the back seat. The back seat is far safer for a child than the front.

Additional Safety Precautions

- ***Never hold an infant or child on your lap.*** If you are not wearing a seat belt in a crash, you could be thrown forward and crush the child against the dashboard or a seat-back. If you are wearing a seat belt, the child can be torn from your arms and be seriously hurt or killed.
- ***Never put a seat belt over yourself and a child.*** During a crash, the belt could press deep into the child and cause serious or fatal injuries.
- ***Never let two children use the same seat belt.*** If they do, they could be very seriously injured in a crash.

- ***Make sure any unused seat belt that a child can reach is buckled, the lockable retractor is activated, and the belt is fully retracted and locked.*** If a child wraps a loose seat belt around their neck, they can be seriously or fatally injured. (See pages 44 and 45 for how to activate and deactivate the lockable retractor.)
- ***Do not leave children alone in a vehicle.*** Leaving children without adult supervision is illegal in most states, Canadian provinces and territories, and can be very hazardous.

For example, infants and small children left in a vehicle on a hot day can die from heatstroke. A child left alone with the key in the ignition switch can accidentally set the vehicle in motion, possibly injuring themselves or others.

- ***Lock both doors and the trunk when your vehicle is not in use.*** Children who play in vehicles can accidentally get trapped inside. Teach your children not to play in or around vehicles. Know how to operate the emergency trunk opener and decide if your children should be shown how to use this feature (see page 94).
- ***Keep vehicle keys/remote transmitters out of the reach of children.*** Even very young children learn how to unlock vehicle doors, turn on the ignition switch, and open the trunk, which can lead to accidental injury or death.

Protecting Infants and Small Children

Protecting Infants

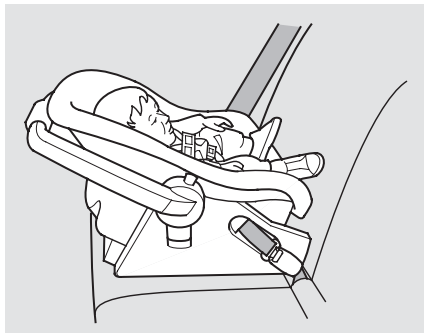

Child Seat Type

An infant must be properly restrained in a rear-facing, reclining child seat until the child reaches the seat maker's weight or height limit for the seat, and the child is at least one year old.

Only a rear-facing child seat provides proper support for a baby's head, neck, and back.

Two types of seats may be used: a seat designed exclusively for infants, or a convertible seat used in the rear-facing, reclining mode.

Do not put a rear-facing child seat in a forward-facing position. If placed facing forward, an infant could be very seriously injured during a frontal collision.

Rear-facing Child Seat Placement

A rear-facing child seat can be placed in any seating position in the back seat, but not in the front. **Never put a rear-facing child seat in the front seat.**

If the passenger's front airbag inflates, it can hit the back of the child seat with enough force to kill or seriously injure an infant.

When properly installed, a rear-facing child seat may prevent the driver or a front passenger from

moving their seat as far back as recommended, or from locking their seat-back in the desired position.

It can also interfere with proper operation of the passenger's advanced front airbag system.

In any of these situations, we strongly recommend that you install the child seat directly behind the front passenger's seat, move the seat as far forward as needed, and leave it unoccupied. Or, you may wish to get a smaller rear-facing child seat.

⚠ WARNING

Placing a rear-facing child seat in the front seat can result in serious injury or death during a crash.

Always place a rear-facing child seat in the back seat, not the front.

Protecting Small Children



Child Seat Type

Many states, Canadian provinces and territories allow a child one year of age or older who also meets the minimum size and weight requirements to transition from a rear-facing child seat to a forward facing seat. Know the requirements where you are driving and follow the child seat instructions. Many experts recommend use of a rear-facing seat up to age two, if the child's height

and weight are appropriate for a rear-facing seat.

Of the different seats available, we recommend those that have a five-point harness system as shown.

We also recommend that a small child use the child seat until the child reaches the weight or height limit for the seat.

Child Seat Placement

We strongly recommend placing a forward-facing child seat in a back seat, not the front.

Placing a forward-facing child seat in the front seat of a vehicle equipped with a passenger's airbag can be hazardous. If the vehicle seat is too far forward, or the child's head is thrown forward during a collision, an inflating airbag can strike the child with enough force to cause very serious or fatal injuries.

Even with advanced front airbags that automatically turn the passenger's front airbag off (see page 25), a back seat is the safest place for a small child.

CONTINUED

Protecting Infants and Small Children, Selecting a Child Seat

If it is necessary to put a forward-facing child seat in the front, move the vehicle seat as far to the rear as possible, and be sure the child seat is firmly secured to the vehicle and the child is properly strapped in the seat.

⚠ WARNING

Placing a forward-facing child seat in the front seat can result in serious injury or death if the front airbag inflates.

If you must place a forward-facing child seat in front, move the vehicle seat as far back as possible, and properly restrain the child.

Selecting a Child Seat

When buying a child seat, you need to choose either a conventional child seat, or one designed for use with the Lower Anchors and Tethers for Children (LATCH) system.

Conventional child seats must be secured to a vehicle with a seat belt, whereas LATCH-compatible seats are secured by attaching the seat to hardware built into the two outer seating positions in the back seat.

Since LATCH-compatible child seats are easier to install and reduce the possibility of improper installation, we recommend selecting this style.

In seating positions and vehicles not equipped with LATCH, a LATCH-compatible child seat can be installed using a seat belt.

Whatever type of seat you choose, to provide proper protection, a child seat should meet three requirements:

- 1. The child seat should meet Federal Motor Vehicle Safety Standard 213 or Canadian Motor Vehicle Safety Standard 213.***
Look for FMVSS 213 or CMVSS 213 on the box.
- 2. The child seat should be of the proper type and size to fit the child.***
Rear-facing for infants, forward-facing for small children.

3. The child seat should fit the vehicle seating position (or positions) where it will be used.

Before purchasing a conventional child seat, or using a previously purchased one, we recommend that you test the seat in the specific vehicle seating position or positions where the seat will be used.

Installing a Child Seat

After selecting a proper child seat and a good place to install the seat, there are three main steps in installing the seat:

1. Properly secure the child seat to the vehicle. All child seats must be secured to the vehicle with the lap part of a lap/shoulder belt or with the LATCH (Lower Anchors and Tethers for CHildren) system. A child whose seat is not properly secured to the vehicle can be endangered in a crash.

2. Make sure the child seat is firmly secured. After installing a child seat, push and pull the seat forward and from side-to-side to verify that it is secure.

A child seat secured with a seat belt should be installed as firmly as possible. However, it does not need to be “rock solid.” Some side-to-side

movement can be expected and should not reduce the child seat’s effectiveness.

If the child seat is not secure, try installing it in a different seating position, or use a different style of child seat that can be firmly secured.

3. Secure the child in the child seat. Make sure the child is properly strapped in the child seat according to the child seat maker’s instructions. A child who is not properly secured in a child seat can be seriously injured in a crash.

The following pages provide guidelines on how to properly install a child seat. A forward-facing child seat is used in all examples, but the instructions are the same for rear-facing child seats.

Installing a Child Seat

Installing a Child Seat with LATCH

Your vehicle is equipped with LATCH (Lower Anchors and Tethers for Children) at the outer rear seats.

The lower anchors are located between the seat-back and seat bottom, and are to be used only with a child seat designed for use with LATCH.

The location of each lower anchor is indicated by a small button above the anchor point.

To install a LATCH-compatible child seat:

1. Move the seat belt buckle or tongue away from the lower anchors.

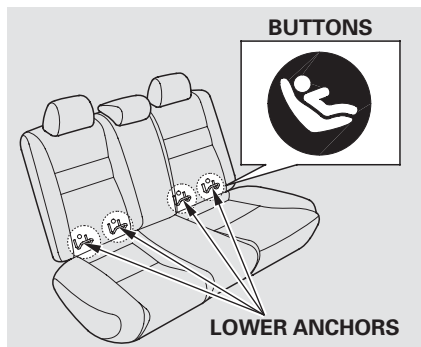

2. Make sure there are no objects near the anchors that could prevent a secure connection between the child seat and the anchors.
3. Unlock the seat-back from inside the trunk by pulling the release (see page 102), then fold it forward slightly to make a space between the rear window and the head restraint.

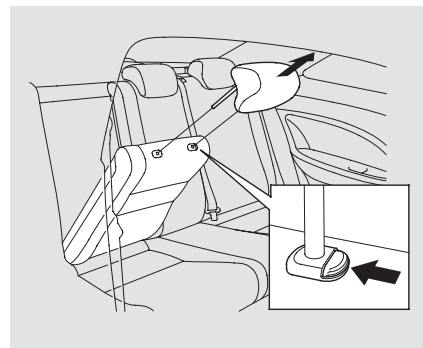

4. Remove the head restraint (see page 99). Make sure the removed head restraint is stored in the trunk. Reinstall the head restraint when the child seat is removed.
5. Lock the seat-back upright by pushing it firmly against the trunk panel.

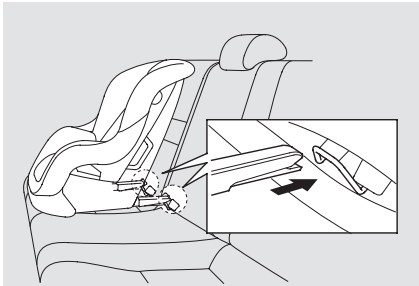

Rigid type

6. Place the child seat on the vehicle seat, then attach the seat to the lower anchors according to the child seat maker's instructions.

Some LATCH-compatible seats have a rigid-type connector as shown above.

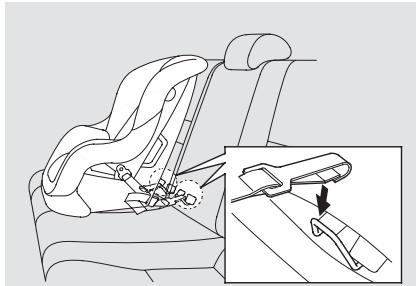

Flexible type

7. Whatever type you have, follow the child seat maker's instructions for adjusting or tightening the fit.

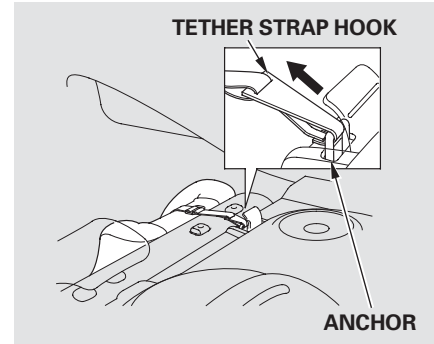

8. Route the tether strap over the seat-back, making sure the strap is not twisted.
9. Attach the tether strap hook to the tether anchor, then tighten the strap as instructed by the child seat maker.
10. Push and pull the child seat forward and from side-to-side to verify that it is secure.

Installing a Child Seat

Installing a Child Seat with a Lap/Shoulder Belt

When not using the LATCH system, all child seats must be secured to the vehicle with the lap part of a lap/shoulder belt.

In addition, the lap/shoulder belts in all seating positions except the driver's have a lockable retractor that must be activated to secure a child seat.

1. If you place the child seat in either rear outer seating position and use the tether strap for additional security, make sure to remove the head restraint (see page 46) before securing the child seat with the lap/shoulder belt.



2. With the child seat in the desired seating position, route the belt through the child seat according to the seat maker's instructions, then insert the latch plate into the buckle and remove any slack from the lap portion of the belt.



3. To activate the lockable retractor, slowly pull the shoulder part of the belt all the way out until it stops, then let the belt feed back into the retractor.
4. After the belt has retracted, tug on it. If the belt is locked, you will not be able to pull it out. If you can pull the belt out, it is not locked, and you will need to repeat these steps.



5. After confirming that the belt is locked, grab the shoulder part of the belt near the buckle, and pull up to remove any slack from the lap part of the belt. Remember, if the lap part of the belt is not tight, the child seat will not be secure.

To remove slack, it may help to put weight on the child seat, or push on the back of the seat while pulling up on the belt.



6. Push and pull the child seat forward and from side-to-side to verify that it is secure enough to stay upright during normal driving maneuvers. If the child seat is not secure, unlatch the belt, allow it to retract fully, then repeat these steps.

To deactivate the lockable retractor and remove a child seat, unlatch the buckle, unrout the seat belt, and let the belt fully retract.

Installing a Child Seat

Installing a Child Seat with a Tether

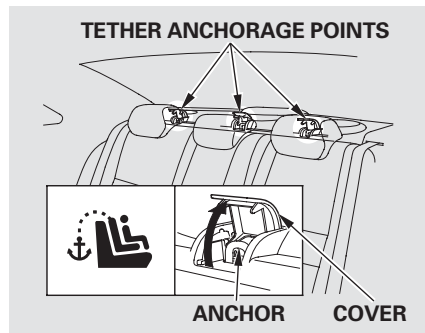

A child seat with a tether can be installed in any seating position in the back seat, using one of the anchorage points shown above.

Since a tether can provide additional security to the lap/shoulder belt installation, we recommend using a tether whenever one is required or available.

Using an Outer Anchor

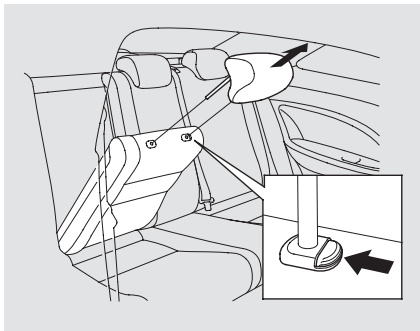

1. Unlock the seat-back from inside the trunk by pulling the release (see page 102), then fold it forward slightly to make a space between the rear window and the head restraint.
2. Remove the head restraint (see page 99). Make sure the removed head restraint is stored in the trunk. Reinstall the head restraint when the child seat is removed.

3. Lock the seat-back upright by pushing it firmly against the trunk panel.
4. After properly securing the child seat (see page 44), route the tether strap over the seat-back.

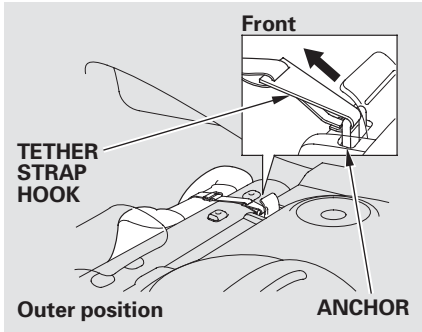

5. Lift the cover, then attach the tether strap hook to the anchor, making sure the strap is not twisted.
6. Tighten the strap according to the seat maker's instructions.

Using the Center Anchor

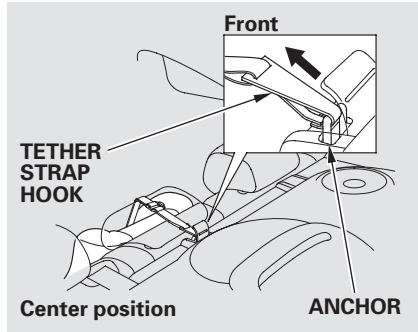

1. After properly securing the child seat (see page 44), adjust the head restraint to its lowest position, then route the tether strap over the head restraint.
2. Lift the anchor cover, then attach the tether strap hook to the anchor, making sure the strap is not twisted.

3. Tighten the strap according to the seat maker's instructions.

Protecting Larger Children

When a child reaches the recommended weight or height limit for a forward-facing child seat, the child should sit in a back seat on a booster seat and wear the lap/shoulder belt.

The following pages give instructions on how to check proper seat belt fit, what kind of booster seat to use if one is needed, and important precautions for a child who must sit in front.

⚠ WARNING

Allowing a child age 12 or under to sit in front can result in injury or death if the passenger's front airbag inflates.

If a child must ride in front, move the vehicle seat as far back as possible, use a booster seat if needed, have the child sit up properly and wear the seat belt properly.

Checking Seat Belt Fit



To determine if a lap/shoulder belt properly fits a child, have the child put on the seat belt, then ask yourself:

1. Does the child sit all the way back against the seat?
2. Do the child's knees bend comfortably over the edge of the seat?

3. Does the shoulder belt cross between the child's neck and arm?
4. Is the lap part of the belt as low as possible, touching the child's thighs?
5. Will the child be able to stay seated like this for the whole trip?

If you answer yes to all these questions, the child is ready to wear the lap/shoulder belt correctly. If you answer no to any question, the child needs to ride on a booster seat.

Using a Booster Seat



A child who has outgrown a forward-facing child seat should ride in a back seat and use a booster seat until the lap/shoulder belt fits them properly without the booster.

Some states, Canadian provinces and territories also require children to use a booster seat until they reach a given age or weight (e.g., 6 years or 60 lbs). Be sure to check current laws in the states, provinces or territories where you intend to drive.

Booster seats can be high-back or low-back. Whichever style you select, make sure the booster seat meets federal safety standards (see page 40) and that you follow the booster seat maker's instructions.

If a child who uses a booster seat must ride in front, move the vehicle seat as far back as possible, and be sure the child is wearing the seat belt properly.

CONTINUED

Protecting Larger Children

A child may continue using a booster seat until the tops of their ears are even with the top of the vehicle's or booster's seat-back. A child of this height should be tall enough to use the lap/shoulder belt without a booster seat.

When Can a Larger Child Sit in Front

The National Highway Traffic Safety Administration and Transport Canada recommend that all children age 12 and under be properly restrained in the back seat.

If the passenger's front airbag inflates in a moderate to severe frontal collision, the airbag can cause serious injuries to a child who is unrestrained, improperly restrained, sitting too close to the airbag, or out of position.

A side airbag also poses risks. If any part of a larger child's body is in the path of a deploying side airbag, the child could receive possibly serious injuries.

Of course, children vary widely. And while age may be one indicator of when a child can safely ride in front, there are other important factors you should consider.

Physical Size

Physically, a child must be large enough for the lap/shoulder belt to properly fit (see pages 14 and 48). If the seat belt does not fit properly, with or without the child sitting on a booster seat, the child should not sit in front.

Maturity

To safely ride in front, a child must be able to follow the rules, including sitting properly, and wearing the seat belt properly throughout a ride.

If you decide that a child can safely ride up front, be sure to:

- Carefully read the owner's manual, and make sure you understand all seat belt instructions and all safety information.
- Move the vehicle seat to the rear-most position.
- Have the child sit up straight, back against the seat, and feet on or near the floor.
- Check that the child's seat belt is properly and securely positioned.
- Supervise the child. Even mature children sometimes need to be reminded to fasten the seat belts or sit properly.

Additional Safety Precautions

- ***Do not let a child wear a seat belt across the neck.*** This could result in serious neck injuries during a crash.
- ***Do not let a child put the shoulder part of a seat belt behind the back or under the arm.*** This could cause very serious injuries during a crash. It also increases the chance that the child will slide under the belt in a crash and be injured.
- ***Two children should never use the same seat belt.*** If they do, they could be very seriously injured in a crash.

- ***Do not put any accessories on a seat belt.*** Devices intended to improve a child's comfort or reposition the shoulder part of a seat belt can make the belt less effective and increase the chance of serious injury in a crash.

Carbon Monoxide Hazard

Your vehicle's exhaust contains carbon monoxide gas. Carbon monoxide should not enter the vehicle in normal driving if you maintain your vehicle properly and follow the information on this page.

Have the exhaust system inspected for leaks whenever:

- The vehicle is raised for an oil change.
- You notice a change in the sound of the exhaust.
- The vehicle was in a crash that may have damaged the underside.

⚠ WARNING

Carbon monoxide gas is toxic. Breathing it can cause unconsciousness and even kill you.

Avoid any enclosed areas or activities that expose you to carbon monoxide.

High levels of carbon monoxide can collect rapidly in enclosed areas, such as a garage. Do not run the engine with the garage door closed. Even with the door open, run the engine only long enough to move the vehicle out of the garage.

With the trunk open, airflow can pull exhaust gas into your vehicle's interior and create a hazardous condition. If you must drive with the trunk open, open all the windows and set the heating and cooling system as shown below.

If you must sit in your parked vehicle with the engine running, even in an unconfined area, adjust the heating and cooling system as follows:

1. Select the fresh air mode.
2. Select the  mode.
3. Turn the fan on high speed.
4. Set the temperature control to a comfortable setting.

These labels are in the locations shown. They warn you of potential hazards that could cause serious injury or death. Read these labels carefully.

If a label comes off or becomes hard to read (except for the U.S. dashboard label which may be removed by the owner), contact your dealer for a replacement.

RADIATOR CAP

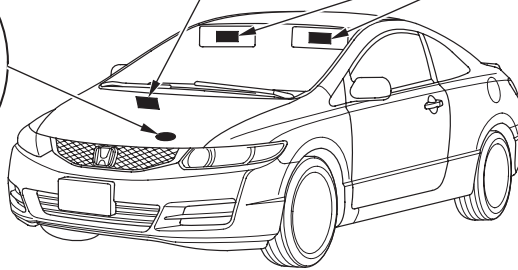

DASHBOARD

U.S. models only

This Vehicle is Equipped with
Advanced Air Bags

Even with Advanced Air Bags

Children can be killed or seriously injured by the air bag.
The back seat is the safest place for children.
Never put a rear-facing child seat in the front.
Always use seat belts and child restraints.
See owner's manual for more information about air bags.

To be removed by owner only.

SUN VISOR

U.S. models



Canadian models

<p>CAUTION</p> <p>TO AVOID SERIOUS INJURY: FOR MAXIMUM SAFETY PROTECTION IN ALL TYPES OF CRASHES, YOU MUST ALWAYS WEAR YOUR SAFETY BELT.</p> <p>DO NOT INSTALL REARWARD-FACING CHILD SEATS IN ANY FRONT PASSENGER SEAT POSITION.</p> <p>DO NOT SIT OR LEAN UNNECESSARILY CLOSE TO THE AIR BAG.</p> <p>DO NOT PLACE ANY OBJECTS OVER THE AIR BAG OR BETWEEN THE AIR BAG AND YOURSELF.</p> <p>SEE THE OWNER'S MANUAL FOR FURTHER INFORMATION AND EXPLANATIONS.</p>	<p>PRECAUTIONS:</p> <p>POUR ÉVITER DES BLESSURES GRAVES: POUR PROFITER D'UNE PROTECTION MAXIMALE LORS D'UNE COLLISION BOUCLEZ TOUJOURS VOTRE CEINTURE DE SÉCURITÉ.</p> <p>N'INSTALLEZ JAMAIS UN SIÈGE POUR ENFANTS FAISANT FACE À L'ARRIÈRE SUR LE SIÈGE DU PASSAGER AVANT.</p> <p>NE VOUS ASSOYEZ PAS ET NE VOUS ASSOYEZ PAS PRES DU COUSSIN GONFLABLE.</p> <p>NE DÉPOSEZ AUCUN OBJET SUR LE COUSSIN GONFLABLE OU ENTRE LE COUSSIN GONFLABLE ET VOUS.</p> <p>LISEZ LE GUIDE UTILISATEUR POUR DE PLUS AMPLES RENSEIGNEMENTS.</p>
---	---

CONTINUED

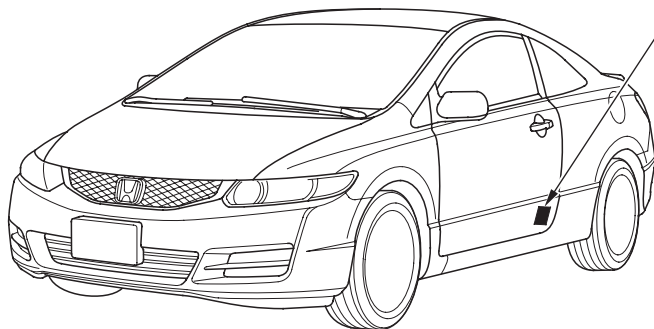

DOORJAMBS

U.S. models

SIDE AIRBAG

- This car is equipped with side airbags in the front seats and side curtain airbags.
- Do not lean against the door.
- See owner's manual for more information.

Canadian models

SIDE AIRBAG

- This car is equipped with side airbags in the front seats and side curtain airbags.
- Do not lean against the door.
- See owner's manual for more information.

COUSSIN GONFLABLE LATERAL

- Cette automobile est équipée de coussins gonflables de coussins latéraux dans les sièges avant ainsi que de coussins gonflables latéraux de type rideau.
- Ne vous appuyez pas sur la porte.
- Consultez le Manuel du propriétaire pour en savoir plus.

This section gives information about the controls and displays that contribute to the daily operation of your vehicle. All the essential controls are within easy reach.

Control Locations	56	Door Locks	82
Instrument Panel	57	Power Door Locks.....	83
Instrument Panel Indicators.....	59	Auto Door Locking/Unlocking..	84
Gauges	67	Remote Transmitter	89
Display Change Button.....	68	Trunk.....	93
Odometer.....	68	Emergency Trunk Opener	94
Trip Meter	68	Seats	95
Outside Temperature		Seat Heaters	103
Indicator.....	69	Power Windows	104
Fuel Gauge	70	Moonroof	106
Temperature Gauge.....	70	Mirrors.....	108
Check Fuel Cap Message.....	70	Parking Brake	109
Maintenance Minder™	71	Interior Convenience Items.....	110
Controls Near the Steering		Beverage Holders.....	111
Wheel	72	Console Compartment	111
Windshield Wipers and Washers..	73	Glove Box	111
Turn Signals and Headlights.....	74	Coat Hook.....	112
Fog Lights.....	75	Accessory Power Sockets.....	112
Instrument Panel Brightness	76	Vanity Mirror	113
Hazard Warning Button.....	77	Sun Visor	114
Rear Window Defogger	77	Interior Lights	114
Steering Wheel Adjustments	78	Ceiling Light.....	114
Keys and Locks.....	79	Spotlights.....	115
Immobilizer System.....	80	Courtesy Light	116
Ignition Switch	81		

Control Locations

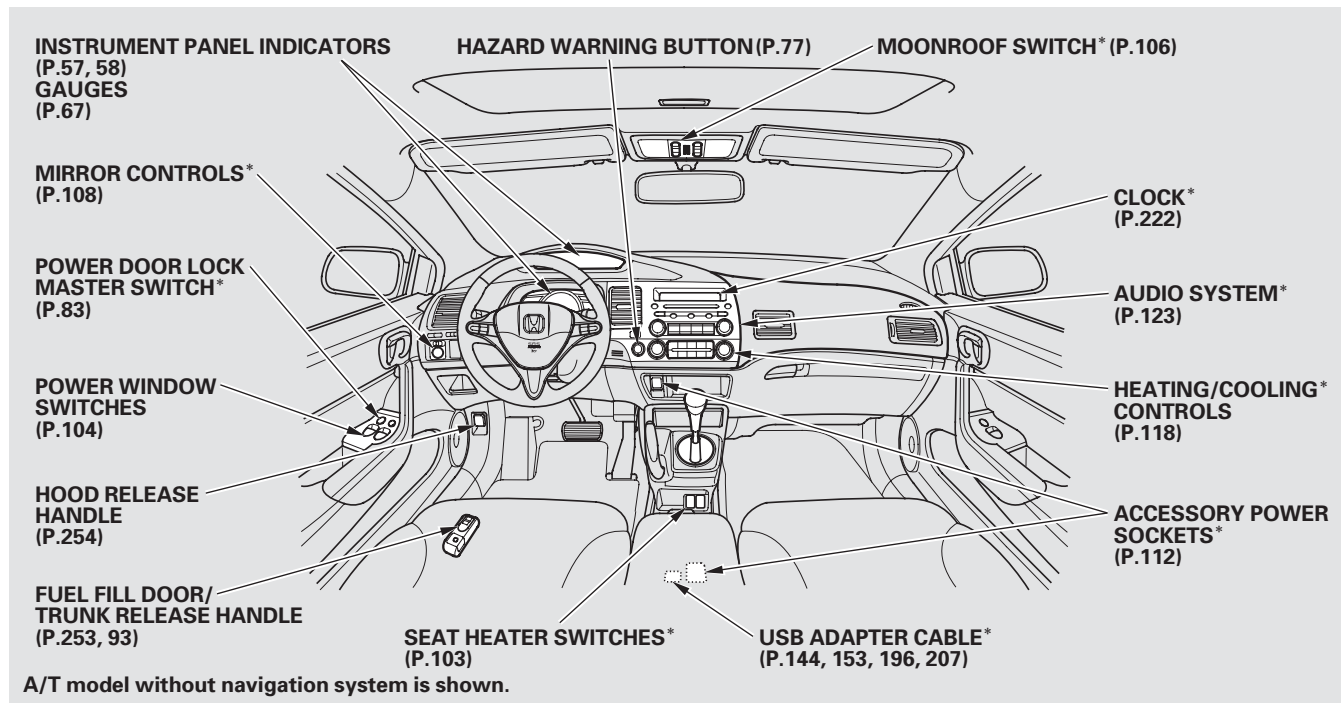

*: If equipped

DX, LX, EX, EX-L in the U.S., and DX-G, SE, EX, EX-L in Canada

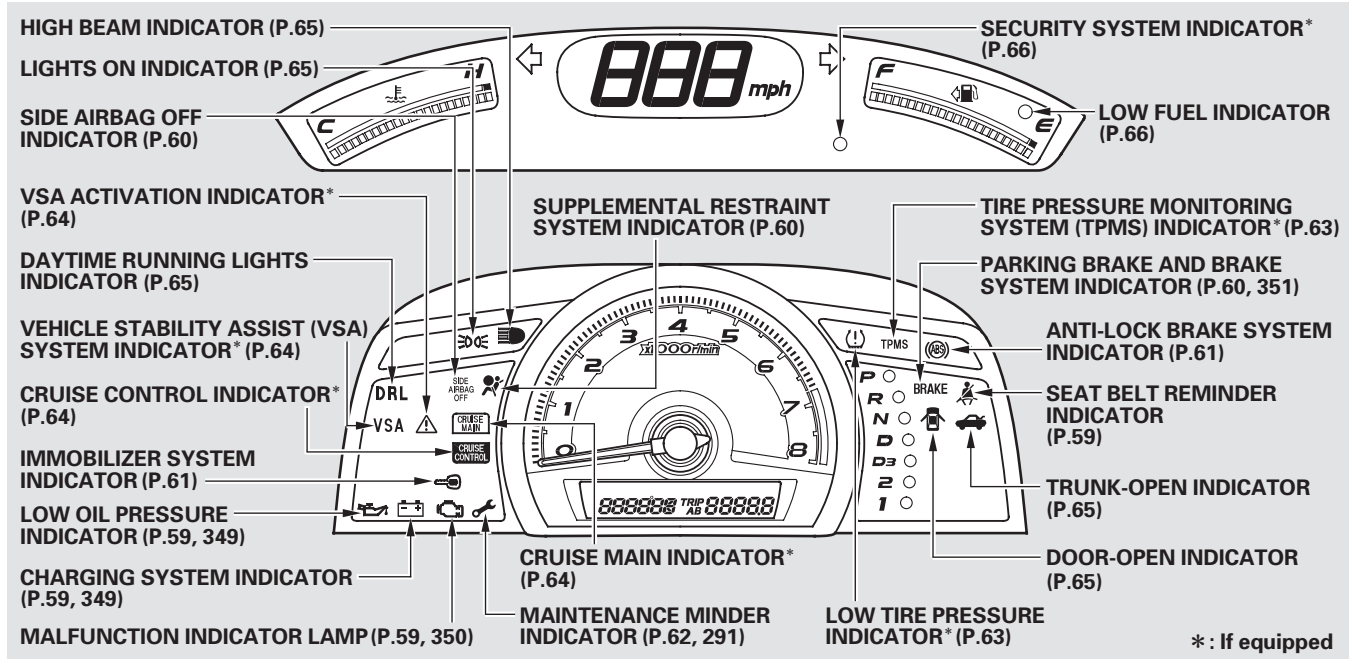

The U.S. instrument panel is shown. Differences for Canadian models are noted in the text.

CONTINUED

Canadian DX-G model with M/T has the electric power steering (EPS) indicator (see page 62) next to the immobilizer system indicator.

Instrument Panel

Si

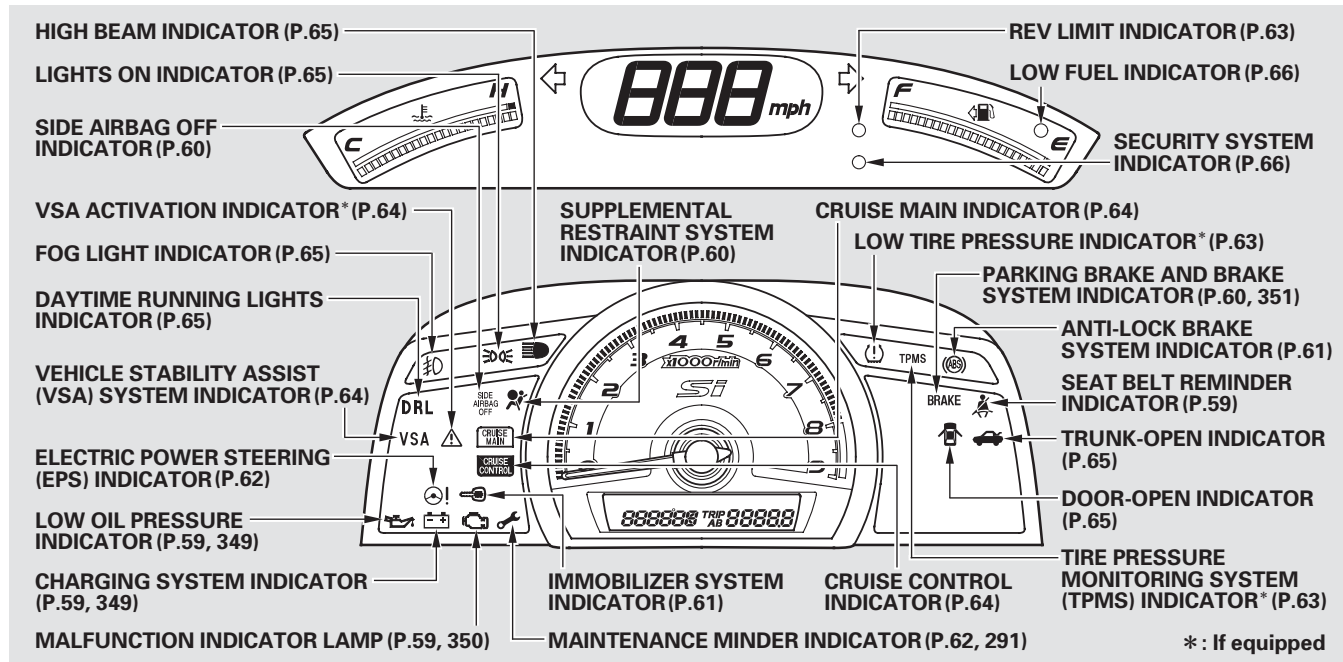

The U.S. instrument panel is shown. Differences for Canadian models are noted in the text.

The instrument panel has many indicators to give you important information about your vehicle.



Seat Belt Reminder Indicator

This indicator comes on when you turn the ignition switch to the ON (II) position. It reminds you and your passengers to fasten your seat belts. A beeper also sounds if you have not fastened your seat belt.

If you turn the ignition switch to the ON (II) position before fastening your seat belt, the beeper sounds and the indicator flashes. If you do not fasten your seat belt before the beeper stops, the indicator stops flashing but remains on.

If your front passenger does not fasten their seat belt, the indicator comes on about 6 seconds after the ignition switch is turned to the ON (II) position.

If either of you do not fasten your seat belt while driving, the beeper will sound and the indicator will flash again at regular intervals. For more information, see page 18 .



Charging System Indicator

If this indicator comes on when the engine is running, the battery is not being charged. For more information, see page 349 .



Low Oil Pressure Indicator

The engine can be severely damaged if this indicator flashes or stays on when the engine is running. For more information, see page 349 .



Malfunction Indicator Lamp

See page 350 .

Instrument Panel Indicators

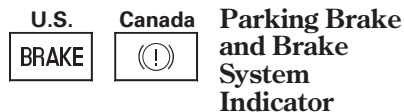

This indicator has two functions:

1. It comes on when you turn the ignition switch to the ON (II) position. It is a reminder to check the parking brake. A beeper sounds if you drive with the parking brake not fully released. Driving with the parking brake not fully released can damage the brakes and tires.
2. If it stays on after you have fully released the parking brake while the engine is running, or if it comes on while driving, there could be a problem with the brake system. For more information, see page 351 .



This indicator comes on briefly when you turn the ignition switch to the ON (II) position. If it comes on at any other time, it indicates a potential problem with your front airbags. This indicator will also alert you to a potential problem with your airbag system components. For more information, see page 29 .



This indicator comes on briefly when you turn the ignition switch to the ON (II) position. If it comes on at any other time, it indicates that the passenger's side airbag has automatically shut off. For more information, see page 30 .



Anti-lock Brake System (ABS) Indicator

This indicator normally comes on for a few seconds when you turn the ignition switch to the ON (II) position. If it comes on at any other time, there is a problem with the ABS. If this happens, have your vehicle checked at a dealer. With this indicator on, your vehicle still has normal braking ability but no anti-lock function. For more information, see page 280 .



Immobilizer System Indicator

This indicator comes on briefly when you turn the ignition switch to the ON (II) position. It will then go off if you have inserted a properly coded ignition key. If it is not a properly coded key, the indicator will blink, and the engine's fuel system will be disabled (see page 80).



Turn Signal and Hazard Warning Indicators

The left or right turn signal indicator blinks when you signal a lane change or turn. If an indicator does not blink or blinks rapidly, it usually means one of the turn signal bulbs is burned out (see pages 315 and 316). Replace the bulb as soon as possible, since other drivers cannot see that you are signaling.

When you press the hazard warning button, both turn signal indicators and all turn signals on the outside of the vehicle flash.

Instrument Panel Indicators



Electric Power Steering (EPS) Indicator

Si and Canadian DX-G with manual transmission models

This indicator normally comes on when you turn the ignition switch to the ON (II) position and goes off after the engine starts. If it comes on at any other time, there is a problem in the electric power steering system. If this happens, stop the vehicle in a safe place, and turn off the engine. Reset the system by restarting the engine. The indicator will not turn off immediately. If it does not go off after driving a short distance, or comes back on again while driving, take the vehicle to your dealer to have it checked. With the indicator on, the EPS may be off, making the vehicle harder to steer.

If you turn the steering wheel to the full left or right position repeatedly while stopping or driving at very low speed, you may feel slightly harder steering due to overheating of the steering gearbox.

Continuously driving under those conditions could damage the power steering system.



Maintenance Minder Indicator

This indicator comes on for a few seconds when you turn the ignition switch to the ON (II) position. It reminds you that it is time to take your vehicle in for scheduled maintenance. The maintenance main items and sub items will be displayed in the information display. See page 291 for more information on the Maintenance Minder™.

This indicator goes off when your dealer resets it after completing the required maintenance service.



Low Tire Pressure Indicator

U.S. models only

This indicator normally comes on for a few seconds when you turn the ignition switch to the ON (II) position. If it comes on while driving, it indicates that one or more of your vehicle's tires are significantly low on pressure.

If this happens, pull to the side of the road when it is safe, check which tire has lost pressure, and determine the cause. If it is because of a flat tire, replace the flat tire with the compact spare (see page 339), and have the flat tire repaired as soon as possible. If two or more tires are underinflated, call a professional towing service (see page 358). For more information, see page 284.



Tire Pressure Monitoring System (TPMS) Indicator

U.S. models only

This indicator normally comes on for a few seconds when you turn the ignition switch to the ON (II) position.

If this indicator comes on and stays on at any other time, or if it does not come on when you turn the ignition switch to the ON (II) position, there is a problem with the TPMS. With this indicator on, the low tire pressure indicator will not come on when a tire loses pressure. Take the vehicle to your dealer to have the system checked. For more information, see page 285.

Rev Limit Indicator

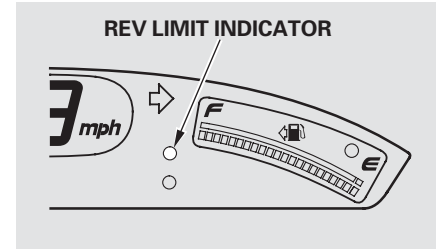

Si model only

This indicator shows you when the engine speed is near the tachometer's red zone. When the engine speed gets to near the red zone, the indicator blinks. If you exceed the maximum speed for the gear you are in, the indicator stays on, and you may feel the engine cut in and out due to the engine speed limiter (see page 273).

To protect the engine from damage, never drive with the tachometer in its red zone.

Instrument Panel Indicators



Cruise Main Indicator

If equipped

This indicator comes on when you turn on the cruise control system by pressing the CRUISE button (see page 224).



Cruise Control Indicator

If equipped

This indicator comes on when you set the cruise control. See page 224 for information on operating the cruise control.



Vehicle Stability Assist (VSA) System Indicator

If equipped

This indicator normally comes on for a few seconds when you turn the ignition switch to the ON (II) position.

If it comes on and stays on at any other time, there is a problem with the VSA system. Take your vehicle to a dealer to have it checked. Without VSA, your vehicle still has normal driving ability, but will not have VSA traction and stability enhancement. See page 282 for more information on the VSA system.



VSA Activation Indicator

If equipped

This indicator has three functions:

1. It comes on as a reminder that you have turned off the vehicle stability assist (VSA) system.
2. It flashes when VSA is active (see page 282).
3. It comes on along with the VSA system indicator if there is a problem with the VSA system.

This indicator normally comes on for a few seconds when you turn the ignition switch to the ON (II) position. See page 282 for more information on the VSA system.

DRL

Daytime Running Lights Indicator

If this indicator comes on when you turn the ignition switch to the ON (I) position and release the parking brake, it means there is a problem with the DRL. There may also be a problem with the high beam headlights. Have your vehicle checked by your dealer.



High Beam Indicator

This indicator comes on with the high beam headlights. For more information, see page 74 .

This indicator also comes on with reduced brightness when the daytime running lights (DRL) are on (see page 75).



Trunk-open Indicator

This indicator comes on if the trunk lid is not closed tightly.



Door-open Indicator

This indicator comes on if either door is not closed tightly.





Washer Level Indicator

Canadian models only

This indicator comes on when the washer fluid level is low. Add washer fluid when you see this indicator (see page 307).



Lights On Indicator

This indicator reminds you that the exterior lights are on. It comes on when the light switch is in either the  or  position. If you turn the ignition switch to the ACCESSORY (I) or LOCK (0) position without turning off the light switch, this indicator will stay on. A reminder chime will also sound when you open the driver's door.



Fog Light Indicator

If equipped

This indicator comes on when you turn on the fog lights. For more information, see page 75 .

Instrument Panel Indicators

Security System Indicator

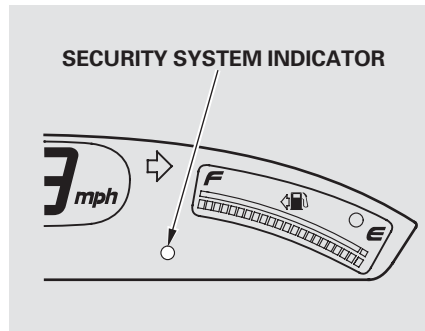

If equipped

This indicator comes on when the security system is set. See page 223 for more information on the security system.

Low Fuel Indicator

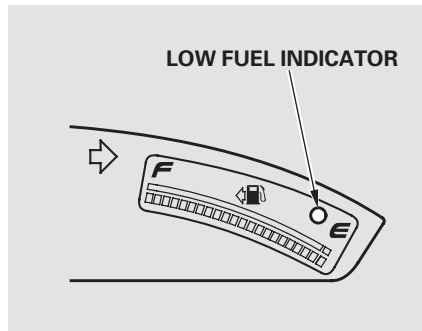

This indicator is located in the fuel gauge. It comes on as a reminder that you must refuel soon.

When the indicator comes on, there are about 1.9 US gal (7.5 l) of fuel remaining in the tank.
When the reading reaches E, there is a very small amount of fuel in the tank.

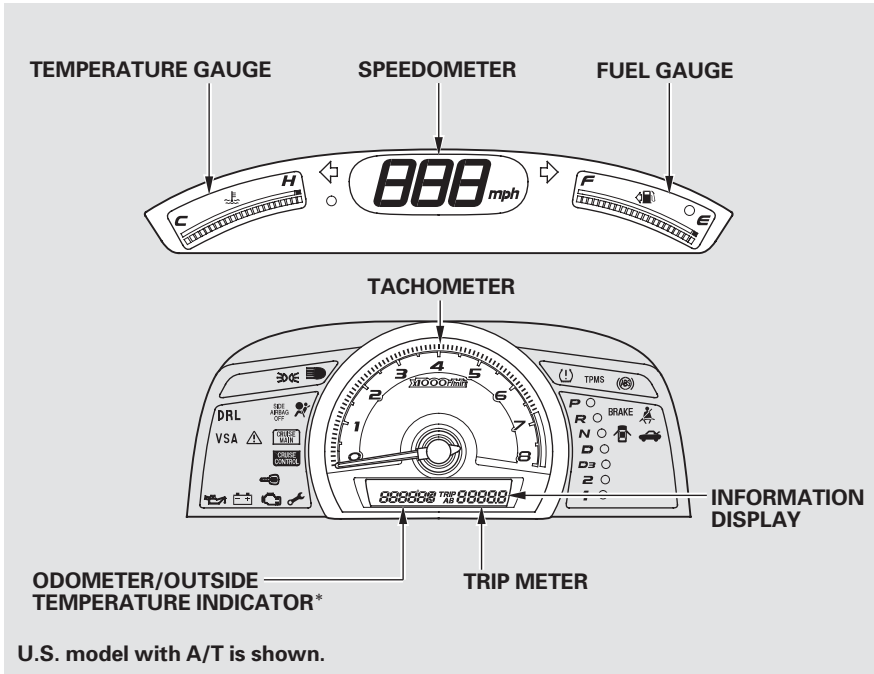

*: If equipped

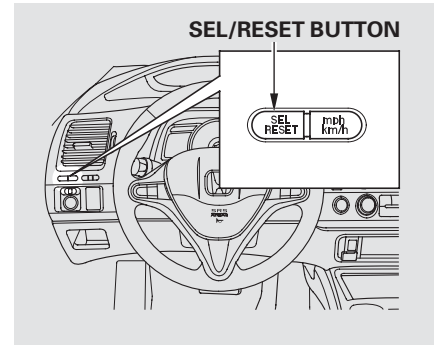

To switch the information display between the odometer, trip meter, and outside temperature (if equipped), and engine oil life and maintenance service items, press the SEL/RESET button repeatedly.

Gauges

Display Change Button

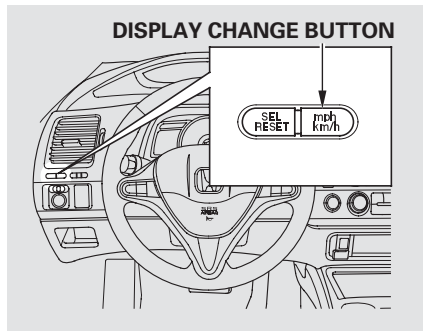

Press and hold the display change button until you hear a beep. The speedometer, trip meter, and odometer readings switch between miles per hour (mph) and kilometers per hour (km/h).

Odometer

This shows the total distance your vehicle has been driven. It measures miles or kilometers.

It is illegal under U.S. federal law and Canadian provincial and territorial regulations to disconnect, reset, or alter the odometer with the intent to change the number of miles or kilometers indicated.

The odometer and the outside temperature indicator (if equipped) use the same display. To switch the display between them, press the SEL/RESET button repeatedly. When you turn the ignition switch to the ON (II) position, your last selection is displayed.

Trip Meter

This meter shows the number of miles or kilometers driven since you last reset it.

There are two trip meters: Trip A and Trip B. Switch between these displays by pressing the SEL/RESET button repeatedly. Each trip meter works independently, so you can keep track of two different distances.

When you turn the ignition switch to the ON (II) position, your last selection is displayed.

To reset a trip meter, display it, and then press and hold the SEL/RESET button until the number resets to "0.0."

Outside Temperature Indicator

If equipped

This indicator displays the outside temperature in Fahrenheit (U.S. models) or Celsius (Canadian models). To see the outside temperature, press and release the SEL/RESET button until the temperature is shown on the information display.

The temperature sensor is in the front bumper. Therefore, the temperature reading can be affected by heat reflection from the road surface, engine heat, and the exhaust from surrounding traffic. This can cause an incorrect temperature reading when your speed is under 19 mph (30 km/h).

The sensor delays the display update until it reaches the correct outside temperature. This may take several minutes.

If the outside temperature is incorrectly displayed, you can adjust it up to $\pm 5^{\circ}\text{F}$ in U.S. models ($\pm 3^{\circ}\text{C}$ in Canadian models) warmer or cooler.

NOTE: The temperature must be stabilized before doing this procedure.

Select the outside temperature display, then press and hold the SEL/RESET button for 10 seconds. The following sequence will appear for 1 second each: 0, 1, 2, 3, 4, 5, -5, -4, -3, -2, -1, 0 (U.S.) or 0, 1, 2, 3, -3, -2, -1, 0 (Canada).

When it reaches the desired value, release the SEL/RESET button. You should see the new outside temperature displayed.

In certain weather conditions, temperature readings near freezing (32°F , 0°C) could mean that ice is forming on the road surface.

Gauges

Fuel Gauge

This shows how much fuel you have. It may show slightly more or less than the actual amount.

NOTICE

Avoid driving with an extremely low fuel level. Running out of fuel could cause the engine to misfire, damaging the catalytic converter.

Temperature Gauge

This shows the temperature of the engine's coolant. During normal operation, the reading should rise to about the middle of the gauge. In severe driving conditions, such as very hot weather or a long period of uphill driving, the reading may rise into the upper half of the gauge. If it reaches the red (Hot) mark, pull safely to the side of the road. See page 347 for instructions and precautions on checking the engine cooling system.

Check Fuel Cap Message

Your vehicle's onboard diagnostic system will detect a loose or missing fuel fill cap as an evaporative system leak. The first time a leak is detected a "CHECK FUEL CAP" message appears on the information display. Turn the engine off, and confirm the fuel fill cap is installed. If it is, loosen it, then retighten it until it clicks at least once. The message should go off after several days of normal driving once you tighten or replace the fuel fill cap. To scroll to another display, press the SEL/RESET button. The "CHECK FUEL CAP" message will appear each time you restart the engine until the system turns the message off.

If the system still detects a leak in your vehicle's evaporative emissions system, the malfunction indicator lamp (MIL) comes on. If the fuel fill cap was not already tightened, turn the engine off, and check or retighten the fuel fill cap until it clicks at least once. The MIL should go off after several days of normal driving once the cap is tightened or replaced. If the MIL does not go off, have your vehicle inspected by a dealer. For more information, see page 350 .

Maintenance Minder™

The information display in the instrument panel shows you the engine oil life and maintenance service items when the ignition switch is in the ON (II) position. This information helps to keep you aware of the periodic maintenance your vehicle needs for continued trouble-free driving. Refer to page 291 for more information.

Controls Near the Steering Wheel

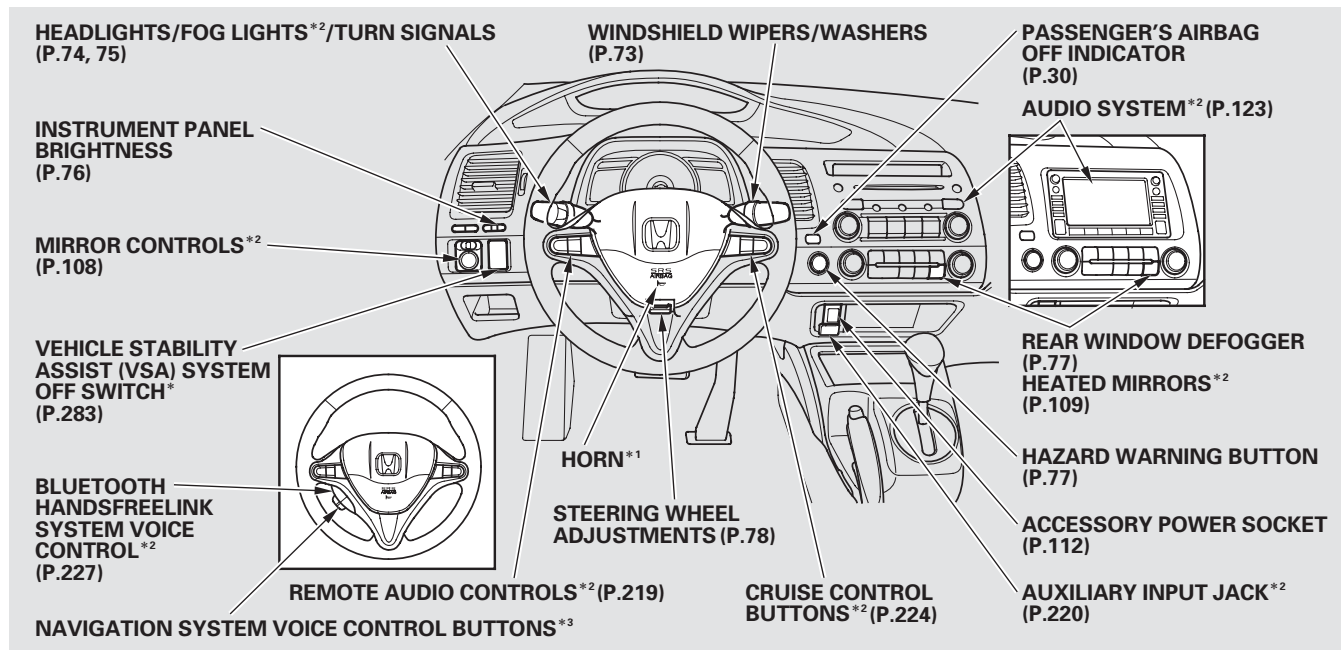

* 1 : To use the horn, press the center pad of the steering wheel.

* 2 : If equipped.

* 3 : Only on vehicles equipped with navigation system. Refer to the navigation system manual.

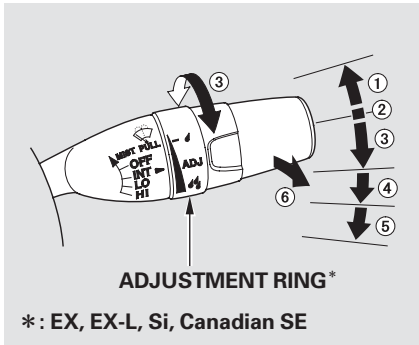

1. MIST
2. OFF
3. INT – Intermittent
4. LO – Low speed
5. HI – High speed
6. Windshield washers

Push the right lever up or down to select a position.

MIST – The wipers run at high speed until you release the lever.

OFF – The wipers are not activated.

INT – The wipers operate every few seconds.

On EX, EX-L and Si models in the U.S., and SE, EX-L and Si models in Canada
The length of the wiper interval is varied automatically according to the vehicle's speed.

Vary the delay by turning the adjustment ring. If you turn it to the shortest delay (☂ position), the wipers change to low speed operation when the vehicle speed exceeds 12 mph (20 km/h).

LO – The wipers run at low speed.

HI – The wipers run at high speed.

Windshield Washer – Pull the wiper control lever toward you, and hold it. The washers spray until you release the lever. The wipers run at low speed, then complete a few more sweeps after you release the lever.

Turn Signals and Headlights

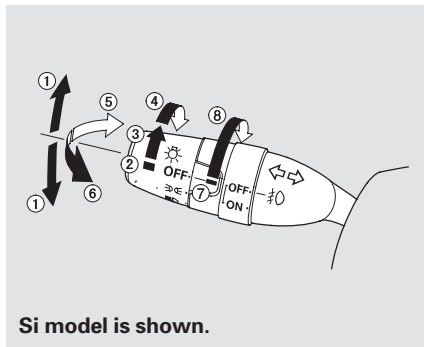



Si model is shown.



1. Turn signal
2. Off
3. Parking and instrument panel lights
4. Headlights on
5. High beams
6. Flash high beams
7. Fog lights off*
8. Fog lights on*

*: If equipped

Turn Signal — Push down on the lever to signal a left turn and up to signal a right turn. To signal a lane change, push lightly on the lever, and hold it. The lever will return to center when you release it or complete a turn.

Headlights On — Turning the switch to the “ ” position turns on the parking lights, taillights, instrument panel lights, side-marker lights, and rear license plate lights.

Turning the switch to the “ ” position turns on the headlights.

When the light switch is in the “ ” or “ ” position, the lights on indicator comes on as a reminder.

This indicator stays on if you leave the lights on and turn the ignition switch to the ACCESSORY (I) or LOCK (0) position.

If you leave the lights on with the key removed from the ignition switch, you will hear a reminder chime when you open the driver's door.

High Beams — Push the lever forward until you hear a click. The high beam indicator will come on (see page 65). Pull the lever back to return to the low beams.

To flash the high beams, pull the lever back lightly, then release it. The high beams will stay on as long as you hold the lever back.

Daytime Running Lights

With the headlight switch off or in the  position, the high beam headlights and the high beam indicator come on with reduced brightness when you turn the ignition switch to the ON (II) position and release the parking brake. They remain on until you turn the ignition switch off, even if you set the parking brake.

The headlights revert to normal operation when you turn them on with the switch.

Fog Lights

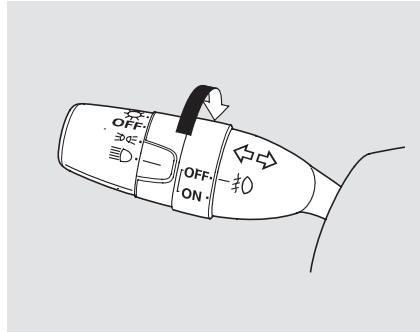

If equipped
Turn the fog lights on and off by turning the switch next to the headlight switch.

You can use the fog lights only when the headlights are on low beam. They will go off when you turn the headlights off or onto high beam.

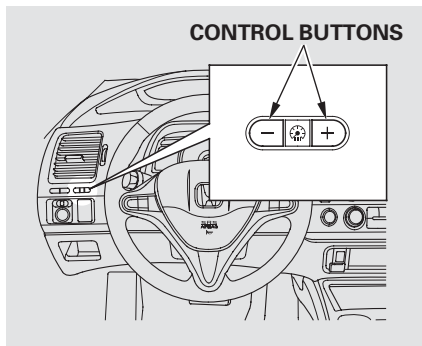

Instrument Panel Brightness



The buttons under the left side vent control the brightness of the instrument panel. Push the + or - button to adjust the brightness.

Separate adjustments can be made when the headlights are on and off.

There are six brightness levels. When you push either button, the information display indicates the current level. You will hear a tone when you reach the maximum or minimum brightness. The display returns to the odometer 5 seconds after you stop adjusting the brightness.

To reduce glare at night, the instrument panel illumination dims when you turn the light switch to the  or  position.

The center of each meter (upper and lower) illuminates with reduced brightness when you unlock and open the driver's door, and then goes back to the selected brightness when you turn the ignition switch to the ON (II) position.

If you insert the key but do not turn the ignition switch to the ON (II) position, the illumination turns off in about 10 seconds.

Hazard Warning Button, Rear Window Defogger

Hazard Warning Button

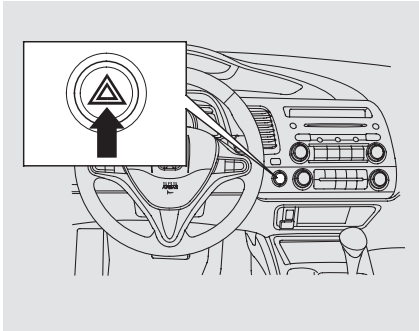

Push the button to turn on the hazard warning lights (four-way flashers). This causes all four outside turn signals and both turn indicators in the instrument panel to flash. Use the hazard warning lights if you need to park in a dangerous area near heavy traffic, or if your vehicle is disabled.

Rear Window Defogger

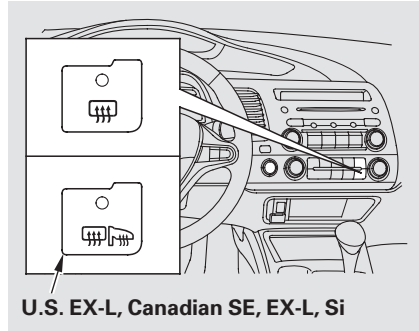

The rear window defogger will clear fog, frost, and thin ice from the window. Push the defogger button to turn it on and off. The indicator in the button comes on to show the defogger is on. If you do not turn it off, the defogger will shut itself off after about 15 minutes. It also shuts off when you turn off the ignition switch. You have to turn the defogger on again when you restart the vehicle.

Make sure the rear window is clear and you have good visibility before starting to drive.

The defogger and antenna wires on the inside of the rear window can be accidentally damaged. When cleaning the glass, always wipe side-to-side.

On U.S. EX-L, Canadian SE, EX-L and Si models

Pushing this button also turns the mirror heaters on or off. For more information, see page 109 .

Steering Wheel Adjustments

Make any steering wheel adjustments before you start driving.

⚠ WARNING

Adjusting the steering wheel position while driving may cause you to lose control of the vehicle and be seriously injured in a crash.

Adjust the steering wheel only when the vehicle is stopped.

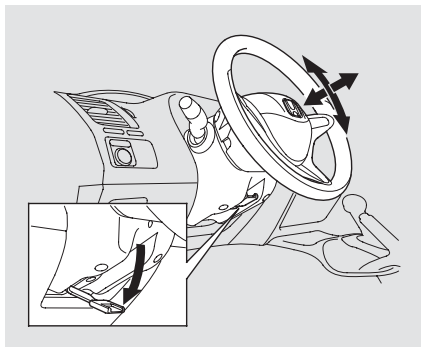

1. Push the lever under the steering column all the way down.
2. Move the steering wheel up or down, and in or out, so it points toward your chest, not toward your face. Make sure you can see the instrument panel gauges and indicators.

3. Push the lever up to lock the steering wheel in position.
4. Make sure you have securely locked the steering wheel in place by trying to move it up, down, in, and out.

All EX, EX-L and Si models, and Canadian SE model

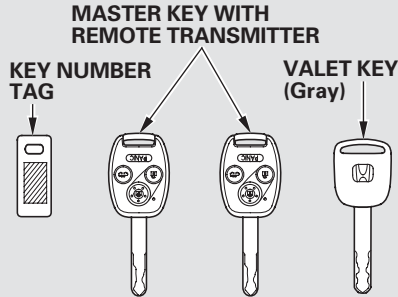

U.S. LX and Canadian DX-G models

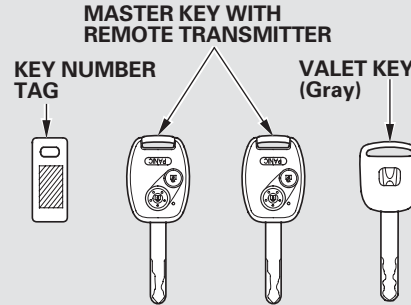

DX model (except Canadian DX-G)

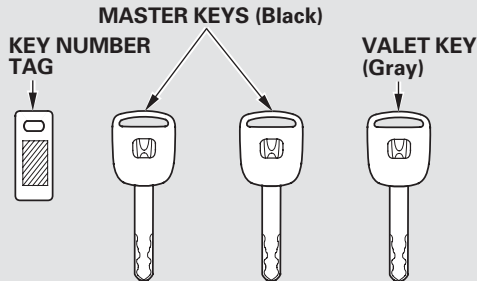

The master key fits all the locks on your vehicle. The valet key works only in the ignition and the driver's door lock*. You can keep the trunk and trunk release handle locked when you leave your vehicle and the valet key at a parking facility.

* On DX model (except Canadian DX-G), the passenger's door can also be locked or unlocked with the key.

You should have received a key number tag with your keys. You will need this key number if you ever have to get a lost key replaced. Use only Honda-approved key blanks.

CONTINUED

Keys and Locks, Immobilizer System

These keys contain electronic circuits that are activated by the immobilizer system. They will not work to start the engine if the circuits are damaged.

- Protect the keys from direct sunlight, high temperature, and high humidity.
- Do not drop the keys or set heavy objects on them.
- Keep the keys away from liquids. If they get wet, dry them immediately with a soft cloth.

The valet key does not contain a battery. Do not try to take it apart.

On DX model (except Canadian DX-G)
The keys do not contain batteries. Do not try to take them apart.

Immobilizer System

The immobilizer system protects your vehicle from theft. If an improperly coded key (or other device) is used, the engine's fuel system is disabled.

When you turn the ignition switch to the ON (II) position, the immobilizer system indicator should come on briefly, then go off. If the indicator starts to blink, it means the system does not recognize the coding of the key. Turn the ignition switch to the LOCK (0) position, remove the key, reinsert it, and turn the ignition switch to the ON (II) position again.

The system may not recognize your key's coding if another immobilizer key or other metal object (i.e. key chain) is near the ignition switch when you insert the key.

If the system repeatedly does not recognize the coding of your key, contact your dealer.

Do not attempt to alter this system or add other devices to it. Electrical problems could result that may make your vehicle inoperable.

If you have lost your key and cannot start your engine, contact your dealer.

NOTICE

Always take the ignition key with you whenever you leave the vehicle alone.

As required by the FCC:

This device complies with Part 15 of the FCC rules. Operation is subject to the following two conditions: (1) This device may not cause harmful interference, and (2) this device must accept any interference received, including interference that may cause undesired operation.

Changes or modifications not expressly approved by the party responsible for compliance could void the user's authority to operate the equipment.

This device complies with Industry Canada Standard RSS-210.

Operation is subject to the following two conditions: (1) this device may not cause interference, and (2) this device must accept any interference that may cause undesired operation of the device.

Ignition Switch

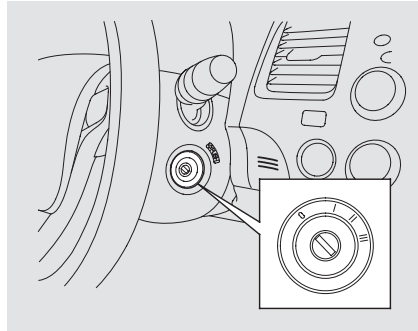

The ignition switch has four positions: LOCK (0), ACCESSORY (I), ON (II), and START (III).

LOCK (0) – You can insert or remove the key only in this position. To turn the key, push it in slightly. If your vehicle has an automatic transmission, the shift lever must also be in park.

If the front wheels are turned, the anti-theft lock may make it difficult to turn the key. Firmly turn the steering wheel to the left or right as you turn the key.

ACCESSORY (I) – You can operate the audio system and the accessory power sockets in this position.

ON (II) – This is the normal key position when driving. Several of the indicators on the instrument panel come on as a test when you turn the ignition switch from the ACCESSORY (I) to the ON (II) position.

START (III) – Use this position only to start the engine. The switch returns to the ON (II) position when you let go of the key.

CONTINUED

Ignition Switch, Door Locks

You will hear a reminder beeper if you leave the key in the ignition switch in the LOCK (0) or the ACCESSORY (I) position and open the driver's door. Remove the key to turn off the beeper.

If your vehicle has an automatic transmission, the shift lever must be in Park before you can remove the key from the ignition switch.

⚠ WARNING

Removing the key from the ignition switch while driving locks the steering. This can cause you to lose control of the vehicle.

Remove the key from the ignition switch only when parked.

Door Locks

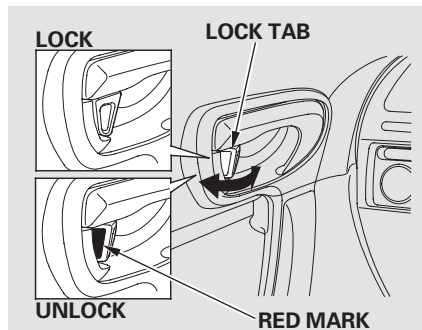

Each door has a lock tab next to the inside door handle. Pull out the tab to lock the door, and push it in to unlock.

When the door is unlocked, the red mark on the lock tab is shown.

On DX model except Canadian DX-G
To lock the passenger's door when getting out of the vehicle, pull out the lock tab and close the door. To lock the driver's door, pull and hold the outside door handle then pull out the lock tab. Release the handle, then close the door.

Each door can be locked or unlocked with the ignition key.

Power Door Locks

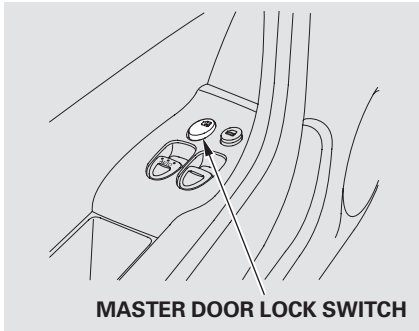

On LX, EX, EX-L and Si models in the U.S., and DX-G, SE, EX-L and Si models in Canada

To lock the doors, push the top of the master door lock switch on either door, pull out the lock tab on the driver's door, or use the key in the outside lock on the driver's door.

Pushing the bottom of either master door lock switch unlocks both doors.

The lock tab on the passenger's door locks and unlocks only that door. Pushing in the driver's door lock tab only unlocks the driver's door. To unlock only the driver's door from the outside, turn the key and release it. If you turn it again, both doors unlock.

To lock the passenger's door when getting out of the vehicle, pull out the lock tab and close the door. To lock the driver's door, remove the key from the ignition switch and pull out the lock tab or push the top of the master switch, then close the door.

Lockout Prevention

If you forget and leave the key in the ignition switch, lockout prevention will not allow you to lock the driver's door. With either door open and the key in the ignition switch, locking with the master door lock switch is disabled. If the driver's door is closed, the lock tab on the driver's door is not disabled. Pulling the driver's lock tab rearward will lock both doors. If you try to lock an open driver's door by pulling the lock tab rearward, the driver's door lock tab pops out and unlocks the driver's door.

Door Locks

Auto Door Locking/Unlocking

On LX, EX, EX-L and Si models in the U.S., and DX-G, SE, EX-L and Si models in Canada

Your vehicle has customizable settings for the doors to automatically lock and unlock. There are default settings for each of these features. You can turn off or change the settings for these features as described on the following pages.

When you customize the setting, make sure your vehicle is parked safely, the engine is off, and the parking brake is applied. Make all settings before you start driving.

Auto Door Locking

The auto door locking feature has three possible settings:

- The auto door locking is deactivated all the time.
- The doors lock whenever you move the shift lever out of the Park (P) position (A/T vehicles).
- The doors lock when the vehicle speed reaches 10 mph (15 km/h). This is the default setting.

To turn off the Auto Door Lock modes:

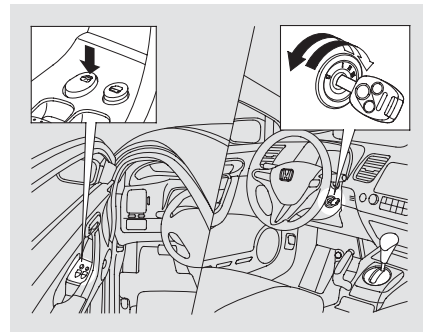

1. Make sure the shift lever is in the Park (P) position (A/T vehicles).
2. Turn the ignition switch to the ON (II) position, and open the driver's door.

3. Push and hold the front of the master door lock switch on the driver's door until you hear a click (after about 5 seconds).
4. Release the switch, and within 5 seconds, turn the ignition switch to the LOCK (0) position.

To program the Park Lock mode:

Locks both doors when the shift lever is moved out of the Park (P) position (A/T vehicles only).

1. Make sure the shift lever is in the Park (P) position.
2. Turn the ignition switch to the ON (II) position, and make sure to close the driver's door.

3. Push and hold the front of the master door lock switch on the driver's door. You will hear a click. Keep holding the switch until you hear another click (after about 5 seconds).
4. Release the switch, and within 5 seconds, turn the ignition switch to the LOCK (0) position.

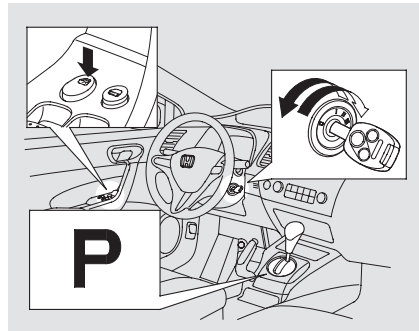

To program the Drive Lock mode:

Locks both doors when the vehicle's speed reaches about 10 mph (15 km/h).

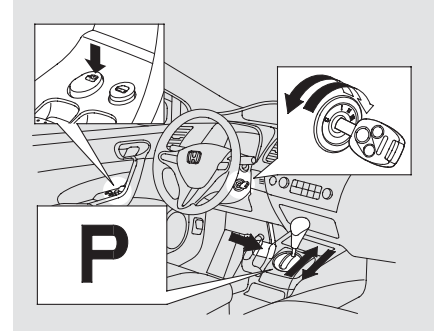

1. Make sure the shift lever is in the Park (P) position (A/T vehicles).
2. Turn the ignition switch to the ON (II) position, and make sure to close the driver's door.

CONTINUED

Door Locks

3. *On A/T vehicles*, push and hold the brake pedal, and move the shift lever out of the Park (P) position.
4. Push and hold the front of the master door lock switch on the driver's door. You will hear a click. Keep holding the switch until you hear another click (after about 5 seconds).
5. Release the switch, and within 5 seconds, turn the ignition switch to the ACCESSORY (I) position. *On A/T vehicles*, move the shift lever to the Park (P) position.
6. Turn the ignition switch to the LOCK (0) position.

Auto Door Unlocking

The auto door unlocking feature has five possible settings:

- The auto door unlocking is deactivated all the time.
- *On A/T vehicles*, the driver's door unlocks when you move the shift lever to the Park (P) position with the brake pedal depressed. This is the default setting.
- Both doors unlock when you move the shift lever to the Park (P) position with the brake pedal depressed (A/T vehicles).

- The driver's door unlocks whenever you turn the ignition switch to the ACCESSORY (I) position. This is the default setting on M/T vehicles.
- Both doors unlock whenever you turn the ignition switch to the ACCESSORY (I) position.

To turn off the Auto Door Unlock modes:

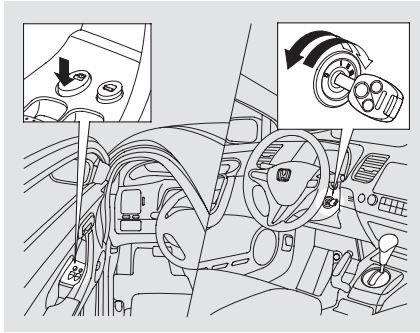

1. Make sure the shift lever is in the Park (P) position (A/T vehicles).
2. Turn the ignition switch to the ON (II) position, and open the driver's door.

3. Push and hold the rear of the master door lock switch on the driver's door. You will hear a click, and after about 5 seconds, you will hear another click.
4. Release the switch, and within 5 seconds, turn the ignition switch to the LOCK (0) position.

To program the Park Unlock mode: *Unlocks the driver's door or both doors when the shift lever is moved into the Park (P) position with the brake pedal depressed (A/T vehicles only).*

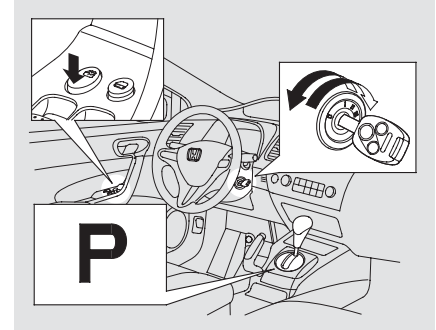

1. Make sure the shift lever is in the Park (P) position.
2. Turn the ignition switch to the ON (II) position, and make sure to close the driver's door.

CONTINUED

Door Locks

3. Push and hold the rear of the master door lock switch on the driver's door. You will hear a click. Continue to hold the switch:

- Until you hear another click (after about 5 seconds) to activate *driver's door unlock feature*.
- Or, until you hear two more clicks (after about 10 seconds) to activate *both doors unlock feature*.

4. Release the switch, and within 5 seconds, turn the ignition switch to the LOCK (0) position.

To program the Ignition Switch

Unlock mode:

Unlocks the driver's door or both doors when the ignition switch is moved out of the ON (II) position.

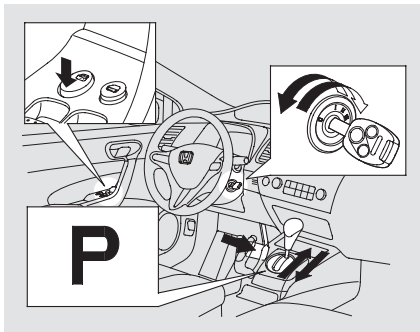

1. Make sure the shift lever is in the Park (P) position (A/T vehicles).
2. Turn the ignition switch to the ON (II) position, and make sure to close the driver's door.

3. *On A/T vehicles*, push and hold the brake pedal, then move the shift lever out of the Park (P) position.

4. Push and hold the rear of the master door lock switch on the driver's door. You will hear a click. Continue to hold the switch:

- Until you hear another click (after about 5 seconds) to activate *driver's door unlock feature*.
- Or, until you hear two more clicks (after about 10 seconds) to activate *both doors unlock feature*.

5. Release the switch, and within 5 seconds, turn the ignition switch to the ACCESSORY (I) position. *On A/T vehicles*, move the shift lever to the Park (P) position.
6. Turn the ignition switch to the LOCK (0) position.

Even if your vehicle's battery is removed or goes dead, the system keeps the auto door lock/unlock setting which you selected.

Remote Transmitter

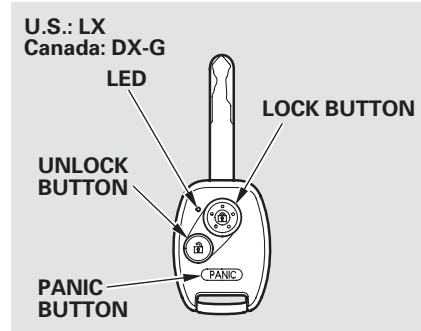

U.S.: LX, EX, EX-L, Si

Canada: DX-G, SE, EX-L, Si

LOCK — Press this button once to lock both doors. Some exterior lights will flash once. When you push LOCK twice within 5 seconds, you will hear a beep to verify that the doors are locked and that the security system (if equipped) has set. You cannot lock the doors if either door is not fully closed or the key is in the ignition switch.

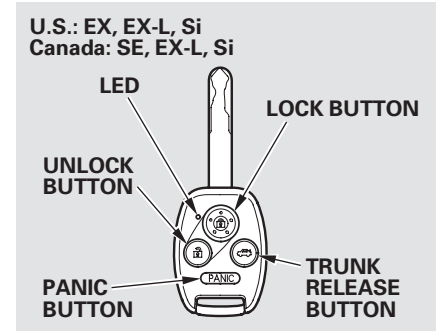

UNLOCK — Press this button once to unlock the driver's door. Push it twice to unlock the passenger's door. Some exterior lights will flash twice each time you push the button.

CONTINUED

Remote Transmitter

The ceiling light and the door activated spotlights (if equipped) come on when you press the UNLOCK button if the lights are in the door activated position. If you do not open either door within 30 seconds, the light(s) will fade out. If you relock the doors with the remote transmitter before 30 seconds have elapsed, the light(s) will go off immediately.

If you do not open either door within 30 seconds, the doors automatically relock, and the security system (if equipped) sets. You cannot unlock it if the key is in the ignition switch.

EX, EX-L, Si and Canadian SE models

TRUNK RELEASE — Press this button for about 1 second to open the trunk. You cannot open the trunk if the key is in the ignition switch.

PANIC — Press and hold this button for about 2 seconds to attract attention: the horn will sound and the exterior lights will flash for about 30 seconds. To cancel panic mode, press any other button on the remote transmitter, or turn the ignition switch to the ON (II) position.

Remote Transmitter Care

- Avoid dropping or throwing the transmitter.
- Protect the transmitter from extreme temperature.
- Do not immerse the transmitter in any liquid.
- If you lose a transmitter, the replacement needs to be reprogrammed by your dealer.

Replacing the Transmitter Battery

If it takes several pushes on the button to lock or unlock the doors, replace the battery as soon as possible.

Battery type: CR1616

To replace the battery:

1. Remove the screw at the base of the transmitter with a small Phillips-head screwdriver.

NOTE: Be careful when removing this screw as the head of the screw can strip out.

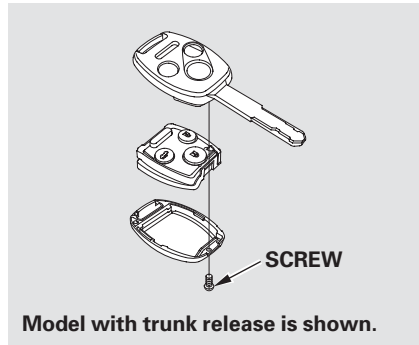

2. Separate the transmitter by prying its middle seam with your fingernail.

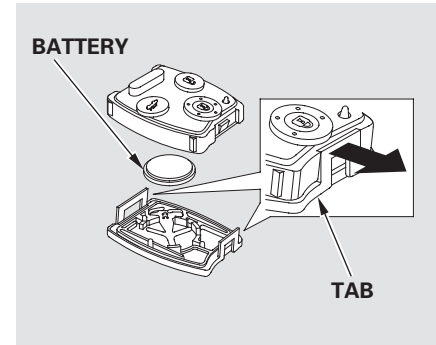

3. Inside the transmitter, separate the inner cover from the keypad by releasing the two tabs on the cover.

CONTINUED

Remote Transmitter

4. Remove the old battery from the back of the inner cover, and insert a new battery into the back of the cover with the + side facing down.

An improperly disposed of battery can hurt the environment. Always confirm local regulations for battery disposal.

5. Install the parts in reverse order.

As required by the FCC:

This device complies with Part 15 of the FCC rules. Operation is subject to the following two conditions: (1) This device may not cause harmful interference, and (2) this device must accept any interference received, including interference that may cause undesired operation.

Changes or modifications not expressly approved by the party responsible for compliance could void the user's authority to operate the equipment.

This device complies with Industry Canada Standard RSS-210.

Operation is subject to the following two conditions: (1) this device may not cause interference, and (2) this device must accept any interference that may cause undesired operation of the device.

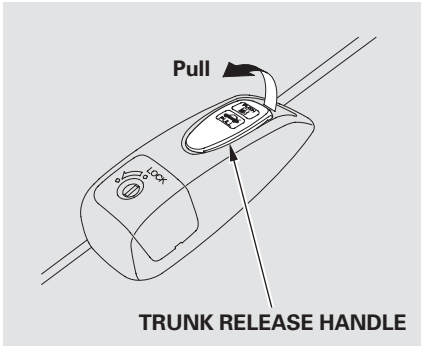

You can open the trunk in two ways:

- Pull the trunk release handle to the left of the driver's seat.
- *On EX, EX-L, Si and Canadian SE models*
Press and hold the trunk release button on the remote transmitter.

U.S. DX and LX, Canadian DX-G

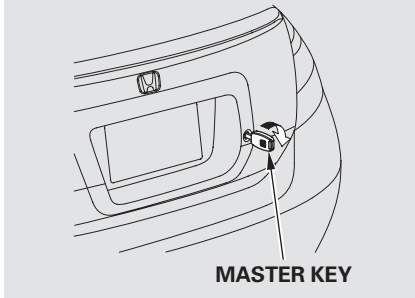

- *On U.S. DX and LX models, and Canadian DX-G model*
Use the master key to open the trunk lock. The valet key does not work in this lock.

To close the trunk, press down on the trunk lid.

Keep the trunk lid closed at all times while driving to avoid damaging the lid, and to prevent exhaust gas from getting into the interior. See **Carbon Monoxide Hazard** on page 52 .

CONTINUED

Trunk

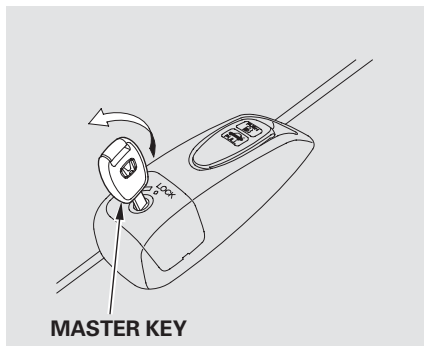

To protect items in the trunk when you need to give the key to someone else:

1. Lock the trunk release handle with the master key.
2. Give the person the valet key.

On EX, EX-L, Si and Canadian SE
Even if the trunk release lever is locked with the master key, you can open the trunk with the remote transmitter.

Emergency Trunk Opener

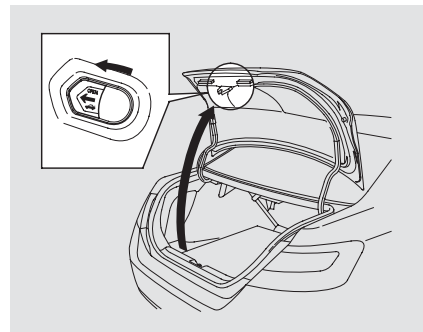

As a safety feature, your vehicle has a release lever on the trunk latch so the trunk can be opened from the inside.

To open the trunk, push the release lever in the direction indicated by the arrow.

Parents should decide if their children should be shown how to use this feature. For more information about child safety, see page 36 .

Front Seat Adjustments

See pages 11 – 13 for important safety information and warnings about how to properly position the seats and seat-backs.

Make all seat adjustments before you start driving.

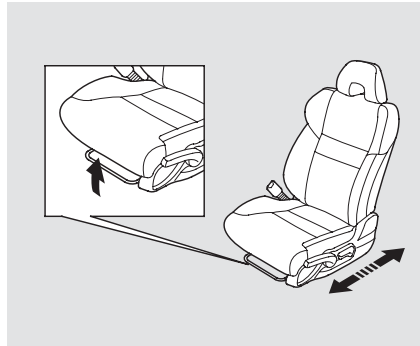

To adjust the seat forward or backward, pull up on the bar under the seat cushion's front edge. Move the seat to the desired position, and release the bar. Try to move the seat to make sure it is locked in position.

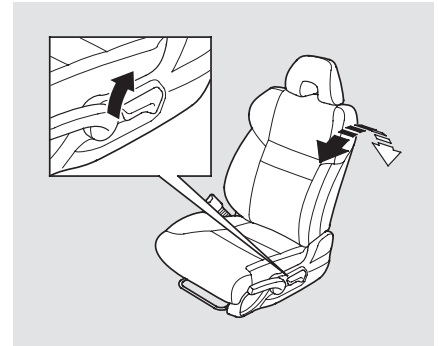

To change the seat-back angle, pull up on the lever on the outside of the seat bottom.

Once a seat is adjusted correctly, rock it back and forth to make sure it is locked in position.

Seats

Driver's Seat Height Adjustment

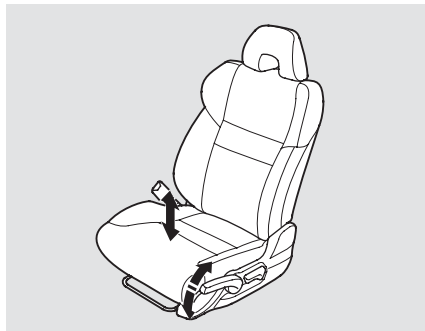

The height of your driver's seat is adjustable. To raise the seat bottom, repeatedly pull up the lever on the outside of the seat cushion. To lower the seat, push the lever down repeatedly.

Make all seat adjustments before you start driving.

Armrest

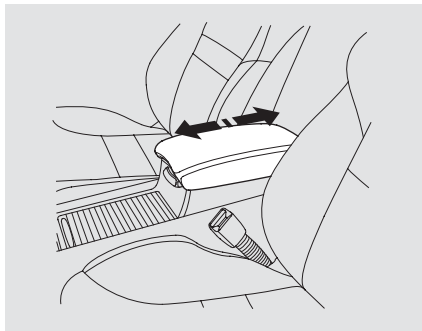

On all models except U.S. DX
To use the console lid as an armrest, slide it to one of its three positions.

Rear Seat Access

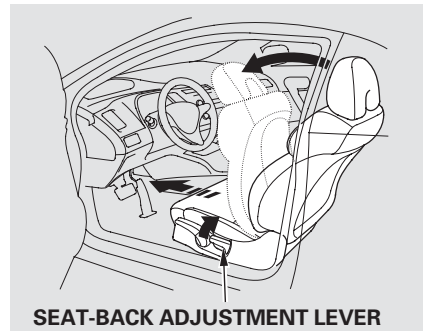

SEAT-BACK ADJUSTMENT LEVER

Driver's Side

To get into the rear seat on the driver's side, open the door and pull up on the seat-back adjustment lever. The seat-back will tilt forward to allow easier entry to the rear seat.

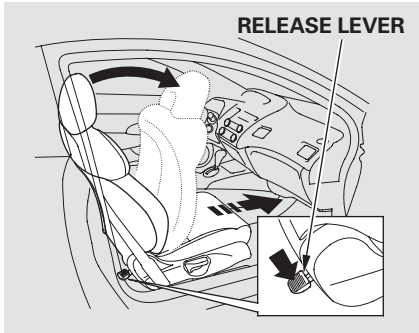
Passenger's Side

To get into the rear seat on the passenger's side, push downward on the release lever at the base of the seat-back or pull up on the seat-back adjustment lever. The seat-back will tilt forward to allow easier entry to the rear seat.

Except U.S. DX

When you push down the release lever or pull up the adjustment lever, the seat will also move forward. After a passenger gets into the back seat, push the seat-back to the upright position, and push the seat backwards until it latches. Make sure the seat is fully latched before sitting in it.

Seats

Head Restraints

See page 13 for important safety information and a warning about improperly positioning head restraints.

Your vehicle is equipped with head restraints in all seating positions to help protect you and your passengers from the likelihood of whiplash and other injuries.

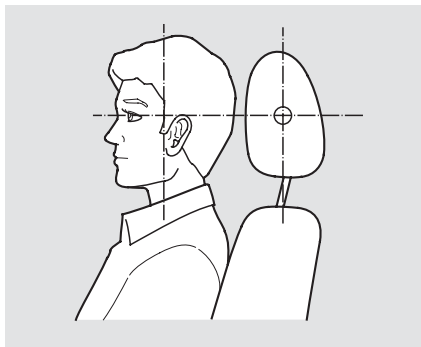

They are most effective when you adjust them so the center of the back of the occupant's head rests against the center of the restraint.

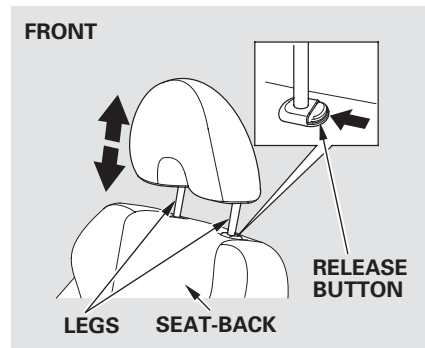

Adjusting the Head Restraint

The head restraints adjust for height. You need both hands to adjust a restraint. Do not attempt to adjust it while driving. To raise it, pull upward. To lower the restraint, push the release button sideways, and push the restraint down.

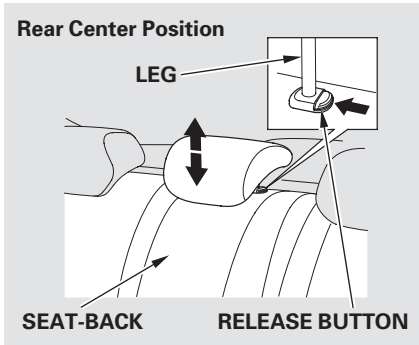

When a passenger is seated in the rear center seating position, the center head restraint should be adjusted up or down, to match the passenger's height.

Removing the Head Restraint

To remove a front or rear center head restraint for cleaning or repair, pull it up as far as it will go. Push the release button, then pull the restraint out of the seat-back.

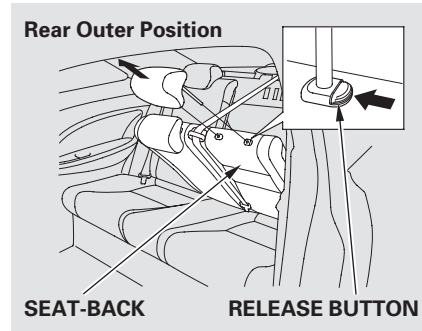

To remove a rear outer head restraint, do as follows.

1. Unlock the seat-back from inside the trunk by pulling the release (see page 102), then fold it forward slightly to make a space

between the rear window and the head restraint.

2. Pull the restraint up as far as it will go, push the release button, then pull the restraint out of the seat-back.
3. Push the seat-back firmly against the trunk panel to lock it upright.

⚠ WARNING

Failure to reinstall the head restraints can result in severe injury during a crash.

Always replace the head restraints before driving.

CONTINUED

Seats

When reinstalling a head restraint, put the legs back in place. Then adjust it to the appropriate height while pressing the release button.

Make sure the head restraint locks in position when you reinstall it.

When reinstalling the rear outer head restraints, also follow the step 1 of the removing procedure. Make sure to lock the seat-back upright after reinstalling the head restraints.

Active Head Restraints

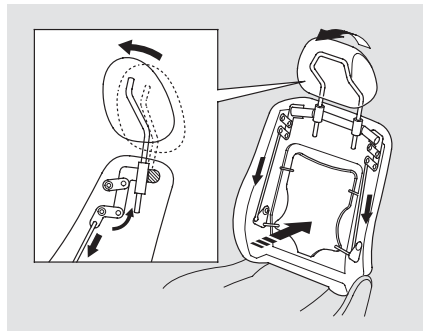

The driver's and front passenger's seats have active head restraints. If the vehicle is struck severely from the rear, the occupant properly secured with the seat belt will be pushed against the seat-back and the head restraint will automatically move forward.

This reduces the distance between the restraint and the occupant's head. It also helps protect the occupants against the likelihood of whiplash and injuries to the neck and upper spine.

After a collision, the activated restraint should return to its normal position.

If the restraints do not return to their normal position, or in the event of a severe collision, have the vehicle inspected by a Honda dealer.

For a head restraint system to work properly:

- Do not hang any items on the head restraints, or from the restraint legs.
- Do not place any object between an occupant and the seat-back.
- Install each restraint in its proper location.
- Only use genuine Honda replacement head restraints.

Folding Rear Seat

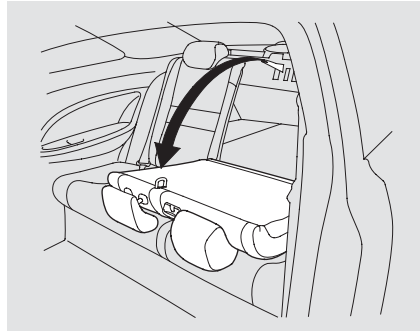

The back of the rear seat folds down to give you direct access to the trunk. The seat-back can be released from inside the trunk.

On all models except DX, Canadian DX-G and U.S. LX
The left and right halves can be folded separately.

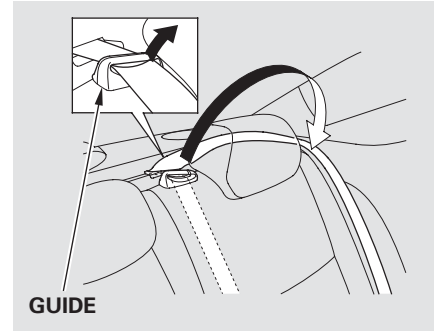

When storing cargo, you can move the rear center shoulder belt out of the way by removing the belt from the guide.

Remove any items from the seat before you fold down the seat-back.

CONTINUED

Seats

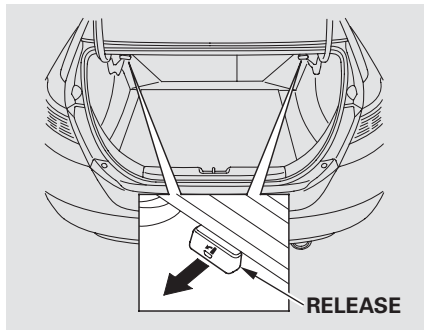

To release the seat-back, pull the release under the trunk panel. Push the seat-back down, then let go of the release.

For 60/40 split rear fold-down seat models, a release is located on each side of the trunk.

For full rear fold-down seat models, the release is located on the driver's side of the trunk.

Make sure that the folded seat-back does not press against the front passenger's seat, as this could cause the weight sensors to work improperly.

If the rear head restraints get caught on the front seat backs and you cannot fold down the rear seat-back fully, you can remove the head restraints (see page 99). Make sure the removed head restraints are securely stored.

To lock the seat-back upright, push it firmly against the trunk panel. Make sure it is latched in place by pulling on the top of the seat.

Make sure all rear shoulder belts are positioned in front of the rear seat-back, and the center shoulder belt is re-positioned in the guide whenever the seat-back is in its upright position. Be sure there are no twists in any shoulder belt.

Do not put any heavy items on the seat-back when it is folded down.

Make sure all items in the trunk, or items extending through the opening into the back seat, are secured.

Loose items can fly forward and cause injury if you have to brake hard. See **Carrying Cargo** on page 263 .

Never drive with the seat-back folded down and the trunk lid open. See **Carbon Monoxide Hazard** on page 52 .

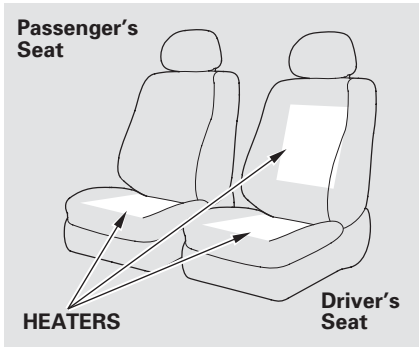

If equipped

Both front seats are equipped with seat heaters. Because of the sensors for the side airbag cutoff system, there is no heater in the passenger's seat-back. The ignition switch must be in the ON (II) position to use the heaters.

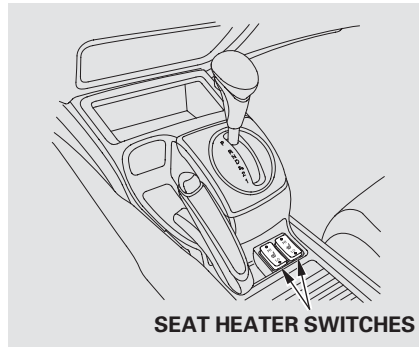

Push the front of the switch, HI, to rapidly heat up the seat. After the seat reaches a comfortable temperature, select LO by pushing the back of the switch. This will keep the seat warm.

In the HI setting, the heater turns off when the seat gets warm, and turns back on after the seat's temperature drops.

In the LO setting, the heater runs continuously. It does not cycle with temperature changes.

Follow these precautions whenever you use the seat heaters:

- Use the HI setting only to heat the seats quickly, because it draws large amounts of current from the battery.
- If the engine is left idling for an extended period, do not use the seat heaters even on the LO setting. It can weaken the battery, causing hard starting.

Power Windows

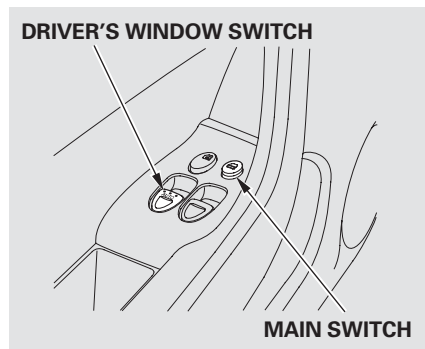

Turn the ignition switch to the ON (II) position to raise or lower either window. To open a window, push the switch down and hold it. Release the switch when you want the window to stop. Pull back on the switch and hold it to close the window.

⚠ WARNING

Closing a power window on someone's hands or fingers can cause serious injury.

Make sure your passengers are away from the windows before closing them.

The driver's armrest has a master power window control panel. To open the passenger's window, push down on the switch and hold it down until the window reaches the desired position. To close the window, pull back on the window switch. Release the switch when the window gets to the position you want.

Except DX and Canadian DX-G
AUTO — To open the driver's window fully, push the window switch firmly down, then release it. The window automatically goes down all the way. To stop the window from going all the way down, pull back on the window switch briefly.

To close the driver's window fully, pull back the window switch firmly, then release it. The window automatically goes all the way up. To stop the window from going all the way up, push down on the window switch briefly.

To open or close the driver's window partially, push down or pull back on the window switch lightly and hold it. The window will stop when you release the switch.

All models

When you push the MAIN switch in, the switch is OFF, and the passenger's window cannot be raised or lowered. To cancel this feature, push on the switch again to get it to pop out. Keep the MAIN switch off when you have children in the vehicle so they do not injure themselves by operating the window unintentionally.

The windows operate for up to 10 minutes after you turn off the ignition switch. Opening either door cancels this function.

Except DX and Canadian DX-G

AUTO REVERSE – If the driver's window runs into any obstacle while it is closing automatically, it will reverse direction, and then stop. To close the window, remove the obstacle, then use the window switch again.

Auto reverse stops sensing when the window is almost closed. You should always check that all passengers and objects are away from the window before closing it.

NOTE: The driver's window auto reverse function is disabled when you continuously pull up the switch.

If your vehicle's battery is disconnected or goes dead, or the driver's window fuse is removed, the AUTO function could be disabled. If the power window system needs to be reset after reconnecting the battery or installing the fuse, do this:

1. Start the engine. Push down and hold the driver's window switch until the window is fully open.
2. Pull and hold the driver's window switch to close the window completely, then hold the switch for about 2 seconds.

If the power windows do not operate properly after resetting, have your vehicle checked by your dealer.

Moonroof

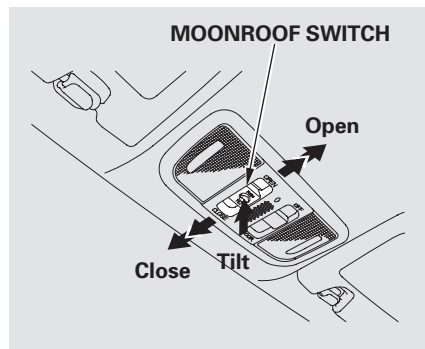

If equipped

The moonroof can be tilted up in the back for ventilation, or it can be slid back into the roof. Use the switch on the front ceiling to operate the moonroof. You must turn the ignition switch to the ON (II) position to operate the moonroof.

To tilt up the moonroof, push on the center of the moonroof switch. To stop the moonroof from tilting up fully, push the switch briefly.

To open the moonroof, pull back on the switch and hold it. Release the switch when the moonroof reaches the desired position. To close the moonroof, push the switch forward and hold it. Release the switch to stop the operation.

⚠ WARNING

Opening or closing the moonroof on someone's hands or fingers can cause serious injury.

Make sure all hands and fingers are clear of the moonroof before opening or closing it.

AUTO — To open the moonroof fully, pull back the moonroof switch firmly, then release it. The moonroof automatically opens all the way. To stop the moonroof from opening, push the switch briefly.

To close the moonroof fully, firmly push the moonroof switch forward, then release it. The moonroof automatically closes all the way. To stop the moonroof from closing, push the switch briefly.

To open or close the moonroof partially, lightly pull the switch back or push it forward and hold it. The moonroof will stop when you release the switch.

AUTO REVERSE – If the moonroof runs into any obstacle while it is closing automatically, it will reverse direction and then stop. To close the moonroof, remove the obstacle, then use the moonroof switch again.

Auto reverse stops sensing when the moonroof is almost closed. You should always check that all passengers and objects are away from the moonroof before closing it.

The moonroof has a key-off delay. You can open and close the moonroof for up to 10 minutes after you turn off the ignition switch. The key-off delay cancels as soon as you open either door.

NOTICE

If you try to open the moonroof in below-freezing temperatures, or when it is covered with snow or ice, you can damage the moonroof panel or motor.

Mirrors

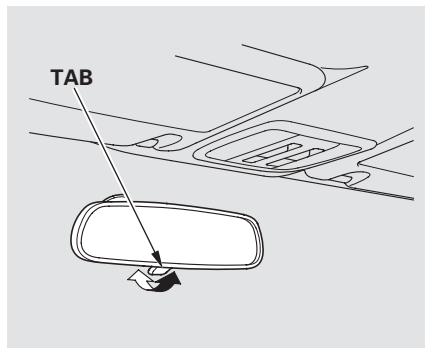

Keep the inside and outside mirrors clean and adjusted for best visibility. Be sure to adjust the mirrors before you start driving.

The inside mirror has day and night positions. The night position reduces glare from headlights behind you. Flip the tab on the bottom edge of the mirror to select the day or night position.

Adjusting the Power Mirrors

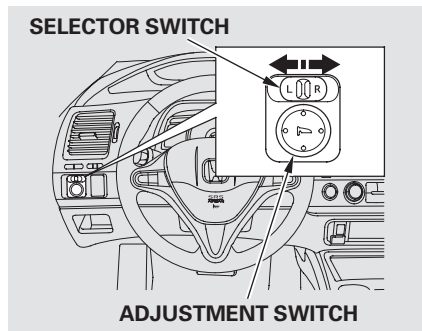

If equipped

1. Turn the ignition switch to the ON (II) position.
2. Move the selector switch to L (driver's side) or R (passenger's side).
3. Push the appropriate edge of the adjustment switch to move the mirror right, left, up, or down.
4. When you finish, move the selector switch to the center (off) position. This turns the adjustment switch off to keep your settings.

Power Mirror Heaters

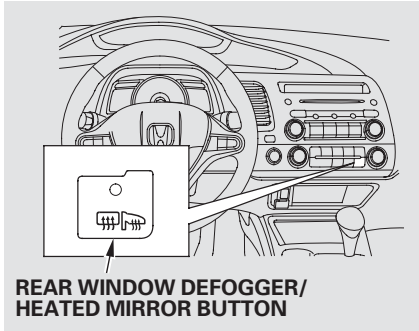

*EX-L model in the U.S.
SE, EX-L and Si models in Canada*
The outside mirrors are heated to remove fog and frost. With the ignition switch in the ON (II) position, turn on the heaters by pressing the rear window defogger button. The indicator in the button comes on as a reminder. Press the button again to turn the heaters and the defogger off.

Parking Brake

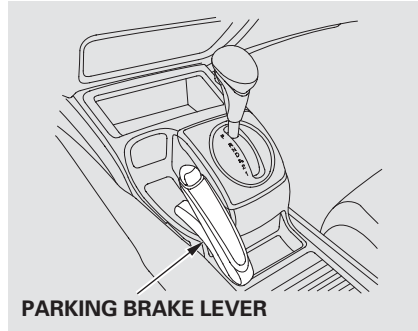

To apply the parking brake, pull the lever up fully. To release it, pull up slightly, push the button, and lower the lever. The parking brake indicator on the instrument panel should go out when the parking brake is fully released (see page 60).

NOTICE

Driving the vehicle with the parking brake applied can damage the rear brakes and hubs. A beeper will sound if the vehicle is driven with the parking brake on.

Interior Convenience Items

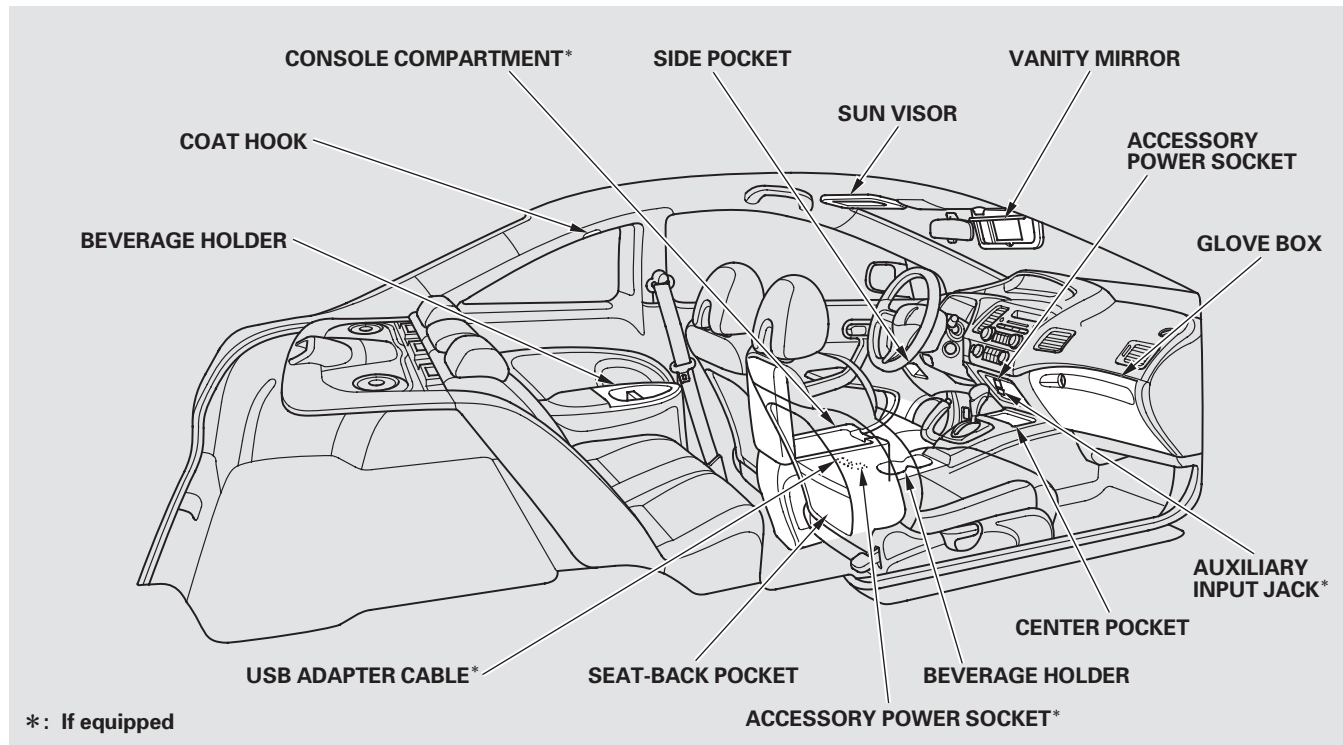

Beverage Holders

Be careful when you are using the beverage holders. A spilled liquid that is very hot can scald you or your passengers. Spilled liquids can damage the upholstery, carpeting, and electrical components in the interior.

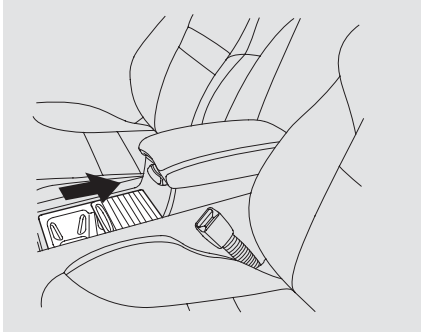

Open the front beverage holder by sliding the lid.

Console Compartment

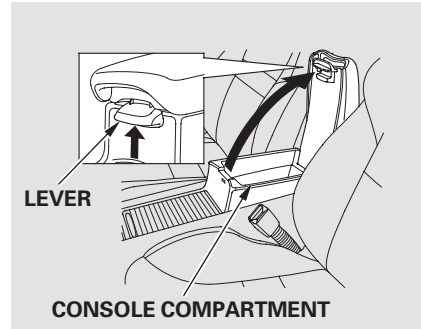

If equipped

To open the console compartment, pull up on the lever, and lift the lid.

To close, lower the lid, and push it down until it latches.

Glove Box

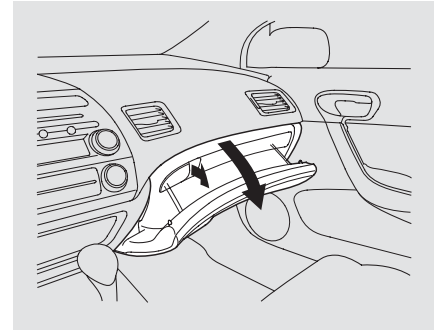

Open the glove box by pulling the handle to the left. Close it with a firm push.

CONTINUED

Interior Convenience Items

⚠ WARNING

An open glove box can cause serious injury to your passenger in a crash, even if the passenger is wearing the seat belt.

Always keep the glove box closed while driving.

Coat Hook

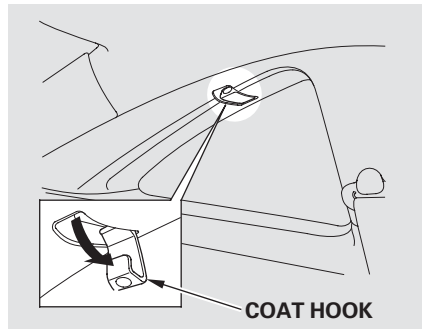

To use a coat hook, pull it down. Close it with a firm push.

Make sure the coat hook is closed when you are not using it. This hook is not designed for large or heavy items.

Accessory Power Sockets

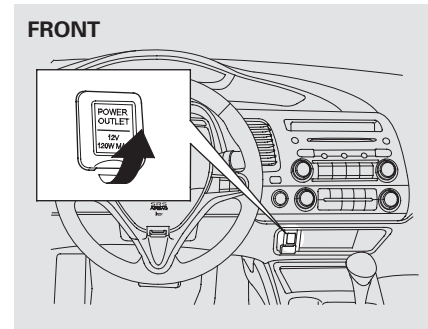

To use an accessory power socket, pull up the cover.

This socket is intended to supply power for 12 volt DC accessories that are rated 120 watts or less (10 amps).

To use an accessory power socket, the ignition switch must be in the ACCESSORY (I) or ON (II) position.

CONSOLE COMPARTMENT

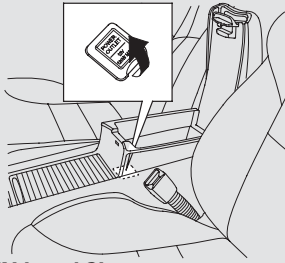

EX, EX-L and Si

On EX, EX-L and Si models without navigation system

Another accessory power socket is in the center console compartment.

None of the sockets will power an automotive type cigarette lighter element. When both sockets are being used, the combined power rating of the accessories should be 120 watts or less (10 amps).

Make sure to put the socket cover back in place to prevent any small foreign objects from getting into the socket.

Vanity Mirror

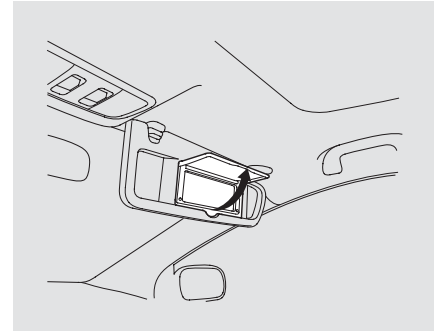

To use the vanity mirror on the back of the sun visor, pull up the cover.

Interior Convenience Items, Interior Lights

Sun Visor

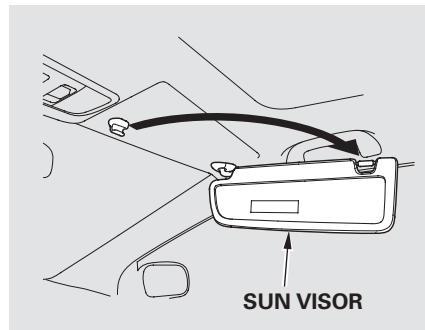

To use the sun visor, pull it down. When using the sun visor for the side window, remove the support rod from the clip, and swing it out.

Make sure you put the sun visor back in place when you are getting into or out of the vehicle.

Ceiling Light

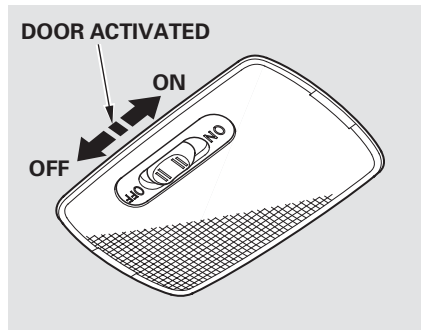

The ceiling light has a three-position switch: ON, Door Activated, and OFF. In the Door Activated (center) position, the light comes on when you:

- Open either door.
- Unlock the doors with the key or the remote transmitter.

After both doors are closed tightly, the light dims slightly, then fades out in about 30 seconds.

The ceiling light (with the switch in the center position) comes on when you remove the key from the ignition switch. If you do not open a door, the light stays on, then fades out in about 30 seconds.

If you leave either door open without the key in the ignition switch, the ceiling light goes off after 3 minutes.

Spotlights

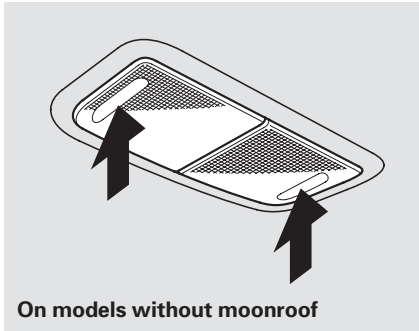

If equipped

Turn on a spotlight by pushing the lens. Push the lens again to turn it off. You can use the spotlights at all times.

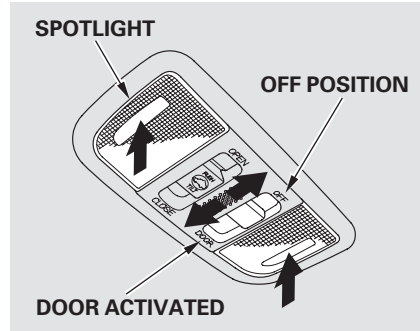

On models with moonroof

The spotlights have a two-position switch. In the DOOR position, the lights come on when you open either door. In the OFF position, the lights do not come on.

The spotlights (with the switch in the DOOR position) also come on when you unlock the door with the key or the remote transmitter, and when you remove the key from the ignition switch.

Interior Lights

Courtesy Light

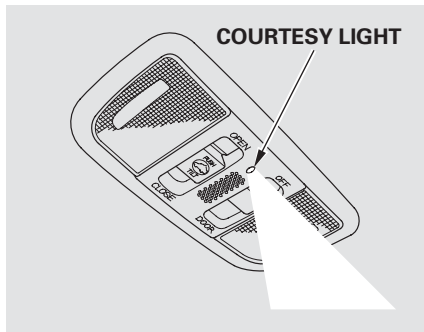

If equipped

The courtesy light between the spotlights comes on when you turn the parking lights on. To adjust its brightness, push the instrument panel brightness control buttons under the driver's side vent with the ignition switch in the ON (II) position.

The heating and air conditioning* systems in your vehicle provide a comfortable driving environment in all weather conditions.

*Air conditioning is optional on DX model.

The standard audio system has many features. This section describes those features and how to use them. (If you have an optional audio system, refer to the operating instructions that came with it.)

If equipped

Your vehicle has an anti-theft audio system that requires a code number to enable it.

U.S. LX, EX, EX-L and Si models

The security system helps to discourage vandalism and theft of your vehicle.

Navigation systems are optional on U.S. EX, EX-L and Si models only.

Vents, Heating, and A/C	118
Audio System	123
Audio System (Models without navigation system)	124
Playing the AM/FM Radio.....	125
Adjusting the Sound	128
Playing the XM® Radio (Optional)	129
Playing a Disc.....	134
Disc Player Error Messages	140
Optional Disc Changer Error Messages	141
Playing an iPod®	142
iPod® Error Messages	150
Playing a USB Flash Memory Device	151
USB Flash Memory Device Error Messages	158
Audio System (Models with navigation system)	159
Voice Control System.....	159
Playing the AM/FM Radio.....	160
Playing the XM® Radio	163
Adjusting the Sound	170
Playing a Disc.....	172
Disc Player Error Messages	180

Playing a PC Card.....	181
PC Card Error Messages.....	193
Playing an iPod®	194
iPod® Error Messages	203
Playing a USB Flash Memory Device	204
USB Flash Memory Device Error Messages	213
AM/FM Radio Reception.....	214
Protecting Your Discs.....	216
Remote Audio Controls.....	219
Auxiliary Input Jack.....	220
Radio Theft Protection.....	221
Setting the Clock	222
Security System	223
Cruise Control.....	224
Bluetooth® HandsFreeLink®	227

Vents, Heating, and A/C

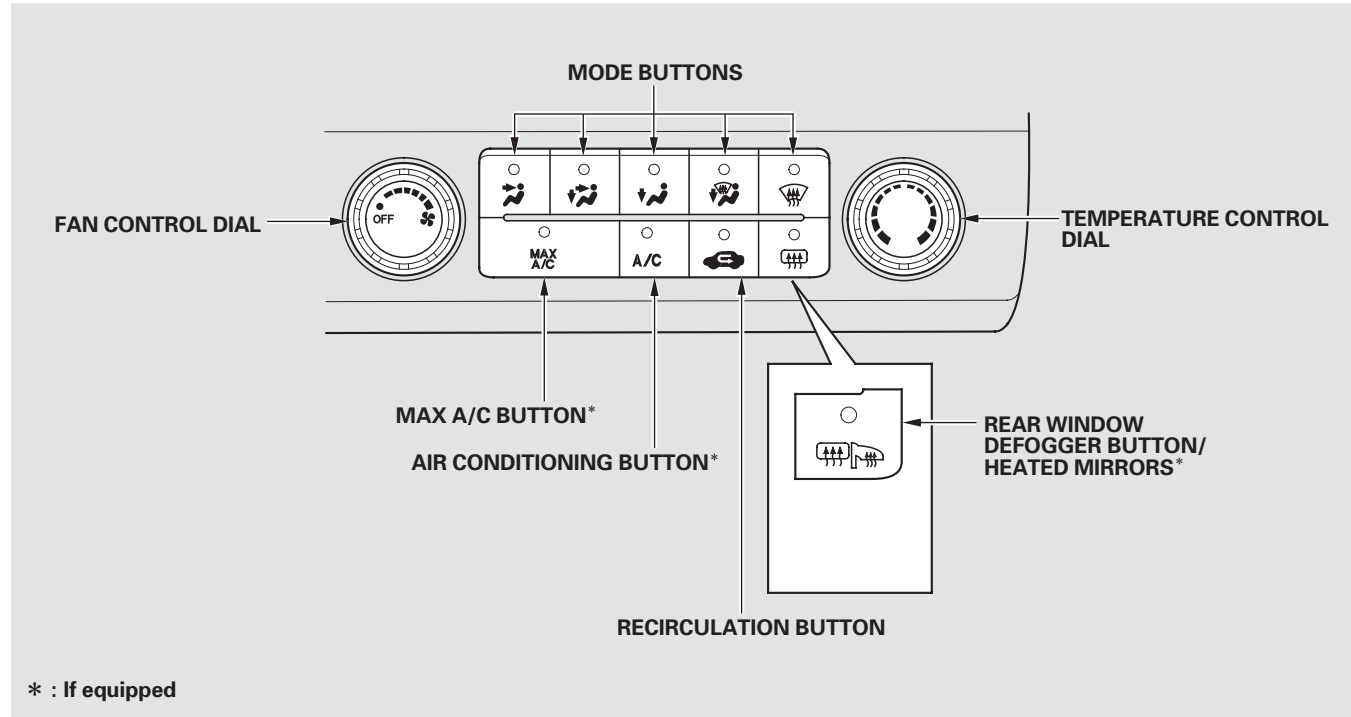

Fan Control Dial

Turn this dial to increase or decrease the fan speed and airflow.

Temperature Control Dial

Turning this dial clockwise increases the temperature of the airflow.



Air Conditioning (A/C) Button

If equipped

This button turns the air conditioning on and off. The indicator in the button is on when the A/C is on.

MAX A/C Button

If equipped

 The system automatically turns on the A/C and switches to recirculation mode (see page 121 to use this setting). Air flows from the center and side vents in the dashboard. Pressing the , A/C, or any of the mode buttons cancels MAX A/C, but the A/C stays on.

Recirculation Button

When the recirculation indicator is on, air from the vehicle's interior is sent throughout the system again. When the indicator is off, air is brought in from the outside of the vehicle (fresh air mode).

The outside air intakes for the heating and cooling system are at the base of the windshield. Keep this area clear of leaves and other debris.

The system should be left in fresh air mode under almost all conditions. Keeping the system in recirculation mode, particularly with the A/C off, can cause the windows to fog up.

Switch to recirculation mode when driving through dusty or smoky conditions, then return to fresh air mode.

Rear Window Defogger Button

This button turns the rear window defogger off and on (see page 77).

On some models, this button also operates the heated outside mirrors (see page 109).

Mode Control

Use the mode control buttons to select the vents air flows from. Some air will flow from the dashboard corner vents in all modes.





 Air flows from the center and corner vents in the dashboard.

 Airflow is divided between the vents in the dashboard and the floor vents.



CONTINUED

Vents, Heating, and A/C

 Air flows from the floor vents.



When you select , the system automatically switches to fresh air mode. If you switch the mode from  or  to , the system keeps the A/C on. The A/C indicator will not come on if it was off to start with.

To turn off the A/C, press the A/C button to illuminate the indicator, then press it again to turn off the A/C.

When you switch to  or  mode from , the A/C turns off. But if it was on to start with, the A/C stays on.

 Airflow is divided between the floor vents and defroster vents at the base of the windshield.

 Air flows from the defroster vents at the base of the windshield.

When you select  or , the system automatically switches to fresh air mode and turns on the A/C. You cannot turn the A/C off in this mode.





Ventilation

The ventilation system draws in outside air, circulates it through the interior, then releases it through vents near the rear window.

1. Set the temperature to the lower limit.
2. Make sure the A/C is off.
3. Select  and fresh air mode.
4. Set the fan to the desired speed.

Using the Heater

The heater uses engine coolant to warm the air. If the engine is cold, it will be several minutes before you feel warm air coming from the system.

1. Select  .
When you select , the system automatically switches to fresh air mode. If you switch the mode from  or , the system also automatically turns on the A/C. This helps prevent the windows from fogging up unintentionally. The A/C indicator will not come on if it was off to start with (see the first column on this page).
2. Set the fan to the desired speed.
3. Adjust the warmth of the air with the temperature control dial.

Using the A/C

Air conditioning places an extra load on the engine. Watch the engine coolant temperature gauge (see page 70). If it moves near the red zone, turn off the A/C until the gauge reading returns to normal.

1. Turn on the A/C by pressing the button. The indicator in the button comes on when a fan speed is selected.
2. Make sure the temperature is set to maximum cool.
3. Select .
4. If the outside air is humid, select recirculation mode. If the outside air is dry, select fresh air mode.
5. Set the fan to the desired speed.

If the interior is very warm, you can cool it down more rapidly by partially opening the windows, turning on the air conditioning, and setting the fan to maximum speed in fresh air mode.

To cool the interior with MAX A/C:

1. Set the fan to the desired speed.
2. Select MAX A/C.

The system automatically turns on the A/C, selects , and switches to recirculation mode.

3. Make sure the temperature is set to maximum cool.

Dehumidify the Interior

Air conditioning, as it cools, removes moisture from the air. When used in combination with the heater, it makes the interior warm and dry and can prevent the windows from fogging up.



1. Turn the fan on.
2. Turn on the air conditioning.
3. Select  and fresh air mode.
4. Adjust the temperature to your preference.



This setting is suitable for all driving conditions whenever the outside temperature is above 32°F (0°C).

Vents, Heating, and A/C



To Defog and Defrost

To remove fog from the inside of the windows:

1. Set the fan to the desired speed, or high for faster defrosting.
2. Select . The system automatically switches to fresh air mode and turns on the A/C. The A/C indicator will not come on if it was off to start with.
3. Adjust the temperature so the airflow feels warm.
4. Select / to help clear the rear window.
5. To increase airflow to the windshield, close the corner vents.

When you switch to , from  or , the A/C stays on. This helps prevent the windows from rapidly fogging up when the air is suddenly routed away from the windshield. If you want to turn the A/C off, press and release the A/C button twice. The indicator in the button comes on and then goes off.

To Remove Exterior Frost or Ice From the Windows

1. Select . The system automatically switches to fresh air mode and turns on the A/C. The A/C indicator does not come on if it was off to start with.
2. Select .
3. Set the fan and temperature controls to maximum level.

To clear the windows faster, you can close the dashboard corner vents by rotating the wheel next to each vent. This sends more warm air to the windshield defroster vents. Once the windshield is clear, select fresh air mode to avoid fogging the windows.

For your safety, make sure you have a clear view through all the windows before driving.

To Turn Everything Off

Turning the fan speed control dial all the way to the left shuts the system off.

- Keep the system off for short periods only.
- To keep stale air and mustiness from collecting, you should have the fan running at all times.

An audio system is standard on all models except the U.S. DX. Read the appropriate pages (as shown below) to use your vehicle's audio system.

For vehicles without navigation system, see pages 124 through 158.

For vehicles with navigation system, see pages 159 through 213.

Models without navigation system
U.S. LX model
Canadian DX-G and SE models
Optional for U.S. DX model

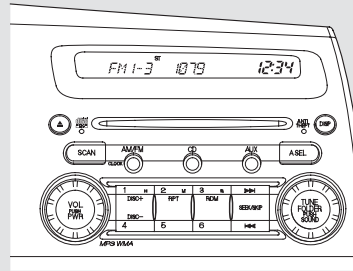

EX, EX-L and Si models

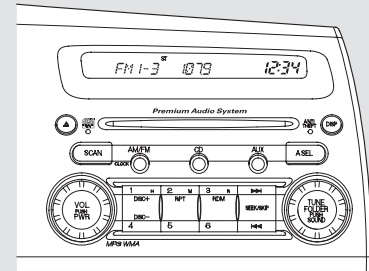

Models with navigation system
U.S. EX, EX-L and Si models

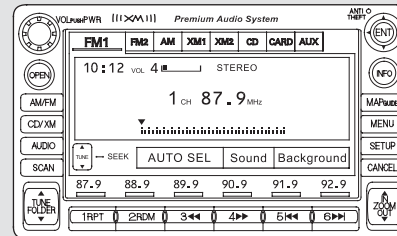

Audio System (Models without navigation system)

Your audio system shows a welcome message on the display when you turn the ignition switch to the ACCESSORY (I) or the ON (II) position.

You can also customize this welcome message to your liking with the audio controls.

To Customize a Message

You can set up to 16 characters on the display.

To select a character:

1. Make sure the audio system is off.
2. Push and hold the TUNE knob, then push the power/volume knob on the audio control panel. You will see the first letter blinking.

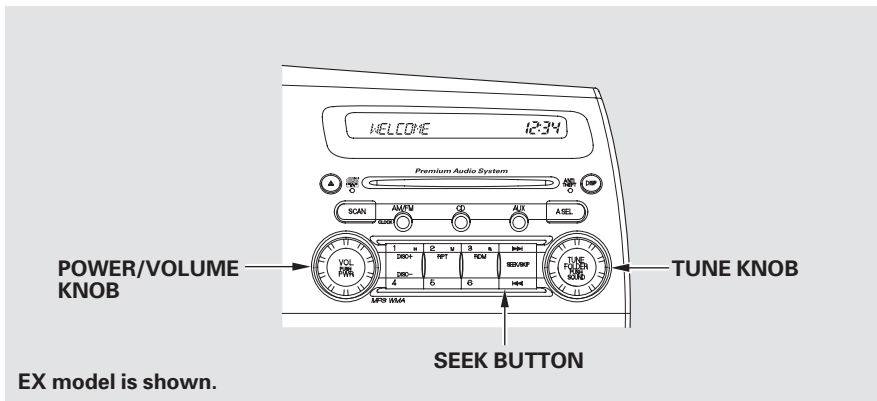

3. Turn the TUNE knob to change a letter.
4. Push the top of the SEEK button to select the next segment, then turn the TUNE knob to select a letter. Repeat this procedure to set your message.

To change the letter, select the previous segment by pushing the bottom of the SEEK button.

The system will return to the audio display about 10 seconds after you stop selecting a letter.

Playing the AM/FM Radio (Models without navigation system)

U.S. LX and Canadian DX-G and SE models
Optional for U.S. DX model

EX, EX-L and Si models

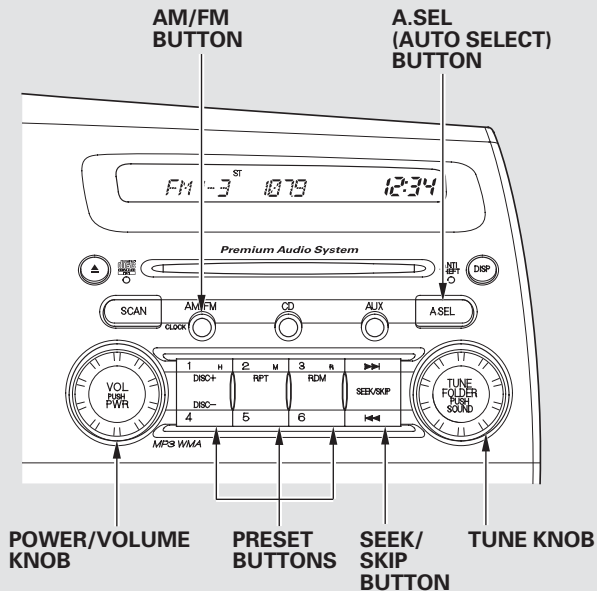
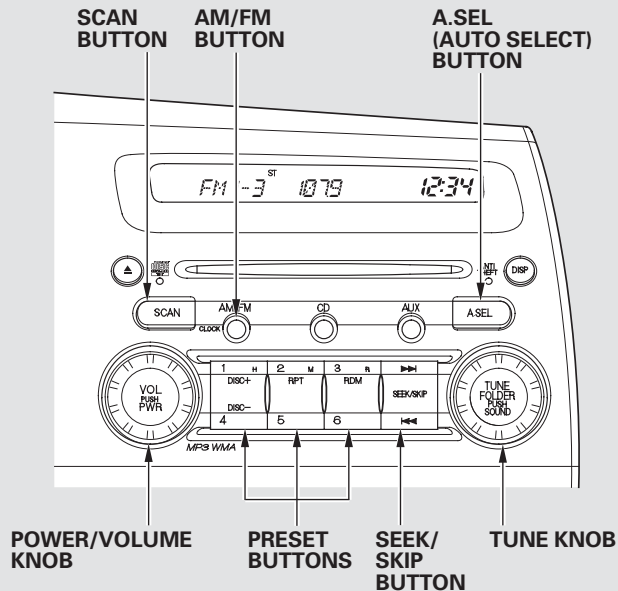

Playing the AM/FM Radio (Models without navigation system)

To Play the AM/FM Radio

The ignition switch must be in the ACCESSORY (I) or ON (II) position. Turn the system on by pushing the power/volume knob or the AM/FM button. Adjust the volume by turning the power/volume knob.

The band and frequency that the radio was last tuned to is displayed. To change bands, press the AM/FM button. On the FM band, ST will be displayed if the station is broadcasting in stereo. Stereo reproduction in AM is not available.

To Select a Station

You can use any of five methods to find radio stations on the selected band: tune, seek, scan, the preset buttons, and auto select.

TUNE — Use the TUNE knob to tune the radio to a desired frequency. Turn the knob to the right to tune to a higher frequency, and turn it to the left to tune to a lower frequency.

SEEK — The seek function searches up and down from the current frequency to find a station with a strong signal. To activate it, press the ◀◀ or ▶▶ side of the SEEK/SKIP button, then release it.

SCAN — The scan function samples all stations with strong signals on the selected band. To activate it, press the SCAN button, then release it. You will see SCAN in the display. When the system finds a strong signal, it will stop and play that station for about 10 seconds.

If you do nothing, the system will then scan for the next strong station and play it for 10 seconds. When it plays a station you want to listen to, press the SCAN button again.

Playing the AM/FM Radio (Models without navigation system)

Preset — Each side of the buttons (1 through 6) can store one frequency on AM, and two frequencies on FM.

1. Select the desired band, AM or FM. FM1 and FM2 let you store six stations each.
2. Use the tune, seek, or scan function to tune the radio to a desired station.
3. Pick a preset number (1–6), and hold it until you hear a beep.
4. Repeat steps 1 through 3 to store a total of six stations on AM and twelve stations on FM.

AUTO SELECT — If you are traveling and can no longer receive your preset stations, you can use the auto select feature to find stations in the local area.

Press the A. SEL button. You will see A. SEL flashing in the display, and the system goes into scan mode for several seconds. It stores the frequencies of six AM, and twelve FM stations in the preset buttons.

You will see a “0” displayed after pressing a preset button if auto select cannot find a strong station for every preset button.

If you do not like the stations auto select has stored, you can store other frequencies on the preset buttons as previously described.

To turn off auto select, press the A. SEL (auto select) button. This restores the presets you originally set.

For information on AM/FM radio frequencies and reception, see page 214 .

Adjusting the Sound (Models without navigation system)

Press the TUNE (SOUND) knob repeatedly to display the SUBW (if equipped), BASS, TREBLE, FADER, BALANCE, and SVC (speed-sensitive volume compensation) settings.

If equipped

SUBW — Adjusts the strength of sound from the subwoofer speaker.

BASS — Adjusts the bass.

TREBLE — Adjusts the treble.

FADER — Adjusts the front-to-back strength of the sound.

BALANCE — Adjusts the side-to-side strength of the sound.

SVC — Adjusts the volume level based on the vehicle speed.

Each mode is shown in the display as it changes. Turn the TUNE knob to adjust the setting to your liking. When the level reaches the center, you will see “C” in the display.

The system will return to the audio display about 5 seconds after you stop adjusting a mode.

Speed-sensitive Volume Compensation (SVC)

The SVC mode controls the volume based on vehicle speed. The faster you go, the louder the audio volume becomes. As you slow down, the audio volume decreases.

The SVC has four modes: SVC OFF, SVC LOW, SVC MID, and SVC HIGH. Turn the TUNE knob to adjust the setting to your liking. If you feel the sound is too loud,

choose low. If you feel the sound is too quiet, choose high.

Audio System Lighting

You can use the instrument panel brightness control buttons to adjust the illumination of the audio system (see page 76). The audio system illuminates when the parking lights are on, even if the radio is off.

Playing the XM® Radio (Models without navigation system)

Optional on U.S. EX, EX-L and Si models

Your audio system is capable of receiving XM® Radio anywhere in the United States, except Hawaii, Alaska, and Puerto Rico.

XM is a registered trademark of Sirius XM Radio®, Inc.

XM Radio receives signals from two satellites to produce clear, high-quality digital reception. It offers many channels in several categories. Along with a large selection of different types of music, XM Radio allows you to view channel and category selections in the display.

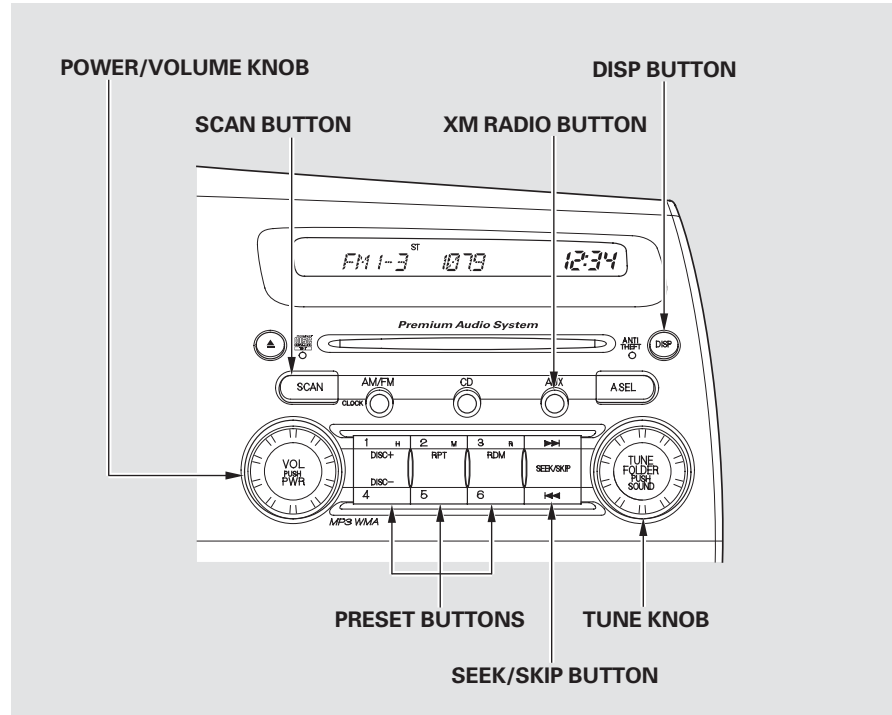

Playing the XM[®] Radio (Models without navigation system)

Operating the XM Radio

To listen to XM Radio, turn the ignition switch to the ACCESSORY (I) or the ON (II) position. Press the AUX button to select XM Radio mode. Adjust the volume by turning the knob. The last channel you listened to will show in the display.

MODE — To switch between channel mode and category mode, press and hold the DISP button until the mode changes.

In channel mode, you can select all of the available channels. In category mode, such as Jazz, Rock, Classical, etc., you can select all of the channels within that category.

Each time you press and release the DISP button, the display changes in the following sequence: Channel name, channel number, category, artist name, and music title.

You may experience periods when XM Radio does not transmit the artist's name and song title information. If this happens, there is nothing wrong with your system.

TUNE — Turn the TUNE knob to change channel selections. Turn the knob right for higher numbered channels and left for lower numbered channels. In the category mode, you can only select channels within that category.

SEEK/SKIP (CATEGORY) — Press either side of the SEEK/SKIP button (◀◀ or ▶▶) to select another category.

Playing the XM[®] Radio (Models without navigation system)

SCAN – The scan function gives you a sampling of all channels while in the channel mode. In the category mode, only the channels within that category are scanned. To activate scan, press the SCAN button. The system plays each channel in numerical order for a few seconds, then selects the next channel. When you hear a channel you want to continue listening to, press the button again.

Preset – You can store up to 12 preset channels using each side of the preset button. Each side of the button stores one channel from the XM1 band and one channel from the XM2 band.

To store a channel:

1. Press the AUX button. Either XM1 or XM2 will show in the display.

2. Use the tune, seek, or scan function to tune to a desired channel.

In category mode, only channels within that category can be selected. In channel mode, all channels can be selected.

3. Pick a preset number you want for that channel. Press and hold the button until you hear a beep.
4. Repeat steps 2 and 3 to store the first six channels.
5. Press the AUX button again. Store the next six channels using steps 2 and 3.

Once a channel is stored, press and release the proper side of the preset button to tune to it.

XM Radio Display Messages

“LOADING” – XM is loading the audio or program information.

“OFF AIR” – The channel currently selected is no longer broadcasting.

“UPDATING” – The encryption code is being updated. Wait until the encryption code is fully updated. Channels 0 and 1 should still work normally.

“NO SIGNAL” – The signal is currently too weak. Move the vehicle to an area away from tall buildings, and with an unobstructed view of the southern horizon.

CONTINUED

Playing the XM® Radio (Models without navigation system)

“----” – The selected channel number does not exist, or is not part of your subscription, or this channel has no artist or title information at this time.

“NO INFO” – The selected channel has no artist or title information at this time.

“ANTENNA” – There is a problem with the XM antenna. Please consult your dealer.

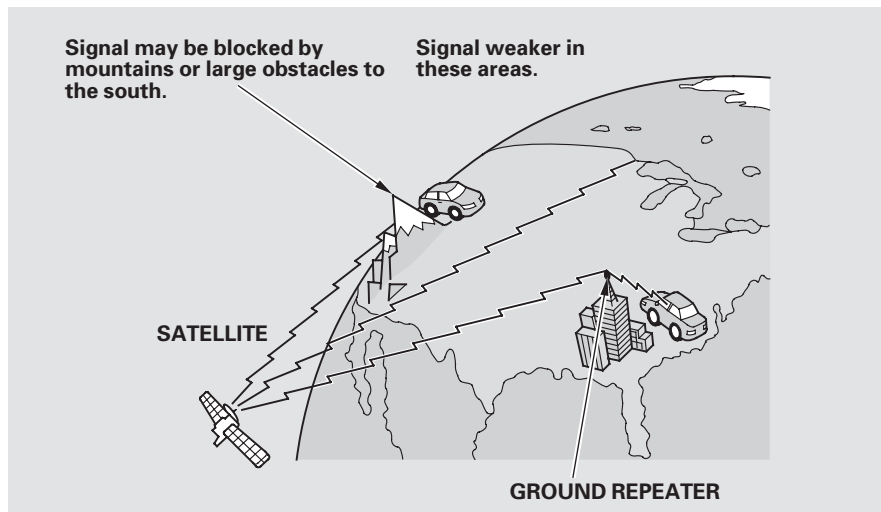

The XM satellites are in orbit over the equator; therefore, objects south of the vehicle may cause satellite reception interruptions. To help compensate for this, ground-based repeaters are placed in major metropolitan areas.

Satellite signals are more likely to be blocked by tall buildings and mountains the farther north you travel from the equator. Carrying large items on a roof rack can also block the signal.

Playing the XM® Radio (Models without navigation system)

Depending on where you drive, you may experience reception problems. Interference can be caused by any of these conditions:

- Driving on the north side of an east/west mountain road.
- Driving on the north side of a large commercial truck on an east/west road.
- Driving in tunnels.
- Driving on a road beside a vertical wall, steep cliff, or hill to the south of you.
- Driving on the lower level of a multi-tiered road.
- Driving on a single lane road alongside dense trees taller than 50 ft. (15 m) to the south of you.
- Large items carried on a roof rack.

There may be other geographic situations that could affect XM Radio reception.

*As required by the FCC:
Changes or modifications not expressly approved by the party responsible for compliance could void the user's authority to operate the equipment.*

Receiving XM Radio Service

If your XM Radio service has expired or you purchased your vehicle from a previous owner, you can listen to a sampling of the broadcasts available on XM Radio. With the ignition switch in the ACCESSORY (I) or ON (II) position, push the power/volume knob to turn on the audio system and press the AUX button. A variety of music types and styles will play.

If you decide to purchase XM Radio service, contact XM Radio at www.xmradio.com, or at 1-800-852-9696. You will need to give them your radio I.D. number and your credit card number. To get your radio I.D. number, turn the TUNE knob until "0" appears in the display.

Your I.D. will appear in the display.

After you've registered with XM Radio, keep your audio system in the XM Radio mode while you wait for activation. This should take about 30 minutes.

While waiting for activation, make sure your vehicle remains in an open area with good reception. Once your audio system is activated, you'll be able to listen to XM Radio broadcasts. XM Radio will continue to send an activation signal to your vehicle for at least 12 hours from the activation request. If the service has not been activated after 36 hours, contact XM® Radio. In Canada, contact XM CANADA®.

Playing a Disc (Models without navigation system)

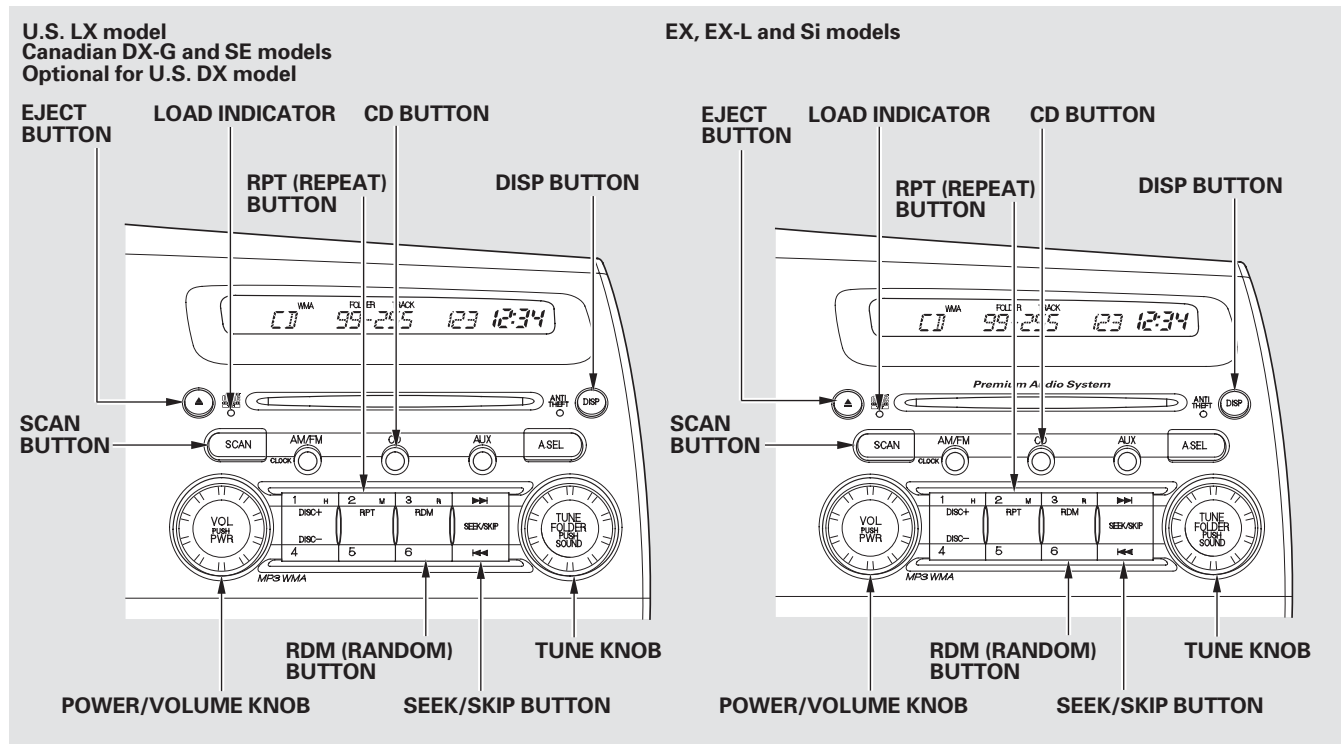

Playing a Disc (Models without navigation system)

To Play a Disc

To load or play discs, the ignition switch must be in the ACCESSORY (I) or ON (II) position.

You operate the disc player with the same controls used for the radio. To select the disc player, press the CD button. You will see “CD” in the display.

NOTICE

Do not use discs with adhesive labels. The label can curl up and cause the disc to jam in the unit.

This audio system can also play CD-Rs and CD-RWs compressed in MP3 or WMA formats. When playing a disc in MP3, you will see “MP3” in the display. In WMA format, “WMA” will appear in the display. You can select up to 255 folders or tracks.

Depending on the software the files were made with, it may not be possible to play some files, or display some text data.

NOTE:

If a file on WMA disc is protected by digital rights management (DRM), the audio unit displays CD FORMAT, and then skips to the next file.

Video CDs and DVDs do not work in this unit.

To Load a Disc

Insert a disc about halfway into the disc slot. The drive will pull the disc in the rest of the way to play it. You operate the disc player with the same controls used for the radio. The number of the current track and the elapsed time are shown in the display. When playing a disc in MP3 or WMA, the numbers of the current folder and file, and the elapsed time are shown. The system will continuously play a disc until you change modes.

You cannot load and play 3-inch (8-cm) discs in this system.

CONTINUED

Playing a Disc (Models without navigation system)

Text Data Display Function

Each time you press the DISP button, the display shows you the text data on a disc, if the disc was recorded with text data.

You can see the album, artist, and track name in the display. If a disc is recorded in MP3 or WMA, you can see the folder and file name, and the artist, album, and track tag.

With the folder name, you will see the FOLDER indicator in the display. The TRACK indicator is shown with the file or track name.

The display shows up to 16 characters of selected text data (the folder name, file name, etc.). If the text data has more than 16 characters, you will see the first 15 characters and the > indicator in the display. Press and hold the DISP button until the next 16 characters are shown.

If you press and hold the DISP button again, the display shows the first 15 characters again.

You will also see some text data under these conditions:

- When a new folder, file, or track is selected.
- When you change the audio mode to play a disc with text data or in MP3 or WMA.
- When you insert a disc, and the system begins to play.

When playing a CD-DA with text data, the album and track name are shown in the display. With a disc in MP3 or WMA, the display shows the folder and file name.

To Change or Select Tracks/Files

Use the SEEK/SKIP button while a disc is playing to select passages and change tracks (files in MP3/WMA mode).

SEEK/SKIP — Each time you press and release the ►► side of the SEEK/SKIP button, the player skips forward to the beginning of the next track (file in MP3 or WMA mode). Press and release the ◀◀ side to skip backward to the beginning of the current track. Press it again to skip to the beginning of the previous track.

To move rapidly within a track, press and hold the ►► or ◀◀ side of the SEEK/SKIP button.

Playing a Disc (Models without navigation system)

In MP3 or WMA mode

FOLDER SELECTION – To select a different folder, turn the TUNE knob to move to the beginning of the next folder. Turn the knob to the right until it clicks once to skip to the next folder, and to the left to move to the beginning of the previous folder. Turning the TUNE knob more than two clicks skips several folders.

REPEAT (TRACK/FILE

REPEAT) – To continuously replay a track (files in MP3 or WMA mode), press and release the RPT button. You will see “RPT” in the display. Press and hold the RPT button for 2 seconds to turn it off.

In MP3 or WMA mode

FOLDER-REPEAT – This feature, when activated, replays all files in the selected folder in the order they are compressed. To activate folder repeat, press the RPT button twice. You will see F-RPT in the display. The system continuously replays the current folder. Press the RPT button again to turn it off. Pressing the RDM button, or selecting a different folder with the TUNE knob also turns off the repeat feature.

Each time you press and release the RPT button, the mode changes from file repeat to folder repeat, then to normal play.

RANDOM (Random within a disc/folder) – This feature plays the tracks within a disc (the files within a folder in MP3 or WMA mode) in random order. To activate random play, press and release the RDM button. In MP3 or WMA mode, press the RDM button repeatedly to select RDM (within a folder random play). You will see RDM in the display. Press the RDM button for 2 seconds to return to normal play.

CONTINUED

Playing a Disc (Models without navigation system)

In MP3 or WMA mode

FOLDER-RANDOM – This feature, when activated, plays all files in the selected folder in random order. To activate folder random, press and release the RDM button. You will see F-RDM in the display. The system will then select and play files randomly. This continues until you deactivate folder random by pressing and holding the RDM button for 2 seconds, or by selecting a different folder with the TUNE knob.

Each time you press and release the RDM button, the mode changes from folder random play to random play (within a folder random play), then to normal play.

SCAN (TRACK/FILE SCAN) –

The scan function samples all tracks (files in MP3 or WMA) on the disc in the order they are recorded on the disc. To activate scan, press and release the SCAN button. You will see SCAN in the display. You will get a 10 second sampling of each track/file on the disc. Press and hold the SCAN button for about 2 seconds to get out of scan mode and play the last track/file sampled.

Pressing either side of the SEEK/SKIP button also turns off the scan feature.

In MP3 or WMA mode

F-SCAN (FOLDER SCAN) – This feature, when activated, samples the first file in each folder on the disc. To activate folder scan, press the SCAN button twice. You will see F-SCAN in the display.

The system plays the first file in the first folder for about 10 seconds. If you do nothing, the system will then play the first files in the next folders for 10 seconds. After playing the first file in the last folder, the system plays normally.

Pressing either side of the SEEK/SKIP button, selecting a different folder with the TUNE knob, or pressing the SCAN button, also turns off the folder scan.

Each time you press and release the SCAN button, the mode changes from file scan to folder scan, then to normal play.

Playing a Disc (Models without navigation system)

To Stop Playing a Disc

Press the eject button (▲) to remove the disc. If you eject the disc, but do not remove it from the slot, the system will automatically reload the disc after 10 seconds and put it in pause mode. To begin playing, press the CD button.

You can also eject the disc when the ignition switch is off.

To play the radio when a disc is playing, press the AM/FM button or AUX button on models that are XM Radio capable. Press the CD button again to switch back to the disc player.

You can also press the MODE button on the steering wheel to change modes.

To play an audio unit connected to the auxiliary input jack or the USB adapter cable when a disc is playing,

press the AUX button. Press the CD button again to switch back to the disc player.

If you turn the system off while a disc is playing, either with the power/volume knob or by turning off the ignition switch, the disc will stay in the drive. When you turn the system back on, the disc will begin playing where it left off.

Operating the Optional Disc Changer

An optional six or eight disc changer is available for your vehicle. This disc changer uses the same controls used for the in-dash disc player or the radio.

Load the desired discs in the magazine, and load the magazine in the changer according to the instructions that came with the unit.

To select the disc changer, press the CD button. The disc and track numbers will be displayed. To select a different disc, use the preset 4 button (DISC -) or the preset 1 button (DISC +). To select the previous disc, press the preset 4 button (DISC -), or the preset 1 button (DISC +) to select the next disc in sequence.

If you select an empty slot in the magazine, the changer will search for the next available disc to load and play.

Protecting Discs

For information on how to handle and protect compact discs, see page 216.

Disc Player Error Messages (Models without navigation system)

The chart on the right explains the error messages you may see in the display while playing a disc.

If you see an error message in the display while playing a disc, press the eject button. After ejecting the disc, check it for damage or deformation. If there is no damage, insert the disc again.

For additional information on damaged discs, see page 217 .

If there is still a problem, the error message will appear again. Press the eject button, and pull out the disc.

Insert a different disc. If the new disc plays, there is a problem with the first disc. If the error message cycle repeats and you cannot clear it, take your vehicle to a dealer.

Error Message	Cause	Solution
UNSUPPORT FORMAT	Track/File format not supported	Current track will be skipped. The next supported track or file plays automatically.
BAD DISC PLEASE CHECK OWNERS MANUAL PUSH EJECT	Mechanical Error	Press the eject button and pull out the disc(s). Check the disc for serious damage, signs of deformation, excessive scratches, and/or dirt (see page 217). Insert the disc again. If the code does not disappear, or the disc(s) cannot be removed, consult your dealer. Do not try to force the disc out of the player.
BAD DISC PLEASE CHECK OWNERS MANUAL	TOC Error FOCUS Error	

The ejected disc will not be reloaded automatically.

Optional Disc Changer Error Messages (Models without navigation system)

The chart on the right explains the error messages you may see in the display while playing a disc.

If you see an error message in the display while playing a disc, press the eject button. After ejecting the disc, check it for damage or deformation. If there is no damage, insert the disc again.

For additional information on damaged discs, see page 217 .

If there is still a problem, the error message will appear again. Press the eject button, and pull out the disc.

Insert a different disc. If the new disc plays, there is a problem with the first disc. If the error message cycle repeats and you cannot clear it, take your vehicle to a dealer.

Error Message	Cause	Solution
<i>CDC DISC ERROR</i>	FOCUS Error	Press the magazine eject button, and pull the magazine out. If the message does not disappear or the magazine cannot be pulled out, see your dealer.
<i>CDC NO DISC</i>	No disc in the disc magazine	Insert disc.
<i>CDC MECH ERROR</i>	Mechanical Error	Press the magazine eject button, pull the magazine out, check for an error message, then insert the magazine again. If the message does not disappear, or the magazine cannot be pulled out, see your dealer.
<i>CDC EJECT</i>	No disc magazine in the disc changer	Insert disc magazine.
<i>CDC HEAT ERROR</i>	High Temperature	Will disappear when the temperature returns to normal.

Playing an iPod® (Models without navigation system)

EX, EX-L, Si and Canadian SE models

Canadian SE model

EX, EX-L, and Si models

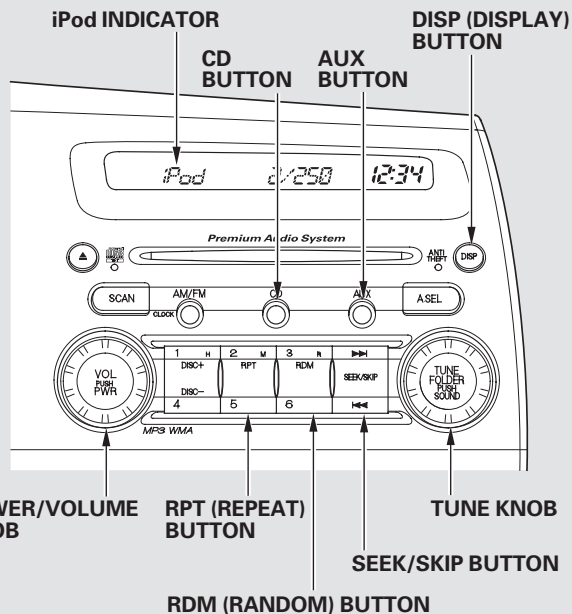
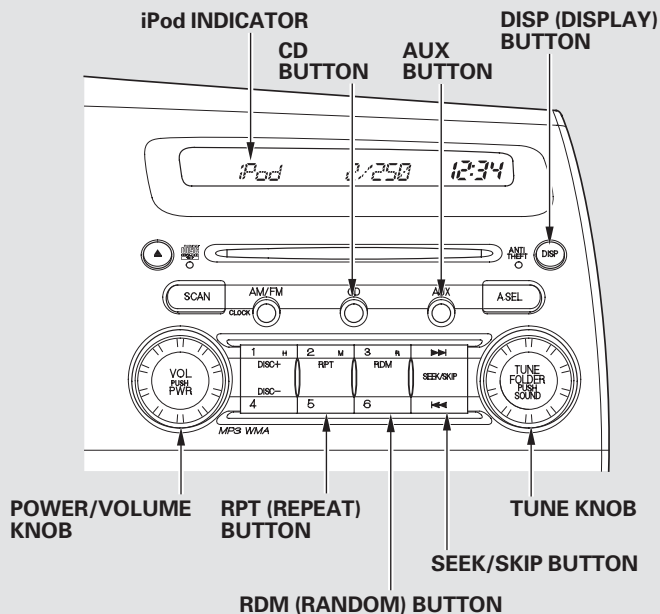

Playing an iPod® (Models without navigation system)

To Play an iPod®

This audio system can select and play the audio files on the iPod® with the same controls used for the disc player. To play an iPod, connect it to the USB adapter cable in the console compartment by using your dock connector, then press the AUX button. The ignition switch must be in the ACCESSORY (I) or ON (II) position. The iPod will also be charged with the ignition switch in these positions.

The audio system reads and plays playable sound files on the iPod. The system cannot operate an iPod as a mass storage device. The system will only play songs stored on the iPod with iTunes.

iPod and iTunes are registered trademarks owned by Apple Inc.

iPods compatible with your audio system using the USB adapter cable are:

Model	Software
iPod classic (80/160 G)	Ver. 1.1.2 or more
iPod classic (120 G)	Ver. 2.0.1 or more
iPod with video (iPod 5th generation)	Ver. 1.3.0 or more
iPod nano	Ver. 1.3.1 or more
iPod nano 2nd generation	Ver. 1.1.3 or more
iPod nano 3rd generation	Ver. 1.1.3 or more
iPod nano 4th generation	Ver. 1.0.3 or more
iPod nano 5th generation	Ver. 1.0.1 or more
iPod touch	Ver. 1.1.5 or more
iPod touch 2nd generation	Ver. 2.2.1 or more

Use only compatible iPods with the latest software. iPods that are not compatible will not work in this audio unit.

CONTINUED

Playing an iPod® (Models without navigation system)

NOTE:

- Do not connect your iPod using a hub.
- Do not keep the iPod in the vehicle. Direct sunlight and high heat will damage it.
- Do not use an extension cable between the USB adapter cable equipped with your vehicle and your dock connector.
- We recommend backing up your data before playing it.
- Some devices cannot be powered or charged via the USB adapter. If this is the case, use the accessory adapter to supply power to your device.

Connecting an iPod

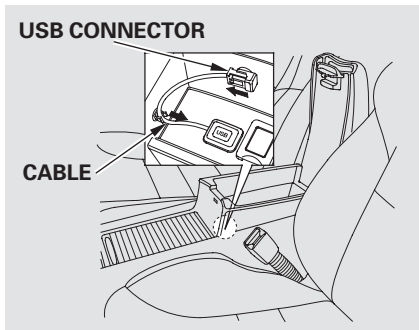

1. Pull out the USB connector from the holder and remove the cable from the clip in the console compartment.

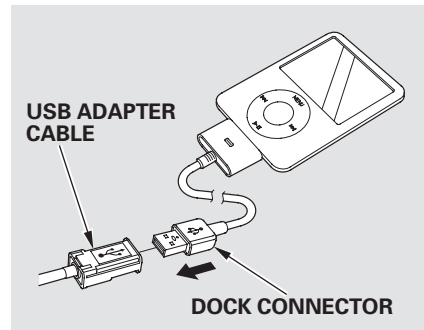

2. Connect your dock connector to the iPod correctly and securely.
3. Install the dock connector to the USB adapter cable securely.

Playing an iPod® (Models without navigation system)

If the iPod indicator does not appear in the audio display, check the connections, and try to reconnect the iPod a few times.

If the audio system still does not recognize the iPod, the iPod may need to be reset. Follow the instructions that came with your iPod, or you can find reset instructions online at www.apple.com/itunes/

Text Data Display Function

Each time you press the DISP button, the display mode switches between the album name, the song/track name, the artist name, or name off (which turns off the text display).

The display shows up to 16 characters of the selected data. If the text data has more than 17 characters, you will see the first 15 characters and the > indicator in the display. Press and hold the DISP button until the next 16 characters are shown.

If you press and hold the DISP button again, the display shows the first 15 characters again.

To Change or Select Files

You can use the SEEK/SKIP button while an iPod is playing to select passages and change files.

SKIP — Each time you press and release the ►►| side of the SEEK/SKIP button, the system skips forward to the beginning of the next file. Press and release the |◄◄ side of the button to skip backward to the beginning of the current file. Press it again to skip to the beginning of the previous file.

To move rapidly within a file, press and hold either side (►►| or |◄◄) of the SEEK/SKIP button.

CONTINUED

Playing an iPod® (Models without navigation system)

To Select a File from iPod Menu

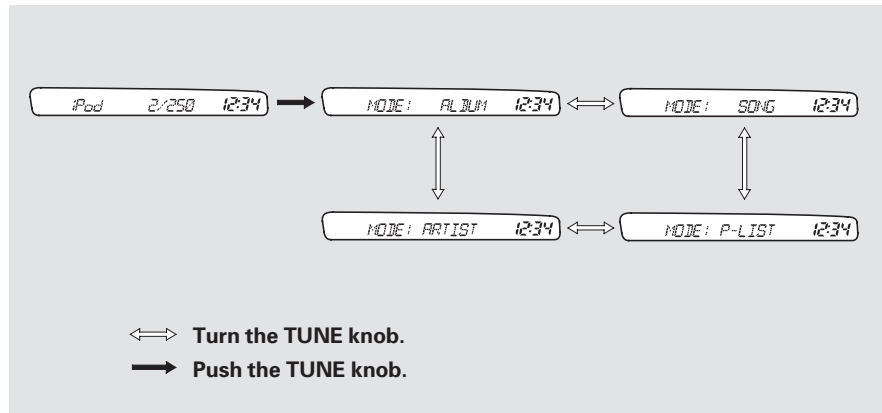

You can also select a file from the iPod menu: ALBUM (albums), SONG (songs), P-LIST (playlists), and ARTIST (artists), by using the TUNE knob. Push the TUNE (SOUND) knob to switch the display to an iPod menu, then turn the TUNE knob to select a desired mode. If you stop adjusting, the displayed

mode is selected after about five seconds. The system begins to play the first file stored in the selected mode.

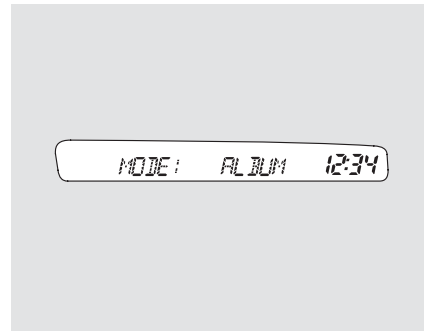

Selection within a Mode – Turn the TUNE knob to select a different item in the selected mode. The selected item will be shown on the display for a few seconds. When you stop turning, the system begins to play the first file from the selected item.

Playing an iPod® (Models without navigation system)

For example, with the album mode selected, turn the TUNE knob right or left to select a different album. Turn to the right to skip to the next album, and turn to the left to skip to the previous album. When the album is selected, the system begins to play the first song on that album. With the artist mode, turning the knob selects a different artist.

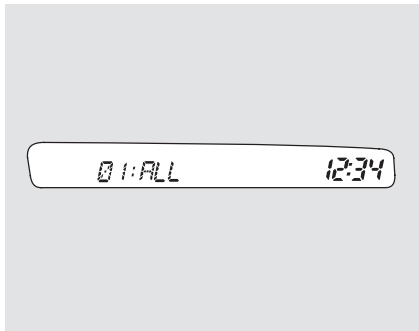

If you select “ALL,” all available files on the selected menu (album or artist) are played.

If you press and release the TUNE (SOUND) knob repeatedly, the display switches from the iPod menu to the sound settings (see page 128).

To Select Repeat or Random Mode: You can select any type of repeat and shuffle modes by using the RPT and RDM buttons.

RPT (Repeat one track) – This feature continuously plays a file. To activate repeat, press and release the RPT button. You will see RPT in the display. Press the button again to turn it off.

Pressing either side of the SEEK/SKIP button or turning the TUNE knob changes the file while keeping the repeat feature.

CONTINUED

Playing an iPod® (Models without navigation system)

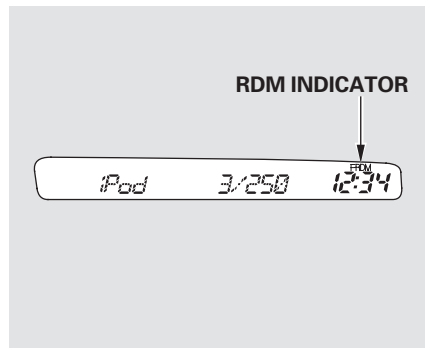

RDM (All Random) – This feature plays all available files in a selected mode (playlists, artists, albums or songs) in random order. To activate this, press and release the RDM button. You will see RDM in the display.

F-RDM (Album Random) – This feature plays all available albums in a selected mode (playlists, artists, albums or songs) in random order. The files in each album are played in the recorded order. To activate this, press and release the RDM button repeatedly until you see F-RDM in the display.

Each time you press and release the RDM button, the mode changes from all random, to album random, then to normal play.

Press and hold the button until you hear a beep to turn off either random mode.

Pressing either side of the SEEK/SKIP button or turning the TUNE knob changes a file while keeping the random function.

NOTE:

Available operating functions vary on models or versions. Some functions may not be available on the vehicle's audio system.

Playing an iPod® (Models without navigation system)

To Stop Playing Your iPod

To play the radio, press the AM/FM button. Press the CD button to switch to the disc mode (if a disc is loaded). Pressing the AUX button switches the audio mode between the USB and AUX.

You can also press the MODE button on the steering wheel to change modes.

Disconnecting an iPod

You can disconnect the iPod at any time when you see the “OK to disconnect” message* in the iPod display. With the AUX mode, you will see a “USB NO DATA” message in the display. Always make sure you see the “OK to disconnect” in the iPod display before you disconnect it. Make sure to follow the iPod’s instructions on how to disconnect the dock connector from the USB adapter cable.

*: The displayed message may vary on models or versions. On some models, there is no message to disconnect.

If you reconnect the same iPod, the system may begin playing where it left off, depending on what mode the iPod is in when it is reconnected.

iPod® Error Messages

If you see an error message in the display, see page 150 .

iPod® Error Messages (Models without navigation system)

If you see an error message on the audio display while playing an iPod, find the solution in the chart to the right. If you cannot clear the error message, take your vehicle to your dealer.

Error Message	Cause	Solution
USB ERROR	USB ROM Error	There is problem with the USB adapter unit.
BAD USB DEVICE PLEASE CHECK OWNERS MANUAL	Appears when an incompatible device is connected.	Disconnect the device. Then, turn the audio system off, and turn it on again. Do not reconnect the device that caused the error.
iPod NO SONG	No files in iPod	Appears when the iPod is empty. Store some files in the iPod.
UNSUPPORTED VER.	Use of unsupported iPod	Appears when an unsupported iPod is connected. See page 143 for specification information on iPods. If it appears when a supported iPod is connected, update the iPod software to the newer version.
CONNECT RETRY	Recognition failure of iPod	Appears when the system dose not acknowledge the iPod. Reconnect the iPod.

Playing a USB Flash Memory Device (Models without navigation system)

EX, EX-L, Si and Canadian SE models

Canadian SE model

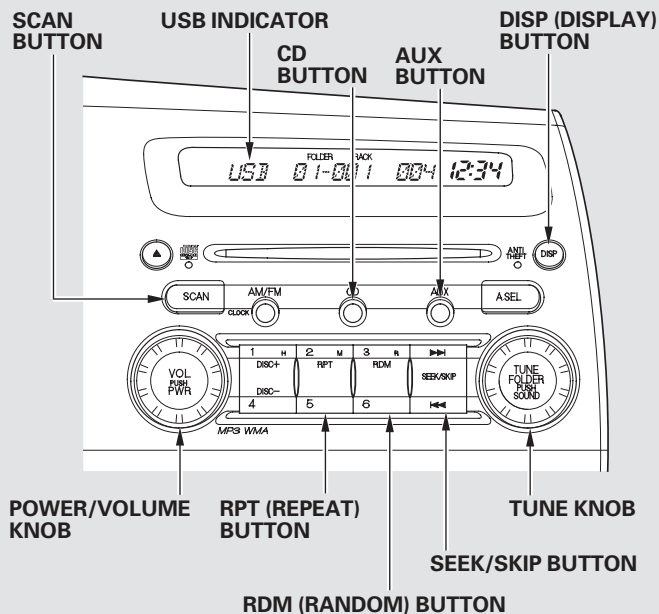

EX, EX-L, and Si models

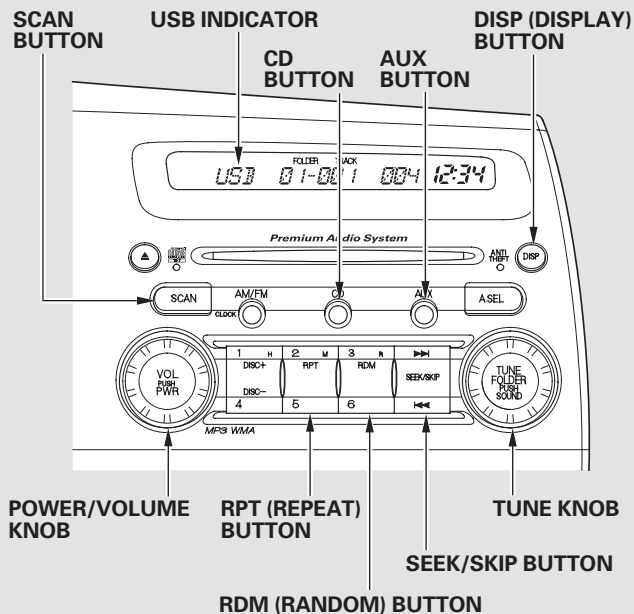

Playing a USB Flash Memory Device (Models without navigation system)

To Play a USB Flash Memory Device

This audio system can select and play the audio files on a USB flash memory device with the same controls used for the disc player. To play a USB flash memory device, connect it to the USB adapter cable in the console compartment, then press the AUX button. The ignition switch must be in the ACCESSORY (I) or ON (II) position.

The audio system reads and plays the audio files on the USB flash memory device in MP3, WMA or AAC* formats. The USB flash memory device limit is up to 700 folders or up to 65535 files.

* Only AAC format files recorded with iTunes are playable on this audio unit.

The recommended USB flash memory devices are 256 MB or higher, and formatted with the FAT file system. Some digital audio players may be compatible as well.

Some USB flash memory devices (such as devices with security lock-out features, etc.) will not work in this audio unit.

NOTE:

- Do not use a device such as a card reader or hard drive as the device or your files may be damaged.
- Do not connect your USB flash memory device using a hub.
- Do not use an extension cable to the USB adapter cable equipped with your vehicle.

- Do not keep a USB flash memory device in the vehicle. Direct sunlight and high heat will damage it.
- We recommend backing up your data before playing a USB flash memory device.
- Some devices cannot be powered or charged via the USB adapter. If this is the case, use the accessory adapter to supply power to your device.
- Depending on the type and number of files, it may take some time before they begin to play.
- Depending on the software the files were made with, it may not be possible to play some files, or display some text data.

Playing a USB Flash Memory Device (Models without navigation system)

- Depending on the type of encoding and writing software used, there may be cases where character information does not display properly.
- The order of files in USB playback may be different from the order of files displayed in PC or other devices etc. Files are played in the order stored in USB flash memory device.

Some versions of MP3, WMA, or AAC format may not be supported. If an unsupported file is found, the audio unit displays UNSUPPORTED, then skips to the next file.

In WMA or AAC format, DRM (digital rights management) files cannot be played. If the system finds a DRM file, the audio unit displays UNPLAYABLE FILE, and then skips to the next file.

NOTICE

Combining a low sampling frequency with a low bitrate may result in extremely degraded sound quality.

Connecting a USB Flash Memory Device

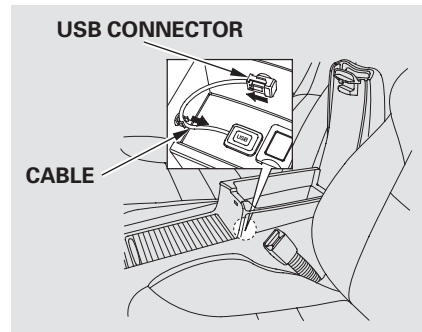

1. Pull out the USB connector from the holder and remove the cable from the clip in the console compartment.

CONTINUED

Playing a USB Flash Memory Device (Models without navigation system)

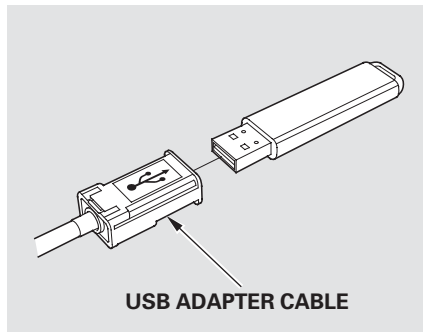

2. Connect the USB flash memory device to the USB adapter cable correctly and securely.

When the USB flash memory device is connected, the display shows a “USB CONNECTED” message for a few seconds. If the AUX mode is selected, a “USB LOAD” message is displayed for a few seconds.

When the USB flash memory device is connected, the USB indicator is shown in the display.

Text Data Display Function

Each time you press the DISP button, the display mode shows you in sequence, the folder name, the file name, the artist tag, the album tag, the track tag and name off (which turns off the text display).

The display shows up to 16 characters of the selected data. If the text data has more than 17 characters, you will see the first 15 characters and the > indicator in the display. Press and hold the DISP button until the next 16 characters are shown.

If you press and hold the DISP button again, the display shows the first 15 characters again.

Playing a USB Flash Memory Device (Models without navigation system)

To Change or Select Files

Use the SEEK/SKIP button while a USB flash memory device is playing to select passages and change files.

SKIP — Each time you press and release the ►►| side of the SEEK/SKIP button, the system skips forward to the beginning of the next file. Press and release the |◄◄ side of the button to skip backward to the beginning of the current file. Press it again to skip to the beginning of the previous file.

To move rapidly within a file, press and hold either side (►►| or |◄◄) of the SEEK/SKIP button.

FOLDER SELECTION — To select a different folder, turn the TUNE knob right or left. Turn to the right to skip to the next folder, and turn to the left to skip to the previous folder. Turning the TUNE knob more than two clicks skips several folders.

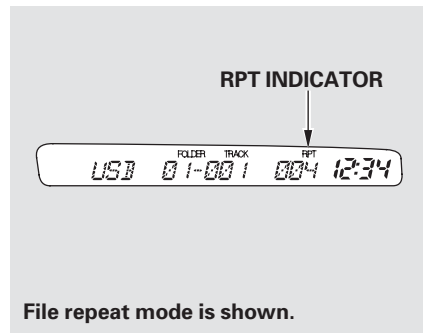

RPT (File Repeat) — This feature continuously plays a file. To activate file repeat, press and release the RPT button (preset 2). You will see RPT in the display.

F-RPT (Folder Repeat) — This feature replays all the files in the selected folder in the order they are stored. To activate folder repeat, press and release the RPT button (preset 2) repeatedly until you see F-RPT in the display.

Each time you press and release the RPT button, the mode changes from file repeat to folder repeat, then to normal play.

Press and hold the button until you hear a beep to turn off either repeat mode. Pressing either side of the SEEK/SKIP button also turns off this feature.

CONTINUED

Playing a USB Flash Memory Device (Models without navigation system)

F-RDM (Folder Random) – This feature plays the files in the selected folder in random order. To activate folder random, press and release the RDM button (preset 3). You will see F-RDM in the display.

RDM (All Random) – This feature plays all the files in random order. To activate all random, press and release the RDM button (preset 3) repeatedly until you see RDM in the display.

Each time you press and release the RDM button, the mode changes from folder random, to all random, then to normal play.

Press and hold the button until you hear a beep to turn off either random mode.

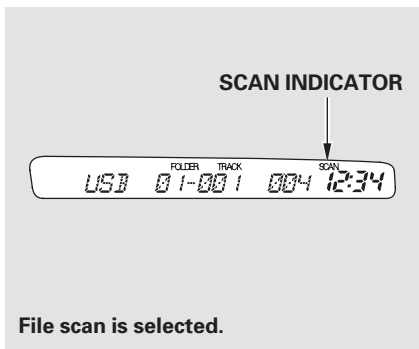

SCAN (File Scan) – This feature samples all files in the selected folder in the order they are stored. To activate the scan, press and release the SCAN button. You will see SCAN in the display. You will get a 10 second sampling of the file in each folder.

F-SCAN (Folder Scan) – This feature samples the first file in each folder in the order they are stored. To activate folder scan, press and release the SCAN button repeatedly until you see F-SCAN in the display. You will get a 10 second sampling of the first file in each folder.

Each time you press and release the SCAN button, the mode changes from file scan to folder scan, then to normal play.

Press and hold the button until you hear a beep to turn off either scan mode.

Playing a USB Flash Memory Device (Models without navigation system)

To Stop Playing a USB Flash Memory Device

To play the radio, press the AM/FM button. Press the CD button to switch to the disc mode (if a disc is loaded). Pressing the AUX button switches the audio mode between the USB and AUX.

You can also press the MODE button on the steering wheel to change modes.

Disconnecting a USB Flash Memory Device

You can disconnect the USB flash memory device at any time even if the USB mode is selected on the audio system. With the AUX mode, you will see a “USB NO DATA” message in the display. Make sure to follow the USB flash memory device’s instructions when you remove it.

If you reconnect the same USB flash memory device, the system will begin playing where it left off.

USB Flash Memory Device Error Messages

If you see an error message in the display, see page 158 .

USB Flash Memory Device Error Messages (Models without navigation system)

If you see an error message on the audio display while playing a USB flash memory device, find the solution in the chart to the right. If you cannot clear the error message, take your vehicle to your dealer.

Error Message	Cause	Solution
USB ERROR	USB ROM Error	There is problem with the USB adapter unit.
BAD USB DEVICE PLEASE CHECK OWNERS MANUAL	Appears when an incompatible device is connected.	Disconnect the device. Then, turn the audio system off, and turn it on again. Do not reconnect the device that caused the error.
UNPLAYABLE FILE	Use of unsupported files	Appears when the files in the USB flash memory device are DRM or an unsupported format. This error message appears for about 3 seconds, then plays the next song.
USB NO SONG	No files in USB flash memory device	Appears when the USB flash memory device is empty or there are no MP3, WMA, or AAC files in the USB flash memory device. Save some MP3, WMA, or AAC files in the USB flash memory device.
UNSUPPORTED	Use of unsupported USB flash memory device	Appears when an unsupported device is connected. See page 152 for the specification information for the USB flash memory device. If it appears when the supported device is connected, reconnect the device.

Audio System (Models with navigation system)

Voice Control System

The audio system can also be operated by voice control. See the navigation system manual for complete details.

U.S. model

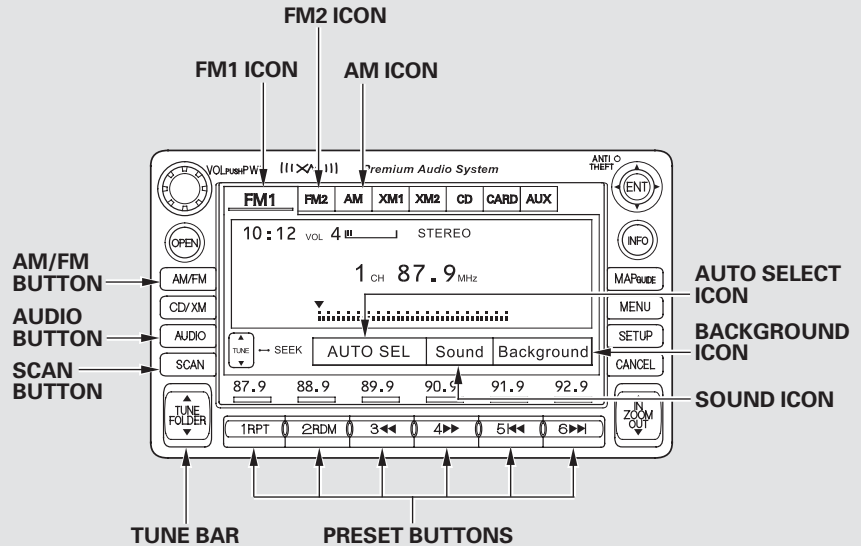

Playing the AM/FM Radio (Models with navigation system)

To Play the AM/FM Radio

The ignition switch must be in the ACCESSORY (I) or ON (II) position. Turn the system on by pushing the power/volume knob or the AM/FM button. Adjust the volume by turning the power/volume knob.

Pushing the AUDIO button will also turn on the system.

You can also operate the audio system without using the control icons on the audio screen. Use the control buttons on the left side of the screen. The status bar appears on the bottom of the screen each time you operate any of the control buttons. On the navigation screen, you can also see audio information by touching the AUDIO INFO icon on the lower half of the screen.

The band and frequency that the radio was last tuned to are displayed. To change bands, press the AM/FM button, or touch the desired band icon (FM1, FM2, AM, XM1, or XM2). On the FM band, STEREO will be displayed if the station is broadcasting in stereo. Stereo reproduction on AM is not available.

For information on XM Radio, see page 163.

To Select a Station

You can use any of five methods to find radio stations on the selected band: tune, seek, scan, the preset buttons, and auto select.

TUNE — Use the TUNE bar to tune the radio to a desired frequency. Press the ▲ side of the bar to tune to a higher frequency, and press the ▼ side to tune to a lower frequency.

Press and hold the ▲ or ▼ side of the TUNE bar until you hear two beeps to change the frequency rapidly. Release the bar when the display reaches the desired frequency.

Playing the AM/FM Radio (Models with navigation system)

SEEK — The seek function searches up and down from the current frequency to find a station with a strong signal. To activate it, press and hold the ▲ or ▼ side of the TUNE bar until you hear a beep, then release it.

SCAN — The scan function samples all stations with strong signals on the selected band. To activate it, press the SCAN button, then release it. You will see SCAN in the display. When the system finds a strong signal, it will stop and play that station for about 10 seconds.

If you do nothing, the system will then scan for the next strong station and play it for 10 seconds. When it plays a station you want to listen to, press the SCAN button again.

Preset — Each preset button can store one frequency on AM and two frequencies on FM.

1. Select the desired band, AM or FM. FM1 and FM2 let you store six stations each.
2. Use the tune, seek, or scan function to tune the radio to a desired station.
3. Pick a preset button, and hold it until you hear a beep.
4. Repeat steps 1 through 3 to store a total of six stations on AM and twelve stations on FM.

Each preset button's frequency is shown on the bottom of the audio display.

CONTINUED

Playing the AM/FM Radio (Models with navigation system)

AUTO SELECT – If you are traveling and can no longer receive your preset stations, you can use the auto select feature to find stations in the local area.

Press the AUDIO button to view the audio control icons, then touch the AUTO SEL icon. You will see AUTO SEL flashing in the display, and the system goes into scan mode for several seconds. It stores the frequencies of six AM, and twelve FM stations in the preset buttons.

You will see a “0” displayed after pressing a preset button if auto select cannot find a strong station for every preset button.

If you do not like the stations auto select has stored, you can store other frequencies on the preset buttons as previously described.

To turn off auto select, press the AUTO SEL icon. This restores the presets you originally set.

For information on AM/FM radio frequencies and reception, see page 214 .

Playing the XM® Radio (Models with navigation system)

U.S. model

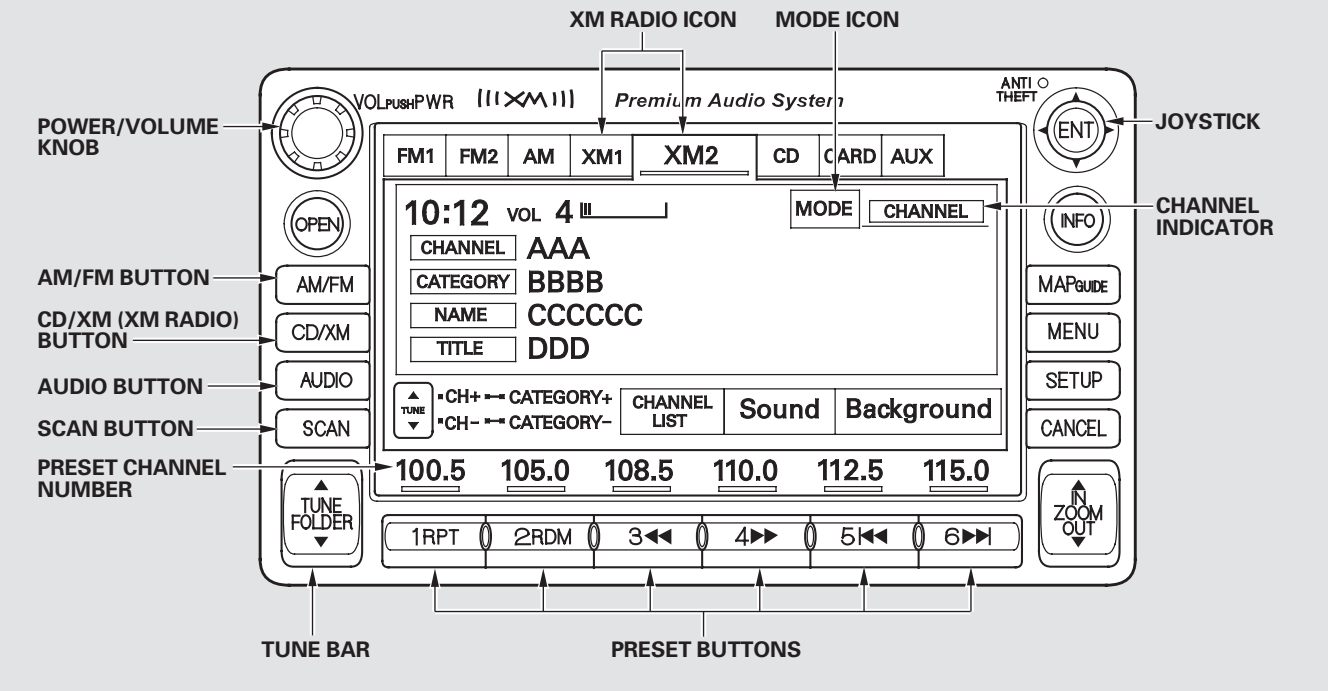

Features

Playing the XM® Radio (Models with navigation system)

Your audio system is capable of receiving XM® Radio anywhere in the United States, except Hawaii, Alaska, and Puerto Rico.

XM is a registered trademark of Sirius XM Radio®, Inc.

XM Radio receives signals from two satellites to produce clear, high-quality digital reception. It offers many channels in several categories. Along with a large selection of different types of music, XM Radio allows you to view channel and category selections in the display. When you press and hold the AUDIO button, the display also shows all XM information.

Operating the XM Radio

To listen to XM Radio, turn the ignition switch to the ACCESSORY (I) or the ON (II) position. Press the CD/XM button to select XM Radio. Adjust the volume by turning the power/volume knob. The last channel you listened to will show in the display.

You can also change to the XM Radio while you are listening to an FM station, AM station, disc, PC card, etc., by touching the XM1 or XM2 icon on the audio display.

You can also operate the radio using the control buttons on the left side of the screen. The status bar appears on the bottom of the screen each time you press any of the control buttons. On the navigation screen, you can also see the audio information by touching the AUDIO INFO icon on the lower part of the screen.

MODE — To switch between channel mode and category mode, touch the MODE icon. In channel mode, you can select all of the available channels. In category mode, such as Jazz, Rock, Classical, etc., you can select all of the channels within that category. Each time you touch and release the MODE icon, the display changes between the channel mode and the category mode.

Playing the XM® Radio (Models with navigation system)

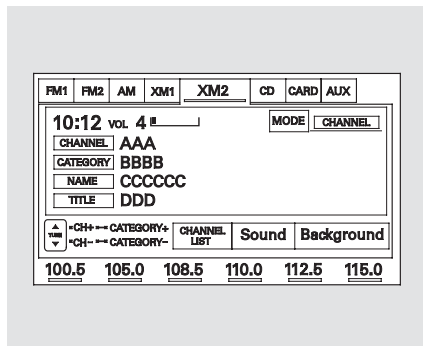

On the audio display, you will see the selected CHANNEL (number), CATEGORY, NAME (artist name), and TITLE (music title).

You may experience periods when XM Radio does not transmit the artist's name and song title information. If this happens, there is nothing wrong with your system.

TUNE — Press the TUNE bar to change channel selections. Press ▲ for higher numbered channels and ▼ for lower numbered channels. In the category mode, you can only select channels within that category.

CATEGORY — Press and hold either side of the TUNE bar (◀◀ or ▶▶) until you hear a beep to select another category.

SCAN — The scan function gives you a sampling of all channels while in the channel mode. In the category mode, only the channels within that category are scanned. To activate scan, press the SCAN button or touch the SCAN icon on the screen. The system plays each channel in numerical order for a few seconds, then selects the next channel. When you hear a channel you want to listen to, press the button or touch the icon again.

Preset — You can store up to 12 preset channels using each preset button or preset icons on the screen. Each preset button or icon stores one channel from the XM1 band and one channel from the XM2 band.

To store a channel:

1. Press the XM button. Either XM1 or XM2 will show in the display.
2. Use the tune, seek, or scan function to tune to a desired channel.
3. Pick the preset button (icon) you want for that channel. Press and hold the button (icon) until you hear a beep.

CONTINUED

Playing the XM® Radio (Models with navigation system)

- Repeat steps 2 and 3 to store the first six channels.
- Press the XM button again or touch the other XM icon (XM1 or XM2) on the audio display. Store the next six channels using steps 2 and 3.

Once a channel is stored, press and release the proper preset button (icon) to tune to it. Each preset button's channel is shown on the bottom of the audio display.

To Select a Channel from List

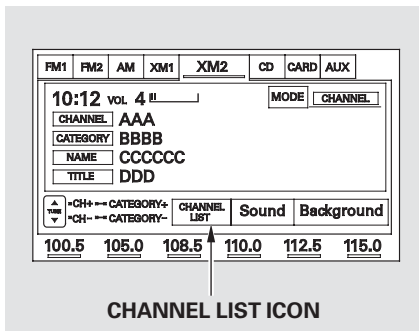

You can also select a desired channel from the list shown on the screen. Press the AUDIO button to show the audio control display on the navigation screen.

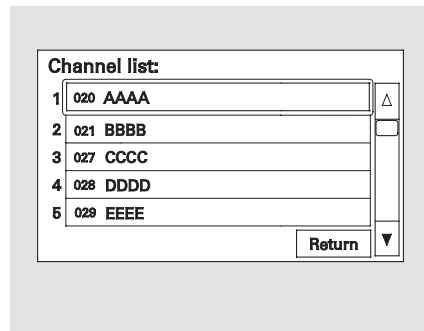

Touch the CHANNEL LIST icon to switch the display to the channel list which shows all channels in all categories. Select and touch a desired channel.

To scroll through the display, touch the ▲ or ▼ icon on the side of the screen. To go back to the previous display, touch the Return icon on the screen.

Playing the XM[®] Radio (Models with navigation system)

To select a desired icon with the joystick, move it in the appropriate direction, then press ENT.

XM Radio Display Messages

“LOADING” – XM is loading the audio or program information.

“OFF AIR” – The channel currently selected is no longer broadcasting.

“UPDATING” – The encryption code is being updated. Wait until the encryption code is fully updated. Channels 0 and 1 should still work normally.

“NO SIGNAL” – The signal is currently too weak. Move the vehicle to an area away from tall buildings, and with an unobstructed view of the southern horizon.

“ - - - - ” – The selected channel number does not exist or is not part of your subscription.

“NO INFO” – The selected channel has no artist or title information at this time.

“ANTENNA” – There is a problem with the XM antenna. Please consult your dealer.

CONTINUED

Playing the XM® Radio (Models with navigation system)

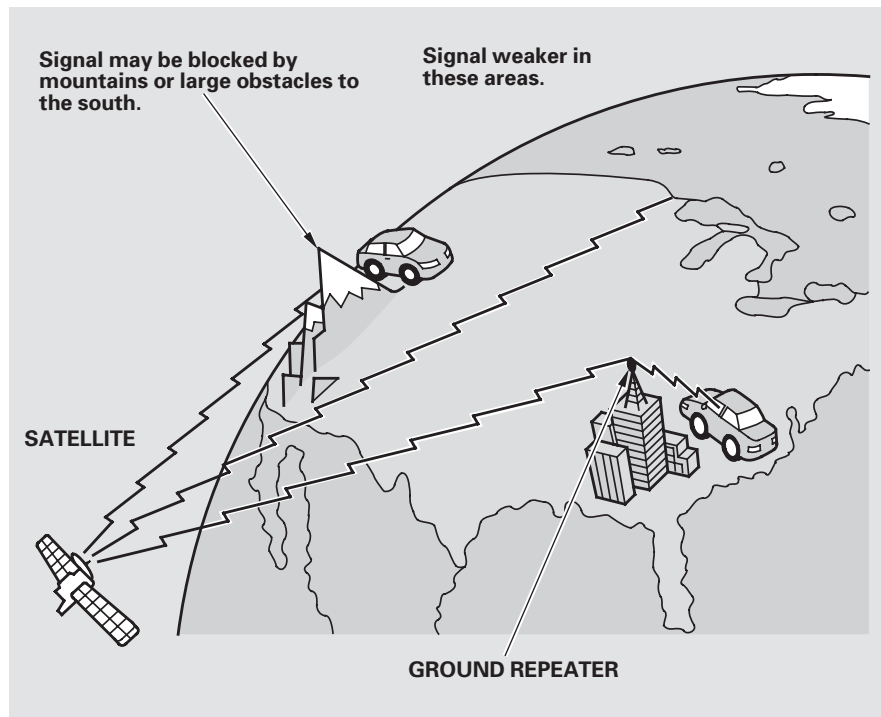

The XM satellites are in orbit over the equator; therefore, objects south of the vehicle may cause satellite reception interruptions. To help compensate for this, ground-based repeaters are placed in major metropolitan areas.

Satellite signals are more likely to be blocked by tall buildings and mountains the farther north you travel from the equator. Carrying large items on a roof rack can also block the signal.

Depending on where you drive, you may experience reception problems. Interference can be caused by any of these conditions:

- Driving on the north side of an east/west mountain road.
- Driving on the north side of a large commercial truck on an east/west road.

Playing the XM[®] Radio (Models with navigation system)

- Driving in tunnels.
- Driving on a road beside a vertical wall, steep cliff, or hill to the south of you.
- Driving on the lower level of a multi-tiered road.
- Driving on a single lane road alongside dense trees taller than 50 ft. (15 m) to the south of you.
- Large items carried on a roof rack.

There may be other geographic situations that could affect XM Radio reception.

*As required by the FCC:
Changes or modifications not expressly approved by the party responsible for compliance could void the user's authority to operate the equipment.*

Receiving XM Radio Service

If your XM Radio service has expired or you purchased your vehicle from a previous owner, you can listen to a sampling of the broadcasts available on XM Radio. With the ignition switch in the ACCESSORY (I) or ON (II) position, push the power/volume knob to turn on the audio system and press the CD/XM button. A variety of music types and styles will play.

If you decide to purchase XM Radio service, contact XM[®] Radio at www.xmradio.com, or at 1-800-852-9696. You will need to give them your radio I.D. number and your credit card number. To get your radio I.D. number, press the TUNE bar until "0" appears in the display. Your I.D. will appear in the display.

After you've registered with XM Radio, keep your audio system in the XM radio mode while you wait for activation. This should take about 30 minutes.

While waiting for activation, make sure your vehicle remains in an open area with good reception. Once your audio system is activated, you'll be able to listen to XM Radio broadcasts. XM Radio will continue to send an activation signal to your vehicle for at least 12 hours from the activation request. If the service has not been activated after 36 hours, contact XM[®] Radio. In Canada, contact XM CANADA[®].

Adjusting the Sound (Models with navigation system)

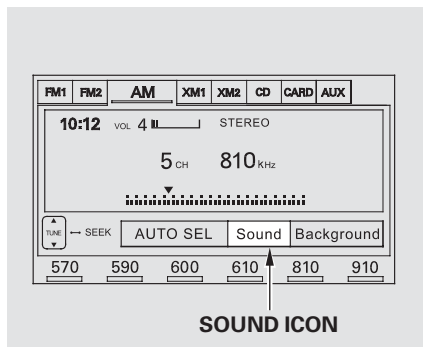

You can adjust the sound on the navigation screen. To adjust the sound, push the AUDIO button, then enter the sound grid by touching the SOUND icon on the display.

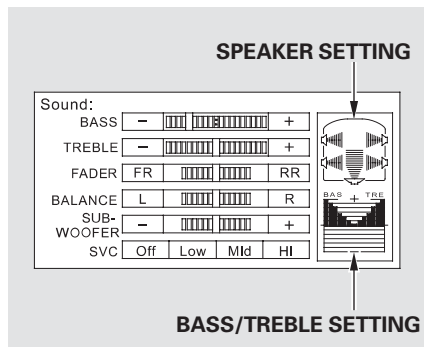

BASS – Adjusts the bass.

TREBLE – Adjusts the treble. To adjust the treble and bass, touch either **+** or **-** on the treble or bass adjustment bar. The adjustment bar on the lower right display shows you the current setting.

FADER – Adjusts the front-to-back strength of the sound. To adjust the front/rear fader, touch the FR or RR icon.

BALANCE – Adjusts the side-to-side strength of the sound. To adjust the left/right balance, touch the L or R icon.

SUBWOOFER – Adjusts the strength of sound from the subwoofer speaker. To adjust the sound strength, touch **+** or **-** on each side of the adjustment bar.

The right upper display shows you the current setting of the sound strength coming from each speaker.

SVC (speed-sensitive volume compensation) – The SVC mode controls the volume based on vehicle speed. The faster you go, the louder the audio volume becomes. As you slow down, the audio volume decreases. Touch the appropriate icon (Low, Mid, Hi, Off) to select the mode.

If you feel the sound is too loud, choose low. If you feel the sound is too quiet, choose Hi.

You can also select the icon with the joystick. Move it up and down to move the highlighting and scroll through lists. Select the icon, then move the joystick to left or right to change the setting.

The system will return to the audio display about 10 seconds after you stop adjusting a mode.

Screen Mode

You can select the background screen to display the sound level. There are three screen modes: level (the sound level is shown with the vertical bars), spectrum analysis (the sound level appears as ripples of water), and off. Each time you touch the background icon, the display changes.

Audio System Lighting

You can use the instrument panel brightness control buttons to adjust the illumination of the audio system (see page 76). The audio system illuminates when the parking lights are on, even if the radio is off.

Playing a Disc (Models with navigation system)

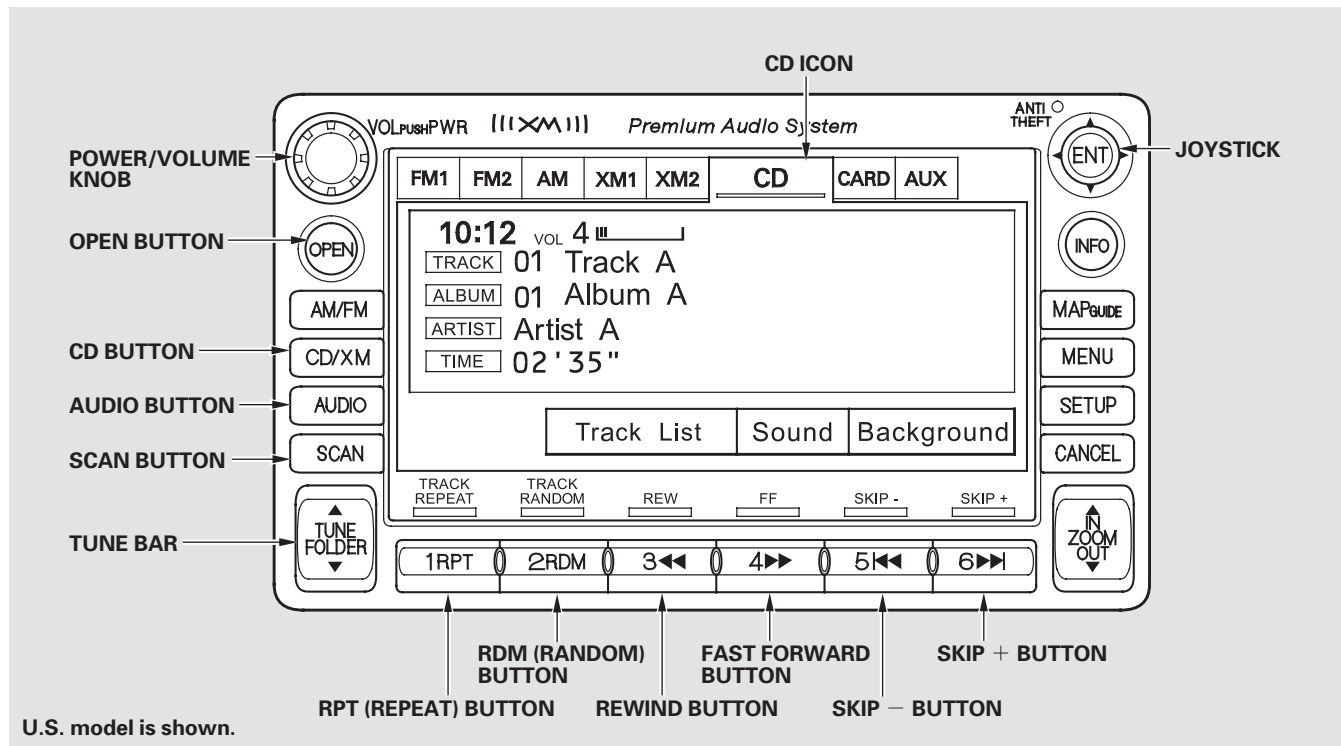

Playing a Disc (Models with navigation system)

To Play a Disc

You operate the disc player with the same controls used for the radio. To load or play discs, the ignition switch must be in the ACCESSORY (I) or ON (II) position.

NOTICE

Do not use discs with adhesive labels. The label can curl up and cause the disc to jam in the unit.

This audio system can also play CD-Rs and CD-RWs compressed in MP3 or WMA formats. When playing a disc in MP3, you will see “MP3” on the screen. In WMA format, “WMA” will appear on the screen. You can select up to 99 folders and play up to 999 tracks. If the disc has a complex structure, it takes a while to read the disc before the system begins to play it.

Video CDs and DVDs do not work in this unit.

NOTE:

If a file on WMA disc is protected by digital rights management (DRM), the audio unit displays CD FORMAT, and then skips to the next file.

Depending on the software the files were made with, it may not be possible to play some files, or display some text data.

To Load a Disc

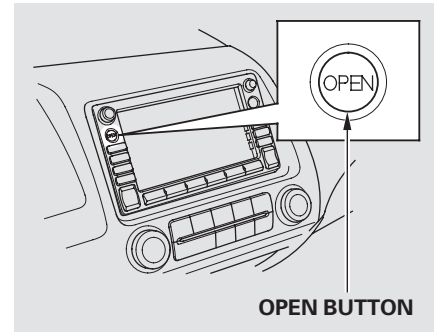

The disc player is behind the navigation screen. To use the disc player, press the OPEN button beside the screen. The screen folds back, and the disc player appears.

CONTINUED

Playing a Disc (Models with navigation system)

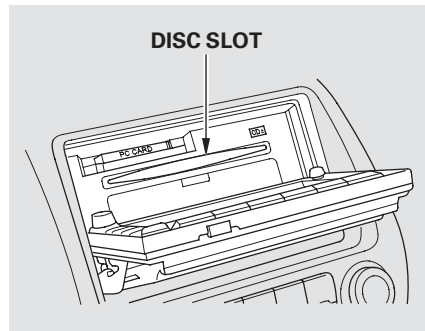

Insert a disc about halfway into the disc slot. The drive will pull the disc in the rest of the way and begin to play it.

You cannot load and play 3-inch (8-cm) discs in this system.

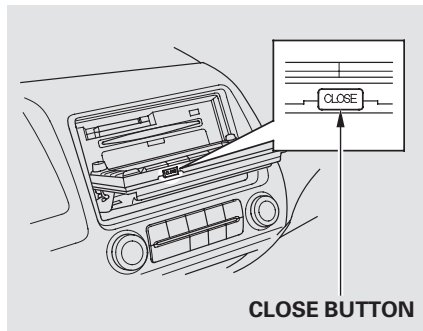

To return the screen to the upright position, press the CLOSE button on the edge of the screen panel. Do not use the folded down screen as a tray. If you put a cup, for example, on the screen, the liquid inside the cup may spill on the screen when you go over a bump.

Push the AUDIO button beside the screen to show the audio display and operate the disc player.

You can also operate the audio system without using the control icons on the audio screen. Press the CD button. The status bar appears on the bottom of the screen. On the navigation screen, you can see the audio information whenever you touch the AUDIO INFO icon on the lower portion of the screen.

When playing a CD recorded with text data, the track, album, and artist name are shown on the audio display. When playing a disc in MP3 or WMA, the folder number and name, the file number and name, the artist name, and the elapsed time are shown. The system will continuously play a disc until you change modes. If the disc was not recorded with text data, it will not be displayed.

Playing a Disc (Models with navigation system)

To Change or Select Tracks/Files

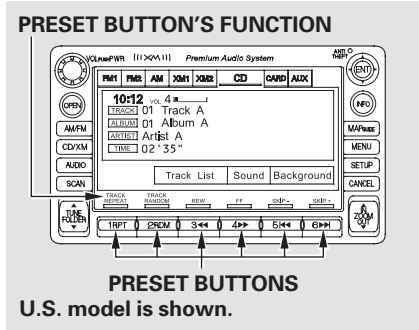

You can use the preset buttons while a disc is playing to select passages and change tracks (files in MP3 or WMA mode). Each preset button's function is shown on the bottom of the screen.

You can also select an icon with the joystick. Move it to left, right, up, or down to change the highlighting and scroll through lists. Then press ENT on the top of the joystick to select the icon.

SKIP — Each time you press and release ►► (preset 6 button), the player skips forward to the beginning of the next track (file in MP3 or WMA mode). Press and release ◀◀ (preset 5 button), to skip backward to the beginning of the current track. Press it again to skip to the beginning of the previous track.

FF/REW — To move rapidly within a track/file, press and hold ►► (preset 4 button) or ◀◀ (preset 3 button).

In MP3 or WMA mode

FOLDER SELECTION — To select a different folder, press either side of the TUNE bar to move to the beginning of the next folder. Press the ▲ side of the TUNE bar to skip to the next folder, and the ▼ side to move to the beginning of the previous folder.

TRACK REPEAT (FILE REPEAT) — To continuously replay a track (file in MP3 or WMA mode), press and release the RPT button (preset 1). You will see TRACK REPEAT in the display. Press and hold the RPT button for 2 seconds to turn it off.

CONTINUED

Playing a Disc (Models with navigation system)

In MP3 or WMA mode

FOLDER REPEAT — This feature, when activated, replays all files in the selected folder in the order they are compressed. To activate folder repeat, press and hold the RPT button (preset 1). You will see FOLDER REPEAT in the display. The system continuously replays the current folder. Press the RPT button again to turn it off. Pressing the RDM button or selecting a different folder with the TUNE bar also turns off folder repeat.

TRACK RANDOM (Random within a disc/folder) — This feature plays the tracks within a disc (the files within a folder) in random order. To activate track random, press and release the RDM button (preset 2). You will see TRACK RANDOM in the display. Press and hold the RDM button for 2 seconds to return to normal play.

In MP3 or WMA mode

FOLDER RANDOM — This feature, when activated, plays all files in each folder in random order, rather than in the order they are compressed. To activate folder random, press the RDM button (preset 2) twice. You will see FOLDER RANDOM in the display. The system then selects and plays files randomly. This continues until you deactivate folder random by pressing the RDM button again, or if you select a different folder with the TUNE bar.

SCAN (TRACK/FILE SCAN) —

The scan function samples all tracks (files in MP3 or WMA) in the order they were recorded. To activate scan, press and release the SCAN button. You will see TRACK SCAN in the display. You will get a 10 second sampling of each track/file on the disc. Press and hold the SCAN button for 2 seconds to get out of scan mode and play the last track/file sampled.

Pressing either SKIP button (preset 5 button or 6 button) also turns off scan.

Playing a Disc (Models with navigation system)

In MP3 or WMA mode

FOLDER SCAN – This feature, when activated, samples all the first files in each folder on the disc in order. To activate folder scan, press and hold the SCAN button. You will see FOLDER SCAN in the display.

The system plays the first file in each folder for about 10 seconds. If you do nothing, the system then plays the first file in each folder for 10 seconds each. After playing the first file of the last folder, the system goes to normal play.

Pressing either SKIP button (preset 5 or 6), or selecting a different folder with the TUNE bar, or pressing the SCAN button, also turns off folder scan.

Using a Track List

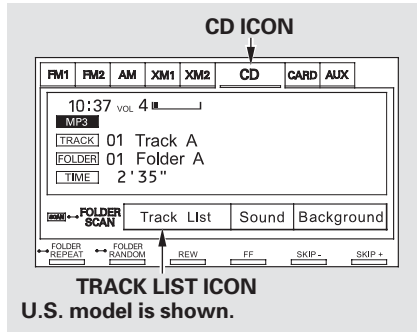

You can also select a track/file directly from the folder and file lists on the audio display. Press the AUDIO button to show the audio display.

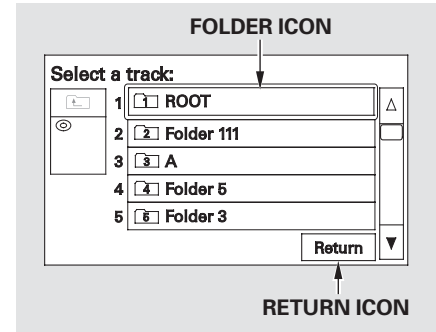

Touch the Track List icon to switch the display to the folder list, then select and touch a desired folder.

CONTINUED

Playing a Disc (Models with navigation system)

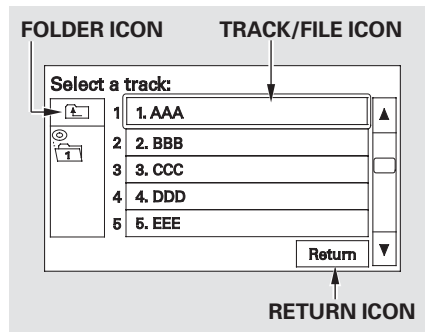

The display changes to the file list. Then, select and touch a desired file.

Touch the folder icon on the upper left of the screen to move to the parent folder.

To scroll through the display, touch the ▲ or ▼ icon on the side of the screen. To go back to the previous display, touch the Return icon on the screen.

To select a desired icon with the joystick, move it in the appropriate direction, then press ENT.

Press the AUDIO button to go back to the normal audio playing display. Pressing the CANCEL button goes back to the previous screen, and pressing the MAP button cancels the audio control display on the screen.

When playing a CD recorded with text data, each track name is shown on the audio display. With a disc recorded in MP3 or WMA, the folder number is also displayed.

If the disc was not recorded with text data, only the track number is shown.

To Stop Playing a Disc

To play the radio when a disc is playing, press the AM/FM button or touch the FM1, FM2, AM, XM1, or XM2 icon. If a PC card is in the audio unit, touch the CARD icon to play the PC card. Press the CD button again or touch the CD icon to switch back to the disc player.

To play an audio unit connected to the auxiliary input jack or the USB adapter cable when a disc is playing, touch the AUX or USB icon.

You can also press the MODE button on the steering wheel to change modes.

If you turn the system off while a disc is playing, either with the power/volume knob or by turning off the ignition switch, the disc will stay in the drive. When you turn the system back on, the disc will begin playing where it left off.

Removing a Disc

To remove a disc from the audio unit, fold back the screen by pressing the OPEN button (see page 173). Press the disc eject button (▲) to remove the disc. If you eject the disc, but do not remove it from the slot, the system will automatically reload it after 10 seconds and put it in pause mode. To begin playing, press the CD button.

To return the screen to the upright position, press the CLOSE button.

You cannot close the screen if a disc is partially inserted into its slot.

You can also eject the disc when the ignition switch is off.

Operating the Optional Disc Changer

An optional six or eight disc changer is available for your vehicle. This disc changer uses the same controls used for the in-dash disc player or the radio.

Load the desired discs in the magazine, and load the magazine in the changer according to the instructions that came with the unit.

To select the disc changer, press the CD/XM button. The disc and track numbers will be displayed. To select a different disc, use either side of the TUNE bar. To select the previous disc, press the ▲ side. To select the next disc, press the ▼ side.

If you select an empty slot in the magazine, the changer will search for the next available disc to load and play.

Protecting Discs

For information on how to handle and protect discs, see page 216 .

Disc Player Error Messages (Models with navigation system)

The chart on the right explains the error messages you may see in the display while playing a disc.

If you see an error message in the display while playing a disc, press the eject button. After ejecting the disc, check it for damage or deformation. If there is no damage, insert the disc again.

For additional information on damaged discs, see page 217 .

If there is still a problem, the error message will appear again. Press the eject button, and pull out the disc.

Insert a different disc. If the new disc plays, there is a problem with the first disc. If the error message cycle repeats and you cannot clear it, take your vehicle to a dealer.

Error Message	Cause	Solution
CD DISC ERROR	FOCUS Error	Press the eject button, and pull out the disc. Check if it is inserted correctly in the disc player. Make sure the disc is not scratched or damaged (see page 217).
CD MECH ERROR	Mechanical Error	Press the eject button, and pull out the disc. Check the disc for damage or deformation (see page 217). If the disc cannot be pulled out, or the error message does not disappear after the disc is ejected, see your dealer.
CD DISC	TOC Error	Press the eject button, and pull out the disc. Check the disc for damage or deformation (see page 217).
CD HEAT ERROR	High Temperature	Will disappear when the temperature returns to normal.

Playing a PC Card (Models with navigation system)

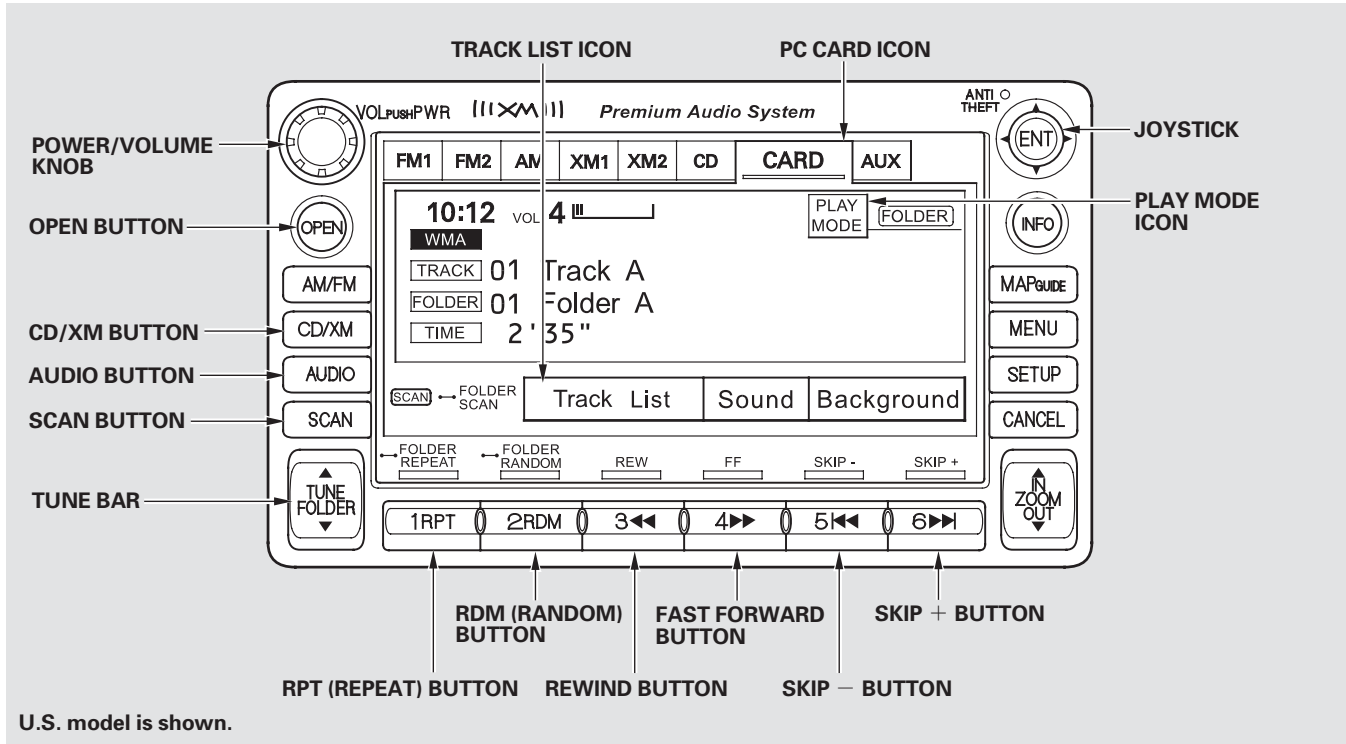

Playing a PC Card (Models with navigation system)

To Play a PC Card

You operate the PC card player with the same controls used for the radio and the disc player. To load or play a card, the ignition switch must be in the ACCESSORY (I) or ON (II) position.

The PC card player reads and plays cards in MP3 or WMA formats. Depending on the format, the screen will indicate “MP3” or “WMA” when a card is playing. The card limit of the player is 99 folders and 999 tracks. If the card has a complex structure, it takes some time for the system to begin playing it.

Based on PCMCIA 2.1/JEIDA 4.2, the recommended PC cards for the PC card reader are:

CompactFlash
Flash ATA
SD memory card

Always use the recommended memory card with the appropriate adapter (if an adapter is needed). Some memory cards will not work in this unit.

NOTE:

- When you insert a PC card into the slot, make sure you put it in straight. If you cannot insert it, remove it, and insert again.
- Do not keep PC cards in the vehicle. Direct sunlight and high heat will damage them.
- To avoid damaging the card reader, do not insert hard disc drive cards into the PC card slot.
- You cannot close the screen (move it to the upright position) until the PC card is inserted all the way into its slot or removed.

- Never insert foreign objects into the PC card slot.

Depending on the software the files were made with, it may not be possible to play some files, or display some text data.

In WMA format, DRM (digital rights management) files cannot be played. If the system finds a DRM file, it skips that file and plays the next available folder or file.

Playing a PC Card (Models with navigation system)

Loading a PC Card

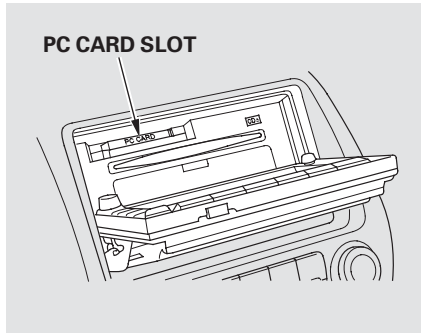

The PC card slot is behind the navigation screen. To use the PC card player, press the OPEN button beside the screen. The screen folds back, and the PC card slot appears.

Insert a PC card straight into the slot. The drive will read the PC card and begin to play it.

Return the screen to the upright position by pressing the CLOSE button on the edge of the screen panel.

Push the AUDIO button beside the screen to show the audio display and operate the PC card player.

You can also operate the audio system without using the control icons on the audio screen. Press any of the appropriate control buttons. The status bar appears on the bottom of the screen. On the navigation screen, you can see the audio information whenever you touch the AUDIO INFO icon on the screen.

CONTINUED

Playing a PC Card (Models with navigation system)

There are three play modes: Folder, Artist, and Album. Touch the PLAY MODE icon, then choose one of the modes by touching its icon. When a mode is selected, it is highlighted in blue.

- Folder mode plays tracks in the order they were added to the card.
- Artist mode plays tracks in alphabetical order, by artist and song title.
- Album mode plays albums (folders) in alphabetical order.

If play mode information was not included in the tracks when they were added to the card, it will not be displayed on the screen.

To Select a Play Mode

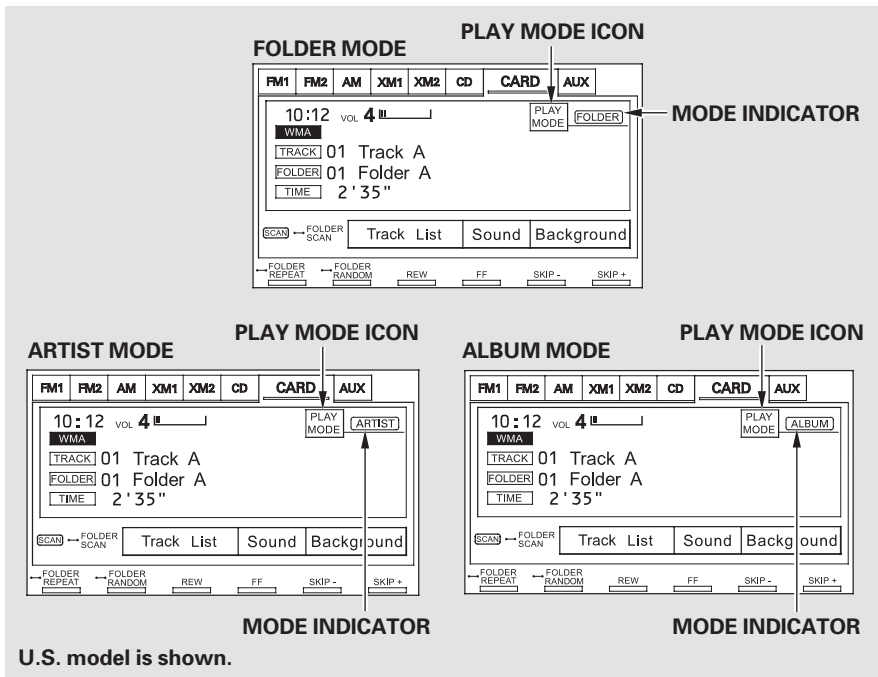

Playing a PC Card (Models with navigation system)

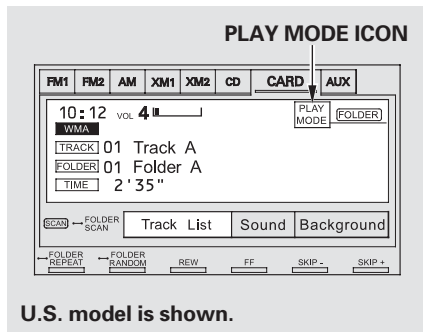

To select a play mode, push the AUDIO button to show the audio display, then touch the PLAY MODE icon on the display.

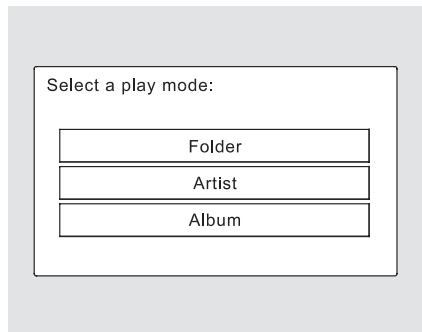

Select the desired mode by touching the appropriate icon, or move the joystick, then press ENT.

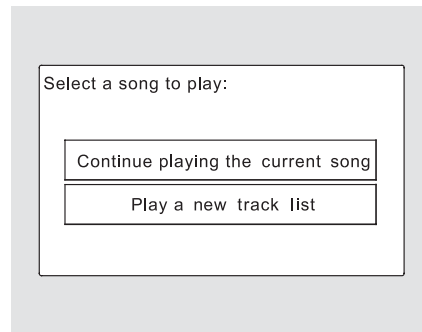

After you select the play mode, the display changes to the selectable playing menu. If you select "Continue playing the current song," the system goes into the selected play mode after playing the current file.

CONTINUED

Playing a PC Card (Models with navigation system)

If you select “Play a New Track List,” the system goes into the selected play mode immediately and begins to play the files in order to the new list.

To go back to the previous screen, press the CANCEL button on the right side of the screen. To exit the play mode screens, press the AUDIO button.

To Change or Select Tracks/Files

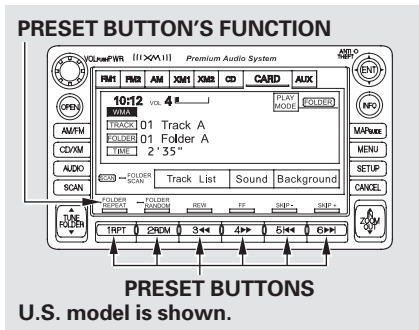

You can use the preset buttons while a card is playing to select or change files. Each preset button's function is shown on the bottom of the screen.

Icons on the screen can also be selected with the joystick. Move the joystick left or right and up or down until the icon is highlighted, then press ENT on the top of the joystick to select the icon.

SKIP — Each time you press and release ►► (preset 6 button), the player skips forward to the beginning of the next file. Press and release ◀◀ (preset 5 button), to skip backward to the beginning of the current file. Press it again to skip to the beginning of the previous file.

FF/REW — To move rapidly within a file, press and hold ►► (preset 4 button) or ◀◀ (preset 3 button).

FOLDER SELECTION — To select a different folder, press either side of the TUNE bar to move to the beginning of the next folder. Press the ▲ side of the TUNE bar to skip to the next folder, and the ▼ side to move to the beginning of the previous folder.

TRACK REPEAT (FILE REPEAT) — To continuously replay a file, press and release the RPT button (preset 1). You will see TRACK REPEAT in the display. Press the RPT button again to turn it off.

FOLDER/ARTIST/ALBUM REPEAT — This feature, when activated, replays all the files in the selected folder/artist/album in the order they are recorded or listed. To activate each repeat mode, press and hold the RPT button (preset 1) for 2 seconds. You will see FOLDER REPEAT, ARTIST REPEAT or ALBUM REPEAT in the display. The system continuously replays the current folder/artist/album. Press and hold the RPT button for 2 seconds again to turn it off. Pressing the RDM button, or selecting a different folder/artist/album with the TUNE bar also turns off the repeat feature.

TRACK RANDOM (Random within a folder) — This feature plays the files within a folder in random order. To activate track random, press and release the RDM button (preset 2). You will see TRACK RANDOM in the display. Press and hold the RDM button for 2 seconds to return to normal play.

FOLDER/ARTIST/ALBUM RANDOM — This feature, when activated, plays all files in each folder/artist/album in random order, rather than in the order they are recorded or listed. To activate each random play, press the RDM button (preset 2) 2 times. You will see FOLDER RANDOM, ARTIST RANDOM or ALBUM RANDOM in the display.

CONTINUED

Playing a PC Card (Models with navigation system)

The system then selects and plays files randomly. This continues until you deactivate each random play by pressing the RDM button again, or you select a different folder/artist/album with the TUNE bar.

SCAN — The scan function samples all files on the PC card in the order they are recorded. To activate scan, press and release the SCAN button. You will see TRACK SCAN in the display. You will get a 10 second sampling of each file on the PC card. Press and hold the SCAN button for 2 seconds to get out of scan mode and play the last file sampled.

Pressing either of the SKIP buttons (preset 5 button or 6 button) also turns off the scan feature.

FOLDER/ARTIST/ALBUM SCAN — This feature, when activated, samples the first file in each folder/artist/album on the PC card in order. To activate each scan feature, press and hold the SCAN button until you hear a beep. You will see FOLDER SCAN, ARTIST SCAN or ALBUM SCAN in the display.

The system plays the first file in the folder for about 10 seconds. If you do nothing, the system plays the first file in each folder, in order, for 10 seconds each. After playing the first file of the last folder/artist/album, the system returns to normal play.

Pressing either of the SKIP buttons (preset 5 button or 6 button), selecting a different folder/artist/album with the TUNE bar, or pressing the SCAN button, also turns off the scan feature.

Using a Track List

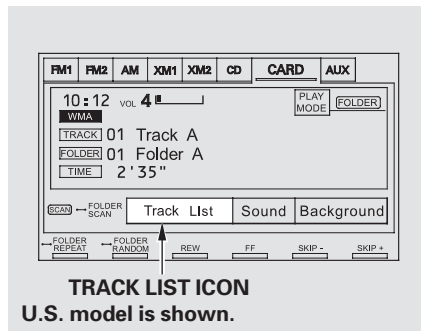

You can also select a file directly from the folder and track lists on the audio display. Press the AUDIO button to show the audio display, then touch the Track List icon. The folder list menu appears on the display.

Playing a PC Card (Models with navigation system)

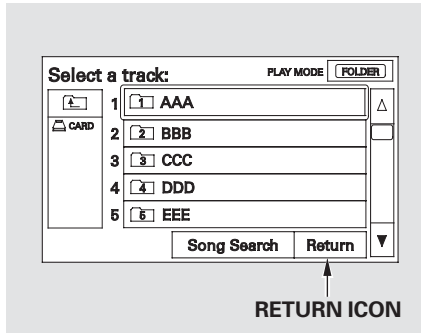

To scroll through the display, touch the ▲ or ▼ icon on the side of the screen. To go back to the previous display, touch the Return icon.

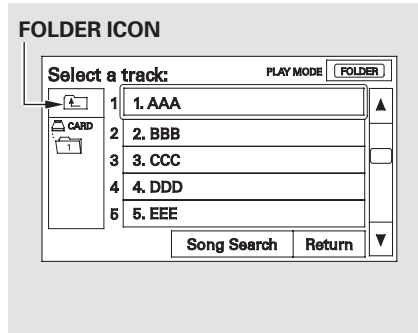

To select a folder, touch its icon on the screen. The display changes to the file list. Then, select and touch a desired file. In folder mode, touch the folder icon on the upper left of the screen to move to the parent folder.

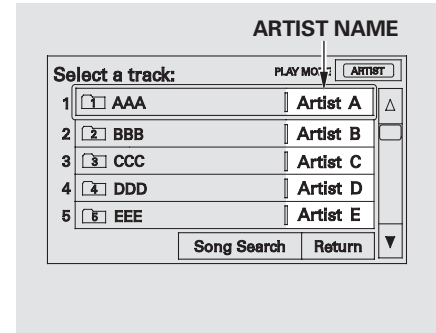

In artist mode, the artist name is also displayed on the right side of each selectable icon. Select the desired file.

CONTINUED

Playing a PC Card (Models with navigation system)

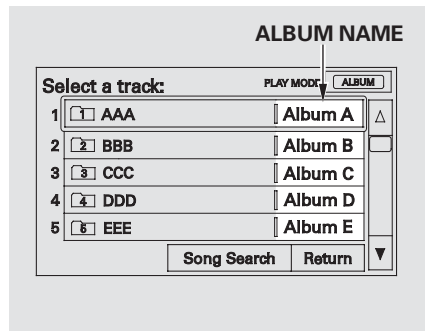

In album mode, the album name is also displayed on the right side of each selectable icon. Select the desired file.

To select a desired icon with the joystick, move it in the appropriate direction, then press ENT.

Press the AUDIO button to go back to the normal audio playing display. Pressing the CANCEL button goes back to the previous screen, and pressing the MAP button cancels the audio control display on the screen.

Song Search Function

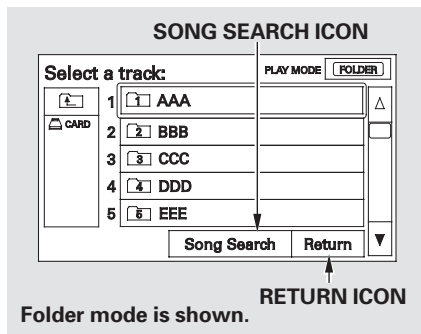

When you select "Song Search" from the track list display, the song search menu appears.

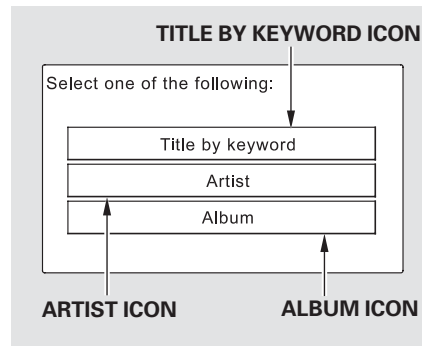

You can then select any of three modes to search a file: Title by Keyword, Artist, and Album.

Playing a PC Card (Models with navigation system)

Searching for a Song Title by Keyword

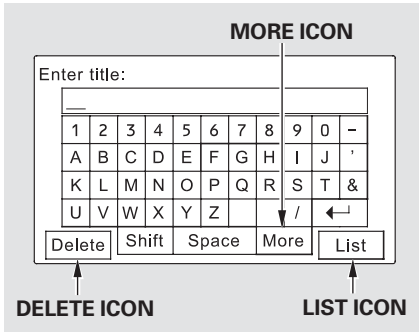

In Title by Keyword mode, enter the title name, or any keyword, by touching the letter icons on the screen. Touch the List icon to begin the song search. If you press the CANCEL button on the screen, the display returns to the mode menu without doing a search.

To cancel the selected letter, select the letter and touch the Delete icon. To select more characters, touch the More icon. The other character list will be shown.

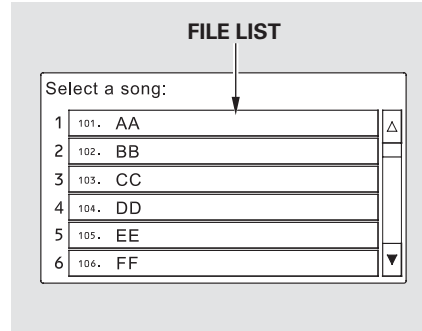

After the system searches for a song, a file list is displayed. To scroll through the list, touch the ▲ or ▼ icon on the side of the screen. Select the desired file by touching the appropriate icon, or moving the joystick and pressing ENT.

Searching for a Song by Artist Name

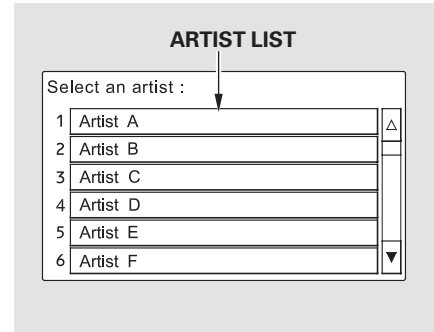

Select the Artist icon, and the artist list appears. Select the desired artist, and the artist's file list is displayed.

CONTINUED

Playing a PC Card (Models with navigation system)

Searching for a Song by Album Name

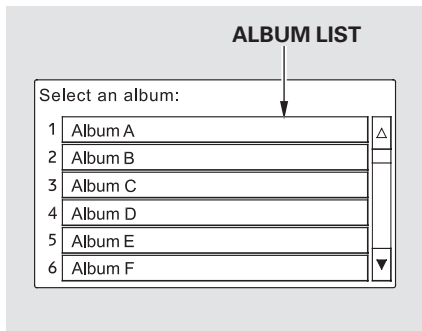

Select the Album icon, and the album list appears. Select the desired album, and its song list is displayed. You can then select the desired song from the list.

To Stop Playing a PC Card

To play the radio when a PC card is playing, press the AM/FM button or touch the FM1, FM2, AM, XM1*, or XM2* icon. If a disc is in the audio unit, press the CD/XM button or touch the CD icon to play the disc. Touch the CARD icon to switch back to the PC card player.

*: If equipped

To play an audio unit connected to the auxiliary input jack or the USB adapter cable when a PC card is playing, touch the AUX or USB icon.

You can also press the MODE button on the steering wheel to change modes.

If you turn the system off while a PC card is playing, either with the power/volume knob or by turning off the ignition switch, the card will stay in the drive. When you turn the

system back on, the card will begin playing where it left off.

When you leave the vehicle, always remove the PC card from the audio unit.

Removing a PC Card

To remove a PC card from the audio unit, fold back the screen by pressing the OPEN button (see page 173). Press the eject button (▲) to remove the card. If you do not remove it from the slot, you cannot return the screen to the upright position.

To return the screen to the upright position, press the CLOSE button.

You can also eject a card when the ignition switch is off.

PC Card Error Messages (Models with navigation system)

If you see an error message in the display while playing a PC card, find the solution in the chart to the right. If you cannot clear the error message, take your vehicle to your dealer.

Error Message	Solution
FILE ERROR	The system cannot read the file(s). Check the files on the PC card. There is a possibility that the files have been damaged.
NO MUSIC	It appears when the PC card is empty or there are no MP3 or WMA files in the PC card. Save the MP3 or WMA files in the PC card.
MEDIA ERROR	It appears when an unsupported PC card is inserted. The system supports CompactFlash card, Flash ATA card, and SanDisk memory Card Adapter.

Playing an iPod® (Models with navigation system)

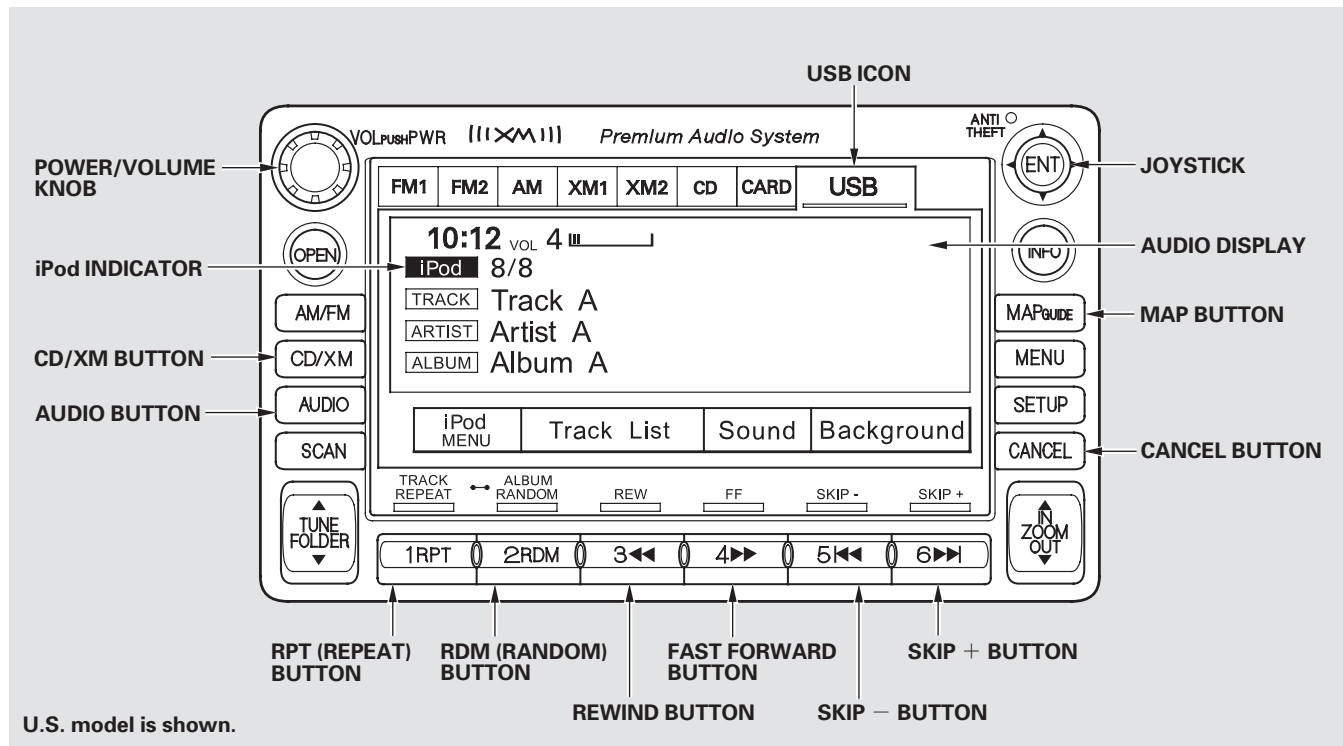

Playing an iPod® (Models with navigation system)

To Play an iPod®

This audio system can select and play the audio files on the iPod® with the same controls used for the in-dash disc player. To play an iPod, connect it to the USB adapter cable in the console compartment by using your dock connector. Press the AUDIO button beside the screen to show the audio display and touch the USB icon. The ignition switch must be in the ACCESSORY (I) or ON (II) position. The iPod will also be recharged with the ignition switch in these positions.

You can also select an icon by moving the joystick. Move it to left, right, up, or down to change the highlighting and scroll through lists, then press ENT on the top of the joystick to set your selection.

To select the USB mode without using the icon, press the CD/XM button repeatedly. The status bar appears on the bottom of the screen.

The audio system reads and plays playable sound files on the iPod. The system cannot operate an iPod as a mass storage device. The system will only play songs stored on the iPod with iTunes.

iPod and iTunes are registered trademarks owned by Apple Inc.

Voice Control System

You can select the AUX mode by using the navigation system voice control buttons, but cannot operate the play mode functions.

iPods compatible with your audio system using the USB adapter cable are:

Model	Software
iPod classic (80/160 G)	Ver. 1.1.2 or more
iPod classic (120 G)	Ver. 2.0.1 or more
iPod with video (iPod 5th generation)	Ver. 1.3.0 or more
iPod nano	Ver. 1.3.1 or more
iPod nano 2nd generation	Ver. 1.1.3 or more
iPod nano 3rd generation	Ver. 1.1.3 or more
iPod nano 4th generation	Ver. 1.0.3 or more
iPod nano 5th generation	Ver. 1.0.1 or more
iPod touch	Ver. 1.1.5 or more
iPod touch 2nd generation	Ver. 2.2.1 or more

CONTINUED

Playing an iPod® (Models with navigation system)

Use only compatible iPods with the latest software. iPods that are not compatible will not work in this audio unit.

NOTE:

- Do not connect your iPod using a hub.
- Do not keep the iPod in the vehicle. Direct sunlight and high heat will damage it.
- Do not use an extension cable between the USB adapter cable equipped with your vehicle and your dock connector.
- We recommend backing up your data before playing it.
- Some devices cannot be powered or charged via the USB adapter. If this is the case, use the accessory adapter to supply power to your device.

Connecting an iPod

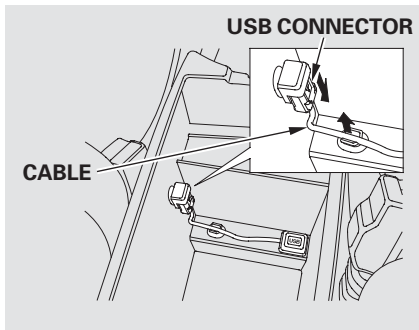

1. Pull out the USB connector from the holder and remove the cable from the clip in the console compartment.

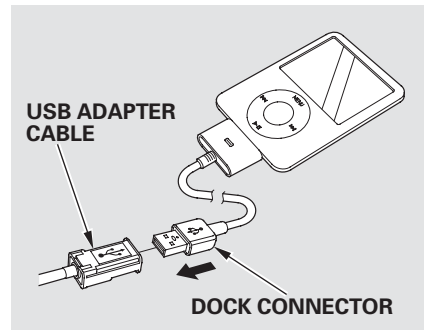

2. Connect your dock connector to the iPod correctly and securely.
3. Install the dock connector to the USB adapter cable securely.

Playing an iPod® (Models with navigation system)

If the iPod indicator does not appear in the audio display, check the connections, and try to reconnect the iPod a few times.

If the audio system still does not recognize the iPod, the iPod may need to be reset. Follow the instructions that came with your iPod, or you can find reset instructions online at www.apple.com/itunes/

When the iPod is connected and the audio display is selected on the screen by pressing the AUDIO button, the AUX icon switches to the USB icon. The display also shows the current file number and total of the selected playable files, the artist, album and track (file) names on the navigation screen.

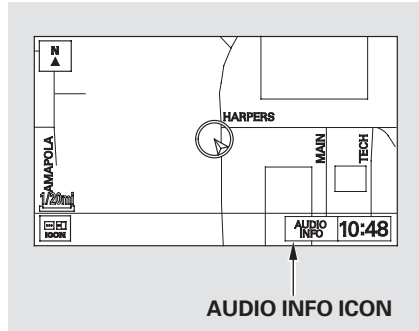

On the map screen, you can see the audio information whenever you touch the AUDIO INFO icon on the lower part of the screen.

To Change or Select Files

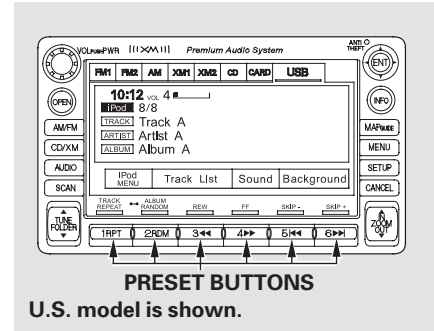

Use the preset buttons while an iPod is playing to select passages and change files. Each preset button's function is shown on the bottom of the screen.

CONTINUED

Playing an iPod® (Models with navigation system)

SKIP — Each time you press and release ►► (preset 6 button), the player skips forward to the beginning of the next file. Press and release ◄◄ (preset 5 button), to skip backward to the beginning of the current file. Press it again to skip to the beginning of the previous file.

FF/REW — To move rapidly within a file, press and hold ►► (preset 4 button) or ◄◄ (preset 3 button).

Using a Track List

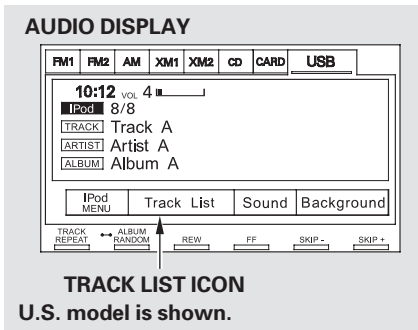

You can also select a file directly from a track list on the audio display. Press the AUDIO button to show the audio display, then touch the Track List icon. The track list menu appears on the display.

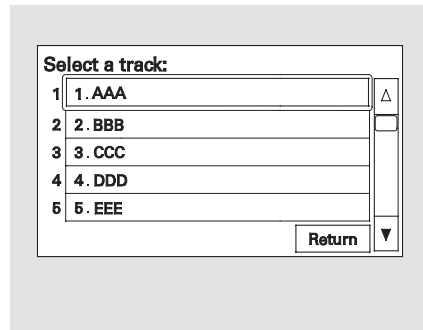

To scroll through the display, touch the ▲ or ▼ icon on the side of the screen. To go back to the previous display, touch the Return icon.

To select a desired icon with the joystick, move it in the appropriate direction, then press ENT.

To Select a File from iPod Menu

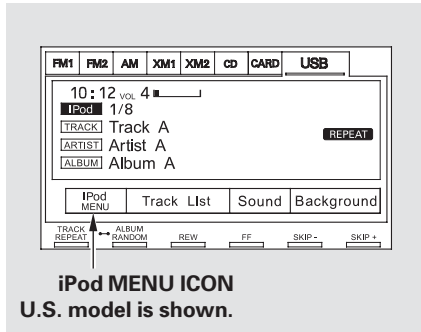

You can also select a file from the iPod menu: playlists, artists, albums and songs. Press the AUDIO button to display the audio display on the navigation screen. Touch the iPod MENU icon to display the iPod menu.

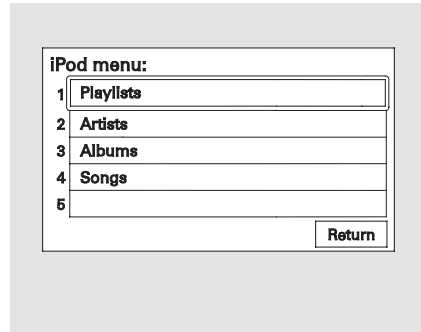

Select a desired list by touching the appropriate icon.

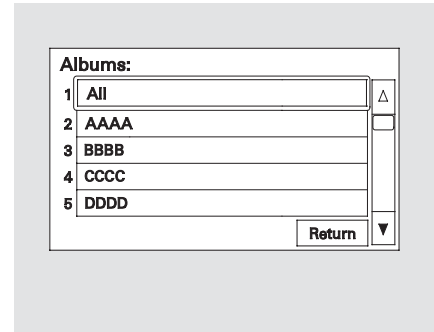

The display shows the items on that list. Touch a desired file.

To scroll through the display, touch the ▲ or ▼ icon on the side of the screen. To go back to the previous display, touch the Return icon.

CONTINUED

Playing an iPod® (Models with navigation system)

To select a desired icon with the joystick, move it in the appropriate direction, then press ENT.

If you select “ALL” on either the artists or albums list, all available files on the selected list are played.

Press the AUDIO button to go back to the normal audio playing display. Pressing the CANCEL button goes back to the previous screen, and pressing the MAP button cancels the audio display on the screen.

To Select Repeat or Random Mode:

You can select any type of repeat and random modes with the RPT and RDM buttons. To confirm the selected mode, press the AUDIO button to show the audio display on the navigation screen.

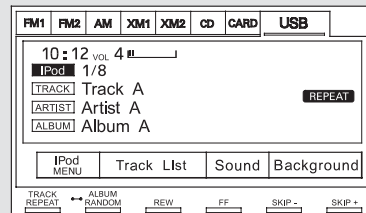

U.S. model is shown.

TRACK REPEAT – This feature continuously plays a track/file. To activate track repeat, press and release the RPT button (preset 1). You will see REPEAT in the display. To turn it off, press and release the RPT button again.

Playing an iPod® (Models with navigation system)

Each time you press and release the RPT button, the mode changes between track repeat and normal play.

Pressing either SKIP button changes the file while keeping this feature.

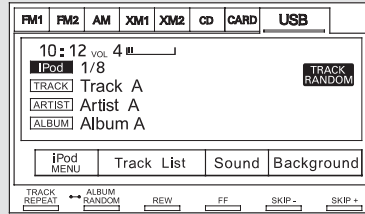

U.S. model is shown.

TRACK RANDOM – This feature plays all available tracks/files from the selected items in the iPod menu list (playlists, artists, albums or songs) in random order. To activate track random, press and release the RDM button (preset 2). You will see TRACK RANDOM on the screen.

ALBUM RANDOM – This feature plays all available albums from the selected item in the iPod menu list (playlists, artists, albums or songs) in random order. The tracks/files in each album are played in the recorded order. To activate album random, press and hold the RDM button (preset 2) until you see ALBUM RANDOM on the screen.

Press and hold the button until you hear a beep to turn off either random mode.

You can also select another list from the iPod menu while keeping the random function.

NOTE:

Available operating functions vary on models or versions. Some functions may not be available on the vehicle's audio system.

Playing an iPod® (Models with navigation system)

To Stop Playing Your iPod

To play the radio, press the AM/FM button or touch the FM1, FM2, AM, XM1*, or XM2* icon. Touch the CD icon to switch to the disc mode (if a disc is loaded). Each time you press the CD/XM button, the audio mode switches between iPod, disc and XM Radio*.

If a PC card is in the audio unit, touch the CARD icon to play the PC card.

You can also press the MODE button on the steering wheel to change modes.

Disconnecting an iPod

You can disconnect the iPod at any time when you see the “OK to disconnect” message* in the iPod display. Always make sure you see the “OK to disconnect” message in the iPod display before you disconnect it. Make sure to follow the iPod’s instructions on how to disconnect the dock connector from the USB adapter cable.

*: The displayed message may vary on models or versions. On some models, there is no message to disconnect.

When you disconnect the iPod while it is playing, the audio screen (if selected) shows NO DATA.

If you reconnect the same iPod, the system may begin playing where it left off, depending on what mode the iPod is in when it is reconnected.

iPod® Error Messages

If you see an error message in the screen, see page 203 .

iPod® Error Messages (Models with navigation system)

If you see an error message on the screen while playing an iPod, find the solution in the chart to the right. If you cannot clear the error message, take your vehicle to your dealer.

Error Message	Cause	Solution
USB ERROR	USB ROM Error	There is problem with the USB adapter unit.
BAD USB DEVICE PLEASE CHECK OWNERS MANUAL	Appears when an incompatible device is connected.	Disconnect the device. Then, turn the audio system off, and turn it on again. Do not reconnect the device that caused the error.
iPod NO SONG	No files in iPod	Appears when the iPod is empty. Store some files in the iPod.
UNSUPPORTED VER.	Use of unsupported iPod	Appears when an unsupported iPod is connected. See page 195 for the specification information for iPods. If it appears when a supported iPod is connected, update the iPod software to the newer version.
CONNECT RETRY	Recognition failure of iPod	Appears when the system dose not acknowledge the iPod. Reconnect the iPod.

Playing a USB Flash Memory Device (Models with navigation system)

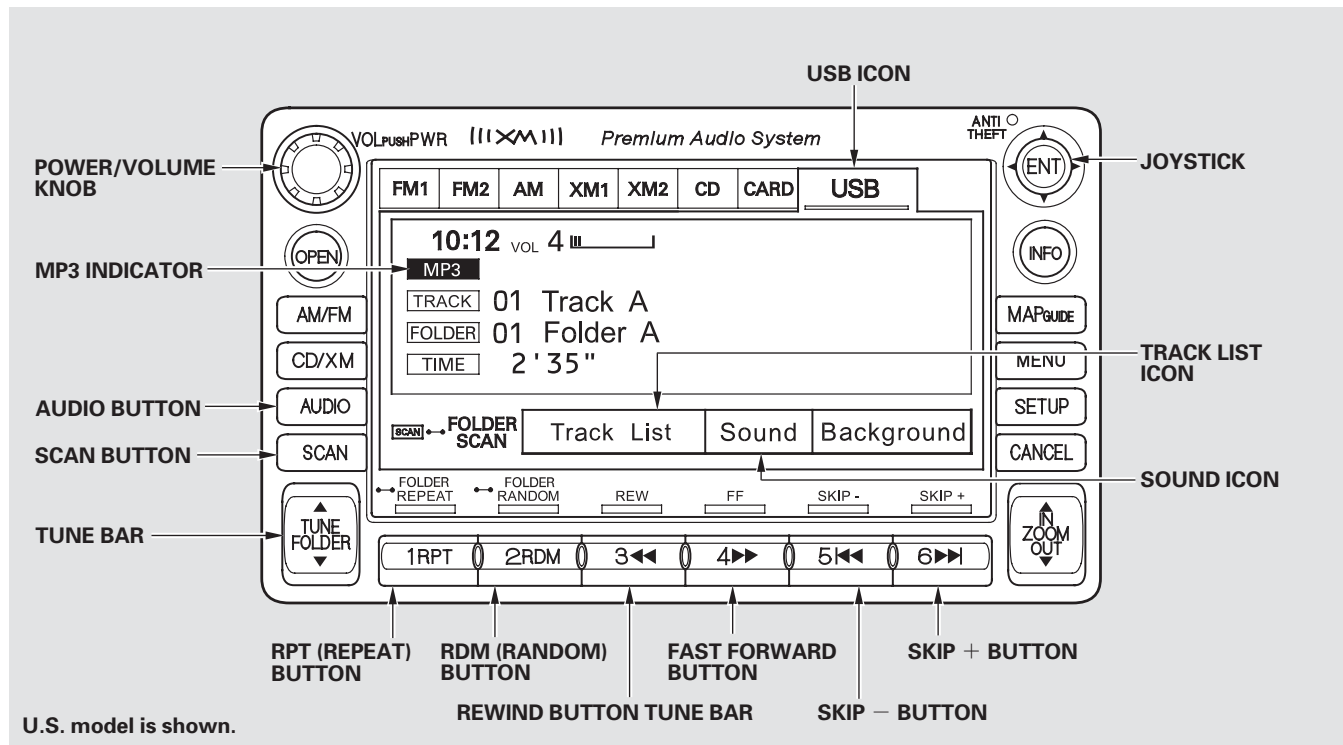

Playing a USB Flash Memory Device (Models with navigation system)

To Play a USB Flash Memory Device

This audio system can select and play the audio files from a USB flash memory device with the same controls used for the in-dash disc player. To play a USB flash memory device, connect it to the USB adapter cable in the console compartment. The ignition switch must be in the ACCESSORY (I) or ON (II) position. Press the AUDIO button beside the screen to show the audio display and touch the USB icon.

You can also select an icon by moving the joystick. Move it to left, right, up, or down to change the highlighting and scroll through lists, then press ENT on the top of the joystick to set your selection.

To select the USB mode without using the icon, press the CD/XM button repeatedly. The status bar appears on the bottom of the screen.

The audio system reads and plays the audio files on the USB flash memory device in MP3, WMA or AAC* formats. Depending on the format, the display shows MP3, WMA or AAC when a USB flash memory device is playing. The USB flash memory device limit is up to 700 folders or up to 65535 files.

* : Only AAC format files recorded with iTunes are playable on this audio unit.

The recommended USB flash memory devices are 256 MB or higher, and formatted with the FAT file system. Some digital audio players may be compatible as well.

Some USB flash memory devices (such as devices with security lock-out features, etc.) will not work in this audio unit.

NOTE:

- Do not use a device such as a card reader or hard drive as the device or your files may be damaged.
- Do not connect your USB flash memory device using a hub.
- Do not use an extension cable to the USB adapter cable equipped with your vehicle.

CONTINUED

Playing a USB Flash Memory Device (Models with navigation system)

- Do not keep a USB flash memory device in the vehicle. Direct sunlight and high heat will damage it.
- We recommend backing up your data before playing a USB flash memory device.
- Some devices cannot be powered or charged via the USB adapter. If this is the case, use the accessory adapter to supply power to your device.
- Depending on the type and number of files, it may take some time before they begin to play.
- Depending on the software the files were made with, it may not be possible to play some files, or display some text data.

- Depending on the type of encoding and writing software used, there may be cases where character information does not display properly.
- The order of files in USB playback may be different from the order of files displayed in PC or other devices etc. Files are played in the order stored in USB flash memory device.

Voice Control System

You can select the AUX mode by using the navigation system voice control buttons, but cannot operate the play mode functions.

Some versions of MP3, WMA, or AAC format may not be supported. If an unsupported file is found, the audio unit displays UNSUPPORTED, then skips to the next file.

In WMA or AAC format, DRM (digital rights management) files cannot be played. If the system finds a DRM file, the screen displays UNPLAYABLE FILE, and then skips to the next file.

NOTICE

Combining a low sampling frequency with a low bitrate may result in extremely degraded sound quality.

Playing a USB Flash Memory Device (Models with navigation system)

Connecting a USB Flash Memory Device

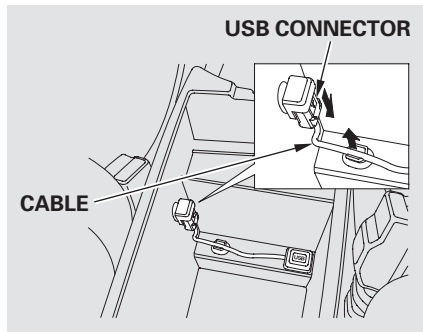

1. Pull out the USB connector from the holder and remove the cable from the clip in the console compartment.

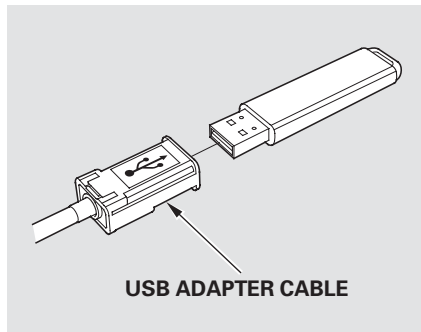

2. Connect the USB flash memory device to the USB adapter cable correctly and securely.

When the USB device is connected and the audio display is selected on the screen by pressing the AUDIO button, the AUX icon switches to the USB icon. The display also shows the folder and file numbers, and the elapsed time.

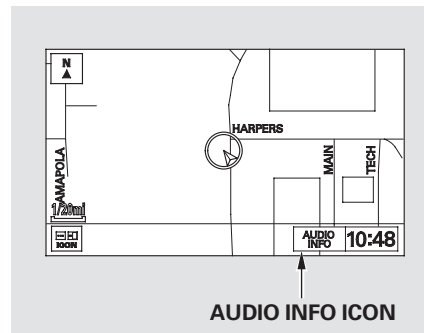

On the map screen, you can see the audio information whenever you touch the AUDIO INFO icon on the lower part of the screen.

CONTINUED

Playing a USB Flash Memory Device (Models with navigation system)

To Change or Select Files

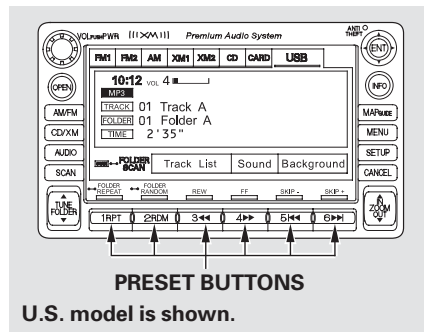

Use the preset buttons while a USB flash memory device is playing to select passages and change files. Each preset button's function is shown on the bottom of the screen.

SKIP — Each time you press and release **▶▶** (preset 6 button), the player skips forward to the beginning of the next file. Press and release **◀◀** (preset 5 button), to skip backward to the beginning of the current file. Press it again to skip to the beginning of the previous file.

FF/REW — To move rapidly within a file, press and hold **▶▶** (preset 4 button) or **◀◀** (preset 3 button).

FOLDER SELECTION — To select a different folder, press either side of the TUNE bar. Press the ▲ side to skip to the next folder, and press the ▼ side to skip to the beginning of the previous folder.

To Select a File from Folder and File Lists

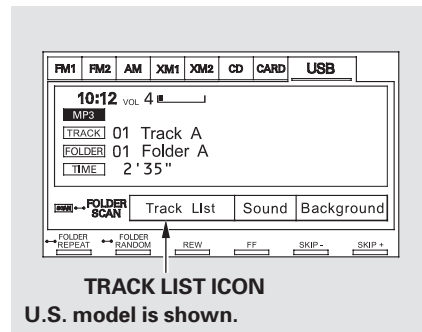

You can also select a folder and file from the lists shown on the screen. Press the AUDIO button to show the audio display on the navigation screen.

Playing a USB Flash Memory Device (Models with navigation system)

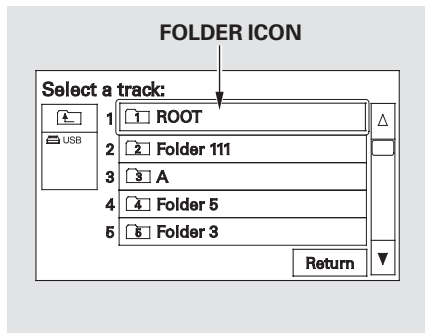

Touch the Track List icon to switch the display to the folder list, then select and touch a desired folder.

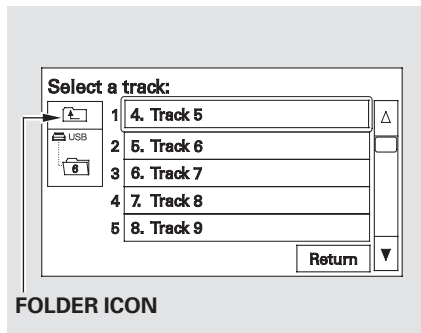

The display changes to the file list. Then, select and touch a desired file.

Touch the folder icon on the upper left of the screen to move to the parent folder.

To scroll through the display, touch the ▲ or ▼ icon on the side of the screen. To go back to the previous display, touch the Return icon.

To select a desired icon with the joystick, move it in the appropriate direction, then press ENT.

Press the AUDIO button to go back to the normal audio playing display. Pressing the CANCEL button goes back to the previous screen, and pressing the MAP button cancels the audio display on the screen.

CONTINUED

Playing a USB Flash Memory Device (Models with navigation system)

To Select Repeat, Random or Scan Mode:

You can select any type of repeat, random and scan modes with the RPT, RDM and SCAN buttons. To confirm the selected mode, press the AUDIO button to show the audio control display on the navigation screen.

TRACK REPEAT – This feature continuously plays a track/file. To activate track repeat, press and release the RPT button (preset 1). You will see TRACK REPEAT in the display.

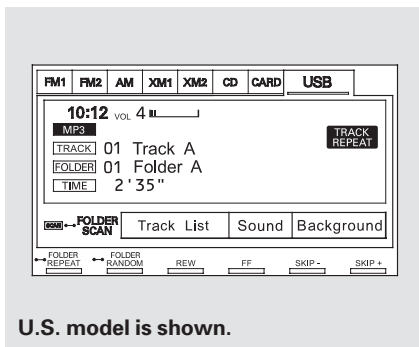

U.S. model is shown.

FOLDER REPEAT – This feature replays all the tracks/files in the selected folder in the order they are stored. To activate folder repeat, press and hold the RPT button (preset 1) until you see FOLDER REPEAT in the display.

Press and hold the button until you hear a beep to turn off either repeat mode. Pressing either side of the TUNE bar also turns off this feature.

Playing a USB Flash Memory Device (Models with navigation system)

TRACK RANDOM – This feature plays all the tracks/files in random order. To activate track random, press and release the RDM button (preset 2). You will see TRACK RANDOM in the display.

FOLDER RANDOM – This feature plays the tracks/files in the selected folder in random order. To activate folder random, press and hold the RDM button (preset 2) until you see FOLDER RANDOM in the display.

Press and hold the button until you hear a beep to turn off either random mode.

TRACK SCAN – This feature samples all tracks/files in the selected folder in the order they are stored. To activate track scan, press and release the SCAN button. You will see TRACK SCAN in the display. You will get a 10 second sampling of each track/file in the folder.

FOLDER-SCAN – This feature samples the first track/file in each folder in the order they are stored. To activate folder scan, press and hold the SCAN button until you see FOLDER SCAN in the display. You will get a 10 second sampling of each first track/file in the folder(s).

Press and hold the button until you hear a beep to turn off either scan mode. Pressing either SKIP button also turns off this feature.

Playing a USB Flash Memory Device (Models with navigation system)

To Stop Playing a USB Flash Memory Device

To play the radio, press the AM/FM button or touch the FM1, FM2, AM, XM1*, or XM2* icon. Press the CD icon to switch to the disc mode (if a disc is loaded). Each time you press the CD/XM button, the audio mode switches between the USB, disc and XM Radio*.

*: If equipped

If a PC card is in the audio unit, touch the CARD icon to play the PC card.

You can also press the MODE button on the steering wheel to change modes.

Disconnecting a USB Flash Memory Device

You can disconnect the USB flash memory device at any time even if the USB mode is selected on the audio system. Make sure to follow the USB flash memory device's instructions when you remove it.

When you disconnect the USB flash memory device while it is playing, the audio display (if selected) shows NO DATA.

If you reconnect the same USB flash memory device, the system will begin playing where it left off.

USB Flash Memory Device Error Messages

If you see an error message in the screen, see page 213.

USB Flash Memory Device Error Messages (Models with navigation system)

If you see an error message on the screen while playing a USB flash memory device, find the solution in the chart to the right. If you cannot clear the error message, take your vehicle to your dealer.

Error Message	Cause	Solution
USB ERROR	USB ROM Error	There is problem with the USB adapter unit.
BAD USB DEVICE PLEASE CHECK OWNERS MANUAL	Appears when an incompatible device is connected.	Disconnect the device. Then, turn the audio system off, and turn it on again. Do not reconnect the device that caused the error.
UNPLAYABLE FILE	Use of unsupported files	Appears when the files in the USB flash memory device are DRM or an unsupported format. This error message appears for about 3 seconds, then plays the next song.
USB NO SONG	No files in USB flash memory device	Appears when the USB flash memory device is empty or there are no MP3, WMA, or AAC files in the USB flash memory device. Save some MP3, WMA, or AAC files in the USB flash memory device.
UNSUPPORTED	Use of unsupported USB flash memory device	Appears when an unsupported device is connected. See page 205 for the specification information for the USB flash memory device. If it appears when the supported device is connected, reconnect the device.

AM/FM Radio Reception

Radio Frequencies

The radio can receive the complete AM and FM bands.

Those bands cover these frequencies:

AM band: 530 to 1,710 kHz

FM band: 87.7 to 107.9 MHz

Radio stations on the AM band are assigned frequencies at least 10 kHz apart (530, 540, 550). Stations on the FM band are assigned frequencies at least 0.2 MHz apart (87.9, 88.1, 88.3).

Stations must use these exact frequencies. It is fairly common for stations to round-off the frequency in their advertising, so your radio could display a frequency of 100.9 even though the announcer may identify the station as “FM101.”

Radio Reception

How well the radio receives stations is dependent on many factors, such as the distance from the station’s transmitter, nearby large objects, and atmospheric conditions.

A radio station’s signal gets weaker as you get farther away from its transmitter. If you are listening to an AM station, you will notice the sound volume becoming weaker, and the station drifting in and out. If you are listening to an FM station, you will see the stereo indicator flickering off and on as the signal weakens. Eventually, the stereo indicator will go off and the sound will fade completely as you get out of range of the station’s signal.

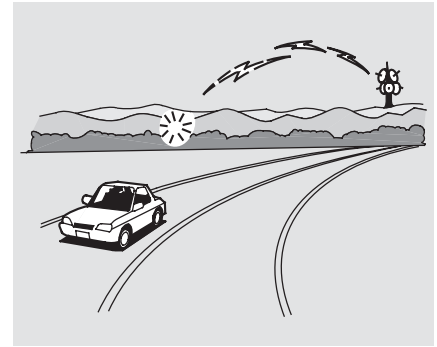

Driving very near the transmitter of a station that is broadcasting on a frequency close to the frequency of the station you are listening to can also affect your radio’s reception. You may temporarily hear both stations, or hear only the station you are close to.

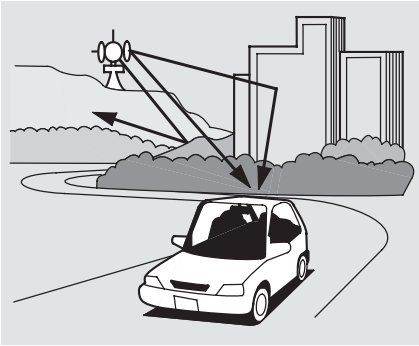

Radio signals, especially on the FM band, are deflected by large objects such as buildings and hills. Your radio then receives both the direct signal from the station's transmitter, and the deflected signal. This causes the sound to distort or flutter. This is a main cause of poor radio reception in city driving.



Radio reception can be affected by atmospheric conditions such as thunderstorms, high humidity, and even sunspots. You may be able to receive a distant radio station one day and not receive it the next day because of a change in conditions.

Electrical interference from passing vehicles and stationary sources can cause temporary reception problems.

*As required by the FCC:
Changes or modifications not expressly approved by the party responsible for compliance could void the user's authority to operate the equipment.*

Protecting Your Discs

General Information

- When using CD-R or CD-RW discs, use only high quality discs labeled for audio use.
- When recording a CD-R or CD-RW, the recording must be closed for it to be used by the system.
- Play only standard round discs. Odd-shaped discs may jam in the drive or cause other problems.
- Handle your discs properly to prevent damage and skipping.

NOTICE

Do not use discs with adhesive labels. The label can curl up and cause the disc to jam in the unit.

Protecting Discs

When a disc is not being played, store it in its case to protect it from dust and other contamination. To prevent warpage, keep discs out of direct sunlight and extreme heat.

To clean a disc, use a clean soft cloth. Wipe across the disc from the center to the outside edge.

A new disc may be rough on the inner and outer edges. The small plastic pieces causing this roughness can flake off and fall on the recording surface of the disc, causing skipping or other problems. Remove these pieces by rubbing the inner and outer edges with the side of a pencil or pen.

Never try to insert foreign objects in the system or the magazine.

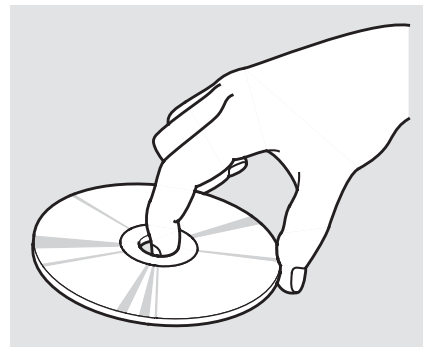

Handle a disc by its edges; never touch either surface. Do not place stabilizer rings or labels on the disc. These, along with contamination from fingerprints, liquids, and felt-tip pens, can cause the disc to not play properly, or possibly jam in the drive.

Additional Information on Recommended Discs

The in-dash disc player/changer has a sophisticated and delicate mechanism. If you insert a damaged disc as indicated in this section, it may become stuck inside and damage the audio unit.

Examples of these discs are shown to the right:

1. Bubbled, wrinkled, labeled, and excessively thick discs

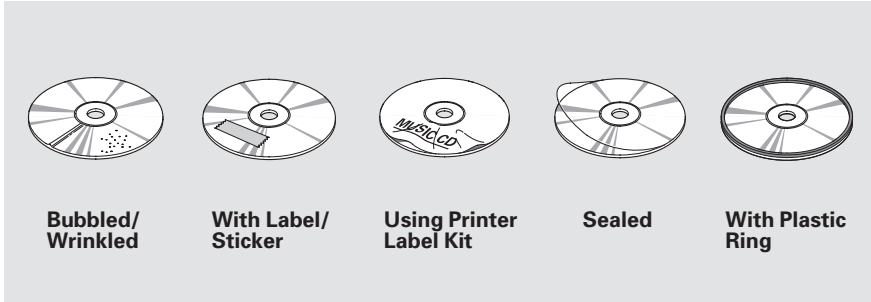

2. Damaged discs

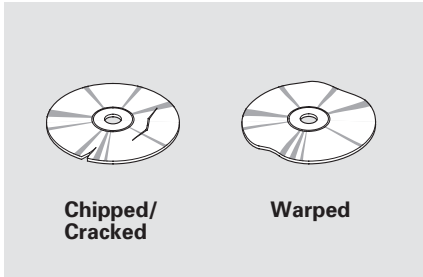

3. Poor quality discs

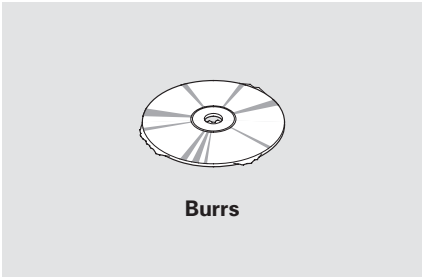

CONTINUED

Features

Protecting Your Discs

4. Small, irregular shaped discs

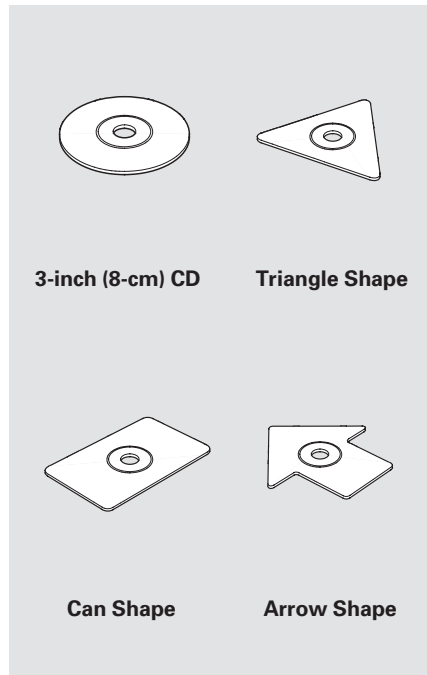

5. Discs with scratches, dirty discs

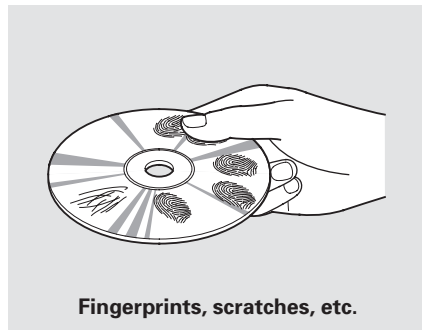

- CD-R or CD-RW may not play due to the recording conditions.
- Scratches and fingerprints on the discs may cause the sound to skip.

- Recommended discs are printed with the following logo.



- Audio unit may not play the following formats.



- This audio unit cannot play a Dual-disc®.

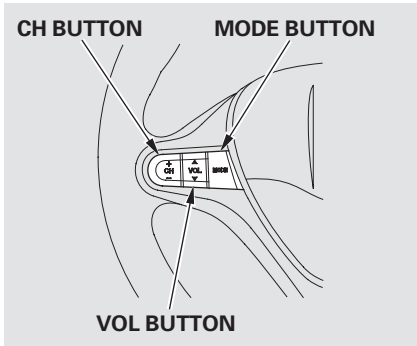

If equipped

Three controls for the audio system are mounted in the steering wheel hub. These let you control basic functions without removing your hand from the wheel.

The VOL button adjusts the volume up (▲) or down (▼). Press the top or bottom of the button, hold it until the desired volume is reached, then release it.

The MODE button changes the mode. Pressing the button repeatedly selects FM1, FM2, AM, disc (if a disc is loaded), or a PC card (if it is loaded). On models with XM Radio, you can also select XM1 and XM2.

If an iPod or a USB flash memory device is plugged into the system, you can also select AUX.

If you are listening to the radio, use the CH button to change stations. Each time you press and release the top (+) of the button, the system goes to the next preset station on the band you are listening to. Press and release the bottom (-) to go back to the previous station.

To activate the seek function, press and hold the top (+) or bottom (-) of the CH button until you hear a beep. The system searches up or down from the current frequency to

find a station with a strong signal.

If you are playing a disc, the system skips to the beginning of the next track (file in MP3 or WMA format) each time you press the top (+) of the CH button. Press the bottom (-) to return to the beginning of the current track or file. Press it twice to return to the previous track or file.

You will see the track/file number and the elapsed time. If the disc has text data or is compressed in MP3 or WMA, you can also see any other information (track title, file name, folder name, etc.).

If you are playing a PC card, press the top (+) of the CH button to advance to the next file. Press the bottom (-) to go back to the previous file.

CONTINUED

Remote Audio Controls, Auxiliary Input Jack

In MP3 or WMA mode, you can use the seek function to select folders. Press and hold the top (+) of the CH button until you hear a beep to skip forward to the first file of the next folder. Press the bottom (-) to skip backward to the previous folder.

If you are playing a USB flash memory device or iPod with the USB adapter cable (if equipped), press and release the top (+) of the CH button to skip forward to the beginning of the next file. Press the bottom (-) to skip backward to the beginning of the current file. Press it twice to return to the previous file.

When playing a USB flash memory device, you can also use the seek function to skip the folder. To activate this, press and hold either side of the CH button until you hear a beep.

Auxiliary Input Jack

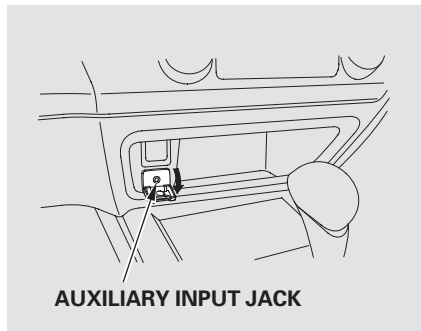

If equipped

The auxiliary input jack is underneath the accessory power socket on the front panel. The system will accept auxiliary input from standard audio accessories using a 1/8 inch (3.5 mm) stereo miniplug.

When a compatible audio unit is connected to the jack, press the AUX button (AUX icon on models with navigation system) to select it.

On models with audio system

Your vehicle's audio system will disable itself if it is disconnected from electrical power for any reason. To make it work again, you must enter a specific code using the preset buttons (icons on vehicle's with navigation system). Because there are hundreds of number combinations possible from specific digits, making the system work without knowing the exact code is nearly impossible.

You should have received a card that lists your audio system's code and serial numbers. It is best to store this card in a safe place at home. In addition, you should write the audio system's serial number in this owner's manual.

If you lose the card, you must obtain the code number from a dealer. To do this, you will need the system's serial number.

If your vehicle's battery is disconnected or goes dead, the audio system will disable itself. If this happens, you will see "ENTER CODE" in the frequency display the next time you turn on the system. Use the preset buttons (icons on vehicles with navigation system) to enter the code. The code is on the radio code card included in your owner's manual kit. When it is entered correctly, the radio will start playing.

If you make a mistake entering the code, do not start over; complete the sequence, then enter the correct code. You have 10 tries to enter the correct code. If you are unsuccessful in 10 attempts, you must then leave the system on for 1 hour before trying again.

The system will retain your AM and FM presets even if power is disconnected.

Setting the Clock

On models without navigation system

To set the time, press the **CLOCK** (AM/FM) button until the displayed time begins to blink, then release the button.

Change the hours by pressing the **H** (preset 1) button until the numbers advance to the desired time. Change the minutes by pressing the **M** (preset 2) button until the numbers advance to the desired time.

Press the **CLOCK** (AM/FM) button again to enter the set time.

You can quickly set the time to the nearest hour. If the displayed time is before the half hour, pressing the **CLOCK** (AM/FM) button until you hear a beep, then pressing the **R** (preset 3) button sets the clock back to the previous hour. If the displayed time is after the half hour, the clock sets forward to the beginning of the next hour.

U.S. LX, and Canadian DX-G and SE models
Optional for U.S. DX model

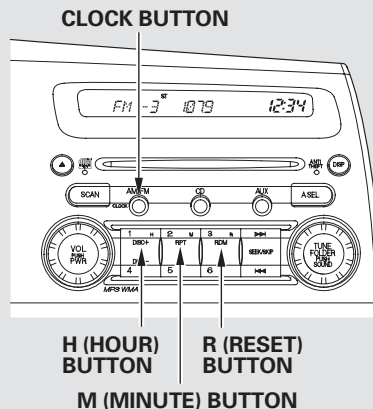

EX, EX-L and Si models

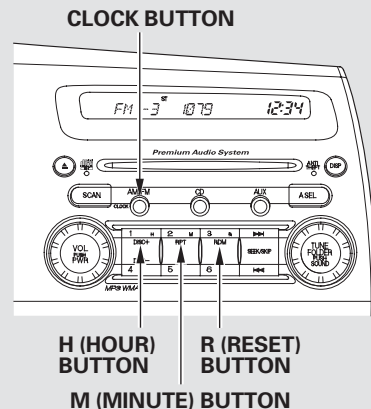

For example: 1:06 will reset to 1:00
1:52 will reset to 2:00

On models with navigation system

The navigation system receives signals from the global positioning system (GPS), and the displayed time is updated automatically by the GPS. Refer to the navigation system manual for how to adjust the time.

If equipped

The security system helps to protect your vehicle and valuables from theft. The horn sounds and a combination of headlights, parking lights, side marker lights, and taillights flashes if someone attempts to break into your vehicle or remove the radio. This alarm continues for 2 minutes, then the system resets. To reset an activated system before the 2 minutes have elapsed, unlock the driver's door with the key or the remote transmitter.

The security system automatically sets 15 seconds after you lock the doors, hood, and trunk. For the system to activate, you must lock the doors from the outside with the key, lock tab, door lock switch, or remote transmitter. The security system indicator on the instrument panel starts blinking immediately to show you the system is setting itself.

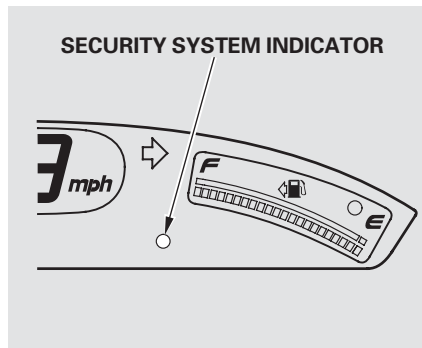

Once the security system is set, opening either door without using the key or the remote transmitter, the hood, or the trunk will cause the alarm to activate. It will also activate if the audio unit is removed from the dashboard or the wiring is cut.

With the system set, you can still open the trunk with the master key (U.S. LX model) or the remote transmitter (U.S. EX, EX-L and Si models) without triggering the alarm.

The alarm will sound if the trunk lock is forced, or the trunk is opened with the trunk release handle or the emergency trunk opener.

The security system will not set if the hood, trunk, or either door is not fully closed. If the system will not set, turn the ignition switch to the ON (II) position, and check the indicators on the instrument panel. Close either door or the trunk indicated on the display. Check the hood visually since it is not part of the display, and shut it if necessary.

NOTE: Use the remote transmitter to quickly check that the hood, the trunk, and both doors are closed. Push the lock button twice within 5 seconds. There should be an audible confirmation beep.

Do not attempt to alter this system or add other devices to it.

Cruise Control

If equipped

Cruise control allows you to maintain a set speed above 25 mph (40 km/h) without keeping your foot on the accelerator pedal. It should be used for cruising on straight, open highways. It is not recommended for city driving, winding roads, slippery roads, heavy rain, or bad weather.

⚠ WARNING

Improper use of the cruise control can lead to a crash.

Use the cruise control only when traveling on open highways in good weather.

Using Cruise Control

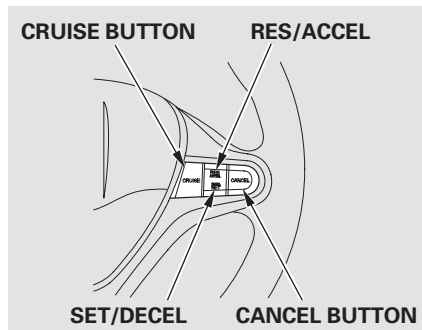

1. Push the CRUISE button on the steering wheel. The CRUISE MAIN indicator on the instrument panel comes on.

The cruise control system can be left on, even when it is not in use.

2. Accelerate to the desired cruising speed above 25 mph (40 km/h).

3. Press and release the SET/DECEL button on the steering wheel. The CRUISE CONTROL indicator on the instrument panel comes on to show the system is now activated.

Cruise control may not hold the set speed when you are going up and down hills. If your vehicle speed increases going down a hill, use the brakes to slow down. This will cancel the cruise control. To resume the set speed, press the RES/ACCEL button. The CRUISE CONTROL indicator on the instrument panel will come back on.

Changing the Set Speed

You can increase the set cruising speed in any of these ways:

- Press and hold the RES/ACCEL button. When you reach the desired cruising speed, release the button.
- Push on the accelerator pedal until you reach the desired cruising speed, then press the SET/DECEL button.
- To increase the speed in very small amounts, tap the RES/ACCEL button. Each time you do this, your vehicle speeds up about 1 mph (1.6 km/h).

You can decrease the set cruising speed in any of these ways:

NOTE: If you need to decrease your speed quickly, use the brakes as you normally would.

- Press and hold the SET/DECEL button. Release the button when you reach the desired speed.
- To slow down in very small amounts, tap the SET/DECEL button. Each time you do this, your vehicle will slow down about 1 mph (1.6 km/h).
- Tap the brake or clutch pedal lightly with your foot. The CRUISE CONTROL indicator on the instrument panel goes out. When the vehicle slows to the desired speed, press the SET/DECEL button.

Even with the cruise control turned on, you can still use the accelerator pedal to speed up for passing. After completing the pass, take your foot off the accelerator pedal. The vehicle will return to the set cruising speed.

Resting your foot on the brake or clutch pedal causes the cruise control to cancel.

Cruise Control

Canceling Cruise Control

You can cancel cruise control in any of these ways:

- Tap the brake or clutch pedal.
- Push the CANCEL button on the steering wheel.
- Push the CRUISE button on the steering wheel.

Resuming the Set Speed

When you push the CANCEL button, or tap the brake or clutch pedal, the system remembers the previously set cruising speed. To return to that speed, accelerate to above 25 mph (40 km/h) and then press and release the RES/ACCEL button. The CRUISE CONTROL indicator comes on, and the vehicle accelerates to the same cruising speed as before.

Pressing the CRUISE button turns the system off and erases the previous cruising speed.

On models with navigation system Bluetooth® HandsFreeLink® (HFL) allows you to place and receive phone calls using voice commands, without handling your cell phone.

To use HFL, you need a Bluetooth-compatible cell phone. For a list of compatible phones, pairing procedures, and special feature capabilities:

In the U.S., visit handsfreelink.honda.com or call (888) 528-7876.

Using HFL HFL Buttons

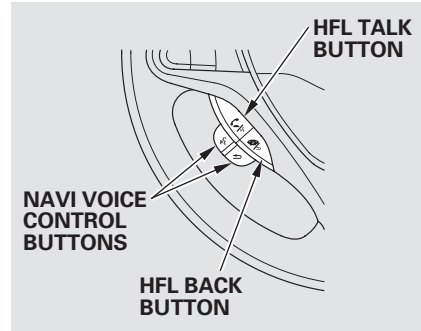

HFL Talk button — Press and release to give a command or answer a call.

HFL Back button — Press and release to end a call, go back to the previous command, or cancel the command.

Voice Control Tips

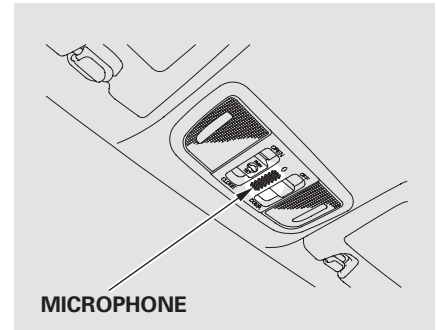

- Air or wind noise from the dashboard and side vents, windows and moonroof may interfere with the microphone. Adjust or close them as necessary.

CONTINUED

- Press and release the HFL Talk button each time you want to make a command. After the beep, speak in a clear, natural tone.
- Try to reduce all background noise. If the microphone picks up voices other than yours, commands may be misinterpreted.

- Many commands can be spoken together. For example, you can say “Call 123-456-# # # #” or “Dial Peter.”
- When HFL is in use, navigation voice commands cannot be recognized.
- To change the volume level of HFL, use the audio system volume knob or the steering wheel volume controls.

Help Features

- To hear general HFL information, including help on pairing a phone or setting up the system, say “Tutorial.”
- For help at any time, including a list of available commands, say “Hands free help.”

Information Display

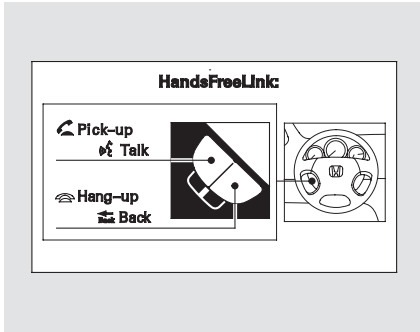

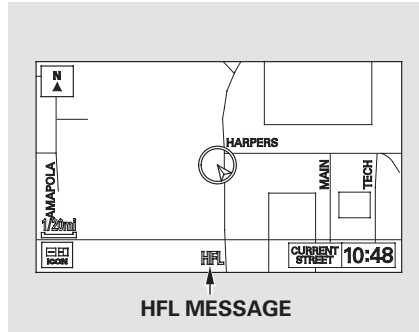

A notification that there is an incoming call, or HFL is in use, will appear on the navigation screen when the audio system is on.

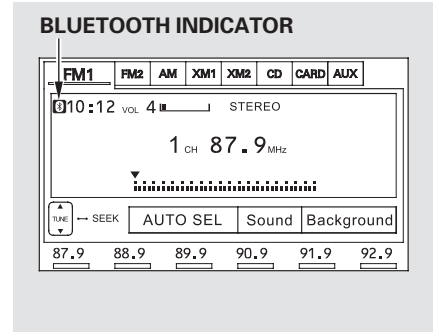

When there is an incoming call, or HFL is in use, “HFL” will appear at the bottom of the map screen.

However, when the current street is shown, and AUDIO INFO icon is visible, “HFL” will not appear when there is an incoming call.



“” indicator will be displayed on the audio display when a phone is linked.

How to Use HFL

The ignition switch must be in the ACCESSORY (I) or ON (II) position.

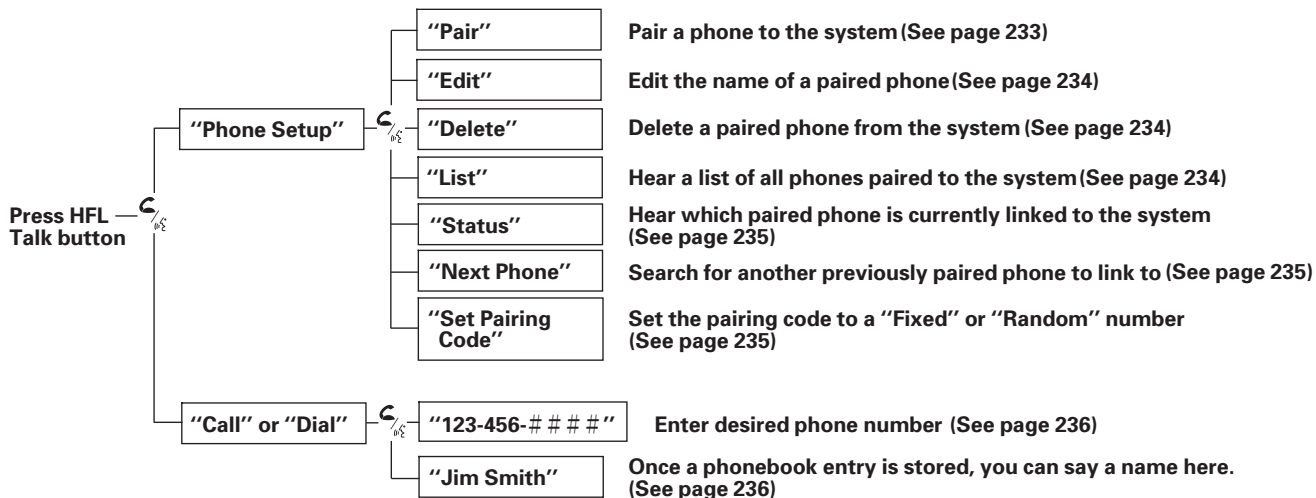

Press and release the HFL Talk button each time you give a command.

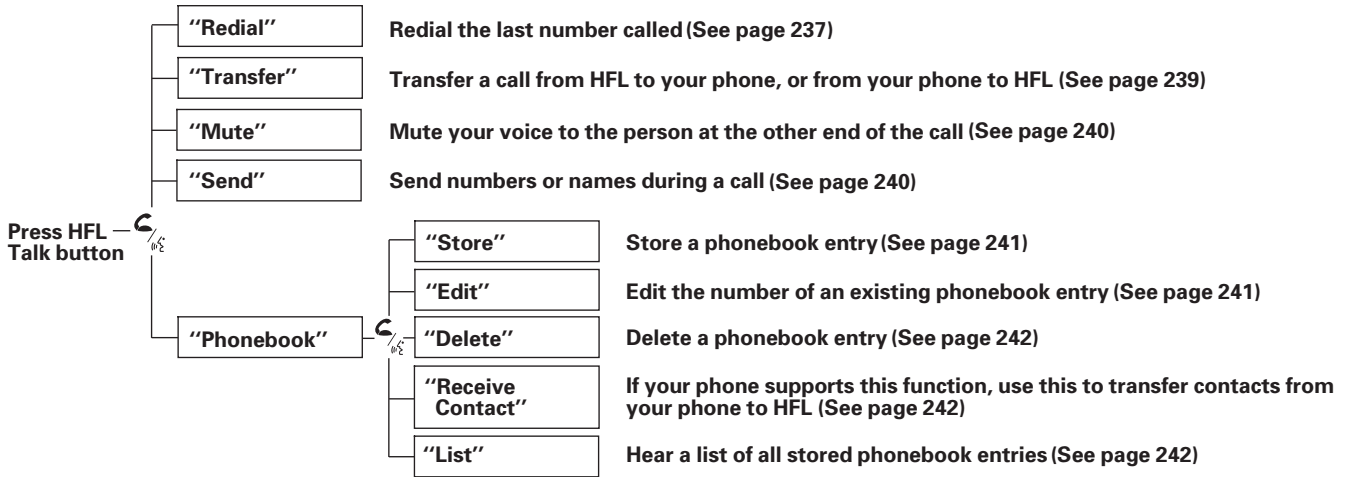

 Press and release the HFL Talk button each time you give a command.

CONTINUED

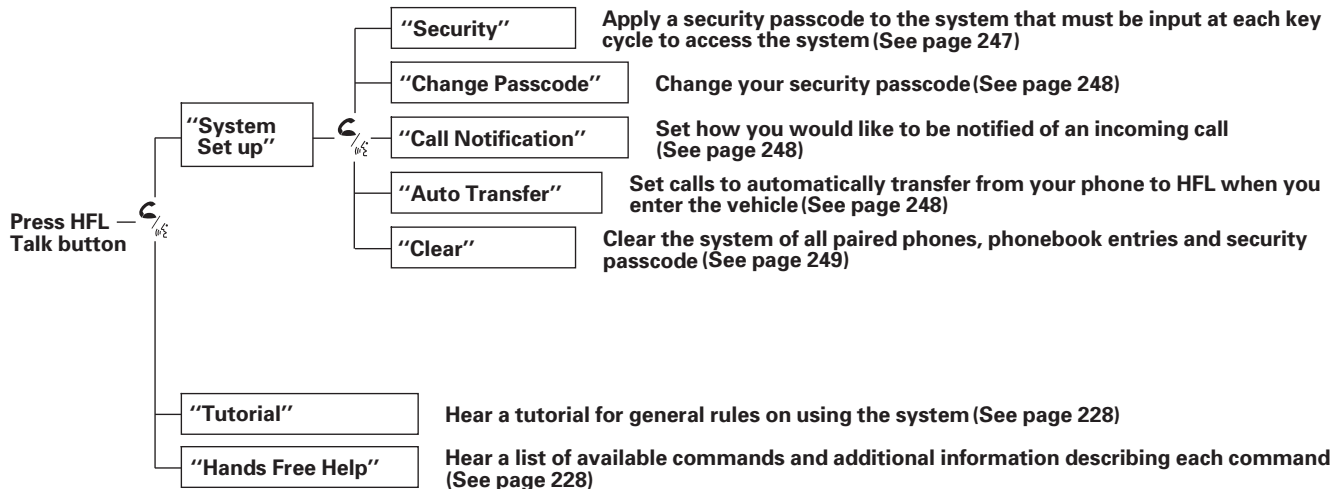

 Press and release the HFL Talk button each time you give a command.

To use HFL, you need to pair your Bluetooth-compatible cell phone to the system.

Phone Setup

This command group is available for paired cell phones.

Phone pairing tips

- You cannot pair your phone while the vehicle is moving.
- Your phone must be in discovery or search mode to pair. Refer to your phone's manual.
- Up to six phones can be paired.
- Your phone's battery may drain faster when it is paired to HFL.
- If after three minutes your phone is not ready to pair or a phone is not found, the system will time out and return to idle.

To pair a cell phone:

1. Press and release the HFL Talk button. If you are pairing a phone for the first time, HFL will give you information about the pairing process. If it is not the first phone you are pairing, say "**Phone setup**" and say "**Pair.**"
2. Follow the HFL prompts and put your phone in discovery or search mode. HFL will give you a 4-digit pairing code and begin searching for your phone.
3. When your phone finds a Bluetooth device, select HFL from the options and enter the 4-digit code from the previous step.
4. Follow the HFL prompts and name the newly paired phone.

CONTINUED

To rename a paired phone:

Press and release the HFL Talk button before a command.

1. Say “**Phone setup.**”
2. Say “**Edit**” after the prompts.
3. If there is more than one phone paired to the system, HFL will ask you which phone’s name you want to change. Follow the HFL prompts and rename the phone.

To delete a paired phone:

Press and release the HFL Talk button before a command.

1. Say “**Phone setup.**”
2. Say “**Delete**” after the prompts.
3. HFL will ask you which phone you want to delete. Follow the HFL prompts to continue with the deletion.

To hear the names of all paired phones:

Press and release the HFL Talk button before a command.

1. Say “**Phone setup.**”
2. Say “**List**” after the prompts.
3. HFL will read out all the paired phone’s names.

To hear which paired phone is currently linked:

Press and release the HFL Talk button before a command.

1. Say “**Phone setup.**”
2. Say “**Status**” after the prompts.
3. HFL will tell you which phone is linked to the system.

To change from the currently linked phone to another paired phone:

Press and release the HFL Talk button before a command.

1. Say “**Phone setup.**”
2. Say “**Next phone**” after the prompts.
3. HFL disconnects the linked phone and searches for another paired phone.
4. Once another phone is found, it is linked to the system. HFL will inform you which phone is now linked.

If no other phones are found or paired, HFL will inform you that the original phone is linked again.

To change the pairing code setting:

Press and release the HFL Talk button before a command.

1. Say “**Phone setup.**”
2. Say “**Set pairing code**” after the prompts.
3. If you want HFL to create a random code each time you pair a phone, say “**Random.**” If you want to choose your own 4-digit code to be used each time, say “**Fixed**” and follow the HFL prompts.

Making a Call

You can make calls using any phone number or a name in the HFL phonebook. You can also redial the last number called.

Bluetooth is the wireless technology that links your phone to HFL. HFL uses a Class 2 Bluetooth, which means the maximum range between your phone and vehicle is 30 feet (10 meters).

During a call, HFL allows you to talk up to 30 minutes after you remove the key from the ignition switch. However, this may weaken the vehicle's battery.

To make a call using a phone number:

Press and release the HFL Talk button before a command.

1. Say **“Call”** or **“Dial.”**
2. Follow the HFL prompts and say the phone number you want to dial.
3. Follow the HFL prompts to confirm the number and say **“Call”** or **“Dial.”**

Once connected, you will hear the person you called through the audio speakers.

To make a call using a name in the HFL phonebook:

Press and release the HFL Talk button before a command.

1. Say **“Call”** or **“Dial.”**
2. Follow the HFL prompts and say the name stored in the HFL phonebook that you want to call.
3. Follow the HFL prompts to confirm the name and make the call.

To redial the last number called by HFL:

Press and release the HFL Talk button and say “**Redial.**”

To make a call from an imported phonebook:

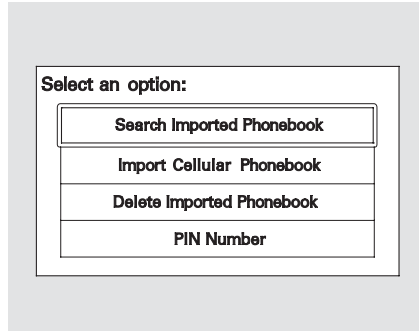

1. Press the INFO button, then select “**Cellular Phonebook.**”
2. Select “**Search Imported Phonebook.**”

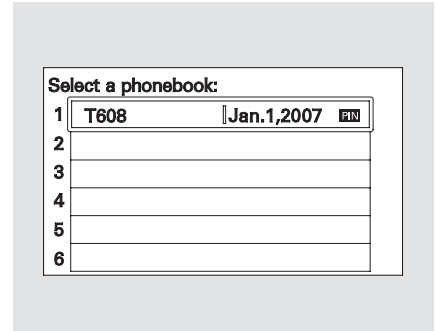

3. Select a phonebook you want to choose a phone number from.

If the phonebook you select is PIN-protected, you will need to enter the PIN to access it. See page 245 for more information.

CONTINUED

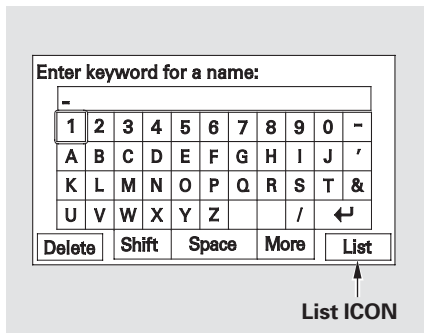

To search for a specific name in the phonebook, enter the keyword for either the first or last name.

To display all names in the phonebook, select the “List” option.

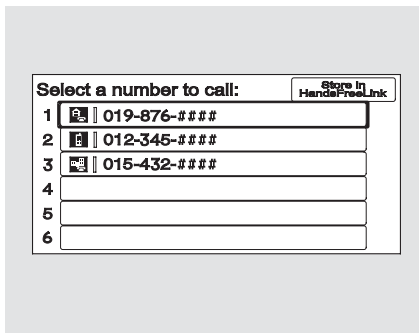

4. Select the name. All the phone numbers stored for that name will be listed.
5. Select the desired number to call from the list.

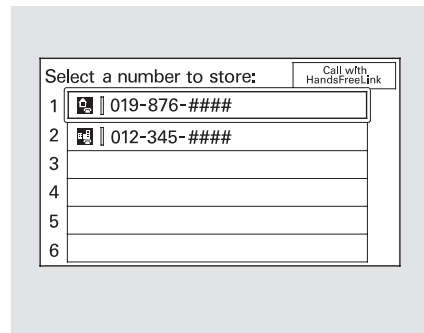

Selecting “Store in HandsFreeLink,” the phone number will be stored in HFL, so that you can call it using HFL’s name tag by voice.

Receiving a Call

When you receive a call, an incoming call notification (if activated) will play and interrupt the audio system if it is on.

Press the HFL Talk button to answer the call, or the HFL Back button to hang up.

Call Waiting

If your phone has Call Waiting, press and release the HFL Talk button to put the original call on hold and answer the incoming call.

To return to the original call, press the HFL Talk button again. If you don't want to answer the incoming call, disregard it and continue with your original call. If you want to hang up the original call and answer the new call, press the HFL Back button.

Transferring a Call

You can transfer a call from HFL to your phone, or from your phone to HFL.

Press and release the HFL Talk button and say “**Transfer.**”

Muting a Call

You can mute your voice to the person you are talking to during a call.

To mute your voice during a call, press and release the HFL Talk button and say “**Mute**.”

To unmute your voice, press and release the HFL Talk button and say “**Mute**” again.

Send Numbers or Names During a Call

HFL allows you to send numbers or names during a call. This is useful when you call a menu-driven phone system.

To send a name or number during a call:

Press and release the HFL Talk button before a command.

1. Say “**Send**.”
2. Follow the HFL prompts and say the name or number you want to send.
3. Follow the HFL prompts to send the tones and continue the call.

NOTE: To send a pound (#), say “pound.” To send a star (*), say “star.”

Phonebook

You can store up to 50 names with their associated numbers in HFL. The numbers you store can be not only phone numbers but other types, such as account numbers or passwords, which can be sent during a menu-driven call.

To store a phonebook entry:

Press and release the HFL Talk button before a command.

1. Say “**Phonebook.**”
2. Say “**Store**” after the prompts.
3. Say a name you want to list as your phonebook entry.
4. Say the number you want to store for the name entry.
5. Follow the HFL prompts and say “**Enter**” to store the entry.

NOTE:

- Avoid using duplicate name entries.
- Avoid using “home” as a name entry.
- It is easier for HFL to recognize a multisyllabic or longer name. For example, use “Peter” instead of “Pete,” or “John Smith” instead of “John.”

To edit the number stored in a name:

Press and release the HFL Talk button before a command.

1. Say “**Phonebook.**”
2. Say “**Edit**” after the prompts.
3. Follow the HFL prompts and say the name entry you want to edit.
4. When asked, say the new number for that name.
5. Follow the HFL prompts to complete the edit.

CONTINUED

To delete a name:

Press and release the HFL Talk button before a command.

1. Say “**Phonebook.**”
2. Say “**Delete**” after the prompts.
3. Say the name you want to delete and follow the HFL prompts to complete the deletion.

To list all names in the phonebook:

Press and release the HFL Talk button before a command.

1. Say “**Phonebook.**”
2. Say “**List**” after the prompts.
3. HFL begins reading the names in the order they were stored.
4. If you hear a name you want to call, immediately press the HFL Talk button and say “**Call.**”

To store a specific phone number from your cell phone directly to the HFL phonebook (available on some phones):

Press and release the HFL Talk button before a command.

1. Say “**Phonebook.**”
2. Say “**Receive contact**” after the prompts.
3. Follow the HFL prompts, select a number from your cell phone, and send it to HFL.
4. Follow the HFL prompts and name the number, or say “**Discard**” if it is not the number you want to store.
5. Follow the HFL prompts if you want to store another number.

Cellular Phonebook

(available on some phones)

If you select **Cellular Phonebook** from the Information screen menu, you will see four HFL options.

For a list of cell phones that are compatible with this feature:

In the U.S., visit handsfreelink.honda.com or call (888) 528-7876.

Import Cellular Phonebook:

The entire phonebook data of the cell phone that is linked to HFL can be imported to the navigation system.

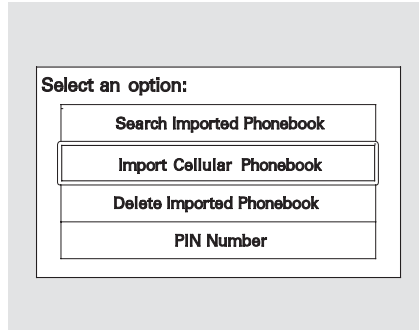

Select **“Import Cellular Phonebook,”** and HFL will begin importing the phonebook. Select **“OK”** after the import is completed.

Search Imported Phonebook:

Once a phonebook has been imported, you can search the phone numbers by the person’s name.

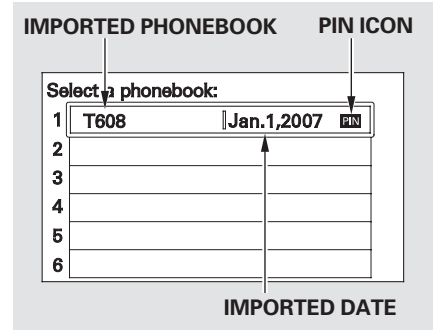

Select **“Search Imported Phonebook,”** and a list of imported phonebooks will be displayed.

Select a phonebook from the list.

CONTINUED

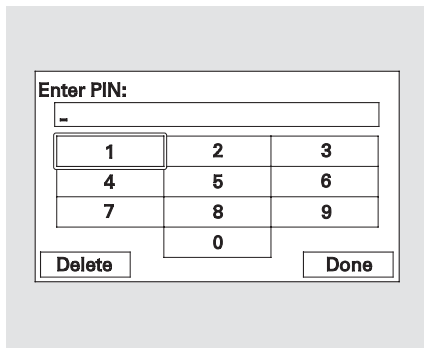

If the phonebook is PIN-protected, you will need to enter the 4-digit PIN.

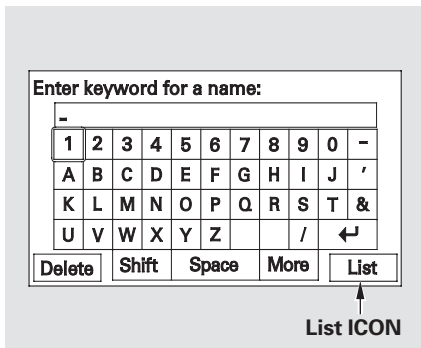

To search for a specific name in the phonebook, enter the keyword for either the first or last name.

To display all names in the phonebook, select the “**List**” option.

Select a person from the list. Up to three category icons are displayed in the left side of the list:



These indicate how many numbers are stored for the name. If a name has more than three category icons, “...” is displayed.

Select the person’s number you want to call, and press the HFL Talk button.

Delete Imported Phonebook:

You can delete any imported phonebook.

Select “**Delete Imported Phonebook**,” and a list of imported phonebooks will be displayed.

Select a phonebook you want to delete. If the phonebook is PIN-protected, you will need to enter the 4-digit PIN number.

After making a selection, the following screen will appear.

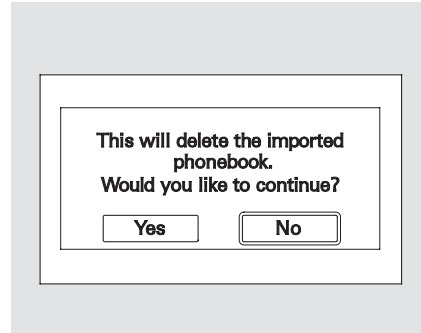

Select “**Yes**,” then “**OK**” to complete the deletion.

PIN Number

You can add, change, or remove a PIN number from any phonebook.

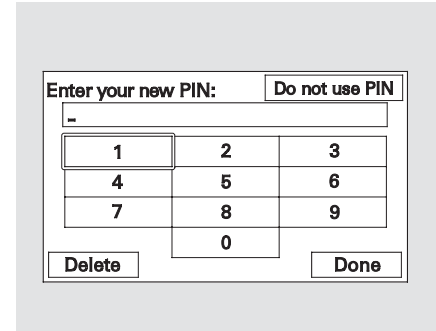
**To add a PIN:**

If you have selected a phonebook without a PIN, you will see the above display.

Enter the new 4-digit PIN. You will have to re-enter the PIN for confirmation.

CONTINUED

To change the PIN to a new number:

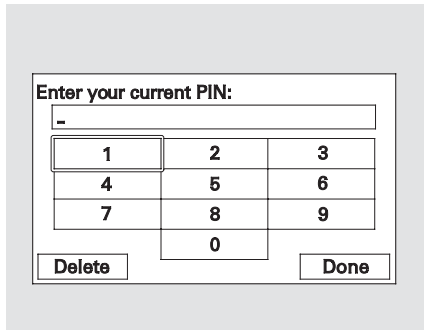

Select the phonebook you want. The display will change as shown above.

Enter the current PIN for this phonebook.

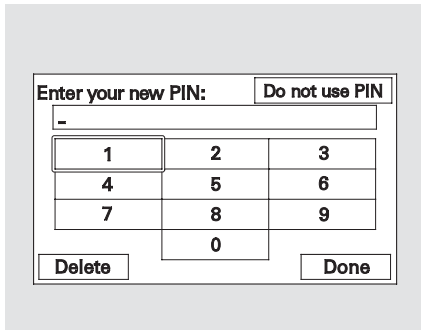

The display will change as shown above.

Enter the new 4-digit PIN number. You will be asked to re-enter the PIN for verification.

To remove a PIN:

Select "PIN number," then select "Do not use PIN" after you enter the current PIN.

System Setup

This command group allows you to change or customize HFL basic settings.

To set a 4-digit passcode to lock the HFL system for security purposes: Press and release the HFL Talk button before a command.

1. Say “**System setup.**”
2. Say “**Security**” after the prompts.
3. Follow the HFL prompts and say the 4-digit passcode you want to set.
4. Follow the HFL prompts to confirm the number.

NOTE: Once a passcode is set, you will need to enter it to use HFL each time you start the vehicle. If you forget the code, your dealer will have to reset it for you, or you will have to clear the entire system (see page 249).

CONTINUED

To change your security passcode:

Press and release the HFL Talk button before a command.

1. Say “**System setup.**”
2. Say “**Change passcode**” after the prompts.
3. Follow the HFL prompts and say the new 4-digit passcode.
4. Follow the HFL prompts to confirm the number.

To select either a ring tone or a prompt as the incoming call notification :*

Press and release the HFL Talk button before a command.

1. Say “**System setup.**”
2. Say “**Call notification**” after the prompts.
3. Follow the HFL prompts and say “**Ring tone**” or “**Prompt.**” You can also say “**Off**” for no audible incoming call notification.

* : The default setting is a ring tone.

To activate or deactivate the auto transfer function:

If you get into the vehicle while you are on the phone, the call can be automatically transferred to HFL with the ignition switch in the ACCESSORY (I) or ON (II) position.

Press and release the HFL Talk button before a command.

1. Say “**System setup.**”
2. Say “**Auto transfer**” after the prompts.
3. HFL will let you know if auto transfer is on or off, depending on the previous setting. Follow the HFL prompts to change the setting.

To clear the system:

This operation clears the passcodes, paired phones, all names in the HFL phonebook, and all imported phonebook data.

Press and release the HFL Talk button before a command.

1. Say “**System setup.**”
2. Say “**Clear**” after the prompts.
3. Follow the HFL prompts to continue to complete the clearing procedure.

You can also clear the system when you have forgotten the passcode and cannot access HFL. When HFL asks you for the passcode, say “**System clear.**” Paired phones, all names in the HFL phonebook and all imported phonebook data will be lost.

Bluetooth® Wireless Technology

The *Bluetooth*® name and logos are registered trademarks owned by Bluetooth SIG, Inc. and any use of such marks by Honda Motor Co., Ltd. is under license. Other trademarks and trade names are those of their respective owners.

As required by the FCC:

This device complies with Part 15 of the FCC rules. Operation is subject to the following two conditions: (1) This device may not cause harmful interference, and (2) this device must accept any interference received, including interference that may cause undesired operation.

Changes or modifications not expressly approved by the party responsible for compliance could void the user’s authority to operate the equipment.

Before you begin driving your vehicle, you should know what gasoline to use and how to check the levels of important fluids. You also need to know how to properly store luggage or packages. The information in this section will help you. If you plan to add any accessories to your vehicle, please read the information in this section first.

Break-in Period	252
Fuel Recommendation	252
Service Station Procedures	253
Refueling	253
Opening and Closing the Hood	254
Oil Check	255
Engine Coolant Check	257
Fuel Economy	258
Accessories and Modifications	261
Carrying Cargo	263

Break-in Period, Fuel Recommendation

Break-in Period

Help assure your vehicle's future reliability and performance by paying extra attention to how you drive during the first 600 miles (1,000 km). During this period:

- Avoid full-throttle starts and rapid acceleration.
- Do not change the oil until the scheduled maintenance time.
- Avoid hard braking for the first 200 miles (300 km).

You should also follow these recommendations with an overhauled or exchanged engine, or when the brakes are replaced.

Fuel Recommendation

All models except Si

Your vehicle is designed to operate on unleaded gasoline with a pump octane number of 87 or higher. Use of a lower octane gasoline can cause a persistent, heavy, metallic rapping noise that can lead to engine damage.

Si model only

Your vehicle is designed to operate on premium unleaded gasoline with a pump octane number of 91 or higher. Use of a lower octane gasoline can cause occasional metallic knocking noises in the engine and will result in decreased engine performance. Use of a gasoline with a pump octane number less than 87 can lead to engine damage.

You may hear a knocking noise from the engine if you drive the vehicle at low engine speed (below about 1,000 rpm) in a higher gear. To stop this, raise the engine speed by shifting to a lower gear.

We recommend using quality gasolines containing detergent additives that help prevent fuel system and engine deposits.

In addition, in order to maintain good performance, fuel economy, and emissions control, we strongly recommend, in areas where it is available, the use of gasoline that does NOT contain manganese-based fuel additives such as MMT.

Use of gasoline with these additives may adversely affect performance, and cause the malfunction indicator lamp on your instrument panel to come on. If this happens, contact your authorized dealer for service.

Some gasoline today is blended with oxygenates such as ethanol or MTBE. Your vehicle is designed to operate on oxygenated gasoline containing up to 10% ethanol by volume and up to 15% MTBE by volume. Do not use gasoline containing methanol.

If you notice any undesirable operating symptoms, try another service station or switch to another brand of gasoline.

For further important fuel-related information for your vehicle, or information on gasoline that does not contain MMT, visit Owner Link at owners.honda.com. In Canada, visit www.honda.ca for additional information on gasoline.

Refueling

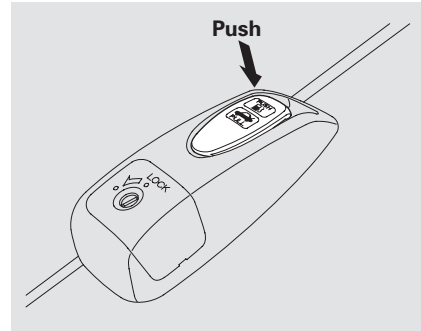

1. Park with the driver's side closest to the service station pump.
2. Open the fuel fill door by pushing on the handle to the left of the driver's seat.

⚠ WARNING

Gasoline is highly flammable and explosive. You can be burned or seriously injured when handling fuel.

- Stop the engine, and keep heat, sparks, and flame away.
- Handle fuel only outdoors.
- Wipe up spills immediately.

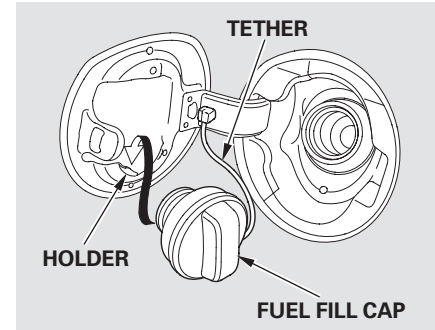

CONTINUED

Service Station Procedures

3. Remove the fuel fill cap slowly. You may hear a hissing sound as pressure inside the tank equalizes. The fuel fill cap is attached to the fuel filler with a tether. Place the cap in the holder on the fuel fill door.
4. Stop filling the tank after the fuel nozzle automatically clicks off. Do not try to “top off” the tank. This leaves some room in the fuel tank for the fuel to expand with temperature changes.

If the fuel nozzle keeps clicking off even though the tank is not full, there may be a problem with your vehicle’s fuel vapor recovery system. The system helps keep fuel vapor from going into the atmosphere. Try filling at another pump. If this does not fix the problem, consult your dealer.

5. Screw the fuel fill cap back on until it clicks at least once. If you do not properly tighten the cap, the malfunction indicator lamp may come on (see page 350). You will also see a “CHECK FUEL CAP” message on the information display.
6. Push the fuel fill door closed until it latches.

Opening and Closing the Hood

HOOD RELEASE HANDLE

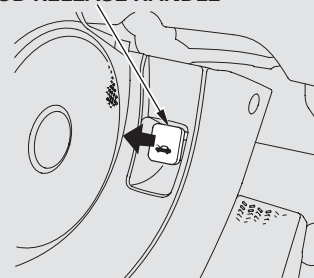

1. Park the vehicle, and set the parking brake. Pull the hood release handle under the lower left corner of the dashboard. The hood will pop up slightly.

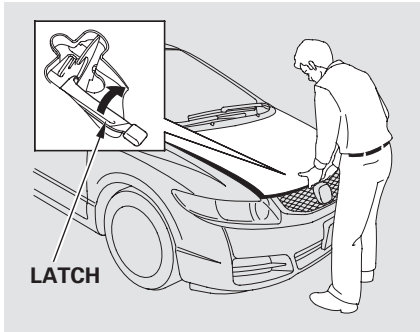

2. Put your fingers under the front edge of the hood near the center. Slide your hand to the left until you feel the hood latch handle. Push this handle up to release it. Lift up the hood.

If the hood latch handle moves stiffly, or if you can open the hood without lifting the handle, the mechanism should be cleaned and lubricated.

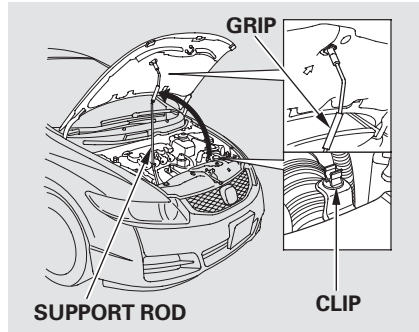

3. Holding the grip, pull the support rod out of its clip. Insert the end into the hole in the hood designated by an arrow.

To close the hood, lift it up slightly to remove the support rod from the hole. Put the support rod back into its holding clip. Lower the hood to about a foot (30 cm) above the fender, then let it drop. Make sure it is securely latched.

Oil Check

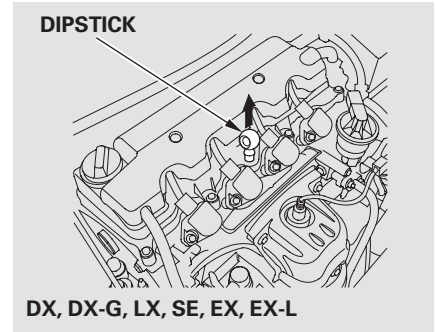

Wait a few minutes after turning the engine off before you check the oil.

1. Remove the dipstick (orange handle).
2. Wipe off the dipstick with a clean cloth or paper towel.
3. Insert the dipstick all the way back into its hole.

CONTINUED

Service Station Procedures

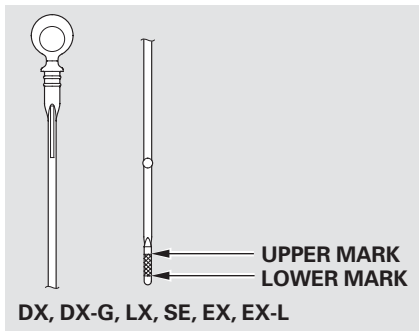
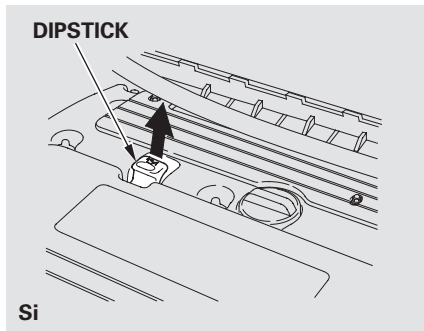

4. Remove the dipstick again, and check the level. It should be between the upper and lower marks.

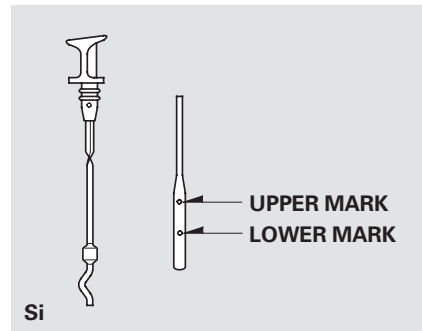

If it is near or below the lower mark, see **Adding Engine Oil** on page 300 .

Engine Coolant Check

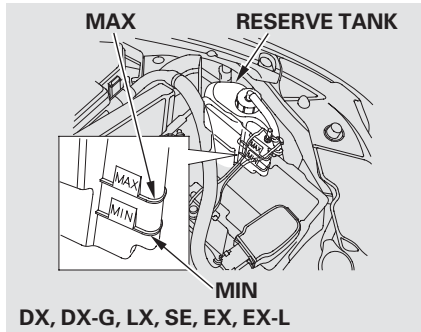

Look at the coolant level in the radiator reserve tank. Make sure it is between the MAX and MIN lines. If it is below the MIN line, see **Adding Engine Coolant** on page 304 for information on adding the proper coolant.

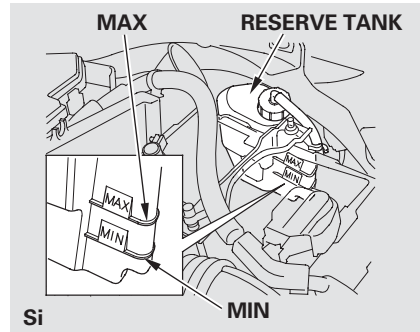

Refer to **Owner's Maintenance Checks** on page 296 for information about checking other items on your vehicle.

Fuel Economy

Actual Mileage and EPA Fuel Economy Estimates Comparison.

Fuel economy is not a fixed number. It varies based on driving conditions, driving habits, and vehicle condition. Therefore, it is not possible for one set of estimates to predict fuel economy precisely for all drivers in all environments.

The EPA fuel economy estimates shown in the example to the right are a useful tool for comparison when buying a vehicle. EPA estimates include:

City MPG – Represents urban driving in light traffic. A range of miles per gallon achieved is also provided.

Highway MPG – Represents a mixture of rural and interstate driving, in a warmed-up vehicle, typical of longer trips in free-flowing traffic. A range of miles per gallon

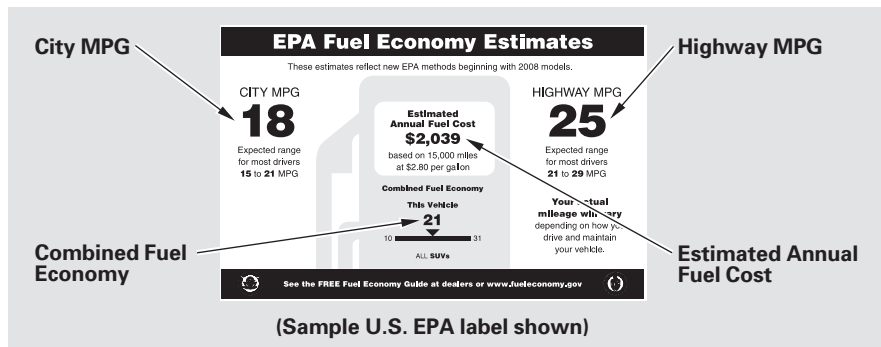

achieved is also provided.

Combined Fuel Economy – Represents a combination of city and highway driving. The scale represents the range of combined fuel economy for other vehicles in the class.

Estimated Annual Fuel Cost – Provides an estimated annual fuel cost, based on 15,000 miles (20,000 km) per year multiplied by the cost

per gallon (based on EPA fuel cost data) divided by the combined fuel economy.

For more information on fuel economy ratings and factors that affect fuel economy, visit www.fueleconomy.gov (Canada: Visit www.vehicles.gc.ca)

Fuel Economy Factors

The following factors can lower your vehicle's fuel economy:

- Aggressive driving (hard acceleration and braking)
- Excessive idling, accelerating and braking in stop-and-go traffic
- Cold engine operation (engines are more efficient when warmed up)
- Driving with a heavy load or the air conditioner running
- Improperly inflated tires

Improving Fuel Economy

Vehicle Maintenance

A properly maintained vehicle maximizes fuel economy. Poor maintenance can significantly reduce fuel economy. Always maintain your vehicle according to the maintenance messages displayed on the information display (see **Owner's Maintenance Checks** on page 296). For example:

- **Use the recommended viscosity motor oil, displaying the API Certification Seal (see page 300).**
- **Maintain proper tire inflation** — An underinflated tire increases “rolling resistance,” which reduces fuel economy.
- **Avoid carrying excess weight in your vehicle** — It puts a heavier load on the engine, increasing fuel consumption.
- **Keep your vehicle clean** — In particular, a build-up of snow or mud on your vehicle's underside adds weight and rolling resistance. Frequent cleaning helps your fuel economy.

Drive Efficiently

- **Drive moderately** — Rapid acceleration, abrupt cornering, and hard braking increase fuel consumption.
- **Observe the speed limit** — Aerodynamic drag has a big effect on fuel economy at speeds above 45 mph (75 km/h). Reduce your speed and you reduce the drag. Trailers, car top carriers, roof racks and bike racks are also big contributors to increased drag.
- **Always drive in the highest gear possible** — If your vehicle has a manual transmission, you can boost your fuel economy by up shifting as early as possible.
- **Avoid excessive idling** — Idling results in 0 miles per gallon (0 kms per liter).

CONTINUED

Fuel Economy

- **Minimize the use of the air conditioning system** – The A/C puts an extra load on the engine which makes it use more fuel. Use the fresh-air ventilation when possible.
- **Plan and combine trips** – Combine several short trips into one. A warmed-up engine is more fuel efficient than a cold one.

Calculating Fuel Economy

Measuring Techniques

Direct calculation is the recommended source of information about your actual fuel economy. Using frequency of fill-ups or taking fuel gauge readings are NOT accurate measures of fuel economy. Fuel economy may improve over the first several thousand miles (kilometers).

Checking Your Fuel Economy

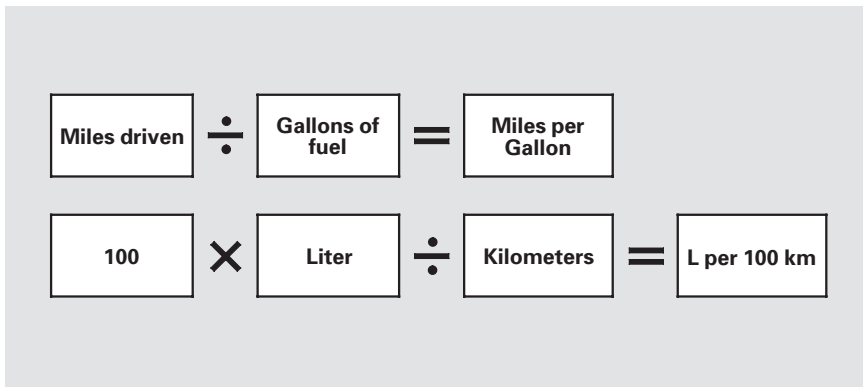

- 1) Fill the fuel tank until the nozzle automatically clicks off.
- 2) Reset trip counter to zero.
- 3) Record the total gallons (liters) needed to refill.
- 4) Follow one of the simple calculations above.

Modifying your vehicle, or installing some non-Honda accessories, can make your vehicle unsafe. Before you make any modifications or add any accessories, be sure to read the following information.

Accessories

Your dealer has Honda accessories that allow you to personalize your vehicle, or improve its performance. These accessories have been designed and approved for your vehicle, and are covered by warranty.

Although non-Honda accessories may fit on your vehicle, they may not meet factory specifications, and could adversely affect your vehicle's handling, stability, and reliability.

⚠ WARNING

Improper accessories or modifications can affect your vehicle's handling, stability, and performance, and cause a crash in which you can be hurt or killed.

Follow all instructions in this owner's manual regarding accessories and modifications.

When properly installed, cellular phones, alarms, two-way radios, and low-powered audio systems should not interfere with your vehicle's computer controlled systems, such as your airbags, anti-lock brakes, and tire pressure monitoring system (if equipped).

Before installing any accessory:

- Make sure the accessory does not obscure any lights, or interfere with proper vehicle operation or performance.
- Be sure electronic accessories do not overload electrical circuits (see page 352) or interfere with the proper operation of your vehicle.
- Before installing any electronic accessory, have the installer contact your dealer for assistance. If possible, have your dealer inspect the final installation.
- Do not install accessories on the side pillars or across the rear windows. Accessories installed in these areas may interfere with proper operation of the side curtain airbags.

Accessories and Modifications

Modifying Your Vehicle

Removing parts from your vehicle, or replacing components with non-Honda components could seriously affect your vehicle's handling, stability, and reliability.

Some examples are:

- Lowering the vehicle with a non-Honda suspension kit that significantly reduces ground clearance can allow the undercarriage to hit speed bumps or other raised objects, which could cause the airbags to deploy.
- Raising your vehicle with a non-Honda suspension kit can affect the handling, stability, and reliability.

- Non-Honda wheels, because they are a universal design, can cause excessive stress on suspension components and will not be compatible with the tire pressure monitoring system (TPMS)*.

* : If equipped

- Larger or smaller wheels and tires can interfere with the operation of your vehicle's anti-lock brakes and other systems.
- Modifying your steering wheel or any other part of your vehicle's safety features can make the systems ineffective.

If you plan to modify your vehicle, consult your dealer.

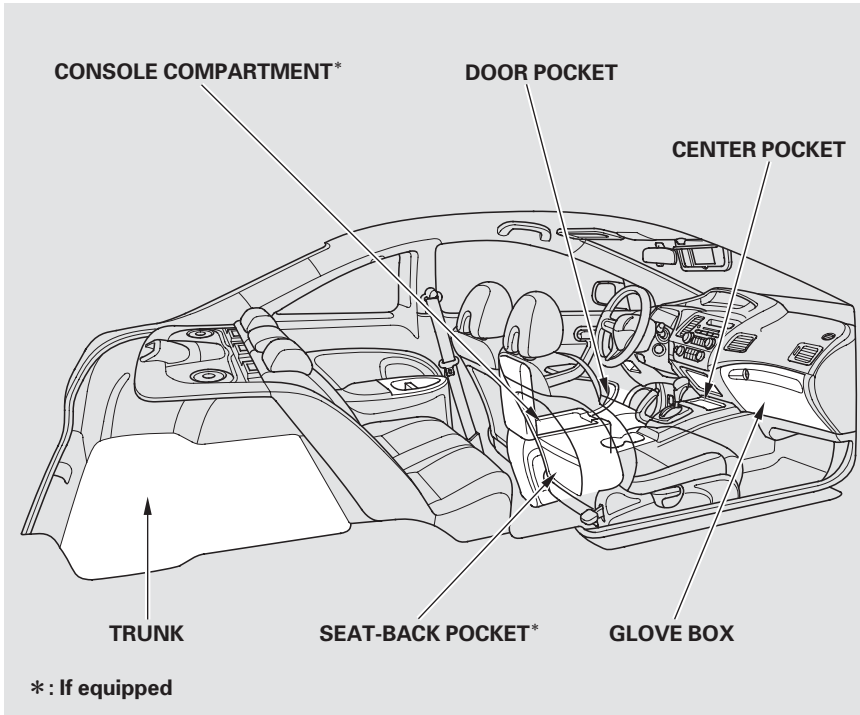

Your vehicle has several convenient storage areas:

- Glove box
- Door pockets
- Seat-back pocket*
- Console compartment*
- Center pocket
- Trunk, including the rear seats when folded down

However, carrying too much cargo, or improperly storing it, can affect your vehicle's handling, stability, stopping distance, and tires, and make it unsafe. Before carrying any type of cargo, be sure to read the following pages.

Carrying Cargo

Load Limits

The maximum load for your vehicle is 850 lbs (385 kg) for U.S. models and 395 kg for Canadian models.

See Tire And Loading Information label attached to the driver's doorjamb.

Label Example

TIRE AND LOADING INFORMATION			
SEATING CAPACITY		TOTAL 5	FRONT 2 REAR 3
The combined weight of occupants and cargo should never exceed 385kg or 850lbs.			
TIRE	SIZE	COLD TIRE PRESSURE	SEE OWNER'S MANUAL FOR ADDITIONAL INFORMATION
FRONT	XXXX/XXXXX XXX	XXXKPA.XXPSI	
REAR	XXXX/XXXXX XXX	XXXKPA.XXPSI	
SPARE	XXXX/XXXXX XXX	XXXKPA.XXPSI	

This figure includes the total weight of all occupants, cargo, and accessories, and the tongue load if you are towing a trailer.



⚠ WARNING

Overloading or improper loading can affect handling and stability and cause a crash in which you can be hurt or killed.

Follow all load limits and other loading guidelines in this manual.

Steps for Determining Correct Load Limit –

- (1) Locate the statement “The combined weight of occupants and cargo should never exceed XXX kg or XXX lbs.” on your vehicle’s placard.
- (2) Determine the combined weight of the driver and passengers that will be riding in your vehicle.
- (3) Subtract the combined weight of the driver and passengers from XXX kg or XXX lbs.
- (4) The resulting figure equals the available amount of cargo and luggage load capacity. For example, if the “XXX” amount equals 1,400 lbs. and there will be five 150 lb. passengers in your vehicle, the amount of available cargo and luggage load capacity is 650 lbs.
 $(1,400 - 750 (5 \times 150) = 650 \text{ lbs.})$
- (5) Determine the combined weight of luggage and cargo being loaded on the vehicle. That weight may not safely exceed the available cargo and luggage load capacity calculated in Step 4.
- (6) If your vehicle will be towing a trailer, load from your trailer will be transferred to your vehicle. Consult this manual to determine how this reduces the available cargo and luggage load capacity of your vehicle.

<p>Example 1</p>	 <p>Max Load 850 lbs (395 kg)*</p> <p>Passenger Weight 150 lbs x 2 = 300 lbs (68 kg x 2 = 136 kg)</p> <p>Cargo Weight 550 lbs (259 kg)*</p>
<p>Example 2</p>	 <p>Max Load 850 lbs (395 kg)*</p> <p>Passenger Weight 150 lbs x 4 = 600 lbs (68 kg x 4 = 272 kg)</p> <p>Cargo Weight 250 lbs (123 kg)*</p>
<p>Example 3</p>	 <p>Max Load 850 lbs (395 kg)*</p> <p>Passenger Weight 150 lbs x 5 = 750 lbs (68 kg x 5 = 340 kg)</p> <p>Cargo Weight 100 lbs (55 kg)*</p>

* : Canadian models

In addition, the total weight of the vehicle, all occupants, accessories, cargo, and trailer tongue load must not exceed the Gross Vehicle Weight Rating (GVWR) or the Gross Axle Weight Rating (GAWR). Both are on a label on the driver's doorjamb.

Carrying Cargo

Carrying Items in the Passenger Compartment

- Store or secure all items that could be thrown around and hurt someone during a crash.
- Do not put any items on top of the rear shelf. They can block your view and be thrown around the vehicle during a crash.
- Be sure items placed on the floor behind the front seats cannot roll under the seats and interfere with the driver's ability to operate the pedals, the operation of the seats, or the operation of the sensors under the seats.
- Keep all cargo below the bottom of the windows. If it is higher, it could interfere with the proper operation of the side curtain airbags.

- Keep the glove box closed while driving. If it is open, a passenger could injure their knees during a crash or sudden stop.

Carrying Cargo in the Trunk

- Distribute cargo evenly on the floor of the trunk, placing the heaviest items on the bottom and as far forward as possible.
- If you fold down the back seat, tie down items that could be thrown about the vehicle during a crash or sudden stop.
- If you carry large items that prevent you from closing the trunk lid, exhaust gas can enter the passenger area. To avoid the possibility of **carbon monoxide poisoning**, follow the instructions on page 52 .

Cargo Net

Optional

The cargo net can be used to help hold down items stored in the trunk.

This section gives you tips on starting the engine under various conditions, and how to operate the manual and automatic transmissions. It also includes important information on parking your vehicle, the braking system, the vehicle stability assist (VSA®) system, and the tire pressure monitoring system (TPMS).

- Driving Guidelines 268
- Preparing to Drive 269
- Starting the Engine..... 270
- Manual Transmission..... 271
- Automatic Transmission..... 274
- Parking 278
- Braking System..... 279
- Anti-lock Brakes (ABS) 280
- Vehicle Stability Assist (VSA®),
aka Electronic Stability
Control (ESC), System 282
- Tire Pressure Monitoring System
(TPMS) 284
- Towing a Trailer 287

Driving Guidelines

Si model

Your vehicle is designed to give you optimum handling and performance on well-maintained roads. As part of this design, your vehicle has a minimum of ground clearance and very low-profile tires.

- Use caution if you ever drive your vehicle on very rough or rutted roads. You could damage the suspension and underbody by bottoming out. Going too fast over parking lot “speed bumps” can also cause damage.

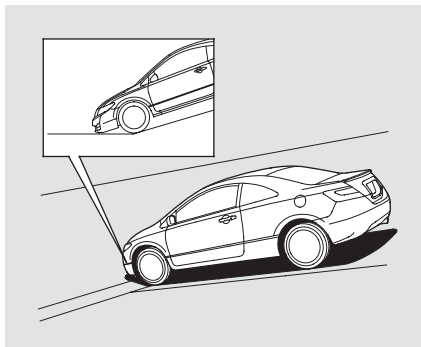

- Curbs and steep inclines could damage the front and rear bumpers. Low curbs that do not affect the average vehicle may be high enough to hit the bumper on your vehicle. The front or rear bumper may scrape when trying to drive onto an incline, such as a steep driveway or trailer ramps.

- Because of the low-profile tires fitted to your vehicle, the alloy wheels are closer to the ground. Driving over a pothole or road debris at too high a speed can seriously damage a wheel. Slow down under these conditions.

You should do the following checks and adjustments before you drive your vehicle.

1. Make sure all windows, mirrors, and outside lights are clean and unobstructed. Remove frost, snow, or ice.
2. Check that the hood is fully closed.
3. Check that the trunk is fully closed.
4. Visually check the tires. If a tire looks low, use a gauge to check its pressure.
5. Check that any items you may be carrying are stored properly or fastened down securely.
6. Check the seat adjustment (see page 95).
7. Check the adjustment of the inside and outside mirrors (see page 108).
8. Check the steering wheel adjustment (see page 78).
9. Make sure the doors are securely closed and locked.
10. Fasten your seat belt. Check that your passengers have fastened their seat belts (see page 14).
11. When you start the engine, check the gauges and indicators in the instrument panel (see page 57).

Starting the Engine

1. Apply the parking brake.
2. In cold weather, turn off all electrical accessories to reduce the drain on the battery.
3. *Manual transmission:*
Press the clutch pedal down all the way. The START (III) position does not function unless the clutch pedal is pressed.

Automatic transmission:

Make sure the shift lever is in Park. Press on the brake pedal.

4. Without touching the accelerator pedal, turn the ignition key to the START (III) position. Do not hold the key in the START (III) position for more than 15 seconds at a time. If the engine does not start right away, pause for at least 10 seconds before trying again.

NOTICE

The immobilizer system protects your vehicle from theft. If an improperly coded key (or other device) is used, the engine's fuel system is disabled. For more information, see page 80 .

NOTICE

The engine is harder to start in cold weather. Also, the thinner air found at altitudes above 8,000 feet (2,400 meters) adds to this problem.

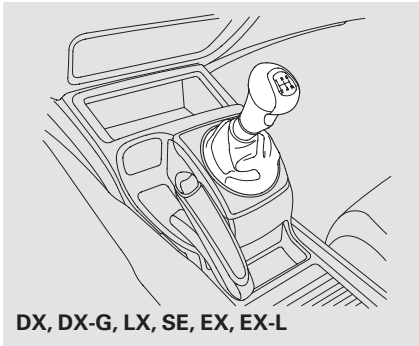

The manual transmission is synchronized in all forward gears for smooth operation. It has a lockout so you cannot shift directly from fifth to reverse.

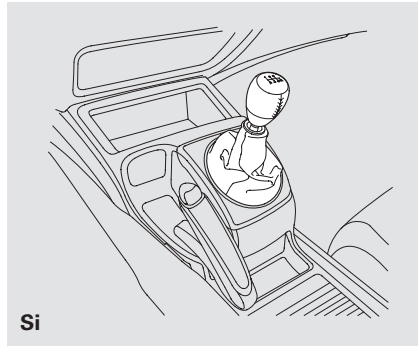

On vehicles with 6-speed manual transmission, the lockout system prevents you from shifting directly from any forward gear to reverse while the vehicle is moving at a certain speed (see page 273).

When shifting up or down, make sure you push the clutch pedal down all the way, shift to the next gear, and let the pedal up gradually. When you are not shifting, do not rest your foot on the clutch pedal. This can

cause your clutch to wear out faster.

Come to a full stop before you shift into reverse. You can damage the transmission by trying to shift into reverse with the vehicle moving. Push down the clutch pedal, and pause for a few seconds before shifting into reverse, or shift into one of the forward gears for a moment. This stops the gears so they won't "grind."

NOTE: *The engine can be damaged if you inadvertently downshift into the wrong gear (for example, going from third gear at high rpms to second gear instead of upshifting to fourth gear; the engine speed limiter will not work in this situation).*

CONTINUED

Manual Transmission

When slowing down, you can get extra braking from the engine by shifting to a lower gear. This extra braking can help you maintain a safe speed and prevent your brakes from overheating while going down a steep hill. Before downshifting, make sure the engine speed will not go into the tachometer's red zone in the lower gear.

⚠ WARNING

Rapid slowing or speeding up can cause loss of control on slippery surfaces. If you crash, you can be injured.

Use extra care when driving on slippery surfaces.

On Si model

Your vehicle is equipped with an aluminum shift lever. If you leave the vehicle parked outside for a long

time on a hot day, be careful before moving the shift lever. Because of the heat, the shift lever may be extremely hot. If the outside temperature is low, the shift lever feels cold.

Recommended Shift Points

Drive in the highest gear that lets the engine run and accelerate smoothly. This will give you good fuel economy and effective emissions control. The following shift points are recommended:

On models with 5-speed manual transmission

Shift up	Normal acceleration
1st to 2nd	15 mph (24 km/h)
2nd to 3rd	27 mph (44 km/h)
3rd to 4th	39 mph (63 km/h)
4th to 5th	53 mph (85 km/h)

On models with 6-speed manual transmission

Shift up	Normal acceleration
1st to 2nd	17 mph (27 km/h)
2nd to 3rd	29 mph (46 km/h)
3rd to 4th	37 mph (60 km/h)
4th to 5th	43 mph (69 km/h)
5th to 6th	49 mph (79 km/h)

Engine Speed Limiter

If you exceed the maximum speed for the gear you are in, the engine speed will enter into the tachometer's red zone. If this occurs, you may feel the engine cut in and out. This is caused by a limiter in the engine's computer controls. The engine will run normally when you reduce the rpm below the red zone.

Before downshifting, make sure the engine will not go into the tachometer's red zone.

On Si model

Your vehicle has a rev limit indicator to show you when the engine speed is near the tachometer's red zone (see page 63).

Reverse Lockout

6-speed manual transmission

The manual transmission has a lockout so you cannot accidentally shift from any forward gear to reverse while the vehicle is moving at a certain speed. If you cannot shift to reverse when the vehicle is stopped, do the following:

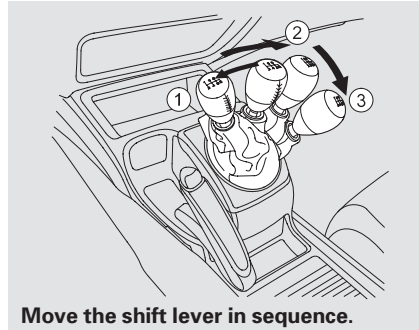

Move the shift lever in sequence.

1. With the clutch pedal pressed, move the shift lever to the first/second gear side of the neutral gate, then shift to reverse.

2. If you are still unable to shift to reverse, apply the parking brake, and turn the ignition key to the ACCESSORY (I) or LOCK (0) position.
3. Press the clutch pedal, and shift to reverse.
4. With the clutch pedal still pressed, start the engine.

If you need to use this procedure to shift to reverse, your vehicle may be developing a problem. Have the vehicle checked by your dealer.

Automatic Transmission

Shift Lever Position Indicators

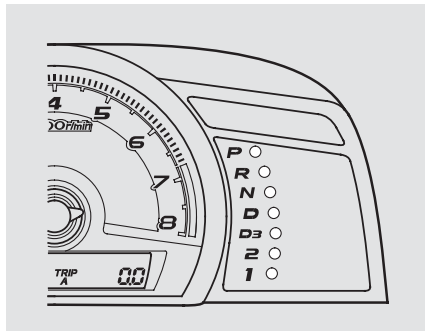

These indicators on the instrument panel show which position the shift lever is in.

The “D” indicator comes on for a few seconds when you turn the ignition switch to the ON (II) position. If it flashes while driving (in any shift position), it indicates a possible problem in the transmission.

If the malfunction indicator lamp comes on along with the “D” indicator, there is a problem with the automatic transmission control system. Avoid rapid acceleration, and have the transmission checked by your dealer as soon as possible.

Shifting

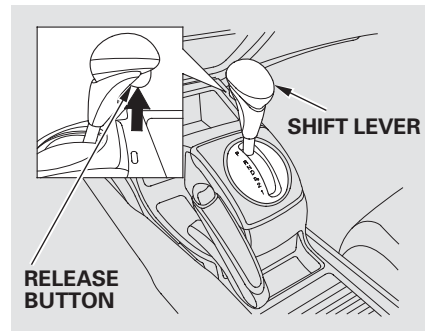

To shift from Park to any position, press firmly on the brake pedal, and press the release button on the front of the shift lever, then move the lever. You cannot shift out of Park when the ignition switch is in the LOCK (0) or ACCESSORY (I) position.

To shift from:	Do this:
P to R	Press the brake pedal, and press the shift lever release button.
R to P N to R D ₃ to 2 2 to 1	Press the shift lever release button.
1 to 2 2 to D ₃ D ₃ to D D to N D to D ₃ N to D R to N	Move the shift lever.

Park (P) – This position mechanically locks the transmission. Use Park whenever you are turning off or starting the engine. To shift out of Park, you must press on the brake pedal and have your foot off the accelerator pedal. Press the release button on the front of the shift lever to move it.

If you have done all of the above and still cannot move the lever out of Park, see **Shift Lock Release** on page 277 .

To avoid transmission damage, come to a complete stop before shifting into Park. You must also press the release button to shift into Park. The shift lever must be in Park before you can remove the key from the ignition switch.

Reverse (R) – Press the brake pedal and the release button on the front of the shift lever to shift from Park to reverse. To shift from reverse to neutral, come to a complete stop, and then shift. Press the release button before shifting into reverse from neutral.

Neutral (N) – Use neutral if you need to restart a stalled engine, or if it is necessary to stop briefly with the engine idling. Shift to the Park position if you need to leave your vehicle for any reason. Press on the brake pedal when you are moving the shift lever from neutral to another gear.

Drive (D) – Use this position for your normal driving. The transmission automatically selects a suitable gear (1 through 5) for your speed and acceleration. You may notice the transmission shifting up at higher engine speeds when the engine is cold. This helps the engine warm up faster.

CONTINUED

Automatic Transmission

Drive (D3) — This position is similar to D, except only the first three gears are selected. Use D3 to provide engine braking when going down a steep hill. D3 can also keep the transmission from cycling between third and fourth gears in stop-and-go driving.

Second (2) — To shift to second, press the release button on the front of the shift lever. This position locks the transmission in second gear. It does not downshift to first gear when you come to a stop.

Use second gear:

- For more power when climbing.
- To increase engine braking when going down steep hills.
- For starting out on a slippery surface or in deep snow.
- To help reduce wheel spin.

First (1) — To shift from second to first, press the release button on the front of the shift lever. This position locks the transmission in first gear. By upshifting and downshifting through 1, 2, D3, and D, you can operate the transmission much like a manual transmission without a clutch pedal.

Engine Speed Limiter

If you exceed the maximum speed for the gear you are in, the engine speed will enter into the tachometer's red zone. If this occurs, you may feel the engine cut in and out. This is caused by a limiter in the engine's computer controls. The engine will run normally when you reduce the rpm below the red zone.

Shift Lock Release

Do this if pushing on the brake pedal and pressing the release button does not let you shift the transmission out of Park:

1. Set the parking brake.
2. Remove the key from the ignition switch.

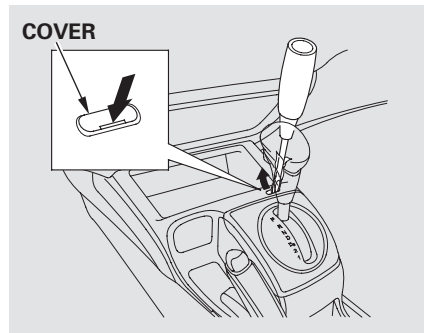

3. Put a cloth on the edge of the shift lock release slot to prevent scratches. Using a small flat-tip

screwdriver or metal fingernail file, carefully pry on the edge of the cover to remove it.

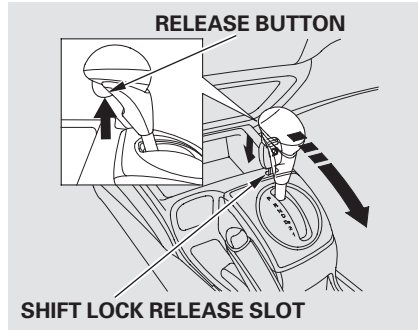

4. Insert the key in the shift lock release slot.
5. Push down on the key while you press the release button on the front of the shift lever and move the shift lever out of Park to neutral.

6. Remove the key from the shift lock release slot, then install the cover. Make sure the notch on the cover is on the rear. Insert the key into the ignition switch, press the brake pedal, and restart the engine.

If you need to use the shift lock release, it means your vehicle is developing a problem. Have it checked by your dealer.

Parking

Always use the parking brake when you park your vehicle. Make sure the parking brake is set firmly, or your vehicle may roll if it is parked on an incline.

If your vehicle has an automatic transmission, set the parking brake before you put the transmission in Park. This keeps the vehicle from moving and putting pressure on the parking mechanism in the transmission.

Parking Tips

- Make sure the moonroof (if equipped) and the windows are closed.
- Turn off the lights.
- Place any packages, valuables, etc., in the trunk or take them with you.
- Lock the doors.

On vehicles with security system

Check the indicator on the instrument panel to verify that the security system is set.

- Never park over dry leaves, tall grass, or other flammable materials. The hot three way catalytic converter could cause these materials to catch on fire.

- If the vehicle is facing uphill, turn the front wheels away from the curb. If your vehicle has a manual transmission, put it in first gear.
- If the vehicle is facing downhill, turn the front wheels toward the curb. If your vehicle has a manual transmission, put it in reverse gear.
- Make sure the parking brake is fully released before driving away. Driving with the parking brake partially set can overheat or damage the rear brakes.

NOTICE

Never install a sunshade between the upper and lower meters on the instrument panel. If you do, you could cause heat damage to the upper meter on a very hot day.

Your vehicle is equipped with front disc brakes. The brakes on the rear wheels may be disc or drum, depending on the model. A power assist helps reduce the effort needed on the brake pedal. The anti-lock brake system (ABS) helps you retain steering control when braking very hard.

On vehicles with vehicle stability assist (VSA) system, the emergency brake assist system increases the stopping force when you depress the brake pedal hard in an emergency situation.

Resting your foot on the pedal keeps the brakes applied lightly, builds up heat, reduces their effectiveness and reduces brake pad life. In addition, fuel economy can be reduced. It also keeps your brake lights on all the time, confusing drivers behind you.

Constant application of the brakes when going down a long hill builds up heat and reduces their effectiveness. Use the engine to assist the brakes by taking your foot off the accelerator and downshifting to a lower gear.

Check the brakes after driving through deep water. Apply the brakes moderately to see if they feel normal. If not, apply them gently and frequently until they do. Be extra cautious in your driving.

Braking System Design

The hydraulic system that operates the brakes has two separate circuits. Each circuit works diagonally across the vehicle (the left-front brake is connected with the right-rear brake, etc.). If one circuit should develop a problem, you will still have braking at two wheels.

Brake Pad Wear Indicators

If the brake pads need replacing, you will hear a distinctive, metallic screeching sound when you apply the brake pedal. If you do not have the brake pads replaced, they will screech all the time. It is normal for the brakes to occasionally squeal or squeak when you apply them.

Anti-lock Brakes (ABS)

The anti-lock brake system (ABS) helps prevent the wheels from locking up, and helps you retain steering control by pumping the brakes rapidly, much faster than a person can do it.

The electronic brake distribution (EBD) system, which is part of the ABS, also balances the front-to-rear braking distribution according to vehicle loading.

You should never pump the brake pedal. Let the ABS work for you by always keeping firm, steady pressure on the brake pedal. This is sometimes referred to as “stomp and steer.”

You will feel a pulsation in the brake pedal when the ABS activates, and you may hear some noise. This is normal: it is the ABS rapidly pumping the brakes. On dry pavement, you will need to press on the brake pedal very hard before the ABS activates. However, you may feel the ABS activate immediately if you are trying to stop on snow or ice.



ABS Indicator

If this indicator comes on, the anti-lock function of the braking system has shut down. The brakes still work like a conventional system, but without anti-lock. You should have your dealer inspect your vehicle as soon as possible.

If the indicator comes on while driving, test the brakes as instructed on page 351 .

If the ABS indicator and the brake system indicator come on together, and the parking brake is fully released, the EBD system may also be shut down.

Test your brakes as instructed on page 351. If the brakes feel normal, drive slowly and have your vehicle repaired by your dealer as soon as possible. Avoid sudden hard braking which could cause the rear wheels to lock up and possibly lead to a loss of control.

Important Safety Reminders
ABS does not reduce the time or distance it takes to stop the vehicle. It only helps with the steering control during braking.

ABS will not prevent a skid that results from changing direction abruptly, such as trying to take a corner too fast or making a sudden lane change. Always drive at a safe speed for the road and weather conditions.

ABS cannot prevent a loss of stability. Always steer moderately when you are braking hard. Severe or sharp steering wheel movement can still cause your vehicle to veer into oncoming traffic or off the road.

A vehicle with ABS may require a longer distance to stop on loose or uneven surfaces, such as gravel or snow, than a vehicle without anti-lock.

Vehicle Stability Assist (VSA®), aka Electronic Stability Control (ESC), System

EX-L and Si models

The vehicle stability assist (VSA) system helps to stabilize the vehicle during cornering if the vehicle turns more or less than desired. It also assists you in maintaining traction while accelerating on loose or slippery road surfaces. It does this by regulating the engine's output and by selectively applying the brakes.

When VSA activates, you may notice that the engine does not respond to the accelerator in the same way it does at other times. There may also be some noise from the VSA hydraulic system. You will also see the VSA activation indicator blink.

The VSA system cannot enhance the vehicle's driving stability in all situations and does not control your vehicle's entire braking system. It is still your responsibility to drive and corner at reasonable speeds and to leave a sufficient margin of safety.



VSA Activation Indicator

When VSA activates, you will see the VSA Activation indicator blinks.



Vehicle Stability Assist (VSA) System Indicator

If this indicator comes on while driving, pull to the side of the road when it is safe, and turn off the engine. Reset the system by restarting the engine. If the VSA system indicator stays on or comes back on while driving, have the VSA system inspected by your dealer.

NOTE: The main function of the VSA system is generally known as Electronic Stability Control (ESC). The system also includes a traction control function.

Without VSA, your vehicle will have normal braking and cornering ability, but it will not have VSA traction and stability enhancement.

U.S. models

If the low tire pressure indicator or TPMS indicator comes on, the VSA system automatically turns on even if the VSA system is turned off by pressing the VSA OFF switch (see page 283). If this happens, you cannot turn the VSA system off by pressing the VSA OFF switch again.

Vehicle Stability Assist (VSA®), aka Electronic Stability Control (ESC), System

VSA OFF Switch

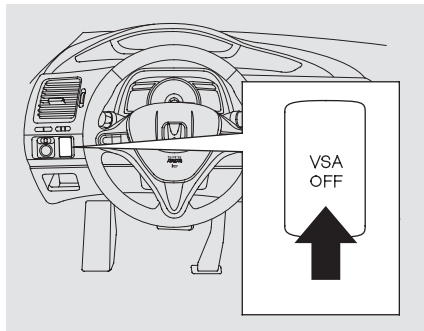

This switch is under the driver's side vent. To turn the VSA system on and off, press and hold it until you hear a beep.

When VSA is off, the VSA activation indicator comes on as a reminder. Press and hold the switch again. It turns the system back on.

VSA is turned on every time you start the engine, even if you turned it off the last time you drove the vehicle.

In certain unusual conditions when your vehicle gets stuck in shallow mud or fresh snow, it may be easier to free it with the VSA temporarily switched off. When the VSA system is off, the traction control system is also off. You should only attempt to free your vehicle with the VSA off if you are not able to free it when the VSA is on.

Immediately after freeing your vehicle, be sure to switch the VSA on again. We do not recommend driving your vehicle with the VSA and traction control systems switched off.

VSA and Tire Sizes

Driving with varying tire or wheel sizes may cause the VSA to malfunction. When replacing tires, make sure they are of the same size and type as your original tires (see page 330).

If you install winter tires, make sure they are the same size as those that were originally supplied with your vehicle. Exercise the same caution during winter driving as you would if your vehicle was not equipped with VSA.

Tire Pressure Monitoring System (TPMS)

U.S. models only

Your vehicle is equipped with a tire pressure monitoring system (TPMS) that turns on every time you start the engine and monitors the pressure in your tires while driving.

Each tire has its own pressure sensor (not including the spare tire). If the air pressure of a tire becomes significantly low while driving, the sensor in that tire immediately sends a signal that causes the low tire pressure indicator to come on.



Low Tire Pressure Indicator

When the low tire pressure indicator is on, one or more of your tires is significantly underinflated. You should stop and check your tires as soon as possible, and inflate them to the proper pressure as indicated on the vehicle's tire information placard.

If you think you can safely drive a short distance to a service station, proceed slowly, and inflate the tire to the recommended pressure shown on the driver's doorjamb.

If the tire is flat, or if the tire pressure is too low to continue driving, replace the tire with the compact spare tire (see page 339).

If you cannot make the low tire pressure indicator go out after inflating the tires to the specified values, have your dealer check the system as soon as possible.

Driving on a significantly underinflated tire causes the tire to overheat and can lead to tire failure. Underinflation also reduces fuel efficiency and tire tread life, and may affect the vehicle's handling and stopping ability.

Because tire pressure varies by temperature and other conditions, the low tire pressure indicator may come on unexpectedly.

Tire Pressure Monitoring System (TPMS)

For example, if you check and fill your tires in a warm area, then drive in extremely cold weather, the tire pressure will be lower than measured and could be underinflated and cause the low tire pressure indicator to come on. Or, if you check and adjust your tire pressure in cooler conditions, and drive into extremely hot conditions, the tire may become overinflated. However, the low tire pressure indicator will not come on if the tires are overinflated.

Refer to page 323 for tire inflation guidelines.

Although your tire pressure is monitored, you must manually check the tire pressures monthly.

Each tire, including the spare, should be checked monthly when cold, and set to the recommended inflation pressure as specified on the tire

information label and in the owner's manual (see page 325).

TPMS Tire Pressure Monitoring System (TPMS) Indicator

This indicator comes on and stays on if there is a problem with the tire pressure monitoring system.

If this happens, the system will shut off and no longer monitor tire pressures. Have the system checked by your dealer as soon as possible.

On vehicles with VSA system

If the low tire pressure indicator or TPMS indicator comes on, the VSA system automatically turns on even if the VSA system is turned off by pressing the VSA OFF switch (see page 283). If this happens, you cannot turn the VSA system off by pressing the VSA OFF switch again.

When you restart the vehicle with the compact spare tire, the TPMS indicator may also come on and stay on after driving several miles (kilometers).

Tire Pressure Monitoring System (TPMS)

Changing a Tire with TPMS

If you have a flat tire, the low tire pressure indicator will come on. Replace the flat tire with the compact spare tire (see page 339).

Each wheel (except the compact spare tire wheel) is equipped with a tire pressure sensor. You must use TPMS specific wheels. It is recommended that you always have your tires serviced by your dealer or qualified technician.

After you replace the flat tire with the compact spare tire, the low tire pressure indicator stays on. This is normal; the system is not monitoring the spare tire pressure. Manually check the spare tire pressure to be sure it is correct. After several miles (kilometers) driving with the compact spare tire, the TPMS indicator comes on and the low tire pressure indicator goes off.

The low tire pressure indicator or the TPMS indicator will go off, after several miles (kilometers) driving, when you replace the spare tire with the specified regular tire equipped with the tire pressure monitor sensor.

Never use a puncture-repairing agent in a flat tire. If used, you will have to replace the tire pressure sensor. Have the flat tire repaired by your dealer as soon as possible.

As required by the FCC:

This device complies with Part 15 of the FCC rules. Operation is subject to the following two conditions: (1) This device may not cause harmful interference, and (2) this device must accept any interference received, including interference that may cause undesired operation.

Changes or modifications not expressly approved by the party responsible for compliance could void the user's authority to operate the equipment.

This device complies with Industry Canada Standard RSS-210. Operation is subject to the following two conditions: (1) this device may not cause interference, and (2) this device must accept any interference that may cause undesired operation of the device.

Your vehicle is not designed to tow a trailer. Attempting to do so can void your warranties.

Towing Your Vehicle

Your vehicle is not designed to be towed behind a motor home. If your vehicle needs to be towed in an emergency, see page 358 .

This section explains why it is important to keep your vehicle well maintained and how to follow basic maintenance safety precautions.

This section also includes instructions on how to read the Maintenance Minder messages on the information display, and instructions for simple maintenance tasks you may want to take care of yourself.

If you have the skills and tools to perform more complex maintenance tasks on your vehicle, you may want to purchase the service manual. See page 383 for information on how to obtain a copy, or see your dealer.

U.S. Vehicles:
Maintenance, replacement, or repair of emissions control devices and systems may be done by any automotive repair establishment or individual using parts that are “certified” to EPA standards.

Maintenance Safety	290
Maintenance Minder™	291
Fluid Locations.....	298
Adding Engine Oil.....	300
Recommended Engine Oil.....	300
Synthetic Oil.....	301
Engine Oil Additives	301
Changing the Engine Oil and Filter	302
Engine Coolant.....	304
Windshield Washers	307
Automatic Transmission Fluid.....	308
Manual Transmission Fluid	309
Brake and Clutch Fluid.....	310
Power Steering Fluid.....	311
Lights	312
Cleaning the Seat Belts.....	319
Floor Mats	320
Dust and Pollen Filter	321
Wiper Blades	321
Tires	323
Checking the Battery.....	333
Vehicle Storage.....	335
Interior Care.....	336

Maintenance Safety

All service items not detailed in this section should be performed by a certified technician or other qualified mechanic.

Important Safety Precautions

To eliminate potential hazards, read the instructions before you begin, and make sure you have the tools and skills required.

- Make sure your vehicle is parked on level ground, the parking brake is set, and the engine is off.
- To clean parts, use a commercially available degreaser or parts cleaner, not gasoline.
- To reduce the possibility of fire or explosion, keep cigarettes, sparks, and flames away from the battery and all fuel-related parts.
- Wear eye protection and protective clothing when working with the battery or compressed air.

⚠ WARNING

Improperly maintaining this vehicle, or failing to correct a problem before driving can cause a crash in which you can be seriously hurt or killed.

Always follow the inspection and maintenance recommendations and schedules in this owner's manual.

Potential Vehicle Hazards

- **Carbon Monoxide poison from engine exhaust.** Be sure there is adequate ventilation whenever you operate the engine.
- **Burns from hot parts.** Let the engine and exhaust system cool down before touching any parts.

- **Injury from moving parts.** Do not run the engine unless instructed to do so.

⚠ WARNING

Failure to properly follow maintenance instructions and precautions can cause you to be seriously hurt or killed.

Always follow the procedures and precautions in this owner's manual.

Some of the most important safety precautions are given here. However, we cannot warn you of every conceivable hazard that can arise in performing maintenance. Only you can decide whether or not you should perform a given task.

Your vehicle displays engine oil life and maintenance service items on the information display to show you when you should have your dealer perform engine oil replacement and indicated maintenance service.

Based on the engine operating conditions and accumulated engine revolutions, the onboard computer in your vehicle calculates the remaining engine oil life and displays it as a percentage.

Engine Oil Life Indicator

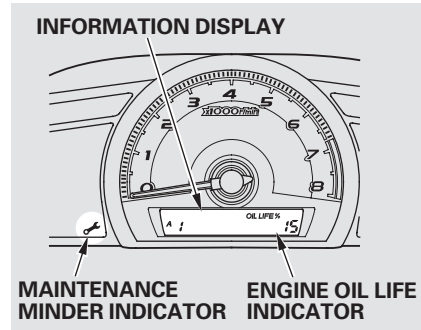

To see the current engine oil life, turn the ignition switch to the ON (II) position, then push and release the SEL/RESET button repeatedly until the engine oil life indicator appears (see page 67).

The remaining engine oil life is displayed on the information display according to this table:

Calculated Engine Oil Life (%)	Displayed Engine Oil Life (%)
100% – 91%	100%
90% – 81%	90%
80% – 71%	80%
70% – 61%	70%
60% – 51%	60%
50% – 41%	50%
40% – 31%	40%
30% – 21%	30%
20% – 16%	20%
15% – 11%*1	15%
10% – 6%*1	10%
15% – 6%*2	15%
5% – 1%	5%
0%	0%

- * 1 : DX and Canadian DX-G
- * 2 : LX, SE, EX, EX-L, and Si

CONTINUED

Maintenance Minder™

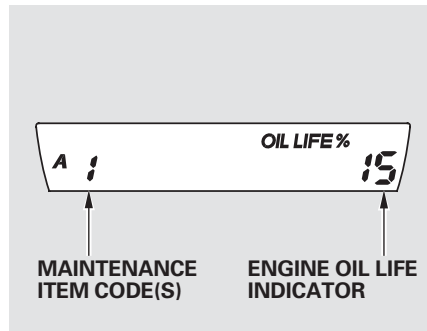

If the remaining engine oil life is 15 to 6 percent, you will see the engine oil life indicator every time you turn the ignition switch to the ON (II) position. The Maintenance Minder indicator will also come on, and the maintenance item code(s) for other scheduled maintenance items needing service will be displayed next to the engine oil life indicator.

The 15 and 10 percent oil life indicators remind you that your vehicle will soon be due for scheduled maintenance.

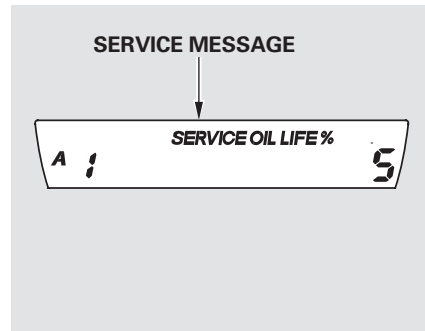

When the remaining engine oil life is 5 to 1 percent, you will see a “SERVICE” message along with the same maintenance item code(s), every time you turn the ignition switch to the ON (II) position.

The maintenance item code or codes indicate the main and sub items required at the time of the oil change (see page 297).

You can switch the display to the odometer, the trip meter, and the outside temperature indicator (if equipped) by pushing the SEL/RESET button on the dashboard repeatedly.

When the engine oil life is 15 to 1 percent, the Maintenance Minder indicator () comes on every time you turn the ignition switch to the ON (II) position, then it goes out if you switch the information display.

When you see this message, have the indicated maintenance performed by your dealer as soon as possible.

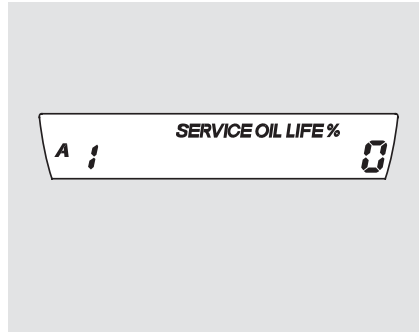

When the remaining engine oil life is 0 percent, the engine oil life indicator will blink. The display comes on every time you turn the ignition switch to the ON (II) position. The Maintenance Minder indicator () also comes on and remains on in the instrument panel. When you see this message, immediately have the indicated maintenance done by your dealer.

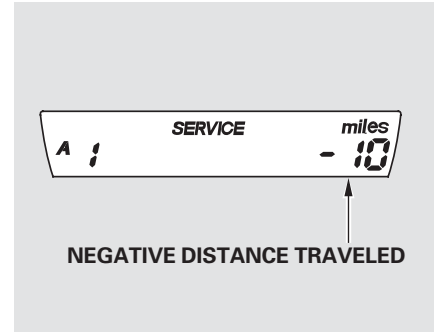

If you do not perform the indicated maintenance, negative distance traveled is displayed and begins to blink after the vehicle has been driven 10 miles (10 km) or more.

Negative distance traveled means your vehicle has passed the maintenance required point. Immediately have the indicated maintenance done by your dealer.

CONTINUED

Maintenance Minder™

You can change the information display from the engine oil life display to the odometer, the trip meter, or the outside temperature (if equipped) every time you press and release the SEL/RESET button.

When the engine oil life is 0 percent or negative distance traveled, the Maintenance Minder indicator () remains on even if you change the information display.

Immediately have the service performed, and make sure to reset the display as described as follows.

Maintenance Main Items and Sub Items

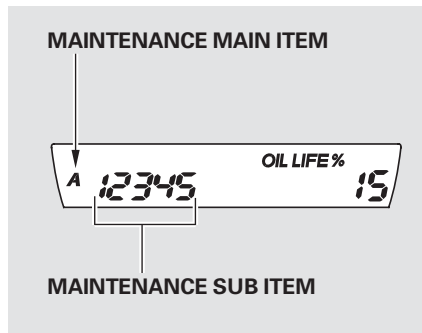

All maintenance items displayed on the information display are in code. For an explanation of these maintenance codes, see page 297 .

Resetting the Engine Oil Life Display

Your dealer will reset the display after completing the required maintenance service. You will see “OIL LIFE 100%” on the information display the next time you turn the ignition switch to the ON (II) position.

If maintenance service is done by someone other than your dealer, reset the Maintenance Minder as follows:

1. Turn the ignition switch to the ON (II) position.
2. Press the SEL/RESET button repeatedly until the engine oil life indicator is displayed.

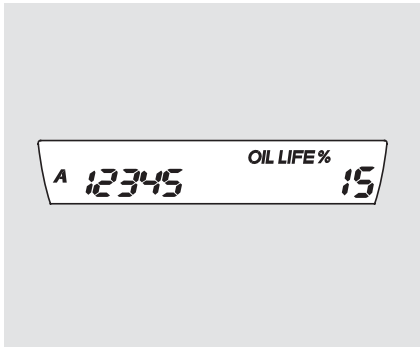

3. Press the SEL/RESET button for about 10 seconds. The engine oil life and the maintenance item code(s) will blink.

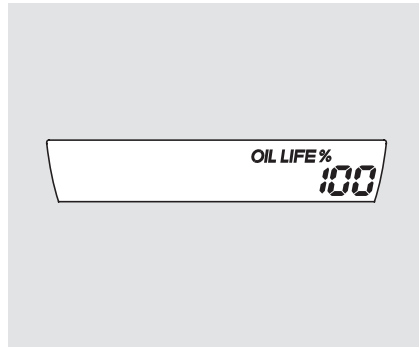

4. Press the SEL/RESET button for more than 5 seconds. The maintenance item code(s) will disappear, and the engine oil life will reset to "100."

Important Maintenance Precautions

If you have the required service done but do not reset the display, or reset the display without doing the service, the system will not show the correct maintenance intervals. This can lead to serious mechanical problems because you will no longer have an accurate record of when maintenance is needed.

Your authorized Honda dealer knows your vehicle best and can provide competent, efficient service.

CONTINUED

However, service at a dealer is not mandatory to keep your warranties in effect. Maintenance may be done by any qualified service facility or person who is skilled in this type of automotive service. Make sure to have the service facility or person reset the display as previously described. Keep all receipts as proof of completion, and have the person who does the work fill out your Honda Service History or Canadian Maintenance Log. Check your warranty booklet for more information.

We recommend using Honda parts and fluids whenever you have maintenance done. These are manufactured to the same high quality standards as the original components, so you can be confident of their performance and durability.

U.S. Vehicles:

According to state and federal regulations, failure to perform maintenance on the items marked with # will not void your emissions warranties. However, all maintenance services should be performed in accordance with the intervals indicated by the information display.

Owner's Maintenance Checks

You should check the following items at the specified intervals. If you are unsure of how to perform any check, turn to the appropriate page listed.

- Engine oil level — Check every time you fill the fuel tank. See page 255 .
- Engine coolant level — Check the radiator reserve tank every time you fill the fuel tank. See page 257 .

- Automatic transmission — Check the fluid level monthly. See page 308 .
- Brakes — Check the fluid level monthly. See page 310 .
- Tires — Check the tire pressure monthly. Examine the tread for wear and foreign objects. See page 323 .
- Lights — Check the operation of the headlights, parking lights, taillights, high-mount brake light, and license plate lights monthly. See page 312 .

Symbol	Maintenance Main Items
A	<ul style="list-style-type: none"> • Replace engine oil*
B	<ul style="list-style-type: none"> • Replace engine oil* and oil filter • Inspect front and rear brakes • Check parking brake adjustment • Visually inspect these items: <ul style="list-style-type: none"> • Tie rod ends, steering gear box, and boots • Suspension components • Driveshaft boots • Brake hoses and line (including ABS/VSA) • All fluid levels and condition of fluids • Exhaust system[#] • Fuel lines and connections[#]

Symbol	Maintenance Sub Items
1	<ul style="list-style-type: none"> • Rotate tires
2	<ul style="list-style-type: none"> • Replace air cleaner element If you drive in dusty conditions, replace every 15,000 miles (24,000 km). • Replace dust and pollen filter If you drive primarily in urban areas that have high concentrations of soot in the air from industry and from diesel-powered vehicles, replace every 15,000 miles (24,000 km). • Inspect drive belt
3	<ul style="list-style-type: none"> • Replace transmission fluid
4	<ul style="list-style-type: none"> • Replace spark plugs • Inspect valve clearance
5	<ul style="list-style-type: none"> • Replace engine coolant

* : If the message “SERVICE” does not appear more than 12 months after the display is reset, change the engine oil every year.

: See information on maintenance and emissions warranty in the center column on page 296.

NOTE: • Independent of the maintenance messages in the information display, replace the brake fluid every 3 years.
 • Inspect idle speed every 160,000 miles (256,000 km).
 • Adjust the valves during services A, B, 1, 2, or 3 only if they are noisy.

Fluid Locations

DX, LX, EX, EX-L, in the U.S., and DX-G, SE, EX, EX-L in the Canada

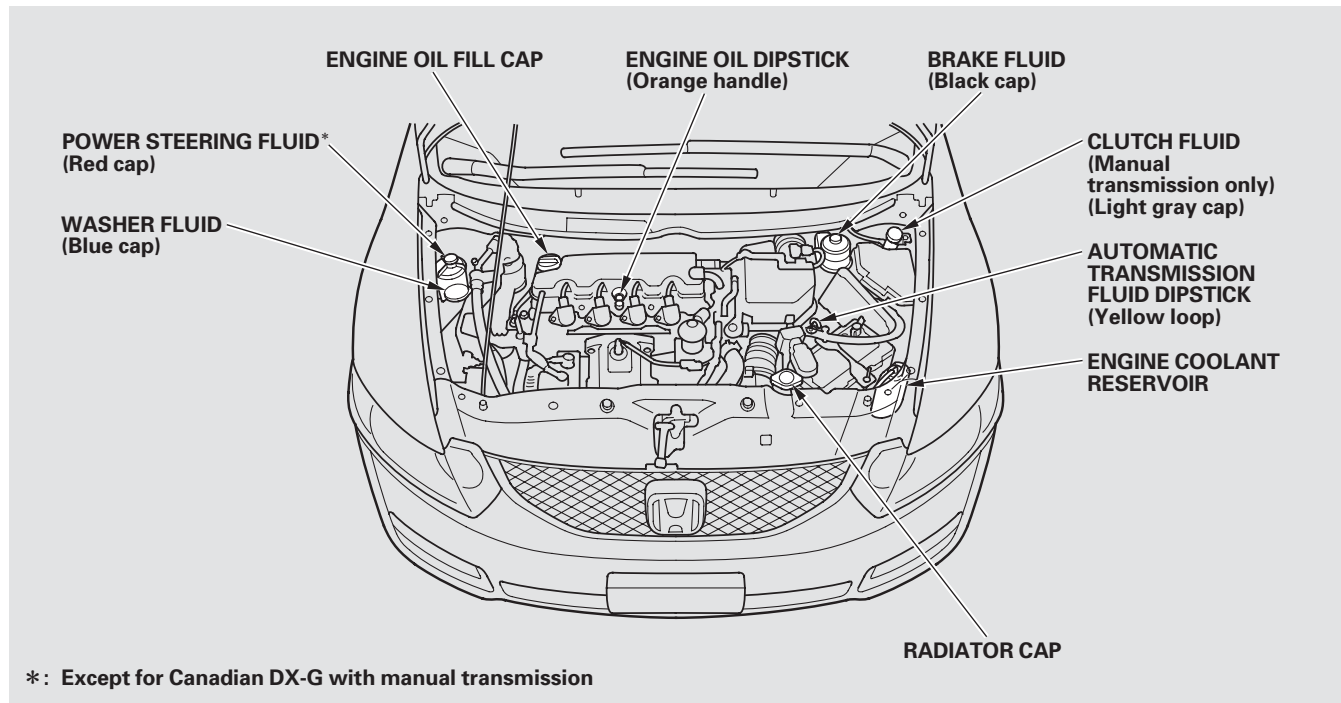

Si model

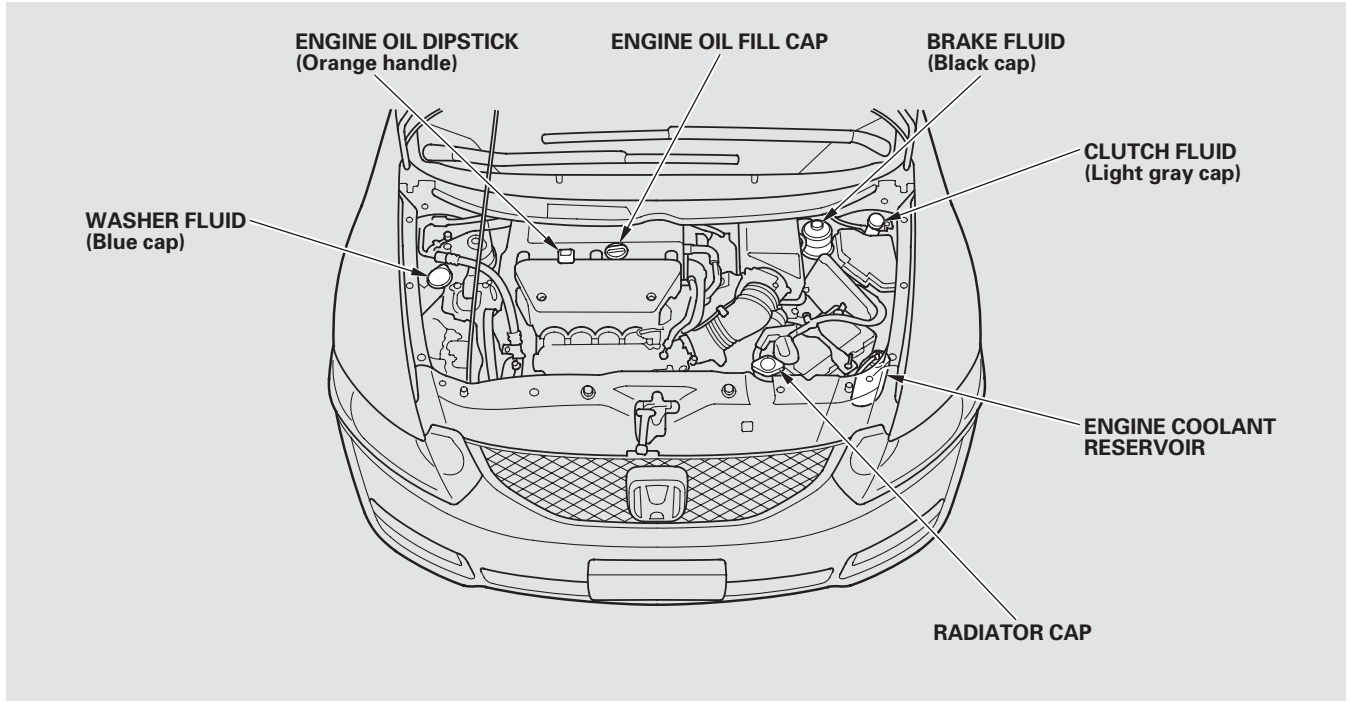

Adding Engine Oil

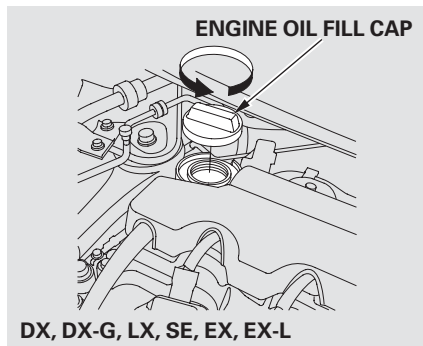

Unscrew and remove the engine oil fill cap on the valve cover. Pour the oil slowly and carefully so you do not spill any. Clean up any spills immediately. Spilled oil could damage components in the engine compartment.

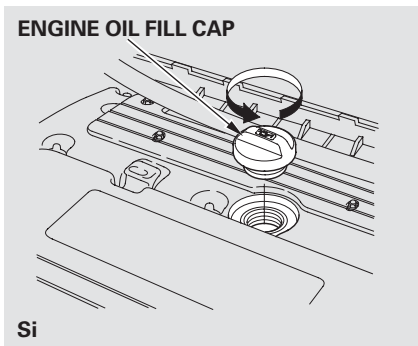

Reinstall the engine oil fill cap, and tighten it securely. Wait a few minutes, and recheck the oil level on the engine oil dipstick. Do not fill above the upper mark; you could damage the engine.

Recommended Engine Oil

Oil is a major contributor to your engine's performance and longevity. Always use a premium-grade detergent oil displaying the API Certification Seal. This seal indicates the oil is energy conserving, and that it meets the American Petroleum Institute's latest requirements. It is highly recommended that you use Honda Motor Oil in your vehicle for optimum engine protection.



API CERTIFICATION SEAL

Make sure the API Certification Seal says “For Gasoline Engines.”

The oil viscosity or weight is provided on the container’s label.

DX, DX-G, LX, SE, EX, and EX-L models:

Honda Motor Oil is the preferred 5W-20 lubricant for your vehicle. 5W-20 oil is formulated for year-round protection of your vehicle, to improve cold weather starting and fuel economy.

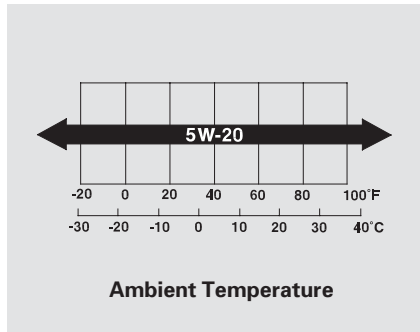

Si model:

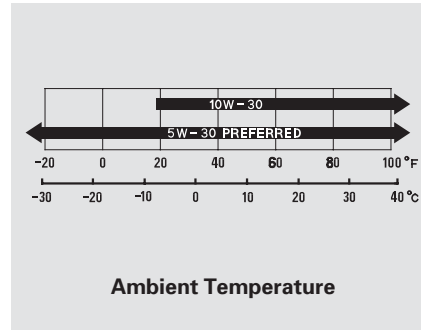

An oil with a viscosity of 5W-30 is preferred for improved fuel economy and year-round protection in your vehicle. You may use a 10W-30 oil if the temperature in your area never goes below 20°F (−7°C).

Synthetic Oil

You may use a synthetic motor oil if it meets the same requirements given for a conventional motor oil: it displays the API Certification Seal, and it is the proper weight. You must follow the oil and filter change intervals shown on the information display.

Engine Oil Additives

Your vehicle does not require any oil additives. Additives may adversely affect the engine or transmission performance and durability.

Changing the Engine Oil and Filter

Always change the oil and filter according to the maintenance messages shown on the information display. The oil and filter collect contaminants that can damage your engine if they are not removed regularly.

Changing the oil and filter requires special tools and access from underneath the vehicle. The vehicle should be raised on a service station-type hydraulic lift for this service. Unless you have the knowledge and proper equipment, you should have this maintenance done by a skilled technician.

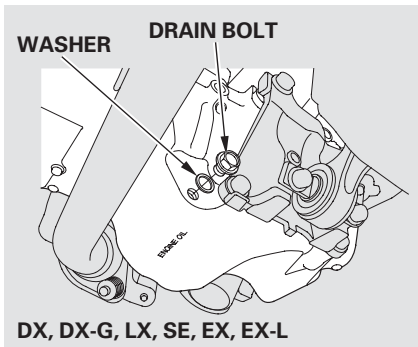

1. Run the engine until it reaches normal operating temperature, then shut it off.

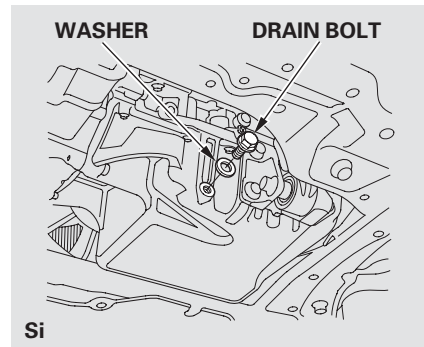

2. Open the hood, and remove the engine oil fill cap. Remove the oil drain bolt and washer from the bottom of the engine. Drain the oil into an appropriate container.

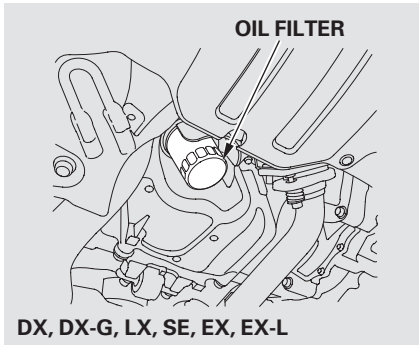

3. Remove the oil filter, and let the remaining oil drain. A special wrench (available from your dealer) is required.

Make sure the oil filter gasket is not stuck to the contacting surface of the engine. If it is, remove it before installing a new oil filter.

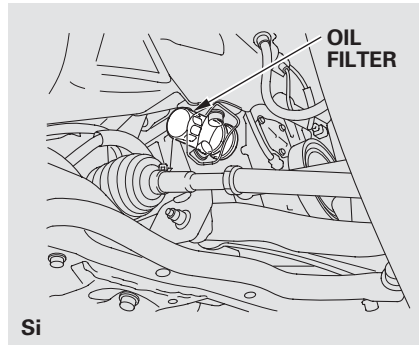

4. Install a new oil filter according to the instructions that come with it.

Make sure to clean off any dirt and dust on the contacting surface of a new oil filter.

5. Put a new washer on the drain bolt, then reinstall the drain bolt. Tighten the drain bolt to:
29 lbf·ft (39 N·m , 4.0 kgf·m)

6. Refill the engine with the recommended oil.
Engine oil change capacity (including filter):

DX, DX-G, LX, SE, EX, EX-L
3.9 US qt (3.7 ℓ)

Si
4.6 US qt (4.4 ℓ)

7. Reinstall the engine oil fill cap. Start the engine. The oil pressure indicator should go out within 5 seconds. If it does not, turn off the engine, and check your work.
8. Let the engine run for several minutes, then check the drain bolt and oil filter for leaks.

CONTINUED

Changing the Engine Oil and Filter, Engine Coolant

- Turn off the engine, let it sit for several minutes, then check the oil level on the dipstick. If necessary, add more oil.

NOTICE

Improper disposal of engine oil can be harmful to the environment. If you change your own oil, please dispose of the used oil properly. Put it in a sealed container and take it to a recycling center. Do not discard it in a trash bin or dump it on the ground.

Adding Engine Coolant

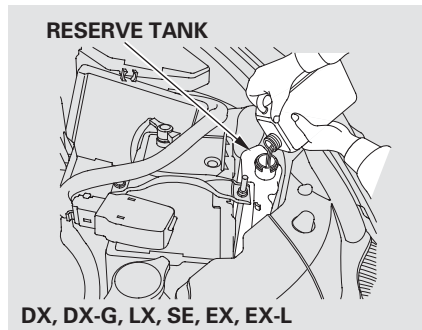

If the coolant level in the reserve tank is at or below the MIN line, add coolant to bring it up to the MAX line. Inspect the cooling system for leaks.

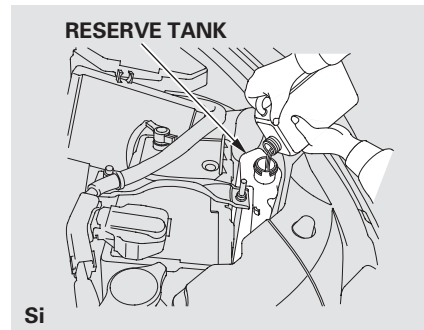

Always use Honda Long-life Anti-freeze/Coolant Type 2. This coolant is pre-mixed with 50 percent antifreeze and 50 percent distilled water. Never add straight antifreeze or plain water.

If Honda antifreeze/coolant is not available, you may use another major-brand non-silicate coolant as a temporary replacement. Make sure it is a high-quality coolant recommended for aluminum engines. Continued use of any non-Honda coolant can result in corrosion, causing the cooling system to malfunction or fail. Have the cooling system flushed and refilled with Honda antifreeze/coolant as soon as possible.

If the reserve tank is completely empty, you should also check the coolant level in the radiator.

⚠ WARNING

Removing the radiator cap while the engine is hot can cause the coolant to spray out, seriously scalding you.

Always let the engine and radiator cool down before removing the radiator cap.

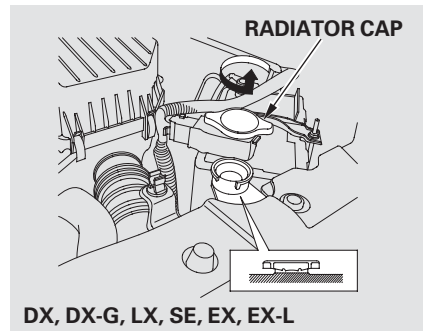

1. Make sure the engine and radiator are cool.
2. Relieve any pressure in the cooling system by turning the radiator cap counterclockwise, without pressing down.

CONTINUED

Engine Coolant

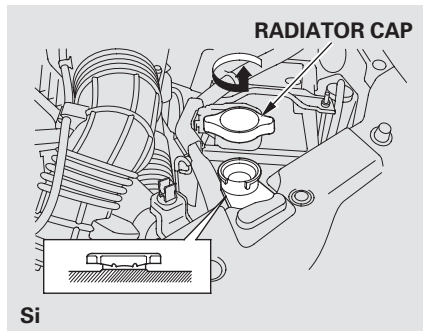

3. Remove the radiator cap by pushing down and turning counterclockwise.

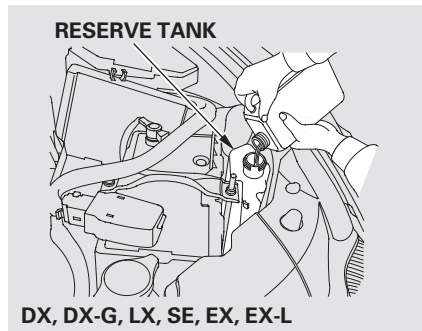

4. The coolant level should be up to the base of the filler neck. Add coolant if it is low.

Pour the coolant slowly and carefully so you do not spill any. Clean up any spill immediately; it could damage components in the engine compartment.

5. Put the radiator cap back on, and tighten it fully.

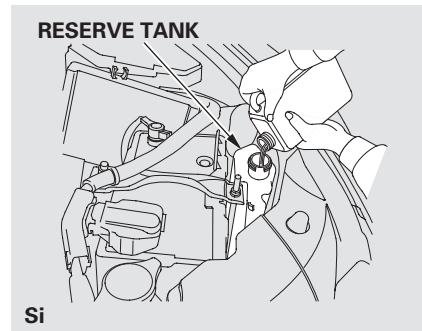

6. Pour coolant into the reserve tank. Fill it to halfway between the MAX and MIN marks. Put the cap back on the reserve tank.

Do not add any rust inhibitors or other additives to your vehicle's cooling system. They may not be compatible with the coolant or engine components.

Check the fluid level in the windshield washer reservoir at least monthly during normal use.

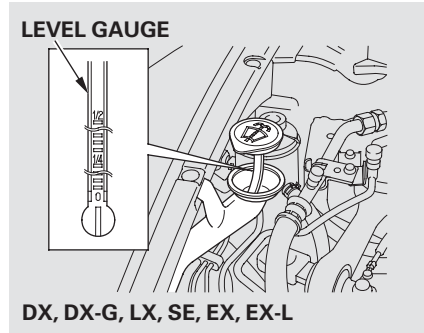

Check the fluid level by removing the cap and looking at the level gauge.

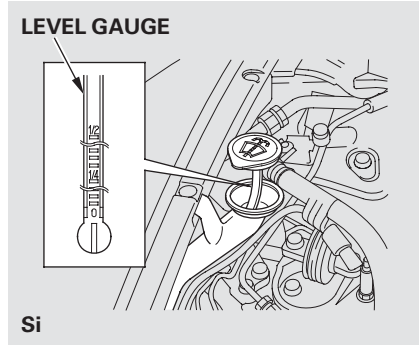

On Canadian models: The low washer level indicator comes on when the level is low (see page 65).

Fill the reservoir with a good-quality windshield washer fluid. This increases the cleaning capability and prevents freezing in cold weather.

When you refill the reservoir, clean the edges of the windshield wiper blades with windshield washer fluid on a clean cloth. This will help to condition the blade edges.

NOTICE

Do not use engine antifreeze or a vinegar/water solution in the windshield washer reservoir. Antifreeze can damage your vehicle's paint, while a vinegar/water solution can damage the windshield washer pump. Use only commercially-available windshield washer fluid.

Automatic Transmission Fluid

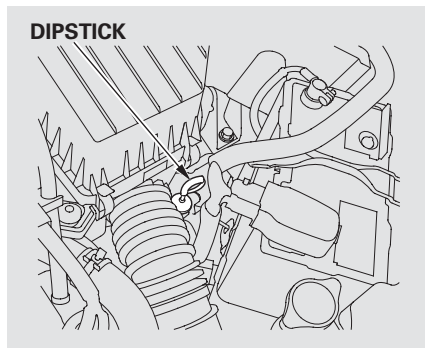

Check the fluid level with the engine at normal operating temperature.

1. Park the vehicle on level ground. Start the engine, let it run until the radiator fan comes on, then shut off the engine. For accurate results, wait about 60 seconds (but no longer than 90 seconds) before doing step 2.

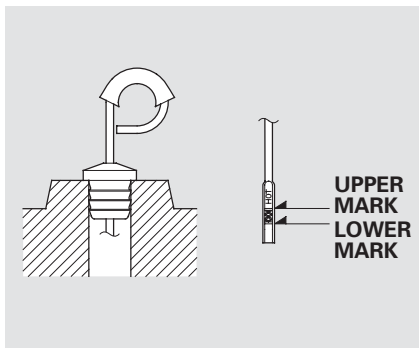

2. Remove the dipstick (yellow loop) from the transmission, and wipe it with a clean cloth.
3. Insert the dipstick all the way into the transmission securely as shown in the illustration.
4. Remove the dipstick, and check the fluid level. It should be between the upper and lower marks.

5. If the level is below the lower mark, add fluid into the dipstick hole to bring it to the level between the upper and lower marks.

Pour the fluid slowly and carefully so you do not spill any. Clean up any spill immediately; it could damage components in the engine compartment.

Always use Honda ATF DW-1 (automatic transmission fluid).

6. Insert the dipstick all the way back into the transmission securely as shown in the illustration.

Automatic Transmission Fluid, Manual Transmission Fluid

The transmission should be drained and refilled with new fluid according to the Maintenance Minder™ (see page 291).

If you are not sure how to add fluid, contact your dealer.

NOTICE

Use only Honda ATF DW-1 (automatic transmission fluid). Do not mix with other transmission fluids.

Using transmission fluid other than Honda ATF DW-1 may cause deterioration in transmission operation and durability, and could result in damage to the transmission.

Damage resulting from the use of transmission fluid other than Honda ATF DW-1 is not covered by the Honda new vehicle warranty.

Manual Transmission Fluid

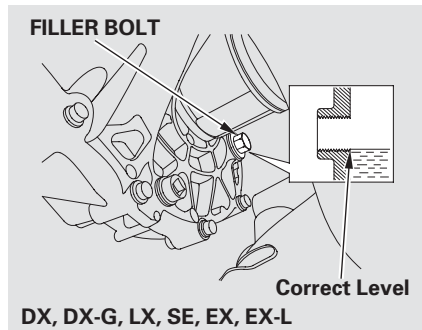

Check the fluid level with the transmission at normal operating temperature and the vehicle sitting on level ground. Remove the transmission filler bolt, and carefully feel inside the bolt hole with your finger. The fluid level should be up to the edge of the bolt hole. If it is not, add Honda Manual Transmission Fluid (MTF) until it starts to run out of the hole. Reinstall the filler bolt, and tighten it securely.

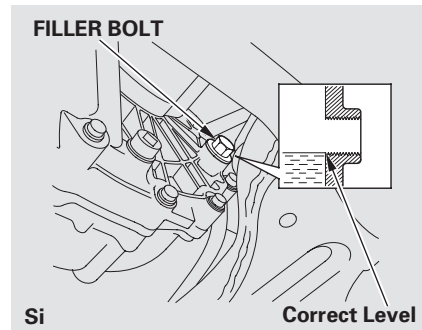

If Honda MTF is not available, you may use an SAE 10W-30 or 10W-40 viscosity motor oil with the API Certification Seal that says “FOR GASOLINE ENGINES” as a temporary replacement. However, motor oil does not contain the proper additives, and continued use can cause stiffer shifting. Replace as soon as it is convenient.

CONTINUED

Manual Transmission Fluid, Brake and Clutch Fluid

The transmission should be drained and refilled with new fluid according to the Maintenance Minder™ (see page 291).

If you are not sure how to check and add fluid, contact your dealer.

Brake and Clutch Fluid

Check the brake fluid level in the reservoirs monthly.

Independent of the Maintenance Minder information, replace the brake fluid every 3 years.

Always use Honda Heavy Duty Brake Fluid DOT 3. If it is not available, you should use only DOT 3 or DOT 4 fluid, from a sealed container, as a temporary replacement.

Using any non-Honda brake fluid can cause corrosion and decrease the life of the system. Have the brake system flushed and refilled with Honda Heavy Duty Brake Fluid DOT 3 as soon as possible.

Brake fluid marked DOT 5 is not compatible with your vehicle's braking system and can cause extensive damage.

Brake Fluid

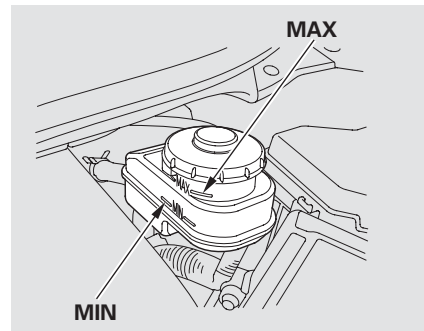

The fluid level should be between the MIN and MAX marks on the side of the reservoir. If the level is at or below the MIN mark, your brake system needs attention. Have the brake system inspected for leaks or worn brake pads.

Clutch Fluid

Manual Transmission only

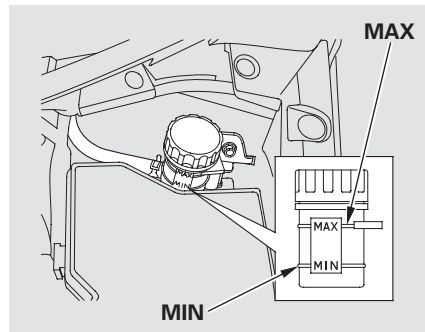

The fluid level should be between the MIN and MAX marks on the side of the reservoir. If it is not, add brake fluid to bring it up to that level. Use the same fluid specified for the brake system.

A low fluid level can indicate a leak in the clutch system. Have this system inspected as soon as possible.

Power Steering Fluid

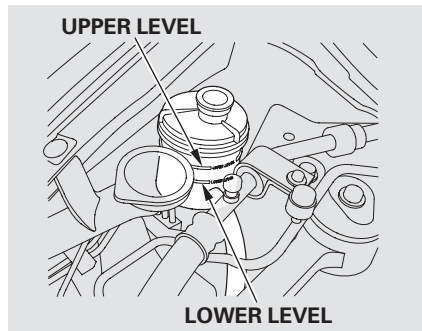

All models except Si and Canadian DX-G with manual transmission

Check the level on the side of the reservoir when the engine is cold. The fluid should be between the UPPER LEVEL and LOWER LEVEL. If not add power steering fluid to the UPPER LEVEL mark.

Pour the fluid slowly and carefully so you do not spill any. Clean up any spill immediately; it could damage components in the engine compartment.

Always use Honda Power Steering Fluid. You may use another power steering fluid as an emergency replacement, but have the power steering system flushed and refilled with Honda PSF as soon as possible.

A low power steering fluid level can indicate a leak in the system. Check the fluid level frequently, and have the system inspected as soon as possible.

NOTICE

Turning the steering wheel to full left or right lock and holding it there can damage the power steering pump.

Lights

Headlight Aiming

The headlights were properly aimed when your vehicle was new. If you regularly carry heavy items in the trunk, readjustment may be required. Adjustments should be done by your dealer or another qualified technician.

NOTICE

Halogen headlight bulbs get very hot when lit. Oil, perspiration, or a scratch on the glass can cause the bulb to overheat and shatter.

Replacing a Headlight Bulb

Your vehicle has halogen headlight bulbs. When replacing a bulb, handle it by its base, and protect the glass from contact with your skin or hard objects. If you touch the glass, clean it with denatured alcohol and a clean cloth.

High Beam Headlight

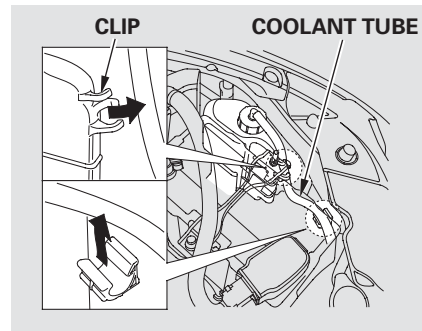

1. Open the hood.

To change a bulb on the driver's side, remove the coolant tube from the two clips, then remove the reserve tank from its holder by pulling it straight up.

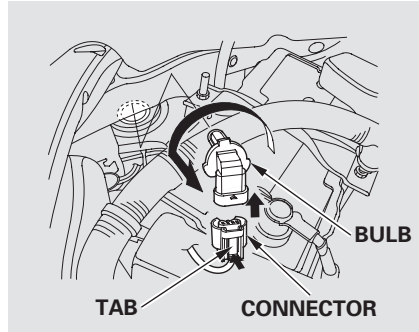
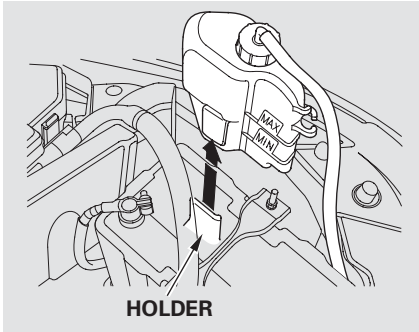

2. Remove the electrical connector from the bulb by pushing on the tab to unlock it, then slide the connector off the bulb.
3. Remove the bulb by turning it about one-quarter turn counterclockwise.

4. Insert the new bulb into the hole, and turn it one-quarter turn clockwise to lock it in place.
5. Push the electrical connector back onto the bulb. Make sure it is on all the way.
6. Turn on the headlights to test the new bulb.
7. (Driver's side)
Put the tube back in the clips and install the reserve tank back in place, making sure its bottom tab is in the holder.

CONTINUED

Lights

Low Beam Headlight

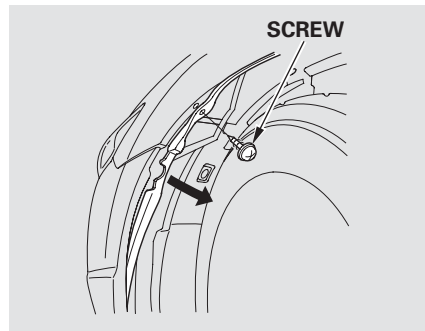

1. To change the driver's side bulb, start the engine, turn the steering wheel all the way to the right, and turn off the engine. To change the passenger's side bulb, turn the steering wheel to the left.

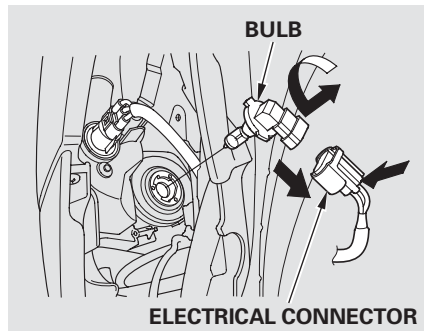

2. Use a Phillips-head screwdriver to remove the screw from the inner fender, and pull the inner fender cover back.
3. Remove the electrical connector from the bulb by pushing on the tab to unlock it, then slide the connector off the bulb.

4. Remove the bulb from the headlight assembly by turning it one-quarter turn counterclockwise.
5. Insert the new bulb into the hole, and turn it one-quarter turn clockwise to lock it in place.
6. Push the electrical connector back onto the bulb. Make sure it is on all the way.
7. Turn on the headlights to test the new bulb.
8. Reinstall the inner fender cover. Then reinstall the screw and tighten it securely.

Replacing the Front Side Marker/ Parking/Turn Signal Light Bulb

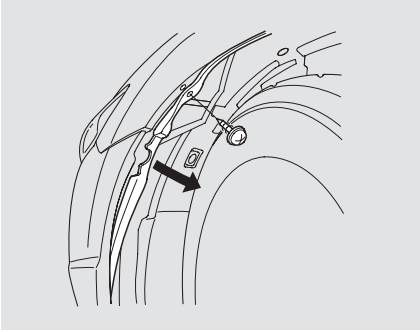

1. To change the driver's side bulb, start the engine, turn the steering wheel all the way to the right, and turn off the engine. To change the passenger's side bulb, turn the steering wheel to the left.

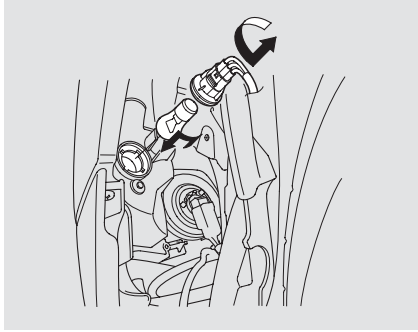

2. Use a Phillips-head screwdriver to remove the screw from the inner fender, and pull the inner fender cover back.
3. Remove the socket from the headlight assembly by turning it one-quarter turn counterclockwise.

4. Remove the bulb from the socket by pushing the bulb in and turning it counterclockwise until it unlocks.
5. Install the new bulb in the socket. Turn it clockwise to lock it in place.
6. Insert the socket back into the headlight assembly. Turn it clockwise to lock it in place.
7. Turn on the lights to make sure the new bulb is working.
8. Reinstall the inner fender cover. Then reinstall the screw and tighten it securely.

Lights

Replacing Rear Bulbs

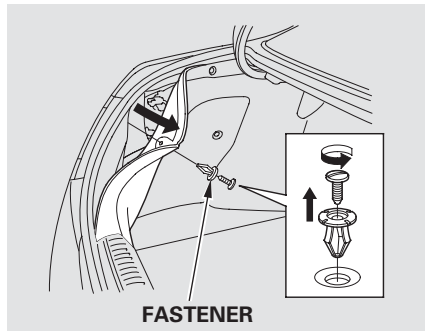

1. Open the trunk.

Remove the screw in the center of the fastener on the side of the trunk lining. Pull the lining back.

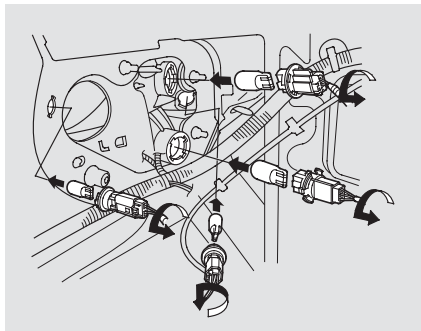

2. Determine which of the four bulbs is burned out: stop/taillight, back-up light, side marker light, or turn signal light.
3. Remove the socket by turning it one-quarter turn counterclockwise.

4. Pull the bulb straight out of its socket. Push the new bulb straight into the socket until it bottoms.
5. Reinstall the socket into the light assembly by turning it clockwise until it locks.
6. Turn on the lights to make sure the new bulb is working.
7. Reinstall the trunk lining. Make sure it is installed under the edge of the trunk seal.
8. Put the fastener into the hole on the side of the trunk lining. Reinstall the screw.

Replacing a Fog Light Bulb

If equipped

Your vehicle uses halogen light bulbs. When replacing a bulb, handle it by its plastic case, and protect the glass from contact with your skin or hard objects. If you touch the glass, clean it with denatured alcohol and a clean cloth.

NOTICE

Halogen light bulbs get very hot when lit. Oil, perspiration, or a scratch on the glass can cause the bulb to overheat and shatter.

The fog lights were properly aimed when your vehicle was new. If you regularly carry heavy items in the trunk, readjustment may be required. Adjustment should be done by your dealer or another qualified technician.

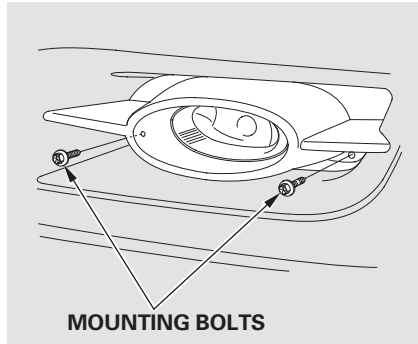

1. Remove the mounting bolts with a wrench.

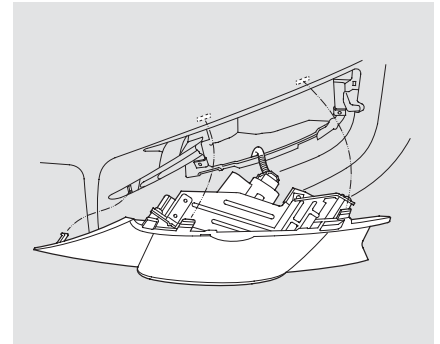

2. Pull the fog light assembly from the bumper while taking out the tabs from the bracket.

CONTINUED

Lights

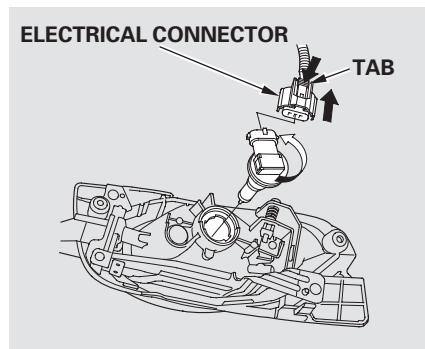

3. Remove the electrical connector from the bulb by pushing on the tab and pulling the connector down.
4. Remove the bulb from the fog light assembly by turning it one-quarter turn counterclockwise.

5. Insert the new bulb into the hole, and turn it one-quarter turn clockwise to lock it in place.
6. Push the electrical connector back onto the bulb. Make sure it is on all the way.
7. Turn on the fog lights to test the new bulb.
8. Reinstall the fog light assembly into the bumper while setting the tabs in the bracket. Tighten the mounting bolts securely.

Rear License Plate Light Bulbs

The license plate has two lights above it. You can access either of them from the back of the trunk lid. If your vehicle has a trunk lining, these bulbs should be replaced by your dealer.

Replacing a High-mount Brake Light Bulb

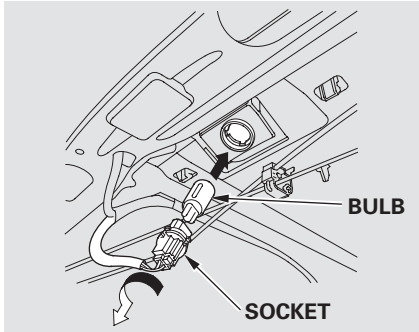

On DX, DX-G, LX, and SE models

1. Open the trunk, then remove the holding clips from the cover, and remove the cover.
2. Remove the socket from the light assembly by turning it one-quarter turn counterclockwise.

3. Pull the bulb straight out of its socket. Push the new bulb straight into the socket until it bottoms.
4. Reinstall the socket. Turn it clockwise until it locks. Make sure the new bulb is working.
5. Reinstall the cover, and tighten its holding clips securely.

On EX, EX-L, and Si models

The high-mount brake light should be replaced by your dealer.

Cleaning the Seat Belts

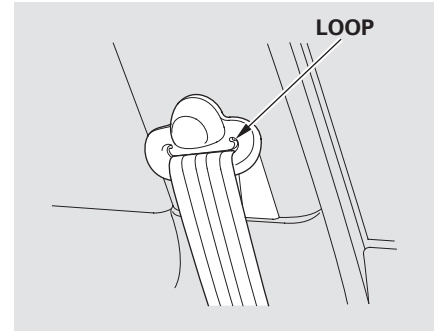

If your seat belts get dirty, use a soft brush with a mixture of mild soap and warm water to clean them. Do not use bleach, dye, or cleaning solvents. Let the belts air-dry before you use the vehicle.

CONTINUED

Cleaning the Seat Belts, Floor Mats

Dirt build-up in the loops of the seat belt anchors can cause the belts to retract slowly. Wipe the insides of the loops with a clean cloth dampened in mild soap and warm water or isopropyl alcohol.

Floor Mats

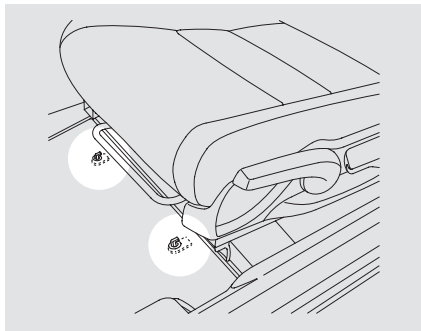

If equipped

The driver's and right rear passenger's floor mats that came with your vehicle hook over the floor mat anchors. This keeps the floor mats from sliding forward and possibly interfering with the pedals (driver's floor mat) or with the seat weight sensors (right rear floor mat).

If you remove a floor mat, make sure to re-anchor it when you put it back in your vehicle.

If you use a non-Honda floor mat, make sure it fits properly and that it can be used with the floor mat anchors. Do not put additional floor mats on top of the anchored mat.

Dust and Pollen Filter

On models with A/C

This filter removes the dust and pollen that is brought in from the outside through the heating and cooling system.

Have your dealer replace the filter when this service is indicated by a maintenance message on the information display. It should be replaced every 15,000 miles (24,000 km) if you drive primarily in urban areas that have high concentrations of soot in the air, or if the flow from the heating and cooling system becomes less than usual.

Wiper Blades

Check the condition of the wiper blades at least every six months. Replace them if you find signs of cracking in the rubber, areas that are getting hard, or if they leave streaks and unwiped areas when used.

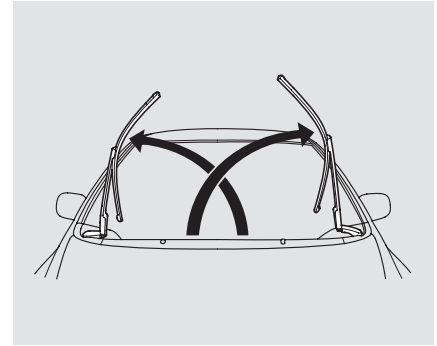

To replace a wiper blade:

1. Raise each wiper arm off the windshield, lifting the driver's side first, then the passenger's side.

NOTICE

Do not open the hood when the wiper arms are raised, or you will damage the hood and wiper arms.

CONTINUED

Wiper Blades

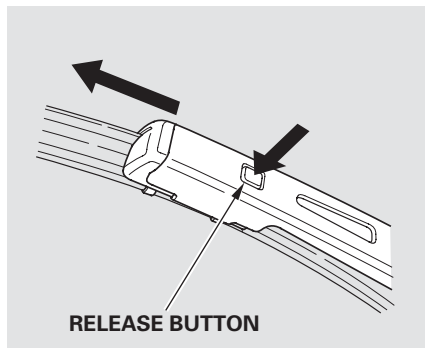

2. Disconnect the blade assembly from the wiper arm by pushing in the release button. Then slide the blade assembly out of the wiper arm.

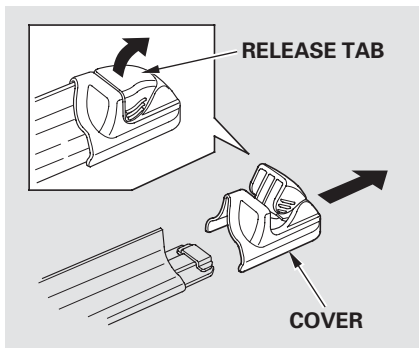

3. Pull up the cover release tab on the end of the blade assembly, then remove the cover.

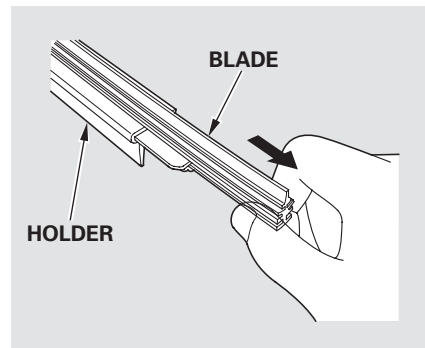

4. Slide the blade out of the holder.

5. Align the slots in the new blade with the retaining edges on the holder, then slide the blade onto the holder. Keep about 1 inch of the holder extended from the blade assembly so you can reinstall the cover.
6. Reinstall the cover onto the blade assembly.
7. Slide the wiper blade assembly onto the wiper arm. Make sure it locks in place.
8. Lower the wiper arm down against the windshield, the passenger's side first, then the driver's side.

Tires

To safely operate your vehicle, your tires must be the proper type and size, in good condition with adequate tread, and correctly inflated.

The following pages give more detailed information on how to take care of your tires and what to do when they need to be replaced.

⚠ WARNING

Using tires that are excessively worn or improperly inflated can cause a crash in which you can be seriously hurt or killed.

Follow all instructions in this owner's manual regarding tire inflation and maintenance.

Inflation Guidelines

Keeping the tires properly inflated provides the best combination of handling, tread life, and riding comfort.

- Underinflated tires wear unevenly, adversely affect handling and fuel economy, and are more likely to fail from being overheated.
- Overinflated tires can make your vehicle ride more harshly, are more prone to damage from road hazards, and wear unevenly.

CONTINUED

Tires

We recommend that you visually check your tires every day. If you think a tire might be low, check it immediately with a tire gauge.

U.S. models

The tire pressure monitoring system (TPMS) warns you when a tire pressure is low. See page 284 for more information.

Even though your vehicle is equipped with TPMS, we recommend that you visually check your tires every day.

Use a gauge to measure the air pressure in each tire at least once a month. Even tires that are in good condition may lose 1 to 2 psi (10 to 20 kPa, 0.1 to 0.2 kgf/cm²) per month. Remember to check the spare tire at the same time.

Check the air pressures when the tires are cold. This means the vehicle has been parked for at least 3 hours, or driven less than 1 mile (1.6 km). Add or release air, if needed, to match the recommended cold tire pressures on this page.

If you check air pressures when the tires are hot (driven for several miles/kilometers), you will see readings 4 to 6 psi (30 to 40 kPa, 0.3 to 0.4 kgf/cm²) higher than the cold readings. This is normal. Do not let air out to match the recommended cold air pressure. The tire will be underinflated.

You should get your own tire pressure gauge and use it whenever you check your tire pressures. This will make it easier for you to tell if a pressure loss is due to a tire problem and not due to a variation between gauges.

While tubeless tires have some ability to self-seal if they are punctured, you should look closely for punctures if a tire starts losing pressure.

Recommended Tire Pressures

The following charts show the recommended cold tire pressures for most normal driving conditions.

DX and Canadian DX-G with automatic transmission

Tire Size	Cold Tire Pressure
P195/65R15 89H	Front/Rear 32 psi (220 kPa , 2.2 kgf/cm ²)

Canadian DX-G with manual transmission

Tire Size	Cold Tire Pressure
P195/65R15 89S	Front/Rear 32 psi (220 kPa , 2.2 kgf/cm ²)

LX, SE, EX, EX-L

Tire Size	Cold Tire Pressure
P205/55R16 89H	Front/Rear 32 psi (220 kPa , 2.2 kgf/cm ²)

Si

Tire Size	Cold Tire Pressure
P215/45R17 87V	Front/Rear 32 psi (220 kPa , 2.2 kgf/cm ²)

Optional Summer Tire for U.S. Si

Tire Size	Cold Tire Pressure
215/45ZR17 91W	Front/Rear 32 psi (220 kPa , 2.2 kgf/cm ²)

The compact spare tire pressure is:
60 psi (420 kPa , 4.2 kgf/cm²)

For convenience, the recommended tire sizes and cold tire pressures are on a label on the driver's doorjamb. For additional information about your tires, see page 367 .

High Speed Driving

Si model only

We strongly recommend that you do not drive faster than the posted speed limits and conditions allow. If you ever drive in a sanctioned competitive event at sustained high speeds (over 118 mph or 190 km/h), be sure to adjust the cold tire pressures as shown below. If you do not, excessive heat can build up and cause sudden tire failure.

Tire Size-Cold Tire Pressure for High Speed Driving

Si model only

P215/45R17 87V

Front/Rear:

35 psi (240 kPa , 2.4 kgf/cm²)

CONTINUED

Tires

When you return to normal speed driving, be sure to readjust the tire pressure for normal driving. You should wait until the tires are cold before adjusting the tire pressure.

Except Si model

Tire pressure for high speed driving is the same as for normal driving.

Tire Inspection

Every time you check inflation, you should also examine the tires for damage, foreign objects, and wear.

You should look for:

- Bumps or bulges in the tread or side of the tire. Replace the tire if you find either of these conditions.
- Cuts, splits, or cracks in the side of the tire. Replace the tire if you can see fabric or cord.
- Excessive tread wear.

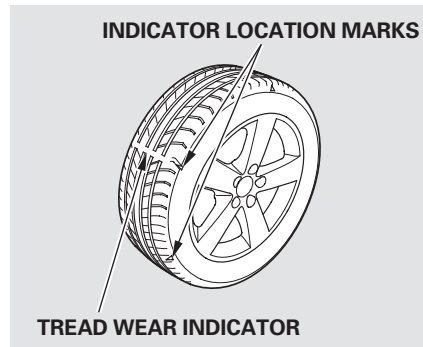

Your tires have wear indicators molded into the tread. When the tread wears down, you will see a 1/2 inch (12.7 mm) wide band across the tread. This shows there is less than 1/16 inch (1.6 mm) of tread left on the tire.

A tire this worn gives very little traction on wet roads. You should replace the tire if you can see three or more tread wear indicators.

Tire Service Life

The service life of your tires is dependent on many factors, including, but not limited to, driving habits, road conditions, vehicle loading, inflation pressure, maintenance history, speed, and environmental conditions (even when the tires are not in use).

In addition to your regular inspections and inflation pressure maintenance, it is recommended that you have annual inspections performed once the tires reach five years old. It is also recommended that all tires, including the spare, be removed from service after 10 years from the date of manufacture, regardless of their condition or state of wear.

The last four digits of the TIN (tire identification number) are found on the sidewall of the tire and indicate the date of manufacture (See **Tire Labeling** on page 369).

Tire Maintenance

In addition to proper inflation, correct wheel alignment helps to decrease tire wear. If you find a tire is worn unevenly, have your dealer check the wheel alignment.

Have your dealer check the tires if you feel a consistent vibration while driving. A tire should always be rebalanced if it is removed from the wheel. When you have new tires installed, make sure they are balanced. This increases riding comfort and tire life. For best results, have the installer perform a dynamic balance.

On models with aluminum wheels

NOTICE

Improper wheel weights can damage your vehicle's aluminum wheels. Use only Honda wheel weights for balancing.

Tires

Tire Rotation

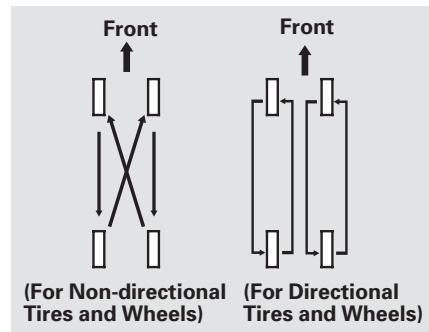

To help increase tire life and distribute wear more evenly, rotate the tires according to the maintenance messages displayed on the information display. Move the tires to the positions shown in the illustration each time they are rotated. If you purchase directional tires, rotate only front-to-back.

When the tires are rotated, make sure the air pressures are checked.

Tire Wear

Si model only

The tires that came on your vehicle were designed and constructed to provide superior grip during acceleration, braking, and cornering.

As a trade-off, they will wear more rapidly than tires used on ordinary passenger vehicles. Because of the vehicle's weight distribution, and the fact that the front wheels are the driving wheels, you can expect them to wear more rapidly than the rear tires.

The mileage you can expect from your vehicle tires is the same as comparable mid-and rear-engine sports cars, and it will vary greatly with your driving habits.

If you drive moderately, the front tires could last more than 10,000 miles (16,000 km). However, the mileage will be substantially less if you tend to drive your vehicle at the upper limits of its capabilities.

You should carefully inspect your vehicle's tires for wear, damage, and proper inflation every 7,500 miles (12,000 km).

Replacing Tires and Wheels

Replace your tires with radial tires of the same size, load range, speed rating, and maximum cold tire pressure rating (as shown on the tire's sidewall).

Mixing radial and bias-ply tires on your vehicle can reduce braking ability, traction, and steering accuracy. Using tires of a different size or construction can cause the ABS and vehicle stability assist system (VSA) to work inconsistently.

The ABS and VSA system (if equipped) work by comparing the speed of each wheel. When replacing tires, use the same size originally supplied with the vehicle. Tire size and construction can affect wheel speed and may cause the system to activate.

It is best to replace all four tires at the same time. If that is not possible or necessary, replace the two front tires or two rear tires as a pair. Replacing just one tire can seriously affect your vehicle's handling.

If you ever replace a wheel, make sure that the wheel's specifications match those of the original wheels.

On vehicles with TPMS

Also be sure you use only TPMS specific wheels. If you do not, the tire pressure monitoring system will not work.

Replacement wheels are available at your dealer.

WARNING

Installing improper tires on your vehicle can affect handling and stability. This can cause a crash in which you can be seriously hurt or killed.

Always use the size and type of tires recommended in this owner's manual.

Tires

Wheel and Tire Specifications

Wheels:

DX and Canadian DX-G
15 x 6J

LX, SE, EX, EX-L
16 x 6 1/2J

Si
17 x 7J

Tires:

DX and Canadian DX-G with
automatic transmission
P195/65R15 89H

Canadian DX-G with manual
transmission
P195/65R15 89S

LX, SE, EX, EX-L
P205/55R16 89H

Si
P215/45R17 87V
(all season tire)
Optional for U.S. Si
215/45ZR17 91W
(summer tire)

See page 367 for information about
DOT Tire Quality Grading, and page
369 for tire size and labeling
information.

Winter Driving

Tires marked “M + S” or “All
Season” on the sidewall have an all-
weather tread design suitable for
most winter driving conditions.

For the best performance in snowy
or icy conditions, you should install
snow tires or tire chains. They may
be required by local laws under
certain conditions.

Summer Tires

Si model only

If your vehicle is equipped with
summer tires, be aware that these
tires are not designed for winter
driving conditions. For more
information, consult your dealer.

Snow Tires

If you mount snow tires on your vehicle, make sure they are radial tires of the same size and load range as original tires. Mount snow tires on all four wheels. The traction provided by snow tires on dry roads may be lower than your original tires. Check with the tire dealer for maximum speed recommendations.

Tire Chains

Mount tire chains on your tires when required by driving conditions or local laws. Install them only on the front tires.

Because your vehicle has limited tire clearance, Honda strongly recommends using the chains listed below, made by Security Chain Company (SCC).

DX, Canadian DX-G
Cable-type: SCC Radial Chain
SC1030

LX, SE, EX, EX-L, Si
Cable-type: SCC Radial Chain
SC1032

When installing chains, follow the manufacturer's instructions, and mount them as tight as you can. Make sure they are not contacting the brake lines or suspension. Drive slowly with them installed. If you hear them coming into contact with the body or chassis, stop and investigate. Remove them as soon as you begin driving on cleared roads.

CONTINUED

NOTICE

Traction devices that are the wrong size or improperly installed can damage your vehicle's brake lines, suspension, body, and wheels. Stop driving if they are hitting any part of the vehicle.

⚠ WARNING

Using the wrong chains, or not properly installing chains, can damage the brake lines and cause a crash in which you can be seriously injured or killed.

Follow all instructions in this owner's manual regarding the selection and use of tire chains.

Wheels

Clean the wheels as you would the rest of the exterior. Wash them with the same solution, and rinse them thoroughly.

If equipped

Aluminum alloy wheels have a protective clear-coat that keeps the aluminum from corroding and tarnishing. Cleaning the wheels with harsh chemicals (including some commercial wheel cleaners) or a stiff brush can damage the clear-coat. To clean the wheels, use a mild detergent and a soft brush or sponge.

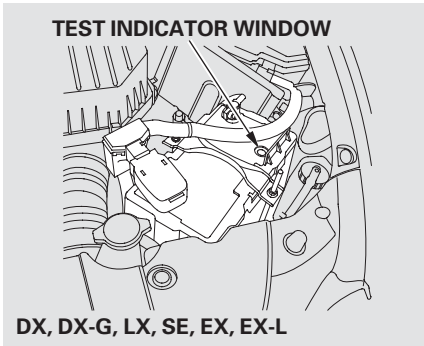

Check the condition of the battery monthly by looking at the test indicator window. The label on the battery explains the test indicator's colors.

The location of the test indicator window varies between manufacturers.

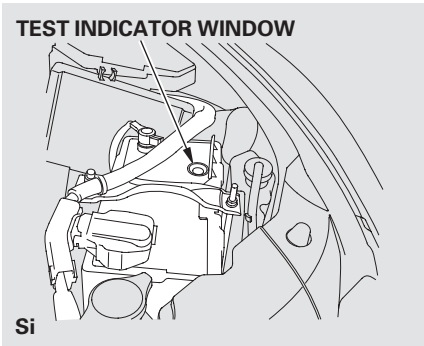

Check the terminals for corrosion (a white or yellowish powder). To remove it, cover the terminals with a solution of baking soda and water. It will bubble up and turn brown. When this stops, wash it off with plain water. Dry off the battery with a cloth or paper towel. Coat the terminals with grease to help prevent further corrosion.

If additional battery maintenance is needed, see your dealer or a qualified technician.

WARNING: Battery posts, terminals, and related accessories contain lead and lead compounds. **Wash your hands after handling.**

CONTINUED

Checking the Battery

If you need to connect the battery to a charger, disconnect both cables to prevent damaging your vehicle's electrical system. Always disconnect the negative (–) cable first, and reconnect it last.

⚠ WARNING

The battery gives off explosive hydrogen gas during normal operation.

A spark or flame can cause the battery to explode with enough force to kill or seriously hurt you.

Wear protective clothing and a face shield, or have a skilled technician do the battery maintenance.

If your vehicle's battery is disconnected or goes dead, the audio system may disable itself. The next time you turn on the radio, you will see "ENTER CODE" in the frequency display. Use the preset buttons to enter the code (see page 221).

If your vehicle's battery is disconnected, or goes dead, the time setting may be lost. To reset the time, see page 222 .

On models with navigation system
The navigation system will also disable itself. The next time you turn on the ignition switch, the system will require you to enter a PIN before it can be used. Refer to the navigation system manual.

If you need to park your vehicle for an extended period (more than 1 month), there are several things you should do to prepare it for storage. Proper preparation helps prevent deterioration and makes it easier to get your vehicle back on the road. If possible, store your vehicle indoors.

- Fill the fuel tank.
- Wash and dry the exterior completely.
- Clean the interior. Make sure the carpeting, floor mats, etc., are completely dry.
- Leave the parking brake off. Put the transmission in reverse (manual) or Park (automatic).
- Block the rear wheels.
- If the vehicle is to be stored for a longer period, it should be supported on jackstands so the tires are off the ground.
- Leave one window open slightly (if the vehicle is being stored indoors).
- Disconnect the battery.
- Support the front wiper blade arms with a folded towel or rag so they do not touch the windshield.
- To minimize sticking, apply a silicone spray lubricant to all door and trunk seals. Also, apply a vehicle body wax to the painted surfaces that mate with the door and trunk seals.
- Cover the vehicle with a “breathable” cover, one made from a porous material such as cotton. Non-porous materials, such as plastic sheeting, trap moisture, which can damage the paint.
- If possible, periodically run the engine until it reaches full operating temperature (the cooling fans cycle on and off twice). Preferably, do this once a month.

Interior Care

Leather

If equipped

Vacuum dirt and dust from the leather frequently. Pay close attention to the pleats and seams. Clean the leather with a soft cloth dampened with a 90% water and 10% neutral wool detergent solution. Then buff it with a clean, dry cloth. Remove any dust or dirt on leather surfaces immediately.

This section covers the more common problems that motorists experience with their vehicles. It gives you information about how to safely evaluate the problem and what to do to correct it. If the problem has stranded you on the side of the road, you may be able to get going again. If not, you will also find instructions on getting your vehicle towed.

- Compact Spare Tire..... 338
- Changing a Flat Tire 339
- If the Engine Won't Start..... 343
- Jump Starting 345
- If the Engine Overheats 347
- Low Oil Pressure Indicator 349
- Charging System Indicator..... 349
- Malfunction Indicator Lamp 350
- Brake System Indicator 351
- Fuses 352
- Fuse Locations..... 356
- Emergency Towing 358

Compact Spare Tire

Use the compact spare tire as a temporary replacement only. Get your regular tire repaired or replaced, and put it back on your vehicle as soon as you can.

Check the air pressure of the compact spare tire every time you check the other tires. It should be inflated to:

60 psi (420 kPa , 4.2 kgf/cm²)

Follow these precautions:

- Never exceed 50 mph (80 km/h).
- This tire gives a harsher ride and less traction on some road surfaces. Use greater caution while driving.

- Do not mount tire chains on the compact spare tire.
- Do not use your compact spare tire on another vehicle unless it is the same make and model.

On Si model

- Do not use a compact spare tire mounted on a front wheel; it will damage the limited slip differential (see page 339).

All U.S. models

- The low tire pressure indicator comes on and stays on after you replace the flat tire with the compact spare tire. After several miles (kilometers) driving with the compact spare tire, the TPMS indicator comes on and the low tire pressure indicator goes off.

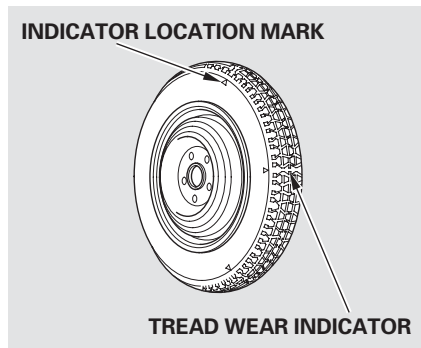

Replace the tire when you can see the tread wear indicator bars. The replacement tire should be the same size and design, mounted on the same wheel. The spare tire is not designed to be mounted on a regular wheel, and the spare wheel is not designed for mounting a regular tire.

If you have a flat tire while driving, pull over safely. Drive slowly along the shoulder until you get to an area far away from traffic lanes.

The compact spare tire is smaller than a standard tire, and it will affect the vehicle's handling. Drive cautiously when the spare is mounted on your vehicle.

On Si model only

The size difference may also cause damage to the differential, so do not mount the compact spare on the front. If either front tire goes flat, remove the rear tire on that same side, mount the compact spare tire on the rear, then mount the rear tire on the front.

⚠ WARNING

The vehicle can easily roll off the jack, seriously injuring anyone underneath.

Follow the directions for changing a tire exactly, and never get under the vehicle when it is supported only by the jack.

1. Park the vehicle on firm, level, and non-slippery ground. Put the transmission in Park (automatic) or reverse (manual). Apply the parking brake.
2. Turn on the hazard warning lights, and turn the ignition switch to the LOCK (0) position. Have all passengers get out of the vehicle while you change the tire.

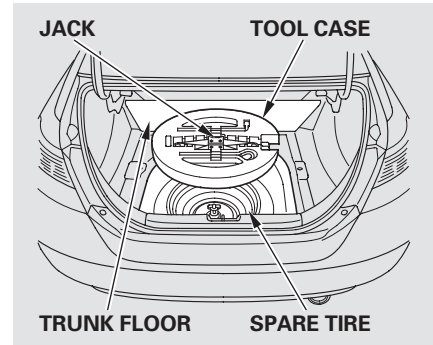

3. Open the trunk. Raise the trunk floor by lifting up on the back edge.
4. Take the tool kit case out of the trunk.
5. Unscrew the wing bolt, and take the spare tire out of its well.

CONTINUED

Changing a Flat Tire

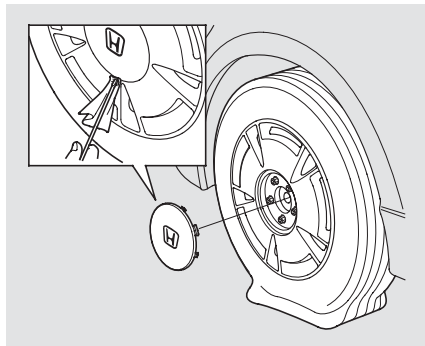

6. *Canadian DX-G model*
Remove the center cap from the wheel with the extension.



7. Loosen each wheel nut 1/2 turn with the wheel nut wrench.

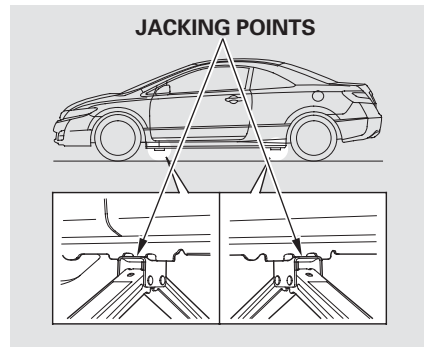

8. Place the jack under the jacking point nearest the tire you need to change. Turn the end bracket clockwise until the top of the jack contacts the jacking point. Make sure the jacking point tab is resting in the jack notch.

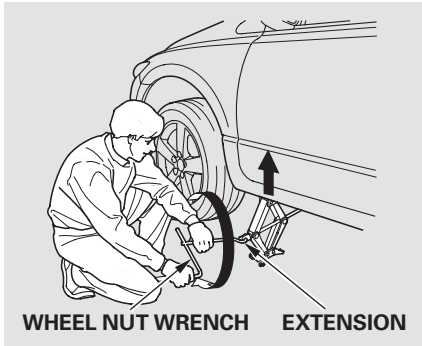

9. Use the extension and the wheel nut wrench as shown to raise the vehicle until the flat tire is off the ground.
10. Remove the wheel nuts, then remove the flat tire. Handle the wheel nuts carefully; they may be hot from driving. Place the flat tire on the ground with the outside surface facing up.

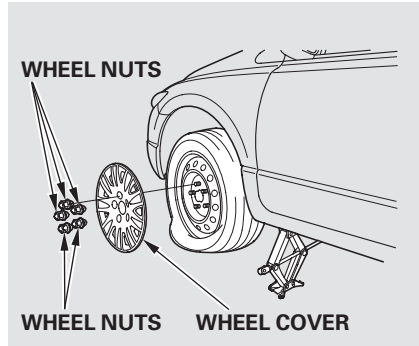

U.S. DX and LX models

Do not attempt to forcibly pry the wheel cover off with a screwdriver or other tool. The wheel cover cannot be removed without first removing the wheel nuts.

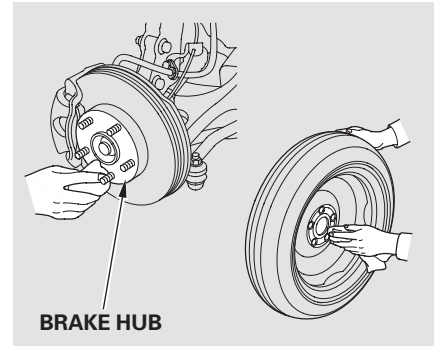

11. Before mounting the spare tire, wipe any dirt off the mounting surface of the wheel and hub with a clean cloth. Wipe the hub carefully; it may be hot from driving.

CONTINUED

Changing a Flat Tire



12. Put on the spare tire. Put the wheel nuts back on finger-tight, then tighten them in a crisscross pattern with the wheel nut wrench until the wheel is firmly against the hub. Do not try to tighten the wheel nuts fully.
13. Lower the vehicle to the ground, and remove the jack.

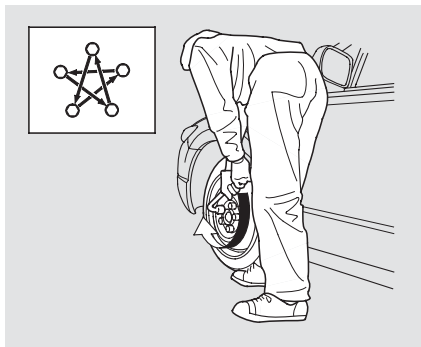

14. Tighten the wheel nuts securely in the same crisscross pattern. Have the wheel nut torque checked at the nearest automotive service facility.

Tighten the wheel nuts to:
80 lbf·ft (108 N·m , 11 kgf·m)

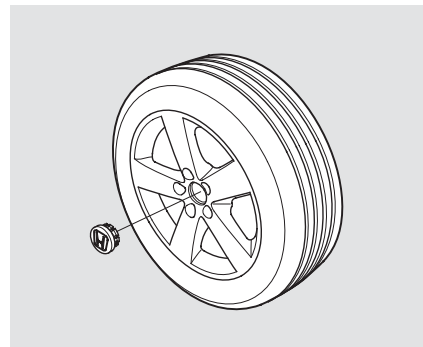

15. *On EX, EX-L and Si models in the U.S., and SE, EX-L and Si models in Canada* Remove the center cap from the flat tire.

Changing a Flat Tire, If the Engine Won't Start

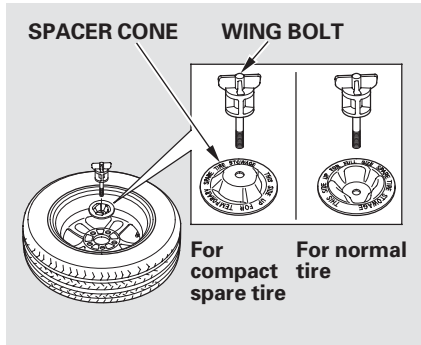

16. Place the flat tire face down in the spare tire well.
17. Remove the spacer cone from the wing bolt, turn it over, and put it back on the bolt.
18. Secure the flat tire by screwing the wing bolt back into its hole.
19. Store the jack and tools in the tool kit case. Place the tool kit case in the center of the flat tire.

⚠ WARNING

Loose items can fly around the interior in a crash and could seriously injure the occupants.

Store the wheel, jack, and tools securely before driving.

20. Store the wheel cover or center cap in the trunk. Make sure it does not get scratched or damaged.
21. Lower the trunk floor, then close the trunk lid.
22. *On all U.S. models*
Your vehicle's original tire has a tire pressure monitoring system sensor. To replace a tire, refer to **Changing a Tire with TPMS** (see page 286).

If the Engine Won't Start

Diagnosing why the engine won't start falls into two areas, depending on what you hear when you turn the ignition switch to the START (III) position:

- You hear nothing, or almost nothing. The engine's starter motor does not operate at all, or operates very slowly.
- You can hear the starter motor operating normally, or the starter motor sounds like it is spinning faster than normal, but the engine does not start up and run.

If the Engine Won't Start

Nothing Happens or the Starter Motor Operates Very Slowly

When you turn the ignition switch to the START (III) position, you do not hear the normal noise of the engine trying to start. You may hear a clicking sound, a series of clicks, or nothing at all.

Check these things:

- Check the transmission interlock. If you have a manual transmission, the clutch pedal must be pushed all the way to the floor or the starter will not operate. With an automatic transmission, it must be in Park or neutral.
- Turn the ignition switch to the ON (II) position. Turn on the headlights, and check their brightness. If the headlights are very dim or do not come on at all, the battery is discharged. See **Jump Starting** on page 345 .

- Turn the ignition switch to the START (III) position. If the headlights do not dim, check the condition of the fuses. If the fuses are OK, there is probably something wrong with the electrical circuit for the ignition switch or starter motor. You will need a qualified technician to determine the problem. See **Emergency Towing** on page 358 .

If the headlights dim noticeably or go out when you try to start the engine, either the battery is discharged or the connections are corroded. Check the condition of the battery and terminal connections (see page 333). You can then try jump starting the vehicle from a booster battery (see page 345).

The Starter Operates Normally

In this case, the starter motor's speed sounds normal, or even faster

than normal, when you turn the ignition switch to the START (III) position, but the engine does not run.

- Are you using a properly coded key? An improperly coded key will cause the immobilizer system indicator in the instrument panel to blink rapidly (see page 80).
- Are you using the proper starting procedure? Refer to **Starting the Engine** on page 270 .
- Do you have fuel? Check the fuel gauge; the low fuel indicator may not be working.
- There may be an electrical problem, such as no power to the fuel pump. Check all the fuses (see page 352).

If you find nothing wrong, you will need a qualified technician to find the problem. See **Emergency Towing** on page 358 .

Although this seems like a simple procedure, you should take several precautions.

⚠ WARNING

A battery can explode if you do not follow the correct procedure, seriously injuring anyone nearby.

Keep all sparks, open flames, and smoking materials away from the battery.

You cannot start a vehicle with an automatic transmission by pushing or pulling it.

To jump start your vehicle:

1. Open the hood, and check the physical condition of the battery. In very cold weather, check the condition of the electrolyte. If it seems slushy or frozen, do not try jump starting until it thaws.

NOTICE

If a battery sits in extreme cold, the electrolyte inside can freeze. Attempting to jump start with a frozen battery can cause it to rupture.

2. Turn off all the electrical accessories: heater, A/C, audio system, lights, etc. Put the transmission in neutral (manual) or Park (automatic), and set the parking brake.

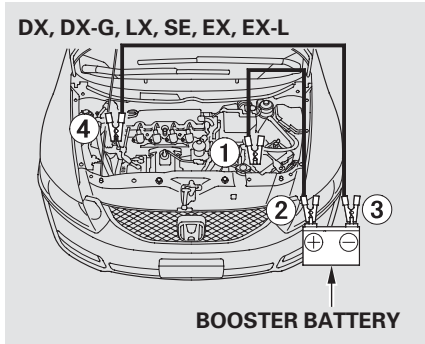

The numbers in the illustrations show you the order to connect the jumper cables.

CONTINUED

Jump Starting

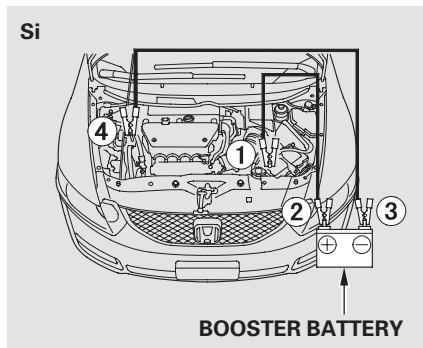

3. Connect one jumper cable to the positive (+) terminal on your battery. Connect the other end to the positive (+) terminal on the booster battery.

DX, DX-G, LX, SE, EX, EX-L

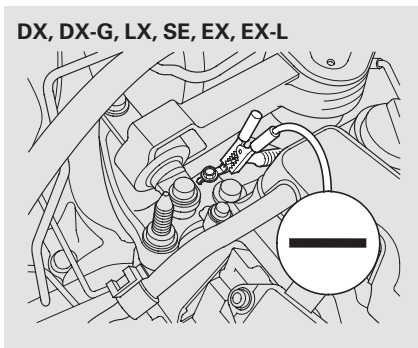

4. Connect the second jumper cable to the negative (-) terminal on the booster battery. Connect the other end to the grounding strap as shown. Do not connect this jumper cable to any other part of the engine.

5. If the booster battery is in another vehicle, have an assistant start that vehicle and run it at a fast idle.

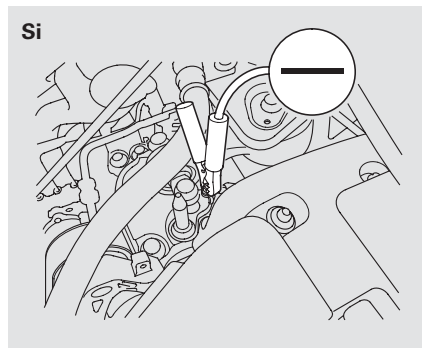

6. Start the vehicle. If the starter motor still operates slowly, check that the jumper cables have good metal-to-metal contact.

7. Once your vehicle is running, disconnect the negative cable from your vehicle, then from the booster battery. Disconnect the positive cable from your vehicle, then from the booster battery.

Keep the ends of the jumper cables away from each other and any metal on the vehicle until everything is disconnected. Otherwise, you may cause an electrical short.

If the Engine Overheats

The reading of the vehicle's temperature gauge should stay in the midrange. If it climbs to the red mark, you should determine the reason (hot day, driving up a steep hill, etc.).

If the vehicle overheats, you should take immediate action. The only indication may be the temperature gauge climbing to or above the red mark. Or you may see steam or spray coming from under the hood.

NOTICE

Driving with the temperature gauge reading at the red mark can cause serious damage to the engine.

⚠ WARNING

Steam and spray from an overheated engine can seriously scald you.

Do not open the hood if steam is coming out.

1. Safely pull to the side of the road. Put the transmission in neutral (manual) or Park (automatic), and set the parking brake. Turn off all accessories, and turn on the hazard warning lights.
2. If you see steam and/or spray coming from under the hood, turn off the engine. Wait until you see no more signs of steam or spray, then open the hood.

CONTINUED

If the Engine Overheats

3. If you do not see steam or spray, leave the engine running and watch the temperature gauge. If the high heat is due to overloading, the engine should start to cool down almost immediately. If it does, wait until the temperature gauge comes down to the midpoint, then continue driving.
 4. If the temperature gauge stays at the red mark, turn off the engine.
 5. Look for any obvious coolant leaks, such as a split radiator hose. Everything is still extremely hot, so use caution. If you find a leak, it must be repaired before you continue driving (see **Emergency Towing** on page 358).
 6. If you don't find an obvious leak, check the coolant level in the radiator reserve tank (see page 257). Add coolant if the level is below the MIN mark.
 7. If there was no coolant in the reserve tank, you may need to add coolant to the radiator. Let the engine cool down until the reading reaches the middle of the temperature gauge, or lower, before checking the radiator.
- ⚠ WARNING**

Removing the radiator cap while the engine is hot can cause the coolant to spray out, seriously scalding you.

Always let the engine and radiator cool down before removing the radiator cap.
8. Using gloves or a large heavy cloth, turn the radiator cap counterclockwise, without pushing down, to the first stop. After the pressure releases, push down on the cap, and turn it until it comes off.
 9. Start the engine, and set the temperature control dial to maximum heat. Add coolant to the radiator up to the base of the filler neck. If you do not have the proper coolant mixture available, you can add plain water. Remember to have the cooling system drained and refilled with the proper mixture as soon as you can.
 10. Put the radiator cap back on tightly. Run the engine, and check the temperature gauge. If it goes back to the red mark, the engine needs repair (see **Emergency Towing** on page 358).
 11. If the temperature stays normal, check the coolant level in the radiator reserve tank. If it has gone down, add coolant to the MAX mark. Put the cap back on tightly.



Low Oil Pressure Indicator

This indicator should never come on when the engine is running. If it starts flashing or stays on, the oil pressure has dropped very low or lost pressure. Serious engine damage is possible, and you should take immediate action.

NOTICE

Running the engine with low oil pressure can cause serious mechanical damage almost immediately. Turn off the engine as soon as you can safely get the vehicle stopped.

1. Safely pull off the road, and shut off the engine. Turn on the hazard warning indicators.
2. Let the vehicle sit for a minute. Open the hood, and check the oil level (see page 255). An engine very low on oil can lose pressure during cornering and other driving maneuvers.
3. If necessary, add oil to bring the level back to the full mark on the dipstick (see page 300).
4. Start the engine, and watch the oil pressure indicator. If it does not go out within 10 seconds, turn off the engine. There is a mechanical problem that needs to be repaired before you can continue driving (see **Emergency Towing** on page 358).



Charging System Indicator

If the charging system indicator comes on brightly when the engine is running, the battery is not being charged.

Immediately turn off all electrical accessories. Try not to use other electrically operated controls such as the power windows. Keep the engine running; starting the engine will discharge the battery rapidly.

Go to a service station or garage where you can get technical assistance.

Malfunction Indicator Lamp



If the indicator comes on while driving, it means one of the engine's emissions control systems may have a problem. Even though you may feel no difference in your vehicle's performance, it can reduce your fuel economy and cause increased emissions. Continued operation may cause serious damage.

If you have recently refueled your vehicle, the indicator coming on could be due to a loose or missing fuel fill cap. You will also see a "CHECK FUEL CAP" message on the information display. Tighten the cap until it clicks at least once. Tightening the cap will not turn the indicator off immediately; it can take several days of normal driving.

If the indicator comes on repeatedly, even though it may turn off as you continue driving, have your vehicle checked by the dealer as soon as possible.

NOTICE

If you keep driving with the malfunction indicator lamp on, you can damage your vehicle's emissions controls and engine. Those repairs may not be covered by your vehicle's warranties.

If your vehicle has an automatic transmission, the malfunction indicator lamp may also come on with the "D" indicator.

Readiness Codes

Your vehicle has certain "readiness codes" that are part of the on-board diagnostics for the emissions systems. In some states, part of the emissions testing is to make sure

these codes are set. If they are not set, the test cannot be completed.

If the battery in your vehicle has been disconnected or gone dead, these codes may be erased. It can take several days of driving under various conditions to set the codes again.

To check if they are set, turn the ignition switch to the ON (II) position, without starting the engine. The malfunction indicator lamp will come on for 20 seconds. If it then goes off, the readiness codes are set. If it blinks five times, the readiness codes are not set. If possible, do not take your vehicle for an emissions test until the readiness codes are set. Refer to **Emissions Testing** for more information (see page 376).

U.S.

BRAKE

Canada



The brake system indicator normally comes on when you turn the ignition switch to the ON (II) position and as a reminder to check the parking brake. It will stay on if you do not fully release the parking brake.

If the brake system indicator comes on while driving, the brake fluid level is probably low. Press lightly on the brake pedal to see if it feels normal. If it does, check the brake fluid level the next time you stop at a service station (see page 310).

If the fluid level is low, take your vehicle to a dealer, and have the brake system inspected for leaks or worn brake pads.

However, if the brake pedal does not feel normal, you should take immediate action. A problem in one part of the system's dual circuit design will still give you braking at two wheels. You will feel the brake pedal go down much farther before the vehicle begins to slow down, and you will have to press harder on the pedal.

Slow down by shifting to a lower gear, and pull to the side of the road when it is safe. Because of the long distance needed to stop, it is hazardous to drive the vehicle. You should have it towed and repaired as soon as possible (see **Emergency Towing** on page 358).

If you must drive the vehicle a short distance in this condition, drive slowly and carefully.

If the ABS indicator and the VSA system indicator (if equipped) come on with the brake system indicator, have your vehicle inspected by your dealer immediately.

Fuses

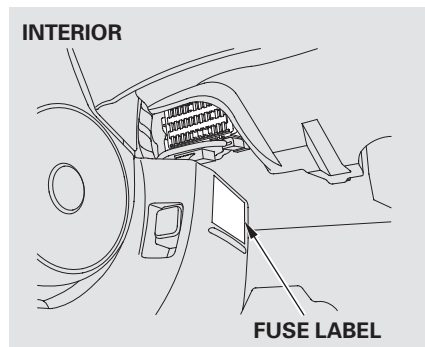

The vehicle's fuses are contained in two fuse boxes.

The interior fuse box is on the driver's lower left side.

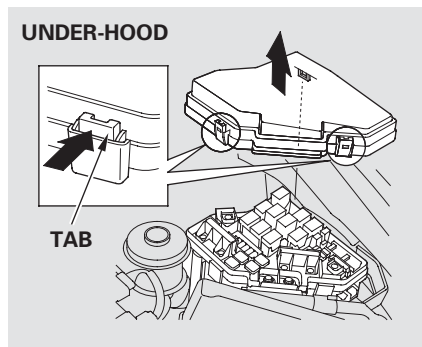

The under-hood fuse box is in the engine compartment on the driver's side, next to the brake fluid reservoir. To open it, push the tabs as shown.

Checking and Replacing Fuses

If something electrical in your vehicle stops working, check for a blown fuse first. Determine from the chart on pages 356 and 357, or the diagram on the fuse box lid, which fuse or fuses control that device. Check those fuses first, but check all the fuses before deciding that a blown fuse is the cause. Replace any blown fuses, and check if the device works.

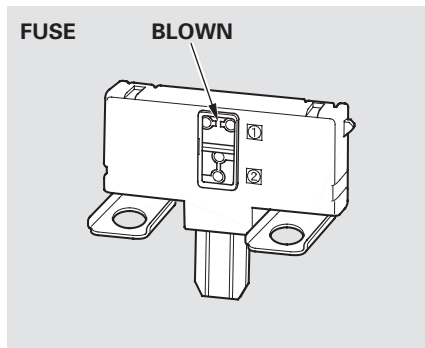

1. Turn the ignition switch to the LOCK (0) position. Make sure the headlights and all other accessories are off.
2. Remove the cover from the fuse box.

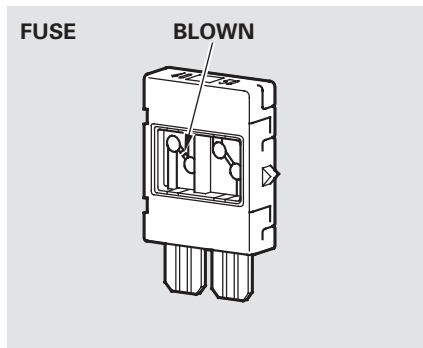

3. Check each of the large fuses in the under-hood fuse box by looking through the top at the wire inside. Removing these fuses requires a Phillips-head screw-driver.

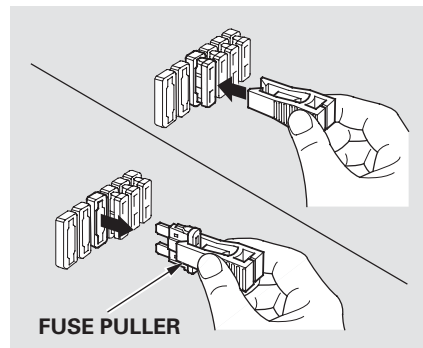

4. Check the smaller fuses in the under-hood fuse box and all the fuses in the interior fuse box by pulling out each one with the fuse puller provided on the back of the under-hood fuse box cover.

CONTINUED

Fuses

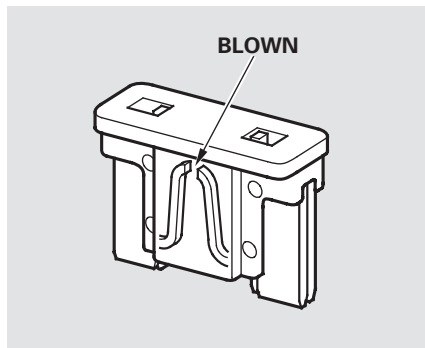

5. Look for a blown wire inside the fuse. If it is blown, replace it with one of the spare fuses of the same rating or lower.

If you cannot drive the vehicle without fixing the problem, and you do not have a spare fuse, take a fuse of the same rating or a lower rating from one of the other circuits. Make sure you can do without that circuit temporarily (such as the accessory power socket).

If you replace the blown fuse with a spare fuse that has a lower rating, it might blow out again. This does not indicate that anything is wrong. Replace the fuse with one of the correct rating as soon as you can.

NOTICE

Replacing a fuse with one that has a higher rating greatly increases the chances of damaging the electrical system. If you do not have a replacement fuse with the proper rating for the circuit, install one with a lower rating.

6. If the replacement fuse of the same rating blows in a short time, there is probably a serious electrical problem in your vehicle. Leave the blown fuse in that circuit and have your vehicle checked by a qualified technician.

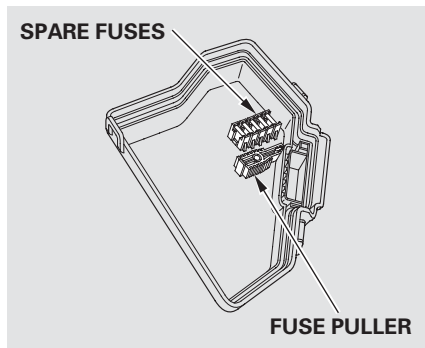

Your vehicle has spare fuses on the back of the under-hood fuse box cover.

All models except DX and Canadian DX-G

If the driver's power window fuse is removed, the AUTO function of the driver's window will be disabled. You should reset the AUTO feature (see page 105).

Fuse Locations

UNDER-HOOD FUSE BOX

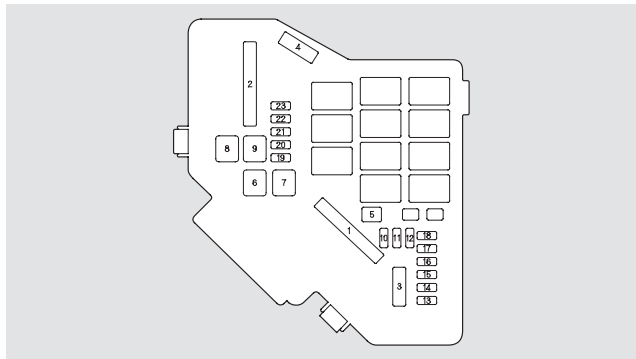

No.	Amps.	Circuits Protected
1	100 A	Main Fuse
	(70 A)	EPS*2
2	60 A	Option Main
	50 A	Ignition Switch Main
3	30 A	ABS/VSA Motor
	30 A	ABS/VSA F/S
	40 A*1	
4	50 A	Headlight Main
	40 A	Power Window Main

No.	Amps.	Circuits Protected
5	—	Not Used
6	20 A	Sub Fan Motor
7	30 A	Main Fan Motor (A/T)
	20 A	Main Fan Motor (M/T)
8	40 A	Rear Defroster
9	40 A	Blower
10	10 A	Hazard
11	15 A	FI Sub
12	15 A	Stop, Horn
13	—	Not Used
14	—	Not Used
15	7.5 A	Oil Level Sensor
16	—	Not Used
17	(15 A)	Audio Amp*2
18	15 A	Ignition Coil
19	15 A	FI Main
20	7.5 A	MG Clutch
21	15 A	DBW
22	7.5 A	Interior Light
23	10 A	Back Up

*1 : EX-L and Si models

*2 : If equipped

INTERIOR FUSE BOX

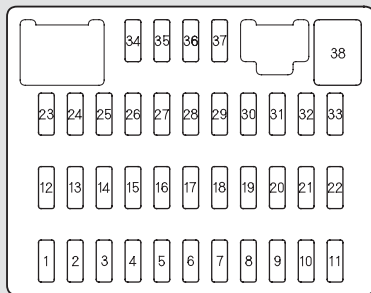

No.	Amps.	Circuits Protected
1	7.5 A	Power Window
2	15 A	Fuel Pump
3	10 A	IG1 ACG
4	7.5 A	ABS/VSA
5	(15 A)	Heated Seats*
6	(20 A)	Front Fog Lights*
7	(7.5 A)	TPMS*
8	—	Not Used

No.	Amps.	Circuits Protected
9	7.5 A	ODS (Occupant Detection System)
10	7.5 A	Meter
11	10 A	SRS
12	10 A	Right Headlight High Beam
13	10 A	Left Headlight High Beam
14	7.5 A	Small Lights (Interior)
15	7.5 A	Small Lights (Exterior)
16	10 A	Right Headlight Low Beam

No.	Amps.	Circuits Protected
17	10 A	Left Headlight Low Beam
18	20 A	Headlight High Beam Main
19	15 A	Small Lights Main
20	—	Not Used
21	20 A	Headlight Low Beam Main
22	—	Not Used
23	—	Not Used
24	(20 A)	Moonroof*
25	20 A	Door Lock
26	20 A	Driver's Power Window
27	(20 A)	HAC Option
28	(15 A)	Rear Accessory Socket*
29	15 A	Accessory
30	20 A	Front Passenger's Power Window
31	—	Not Used
32	—	Not Used
33	—	Not Used
34	—	Not Used
35	7.5 A	Accessory, Radio
36	10 A	IG2 HAC
37	7.5 A	Daytime Running Lights
38	30 A	Front Wiper

* : If equipped

Emergency Towing

If your vehicle needs to be towed, call a professional towing service or organization. Never tow your vehicle with just a rope or chain. It is very dangerous.

There are two ways to tow your vehicle:

Flat-bed Equipment – The operator loads your vehicle on the back of a truck. **This is the best way to transport your vehicle.**

Wheel-lift Equipment – The tow truck uses two pivoting arms that go under the front tires and lift them off the ground. The rear tires remain on the ground. **This is an acceptable way to tow your vehicle.**

If, due to damage, your vehicle must be towed with the front wheels on the ground, do this:

Manual transmission:

- Shift the transmission to neutral.
- Leave the ignition switch in the ACCESSORY (I) position so the steering wheel does not lock.
- Release the parking brake.

Automatic transmission:

- Start the engine.
- Shift to the D position and hold for 5 seconds, then to N.
- Turn off the engine.
- Leave the ignition switch in the ACCESSORY (I) position so the steering wheel does not lock.
- Release the parking brake.

NOTICE

Improper towing preparation will damage the transmission. Follow the above procedure exactly. If you cannot shift the transmission or start the engine (automatic transmission), your vehicle must be transported with the front wheels off the ground.

With the front wheels on the ground, do not tow the vehicle more than 50 miles (80 km), and keep the speed below 35 mph (55 km/h).

Do not tie down the vehicle at an angle that would allow the towing cables to contact the vehicle's front bumper. To avoid possible damage, protect the front bumper with tape.

If your vehicle is equipped with a front spoiler, remove it before towing so it is not damaged.

NOTICE

Trying to lift or tow your vehicle by the bumpers will cause serious damage. The bumpers are not designed to support the vehicle's weight.

NOTICE

The steering system can be damaged if the steering wheel is locked. Leave the ignition switch in the ACCESSORY (I) position, and make sure the steering wheel turns freely before you begin towing.

The diagrams in this section give you the dimensions and capacities of your vehicle and the locations of the identification numbers. It also includes information you should know about your vehicle's tires and emissions control systems.

Identification Numbers.....	362	Emissions Controls.....	373
Specifications	364	The Clean Air Act.....	373
DOT Tire Quality Grading		Crankcase Emissions Control	
(U.S. Vehicles)	367	System.....	373
Uniform Tire Quality		Evaporative Emissions Control	
Grading	367	System.....	373
Treadwear	367	Onboard Refueling Vapor	
Traction.....	367	Recovery	373
Temperature	368	Exhaust Emissions Controls ...	374
Tire Labeling.....	369	PGM-FI System	374
Tire Pressure Monitoring System		Ignition Timing Control	
(TPMS) – Required Federal		System.....	374
Explanation.....	371	Exhaust Gas Recirculation	
		(EGR) System.....	374
		Three Way Catalytic	
		Converter.....	374
		Replacement Parts.....	374
		Three Way Catalytic Converter ...	375
		Emissions Testing	376

Identification Numbers

Your vehicle has several identifying numbers located in various places.

The vehicle identification number (VIN) is the 17-digit number your dealer uses to register your vehicle for warranty purposes. It is also necessary for licensing and insuring your vehicle. The easiest place to find the VIN is on a plate fastened to the top of the dashboard. You can see it by looking through the windshield on the driver's side. It is also on the certification label attached to the driver's doorjamb, and is stamped on the engine compartment bulkhead. The VIN is also provided in bar code on the certification label.

To access the VIN in the engine compartment, slide the lid on the back of the engine compartment. Make sure to close the lid before closing the hood.

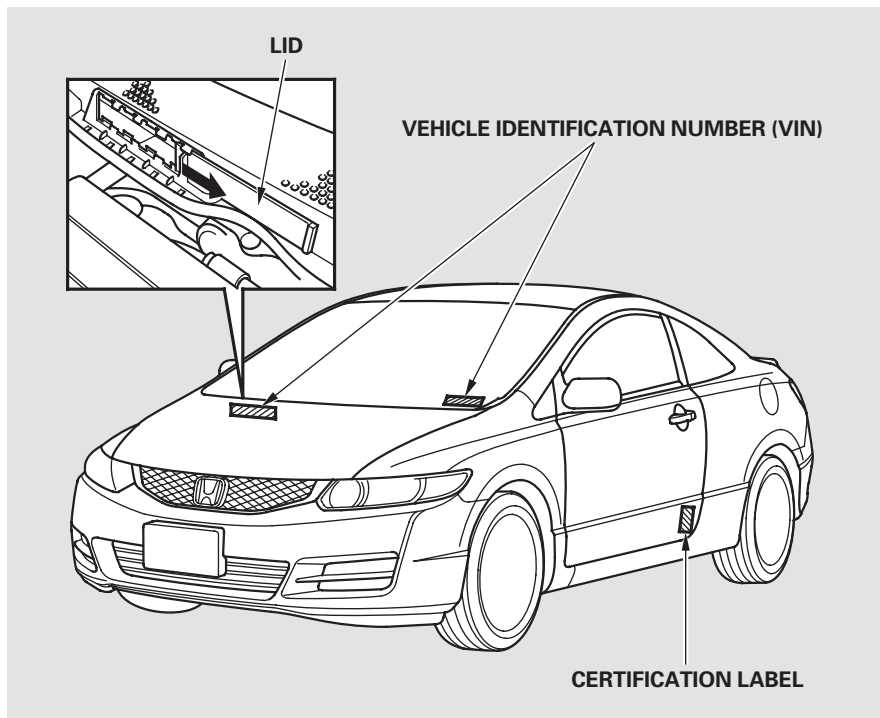

The engine number is stamped into the engine block. It is on the front.

The transmission number is on a label on top of the transmission.

DX, DX-G, LX, SE, EX, and EX-L

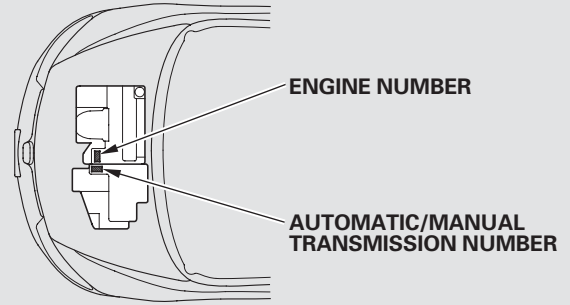

Si

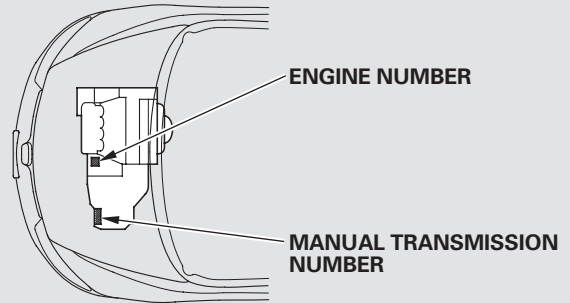

Specifications

Dimensions

Length	175.5 in (4,457 mm)	
Width	68.9 in (1,751 mm)	
Height	55.0 in (1,396 mm)	
Wheelbase	104.3 in (2,650 mm)	
Track	Front	59.0 in (1,499 mm)
	Rear	60.1 in (1,526 mm)

Seating Capacities

Total	5
Front	2
Rear	3

Weights

Gross vehicle weight rating	See the certification label attached to the driver's doorjamb.
-----------------------------	--

Engine

Type	Water cooled 4-stroke SOHC i-VTEC* ¹ , DOHC i-VTEC* ² 4-cylinder gasoline engine
Bore x Stroke	3.19 x 3.44 in (81.0 x 87.3 mm)* ¹ 3.39 x 3.39 in (86 x 86 mm)* ²
Displacement	110 cu-in (1,799 cm ³)* ¹ 122 cu-in (1,998 cm ³)* ²
Compression ratio	10.5* ¹ 11.0* ²
Spark plugs* ¹	NGK: IZFR6K-11S DENSO: SKJ20DR-M11S
Spark plugs* ²	NGK: IFR7G-11KS DENSO: SK22PR-M11S

* 1 : DX, DX-G, LX, SE, EX, EX-L

* 2 : Si

Capacities

Fuel tank		Approx. 13.2 US gal (50 l)
Engine coolant	Change* ¹	1.45 US gal (5.5 l) ^{*3, *4}
	A/T	1.37 US gal (5.2 l) ^{*3, *5}
	M/T	1.19 US gal (4.5 l) ^{*6}
Total	A/T	1.88 US gal (7.1 l) ^{*3, *4}
	M/T	1.72 US gal (6.5 l) ^{*3, *5}
Engine oil	Change* ²	
	Including filter	3.9 US qt (3.7 l) ^{*3, *4}
	Without filter	4.6 US qt (4.4 l) ^{*6}
	Total	3.7 US qt (3.5 l) ^{*3, *4}
Manual transmission fluid	Change	4.4 US qt (4.2 l) ^{*6}
	Total	4.8 US qt (4.5 l) ^{*3, *4}
		5.8 US qt (5.5 l) ^{*6}
Automatic transmission fluid	Change	1.5 US qt (1.4 l) ^{*3, *5}
	Total	1.6 US qt (1.5 l) ^{*6}
		1.7 US qt (1.6 l) ^{*3, *5}
Windshield washer reservoir	U.S. Vehicles	1.8 US qt (1.7 l) ^{*6}
	Canada Vehicles	2.5 US qt (2.4 l)
	Total	6.08 US qt (5.75 l)

* 1 : Including the coolant in the reserve tank and that remaining in the engine

Reserve tank capacity: 0.11 US gal (0.4 l)

* 2 : Excluding the oil remaining in the engine

* 3 : U.S.: DX, LX, EX, EX-L

* 4 : Canada: DX-G, SE, EX-L

* 5 : Canada: DX-G, SE

* 6 : Si

Air Conditioning

Refrigerant type	HFC-134a (R-134a)
Charge quantity	14.1 – 15.9 oz (400 – 450 g)
Lubricant oil type	SP-10

Lights

Headlights (HI)	12 V – 60 W (HB3)
Headlights (LO)	12 V – 51 W (HB4)
Front turn signal/Side marker/ Parking light	12 V – 28/8 W (Amber)
Fog lights* ²	12 V – 55 W (H11)
Rear turn signal lights	12 V – 21 W (Amber)
Stop/Taillights	12 V – 21/5 W
Rear side marker lights	12 V – 3 CP
Back-up lights	12 V – 18 W
High-mount brake light* ¹	12 V – 21 W
License plate lights	12 V – 3 CP
Ceiling light	12 V – 8 W
Spotlights	12 V – 8 W
Trunk light	12 V – 5 W

* 1 : U.S. DX and LX

Canada: DX-G, SE

EX, EX-L, Si: Replacement of the light should be done by your dealer.

* 2 : If equipped

Specifications

Battery

Capacity	12 V — 36 AH/5 HR *1
	12 V — 38 AH/5 HR *2, *3
	12 V — 45 AH/20 HR *1
	12 V — 47 AH/20 HR *2, *3

* 1 : U.S.: DX, LX, EX, EX-L

* 2 : Canada: DX-G, SE, EX-L

* 3 : Si

Fuses

Interior	See page 357 or the fuse label attached to the dashboard.
Under-hood	See page 356 or the fuse box cover.

Alignment

Toe-in	Front	0.00 in (0.0 mm)
	Rear	0.08 in (2.0 mm)
Camber	Front	0°
	Rear	-0°45' *1 -1°30' *2
Caster	Front	7°

* 1 : LX, Canadian DX-G (M/T), SE, EX, EX-L

* 2 : DX, Canadian DX-G (A/T)

Tires

Size	Front/Rear	P195/65R15 89H *1
		P195/65R15 89S *2
		P205/55R16 89H *3
		P215/45R17 87V *4
		215/45ZR17 91W *5
Spare		T125/70D15 95M *6
		T135/80R16 101M *7
Pressure	Front/Rear	32 psi (220 kPa , 2.2 kgf/cm ²)
	Spare	60 psi (420 kPa , 4.2 kgf/cm ²)

* 1 : U.S.: DX

Canada: DX-G with automatic transmission

* 2 : Canada: DX-G with manual transmission

* 3 : LX, SE, EX, EX-L

* 4 : Si (all season tires)

* 5 : Optional for U.S. Si (summer tires)

* 6 : U.S.: DX, LX, EX

Canada: DX-G, SE

* 7 : U.S.: EX-L and Si

Canada: EX-L and Si

The tires on your vehicle meet all U.S. Federal Safety Requirements. All tires are also graded for treadwear, traction, and temperature performance according to Department of Transportation (DOT) standards. The following explains these gradings.

Uniform Tire Quality Grading

Quality grades can be found where applicable on the tire sidewall between tread shoulder and maximum section width. For example:

Treadwear 200
Traction AA
Temperature A

All passenger car tires must conform to Federal Safety Requirements in addition to these grades.

Treadwear

The treadwear grade is a comparative rating based on the wear rate of the tire when tested under controlled conditions on a specified government test course. For example, a tire graded 150 would wear one and one-half (1 1/2) times as well on the government course as a tire graded 100. The relative performance of tires depends upon the actual conditions of their use, however, and may depart significantly from the norm due to variations in driving habits, service practices and differences in road characteristics and climate.

Traction

The traction grades, from highest to lowest, are AA, A, B, and C. Those grades represent the tire's ability to stop on wet pavement as measured under controlled conditions on specified government test surfaces of asphalt and concrete. A tire marked C may have poor traction performance.

Warning: The traction grade assigned to this tire is based on straight-ahead braking traction tests, and does not include acceleration, cornering, hydroplaning, or peak traction characteristics.

DOT Tire Quality Grading (U.S. Vehicles)

Temperature

The temperature grades are A (the highest), B, and C, representing the tire's resistance to the generation of heat and its ability to dissipate heat when tested under controlled conditions on a specified indoor laboratory test wheel. Sustained high temperature can cause the material of the tire to degenerate and reduce tire life, and excessive temperature can lead to sudden tire failure. The grade C corresponds to a level of performance which all passenger car tires must meet under the Federal Motor Vehicle Safety Standard No. 109. Grades B and A represent higher levels of performance on the laboratory test wheel than the minimum required by law.

Warning: The temperature grade for this tire is established for a tire that is properly inflated and not overloaded. Excessive speed, underinflation, or excessive loading, either separately or in combination, can cause heat buildup and possible tire failure.

The tires that came on your vehicle have a number of markings. Those you should be aware of are described below.

Tire Labeling Example

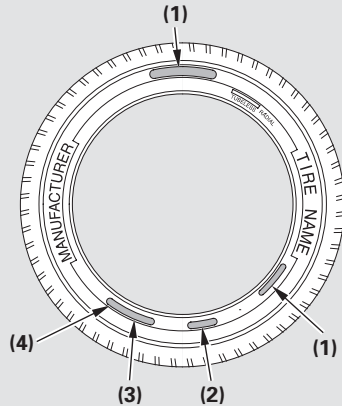

- (1) Tire Size
- (2) Tire Identification Number (TIN)
- (3) Maximum Tire Pressure
- (4) Maximum Tire Load

Tire Size

Whenever tires are replaced, they should be replaced with tires of the same size. Following is an example of tire size with an explanation of what each component means.

P205/55R16 89H

- P – Vehicle type (P indicates passenger vehicle).
- 205 – Tire width in millimeters.
- 55 – Aspect ratio (the tire's section height as a percentage of its width).
- R – Tire construction code (R indicates radial).
- 16 – Rim diameter in inches.

- 89 – Load index (a numerical code associated with the maximum load the tire can carry).
- H – Speed symbol (an alphabetical code indicating the maximum speed rating).

CONTINUED

Tire Labeling

Tire Identification Number (TIN)

The tire identification number (TIN) is a group of numbers and letters that look like the following example. TIN is located on the sidewall of the tire.

DOT B97R FW6X 2202

DOT — This indicates that the tire meets all requirements of the U.S. Department of Transportation.

B97R — Manufacturer's identification mark.

FW6X — Tire type code.

2202 — Date of manufacture.
└───┬───┬───
 Year
 Week

Glossary of Tire Terminology

Cold Tire Pressure — The tire air pressure when the vehicle has been parked for at least three hours or driven less than 1 mile (1.6 km).

Load Rating — Means the maximum load that a tire is rated to carry for a given inflation pressure.

Maximum Inflation Pressure — The maximum tire air pressure that the tire can hold.

Maximum Load Rating — Means the load rating for a tire at the maximum permissible inflation pressure for that tire.

Recommended Inflation Pressure — The cold tire inflation pressure recommended by the manufacturer.

Treadwear Indicators (TWI) — Means the projections within the principal grooves designed to give a visual indication of the degrees of wear of the tread.

Tire Pressure Monitoring System (TPMS) – Required Federal Explanation

U.S. models only

Each tire, including the spare (if provided), should be checked monthly when cold and inflated to the inflation pressure recommended by the vehicle manufacturer on the vehicle placard or tire inflation pressure label.

(If your vehicle has tires of a different size than the size indicated on the vehicle placard or tire inflation pressure label, you should determine the proper tire inflation pressure for those tires.)

As an added safety feature, your vehicle has been equipped with a tire pressure monitoring system (TPMS) that illuminates a low tire pressure telltale



when one or more of your tires is significantly under-inflated.

Accordingly, when the low tire pressure telltale illuminates, you should stop and check your tires as soon as possible, and inflate them to the proper pressure.

Driving on a significantly under-inflated tire causes the tire to overheat and can lead to tire failure. Under-inflation also reduces fuel efficiency and tire tread life, and may affect the vehicle's handling and stopping ability.

Please note that the TPMS is not a substitute for proper tire maintenance, and it is the driver's responsibility to maintain correct tire pressure, even if under-inflation has not reached the level to trigger illumination of the TPMS low tire pressure telltale.

CONTINUED

Tire Pressure Monitoring System (TPMS) – Required Federal Explanation

Your vehicle has also been equipped with a TPMS malfunction indicator to indicate when the system is not operating properly. The TPMS malfunction indicator is provided by a separate telltale, which displays the symbol “TPMS” when illuminated.

When the malfunction indicator is illuminated,

TPMS

the system may not be able to detect or signal low tire pressure as intended.

TPMS malfunctions may occur for a variety of reasons, including the installation of replacement or alternate tires or wheels on the vehicle that prevent the TPMS from functioning properly.

Always check the TPMS malfunction telltale after replacing one or more tires or wheels on your vehicle to ensure that the replacement or alternate tires and wheels allow the TPMS to continue to function properly.

The burning of gasoline in your vehicle's engine produces several by-products. Some of these are carbon monoxide (CO), oxides of nitrogen (NO_x), and hydrocarbons (HC). Gasoline evaporating from the tank also produces hydrocarbons. Controlling the production of NO_x, CO, and HC is important to the environment. Under certain conditions of sunlight and climate, NO_x and HC react to form photochemical "smog." Carbon monoxide does not contribute to smog creation, but it is a poisonous gas.

The Clean Air Act

The United States Clean Air Act* sets standards for automobile emissions. It also requires that automobile manufacturers explain to owners how their emissions controls work and what to do to maintain them. This section summarizes how the emissions controls work.

* In Canada, Honda vehicles comply with the Canadian emission requirements, as specified in an agreement with Environment Canada, at the time they are manufactured.

Crankcase Emissions Control System

Your vehicle has a positive crankcase ventilation system. This keeps gasses that build up in the engine's crankcase from going into the atmosphere. The positive crankcase ventilation valve routes them from the crankcase back to the

intake manifold. They are then drawn into the engine and burned.

Evaporative Emissions Control System

As gasoline evaporates in the fuel tank, an evaporative emissions control canister filled with charcoal adsorbs the vapor. It is stored in this canister while the engine is off. After the engine is started and warmed up, the vapor is drawn into the engine and burned during driving.

Onboard Refueling Vapor Recovery

The onboard refueling vapor recovery (ORVR) system captures the fuel vapors during refueling. The vapors are adsorbed in a canister filled with activated carbon. While driving, the fuel vapors are drawn into the engine and burned off.

Emissions Controls

Exhaust Emissions Controls

The exhaust emissions controls include three or four systems: PGM-FI, ignition timing control, exhaust gas recirculation (DX, DX-G, LX, SE, EX and EX-L), and three way catalytic converter. These systems work together to control the engine's combustion and minimize the amount of HC, CO, and NOx that comes out the tailpipe. The exhaust emissions control systems are separate from the crankcase and evaporative emissions control systems.

PGM-FI System

The PGM-FI system uses sequential multiport fuel injection. It has three subsystems: air intake, engine control, and fuel control. The powertrain control module (PCM) in automatic transmission vehicles or the engine control module (ECM) in manual transmission vehicles uses various sensors to determine how

much air is going into the engine. It then controls how much fuel to inject under all operating conditions.

Ignition Timing Control System

This system constantly adjusts the ignition timing, reducing the amount of HC, CO, and NOx produced.

Exhaust Gas Recirculation (EGR) System

On DX, DX-G, LX, SE, EX and EX-L models

The exhaust gas recirculation (EGR) system takes some of the exhaust gas and routes it back into the intake manifold. Adding exhaust gas to the air/fuel mixture reduces the amount of NOx produced when the fuel is burned.

Three Way Catalytic Converter

The three way catalytic converter is in the exhaust system. Through chemical reactions, it converts HC, CO, and NOx in the engine's exhaust to carbon dioxide (CO₂), nitrogen (N₂), and water vapor.

Replacement Parts

The emissions control systems are designed and certified to work together in reducing emissions to levels that comply with the Clean Air Act. To make sure the emissions remain low, you should use only new Honda replacement parts or their equivalent for repairs. Using lower quality parts may increase the emissions from your vehicle.

The emissions control systems are covered by warranties separate from the rest of your vehicle. Read your warranty manual for more information.

Three Way Catalytic Converter

DX, DX-G, LX, SE, EX, EX-L

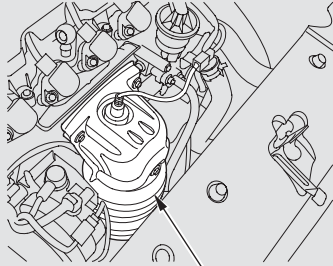

THREE WAY CATALYTIC CONVERTER

The three way catalytic converter contains precious metals that serve as catalysts, promoting chemical reactions to convert the exhaust gasses without affecting the metals. The catalytic converter is referred to as a three-way catalyst, since it acts on HC, CO, and NOx. A replacement unit must be an original Honda part or its equivalent.

The three way catalytic converter must operate at a high temperature

Si model

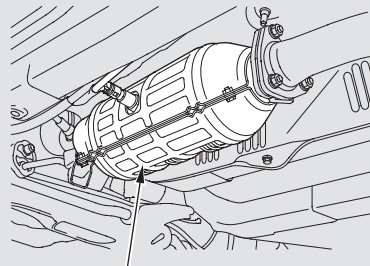

THREE WAY CATALYTIC CONVERTER

for the chemical reactions to take place. It can set on fire any combustible materials that come near it. Park your vehicle away from high grass, dry leaves, or other flammables.

A defective three way catalytic converter contributes to air pollution, and can impair your engine's performance. Follow these guidelines to protect your vehicle's three way catalytic converter.

- Always use unleaded gasoline. Even a small amount of leaded gasoline can contaminate the catalyst metals, making the three way catalytic converter ineffective.
- Keep the engine well maintained.
- Have your vehicle diagnosed and repaired if it is misfiring, back-firing, stalling, or otherwise not running properly.

Emissions Testing

Testing of Readiness Codes

If you take your vehicle for an emissions test shortly after the battery has been disconnected or gone dead, it may not pass the test. This is because of certain “readiness codes” that must be set in the on-board diagnostics for the emissions systems. These codes are erased when the battery is disconnected, and set again only after several days of driving under a variety of conditions.

If the testing facility determines that the readiness codes are not set, you will be requested to return at a later date to complete the test. If you must get the vehicle retested within the next two or three days, you can condition the vehicle for retesting by doing the following.

1. Make sure the gas tank is nearly, but not completely, full (around 3/4).
2. Make sure the vehicle has been parked with the engine off for 6 hours or more.
3. Make sure the ambient temperature is between 40° and 95°F (4° and 35°C).
4. Without touching the accelerator pedal, start the engine, and let it idle for 20 seconds.
5. Keep the vehicle in Park (automatic transmission) or neutral (manual transmission). Increase the engine speed to 2,000 rpm, and hold it there until the temperature gauge rises to at least 1/4 of the scale (about 3 minutes).
6. Without touching the accelerator pedal, let the engine idle for 20 seconds.

7. Select a nearby lightly traveled major highway where you can maintain a speed of 50 to 60 mph (80 to 97 km/h) for at least 20 minutes. Drive on the highway in D (automatic) or 5th (manual). Do not use the cruise control. When traffic allows, drive for 90 seconds without moving the accelerator pedal. (Vehicle speed may vary slightly; this is okay.) If you cannot do this for a continuous 90 seconds because of traffic conditions, drive for at least 30 seconds, then repeat it two more times (for a total of 90 seconds).
8. Then drive in city/suburban traffic for at least 10 minutes. When traffic conditions allow, let the vehicle coast for several seconds without using the accelerator pedal or the brake pedal.
9. Make sure the vehicle has been parked with the engine off for 30 minutes.

If the testing facility determines the readiness codes are still not set, see your dealer.

Warranty and Customer Relations

Customer Service Information.....	380
Warranty Coverages	381
Reporting Safety Defects.....	382
Authorized Manuals.....	383

Customer Service Information

Honda dealership personnel are trained professionals. They should be able to answer all your questions. If you encounter a problem that your dealership does not solve to your satisfaction, please discuss it with the dealership's management. The service manager or general manager can help. Almost all problems are solved in this way.

If you are dissatisfied with the decision made by the dealership's management, contact Honda Customer Service.

U.S. Owners:

American Honda Motor Co., Inc.
Automobile Customer Service
Mail Stop 500-2N-7A
1919 Torrance Boulevard
Torrance, California 90501-2746

Tel: (800) 999-1009

Canadian Owners:

Honda Canada Inc.
Customer Relations
180 Honda Boulevard
Markham, ON
L6C 0H9

Tel: 1-888-9-HONDA-9

Fax: 1-877-939-0909

E-Mail: ch_honda_cr@ch.honda.com

In Puerto Rico and the U.S. Virgin Islands:

Bella International
P.O. Box 190816
San Juan, PR 00919-0816

Tel: (787) 620-7546

When you call or write, please give us this information:

- Vehicle Identification Number (see page 362)
- Name and address of the dealer who services your vehicle
- Date of purchase
- Odometer reading of your vehicle
- Your name, address, and telephone number
- A detailed description of the problem
- Name of the dealer who sold the vehicle to you

U.S. Owners

Your new vehicle is covered by these warranties:

New Vehicle Limited Warranty — covers your new vehicle, except for the emissions control systems and accessories, against defects in materials and workmanship.

Emissions Control Systems Defects Warranty and Emissions Performance Warranty — these two warranties cover your vehicle's emissions control systems. Time, mileage, and coverage are conditional. Please read your warranty booklet for exact information.

Seat Belt Limited Warranty — a seat belt that fails to function properly is covered by a limited warranty. Please read your warranty booklet for details.

Rust Perforation Limited Warranty — all exterior body panels are covered for rust-through from the inside for the specified time period with no mileage limit.

Accessory Limited Warranty — Honda accessories are covered under this warranty. Time and mileage limits depend on the type of accessory and other factors. Please read your warranty booklet for details.

Replacement Parts Limited Warranty — covers all Honda replacement parts against defects in materials and workmanship.

Replacement Battery Limited Warranty — provides prorated coverage for a replacement battery purchased from your dealer.

Replacement Muffler Lifetime Limited Warranty — provides coverage for as long as the purchaser of the muffler owns the vehicle.

Restrictions and exclusions apply to all these warranties. Please read the 2011 Honda warranty information booklet that came with your vehicle for precise information on warranty coverages. Your vehicle's original tires are covered by their manufacturer. Tire warranty information is in a separate booklet.

Canadian Owners

Please refer to the 2011 warranty manual that came with your vehicle.

Reporting Safety Defects

In the US

If you believe that your vehicle has a defect which could cause a crash or could cause injury or death, you should immediately inform the National Highway Traffic Safety Administration (NHTSA), in addition to notifying American Honda Motor Co., Inc.

If NHTSA receives similar complaints, it may open an investigation, and if it finds that a safety defect exists in a group of vehicles, it may order a recall and remedy campaign. However, NHTSA cannot become involved in individual problems between you, your dealer, or American Honda Motor Co., Inc.

To contact NHTSA, you may call the Vehicle Safety Hotline toll-free at 1-888-327-4236 (TTY: 1-800-424-9153); go to <http://www.safercar.gov>; or write to: Administrator, NHTSA, 1200 New Jersey Avenue, SE., Washington, DC 20590.

You can also obtain other information about motor vehicle safety from <http://www.safercar.gov>.

In Canada

If you believe that your vehicle has a defect which could cause a crash or could cause injury or death, you should immediately inform Honda Canada Inc. and you may also inform Transport Canada.

If Transport Canada receives similar complaints, it may open an investigation, and if it finds that a safety defect exists in a group of vehicles, it may lead to a recall and remedy campaign. However, Transport Canada cannot become involved in individual problems between you, your dealer, or Honda Canada Inc.

To contact Transport Canada's Defect Investigations and Recalls Division, you may call 1-800-333-0510. For more information on reporting safety defects or about motor vehicle safety, go to <http://www.tc.gc.ca/roadsafety>.

Purchasing Factory Authorized Manuals (U.S. only)

The publications shown below can be purchased from Helm Incorporated. You can order by phone or online:

- Call Helm Inc. at 1-800-782-4356 (credit card orders only)
- Go online at www.helminc.com

If you are interested in other years or models, contact Helm Inc. at 1-800-782-4356.

Publication Form Number	Form Description
61SNA0C	2011 Honda Civic 2/4 door Service Manual
61SNA0CEL	2006-2011 Honda Civic 2/4 door Electrical Troubleshooting Manual
61SNA30	2006-2011 Model Series Honda Civic 2/4 door Body Repair Manual
31SVA650	2011 Honda Civic 2-door Owner's Manual
31SNA840	2011 Honda Civic Navigation System Manual
31SNAM50	2011 Honda Civic Honda Service History
31SVAQ50	2011 Honda Civic 2-door Technology Reference Guide
HON-R	Order Form for Previous Years Indicate Year and Model Desired

Service Manual:

Covers maintenance and recommended procedures for repair to engine and chassis components. It is written for the journeyman mechanic, but it is simple enough for most mechanically inclined owners to understand.

Electrical Troubleshooting Manual:

Complements the Service Manual by providing in-depth troubleshooting information for each electrical circuit in your vehicle.

Body Repair Manual:

Describes the procedures involved in the replacement of damaged body parts.

A			
AAC.....	152, 205	Automatic Transmission.....	274
Accessories and Modifications	261	Capacity, Fluid	365
ACCESSORY (Ignition Key		Checking Fluid Level	308
Position)	81	Shifting.....	274
Accessory Power Sockets.....	112	Shift Lever Position	
Active Head Restraints	100	Indicators.....	274
Adding Engine Coolant.....	304	Shift Lever Positions	275
Additives, Engine Oil.....	301	Shift Lock Release.....	277
Airbag (SRS)	9, 21		
Airbag System Components.....	21	B	
Air Conditioning System.....	118	Battery	
Usage	121	Charging System	
Air Pressure, Tires	323, 325, 366	Indicator.....	59, 349
Antifreeze	304	Jump Starting	345
Anti-lock Brakes (ABS)		Maintenance.....	333
Indicator.....	61, 280	Specifications	366
Operation	280	Before Driving	251
Anti-theft, Audio System.....	221	Belts, Seat	8, 18
Anti-theft Steering Column		Beverage Holders.....	111
Lock.....	81	<i>Bluetooth</i> [®] HandsFreeLink [®]	227
Audio System	123	Booster Seats	49
Auto Door Locking/Unlocking.....	84	Brakes	
Automatic Seat Belt Tensioners	19	Anti-lock System (ABS)	280
Automatic Speed Control.....	224	Break-in, New Linings	252
		Bulb Replacement	316
		Fluid	310
		Parking.....	109
		System Design	279
		System Indicator.....	60, 351
		Wear Indicators	279
		Braking System.....	279
		Break-in, New Vehicle	252
		Brightness Control, Instruments...	76
		Bulb Replacement	
		Back-up Lights	316
		Brake Lights.....	316
		Fog Lights	317
		Front Parking Lights.....	315
		Front Side Marker Lights.....	315
		Headlights	312
		High-mount Brake Light	319
		Rear Lights.....	316
		Specifications	365
		Turn Signal Lights.....	315
		Bulbs, Halogen.....	312, 317
		C	
		Capacities Chart.....	365

CONTINUED

Index

- Carbon Monoxide Hazard 52
Carrying Cargo 263
CAUTION, Explanation of iii
CD Care 216
CD Changer 139, 179
CD Changer Error Messages 141
CD Player 134, 172
Ceiling Light 114
Certification Label 362
Chains 331
Changing a Flat Tire 339
Changing Oil
 How to 302
 When to 291
Charging System Indicator ... 59, 349
Check Fuel Cap Message 70
Checklist, Before Driving 269
Child Safety 33
 Booster Seats 49
 Child Seats 40
 Important Safety
 Reminders 33, 36
 Infants 38
 Large Children 48
 LATCH 42
 Risks with Airbags 34
 Small Children 39
 Tether 46
 Warning Labels 53
 Where Should a Child Sit? 34
Child Seats
 Installing 41
 LATCH 42
 Selecting 40
 Tether Anchorage Points 46
Cleaning
 Seat Belts 319
Clock 222
Clutch Fluid 311
CO in the Exhaust 373
Coat Hook 112
Cold Weather, Starting in 270
Compact Spare Tire 338
Console Compartment 111
Consumer Information 380
Controls, Instruments and 55
Coolant
 Adding 304
 Checking 257
 Proper Solution 304
 Temperature Gauge 70
Crankcase Emissions Control
 System 373
Cruise Control Indicator 64
Cruise Control Operation 224
Cup Holders 111
Customer Service Information 380
- D**
- DANGER, Explanation of iii
Dashboard 3, 56
Daytime Running Lights 75
Daytime Running Lights
 Indicator 65
Dead Battery 345
Defects, Reporting Safety 382
Defogger, Rear Window 77
Defrosting the Windows 122
Dimensions 364
Dimming the Headlights 74
Dipstick
 Automatic Transmission 308
 Engine Oil 255
Directional Signals 74
Disc Brake Wear Indicators 279
Disc Care 216

Disc Player	134, 172
Display Change Button	68
Disposal of Used Oil	304
Doors	
Auto Door Locking/Unlocking..	84
Locking and Unlocking	82
Power Door Locks	83
DOT Tire Quality Grading*	367
Downshifting, Manual	
Transmission	271
Driver and Passenger Safety	5
Driving	267
Economy	258
Dust and Pollen Filter	321

E

Economy, Fuel	258
Electric Power Steering (EPS)	
Indicator	62
Electronic Stability Control (ESC)	
System	282
Emergencies	337
Battery, Jump Starting	345
Brake System Indicator	351
Changing a Flat Tire	339

Charging System Indicator	349
Checking the Fuses	352
Hazard Warning Flashers	77
Jump Starting	345
Low Oil Pressure Indicator	349
Malfunction Indicator Lamp	350
Overheated Engine	347
Towing	358
Emergency Brake	109
Emergency Flashers	77
Emergency Towing	358
Emergency Trunk Opener	94
Emissions Controls	373
Emissions Testing	376
Engine	
Adding Engine Coolant	304
Coolant Temperature Gauge	70
If It Won't Start	343
Malfunction Indicator	
Lamp	59, 350
Oil Life Indicator	291
Oil Pressure Indicator	59, 349
Oil, Synthetic	301
Oil, What Kind to Use	300
Overheating	347
Specifications	364

Speed Limiter	273, 276
Starting	270
Ethanol in Gasoline	253
Evaporative Emissions Controls..	373
Exhaust Fumes	52
Expectant Mothers, Use of Seat	
Belts by	16

F

Fan Control	119
Features	117
Filling the Fuel Tank	253
Filters	
Dust and Pollen	321
Oil	302
Flashers, Hazard Warning	77
Flat Tire, Changing a	339
Floor Mats	320

CONTINUED

Index

Fluids	
Automatic Transmission.....	308
Brake.....	310
Clutch.....	311
Manual Transmission	309
Power Steering.....	311
Windshield Washer	307
Fog Lights.....	75
FM Stereo Radio	
Reception	214
Folding Rear Seat	101
Four-way Flashers	77
Front Airbags.....	9, 23
Front Seat	
Adjusting.....	95
Airbags.....	9, 23
Fuel.....	252
Check Fuel Cap Message.....	70
Economy	258
Fill Door and Cap.....	253
Gauge	70
Low Fuel Indicator	66
Octane Requirement	252
Oxygenated	253
Tank, Refueling	253
Fuel Economy	258

Fuse Locations.....	356
Fuses, Checking the.....	352

G

Gas Mileage, Improving.....	258
Gasoline	252
Gauge	70
Low Fuel Indicator	66
Octane Requirement	252
Tank, Refueling	253
Gas Station Procedures.....	253
Gauges	
Engine Coolant Temperature ...	70
Fuel.....	70
Gearshift Lever Positions	
Automatic Transmission.....	274
Manual Transmission	272
Glove Box	111
Gross Axle Weight Rating	
(GAWR)	265
Gross Vehicle Weight Rating	
(GVWR)	265

H

Halogen Headlight Bulbs.....	312
HandsFreeLink®	227
Hazard Warning Flashers.....	77
Headlights	
Aiming.....	312
Daytime Running Lights.....	75
High Beam Indicator	65
Lights On Indicator	65
Reminder Chime.....	74
Replacing Halogen Bulbs	312
Turning on	74
Head Restraints	98
Heated Mirrors	109
Heaters, Seat	103
Heating and Cooling.....	118
High Altitude, Starting at.....	270
High Beam.....	74
High-mount Brake Light.....	319
Hood, Opening and Closing the...	254
Horn.....	4, 72
Hydraulic Clutch.....	311

I	
Identification Number, Vehicle....	362
Ignition	
Keys.....	79
Switch.....	81
Timing Control System.....	374
Immobilizer System.....	80
Important Safety Precautions	6
Indicators	
ABS (Anti-Lock Brake).....	61
Brake (Parking and Brake System)	60, 351
Charging System.....	59, 349
Cruise Control.....	64
Door Open	65
DRL (Daytime Running Lights).....	65
EPS (Electric Power Steering) ..	62
Fog Light	65
High Beam.....	65
Key (Immobilizer System)	61
Lights On	65
Low Fuel.....	66
Low Oil Pressure.....	59, 349
Low Tire Pressure.....	63, 284

Maintenance Minder™.....	62, 291
Malfunction Indicator Lamp	350
REV Limit	63
Security System	66
Seat Belt.....	59
Side Airbag Off	60
SRS	60
TPMS	63, 285
Trunk Open	65
Turn Signal and Hazard Warning	61
VSA Activation	64
VSA System.....	64
Washer Level	65
Indicators, Instrument Panel.....	57, 59
Infant Restraint	38
Infant Seats	
Installing	41
Tether Anchor Points	46
Inflation, Proper Tire	323
Information Display.....	67
Inside Mirror	108
Inspection, Tire	326
Installing a Child Seat	41
Tether Anchorage Points	46

Using LATCH	42
Instrument Panel	3, 56
Instrument Panel Brightness	76
Instrument and Controls.....	55
Interior Lights	114
Introduction	i
iPod®	142, 194

J

Jacking up the Vehicle	340
Jack, Tire	339
Jump Starting	345

K

Keys.....	79
-----------	----

L

Label, Certification	362
Lane Change, Signaling	74
Lap/Shoulder Belts	14, 19
LATCH System.....	42

CONTINUED

Index

Lights			
Bulb Replacement	312	Owner's Maintenance	
Indicators	57, 59	Checks	296
Parking	74	Safety	290
Turn Signal	74	Malfunction Indicator Lamp ..	59, 350
Load Limits	264	Manual Transmission	271
LOCK (Ignition Key Position)	81	Checking Fluid Level	309
Locks		Shifting	271
Anti-theft Steering Column	81	Manual Transmission Fluid	309
Fuel Fill Door	253	Mats, Floor	320
Power Door	83	Meters, Gauges	67
Trunk	93	Mirrors, Adjusting	108
Low Coolant Level	257	Modifying Your Vehicle	262
Low Fuel Indicator	66	Moonroof	106
Low Oil Pressure Indicator	59, 349	MP3	135, 152, 173, 182, 205
Lower Anchors	42		
Lower Gear, Downshifting to a....	271	N	
Lubricant Specifications Chart	365	Neutral Gear Position	275
Luggage, Storing (Cargo)	263	New Vehicle Break-in	252
		Normal Shift Speeds	272
M		NOTICE, Explanation of	i
Maintenance	289	Numbers, Identification	362
Items	294, 297		
Minder	291	O	
Minder Indicator	62, 291	Octane Requirement, Gasoline	252
		Odometer	68
		Odometer, Trip	68
		Oil	
		Change, How to	302
		Change, When to	291
		Checking Engine	255
		Pressure Indicator	59, 349
		Selecting Proper Viscosity	
		Chart	301
		ON (Ignition Key Position)	81
		Onboard Refueling Vapor	
		Recovery	373
		Outside Mirrors	108
		Outside Temperature	69
		Overheating, Engine	347
		Owner's Maintenance Checks	296
		Oxygenated Fuels	253
		P	
		Panel Brightness Control	76
		Park Gear Position	275
		Parking	278
		Parking Brake	109
		Parking Brake and Brake	
		System Indicator	60, 351

Parking Lights 74, 316
 Parking Over Things that
 Burn..... 278, 375
 Passenger Airbag Off Indicator..... 30
 PC Card..... 181
 PC Card Error Messages..... 193
 PGM-FI System..... 374
 Pollen Filter 321
 Power Door Locks 83
 Power Socket Locations 110, 112
 Power Steering Fluid..... 311
 Power Windows 104
 Pregnancy, Using Seat Belts 16
 Preparing to Drive 269
 Protecting Adults and Teens..... 11
 Additional Safety Precautions.... 16
 Advice for Pregnant Women..... 16
 Protecting Children 33
 General Guideline..... 33
 Installing a Child Seat 41
 Protecting Infants..... 38
 Protecting Larger Children 48
 Protecting Small Children 39
 Selecting a Child Seat..... 40
 Using Child Seats with
 Tethers..... 46

Using LATCH 42

R

Radiator Overheating..... 347
 Radio/Disc Sound System..... 124
 Radio/Disc/PC Card/USB Sound
 System..... 159
 Radio, XM® 129, 163
 Recommended Tire Pressures 325
 Radio Theft Protection..... 221
 Readiness Codes..... 350, 376
 Rear Lights, Bulb
 Replacement..... 316
 Rear Seat Access 96
 Rear Seat, Folding 101
 Rearview Mirror 108
 Rear Window Defogger 77
 Reclining the Seat-backs..... 95
 Recommended Shift Speeds 272
 Refueling..... 253
 Reminder Indicators..... 57, 59
 Remote Audio Controls..... 219
 Remote Transmitter 89
 Replacement Information
 Dust and Pollen Filter 321

Engine Oil and Filter 302
 Fuses 352
 Light Bulbs 312
 Maintenance Minder™ 291
 Spark Plugs..... 364
 Tires and Wheels..... 330
 Wiper Blades..... 321
 Replacing Seat Belts After a
 Crash 20
 Reporting Safety Defects..... 382
 Reserve Tank, Engine
 Coolant..... 257, 304
 Restraint, Child 33
 Reverse Gear Position..... 275
 Reverse Lockout..... 273
 Rotation, Tire 328

S

Safety Belts..... 8, 18
 Safety Defects, Reporting..... 382
 Safety Features 7
 Airbags..... 9
 Seat Belts 8

CONTINUED

Index

Safety Labels, Location of	53	Setting the Clock	222	How the Passenger Airbag	
Safety Messages	iii	Shift Lever Position Indicators ...	274	Off Indicator Works	30
Seat Belts	8, 18	Shift Lock Release	277	How the Side Airbag Off	
Additional Information	18	Side Airbags	9, 27	Indicator Works	30
Automatic Seat Belt		Off Indicator	30, 60	How the SRS Indicator Works ...	29
Tensioners	19	Side Curtain Airbags	9, 29	How Your Front Airbags	
Cleaning	319	Side Marker Lights, Bulb		Work	23
Lap/Shoulder Belt	14, 19	Replacement	316	How Your Side Airbags Work ...	27
Maintenance	20	Signaling Turns	74	How Your Side Curtain Airbags	
Reminder Indicator and		Snow Chains	331	Work	29
Beeper	18, 59	Snow Tires	331	SRS Indicator	29, 60
System Components	18	Sockets, Accessory Power	112	START (Ignition Key Position)	81
Use During Pregnancy	16	Sound System	123	Starting the Engine	270
Wearing a Lap/Shoulder		Spare Tire		In Cold Weather at High	
Belt	14, 19	Inflating	338	Altitude	270
Seating Capacities	364	Specifications	366	With a Dead Battery	345
Seats	95	Spark Plugs	364	Steam Coming from Engine	347
Adjusting	95	Specifications	364	Steering Wheel	
Folding	101	Speed Control	224	Adjustments	78
Heaters	103	Speed Limiter	273, 276	Anti-theft Column Lock	81
Security System	223	Spotlights	115	Steering Wheel	
Selecting a Child Seat	40	SRS, Additional Information	21	Buttons	219, 224, 227
Serial Number	362	Additional Safety Precautions ...	32	Stereo Sound System	123
Service Intervals	291	Airbag Service	31	Storing Your Vehicle	335
Service Manual*	383	Airbag System Components	21		
Service Station Procedures	253				

Supplemental Restraint System.....	9, 21
Servicing	31
SRS Indicator.....	29, 60
System Components.....	21
SVC (Speed-sensitive Volume Compensation).....	128, 171
Synthetic Oil.....	301

T

Taking Care of the Unexpected ..	337
Technical Descriptions	
DOT Tire Quality Grading*	367
Emissions Control Systems.....	373
Three Way Catalytic Converter.....	374, 375
Temperature Gauge	70
Tether Anchor Points.....	46
Theft Protection, Radio.....	221
Three Way Catalytic Converter.....	374, 375
Time, Setting the	222
Tire Chains	331
Tire, How to Change a Flat	339

Tire Pressure Monitoring System (TPMS)	284
Tires	323
Air Pressure	323, 325
Chains	331
Checking Wear	326
Compact Spare	338
DOT Tire Quality Grading	367
Glossary of Tire Terminology..	370
Inflation.....	323
Inspection	326
Labeling	369
Low Tire Pressure Indicator.....	63, 284
Maintenance.....	327
Replacing	329
Rotating.....	328
Service Life.....	327
Snow	331
Specifications	366
Summer Tires	325, 330
TPMS	284
Wear	328
Wheels	332
Tools, Tire Changing	339

Towing	
A Trailer.....	287
Emergency Wrecker	358
Transmission	
Checking Fluid Level, Automatic	308
Checking Fluid Level, Manual	309
Fluid Selection	308, 309
Identification Number.....	363
Shifting the Automatic.....	274
Shifting the Manual.....	271
Treadwear*	367
Treadwear Indicators.....	326
Trip Meter	68
Trunk.....	93
Emergency Opener	94
Opening.....	93
Open Indicator	65
Turn Signals	74

CONTINUED

Index

U

- Unexpected, Taking Care
of the 337
- Uniform Tire Quality Grading* ... 367
- Unleaded Gasoline..... 252
- USB Adapter
Cable 144, 153, 196, 207
- USB Flash Memory Device.. 151, 204
- Used Oil, How to Dispose of 304

V

- Vanity Mirror 113
- Vehicle Capacity Load 264
- Vehicle Dimensions..... 364
- Vehicle Identification Number..... 362
- Vehicle Stability Assist (VSA®)
System..... 282
- VSA Activation Indicator 64, 282
- VSA Off Switch 283
- VSA System Indicator 64, 282
- Vehicle Storage 335
- Ventilation 120
- VIN 362
- Viscosity, Oil..... 301

W

- WARNING, Explanation of iii
- Warning Button, Hazard..... 77
- Warning Labels, Location of 53
- Warranty Coverages 381
- Washer, Windshield
Checking the Fluid Level 307
- Indicator..... 65
- Operation 73
- Wheels
Adjusting the Steering 78
- Alignment and Balance..... 327
- Compact Spare 338
- Replacing 329
- Wrench, Nut..... 340
- Windows
Auto Reverse..... 105
- Operating the Power 104
- Rear, Defogger 77
- Windshield
Cleaning 73
- Defroster 122
- Washers 73
- Wipers, Windshield
Changing Blades..... 321

- Operation 73
- WMA..... 135, 152, 173, 182, 205
- Worn Tires 326
- Wrecker, Emergency Towing..... 358

X

- XM® Radio 129, 163

* : U.S. only

Service Information Summary

Gasoline:

DX, DX-G, LX, SE, EX, EX-L:

Unleaded gasoline, pump octane number of 87 or higher.

Si:

Premium unleaded gasoline, pump octane number of 91 or higher recommended (see "Fuel Recommendations" on page 252).

Fuel Tank Capacity:

13.2 US gal (50 ℓ)

Recommended Engine Oil:

DX, DX-G, LX, SE, EX, EX-L:

API Premium grade 5W-20 detergent oil (see page 301).

Oil change capacity (including filter):

3.9 US qt (3.7 ℓ)

Si:

API Premium grade 5W-30 detergent oil (see page 301).

Oil change capacity (including filter):

4.6 US qt (4.4 ℓ)

Automatic Transmission Fluid:

Honda ATF DW-1 (automatic transmission fluid) (see page 308).

Manual Transmission Fluid:

Honda Manual Transmission Fluid preferred, or an SAE 10W-30 or 10W-40 motor oil as a temporary replacement (see page 309).

Capacity (including differential):

DX, DX-G, LX, SE, EX, EX-L:

1.5 US qt (1.4 ℓ)

Si:

1.6 US qt (1.5 ℓ)

Power Steering Fluid:

All models except Si and Canadian DX-G (M/T):

Honda Power Steering Fluid preferred, or another brand of power steering fluid as a temporary replacement. Do not use ATF (see page 311).

Brake Fluid:

Honda Heavy Duty Brake Fluid DOT 3 preferred, or a DOT 3 or DOT 4 brake fluid as a temporary replacement (see page 310).

Tire Pressure (measured cold):

DX, DX-G

Front/Rear:

32 psi (220 kPa , 2.2 kgf/cm²)

LX, SE, EX, EX-L

Front/Rear:

32 psi (220 kPa , 2.2 kgf/cm²)

Si

Front/Rear:

32 psi (220 kPa , 2.2 kgf/cm²)

Spare Tire:

60 psi (420 kPa , 4.2 kgf/cm²)