

FOREWORD

Dear Customer,

Thank you for selecting your new Kia vehicle.

As a global car manufacturer focused on building high-quality vehicles with exceptional value, Kia is dedicated to providing you with a customer service experience that exceeds your expectations.

This Owner's Manual is valid for all variants of your model, and describes all options, features, and equipment available, along with the maintenance needs. This manual may also describe optional equipment not purchased on your vehicle, country specifications, and functions and features not available in your region. Please always keep this manual in the vehicle for your and any subsequent owner's reference.

Authorized Kia Dealerships provide factory-trained technicians, utilize recommended special service tools and supply genuine Kia replacement parts to help you maintain and service your Kia during your ownership.

All information contained in this Owner's Manual was accurate at the time of publication. As Kia continues to make improvements to its products, the company reserves the right to make changes to this manual or any of its vehicles at any time without notice and without incurring any obligations.

Please drive safely and enjoy your Kia vehicle!

© 2024 Kia Canada Inc.

All rights reserved. Reproduction by any means, electronic or mechanical, including photocopying, recording, or by any information storage and retrieval system or translation in whole or part is not permitted without written authorization from Kia Canada Inc.

Printed in Mexico

How to use this manual

We want to help you get the greatest possible driving pleasure from your Kia. Your Owner's Manual can assist you in many ways.

We strongly recommend that you read the entire manual. To minimize the chance of death or injury, you must read the **WARNING** and **CAUTION** sections in the manual.

Illustrations complement the words in this manual to best explain how to enjoy your Kia. By reading your manual, you learn about features, important safety information and driving tips under various road conditions.

The general layout of the manual is provided in the Table of Contents. Use the index when looking for a specific area or subject, it has an alphabetical listing of all information in your manual.

Chapters: This manual has nine chapters plus an index. Each chapter begins with a brief list of contents so you can tell at a glance if that chapter has the information you want.

You will find various **WARNINGS**, **CAUTIONS**, and **NOTICES** in this manual. These **WARNINGS** were prepared to enhance your personal safety. You should carefully read and follow **ALL** procedures and recommendations provided in these **WARNINGS**, **CAUTIONS** and **NOTICES**.

WARNING

A **WARNING** indicates a hazardous situation which, if not avoided, may result in death or serious injury.

CAUTION

A **CAUTION** indicates a hazardous situation which, if not avoided, could result in minor or moderate injury.

NOTICE

A **NOTICE** is used to address practices not related to physical injury.

Table of Contents

Introduction	①
Your vehicle at a glance	②
Safety features of your Kia	③
Features of your vehicle	④
Driving your vehicle	⑤
Driver assistance guide	⑥
What to do in an emergency	⑦
Maintenance	⑧
Specifications & Consumer information	⑨
Abbreviations	Ⓐ
Index	Ⓛ

Introduction **1**

Fuel requirements	1-2
Vehicle modifications.....	1-4
Vehicle break-in process	1-5
Risk of burns when parking or stopping vehicle	1-5
Vehicle data collection and Event Data Recorders.....	1-6

Introduction

Fuel requirements

Your new vehicle is designed to use only unleaded fuel having a pump octane number ((R+M)/2) of 87 (Research Octane Number 91) or higher. (Do not use methanol blended fuels.)

Your new vehicle is designed to obtain maximum performance with UNLEADED FUEL, as well as minimize exhaust emissions and spark plug fouling.

Never add any fuel system cleaning agents to the fuel tank other than what has been specified. (Consult an authorized Kia dealer for details.)

- Tighten the cap until it clicks one time, otherwise the Check Engine light will appear.

WARNING

Refueling

- Do not "top off" after the nozzle automatically shuts off. Attempts to force more fuel into the tank can cause fuel overflow onto you and the ground, causing a risk of fire.
- Always check that the fuel cap is installed securely to prevent fuel spillage, especially in the event of an accident.

Gasoline containing alcohol and methanol

Gasohol, a mixture of gasoline and ethanol (also known as grain alcohol), and gasoline or gasohol containing methanol (also known as wood alcohol) are being marketed along with or instead of leaded or unleaded gasoline.

Either of these fuels may cause drivability problems and damage to the fuel system, engine control system and emission control system.

Discontinue using gasohol of any kind if drivability problems occur.

Vehicle damage or drivability problems may not be covered by the manufacturer's warranty if they result from the use of:

1. Gasoline or gasohol containing methanol.
2. Leaded fuel or leaded gasohol.
3. Gasohol containing more than 15% ethanol.

"E85" fuel is an alternative fuel comprised of 85% ethanol and 15% gasoline and is manufactured exclusively for use in Flexible Fuel Vehicles. "E85" is not compatible with your vehicle. Use of "E85" may result in poor engine performance and damage to your vehicle's engine and fuel system. Do not use fuel with an ethanol content exceeding 15%.

NOTICE

Your New Vehicle Limited Warranty does not cover damage to the fuel system or any performance problems caused by the use of "E85" fuel.

NOTICE

Never use any fuel containing methanol. Discontinue use of any methanol con-

taining products which may inhibit proper drivability.

Other fuels

Using fuels that contain Silicone (Si), MMT (Manganese, Mn), Ferrocene (Fe), and Other metallic additives, may cause vehicle and engine damage or cause misfiring, poor acceleration, engine stalling, catalyst melting, clogging, abnormal corrosion, life cycle reduction, etc.

The Malfunction Indicator Lamp (MIL) on the cluster may appear.

* NOTICE

Damage to the fuel system or performance problems caused using these other fuels may not be covered by your New Vehicle Limited Warranty.

Use of MTBE

Kia recommends avoiding fuels containing MTBE (Methyl Tertiary Butyl Ether) over 15.0% vol. (Oxygen Content 2.7% weight) in your vehicle. Fuel containing MTBE over 15.0% vol. (Oxygen Content 2.7% weight) may reduce vehicle performance and produce vapor lock or hard starting.

* NOTICE

Your New Vehicle Limited Warranty may not cover damage to the fuel system and any performance problems that are caused by the use of fuels containing methanol or fuels containing MTBE (Methyl Tertiary Butyl Ether) over 15.0% vol. (Oxygen Content 2.7% weight.)

Gasoline containing MMT

Some gasoline contains harmful manganese-based fuel additives Such as MMT (Methylcyclopentadienyl Manganese Tricarbonyl). Kia does not recommend the use of gasoline containing MMT. This type of fuel can reduce vehicle performance and affect your emission control system. The MIL MIL may appear.

Do not use methanol

Fuels containing methanol (wood alcohol) should not be used in your vehicle. This type of fuel can reduce vehicle performance and damage components of the fuel system, engine control system and emission control system.

Fuel Additives

Kia recommends that you use good quality gasoline treated with detergent additives such as TOP TIER Detergent Gasoline, which help prevent deposit formation in the engine. These gasoline will help the engine run cleaner and enhance performance of the emission control system.

For more information on TOP TIER Detergent Gasoline, please go to the website (www.toptiergas.com) For customers who do not use TOP TIER Detergent Gasoline regularly, and have problems starting or the engine does not run smoothly, additives that you can buy separately may be added to the gasoline.

If TOP TIER Detergent Gasoline is not available, one bottle of additive should be added to the fuel tank at every 13,000 km (8,000 miles) or every engine oil change is recommended. Additives are available from your authorized Kia dealer along with information

on how to use them. Do not mix other additives.

Operation in foreign countries

If you are going to drive your vehicle in another country, be sure to:

- Observe all regulations regarding registration and insurance.
- Determine that acceptable fuel is available.

Vehicle modifications

This vehicle should not be modified.

Modification of your vehicle could affect its performance, safety or durability and may even violate governmental safety and emissions regulations.

* NOTICE

Damage or performance problems resulting from any modification may not be covered under the warranty.

⚠ CAUTION

If you use an unauthorized electronic device, it may cause the vehicle to operate abnormally, wire damage, battery discharge and fire.

For your safety, do not use unauthorized electronic devices.

Vehicle break-in process

By following a few simple precautions for the first 1,000 km (600 miles) you may increase performance, economy and life of your vehicle.

- Do not race the engine.
- While driving, avoid sudden acceleration
- Do not maintain a single engine speed for long periods of time, either fast or slow. Varying engine speeds is needed to properly break-in the engine.
- Avoid hard stops, except in emergencies, to allow the brakes to seat properly.
- Don't tow a trailer during the first 2,000 km (1,200 miles) of operation.
- Fuel economy and engine performance may vary depending on your break-in process and stabilize after 6,000 km (4,000 miles). Engines may consume more oil during the break-in period.

Risk of burns when parking or stopping vehicle

- Do not park or stop the vehicle near flammable items such as leaves, paper, oil, or tire. Such items placed near the exhaust system can become a fire hazard.
- When an engine idles at a high speed with the rear side of the vehicle touching the wall, heat of the exhaust gas can cause fire and/or discoloration. Keep enough space between the rear part of the vehicle and the wall.
- Do not touch the exhaust/catalytic systems while engine is running or right after the engine is turned off. There is a risk of burns since the systems are extremely hot.

Vehicle data collection and Event Data Recorders

This vehicle is equipped with an event data recorder (EDR). The main purpose of an EDR is to record, in certain crash or near crash-like situations, such as an air bag deployment or hitting a road obstacle, data that will assist in understanding how a vehicle's systems performed. The EDR is designed to record data related to vehicle dynamics and safety systems for a short period of time, typically 30 seconds or less. The EDR in this vehicle is designed to record such data as:

- How various systems in your vehicle were operating;
- Whether or not the driver and passenger safety belts were buckled/fastened;
- How far (if at all) the driver was depressing the accelerator and/or brake pedal; and,
- How fast the vehicle was traveling.

These data can help provide a better understanding of the circumstances in which crashes and injuries occur.

NOTE: EDR data are recorded by your vehicle only if a non-trivial crash situation occurs; no data are recorded by the EDR under normal driving conditions and no personal data (e.g., name, gender, age, and crash location) are recorded. However, other parties, such as law enforcement, could combine the EDR data with the type of personally identifying data routinely acquired during a crash investigation.

To read data recorded by an EDR, special equipment is required, and access to the vehicle or the EDR is needed. In addition to the vehicle

manufacturer, other parties, such as law enforcement, that have the special equipment, can read the information if they have access to the vehicle or the EDR.

Your vehicle at a glance

Exterior overview	2-2
Interior overview	2-6
Instrument panel overview	2-8
Engine compartment.....	2-10

Your vehicle at a glance

Exterior overview

Front view

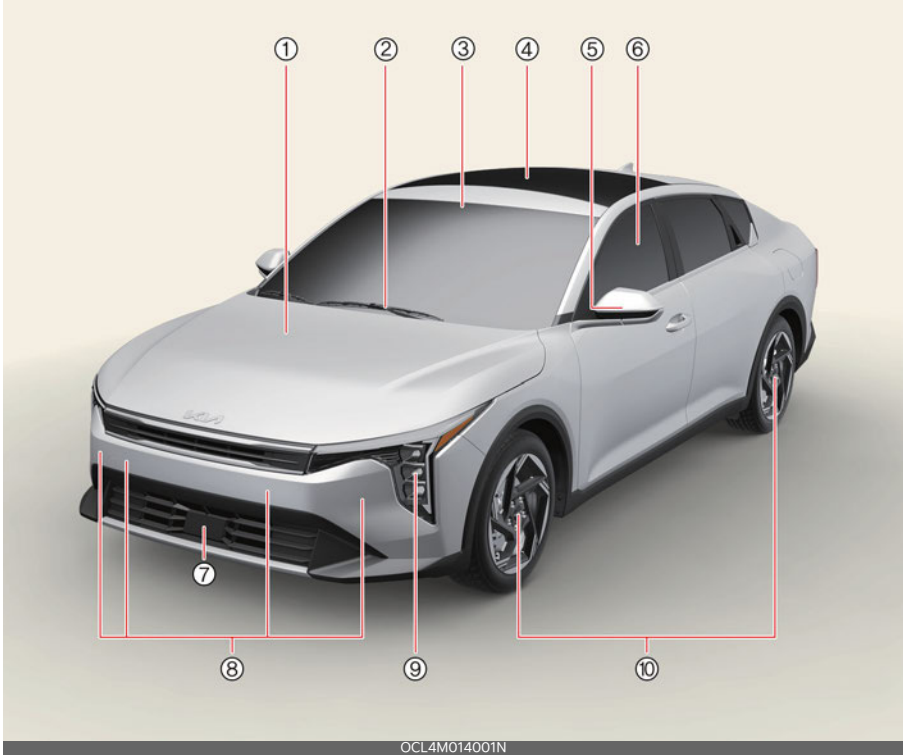

Front view (GT-Line)

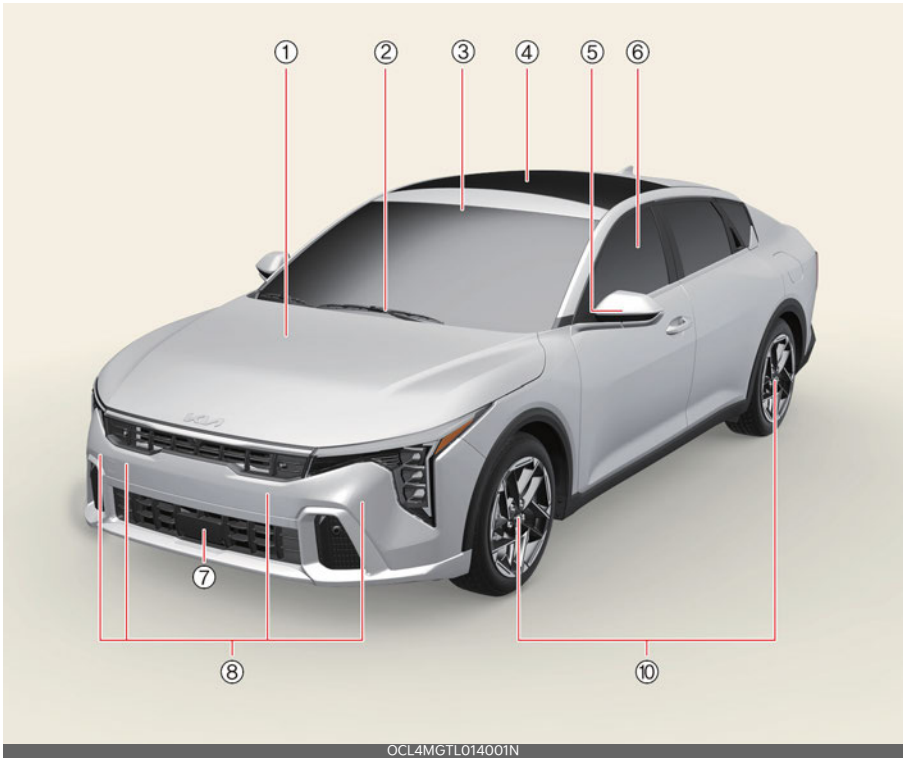

OCL4MGTLO14001N

* The actual shape may differ from the illustration.

1. Hood	4-46
2. Front windshield wiper blades	4-88, 8-24
3. Wide sunroof	4-52
4. Front view camera	6-106
5. Outside rearview mirror	4-59
6. Windows	4-42
7. Front radar	6-4, 6-57, 6-79
8. Front ultrasonic sensors	6-106
9. Head lamp	4-82, 8-50
10. Wheel and tire	8-29, 9-8

Rearview

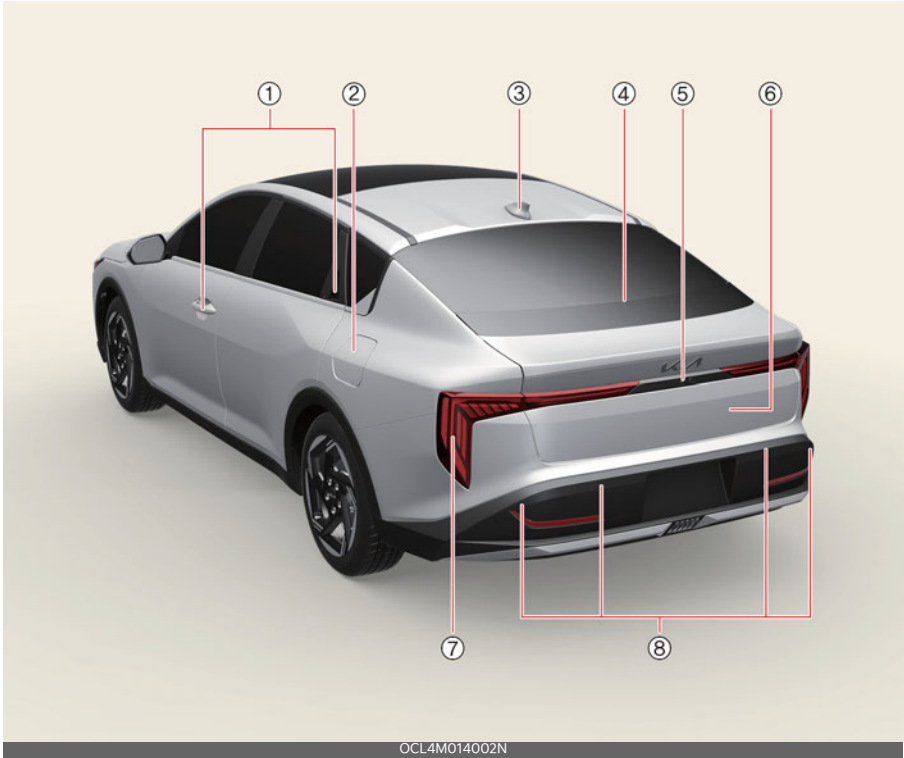

Rearview (GT-Line)

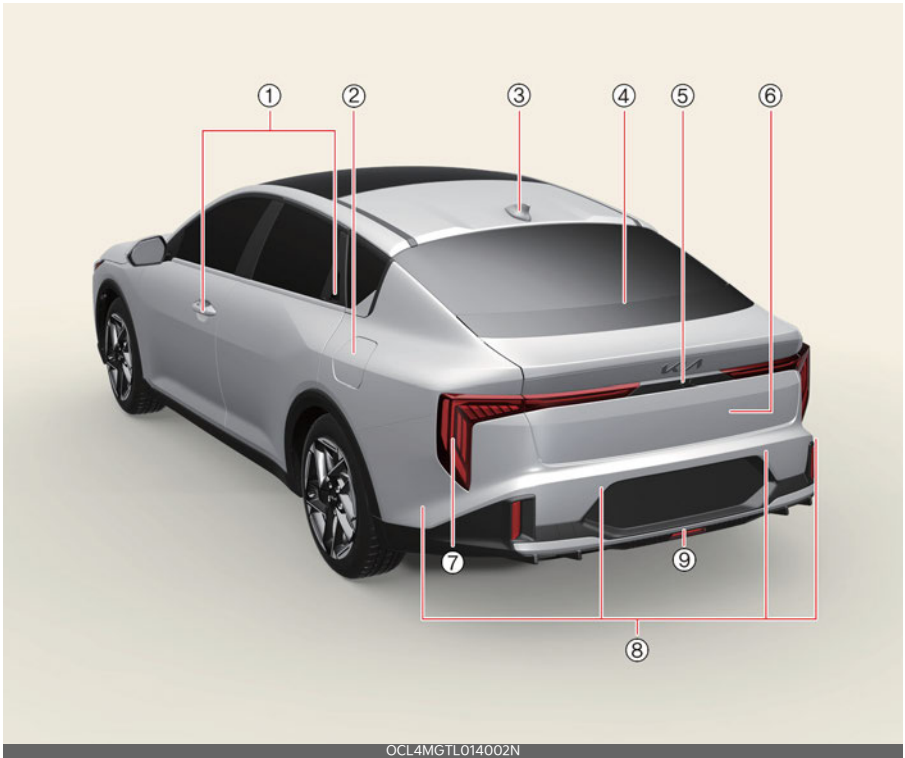

OCL4MGTL014002N

* The actual shape may differ from the illustration.

- | | |
|----------------------------|--------------|
| 1. Outside door handle | 4-17 |
| 2. Fuel filler door | 4-48 |
| 3. Antenna | 4-126 |
| 4. High mounted stop light | 8-50 |
| 5. Wide-rear view camera | 6-89, 6-93 |
| 6. Trunk | 4-36 |
| 7. Rear combination lamp | 8-50, 8-52 |
| 8. Rear ultrasonic sensors | 6-106, 6-111 |

Interior overview

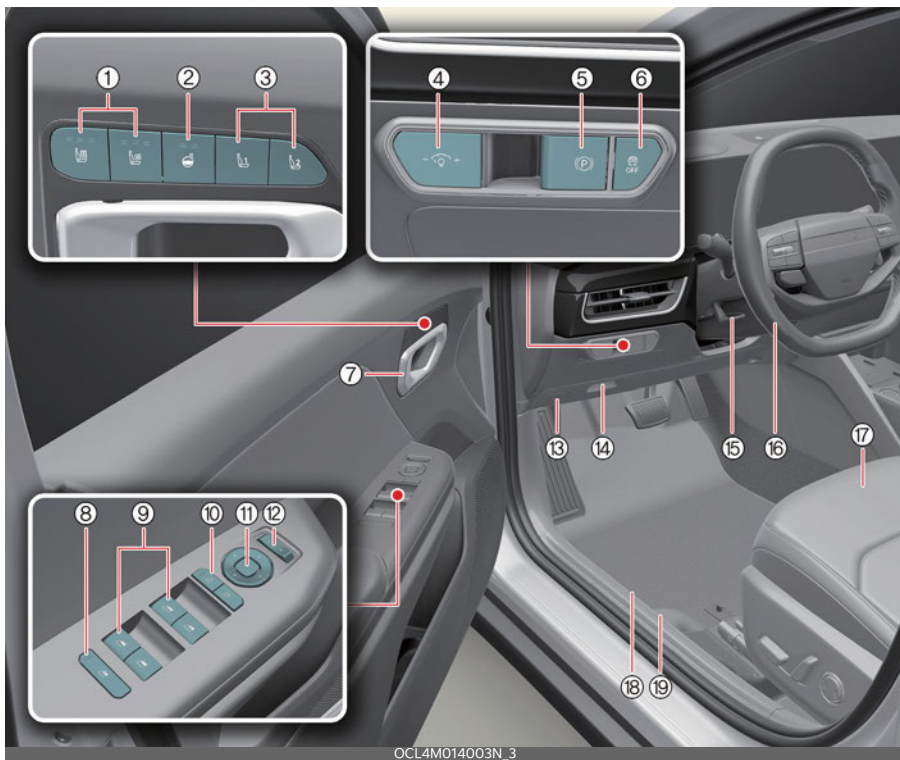

OCL4M014003N_3

* The actual shape may differ from the illustration.

1. Front seat warmer and air ventilation seat button	4-117, 4-118
2. Steering wheel heater button	4-57
3. Integrated Memory System button	4-34
4. Instrument panel illumination control switch	4-63
5. EPB switch	5-24
6. ESC OFF button	5-32
7. Inside door handle	4-19
8. Power window lock button	4-45
9. Power window switches	4-42
10. Central door lock/unlock button	4-20
11. Outside rearview mirror control switch	4-60
12. Outside rearview mirror L/R select button	4-60
13. Hood release lever	4-46

14.Instrument panel fuse	8-39
15.Steering wheel tilt/telescopic lever	4-56
16.Steering wheel	4-55
17.Seat	3-5
18.Trunk lid release lever	4-36, 4-37
19.Fuel filler door	4-48

Instrument panel overview

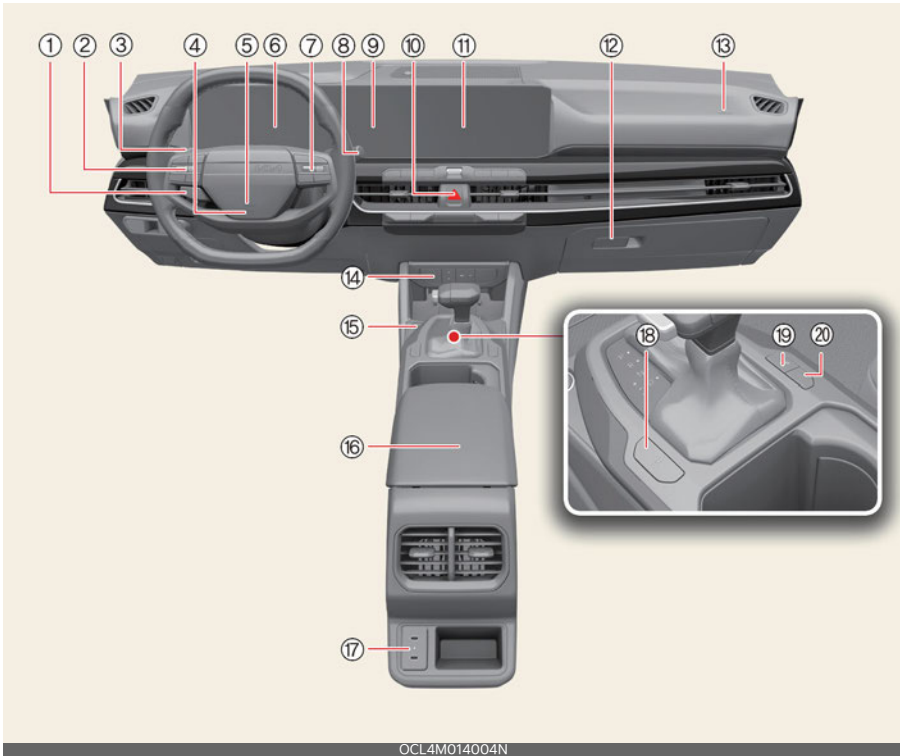

* The actual shape may differ from the illustration.

- | | |
|--|------------|
| 1. Drive mode integrated control system button | 5-37 |
| 2. Driving Assist button | 6-57, 6-75 |
| 3. Light control/Turn signals lever | 4-82 |
| 4. Horn | 4-58 |
| 5. Driver's front airbag | 3-33 |
| 6. Instrument cluster | 4-62 |
| 7. Audio remote control button | |
| 8. Wiper and washer control lever | 4-88 |
| 9. Climate control system | 4-93 |
| 10. Hazard warning flasher | 7-2 |
| 11. Infotainment system | |
| 12. Glove box | 4-115 |
| 13. Passenger's airbag | 3-33 |

14.Shift lever	5-10, 5-16
15.ENGINE START/STOP button	5-7
16.Center console storage box	4-115
17.USB charger	4-119
18.Auto Hold button	5-28
19.Parking Safety button	6-106
20.Parking/View button	6-89, 6-93

Engine compartment

Smartstream G2.0

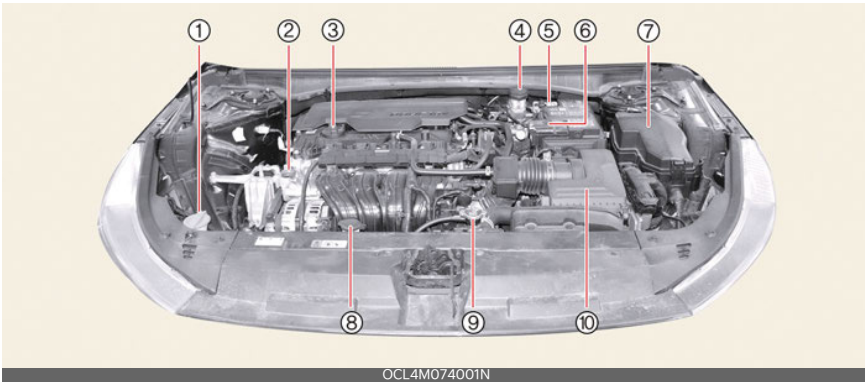

OCL4M074001N

- | | |
|--------------------------------------|------|
| 1. Windshield washer fluid reservoir | 8-21 |
| 2. Engine oil dipstick | 8-15 |
| 3. Engine oil filler cap | 8-15 |
| 4. Brake fluid reservoir | 8-19 |
| 5. Negative battery terminal | 8-26 |
| 6. Positive battery terminal | 8-26 |
| 7. Fuse box | 8-39 |
| 8. Engine coolant reservoir | 8-17 |
| 9. Radiator cap | 8-17 |
| 10. Air cleaner | 8-12 |

Smartstream G1.6 T-GDi

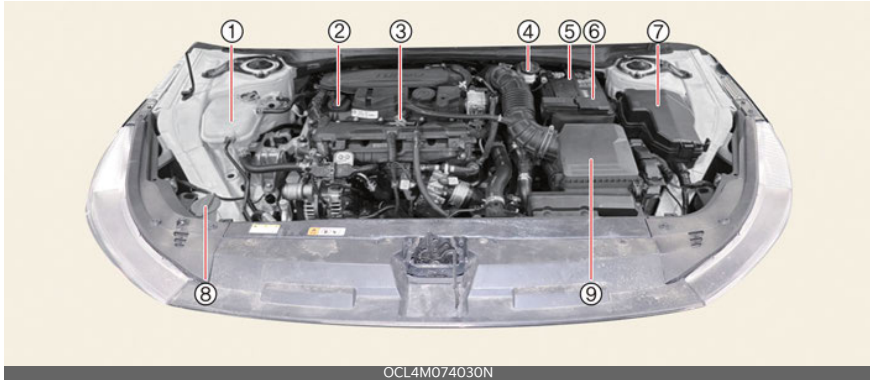

* The actual engine compartment may differ from the illustration.

1. Engine coolant reservoir	8-17
2. Brake fluid reservoir	8-19
3. Air cleaner	8-12
4. Engine oil dipstick	8-15
5. Engine oil filler cap	8-15
6. Windshield washer fluid reservoir	8-21
7. Fuse box	8-39
8. Positive battery terminal	8-26
9. Negative battery terminal	8-26

Important safety precautions	3-3
Seats.....	3-5
• Feature of Seat Leather.....	3-7
• Front seat adjustment for manual seat.....	3-8
• Front seat adjustment for power seat	3-9
• Headrest for front seat	3-11
• Seatback pocket.....	3-13
• Rear seat adjustment	3-13
Seat belts	3-16
• Seat belt restraint system.....	3-16
• Seat belt warning	3-17
• Seat belt - Driver's 3-point system with emergency locking retractor	3-18
• Seat belts - Front passenger and rear seats' 3-point system with combination locking retractor.....	3-19
• Pre-tensioner seat belt	3-21
• Seat belt precautions.....	3-22
• Care of seat belts	3-24
Child Restraint System (CRS).....	3-25
• Children always in the rear	3-25
• Selecting a CRS.....	3-26
• Installing a Child Restraint System (CRS).....	3-28
Airbag — Advanced Supplemental Restraint System	3-33
• How does the airbag system operate?.....	3-34
• Airbag warning light	3-35
• SRS components and functions	3-36
• Occupant Detection System (ODS).....	3-38
• Driver's and passenger's front airbag.....	3-43
• Side airbag	3-44
• Curtain airbag.....	3-46
• Airbag collision sensors.....	3-47

3 Safety features of your Kia

- Why didn't my airbag go off in a collision? (Inflation and non-inflation conditions of the airbag)3-48
- Supplemental Restraint System (SRS) care 3-50
- Additional safety precautions.....3-51
- Adding equipment to or modifying your air bag-equipped vehicle..... 3-52
- Airbag warning label 3-52

Safety features of your Kia

For the safety of the driver and vehicle passengers, you should become familiar with the vehicle's safety features.

Important safety precautions

You will find many safety precautions and recommendations throughout this section, and throughout this manual.

The safety precautions in this section are among the most important.

Always wear your seat belt

A seat belt is your best protection in all types of accidents. Airbags are designed to supplement seat belts, not replace them. Even though your Kia is equipped with airbags, ALWAYS make sure you and your passengers wear your seat belts, and wear them properly.

Restrain all children

All children age 13 and under should ride in your Kia properly restrained in a rear seat, not the front seat. Infants and small children should be restrained in an appropriate child restraints. Larger children should use a booster seat with the lap/shoulder belt until they can use the seat belt properly without a booster seat. Please refer to your State or Federal laws for child seating requirements.

Airbag hazards

While airbags can save lives, they can also cause serious or fatal injuries to occupants who sit too close to them, or who are not properly restrained. Infants, young children, and shorter adults are at the greatest risk of being injured by an inflating airbag. Follow all instructions and warnings in this manual.

Driver distraction

Driver distraction presents a serious and potentially deadly danger, especially for inexperienced drivers. Safety should be the first concern when behind the wheel and drivers need to be aware of the wide array of potential distractions, such as drowsiness, reaching for objects, eating, personal grooming, other passengers, and using cellular phones.

Drivers can become distracted when they take their eyes and attention off the road or their hands off the wheel to focus on activities other than driving. To reduce your risk of distraction or getting into an accident:

- ALWAYS set up your mobile devices (i.e., MP3 players, phones, navigation units, etc.) when your vehicle is parked or safely stopped.
- ONLY use your mobile device when allowed by laws and when conditions permit safe use. NEVER text or email while driving. Most countries have laws prohibiting drivers from texting. Some countries and cities also prohibit drivers from using handheld phones.
- NEVER let the use of a mobile device distract you from driving. You have a responsibility to your passengers and others on the road to always drive safely, with your hands on the wheel as well as your eyes and attention on the road.

Control your speed

Excessive speed is a major factor in crash injuries and deaths. Generally, the higher the speed, the greater the risk, but serious injuries can also occur at lower speeds. Never drive faster than is safe for current driving conditions, regardless of the maximum speed posted.

Keep your Kia in safe condition

A tire blowout or a mechanical failure can be extremely hazardous. To reduce the possibility of such problems, check your tire pressure and condition frequently, and perform all regularly scheduled maintenance.

Seats

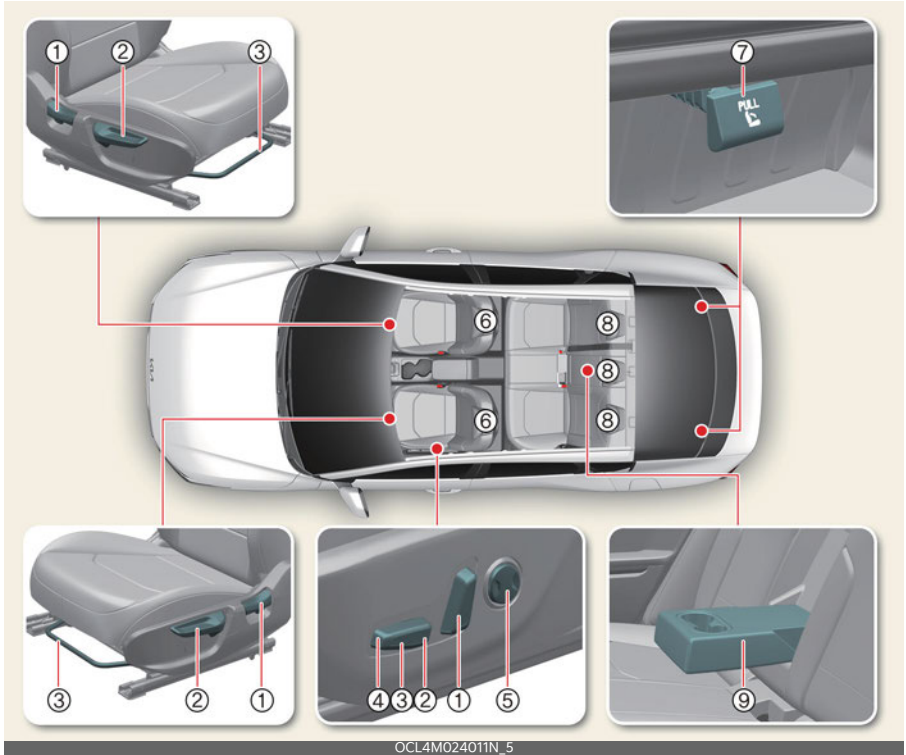

OCL4MO24011N_5

* The actual feature in the vehicle may differ from the illustration.

Front seat

- 1 Seatback angle
- 2 Seat cushion height
- 3 Forward and backward
- 4 Seat cushion tilt
- 5 Lumbar support
- 6 Headrest

Rear seat

- 7 Seatback folding
- 8 Headrest
- 9 Armrest

⚠ WARNING

Loose objects

Loose objects in the driver's foot area could interfere with the operation of the foot pedals, possibly causing an accident. Do not place anything under the front seats.

⚠ WARNING**Uprighting a seat**

Do not press the release lever on a manual seatback without holding and controlling the seatback. The seatback will spring upright, possibly impacting you or other passengers.

⚠ WARNING**Driver responsibility for passengers**

The driver must advise passengers to keep seatbacks in upright positions whenever the vehicle is in motion. If a seat is reclined during an accident, the restraint system's ability to restrain the passenger will be greatly reduced.

⚠ WARNING**Seat cushion**

Occupants should never sit on aftermarket seat cushions or sitting cushions. The passenger Occupant Detection System (ODS) may not operate properly, or the passenger's hips may slide under the lap portion of the seat belt during an accident or a sudden stop.

⚠ WARNING**Driver's seat**

- Never attempt to adjust the seat while the vehicle is moving. This could result in loss of control of your Kia.
- Do not allow anything to interfere with the normal position of the seatback.

For example, storing items against the seatback could result in serious or fatal injury in a sudden stop or collision.

- Sit as far back as possible from the steering wheel while still maintaining comfortable control of your Kia. A distance of at least 25 cm (10 inches) from your chest to the steering wheel is recommended. Failure to do so can result in airbag inflation injuries to the driver.

⚠ WARNING**Rear seatbacks**

Always lock the rear seatback before driving. Failure to do so could result in passengers or objects being thrown forward, injuring occupants.

⚠ WARNING**Unexpected seat movement**

After adjusting a manual seat, always check that it is locked by shifting your weight to the front and to the back. Sudden or unexpected movement of the driver's seat could cause you to lose control of the vehicle.

⚠ WARNING**Seat adjustment**

- Do not adjust the seat while wearing seat belts. Moving the seat forward will cause strong pressure on the abdomen.
- Do not place your hand near the seat bottom or seat track while adjusting the seat. Your hand could get caught in the seat mechanism.

⚠ WARNING**Luggage and cargo**

Do not stack/pile luggage or cargo higher than the seatback in the cargo area. In an accident the cargo could strike and injure a passenger. If objects are large, heavy or must be piled, they must be secured in the cargo area.

⚠ WARNING**Cargo area**

Do not allow passengers to ride in the cargo area under any circumstance. The cargo area is solely for the purpose of transporting luggage or cargo.

⚠ WARNING**Small objects**

Use extreme caution when picking up small objects trapped under the seats or between the seat and the center console. Your hands might be cut or injured by the sharp edges of the seats mechanism.

⚠ CAUTION**Precautions with seat covers**

Use caution when working on the seat cover. A short circuit or disconnection may occur, which could cause an abnormal noise or damage the ventilation system.

⚠ WARNING**Seat short circuit risk**

Be aware of wires or air vents when placing a seat cover or covering the seat with a plastic cover. A short circuit may occur, which could lead to fire.

Feature of Seat Leather (if equipped)

- Your car seats are upholstered with a combination of artificial and genuine leather. The genuine leather is made from the outer skin of an animal, which under goes a special process for use. Since it is a natural substance, each part differs in thickness or density. Wrinkles could appear depending on temperature and humidity.
- The seat cover is made of stretchable material to improve occupant comfort.
- The seats are curved and the side supporting area is high which provides driving comfort and stability.

⚠ CAUTION

- Belts with metallic accessories, such as zippers or keys inside the back pocket may damage the seat fabric.
- Make sure not to get the seat wet. It may change the nature of the leather.
- Jeans or clothes which could bleach may contaminate the surface of the seat covering fabric.

*** NOTICE**

Wrinkles or abrasions may appear naturally from usage. It is not a defect. Wrinkles or abrasions are not covered by warranty.

Front seat adjustment for manual seat (if equipped)

The front seat can be adjusted by using the control levers located on the outside of the seat cushion.

Moving forward and backward

Adjust the seat before driving, and make sure the seat is locked securely by trying to move forward and backward without using the lever. If the seat moves, it is not locked properly.



To move the seat forward or backward:

1. Pull the seat slide adjustment lever up and hold it.
2. Slide the seat to the position you desire.
3. Release the lever and make sure the seat is locked in place.

Reclining seatback

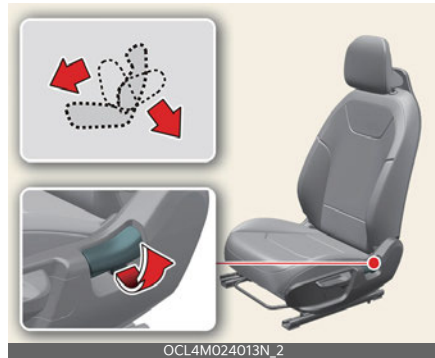

To recline the seatback:

1. Lean forward slightly and lift up the seatback recline lever.
2. Carefully lean back on the seat and adjust the seatback of the seat to the desired position.
3. Release the lever and make sure the seatback is locked in place. (The lever **MUST** return to its original position for the seatback to lock.)

⚠ WARNING

Reclining seatback

Sitting in a reclined position when the vehicle is in motion can be dangerous. Even when buckled up, the protections of the restraint system (seat belts and/or airbags) are greatly reduced by reclining the seatback.

Seat belts must be snug against an occupant's hips and chest to work properly. When the seatback is reclined, the shoulder belt cannot do its job because it will not be snug against your chest. In an accident, you could be thrown into the seat belt or slide under the seatbelt, causing neck or other injuries.

The more the seatback is reclined, the greater chance your hips will slide under

the lap belt or your neck will strike the shoulder belt.

Changing seat cushion height



To change the height of the seat cushion, push the lever up or down.

- To lower the seat cushion, push down the lever several times.
- To raise the seat cushion, pull up the lever several times.

Front seat adjustment for power seat (if equipped)

The front driver's seat can be adjusted by using the control switches located on the outside of the seat cushion.

Before driving, adjust the seat to the proper position so you can easily control the steering wheel, pedals and switches on the instrument panel.

⚠ WARNING

Unattended children

NEVER leave children unattended in a vehicle. Children might operate features of the vehicle that could injure them.

⚠ CAUTION

Power seating adjustments

- The power seating controls function by a motor. Repeated operation may cause damage to the electrical equipment.
- Do not operate two or more power seat control switches at the same time. Damage to the power seat motor or electrical components may occur.

Moving forward and backward



To move the seat forward or backward:

1. Push the control switch forward or backward to move the seat to the desired position.
2. Release the switch once the seat reaches the desired position.

Reclining seatback



To recline the seatback:

1. Push the control switch forward or backward to move the seatback to the desired angle
2. Release the switch once the seat reaches the desired position.

Changing seat cushion tilt and height

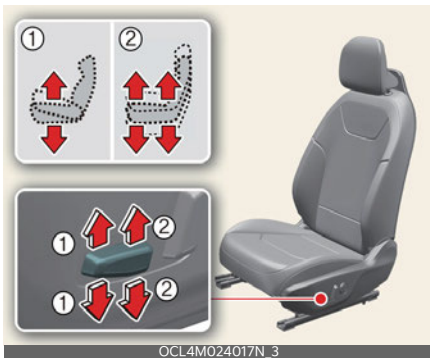

To change the tilt and height of the seat:

1. Pull the front portion (1) of the control switch up to raise or press down to lower the front part of the seat cushion.
2. Pull the rear portion (2) of the control switch up to raise or press down to

lower the back part of the seat cushion.

3. Release the switch once the seat reaches the desired position.

Adjusting lumbar support (if equipped)



The lumbar support can be adjusted by pressing the lumbar support switch on the side of the seat.

1. Press the front portion of the switch to increase support (1), or the rear portion of the switch to decrease support (2).
2. Release the switch once it reaches the desired position.

Headrest for front seat

The driver's and front passenger's seats are equipped with a headrest for safety and comfort.

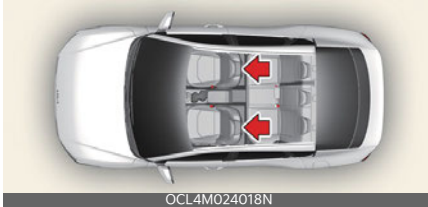

The headrest not only provides comfort for the driver and front passenger, but also helps protect the head and neck in the event of a rear collision.

For maximum effectiveness in case of an accident, the headrest should be adjusted so the middle of the headrest is as high as the center of gravity of an occupant's head. Generally, the center of gravity of most people's head is the top of their eyes.

Adjust the headrest as close to your head as possible. The use of a cushion that holds the body away from the seatback is not recommended.

⚠ WARNING

Headrest removal/adjustment

- Do not operate the vehicle with the headrests removed. Headrests can provide critical neck and head support in a crash.
- Do not adjust the headrest height while the vehicle is in motion. Driver may lose control of the vehicle.

⚠ CAUTION

Excessive pulling or pushing may damage the headrest.

Forward and rearward adjustment (if equipped)

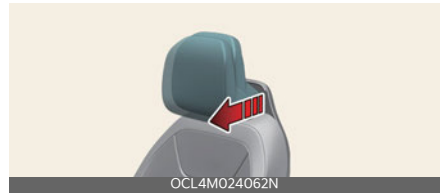

The headrest may be adjusted forward to 3 different positions by pulling the headrest forward to the desired detent. To adjust the headrest to its furthest rearwards position, pull it fully forward to the farthest position and release it.

Adjusting the height up and down



To raise the headrest:

1. Pull it up to the desired position (1).
2. To lower the headrest, push and hold the release button (2) on the headrest support.
3. Lower the headrest to the desired position (3).

*** NOTICE**

If you move the seatback forward with the headrest and seat cushion raised, the headrest may contact the sun visor or other parts of the vehicle.



⚠ WARNING

Removing headrest

NEVER allow anyone to ride in a seat with the headrest removed or reversed. Headrests can provide critical neck and head support in an accident.

Removing headrest

Type A



Reinstalling headrest

Type A



Type B



Type B



To remove the headrest:

1. Recline the seatback (2) with the reclining lever or switch (1).
2. Raise headrest to the maximum height.
3. Press the headrest release button (3) while pulling the headrest up (4).

To reinstall the headrest:

1. Put the headrest poles (2) into the holes while pressing the release button (1).
2. Recline the seatback (4) with the reclining lever or switch (3).

3. Adjust the headrest to the appropriate height.

⚠ WARNING

Headrest reinstallation

To reduce the risk of injury to the head or neck, always make sure the headrest is locked into position and adjusted properly after reinstalling.

Seatback pocket (if equipped)

The seatback pocket is located on the back of the front occupant's seatbacks.



⚠ WARNING

Seatback pockets

Do not put heavy or sharp objects in the seatback pockets. In an accident they could come loose from the pocket and injure occupants.

Rear seat adjustment

Headrest for rear seat

The rear seat is equipped with headrests in all the seating positions for the occupant's safety and comfort.

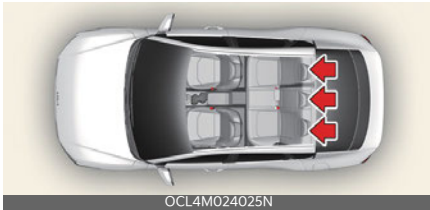

The headrest not only provides comfort, but also helps protect the head and neck in the event of a collision.

To maximize effectiveness in case of an accident, the headrest should be adjusted so the middle of the headrest is as high as the center of gravity of an occupant's head. Generally, the center of gravity of most people's heads is the height at the top of their eyes.

Adjust the headrest as close to your head as possible. The use of a cushion that holds the body away from the seatback is not recommended.

Adjusting the height up and down (if equipped)

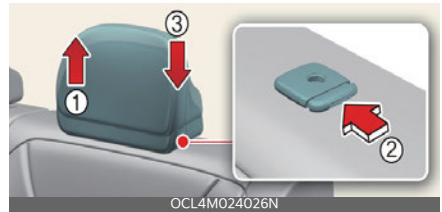

- To raise the headrest, pull it up to the desired position (1).
- To lower the headrest, push and hold the release button (2) on the headrest support and lower the headrest to the desired position (3).

Removal and reinstallation (if equipped)



- To remove the headrest, raise it to the maximum height and then press the

release button (1) while pulling the headrest upward (2).

- To reinstall the headrest, put the headrest poles (3) into the holes while pressing the release button (1).

Adjust it to the appropriate height and ensure that it locks in position.

Armrest (if equipped)

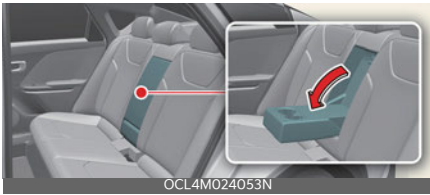

To use the armrest, pull it forward from the seatback.

Folding the rear seat (if equipped)

The rear seatbacks can be folded to facilitate carrying long items or to increase the luggage capacity of the vehicle.

* NOTICE

Folded Seatback

Do not sit on folded down seatbacks. The purpose of the fold-down rear seatbacks is to allow you to carry longer objects that could not otherwise be accommodated.

- Never allow a passenger to sit on top of the folded down seatback while the car is moving. This is an improper seating position since the seat has important crash protection features and seat belts are not available in this seat configuration.
- To reduce the risk of injury caused by sliding cargo within the passenger compartment of the vehicle, objects carried on the folded down seatback

should not extend higher than the top of the front seats.

To fold down the rear seatback:

1. Set the front seatback to the upright position and if necessary, slide the front seat forward.
2. Lower the rear headrests to the lowest position.



⚠ WARNING

Objects

Objects carried on the folded down seatback should not extend higher than the top of the front seatbacks. This could allow cargo to slide forward and cause injury or damage during sudden stops.

3. Pull on the seatback folding lever (1) located in the trunk.



4. If you pull both seatback folding levers, rear seatbacks will be folded.



- To use the rear seat, lift and pull the seatback rearward. Pull the seatback firmly until it clicks into place. Make sure the seatback is locked in place.

⚠ WARNING

Do not fold the rear passenger seats down until the driver has positioned his seat properly. Doing so can cause the driver to operate the vehicle out of position and increase the risk of bodily injury in a sudden stop or collision.

⚠ WARNING

Uprighting the seatback

When you return the seatback to its upright position, hold the seatback and return it slowly. If the seatback is returned without holding it, the back of the seat could spring forward, resulting in injury caused by being struck by the seatback.

⚠ WARNING

Rear Seatback

To ensure maximum protection in the event of an accident or sudden stop, when returning the rear seat to the upright position:

- Be careful not to damage the seat belt webbing or buckle.
- Do not allow the seat belt webbing or buckle to become pinched or caught in the rear seat.
- Ensure the seatback is completely locked into its upright position by pushing on the top of the seatback.

⚠ CAUTION

Damaging rear seat belt buckles

When you fold the rear seatback, insert the buckle between the rear seatback and cushion. Doing so can prevent the buckle from being damaged by the rear seatback.

⚠ CAUTION

Rear seat belts

When returning the rear seatbacks to the upright position, remember to return the rear shoulder belts to their proper position.

⚠ CAUTION

Be careful when loading cargo through the rear passenger seats to prevent damage to the vehicle interior.

⚠ WARNING

Cargo

Cargo should always be secured to prevent it from being thrown about the vehicle in a collision and causing injury to occupants. Do not place objects in the rear seats, since they cannot be properly secured and may hit the front seat occupants in a collision.

⚠ WARNING**Cargo loading**

Make sure the engine is off, the automatic transmission/dual clutch transmission is in P (Park) and the parking brake is securely applied whenever loading or unloading cargo. Failure to take these steps could result in vehicle movement if the shift lever is inadvertently moved to another position.

Seat belts

Seat belts are designed to bear upon the bony structure of the body and should be worn low across the front of the pelvis, chest and shoulders.

Seat belt restraint system

For maximum restraint system protection, seat belts must always be used whenever the vehicle is moving.

- A properly positioned shoulder belt should be positioned midway over your shoulder, across your collarbone.
- Never allow children to ride in the front passenger seat. See "Child Restraint System (CRS)" on page 3-25 for further discussion.

⚠ WARNING**Twisted seat belt**

Make sure your seat belt is not twisted when worn. A twisted seat belt may not properly protect you in an accident and could cut into your body.

⚠ WARNING**Shoulder Belt**

- Never wear the shoulder belt under your arm or behind your back. An improperly positioned shoulder belt cannot protect the occupant in an accident.
 - Always wear both the shoulder portion and lap portion of the lap/shoulder belt.
-

⚠ WARNING**Damaged seat belt**

Any damage to webbing or hardware may cause serious injury or death in an accident. Replace the entire seat belt assembly should be replaced by a Kia

authorized dealer if any part of the seat-belt webbing or hardware is damaged.

Seat belts are designed to bear upon the bony structure of the body and should be worn low across the front of the pelvis, chest and shoulders, wearing the lap section of the belt across the abdominal area must be avoided.

Seat belts should be adjusted as firmly as possible, consistent with comfort, to provide the most protection.

A slack belt will greatly reduce protection.

Care should be taken to avoid contamination of the webbing with polishes, oils, chemicals and particularly battery acid. Use mild soap and water. The belt should be replaced if webbing becomes frayed, contaminated or damaged.

- No modifications or additions should be made by the user which could either prevent the seat belt adjusting devices from operating to remove slack or prevent the seat belt assembly from being adjusted to remove slack.
- When you fasten the seat belt, be careful not to latch the seat belt in buckles of other seats. It is very dangerous and you may not be properly protected.
- Do not fasten and unfasten the seat belt repeatedly while driving. This could cause loss of control, and an accident causing death, serious injury, or property damage.
- When fastening the seat belt, make sure that the seat belt does not pass over objects that are hard or that can break easily.

⚠ WARNING

Seat belt buckle

Do not allow foreign material (gum, crumbs, coins, liquids, etc.) to obstruct the seat belt buckle orifice. This may prevent the seat belt from fastening securely.

Seat belt warning



The seat belt warning light and warning chime operate under the following conditions.

Driver and Front Passenger's seat belt warning

As a reminder, the driver and front passenger's seat belt warning lights will appear for approximately 6 seconds each time you turn the ENGINE START/STOP button ON regardless of belt fastening. If the seatbelt is not fastened, the warning chime will sound for about 6 seconds.

If you start to drive without the seat belt fastened over 9 km/h (5 mph) and less than 20 km/h (12 mph), the corresponding warning light will appear. The warning light will turn off when the vehicle speed drops below 9 km/h (5 mph).

If you start to drive without the seat belt fastened or you unfasten the seat belt when you drive 20 km/h (12 mph) and faster, the warning light will blink and warning chime will sound for approximately 100 seconds. When the seat belt is unfastened during driving, the warning light will appear when the speed is under 20 km/h (12 mph). When the

speed is 20 km/h (12 mph) and faster, the warning light will blink and warning chime will sound for approximately 100 seconds.

*** NOTICE**

- Even if the front passenger seat is not occupied, the seat belt warning light will appear for 6 seconds.
- The front passenger's seat belt warning may operate when luggage is placed on the front passenger seat.

Seat belt - Driver's 3-point system with emergency locking retractor

The following explains how to fasten and adjust the driver's seat belt.

Fastening the your seat belt:

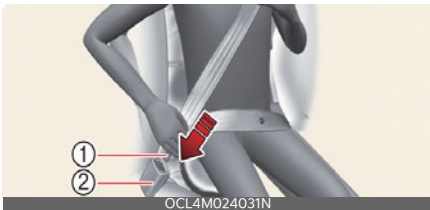

- Pull it out of the retractor and insert the metal tab (1) into the buckle (2). There will be an audible "click" when the tab locks into the buckle.

The seat belt automatically adjusts to the proper length only after the lap belt portion is adjusted manually so that it fits snugly around your hips. If you lean forward in a slow, easy motion, the belt will extend and let you move around. If there is a sudden stop or impact, however, the belt will lock into position. It will also lock if you try to lean forward too quickly.

⚠ WARNING

You should place the lap belt portion as low as possible and snugly across your hips. If the lap belt is located too high on your waist, it may increase the chance of injury in the event of a collision.



The arm closest to the seat belt buckle should be over the belt while the other arm should be under the belt as shown in the illustration. Never wear the seat belt under the arm closest to the door.

*** NOTICE**

If you are unable to pull out the seat belt from the retractor, firmly pull on the belt and release it. You should then be able to pull the belt out smoothly.

Releasing the seat belt:



- Press the release button (1) in the locking buckle.

When it is released, the belt should automatically draw back into the retractor.

If this does not happen, check the belt to be sure it is not twisted, then try again.

Adjusting the height of shoulder belt

You can adjust the height of the shoulder belt anchor to one of 4 positions for maximum comfort and safety.

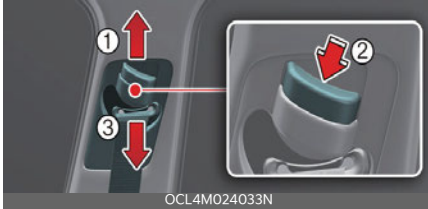

The height of the adjusting seat belt should not be too close to your neck. The shoulder portion should be adjusted so that it lies across your chest and mid-way over your shoulder near the door and not your neck.

To adjust the height of the seat belt anchor, lower or raise the height adjuster into an appropriate position.

- To raise the height adjuster, pull it up (1).
- To lower it, push it down (3) while pressing the height adjuster button (2).

Release the button to lock the anchor into position. Try sliding the height adjuster to make sure that it has locked into position.

Improperly positioned seat belts can cause serious injuries in an accident.

⚠ WARNING

Shoulder belt positioning

Verify the shoulder belt anchor is locked into position at the appropriate height. Never position the shoulder belt across your neck or face. Improperly positioned seat belts can cause serious injuries in an accident.

⚠ WARNING

Seat belt replacement

After a collision, the seat belt system should be inspected to ensure it is operating normally. Replace any belts that are not functioning appropriately.

Seat belts - Front passenger and rear seats' 3-point system with combination locking retractor

The following explains how to fasten the passenger's and rear seat belts.

Fastening your seat belt:

Combination retractor type seat belts are installed in the rear seat positions to help accommodate the installation of Child Restraint System. Although a combination retractor is also installed in the front passenger seat position, it is strongly recommended that children always be seated in the rear seat. NEVER place any infant restraint system in the front seat of your Kia.

This type of seat belt combines the features of both an emergency locking retractor seat belt and an automatic locking retractor seat belt.

- Pull it out of the retractor and insert the metal tab into the buckle. There will be an audible "click" when the tab locks into the buckle. When not securing a child restraint, the seat belt operates in the same way as the driver's seat belt (emergency locking retractor type).

It automatically adjusts to the proper length only after the lap belt portion of the seat belt is adjusted manually so that it fits snugly across your hips.

When the seat belt is fully extended from the retractor to allow the installation of a Child Restraint System, the seat

belt operation changes to allow the belt to retract, but not to extend (automatic locking retractor type). Refer to "Securing a child restraint with a lap/shoulder belt" on page 3-30.

*** NOTICE**

Although the combination retractor provides the same level of protection for seated occupant in either emergency or automatic locking modes, have the seated passengers use the emergency locking feature for improved convenience. The automatic locking function is intended to facilitate child restraint installation. To convert from the automatic locking feature to the emergency locking operation mode, allow the unbuckled seat belt to fully retract.

⚠ CAUTION

Do NOT fold down the left portion of the rear seatback when the rear center seat belt is buckled. ALWAYS UNBUCKLE the rear center seat belt before folding down the left portion of the rear seatback. If the rear center seat belt is buckled when the left portion of the rear seatback is folded down, distortion and damage to the top portion of the seatback and seat belt garnish may result, causing the seatback to lock into the folded down position.

The seat belt should be locked into the buckle on each seat cushion to be properly fastened.



- 1 Rear right seat belt fastening buckle
- 2 Rear center seat belt fastening buckle
- 3 Rear left seat belt fastening buckle

⚠ WARNING

Prior to fastening the rear seat belts, ensure the latch matches the seat belt buckle. Forcefully fastening the left or right seat belt to the center buckle can result in an improper fastening scenario that will not protect you in an accident.

When using the rear center seat belt, the buckle with the "CENTER" mark must be used.

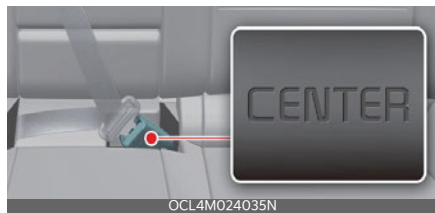

Stowing the rear seat belt

The rear seat belt buckles can be stowed in the pocket between the rear seatback and cushion when not in use.



- 1. Route the seat belt webbing through the rear seat belt guides. It will help

keep the belts from being trapped behind or under the seats.

2. After inserting the seat belt, tighten the belt webbing by pulling it up.

CAUTION

When pulling out to wear the seat belt, the tongue should be slowly pulled out of the seat belt guide so that the seat belt guide does not come off the trim.

Pre-tensioner seat belt



Your Kia is equipped with front driver and passenger, and rear passenger's (Except center) seat belt pre-tensioners. The purpose of the pre-tensioner is to make sure that the seat belts fit tightly against the occupant's body in certain collisions.

The pre-tensioner seat belts may be activated in a collision when the collision is severe enough.

When the vehicle stops suddenly, or if the occupant tries to lean forward too quickly, the seat belt retractor will lock into position. In certain frontal collisions, the pre-tensioner will activate and pull the seat belt into tighter contact against the occupant's body

If the system senses excessive tension on the front driver, front passenger, and rear passenger seat belts (except center) when the pre-tensioner system activates, the load limiter inside the retractor pre-tensioner will release some of the pressure on the affected seat belt.

WARNING

For your safety, be sure that the belt webbing is not loose or twisted and always sit properly in your seat.

NOTICE

The pre-tensioner may activate not only in a frontal collision but also in a side collision, if the vehicle is equipped with a side or curtain airbag.

The seat belt pre-tensioner system consists mainly of the following components. Their locations are shown in the illustration:

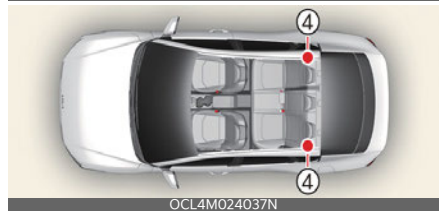
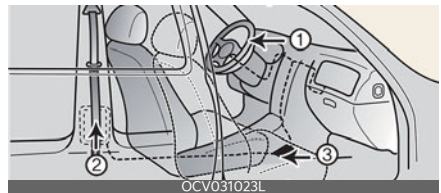

- 1 Supplemental Restraint System (SRS) airbag warning light
- 2 Retractor pre-tensioner assembly
- 3 SRS Control Module
- 4 2nd row retractor pre-tensioner assembly

WARNING

Skin Irritation

Wash all exposed skin areas thoroughly after an accident in which the pre-tensioner seat belts were activated. The fine dust from the pre-tensioner activation

may cause skin irritation and should not be inhaled for prolonged periods.

* NOTICE

- Both the driver's and front passenger's seat belt pre-tensioner systems may activate not only in certain frontal collisions, but also in certain side collisions or rollovers, if the vehicle is equipped with a side or curtain airbag.
- The SRS Control Module that activates the SRS airbag is connected to the pre-tensioner seat belt. The SRS airbag warning light  on the instrument panel will appear for approximately 3-6 seconds after the ignition switch has been turned to the ON position, and should then turn off.
- If the pre-tensioner seat belt system is not working properly, this warning light will appear even if there is not a malfunction of the SRS airbag. If the SRS airbag warning light does not illuminate when the ENGINE START/STOP button has been turned to the ON position, or if it remains illuminated for approximately 6 seconds, or if it illuminates while the vehicle is being driven, have an authorized Kia dealer inspect the pre-tensioner seat belt and SRS airbag system as soon as possible.

* NOTICE

Do not attempt to service or replace the pre-tensioner seat belt system in any manner. Do not attempt to inspect or replace the pre-tensioner seat belts yourself. This must be done by an authorized Kia dealer.

⚠ WARNING

Hot pre-tensioner

Do not touch the pre-tensioner seat belt assemblies for several minutes after they have been activated. When the pre-tensioner seat belt mechanism fires during a collision the pre-tensioner becomes hot and can burn you.

Pre-tensioners operate only one time. After activation, pre-tensioner seat belts must be replaced. If the pre-tensioner must be replaced, contact an authorized Kia dealer.

Seat belt precautions

Take the following precautions when using seat belts:

Infant or small child

Most countries have child restraint laws. You should be aware of the specific requirements in your country. Child and/or infant seats must be properly placed and installed in the rear seat. For more information about the use of these restraints, refer to "Child Restraint System (CRS)" on page 3-25.

* NOTICE

Children 13 and under are best protected from injury in an accident when properly restrained in the rear seat by a Child Restraint System that meets the requirements of the Safety Standards of your country. Before buying any Child Restraint System, make sure that it has a label certifying that it meets Safety Standards of your country. The restraint must be appropriate for your child's height and weight. Check the label on the child restraint for this information. Refer to

"Child Restraint System (CRS)" on page 3-25.

inflict injury to your child's neck, throat and face.

Larger children

Children who are too large for Child Restraint System must always sit in the rear seat and use the available lap/shoulder belts. The lap portion should be fastened snugly on the hips as low as possible. Check periodically to ensure that the belt fits. A squirming child could move the belt out of position. Children are given the most safety in the event of an accident when they are restrained by a proper restraint system in the rear seat. If a larger child (over age 13) must be seated in the front seat, the child should be securely restrained by the available lap/shoulder belt and the seat should be placed in the rearmost position. Children aged 13 and under should be restrained securely in the rear seat. NEVER place a child aged 13 and under in the front seat. NEVER place a rear facing child seat in the front seat of a vehicle.

If the shoulder belt portion touches the child's neck or face, try placing the child closer to the center of the vehicle. If the shoulder belt still touches their face or neck, you need to use a Child Restraint System.

WARNING

Small children

Do not allow small children to ride in the vehicle without an appropriate Child Restraint System. If the shoulder belt contacts your child's neck or face, your child is too small to ride in the vehicle without an appropriate Child Restraint System. In a collision, the seat belt will

Restraint of pregnant women

Pregnant women should wear lap/shoulder belt assemblies whenever possible according to specific recommendations by their doctors. The lap portion of the belt should be worn AS SECURELY AND LOW AS POSSIBLE.

WARNING

Pregnant women

Pregnant women must never place the lap portion of the seat belt above or on the abdomen where the fetus is located. The force of the seat belt during a collision can seriously injure the fetus.

Injured person

A seat belt should be used when an injured person is being transported. When this is necessary, you should consult a physician for recommendations.

One person per belt

Two people (including children) should never attempt to use a single seat belt. This could increase injury severity in an accident.

Do not lie down

To reduce the chance of injuries in the event of an accident and to achieve maximum effectiveness of the restraint system, all passengers should be sitting up and the front and rear seats should be in an upright position when the vehicle is moving. A seat belt cannot provide proper protection if a person is lying

down in the rear seat or if the front and rear seats are in a reclined position.

Care of seat belts

Seat belt systems should never be disassembled or modified. Care should be taken to assure that seat belts and belt hardware are not damaged by seat hinges, doors or other abuse.

WARNING

Pinched seat belt

Make sure that the webbing and/or buckle does not get caught or pinched in the rear seat when returning the rear seatback to its upright position. A caught or pinched webbing/buckle may become damaged and could fail during a collision or sudden stop.

WARNING

Seatbelts can become hot in a vehicle that has been closed up in sunny weather. Please handle with care, as they could burn infants and children.

Periodic inspection

All seat belts should be inspected periodically for any wear or damage. For your safety, any damaged parts should be replaced as soon as possible by a Kia authorized dealer.

Keep belts clean and dry

Seat belts should be kept clean and dry. If belts become dirty, they can be cleaned by using a mild soap solution and warm water. Bleach, dye, strong detergents or abrasives should not be used because they may damage and weaken the fabric.

When to replace seat belts

The seat belt assembly should be replaced if the vehicle has been involved in an accident even if no damage is visible. Additional questions concerning seat belt operation should be directed to an authorized Kia dealer.

Child Restraint System (CRS)

Infants and younger children must be restrained in the rear with an appropriate rear-facing or forward-facing CRS that has first been properly secured to the rear seat of the vehicle.

Please refer to your state or federal laws for child seating requirements in the operation of a motor vehicle.

Children always in the rear

Children age 13 and under must always ride in the rear seats and must always be properly restrained to minimize the risk of injury in an accident, sudden stop or sudden maneuver.

WARNING

Restraint Location

Never install a child or infant seat on the front passenger's seat. A child riding in the front can be forcefully struck by an inflating airbag and seriously injured.

WARNING

Hot Child Restraint

A CRS can become very hot if it is left in a closed vehicle on a sunny day. Check the seat cover, buckles and latches before placing a child in the restraint system.

According to accident statistics, children age 13 and under are safer when properly restrained in the rear seats than in the front seat. Even with airbags, children can be seriously injured or killed. Children too large for a child restraint must use the seat belts provided.

Most countries have child restraint laws which require children to travel in approved child restraint devices. The laws governing the age or height/weight

restrictions at which seat belts can be used instead of child restraints differs among countries so you should be aware of the specific requirements in your countries and where you are traveling.

The CRS must be properly placed and installed in the rear seat. You must use a commercially available CRS that meets the Safety Standards of your country.

A CRS is designed to be secured in a vehicle seat by lap belt portion of a lap/shoulder belt, or by a LATCH system in the rear seats of the vehicle.

Child Restraint System (CRS)

Infants and younger children must be restrained in an appropriate rear-facing or forward-facing CRS that has first been properly secured to the rear seat of the vehicle. Read and comply with the instructions for installation and use provided by the manufacturer of the CRS.

CRS Installation

An improperly secured child restraint can increase the risk of serious injury or death in an accident. Always take the following precautions when using a CRS:

- Always follow the CRS manufacturer's instructions for installation and use.
- Always properly restrain your child in the child restraint.
- If the head rest prevents proper installation of a child seat (as described in the CRS manual), the head rest of the respective seating position should be readjusted or entirely removed.
- Do not use an infant carrier or a child safety seat that "hooks" over a seat-

back as it may not provide adequate protection in an accident.

- A child restraint in the center seating position may also contact or push up against the safety belt buckles, which can damage the buckles and make them unusable or unsafe. Always check that the child restraint does not contact any of the safety belt buckles. Check the placement of the child restraint regularly to make sure that it has not shifted and contacts the safety belt buckles.

* NOTICE

After an accident, have a Kia dealer check the CRS, seat belts, tether anchors and lower anchors.

Selecting a CRS

When selecting a CRS for your child, always:

- Make sure the CRS has a label certifying that it meets applicable Safety Standards of your country.
- Select a child restraint based on your child's height and weight. The required label or the instructions for use typically provide this information.
- Select a child restraint that fits the vehicle seating position where it will be used.
- Read and comply with the warnings and instructions for installation and use provided with the CRS.
- The American Academy of Pediatrics provides helpful fit and safety information about child restraints at www.healthychildren.org.

⚠ WARNING

Holding children

Never hold a child in your arms or lap when riding in a vehicle. The violent forces created during a crash will tear the child from your arms and throw the child against the car's interior. Always use a Child Restraint System which is appropriate for your child's height and weight.

⚠ WARNING

Unattended children, the elderly or pets

An enclosed vehicle can become extremely hot, causing death or severe injury such as heatstroke to unattended children, the elderly or pets who cannot escape the vehicle. When left or trapped in a hot vehicle, make sure to stay hydrated and avoid sun exposure through the vehicle's windshield.

Furthermore, children might operate features of the vehicle that could injure them, or they could encounter other harm, possibly from someone gaining entry to the vehicle. NEVER leave children or animals unattended in your vehicle.

⚠ WARNING

Seat belt use

Do not use one seat belt for two occupants at the same time. This will eliminate any safety benefit provided by the seat belt to the occupants.

CRS types

There are three main types of the CRS: rear-facing seats, forward-facing seats, and booster seats. They are classified according to the child's age, height and weight.

Backward-facing child seats



A rear-facing child seat provides restraint with the seating surface against the back of the child. The harness system holds the child in place, and in an accident, acts to keep the child positioned in the seat and reduces the stress to the neck and spinal cord.

All children under age one must always ride in a rear-facing infant child restraint.

Convertible and 3-in-1 child seats typically have higher height and weight limits for the rear-facing position, allowing you to keep your child rear-facing for a longer period.

Continue to use a rear-facing child seat for as long as your child will fit within the height and weight limits allowed by the child seat manufacturer. It's the best way to keep them safe. Once your child has outgrown the rear-facing child restraint, your child is ready for a forward-facing child restraint with a harness.

Forward-facing child restraints



A forward-facing child seat provides restraint for the child's body with a harness. Keep children in a forward-facing child seat with a harness until they reach the top height or weight limit allowed by your child restraint's manufacturer.

Once your child outgrows the forward-facing child restraint, your child is ready for a booster seat.

Booster seats

A booster seat is a restraint designed to improve the fit of the vehicle's seat belt system. A booster seat positions the seat belt so that it fits properly over the lap of your child.

Keep your child in a booster seat until they are big enough to sit in the seat without a booster and still have the seat belt fit properly. For a seat belt to fit properly, the lap belt must lie snugly across the upper thighs, not the stomach. The shoulder belt should lie snug across the shoulder and chest and not across the neck or face. Children age 13 and under must always ride in the rear seats and must always be properly restrained to minimize the risk of injury.

Installing a Child Restraint System (CRS)

After selecting a proper child seat for your child, check to make sure it fits properly in your Kia.

Follow the instructions provided by the manufacturer when installing the child seat. Note these general steps when installing the seat to your Kia:

- **Properly secure the child restraint to the vehicle.** All child restraints must be secured to the vehicle with the lap part of a lap/shoulder belt or with the lower Anchors and Tether for children (LATCH) system.
- **Make sure the child restraint is firmly secured.** After installing a child restraint to the vehicle, push and pull the seat forward and from side-to-side to verify that it is securely attached to the seat. A child restraint secured with a seat belt should be installed as firmly as possible. However, some side-to-side movement can be expected.
- **Secure the child in the child restraint.** Make sure the child is properly strapped in the child restraint according to the manufacturer instructions.

LATCH system

The LATCH system holds a child restraint during driving and in an accident. This system is designed to make installation of the child restraint easier and reduce the possibility of improperly installing your child restraint. The LATCH system uses anchors in the vehicle and attachments on the child restraint. The LATCH system eliminates the need to use seat belts to secure the child restraint to the rear seats.

Lower anchors are metal bars built into the vehicle. There are two lower anchors for each LATCH seating position that will accommodate a child restraint with lower attachments.

To use the LATCH system in your Kia, you must have a child restraint with LATCH attachments.

The child seat manufacturer will provide you with instructions on how to use the child seat with its attachments for the LATCH lower anchors.



LATCH anchors have been provided in the left and right outboard rear seating positions. Their locations are shown in the illustration. There are no LATCH anchors provided for the center rear seating position.

⚠ WARNING

LATCH Lower Anchors

Never attempt to attach a LATCH equipped seat in the center seating position. LATCH lower anchors are only to be used in the left and right rear outboard seating positions. You may damage the anchors or the anchors may fail and break in a collision if the seat is in the center seating position.

The lower anchor position indicator symbols are located on the left and right rear seatbacks to identify the position of the lower anchors in your Kia (see arrows in illustration).

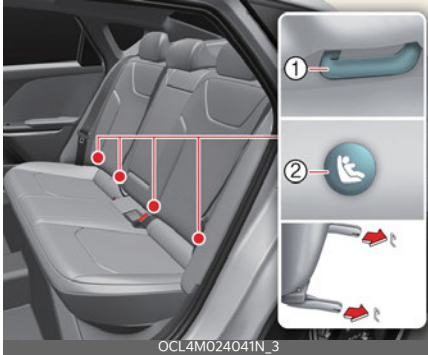

1 Lower Anchor

2 Lower Anchor position indicator

The LATCH anchors are located between the seatback and the seat cushion of the rear seat left and right outboard seating positions.

To use the lower anchor, push the upper portion of the lower anchor cover.

Securing a child restraint with the LATCH anchors system

To install a LATCH-compatible child restraint in either of the rear outboard seating positions:

1. Move the seat belt buckle away from the lower anchors. Otherwise, the webbing or buckle can be damaged by the latch anchor, which can make them become unusable or unsafe.
2. Move any other objects away from the anchors that could prevent a secure connection between the child restraint and the lower anchors.
3. Place the child restraint on the vehicle seat, then attach the seat to the lower anchors according to the instructions provided by the child restraint manufacturer.
4. Follow the child restraint manufacturer's instructions for properly adjusting and tightening the lower

attachments on the child restraint to the lower anchors.

⚠ WARNING

Take the following precautions when using the LATCH system:

- Read and follow all installation instructions provided with your Child Restraint System.
- To prevent a child from playing with unused seat belts, buckle all unused rear seat belts before the child is placed into the vehicle. Lock each unused seatbelt following the instructions in the "automatic locking mode" subsection, and place the webbing behind the child seat or against an unused seatback. Children can be strangled if a shoulder belt becomes wrapped around their neck and the seat belt tightens.
- NEVER attach more than one child restraint to a single anchor. This could cause the anchor or attachment to come loose or break.
- Always have the LATCH system inspected by your authorized Kia dealer after an accident. An accident can damage the LATCH system and may not properly secure the child restraint.

Securing a child restraint seat with "Tether Anchor" system

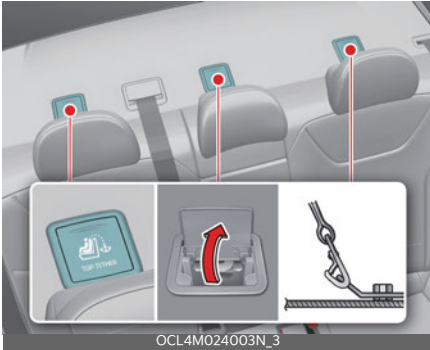

OCL4M024003N_3

First secure the child restraint with the LATCH lower anchors or the seat belt. If the child restraint manufacturer recommends that the top tether strap be attached, attach and tighten the top tether strap to the top tether strap anchor.

Child Restraint hook holders are located on the package tray.

⚠ WARNING

Take the following precautions when installing the tether strap:

- Read and follow all installation instructions provided with your Child Restraint System.
- NEVER attach more than one child restraint to a single tether anchor. This could cause the anchor or attachment to come loose or break.
- Do not attach the tether strap to anything other than the correct tether anchor. It may not work properly if attached to something else.
- Do not use the tether anchors for adult seat belts or harnesses, or for attaching other items or equipment to the vehicle.

- Always fasten the seat belts behind the child restraint seat when they are not used to secure the child seat. Failure to do so may result in child strangulation.

To install the tether anchor:



OCL4M024043N

1. Route the Child Restraint System seat strap over the seatback.
For vehicles with adjustable headrest, route the tether strap under the headrest and between the headrest posts, or route the tether strap over the top of the seatback.
2. Connect the tether to the tether anchorage, then tighten the tether according to the instructions of your Child Restraint System's manufacturer to firmly attach the Child Restraint System to the seat.
3. Check that the child restraint is securely attached to the seat by pushing and pulling the seat forward and from side-to-side.

Securing a child restraint with a lap/shoulder belt

When not using the LATCH system, all child restraints must be secured to a vehicle rear seat with the lap part of a lap/shoulder belt.

Automatic locking mode



All passenger seat belts move freely under normal conditions and only lock under extreme or emergency conditions (emergency locking mode). To secure a child restraint, you must manually pull the seat belt all the way out to shift the retractor to the "automatic locking" mode.

The "automatic locking" mode will help prevent the normal movement of the child in the vehicle from causing the seat belt to loosen and compromise the CRS.

To install a CRS on the rear seats, do the following:

1. Place the CRS on a rear seat and route the lap/shoulder belt around or through the child restraint, following the restraint manufacturer's instructions.
Be sure the seat belt webbing is not twisted.
2. Fasten the lap/shoulder belt latch into the buckle. Listen for the distinct "click" sound.

Position the release button so that it is easy to access in case of an emergency.



3. Pull the shoulder portion of the seat belt all the way out. When it is fully extended, it will shift the retractor to the "automatic locking" (child restraint) mode.



4. Slowly allow the shoulder portion of the seat belt to retract and listen for an audible "clicking" or "ratcheting" sound. This indicates that the retractor is in the "automatic locking" mode. If no distinct sound is heard, repeat steps 3 and 4.



5. Remove as much slack from the belt as possible by pushing down on the CRS while feeding the shoulder belt back into the retractor.
6. Push and pull on the CRS to confirm that the seat belt is holding it firmly in place. If it is not, release the seat belt and repeat steps 2 through 6.
7. Double check that the retractor is in the "automatic locking" mode by attempting to pull more of the seat

belt out of the retractor. If you cannot, the retractor is in the "automatic locking" mode.

If your CRS manufacturer instructs or recommends you use a tether anchor with the lap/shoulder belt, refer to "Securing a child restraint seat with "Tether Anchor" system" on page 3-30 for more information.

* NOTICE

When the seat belt is allowed to retract to its fully stowed position, the retractor will automatically switch from the "automatic locking" mode to the emergency lock mode for normal adult usage.

⚠ WARNING

Auto lock mode

Set the retractor to Automatic Lock mode when installing any CRS. If the retractor is not in the automatic locking mode, the child restraint can move when your Kia turns or stops suddenly. A child can be seriously injured or killed if the child restraint is not properly anchored in the car.

To remove the child restraint, press the release button on the buckle and then pull the lap/shoulder belt out of the restraint and allow the seat belt to retract fully.

Airbag — Advanced Supplemental Restraint System

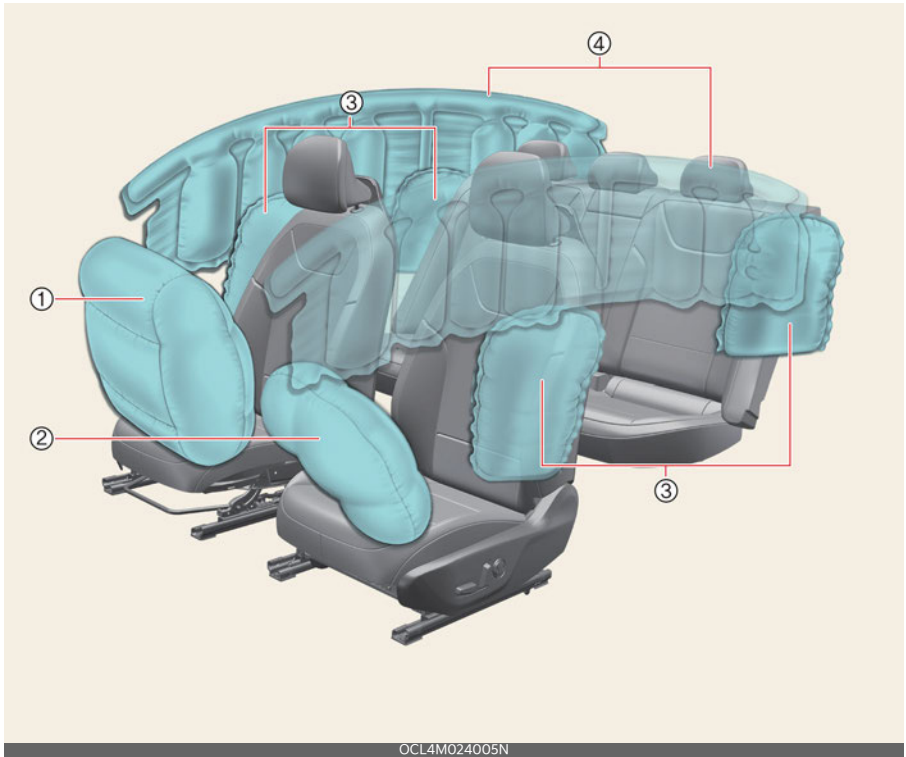

* The actual airbags in the vehicle may differ from the illustration.

- 1 Passenger's front airbag
- 2 Driver's front airbag
- 3 Side airbag
- 4 Curtain airbag

Even in vehicles with airbags, you and your passengers must always wear the safety belts provided to minimize the risk and severity of injury in the event of a collision or rollover.

How does the airbag system operate?

- Airbags are activated (able to inflate if necessary) only when the ENGINE START/STOP button is in the ON position or approximately within 3 minutes after ignition off.
- The appropriate airbags inflate instantly in the event of a serious frontal collision or side collision to help protect the occupants from serious physical injury.
- There is no single speed at which the airbags will inflate. Generally, airbags are designed to inflate based on the severity of a collision and its direction, etc. Several factors determine whether the SRS Control Module produce an electronic deployment/inflation signal.
- Airbags will not deploy in every collision. Airbag deployment depends on several factors including vehicle speed, angles of impact, and, the density and stiffness of the vehicles or objects of impacts.
- The front airbags will completely inflate and deflate in an instant. It is virtually impossible for you to see the airbags inflate during an accident. It is much more likely that you will simply see the deflated airbags hanging out of their storage compartments after the collision.
- In addition to inflating in serious side collisions, side and/or curtain airbags will inflate if the sensing system detects a rollover.
- When a rollover is detected, side and/or curtain airbags will remain inflated longer. This helps provide protection from ejection, especially when used in conjunction with the seat belts.

- To help provide protection, the airbags must inflate rapidly. The airbag inflates extremely fast between the occupant and vehicle structures before the occupant impacts vehicle structures. This speed of inflation reduces the risk of serious or life-threatening injuries and is thus a necessary part of the airbag design. However, airbag inflation can also cause injuries including facial abrasions, bruises and broken bones because the inflation speed also causes the airbags to expand with a great deal of force.
- **There are even circumstances under which contact with the steering wheel or passenger airbag can cause fatal injuries, especially if the occupant is positioned excessively close to the steering wheel or passenger airbag.**

WARNING

Airbag inflation

Sit as far back as possible from the steering wheel while still maintaining comfortable control of your Kia. A distance of at least 25 cm (10 inches) from your chest to the steering wheel is recommended. Failure to do so can result in airbag inflation injuries.

Noise and smoke

When inflated, the airbags make a loud noise and release smoke and powder in the vehicle. This is normal and is a result of the ignition of the airbag inflator. After the airbag inflates, you may feel substantial discomfort in breathing due to the contact of your chest with both the seat belt and the airbag, as well as from breathing the smoke and powder. **Open**

your doors and/or windows as soon as possible after impact to reduce discomfort and prevent prolonged exposure to the smoke and powder.

Though the smoke and powder are non-toxic, they may cause irritation to the skin (eyes, nose and throat, etc.). Wash and rinse with cold water immediately and consult a doctor if symptoms persist.

⚠ WARNING

Hot components

Do not touch the airbag storage area's internal components immediately after airbag inflation. The components in the steering wheel, instrument panel and the roof rails above the front and rear doors are very hot and can cause burn injuries.

⚠ WARNING

Do not install or place any accessories near airbag deployment areas, such as the instrument panel, windows, pillars, and roof rails.

Do not install a child restraint on the front passenger's seat



Never place a rear-facing child restraint in the front passenger's seat.

If the airbag deploys, it would impact the rear-facing child restraint, causing serious or fatal injury.

Do not place front-facing child restraints in the front passenger's seat. If the front

passenger airbag inflates, it could cause serious or fatal injuries to the child.

⚠ WARNING

Airbag deployment

When children are seated in the rear outboard seats of a vehicle equipped with side and/or curtain airbags, install the CRS as far away from the door as possible. Inflation of the side and/or curtain airbags could impact the child.

Airbag warning light

The purpose of the airbag warning light in your instrument panel is to alert you of a potential problem with your airbag system, which could include your side and/or curtain airbags used for rollover protection.



If the airbag warning light illuminates for more than 6 seconds after the ENGINE START/STOP button has been turned to the ON position, or if it illuminates during operation, a Supplemental Restraint System (SRS) component may not be functioning properly. Have your vehicle checked by an authorized Kia dealer.

If any of the following conditions occur, this indicates a malfunction in the airbag system. Have an authorized Kia dealer inspect the airbag system as soon as possible.

- The light does not turn on briefly when you turn the ENGINE START/STOP button to the ON position.
- The light stays on after illuminating for approximately 6 seconds.

- The light turns on while the vehicle is in motion.
- The light blinks when the ENGINE START/STOP button is turned to the ON position.

SRS components and functions

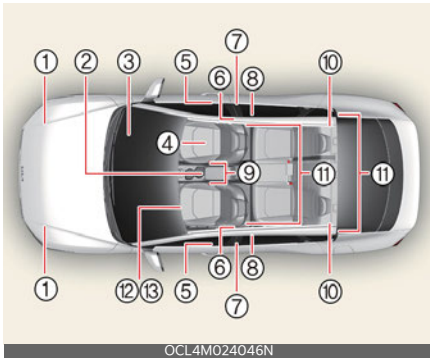

* The actual position of SRS components may differ from the illustration.
The SRS consists of the following components:

- 1 Front impact sensors
- 2 SRS control module (SRSCM)/rollover sensor
- 3 Passenger's front airbag module
- 4 Occupant Detection System (ODS) (Front passenger's seat only)
- 5 Side pressure sensors
- 6 Front side airbag modules
- 7 Curtain airbag modules
- 8 Side impact sensors
- 9 Front driver/passenger's seat belt buckle sensor
- 10 Rear side airbag modules
- 11 Retractor pre-tensioner assemblies
- 12 Driver's front airbag module
- 13 Airbag warning light

The SRSCM continually monitors all elements while the ENGINE START/STOP

button is in the ON Position or approximately within 3 minutes after ignition off to determine if a frontal, near-frontal impact or side impact is severe enough to require airbag deployment or pre-tensioner seat belt deployment.

The SRS airbag warning light on the instrument panel will appear for about 3-6 seconds after the ENGINE START/STOP button is turned to the ON position, after which the airbag warning light should go out.

WARNING

If any of the following conditions occurs, this indicates a malfunction of the SRS. Have the system inspected by an authorized Kia dealer.

- The light does not turn on briefly when you turn the ignition ON.
- The light stays on after appearing for approximately 6 seconds.
- The light comes on while the vehicle is in motion.
- The light blinks when the ENGINE START/STOP button is in ON position.

Driver's front airbag (1)



The airbag modules are located both in the center of the steering wheel and in the front passenger's panel above the glove box. When the SRSCM detects a sufficiently severe impact to the front of the vehicle, it will automatically deploy the front airbags.

Driver's front airbag (2)



Upon deployment, tear seams molded directly into the pad covers will separate under pressure from the expansion of the airbags. Further opening of the covers then allows full inflation of the airbags.

Driver's front airbag (3)



A fully inflated airbag, in combination with a properly worn seat belt, slows the driver's or the passenger's forward motion, reducing the risk of head and chest injury.

After complete inflation, the airbag immediately starts deflating, enabling the driver to maintain forward visibility and the ability to steer or operate other controls.

Passenger's front airbag



⚠ WARNING

Airbag obstructions

Do not install or place any accessories on the steering wheel, instrument panel, or on the front passenger's panel above the glove box in a vehicle. Such objects may become dangerous projectiles if the airbag deploys.

⚠ WARNING

Flying objects

Do not place any objects (an umbrella, bag, etc.) between the front door and the front seat. Such objects may become dangerous projectiles if the side airbag inflates.

- If an airbag deploys, there may be a loud noise and powder released in the vehicle. These conditions are normal and are non-toxic. The airbags are packed in this fine powder. The dust generated during airbag deployment may cause skin or eye irritation as well as aggravate asthma for some persons. Wash all exposed skin areas thoroughly with cold water and a mild soap after an accident in which the airbags were deployed.
- The SRS can function only when the ENGINE START/STOP button is in the ON Position or approximately within 3 minutes after ignition off. The SRS is not working properly if any of the following situations occur:
 - the SRS warning light does not illuminate
 - the SRS airbag warning light remains on continuously after appearing for about 3-6 seconds when the ENGINE START/STOP button is turned to the ON position.

- the SRS airbag warning light comes on while driving

Have your Kia immediately inspected by an authorized Kia dealer.

*** NOTICE**

Before replacing a fuse or disconnecting a battery terminal, change the ENGINE START/STOP button to the OFF position. Never remove or replace an airbag related fuse(s) when the ENGINE START/STOP button is in the ON position. Failure to heed this warning will cause the SRS airbag warning light to appear.

Occupant Detection System (ODS)

Your Kia is equipped with an ODS in the front passenger's seat.



The ODS is designed to detect the presence of a properly seated front passenger and determine if the passenger's front airbag should be activated (may inflate) or not. Only the front passenger front airbag is controlled by the ODS.

Do not put anything in front of the passenger airbag "⊗" indicator.

Main components of the ODS

- A detection device is located within the front passenger seat cushion.
- An electronic system determines whether the passenger airbag systems should be activated or deactivated.
- An indicator light located on the overhead console which illuminates the words PASSENGER AIR BAG "⊗" indicates the front passenger airbag system is deactivated.
- The instrument panel air bag warning light is interconnected with the occupant detection system.

If the front passenger seat is occupied by a person that the system determines to be of appropriate size, and is seated properly (upright with the seatback in an upright position, centered on the seat cushion with seat belt on, legs comfort-

ably extended and feet on the floor), the PASSENGER AIR BAG "⊗2" indicator will turn off and the front passenger's airbag will be able to inflate, if necessary, in frontal crashes.

You will find the PASSENGER AIR BAG "⊗2" indicator on the overhead console.

This system detects the conditions 1-4 in the following table and activates or deactivates the front passenger airbag based on these conditions.

Always be sure that you and all vehicle occupants are seated and restrained properly (sitting upright with the seat in an upright position, centered on the seat cushion, with the person's legs comfortably extended, feet on the floor, and wearing the seat belt properly) for the most effective protection by the airbag and the safety belt.

The ODS may not function properly if the passenger takes actions which can defeat the detection system. These include:

- Failing to sit in an upright position.
- Leaning against the door or center console.
- Sitting towards the sides or the front of the seat.
- Putting legs on the dashboard or resting them on other locations which reduce the passenger weight on the front seat.
- Improperly wearing the seat belt.
- Reclining the seatback.

Conditions and operation of the front passenger ODS

Condition detected by the occupant detection system	Indicator/Warning light		Devices
	"PASSENGER AIR BAG OFF" indicator light	SRS warning light	Front passenger airbag
1. Adult ¹	Off	Off	Activated
2. Child Restraint System (CRS) with child under 12 months old ^{2 3 4}	On	Off	Deactivated
3. Unoccupied	On	Off	Deactivated
4. Malfunction in the system	Off	On	Activated

1. The system determines a person of adult size as an adult. When a smaller adult sits in the front passenger seat, the system may recognize him/her as a child depending on his/her size and seating position.

2. Do not allow children to ride in the front passenger seat. When a larger child who has outgrown a CRS sits in the front passenger seat, the system may recognize him/her as an adult depending upon his/her size or seated position.

3. Never install a CRS on the front passenger seat.

4. The PASSENGER AIR BAG "  " indicator may turn on or off when a child above 12 months to 12 years old (with or without a CRS) sits in the front passenger seat. This is a normal condition.

WARNING

- Do not install a child restraint seat on the passenger seat when the soaked with liquid.
- Do not modify the ODS. This may damage the system and prevent its proper function in a collision.

- Any service related to the passenger seat and the ODS must be done at an authorized Kia dealership.
- After the passenger seat has been removed or installed for repair purposes, check for normal operation of the PASSENGER AIR BAG "  " and airbag warning lights with a person seated and not seated in the passenger seat.

NOTICE

- Do not use car seat cushions or after-market manufactured passenger seat heaters that cover the surface of the seat.
- After cleaning the interior with steam or detergent, the seat should be thoroughly dried. Check for normal operation of the PASSENGER AIR BAG "OFF" and airbag warning lights.

NOTICE

When the PASSENGER AIR BAG "  " symbol appears, the passenger airbag system will not operate. The passenger airbag system will operate when necessary if the symbol is not illuminated.

*** NOTICE**

Do not modify or replace the front passenger seat. Don't place anything on or attach anything such as a blanket, front seat cover or aftermarket seat heater to the front passenger seat. This can adversely affect the ODS.

⚠ WARNING

ODS

Riding in an improper position adversely affects the ODS and may result in the deactivation of the front passenger airbag. It is important for you to instruct the passenger as to the proper sitting positions as contained in this manual.

- Do not place a heavy load in the front passenger seatback pocket or on the front passenger seat.



- Do not place feet on the front passenger seatback.



- Never sit with hips shifted towards the front of the seat.



- Never excessively recline the front passenger seatback.



- Never place feet on the dashboard.



- Never lean on the door or center console.



- Never sit on one side of the front passenger seat.
- Do not use car seat accessories such as thick blankets and cushions which cover up the car seat surface.
- Do not place electronic devices such as laptops, DVD player, satellite radios or heavy materials such as water bottles on the passenger seat.

- Wet passenger seat:

Do not spill liquid in the passenger seat. Spilled liquid on the passenger seat may cause the airbag warning light to appear or malfunction. If any liquid is spilled, make sure the seat has been completely dried before driving the vehicle.

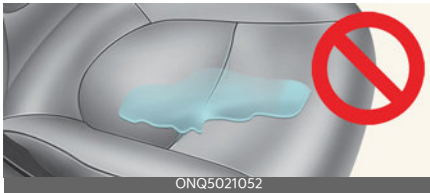

Proper position



When an adult is seated in the front passenger seat, if the PASSENGER AIR BAG "⊗₂" indicator is on, change the ENGINE START/STOP button to the OFF position and have the passenger sit properly (sitting upright with the seatback in an upright position, centered on the seat cushion with their seat belt on, legs comfortably extended and feet on the floor). Restart the vehicle and ensure the passenger remains in that position. This will allow the system to detect the passenger and to enable the passenger airbag.

If the PASSENGER AIR BAG "⊗₂" indicator is still on, have the passenger move to the rear seat.

WARNING

PASSENGER AIR BAG "⊗₂" light

Do not allow an adult passenger to ride in the front seat when the PASSENGER AIR BAG "⊗₂" indicator is illuminated, because the airbag will not deploy in the event of a collision. Have the passenger reposition in the seat. Failure to properly position may lead to airbag deactivation resulting in airbag non-deployment in a collision. If the PASSENGER AIR BAG "⊗₂" indicator remains illuminated after repositioned properly and the vehicle is restarted, have the passenger move to the rear seat because the front airbag will not deploy.

*** NOTICE**

The PASSENGER AIR BAG "⊗₂" indicator does not illuminate if the front passenger seat is occupied, the occupant detection sensor will then classify the front passenger after several more seconds.

- Even though your Kia is equipped with the ODS, never install a CRS in the front passenger's seat. A deploying airbag can forcefully strike a child resulting in serious injuries or death. Any child age 13 and under should ride in the rear seat. Children too large for child restraints should use the available lap/shoulder belts. No matter what type of collision, children of all ages are safer when restrained in the rear seat. If the ODS malfunctions, the SRS warning light on the instrument panel will illuminate because the passenger's front airbag is connected to the ODS. If there is a malfunction of the ODS the PASSEN-

GER AIR BAG "⊗" indicator will not illuminate and the passenger's front airbag will inflate in frontal collision even if there is no occupant in the front passenger seat.

Driver's and passenger's front airbag

Your Kia is equipped with an advanced SRS and lap/shoulder belts at both the driver and passenger seating position.

Driver's front airbag/Passenger's front airbag



The indicators are the words "AIR BAG" located on the airbag pad cover and the passenger's side front panel pad above the glove box.

The SRS consists of airbags installed under the pad covers in the center of the steering wheel and the passenger's side front panel above the glove box.

The purpose of the SRS is to provide the vehicle's driver and/or the front passenger with additional protection of the seat belt system alone in case of a frontal impact of sufficient severity. The SRS uses sensors to gather information about the driver's and front passenger's seat belt usage and impact severity.

The seat belt buckle sensor determines if the front passenger's seat belt is fastened.

These sensors provide the ability to control the SRS deployment based on

whether the seat belts are fastened, and how severe the impact is.

The advanced SRS offers the ability to control the airbag inflation with two levels. A first stage level is provided for moderate impacts. A second stage level is provided for severe impacts.

According to the impact severity and seat belt usage, the SRSCM controls airbag inflation. Failure to properly wear seat belts can increase the risk or severity of injury in an accident.

Your Kia is equipped with an ODS in the front passenger's seat. The ODS detects the presence of a passenger in the front passenger's seat and will turn off the front passenger's airbag under certain conditions. For more detail, see "Occupant Detection System (ODS)" on page 3-38.

⚠ WARNING

Modification to the seat structure can cause the airbag to deploy at a different level than should be provided.

Manufacturers are required by government regulations to provide a contact point concerning modifications to the vehicle for persons with disabilities, which modifications may affect the vehicle's advanced airbag system. That contact is Kia's toll-free Customer Experience Department at 1-877-KIA-AUTO (1-877-542-2886). Kia neither endorses nor will it support any changes to any part or structure of the vehicle that could affect the advanced airbag system, including the ODS.

⚠ WARNING

Replacement/modifications

The front passenger seat, dashboard or door should not be replaced except by

an authorized Kia dealer using original Kia parts designed for this vehicle and model. Any other such replacement or modification could adversely affect the operation of the Occupant Detection System and your advanced airbags.

Advanced airbags are combined with pre-tensioner seat belts to help provide enhanced occupant protection in frontal crashes. Front airbags are not intended to deploy in collisions in which sufficient protection can be provided by the seat belt.

*** NOTICE**

Airbags can only be used once - have an authorized Kia dealer replace the airbag immediately after deployment.

Front airbags are not intended to deploy in side-impacts, rear-impacts or roll-overs. When the frontal deployment threshold is satisfied in a side-impact, the front airbags may deploy. In addition, front airbags will not deploy in frontal impact below the deployment threshold.

⚠ WARNING

SRS wiring

Do not tamper with or disconnect SRS wiring or other components of the SRS system. This could result in injury, due to accidental deployment of the airbags or by rendering the SRS inoperative.

⚠ WARNING

Do not attach objects

No objects (such as an instrument panel cover, mobile phone holder, cup holder, perfume, stickers, etc.) should be placed over or near the airbag modules on the steering wheel, instrument panel, wind-

shield glass or front passenger's instrument panel above the glove box. Such objects could cause harm if the vehicle is in a collision severe enough to deploy the airbags.

Do not place any objects over the airbag or between the airbag and yourself.

Never place or insert any object into any small opening near side airbag labels attached to the vehicle seats.

When the airbag deploys, the object may affect the deployment and result in an unexpected accident or injury.

Side airbag

Your vehicle is equipped with a side airbag in each front and rear seat.



Front seat



Rear seat



* The actual airbags in the vehicle may differ from the illustration.

The purpose of these airbags is to provide the vehicle's driver and/or the front passenger with additional protection than that offered by the seat belts alone.

- The side airbags are designed to deploy during certain side-impact collisions, depending on the crash severity of the impact
- The side airbags may deploy on the side of the impact or on both sides.
- The side and/or curtain airbags on both sides of the vehicle will deploy if a rollover or possible rollover is detected.
- The side airbags are not designed to deploy in all side impact or rollover situations.

⚠ WARNING

Unexpected deployment

Avoid impact to the side impact airbag sensor when the ENGINE START/STOP button is ON to prevent unexpected deployment of the side airbag.

- The side airbag is supplemental to the driver's and the passenger's seat belt systems and is not a substitute for them. Your seat belts must be worn at all times while the vehicle is in operation.
- For best protection from the side airbag system and to avoid being injured by the deploying side airbag, both front seat occupants should sit in an upright position with the seat belts properly fastened. The driver's hands should be placed on the steering wheel at the 9:00 and 3:00 positions. The passenger's arms and hands should be placed on their laps.

⚠ WARNING

Deployment

Do not install any accessories including seat covers, on the side or near the side airbag as this may affect the deployment of the side airbags.

- If the seat or seat cover is damaged, have the vehicle checked and repaired by an authorized Kia dealer. Inform the dealer that your vehicle is equipped with side airbags and an ODS.

⚠ WARNING

Flying objects

Do not place any objects (an umbrella, bag, etc.) between the front door and the front seat. They may become dangerous projectiles if the side airbag inflates.

⚠ WARNING

Do not attach objects

- Do not place any objects over the airbag or between the air bag and yourself. Do not attach any objects around the area the airbag inflates such as the door, side door glass, front and rear pillar.
- Do not put any objects between the side airbag label and seat cushion. It could cause harm if the vehicle is in a collision severe enough to deploy the airbags.
- Never place or insert any object into any small opening near side airbag labels attached to the vehicle seats. When the airbag deploys, the object may affect the deployment and result in an unexpected accident or injury.

- Do not install any accessories on the side or near the side airbags.

Curtain airbag

Curtain airbags are located along both sides of the roof rails above the front and rear doors.

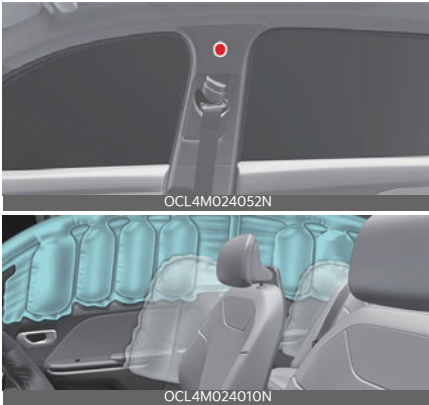

* The actual airbags in the vehicle may differ from the illustration.

They are designed to help protect occupants in certain side impacts and to help prevent them from ejecting out of the vehicle as a result of a rollover, especially when the seat belts are also in use.

- The curtain airbags are designed to deploy during certain side impact collisions, depending on the severity of impact. However, when the side deployment threshold is satisfied in a frontal impact, side airbags may deploy.
- The curtain airbags may deploy on the side of the impact or on both sides.
- The curtain airbags on both sides of the vehicle will deploy in certain rollover situations.

- The curtain airbags are not designed to deploy in all side impact or rollover situations.

Do not allow the passengers to lean their heads or bodies against the doors, put their arms on the doors, extend arms out of the window or place objects between the doors and passengers when they are seated on seats equipped with side airbags and/or curtain airbags.

* NOTICE

Never try to open or repair any components of the side and curtain airbag system. This should only be done by an authorized Kia dealer.

⚠ WARNING

Do not attach objects

- Do not place any objects over the airbag. Do not attach any objects around the area the airbag inflates such as the door, side door glass, front and rear pillar or roof side rail.
- Do not hang hard, breakable, or heavy objects on the coat hooks for safety reasons.

Airbag collision sensors

The airbag collision sensors are located in the following positions.

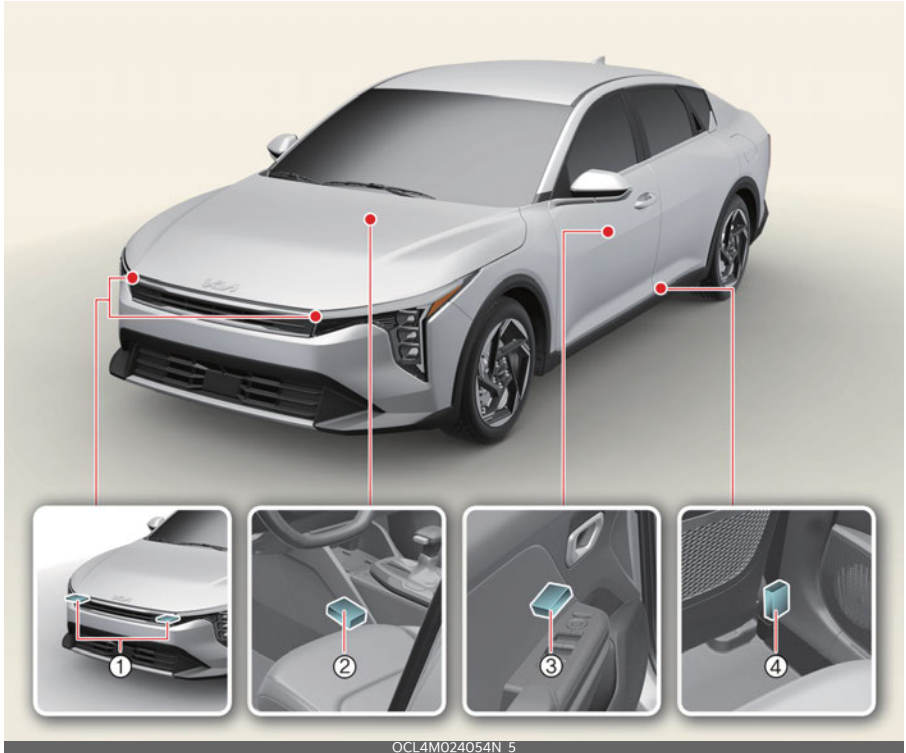

* The actual shape and position of sensors may differ from the illustration.

- 1 Front impact sensor
- 2 Supplemental Restraint System (SRS) control module/rollover sensor
- 3 Side pressure sensor
- 4 Side impact sensor

⚠ WARNING

Airbag sensors

- Do not hit or allow any objects to impact the locations where airbags or sensors are installed.

This may cause unexpected airbag deployment, which could result in serious personal injury or death.

- If the installation location or angle of the sensors is altered in any way, the airbags may deploy when they should not or they may not deploy when they should.

Do not try to perform maintenance on or around the airbag sensors. Have the vehicle checked and repaired by an authorized Kia dealer.

- Do not arbitrarily touch the front impact sensor. When the angle of the sensor is changed, the airbag system may malfunction.

Problems may arise if the sensor installation angles are changed due to the deformation of the front bumper, front end module, body or front doors where side collision sensors are installed. Have the vehicle checked and repaired by an authorized Kia dealer.

Installing bumper guards, side steps or running boards or replacing a bumper (or front door module) with non-genuine parts may adversely affect your vehicle's collision and airbag deployment performance.

Kia Genuine bumper guards/bumpers are guaranteed for quality and performance.

Why didn't my airbag go off in a collision? (Inflation and non-inflation conditions of the airbag)

There are many types of accidents in which the airbag would not be expected to provide additional protection.

These include rear impacts, second or third collisions in multiple impact accidents, as well as low speed impacts.

Airbag inflation conditions

Front airbags



Front airbags are designed to inflate in a frontal collision depending on several factors, including the severity of impact of the front collision.

Side and/or curtain airbags



* The actual airbags in the vehicle may differ from the illustration.

Side and/or curtain airbags are designed to inflate when an impact is detected by side collision sensors depending on several factors, including the severity of impact resulting from a side impact collision.

Also, the side and curtain airbags are designed to inflate when a rollover is detected by a rollover sensor.

Although the front airbags (driver's and front passenger's air bags) are primarily designed to inflate in frontal collisions, they may inflate in other types of collisions if the front impact sensors detect a sufficient frontal force in another type of impact.

Similarly, although side and curtain airbags are designed to inflate in certain side impact collisions, they may inflate in other types of collisions where a side force is detected by the sensors. In addition, side airbag and/or curtain airbags may inflate if rollover sensors indicate the possibility of a rollover occurring (even if none actually occurs) or in other situations, including when the vehicle is tilted while being towed.

Even if side and/or curtain airbags do not provide impact protection in a rollover, they will deploy to prevent ejection of occupants, especially those who are restrained with seat belts.

If the vehicle chassis is impacted by bumps or objects on unimproved roads, the airbags may deploy. Drive carefully on unimproved roads or on surfaces not designed for vehicle traffic to prevent unintended airbag deployment.

Airbag non-inflation conditions

- Airbags may not deploy in certain low-speed collisions where the airbag would not add any benefit beyond the protection already offered by the seat belts.



- Front airbags are not designed to inflate in rear collisions, because occupants are moved backward by the force of the impact. In this case, inflated airbags would not be able to provide any additional benefit.



- Front airbags may not inflate in side impact collisions, because passengers move in the direction of the collision. Thus, in side impacts, frontal airbag deployment would not provide additional occupant protection.



- In an angled collision, the force of impact may direct the occupants in a direction where the airbags would not

be able to provide any additional benefit, and thus the sensors may not deploy any air bags.



- Just before impact, drivers often brake heavily. Such heavy braking lowers the front portion of the vehicle causing it to "ride" under a vehicle with a higher ground clearance. Airbags may not inflate in this "under ride" situation because deceleration forces that are detected by sensors may be significantly reduced by such "under ride" collisions.



- Front airbags may not inflate in all rollover accidents when the SRS Control Module (SRSCM) indicates that the front airbag deployment would not provide additional occupant protection.



- Air bags may not inflate if the vehicle collides with an object such as a utility pole or tree. This is because the point

of impact is concentrated in one area and the full force of the impact is not delivered to the sensors.



Supplemental Restraint System (SRS) care

The Supplemental Restraint System (SRS) is virtually maintenance-free and so there are no parts you can safely service by yourself.

If the SRS airbag warning light does not appear, or continuously remains on, have your vehicle immediately inspected by an authorized Kia dealer.

Any work on the SRS, such as removing, installing, repairing, or any work on the steering wheel, the front passenger's panel, front seats and roof rails must be performed by an authorized Kia dealer. Improper handling of the SRS may result in serious personal injury.

For cleaning the airbag pad covers, use only a soft, dry cloth or one which has been moistened with plain water. Solvents or cleaners could adversely affect the airbag covers and proper deployment of the system.

If components of the airbag system must be discarded, or if the vehicle must be scrapped, certain safety precautions must be observed. An authorized Kia dealer knows these precautions and can give you the necessary information. Failure to follow these precautions and procedures could increase the risk of bodily injury.

⚠ WARNING**Tampering with SRS**

Do not tamper with or disconnect SRS wiring or other components of the SRS system. Doing so could result in the accidental inflation of the airbag or render the SRS inoperative.

⚠ WARNING**Towing vehicle**

Always have the ignition off when your vehicle is being towed. The side airbags may inflate if the vehicle is tilted such as when being towed because of the roll-over sensors in the vehicle.

Additional safety precautions

- **Never let passengers ride in the cargo area or on top of a folded-down back seat.** All occupants should sit upright, fully back in their seats with their seat belts on and their feet on the floor.
- **Passengers should not move out of or change seats while the vehicle is moving.** A passenger who is not wearing a seat belt during a crash or emergency stop can be thrown against the inside of the vehicle, against other occupants, or out of the vehicle.
- **Each seat belt is designed to restrain one occupant.** If more than one person uses the same seat belt, they could be seriously injured or killed in a collision.
- **Do not use any accessories on seat belts.** Devices claiming to improve occupant comfort or reposition the seat belt can reduce the protection provided by the seat belt and increase the chance of serious injury in a crash.
- **Passengers should not place hard or sharp objects between themselves and the airbags.** Carrying hard or sharp objects on your lap or in your mouth can result in injuries if an airbag inflates.
- **Keep occupants away from the airbag covers.** All occupants should sit upright, fully back in their seats with their seat belts on and their feet on the floor. If occupants are too close to the airbag covers, they could be injured if the airbags inflate.
- **Do not attach or place objects on or near the airbag covers.** Any object attached to or placed on the front or side airbag covers could interfere with the proper operation of the airbags.
- **Do not modify the front seats.** Modification of the front seats could interfere with the operation of the supplemental restraint system sensing components or side airbags.
- **Do not place items under the front seats.** Placing items under the front seats could interfere with the operation of the supplemental restraint system sensing components and wiring harnesses.
- **Never hold an infant or child on your lap.** The infant or child could be seriously injured or killed in the event of a crash. All infants and children should be properly restrained in appropriate child safety seats or seat belts in the rear seat.

⚠ WARNING

- Sitting improperly or out of position can cause occupants to be shifted too close to a deploying airbag, strike the interior structure or be thrown from the vehicle resulting in serious injury or death.

- Always sit upright with the seatback in an upright position, centered on the seat cushion with your seat belt on, legs comfortably extended and your feet on the floor.

Adding equipment to or modifying your air bag-equipped vehicle

If you modify your vehicle by changing your vehicle's frame, bumper system, front end or side sheet metal or ride height, this may affect the operation of your vehicle's airbag system.

Airbag warning label

Air bag warning labels, some required by the Canada Motor Vehicle Safety Standards (CMVSS), are attached to the sun visor to alert the driver and passengers of potential risks of the air bag system.



Keys	4-6
• Battery replacement	4-6
• Remote key	4-7
• Smart key.....	4-9
Immobilizer System	4-12
• Folding key immobilizer system	4-12
• Smart key immobilizer system	4-13
Theft-alarm system	4-14
Door locks	4-17
• With the smart key	4-17
• With the mechanical key.....	4-18
• Operating door locks from inside the vehicle	4-19
• Door lock/unlock features.....	4-21
• Child-protector rear door lock.....	4-21
• In case of an emergency	4-22
• Rear Occupant Alert (ROA) system	4-22
Digital Key 2	4-23
• Digital Key 2 (Smartphone).....	4-23
• Digital Key 2 (Card Key)	4-28
• Personalized Profile and Vehicle Settings	4-30
• Used Vehicle/Digital Key 2 Maintenance.....	4-33
• Limitations of the System.....	4-33
Integrated Memory System	4-34
• Storing memory positions	4-34
• Recalling memory positions	4-34
• Seat easy access.....	4-35
• Resetting the System	4-35
Trunk	4-36
• Opening the trunk	4-36
• Closing the trunk.....	4-37

4 Features of your vehicle

• Emergency trunk safety release	4-37
Smart Trunk.....	4-38
• How to use the Smart Trunk.....	4-38
• How to deactivate the Smart Trunk function using the smart key.....	4-40
• Detecting area	4-40
Windows	4-42
• Window opening and closing	4-43
• Power window lock button	4-45
• Remote window opening.....	4-45
Hood	4-46
• Opening the hood.....	4-46
• Hood open warning	4-47
• Closing the hood	4-47
Fuel filler door	4-48
• Opening the fuel filler door	4-48
• Closing the fuel filler door	4-49
Wide sunroof	4-52
• Power sunshade.....	4-52
• Tilt open/close	4-53
• Slide open/close	4-53
• Automatic reversal	4-53
• Resetting the sunroof.....	4-54
• Sunroof open warning.....	4-55
Steering wheel	4-55
• Motor Driven Power Steering (MDPS)	4-55
• Tilt & telescopic steering wheel	4-56
• Heated steering wheel.....	4-57
• Horn	4-58
Mirrors	4-58
• Inside rearview mirror	4-58

• Outside rearview mirror.....	4-59
Instrument cluster	4-62
• Adjusting instrument cluster illumination	4-63
• Gauges.....	4-63
• Transmission shift indicator	4-66
LCD display.....	4-67
• LCD display modes.....	4-67
• Other view modes.....	4-69
• Driver Assistance settings (infotainment system)	4-70
• LCD display messages.....	4-70
Warning and indicator lights	4-73
• Warning lights.....	4-73
• Indicator lights.....	4-79
Lighting.....	4-82
• Battery saver function.....	4-82
• Headlamp delay function.....	4-82
• Daytime Running Light (DRL).....	4-83
• Automatic Low beam light	4-83
• Lighting control	4-83
• Operating high beam	4-84
• Operating turn signals and lane change signals	4-85
• Operating front fog light	4-85
• High Beam Assist (HBA).....	4-86
Wipers and washers	4-88
• Operating windshield washers.....	4-89
• Heated washer nozzle.....	4-89
Welcome system	4-90
Interior lights.....	4-91
• Automatic turn off function	4-91
• Map lamp.....	4-91
• Room lamp.....	4-92

4 Features of your vehicle

• Luggage room lamp	4-92
• Vanity mirror lamp	4-92
Climate control system	4-93
• System operation	4-93
• Climate control air filter	4-94
• Air conditioning refrigerant label	4-95
• Checking the amount of air conditioner refrigerant and compressor lubricant	4-95
Manual climate control system	4-97
• Heating and air conditioning	4-98
Automatic climate control system	4-102
• Heating and air conditioning manually	4-103
• Air conditioning	4-109
Windshield defrosting and defogging	4-110
• Defogging Inside Windshield with manual climate control system	4-111
• Defrosting Outside Windshield with manual climate control system	4-111
• Defogging inside windshield with automatic climate control ...	4-111
• Defrosting outside windshield with automatic climate control ...	4-112
• Auto defogging system	4-112
• Defroster	4-113
• Defogging logic	4-113
• A/C Automatic Drying	4-114
Storage compartment	4-115
• Center console storage	4-115
• Glove box	4-115
• Luggage net holder	4-116
Interior features	4-116
• Cup holder	4-116
• Seat warmer	4-117

Features of your vehicle

- Air ventilation seat 4-118
- Sun visor..... 4-119
- USB charger 4-119
- Power outlet 4-120
- Wireless smartphone charging system..... 4-121
- Coat hook 4-122
- Floor mat anchor(s)..... 4-123
- Infotainment system 4-124**
 - Over-The-Air (OTA) Software Update 4-124
 - Antenna 4-126
 - USB port 4-126
 - AI Assistant..... 4-127
- Declaration of Conformity 4-127**

Features of your vehicle

Keys

⚠ WARNING

Never leave the keys in your vehicle with unsupervised children. Leaving children unattended in a vehicle with or a smart key is dangerous.

Children copy adults and they could press the start button. The key would enable children to operate power windows or other controls, or even make the vehicle move, which could result in serious bodily injury or death.

Record your key number



The key code number is stamped on the key code tag attached to the key set. Should

you lose your keys, this number will enable an authorized Kia dealer to duplicate the keys easily. Remove the key code tag and store it in a safe place. Record the key code number and keep it in a safe and handy place, but not in the vehicle.

⚠ WARNING

Aftermarket keys

Use only Kia original parts for the smart key in your vehicle. If an aftermarket key is used, the ignition switch or ENGINE START/STOP button may not return to ON after START. The starter will continue to operate causing possible fire due to excessive current in the wiring.

Battery replacement

The smart key uses a 3 volt lithium battery which will normally last for several years.



If you are unsure how to use or replace the battery, contact an authorized Kia dealer.

1. Pry open the key battery cover gently using a thin tool.
2. Replace the battery with a new battery. When replacing the battery, make sure the battery position.
 - Folding key: CR2032
 - Smart key: CR2450
3. Install the battery in the reverse order of removal.

For smart key replacement, visit an authorized Kia dealer.

The smart key is designed to give you years of use, but it can malfunction if exposed to moisture or static electricity. If you are unsure how to use or replace the battery, contact an authorized Kia dealer.

Using the wrong battery can cause the smart key to malfunction. Be sure to use the correct battery.



An inappropriately disposed battery can be harmful to the environment and human health. Dispose the battery

according to your local law(s) or regulation.

⚠ WARNING

THIS PRODUCT CONTAINS A BUT-TON BATTERY

If swallowed, a lithium button battery can cause severe or fatal injuries within 2 hours.

Keep batteries out of reach of children.

If you think batteries may have been swallowed or placed inside any part of the body, seek immediate medical attention.

⚠ CAUTION

Smart key damage

The smart key can malfunction if dropped, exposed to moisture, static electricity, heat or direct sunlight.

⚠ WARNING

IC WARNING

This device complies with Industry Canada licence-exempt RSS standard(s). Operation is subject to the following two conditions:

1. This device may not cause interference, and
2. This device must accept any interference, including interference that may cause undesired operation of the device.

This device complies with Industry Canada licence-exempt RSS standard(s).

Operation is subject to the following two conditions:

1. This device may not cause interference, and

2. This device must accept any interference, including interference that may cause undesired operation of the device.

*** NOTICE**

Changes or modifications not expressly approved by the party responsible for compliance could void the user's authority to operate the equipment. If the smart key is inoperative due to changes or modifications not expressly approved by the party responsible for compliance, it will not be covered by your manufacturer's vehicle warranty.

Remote key (if equipped)

With a remote key, you can lock or unlock the door and trunk.



Lock (1)

All doors are locked if the lock button is pressed. If all doors are closed, the hazard warning lights will blink and the chime will sound once to indicate that all doors are locked.

Also, if the lock button is pressed once more within 4 seconds, the hazard warning lights will blink and the chime will sound once to confirm that the door is locked.

However, if any door remains open, the hazard warning lights (and/or the chime) will not operate. But if all doors are closed after the lock button is pressed, the hazard warning lights will blink once.

Unlock (2)

The driver's door is unlocked if the unlock button is pressed once. The hazard warning lights will blink twice to indicate that the driver's door is unlocked.

All doors are unlocked if the unlock button is pressed once more within 4 seconds. The hazard warning lights will blink and the chime will sound twice again to indicate that all doors are unlocked. After pressing this button, the doors will lock automatically unless you open any door within 30 seconds.

If you attempt to lock or unlock the door by pressing the door lock/unlock button in any of the following states, the door will not be locked or unlocked.

- When you want to lock or unlock the door in the ACC or ON state.
- When you want to lock a door in a car with one or more doors open.

Depending on the vehicle, the driver can turn off or set the 2-press unlock setting function.

* NOTICE

If the remote key is inoperative due to exposure to water or liquids, it will not be covered by your manufacturer's vehicle warranty.

Trunk unlock (3)

If you press this button for longer than a second, the lock will be released. Once the trunk is opened and then closed, the trunk will lock automatically.

Panic alarm (4)

The horn sounds and the hazard warning lights blink for about 30 seconds if this button is pressed for more than 0.5

seconds. To stop the horn and lights, press any button on the transmitter.

Mechanical key

If the remote key does not operate normally, you can lock or unlock the door by using the mechanical key.



To unfold the key, press the release button then the key will unfold automatically.

To fold the key, fold the key manually while pressing the release button.

⚠ CAUTION

Key button operation

Do not fold the key without pressing the release button. This may damage the key.

Transmitter precautions

The transmitter will not work if any of the following occurs:

- The ignition key is in the ignition switch.
- You exceed the operating distance limit. (about 10 m [32 ft]).
- The battery in the transmitter is weak.
- Other vehicles or objects may be blocking the signal.
- The weather is extremely cold.
- The remote key is close to a radio transmitter such as a radio station or an airport which can interfere with normal operation of the transmitter.

When the transmitter does not work properly, open and close the door with the ignition key. If you have a problem with the remote key, contact an authorized Kia dealer.

- If the transmitter is in close proximity to your cell phone or smart phone, the signal from the transmitter could be blocked by normal operation of your cell phone or smart phone. This is especially important when the phone is active such as making calls, receiving calls, text messaging, and/or sending/receiving emails. Avoid placing the remote key and your cell phone or smart phone in the same pants or jacket pocket and maintain adequate distance between the two devices.

⚠ CAUTION

Transmitter

Keep the transmitter away from water or any liquid as, it can become damaged and not function properly.

* NOTICE

If the remote key is inoperative due to exposure to water or liquids, it will not be covered by your manufacturer's vehicle warranty.

Smart key (if equipped)

With a smart key, you can lock or unlock a door (and trunk) and even start the engine without inserting the key.



Lock (1)

All doors are locked if the lock button is pressed. If all doors are closed, the hazard warning lights will blink and the chime will sound once to indicate that all doors are locked.

If the lock button is pressed again within 4 seconds, the hazard warning lights will blink and the chime will sound once to confirm that the door is locked.

If any door remains open, the hazard warning lights (and/or the chime) will not operate. But if all doors are closed after the lock button is pressed, the hazard warning lights will blink once.

Unlock (2)

The driver's door is unlocked if the unlock button is pressed once. The hazard warning lights will blink twice to indicate that the driver's door is unlocked.

All doors are unlocked if the unlock button is pressed once more within 4 seconds. The hazard warning lights will blink and the chime will sound twice again to indicate that all doors are unlocked. After pressing this button, the doors will lock automatically unless you open any door within 30 seconds.

If you attempt to lock or unlock the door by pressing the door lock/unlock button in any of the following states, the door will not be locked or unlocked.

- When you want to lock or unlock the door in the ACC or ON state.
- When you want to lock a door in a car with one or more doors open.

For some vehicles, you can remove or set the 2-press unlock (press it twice to unlock).

*** NOTICE**

- You can activate or deactivate the 2-press unlock function on the infotainment system screen.
- If the smart key is inoperative due to exposure to water or liquids, it will not be covered by your manufacturer's vehicle warranty.

*** INFORMATION**

The infotainment system may change after software updates. For more information, refer to the user's manual provided in the infotainment system and the quick reference guide.

Trunk open  (3)

If you press this button for longer than a second, the trunk lid will be opened.

Once the trunk lid is opened and then closed, the trunk lid will lock automatically.

Panic alarm  (4)

The horn sounds and the hazard warning lights blink for about 30 seconds if this button is pressed for more than 0.5 seconds. To stop the horn and lights, press any button on the transmitter.

Remote start  (5) (if equipped)

You can start the vehicle using the Remote Start button (5) on the smart key.

To start the vehicle remotely:

1. Press the door lock button on the smart key within 10 m. (32 ft) from the vehicle.

2. Press the Remote Start button (5) for more than 2 seconds within 4 seconds after pressing the door lock button. The engine will start.
3. To turn off the remote start function, press the Remote Start button (5) once.

*** NOTICE**

- The vehicle must be in P (Park) for the remote start function to start.
- The engine turns off if you enter the vehicle without a registered smart key. If you enter the vehicle without the smart key while the car is starting remotely, **Carry your key to keep the ignition on** is displayed.
- The engine turns off if you do not get on the vehicle within 10 minutes after remotely starting the vehicle.
- The engine turns off if you do not get on the vehicle within 10 minutes after remotely starting the vehicle.
- The Remote Start button (5) may not operate if the smart key is not within 10 m. (32 ft).
- The vehicle will not remotely start if the engine hood or trunk is opened.
- Do not idle the engine for a long period.
- Do not operate remote start in closed areas where there is no adequate ventilation for the engine exhaust.

Start-up (if equipped)

You can start the vehicle without inserting the key.

* For more information, refer to "ENGINE START/STOP button (if equipped)" on page 5-7.

Mechanical key

If the smart key does not operate normally, you can lock or unlock the door by using the mechanical key.

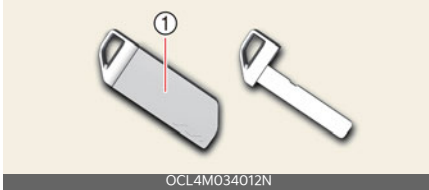

Pull the mechanical key from the protective cover (1).

Smart key precautions

The smart key may not operate if any of the following occur:

- The smart key is close to a radio transmitter such as a radio station or an airport which can interfere with normal operation of the smart key.
- The smart key is near a mobile two-way radio system or a cellular phone.
- Another vehicle's smart key is being operated close to your vehicle.

Tinting the vehicle windows with film, especially metalized film, may interfere with receiving frequency transmitted by the smart key, reducing its operating range.

When the smart key does not work correctly, open and close the door with the mechanical key and contact an authorized Kia dealer.

If the smart key is near your cellular phone or smartphone, the signal from the smart key could be blocked by normal operation of your cell phone or smartphone. This is especially important when the phone is active, such as when making calls, receiving calls, text messaging, and/or sending/receiving emails.

Avoid placing the smart key and your cell phone or smartphone in the same pants or jacket pocket and maintain adequate distance between the two devices.

⚠ CAUTION

Transmitter

Keep the transmitter away from water or any liquid, as it can become damaged and not function properly.

* NOTICE

• Loss of the smart key

A maximum of 2 smart keys can be registered to a single vehicle.

If you happen to lose your smart key, you will not be able to start the vehicle. You should immediately take the vehicle and remaining key to your authorized Kia dealer (tow the vehicle, if necessary) to protect it from potential theft.

- If the smart key is inoperative due to exposure to water or liquids, it will not be covered by your manufacturer's vehicle warranty.
- To prevent the electronic key from becoming damaged by magnetic fields, do not leave it near the following electrical appliances:
 - TVs
 - Personal computers
 - Cellular phones, cordless phones and battery chargers
 - Table lamps
 - Induction cookers
- If you must leave the vehicle's key with a parking attendant, remove the mechanical key for your own use and provide the attendant with the electronic key only.

- When bringing a smart key onto an airplane, make sure you do not press any button on the key while inside the cabin. If you are carrying the key in your bag etc., make sure that the buttons cannot be pressed accidentally. If you press a button, the key may emit radio waves that could interfere with the operation of the aircraft.
 - If the smart key is not moved for some time, the detection function for smart key operation will pause. Lift the smart key to activate the detection again. (if equipped)
-

Immobilizer System

Folding key immobilizer system

Your immobilizer system is comprised of a small transponder in the ignition key and electronic devices inside the vehicle. With the immobilizer system, whenever you insert your ignition key into the ignition switch and turn it to ON, it checks and determines and verifies that the ignition key is valid.

If the key is determined to be valid, the engine will start.

If the key is determined to be invalid, the engine will not start.

Deactivating the immobilizer system

Insert the ignition key into the key cylinder and turn it to the ON position.

Activating the immobilizer system

Turn the ignition key to the OFF position. The immobilizer system activates automatically. Without a valid ignition key for your vehicle, the engine will not start.

Your Immobilizer password is a customer unique password and should be kept confidential. Do not leave this number anywhere in your vehicle.

* NOTICE

Keep each key separately in order to avoid a starting malfunction.

* NOTICE

In order to prevent theft of your vehicle, do not leave spare keys anywhere in your vehicle. Your immobilizer password is a customer unique password should

be kept confidential. Do not leave this number anywhere in your vehicle.

* NOTICE

- Do not put metal accessories near the ignition switch.
- Metal accessories may interrupt the transponder signal and may prevent the engine from being started.

* NOTICE

If you need additional keys or lose your keys, consult an authorized Kia dealer.

⚠ CAUTION

Immobilizer damage

Do not expose your immobilizer system to moisture, static electricity or rough handling. This may damage your immobilizer.

Limp home (override) procedure (if equipped)

When you turn the ignition switch to the ON position, if the immobilizer indicator () goes off after blinking 5 times, your transponder equipped in the ignition key is out of order. You cannot start the engine without the limp home procedure. To start the engine, you have to input your password by using the ignition switch. Your password is only available from an authorized Kia dealership. Contact an authorized dealer for more information.

The following procedure is how to input your password:

1. Turn the ignition switch to the ON position. The immobilizer indicator () will blink 5 times and go off

indicating the beginning of the limp home procedure.

2. Turn the ignition switch to the ACC position.
3. To enter the first digit (in this example "2"), turn the ignition switch to the ON and ACC position twice. Perform the same procedure for the next digits between 3 seconds and 10 seconds (for example, for "3", turn the ignition ON and ACC 3 times).
4. If all of the digits have been input successfully, you have to start the engine within 30 seconds. If you attempt to start the engine after 30 seconds, the engine will not start and you will have to input your password again.

After performing the limp home procedure, you have to see an authorized Kia dealer immediately to inspect and repair your ignition key or immobilizer system.

Smart key immobilizer system

The immobilizer system protects your vehicle from theft. If an improperly coded key (or other device) is used, the vehicle's power system is disabled.

When the ENGINE START/STOP button is placed in the ON position, the immobilizer system indicator should come on briefly, then go off. If the indicator starts to blink, the system does not recognize the coding of the key.

Place the ENGINE START/STOP button in the OFF position, then place the ENGINE START/STOP button in the ON position again.

If the system repeatedly does not recognize the coding of the key, contact your Kia dealer.

Do not attempt to alter this system or add other devices to it. Electrical prob-

lems could result that may make your vehicle inoperable.

*** NOTICE**

When starting the vehicle, do not use the key with other immobilizer keys around. Otherwise, the vehicle may not start or may stop soon after it starts. Keep each key separate to avoid a starting malfunction.

*** NOTICE**

If you need additional keys or lose your keys, contact an authorized Kia dealer.

This device complies with Industry Canada licence-exempt RSS standard(s).

Operation is subject to the following two conditions:

1. This device may not cause interference, and
2. This device must accept any interference, including interference that may cause undesired operation of the device.

*** NOTICE**

Changes or modifications not expressly approved by the party responsible for compliance could void the user's authority to operate the equipment. If the smart key is inoperative due to changes or modifications not expressly approved by the party responsible for compliance, it will not be covered by your manufacturer's vehicle warranty.

Theft-alarm system

This system is designed to provide protection from unauthorized entry into the vehicle.

This system is operated in three stages:

- 1 Disarmed stage
- 2 Armed stage
- 3 Theft-alarm stage

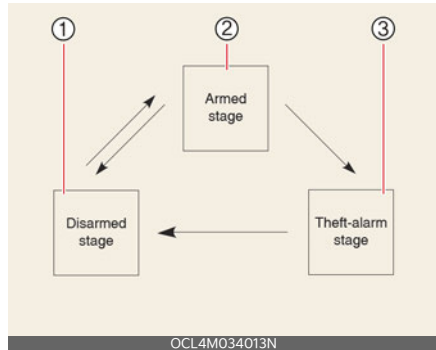

This system is operated in three stages: the first is the "Armed" stage, the second is the "Theft-alarm" stage, and the third is the "Disarmed" stage. If triggered, the system provides an audible alarm with blinking of the hazard warning lights.

⚠ CAUTION

Do not attempt to alter this system or add other devices to it.

Armed stage

Using the smart key

Park the vehicle and stop the engine. Arm the system as described below.

1. Turn off the engine.
2. Make sure that all doors, the hood and trunk are closed and latched.
3. Lock the doors by pressing the button of the front outside door handle with

the smart key in your possession.

After completion of the steps above, the hazard warning lights will operate once to indicate that the system is armed. If any door (or trunk) or hood remains open, the hazard warning lights and the chime will not operate and the theft-alarm will not arm. If all doors and trunk and hood are closed after the lock button is pressed, the hazard warning lights blink once. The system can also be armed by locking the doors with the key from the front doors. The hazard warning lights will not blink using this method.

4. Lock the doors by pressing the lock button on the smart key. After completion of the steps above, the hazard warning lights will operate once to indicate that the system is armed.

Using the folding key

Park the vehicle and stop the engine. Arm the system as described below.

1. Turn off the engine and remove the ignition key from the ignition switch.
2. Make sure that all doors (and trunk) and the engine hood are closed and latched.
3. Lock the doors by pressing the lock button on the folding key.

After completion of the steps above, the hazard warning lights will blink once to indicate that the system is armed. If any door (and trunk) or engine hood remains open, the hazard warning lights won't operate and theft-alarm will not arm. After this, if all doors (and trunk) and engine hood are closed, the hazard warning lights blink once.

* NOTICE

The theft-alarm system can be deactivated by an authorized Kia dealer.

If you want this feature, consult an authorized Kia dealer.

* NOTICE

Do not arm the system until all passengers have left the vehicle. If the system is armed while a passenger(s) remains in the vehicle, the alarm may be activated when the remaining passenger(s) leaves the vehicle. If any door (or trunk) or hood is opened within 30 seconds after the system enters the armed stage, the system will be disarmed to prevent unnecessary alarm.

Theft-alarm stage

The alarm will be activated if any of the following occurs while the system is armed.

- A front or rear door is opened without using the smart key.
- The trunk is opened without using the smart key.
- The hood is opened.

The horn will sound and the hazard warning lights will blink continuously for approximately 27 seconds, and the horn will sound 3 times unless the system is disarmed. To turn off the system, unlock the doors with the smart key.

Disarmed stage

The system will disarm when:

Smart key

- The door unlock button is pressed.
- The button of the front outside door is pressed while carrying the smart key.
- The engine is started. (within 3 seconds)

After pressing the unlock button, the hazard warning lights will blink and the chime will sound twice (in smart key) to indicate that the system is disarmed.

After pressing the unlock button, if any door (or trunk) is not opened within 30 seconds, the system will be rearmed.

Folding key

- The door unlock button is pressed.
- The engine is started. (within 3 seconds)
- The ignition switch is in the "ON" position for 30 seconds or more.

* NOTICE

- Avoid trying to start the engine while the alarm is activated. The vehicle starting motor is disabled during the theft-alarm stage.

If the vehicle is not disarmed with the smart key, open the doors by using the mechanical key and start the engine by directly pressing the ENGINE START/STOP button with the smart key to the ON position and wait for 30 seconds. Then the system be disarmed.

- If you lose your keys, consult your authorized Kia dealer.

⚠ CAUTION

Adjusting alarm system

Do not change, alter or adjust the theft alarm system in your vehicle. Improper installation of the alarm system could damage the vehicle or cause the system to malfunction.

* NOTICE

Malfunctions caused by improper alterations, adjustments or modifications to the theft-alarm system are not covered by your vehicle manufacturer warranty.

Door locks

Know how to use the door lock so that you can lock or unlock the door if necessary.

With the smart key

Button type



Touch sensor type



Carrying the smart key, you may lock and unlock the vehicle doors (and trunk) and start the engine. Refer to the following for more details.

Locking

Pressing the button or touching the sensor of the front outside door handles with all doors (and trunk) closed and any door unlocked, locks all the doors (and trunk). If all doors and engine hood are closed, the hazard warning lights will blink once to indicate that all doors are locked.

The button/sensor will only operate when the smart key is within 0.7-1 m (28-40 inches) from the front door handle. If you want to make sure that a door has locked or not, you should pull the front door handle.

Even though you press the front door handle button/sensor, the doors will not lock and the chime will sound for a few seconds if any of following occur:

- The smart key is in the vehicle.
- The ENGINE START/STOP button is in the ACC or ON position.
- Any door except the trunk is open.

Unlocking

Pressing the button or touching the sensor of the front outside door handles, or the hand is detected in the door handle pocket, with all doors (and trunk) closed and locked, unlocks all the doors (and trunk). The hazard warning lights blink twice to indicate that all doors are unlocked.

The button/sensor will only operate when the smart key is within 0.7-1 m (28-40 inches) from the front door handle.

When the smart key is recognized within 0.7-1 m (28-40 inches) from the front door handle, other people can also open the door without possession of the smart key.

After pressing the button/sensor, the doors will lock automatically unless you open any door within 30 seconds.

When the 2-press unlock function is activated:

- If you press the Door Unlock button on the smart key, the driver's door will unlock.
- If you press the Door Unlock button on the smart key within four seconds again, then all the doors will unlock.
- If you press the driver's outside door handle button, the driver's door will unlock.

- If you press the driver's outside door handle button within four seconds again, then all the doors will unlock.

*** NOTICE**

You can activate or deactivate the 2-press unlock function on the infotainment system screen.

*** INFORMATION**

The infotainment system may change after software updates. For more information, refer to the user's manual provided in the infotainment system and the quick reference guide.

With the mechanical key



If you lock the driver's door with a mechanical key, the driver's door will lock. If you unlock the driver's door with a mechanical key, you can open and close the driver's door only.

1. Pull out the door handle.
 2. Press the lever located inside the bottom part of the cover with a key or flat-head screwdriver.
 3. Push out the cover while pressing the lever.
 4. Turn the key toward the rear of the vehicle to unlock and toward the front of the vehicle to lock.
- Driver's door can also be locked and unlocked with the transmitter.

- Once the driver's door is unlocked, it may be opened by pulling the door handle.
- When closing the driver's door, push the door by hand. Make sure the driver's door is closed securely.

*** NOTICE**

- Be careful when locking the door by mechanical key operation, only the driver's door can be locked/unlocked.
- When all doors are locked with the mechanical key, lock all doors by using the central door lock button inside the vehicle. Open the door using the driver's inner door handle, and then close the door and lock the driver's door with mechanical key operation.
- Refer to "With central door lock button" on page 4-20 to lock from inside the vehicle.

*** NOTICE**

- When removing the cover, be careful not to lose cover and any scratches.
- When the key cover freezes and does not open, lightly tap or indirectly warm (hand temperature, etc.) it.
- Do not apply excessive force to the door and door handle. It may be damaged.

*** NOTICE**

- In cold and wet climates, door lock and door mechanisms may not work properly due to freezing conditions.
- If the door is locked/unlocked multiple times in rapid succession with either the vehicle key or door lock switch, the system may stop operating temporarily in order to protect the circuit

and prevent damage to system components.

⚠ WARNING

- Securely close your door before you begin driving. Failure to fully close your door may cause it to be opened during vehicle operation.
- Keep your body out of the way of the closing door to prevent injuries.

⚠ WARNING

If any passengers must remain in the vehicle while it is very hot or cold outside, there is risk of injuries or danger to life. Do not lock the vehicle from the outside when there are passengers in the vehicle.

⚠ CAUTION

Do not unnecessarily open and close the door repeatedly or with excessive force. Such action can damage the vehicle door.

*** NOTICE**

Always place the ignition switch or ENGINE START/STOP button in the OFF position, engage the parking brake, close all windows, and lock all doors when leaving your vehicle unattended.

- If you lock the door with the central door lock button, all vehicle doors will lock automatically.

*** NOTICE**

Always turn off the vehicle, engage the parking brake, close all windows, and lock all doors when leaving your vehicle unattended.

Operating door locks from inside the vehicle

You can operate door locks with the central door lock button.

With the door handle



- **Front door**
If the inner door handle is pulled when the door is locked, the door will unlock and open.
- **Rear door**
If the inner door handle is pulled once when the door is locked, the door will unlock.
If the inner door handle is pulled again, the door will open.

Door lock malfunction

If a power door lock ever fails to function while you are in the vehicle, try one or more of the following techniques to exit:

- Operate the door unlock feature repeatedly (both electronic and manual) while simultaneously pulling on the door handle.
- Lower a front window and use the key to unlock the door from outside.
- Move to the cargo area and open the trunk.

⚠ WARNING

Do not pull the inner door handle of driver's (or passenger's) door while the vehicle is moving. Doing so can distract the driver or cause an occupant ejection.

With central door lock button

Driver side



Passenger side

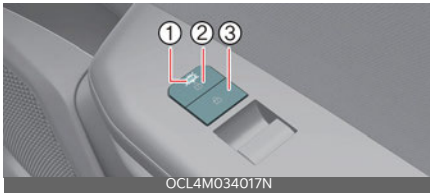

1 Doors indicating light

2 Door Unlock

3 Door Lock

Operate by pressing the central door lock button.

- To lock all vehicle doors, press the central door lock button (3) of driver and passenger side.
- To unlock all vehicle doors, press central door unlock button (2) of driver and passenger side.

When all vehicle doors are locked, the indicating lights (1) on the driver's door and passenger's door will turn off. If any door is unlocked, it would turn on.

If any door is opened, the doors will not lock even though the central door lock button is pressed.

⚠ WARNING

Doors

- The doors should always be fully closed and locked while the vehicle is in motion to prevent accidental opening of the door. Locked doors will also

discourage potential intruders when the vehicle stops or slows down.

- Be careful when opening doors and watch out for vehicles, motorcycles, bicycles or pedestrians approaching the vehicle in the path of the door. Opening a door when something is approaching can result in an accident and cause vehicle damage or serious injury.

*** NOTICE**

Unlocked vehicles

Leaving your vehicle unlocked can increase the risk of vehicle theft or any possible criminal harm caused by someone hiding in your vehicle while you are gone. Always turn off the vehicle, engage the parking brake, close all windows and lock all doors when leaving your vehicle unattended.

⚠ WARNING

Unattended children, the elderly or pets

An enclosed vehicle can become extremely hot, causing death or severe injury such as heatstroke to unattended children, the elderly or pets who cannot escape the vehicle. When left or trapped in a hot vehicle, make sure to stay hydrated and avoid sun exposure through the vehicle's windshield. Furthermore, children might operate features of the vehicle that could injure them, or they could encounter other harm, possibly from someone gaining entry to the vehicle. Never leave children or animals unattended in your vehicle.

Door lock/unlock features (if equipped)

The vehicle is equipped with door lock/unlock features for the safety and convenience of passengers.

Impact sensing door unlock system

All doors will automatically unlock when an impact causes the airbags to deploy.

Auto unlock on shift to P

When this feature is set in the infotainment system screen, all the doors will be unlocked automatically when the vehicle is shifted back into P (Park) while the vehicle is ON.

Speed sensing door lock system

All doors will automatically lock after the vehicle speed exceeds 15 km/h (10 mph).

You can activate or deactivate the auto door lock/unlock features in the vehicle.

Auto unlock vehicle off

When this feature is set in the cluster or infotainment system screen, all the doors will be unlocked automatically when the vehicle is turned off.

Auto lock enable on shift

When this feature is set in the cluster or infotainment system screen, all the doors will be locked automatically when the vehicle is shifted out of P (Park) while the vehicle is running.

Child-protector rear door lock

The child safety lock is provided to help prevent children from accidentally opening the rear doors from inside the vehicle.

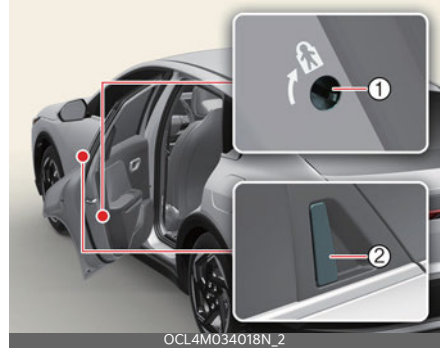

The rear door safety locks should be used whenever children are in the vehicle.

The child safety lock is located on the edge of each rear door (1). When the child safety lock is in the lock position, the rear door will not open if the inner door handle is pulled.

To lock the child safety lock, insert a key (or screwdriver) into the hole and turn it to the lock position.

To allow a rear door to be opened from inside the vehicle, unlock the child safety lock.

To open the rear door, pull the outside door handle (2).

⚠ WARNING

Rear door locks

If children accidentally open the rear doors while the vehicle is in motion, they could fall out and be severely injured or killed. To prevent children from opening the rear doors from the inside, the rear

door safety locks should be used whenever children are in the vehicle.

In case of an emergency

If the electrical power door lock switch is not operating (e.g., dead car battery) the only way to lock the door(s) is with the mechanical key from the outside keyhole.

Doors without an outside keyhole can be locked as follows:

1. Open the door.
2. Insert the key into the emergency door lock hole and turn the key to the lock position as shown.



3. Close the door securely.

* NOTICE

If the electrical power to the door lock switch is not operating (e.g., dead car battery) and the trunk is closed, you will not be able to open the trunk until power is restored.

Rear Occupant Alert (ROA) system

The is provided to help prevent exiting the vehicle with a rear passenger left in the vehicle.

- When you open the front door after opening and closing the rear door and turning off the engine, the warning message appears on the cluster.

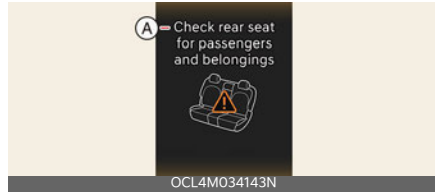

A: Check rear seat for passengers and belongings

You can activate or deactivate the ROA from the infotainment system screen.

The option can be found under the following menu:

1. Press the **SETUP** button of the infotainment system.
2. Press **Setup** → **Vehicle** → **Convenience** → **Rear Occupant Alert** on the infotainment system screen.

* INFORMATION

The infotainment system may change after software updates. For more information, refer to the user's manual provided in the infotainment system and the quick reference guide.

* NOTICE

The does not actually detect objects or people in the rear seat. By using a rear door opened and closed history, the system informs the driver that there may be something in the rear seat.

* NOTICE

The uses a rear door opened and closed history.

The history is reset after the driver turns off ignition normally, gets out of the vehicle and locks the door remotely using the remote keyless entry. Even if a rear door does not reopen, the ROA system alert can occur.

For example, after the ROA alert occurs, if the driver does not lock the door and drives again, the alert can occur.

WARNING

The door lock system may not work if the electrical system is compromised. Train children how to open the car door manually before an emergency situation arises. That way, they would be able to open the door manually in the event of an emergency.

Digital Key 2 (if equipped)

Kia Digital Key 2 provides convenience to the driver, such as locking or unlocking the driver and passenger doors or the trunk and turning on the vehicle with a smartphone or card key, without a smart key.

Digital Key 2 (Smartphone)

How to register Digital Key 2 (Smartphone)

Kia Digital Key 2 can only be used on the smartphones that support this function, and the smartphone's Digital Key 2 function is provided by the smartphone manufacturer. Some smartphone functions may be incompatible with your vehicle. While updating the digital key 2 controller, the smart key function may not work temporarily. In this case, it can be operated with the door lock/unlock button of the smart key.

Smartphone Set Up

To use Digital Key 2 (Smartphone) function, install the Kia Connect App on your smartphone, register your information and subscribe to the service.

Smartphone Registration



1 Smartphone key

2 My Smartphone key

3 Save

1. Turn the vehicle on with the Smart key and make sure to keep the smart

key inside the vehicle during digital key registration.

2. After pressing **Digital Key Settings** → **Register** on Kia Connect App, place the backside of the smartphone on the in-vehicle charging pad.



1) Charging pad

- If the device is supported from additional vehicle services, the Digital Key can be registered wirelessly.
3. Select **Save** menu on the instrument cluster or on the infotainment system screen. The saving process will begin automatically.
 4. When the digital key (smartphone) is saved, a message will appear on the instrument cluster or the infotainment system screen.
 5. Remove the smartphone from the in-vehicle authentication pad (wireless charging pad) and complete the saving process by following the instructions on the smartphone screen.

*** INFORMATION**

- The infotainment system may change after software updates. For more information, refer to the user's manual provided in the infotainment system and the quick reference guide.
- Vehicle

When there is a digital key (smartphone) already saved in the vehicle, Delete All will be displayed on the Smartphone Key menu screen of the infotainment system and Delete will

be displayed on the My Smartphone Key screen. If you want to save a digital key again, refer to "How to delete Digital Key (Smartphone)" on page 4-27.

- Smartphone

The digital key cannot be saved again while the vehicle's digital key is saved in the owner's smartphone. Save the digital key after deleting the digital key from the smartphone OEM wallet App or in the vehicle.

- During the digital key 2 saving process, the process will cancel when:
 - The smartphone is removed from the in-vehicle authentication pad (wireless charging pad)
 - Changing the infotainment system or instrument cluster screen
 - The vehicle is turned off
 - The gear is shifted
 - There is no smart key (saving process will not begin)
- As the in-vehicle authentication pad may not work smoothly depending on the internal structure of the smartphones, the digital key may not be registered. Register the key by moving the smartphone to the left or right of the in-vehicle authentication pad (wireless charging pad).
- UWB (Ultra Wide Band) means ultra-wideband wireless communication technology. NFC (Near Field Communication) means short-range wireless communication.

How to Use the Digital Key 2 (Smartphone)

Smartphone Touch Control

The driver can lock and unlock the door by touching the smartphone on the door handle without opening the Kia Connect App. The vehicle can be started by placing the smartphone on the charging pad. Make sure that the location of the smartphone's NFC antenna touches the door handle authentication pad.



- 1 Door handle authentication pad
- 2 Different smartphones have their NFC antennas located in different places.

The Apple iPhone's NFC antenna is located at the top of the back of the device, and the Apple Watch's NFC antenna is in the center of the screen. The NFC antenna is in the same location that you may use for tapping to make contactless payments. If you are uncertain about the location of the NFC antenna on your phone, contact your smartphone manufacturer for more details.

Locking/Unlocking the doors

- If the driver touches the smartphone antenna to the driver's or passenger's door handle authentication pad for more than 2 seconds, the door will lock or unlock.

- After unlocking the doors, the doors will automatically re-lock after 30 seconds unless a door is opened.
- If the smartphone digital key does not operate, move the smartphone more than 0.1 m (4 inches) from the door handle authentication pad and try it again.

For smartphones without UWB support:

To lock or unlock the doors with a registered smartphone, touch the NFC antenna on the smartphone on the authentication pad of the driver's or passenger's outside door handle for about 2 seconds.

For smartphones with UWB support:

To lock or unlock the doors, carry your smartphone and touch the door handle lock/unlock sensor (curved area) on the outside door handle.

⚠ WARNING

- If the smartphone is in a back pocket or bag, the signal may be blocked and could limit the Bluetooth connection and cause operation delay when locking/unlocking doors or starting the vehicle.
- If a tinting film containing metal components is applied, the digital key may not function properly.

*** NOTICE**

Note that the door will unlock and a beep sounds when using the Digital Key 2 if any of the following occur:

- When the Smart Key is in the vehicle

- The ENGINE START/STOP button is in ACC or ON position
- Attempting to lock the door when more than one door, or hood, trunk is opened
- If a tinting film containing metal substances is applied to the digital key, it may not function properly.

Starting the vehicle

After placing your registered smartphone on the charging pad, depress the brake pedal and press the ENGINE START/STOP button.

- Once the vehicle is started, you can remove the smartphone from the pad.

For more details, refer to "ENGINE START/STOP button (if equipped)" on page 5-7.

For smartphones without UWB support:

- Place the NFC antenna of the smartphone in of the charging pad, press the brake pedal, and then press the start button to start the vehicle.
- After starting the vehicle, you can remove the smartphone from the charging pad.
- Some smartphones may not have smooth NFC communication due to their internal structure. In such cases, move the smartphone to the right or left of the charging pad to operate it.
- The Apple iPhone's NFC antenna is located at the top of the back of the device, and the Apple Watch's NFC antenna is in the center of the screen. The NFC antenna is in the same location that you may use for tapping to make contactless payments. If you are

uncertain about the location of the NFC antenna on your phone, contact your smartphone manufacturer for more details.

For smartphones with UWB support:

- Carry the smartphone inside the vehicle, press the brake pedal, and then press the start button to start the vehicle.
- To start the vehicle remotely, use an app provided by the smartphone manufacturer to lock the vehicle using the door lock button, and then press the remote start button within 4 seconds. The vehicle will start, and the hazard warning light will flash
- To turn off the vehicle, press the remote start button again.

Operating the trunk

For smartphones with UWB support:

- When the vehicle is locked, to open the trunk, press the trunk open button, carrying a smartphone.
- When Smart trunk is selected, the trunk automatically opens when you approach the detecting area behind the trunk for more than 3 seconds, carrying a smartphone with Digital Key 2 registered.

WARNING

The vehicle can be started when the registered smartphone is placed on the in-vehicle authentication pad (wireless charging pad). Therefore, do not leave unsupervised children or people who are not aware of the system since it can result in serious injury or death. In addi-

tion, always have the registered smartphone with you to prevent vehicle theft when leaving the vehicle.

*** NOTICE**

The operation time of Digital Key 2 for shared user may extend during first time use.

Approach your Digital Key 2 (smartphone) on the authentication pad located in the outside door handle until the vehicle door lock/unlock function operates.

If the inner authentication pad is used for the first time, 1st vehicle start function may not operate.

How to delete Digital Key (Smartphone)

Turn the vehicle on with the smart key and make sure to keep the smart key inside the vehicle during the digital key (smartphone) deleting process.

1. To Delete All Digital Keys

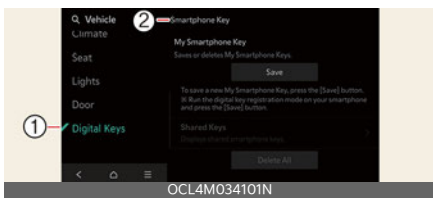

- 1) **Select Digital Keys**
- 2) **Select Smartphone key**

With the vehicle on, touch **Setup** → **Vehicle** → **Digital Keys** → **Smartphone key** → **Delete all** on the infotainment system.

- If there is no registered Key, the menu cannot be selected.

2. To Delete the owner's Digital Key



- 1) **Select Digital Keys**
- 2) **Select Smartphone key**
- 3) **My Smartphone Key**
- 4) **Select Delete**

A new smartphone can be registered after deleting the existing digital key (smartphone) from My Smartphone Key menu.

3. Deleting shared keys

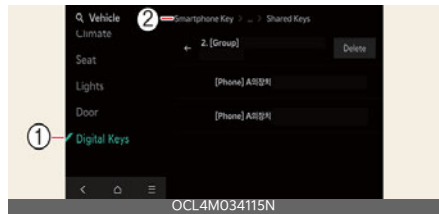

To delete a shared key (smartphone), select **Setup** > **Vehicle** > **Digital Keys** > **Smartphone Key** > **Shared keys** > **[Group]** > **Delete** from the infotainment system.

- Shared keys regards the digital key (smartphone) as [Group] except My smartphone key.
- If the account you log on to has not been changed, then it will be under the same [Group].
- You may delete Shared keys by the [Group]

*** NOTICE**

- If digital key (smartphone) is deleted, the digital key saved in the smartphone is also deleted.

- If digital key (smartphone) is deleted on the smartphone, the digital key saved in the vehicle is also deleted.
- Digital key (smartphone) is not deleted even if Kia Connect App is deleted on your smartphone.
- Digital key can be activated or deactivated within the Kia Connect App provided from the smartphone manufacturer.

*** INFORMATION**

The infotainment system may change after software updates. For more information, refer to the user's manual provided in the infotainment system and the quick reference guide.

Digital Key 2 (Card Key)

How to register Digital Key 2 (Card Key)

To use the card key as a digital key 2, register the card key in your vehicle system in accordance with the following procedures.

1. Enter your Kia with two smart keys.
2. Check if **Use** menu is activated.

With the vehicle on, touch **Setup** → **Vehicle** → **Digital Keys** → **NFC Card key** → **Use** on the infotainment system.

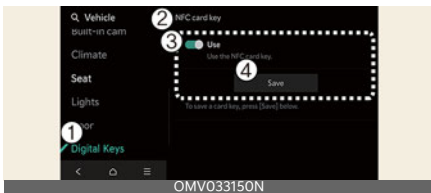

- 1) Digital Keys
- 2) NFC Card key

3) **Use**

4) **Save**

3. With the vehicle on, place the card key on the charging pad and press the **Save** menu on the infotainment system screen. The saving process will begin automatically.

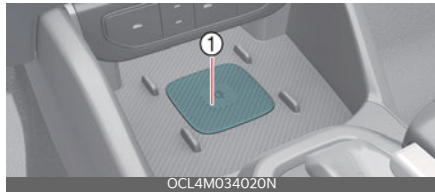

- 1) Charging pad

4. When the digital key (card key) is saved, a message will appear on the infotainment system screen.

*** INFORMATION**

- The infotainment system may change after software updates. For more information, refer to the user's manual provided in the infotainment system and the quick reference guide.
- When there is a digital key (card key) already saved in the vehicle, the **Save** menu is disabled. If you want to save a digital key again, refer to "How to delete Digital Key 2 (Card key)" on page 4-30 and follow the deleting procedure first before saving a digital key.
- To register the digital key (card key), the two smart keys must be in the vehicle.
- The registered digital key (card key) cannot be used for another vehicle.

How to use the Digital Key 2 (Card key)

Card key touch control

The driver can lock and unlock the door by touching the card key on the door handle. The vehicle can be started by placing the card key on the charging pad.



1 Door handle authentication pad

Locking/Unlocking the doors

- If the driver touches the NFC antenna of the registered card key on the driver's or passenger's door handle authentication pad (1) for more than 2 seconds, the door will lock or unlock.
- After locking the door, make sure to check its locked state. After unlocking the doors, the doors will automatically re-lock after 30 seconds unless a door is opened.
- It works only if the center of the NFC card key touches the NFC authentication area of the vehicle door handle.

* NOTICE

When touching a smartphone NFC antenna to the center of the outside door handle authentication pad, the doors will not lock with a beep sound in following conditions:

- When the Smart Key is in the vehicle
- When the ENGINE START/STOP button is in ACC or ON position

- When one or more doors, hood or trunk are open

Starting the vehicle

After placing your registered card key on the charging pad, depress the brake pedal and press the ENGINE START/STOP button to start the vehicle.

- Once the vehicle is started, you can remove the card key from the pad.

For more details, refer to "ENGINE START/STOP button (if equipped)" on page 5-7

⚠ WARNING

The vehicle can be started when the registered card key is placed on the charging pad. Therefore, do not leave unsupervised children or people who are not aware of the system since it can result in serious injury or death. In addition, always have the registered card key with you to prevent vehicle theft when leaving the vehicle.

⚠ CAUTION

- The digital key (card key) may not work under the following conditions:
 - When the card key is not touching the center of the door handle authentication pad or the charging pad correctly.
 - If the card key overlaps NFC-enabled cards such as credit card or smartphone.
 - If the card key does not work, move the card key approximately 10 cm (4 inches) away from the authentication pad and then touch it again.
- The card key can be damaged by impact. If the card key is damaged,

replace the card key with a new one and register it again.

- A damaged or lost card key is not covered by your warranty. The replacement cost is the owner’s responsibility.
- Long-time exposure to high temperature may cause the card key to malfunction. Be careful not to expose the key to direct sunlight or high temperature.
- If the card key is left on the charging pad while driving, it may cause malfunction of the card key. After starting the vehicle, make sure to separate the card key from the in-vehicle charging pad.
- If the card key is placed between the charging pad and the smartphone, and the smartphone is wirelessly charging, it may cause the card key to malfunction. For example, charging the smartphone while the card key is attached to the back of the smartphone case.

How to delete Digital Key 2 (Card key)

1. Turn the vehicle on with the smart key and make sure to keep the smart key inside the vehicle during the card key deleting process.
2. With the vehicle on, touch **Setup** → **Vehicle** → **Digital key** → **NFC card key** → **Delete** on the infotainment system.
The **Delete** menu will be disabled if there is no card key saved.

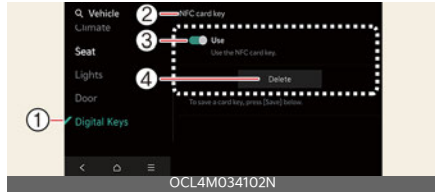

- 1) **Digital key**
 - 2) **NFC card Key**
 - 3) **Use**
 - 4) **Delete**
3. When the card key is deleted, a message will appear on the infotainment screen or cluster.

* INFORMATION

The infotainment system may change after software updates. For more information, refer to the user's manual provided in the infotainment system and the quick reference guide.

Personalized Profile and Vehicle Settings

You can link the user profile with the registered digital key (smartphone). If the account you log on to a smartphone has not been changed, then it will be under the same [Group]. All digital keys (smartphone) will be connected to the [Group].

Your vehicle will automatically activate with the registered profile if you get on the vehicle with your digital key (smartphone). You can refer to the following menus for keys under the same [Group], except my smartphone key.

Select **Setup** → **Vehicle** → **Digital Keys** → **Smartphone Key** → **Shared keys** → **[Group]** from the infotainment system. The infotainment system may change after software updates. For more information, refer to the user's manual pro-

vided in the infotainment system and the quick reference guide.

Linking/Unlinking profile

How to link user profile

1. Select **Setup** → **User profile** → **Profile Settings** → **Link Digital Key (Smartphone)** from Settings menu in the infotainment system.
2. Among the digital keys (smartphone) displayed on the screen, select the [Group] for the digital key (smartphone) you want to link to and follow the instructions.

How to unlink user profile

1. Select **Setup** → **User Profile** → **Profile Settings**, and then deselect "**Link Digital Key (Smartphone)**" from Settings menu in the infotainment system.
 - Unlinking is possible only when user profile is linked.

*** INFORMATION**

- The user profile cannot be linked to both Driver 1 and Driver 2 that are connected to a single smartphone. Personalization will operate with the recently linked user profile, and the previously linked user profile will be automatically canceled.
- User profile can be linked when Digital Key is registered on the smartphone and the vehicle. The smartphone with another vehicle's digital key cannot be linked.
- NFC card key cannot be linked with personalized profile.
- Once the user profile linked Digital Key in the smartphone is deleted, Dig-

ital Key 2 should be re-registered and personalized by linking the user profile again.

- The infotainment system may change after software updates. For more information, refer to the user's manual provided in the infotainment system and the quick reference guide.

Vehicle personalization operation

The personalization function linked with Digital Key 2 works under the following conditions:

- Touch the driver's door handle with the profile linked smartphone to lock or unlock the doors (Personalization does not operate when locking or unlocking the front passenger door.).
- The personalization function using the digital key can be operated after linking the digital key in the infotainment system profile menu.
- The personalization function works only when the vehicle is OFF or when the vehicle is started remotely. If the vehicle is not started remotely, personalization function does not work with the digital key.

*** INFORMATION**

User profile operation according to door lock/unlock system is as follows.

Item	Personalization operation
Initial value	Guest
Profile linked smartphone key	Linked profile
Profile unlinked smartphone key	Recently activated profile
NFC card key	
Smart key	

Vehicle personalization with Digital Key 2

The available personalization function in the vehicle is as follows.

System	Personalization Item	
Infotainment Settings menu	Lamp	Blink number of one-touch signal lamps
	Cluster	Information display on the cluster, Voice volume, Welcome sound
	Seat	Seat position
		Smart heating wire ventilation On/Off
	Door	Automatic door lock/unlock
	Smartphone wireless charging	Wireless charging On/Off
	Air conditioning	Setting up temperature unit, Block air inflow/Automatic ventilation Window defroster On/Off
	Navigation	Preferred volume of the navigation system
		Recent destination
	User preset	My menu list settings, Radio preset
Phone connectivity	Bluetooth preferential connection	
	CarPlay/Android Auto/MirrorLink On/Off	
Air conditioning	Operating condition	Latest operation setup of the following functions: Temperature (AUTO), air flow direction, air volume, air conditioner, air intake control, SYNC, Front windshield defroster, OFF

For more information of personalization, refer to the infotainment system manual.

CAUTION

If you leave the digital key in the vehicle after locking or unlocking the doors or starting the vehicle with the smart key, the doors can be locked with the central door lock. Always have the digital key with you.

Used Vehicle/Digital Key 2 Maintenance

Purchasing used vehicle

If you purchased a used car, please delete the smartphone key and card key (if equipped) registered by the previous user.

Be sure to notify an authorized Kia dealer when you purchase a used vehicle. Check whether the card key (if equipped) that came with the used vehicle operates properly. If the digital key (card key) (if equipped) does not work properly, delete the card key (if equipped) and register the smartphone key. Then re-register the card key (if equipped).

Digital Key 2 Maintenance

If you need to have your Digital Key 2 System repaired or replaced, the registered digital key (smartphone/card key) (if equipped) can be deleted depending on the type of maintenance.

Limitations of the System

- Digital Key 2 may not work if any of the following occurs:
 - Smartphone battery or the vehicle battery is discharged
 - NFC or Bluetooth is turned off in the smartphone settings
 - A credit card overlaps the back of your smartphone, or metal or thick smartphone case is used
 - Using the card key (if equipped) with other cards, or using it in a wallet or cardholder
 - There is electronic interference by other vehicles, objects, etc.
- There may be a communication error with Digital Key 2 NFC function if a metallic cover or communication device is attached to the smartphone. If there is a malfunction of Digital Key 2, remove the cover attached to the smartphone and try again.
- The vehicle may not be controlled by the smartphone if any of the following occurs:
 - Basic and necessary functions of the smartphone are operating (general call, urgent call, audio or contactless payment)
 - Using wireless earphone (general call, urgent call or audio)
 - When Digital Key 2 app function is being limited due to smartphone default settings or app launch priority policy per manufacturer

Integrated Memory System (if equipped)

Integrated Memory System for the driver's seat is provided to store and recall the following memory settings with a simple button operation.



- Driver's seat position
- Outside rearview mirror position

⚠ WARNING

Never attempt to operate the integrated memory system while the vehicle is moving.

This could result in loss of control, and an accident causing death, serious injury, or property damage.

*** INFORMATION**

- If the battery is disconnected, the memory settings will be erased.
- If the driver position memory system does not operate normally, have the vehicle checked by an authorized Kia dealer.

Storing memory positions

1. Shift to P (Park) while the ignition switch or ENGINE START/STOP button is in the ON position.
2. Adjust the driver's seat position and outside rearview mirror position to the desired position.
3. Hold the button (1 or 2). The system will beep once and notify you **Driver 1 (or 2) settings saved** will appear on the infotainment screen.

Recalling memory positions

1. Shift to P (Park) while the ignition switch or ENGINE START/STOP button is in the ON position.
2. Press the desired memory button (1 or 2). The system will beep once, and then the driver's seat position and outside rearview mirror position will automatically adjust to the stored positions.
3. **Driver 1 (or 2) settings applied** will appear on the infotainment screen.

Seat easy access

Seat easy access will move the driver's seat and steering wheel automatically as follows:

Exiting the vehicle:

- The driver's seat will move as follows when the ignition switch or ENGINE START/STOP button is in the OFF position with the gear in P (Park) and the driver's door open.
- Driver seat: Moves rearward depending on the distance selected from the Settings menu in the infotainment system. However, the driver's seat may not move rearward if there is not enough space between the driver's seat and the rear seats.

Entering the vehicle:

- The driver's seat will move as follows when the ignition switch or ENGINE START/STOP button is pressed to the ACC, ON or START position or while carrying the smart key, the driver's door is closed with the Start/ Stop button in the OFF position.
 - Driver seat, Steering wheel position: Moves back to its original position.
- You can set the Seat Easy Access function from the Settings menu in the infotainment system screen.
 - Driver seat: **Setup** → **Vehicle Settings** → **Seat** → **Seating Easy Access** → **Driver Seat Easy Access** → **Normal/Extended/Off**.

Resetting the System

Take the following procedures to reset integrated memory system, when it does not operate properly.

Resetting integrated memory system

1. Stop the vehicle and open the driver's door with the ignition switch or ENGINE START/STOP button in the ON position and the vehicle shifted to P (Park).
2. Adjust the driver's seat and seatback to the foremost position.
3. Press the memory button 1 (or 2) and push forward the driver's seat movement switch over 2 seconds simultaneously.

While resetting integrated memory system

1. Resetting starts with a notification sound.
2. The driver's seat and seatback is adjusted to the rearward position with the notification sound.
3. The driver's seat and seatback is re-adjusted to the default position (central position) with the notification sound. However, in the following cases, the resetting procedure and the notification sound may stop.
 - The memory button is pressed.
 - The seat control switch is operated.
 - The gear is shifted out of P (Park).
 - The driving speed exceeds 5 km/h (3 mph).
 - The driver's door is closed.

*** NOTICE**

- While integrated memory system is being reset, if the resetting and notification sound stops incompletely, restart the resetting procedure again.
- Make sure that there is no objects around the driver's seat in advance of resetting the integrated memory system.
- After resetting the integrated memory system, the adjustment for the driver seat must be stored again to recall the memory position.

Trunk

Opening the trunk

1. Make sure the vehicle is in P (Park) and set the parking brake.
2. To open the trunk:
 - Use the trunk release lever or trunk open switch equipped on trunk lid.



- Hold down the trunk open button located on your smart key for more than 1 second.

Additionally, for vehicles equipped with smart key:

- While all doors are unlocked, press the unlock button to open trunk with or without the smart key in your possession.
- If any door is locked or all doors are locked, the switch can still be used to open the trunk, as long as the smart key is in your possession.

*** NOTICE**

The trunk switch is made of plastic. Do not press it using a sharp object such as a key, screwdriver, or drill.

3. Lift the trunk lid up.

* NOTICE

In cold and wet climates, door lock and door mechanisms may not work properly due to freezing conditions.

⚠ WARNING

The trunk swings upward. Make sure no objects or people are near the rear of the vehicle when opening the trunk.

⚠ CAUTION

Make certain that you close the trunk before driving your vehicle. Possible damage may occur to the trunk torsion bars and attached hardware if the trunk is not closed prior to driving.

Closing the trunk

Lower the trunk lid and press down until it locks. To be sure the trunk lid is securely fastened, always check by trying to pull it up again.

⚠ WARNING

Exhaust Fumes

The trunk should always be kept completely closed while the vehicle is in motion. If it is left open or ajar, poisonous exhaust gases may enter the car and serious illness or death may result.

⚠ WARNING

Make sure your hands, feet and other parts of your body are safely out of the way before closing the trunk.

Emergency trunk safety release

Inside the trunk

Your vehicle is equipped with an Emergency Trunk Safety Release lever located inside the trunk. If someone is inadvertently locked in the trunk, the trunk can be opened by moving the lever in the direction of the arrow and pushing the trunk open.



⚠ WARNING

- You and your passengers must be aware of the location of the Emergency Trunk Safety Release lever in this vehicle and how to open the trunk in case you are accidentally locked in the trunk.
- NEVER allow anyone to occupy the trunk of the vehicle at any time. If the trunk is partially or totally latched and the person is unable to get out, serious injury or death could occur due to lack of ventilation, exhaust fumes and rapid heat build-up, or because of exposure to cold weather conditions. The trunk is also a highly dangerous location in the event of a crash because it is not a protected occupant space but is a part of the vehicle's crush zone.
- Your vehicle should be kept locked and the Smart Key should be kept out of the reach of children. Parents should teach their children about the dangers of playing in trunks.

- Use the release lever for emergencies only.

⚠ WARNING

- No one should be allowed to occupy the cargo area of the vehicle at any time. The cargo area is a very dangerous location in the event of a crash.
- Use the release lever for emergencies only. Use with extreme caution, especially while the vehicle is in motion.

*** NOTICE**

Make sure there are no people or objects around the trunk before opening or closing the trunk. Wait until the trunk is open fully and stopped before loading or unloading cargo from the vehicle.

Smart Trunk (if equipped)

On a vehicle equipped with a smart key, the trunk can be opened using the Smart Trunk system.



How to use the Smart Trunk

The trunk can be opened with no-touch activation satisfying all the conditions below.

- After 15 seconds when all doors are closed and locked
- Positioned in the detecting area for more than 3 seconds.

*** NOTICE**

The Smart Trunk does not operate when:

- The smart key is detected within 15 seconds after the doors are closed, locked, and is continuously detected.
- The smart key is detected within 15 seconds after the doors are closed and locked, and 1.5 m (60 inches) from the front door handles. (for vehicles equipped with Welcome Light)
- A door is not locked or closed.
- The smart key is in the vehicle.

1. Setting

To activate the Smart Trunk, go to Settings menu and select Smart Trunk on the infotainment system screen.

2. Detect and Alert



If you are positioned in the detecting area (50-100 cm (20-39 inches)) behind the vehicle carrying a smart key, the hazard warning lights will blink and chime will sound to alert you the smart key has been detected and the trunk will open.

* NOTICE

Do not approach the detecting area if you do not want the trunk to open. If you have unintentionally entered the detecting area and the hazard warning lights and chime starts to operate, leave the detecting area with the smart key. The trunk will stay closed.

3. Automatic opening



The hazard warning lights will blink and chime will sound 6 times and then the trunk will open.

⚠ WARNING

- Make sure you close the trunk before driving your vehicle.

- Make sure there are no people or objects around the trunk before opening or closing the trunk.
- Make sure to deactivate the Smart Trunk when washing your vehicle. Otherwise, the trunk may open inadvertently.

⚠ CAUTION

Trunk lift

Make certain that you close the trunk before driving your vehicle. Possible damage may occur to the trunk torsion bars and attached hardware if the trunk is not closed prior to driving.

⚠ WARNING

Make sure objects in the rear cargo area do not come out when opening the trunk as this could cause serious injury.

* NOTICE

The key should be kept out of reach of children. Children may inadvertently open the Smart Trunk while playing around the rear area of the vehicle.

How to deactivate the Smart Trunk function using the smart key



- 1 Door lock
- 2 Door unlock
- 3 Trunk open
- 4 Panic button

If you press any button of the smart key during the Detect and Alert stage, the Smart Trunk function will be deactivated.

Make sure to be aware of how to deactivate the Smart Trunk function for emergency situations.

* NOTICE

- If you press the door unlock button (2), the Smart Trunk function will be deactivated temporarily. But, if you do not open any door for 30 seconds, the Smart Trunk function will be activated again.
- If you press the trunk open button (3) for more than 1 second, the trunk opens.
- If you press the door lock button (1) or trunk open button (3) when the Smart Trunk function is not in the Detect and Alert stage, the Smart Trunk function will not be deactivated.
- In case you have deactivated the Smart Trunk function by pressing the smart key button and opening a door, the Smart Trunk function can be acti-

uated again by closing and locking all doors.

Detecting area



- 1 50-100 cm (20-39 inches)
- The Smart Trunk operates with a welcome alert if the smart key is detected within 50-100 cm (20-39 inches) from the trunk.

The alert stops at once if the smart key is positioned outside the detecting area during the Detect and Alert stage.

* NOTICE

- The Smart Trunk function will not work if any of the following occurs:
 - The smart key is close to a radio transmitter such as a radio station or an airport which can interfere with normal operation of the transmitter.
 - The smart key is near a mobile two-way radio system or a cellular phone.
 - Another vehicle's smart key is being operated close to your vehicle.
- The detecting range may decrease or increase when:

- One side of the tire is raised to replace a tire or to inspect the vehicle.

The vehicle is slantingly parked on a slope or unpaved road, etc.

Windows

The doors of this vehicle are equipped with power windows that can be operated by a switch.

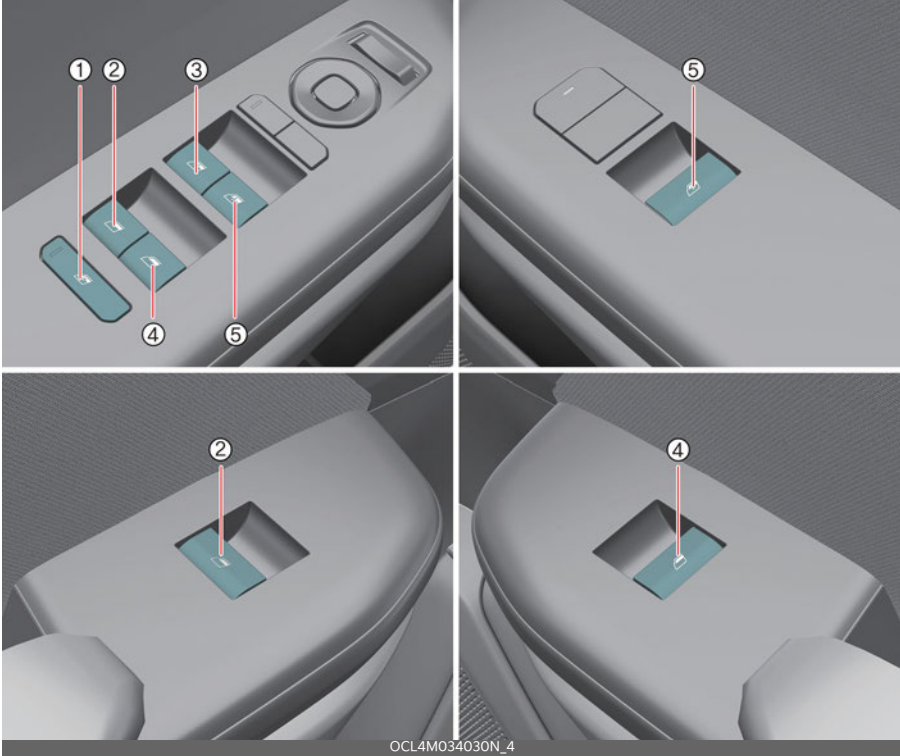

- 1 Power window lock switch
- 2 Rear door (left) power window switch
- 3 Driver's door power window switch
- 4 Rear door (right) power window switch
- 5 Front passenger's door power window switch

* NOTICE

In cold and wet climates, power windows may not work properly due to freezing conditions.

The ignition switch or ENGINE START/ STOP button must be in the ON position for power windows to operate.

Each door has a power window switch that controls the door's window. The driver has a power window lock button which can block the operation of rear passenger windows. The power windows can be operated for approximately 3 minutes after the ignition switch or ENGINE START/STOP button turned to the ACC position. If the front doors are opened, the power windows cannot be operated even within the 3 minutes period.

The driver's door has a master power window switch that controls all the windows in the vehicle.

If the window cannot be closed because it is blocked by objects, remove the objects and close the window.

*** NOTICE**

While driving with the rear windows down or with the sunroof (if equipped) in an open (or partially open) position, your vehicle may demonstrate a wind buffeting or pulsation noise. This noise is a normal occurrence and can be reduced or eliminated by taking the following actions. If the noise occurs with one or both of the rear windows down, partially lower both front windows approximately 2.5 cm (1 inch) If you experience the noise with the sunroof open, slightly reduce the size of the sunroof opening.

▲ CAUTION

Do not install any accessory in the vehicle that extend into the open window area. Such an object will impact the proper function of the Automatic reversal "jam protection" feature.

*** NOTICE**

If you press the one-touch window button for micro adjustment, the glass will move to a specific location to improve your convenience.

Window opening and closing

You can open and close windows using the power window switch.

Type A



To open or close a window, press down or pull up the front portion of the corresponding switch to the first detent position (1).

Type B - Auto up/down window



Pressing or pulling up the power window switch momentarily to the second detent position (2) completely lowers or raises the window even when the switch is released. To stop the window at the desired position while the window is in operation, pull up or press down and release the switch.

To reset the power windows

If the power window does not operate normally, the automatic power window system must be reset as follows:

1. Turn the ignition switch or ENGINE START/STOP button to the ON position.
2. Close the window and continue pulling up the power window switch for at least 1 second after the window is completely closed.

Automatic reversal (if equipped)

If the upward movement of the window is blocked by an object or part of the body, the window will detect the resistance and will stop upward movement. The window will then lower approximately 30 cm (11.8 inches) to allow the object to be cleared.

If the window detects the resistance while the power window switch is pulled up continuously, the window will stop upward movement and then lower approximately 2.5 cm (1 inch).

If the power window switch is pulled up continuously again within 5 seconds after the window is lowered by the automatic window reversal feature, the automatic window reversal will not operate.

* NOTICE

The automatic reverse feature for the window is only active when the "auto up" feature is used by fully pulling up the switch. The automatic reverse feature will not operate if the window is raised using the halfway position on the power window switch.

⚠ WARNING

Always check for obstructions before raising any window to avoid injuries or vehicle damage. If an object less than 4 mm (0.16 of an inch) in diameter is caught between the window glass and the upper window channel, the automatic reverse window may not detect the resistance and will not stop and reverse direction.

⚠ WARNING

The automatic reverse feature doesn't activate while resetting the power window system. Make sure body parts or other objects are safely out of the way before closing the windows to avoid injuries.

⚠ CAUTION

Do not install any accessories in the vehicle that extend into the open window area. Such objects could prevent the automatic reverse feature from functioning.

Power window lock button

The driver can disable the power window switches on the rear passengers' doors by pressing the power window lock button to the lock position (pressed).



When the power window lock button is pressed:

- The driver's master control can operate all passengers' power windows.
 - The front passenger's control can operate the front passenger's power window.
 - The rear passengers' control cannot operate the rear passenger's power window.
- * If the power window lock switch is operated (indicator turns on), rear passenger cannot open the rear door. (if equipped with the Electronic Child Safety Lock System.) For more details, refer to "Special driving conditions" on page 5-40.

CAUTION

- To prevent possible damage to the power window system, do not open or close two windows or more at the same time. This will also ensure the longevity of the fuse.
- Never try to operate the main switch on the driver's door and the individual door window switch in opposite directions at the same time. If this is done, the window will stop and cannot be opened or closed.

WARNING

Windows

- NEVER leave the keys in your vehicle with unsupervised children, when the engine is running.
- NEVER leave any child unattended in the vehicle. Even very young children may inadvertently cause the vehicle to move, entangle themselves in the windows, or otherwise injure themselves or others.
- Always double check to make sure all arms, hands, head and other obstructions are safely out of the way before closing a window.
- Do not allow children to play with the power windows. Keep the driver's door power window lock button in the LOCK position (pressed). SERIOUS INJURY can result from unintentional window operation by the child.
- Do not extend heads or any limbs outside the window while the vehicle is in motion.

Remote window opening (if equipped)



If Auto up/down window function (safety window function) is equipped, you can still control the corresponding windows movement with engine turned off.

Press the Door Unlock button for more than 3 seconds. The window moves down after the doors are unlocked, as long as you press the door unlock but-

ton. The window movement stops, when you release the door unlock button.

* Remote window opening requires the auto up/down window to be applied.

* NOTICE

If you stay on the function after operating the Remote window opening function, it is likely to cause a theft. In addition, please use caution there might be a malfunction due to the inflow of water while raining.

* NOTICE

- The remote window opening function may abruptly stop, when you move away from your vehicle during operation. Stay in proximity from your vehicle, while monitoring the window movement.
- One of the windows may stop operating, when the window is interrupted by certain force. However, the other windows will keep operating. Thus, you should make sure that all windows are opened.
- Be careful when using the remote window opening function, as the doors will be unlocked.

Hood

The hood serves as a cover for the engine compartment.

Open the hood if maintenance work needs to be performed in the engine compartment or if you need to look at the compartment.

Opening the hood

1. Pull the release lever to unlatch the hood. The hood should pop open slightly.



2. Go to the front of the vehicle, raise the hood slightly, push the Secondary hood release lever (1) to the left and lift the hood (2).



3. Pull out the support rod.



4. Hold the hood opened with the support rod.

⚠ WARNING**Support rod**

- After driving, the engine compartment and support rod will be hot. Grasp the support rod in the area wrapped in rubber to prevent burns.



- The support rod must be inserted completely into the hole provided whenever you inspect the engine compartment. This will prevent the hood from falling and possibly injuring you.

Hood open warning

The hood warning message will appear on the LCD display when hood is open.

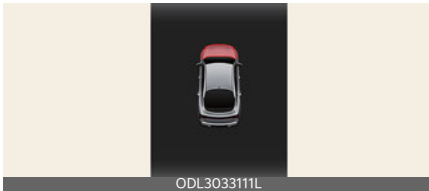

The warning chime will operate when the vehicle is being driven at or above 3 km/h (2 mph) with the hood open.

Closing the hood

1. Before closing the hood, check the following:
 - All filler caps in the engine compartment must be correctly installed.
 - Gloves, rags or any other combustible material must be removed from the engine compartment.
2. Lower the hood until it is about 30 cm (12 in) above the closed position and let it drop. Make sure that it locks into place.
3. Check that the hood has engaged properly.
 - If the hood can be raise slightly, it is not properly engaged.
 - Open it again and close it with a little more force.

⚠ CAUTION**Hood obstruction**

Before closing the hood, ensure that all obstructions are removed from the hood opening. Closing the hood with an obstruction present in the hood opening may result in severe personal injury or properly damage.

⚠ WARNING**Fire risk**

Do not leave gloves, rags or any other combustible material in the motor compartment. Doing so may cause a heat-induced fire.

⚠ WARNING**Unsecured hood**

Always double check to be sure that the hood is firmly latched before driving away. If it is not latched, the hood could fly open while the vehicle is being driven, causing a total loss of visibility, which may result in an accident.

Fuel filler door

The vehicle's fuel filler door must be opened and closed by hand from outside the vehicle.

Opening the fuel filler door

1. Turn the engine off.
2. To open the fuel filler door, pull up the fuel filler door opener.

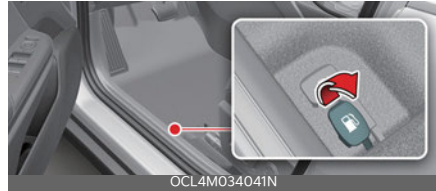

3. Pull the fuel filler door (1) out to fully open.

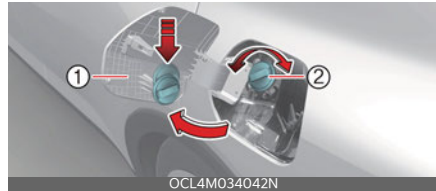

4. To remove the fuel tank cap (2), turn it counterclockwise. You may hear a hissing noise as the pressure inside the tank equalizes.
5. Place the cap on the fuel filler door.

*** NOTICE****The fuel filler door will unlock when Driver's door is unlocked**

To unlock the fuel filler door, follow one of the following instructions:

- Press the unlock button on your smart key
- Press the central door unlock button on armrest trim of driver's door
- Pull the driver's inside door handle outward

⚠ CAUTION

Before refueling, be sure to check what type of fuel is used for your vehicle. If you put diesel fuel into a gasoline-powered vehicle, it may affect the fuel system and cause serious damage to the vehicle.

*** NOTICE**

- If the fuel filler door does not open because ice has formed around it, tap lightly or push on the door to break the ice and release the door. Do not pry on the door. If necessary, spray around the door with an approved deicer fluid (do not use radiator anti-freeze) or move the vehicle to a warm place and allow the ice to melt.
- If the fuel filler door does not open under certain conditions, such as an electrical malfunction, contact an authorized Kia dealer.

Closing the fuel filler door

1. To install the fuel tank cap, turn it clockwise until it "Clicks".
2. Close the fuel filler door and push it lightly and make sure that it is securely closed.

*** NOTICE**

Press the vehicle's fuel door to LOCK position when the fuel filler door is completely closed to lock the fuel filler door. If the fuel filler door is not completely closed, the fuel filler door will not be locked.

After closing the fuel filler door, you must lock all vehicle doors to lock it completely. To lock the fuel filler door, do one of the following:

To lock fuel filler door:

- Press the lock button on your smart key
 - Press the central door lock button on armrest trim of driver's door
- * All doors will automatically lock after the vehicle speed exceeds 15 km/h (9 mph) Fuel door is also locked when vehicle speed exceeds 15 km/h (9 mph)

⚠ WARNING**Refueling**

Always remove the fuel cap carefully and slowly. If the cap is venting fuel or if you hear a hissing sound, wait until the condition stops before completely removing the cap.

If pressurized fuel sprays out, it can cover your clothes or skin and subject you to the risk of fire and burns.

*** NOTICE**

When refueling on uneven ground, the fuel gauge may not point to the F position. It is not a malfunction. If you move your vehicle to a level ground, the fuel gauge will move to the full position.

*** NOTICE**

Tighten the cap until it clicks one time, otherwise, the engine warning indicator light will appear.

⚠ CAUTION

Keep the door into LOCK position when the vehicle is being washed (i.e. high

pressure washer, automatic car washer, etc.)

⚠ WARNING

Always tighten your fuel cap before you leave the fuel station. Failure to securely install your fuel cap can lead to fuel spillage in an accident and increase fire risk.

⚠ WARNING

Fire/explosion risk

Read and follow all warnings posted at the gas station facility. Failure to follow all warnings will result in severe personal injury, severe burns or death due to fire or explosion.

⚠ WARNING

Static electricity

- Before touching the fuel nozzle, you should eliminate potentially dangerous static electricity discharge by touching another metal part of the vehicle, a safe distance away from the fuel filler neck, nozzle, or other gas source.
- Do not enter your vehicle once you have begun refueling since you can generate static electricity by touching, rubbing or sliding against any item or fabric (polyester, satin, nylon, etc.) capable of producing static electricity. Static electricity discharge can ignite fuel vapors resulting in rapid burning. If you must reenter the vehicle, you should once again eliminate potentially dangerous static electricity discharge by touching a metal part of the vehicle, away from the fuel filler neck, nozzle or other gasoline source.

⚠ WARNING

Portable fuel container

When using an approved portable fuel container, be sure to place the container on the ground prior to refueling. Static electricity discharge from the container can ignite fuel vapors causing a fire. Once refueling has begun, contact with the vehicle should be maintained until the filling is complete. Use only approved portable plastic fuel containers designed to carry and store gasoline.

⚠ WARNING

Cell phone fires

Do not use cellular phones while refueling. Electric current and/or electronic interference from cellular phones can potentially ignite fuel vapors causing a fire.

⚠ WARNING

Refueling and vehicle fires

When refueling, always shut the engine off. Sparks produced by electrical components in the engine can ignite fuel vapors causing a fire. Once refueling is complete, check to make sure the filler cap and filler door are securely closed, before starting the engine.

⚠ WARNING

Smoking

DO NOT use matches or a lighter and DO NOT SMOKE or leave a lit cigarette in your vehicle while at a gas station especially during refueling. Automotive fuel is highly flammable and can result in fire when ignited.

Make sure to refuel your vehicle according to "Fuel requirements" on page 1-2. If the fuel filler cap requires replacement, use only a genuine Kia cap or the equivalent specified for your vehicle. An incorrect fuel filler cap can result in a serious malfunction of the fuel system or emission control system.

⚠ CAUTION

Exterior paint

Do not spill fuel on the exterior surfaces of the vehicle. Any type of fuel spilled on painted surfaces may damage the paint.

⚠ WARNING

- Do not allow anyone that has not discharged static electricity from their body to come close to an open fuel tank.
- Do not inhale vaporized fuel.

⚠ WARNING

Risk of injury from fuel

Fuels are poisonous and harmful to your health.

- Fuel contains substances that are harmful if inhaled.
- Do not swallow fuel or let it contact skin, eyes or clothing.
- Do not inhale fuel vapors.
- Keep children away from fuel.

If you or other people contact fuel, observe the following:

- Immediately rinse fuel off your skin with soap and water.
- If fuel contacts your eyes, immediately rinse them thoroughly with clean water. Seek medical attention immediately.

- If you swallow fuel, seek medical attention immediately. Do not induce vomiting.
- Change immediately out of clothing that has contacted fuel.

*** NOTICE**

Damage caused by the wrong fuel

- Fuel that does not conform to the required quality can lead to increased wear as well as damage to the engine and exhaust system. Only use the fuel recommended.
- Vehicles with a gasoline engine: Even small amounts of the wrong fuel could result in damage to the fuel system, the engine and the emission control system.
- Do not use diesel to refuel vehicles with a gasoline engine.

*** NOTICE**

Do not switch on the ignition if you accidentally refuel with the wrong fuel. Fuel can enter the fuel system.

Even small amounts of the wrong fuel could result in damage to the fuel system and the engine. Have the system serviced by an authorized Kia dealer.

*** NOTICE**

Do not overfill the fuel tank

Do not overfill the fuel tank. Fuel may spill, causing harm to the environment and damaging the vehicle.

Wide sunroof (if equipped)

If your vehicle is equipped with a sunroof, you can slide or tilt your sunroof with the sunroof switch located on the overhead console.



The sunroof can only be operated when the ignition switch or ENGINE START/STOP button is in the ON or START position. The sunroof can be operated for approximately 3 minutes after the ignition switch or ENGINE START/STOP button is in the ACC or LOCK/OFF position. However, if the front door is open, the sunroof cannot be operated even within the 3 minutes period.

⚠ WARNING

- Be sure to operate the sunroof while the car is stationary. If you operate the sunroof while driving, it may interfere with driving and cause an accident.
- Even when leaving the vehicle for a short time, turn off the ignition and carry the key to prevent children from operating the sunroof.
- Do not sit on the roof. Sitting on a roof or lifting heavy objects can damage the sunroof.

*** NOTICE**

Do not operate the sunroof when roof bars are installed on the vehicle or when there is luggage on the roof.

Power sunshade



Use the power sunshade to block direct sunlight coming through the sunroof glass.

- Push the sunroof switch rearward to the first detent position, the power sunshade automatically slides open.
- Push the sunroof switch forward to the first detent position, the power sunshade automatically closes. However, if the sunroof glass is open, the glass will close first.

To stop the power sunshade at any point, push the sunroof switch in any direction.

*** NOTICE**

Do not pull or push the power sunshade by hand as such action may damage the power sunshade or cause it to malfunction.

*** INFORMATION**

Wrinkles formed on the power sunshade are normal due to material characteristic.

Tilt open/close



- Push the sunroof switch upward, the sunroof glass tilts open. However, if the power sunshade is close, the sunshade will open first.
- Push the sunroof switch upward or forward when the sunroof glass is tilt opened, the sunroof glass automatically closes.

To stop the sunroof movement at any point, push the sunroof switch in any direction.

Slide open/close



- Push the sunroof switch rearward to the first detent position, the sunroof glass opens. However, if the power sunshade is close, the power sunshade will open first.
Push the sunroof switch forward to the first detent position, the sunroof glass closes. However, if the sunroof glass is close, the power sunshade will close.
- Push the sunroof switch forward or rearward to the second detent position, the power sunshade and sunroof glass operate automatically (auto slide feature).

To stop the sunroof movement at any point, push the sunroof switch in any direction.

Automatic reversal



If the power sunshade or sunroof glass senses any obstacle while it is closing automatically, it will reverse direction then stop at a certain position.

The auto reverse function may not work if an object thin or soft is caught between the sliding power sunshade or sunroof glass and sunroof sash.

⚠ WARNING

- Make sure heads, hands, arms or any other body parts or objects are out of the way before operating the sunroof. Body parts or objects may get caught causing injuries or vehicle damage.
- Never deliberately use your body parts to test the automatic reversal function. The power sunshade or sunroof glass may reverse direction, but there is a risk of injury.

* NOTICE

- Do not continue to push the sunroof switch after the sunroof is fully opened, closed, or tilted. Damage to the sunroof motor could occur.
- Continuous operations such as slide open/close, tilt open/close, etc. may cause the motor or sunroof system to malfunction.

- Regularly remove any accumulated dust on the sunroof rail.
- Dust accumulated between the sunroof and roof panel can make noise. Open the sunroof and remove dust regularly using a clean cloth.
- Do not try to open the sunroof when the temperature is below freezing or when the sunroof is covered with snow or ice. The sunroof may not work properly and may break if opened by force.
- Do not open or drive with the sunroof glass open immediately after rain or washing the vehicle. Water may wet the interior of the vehicle.
- Do not extend any luggage outside the sunroof while driving. Vehicle damage may occur if the vehicle suddenly stops.

⚠ WARNING

Do not extend your head, arms, body parts or objects outside the sunroof while driving. Injuries may occur if the vehicle suddenly stops.

Resetting the sunroof



In some circumstances resetting the sunroof operation may need to be performed. Some instances where resetting the sunroof may be required include:

- When the 12-volt battery is either disconnected or discharged
- When the sunroof fuse is replaced

- If the sunroof one-touch AUTO OPEN/CLOSE operation is not functioning properly

Sunroof resetting procedure:

1. It is recommended to perform the reset procedure with the vehicle engine running. Start the vehicle in P (Park).
2. Make sure the power sunshade and sunroof glass are in the fully closed position. If the power sunshade and sunroof glass are open, push the switch forward until the power sunshade and sunroof glass are fully closed.
3. Release the switch when the power sunshade and sunroof glass are fully closed.
4. Push the switch forward until the power sunshade and sunroof glass move slightly. Then release the switch.
5. Once again push and hold the sunroof switch forward until the power sunshade and sunroof glass slide open and close. Do not release the switch until the operation is completed. If you release the switch during operation, start the procedure again from step 2.

*** NOTICE**

If the sunroof does not reset when the vehicle battery is disconnected or discharged, or the sunroof fuse is blown, the sunroof may not operate normally.

Sunroof open warning

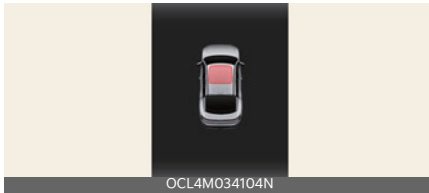

If the driver turns off the engine when the sunroof is not fully closed, the warning chime will sound for several seconds and the sunroof open warning will appear on the cluster LCD display. Close the sunroof securely when leaving your vehicle.

⚠ CAUTION

Make sure the sunroof is closed fully when leaving your vehicle. If the sunroof is left open, rain or snow may wet the interior of the vehicle. Also, leaving the sunroof open when the vehicle is unattended may invite theft.

Steering wheel

The steering wheel of this vehicle is equipped with the Motor Driven Power Steering (MDPS) system.

Motor Driven Power Steering (MDPS)

Power steering uses the motor to assist you in steering the vehicle.

If the engine is off or if the power steering system becomes inoperative, the vehicle may still be steered, but it will require increased steering effort.

The MDPS is controlled by the power steering control unit which senses the steering wheel torque and vehicle speed to command the motor.

The steering effort becomes heavier as the vehicle's speed increases and becomes lighter as the vehicle's speed decreases for better control of the steering wheel.

Should you notice any change in the effort required to steer during normal vehicle operation, have the power steering checked by an authorized Kia dealer.

*** NOTICE**

The following symptoms may occur during normal vehicle operation:

- When the ignition switch or ENGINE START/STOP button is the ON position, the steering wheel enters normal operation mode after diagnosing the Motor Driven Power Steering system (for about 3 seconds).
- A click noise may be heard from the MDPS relay after turning the ignition switch or ENGINE START/STOP button is turned to the ON or OFF position.
- If the steering wheel is operated when the vehicle is not in motion or driven

at a low speed, you may hear some noise.

- If the Motor Driven Power Steering system does not operate normally, the warning light will appear or blink on the instrument cluster. If the power assistance of steering fails, you will need to use more force to steer.
- Operating the steering wheel at lower temperatures may require more force and accompany noise. However, when the temperature increases, it returns to normal.
- Take your vehicle to an authorized Kia dealer and have the vehicle checked as soon as possible.
- When the charging system warning light comes on due to the low voltage (when the alternator or battery does not operate normally or malfunctions), the steering wheel may require increased steering effort.

* NOTICE

When you continuously operate the steering wheel, the overcurrent protection device is activated and it requires more force to operate the steering wheel. However, this doesn't indicate a malfunction, and it works for your safety and will return to normal after some time.

* NOTICE

If the Motor Driven Power Steering (MDPS) system does not work or an error occurs, the warning light on the instrument panel may be turned on or blink and it may require more force to operate the steering wheel. In this case, please hold the steering wheel more tightly than usual and operate with

greater force. And then immediately pull your vehicle over to a safe place and have your vehicle inspected by an authorized Kia dealer.

Tilt & telescopic steering wheel

A tilt and telescopic steering wheel allows you to adjust the steering wheel before you drive. You can also raise it to give your legs more room when you exit and enter the vehicle.

The steering wheel should be positioned so that it is comfortable for you to drive, while permitting you to see the instrument panel warning lights and gauges.

⚠ WARNING

Steering wheel adjustment

Never adjust the angle and height of the steering wheel while driving. You may lose steering control.

Adjusting steering wheel angle and height

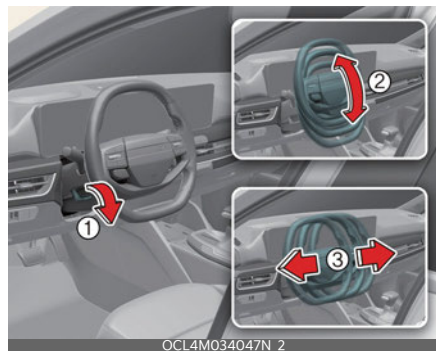

1. To change the steering wheel angle, pull down the lock release lever (1).
2. Adjust the steering wheel to the desired height (2) and forward/backward position (3).

Move the steering wheel, so it points toward your chest, not toward your face. Make sure you can see the instrument panel warning lights and gauges. After adjusting, pull up the lock.

3. Pull up the lock-release lever to lock the steering wheel in place.
Push the steering wheel both up and down to be certain it is locked in position.
4. Be sure to adjust the steering wheel to the desired position before driving.

*** NOTICE**

After adjustment, sometimes the lock-release lever may not lock the steering wheel.

It is not a malfunction. This occurs when two gears engage. In this case, adjust the steering wheel again to lock the steering wheel.

Heated steering wheel (if equipped)

When the ignition switch or ENGINE START/STOP button is in the ON position, pressing the heated steering wheel button warms the steering wheel. The indicator on the button will illuminate.



- Press the steering wheel heater button. When you press the steering wheel heater button, the indicator lights up and the steering wheel will warm.

- To prevent low-temperature burns, the steering wheel temperature is automatically adjusted after the steering wheel heater is manually turned on.

Steering wheel heater level	Operating time
Off	-
2 (Strong)	30 minutes
1 (Weak)	Until restart

- When using the steering wheel heater in the 2nd level (strong), it automatically lowers to the 1st level (weak) after about 30 minutes.
- If the user does not manually operate the steering wheel heater, it is maintained at the 1st level (weak) until the vehicle is turned off.
- To turn off the steering wheel heater, press and hold the steering wheel heating button until the indicator light goes out.

⚠ CAUTION

- Do not install any type of grip cover for the steering wheel, it may impair the function of the heated steering wheel system.
- When cleaning the heated steering wheel, do not use an organic solvent such as paint thinner, benzene, alcohol or gasoline. Doing so may damage the surface of the steering wheel.
- If the surface of the steering wheel is struck by a sharp object, damage to the heated steering wheel components could occur.

⚠ WARNING

If the steering wheel becomes too warm, turn the system off. The heated steering wheel may cause burns even at low tem-

peratures, especially if used for a long time.

Horn

To sound the horn, press the area indicated by the horn symbol on your steering wheel (see illustration).



The horn will operate only when this area is pressed. Check the horn regularly to be sure it operates properly.

* NOTICE

To sound the horn, press the area indicated by the horn symbol on your steering wheel (see illustration). The horn will operate only when this area is pressed.

⚠ CAUTION

Do not strike the horn severely to operate it, or hit it with your fist. Do not press on the horn with a sharp-pointed object.

Mirrors

This vehicle is equipped with inside and outside rearview mirrors to provide views of objects behind the vehicle.

Inside rearview mirror

Adjust the rearview mirror so that the center view through the rear window is seen. Make this adjustment before you start driving.

Do not place objects in the rear seat or cargo area which would interfere with your vision out the rear window.

⚠ WARNING

Mirror adjustment

Do not adjust the rearview mirror while the vehicle is moving. This could result in loss of control.

* NOTICE

Do not modify the inside mirror in any manner, including installing a wide mirror. Doing so could result in injury during an accident or deployment of the airbag.

⚠ CAUTION

Cleaning mirror

When cleaning the mirror, use a paper towel or similar material dampened with glass cleaner. Do not spray glass cleaner directly on the mirror. It may cause the liquid cleaner to enter the mirror housing.

Day/night rearview mirror (if equipped)

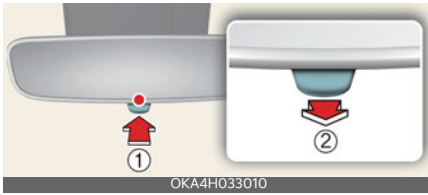

Make this adjustment before you start driving and while the day/night lever is in the day position (1).

Pull the day/night lever toward you (2) to reduce the glare from the headlights of the vehicles behind you during night driving.

Remember that you lose some rearview clarity in the night position.

Electric Chromic Mirror (ECM) (if equipped)

The ECM automatically controls the glare from the headlights of the vehicles behind you in nighttime or low light driving conditions.



The sensor mounted in the mirror senses the light level around the vehicle, and automatically controls the headlight glare from the vehicles behind you.

When the engine is running, the glare is automatically controlled by the sensor mounted in the rearview mirror.

⚠ CAUTION

Cleaning mirror

When cleaning the mirror, use a paper towel or similar material dampened with glass cleaner. Do not spray glass cleaner directly on the mirror. It may cause the liquid cleaner to enter the mirror housing.

Outside rearview mirror

Your vehicle is equipped with both left-side and right side outside rearview mirrors.

Be sure to adjust the mirror angles before driving.

The mirrors can be adjusted remotely with the control levers or remote switch, depending on the type of mirror control installed. The mirror heads can be folded back to prevent damage in an automatic car wash or when passing through a narrow street.

* NOTICE

Rearview mirrors

- The right outside rearview mirror is convex. Objects seen in the mirror are closer than they appear.
- Use your interior rearview mirror or direct observation to determine the actual distance of following vehicles when changing lanes.

⚠ CAUTION

Do not scrape ice off the mirror face; this may damage the surface of the glass. If ice restricts the movement of the mirror, do not force the mirror for adjustment. To remove ice, use a deicer spray, or a sponge or soft cloth with warm water. If the mirror is jammed with ice, do not adjust the mirror by force. Use an

approved spray deicer (not radiator anti-freeze) to release the frozen mechanism or move the vehicle to a warm place and allow the ice to melt.

⚠ WARNING

Do not adjust or fold the outside rearview mirrors while the vehicle is moving. This could result in loss of control, and an accident which could cause DEATH, SERIOUS INJURY, or property damage.

Adjusting the outside rearview mirrors

The electric remote control mirror switch allows you to adjust the position of the left and right outside rearview mirrors.

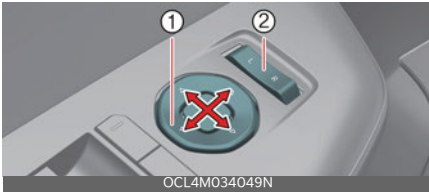

Adjusting the rearview mirrors:

1. Move the R or L switch (2) to select the right side mirror or the left side mirror.
2. Press a corresponding point on the mirror adjustment control (1) to position the selected mirror up, down, left or right.

⚠ CAUTION

- The mirrors stop moving when they reach the maximum adjusting angles, but the motor continues to operate while the switch is pressed. Do not press the switch longer than necessary, the motor may be damaged.
- Do not adjust the outside rearview mirror by hand. Doing so may damage the parts.

- When the mirror control, press exactly “▲” (2) marking area. Otherwise, the mirror will move to unintended direction or malfunction.

Folding the outside rearview mirror

To fold the outside rearview mirror, grasp the housing of the mirror and then fold it toward the rear of the vehicle.



Reverse parking aid function (if equipped)

When you move the shift lever to the R (Reverse) position, the outside rearview mirror(s) will rotate downwards to aid with driving in reverse.

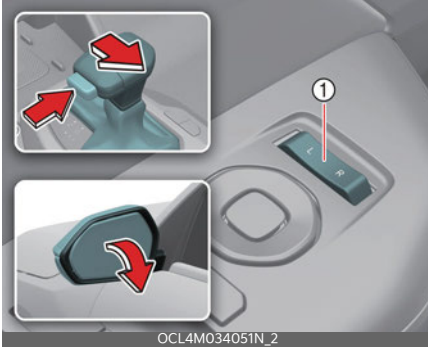

The position of the outside rearview mirror switch (1) determines whether or not the mirrors will move:

Left/Right: When either the L (Left) or R (Right) switch is selected, both outside rearview mirrors will move.

Neutral: When neither switch is selected, the outside rearview mirrors will not move.

The outside rearview mirrors will automatically revert to their original positions if any of the following occur:

- The ignition switch or ENGINE START/STOP button is placed to either the OFF position or the ACC position.
- The shift lever is moved to any position except R (Reverse).
- The remote control outside rearview mirror switch is not selected.

Instrument cluster

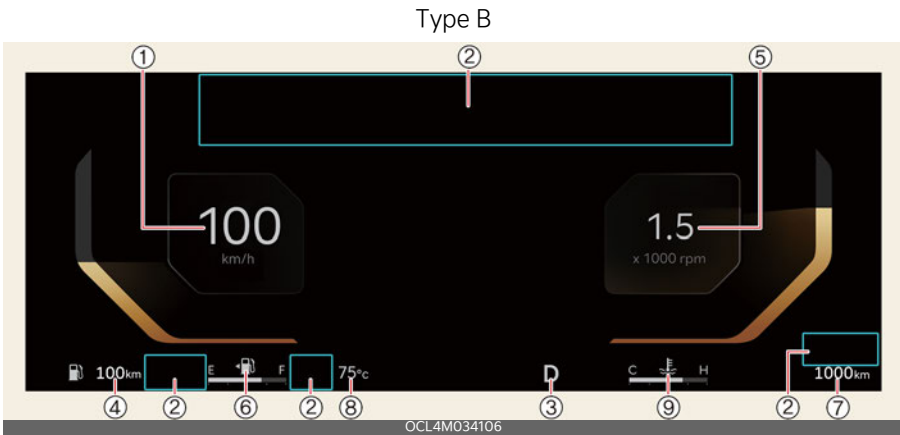
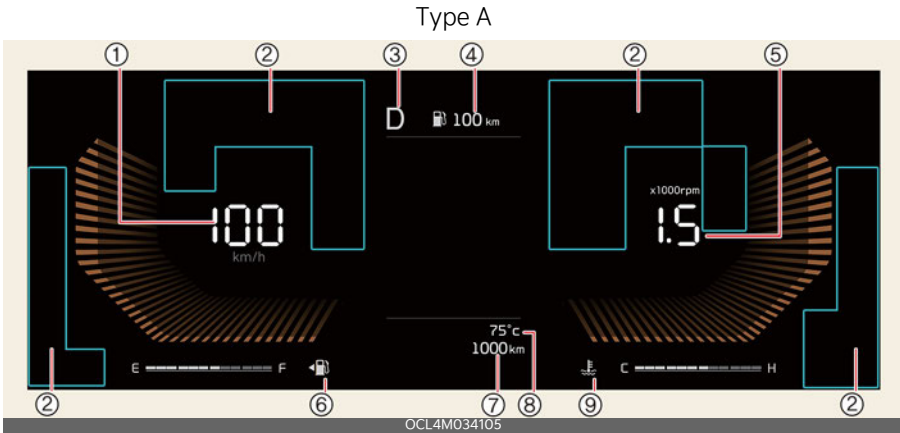

* The actual cluster in your Kia may differ from the illustration.

- 1 Speedometer
- 2 Warning and indicator lights
- 3 Transmission shift indicator (if equipped)
- 4 Distance to empty
- 5 Tachometer
- 6 Fuel gauge
- 7 Odometer
- 8 Outside temperature gauge
- 9 Engine coolant temperature gauge

Adjusting instrument cluster illumination

The brightness of the instrument panel illumination is changed by pressing the illumination control button ("+" or "-") when the ENGINE START/STOP button is ON, or the taillight are turned on.



⚠ WARNING

Never adjust the instrument cluster while driving. This could result in loss of control and lead to an accident that may cause serious injury, death or property damage.

Gauges

The gauges display various information such as the speed of the vehicle, and so on.

Speedometer

Type A

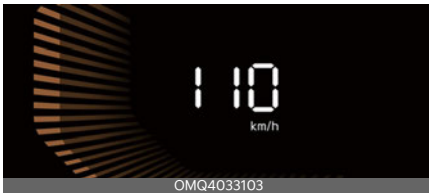

Type B

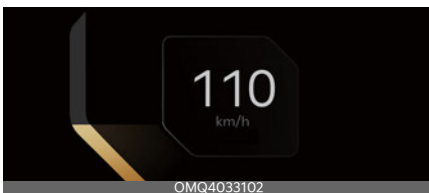

The speedometer indicates the speed of the vehicle and is calibrated in miles per hour (mph) and kilometers per hour (km/h).

Tachometer

Type A

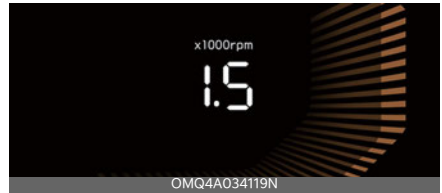

Type B

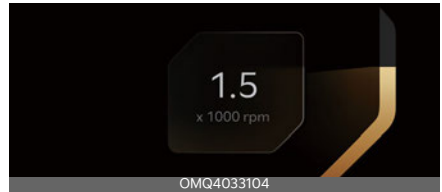

The tachometer indicates the approximate number of engine revolutions per minute (rpm).

Use the tachometer to select the correct shift points and to prevent lugging and/or over-revving the engine.

⚠ CAUTION

Do not operate the engine within the tachometer's RED ZONE. This may cause severe engine damage.

Engine coolant temperature gauge

Type A

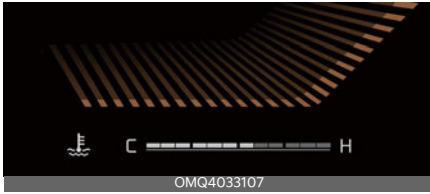

Type B



This gauge indicates the temperature of the engine coolant when the ENGINE START/STOP button is ON.

⚠ CAUTION

If the gauge pointer moves beyond the normal range area (between the C-H) toward the "H" (Hot) position, it indicates overheating that may damage the engine.

Do not continue driving with an overheated engine. If your vehicle overheats, refer to "If the engine overheats" on page 7-6.

⚠ WARNING

Never remove the engine coolant reservoir cap when the engine is hot. The engine coolant is under pressure and could severely burn you. Wait until the engine is cool before adding coolant to the reservoir.

⚠ WARNING

Engine coolant reservoir cap



Do not remove the engine coolant reservoir cap when the engine is hot. This may result in coolant being blown out of the opening and cause serious burns.

Fuel gauge

Type A

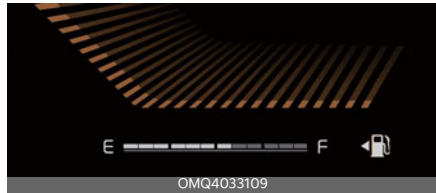

Type B

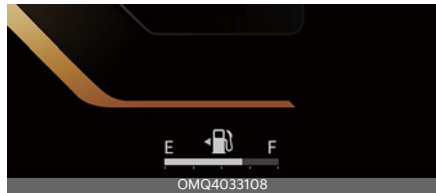

This gauge indicates the approximate amount of fuel remaining in the fuel tank.

⚠ CAUTION

- If the shift gear is not P (Park) or N (Neutral) during refueling, the refueling may not be recognized and the fuel amount and distance to empty may be displayed abnormally.
- More than 6 liters(1.6 gallons) of fuel must be refilled for the vehicle to change the fuel gauge.

*** NOTICE**

- The fuel tank capacity can be found in "Recommended lubricants and capacities" on page 9-9.
- The fuel gauge is supplemented by a low fuel warning light, which will appear when the fuel tank is nearly empty.
- On inclines or curves, the fuel gauge pointer may fluctuate or the low fuel warning light may come on earlier than usual due to the movement of fuel in the tank.

▲ WARNING

Fuel Gauge

Running out of fuel can expose vehicle occupants to danger.

You must stop and obtain additional fuel as soon as possible after the warning light illuminates or when the gauge indicator comes close to the "E" (Empty) level.

▲ CAUTION

Avoid driving with an extremely low fuel level. Running out of fuel could cause the engine to misfire, which could damage the catalytic converter.

*** NOTICE**

The fuel display may not be accurate if the vehicle is on an incline.

Odometer

Type A

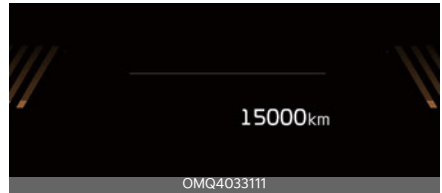

Type B

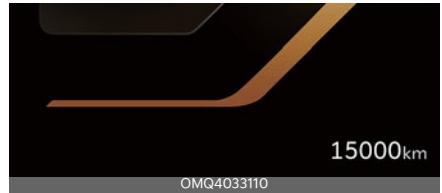

The odometer Indicates the total distance that the vehicle has been driven and should be used to determine when periodic maintenance should be performed.

- Odometer range: 999,999 miles or 1,599,999 km.

Distance to empty

Type A

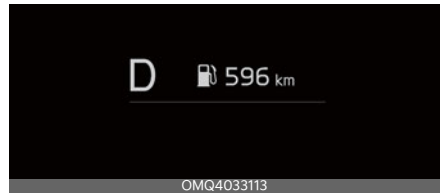

Type B

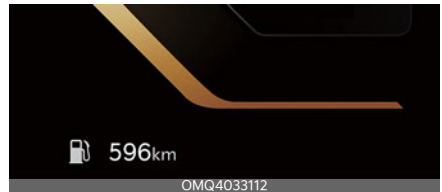

- The distance to empty is the estimated distance the vehicle can be driven with the remaining fuel.
 - Distance range: 1-9,999 miles or 1-9,999 km.
- If the estimated distance is below 1 km (1 mile), the trip computer will display "---" as distance to empty.

⚠ CAUTION

If the shift gear is not P (Park) or N (Neutral) during refueling, the refueling may not be recognized and the fuel amount and distance to empty may be displayed abnormally.

*** NOTICE**

- If the vehicle is not on level ground or the battery power has been interrupted, the distance to empty function may not operate correctly.
- The distance to empty may differ from the actual driving distance as it is an estimate of the available driving distance.
- The trip computer may not register additional fuel if less than 1.6 gallons (6 liters) of fuel are added to the vehicle.
- The fuel economy and distance to empty may vary significantly based on driving conditions, driving habits, and condition of the vehicle.

Outside temperature gauge

Type A

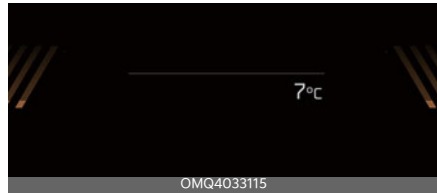

Type B



This gauge indicates the current outside air temperatures by 1 °C (1 °F).

- Temperature range: -40 °C - 60 °C (-40 °F - 140 °F)

The outside temperature on the display may not change immediately like a regular thermometer to prevent the driver from being inattentive.

To change the temperature unit (from °C to °F or from °F to °C), select **Setup** → **General** → **Units** → **Temperature Unit** from the infotainment system.

Transmission shift indicator

Transmission shift indicator displays gear information depending on your vehicle's transmission type.

Automatic transmission shift indicator

Type A



Type B

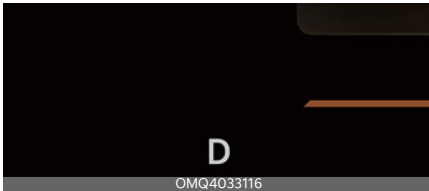

This indicator displays which automatic transmission shift lever is selected.

- Park: P
- Reverse: R
- Neutral: N
- Drive: D

LCD display

The LCD display modes can be changed by using the control buttons.

LCD Display Control



Switch	Control	Action
Mode (1) 	Short Press	Changing view modes
Up/Down (2) 	Short Roll	Searching Utility information
OK (2)	Short Press	Operating additional functions
	Long Press	Resetting menu information

LCD display modes

View	Description
Driving Assist view	Displays information related to Driver assistance system
Navigation view	Displays information related to navigation system
Utility information view	Displays information related to driving, warning, etc.

* NOTICE

- The Items displayed in the LCD display mode may differ depending on which functions are applicable to your vehicle your vehicle.

Driving assist view



This mode displays the state of:

- Lane Keeping Assist
- Blind-Spot Collision-Avoidance Assist
- Smart Cruise Control
- Lane Following Assist
- Highway Driving Assist

Navigation view

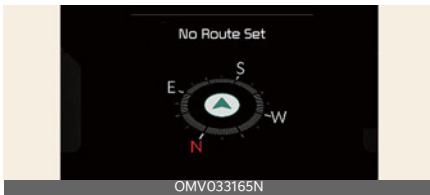

This mode displays the Navigation status.

Utility information view

Current Driving Info

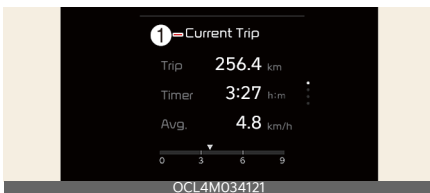

1: Current Trip

The driver's door is opened after turning off the vehicle or the vehicle is turned on after 3 minutes have passed, the Drive Info screen will reset.

Fuel economy



1: Current Trip

Average Fuel Economy

- The average fuel economy is calculated by the total driving distance and fuel consumption since the last average fuel economy reset.
 - Fuel economy range: 0 - 99.9 MPG or L/100km, km/L
- The average fuel economy can be reset both manually and automatically.

* NOTICE

The average fuel economy is not displayed for more accurate calculation if the vehicle does not drive more than 10 seconds or 300 meters (0.19 miles) after the ENGINE START/STOP button is turned to ON.

Instant Fuel Economy

- This mode displays the instant fuel economy during the last few seconds when the vehicle speed is more than 8 km/h (5 MPH).
 - Fuel economy range: 0-50 MPG or 0-30 L/100km, km/L

Since refueling Info

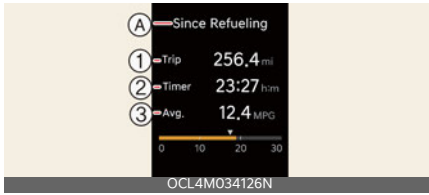

A: Sine Refueling

1 Trip

2 Timer

3 Avg.

The information after charging.

To manually reset the information, press and hold the OK button when viewing the **Sine Refueling**.

Accumulated Info



1: Since Last Reset

The information is accumulated starting from the last reset.

To manually reset the information, press and hold the OK button when viewing the **Since Last Reset**.

* NOTICE

- The vehicle must be driven for a minimum of 300 meters (0.19 miles) since the last cycle before the accumulated driving information is recalculated.
- The average energy economy is not displayed for more accurate calculation if the vehicle is not drive more than 10 seconds or 50 meters (0.03

miles) since the ENGINE START/STOP button was turned to on.

Master warning mode



1: Check headlamp LED

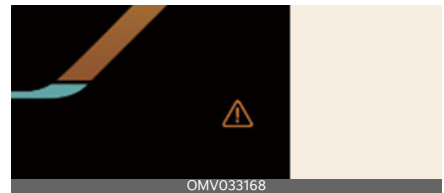

This mode informs you of the following situations:

- Driver assistance system malfunction, limitation or radar/camera blockage
- LED headlamp malfunction
- Lamp malfunction
- TPMS failure, low tire pressure, etc.

A Master Warning icon (⚠) will appear in the lower right corner on the LCD display. If the warning situation is resolved, the master warning light will be turned off and the Master Warning icon will disappear.

Other view modes

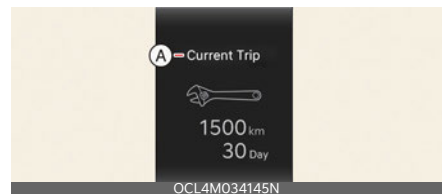

A : Service Interval

To reset the service interval, select **Setup** → **Vehicle** → **Cluster** → **Service Interval** → **Reset**.

Driver Assistance settings (infotainment system) (if equipped)



Select **Setup** → **Vehicle** → **Driver Assistance** on the infotainment system screen to set the Driver Assistance function.

- Driver Assistance
 - Driving Convenience
 - Speed limit
 - Warning Methods
 - Driving Safety
 - Parking Safety

* INFORMATION

The infotainment system may change after software updates. For more information, refer to the manual provided in the infotainment system and the quick reference guide.

LCD display messages

Door, hood, trunk, sunroof open

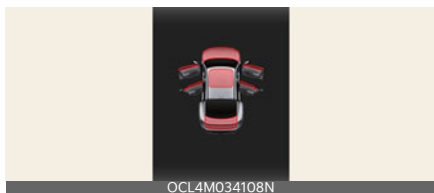

- This warning is displayed indicating which door, the hood, the trunk or the sunroof is open.

* NOTICE

Before driving the vehicle, you should confirm that the door/hood/trunk/sunroof is fully closed. Also, check there is no door/hood/trunk/sunroof open warning light or message displayed on the instrument cluster.

Lights mode

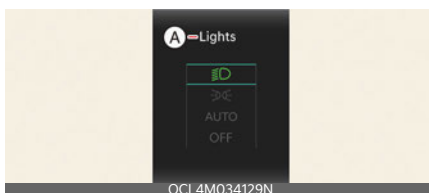

A: Lights

This indicator displays which exterior light is selected using the lighting control.

Wiper mode



A: Front Wiper

This indicator displays which wiper speed is selected using the wiper control.

Engine Overheated

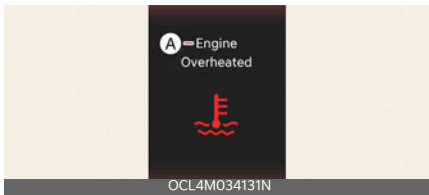

A: Engine Overheated

- This warning message appears when the engine coolant temperature is above 120 °C (248 °F). This means that the engine is overheated and may be damaged.

* If your vehicle has overheated, refer to "If the engine overheats" on page 7-6.

Low engine oil

- This warning message appears when the engine oil level is insufficient.
- Refill the engine oil.

* For more details, refer to "Engine oil and filter" on page 8-15.

⚠ WARNING

When the engine oil level warning light occurs, it is necessary to check whether maintenance schedule (Engine oil replacement) in owner's manual has been followed before replenishing the oil, and if not followed, the engine oil must be replaced first.

Engine oil change due soon. Reset oil life after oil change

- This warning message appears when the remaining engine oil life reaches 5% or below.
- Replace engine oil from an authorized Kia dealer. After that, select **Setup** → **Vehicle** → **Convenience** → **Oil**

Change Reminder from Settings menu on the infotainment system screen to reset the remaining oil life.

* For more details, refer to "Engine oil and filter" on page 8-15.

*** INFORMATION**

The infotainment system may change after software updates. For more information, refer to the user's manual provided in the infotainment system and the quick reference guide.

Engine oil change due now. Reset oil life after oil change

- This warning message appears when the remaining engine oil life reaches 1% or below.
- Replace engine oil immediately from an authorized Kia dealer. After that, select **Setup** → **Vehicle** → **Convenience** → **Oil Change Reminder** from Settings menu on the infotainment system screen to reset the remaining oil life.

* For more details, refer to "Engine oil and filter" on page 8-15.

*** INFORMATION**

The infotainment system may change after software updates. For more information, refer to the user's manual provided in the infotainment system and the quick reference guide.

Low key battery (for smart key system)

- This warning message appears if the battery of the smart key is discharged when the ENGINE START/STOP button changes to the OFF position.

Key not in vehicle (for smart key system)

- This warning message appears if the smart key is not in the vehicle when you press the ENGINE START/STOP button.
- It means that you should always have the smart key with you.

Key not detected (for smart key system)

- This warning message appears if the smart key is not detected when you press the ENGINE START/STOP button.

Shift to P or N to start engine (for smart key system)

- This warning message appears if you try to start the engine with the shift lever not in the P (Park) or N (Neutral) position.

Press brake pedal to start engine (for smart key system)

- This warning message appears if the ENGINE START/STOP button changes to the ACC position twice by pressing the button repeatedly without depressing the brake pedal.
- It means that you should depress the brake pedal to start the engine.

Battery discharging due to external electrical devices

The vehicle can detect self-discharge of the battery due to over-current that is generated by unauthorized electrical devices such as dashboard camera (dash cam) mounting during parking.

If the warning continues even after external electrical devices are removed, have your vehicle inspected by an authorized Kia dealer.

Press start button again (for smart key system)

- This warning message appears if you cannot operate the ENGINE START/STOP button when there is a problem with the ENGINE START/STOP button system.
- It means that you could start the engine by pressing the ENGINE START/STOP button once more.
- If the warning appears each time you press the ENGINE START/STOP button, have the vehicle inspected by an authorized Kia dealer.

Press start button with key (for smart key system)

- This warning message appears if you press the ENGINE START/STOP button while the warning message "Key not detected" is illuminating.
- At this time, the immobilizer indicator light blinks.

Headlights are off

- This warning message appears if the headlights are off when the surrounding is dark.

Warning and indicator lights

The warning light and indicator light indicate a situation where the driver should be careful and whether the various functions are activated.

Warning lights

The warning light indicates situations that require the driver to pay attention.

* NOTICE

Warning lights

Make sure that all warning lights are OFF after starting the engine. If any light is still ON, this indicates a situation that needs attention.

Airbag warning light

This warning light appears:

- Once you set the ENGINE START/ STOP button to the ON position.
 - It appears for approximately 6 seconds and then goes off.
- When there is a malfunction with the SRS.
 - In this case, have the vehicle inspected by an authorized Kia dealer.

Seat belt warning light

This warning light informs the driver that the seat belt is not fastened.

* For more details, refer to "Seat belts" on page 3-16.

Parking brake & brake fluid warning light

This warning light appears:

- Once you set the ENGINE START/ STOP button to the ON position.
 - It appears for approximately 3 seconds
 - It remains on if the parking brake is applied.
- When the parking brake is applied.
- When the brake fluid level in the reservoir is low.
 - If the warning light appears with the parking brake released, it indicates the brake fluid level in reservoir is low.

If the brake fluid level in the reservoir is low:

1. Drive carefully to the nearest safe location and stop your vehicle.
2. With the engine stopped, check the brake fluid level immediately and add fluid as required (For more details, refer to "Brake fluid" on page 8-19). Then check all brake components for fluid leaks. If any leak on the brake system is found, the warning light remains on, or the brakes do not operate properly, do not drive the vehicle.

Have your Kia towed to an authorized Kia dealer and inspected.

Dual-diagonal braking system

Your vehicle is equipped with dual-diagonal braking systems. This means you still have braking on two wheels even if one of the dual systems should fail.

With only one of the dual systems working, more than normal pedal travel and greater pedal pressure are required to stop the vehicle.

The vehicle will not stop in as short a distance with only a portion of the brake system working.

If the brakes fail while you are driving, shift to a lower gear for additional engine braking and stop the vehicle as soon as it is safe to do so.

*** NOTICE**

Parking Brake & Brake Fluid Warning Light

Driving the vehicle with a warning light ON is dangerous. If the Parking Brake & Brake Fluid Warning Light appears with the parking brake released, it indicates that the brake fluid level is low.

Have your Kia inspected by an authorized Kia dealer.

Anti-lock Brake System (ABS)

warning light ABS / 

This warning light appears:

- Once you set the ENGINE START/ STOP button to the ON position.
 - It appears for approximately 3 seconds and then goes off.
- When there is a malfunction with the ABS (The normal braking system will still be operational without the assistance of the anti-lock brake system). Have the vehicle inspected by an authorized Kia dealer.

Electronic Brake Force Distribution (EBD) system warning light



These two warning lights appear at the same time while driving:

- When the ABS and regular brake system are not working, have your vehicle inspected by an authorized Kia dealer.

⚠ WARNING

EBD System Warning Light

When both ABS and Parking Brake & Brake Fluid Warning Lights are on, the brake system will not work normally and you may experience an unexpected and dangerous situation during sudden braking.

In this case, avoid high speed driving and abrupt braking.

Have your vehicle inspected by an authorized Kia dealer as soon as possible.

Motor Driven Power Steering (MDPS) warning light 

This warning light appears:

- Once you set the ENGINE START/ STOP button to the ON position.
 - It appears for approximately 3 seconds and then goes off.
- When there is a malfunction with the MDPS. In this case, have the vehicle inspected by an authorized Kia dealer.

Charging system warning light



This warning light appears:

- Once you set the ENGINE START/STOP button to the ON position.
- When there is a malfunction with either the alternator or electrical charging system.

If there is a malfunction with either the alternator or electrical charging system:

1. Drive carefully to the nearest safe location and stop your vehicle.
2. Turn the engine off and check the alternator drive belt for looseness or breakage.

In this case, have the vehicle inspected by an authorized Kia dealer.

Forward Safety warning light

This indicator light appears:

- Once you set the ENGINE START/STOP button to the ON position.
 - It appears for approximately 3 seconds and then goes off.
- Yellow: When Forward Safety of Forward Collision-Avoidance Assist is deselected, disabled, or a malfunction is detected.

If the yellow warning light remains on after the sensor has been uncovered or unblocked when Forward Safety is set, have your vehicle be inspected by an authorized KIA dealer.

This warning light blinks:

- Red: When Forward Safety or Forward Cross-Traffic Safety function is operating.
- * For more details, refer to "Forward Collision-Avoidance Assist (FCA) (Sensor Fusion) (if equipped)" on page 6-4.

Emergency steering warning light (if equipped)

This warning light appears:

- Yellow:
 - When the ENGINE START/STOP button is in the ON position. It appears for approximately 3 seconds and then goes off.
 - When Forward/Side Safety of Forward Collision-Avoidance Assist is Off/Disabled/Malfunction. It appears continuously.
- Red:
 - When Forward/Side Safety of Forward Collision-Avoidance Assist is operating. It appears blinking.

* For more details, refer to "Forward Collision-Avoidance Assist (FCA) (Sensor Fusion) (if equipped)" on page 6-4.

Electronic Parking Brake (EPB) warning light

This warning light appears:

- Once you set the ENGINE START/STOP button to the ON position.
 - It appears for approximately 3 seconds and then goes off.
- When there is a malfunction with the EPB.

In this case, have the vehicle inspected by an authorized Kia dealer.

*** NOTICE**

Electronic Parking Brake (EPB) Warning Light

The EPB Warning Light may appear when the Electronic Stability Control (ESC) Indicator Light comes on to indicate that the ESC is not working properly (This does not indicate malfunction of the EPB).

Malfunction Indicator Lamp (MIL)



This warning light appears:

- When you set the ENGINE START/ STOP button to the ON position.
 - The malfunction indicator light appears for about 3 seconds and then goes off.
- Whenever there is a malfunction with either the emission control system or the engine or the vehicle powertrain. In this case, have the vehicle inspected by an authorized Kia dealer.

⚠ CAUTION

Malfunction Indicator Lamp (MIL)

- Driving with the Malfunction Indicator Lamp (MIL) on may cause damage to the emission control systems which could affect drivability and/or fuel economy.
- If the enhanced engine protection system becomes activated due to lack of engine oil, engine power will be limited. If such condition continues repeatedly, the Malfunction Indicator Lamp will appear.

⚠ CAUTION

If the Malfunction Indicator Lamp (MIL) appears, potential catalytic converter damage is possible which could result in loss of engine power. In this case, have the vehicle inspected by an authorized Kia dealer.

Engine oil pressure warning light



This warning light appears:

- Once you set the ignition switch or ENGINE START/STOP Button to the ON position.
 - It remains on until the engine is started.
- When the engine oil pressure is low.

If the engine oil pressure is low:

- Drive carefully to the nearest safe location and stop your vehicle.
- Turn the engine off and check the engine oil level (For more details, refer to "Engine oil and filter" on page 8-15). If the level is low, add oil as required.
- If the warning light remains on after adding oil or if oil is not available, have the vehicle inspected by an authorized Kia dealer. Continued driving with the warning light on may cause engine failure.

*** NOTICE**

- When engine oil pressure decreases due to insufficient engine oil, etc., the Engine Oil Pressure warning light will appear.
- The enhanced engine protection system which limits engine power will be activated. When the engine oil pres-

sure is restored, the warning light and the enhanced engine protection system will turn off after the engine is restarted.

Low fuel level warning light

This warning light appears:

- When the fuel tank is nearly empty.

If the fuel tank is nearly empty:

- Add fuel as soon as possible.

CAUTION

Low Fuel Level

Driving with the Low Fuel Level warning light on or with the fuel level below "E" can cause the engine to misfire and damage the catalytic converter.

Master warning light

This indicator light appears:

- LED headlamp malfunction (if equipped)
- Lamp malfunction
- High Beam Assist malfunction (if equipped)

To identify the details of the warning look at the LCD display.

If the warning situation is solved, the master warning light will turn off.

Low Tire Pressure warning light



This warning light appears:

- Once you set the ENGINE START/ STOP button to the ON position.
 - It appears for approximately 3 seconds and then goes off.
- When one or more of your tires are significantly under inflated. (The location of the underinflated tires are displayed on the LCD display).
- * For more details, refer to "Tire Pressure Monitoring System (TPMS)" on page 7-7.

This warning light remains on after blinking for approximately 70 seconds or repeats blinking on and off at the intervals of approximately 3 seconds:

- When there is a malfunction with the TPMS.
 - Have your vehicle inspected by an authorized Kia dealer as soon as possible.
- * For more details, refer to "Tire Pressure Monitoring System (TPMS)" on page 7-7.

WARNING

Low tire pressure

- Significantly low tire pressure makes the vehicle unstable and can contribute to loss of vehicle control and increased braking distances.
- Continued driving on low pressure tires will cause the tires to overheat and fail.

⚠ WARNING

Safe Stopping

- The TPMS cannot alert you to severe and sudden tire damage caused by external factors.
- If you notice any vehicle instability, immediately take your foot off the accelerator pedal, apply the brakes gradually with light force, and slowly move to a safe position off the road.

LED Headlamp warning light  (if equipped)

This warning light appears:

- Once you set the ENGINE START/STOP button to the ON position.
 - It appears for approximately 3 seconds and then goes off.
- When there is a malfunction with the LED headlamp.

Have your vehicle inspected by an authorized Kia dealer.

This warning light blinks:

- When there is a malfunction with a LED headlamp related part.

Have your vehicle inspected by an authorized Kia dealer.

⚠ CAUTION

LED Headlamp Warning Light

Continuous driving with the LED Headlamp Warning Light on or blinking can reduce LED headlamp (low beam) life.

Door Ajar Warning Light 

This warning light appears:

When a door is not closed securely.

Washer Fluid Warning Light 

This warning light appears:

- When the washer fluid level in the reservoir is nearly empty.
You should refill the washer fluid.

Inattentive Driving Warning light 

This indicator light appears:

- When the ENGINE START/STOP Button is in the ON position. It appears for about 3 seconds and then goes off.
- Yellow: When Driver Attention Warning is disabled or a malfunction is detected. If the yellow indicator light remains on after the front view camera has been uncovered or unblocked, have your vehicle inspected by an authorized Kia dealer.

This indicator light blinks:

- Yellow: Driver Attention Warning recommends that you take a break.

* For more details, refer to "Driver Attention Warning (DAW)" on page 6-51.

Indicator lights

Electronic stability control (ESC) indicator light

This indicator light appears:

- Once you set the ENGINE START/STOP button to the ON position.
 - It appears for approximately 3 seconds and then goes off.
- When there is a malfunction with the ESC system.
In this case, have your vehicle inspected by an authorized Kia dealer.

This indicator light blinks:

- While the ESC is operating.
- * For more details, refer to "Electronic Stability Control (ESC) system" on page 5-32.

Electronic stability control (ESC) OFF indicator light

This indicator light appears:

- Once you set the ENGINE START/STOP button to the ON position.
 - It appears for approximately 3 seconds and then goes off.
- When you deactivate the ESC system by pressing the ESC OFF button.
- * For more details, refer to "Electronic Stability Control (ESC) system" on page 5-32.

Immobilizer indicator light (without smart key)

This indicator light appears:

- When the vehicle detects the immobilizer in your key properly while the ignition switch is ON.
 - You can start the engine.
 - The indicator light goes off after starting the engine.

This indicator light blinks:

- When there is a malfunction with the immobilizer system.
Have the vehicle inspected by an authorized Kia dealer.

Immobilizer indicator light (With Smart Key)

This indicator light appears for up to 30 seconds:

- When the vehicle detects the smart key in the vehicle properly while the ENGINE START/STOP button is ACC or ON.
 - At this time, you can start the engine.
 - The indicator light goes off after starting the engine.

This indicator light blinks for a few seconds:

- When the smart key is not in the vehicle.
 - At this time, you cannot start the engine.

This indicator light appears for 2 seconds and goes off:

- When the vehicle cannot detect the smart key which is in the vehicle while the ENGINE START/STOP button is ON.

In this case, have your vehicle inspected by an authorized Kia dealer.

This indicator light blinks:

- When the battery of the smart key is weak.
 - At this time, you cannot start the engine. However, you can start the engine if you press the ENGINE START/STOP button with the smart key. (For more details, refer to "Immobilizer System" on page 4-12).
- When there is a malfunction with the immobilizer system.

In this case, have your vehicle inspected by an authorized Kia dealer.

Turn signal indicator light 

This indicator light blinks:

- When you turn the turn signal light on. If any of the following occurs, there may be a malfunction with the turn signal system. In this case, have your vehicle inspected by an authorized Kia dealer.
- The indicator light does not blink but appears.
- The indicator light blinks more rapidly.
- The indicator light does not appear at all.

Low beam indicator light 

This indicator light appears:

- When the headlights are on.

High beam indicator light 

This indicator light appears:

- When the headlights are on and in the high beam position.
- When the turn signal lever is pulled into the Flash-to-Pass position.

High Beam Assist indicator light



This warning light appears:

- When the high beam is on with the light switch in the AUTO light position.
- If your vehicle detects oncoming or preceding vehicles, High Beam Assist will switch the high beam to low beam automatically.

* For more details, refer to "High Beam Assist (HBA)" on page 4-86.

Light ON indicator light 

This indicator light appears:

- When the tail lights or headlights are on.

Front fog indicator light  (if equipped)

This indicator light appears:

- When the front fog lights are on.

Lane Safety indicator light

This indicator light appears:

- Once you set the ENGINE START/STOP button to the ON position.
 - It appears for approximately 3 seconds and then goes off.
- Gray: When Lane Keeping Assist operating conditions are not satisfied.
- Green: When Lane Keeping Assist operating conditions are satisfied.
- Yellow: When Lane Safety is disabled, or a malfunction is detected.

If the yellow warning light remains on after the sensor has been uncovered or unblocked when Lane Safety is set, have your vehicle be inspected by an authorized Kia dealer.

The indicator light blinks:

- Green: When Lane Keeping Assist is operating.
- * For more details, refer to "Lane Keeping Assist (LKA)" on page 6-25.

AUTO HOLD indicator light

(AUTO HOLD)

This indicator light appears:

- White: When you activate the auto hold system by pressing the AUTO HOLD button.
- Green: When you stop the vehicle completely by depressing the brake pedal with the auto hold system activated.
- Yellow: When there is a malfunction with the auto hold system.
In this case, have your vehicle inspected by an authorized Kia dealer.

* For more details, refer to "AUTO HOLD" on page 5-28.

Drive mode indicator light (SPORT/MY/SNOW) (if equipped)

This indicator light appears:

- When you select each mode as drive mode.

For more details, refer to "Drive mode integrated control system" on page 5-37.

Intelligent Speed Limit Assist indicator light

This indicator light appears:

- When the ENGINE START/STOP Button is in the ON position. It appears for about 3 seconds and then goes off.
- Yellow: When Intelligent Speed Limit Assist is off, disabled, or a malfunction is detected.
- While the Intelligent Speed Limit Assist system is "AUTO HOLD" on page 5-28 "AUTO HOLD" on page 5-28 "AUTO HOLD" on page 5-28 "AUTO HOLD" on page 5-28 in operation, indicates the speed limit and shows the speed limit in red when the vehicle is exceeding the speed limit.

* For more details, refer to "Intelligent Speed Limit Assist (ISLA)" on page 6-46.

Lane Following Assist indicator



This indicator light appears:

Lane Following Assist indicator will appear when you turn Lane Following

Assist on by pressing Lane Driving Assist button.

If there is a problem with the function, the yellow Lane Following Assist indicator will appear.

* For more details, refer to "Lane Following Assist (LFA)" on page 6-75.

Lighting

This vehicle is equipped with a variety of lights to illuminate the interior and exterior of the vehicle.

CAUTION

To prevent the battery from being discharged, do not leave the headlight and interior light on for a prolonged time while the engine is not running.

Battery saver function

The purpose of this feature is to prevent the battery from being discharged if the lights are left in the ON position. The system automatically shuts off the position lamps after the engine is off and the driver's door is opened.

However, the position lamps stay ON even when the driver-side door is opened if the light switch is operated after the engine is turned off.

If necessary, to keep the lamps on turn the position lamps OFF and ON again using the headlamp switch on the steering column after the engine is turned off.

Headlamp delay function (if equipped)

If you place the ignition switch or ENGINE START/STOP button in the ACC or OFF position with the headlamps ON, the headlamps (and/or position lamps) remain on for about 5 minutes. However, with the engine off if the driver's door is opened and closed, the headlamps (and/or position lamps) are turned off after 15 seconds.

The headlamps (and/or position lamps) can be turned off by pressing the lock button on the smart key twice or turning the light switch to the OFF or AUTO position. However, if you turn the light

switch to the AUTO position when it is dark outside, the headlamps will not be turned off.

You can activate or deactivate the Headlamp Delay function from the Settings menu on the infotainment system screen. If your vehicle is equipped with an infotainment system, you can learn how to set up on the website via QR code in the infotainment quick reference guide.

*** INFORMATION**

The infotainment system may change after software updates. For more information, refer to the user's manual provided in the infotainment system and the quick reference guide.

*** NOTICE**

If the driver exits the vehicle through another door besides the driver door, the battery saver function does not operate and the headlamp delay function does not turn OFF automatically.

This may cause the battery to discharge. To avoid battery discharge, turn OFF the headlamps manually from the headlamp switch before exiting the vehicle.

Daytime Running Light (DRL)

The Daytime Running Light (DRL) can make it easier for others to see the front of your vehicle during the day.

The DRL can be helpful in many different driving conditions, and it is especially helpful after dawn and before sunset.

The DRL will turn the dedicated lamp OFF when:

1. The headlamps are ON.
2. The vehicle is off.
3. The front fog light is on. (if equipped)

4. Engaging the parking brake.

Automatic Low beam light

Even if the light switch is in the OFF position, the low beam headlights, taillights and the low beam indicator light turns ON automatically to provide better safety during low light environment.

The low beam headlights, taillight and the low beam indicator light turns ON when the outside brightness is below 1000 lux.

The Automatic low beam light will deactivate when:

- Engaging the parking brake.
- Gear is in P (Parking) position.

Lighting control

The light switch has a headlight and a position lamp position.



To operate the lights, turn the knob at the end of the control lever to one of the following positions:

1. OFF position
2. Auto light position
3. Position & Tail lamp
4. Headlight position

Position & Tail lamp



When the light switch is in the position lamp position, the front position lamp and auxiliary lamp (if equipped), tail, license light will turn ON.

*** NOTICE**

Auxiliary lamp will be ON only in position lamp  condition.

Headlight (Low Beam) 



When the light switch is in the headlight position, headlight (low beam), tail, license light will turn ON.

*** NOTICE**

The ignition switch or ENGINE START/STOP button must be in the ON position to turn on the headlights.

Auto light



When the light switch is in the AUTO light position, the taillights and headlights will turn ON or OFF automatically depending on the amount of light outside the vehicle.

⚠ CAUTION

- Never place anything over the sensor (1) located on the instrument panel as this will ensure better auto-light system control.
- Don't clean the sensor using a window cleaner, the cleaner may leave a light film which could interfere with sensor operation.
- If your vehicle has window tint or other types of metallic coating on the front windshield, the Auto light system may not work properly.

Operating high beam 



To turn on the high beam headlight:

- Push the lever away from you.
The lever will return to its original position.
The high beam indicator will light when the headlight high beams are switched on.

⚠ WARNING

High beams

Do not use high beam when there are other vehicles in front of or approaching your vehicle. Using high beam could obstruct the other driver's vision.

To flash the headlights:

- Pull the lever towards you.



It will return to the normal (low beam) position when released. The headlight switch does not need to be on to use this flashing feature.

Operating turn signals and lane change signals



The ignition switch or ENGINE START/STOP button must be on for the turn signals to function.

To turn on the turn signals:

- Move the lever up or down (1).
The green arrow indicators on the instrument panel indicate which turn signal is operating.
They will self-cancel after a turn is completed. If the indicator continues to flash after a turn, manually return the lever to the OFF position.

To signal a lane change:

- Move the turn signal lever slightly and hold it in position (2).
The lever will return to the OFF position when released.

If an indicator stays on and does not flash or if it flashes abnormally, one of the turn signal bulbs may be burned out and will require replacement.

* NOTICE

If an indicator flash is abnormally quick or slow, a bulb may be burned out or have a poor electrical connection in the circuit. The bulb may require replacement.

One-touch lane change function

To activate a one-touch lane change function, move the turn signal lever slightly and then release it. The lane change signals will blink 3, 5 or 7 times. You can activate or deactivate the One Touch Turn Signal function or choose the number of blinking (3, 5, or 7) by selecting **Setup** → **Vehicle** → **Lights** → **One Touch Turn signal**.

* NOTICE

If the turn signal indicator stays on and does not flash, or if it flashes abnormally, a bulb may be burned out or have a poor electrical connection in the circuit. The bulb may require replacement.

Operating front fog light \neq (if equipped)

Fog lights are designed to provide improved visibility when visibility is poor due to fog, rain or snow, etc.



The fog lights will turn on when the fog light switch (1) is turned to the on position after the headlight is turned on.

To turn off the fog lights:

- Turn the fog light switch (1) to the OFF position.

*** NOTICE**

When in operation, the fog lights consume large amounts of vehicle electrical power. Only use the fog lights when visibility is poor.

- For more details on the precautions of the front view camera, refer to "Forward Collision-Avoidance Assist (FCA) (Sensor Fusion) (if equipped)" on page 6-4.

High Beam Assist (HBA)



High Beam Assist is a function that automatically adjusts the headlight range (switches between high beam and low beam) depending on the brightness of detected vehicles and certain road conditions.

Detecting sensor

Front view camera



The front view camera is used as a detecting sensor to detect ambient light and brightness while driving. Refer to the picture for the detailed location of the detecting sensor.

*** NOTICE**

- Always keep the front view camera in good condition to maintain optimal performance of High Beam Assist.

High Beam Assist setting

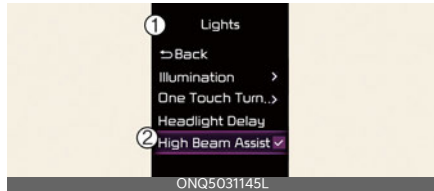

With the ENGINE START/STOP button in the ON position, select **Setup** → **Vehicle** → **Lights** → **High Beam Assist** from the Settings menu to turn on High Beam Assist and deselect to turn off the function.

⚠ WARNING

Change the Settings only after parking the vehicle at a safe location.

High Beam Assist operation

Display and control

- After selecting 'High Beam Assist' in the Settings menu, High Beam Assist will operate by following the procedure below.
 - Place the headlight switch in the AUTO position and push the headlight lever towards the instrument cluster. High Beam Assist indicator light will appear on the cluster and the function will be enabled.
 - When the function is enabled, high beam will turn on when vehicle speed is above 30 km/h (20 mph). When vehicle speed is below 20

km/h (12 mph), high beam will not turn on.

- The white High Beam  indicator light will appear on the cluster.
- When High Beam Assist is operating, if the headlight lever or switch is used, the function operates as follows:
 - If the headlight lever is pulled towards you when the high beam is off, the high beam will turn on without High Beam Assist canceled. When you let go of the headlight lever, the lever will move to the middle and the high beam will turn off.
 - If the headlight lever is pulled towards you when the high beam is on by High Beam Assist, low beam will be on and the function will turn off.
 - If the headlight switch is placed from AUTO to another position (headlight/position/off), High Beam Assist will turn off and the corresponding lamp will turn on.
- When High Beam Assist is operating, high beam switches to low beam if any of the following conditions occur:
 - When the headlight of an oncoming vehicle is detected.
 - When the tail lamp of a vehicle in front is detected.
 - When the headlight or tail lamp of a motorcycle or a bicycle is detected.
 - When the surrounding ambient light is bright enough that high beams are not required.
 - When streetlights or other lights are detected.

High Beam Assist malfunction and limitations

High Beam Assist malfunction

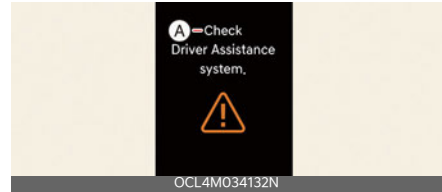

A: Check Driver Assistance system.

When High Beam Assist is not working properly, the 'Check High Beam Assist (HBA) system' warning message will appear and the Master warning light



will appear on the cluster. In this case, have High Beam Assist inspected by an authorized Kia dealer.

Limitations of High Beam Assist

High Beam Assist may not work properly in the following situations:

- Light from a vehicle is not detected because of lamp damage, or because it is hidden from sight, etc.
- Headlight of a vehicle is covered with dust, snow or water.
- A vehicle's headlights are off but the fog lamps are on and etc.
- There is a lamp that has a similar shape as a vehicle's lamp.
- Headlights have been damaged or not repaired properly.
- Headlights are not aimed properly.
- Driving on a narrow curved road, rough road, uphill or downhill.
- Vehicle in front is partially visible on a crossroad or curved road.
- There is a traffic light, reflecting sign, flashing sign or mirror ahead.

- There is a temporary reflector or flash ahead (construction area).
- The road conditions are poor such as being wet, iced or covered with snow.
- A vehicle suddenly appears from a curve.
- The vehicle is tilted from a flat tire or is being towed.
- Light from a vehicle is not detected because of exhaust fume, smoke, fog, snow, etc.

* NOTICE

- Depending on the instrument cluster specification or theme, images or colors may be displayed differently.
- For more details on the limitations of the front view camera, refer to "Forward Collision-Avoidance Assist (FCA) (Sensor Fusion) (if equipped)" on page 6-4.
- You can check it in the service message of the utility information view of the cluster display window.

⚠ WARNING

- High Beam Assist may not turn off high beams every time. This function is for your convenience only. It is the responsibility of the driver to always check the road conditions and adjust headlights appropriately, including by using the manual controls. for your safety.
- It may not operate for 15 seconds after the vehicle is started, or the front view camera is initialized or restarted.
- If the high beam assistance is not operated properly, switch the headlights manually.

Wipers and washers

The wipers and washers remove foreign substances from the windshield and rear window, helping to maintain visibility.



1 Wiper speed control

- MIST - Single wipe
- OFF - Off
- INT - Intermittent wipe
- LO - Low wiper speed
- HI - High wiper speed

2 Intermittent control wipe time adjustment

3 Wash with brief wipes

* NOTICE

If there is heavy accumulation of snow or ice on the windshield, do not drive and defrost the windshield for about 10 minutes, or until the snow and/or ice is removed before using the windshield wipers to ensure proper operation. If you do not remove the snow and/or ice before using the wiper and washer, it may damage the wiper and washer system.

* INFORMATION

If you operate the wipers while driving on snowy roads, the wipers may stop due to snow buildup on your windshield. This is normal and not a failure because it is one of our safety features to prevent vehicle accidents and wiper damage from overloading the wiper motor. If the wipers stop, remove snow accumulated

on the top or bottom of windshield before using them.

WARNING

Do not use the washer in freezing temperatures without first warming the windshield with the defrosters; the washer solution could freeze on the windshield and obscure your vision.

Operating windshield washers



1. Move the wiper speed control switch to the OFF position.
2. Pull the lever gently toward you to spray washer fluid on the windshield and to run the wipers 1-3 cycles. Use this function when the windshield is dirty. The spray and wiper operation will continue until you release the lever.

If the washer does not work, check the washer fluid level. If the fluid level is not sufficient, you will need to add appropriate non-abrasive windshield washer fluid to the washer reservoir.

The reservoir filler neck is located in the front of the engine compartment on the passenger side.

CAUTION

Washer pump

To prevent possible damage to the washer pump, do not operate the washer when the fluid reservoir is empty.

CAUTION

- To prevent possible damage to the wipers or windshield, do not operate the wipers when the windshield is dry.
- To prevent damage to the wiper blades, do not use gasoline, kerosene, paint thinner, or other solvents on or near them.
- To prevent damage to the wiper arms and other components, do not attempt to move the wipers manually.
- To prevent possible damage to the wipers and washer system, use anti-freezing washer fluids in winter or cold weather.

Heated washer nozzle (if equipped)

The heated washer nozzle function unfreezes the washer nozzles in freezing weather.

The heated washer nozzle will turn on and off automatically when the ignition switch or ENGINE START/STOP button is in ON position or when the engine is running in following conditions:

- Turns ON when the outside temperature is below 5 °C (41 °F), and OFF when it is over 10 °C (50 °F).
- The washer fluid unfreezing speed may be slower when the ignition switch or ENGINE START/STOP button is in ON position, than compared to when the engine is running.
- When the ignition switch or ENGINE START/STOP button is in ON position, after approximately 20 minutes of operation, the system will turn off automatically to prevent possible battery discharge.

- After the engine is running, the washer fluid will defrost approximately after 5 - 10 minutes.
- If the engine has been started within the operating temperature, the heated nozzle remains ON even approximately after 20 minutes.

* NOTICE

The heated washer nozzle may not function properly under following conditions:

- The washer fluid in the washer reservoir is frozen.
 - Outside temperature sensor is malfunctioning.
-

Welcome system (if equipped)

The welcome system is a function that illuminates the surroundings or the interior when the driver approaches or exits the vehicle.

Door handle lamp

When all the doors (and trunk) are closed and locked, the door handle lamp will illuminate for about 15 seconds if any of the following is performed.

- When the door unlock button is pressed on the smart key.
- When the button of the outside door handle is pressed.
- When you approach the vehicle with the smart key in possession.

Headlight (headlamp) escort function

The headlights (and/or taillights) remain on for approximately 5 minutes after the vehicle is turned off. However, if the driver's door is opened and closed, the headlights will turn off after 15 seconds.

The headlights can be turned off by pressing the lock button on the smart key twice or turning off the light switch from the headlight or Auto light position.

* NOTICE

If the driver exits the vehicle through another door besides the driver door, the battery saver function does not operate and the headlamp delay function does not turn OFF automatically. This may cause the battery to discharge. To avoid battery discharge, turn OFF the headlamps manually from the headlamp switch before exiting the vehicle.

Interior light

When the interior light switch is in the DOOR position and all doors (and trunk) are locked and closed, the room lamp will come on for 30 seconds if any of the following occurs:

- With the smart key system
 - When the door unlock button is pressed on the smart key.
 - When the button of the outside door handle is pressed.

At this time, if you press the door lock button, the lamps will turn off immediately.

Interior lights

This vehicle is equipped with lights throughout the vehicle to illuminate the interior.

* NOTICE

Do not use the interior lights for extended periods when the engine is not running.

It may cause battery discharge.

⚠ WARNING

Do not use the interior lights when driving in the dark. Accidents could happen because your view may be obscured by interior lights.

Automatic turn off function

The interior lights automatically turn off approximately 20 minutes after the ENGINE START/STOP button is turned off, if the lights are in the ON position.

If your vehicle is equipped with the theft alarm system, the interior lights automatically turn off approximately 5 seconds after the system is armed.

Map lamp



- Press the lens (1) to turn ON the map lamp.
To turn the map lamp OFF press the lens (1) again.
-  (2): DOOR mode
 - The map lamp and room lamp illuminate when a door is opened. The

lamps go out after approximately 30 seconds.

- The map lamp and room lamp come on for approximately 30 seconds when doors are unlocked with a smart key as long as the doors are not opened.²
- The map lamp and room lamp will stay on for approximately 10 minutes if a door is opened with the ENGINE START/STOP button in the ACC or OFF position.
- The map lamp and room lamp will stay on continuously if the door is opened with the ENGINE START/STOP button in the ON position.
- The map lamp and room lamp will turn off immediately if the ENGINE START/STOP button is changed to the ON position or all doors are locked.
- To turn off the DOOR mode, press the DOOR button (2) once again (not pressed).
-  (3): Press this switch to turn the front and rear room lamps on and off.

*** NOTICE**

The DOOR mode and ROOM mode can not be selected the same time.

Room lamp (if equipped)



Press the switch to turn the room lamp on and off.

Luggage room lamp



The luggage room lamp comes on when the trunk is opened.

⚠ CAUTION

The luggage room lamp comes on as long as the trunk opens. To prevent unnecessary charging system drain, close the trunk securely after using the luggage room.

Vanity mirror lamp

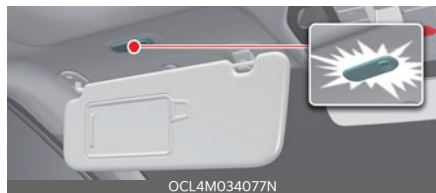

Push the switch to turn the light on or off.

⚠ CAUTION

Vanity mirror lamp

Always close the lid of the vanity mirror in the off position when the vanity mirror lamp is not in use. If the sun visor is closed without the lamp off, it may discharge the battery or damage the sun visor.

Climate control system



The climate control system uses cooling and heating to help maintain a pleasant environment inside the vehicle.

System operation

Ventilation

1. Set the mode to the  position.
2. Set the air intake control to the outside (fresh) air position.
3. Set the temperature control to the desired position.
4. Set the fan speed control to the desired speed.

Heating

1. Set the mode to the  position.
2. Set the air intake control to the outside (fresh) air position.
3. Set the temperature control to the desired position.
4. Set the fan speed control to the desired speed.
5. If dehumidified heating is desired, turn the air conditioning system on.
 - If the windshield fogs up, set the mode to the  or  position.

Operation tips

- To keep dust or unpleasant fumes from entering the vehicle through the ventilation system, temporarily set the air intake control to the recirculated air position. Be sure to return the control to the fresh air position when the irritation has passed to keep fresh air in the vehicle. This will help keep the driver alert and comfortable.
- Air for the heating/cooling system is drawn in through the grilles just at the base of the windshield. Care should be taken that it is not blocked by leaves, snow, ice or other obstructions.
- To prevent fog from forming on the inside of the windshield:
 - Set the air intake control to the fresh air position and the fan speed to the desired position.
 - Turn on the air conditioning system and adjust the temperature control to desired temperature.

Air conditioning (A/C)

All Kia air conditioning systems are filled with R-1234yf refrigerant.

1. Start the vehicle. Press the A/C button.
2. Set the mode to the  position.
3. Set the air intake control to the outside-air or recirculated air position.
4. Adjust the fan speed control and temperature control to maintain maximum comfort.

CAUTION

- The refrigerant system should only be serviced by trained and certified technicians to insure proper and safe operation.
- The refrigerant system should be serviced in a well-ventilated place.
- The air conditioning evaporator (cooling coil) shall never be repaired or replaced with one removed from a used or salvaged vehicle and new replacement Mobile Air conditioning (MAC) evaporators should be certi-

fied (and labeled) as meeting SAE Standard J2842.

CAUTION

Excessive air conditioning use

- When using the A/C system, monitor the temperature gauge closely while driving up hills or in heavy traffic when outside temperatures are high. Air conditioning system operation may cause engine overheating. Continue to use the blower fan but turn the air conditioning system off if the temperature gauge indicates engine overheating.
- When opening the windows in humid weather, air conditioning may create water droplets inside the vehicle. Since excessive water droplets may cause damage to electrical equipment, air conditioning should only be used with the windows closed.

CAUTION

The air conditioning system should only be used with the windows and sunroof closed to prevent condensation inside the vehicle that may cause damage to electrical components.

A/C system operation tips

- If the vehicle has been parked in direct sunlight during hot weather, open the windows for a short time to let the hot air inside the vehicle escape.
- To help reduce moisture inside the windows on rainy or humid days, decrease the humidity inside the vehicle by operating the A/C system.

- During A/C system operation, you may occasionally notice a slight change in vehicle speed as the air conditioning compressor cycles. This is a normal characteristic of system operation.
- To ensure maximum system performance, the A/C system should be run for a few minutes each month.
- When using the A/C system, you may notice clear water dripping (or even puddling) on the ground under the passenger side of the vehicle. This is a normal characteristic of system operation.
- Operating the A/C system in the recirculated air position provides maximum cooling. Continued operation in this mode may cause the air inside the vehicle to become stale.
- During cooling operation, you may occasionally notice a misty air flow because of rapid cooling and humid air intake. This is normal.

Climate control air filter

The climate control air filter removes dust and other pollutants that enter the vehicle from the outside. If dust or other pollutants accumulate in the filter over time, the airflow from the air vents may decrease. This leads to moisture accumulating on the inside of the windshield even when the fresh air intake mode is selected.

At this time, replace the the climate control filter. If you find it challenging to do so yourself, have the climate control filter replaced by an authorized Kia dealer. For details on how to replace the climate control air filter, refer to "Climate control air filter" on page 8-23.

⚠ CAUTION

Replace the climate control air filter according to the Maintenance Schedule. Failure to replace the climate control air filter on a regular basis can result in decreased airflow, diminished heating and cooling performance, and unpleasant odors.

*** NOTICE**

If the airflow from the air vents suddenly decreases, have your vehicle checked by an authorized Kia dealer.

Air conditioning refrigerant label (if equipped)

Example

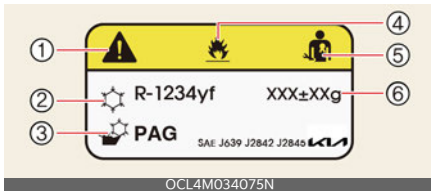

* The A/C refrigerant label in the vehicle may differ from the illustration.

Each symbol and specification on the A/C refrigerant label is represented below:

- 1 Caution
- 2 Classification of refrigerant
- 3 Classification of Compressor lubricant
- 4 Flammable Refrigerant
- 5 Requires a Registered Technician to service Air Conditioning system
- 6 Amount of refrigerant



The refrigerant label is located on the underside of the hood.

Checking the amount of air conditioner refrigerant and compressor lubricant

When the amount of refrigerant is low, the performance of the air conditioning is reduced. Overfilling also has a negative impact on the air conditioning system.

If abnormal operation is found, have the system inspected by an authorized Kia dealer.

⚠ WARNING

The oil and refrigerant in the A/C system are under very high pressure. If proper service procedures are not followed, an explosion may result. To reduce the risk of serious injury or death, the A/C system in your vehicle should only be serviced by trained and certified Kia technicians.

⚠ CAUTION

It is important that the correct type and amount of oil and refrigerant is used, otherwise damage to the vehicle may occur. To prevent damage, the air conditioning system in your vehicle should only be serviced by trained and certified technicians.

⚠ WARNING**Vehicles equipped with R-1234yf**

Since the refrigerant is mildly flammable and operated at high pressure, the air conditioning system should only be serviced by trained and certified technicians. (Refer to the SAE J2845)

It is important that the correct type and amount of oil and refrigerant are used.

All refrigerants should be reclaimed with proper equipment. Venting refrigerants directly to the atmosphere is harmful to individuals and environment.

Failure to heed these warnings can lead to serious injuries.

Manual climate control system (if equipped)

The manual climate control system uses cooling and heating to help maintain a pleasant environment inside the vehicle.

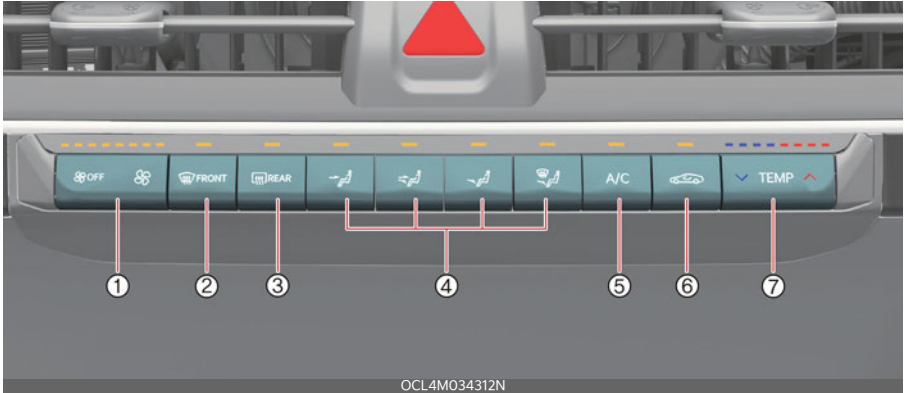



- 1 Fan speed control/off button
- 2 Front windshield defroster button
- 3 Rear window defroster button
- 4 Mode selection button
- 5 A/C button
- 6 Air intake control button
- 7 Temperature control button

CAUTION

Operating the blower when ignition switch or ENGINE START/STOP button is in the ON position could cause the battery to discharge. Operate the blower when the engine is running.

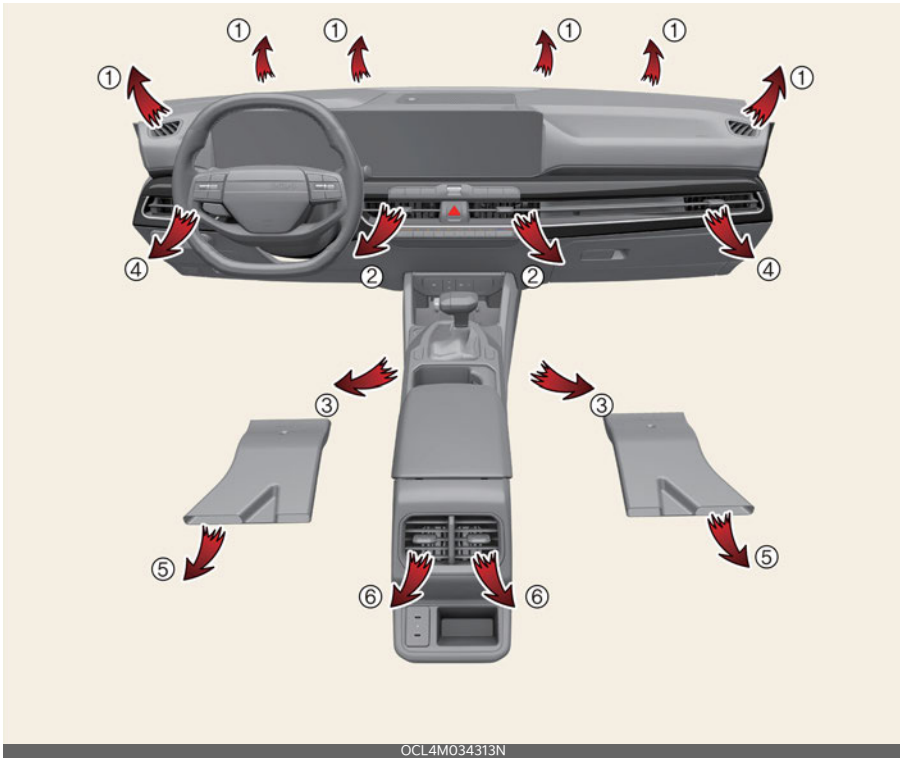
Heating and air conditioning



1. Start the engine.
2. Set the mode to the desired position.
To improve the effectiveness of heating and cooling;
 - Heating: 
 - Cooling: 
3. Set the temperature control to the desired position.
4. Set the air intake control to the outside (fresh) air position.
5. Set the fan speed control to the desired speed.
If air conditioning is desired, turn the air conditioning system on.

Mode selection

The mode selection buttons control the direction of the air flow through the ventilation system.



Air can be directed to the floor, dashboard outlets, or windshield. Five symbols are used to represent Face, Bi-Level, Floor, Floor-Defrost and Defrost air position.

Face-Level (2, 4, 6)

Air flow is directed toward the upper body and face. Additionally, each outlet can be controlled to direct the air discharged from the outlet.

Bi-Level (2, 3, 4, 5, 6)

Air flow is directed towards the face and the floor.

Floor-Level (1, 3, 4, 5)

Most of the air flow is directed to the floor, with a small amount of the air being directed to the windshield, side window defrosters and side air vents.

Floor/Defrost-Level (1, 3, 4, 5)

Most of the air flow is directed to the floor and the windshield with a small amount directed to the side window defrosters and side air vents.

Defrost-Level (1, 4)

Most of the air flow is directed to the windshield with a small amount of air directed to the side window defrosters and side air vents.

Controlling the opening/closing and directions of the vents

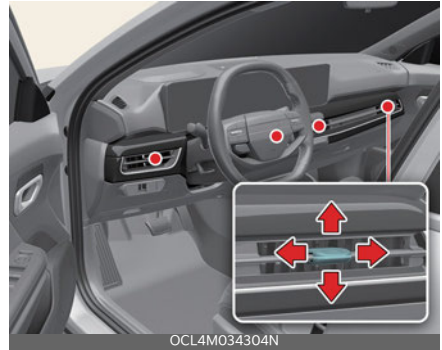

Center (if equipped)



You can adjust the direction of air delivered from these vents using the vent control lever as shown.

Temperature control

The temperature control button allows you to control the temperature of the air flowing from the ventilation system.

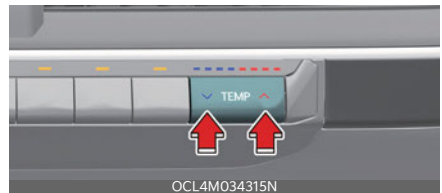

To change the air temperature, push the button right to warm and hot air, or left to cooler air.

*** NOTICE**

When starting the vehicle in cold weather using manual temperature control, operate the system in the following method to improve heating:

- Turn off or lower the blower right after starting the engine.
- Allow the engine to warm up since the air flow from the heater is still cold.
- After a few minutes of engine warm up, turn on or set the fan to a higher level and adjust the temperature setting to hot.

Controlling air intake

The air intake control is used to select the outside (fresh) air position or recirculated air position.



To change the air intake control position.

- Push the desired control button

Recirculated air position



The indicator light on the button appears when the recirculated air position is selected.

With the recirculated air position selected, air from the passenger compartment will be drawn through the heating system and heated or cooled according to the function selected.

Outside (fresh) air position



The indicator light on the button will turn off when the outside (fresh) air position is selected.

With the outside (fresh) air position selected, air enters the vehicle from outside and is heated or cooled according to the function selected.

*** NOTICE**

Prolonged operation of the heater in the recirculated air position (without air conditioning selected) may cause fogging of the windshield and side windows and make the air in the passenger compartment stale.

Prolonged use of the air conditioning with the re-circulated air position selected will result in excessively dry air in the passenger compartment.

⚠ WARNING

- Continued climate control system in the recirculated air position may allow humidity to increase inside the vehicle which may fog the glass and obscure visibility.
- Do not sleep in a vehicle with the air conditioning or heating system on. It may cause serious harm or death due to a drop in the oxygen level and/or body temperature.
- Continued climate control system in the recirculated air position can cause drowsiness or sleepiness, and loss of vehicle control. Set the air intake control to the outside (fresh) while driving.

Controlling fan speed

The fan speed control button allows you to control the fan speed of the air flowing from the ventilation system.

The ignition switch or ENGINE START/STOP button must be in the ON position for fan operation.

To change the fan speed:

- Push the button right to higher speed, or left to lower speed.

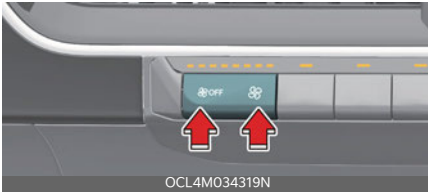

To turn off the blowers:

- Press down left side of the fan speed control button several times or keep pressing it down.

Air conditioning (A/C)



- Press the A/C button to turn the air conditioning system on (indicator light will appear).
- Press the button again to turn the air conditioning system off.

Automatic climate control system

Climate control display

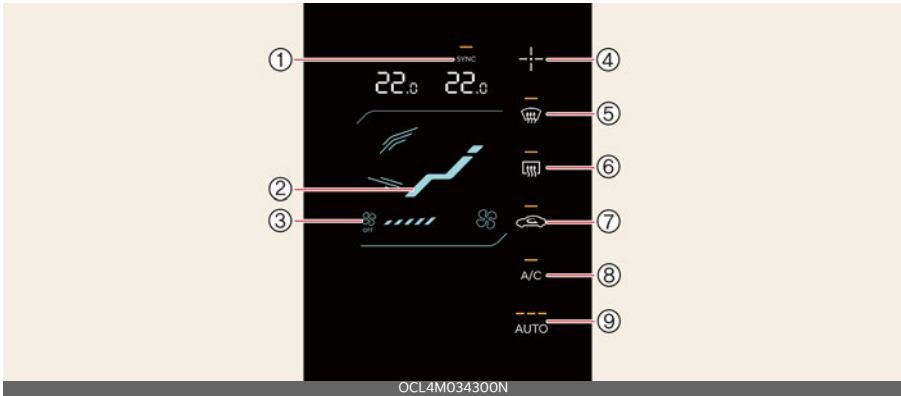

Instrument panel



- 1** SYNC button
 - Press the SYNC button to adjust the driver and passenger side temperature to the same value.
- 2** Mode selection button
- 3** Fan speed control/off button
- 4** Infotainment system screen on/off button
- 5** Front-windshield defroster button
- 6** Rear-window defroster button
- 7** Air intake control button
- 8** Air conditioning A/C button
- 9** AUTO (automatic control) button
- 10** Driver's side temperature control lever
- 11** Fan speed control/off lever
- 12** Mode selection lever
- 13** Passenger's side temperature control lever

Heating and air conditioning manually

The heating and cooling system can be controlled manually by pressing buttons or pulling the lever other than the AUTO button.

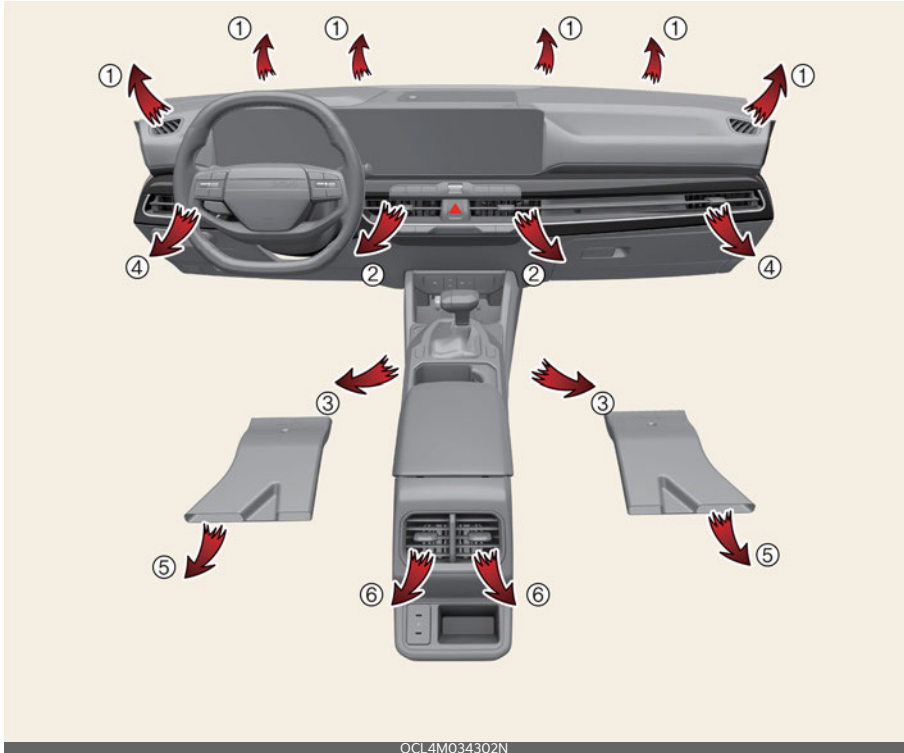





OCL4M034302N

The system works sequentially according to the order of buttons or levers selected.

- 1 Start the vehicle.
- 2 Set the mode-selection buttons as desired. To improve the effectiveness of heating and cooling:
 - Heating: (🔥)
 - Cooling: (❄️)
- 3 Set the temperature control to the desired temperature level.
- 4 Set the air intake control to the position for outside (fresh) air if required.
- 5 Set the position of the fan speed control so that it operates at the desired speed.
- 6 If desired, turn the air conditioning on with the temperature set high in order to dehumidify the air before it enters the cabin.

If the windshield fogs up, select the Front Defrost (🌬️) mode.

Press the AUTO button in order to convert to full automatic control of the system.

Mode	Operation	Air flow Front seats
	Air flow is directed toward the upper body and face.	2,4, 6
	Air flow is directed towards the face and the floor.	2, 3, 4, 5, 6
	Most of the air flow is directed to the floor, with a small amount of air directed to the windshield, side-window defrosters, and side air vents.	1, 3, 4, 5
	Most of the air flow is directed to the floor and the windshield, with a small amount directed to the side-window defrosters and side air vents.	1, 3, 4, 5
	Most of the air flow is directed to the windshield, with a small amount of air directed to the side-window defrosters and side air vents.	1, 4

Mode select

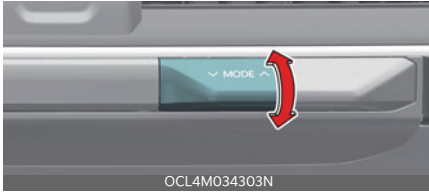

Select the direction of the air flow through the ventilation system. The air flow outlet ports are enabled in the following sequence:



Controlling the opening/closing and directions of the vents

For front seats

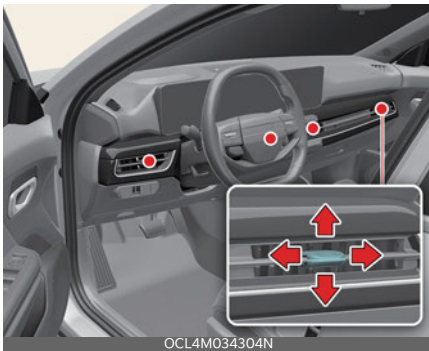

Center (if equipped)

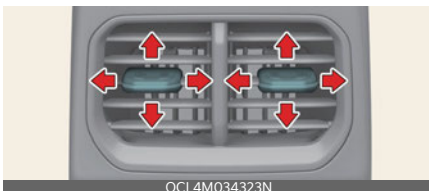

You can adjust the direction of air delivered from these vents using the vent control lever as shown. If you do not want the air delivered, place the vent control lever to the close position (⊗).

Air conditioning A/C

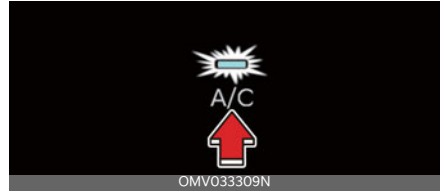

- Press the A/C button.

* NOTICE

- If you operate the air conditioner excessively in the summer, moisture may accumulate on the windows outside the vehicle due to the temperature difference between the inside and outside of the vehicle. In this case, change the air flow to this location (↙) and set the fan speed control to low.
- When the air conditioner is turned on in an area with high humidity, it is natural for dew to form on the outside of the vehicle. This has nothing to do with vehicle performance.

Controlling the air intake

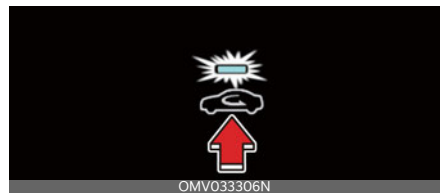

- Select the outside (fresh) air position or recirculated air position.
- Outside (fresh) air position: Air enters the vehicle from outside. The indicator light will turn off.

Controlling heating and air conditioning automatically



1. Set the desired temperature.
2. Press the AUTO button to control:
 - Mode
 - Fan speed
 - Air intake
 - Air conditioning

Level	Indicator	Climate control display	Air flow
High			2~8
Medium			1~7
Low			1~4

- Set the temperature with the temperature control button.

Controlling the temperature



- Pull the temperature control lever up or down.

Adjusting the driver and passenger side temperature to the same value

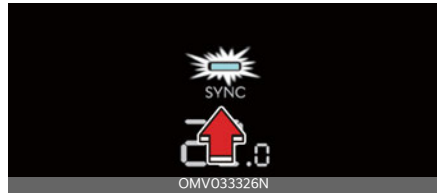

1. Press the SYNC button.
2. When the SYNC button indicator illuminates, the temperature controls do not operate independently.

Controlling fan speed automatic climate control system controlling fan speed

Climate control display



Instrument panel



- Climate control display: Press the left or right button to adjust the speed.
- Instrument panel: Press the lever up or down.

WARNING

Reduced Visibility

Continuous use of the climate control system in the recirculated air position

may allow humidity to increase inside the vehicle, which may fog the glass and obscure visibility.

▲ WARNING

Recirculated Air

Continued use of the climate control system in the recirculated air position can cause drowsiness or sleepiness, and loss of vehicle control. Set the air intake control to the outside (fresh) air position as much as possible while driving.

▲ WARNING

Sleeping with A/C on

Do not sleep in a vehicle with the air conditioning or heating on, as this may cause serious harm or death due to a drop in oxygen level and/or body temperature.

*** NOTICE**

- Operating the blower when the ENGINE START/STOP button is in the ON position could cause the battery to drain. Operate the blower when the engine is running.
- Prolonged operation of the heater in the recirculated air position (without air conditioning selected) may cause fogging of the windshield and side windows and make the air in the passenger compartment stale. In addition, prolonged use of the air conditioning in the re-circulated air position will result in excessively dry air in the passenger compartment.
- To turn the automatic operation off, select any button or lever of the following:
 - Mode selection button/lever

- Air conditioning button
- Front-windshield defroster button (Press the button one more time to deselect the front windshield defroster function. The AUTO sign will illuminate on the information display once again.)

- Fan speed control button/lever

The selected function will be controlled manually while other functions operate automatically.

- To improve the effectiveness of the climate control, use the AUTO button and set the temperature to 22 °C (72 °F).
- Never place anything over the sensor located on the instrument panel to increase control of the heating and cooling system.
- To help improve microphone voice input sound, fan speed may automatically slow down for a couple of minutes when you activate voice recognition or hands free.

Turning off the climate control system

Climate control display

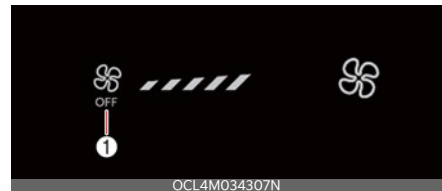

Instrument panel



- Climate control display: Touch the button (1) several times or keep pressing it.
- Instrument panel: Press down the fan speed control lever (2) several times or keep pressing it down.

Automatic air ventilation

When operating heater and air conditioner for the vehicle ventilation, if you maintain the Recirculation mode for 30 minutes or at low temperatures, it automatically changes to Fresh mode.

Operation

Select **Setup** → **Vehicle** → **Climate** → **Automatic Ventilation** → **Automatic Dehumidify** to activate or deactivate from the Settings menu in the Infotainment System screen.

* INFORMATION

The infotainment system may change after software updates. For more information, refer to the user's manual provided in the infotainment system and the quick reference guide.

Recirculate Air (if equipped)

This function automatically switches the air conditioning system to internal air circulation mode based on the navigation map information and the speed of the vehicle to prevent polluted air from

entering the cabin when passing through a tunnel or an area with a smell.

Operation

- Select **Setup** → **Vehicle** → **Climate** → **Recirculate Air** on the Infotainment System screen.
 - **Activate upon Washer Fluid Use:** Washer fluid odor is automatically prevented from entering the cabin.
 - **Activate upon Entering Tunnels:** Automatic closing of windows and activation of internal air circulation upon entering a tunnel.

Operating condition(s)

- When driving on a highway (or motorway)
- When the air conditioning system is in fresh air intake mode

⚠ CAUTION

Be careful not to get any part of your body caught when the windows are closing.

Recirculating air when washer fluid is used (if equipped)

Recirculation mode automatically activates to reduce any odor of the washer fluid from entering the cabin when the windshield washer is used.

Operation

- Recirculating air when washer fluid is used is activated when you select **Setup** → **Vehicle** → **Climate** → **Climate Features** → **Activate upon Washer Fluid Use** from the Settings menu in the Infotainment System screen.

- Pull the wiper lever toward you. A message will be displayed on the infotainment system.

Operating condition(s)

- When the vehicle is in on position

* NOTICE

When the temperature outside is low, moisture may accumulate on the windows. In this case, press the front-windshield defroster button to remove it.

Air conditioning

All Kia A/C systems are filled with R-1234yf refrigerant.

1. Start the vehicle. Press the air conditioning button.
2. Set the mode to the (↔) position.
3. Set the air intake control to the outside-air or recirculated air position.
4. Adjust the fan speed control and temperature control to maintain maximum comfort.
 - When maximum cooling is desired, set the temperature control to the extreme low position, then set the fan speed control to the highest speed.

⚠ CAUTION

- The refrigerant system should only be serviced by trained and certified technicians to insure proper and safe operation.
- The refrigerant system should be serviced in a well-ventilated place.
- The air conditioning evaporator (cooling coil) shall never be repaired or replaced with one removed from a used or salvaged vehicle and new replacement Mobile Air Conditioning

(MAC) evaporators should be certified (and labeled) as meeting SAE Standard J2842.

⚠ CAUTION

- When using the A/C system, monitor the temperature gauge closely while driving up hills or in heavy traffic when outside temperatures are high. A/C system operation may cause vehicle overheating. Continue to use the blower fan but turn the A/C system off if the temperature gauge indicates vehicle overheating.
- When opening the windows in humid weather, A/C may create water droplets inside the vehicle. Since excessive water droplets may cause damage to electrical equipment, air conditioning should only be used with the windows closed.

A/C operation tips

- If your vehicle has been parked in direct sunlight during hot weather, open the windows for a short time to let the hot air inside the vehicle escape.
- To help reduce moisture inside of the windows on rainy or humid days, decrease the humidity inside the vehicle by operating the air conditioning system.
- During A/C system operation, you may occasionally notice a slight change in vehicle speed as the air conditioning compressor cycles. This is a normal system operation characteristic.
- Use the air conditioning system at least every month for a few minutes

to ensure maximum system performance.



- When using the A/C system, you may notice clear water dripping (or even puddling) on the ground under the passenger side of the vehicle. This is a normal system operation characteristic.
- Operating the A/C system in the recirculated air position provides maximum cooling; however, continual operation in this mode may cause the air inside the vehicle to become stale.
- During cooling operation, you may occasionally notice a misty air flow because of rapid cooling and humid air intake. This is a normal system operation characteristic.

Windshield defrosting and defogging

When the windshield is covered with frost or moisture, the front view is blurred, you should remove the frost and moisture.

WARNING

Windshield heating

Do not use the  or  position during cooling operation in extremely humid weather. The difference between the temperature of the outside air and the windshield could cause the outer surface of the windshield to fog up, causing loss of visibility. In this case, set the mode selection to the  position and fan speed control to the lower speed.

- For maximum defrosting, set the temperature control to the extreme right/hot position and the fan speed control to the highest speed.
- If warm air to the floor is desired while defrosting or defogging, set the mode to the floor-defrost position.
- Before driving, clear all snow and ice from the windshield, rear window, outside rearview mirrors, and all side windows.
- Clear all snow and ice from the hood and air inlet in the cowl grill to improve heater and defroster efficiency and to reduce the probability of fogging up the inside of the windshield.

CAUTION

Do not place anything on the instrument panel which may cover the air outlets. Otherwise, air flow may be obstructed,

preventing the windshield defoggers from defogging.

Defogging Inside Windshield with manual climate control system

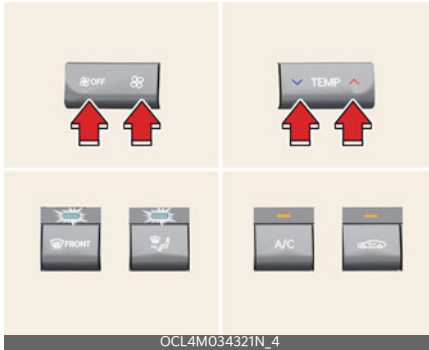

1. Select any fan speed except off position.
 2. Select desired temperature.
 3. Select the or position.
 4. The outside (fresh) air and air conditioning will be selected automatically.
- If the air conditioning and outside (fresh) air position are not selected automatically, press the corresponding button manually.

Defrosting Outside Windshield with manual climate control system

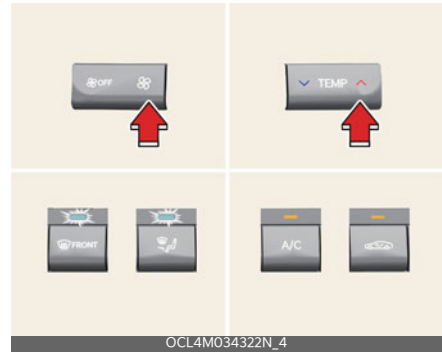

1. Set the fan speed to the highest (extreme right) position.
2. Set the temperature to the extreme hot position.
3. Select the position.
4. The outside (fresh) air and air conditioning will be selected automatically.

Defogging inside windshield with automatic climate control

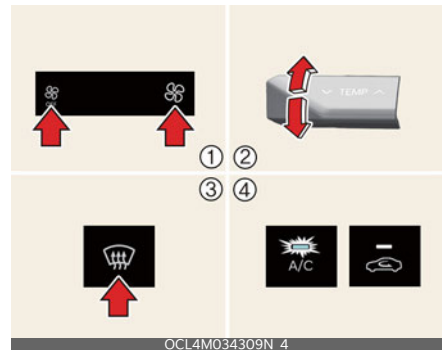

1. Set the fan speed to the desired position.
2. Select desired temperature.
3. Press the defroster button .

4. The outside (fresh) air position will be selected automatically and the air conditioning will turn on according to the detected ambient temperature. If the air conditioning and outside (fresh) air position are not selected automatically, adjust the corresponding button manually. If the  position is selected, lower fan speed is adjusted to a higher fan speed.

Defrosting outside windshield with automatic climate control

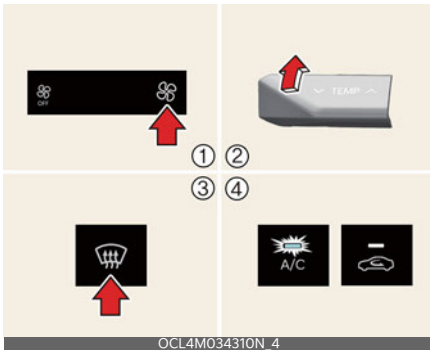

1. Set the fan speed to the highest position.
2. Set the temperature to the extreme hot (HI) position.
3. Press the defroster button .
4. The outside (fresh) air position will be selected automatically and the air conditioning will turn on according to the detected ambient temperature.

Auto defogging system (if equipped)

Auto defogging helps reduce the possibility of fogging up the inside of the windshield by automatically sensing the moisture on inside the windshield.



 The auto defogging system operates when the heater or air conditioning is on.

When the Auto Defogging System operates, the indicator will appear. If a high amount of humidity is detected in the vehicle, the Auto Defogging System will be enabled.

The following steps will be performed automatically:

1. The A/C button will turn ON.
2. The air intake control will change to Fresh mode under low outside temperature.
3. The mode will be changed to defrost to direct airflow to the windshield.
4. The fan speed will be increased.

To cancel or reset the Auto Defogging System

Press the front windshield defroster button for 3 seconds when the ignition switch or ENGINE START/STOP button is in the ON position.

When the Auto Defogging System is canceled, defrost button indicator will blink 3 times.

When the Auto Defogging System is reset, defrost button indicator will blink 6 times without a signal.

* NOTICE

- When the air conditioning is turned on by Auto defogging system, if you try to turn off the air conditioning, the indicator will blink 3 times and the air conditioning will not be turned off.
- To maintain the effectiveness and efficiency of the Auto Defogging System, do not select Recirculation mode while the system is operating.
- When the Auto Defogging System is operating, the fan speed adjustment knob, the temperature adjustment knob, and the air intake control button are all disabled.

* NOTICE

Do not remove the sensor cover located on the upper end of the driver side windshield glass.

Damage to system parts could occur and may not be covered by your vehicle warranty.

Defroster

The vehicle is equipped with a defroster for removing frost or fog from the rear window.

⚠ CAUTION

Conductors

To prevent damage to the conductors bonded to the inside surface of the rear window, never use sharp instruments or window cleaners containing abrasives to clean the window.

If you want to defrost and defog the front windshield, refer to "Windshield defrosting and defogging" on page 4-110.

Operating rear window defroster

The defroster heats the window to remove frost, fog and thin ice from the rear window, while the engine is on.

If there is heavy accumulation of snow on the rear window, brush it off before operating the rear defroster.



To activate the rear window defroster:

- Press the rear window defroster button located in the climate control display.

The indicator on the rear window defroster button illuminates when the defroster is ON.

The rear window defroster automatically turns off after approximately 20 minutes or when the ignition switch or ENGINE START/STOP button is turned off.



To turn off the defroster:

- Press the rear window defroster button again.

Outside mirror defroster

If your vehicle is equipped with the outside mirror defrosters, they will operate at the same time you turn on the rear window defroster.

Defogging logic (if equipped)

To reduce the possibility of fogging up the inside of the windshield, the air intake or air conditioning is controlled automatically according to certain conditions such as  or  position.

To cancel automatic defogging logic or return to the automatic defogging logic, do the following.

Canceling/returning automatic defogging logic

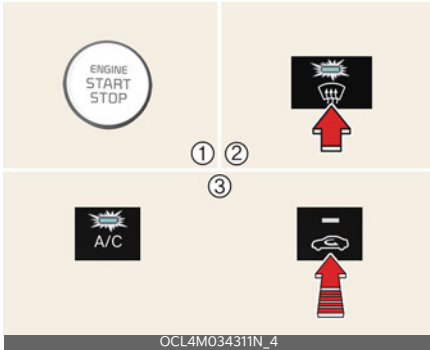

1. Turn the ignition switch or ENGINE START/STOP button to the ON position.
2. Press the defroster button .
3. While pressing the air conditioning (A/C) button, press the air intake control button at least 5 times within 3 seconds.

The recirculation indicator blinks 3 times in 0.5 second of intervals. It indicates that the defogging logic is canceled or returned to the programmed status.

If the battery has been discharged or disconnected, it resets to the defogging logic status.

When starting the vehicle in cold weather using manual temperature control, operate the system in the following method to improve heating.

- Turn off or lower the blower, right after starting the engine.

- Allow the engine to warm up during this time since the air flow from the heater is still cold.
- After a few minutes of engine warm up, turn on or set the fan to a higher level and adjust the temperature setting to hot.

A/C Automatic Drying

A/C Automatic Drying feature dries the moisture in the air conditioner and reduces air conditioner odor. The blower motor automatically operates after 30 minutes the vehicle is turned off.

Turning A/C Automatic Drying on or off

The A/C Automatic Drying feature can be turned on and off by selecting **Setup** → **Vehicle** → **Climate** → **Climate Features** → **A/C Automatic Drying** from the infotainment system. See additional information in supplied infotainment manual.

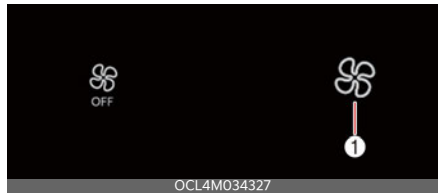

If the operating condition is satisfied, a symbol (1) will be displayed on the climate control display (only for automatic control) and then the blower motor will automatically operate on schedule. The symbol will be blinking.

When the A/C Automatic Drying feature is activated, the air conditioner sets the fan speed to the third level, selects Fresh mode, and directs the air flow to the vent.

Operating conditions

The A/C Automatic Drying feature operates under the following conditions:

- The vehicle is turned off after operating the air conditioner for a certain period
- The 12-volt battery level is sufficient
- The outside temperature is above a certain level

Non-operating conditions

The A/C Automatic Drying feature stops operating under the following conditions:

- The A/C Automatic Drying feature has operated for 10 minutes
- The ignition switch or ENGINE START/STOP button is pressed, or the vehicle is ON
- The climate control system is operated remotely

* NOTICE

- The A/C Automatic Drying feature reduces air conditioner odors but may not remove all odors.
- The A/C Automatic Drying feature does not operate if the remaining battery level is insufficient to prevent battery discharge.

* INFORMATION

The infotainment system may change after software updates. For more information, refer to the user's manual provided in the infotainment system and the quick reference guide.

Storage compartment

These compartments can be used to store small items required by the driver or passengers.

- To avoid possible theft, do not leave valuables in the storage compartment.
- Always keep the storage compartment covers closed while driving. Do not attempt to place so many items in the storage compartment that the storage compartment cover cannot close securely.

⚠ WARNING

Flammable materials

Do not store glasses, gas lighter, portable battery, canned beverage, spray can, propane cylinder, cosmetic tube or other flammable/explosive materials in the vehicle. These items may catch fire and/or explode if the vehicle is exposed to hot temperatures for extended periods.

Center console storage



To open the center console storage:

- Pull up the lever.

Glove box



To open the glove box:

- Pull the handle and the glove box will automatically open.

Close the glove box after use.

⚠ WARNING

Glove Box

To reduce the risk of injury in an accident or sudden stop, always keep the glove box door closed while driving.

⚠ CAUTION

Do not keep food in the glove box for a long time.

*** NOTICE**

If the temperature control switch is in the warm or hot position, warm or hot air will flow into the glove box.

Luggage net holder (if equipped)

To keep items from shifting in the cargo area, you can use the 4 holders located in the cargo area to attach the luggage net (sold separately).

⚠ CAUTION

To prevent damage to the goods or the vehicle, be careful when carrying fragile or bulky objects in the luggage compartment.

⚠ WARNING

DO NOT over-stretch the luggage net and ALWAYS keep your face and body out of the luggage net's recoil path. Failure to comply with these instructions may result in severe facial injuries. DO NOT use the luggage net when the strap has visible signs of wear or damage.

Interior features

There are various features inside the vehicle for the convenience of the occupants.

Cup holder

Front



Rear (if equipped)



Cups or small beverage cans may be placed in the cup holders.

⚠ WARNING

Hot liquids

Do not place uncovered cups with hot liquid in the cup holder while the vehicle is in motion. If the hot liquid spills, you could be burned. A burn to the driver could lead to loss of control of the vehicle.

⚠ WARNING

Keep cans or bottles out of direct sunlight and do not put them in a vehicle that is hot. They could explode.

⚠ CAUTION

- Keep your drinks sealed while driving to prevent spillage. If liquid spills, it

may get into the vehicle's electrical/ electronic system and damage electrical/electronic parts.

- When cleaning spilled liquids, do not use heat to dry the cup holders. This may damage the cup holder.

Seat warmer (if equipped)

The seat warmer is provided to warm the front and rear seats during cold weather.

Front seat



Rear seat



With the ignition switch or ENGINE START/STOP button in the ON position:

- Push either of the button to warm the seats.

During mild weather or under conditions where the operation of the seat warmer is not needed, keep the button in the off position.

The seat warmer defaults to the off position whenever the ignition switch or ENGINE START/STOP is turned on.

Temperature control (Manual)

- Each time you press the button, the temperature setting of the seat will change as follows:
 - Front seat

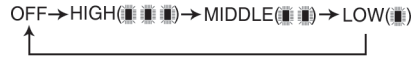

- Rear seat



Temperature control (Automatic)

The seat warmer starts to automatically control the seat temperature in order to prevent low-temperature burns after being manually turned ON.

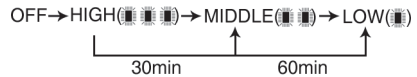

You may manually press the button to increase the seat temperature. However, it soon returns to the automatic mode again.

- When pressing the button for more than 1.5 seconds with the seat warmer operating, the seat warmer will turn OFF.

* NOTICE

When the seat warmer button are in the ON position, the heating system in the seat turns off or on automatically depending on the seat temperature.

⚠ CAUTION

- When cleaning the seats, do not use an organic solvent such as paint thinner, benzene, alcohol or gasoline.

Doing so may damage the surface of the warmer or seats.

- To prevent overheating the seat warmer, do not place anything on the seats that insulates against heat, such as blankets, cushions or seat covers while the seat warmer is in operation.
- Do not place heavy or sharp objects on seats equipped with seat warmers. Damage to the seat warming components could occur.
- Do not change the seat cover. It may damage the seat warmer or air ventilation system.

⚠ WARNING

Seat warmer burns

Passengers should use extreme caution when using seat warmers due to the possibility of excess heating or burns. The seat warmer may cause burns even at low temperatures, especially if used for long periods of time. In particular, the driver must exercise extreme care for the following types of passengers:

1. Infants, children, elderly, disabled persons, or hospital outpatients
2. Persons with sensitive skin or those that burn easily
3. Fatigued individuals
4. Intoxicated individuals
5. Individuals taking medication that can cause drowsiness or sleepiness (sleeping pills, cold tablets, etc.)

Air ventilation seat (if equipped)

Front seat



The temperature setting of the seat changes according to the buttons position.

- To ventilate your seat cushion, push the buttons.

Each time you push the buttons, the airflow will change as follows:

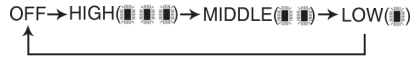

When pressing the button for more than 1.5 seconds with the seat ventilation operating, the seat ventilation system will turn OFF.

The air ventilation seat defaults to the off position whenever the ignition switch or ENGINE START/STOP button is turned ON.

⚠ CAUTION

Seat damage

- When cleaning the seats, do not use an organic solvent such as paint thinner, benzene, alcohol and gasoline. Doing so may damage the air ventilation seat.
- Do not place heavy or sharp objects on the seat. Those things may damage the air ventilation seat.
- Be careful not to spill liquid such as water or beverages on the seat. If you spill some liquid, wipe the seat with a

dry towel. Before using the air ventilation seat, dry the seat completely.

Sun visor

Use the sun visor to shield direct light through the front or side windows.



- To use the sun visor, pull it downward.
 - To use the sun visor for the side window, pull it downward, unsnap it from the bracket (1) and swing it to the side (2). You can slide the sun visor if necessary (3, if equipped).
 - To use the vanity mirror, pull down the visor and slide the mirror cover (4).
- The ticket holder (5, if equipped) is provided for holding a tollgate ticket.

WARNING

Do not block your view when using the sun visor.

NOTICE

Do not put several tickets in the ticket holder at the same time. This could cause damage to the ticket holder.

USB charger

The USB car charger allows drivers to charge their digital devices such as smartphones, and PC tablets.

Front



Rear



Plug the cable into the USB port, and charging will begin.

The USB car charger is available with either the ACC or the ignition on. Connect the USB port and digital devices while the engine is running. Check the display screen of the device to check its charging process completion. Your smartphone or tablet PC could be heated up while charging. This will not impact life or functions of the device. For safety, charging can be stopped if the battery heats up to a high temperature that could affect the device. Charging some digital devices may require dedicated adapters if their charging methods don't comport with the USB charging port. Power Delivery 3.0 is available on a smartphone or the tablet equipped with fast charging capabilities.

The smartphone or tablet without fast charging will be charged at regular speed.

- Rated output: 9.0 V/Max 3.0 A

⚠ CAUTION

- Use the USB car charger with the ignition on. Otherwise, Vehicle battery can be discharged.
- Use the official USB cable of the manufacturer of the digital device to be charged.
- Make sure that any foreign object or liquid does not contact the USB car charger. Water or foreign object can damage the USB charger.
- Do not use the device whose current consumption exceeds 3.0 A.
- If the charger is connected incorrectly, it can cause serious damage to the devices. Please note that damages due to incorrect usage are not covered by warranty service.
- Do not connect an electrical device that generates excessive electromagnetic noise to the USB car port. If you do so, noise can be heard or vehicle electronic devices can be interrupted while audio or AV is on.

Power outlet

The power outlet is designed to provide power for mobile telephones or other devices designed to operate with vehicle electrical systems.

Front



The devices should draw less than 15 amps with the vehicle on.

*** NOTICE**

- Use the power outlet only when the vehicle is on and remove the accessory plug after use. Using the accessory plug for prolonged periods of time with the vehicle off could cause the battery to discharge.
- Only use 12 V electric accessories which are less than 15 A in electric capacity.
- Adjust the air-conditioner or heater to the lowest operating level when using the power outlet.
- Close the cover when not in use.
- Some electronic devices can cause electronic interference when plugged into a vehicle's power outlet. These devices may cause excessive audio static and malfunctions in other electronic systems or devices used in your vehicle.
- Push the plug in as far as it will go. If good contact is not made, the plug may overheat and the fuse may open.
- Plug in battery equipped electronic devices with reverse current protection. The current from the battery may flow into the vehicle's electrical/electronic system and cause system malfunction.
- When using a smartphone application (such as Android Auto) while charging, charging may be delayed or stopped. This is not a problem with the wireless charging system but is caused by the smartphone overheating. Please remove the smartphone from the charging pad.

⚠ WARNING**Electric shock**

Do not put a finger or a foreign object (pen, etc.) into a power outlet and do not touch with a wet hand. You may get an electric shock.

⚠ CAUTION

Do not connect another vehicle's Tire Mobility Kit (TMK) to the power outlet or battery terminal. The unmatched power requirement between the vehicle power outlet and the tire mobility kit can cause fire or circuit damage within the vehicle and the Tire Mobility Kit.

Wireless smartphone charging system (if equipped)

On certain models, the vehicle comes equipped with a wireless smart phone charger.

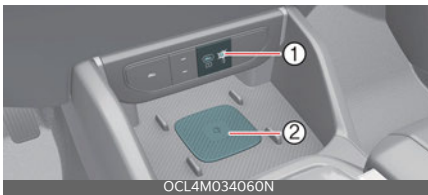

1 Indicator

2 Charging pad

The wireless smart phone charging system charges only the Qi-enabled smart phones (Qi).

Read the label on the smart phone accessory cover or visit your smart phone manufacturer's website to check whether your smart phone supports the Qi technology.

The wireless charging process starts when you put a Qi-enabled smart phone on the wireless charging unit.

1. Remove other items, including the smart key, from the wireless charging unit. If not, the wireless charging process may be interrupted. Place the smart phone on the center of the charging pad.
2. The system is available when all doors are closed, and when the START/STOP button is in the ON or START position.
3. You can turn ON or OFF the wireless charging function from the Settings menu in the infotainment system screen. Select **Setup** → **Vehicle** → **Convenience** → **Wireless Charging System for Mobile Devices**.
4. The indicator light is orange when the smart phone is charging. The indicator light will turn Green when phone charging is complete.
 - The indicator light will blink orange for 10 seconds if there is a malfunction in the wireless charging system.
 - The system warns you with a message on the LCD display if the smart phone is still on the wireless charging unit after the vehicle is turned OFF and the front door is opened.
 - For some manufacturer's smart phones, the system may not warn you even though the smart phone is left on the wireless charging unit. This is due to the particular characteristic of the smart phone and not a malfunction of the wireless charging.
 - When charging certain smart phones, the charging indicator may not change to green when the smart phone is fully charged.
 - When any smart phone without a wireless charging function or a metallic object is placed on the charging pad, a small noise may sound. This

small sound is due to the vehicle discerning compatibility of the object placed on the charging pad. It does not affect your vehicle or the smart phone in any way.

⚠ WARNING

If any metallic object such as coins is located between the wireless charging system and the smart phone, the charging may be disrupted. Also, the metallic object may heat up.

*** NOTICE**

- When placing your smart phone on the charging pad, position the phone in the middle of the mat for optimal charging performance. If your smart phone is off to the side, the charging rate may be less and in some cases the smart phone may experience higher heat conduction.
- When charging some smart phones with a self-protection feature, the wireless charging speed may decrease and the wireless charging may stop.
- The wireless charging process may temporarily stop, when temperature abnormally increases inside the wireless smart phone charging system. The wireless charging process restarts, when temperature falls to a certain level.
- The wireless smart phone charging system may not support certain smart phones, which are not verified for the Qi specification (Qi).
- In some cases, the wireless charging may stop temporarily when the smart key is used, either when starting the vehicle or locking/unlocking the doors, etc.

- If the smart phone has a thick cover, the wireless charging may not be possible.
- If the smart phone is not completely contacting the charging pad, wireless charging may not operate properly.
- Some magnetic items like credit cards, phone cards or rail tickets may be damaged if left with the smart phone during the charging process.
- During wireless charging, an internal fan operates to prevent overheating. Fan noise may sound.

This device complies with Industry Canada licence-exempt RSS standard(s).

Operation is subject to the following two conditions:

1. This device may not cause interference, and
2. This device must accept any interference, including interference that may cause undesired operation of the device.

Coat hook

A Coat hook is next to the rear grab handle.



* This actual feature may differ from the illustration.

⚠ CAUTION**Hanging clothing**

Do not hang heavy clothes, since they may damage the hook.

⚠ WARNING

Do not hang other objects such as hangers or hard objects except clothes. Also, do not put heavy, sharp or breakable objects in the clothing's pockets. In an accident or when the curtain airbag is inflated, it may cause vehicle damage or body injury.

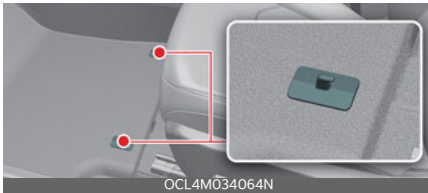
**Floor mat anchor(s) (if equipped)**

When using a floor mat on the front floor carpet, make sure it attaches to the floor mat anchor(s) in your vehicle. This keeps the floor mat from sliding forward.

⚠ WARNING**After market floor mat**

- Do not install aftermarket floor mats that are not capable of being securely attached to the vehicle's floor mat anchors.
- Use floor mats not too thick and designed to be properly secured on

the floor to avoid the interference with pedals.

Ensure to remove all plastic films on the carpets before installing the mats, especially for a driver's seat, the unsecured mats may cause unintended acceleration/brake. Failure to remove all plastic may result in damage or breaking the floor mat fix rings.

The following must be observed when installing ANY floor mat to the vehicle.

- Ensure that the floor mats are securely attached to the vehicle's floor mat anchor(s) before driving the vehicle.
- Do not use ANY floor mat that cannot be firmly attached to the vehicle's floor mat anchors.
- Do not stack floor mats on top of one another. (e.g., all-weather rubber mat on top of a carpeted floor mat.) Only a single floor mat should be installed in each position.

Infotainment system

* NOTICE

If you install an aftermarket HID head lamp, your vehicle's audio and electronic device may malfunction.

* INFORMATION

The infotainment system may change after software updates. For more information, refer to the user's manual provided in the infotainment system and the quick reference guide.

Over-The-Air (OTA) Software Update (if equipped)

The Over-The-Air software update feature allows you to wirelessly update software to the latest version. Using this feature, you can keep your vehicle system up to date with the latest software.

Downloading Software

The latest software can be downloaded automatically while driving. After the latest software has been successfully downloaded, you will receive a notification on your phone or the vehicle screen that the software update is ready to install.

Approving Software Update



1 Update Now

2 Later

After the vehicle is turned off, the vehicle system will allow you to start the update.

- To start the update, press **Update Now** (1).
- To postpone the update, press **Later** (2).

Preparing software update



1 Update Now

2 Cancel Update

If you press the Start button on the screen, the vehicle will begin installing the update automatically. The following conditions must be satisfied:

- The vehicle must be off.
- The gear must be in P (Park).
- The Electronic Parking Brake (EPB) must be applied.
- The exterior lights must be turned off.
- The hood must be closed.
- The battery must be sufficient.
- The systems to be updated must not be running.
- To update immediately, press **Update Now**.
- To cancel the update, press **Cancel Update**.

* INFORMATION

The battery and system status are automatically checked by the vehicle.

Updating Software



1 Details

2 Close

You can see the progress of the update on the screen.

After the update is complete, you will receive a notification on your phone or the vehicle screen that the software update is complete.

* INFORMATION

- The screen turns off automatically after 3 minutes to save battery life. If the screen turns off automatically, you can check the update progress by pressing the ignition switch or ENGINE START/STOP button.
- After the update starts, you can exit the vehicle.
- The OTA software update feature is only available for Kia Connect service users.
- The update details may vary depending on the installed software version.
- Check the notice for the OTA software update on the Kia website.
- If the update fails, the update recovery will automatically proceed. If you want to retry the software update, even after a successful recovery, contact an authorized Kia call center.
- If the update or recovery fails, contacting an authorized Kia dealer.
- After the update is complete, it may provide new functions or improve-

ments. For more information, see "Over-The-Air Software Update" page on the Kia webpage, scan the QR code on the infotainment screen or refer to the user manual in the **Customer Center** → **Download Center**.

* NOTICE

- Observe the following restrictions during the update.
 - You cannot use the vehicle during the update. Be sure to have enough time for the update, and safely park the vehicle before starting the update process.
 - You cannot use remote features, including remote start.
 - The vehicle cannot be charged. Charge your vehicle after completing the update.
 - The Rear Occupant Alert may not work. Visually check if there are any occupants in the rear seat after the update starts.
 - If the digital key function is included in the update history, the door lock/unlock function through digital key or fingerprint authentication may not work. Check the notice and use the smart key button to lock or unlock the door if the digital key function is updated.
- The update will automatically cancel if any vehicle conditions required for the update are changed before starting the update.
- Once the update has started, you cannot cancel the update.
- You cannot use the OTA software update feature if you modify or replace any vehicle software.

- Do not open the hood or replace the battery in the vehicle during the update. The update may fail.
- Note that the high-voltage-related module for charging the 12 V battery may activate during the software update.
- If a diagnostic tool of any kind is connected to the vehicle On-board Diagnostic (OBD) terminal, the vehicle cannot be updated. The vehicle can be updated by removing the diagnostic tool connected to the OBD terminal and then restarting the vehicle.
- If the update is not complete successfully, contact Kia.
- Vehicle reception must be identified to safely install any downloaded software.
- Vehicle signal strength, must be strong (above -82 dBm) to safely install any downloaded software.

Antenna



Shark-fin antenna transmit and receive signals such as AM/FM and GPS. Additional signals are sent and received according to vehicle options.

* NOTICE

- Be careful of antenna damage by checking the height of the vehicle before entering low-ceiling spaces such as automated parking lots or automated washing machines.
- Be careful not to contact the antenna when loading cargo on the roof rack. Antenna transmission/reception performance may be degraded.

USB port

Press the button (1) and when the USB port and charger light turns on (2), you can use the USB port to plug in a USB.



AI Assistant

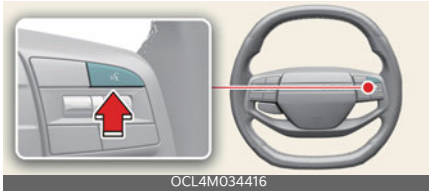

AI Assistant can be operated using voice recognition.

Operation

Press the AI Assistant button or say "Hey, Kia."

- Example (Vehicle control)
 - "Turn on the air conditioner."
 - "Turn off the air conditioner."
- Example (Question)
 - "Can you explain why the ocean is blue in a way that a 7-year-old can understand?"

* NOTICE

AI assistants may provide inaccurate answers. Please check important details separately.

Declaration of Conformity

IC

This device complies with Industry Canada's licence-exempt RSSs.

Operation is subject to the following two conditions:

1. This device may not cause interference; and
2. This device must accept any interference, including interference that may cause undesired operation of the device

Le présent appareil est conforme aux CNR d'Industrie Canada applicables aux appareils radio exempts de licence.

L'exploitation est autorisée aux deux conditions suivantes:

- 1) l'appareil ne doit pas produire de brouillage, et
- 2) l'utilisateur de l'appareil doit accepter tout brouillage radioélectrique subi, même si le brouillage est susceptible d'en compromettre le fonctionnement.

Be sure the exhaust system does not leak.....	5-3
Before driving	5-3
Key positions.....	5-5
• Ignition switch positions.....	5-5
ENGINE START/STOP button.....	5-7
• Illuminated ENGINE START/STOP button.....	5-7
• ENGINE START/STOP button position	5-7
• Starting the engine.....	5-8
• Starting the engine with smart key.....	5-9
Intelligent variable transmission (IVT).....	5-10
• Intelligent Variable Transmission (IVT) operation	5-10
• Shift-lock system.....	5-13
• Good driving practices	5-14
Automatic transmission.....	5-16
• Automatic transmission operation	5-16
• Shift-lock system.....	5-19
• Shift-lock system.....	5-20
• Ignition key interlock system	5-20
• Good driving practices	5-20
• Moving up a steep grade from a standing start	5-21
Brake system.....	5-22
• Power brakes.....	5-22
• High Performance Brake.....	5-23
• Electronic Parking Brake (EPB).....	5-24
• AUTO HOLD	5-28
• Anti-lock Brake System (ABS)	5-30
• Electronic Stability Control (ESC) system.....	5-32
• Vehicle Stability Management (VSM) system.....	5-34
• Hill-start Assist Control (HAC)	5-35
• Good braking practices.....	5-35

5 Driving your vehicle

Vehicle Auto Shut-off system	5-36
• Requirements for activation.....	5-36
• Resetting the time	5-36
• Canceling the Vehicle Auto Shut-off system.....	5-37
Drive mode integrated control system	5-37
• Drive mode	5-37
Economical operation	5-38
Special driving conditions	5-40
Winter driving	5-42
Trailer towing	5-45
Vehicle load limit	5-45
• Steps For Determining Correct Load Limit —	5-46
• Certification label	5-47
Vehicle weight	5-48
Overloading	5-49

Driving your vehicle

Be sure the exhaust system does not leak.

The exhaust system should be checked whenever the vehicle is raised to change the oil or for any other purpose.

If you hear a change in the sound of the exhaust or if you drive over something that strikes the underside of the vehicle, have the exhaust system checked as soon as possible by an authorized Kia dealer.

WARNING

Engine exhaust

Do not inhale exhaust fumes or leave your engine running in an enclosed area for a prolonged time. Exhaust fumes contain carbon monoxide, a colorless and odorless gas that can cause unconsciousness and death by asphyxiation.

WARNING

Open trunk

Do not drive with the trunk open. Poisonous exhaust gases can enter the passenger compartment. If you must drive with the trunk open proceed as follows:

1. Close all windows.
2. Open side vents.
3. Set the air intake control at "Fresh", the air flow control at "Floor" or "Face", and the fan at the highest speed.

Before driving

Before entering your Kia, examine it and its surroundings. After getting into the vehicle, you should check a number of things before driving.

Before entering vehicle

- Be sure that all windows, outside mirror(s), and outside lights are clean.
- Check the condition of the tires.
- Check under the vehicle for any sign of leaks.
- Be sure there are no obstacles behind you if you intend to back up.

Necessary inspections

Fluid levels such as engine oil, engine coolant, brake fluid, and washer fluid should be checked on a regular basis, at the exact interval depending on the fluid. Further details are provided in "Maintenance" on page 8-3.

WARNING

Distracted driving

Focus on the road while driving. The driver's primary responsibility is in the safe and legal operation of the vehicle. Use of any hand-held devices, other equipment or vehicle systems that distract the driver should not be used during vehicle operation.

Before starting

- Close and lock all doors.
- Position the seat so that all controls are easily reached.
- Buckle your seat belt.
- Adjust the inside and outside rearview mirrors.
- Be sure that all lights work.
- Check all gauges.
- Check the operation of warning lights when the ENGINE START/STOP button is turned to the ON position.
- Release the parking brake and make sure the brake warning light is off.

For safe operation, be sure you are familiar with your Kia and its equipment.

WARNING

When you intend to park or stop the vehicle with the engine on, be careful not to depress the accelerator pedal for a long time. It may overheat the engine or exhaust system and cause a fire.

WARNING

Check surroundings

Always check the surrounding areas near your vehicle for people, especially children, before putting a vehicle into D (Drive) or R (Reverse).

WARNING

Loose objects

Securely store items in your vehicle. When you make a sudden stop or turn the steering wheel rapidly, loose objects may drop on the floor and could interfere with the operation of the foot pedals, possibly causing an accident.

WARNING

Driving under the influence

Do not drive while under the influence of alcohol, drugs, or other impairing substances. Drinking and driving is dangerous. Even a small amount of alcohol will affect your reflexes, perceptions and judgment.

Driving while under the influence of drugs or other impairing substances is as dangerous as or more dangerous than driving drunk.

WARNING

Proper footwear

Always wear appropriate shoes when operating your vehicle. Unsuitable shoes (high heels, ski boots, sandals, etc.) may interfere with your ability to use the brake and accelerator pedals.

Key positions (if equipped)

Ignition switch positions

LOCK



The steering wheel locks to protect against theft. The ignition key can be removed only in the LOCK position.

ACC (Accessory)

The steering wheel is unlocked and electrical accessories are operative.

* NOTICE

If difficulty is experienced turning the ignition switch to the ACC position, turn the key while turning the steering wheel right and left to release tension.

ON

The warning lights can be checked before the engine is started. This is the normal running position after the engine is started.

Do not leave the ignition switch ON if the engine is not running to prevent battery discharge.

START

Turn the ignition switch to the START position to start the engine. The engine will turn over until you release the key; then it returns to the ON position. The

brake warning lamp can be checked in this position.

⚠ WARNING

Ignition switch

- Never turn the ignition switch to LOCK or ACC while the vehicle is moving. This would result in loss of directional control and braking function, which could cause an accident.
- The anti-theft steering column lock (if equipped) is not a substitute for the parking brake. Before exiting, always make sure the gear is shifted to P (Park) position, set the parking brake fully and shut the engine off. Unexpected and sudden vehicle movement may occur if these precautions are not taken.
- Never reach for the ignition switch, or any other controls through the steering wheel while the vehicle is in motion. The presence of your hand or arm in this area could cause a loss of vehicle control, an accident and serious bodily injury or death.
- Do not place any movable objects around the driver's seat as they may move while driving, interfere with the driver and lead to an accident.

Starting the engine

⚠ WARNING

- Always wear appropriate shoes when operating your vehicle. Unsuitable shoes (high heels, ski boots, etc.) may interfere with your ability to use the brake, accelerator pedal, and clutch (if equipped).
- Do not start the vehicle with the accelerator pedal depressed. The vehicle can move and lead to an accident.

- Wait until the engine rpm is normal. The vehicle may suddenly move if the brake pedal is released when the rpm is high.

Starting the gasoline engine

1. Make sure the parking brake is applied.
2. **Manual Transmission**- Depress the clutch pedal fully and shift the Transmission into Neutral. Keep the clutch pedal and brake pedal depressed while turning the ignition switch to the start position.
Automatic Transmission - Place the Transmission shift lever in P (Park). Depress the brake pedal fully. You may start the engine when the gear is in the N (neutral) position.
3. Turn the ignition switch to START and hold it there until the engine starts (a maximum of 10 seconds), then release the key.

It should be started **without depressing the accelerator pedal.**

4. Do not wait for the engine to warm up while the vehicle remains stationary. Start driving at moderate speeds. (Fast accelerating and decelerating should be avoided.)

⚠ CAUTION

If the engine stalls while you are in motion, do not attempt to move the shift lever to the P (Park) position. If traffic and road conditions permit, you may put the shift lever in the N (Neutral) position while the vehicle is still moving and turn the ignition switch to the START position in an attempt to restart the engine.

⚠ CAUTION

- Do not engage the starter for more than 10 seconds. If the engine stalls or fails to start, wait 5 to 10 seconds before reengaging the starter. Improper use of the starter may damage it.
- Do not turn the ignition switch to the START position with the engine running. It may damage the starter.

ENGINE START/STOP button (if equipped)

Illuminated ENGINE START/STOP button



The light will turn off after about 30 seconds when the door is closed. It will also turn off immediately when the theft-alarm system is armed.

ENGINE START/STOP button position

Your vehicle is equipped with four different ignition positions.

OFF

To turn off the engine (START/RUN position) or vehicle power (ON position), press the ENGINE START/STOP button with the shift lever in the P (Park) position. When you press the ENGINE START/STOP button and the gear is not in the P (Park) position, the ENGINE START/STOP button will not change to the OFF position but to the ACC position.

Vehicles equipped with anti-theft steering column lock

The steering wheel locks when the ENGINE START/STOP button is in the OFF position to protect you against theft.

It locks when the door is opened.

If the steering wheel is not locked properly when you open the driver's door, the warning chime will sound. Try locking

the steering wheel again. If the problem is not resolved, have the system checked by an authorized Kia dealer.

If the ENGINE START/STOP button is in the OFF position after the driver's door is opened, the steering wheel will not lock and the warning chime will sound. Close the door - the steering wheel will lock and the warning chime will stop.

* NOTICE

If the steering wheel doesn't unlock properly, the ENGINE START/STOP button will not operate. Press the ENGINE START/STOP button while turning the steering wheel right and left to release tension.

* NOTICE

You can turn off the engine (START/RUN) or vehicle power (ON), only when the vehicle is not in motion.

* NOTICE

In an emergency while the vehicle is in motion, you are able to turn the engine off and to the ACC position by pressing the ENGINE START/STOP button for more than 2 seconds or 3 times repeatedly within 3 seconds.

If the vehicle is still moving, to restart the vehicle:

- Press the ENGINE START/STOP button when vehicle speed is 5 km/h (3 mph) or higher.

ACC (Accessory)

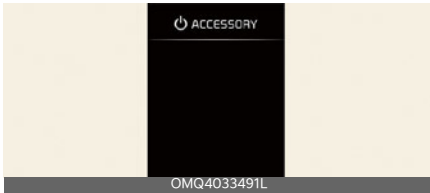

Press the ENGINE START/STOP button while it is in the OFF position without depressing the brake pedal.

The steering wheel unlocks and electrical accessories are operational.

If the ENGINE START/STOP button is in the ACC position for more than 1 hour, the button is turned off automatically to prevent battery discharge.

ON

Press the ENGINE START/STOP button while it is in the ACC position without depressing the brake pedal.

The warning lights can be checked before the engine is started. Do not leave the ENGINE START/STOP button in the ON position for a long time. The battery may discharge because the engine is not running.

* NOTICE

If you leave the ENGINE START/STOP button in the ACC or ON position for a long time, the battery will discharge.

START/RUN

To start the engine, depress the brake pedal and press the ENGINE START/STOP button with the shift lever in the P (Park) or the N (Neutral) position. For your safety, start the engine with the shift lever in the P (Park) position.

* NOTICE

If you press the ENGINE START/STOP button without pressing the brake pedal, the engine will not start and the ENGINE START/STOP button changes as follows: OFF → ACC → ON → OFF or ACC

⚠ WARNING

- Never press the ENGINE START/STOP button while the vehicle is in motion. This would result in loss of directional control and braking function, which could cause an accident.
- Before leaving the driver's seat, always make sure the shift lever is engaged in P (Park), set the parking brake fully and shut the engine off. Unexpected and sudden vehicle movement may occur if these precautions are not taken.
- Never reach for the ENGINE START/STOP button or any other controls through the steering wheel while the vehicle is in motion. The presence of your hand or arm in the area could cause loss of vehicle control, an accident and serious bodily injury or death.
- Do not place any movable objects around the driver's seat as they may move while driving, interfere with the driver and lead to an accident.

Starting the engine

⚠ WARNING

- Do not start the vehicle with the accelerator pedal engaged. The vehicle can move and lead to an accident.
- Wait until the engine rpm is normal. The vehicle may suddenly move if the

brake pedal is released when the rpm is high.

1. Make sure the smart key is located inside the vehicle and close the driver seat. The vehicle may not start if it is not located near the driver seat.
2. Make sure the parking brake is applied.
3. Make sure the shift lever is in P (Park). Press the brake pedal fully.
You can also start the engine when the shift lever is in the N (Neutral) position.
4. Press the ENGINE START/STOP button.
Make sure that the accelerator pedal is not pressed.
5. Do not wait for the engine to warm up while the vehicle remains stationary. Start driving at moderate engine speeds. (Steep accelerating and decelerating should be avoided.)

Starting the engine with smart key

When the vehicle doors are opened or when the ENGINE START/STOP button is pressed, the vehicle will check for the smart key.

If the smart key is not in the vehicle, the  indicator and a message "Key is not in the vehicle" will appear on the instrument cluster and LCD display. If all doors are closed, the chime will sound for 5 seconds. The indicator or warning will turn off while the vehicle is moving. Always have the smart key with you.

WARNING

The engine will start, only when the smart key is in the vehicle. Never allow children or any person who is unfamiliar

with the vehicle to touch the ENGINE START/STOP button or related parts. Pushing the ENGINE START/STOP button while the smart key is in the vehicle may result in unintended engine activation and/or unintended vehicle movement.

CAUTION

If the engine stalls while the vehicle is in motion, do not attempt to move the shift lever to the P (Park) position. If the traffic and road conditions permit, you may put the gear in the N (Neutral) position while the vehicle is still moving and press the ENGINE START/STOP button to restart the engine.

* NOTICE

- If the battery is weak or the smart key does not work properly, you can start the engine by pressing the ENGINE START/STOP button with the smart key.

When you press the ENGINE START/STOP button directly with the smart key, the smart key should contact the button at a right angle.



- If the stop light fuse is blown, you cannot start the engine normally. Replace the fuse with a new one. If not possible, you can start the engine by pressing the ENGINE START/STOP button for 10 seconds while it is in the ACC position. The engine can start without pressing the brake pedal but

for your safety, always depress the brake pedal before starting the engine.



CAUTION

To avoid vehicle damage, do not press the ENGINE START/STOP button for more than 10 seconds, except when the stop lamp fuse is blown.

Intelligent variable transmission (IVT) (if equipped)

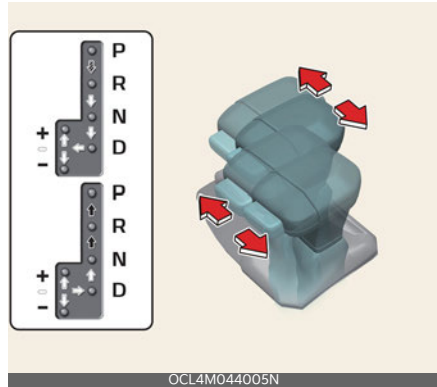
The Intelligent Variable Transmission (IVT) automatically shifts depending on speed, accelerate pedal position. The individual speeds are selected automatically, depending on the position of the shift lever.



-  Depress the brake pedal and the lock release button when shifting.
-  Press the lock release button when shifting.
-  The shift lever can be shifted freely.

Intelligent Variable Transmission (IVT) operation

For smooth operation, depress the brake pedal when shifting from N (Neutral) to a forward or reverse gear.

WARNING

Intelligent Variable Transmission (IVT)

- Always check the surrounding areas near your vehicle for people, especially children, before shifting a car into D (Drive) or R (Reverse).
- Before leaving the driver's seat, always make sure the shift lever is in

the P (Park) position; then set the parking brake fully and shut the engine off. Unexpected and sudden vehicle movement can occur if these precautions are not followed in the order identified.

- Do not use the engine brake (shifting from a high gear to lower gear) rapidly on slippery roads.

The vehicle may slip causing an accident.

LCD display for warning message

A warning message is displayed on the LCD.

Transmission overheated

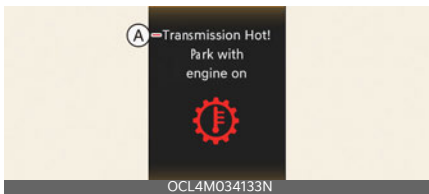

A: Transmission Hot! Park with engine on

- When driving under severe conditions such as repeated sudden starts and sudden acceleration, the transmission may overheat, and a warning sound and a warning message appear on the instrument cluster due to the self-protection mode.
- If this occurs, pull over to a safe location, stop the vehicle with the engine running, apply brake, shift the gear to P (Park) and allow the transmission to cool.
- If the warning message remains on, have the system checked by an authorized Kia dealer to prevent unexpected accidents.

Vehicle power limited

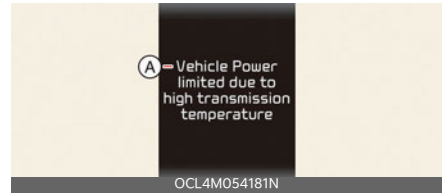

A: Vehicle Power limited due to high transmission temperature

- If the transmission continues to overheat and reaches its maximum temperature, the above warning message appears. The vehicle limits transmission power by its self-protection mode.
- Normal driving is restricted until the transmission temperature decreases. After moving the vehicle to a safe place, shift the gear to P (Park) with the engine running and wait several minutes until the warning on the screen disappears.
- If the warning message remains on, have the system checked by an authorized Kia dealer to prevent unexpected accidents.

Transmission cooled

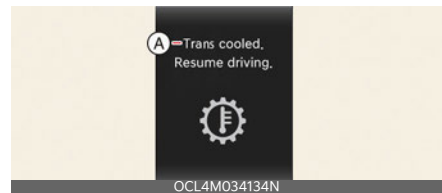

A: Trans cooled. Resume driving.

- When the message "Trans cooled. Resume driving" appears you can resume driving your vehicle.

⚠ CAUTION

- To avoid damage to your transmission, do not accelerate the engine in R (Reverse) or any forward gear position with the brakes on.
- When stopped on an incline, do not hold the vehicle stationary with engine power. Use the service brake or the parking brake.
- Do not shift from N (Neutral) or P (Park) into D (Drive), or R (Reverse) when the engine is above idle speed.

Transmission ranges

The indicator in the instrument cluster displays the shift lever position when the ignition switch is in the ON position.

P (Park)

Always come to a complete stop before shifting into P (Park). This position locks the transmission and prevents the front wheels from rotating.

⚠ WARNING

- Shifting into P (Park) while the vehicle is in motion will cause the drive wheels to lock which will cause you to lose control of the vehicle.
- Do not use the P (Park) position in place of the parking brake. Always make sure the shift lever is latched in the P (Park) position and set the parking brake fully.
- Never leave a child unattended in a vehicle.

⚠ CAUTION

The transmission may be damaged if you shift into P (Park) while the vehicle is in motion.

⚠ CAUTION

The RPM (revolution per minute) may increase or decrease when performing the Intelligent Variable Transmission (IVT) self-diagnosis.

R (Reverse)

Use this position to drive the vehicle backward.

⚠ CAUTION

Always come to a complete stop before shifting into or out of R (Reverse); you may damage the transmission if you shift into R while the vehicle is in motion, except as explained in "Special driving conditions" on page 5-40.

N (Neutral)

The wheels and transmission are not engaged. The vehicle will roll freely even on the slightest incline unless the parking brake or service brakes are applied.

⚠ WARNING

Do not drive with the shift lever in N (Neutral).

The engine brake will not work and lead to an accident.

D (Drive)

This is the normal forward driving position. The transmission will automatically shift, providing the best fuel economy and power.

For extra power when passing another vehicle or climbing grades, depress the accelerator fully, at which time the trans-

mission will automatically downshift to the next lower gear.

* NOTICE

Always come to a complete stop before shifting into D (Drive).

Manual mode



Whether the vehicle is stationary or in motion, manual mode is selected by pushing the shift lever from the D (Drive) position into the manual gate. To return to D (Drive) range operation, push the shift lever back into the main gate.

Manual mode manages the driving dynamics by automatically adjusting the steering effort, and the engine and transmission control logic for enhanced driver performance.

In manual mode, moving the shift lever backwards and forwards will allow you to make gearshifts rapidly. In contrast to a manual transmission, the manual mode allows gearshifts with the accelerator pedal depressed.

- Up (+): Push the lever forward once to shift up one gear.
- Down (-): Pull the lever backwards once to shift down one gear.

* NOTICE

- The driver must execute upshifts in accordance with road conditions, taking care to keep the engine speed below the red zone.

- Only the 8 forward gears can be selected. To reverse or park the vehicle, move the shift lever to the R (Reverse) or P (Park) position as required.
- Downshifts are made automatically when the vehicle slows down. When the vehicle stops, 1st gear is automatically selected.
- When the engine rpm approaches the red zone shift points are varied to upshift automatically.
- To maintain the required levels of vehicle performance and safety, the system may not execute certain gearshifts when the shift lever is operated.
- When driving on a slippery road, push the shift lever forward into the + (up) position. This causes the transmission to shift into the 2nd gear which is better for smooth driving on a slippery road. Push the shift lever to the - (down) side to shift back to the 1st gear.
- When manual mode is activated:
 - The engine rpm will tend to remain raised over a certain length of time even after releasing the accelerator.
 - Upshifts are delayed when accelerating.
- The fuel efficiency may decrease.

Shift-lock system

For your safety, the automatic transmission has a shift-lock system which prevents shifting the transmission from P (Park) into R (Reverse) unless the brake pedal is depressed.

To shift the transmission from P (Park) into R (Reverse):

1. Depress and hold the brake pedal.

2. Start the engine or turn the ignition switch to the ON position.
3. Move the shift lever.

If the brake pedal is repeatedly depressed and released with the shift lever in the P (Park) position, a chattering noise near the shift lever may be heard. This is a normal condition.

⚠ WARNING

Always fully depress the brake pedal before and while shifting out of the P (Park) to avoid inadvertent motion of the vehicle which could injure persons in or around the vehicle.

Shift-lock override

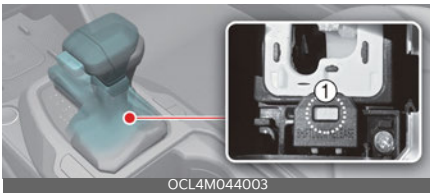

If the shift lever cannot be moved from the P (Park) position into R (Reverse) position with the brake pedal depressed, continue depressing the brake, do the following:

1. Place the ignition switch or ENGINE START/STOP button in the LOCK/OFF position.
2. Apply the parking brake.
3. Carefully remove the knob boots covering the shift-lock release access hole (1).
4. Insert a tool (e.g., flathead screwdriver) into the access hole and press down on the tool.
5. Move the shift lever.
6. Remove the tool from the shift lock override access hole and reinstall the knob boots.

If the shift lever does not move after performing this procedure, have the system checked by an authorized Kia dealer.

Good driving practices

- Never move the shift lever from P (Park) or N (Neutral) to any other position with the accelerator pedal depressed.
- Never move the shift lever into P (Park) when the vehicle is in motion.
- Be sure the vehicle is completely stopped before you attempt to shift into R (Reverse) or D (Drive).
- Never take the vehicle out of gear and coast down a hill. This may be extremely hazardous. Always leave the vehicle in gear when moving.
- Do not "ride" the brakes. This can cause them to overheat and malfunction. Instead, when you are driving down a long hill, slow down and shift to a lower gear. When you do this, engine braking will help slow down the vehicle.
- Slow down before shifting to a lower gear. Otherwise, the lower gear may not be engaged.
- Always use the parking brake. Do not depend on placing the transmission in P (Park) to keep the vehicle from moving.
- Exercise extreme caution when driving on a slippery surface. Be especially careful when braking, accelerating or shifting gears. On a slippery surface, an abrupt change in vehicle speed can cause the drive wheels to lose traction and the vehicle to go out of control.

- Optimum vehicle performance and economy is obtained by smoothly depressing and releasing the accelerator pedal.

⚠ WARNING

- When driving uphill or downhill, always shift to D (Drive) for driving forward or shift to R (Reverse) for driving backwards, and check the gear position indicated on the cluster before driving.

Driving in the opposite direction of the selected gear can lead to a dangerous situation by shutting off the engine and affecting the braking performance.

- Always buckle-up! In a collision, an unbelted occupant is significantly more likely to be seriously injured or killed than a properly belted occupant.
- Avoid high speeds when cornering or turning.
- Do not make quick steering wheel movements, such as sharp lane changes or fast, sharp turns.
- The risk of a rollover is greatly increased if you lose control of your vehicle at highway speeds.
- Losing control often occurs if two or more wheels drop off the roadway and the driver oversteers to reenter the roadway.
- In the event your vehicle leaves the roadway, do not steer sharply. Instead, slow down before pulling back into the travel lanes.
- Never exceed posted speed limits.

⚠ WARNING

If your vehicle becomes stuck in snow, mud, sand, etc., then you may attempt to rock the vehicle free by moving it forward and backward. Do not attempt this procedure if people or objects are anywhere near the vehicle. During the rocking operation the vehicle may suddenly move forward or backward as it becomes unstuck, causing injury or damage to nearby people or objects.

Moving up a steep grade from a standing start

To move up a steep grade from a standing start:

1. Depress the brake pedal, shift the shift lever to D (Drive).
2. Select the appropriate gear depending on load weight and steepness of the grade, and release the parking brake.
3. Depress the accelerator gradually while releasing the service brakes.

When accelerating from a stop on a steep hill, the vehicle may have a tendency to roll backwards.



⚠ WARNING

When you start driving after the car was stopped on a hill, even though the shift lever is in D (Driving) position, if you do not step on the accelerator pedal or brake pedal, the car may roll backward, resulting in a fatal accident.

Always come to a complete stop before shifting into D (Drive).

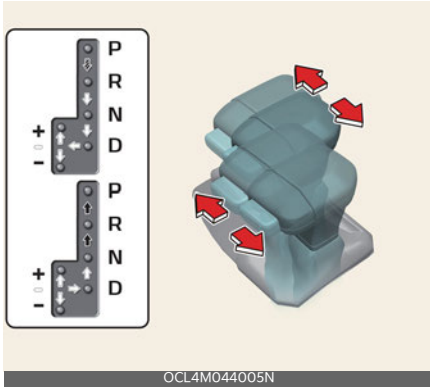
Automatic transmission



-  Depress the brake pedal and the lock release button when shifting.
-  Press the lock release button when shifting.
-  The shift lever can be shifted freely.

Automatic transmission operation

The automatic transmission has 6 and 8 forward speeds and one reverse speed. The individual speeds are selected automatically, depending on the position of the shift lever.

* NOTICE

If the battery has been disconnected, the first few shifts on a new vehicle may be somewhat abrupt. This is a normal condition, and the shifting sequence will adjust after shifts are cycled a few times by the TCM (Transmission Control Module) or PCM (Powertrain Control Module).

For smooth operation, depress the brake pedal when shifting from N (Neutral) to a forward or reverse gear.

⚠ WARNING

Automatic transmission

- Always check the surrounding areas near your vehicle for people, especially children, before shifting a vehicle into D (Drive) or R (Reverse).
- Before leaving the driver's seat, always make sure the shift lever is in the P (Park) position; then set the parking brake fully and shut the engine off. Unexpected and sudden vehicle movement can occur if these precautions are not followed in the order identified.
- Do not shift into N (Neutral) while driving. The engine brake may not work causing an accident.
- Do not use the engine brake (shifting from a high gear to lower gear) rapidly on slippery roads. The vehicle may slip causing an accident.
- When driving uphill or downhill, always shift to D (Drive) for driving forward or shift to R (Reverse) for driving backwards. Check the gear position indicated on the cluster before driving. Driving in the opposite direction of the selected gear can lead to a dangerous situation by shutting off the engine and affecting the braking performance.

⚠ CAUTION

- To avoid damage to your transmission, do not accelerate the engine in R (Reverse) or any forward gear position with the brakes on.
- When stopped on an incline, do not hold the vehicle stationary with engine power. Use the service brake or the parking brake.

- Do not shift from N (Neutral) or P (Park) into D (Drive), or R (Reverse) when the engine is above idle speed.

LCD display for warning message

A warning message is displayed on the LCD.

Transmission overheated

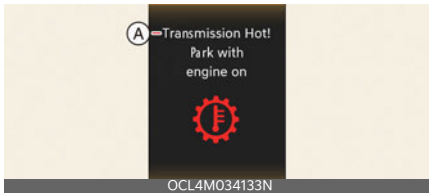

A: Transmission Hot! Park with engine on

- When driving under severe conditions such as repeated sudden starts and sudden acceleration, the transmission may overheat, and a warning sound and a warning message appear on the instrument cluster due to the self-protection mode.
- If this occurs, pull over to a safe location, stop the vehicle with the engine running, apply brake, shift the gear to P (Park) and allow the transmission to cool.
- If the warning message remains on, have the system checked by an authorized Kia dealer to prevent unexpected accidents.

Vehicle power limited



A: Vehicle Power limited due to high transmission temperature

- If the transmission continues to overheat and reaches its maximum temperature, the above warning message appears. The vehicle limits transmission power by its self-protection mode.
- Normal driving is restricted until the transmission temperature decreases. After moving the vehicle to a safe place, shift the gear to P (Park) with the engine running and wait several minutes until the warning on the screen disappears.
- If the warning message remains on, have the system checked by an authorized Kia dealer to prevent unexpected accidents.

Transmission cooled

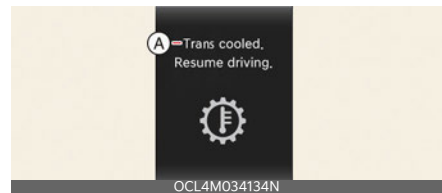

A: Trans cooled. Resume driving.

- When the message "Trans cooled. Resume driving" appears you can resume driving your vehicle.

Transmission ranges

The indicator in the instrument cluster displays the shift lever position when the

ENGINE START/STOP button is in the ON position.

P (Park)

Always come to a complete stop before shifting into P (Park). This position locks the transmission and prevents the front wheels from rotating.

⚠ WARNING

- Shifting into P (Park) while the vehicle is in motion will cause the drive wheels to lock which will cause you to lose control of the vehicle.
- Do not use the P (Park) position in place of the parking brake. Always make sure the shift lever is set in the P (Park) position and fully set the parking brake.
- Never leave a child unattended in a vehicle.

⚠ CAUTION

The transmission may be damaged if you shift into P (Park) while the vehicle is in motion.

R (Reverse)

Use this position to drive the vehicle backward.

⚠ CAUTION

Always come to a complete stop before shifting into or out of R (Reverse); you may damage the transmission if you shift into R while the vehicle is in motion, except when "Rocking the vehicle" on page 5-40.

N (Neutral)

The wheels and transmission are not engaged. The vehicle will roll freely even on the slightest incline unless the parking brake or service brake is applied.

⚠ WARNING

Do not drive with the shift lever in N (Neutral).

The engine brake will not work and can lead to an accident.

⚠ CAUTION

- After the ignition switch or ENGINE START/STOP button has been turned off, the electronic parking brake cannot be disengaged.
- For EPB (Electronic Parking Brake) equipped vehicles with AUTO HOLD function used while driving, if the ignition button has been turned "OFF", the electronic parking brake will be engaged automatically. The AUTO HOLD function should be turned off before the ignition button is turned off.

D (Drive)

This is the normal forward driving position. The transmission will automatically shift through the 8 gear sequence, providing the best fuel economy and power.

For extra power when passing another vehicle or climbing grades, depress the accelerator fully, at which time the transmission will automatically downshift to the next lower gear.

* NOTICE

Always come to a complete stop before shifting into D (Drive).

Manual mode



Whether the vehicle is stationary or in motion, manual mode can be selected by pushing the shift lever from the D (Drive) position into the manual gate. To return to D (Drive) range operation, push the shift lever back into the main gate.

Manual mode manages the driving dynamics by automatically adjusting the steering effort, and the engine and transmission control logic for enhanced driver performance.

In manual mode, moving the shift lever backwards and forwards will allow you to select the desired range of gears for the current driving conditions.

- Up (+): Push the lever forward once to shift up one gear.
- Down (-): Pull the lever backwards once to shift down one gear.

* NOTICE

- If the driver presses the lever to + (Up) or - (Down) position, the transmission may not make the requested gear change if the next gear is outside the allowable engine rpm range.
- The driver must execute upshifts in accordance with road conditions, taking care to keep the engine speed below the red zone.
- Only the 8 forward gears can be selected. To reverse or park the vehicle, move the shift lever to the R (Reverse) or P (Park) position as

required and only when the vehicle is stopped and not moving.

- Downshifts are made automatically when the vehicle slows down. When the vehicle stops, 1st gear is automatically selected.
- When the engine rpm approaches the red zone shift points are varied to upshift automatically.
- To maintain the required levels of vehicle performance and safety, the system may not execute certain gear-shifts when the shift lever is operated.
- When driving on a slippery road, push the shift lever forward into the + (up) position. This causes the transmission to shift into the 2nd gear which is better for smooth driving on a slippery road. Push the shift lever to the - (down) side to shift back to the 1st gear.

Shift-lock system

For your safety, the automatic transmission has a shift-lock system which prevents shifting the transmission from P (Park) into R (Reverse) unless the brake pedal is depressed.

To shift the transmission from P (Park) into R (Reverse):

1. Depress and hold the brake pedal.
2. Start the engine or turn the ignition switch to the ON position.
3. Move the shift lever.

If the brake pedal is repeatedly depressed and released with the shift lever in the P (Park) position, a chattering noise near the shift lever may be heard. This is a normal condition.

⚠ WARNING

Always fully depress the brake pedal before and while shifting out of the P (Park) to avoid inadvertent motion of the vehicle which could injure persons in or around the vehicle.

Shift-lock system

For your safety, the automatic transmission has a shift-lock system which prevents shifting the transmission from P (Park) into R (Reverse) unless the brake pedal is depressed.

To shift the transmission from P (Park) into R (Reverse):

1. Depress and hold the brake pedal.
2. Start the engine or turn the ignition switch to the ON position.
3. Move the shift lever.

If the brake pedal is repeatedly depressed and released with the shift lever in the P (Park) position, a chattering noise near the shift lever may be heard. This is a normal condition.

⚠ WARNING

Always fully depress the brake pedal before and while shifting out of the P (Park) to avoid inadvertent motion of the vehicle which could injure persons in or around the vehicle.

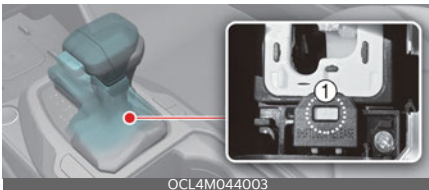
Shift-lock override

If the shift lever cannot be moved from the P (Park) position into R (Reverse) position with the brake pedal depressed, continue depressing the brake, do the following:

1. Place the ignition switch or ENGINE START/STOP button in the LOCK/OFF position.
2. Apply the parking brake.
3. Carefully remove the knob boots covering the shift-lock release access hole (1).
4. Insert a tool (e.g., flathead screwdriver) into the access hole and press down on the tool.
5. Move the shift lever.
6. Remove the tool from the shift lock override access hole and reinstall the knob boots.

If the shift lever does not move after performing this procedure, have the system checked by an authorized Kia dealer.

Ignition key interlock system

If your vehicle is equipped with ENGINE START/STOP button, the button will not change to the OFF position unless the shift lever is in the P (Park) position.

Good driving practices

- Never move the shift lever from P (Park) or N (Neutral) to any other position with the accelerator pedal depressed.
- Never move the shift lever into P (Park) when the vehicle is in motion.
- Be sure the vehicle is completely stopped before you attempt to shift into R (Reverse) or D (Drive).
- Never move the transmission out of gear and coast down a hill. This may be extremely hazardous. Always leave the vehicle in gear when moving.

- Do not "ride" the brakes. This can cause them to overheat and malfunction. When you are driving down a long hill, slow down and shift to a lower gear. When you do this, engine braking will help slow down the vehicle.
- Slow down before shifting to a lower gear. Otherwise, the lower gear may not be engaged.
- Always use the parking brake. Do not depend on placing the transmission in P (Park) to keep the vehicle from moving.
- Exercise extreme caution when driving on a slippery surface. Be especially careful when braking, accelerating or shifting gears. On a slippery surface, an abrupt change in vehicle speed can cause the drive wheels to lose traction and the vehicle to go out of control.
- Optimum vehicle performance and economy is obtained by smoothly depressing and releasing the accelerator pedal.
- Avoid high speeds when cornering or turning.
- Do not make quick steering wheel movements, such as sharp lane changes or fast, sharp turns.
- The risk of rollover is greatly increased if you lose control of your vehicle at highway speeds.
- Loss of control often occurs if two or more wheels drop off the roadway and the driver oversteers to reenter the roadway.
- In the event your vehicle leaves the roadway, do not steer sharply. Instead, slow down before pulling back into the travel lanes.
- Never exceed posted speed limits.

WARNING

- When driving uphill or downhill, always shift to D (Drive) for driving forward or shift to R (Reverse) for driving backwards, and check the gear position indicated on the instrument cluster before driving. Driving in the opposite direction of the selected gear can lead to a dangerous situation by shutting off the engine and affecting the braking performance.
- Always buckle-up! In a collision, an unbelted occupant is significantly more likely to be seriously injured or killed than a properly belted occupant.

WARNING

If your vehicle becomes stuck in snow, mud, sand, etc., then you may attempt to rock the vehicle free by moving it forward and backward. Do not attempt this procedure if people or objects are anywhere near the vehicle. During the rocking operation the vehicle may suddenly move forward or backward as it becomes unstuck, causing injury or damage to nearby people or objects.

Moving up a steep grade from a standing start

To move up a steep grade from a standing start:

- Depress the brake pedal, shift the shift lever to D (Drive). Select the appropriate gear depending on load weight and steepness of the grade and release the parking brake.

Brake system

Your vehicle has power-assisted brakes, parking brake, and various braking systems for safe driving.

Power brakes

Your vehicle has power-assisted brakes that adjust automatically through normal usage.

If the power-assisted brakes lose power because of a stalled engine or some other reason, you can still stop your vehicle by applying greater force to the brake pedal than you normally would. The stopping distance, however, will be longer.

When the engine is not running, the reserve brake power is partially depleted each time the brake pedal is applied. Do not pump the brake pedal when the power assist has been interrupted.

Pump the brake pedal only when necessary to maintain steering control on slippery surfaces.

* NOTICE

- When pressing the brake pedal under a certain driving or weather conditions, you may hear your car make a squealing sound or some other noises. This is not a brake malfunction but a normal phenomenon.
- When driving on the road to which deicing chemicals are applied, the vehicle may hear noises from the brake or abnormal abrasion of tires because of such deicing chemicals. You should operate brake additionally so that you can remove the deicing chemicals on the brake disk and pad under a safe traffic condition.

⚠ CAUTION

Brake Pedal

Do not drive with your foot resting on the brake pedal. This will create abnormally high brake temperatures which can cause excessive brake lining and pad wear.

⚠ WARNING

Steep hill braking

Avoid continuous application of the brakes when descending a long or steep hill by shifting to a lower gear. Continuous brake application will cause the brakes to overheat and could result in a temporary loss of braking performance.

Wet brakes may impair the vehicle's ability to safely slow down; the vehicle may also pull to one side when the brakes are applied. Applying the brakes lightly will indicate whether they have been affected in this way. Always test your brakes in this fashion after driving through deep water. To dry the brakes, apply them lightly while maintaining a safe forward speed until brake performance returns to normal.

In the event of brake failure

If service brakes fail to operate while the vehicle is in motion, you can make an emergency stop with the parking brake. The stopping distance, however, will be much greater than normal.

⚠ WARNING

Parking brake

Avoid applying the parking brake to stop the vehicle while it is moving except in an emergency. Applying the parking brake while the vehicle is moving at normal speeds can cause a sudden loss of

control of the vehicle. If you must use the parking brake to stop the vehicle, use great caution.

Brake Over Accelerator

In the event the accelerator pedal becomes stuck or entrapped, apply steady and firm pressure to the brake pedal to slow the vehicle and reduce engine power.

If you experience this condition, take the following steps:

1. Apply the brake and bring your vehicle to a safe stop.
2. Move the transmission to P (Park), switch the engine off and apply the parking brake.
3. Inspect the accelerator pedal for any interference.

If none are found and the condition persists, have your vehicle towed to an authorized Kia dealer and inspected.

Disc brakes wear indicator

When your brake pads are worn and new pads are required, you will hear a high-pitched warning sound from your front or rear brakes. You may hear this sound periodically or it may occur whenever you press the brake pedal.

Always replace the front or rear brake pads as pairs.

⚠ CAUTION

Replace brake pads

Do not continue to drive with worn brake pads. It can damage the braking system and result in costly brake repairs.

⚠ WARNING

Brake wear

Do not ignore high-pitched wear sounds from your brakes. If you ignore this audible warning, you will eventually lose braking performance, which could lead to a serious accident.

*** NOTICE**

Brake dust may accumulate on the wheels even under normal driving conditions. Some dust is inevitable as the brakes wear and contribute to brake noise.

High Performance Brake (if equipped)

As this vehicle is equipped with the High Performance Brake (large diameter brakes for enhanced braking performance), noise such as a squeal, squeak or groan in generated while braking. This is normal and the friction may create circle patterns on the disc surface. This is also a normal situation which does not affect braking performance.

*** NOTICE**

- Occasional brake noise is normal. If a continuous grinding or continuous squeal sounds are present, the brake lining may be worn out. Have the vehicle checked by an authorized Kia dealer.
- If the vehicle has continuous vibration or shudder in the steering wheel while braking, have the vehicle checked by an authorized Kia dealer.

*** NOTICE**

Frequent speeding and braking may deform components and worn the disc

brake causing vibration when braking. Prevent brake damage by avoiding excessive braking.

Brake wear, noise, vibration from excessive braking or deformation of the brakes caused by repeatedly braking in high speed, racing on tracks, etc. can be excluded from warranty coverage.



Check the brake warning light by turning the ENGINE START/STOP button ON (do not start the engine). This light will appear when the parking brake is applied with the ENGINE START/STOP button in the START or ON position.

Before driving, be sure the parking brake is fully released and the brake warning light is off.

If the brake warning light remains on after the parking brake is released while engine is running, there may be a malfunction in the brake system. Immediate attention is necessary.

If at all possible, cease driving the vehicle immediately. If that is not possible, use extreme caution while operating the vehicle and only continue to drive the vehicle until you can reach a safe location or repair shop.

Electronic Parking Brake (EPB)

After parking the vehicle, apply the EPB to prevent the vehicle from being moved by the external force.

Applying the parking brake

Applying the parking brake manually

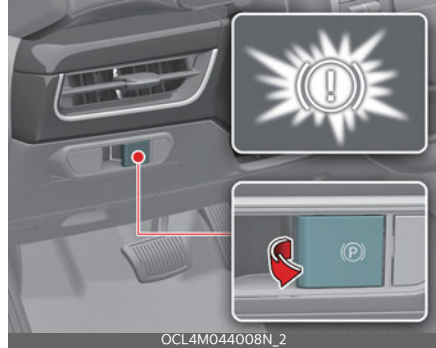

1. Depress the brake pedal.
2. Pull up the EPB switch.

Make sure the warning light comes on.

The EPB is applied automatically if the AUTO HOLD button is on when the vehicle is turned off. If you pull up the EPB switch after the vehicle is turned off, the EPB will be applied.

* NOTICE

On a steep incline or when pulling a trailer, if the vehicle does not remain at a standstill, do as follows:

1. Apply the EPB.
2. Pull up the EPB switch for more than 3 seconds.

Do not operate the EPB while the vehicle is moving except in an emergency.

* NOTICE

A click or electric brake motor whine sound may be heard while operating or releasing the EPB. These conditions are normal and indicate that the EPB is functioning properly.

Applying the parking brake automatically

The EPB is applied automatically under following conditions:

- To compensate for loss of clamping force caused by temperature difference when the brake is overheated.
- The driver turns the vehicle OFF while AUTO HOLD is operating
- Requested by other systems
- If the door is opened while the engine is running, the EPB may be automatically engaged.

* NOTICE

For EPB equipped vehicles with AUTO HOLD function used while driving, if the ENGINE START/STOP button has been turned OFF, the EPB will be engaged automatically. Therefore,

AUTO HOLD function should be turned off before the ENGINE START/STOP button is turned off.

Emergency braking

If there is a problem with the brake pedal while driving, emergency braking is possible by pulling up and holding the EPB switch. Braking is possible only while you are holding the EPB switch. However, braking distance will be longer than normal.

▲ WARNING

Do not operate the Electronic Parking Brake (EPB) while the vehicle is moving except in an emergency. Applying the EPB while the vehicle is moving at normal speeds can cause a sudden loss of control of the vehicle. If you must use

the EPB to stop the vehicle, use great caution in applying the brake.

* NOTICE

During emergency braking by the EPB, the parking brake warning light will illuminate to indicate that the system is operating.

* NOTICE

If you continuously notice a noise or burning smell when the EPB is used for emergency braking, that may indicate that your EPB is damaged. If that continues, have the system checked by an authorized Kia dealer.

Releasing the parking brake

Releasing the parking brake manually



1. Have the ENGINE START/STOP button in the ON position.
2. Press the brake pedal.
3. Make sure the gear is shifted to P (Park) position.
4. Press the EPB switch.
5. Make sure the brake warning light goes off.

Releasing the parking brake automatically

The EPB is released automatically under following conditions.

- While the vehicle engine is on and the brake pedal is depressed, the EPB will be released automatically if the gear is shifted from P (Park) or N (Neutral) to R (Reverse) or D (Drive). For your safety, check if the brake warning light is turned off and release the brake pedal.
- Under the following conditions, the EPB is released automatically after slowly depressing the accelerator pedal. For your safety, check if the brake warning light is turned off.
 - The vehicle engine is running
 - The driver's seat belt is fastened
 - The driver's door, hood, trunk is closed
 - The gear is in R (Reverse) or D (Drive)

* NOTICE

- You can engage the EPB even though the ENGINE START/STOP button is in the OFF position, but you cannot release it.
- Depress the brake pedal and release the parking brake manually with the EPB switch when you drive downhill or when backing up the vehicle.

* NOTICE

- If the parking brake warning light is still on even though the EPB has been released, have the system checked by an authorized Kia dealer.
- Do not drive your vehicle with the EPB applied. It may cause excessive brake pad and brake rotor wear.

EPB warning messages

To release EPB, fasten seatbelt, close door, hood, and trunk/lift-gate

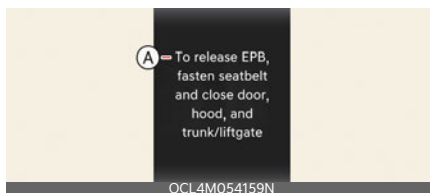

A: To release EPB, fasten seatbelt and close door, hood, and trunk/liftgate

- If you try to drive off while engaging the accelerator pedal with the EPB applied, but the EPB doesn't release automatically, a warning will sound and a message will appear.
- If the driver's seat belt is not fastened and the vehicle hood, driver's door or trunk is opened, a warning will sound and a message will appear.
- If there is a problem with the vehicle, a warning may sound and a message may appear.

If the situation occurs, press the brake pedal and release EPB by pressing the EPB switch.

⚠ WARNING

- Whenever leaving the vehicle or parking, always come to a complete stop and continue to depress the brake pedal. Shift the gear into P (Park), pull the EPB switch, and press the ENGINE START/STOP button to the OFF position. Take the key with you when leaving the vehicle. Vehicles not fully engaged in P (Park) with the parking brake set are at risk

for moving inadvertently and causing injury to yourself or others.

- Never allow a passenger to touch the parking brake. If the parking brake is released unintentionally, serious injury may occur.
- Only release EPB when you are seated inside the vehicle with your foot firmly on the brake pedal.

* NOTICE

- Do not apply the accelerator pedal while the parking brake is engaged. If you depress the accelerator pedal with EPB engaged, a warning will sound and a message will appear. Damage to the parking brake may occur.
- Driving with the parking brake on can overheat the braking system and cause premature wear or damage to brake parts. Make sure EPB is released and the Parking Brake warning light is off before driving.

* NOTICE

- A click or electric brake motor whine sound may be heard while operating or releasing the EPB. These conditions are normal and indicate that the EPB is functioning properly.
- When leaving your keys with a parking lot attendant or valet, make sure to inform him/her how to operate the EPB.

AUTO HOLD turning Off! Press brake pedal

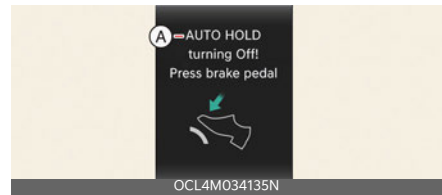

A: AUTO HOLD turning Off! Press brake pedal

When the conversion from AUTO HOLD to EPB is not working properly a warning will sound and a message will appear.

Parking brake automatically engaged

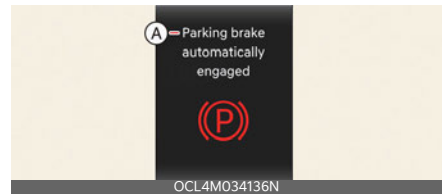

A: Parking brake automatically engaged

When EPB is applied while AUTO HOLD is activated or when the driver door is opened while the engine is running, a warning will sound and a message will appear.

EPB malfunction

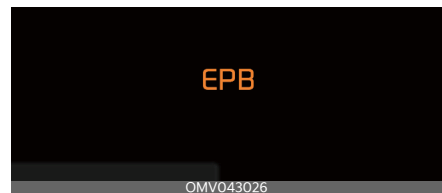

This warning light illuminates if the ENGINE START/STOP button is changed to the ON position and turns off in

approximately 3 seconds if the system is operating normally.

If the EPB malfunction indicator remains on, comes on while driving, or does not come on when the ENGINE START/ STOP button is changed to the ON position, this indicates that the EPB may have malfunctioned.

Have your vehicle checked by an authorized Kia dealer.

The EPB malfunction indicator may illuminate when the ESC indicator comes on to indicate that the ESC is not working properly, but it does not indicate a malfunction of the EPB.

*** NOTICE**

- If the EPB warning light is still on, have the system checked by an authorized Kia dealer.
- If the parking brake warning light does not illuminate or blinks even though the EPB switch was pulled up, the EPB is not applied.
- If the parking brake warning light blinks when the EPB warning light is on, press the EPB switch, then pull it up. Press it back to its original position and pull it back up. If the EPB warning does not turn off, have the system checked by an authorized Kia dealer.

When the EPB is not released

If the EPB does not release normally, take your vehicle to an authorized Kia dealer by loading the vehicle on a flat-bed tow truck and have the system checked. Visit an authorized Kia dealer.

AUTO HOLD

AUTO HOLD is designed to maintain the vehicle in a standstill even though the brake pedal is not pressed after you bring the vehicle to a complete stop by pressing the brake pedal.

Applying AUTO HOLD function

1. Press the brake pedal and start the vehicle.
2. Press the AUTO HOLD button. The white AUTO HOLD indicator will come on indicating the system is in standby.

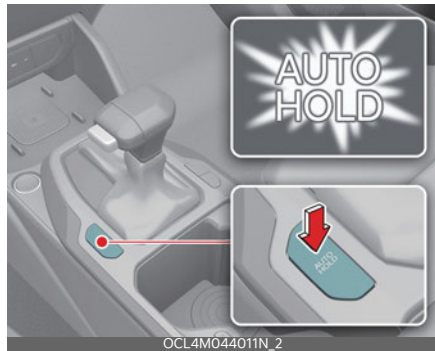

Before the AUTO HOLD will engage, the driver's door and engine hood must be closed.

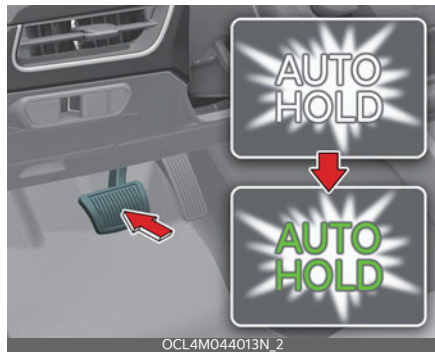

When coming to a complete stop by pressing the brake pedal, the AUTO HOLD indicator changes from white to

green indicating the AUTO HOLD is engaged. The vehicle will remain at a standstill even if you release the brake pedal.

If EPB is applied, AUTO HOLD will be released.

If you press the accelerator pedal with the shift lever in D (Drive) or Manual mode, the AUTO HOLD will be released automatically and the vehicle will start to move. The indicator changes from green to white indicating the AUTO HOLD is in standby and the EPB is released.

When driving off from AUTO HOLD by pressing the accelerator pedal, always check your surroundings.

Slowly press the accelerator pedal for a smooth launch.

Canceling AUTO HOLD function

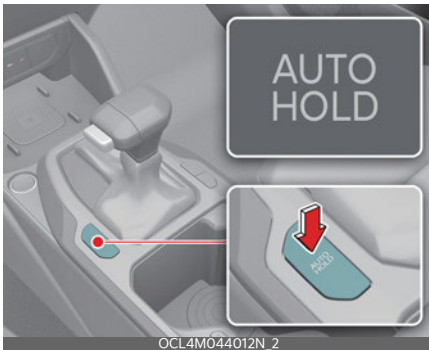

- To cancel the AUTO HOLD operation, press the AUTO HOLD switch. The AUTO HOLD indicator will turn off.
- To cancel the AUTO HOLD operation when the vehicle is at a standstill, press the AUTO HOLD switch while pressing the brake pedal.

* NOTICE

- The following are conditions when the Auto Hold will not engage (Auto Hold

light will not turn green and the Auto Hold system remains in standby):

- The shift lever is in P (Park) or R (Reverse)
- The EPB is applied
- For your safety, the AUTO HOLD automatically switches to EPB under any of the following conditions (AUTO HOLD light remains white and the EPB automatically applies):
 - The driver's door is opened.
 - The engine hood is opened.
 - The vehicle is in a standstill for more than 10 minutes.
 - The vehicle is standing on a steep slope.
 - The vehicle moved for a few seconds.

In these cases, the brake warning light comes on, the AUTO HOLD indicator changes from green to white, a warning sounds and a message will appear to inform you that EPB has been automatically engaged. Before driving again, press the brake pedal, check the surrounding area near your vehicle and release parking brake manually with the EPB switch.

- When the AUTO HOLD operation button is pressed and the ignition is turned off and then restarted, AUTO HOLD remains in a standby state.
- If the AUTO HOLD indicator lights up yellow, the AUTO HOLD is not working properly. Take your vehicle to an authorized Kia dealer and have the system checked.

⚠ WARNING

To reduce the risk of an accident, do not activate AUTO HOLD while driving

downhill, backing up or parking your vehicle.

If there is a malfunction with the driver's door or engine hood open detection system, the AUTO HOLD may not work properly.

Take your vehicle to an authorized Kia dealer and have the system checked.

*** NOTICE**

A click or electric brake motor whine sound may be heard while operating or releasing the EPB. These conditions are normal and indicate that the EPB is functioning properly.

Warning messages

The AUTO HOLD function will display a warning message with sound under certain conditions:

When the EPB is applied from AUTO HOLD, a warning will sound and a message will appear.

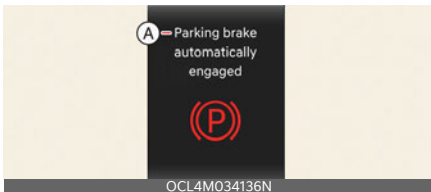

A: Parking brake automatically engaged

When the conversion from AUTO HOLD to EPB is not working properly a warning will sound and a message will appear.

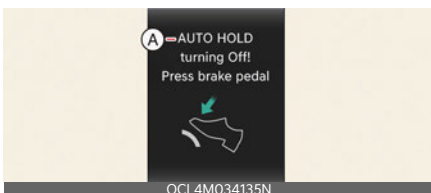

A: AUTO HOLD turning Off! Press brake pedal

*** NOTICE**

When this message is displayed, the AUTO HOLD and EPB may not operate. For your safety, press the brake pedal.

If you do not apply the brake pedal when you release the AUTO HOLD by pressing the [AUTO HOLD] switch, a warning will sound and a message will appear.

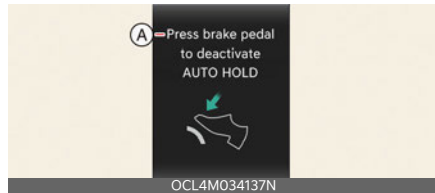

A: Press brake pedal to deactivate AUTO HOLD

When you press the [AUTO HOLD] switch if the driver does not press the brake pedal, a warning will sound and a message will appear on the LCD display.

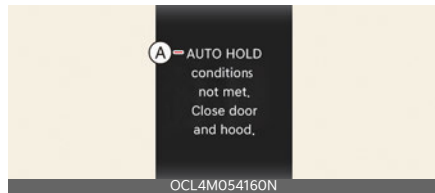

A: AUTO HOLD conditions not met. Close door and hood.

Press the [AUTO HOLD] button after closing the driver's door and engine hood.

Anti-lock Brake System (ABS)

The Anti-lock Brake System (ABS) prevents the wheels from locking so the vehicle remains stable and can still be steered.

ABS (or ESC) will not prevent accidents due to improper or dangerous driving maneuvers. Even though vehicle control is improved during emergency braking, always maintain a safe distance between you and objects ahead. Vehicle speeds should always be reduced during extreme road conditions. Drive your vehicle at reduced speeds under the following circumstances:

- When driving on rough, gravel or snow-covered roads
- When driving on roads where the road surface is pitted or has different surface heights.

Driving in these conditions increases the stopping distance for your vehicle.

The ABS continuously senses the speed of the wheels. If the wheels are going to lock, the ABS repeatedly modulates the hydraulic brake pressure to the wheels.

When you apply your brakes under conditions which may lock the wheels, you may hear a "tik-tik" sound from the brakes or feel a corresponding sensation in the brake pedal. This is normal and it means your ABS is active.

To obtain the maximum benefit from your ABS in an emergency situation, do not attempt to modulate your brake pressure and do not try to pump your brakes. Press your brake pedal as hard as possible to allow the ABS to control the force being delivered to the brakes.

* NOTICE

A click sound may be heard in the engine compartment when the vehicle begins to move after the vehicle is started. These conditions are normal and indicate that the Anti-lock Brake System is functioning properly.

Even with the ABS, your vehicle still requires sufficient stopping distance. Always maintain a safe distance from a vehicle ahead.

Always slow down when cornering. The ABS cannot prevent accidents resulting from excessive speeds.

On loose or uneven road surfaces, operation of the ABS may result in a longer stopping distance than for vehicles equipped with a conventional brake system.

The ABS warning light will stay on for approximately 3 seconds after the ENGINE START/STOP button is ON.



During that time, the ABS will go through self-diagnosis and the light will turn off if everything is normal. If the light stays on, you may have a problem with your ABS. Contact an authorized Kia dealer as soon as possible.

When you drive on a road having poor traction, such as an icy road, and have operated your brakes continuously, the ABS will be active continuously and the ABS warning light may appear. Pull your vehicle over to a safe place and stop the vehicle.

Restart the vehicle. If the ABS warning light goes off, then your ABS is normal. Otherwise, you may have a problem with the ABS. Contact an authorized Kia dealer as soon as possible.

* NOTICE

When you jump start your vehicle because of a drained battery, the vehicle may not run as smoothly and the ABS warning light may turn on at the same

time. This happens because of low battery voltage. It does not mean the ABS has malfunctioned.

- Do not pump your brakes.
- Have the battery recharged before driving the vehicle.

Electronic Stability Control (ESC) system

The ESC is designed to stabilize the vehicle during cornering maneuvers.

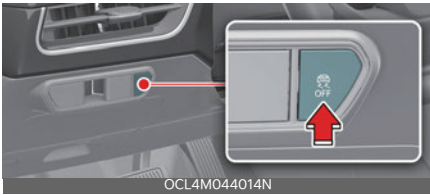

ESC applies the brakes on individual wheels and intervenes with the vehicle management system to stabilize the vehicle.

ESC will not prevent accidents. Excessive speed in turns, abrupt maneuvers and hydroplaning on wet surfaces can still result in serious accidents.

Only a safe and attentive driver can prevent accidents by avoiding maneuvers that cause the vehicle to lose traction. Even with ESC installed, always follow all the normal precautions for driving - including driving at safe speeds for the conditions.

⚠ WARNING

For maximum protection, always wear your seat belt. No system, no matter how advanced, can compensate for all driver error and/or driving conditions. Always drive responsibly.

The ESC system is an electronic system designed to help the driver maintain

vehicle control under adverse conditions. It is not a substitute for safe driving practices. Factors including speed, road conditions and driver steering input can all affect whether ESC will be effective in preventing a loss of control. It is still your responsibility to drive and corner at reasonable speeds and to leave a sufficient margin of safety.

When you apply your brakes under conditions which may lock the wheels, you may hear a "tik-tik" sound from the brakes or feel a corresponding sensation in the brake pedal. This is normal and it means your ESC is active.

*** NOTICE**

A click sound may be heard in the vehicle compartment when the vehicle begins to move after the vehicle is started. These conditions are normal and indicate that the ESC system is functioning properly.

ESC operation

ESC ON condition

- When the ENGINE START/STOP button is turned ON, ESC and ESC OFF indicator lights appear for approximately 3 seconds, then ESC is turned on.
- Press the ESC OFF button for at least half a second after turning the vehicle ON to turn ESC off. (ESC OFF indicator will appear). To turn the ESC on, press the ESC OFF button (ESC OFF indicator light will go off).
- When starting the vehicle, you may hear a slight ticking sound. This is the ESC performing an automatic system

self-check and does not indicate a problem.

When operating



When the ESC is in operation, the ESC indicator light blinks.

When the ESC is operating properly, you can feel a slight pulsation in the vehicle. This is normal.

When moving out of the mud or driving on a slippery road, pressing the accelerator pedal may not cause the vehicle rpm (revolutions per minute) to increase.

ESC operation off





This car has 2 kinds of ESC off states.

If the vehicle stops when ESC is off, ESC remains off. Upon restarting the vehicle, the ESC will automatically turn on.



A: Traction and Stability Control disabled

ESC off state 1

To turn off the traction control function and only operate the brake control function of the ESC, press the ESC OFF button "ESC OFF  for less than 3 seconds and the ESC OFF indicator light "ESC OFF  will appear.

ESC off state 2

To turn off the traction control function and the brake control function of the ESC, press the ESC OFF button "ESC

OFF  for more than 3 seconds. ESC

OFF indicator light "ESC OFF  will appear and ESC OFF warning chime will sound. At this state, the car stability control function does not operate anymore.

Indicator light

ESC indicator light



ESC OFF indicator light



When ENGINE START/STOP button is turned on, the indicator light appears, then turns off if the ESC system is operating normally.

The ESC indicator light blinks whenever ESC is operating or appears when ESC fails to operate.

The ESC OFF indicator light turns on when the ESC is turned off with the button.

WARNING

Electronic Stability Control

Drive carefully even though your vehicle has Electronic Stability Control. It can only assist you in maintaining control under certain circumstances.

ESC OFF usage

When driving

- ESC should be turned on for daily driving whenever possible.
- To turn ESC off while driving, press the ESC OFF button while driving on a flat road surface.

WARNING

Operating ESC

Never press the ESC OFF button while ESC is operating (ESC indicator light blinks).

If ESC is turned off while ESC is operating, the vehicle may slip out of control.

NOTICE

- When operating your vehicle on a dynamometer, ensure that the ESC is turned off (ESC OFF light appeared). If the ESC is left on, it may prevent the vehicle speed from increasing, and result in false diagnosis.
- Turning the ESC off does not affect ABS or brake system operation.

Vehicle Stability Management (VSM) system

The VSM provides further enhancements to vehicle stability and steering responses under the following condition:

- when driving on a slippery road or
- when a change in the coefficient of friction between left and right wheels is detected.

WARNING

Tire/wheel size

When replacing tires and wheels, make sure they are the same size as the original tires and wheels installed. Driving

with varying tire or wheel sizes may diminish any supplemental safety benefits of the VSM system.

VSM operation

When the VSM is operating properly, you can feel a slight pulsation in the vehicle and/or abnormal steering responses (Motor Driven Power Steering (MDPS)). This is only the effect of brake and MDPS control and indicates nothing unusual.

The VSM does not operate when:

- Driving on a sloping road such as a gradient or incline
- Driving in reverse
- ESC OFF indicator light  remains on the instrument cluster
- MDPS indicator light remains on the instrument cluster

VSM operation off

If you press the ESC OFF button to turn off the ESC, the VSM will also cancel and the ESC OFF indicator light  appears.



To turn on the VSM, press the button again. The ESC OFF indicator light goes out.

WARNING

Vehicle Stability Management

Drive carefully even though your vehicle has VSM. It can only assist you in maintaining control of the vehicle under certain circumstances.

Malfunction indicator

The VSM can be deactivated even if you don't cancel the VSM operation by pressing the ESC OFF button. It indicates that a malfunction has been detected somewhere in the Motor Driven Power Steering system or VSM system. If the ESC indicator light  or MDPS warning light  remains on, take your vehicle to an authorized Kia dealer and have the system checked.

The VSM is not a substitute for safe driving practices but is only a supplementary function. It is your responsibility to always check the speed and the distance to the vehicle ahead. Always hold the steering wheel firmly while driving.

Your vehicle is designed to activate according to the driver's intention, even with installed VSM. Always follow all the normal precautions for driving at safe speeds for the conditions - including driving in inclement weather or on a slippery road.

WARNING

For maximum protection, always wear your seat belt. No system, no matter how advanced, can compensate for all driver error and/or driving conditions. Always drive responsibly.

Hill-start Assist Control (HAC)

A vehicle has the tendency to roll back on a steep hill when it starts to go after stopping. The HAC prevents the vehicle from rolling back by applying the brakes automatically for about 2 seconds.

The brakes are released when the accelerator pedal is engaged or after about 2 seconds.

The HAC is activated only for about 2 seconds, so when the vehicle is starting off always engage the accelerator pedal.

WARNING

Maintaining Brake Pressure on Incline

HAC does not replace the need to apply brakes while stopped on an incline.

While stopped, make sure you maintain sufficient brake pressure to prevent your vehicle from rolling backward and causing an accident. Don't release the brake pedal until you are ready to accelerate.

Good braking practices

Good braking practices help keep occupants safe and extend brake life.

- Check to be sure the parking brake is not engaged and the parking brake indicator light is off before driving.
- Driving through water may wet the brakes. They can also get wet when the vehicle is washed. Wet brakes can be dangerous. Your vehicle will not stop as quickly if the brakes are wet. Wet brakes may cause the vehicle to pull to one side.

To dry the brakes, apply the brakes lightly until the braking action returns to normal, taking care to always keep the vehicle under control. If the braking action does not return to normal, stop as soon as it is safe to do so and call an authorized Kia dealer for assistance.

- Don't coast down hills with the vehicle out of gear. This is extremely hazardous. Always keep the vehicle in gear, use the brakes to slow down, then shift to a lower gear so that vehicle braking will help you maintain a safe speed.

- Don't "ride" the brake pedal. Resting your foot on the brake pedal while driving can be dangerous because the brakes might overheat and lose its effectiveness. It also increases the wear of the brake components.
- If a tire goes flat while you are driving, apply the brakes gently and keep the vehicle pointed straight ahead while you slow down. When you are moving slowly enough for it to be safe to do so, pull off the road and stop in a safe place.
- Be cautious when parking on a hill. Firmly engage the parking brake and place the shift lever in P (Park). If your vehicle is facing downhill, turn the front wheels into the curb to help keep the vehicle from rolling. If your vehicle is facing uphill, turn the front wheels away from the curb to help keep the vehicle from rolling. If there is no curb or if it is required by other conditions to keep the vehicle from rolling, block the wheels.
- Under some conditions your parking brake can freeze in the engaged position. This is most likely to happen when there is an accumulation of snow or ice around the rear brakes or if the brakes are wet. If there is a risk that the parking brake may freeze, apply it only temporarily while you put the shift lever in P (Park) and block the rear wheels so the vehicle cannot roll. Then release the parking brake.
- Do not hold the vehicle on an incline with the accelerator pedal. This can cause the transmission to overheat. Always use the brake pedal or parking brake.

Vehicle Auto Shut-off system

The vehicle auto shut-off system is designed to automatically shut off the vehicle after a certain time the driver sets to reduce fuel consumption and energy consumption of the vehicle and to prevent carbon monoxide (CO) poisoning.

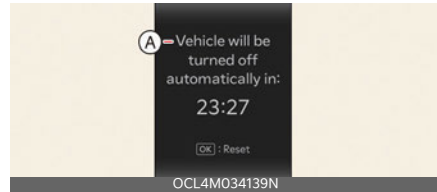

A: Vehicle will be turned off automatically in:

Requirements for activation

This system can be activated when the following all requirements are satisfied.

- The ignition switch is ON.
- The transmission is in the P (Park) position.
- The vehicle stops.
- The vehicle speed is under 3 km/h (2 mph).
- The driver's seat belt is unfastened.
- The door is opened.
- The passenger's seat is not occupied.

* NOTICE

- The default setting will be retained until the timer is reset.
- The default setting is 30 minutes.

Resetting the time

The system can be initialized and restarted under the following conditions:

- When pressing and releasing the brake pedal.

- When the accelerator pedal is depressed.
- When the driver manually resets the timer.
- When the driver manually presses the OK button on the steering wheel.

Canceling the Vehicle Auto Shut-off system

The system will be canceled automatically when:

- The vehicle speed is over 3 km/h (2 mph).
- The vehicle is shifted to D (Drive), R (Reverse) or N (Neutral).
- The driver's seat belt is fastened.

Drive mode integrated control system

Drive mode

The drive mode may be selected according to the driver's preference or road condition.



The mode changes when you press the drive mode button.

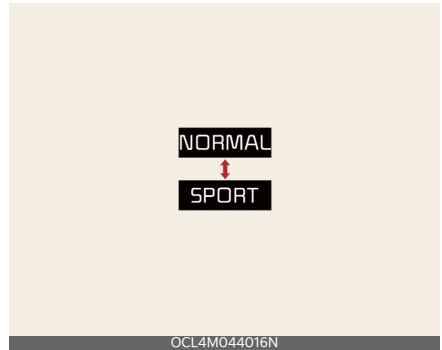

- **NORMAL mode:**
NORMAL mode provides soft driving and comfortable riding.
- **SPORT mode:**
SPORT mode provides sporty but firm riding.

The drive mode will change to NORMAL mode when the engine is restarted.

When changing the drive mode setting, the responsiveness of Smart Cruise Control changes. (If equipped)

Drive Mode	SCC Responsiveness
NORMAL	Normal
SPORT	Fast

SPORT mode

SPORT SPORT mode manages the driving dynamics by automatically adjusting the steering effort, the engine and transmission control logic for enhanced driver performance.

- Whenever the engine is restarted, the drive mode sets to NORMAL mode.
- When SPORT mode is activated:
 - The engine rpm will tend to remain raised over a certain length of time even after releasing the accelerator
 - Upshifts are delayed when accelerating

* NOTICE

In SPORT mode, the fuel efficiency may decrease.

Economical operation

Your vehicle's fuel economy depends mainly on your style of driving, where you drive and when you drive.

Each of these factors affects how many kilometers (miles) you can get from a liter (gallon) of fuel. To operate your vehicle as economically as possible, use the following driving suggestions to help save money in both fuel and repairs:

- Drive smoothly. Accelerate at a moderate rate. Don't make "jackrabbit" starts or full-throttle shifts and maintain a steady cruising speed. Don't race between stoplights. Try to adjust your speed to the traffic so you don't have to change speeds unnecessarily. Avoid heavy traffic whenever possible.

Always maintain a safe distance from other vehicles so you can avoid unnecessary braking. This also reduces brake wear.

- Drive at a moderate speed. The faster you drive, the more fuel your vehicle uses. Driving at a moderate speed, especially on the highway, is one of the most effective ways to reduce fuel consumption.
- Take care of your tires. Keep them inflated to the recommended pressure. Incorrect inflation, either too much or too little, results in unnecessary tire wear. Check the tire pressures at least once a month.
- Be sure that the wheels are aligned correctly. Improper alignment can result from hitting curbs or driving too fast over irregular surfaces. Poor alignment causes faster tire wear and may also result in other problems as well as greater fuel consumption.

- Keep your car in good condition. For better fuel economy and reduced maintenance costs, maintain your car in accordance with the maintenance schedule in "Scheduled maintenance service" on page 8-8. If you drive your car in severe conditions, more frequent maintenance is required (Refer to "Maintenance Under Severe Usage Conditions" on page 8-11 for details).
- Travel lightly. Don't carry unnecessary weight in your car. Weight reduces fuel economy.
- Don't let the engine idle longer than necessary. If you are waiting (and not in traffic), turn off your engine and restart only when you're ready to go.
- Don't "lug" or "over-rev" the engine. Lugging is driving too slowly in too high a gear resulting in the engine bucking. If this happens, shift to a lower gear. Over-revving is racing the engine beyond its safe limit. This can be avoided by shifting at the recommended speeds.
- Open windows at high speeds can reduce fuel economy.
- Fuel economy is less in crosswinds and headwinds. To help offset some of this loss, slow down when driving in these conditions.

Keeping a vehicle in good operating condition is important both for economy and safety.

Therefore, have an authorized Kia dealer perform scheduled inspections and maintenance.

WARNING

Engine off during motion

Never turn the engine off to coast down hills or anytime the vehicle is in motion. The power steering and power brakes

will not function properly without the engine running. In addition, turning off the ignition while driving could engage the steering wheel lock resulting in loss of vehicle steering. Keep the engine on and downshift to an appropriate gear for engine braking effect.

Special driving conditions

If driving conditions deteriorate due to poor weather or road conditions, you should pay even more attention than usual to your driving.

Hazardous driving conditions

When hazardous driving conditions are encountered such as water, snow, ice, mud, sand, or similar hazards, follow these suggestions:

- Drive cautiously and allow extra distance for braking.
- Avoid sudden braking or steering.
- Do not pump the brake pedal on a vehicle equipped with ABS.
- If stalled in snow, mud, or sand, use the second gear. Accelerate slowly to avoid spinning the drive wheels.
- Use sand, rock salt or other nonslip material under the drive wheels to provide traction when stalled in ice, snow, or mud.

Rocking the vehicle

If it is necessary to rock the vehicle to free it from snow, ice, sand, or mud, first turn the steering wheel right and left to clear the area around your driven wheels. Shift back and forth between R (Reverse) and any forward gear.

Do not race the engine and spin the wheels as little as possible. If you are still stuck after a few tries, have the vehicle pulled out by a tow vehicle to avoid engine overheating and possible damage to the transmission.

WARNING

Sudden Vehicle Movement

Do not attempt to rock the vehicle if people or objects are nearby. The vehi-

cle may suddenly move forward or backwards as it becomes unstuck.

CAUTION

Vehicle rocking

Prolonged rocking may cause vehicle overheating, transmission damage or failure, and tire damage.

CAUTION

Spinning tires

Do not spin the wheels, especially at speeds more than 56 km/h (35 mph). Spinning the wheels at high speeds when the vehicle is stationary could overheat and damage tires, and the rotating wheels may fly away and injure bystanders.

NOTICE

*The ESC should be turned OFF prior to rocking the vehicle.

Smooth cornering

Avoid braking or gear changing in corners, especially when roads are wet. Ideally, corners should always be taken under gentle acceleration. If you follow these suggestions, tire wear will be minimized.

Driving at night

Because night driving presents more hazards than driving in the daylight, here are some important tips to remember:

- Slow down and keep more distance between you and other vehicles, as it may be more difficult to see at night,

especially in areas where there may not be any streetlights.

- Adjust your mirrors to reduce the glare from other driver's headlights.
- Keep your headlights clean and properly aimed on vehicles not equipped with the automatic headlight aiming feature. Dirty or improperly aimed headlights will make it much more difficult to see at night.
- Avoid staring directly at the headlights of oncoming vehicles. You could be temporarily blinded, and it will take several seconds for your eyes to readjust to the darkness.

Driving in the rain

Rain and wet roads can make driving dangerous, especially if you're not prepared for the slick pavement.

A few things to consider when driving in the rain:

- A heavy rainfall will make it harder to see and will increase the distance needed to stop your vehicle, so slow down.
- Keep your windshield wiping equipment in good shape. Replace your windshield wiper blades when they show signs of streaking or missing areas on the windshield.
- If your tires are not in good condition, making a quick stop on wet pavement can cause a skid and possibly lead to an accident. Be sure your tires are in good shape.
- Turn on your headlights to make it easier for others to see you.
- Driving too fast through large puddles can affect your brakes. If you must go through puddles, drive through them slowly.

- If you believe your brakes are wet, apply them lightly while driving until normal braking operation returns.

Hydroplaning

If the road is wet enough and you are going fast enough, your vehicle may have little or no contact with the road surface and ride on the water. The best advice is SLOW DOWN when the road is wet.

The risk of hydroplaning increases as the depth of tire tread decreases, refer to "Tire replacement" on page 8-31.

Driving in flooded areas

Avoid driving through flooded areas unless you are sure the water is no higher than the bottom of the wheel hub. Drive through any water slowly. Allow adequate stopping distance because brake performance may be affected.

After driving through water, dry the brakes by gently applying them several times while the vehicle is moving slowly.

Highway driving

Tires

Adjust the tire inflation pressures to specification. Low tire inflation pressures will result in overheating and possible failure of the tires.

Avoid using worn or damaged tires which may result in reduced traction or tire failure.

Never exceed the maximum tire inflation pressure shown on the tires.

⚠ WARNING**Under/over inflated tires**

Always check the tires for proper inflation before driving. Underinflated or overinflated tires can cause poor handling, loss of vehicle control, and sudden tire failure, leading to accidents, injuries, and even death. For proper tire pressures, refer to "Tires and wheels" on page 8-29.

⚠ WARNING**Tire tread**

Always check the tire tread before driving your vehicle. Worn-out tires can result in loss of vehicle control. Worn-out tires should be replaced as soon as possible. For further information and tread limits, refer to "Tires and wheels" on page 8-29.

Fuel, engine coolant and engine oil

High speed travel consumes more fuel than urban driving. Check both the engine coolant and engine oil.

Drive belt

A loose or damaged drive belt may result in overheating of the engine.

Winter driving

Severe weather conditions in the winter result in greater tire wear and other problems.

To minimize the problems of winter driving, follow these suggestions:

Snowy or icy conditions

To drive your vehicle in deep snow, it may be necessary to use snow tires on your tires.

If snow tires are needed, select tires equivalent in size and type of the original equipment tires. Furthermore, speeding, rapid acceleration, sudden brake applications and sharp turns are potentially very hazardous practices. Failure to do so may adversely affect the safety and handling of your vehicle. Furthermore, speeding, rapid acceleration, sudden brake applications, and sharp turns are potentially very hazardous practices.

During deceleration, use full vehicle braking. Keep sufficient distance between the vehicle in operation in front of your vehicle. Apply the brake gently. Sudden brake applications on snowy or icy roads may cause skids to occur. You need to keep sufficient distance between the vehicle in operation in front of your vehicle. Also, apply the brake gently. Installing tire chains on the tire will provide a greater driving force, but will not prevent side skids.

Snow tires

If you mount snow tires on your vehicle, make sure they are radial tires of the same size and load range as the original tires. Mount snow tires on all four wheels to balance your vehicle's handling in all weather conditions. The traction pro-

vided by snow tires on dry roads may not be as high as your vehicle's original equipment tires. You should drive cautiously even when the roads are clear. Check with the tire dealer for maximum speed recommendations.

Do not install studded tires without first checking local, state and municipal regulations for possible restrictions against their use.

WARNING

Snow tire size

Snow tires should be equivalent in size and type to the vehicle's standard tires. Otherwise, the safety and handling of your vehicle may be adversely affected.

Use high quality ethylene glycol coolant

Your vehicle is delivered with high quality ethylene glycol coolant. It is the only type of coolant that should be used because it helps prevent corrosion in the cooling system, lubricates the water pump and prevents freezing. Be sure to replace or replenish your coolant refer to "Normal maintenance schedule" on page 8-9. Before winter, have your coolant tested to assure that its freezing point is sufficient for the temperatures anticipated during the winter.

Check battery and cables

Winter puts additional burdens on the battery system. Visually inspect the battery and cables (refer to "For best battery service" on page 8-26). The level of charge in your battery can be checked by an authorized Kia dealer or a service station.

Change to "winter weight" oil if necessary

In some climates it is recommended that a lower viscosity "winter weight" oil be used during cold weather. Refer to "Recommended lubricants and capacities" on page 9-9 for recommendations. If you aren't sure what weight oil you should use, consult an authorized Kia dealer.

Check spark plugs and ignition system

Inspect your spark plugs as described in "Scheduled maintenance service" on page 8-8 and replace them if necessary. Check all ignition wiring and components to be sure they are not cracked, worn or damaged in any way.

To keep locks from freezing

To keep the locks from freezing, squirt an approved deicer fluid or glycerine into the key opening. If a lock is covered with ice, squirt it with an approved de-icing fluid to remove the ice. If the lock is frozen internally, you may be able to thaw it out by using a heated key. Handle the heated key with care to avoid injury.

Use approved window washer anti-freeze in system

To keep the water in the window washer system from freezing, add an approved window washer anti-freeze solution in accordance with instructions on the container. Window washer anti-freeze is available from an authorized Kia dealer and most auto parts outlets. Do not use vehicle coolant or other types of anti-freeze as these may damage the paint finish.

Don't let your parking brake freeze

Under some conditions your parking brake can freeze in the engaged position. This is most likely to happen when there is an accumulation of snow or ice around the rear brakes or if the brakes are wet. If there is a risk the parking brake may freeze, apply it only temporarily while you put the shift lever in P (Park) and block the rear wheels so the vehicle cannot roll. Then release the parking brake.

Don't let ice and snow accumulate underneath

Under some conditions, snow and ice can build up under the fenders and interfere with the steering. In severe winter conditions you should periodically check underneath the vehicle to be sure the movement of the front wheels and the steering components are not obstructed.

Carry emergency equipment

Depending on the severity of the weather, carry appropriate emergency equipment. Some items you may want to carry include tow straps or chains, flashlight, emergency flares, sand, shovel, jumper cables, window scraper, gloves, ground cloth, coveralls, blanket, etc.

Do not place objects or materials in the engine compartment

Putting objects or materials in the engine compartment may cause an engine failure or combustion, because they may block the engine cooling. Such damage will not be covered by your warranty.

Drive your vehicle when water vapor condenses and accumulates inside the exhaust pipes

When the vehicle is stopped for a long time in winter while the engine is running, water vapor may condense and accumulate inside the exhaust pipes. Water in the exhaust pipes may cause noise, etc., but is drained driving at medium to high speed.

Trailer towing

We do not recommend using this vehicle for trailer towing.

Vehicle load limit

The vehicle load limit is displayed on the tire and loading information label on the driver's door.

Tire and loading information label

The label located on the driver's door sill gives the original tire size, cold tire pressures recommended for your vehicle, the number of people that can be in your vehicle and vehicle capacity weight.

Example for tire pressure label



Vehicle capacity weight:

410 kg (904 lbs.)

Vehicle capacity weight is the maximum combined weight of occupants and cargo. If your vehicle is equipped with a trailer, the combined weight includes the tongue load.

Seating capacity:

Total: 5 persons (Front seat: 2 persons, Rear seat: 3 persons)

Seating capacity is the maximum number of occupants including a driver, your vehicle may carry.

However, the seating capacity may be reduced based upon the weight of all the occupants, and the weight of the cargo being carried or towed.

Do not overload the vehicle as there is a limit to the total weight, or load limit

including occupants and cargo, the vehicle can carry.

Towing capacity:

We do not recommend using this vehicle for trailer towing.

Cargo capacity:

The cargo capacity of your vehicle will increase or decrease depending on the weight and the number of occupants.

Steps For Determining Correct Load Limit —

1. Locate the statement "The combined weight of occupants and cargo should never exceed XXX kg or XXX lbs." on your vehicle's placard.
2. Determine the combined weight of the driver and passengers that will be riding in your vehicle.
3. Subtract the combined weight of the driver and passengers from XXX kg or XXX lbs.
4. The resulting figure equals the available amount of cargo and luggage load capacity. For example, if the "XXX" amount equals 635 kg (1400 lbs.) and there will be five 68 kg (150 lbs.) passengers in your vehicle, the amount of available cargo and luggage load capacity is 295 kg (650 lbs.). (635-340 (5 x 68) = 295 kg or 1400-750 (5 x 150) = 650 lbs.)
5. Determine the combined weight of luggage and cargo being loaded on the vehicle. That weight may not safely exceed the available cargo and luggage load capacity calculated in Step 4.
6. If your vehicle will be towing a trailer, load from your trailer will be transferred to your vehicle. Consult this

manual to determine how this reduces the available cargo and luggage load capacity of your vehicle.

⚠ WARNING

Loose cargo

Do not travel with unsecured blunt objects in the passenger compartment of your vehicle (e.g., suitcases or unsecured child seats). These items may strike occupant during a sudden stop or crash.

Example 1

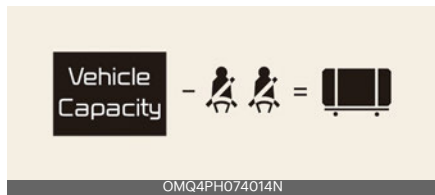

Item	Description	Total
A	Vehicle Capacity Weight	385 kg (849 lbs.)
B	Subtract Occupant Weight 68 kg (150 lbs.)x2	136 kg (300 lbs.)
C	Available Cargo and Luggage weight	249 kg (549 lbs.)

Example 2

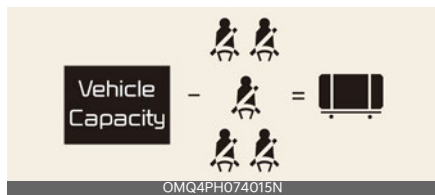

Item	Description	Total
A	Vehicle Capacity Weight	385 kg (849 lbs.)

Item	Description	Total
B	Subtract Occupant Weight 68 kg (150 lbs.)x5	340 kg (750 lbs.)
C	Available Cargo and Luggage weight	45 kg (99 lbs.)

Example 3

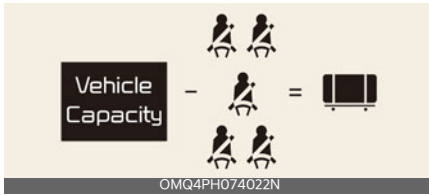

Item	Description	Total
A	Vehicle Capacity Weight	385 kg (849 lbs.)
B	Subtract Occupant Weight 73 kg (161 lbs.)x5	365 kg (805 lbs.)
C	Available Cargo and Luggage weight	44 kg (20 lbs.)

Refer to your vehicle's tire and loading information label for specific information about your vehicle's capacity weight and seating positions. The combined weight of the driver, passengers and cargo should never exceed your vehicle's capacity weight.

Certification label

The certification label is located on the driver's door sill at the center pillar.

This label shows the maximum allowable weight of the fully loaded vehicle. This is called the GVWR (Gross Vehicle Weight Rating). The GVWR includes the weight of the vehicle, all occupants and cargo.

This label also tells you the maximum weight that can be supported by the

front and rear axles, called Gross Axle Weight Rating (GAWR).

To find out the actual loads on your front and rear axles, you need to go to a weigh station and weigh your vehicle. Your dealer can help you with this. Be sure to spread out your load equally on both sides of the centerline.

⚠ WARNING

Over loading

Never exceed the GVWR for your vehicle, the GAWR for either the front or rear axle and vehicle capacity weight. Exceeding these ratings can affect your vehicle's handling and braking ability.

The label will help you decide how much cargo and installed equipment your vehicle can carry.

If you carry items inside your vehicle - like suitcases, tools, packages, or anything else - they are moving as fast as the vehicle. If you must stop or turn quickly, or if there is a crash, the items will keep going and can cause an injury if they strike the driver or a passenger.

⚠ WARNING

Over loading

Do not overload your vehicle. Overloading your vehicle can cause heat buildup in your vehicle's tires and possible tire failure, increased stopping distances and poor vehicle handling--all of which may result in a crash.

*** NOTICE**

Overloading your vehicle may cause damage. Repairs would not be covered by your warranty. Do not overload your vehicle.

Vehicle weight

This section will guide you in the proper loading of your vehicle to keep your loaded vehicle weight within its design rating capability, with or without a trailer.

Properly loading your vehicle will provide maximum return of the vehicle design performance. Before loading your vehicle, familiarize yourself with the following terms for determining your vehicle's weight ratings, with or without a trailer, from the vehicle's specifications and the compliance label:

Base curb weight

This is the weight of the vehicle including a full tank of fuel and all standard equipment. It does not include passengers, cargo, or optional equipment.

Vehicle curb weight

This is the weight of your new vehicle when you picked it up from your dealer plus any aftermarket equipment.

Cargo weight

This figure includes all weight added to the Base Curb Weight, including cargo and optional equipment.

GAW (Gross Axle Weight)

This is the total weight placed on each axle (front and rear) - including vehicle curb weight and all payload.

GAWR (Gross Axle Weight Rating)

This is the maximum allowable weight that can be carried by a single axle (front or rear). These numbers are shown on the compliance label. The total load on each axle must never exceed its GAWR.

GVW (Gross Vehicle Weight)

This is the Base Curb Weight plus actual Cargo Weight plus passengers.

GVWR (Gross Vehicle Weight Rating)

This is the maximum allowable weight of the fully loaded vehicle (including all

options, equipment, passengers and cargo). The GVWR is shown on the certification label located on the driver's door sill.

CAUTION

Do not use replacement tires with lower load carrying capacities than the original tires because they may lower your vehicle's GVWR and GAWR limitations. Replacement tires with a higher limit than the original tires do not increase the GVWR and GAWR limitations.

Overloading

WARNING

The Gross Axle Weight Rating (GAWR) and the Gross Vehicle Weight Rating (GVWR) for your vehicle are on the Certification Label attached to the driver's (or front passenger's) door. Exceeding these ratings can cause an accident or vehicle damage. You can calculate the weight of your load by weighing the items (and people) before putting them in the vehicle. Be careful not to overload your vehicle

Forward Collision-Avoidance Assist (FCA) (Sensor Fusion).....	6-4
• Forward Collision-Avoidance Assist settings	6-7
• Forward Collision-Avoidance Assist operation	6-9
• Forward Collision-Avoidance Assist malfunction and limitations.....	6-18
Lane Keeping Assist (LKA).....	6-25
• Lane Keeping Assist settings	6-26
• Lane Keeping Assist operation.....	6-27
• Lane Keeping Assist malfunction and limitations.....	6-28
Blind-Spot Collision-Avoidance Assist (BCA)	6-31
• Blind-Spot Collision-Avoidance Assist settings.....	6-32
• Blind-Spot Collision-Avoidance Assist operation	6-34
• Blind-Spot Collision-Avoidance Assist malfunction and limitations.....	6-36
Safe Exit Warning (SEW)	6-40
• Safe Exit Warning settings	6-40
• Safe Exit Warning operation	6-41
• Safe Exit Warning malfunction and limitations	6-42
Manual Speed Limit Assist (MSLA)	6-44
• Manual Speed Limit Assist operation.....	6-44
Intelligent Speed Limit Assist (ISLA).....	6-46
• Intelligent Speed Limit Assist settings.....	6-46
• Intelligent Speed Limit Assist operation.....	6-47
• Intelligent Speed Limit Assist malfunction and limitations.....	6-49
Driver Attention Warning (DAW)	6-51
• Driver Attention Warning settings	6-51
• Driver Attention Warning operation	6-51
• Driver Attention Warning malfunction and limitations.....	6-53
Blind-Spot View Monitor (BVM)	6-55
• Blind-Spot View Monitor settings	6-55

6 Driver assistance guide

- Blind-Spot View Monitor operation.....6-56
- Blind-Spot View Monitor malfunction.....6-56
- Smart Cruise Control (SCC) 6-57**
 - Smart Cruise Control settings6-58
 - Smart Cruise Control operation.....6-59
 - Smart Cruise Control malfunction and limitations.....6-66
- Navigation-based Smart Cruise Control (NSCC) 6-70**
 - Navigation-based Smart Cruise Control settings6-71
 - Navigation-based Smart Cruise Control operation6-71
 - Navigation-based Smart Cruise Control limitations6-72
 - This device complies with Industry Canada licence-exempt RSS standard(s).....6-75
- Lane Following Assist (LFA) 6-75**
 - Lane Following Assist settings6-76
 - Lane Following Assist operation.....6-76
 - Lane Following Assist malfunction and limitations.....6-78
- Highway Driving Assist (HDA) 6-79**
 - Highway Driving Assist settings6-80
 - Highway Driving Assist operation6-81
 - Highway Driving Assist malfunction and limitations.....6-87
 - This device complies with Industry Canada licence-exempt RSS standard(s).....6-88
- Rear View Monitor (RVM)..... 6-89**
 - Rear View Monitor settings6-89
 - Rear View Monitor operation.....6-90
 - Rear View Monitor malfunction and limitations.....6-92
- 360° camera monitoring system..... 6-93**
 - 360° camera monitoring system settings.....6-93
 - 360° camera monitoring system operation.....6-94
 - 360° camera monitoring system malfunction and limitations.....6-97
- Rear Cross-Traffic Collision-Avoidance Assist (RCCA) 6-98**

- Rear Cross-Traffic Collision-Avoidance Assist settings..... 6-98
- Rear Cross-Traffic Collision-Avoidance Assist operation.....6-99
- Rear Cross-Traffic Collision-Avoidance Assist malfunction and limitations..... 6-102
- This device complies with Industry Canada licence-exempt RSS standard(s)..... 6-105
- Forward/Reverse Parking Distance Warning (PDW) 6-106**
- Forward/Reverse Parking Distance Warning settings..... 6-106
- Forward/Reverse Parking Distance Warning operation..... 6-107
- Forward/Reverse Parking Distance Warning malfunction and precautions 6-108
- Forward/Side/Reverse Parking Distance Warning (PDW) ...6-111**
- Forward/Side/Reverse Parking Distance Warning settings.....6-112
- Forward/Side/Reverse Parking Distance Warning operation ...6-112
- Forward/Side/Reverse Parking Distance Warning malfunction and precautions 6-115
- Reverse Parking Collision-Avoidance Assist (PCA)6-117**
- Reverse Parking Collision-Avoidance Assist settings6-117
- Reverse Parking Collision-Avoidance Assist operation..... 6-118
- Reverse Parking Collision-Avoidance Assist malfunction and limitations..... 6-119
- Declaration of conformity 6-123**

Driver assistance guide

* INFORMATION

The description of the driver assistance system displayed on the screen may differ from the content of the owner's manual depending on the infotainment software version.

Forward Collision-Avoidance Assist (FCA) (Sensor Fusion) (if equipped)

Basic function



Forward Collision-Avoidance Assist detects a vehicle, a powered two-wheeler, a pedestrian, or a cyclist ahead on the road and may warn you of a possible collision with a warning message on the instrument cluster and a warning sound. Also, Forward Collision-Avoidance Assist may assist with braking your vehicle to help reduce collision speed or avoid a collision.

Forward Collision-Avoidance Assist can detect vehicles ahead and adjacent lanes even at high speeds. If the driver makes a lane change at those speeds, your vehicle can apply emergency braking to mitigate or avoid a collision. (if equipped)

Junction Turning function

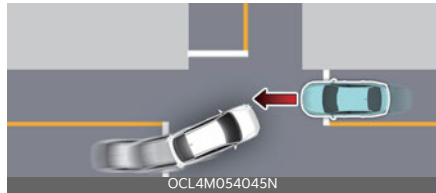

Junction Turning function can help avoid a collision with an oncoming vehicle, powered two-wheeler and cyclist in an oncoming lane when turning left at a crossroad with the turn signal on by applying emergency braking.

Direct Oncoming function



1. Oncoming vehicle

Direct Oncoming function can help reduce the speed at the collision when with a vehicle or powered two-wheeler approaching from the opposite side is detected.

Junction Crossing function (if equipped)



Junction Crossing function can help mitigate or avoid a collision with oncoming vehicles on the left or right side when

crossing an intersection by applying emergency braking.

Lane-Change Oncoming function (if equipped)

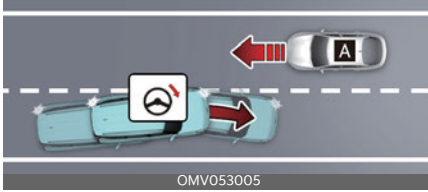

1. Oncoming vehicle

Lane-Change Oncoming function can help mitigate or avoid a collision with oncoming vehicles or powered two-wheelers when changing lanes by assisting the driver's steering.

Lane-Change Side function (if equipped)

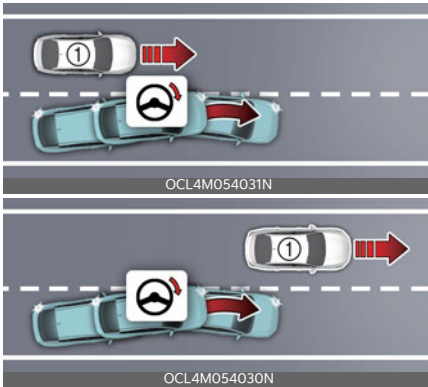

1. Approaching car from side

Lane-Change Side function can help mitigate or avoid a collision with vehicles or powered two-wheelers in the next lane when changing lanes by assisting the driver's steering.

Evasive Steering Assist function (if equipped)

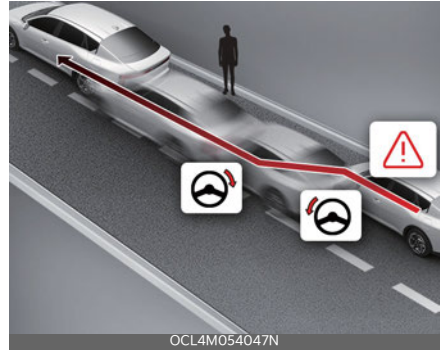

- Driver steering assist
If a possible collision with a vehicle ahead, pedestrian, cyclist, etc. is detected and you steer to avoid the collision, Evasive Steering Assist can assist the driver in steering.
- Evasive steering assist
Evasive Steering Assist function can help mitigate or avoid a collision with pedestrian or cyclist in the same lane in front of you. When a risk of collision is detected, Evasive Steering Assist function can warn you and assist your steering if you move the steering wheel.

Detecting sensor

Front view camera



Front view camera (GT-Line)



Front radar



Front radar (GT-Line)



Front corner radar (if equipped)



Front corner radar (GT-Line)



Rear corner radar (if equipped)



Rear corner radar (GT-Line)



Refer to the picture above for the detailed location of the detecting sensors.

⚠ CAUTION

- Never disassemble the detecting sensor or sensor assembly, or cause any damage to it.
- If the detecting sensors have been replaced or repaired, have the vehicle inspected by an authorized Kia dealer.
- If the radar or around the radar experiences an impact, Forward Collision-Avoidance Assist may not operate properly even if a warning message is not displayed on the cluster. Have the vehicle inspected by an authorized Kia dealer.
- Never install any accessories or stickers on the windshield, or tint the windshield.
- Pay extreme caution to keep the front view camera dry.
- Never place any reflective objects (for example, white paper, mirror) over the instrument panel.

- Do not place any objects near the windshield or install any accessories on the windshield. It can affect the performance of the defogging and defrosting function of the climate control system, which may prevent the Driver Assistance systems from operating.
- Do not apply license plate frame or objects, such as a bumper sticker, film or a bumper guard, near the front radar cover.
- Always keep the front radar and cover clean and free of dirt and debris. Use only a soft cloth to wash the vehicle. Do not spray pressurized water directly on the sensor or sensor cover.
- The genuine Kia front/front corner/rear corner radar sensor covers are parts with quality and performance ensured. If arbitrarily applying paint on or changing the cover, Forward Collision-Avoidance Assist may not function properly. Use only Kia Genuine Parts or those of an equivalent standard with proven quality and performance to repair or replace the radar sensor covers.
- Do not apply objects, such as a bumper sticker or a bumper guard, near the wide angle cameras or ultrasonic sensors or apply paint to the bumper.
- The function may not work properly when the bumper has been replaced, or the surroundings of the front corner radar or rear corner radar has been damaged or paint has been applied.
- If a trailer, carrier, etc. is installed, it may adversely affect the performance

of Forward Collision-Avoidance Assist may not operate properly.

Forward Collision-Avoidance Assist settings

Forward Safety



- 1 Driver Assistance
- 2 Driving Safety
- 3 Forward Safety

With the vehicle on, select **Setup** → **Vehicle** → **Driver Assistance** → **Driving Safety** on the infotainment system. The initial warning activation timing of Forward Collision-Avoidance Assist can be changed.

- Forward safety:** Collision warning or emergency braking will operate in a collision-imminent situation. If you deselect the setting, Forward safety will turn off and the Forward Safety warning light (🚨) will appear on the cluster.

Forward Cross-Traffic Safety (if equipped)



- 1 Driver Assistance
- 2 Driving Safety
- 3 Forward Cross-Traffic Safety

With the vehicle on, select **Setup** → **Vehicle** → **Driver Assistance** → **Driving Safety** → **Forward Cross-Traffic Safety** from the infotainment system screen to turn on Junction Crossing function and deselected to turn off the function.

Forward/Side Safety (if equipped)

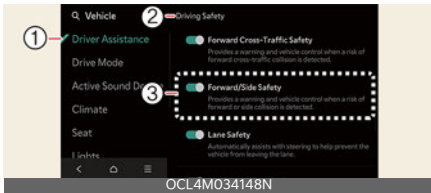

- 1 Driver Assistance
- 2 Driving Safety
- 3 Forward/Side Safety

With the vehicle on, select **Setup** → **Vehicle** → **Driver Assistance** → **Driving Safety** → **Forward/Side Safety** on the infotainment system.

- **Forward/Side Safety:** Collision warning or emergency steering will assist the driver in a collision-imminent situation. If you deselect the setting, Forward safety will turn off and the Emergency steering warning light (🚗) will appear on the cluster.

The driver can monitor Forward Collision-Avoidance Assist On/Off status from the Settings menu. If the Forward Safety warning light (🚗) or Emergency steering warning light (🚗) remains ON when Forward safety or Forward/side safety is selected, have the vehicle inspected by an authorized Kia dealer.

⚠️ WARNING

When the vehicle is restarted, Forward Collision-Avoidance Assist will always turn on. However, if **Forward safety** is

deselected, the driver should always be aware of the surroundings and drive safely.

⚠️ CAUTION

- Steering wheel vibration can be turned on or off.
- Forward safety settings include 'Basic function', 'Junction Turning function', and 'Direct On coming function'. Forward Cross-Traffic Safety include 'Junction Crossing function', Forward/Side Safety includes 'Lane change oncoming function', 'Lane change side function' and 'Evasive Steering Assist function'. (if equipped)
- If Forward safety is set to Off, Even if Forward Cross-Traffic safety and Forward/Side Safety is selected, 'Junction Crossing function' will not operate. (if equipped)

Forward Safety Warning Timing



- 1 Driver Assistance
- 2 Driving Safety
- 3 Forward Safety Warning Timing

With the vehicle on, select **Setup** → **Vehicle** → **Driver Assistance** → **Driving Safety** → **Forward Safety Warning Timing** on the infotainment system to change the initial warning activation timing of Forward Collision-Avoidance Assist.

- Use **Standard** in normal driving conditions. If the Warning Timing seems sensitive, change it to **Late**.
- If **Late** is selected, Forward Collision-Avoidance Assist, warns the driver more slowly.

⚠ CAUTION

- Even though **Standard** is selected for Warning Timing, if the front vehicle suddenly stops, the warning may seem late.
- Select **Late** for Warning Timing when traffic is light and when driving speed is slow.

*** INFORMATION**

- Forward/side safety does not provide the warning timing setting.
- The warning timing you have set will be maintained even if the vehicle is restarted

- the function may warn you with a low volume.
- **Haptic Warning:** Activate the steering wheel vibration warning.
- **Driving Safety Priority:** Lowers all other audio volumes when the Driving Safety system sounds a warning.

*** INFORMATION**

- Ensure that **Warning Methods** you have set may apply to the **Warning Methods** of other driver assistance systems.
- **The Warning Methods** will maintain their last settings when the vehicle is restarted.
- The setting menu may not be available for your vehicle depending on the vehicle features and specifications.
- The **Warning Volume** and **Haptic Warning** cannot be turned off at the same time. When one of the warning is turned off the other is activated.

Warning Methods

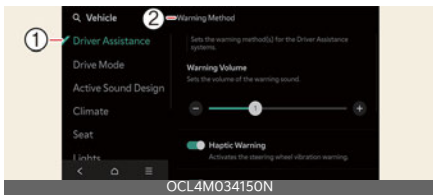

- 1 Driver Assistance
- 2 Warning Methods

our vehicle may allow you to change the **Warning Methods** setting. To do so, select **Setup** → **Vehicle** → **Driver Assistance** → **Warning Methods** in the infotainment system to change the following settings:

- **Warning Volume:** Adjusts the volume of the warning sound. If you turn off the **Warning Volume**, for your safety,

Forward Collision-Avoidance Assist operation

Basic function

The basic function for Forward Collision-Avoidance Assist is warned and controlled in the following way.

- Collision warning
- Emergency braking
- Stopping vehicle and ending brake control

Collision Warning

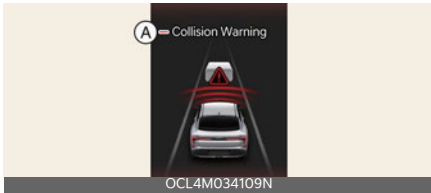

A: Collision Warning

Collision Warning can alert the driver with the Forward Safety warning light (🚨) blinking, warning message, an audible warning and steering wheel vibration.

The collision warning operates under the following vehicle speed conditions, depending on the vehicle in front.

- Vehicle or powered two-wheeler: 10~200 km/h (6~124 mph)
- Pedestrian or cyclist: 10~85 km/h (6~53 mph)

Emergency Braking

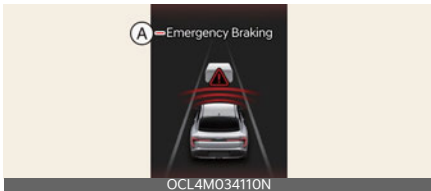

A: Emergency Braking

Emergency braking will alert the driver with the Forward Safety warning light (🚨) blinking, warning message, an audible warning and steering wheel vibration.

Emergency braking will be activated to help avoid a collision with a vehicle ahead, pedestrian, cyclist and powered two-wheeler.

- Vehicle or powered two-wheeler:

-	Driving target	Stopped target
Weak braking power	10~200 km/h (6~124 mph)	
Strong braking power	10~130 km/h (6~80 mph)	10~75 km/h (6~47 mph) (10~85 km/h (6~62 mph))*

*: If Forward Collision Avoidance Assist judges that avoiding a collision is difficult even by changing the driving lane. The function operate range may decrease due to surroundings of the vehicle. (if equipped)

- Pedestrian or cyclist: 10~65 km/h (6~40 mph)

⚠ CAUTION

- The function operation range may decrease due to the front traffic condition or the surroundings of the vehicle.
- When driving at night, the performance of powered two-wheeler recognition is decreased, so the Forward Collision-Avoidance Assist system may be temporarily limited or may not work.

Stopping vehicle and ending brake control

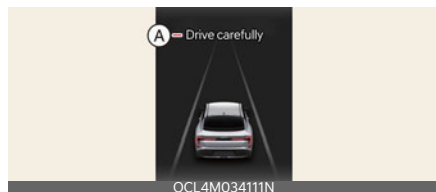

A: Drive carefully

When the vehicle is stopped due to emergency braking, the warning message will appear on the cluster.

For your safety, the driver should depress the brake pedal immediately and check the surroundings.

- Brake control will end after the vehicle is stopped by emergency braking for approximately 2 seconds.

*** NOTICE**

The warning sound during collision warning and emergency braking can be switched off by pressing the hazard warning light.

Junction Turning function

The Junction turning function is warned and controlled in the following way.

- Collision Warning
- Emergency Braking
- Stopping vehicle and ending brake control

Collision Warning



A: Collision Warning

Collision Warning can alert the driver with the Forward Safety warning light (🚨) blinking, warning message, an audible warning and steering wheel vibration.

Collision warning will be activated in the following conditions:

- Your driving speed: Approximately 10-30 km/h (6-19 mph)
- Oncoming vehicle speed: Approximately 25-70 km/h (15-44 mph)

- Powered two-wheeler and cyclist speed: Approximately 15-70 km/h (9-44 mph)

Emergency Braking

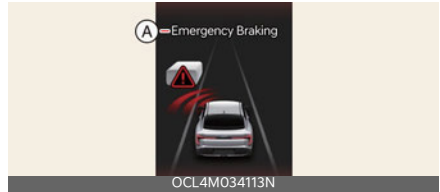

A: Emergency Braking

Emergency braking can alert the driver with the Forward Safety warning light (🚨) blinking, warning message, an audible warning and steering wheel vibration. The brake assist can be activated and to help avoid a collision with an oncoming vehicle and powered two-wheeler.

Emergency braking will be activated in the following conditions.

- Your driving speed: 10~30 km/h (6~19 mph)
- Oncoming vehicle speed: Approximately 25-70 km/h (15-44 mph)
- Powered two-wheeler and cyclist speed: Approximately 15-70 km/h (9-44 mph)

Stopping vehicle and ending brake control

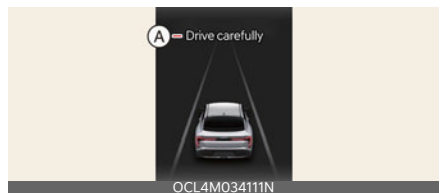

A: Drive carefully

When the vehicle is stopped due to emergency braking, a warning message will appear on the cluster.

For your safety, the driver should depress the brake pedal immediately and check the surroundings.

- Brake control will end after the vehicle is stopped by emergency braking for approximately 2 seconds.

*** NOTICE**

The warning sound during collision warning and emergency braking can be switched off by pressing the hazard warning light.

*** INFORMATION**

When turning right (left-hand drive) or left (right-hand drive) at an intersection, braking is assisted to reduce or avoid collisions if there is a collision risk with a cyclist approaching at the speed of 15 to 20 km/h (9 to 12 mph) from the opposite side.

Direct Oncoming function

The Direct Oncoming function is warned and controlled in the following way.

- Collision Warning
- Emergency Braking
- Stopping vehicle and ending brake control

Collision Warning

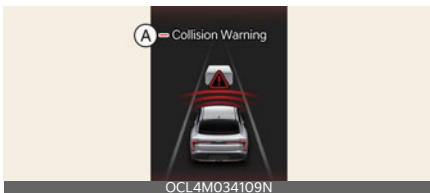

A: Collision Warning

Collision warning can alert the driver with the Forward Safety warning light (🚗) blinking, warning message, an audi-

ble warning and steering wheel vibration.

The brake assist will be activated and to help avoid a collision with an oncoming vehicle and powered two-wheeler.

Collision Warning will be activated in following conditions.

- Your driving speed: Approximately 10~130 km/h (6~80 mph)
- Oncoming vehicle or Powered two-wheeler speed: Approximately above 10 km/h (6 mph)

Emergency braking

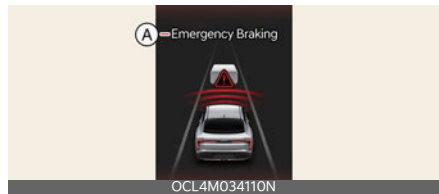

A: Emergency Braking

Emergency braking can alert the driver with the Forward Safety warning light (🚗) blinking, warning message, an audible warning and steering wheel vibration.

Emergency braking will be activated in following conditions.

- Your driving speed: Approximately 30~130 km/h (19~80 mph)
- Oncoming vehicle or Powered two-wheeler speed: Approximately above 10 km/h (6 mph)

Stopping vehicle and ending brake control

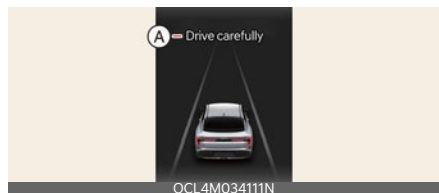

A: Drive carefully

When the vehicle is stopped due to emergency braking, a warning message will appear on the cluster.

For your safety, the driver should depress the brake pedal immediately and check the surroundings.

- Brake control will end after the vehicle is stopped by emergency braking for approximately 2 seconds

⚠ CAUTION

- If your vehicle, powered two-wheeler or the oncoming vehicle is not driving straight, Front Oncoming function warning and control may be late or may not operate.
- When driving at night, the performance of t powered two-wheeler recognition is decreased, so the Forward Collision-Avoidance Assist system may be temporarily limited or may not work.

*** NOTICE**

The warning sound during collision warning and emergency braking can be switched off by pressing the hazard warning light.

Junction Crossing function (if equipped)

The Junction Crossing function is warned and controlled by the following level.

- Collision Warning
- Emergency Braking
- Stopping vehicle and ending brake control

Collision Warning



A: Collision Warning

Collision Warning can alert the driver with the Forward Safety warning light (🚦) blinking, warning message, an audible warning and steering wheel vibration.

Forward collision warning will be activated in the following conditions.

- Your driving speed: Approximately 10-55km/h (6-34 mph)
- Crossing vehicle speed: Approximately 10-60km/h (6-37 mph)

Emergency Braking

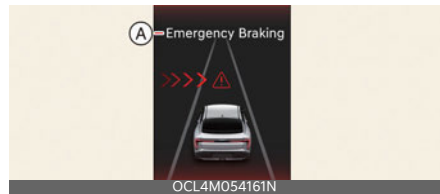

A: Emergency Braking

The Forward Safety warning light (🚦) blinking, warning message, an audible warning and the steering wheel vibration that emergency braking will be assisted. The brake assist can be activated and help mitigate or avoid a collision with a vehicle, pedestrian cyclist, or powered two-wheeler.

Emergency braking will be activated in the following conditions.

- Your driving speed: Approximately 10-55km/h (6-34 mph)

- Crossing vehicle speed: Approximately 10-40km/h (6-25 mph)

Stopping vehicle and ending brake control



A: Drive carefully

When the vehicle is stopped due to emergency braking, a warning message will appear on the cluster.

For your safety, the driver should depress the brake pedal immediately and check the surroundings.

- Brake control will end after the vehicle is stopped by emergency braking for approximately 2 seconds.

CAUTION

If the collision angle with the crossing vehicle is beyond a certain range, Junction Crossing Warning and control may be late or may not operate.

Lane-Change Oncoming function (if equipped)

The Lane-change oncoming function is warned and controlled in the following way.

- Collision Warning
- Emergency Steering

Collision Warning

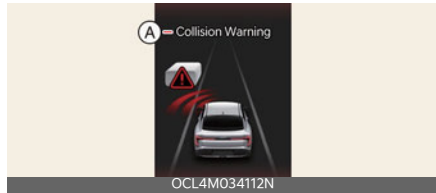

A: Collision Warning

Collision warning can alert the driver with the Emergency steering warning light (⚠️) blinking, warning message, an audible warning and steering wheel vibration.

Collision warning will be activated in the following conditions.

- Your driving speed: Approximately 40~145 km/h (25~90 mph)
- Oncoming vehicle or powered two-wheeler speed: Approximately above 10 km/h (6 mph)
- Relative speed: Approximately below 200 km/h (124 mph)

Emergency Steering

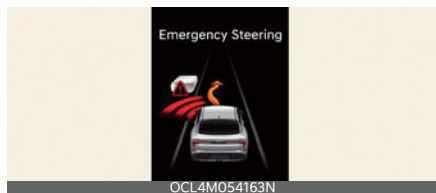

A: Emergency Steering

Emergency steering can alert the driver with the Emergency steering warning light (⚠️) blinking, warning message, an audible warning and steering wheel vibration. The steering assist will be activated to help mitigate or avoid a collision with an oncoming vehicle or powered two-wheelers.

Emergency steering will be activated in following conditions.

- Your driving speed: Approximately 40~145 km/h (25~90 mph)
- Oncoming vehicle or powered two-wheeler speed: Approximately above 10 km/h (6 mph)
- Relative speed: Approximately below 200 km/h (124 mph)

Lane-Change Side function (if equipped)

Lane-change side function is warned and controlled in the following way.

- Collision Warning
- Emergency Steering

Collision Warning



A: Collision Warning

Collision warning will alert the driver with the emergency steering warning light (⚠️) blinking, warning message, an audible warning and steering wheel vibration. The warning light will appear on the outside rear-view mirror when the vehicle either on a right or left lane is detected from the rear.

Collision warning will be activated in following conditions.

- Your driving speed: Approximately 40~145 km/h (25~90 mph)

Emergency Steering

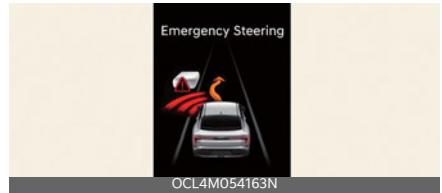

A: Emergency Steering

To warn the driver that emergency steering will be assisted, the emergency steering warning light (⚠️) blinking, warning message will appear on the cluster, an audible warning will sound and the steering wheel will vibrate.

The warning light on the outside rear-view mirror will appear when the vehicle on both lanes is detected from the rear. Steering will be assisted to avoid collision.

Emergency steering will be activated in following conditions.

- Your driving speed: Approximately 40~145 km/h (25~90 mph)

⚠️ CAUTION

- Lane-Change Side function does not operate if the oncoming vehicle from the front side is stopped.
- These functions do not work when a flanking car or two-wheeled vehicle is stationary.
- The detection range of the front-side and rear-side radars is based on the standard road width of ordinary roads. On narrow roads, warnings may be triggered by a vehicle or powered two-wheeler driving in the next lane. Conversely, on wide roads, radars may fail to recognize a vehicle or powered two-wheeler driving in the next lane and not issue warnings.

- The lateral approaching vehicle response function is deactivated in the following situations:
 - If you drive more than a certain distance into the next lane
 - If you move away from the direction where there is a risk of collision
 - If the steering wheel is rotated rapidly
 - If you step on the brake pedal
 - If Forward Collision-Avoidance Assist is activated
- After the lateral approaching vehicle response function has been triggered or after changing lanes, be sure to move into the center of the lane. If you continue to drive along the edge of the lane without moving to the lane's center, the lateral approaching vehicle response function will be deactivated.

*** NOTICE**

- If an additional accident is expected due to emergency steering, only a collision warning will be issued to notify of the danger.
- If the driver's seat is on the left, a collision warning may be issued when turning left; if the driver's seat is on the right, a collision warning may be issued when turning right.

Evasive Steering Assist function (if equipped)

The Evasive Steering Assist function is warned and controlled in the following way.

- Emergency Steering

Emergency Steering (Driver steering assist)

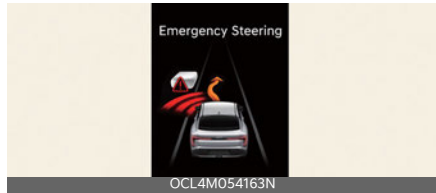

A: Emergency Steering

Emergency steering will alert the driver with the emergency steering warning light (⚠) blinking, warning message, an audible warning and steering wheel vibration.

If there is a risk of collision with a vehicle, a pedestrian, a cyclist, or a powered two-wheeler in front, the steering will be assisted to help prevent collision when the driver steers the vehicle to avoid collision.

Emergency Steering can be activated in following conditions.

- Your driving speed: Approximately 40~85 km/h (25~53 mph)

Emergency Steering (Evasive steering assist)

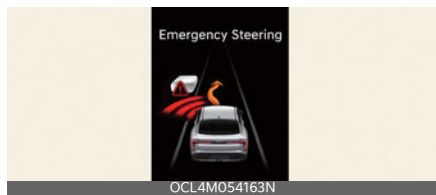

A: Emergency Steering

Emergency steering will alert the driver with the emergency steering warning light (⚠) blinking, warning message, an audible warning and steering wheel vibration.

If there is a risk of collision with a pedestrian, a cyclist, or a powered two-wheeler

in front and your vehicle already exceeded the emergency braking speed limit, the steering will be assisted to help prevent collision when the driver steers the vehicle to avoid collision.

Emergency Steering will be activated in following conditions.

- Your driving speed: Approximately 65~75 km/h (40~47 mph)

⚠ CAUTION

- The steering wheel may turn automatically when emergency steering is operating.
- Emergency steering will automatically cancel when risk factors disappear. If necessary, the driver must steer the vehicle.
- Emergency steering may not operate or may cancel during operation if the steering wheel is held tight or steered in the opposite direction.
- When steering is assisted to avoid collision with a vehicle, pedestrian and cyclist, Evasive steering assist will be canceled if collisions with other objects (vehicle, powered two-wheeler, pedestrians, or cyclists) are expected.
- Evasive steering assist may not operate if space to avoid collision in the driving lane is insufficient.
- When driving at night, the performance of powered two-wheeler recognition is decreased, so the Forward Collision-Avoidance Assist system may be temporarily limited or may not work.

*** NOTICE**

For more details on warning messages, refer to "Collision Warning" on page 6-10.

⚠ WARNING

- For your safety, change the Settings after parking the vehicle at a safe location.
- Forward Collision-Avoidance Assist does not operate in all situations or cannot avoid all collisions.
- The driver should hold the responsibility to control the vehicle. Do not solely depend on Forward Collision-Avoidance Assist. Rather, maintain a safe braking distance, and if necessary, depress the brake pedal to reduce driving speed or to stop the vehicle.
- Never deliberately operate Forward Collision-Avoidance Assist on people, objects, etc. It may cause serious injury or death.
- Forward Collision-Avoidance Assist may not operate if the driver depresses the brake pedal to avoid collision.
- Depending on the road and driving conditions, Forward Collision-Avoidance Assist may warn the driver late or may not warn the driver.
- During Forward Collision-Avoidance Assist operation, the vehicle may stop suddenly injuring passengers and shifting loose objects. Always have the seat belt on and keep loose objects secured.
- If any other function's warning message is displayed or audible warning is generated, Forward Collision-Avoidance Assist warning message may not

be displayed and audible warning may not be generated.

- You may not hear the warning sound of Forward Collision-Avoidance Assist if the surrounding is noisy.
- Forward Collision-Avoidance Assist may turn off or may not operate properly or may operate unnecessarily depending on the road conditions and the surroundings.
- During emergency braking, braking control by Forward Collision-Avoidance Assist will automatically cancel when the driver excessively depresses the accelerator pedal or sharply steers the vehicle.

⚠ CAUTION

- The surroundings and pedestrians, cyclists and powered two-wheeler or other vehicles in front of you may affect the speed or detection range to operate Forward Collision-Avoidance Assist, resulting in Forward Collision-Avoidance Assist temporarily limited or disabled.
- Forward collision avoidance assistance operates under specific conditions, taking into account the status of the oncoming vehicle and powered two-wheeler, driving direction, speed, and surrounding environment to judge the level of risk.
- The function may be limited or deactivated in cases where the driving speed is excessively high or there is a significant speed difference between the oncoming vehicle powered two-wheelers.
- When a collision with a surrounding vehicle is expected, Lane-change oncoming, Lane-change side and Eva-

sive steering assist functions will only warn the driver.

*** NOTICE**

- When a collision is imminent, the Forward Collision-Avoidance Assist may assist the driver with brakes if the driver fails to brake enough.
- The images or colors on the instrument cluster may be different from those in this manual.

Forward Collision-Avoidance Assist malfunction and limitations

Forward Collision-Avoidance Assist malfunction

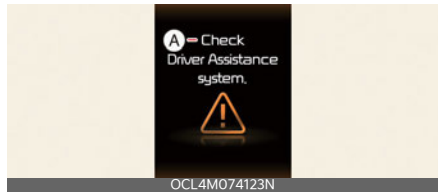

A: Check Driver Assistance system
 When Forward Collision-Avoidance Assist is not working properly, the warning message will appear, and the Forward Safety warning light (🚗), the Emergency Steering warning light (🚗) and the Master warning light (⚠) will appear on the cluster. Have the vehicle inspected by an authorized Kia dealer.

Forward Collision-Avoidance Assist disabled

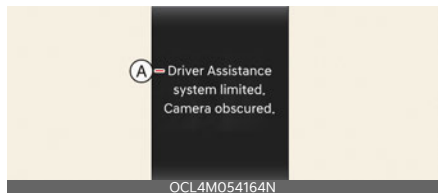

A: Driver Assistance system limited. Camera obscured.

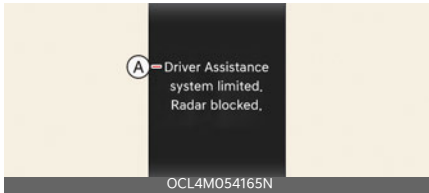

A: Driver Assistance system limited. Radar blocked.

When the windshield where the front view camera is located, front radar cover, bumper or sensor is covered with foreign material, such as snow or rain, it can reduce the detecting performance and temporarily limit or disable Forward Collision-Avoidance Assist.

If this occurs a warning message, and the Forward Safety warning light (⚠️), the Emergency Steering warning light (🚘) and the Master warning light (⚠️) will appear on the cluster.

Forward Collision-Avoidance Assist will operate properly when snow, rain or foreign material is removed.

If Forward Collision-Avoidance Assist does not operate properly after obstruction (snow, rain, or foreign material) is removed (including trailer, carrier, etc. from the rear bumper), have the vehicle inspected by an authorized Kia dealer.

⚠️ WARNING

Even though the warning message or warning light does not appear on the cluster, Forward Collision-Avoidance Assist may not properly operate.

* NOTICE

You can check it in the service message of the utility information view of the cluster display window.

Limitations of Forward Collision-Avoidance Assist

Forward Collision-Avoidance Assist may not operate normally, or it may operate unexpectedly under the following circumstances:

- A sensor or the its surroundings are contaminated or damaged
- The temperature around the front-view camera is extremely high or low
- The camera lens is obscured by a tinted, filmed or coated windshield, by damaged glass, or by foreign material (sticker, bug, etc.) on the glass
- There is moisture or ice on the windshield
- Heavy rain, snow, or fog obscure the camera's view
- The field of view of the front view camera is obstructed by sun glare
- Light is reflected off a wet road surface, such as a puddle in the road
- An object is placed on the instrument panel
- The surroundings are very bright (e.g., glare) or very dark (e.g., in a tunnel).
- The light changes suddenly, (e.g., when entering or exiting a tunnel)
- Dark conditions, when the headlamps are not on or are obscured, or the other vehicle has no taillights
- Only part of the vehicle, powered two-wheeler, pedestrian or cyclist is detected

- The vehicle in front is a bus, heavy truck, truck with an unusually shaped cargo, trailer, etc.
- The vehicle or powered two-wheeler in front has no taillights or its, taillights are in unusual positions
- The rear of the front vehicle is small or the vehicle does not look normal, such as when the vehicle is tilted or over-turned Clarify
- The other vehicle's ground clearance is extremely low or high
- A vehicle, powered two-wheeler, pedestrian or cyclist suddenly cuts in front
- The front radar or its surroundings are impacted, damaged, or out of position
- The temperature around the front radar is high or low
- The temperature of the front radar is extremely high or low
- Driving in areas where there are few vehicles or structures (for example, desert, meadow, etc.)
- Driving near areas containing metal substances, such as a construction zone, railroad, metal plates on the road.
- A material is near that reflects very well on the front radar, such as a guardrail, nearby vehicle.
- The cyclist in front is on a bicycle made of material that does not reflect on the front radar's signal
- The vehicle or powered two-wheeler appears suddenly
- The view of the vehicle or powered two-wheeler is suddenly blocked
- The vehicle or powered two-wheeler in front suddenly changes a lane or suddenly reduces speed

- The vehicle in front is covered with snow
- You are departing or returning to the lane
- Unstable driving
- You are on a roundabout and the vehicle or powered two-wheeler in front is not detected
- You are continuously driving in a circle
- The vehicle or powered two-wheeler in front has an unusual shape
- The vehicle or powered two-wheeler in front is on a steep hill, out of range of the camera and radar



The illustration above shows the kinds of images that the front view camera and front radar are capable of detecting as a vehicle, powered two-wheeler, pedestrian and cyclist. The system may not detect a pedestrian or cyclist that is:

- leaning over or is not fully walking upright
- The pedestrian or cyclist is wearing clothing or equipment that makes it difficult to detect
- The pedestrian or cyclist in front is moving very quickly
- The pedestrian or cyclist in front is short or is posing a low posture
- The pedestrian or cyclist in front has impaired mobility or moving intersected with the driving direction

- There is a group of pedestrians, cyclists or a large crowd in front
 - The pedestrian or cyclist is wearing clothing that easily blends into the background, making it difficult to detect
 - The pedestrian or cyclist is difficult to distinguish from the similarly shaped structure in the surroundings
 - You are driving by a pedestrian, cyclist, traffic signs, structures, etc., near the intersection
 - When driving in the following places
 - Driving through steam, smoke, or shadow
 - Driving through a tunnel or iron bridge
 - Driving in large areas where there are few vehicles or structures (i.e., desert, meadow, suburb, etc.)
 - Driving in a car park
 - Driving through tollgate, construction areas, partially paved roads, bumpy roads, speed bumps, etc.
 - Driving near areas containing metal substances, such as a construction zone, railroad, etc.
 - Driving on an inclined road, curved road, etc.
 - Driving through a roadside with trees or street lights
 - Driving through a narrow road where trees or grass are overgrown
 - There is interference by electromagnetic waves, such as driving in an area with strong radio waves or electrical noise
 - A snow chain, spare tire, or wheel of a different size is installed
- Junction Crossing, Lane-Change Oncoming, Lane-Change Side, Evasive Steering Assist function (if equipped)**
- The temperature around the front corner radar or rear corner radar is high or low
 - A trailer or carrier is installed around the rear corner radar
 - The front corner radar or rear corner radar is covered with snow, rain, dirt, etc.
 - The bumper around the front corner radar or rear corner radar is covered with objects, such as a bumper sticker, bumper guard, bike rack, etc.
 - The bumper around the front corner radar or rear corner radar is impacted, damaged or the radar is out of position
 - The front corner radar or rear corner radar is blocked by other vehicles, walls or pillars
 - Driving on a highway (or motorway) ramp
 - Driving on a road where the guardrail or wall is in double structure
 - The other vehicle or powered two-wheeler drives very close behind your vehicle, or the other vehicle passes by your vehicle in close proximity
 - The speed of the other vehicle or powered two-wheeler is very fast that it passes by your vehicle in a short time
 - Your vehicle passes by the other vehicle or powered two-wheeler
 - Your vehicle has started at the same time as the vehicle or powered two-wheeler next to you and has accelerated

- The vehicle or powered two-wheeler in the next lane moves two lanes away from you, or when the vehicle two lanes away moves to the next lane from you
- A motorcycle or bicycle is detected
- A vehicle such as a flat trailer is detected
- A big vehicle such as a bus or truck is detected
- A small moving obstacle such as a pedestrian, animal, shopping cart or a baby pushchair is detected
- A vehicle with low height such as a sports car is detected
- The lane is difficult to see due to foreign material, such as rain, snow, dust, sand, oil and water puddles
- The color of the lane marking is not distinguishable from the road
- There are markings on the road near the lane or the markings on the road looks similar to the lane markings
- The shadow is on the lane marking by a median strip, trees, guardrail, noise barriers, etc.
- The lane number increases or decreases, or the lane markings are crossing
- There are more than two-lane markings on the road
- The lane markings are complicated or a structure substitutes for the lines, such as a construction area
- There are road markings, such as zig-zag lanes, crosswalk markings and road signs
- The lane suddenly disappears, such as at the intersection
- The lane is very wide or narrow
- There is a curb or road edges without a lane

- The vehicle in front is driving with one side on the lane marking
- The distance to the front vehicle is extremely short

*** NOTICE**

For more details on the limitations of detecting rear corner vehicles and cautions regarding the rear corner sensor, please refer to the "Blind-Spot Collision-Avoidance Assist (BCA) (if equipped)" on page 6-31.

⚠ WARNING

- Driving on a curved road

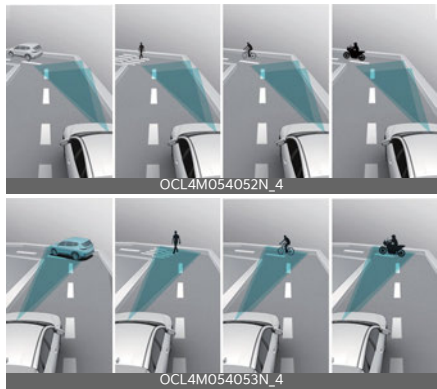

Forward Collision-Avoidance Assist may not detect other vehicles, powered two-wheelers, pedestrians or cyclists in front of you when driving on curved roads. This may result in no warning, braking assist or steering assist when necessary.

When driving on a curve, you must maintain a safe braking distance, and if necessary, steer the vehicle and depress the brake pedal to reduce your driving speed in order to maintain a safe distance.

Forward Collision-Avoidance Assist may detect a vehicle, powered two-

wheeler, pedestrian or cyclist in the next lane or outside the lane when driving on a curved road.

If this occurs, Forward Collision-Avoidance Assist may unnecessarily warn the driver and control the brake or steering. Always check the traffic conditions around the vehicle.

- Driving on an inclined road



Forward Collision-Avoidance Assist may not detect other vehicles, powered two-wheelers, pedestrians or cyclists in front of you while driving uphill or downhill, adversely affecting the performance of the sensors.

This may not help warning, braking or steering when necessary.

Also, vehicle speed may rapidly decrease when a vehicle, powered two-wheeler, pedestrian or cyclist ahead is suddenly detected.

Always have your eyes on the road while driving uphill or downhill and if necessary, steer your vehicle and depress the brake pedal to reduce your driving speed in order to maintain a safe distance.

- Changing lanes

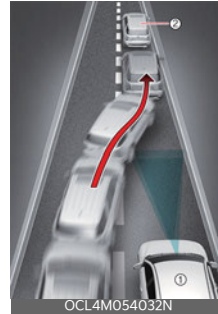

1. Your vehicle
2. Lane changing vehicle or powered two-wheelers

When a vehicle or powered two-wheelers (2) moves into your lane from an adjacent lane, it cannot be detected by the sensor until it is in the sensor's detection range.

Forward Collision-Avoidance Assist may not immediately detect a vehicle or powered two-wheelers when a vehicle or powered two-wheelers changes lanes abruptly. In this case, you must maintain a safe braking distance, and if necessary, steer your vehicle and depress the brake pedal to reduce your driving speed in order to maintain a safe distance.

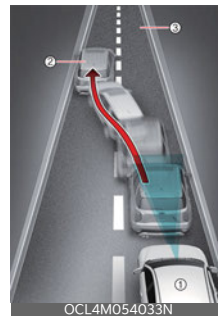

1. Your vehicle

- 2. Lane changing vehicle or powered two-wheelers
- 3. Same lane vehicle

When a vehicle (2) in front of you merges out of the lane, Forward Collision-Avoidance Assist may not immediately detect a vehicle or powered two-wheelers (3) that is now in front of you. In this case, you must maintain a safe braking distance, and if necessary, steer your vehicle and depress the brake pedal to reduce your driving speed in order to maintain a safe distance.

- Detecting a vehicle

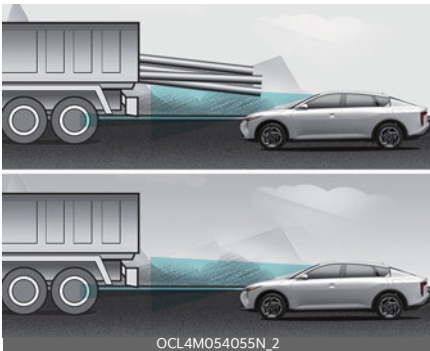

If the vehicle in front of you has cargo that extends rearward from the cab, or when the vehicle in front of you has higher ground clearance, additional special attention is required. Forward Collision-Avoidance Assist may not be able to detect the cargo extending from the vehicle. In these instances, you must maintain a safe braking distance from the rearmost object, and if necessary, steer your vehicle and depress the brake pedal to reduce your driving speed in order to maintain distance.

⚠ WARNING

- When you are towing a trailer or another vehicle, we recommend that Forward Collision-Avoidance Assist is turned off due to safety reasons.
- Forward Collision-Avoidance Assist may operate if objects that are similar in shape or characteristics to vehicles, powered two-wheelers, pedestrians and cyclists are detected.
- Forward Collision-Avoidance Assist does not operate on carts, bicycles, suitcases, strollers, etc., which are pulled or pushed by pedestrians or cyclists.
- Forward Collision-Avoidance Assist may not operate normally if interfered by strong electromagnetic waves.
- Forward Collision-Avoidance Assist may not operate for 15 seconds after the vehicle is started, or the front view camera is initialized.

*** NOTICE**

For more details on the limitations of detecting rear corner vehicles and cautions regarding the rear corner sensor, please refer to "Blind-Spot Collision-Avoidance Assist (BCA) (if equipped)" on page 6-31.

This device complies with Industry Canada licence-exempt RSS standard(s).

Operation is subject to the following three conditions:

1. This device may not cause interference, and
2. This device must accept any interference, including interference that may cause undesired operation of the device.
3. Changes or modifications not expressly approved by the party responsible for compliance could void the user's authority to operate the device.

Lane Keeping Assist (LKA)

While driving over a certain speed, Lane Keeping Assist detects lane markings (or road edges) and may warn you if your vehicle leaves the lane without using the turn signal and may assist with steering to prevent your vehicle departing from its travel lane.

Detecting sensor

Front view camera



Front view camera (GT-Line)



The front view camera is used as a detecting sensor to detect lane markings (or road edges).

⚠ CAUTION

For more details on the precautions of the front view camera, refer to "Forward Collision-Avoidance Assist (FCA) (Sensor Fusion) (if equipped)" on page 6-4.

Lane Keeping Assist settings

Lane Safety

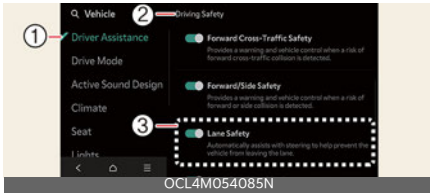

- 1 Driver Assistance
- 2 Driving Safety
- 3 Lane Safety

With the vehicle on, select **Setup** → **Vehicle** → **Driver Assistance** → **Driving Safety** on the infotainment system.

- **Lane Safety:** When lane departure is detected, the system assists with steering to prevent leaving the lane, and if lane departure occurs, it alerts the driver with an audible sound and the steering wheel vibration. If Lane safety is deselected, the indicator light () will turn off.

WARNING

- If Lane safety is deselected, you will not receive assistance from Lane Keeping Assist. Always drive with caution.
- When the vehicle is turned off and restarted, Lane Keeping Assist will automatically turn on and Lane Safety will be automatically selected. This feature may vary depending on the region where the vehicle is sold.
- Lane Keeping Assist does not control the steering wheel when the vehicle is driven in the middle of the lane.

NOTICE

By pressing the Lane Driving Assist button () , the Lane Keeping Assist will be

turned off, and it will also deactivate the Lane Safety.

Warning Methods

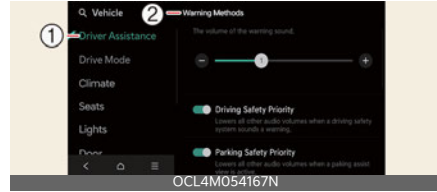

- 1 Driver Assistance
- 2 Warning Methods

The Warning Methods can be set with the vehicle on. Select **Setup** → **Vehicle** → **Driver Assistance** → **Warning Methods** from the settings menu in the infotainment system to change the following settings:

- **Warning Volume:** Adjusts the volume of the warning sound.
- **Haptic Warning:** Activate the steering wheel vibration warning.
- **Lane Safety Audible Warning:** Turns off the Lane Safety Audible Warning, when both warning volume and haptic warning are on.
- **Driving Safety Priority:** Lowers all other audio volumes when the Driving Safety system sounds a warning.

INFORMATION

- If you change the Warning Methods, it can be applied to each function of the driver assistance system. Please check and change it in each function.
- If the vehicle is restarted, Warning Methods will maintain the last setting. The setting menu may not exist based on vehicle specification.
- The **Warning Volume** and **Haptic Warning** cannot be turned off at the

same time. When one of the warning is turned off the other is activated.

- The **Lane Safety Audible Warning** can be set when both the Warning Volume and the Haptic Warning are on.

Lane Keeping Assist operation

Turning Lane Keeping Assist On/Off



OCL4M054006N

With the vehicle on, press and hold the Lane Driving Assist (LKA) button located on the steering wheel to turn on and off Lane Keeping Assist.

The gray or green indicator (LKA icon) on the cluster will light up if you turn on Lane Keeping Assist.

* NOTICE

- If Lane Keeping Assist is standby, the gray indicator (LKA icon) will appear on the cluster.
- If Lane Keeping Assist is ready to operate, the green indicator (LKA icon) will appear on the cluster.

Warning and control

The Lane Keeping Assist function is warned and controlled in the following way.

- Lane Departure Warning
- Lane Keeping Assist



OCL4M054087N



OCL4M054086N

Lane Departure Warning

Lane departure warning is issued through a green indicator light on the cluster, a blinking indicator in the direction you departed from, a warning sound and the steering wheel will vibrate.

Lane Departure Warning will be activated in the following conditions.

- Your driving speed: Approximately 60-200 km/h (40-120 mph)

Lane Keeping Assist

The green (LKA icon) indicator light will blink on the cluster, and the steering wheel makes adjustments to keep vehicle inside the lane.

Lane Keeping Assist will be activated in the following conditions.

- Your driving speed: Approximately 60-200 km/h (40-120 mph)

Hands-off warning

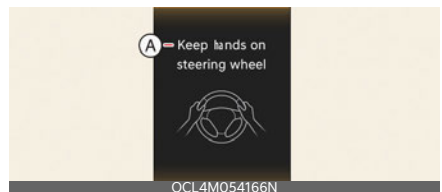

OCL4M054166N

A: Keep hands on steering wheel

If the driver takes their hands off the steering wheel for several seconds, the warning message will appear on the cluster, and an audible warning will sound in stages.

⚠ WARNING

- The steering wheel may not be assisted if the steering wheel is held very tight or the steering wheel is steered over a certain degree.
- Lane Keeping Assist does not operate at all times. It is the responsibility of the driver to safely steer the vehicle and to maintain the vehicle in its lane.
- The hands-off warning message may appear late depending on road conditions. Always have your hands on the steering wheel while driving.
- If the steering wheel is held very lightly, the hands-off warning message may appear because Lane Keeping Assist may not recognize that the driver has their hands on the steering wheel.
- If you attach objects to the steering wheel, the hands-off warning may not work properly.

*** NOTICE**

- Even though the steering is assisted by Lane Keeping Assist, the driver may control the steering wheel.
- The steering wheel may feel heavier or lighter when the steering wheel is assisted by Lane Keeping Assist than when it is not.
- If you select Highway Lane Change Assist, the green lane will appear on the cluster. (if equipped)

- If the vehicle detects the lane markings, the gray-colored lane lines turn white on the cluster.

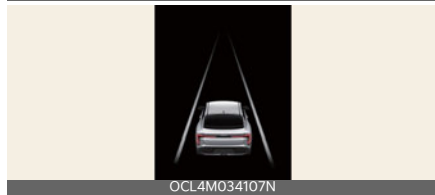

- The images and colors in the instrument cluster may differ depending on the cluster type or theme selected from the settings menu.
- For more details on the instrument cluster, refer to "LCD display" on page 4-67.

Lane Keeping Assist malfunction and limitations

Lane Keeping Assist malfunction

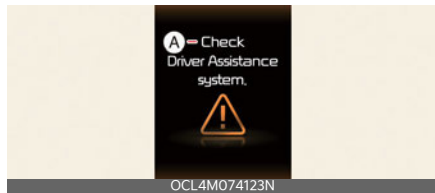

A: Check Driver Assistance system.

When Lane Keeping Assist is not working properly, the warning message will appear the Master warning light (⚠) and the yellow (🚗) indicator light will appear on the cluster.

If this occurs, have Lane Keeping Assist inspected by an authorized Kia dealer.

Lane Keeping Assist disabled

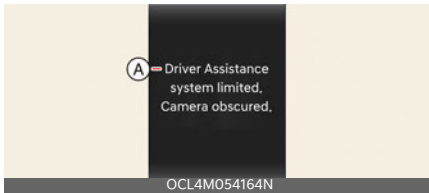

A: Driver Assistance system limited. Camera obscured.

If foreign materials such as snow or rain block the sensors or the windshield where the front view camera is located, the detecting performance may be reduced, resulting in Lane Keeping Assist temporarily limited or disabled. In this case, a warning message is displayed with the Master warning light (⚠) and the Lane safety warning lights (🚦) on the cluster. This is normal operation.

Lane Keeping Assist will operate properly after cleaning snow, rain or foreign materials. Always keep it clean.

If Lane Keeping Assist still does not operate properly after cleaning foreign materials (snow, rain, etc.) or removing obstructions (including trailer, carrier, etc. from the rear bumper), have the vehicle inspected by an authorized Kia, dealer.

⚠ WARNING

- Even though the warning message or warning light does not appear on the cluster, Lane Keeping Assist may not operate normally.
- Even after starting the vehicle again, Lane Keeping Assist may not function properly when the obstruction or malfunction condition persists.

* NOTICE

You can check it in the service message of the utility information view of the cluster display window.

Limitations of Lane Keeping Assist

Lane Keeping Assist may not operate properly or may operate unexpectedly under the following circumstances:

- The lane is contaminated or difficult to detect because:
 - The lane markings (or road edges) are covered with rain, snow, dirt, oil, etc.
 - The color of the lane marking (or road edges) is not distinguishable from the road
 - There are markings (or road edges) on the road near the lane or the markings (or road edges) on the road look similar to the lane markings (or road edges)
 - The lane marking (or road edges) is indistinct or damaged
 - When the shadow of objects around the road (central reservation, crash barrier, noise barrier, surrounding bushes, etc.) or the shadow of a vehicle covers the lane.
- The lane number increases or decreases, or the lane markings (or road edges) are crossing
- There are more than two lane markings (or road edges) on the road
- The lane markings (or road edges) are complicated or a structure is substituted for the lines, such as in a construction area

- There are road markings, such as zig-zag lanes, crosswalk markings and road signs
- The lane suddenly disappears, such as at the intersection
- The lane (or road width) is very wide or narrow
- There is a road edge without a lane
- There is a boundary structure in the roadway, such as a tollgate, sidewalk, curb, etc.
- The distance to the front vehicle is extremely short or the vehicle in front is covering the lane marking (or road edge)

* NOTICE

For more details on the limitations of the front view camera, refer to "Forward Collision-Avoidance Assist (FCA) (Sensor Fusion) (if equipped)" on page 6-4.

⚠ WARNING

- The driver should hold the responsibility to safely drive and control the vehicle. Do not solely rely on Lane Keeping Assist and drive dangerously.
- The operation of Lane Keeping Assist can be canceled or not work properly depending on road conditions and surroundings. Always be cautious while driving.
- Refer to "Lane Keeping Assist malfunction and limitations" on page 6-28 if the lane is not detected properly.
- When you are towing a trailer or another vehicle, turn off Lane Keeping Assist for safety reasons.
- If the vehicle is driven at high speed, the steering wheel will not be controlled. The driver must always follow the speed limit when using Lane Keeping Assist.
- If any other function's warning message is displayed or audible warning is generated, Lane Keeping Assist warning message may not be displayed and audible warning may not be generated.
- You may not hear the warning sound of Lane Keeping Assist if the surrounding is noisy. Adjust the vehicle volume moderately and always pay attention to the surrounding.
- If you attach objects to the steering wheel, steering may not be assisted properly.
- Lane Keeping Assist may not operate for approximately 15 seconds after the vehicle is started, or the front view camera is initialized.
- Lane Keeping Assist will not operate when:
 - The turn signal or hazard warning flasher is turned on.
 - The vehicle is not driven in the center of the lane when Lane Keeping Assist is turned on or right after changing a lane.
 - ESC (Electronic Stability Control) or VSM (Vehicle Stability Management) is activated.
 - The vehicle is turning quickly on a curved road.
 - Vehicle speed is below 55 km/h (35 mph) or above 210 km/h (130 mph).
 - The vehicle makes sharp lane changes.
 - The vehicle brakes suddenly.
- Loading in excess of the maximum load allowance or concentrated loading at one point in the cargo compart-

ment can reduce the vehicle's driving stability, which can in turn reduce the effectiveness of Lane Keeping Assist.

Blind-Spot Collision-Avoidance Assist (BCA) (if equipped)

Blind-Spot Collision-Avoidance Assist detects approaching vehicles in the driver's blind spot areas and warn you of a possible collision with a warning light and a warning sound. If there is a collision risk when exiting a parallel space when Blind-Spot Collision-Avoidance Assist may assist with braking your vehicle to help avoid a collision.



Blind-Spot Collision-Avoidance Assist helps detect and informs the driver that a vehicle is in the blind spot.

⚠ CAUTION

The detecting range may vary depending on the speed of your vehicle. Even if there is a vehicle in the blind spot area, Blind-Spot Collision-Avoidance Assist may not warn you when you pass by at high speeds.

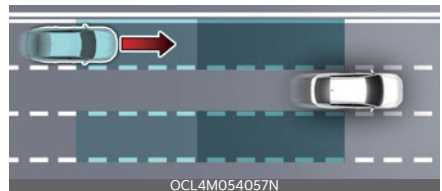

Blind-Spot Collision-Avoidance Assist helps detect and informs the driver that a vehicle is approaching at high speed from the blind spot area.

CAUTION

Warning timing may vary depending on the speed of the vehicle approaching at high speed.

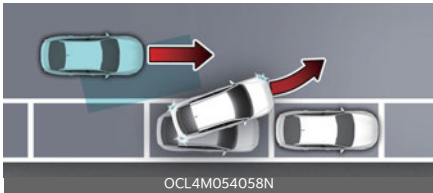

When you are driving forward out of a parking space, if Blind-Spot Collision-Avoidance Assist judges that there is a collision risk with an approaching vehicle in the blind spot, it can help avoid collision by applying the brake.

Detecting sensor

Rear corner radar



Rear corner radar (GT-Line)



CAUTION

- Never disassemble the detecting sensor assembly, or cause any damage to it.
- If the detecting sensor or near the sensor has been damaged or

impacted in any way, even though the warning message does not appear on the cluster, Blind-Spot Collision-Avoidance Assist may not operate properly. Have the Blind-Spot Collision-Avoidance Assist inspected by an authorized Kia dealer.

- If the detecting sensors have been replaced or repaired, have the vehicle inspected by an authorized Kia dealer.
- The genuine Kia rear bumpers which the Rear corner radar sensors are mounted are parts with quality and performance ensured. If arbitrarily applying paint on or changing the bumper, the Blind-Spot Collision-Avoidance Assist may not function properly. Use only Kia Genuine Parts or those of an equivalent standard with proven quality and performance to repair or replace the bumper.
- Do not apply license plate frame or objects, such as a bumper sticker, film or a bumper guard near the rear corner radar.
- If a trailer, carrier, etc., is installed, it may adversely affect the performance of the rear corner radar or Blind-Spot Collision-Avoidance Assist may not operate.

Blind-Spot Collision-Avoidance Assist settings

Blind-Spot Safety

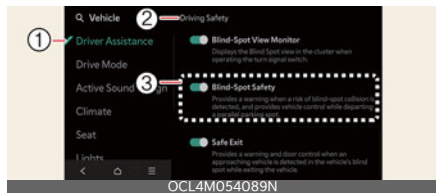

1 Driver Assistance

2 Driving Safety

3 Blind-Spot Safety

With the vehicle on, select **Setup** → **Vehicle** → **Driver Assistance** → **Blind-Spot Safety** on the infotainment system.

- **Blind-Spot Safety:** Blind-Spot Collision-Avoidance Assist will warn and braking assist will be applied depending on the collision risk levels.

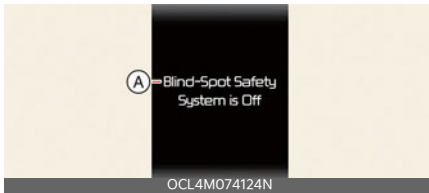

A: Blind-Spot Safety System is Off

When activating Blind-Spot Collision-Avoidance Assist or restarting the vehicle with this function activated, the warning light on the outside rear view mirror will appear for approximately 3 seconds.

When the vehicle is restarted with Blind-Spot Collision-Avoidance Assist inactivated, the warning message will appear on the cluster.

▲ WARNING

If **Blind-Spot Safety** is deselected, you cannot get help from **Blind-Spot Collision-Avoidance Assist**. The driver should always be aware of the surroundings and drive safely.

*** NOTICE**

If the vehicle is restarted, Blind-Spot Collision-Avoidance Assist will maintain the last setting.

Warning Methods

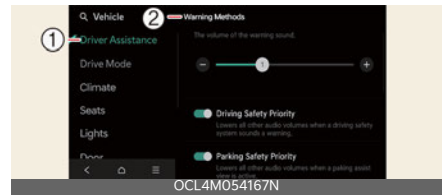

1 Driver Assistance

2 Warning Methods

The Warning Methods can be set with the vehicle on. Select **Setup** → **Vehicle** → **Driver Assistance** → **Warning Methods** from the settings menu in the infotainment system to change the following settings:

- **Warning Volume:** Adjusts the volume of the warning sound.
- **Haptic Warning:** Activate the steering wheel vibration warning.
- **Blind-Spot Safety warning volume:** If the **Blind-Spot Safety warning volume** is deactivated, the warning volume will be turned off.
- **Driving Safety Priority:** Lowers all other audio volumes when the Driving Safety system sounds a warning.

*** INFORMATION**

- If you change the Warning Methods, it can be applied to each function of the driver assistance system. Please check and change it in each function.
- If the vehicle is restarted, Warning Methods will maintain the last setting.
- **The setting menu may not exist based on vehicle specification.**
- The Warning Volume and Haptic Warning cannot be turned off at the same time. When one of the warning is turned off the other is activated.

Blind-Spot Collision-Avoidance Assist operation

Blind-Spot Collision-Avoidance Assist will warn and control as following operation.

- Collision warning (while driving)
- Collision-avoidance assist (while departing)

Collision warning (while driving)

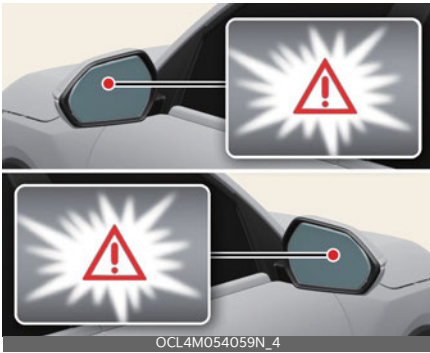

The warning light on the cluster, outside rear view mirror will appear when the vehicle on both lanes is detected from the rear.

A vehicle is detected in the following conditions.

- Your driving speed: Above 20 km/h (12 mph)
- The speed of the vehicle in your blind spot area: Above 10 km/h (7 mph)

With the vehicle detection state, Collision warning will alert the driver when the turn signal is activated to make a lane change with an adjacent car in the blind spot area.

- Collision warning will alert the driver with the warning light on the cluster, outside rear view mirror, an audible warning and steering wheel vibration.

- When the turn signal is turned off or you move away from the lane, the collision warning will be canceled and the function will return to Vehicle detection state.

Collision Warning operate in the following conditions.

- Your driving speed: Above 40 km/h (25 mph)
- The speed of the vehicle in your blind spot area: Above 10 km/h (7 mph)

⚠ WARNING

- The detecting range of the rear corner radar is determined by a standard road width, therefore, on a narrow road, Blind-Spot Collision-Avoidance Assist may detect other vehicles two lanes over and warn you. In contrast, on a wide road, Blind-Spot Collision-Avoidance Assist may not be able to detect a vehicle driving in the next lane and may not warn you.
- When the hazard warning flasher is on, the collision warning by the turn signal will not operate.

* NOTICE

- If the driver's seat is on the left side, the collision warning may occur when you turn left. If the driver's seat is on the right side, the collision warning may occur when you turn right. Maintain a proper distance with the vehicles in the lane.
- Images or colors may be displayed differently depending on the instrument cluster specifications or theme.

Collision-Avoidance Assist (while departing)

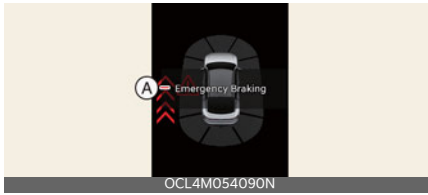

A: Emergency Braking

The warning light on the outside rear view mirror, an audible warning and steering wheel vibration will warn the driver of a collision. It assists in braking control to prevent a collision with a vehicle approaching from the blind spot area.

Collision-Avoidance Assist will be activated in the following conditions.

- Your driving speed: Below 3 km/h (2 mph)
- Speed of the vehicle in your blind spot area: Above 5 km/h (3 mph)

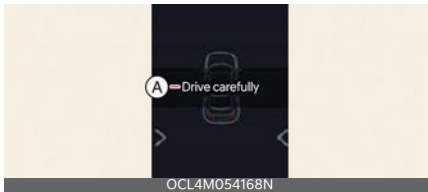

A: Drive carefully

When the vehicle is stopped due to emergency braking, the warning message will appear on the cluster. For your safety, the driver should depress the brake pedal immediately and check the surroundings.

- Brake control will end after the vehicle is stopped by emergency braking for approximately 2 seconds.

⚠ WARNING

- For your safety, change the Settings after parking the vehicle at a safe location.
- If any other function's warning message is displayed or audible warning is generated, Blind-Spot Collision-Avoidance Assist's warning message may not be displayed and audible warning may not be generated.
- You may not hear the warning sound of Blind-Spot Collision-Avoidance Assist if the surrounding is noisy. Always pay attention and keep the vehicle volume at a moderate level.
- Blind-Spot Collision-Avoidance Assist may not operate if the driver applies the brake pedal to avoid collision.
- When Blind-Spot Collision-Avoidance Assist is operating, braking control by the function will automatically cancel when the driver excessively depresses the accelerator pedal or sharply steers the vehicle.
- During Blind-Spot Collision-Avoidance Assist operation, the vehicle may stop suddenly injuring passengers and shifting loose objects. Always have the seat belt on and keep loose objects secured.
- Even if there is a problem with Blind-Spot Collision-Avoidance Assist, the vehicle's basic braking performance will operate properly.
- Blind-Spot Collision-Avoidance Assist may not operate in all situations, and even if it works, it may not be able to avoid collisions.
- Blind-Spot Collision-Avoidance Assist may warn the driver late or may not warn the driver depending on the road and driving conditions.

- The responsibility for vehicle operation lies with the driver. Do not rely solely on Blind-Spot Collision-Avoidance Assist for driving and always check the surrounding conditions directly and drive safely.
- Never operate Blind-Spot Collision-Avoidance Assist on people, animal, objects, etc. It may cause serious injury or death.

⚠ WARNING

The brake control may not operate properly depending on the status of ESC (Electronic Stability Control).

There will only be a warning when:

- The ESC (Electronic Stability Control) warning light is on
- ESC (Electronic Stability Control) is engaged in a different function

Blind-Spot Collision-Avoidance Assist malfunction and limitations

Blind-Spot Collision-Avoidance Assist malfunction

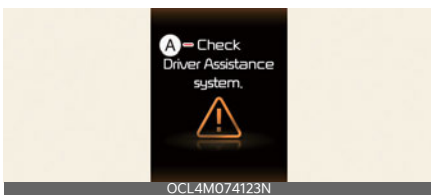

A: Check Driver Assistance system.

When Blind-Spot Collision-Avoidance Assist is not working properly, the warning message will appear on the cluster for several seconds, and the Master warning light (⚠) will appear on the cluster.

If this occurs, have Blind-Spot Collision-Avoidance Assist inspected by an authorized Kia dealer.

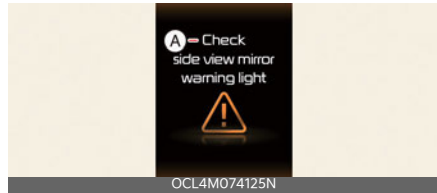

A: Check side view mirror warning light

When the outside rear view mirror warning light is not working properly, the warning message will appear on the cluster for several seconds, and the Master warning light (⚠) will appear on the cluster. If this occurs, have Blind-Spot Collision-Avoidance Assist by an authorized Kia dealer.

Blind-Spot Collision-Avoidance Assist disabled

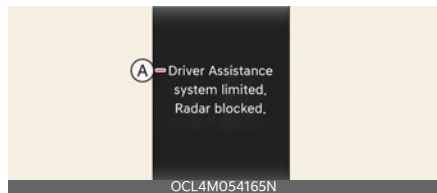

A: Driver Assistance system limited. Radar blocked.

Covering the rear bumper around the rear corner radar or sensor with foreign materials, such as snow or rain, or installing a trailer or carrier can reduce the detecting performance, resulting in Blind-Spot Collision-Avoidance Assist temporarily limited or disabled.

At this time, the warning message and the Master warning light (⚠) are displayed on the cluster display, but it does not indicate a malfunction of Blind-Spot Collision-Avoidance Assist.

Blind-Spot Collision-Avoidance Assist will operate properly when such foreign material or trailer, etc., is removed, and then the vehicle is restarted.

If Blind-Spot Collision-Avoidance Assist does not operate properly after it is removed, have Blind-Spot Collision-Avoidance Assist inspected by an authorized Kia dealer.

WARNING

- Even though a warning message does not appear on the cluster, Blind-Spot Collision-Avoidance Assist may not properly operate.
- Blind-Spot Collision-Avoidance Assist may not properly operate in an area (for example, open terrain) where any objects are not detected right after the vehicle is turned on, or when the detecting sensor is blocked with foreign material right after the vehicle is turned on.

CAUTION

Turn off Blind-Spot Collision-Avoidance Assist to install or remove a trailer, carrier, or another attachment. Turn on Blind-Spot Collision-Avoidance Assist when finished.

NOTICE

You can check it in the service message of the utility information view of the cluster display window.

Limitations of Blind-Spot Collision-Avoidance Assist

Blind-Spot Collision-Avoidance Assist may not operate properly, or it may operate unexpectedly under the following circumstances:

- There is inclement weather, such as heavy snow and heavy rain.
- The detecting sensor is covered with snow, rain, dirt, etc.
- The temperature around the detecting sensor is high or low due to the surrounding environment.
- The detecting sensor is blocked while driving near a vehicle, pillar, or wall.
- Driving on a highway (or motorway) ramp or driving through a tollgate.
- The road pavement (or the peripheral ground) abnormally contains metallic components (for example, possibly due to subway construction).
- There is a fixed object near the vehicle, such as sound barriers, guardrails, central dividers, entry barriers, streetlamps, signs, tunnels, walls, etc. (including double structures)
- Driving through a narrow road where trees or grass are overgrown
- Driving in vast areas where there are few vehicles or structures (for example, desert, meadow, suburb, etc.)
- Driving on a wet road surface, such as a puddle on the road
- The other vehicle drives very close behind your vehicle, or the other vehicle passes by your vehicle in close proximity
- The speed of the other vehicle is very fast that it passes by your vehicle in a short time
- Your vehicle passes by the other vehicle
- Your vehicle changes lane
- Your vehicle has started at the same time as the vehicle next to you and has accelerated
- The vehicle in the next lane moves two lanes away from you, or when the

vehicle two lanes away moves to the next lane from you

- A trailer or carrier is installed around the rear corner radar
- The bumper around the rear corner radar is covered with objects, such as a bumper sticker, bike rack, etc.
- The bumper around the rear corner radar is impacted, damaged or the radar is out of position
- Your vehicle height is low or high due to heavy loads, abnormal tire pressure, etc.
- When the following objects are detected:
 - A motorcycle or bicycle is detected
 - A vehicle such as a flat trailer is detected
 - A big vehicle such as a bus or truck is detected
 - A moving obstacle such as a pedestrian, animal, shopping cart or a baby pushchair is detected
 - A vehicle with low height such as a sports car is detected

Pay attention. Braking control may not operate in the following conditions:

- The vehicle severely vibrates while driving over a bumpy road, uneven road or concrete patch
- Driving on a slippery surface due to snow, water puddle, ice, etc.
- The tire pressure is low or a tire is damaged
- The braking system has been modified
- When steering urgently

⚠ WARNING

- Driving on a curved road



Blind-Spot Collision-Avoidance Assist may not operate properly when driving on a curved road. Blind-Spot Collision-Avoidance Assist may not detect the vehicle in the next lane.

Always pay attention to road and driving conditions while driving.



Blind-Spot Collision-Avoidance Assist may not operate properly when driving on a curved road. Blind-Spot Collision-Avoidance Assist may detect a vehicle in the same lane.

Always pay attention to road and driving conditions while driving.



Blind-Spot Collision-Avoidance Assist may not operate properly when driv-

ing on an inclined road. The function may not detect the vehicle in the next lane or may incorrectly detect the ground or structure.

Always pay attention to road and driving conditions while driving.

- Driving where the road is merging/dividing



Blind-Spot Collision-Avoidance Assist may not operate properly when driving where the road merges or divides. The function may not detect the vehicle in the next lane.

Always pay attention to road and driving conditions while driving.

- Driving where the heights of the lanes are different



Always pay attention to road and driving conditions while driving.

Blind-Spot Collision-Avoidance Assist may not operate properly when driving where the heights of the lanes are different. The function may not detect the vehicle on a road with different lane heights (underpass joining section, grade separated intersections, etc.).

⚠ WARNING

- When you are towing a trailer or another vehicle, make sure that you turn off Blind-Spot Collision-Avoidance Assist.
- Blind-Spot Collision-Avoidance Assist may not operate properly if interfered by strong electromagnetic waves.
- Blind-Spot Collision-Avoidance Assist may not operate for approximately 3 seconds after the vehicle is started, or the front view camera or rear corner radars are initialized.

This device complies with Industry Canada licence-exempt RSS standard(s).

Operation is subject to the following two conditions:

1. This device may not cause interference, and
2. This device must accept any interference, including interference that may cause undesired operation of the device.

Safe Exit Warning (SEW) (if equipped)



While your vehicle is stopped, and if Safe Exit Warning detects a vehicle approaching the rear corner of your vehicle and a passenger opens a door, Safe Exit Warning may warn you with a warning message and a warning sound to help avoid a collision.

⚠ CAUTION

Warning timing may vary depending on the speed of the approaching vehicle.

Detecting sensor

Rear corner radar



Rear corner radar (GT-Line)



⚠ CAUTION

For more details on the precautions of the rear corner radars, refer to "Blind-

Spot Collision-Avoidance Assist (BCA) (if equipped)" on page 6-31.

Safe Exit Warning settings

Safe Exit



1 Driver Assistance

2 Driving Safety

3 Safe Exit

With the vehicle on, select **Setup** → **Vehicle** → **Driver Assistance** → **Driving Safety** → **Safe Exit** on the infotainment system.

⚠ WARNING

If **Safe Exit** is deselected, Safe Exit Warning cannot warn you. The driver should always be aware of unexpected and sudden situations from occurring.

*** NOTICE**

If the vehicle is restarted, Safe Exit Warning will maintain the last setting.

Warning Methods

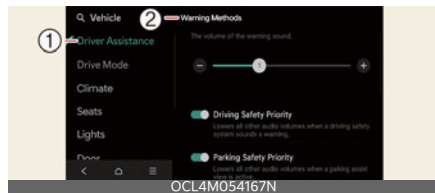

1 Driver Assistance

2 Warning Methods

The Warning Methods can be set with the vehicle on. Select **Setup** → **Vehicle** → **Driver Assistance** → **Warning Methods** from the settings menu in the infotainment system to change the following settings:

- **Warning Volume:** Adjusts the volume of the warning sound.
If you turn off the **Warning Volume**, for your safety, the function may warn you with a low volume.
- **Driving Safety Priority:** Lowers all other audio volumes when the Driving Safety system sounds a warning.

*** INFORMATION**

- If you change the Warning Methods, it can be applied to each function of the driver assistance system. Please check and change it in each function.
- If the vehicle is restarted, Warning Methods will maintain the last setting.
- The setting menu may not exist based on vehicle specification.

Safe Exit Warning operation

Warning and control

Safe Exit Warning warns the following actions.

- Collision warning when exiting vehicle

Collision warning when exiting vehicle



A: Collision Warning

The warning light on the outside rear view mirror will blink and the warning message will appear on the cluster, and an audible warning will sound.

- Safe Exit Warning will warn under the following circumstances:
 - Your driving speed: below 3 km/h (2 mph)
 - The speed of the approaching vehicle from the rear: above 6 km/h (4 mph)

⚠ WARNING

- For your safety, change the Settings after parking the vehicle at a safe location.
- If any other function's warning message is displayed or audible warning is generated, Safe Exit Warning message may not be displayed and audible warning may not be generated.

- You may not hear the warning sound of Safe Exit Warning if the surrounding is noisy.
- Safe Exit Warning may not operate in all situations or cannot prevent all collisions.
- Safe Exit Warning may warn the driver late or may not warn the driver depending on the vehicle and driving conditions. Always check vehicle surroundings.
- The driver and passengers are responsible for accidents that occur while exiting the vehicle. Always check the surroundings before you exit the vehicle.

*** NOTICE**

- After the vehicle is turned off, Safe Exit Warning operates for approximately 3 minutes, but turns off immediately if the doors are locked.
- Images or colors may be displayed differently depending on the instrument cluster specifications or theme.

Safe Exit Warning malfunction and limitations

Safe Exit Warning malfunction

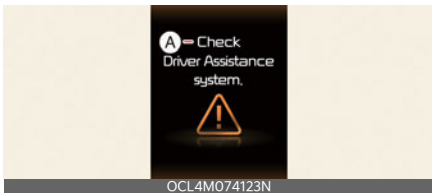

A: Check Driver Assistance system.
 When Safe Exit Warning is not working properly, the warning message will appear on the cluster, and the Master warning light (⚠️) will appear on the cluster for certain time.

Have Safe Exit Warning inspected by an authorized Kia dealer.

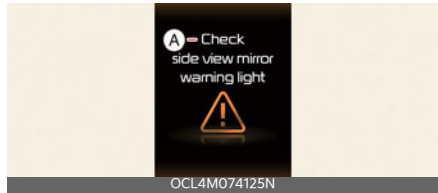

A: Check side view mirror warning light

When the outside rear view mirror warning light is not working properly, the warning message will appear on the cluster for certain time, and the Master warning light (⚠️) will appear on the cluster.

Have Safe Exit Warning inspected by an authorized Kia dealer.

Safe Exit Warning disabled

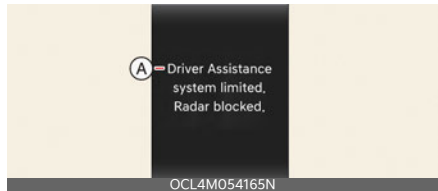

A: Driver Assistance system limited. Radar blocked.

When the rear bumper around the rear corner radar or sensor is covered with foreign material, such as snow or rain, or installing a trailer or carrier, it can reduce the detecting performance and temporarily limit or disable Safe Exit Warning. At this time, warning messages and the Master warning lights (⚠️) are displayed on the cluster display, but it does not indicate a malfunction of the safe exit assist.

Safe Exit Warning will operate normally when such foreign material or trailer, etc.

is removed, and then the vehicle is restarted.

If Safe Exit Warning does not operate normally after it is removed, have the vehicle inspected by an authorized Kia dealer.

⚠ WARNING

- Even though the warning message does not appear on the cluster, Safe Exit Warning may not properly operate.
- Safe Exit Warning may not properly operate in an area (e.g., open terrain), where any substance are not detected right after the vehicle is turned on, or when the detecting sensor is blocked with foreign material right after the vehicle is turned on.

⚠ CAUTION

When using cargo racks or other equipment, turn off the Safe Exit Warning. To use Safe Exit Warning, remove cargo racks or other equipment.

*** NOTICE**

You can check it in the service message of the utility information view of the cluster display window.

Limitations of Safe Exit Warning

Safe Exit Warning may not operate normally, or Safe Exit Warning may operate unexpectedly under the following warning.

- Getting out of the vehicle where trees or grass are overgrown
- Getting out of the vehicle where the road is wet
- The approaching vehicle is very fast or very slow

*** NOTICE**

For more details on the precautions of the rear corner radars, refer to "Blind-Spot Collision-Avoidance Assist (BCA) (if equipped)" on page 6-31.

⚠ WARNING

- Safe Exit Warning may not operate normally if interfered by strong electromagnetic waves.
- Safe Exit Warning may not operate for approximately 3 seconds after the vehicle is restarted, or the rear corner radars are initialized.
- Even after starting the vehicle again, Safe Exit Warning not function properly when the obstruction or malfunction condition persists.

This device complies with Industry Canada licence-exempt RSS standard(s).

Operation is subject to the following two conditions:

1. This device may not cause interference, and
2. This device must accept any interference, including interference that may cause undesired operation of the device.

Manual Speed Limit Assist (MSLA)

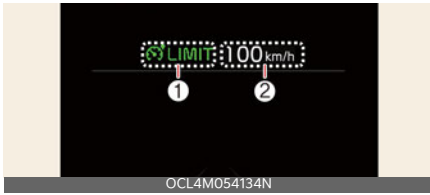

- 1 Speed Limit indicator
- 2 Set speed

You can set the speed limit when you do not want to drive over a specific speed. If you drive over the preset speed limit, Manual Speed Limit Assist operates (set speed limit will blink and chime will sound) until the vehicle speed returns within the speed limit.

Manual Speed Limit Assist operation

Setting speed limit

1. Press and hold Driving Assist button (Ⓜ) at the desired speed. The Speed Limit indicator (LIMIT) will appear on the cluster.



2. Push the (+) switch up or (-) switch down, and release it at the desired speed.

Push the (+) switch up or (-) switch down and hold it. The speed will increase or decrease to by multiple of 10km/h (5 mph).



3. The set speed limit will be displayed on the cluster.

If you would like to drive over the pre-set speed limit, depress the accelerator pedal.

The set speed limit will blink and chime will sound until you return the vehicle speed within the speed limit.

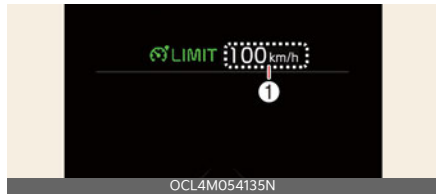

* NOTICE

To drive faster than the set speed limit, press the accelerator pedal deeply until the kickdown function activates.

Temporarily pausing Manual Speed Limit Assist



Press the (⏸) switch to temporarily pause the set speed limit. The set speed limit will turn off but the Speed Limit indicator (LIMIT) will stay on.

Resuming Manual Speed Limit Assist



To resume Manual Speed Limit Assist after the function was paused, operate the (+), (-), (||◁) switch.

If you push the (+) switch up or (-) switch down, vehicle speed will be set to the current speed on the cluster.

If you press the (||◁) switch, vehicle speed will resume to the preset speed.

Turning off Manual Speed Limit Assist



Press the Driving Assist button (🚗) to turn Manual Speed Limit Assist off. The Speed Limit indicator (SPEED LIMIT) will go off.

⚠ WARNING

Take the following precautions when using Manual Speed Limit Assist:

- Always set the vehicle speed under the speed limit in your country.
- Keep Manual Speed Limit Assist off when the function is not in use, to avoid inadvertently setting a speed. Check that the Speed Limit indicator (SPEED LIMIT) is off.

- Manual Speed Limit Assist does not substitute for proper and safe driving. It is the responsibility of the driver to always drive safely and should always be aware of unexpected and sudden situations from occurring. Pay attention to the road conditions at all times.

Intelligent Speed Limit Assist (ISLA)

Intelligent Speed Limit Assist uses information from the detected road signs and uses the navigation system data to inform you of the speed limit and to help maintain within the speed limit on the road.

CAUTION

- Intelligent Speed Limit Assist may not operate properly if the function is used in other countries.
- If a navigation is applied to your vehicle, the navigation needs to be regularly updated for Intelligent Speed Limit Assist to operate properly.

Detecting sensor

Front view camera



Front view camera (GT-Line)



Refer to the picture above for the detailed location of the detecting sensor.

CAUTION

For more details on the precautions of the front view camera, refer to "Forward

Collision-Avoidance Assist (FCA) (Sensor Fusion) (if equipped)" on page 6-4.

Intelligent Speed Limit Assist settings

Speed Limit

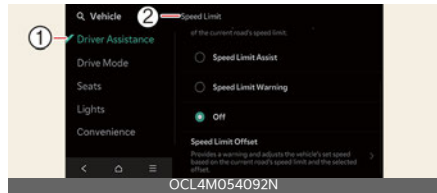

1 Driver Assistance

2 Speed Limit

With the vehicle on, select **Setup** → **Vehicle** → **Driver Assistance** → **Speed Limit** on the infotainment system.

- **Country Selection:** If navigation is not enabled, you can manually select the country from the menu. Please select the country you are currently driving in for proper functionality.
- **Speed Limit Assist:** Intelligent Speed Limit Assist will inform the driver of speed limit and additional road signs, and warn the driver when the vehicle is driven faster than the speed limit. In addition, Intelligent Speed Limit Assist will inform the driver to change set speed of Manual Speed Limit Assist or Smart Cruise Control to help the driver stay within the speed limit.
- **Speed Limit Warning:** Intelligent Speed Limit Assist will inform the driver of speed limit and additional road signs. In addition, Intelligent Speed Limit Assist will warn the driver when the vehicle is driven faster than the speed limit.
- **Off:** Intelligent Speed Limit Assist will turn off.

- **Speed Limit Offset:** The offset for Speed limit can be adjusted. The vehicle will warn the speed limit or adjust the driving speed when the current driving speed is higher than the recognized speed limit added with set tolerance value.

WARNING

Be sure to park in a safe place before setting Intelligent Speed Limit Assist.

*** NOTICE**

- Speed limit and Speed warning function operates based on an offset value added with the speed limit. Set the offset value to '0' to change or warn the speed according to the recognized speed limit.
- The setting of Speed limit offset is not reflected in Navigation-based Smart Cruise Control.

Intelligent Speed Limit Assist operation

Warning and control

Intelligent Speed Limit Assist is warned and controlled by the following level.

- Displaying speed limit
- Speeding warning
- Changing set speed
- Auto set speed change

*** NOTICE**

- Intelligent Speed Limit Assist warning and control are described based on the Offset adjust to '0'. For details on Offset setting, refer to "Intelligent Speed Limit Assist settings" on page 6-46.

Displaying speed limit



Speed limit information is displayed on the instrument cluster.

*** NOTICE**

- If speed limit information of the road cannot be recognized, '---' sign will be displayed. Please refer to "Intelligent Speed Limit Assist malfunction and limitations" on page 6-49 if the road signs are difficult to recognize.
- Intelligent Speed Limit Assist provides additional road sign information in addition to speed limit. The additional road sign information provided may vary according to your country.
- The images and colors in the instrument cluster may differ depending on the cluster type or theme selected from the settings menu.

Speeding warning

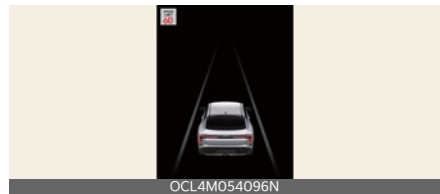

When driving at a speed higher than the displayed speed limit, the red speed limit indicator will be indicated.

Changing set speed



If the speed limit of the road changes during the operation of Manual Speed Limit Assist or Smart Cruise Control, an arrow in the direction of up or down is displayed to inform the driver that the set speed needs to be changed. At this time, the driver can change the set speed according to the speed limit by using the (+) or (-) switch on the steering wheel.

Auto set speed change (if equipped with the navigation)



When operating Manual Speed Limit Assist or Smart Cruise Control, if the speed set by the driver is the same as the speed limit on the road, the set speed is automatically adjusted accordingly the speed limit afterwards. The auto set speed change function operates on roads with a speed limit of above 70 km/h (45 mph). When the function is

activated, the set speed on the instrument cluster is displayed in green.

WARNING

- When driving at a speed lower than the speed limit, set the offset under '0', or press (-) switch to decrease your set speed.
- Even after changing the set speed according to the speed limit of the road, the vehicle can still be driven over the speed limit. If necessary, depress the brake pedal to reduce your driving speed.
- If the speed limit of the road is under 30 km/h (20 mph), the set speed change function will not work.
- Intelligent Speed Limit Assist operates using the speed unit in the instrument cluster set by the driver. If the speed unit is set to a unit other than the speed unit used in your country, Intelligent Speed Limit Assist may not operate properly.

*** NOTICE**

- For more details on Manual Speed Limit Assist operation, refer to "Manual Speed Limit Assist (MSLA)" on page 6-44.
- For more details on Smart Cruise Control operation, refer to "Smart Cruise Control (SCC) (if equipped)" on page 6-57.

Intelligent Speed Limit Assist malfunction and limitations

Intelligent Speed Limit Assist malfunction

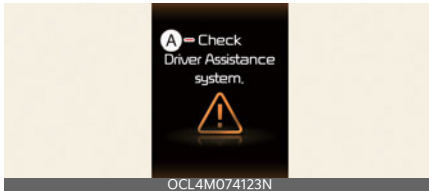

A: Check Driver Assistance system.

When Intelligent Speed Limit Assist is not working properly, the warning message will appear on the cluster for several seconds and the Master warning light (⚠) and the Intelligent Speed Limit Assist indicator light (⊞) will appear on the cluster.

If this occurs, have the vehicle inspected by an authorized Kia dealer.

Intelligent Speed Limit Assist disabled

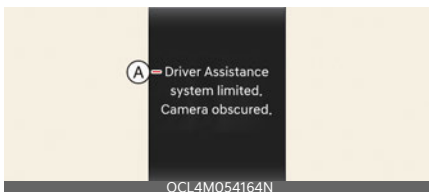

A: Driver Assistance system limited. Camera obscured.

When the windshield where the front view camera is located is covered with foreign material, such as snow or rain, it can reduce the detecting performance and temporarily limit or disable Intelligent Speed Limit Assist. If this occurs, the warning message and the Intelligent Speed Limit Assist indicator light (⊞) will appear on the cluster.

Intelligent Speed Limit Assist will operate properly when snow, rain or foreign material is removed. Always keep it clean.

If Intelligent Speed Limit Assist does not operate properly after it is removed, have the vehicle inspected by an authorized Kia dealer.

⚠ WARNING

- Even though the warning message or warning light does not appear on the cluster, Intelligent Speed Limit Assist may not operate properly.
- Even if restarting the vehicle with the sensors blocked or malfunctioned, Intelligent Speed Limit Assist may not properly operate as the function maintains the broken/covered state.

* NOTICE

You can check it in the service message of the utility information view of the cluster display window.

Limitations of Intelligent Speed Limit Assist

Intelligent Speed Limit Assist may not operate properly, or it may operate unexpectedly under the following circumstances:

- The road sign is contaminated or indistinguishable
 - The road sign is difficult to see due to bad weather, such as rain, snow, fog.
 - The road sign is partially obscured by surrounding objects or shadow
- The road signs do not conform to the standard
 - The text or picture on the road sign is different from the standard

- The road sign is installed between the main line and the exit road or between diverging roads
- A sign is attached to another vehicle
- The distance between the vehicle and the road signs is far
- The vehicle encounters illuminating road signs
- Intelligent Speed Limit Assist incorrectly recognizes numbers or pictures in the street signs or other signs as the speed limit
- A road sign near the road you are driving is detected
- Multiple signs are installed close together
- The minimum speed limit sign is mis-recognized
- The minimum speed limit sign is on the road
- The brightness changes suddenly, for example when entering or exiting a tunnel or passing under a bridge
- Headlamps are not used or the brightness of the headlamps are weak at night or in the tunnel
- The field of view of the front view camera is obstructed by sun glare
- Road signs are difficult to recognize due to the reflection of sunlight, streetlights, or oncoming vehicles
- The navigation information or GPS information contains errors.
- The driver does not follow the guide of the navigation.
- Driving on a road that is sharply curved or continuously curved
- Driving through speed bumps, or driving up and down or left to right on steep inclines

- The vehicle is shaking heavily
- Driving on a new road
- When driving on a road under construction.
- When the navigation software updates during driving

WARNING

- Intelligent Speed Limit Assist is a supplemental function that helps the driver to comply with the speed limit on the road, and may not display the correct speed limit or control the driving speed properly.
- It is the responsibility of the driver to keep the speed limit.
- It may not operate for 15 seconds after the vehicle is started, or the front view camera is initialized or restarted.

NOTICE

For more details on the limitations of the front view camera, refer to "Forward Collision-Avoidance Assist (FCA) (Sensor Fusion) (if equipped)" on page 6-4.

Driver Attention Warning (DAW)

Inattentive Driving Warning function

Driver Attention Warning monitors your driving pattern while driving. When the driver's attention level is below a certain level, Driver Attention Warning recommends a break to help with safe driving.

Leading Vehicle Departure Alert function

Leading Vehicle Departure Alert function will inform the driver when a detected vehicle in front departs from a stop.

Detecting sensor

Front view camera



Front view camera (GT-Line)



The front view camera is used as a detecting sensor to help detect driving patterns and front vehicle departure while vehicle is being driven. Refer to the picture above for the detailed location of the detecting sensor.

CAUTION

- Always keep the front view camera in good condition to maintain optimal performance of Driver Attention Warning.
- For more details on the precautions of the front view camera, refer to "Forward Collision-Avoidance Assist (FCA) (Sensor Fusion) (if equipped)" on page 6-4.

Driver Attention Warning settings

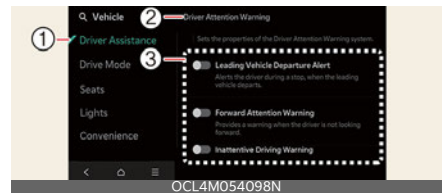

1 Driver Assistance

2 Driver Attention Warning

3 Leading Vehicle Departure Alert

With the vehicle on, select **Setup** → **Vehicle** → **Driver Assistance** → **Driver Attention Warning** → **Leading Vehicle Departure Alert** on the infotainment system.

- **Leading Vehicle Departure Alert:** Driver Attention Warning will inform the driver when a detected vehicle in front departs from a stop.
- **Inattentive Driving Warning:** Enables the Inattentive driving warning

Driver Attention Warning operation

Inattentive Driving Warning function

The basic function of Driver Attention Warning is as follows.

- Taking a break

Taking a break



A: Consider taking a break

The Inattentive Driving Warning light (A) blinking and warning message will appear on the cluster and an audible warning will sound to suggest that the driver take a break, when the driver's attention level is below a certain level.

- Driver Attention Warning will not suggest a break when the total driving time is shorter than 4 minutes or 4 minutes has not passed after the last break was suggested.

⚠ WARNING

For your safety, change the Settings after parking the vehicle at a safe location.

⚠ CAUTION

- Driver Attention Warning may suggest a break depending on the driver's driving pattern or habits, even if the driver doesn't feel fatigued.
- Driver Attention Warning is a supplemental function and may not be able to determine whether the driver is inattentive.
- The driver who feels fatigued should take a break at a safe location, even though there is no break suggestion by Driver Attention Warning.

Leading Vehicle Departure Alert function

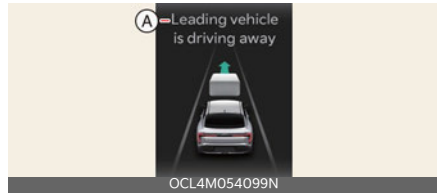

A: Leading vehicle is driving away

When a detected vehicle in front departs from a stop, Leading Vehicle Departure Alert will inform the driver by displaying the warning message on the cluster and an audible warning will sound.

⚠ WARNING

- If any other function's warning message is displayed or audible warning is generated, Leading Vehicle Departure Alert's warning message may not be displayed and audible warning may not be generated.
- The driver should hold the responsibility to safely drive and control the vehicle.

⚠ CAUTION

- Leading Vehicle Departure Alert is a supplemental function and may not alert the driver whenever the front vehicle departs from a stop.
- Always check the front of the vehicle and road conditions before departure.

* NOTICE

The images and colors in the instrument cluster may differ depending on the cluster type or theme selected from the settings menu.

Driver Attention Warning malfunction and limitations

Driver Attention Warning malfunction

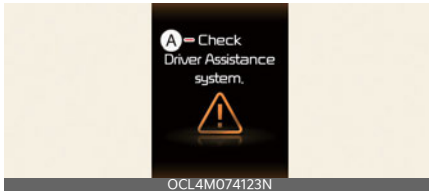

A: Check Driver Assistance system.

When Driver Attention Warning is not working properly, the warning message will appear on the cluster for several seconds, and the Master warning light (⚠) will appear on the cluster.

If this occurs, have the vehicle inspected by an authorized Kia dealer.

Driver Attention Warning disabled

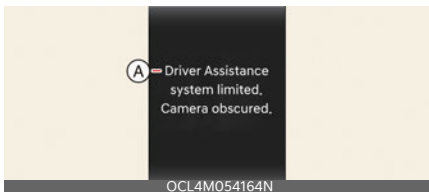

A: Driver Assistance system limited. Camera obscured.

When the windshield where the front view camera is located, or sensor is covered with foreign material, such as snow or rain, it can reduce the detecting performance and temporarily limit or disable Driver Attention Warning.

If this occurs the warning message, and the Master warning light (⚠) will appear on the cluster. This is normal operation.

Driver Attention Warning will operate properly when snow, rain or foreign material is removed.

If Driver Attention Warning does not operate properly after obstruction (snow, rain, or foreign material) is removed (including trailer, carrier, etc. from the rear bumper), have the vehicle inspected by an authorized Kia dealer.

⚠ WARNING

- Even though the warning message or warning light does not appear on the cluster, Driver Attention Warning may not properly operate.
- Driver Attention Warning may not properly operate in an area (e.g. open terrain), where there is nothing to detect, or detecting sensor is covered in foreign material after turning ON the vehicle.

* NOTICE

You can check it in the service message of the utility information view of the cluster display window.

Limitations of Driver Attention Warning

Driver Attention Warning may not work properly in the following situations:

- The vehicle is driven violently
- The vehicle intentionally crosses over lanes frequently
- The vehicle is controlled by Driver Assistance system, such as Lane Keeping Assist
- When the lane markings are blurred or erased

Leading vehicle departure alert function

- When the vehicle cuts in

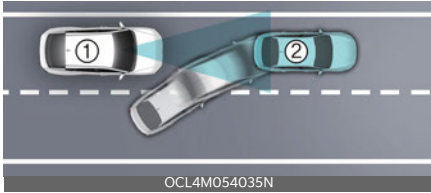
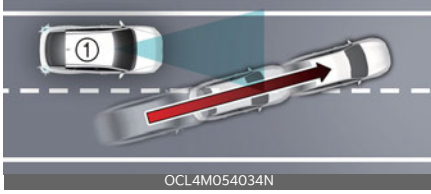

1. Your vehicle
2. Front vehicle

If a vehicle cuts in front of your vehicle, Leading Departure Alert may not operate properly.

- When the vehicle ahead sharply steers



1. Your vehicle
2. Front vehicle

If the vehicle in front makes a sharp turning, such as to turn left or right or making a U-turn, etc., Leading Vehicle Departure Alert may not operate properly.

- When the vehicle ahead abruptly departs



If the vehicle in front abruptly departs, Leading Vehicle Departure Alert may not operate properly.

- When a pedestrian or bicycle is between you and the vehicle ahead



If there is a pedestrian(s) or bicycle(s) in between you and the vehicle in front, Leading Vehicle Departure Alert may not operate properly.

- When in a parking lot

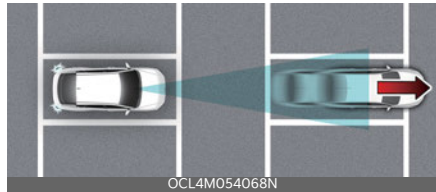

If a vehicle parked in front drives away from you, Leading Vehicle Departure Alert may alert you that the parked vehicle is driving away.

- When driving at a tollgate or intersection

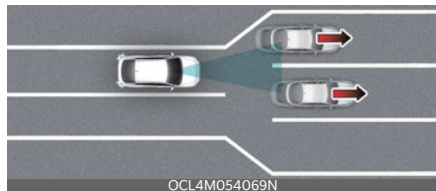

If you pass a tollgate or intersection with lots of vehicles or you drive where lanes are merged or divided frequently, Leading Vehicle Departure Alert may not operate properly.

WARNING

Driver Attention Warning may not operate for 15 seconds after the vehicle is started, or the front view camera is initialized.

*** NOTICE**

For more details on the precautions of the front view camera, refer to "Forward Collision-Avoidance Assist (FCA) (Sensor Fusion) (if equipped)" on page 6-4.

Blind-Spot View Monitor (BVM) (if equipped)

Left



Right



Blind-Spot View Monitor displays the rear blind spot area of the vehicle in the cluster when the turn signal is turned on to help safely change lanes.

6

Detecting sensor

Wide-side view camera/Outside rear view mirror



Blind-Spot View Monitor settings

Blind-Spot View Monitor



1 Driver Assistance

2 Driving Safety

3 Blind-Spot View Monitor

With the vehicle on, select **Setup** → **Vehicle** → **Driver Assistance** → **Driving Safety** → **Blind-Spot View Monitor** from the infotainment system screen to turn on Blind-Spot View Monitor and deselect to turn off the function.

Blind-Spot View Monitor operation

Turn signal lever



Blind-Spot View Monitor will turn on and off when the turn signal is turned on and off.

Blind-Spot View Monitor

Operating conditions

- When the left or right turn signal turns on, the image on the instrument cluster will turn on.

Off conditions

Blind-Spot View Monitor will turn off when one of the following conditions are satisfied:

- When the turn signal is turned off.
- When the hazard warning flasher is on.
- When other important warning is displayed on the instrument cluster.

Blind-Spot View Monitor malfunction

When Blind-Spot View Monitor is not working properly, or the cluster display flickers, or the camera image does not display normally, have the vehicle inspected by an authorized Kia dealer.

WARNING

- Blind-Spot View Monitor may display objects at a different distance from what is shown on the screen due to the correction of the wide-side view camera images. Make sure to directly check the vehicle's surroundings for safety.
- If the camera lens is covered with foreign material, Blind-Spot View Monitor may not operate normally. Always keep the camera lens clean. However, do not use chemical solvents such as strong detergents containing high alkaline or volatile organic solvents (gasoline, acetone etc.). This may damage the camera lens.

Smart Cruise Control (SCC) (if equipped)

Basic function

Smart Cruise Control detects a vehicle ahead and can help maintain the distance from the vehicle ahead and the set speed.

Overtake Acceleration Assist function

When Smart Cruise Control judges you are attempting to overtake a vehicle in front, Smart Cruise Control helps with accelerating.

Based On Driving Style function (if equipped)

Smart Cruise Control will operate based on the driver's driving style, such as inter-vehicle distance, acceleration, reaction speed.

Detecting sensor

Front view camera



OCL4M054001N

Front view camera (GT-Line)



OCL4MGTL054001

Front radar



OCL4M054003N

Front radar (GT-Line)



OCL4MGTL054002

Front corner radar (if equipped)



OCL4M054004N

Front corner radar (GT-Line)



OCL4MGTL054003

Refer to the picture above for the detailed location of the detecting sensor.

⚠ CAUTION

- Always keep the front view camera and front radar in good condition to maintain optimal performance of Smart Cruise Control.
- For more details on the precautions of the front view camera and front radar, refer to "Forward Collision-Avoidance

Assist (FCA) (Sensor Fusion) (if equipped)" on page 6-4.

Smart Cruise Control settings

Smart Cruise Control

With the vehicle on, select **Setup** → **Vehicle** → **Driver Assistance** → **Driving Convenience** → **Smart Cruise Control** on the infotainment system to set the distance, acceleration and the reaction speed.

Based on driving style

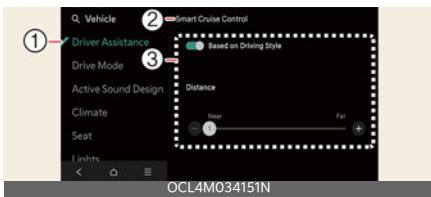

1 Driver Assistance

2 Smart Cruise Control

3 Based on Driving Style

With the vehicle on, if **Setup** → **Vehicle** → **Driver Assistance** → **Driving Convenience** → **Smart Cruise Control** → **Based on Driving Style** is selected from the infotainment system screen, Smart Cruise Control will operate based on the driver's driving style, such as vehicle distance, acceleration, reaction speed.

The driving style can be adjusted manually.

* NOTICE

- If equipped with Based on Driving Style, Based on driving mode and Based on driving style can be selected from the infotainment system screen by selecting **Setup** → **Vehicle** → **Driver Assistance** → **Smart Cruise Control**.

- While Smart Cruise Control is operating with Based on driving style selected, if you press and hold the Vehicle Distance button (⏸), based on driving mode will disabled. Press and hold the Vehicle Distance button (⏸) to change Smart Cruise Control to Based on driving style mode.
- Smart Cruise Control learns your driving styles only when drive the vehicle.
- When Based On Driving Style is disabled, your driving style (inter-vehicle distance, acceleration, response speed) remains at the same level as the Based On Driving Style.
- When the Based On Driving Style is enabled or disabled, the displayed driving style (including inter-vehicle distance, acceleration, and response speed) may vary between different controlled styles.

Warning Methods



1 Driver Assistance

2 Warning Methods

The **Warning Methods** can be set with the vehicle on. Select **Setup** → **Vehicle** → **Driver Assistance** → **Warning Methods** → **Warning Volume** from the settings menu in the infotainment system to change the following settings:

- **Warning Volume:** Adjusts the volume of the warning sound. If you turn off the **Warning Volume**, for your safety, the function may warn you with a low volume.

- **Haptic Warning:** Activate the steering wheel vibration warning.
- **Driving Safety Priority:** Lowers all other audio volumes when the Driving Safety system sounds a warning.

* INFORMATION

- Ensure that **Warning Methods** you have set may apply to the **Warning Methods** of other driver assistance systems.
- **Warning Methods** will maintain its last setting even if the vehicle is restarted.
- The setting menu may not be available for your vehicle depending on the vehicle features and specifications.
- The **Warning Volume** and **Haptic Warning** cannot be turned off at the same time. When one of the warnings is turned off another is activated.

Smart Cruise Control operation

Operating conditions

Basic function

Smart Cruise Control operates when the following conditions are satisfied.

- The gear is in D (Drive)
- Your driving speed is within the operating speed range
 - 10~180 km/h (5~110 mph): when there is no vehicle in front
 - 0~180 km/h (0~110 mph): when there is a vehicle in front
- ESC (Electronic Stability Control) or ABS is on

Smart Cruise Control does not operate in the following conditions.

- The driver's door is open

- Engine RPM is high
- EPB (Electronic Parking Brake) is applied
- ESC (Electronic Stability Control) or ABS is controlling the vehicle
- Forward Collision-Avoidance Assist brake control is operating

* NOTICE

When stopped behind another vehicle, you can turn on Smart Cruise Control while the brake pedal is depressed.

Overtake Acceleration Assist function

Overtaking Acceleration Assist will operate when the turn signal indicator is turned on to the left (left-hand drive) or turned on to the right (right-hand drive) while Smart Cruise Control is operating, and the following conditions are satisfied:

- Your driving speed is above 60 km/h (40 mph)
 - A vehicle is detected in front of you
- Overtaking Acceleration Assist does not operate in the following conditions.
- The hazard warning flasher is on
 - Vehicle speed is reduced to maintain distance with a vehicle in front

⚠ WARNING

- When the turn signal indicator is turned on to the left (left-hand drive) or turned on to the right (right-hand drive) while there is a vehicle ahead, the vehicle may accelerate temporarily. Always pay attention to the road conditions.
- Regardless of your country's driving direction, Overtaking Acceleration Assist will operate when the condi-

tions are satisfied. When using the function in countries with different driving direction, always check the road conditions.

Turning on Smart Cruise Control



Press the Driving Assist button to turn on Smart Cruise Control. The speed will be set to the current speed on the cluster.

- If there is no vehicle in front of you, the set speed will be maintained.
- If there is a vehicle in front of you, the speed may be adjusted to maintain the distance to the vehicle ahead. If the vehicle ahead accelerates, your vehicle will travel at a steady cruising speed after accelerating to the set speed.

* NOTICE

If your vehicle speed is between 0~30 km/h (0~20 mph) when you press the Driving Assist button, the Smart Cruise Control speed will be set to 30 km/h (20 mph).

Setting vehicle distance



Each time the button is pressed, the headway changes as follows:

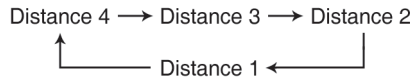

For example, if you drive at 90 km/h (56 mph), the distance is maintained as follows:

- Distance 4: approximately 52.5 m (172 ft)
- Distance 3: approximately 40 m (130 ft)
- Distance 2: approximately 32.5 m (106 ft)
- Distance 1: approximately 25 m (82 ft)

* NOTICE

The distance is set to the last set distance when the vehicle is restarted, or when Smart Cruise Control was temporarily canceled.

Increasing set speed



- Push the (+) switch up and release it immediately. The set speed will increase by 1 km/h (1 mph) each time the switch is operated in this manner.
- Push the (+) switch up and hold it. The set speed will increase by 10 km/h (5 mph) each time the switch is operated in this manner.

You can increase the set speed to 180 km/h (110 mph).

⚠ WARNING

Check the driving condition before using the (+) switch. Driving speed may sharply increase when you push up and hold the (+) switch.

Decreasing set speed



- Push the (-) switch down and release it immediately. The set speed will decrease by 1 km/h (1 mph) each time the switch is operated in this manner.
- Push the (-) switch down and hold it. The set speed will decrease by 10 km/h (5 mph) each time the switch is operated in this manner.
You can decrease the set speed to 30 km/h (20 mph).

Temporarily canceling Smart Cruise Control



Press the (||>) switch or depress the brake pedal to temporarily cancel Smart Cruise Control.

Resuming Smart Cruise Control

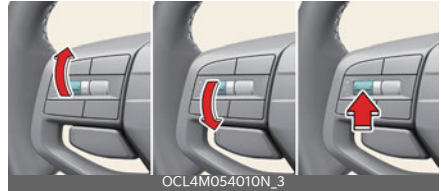

To resume Smart Cruise Control after the function was canceled, operate the (+), (-) or (||>) switch.

If you push the (+) switch up or (-) switch down, the set speed will be set to the current speed on the cluster.

If you press the (||>) switch, vehicle speed will resume to the preset speed.

⚠ WARNING

Check the driving condition before using the (||>) switch. Driving speed may sharply increase or decrease when you press the (||>) switch.

Turning off Smart Cruise Control



Press the Driving Assist button to turn Smart Cruise Control off.

*** NOTICE**

If your vehicle is equipped with Manual Speed Limit Assist, press and hold the Driving Assist button to turn off Smart Cruise Control. However, Manual Speed Limit Assist will turn on.

⚠ WARNING

Do not use the switches and buttons at the same time. Smart Cruise Control may not operate properly.

Smart Cruise Control display and control

You can see the status of the Smart Cruise Control operation in the Driving Assist view on the instrument cluster. Refer to "LCD display modes" on page 4-67.

Smart Cruise Control will be displayed as below depending on the status of the function.

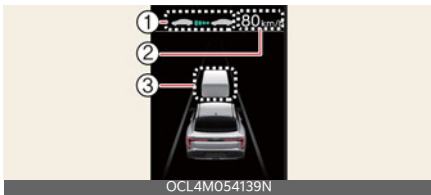

Smart Cruise Control will be displayed as below depending on the status of the function.

- When operating
 1. Whether there is a vehicle ahead and the selected distance level
 2. The set speed
 3. Whether there is a vehicle ahead and the target vehicle distance
- When temporarily canceled
 1. Your vehicle (gray)
 2. Previous set speed (gray)
 3. Whether there is a vehicle ahead (gray) (if equipped)

*** NOTICE**

- The distance of the front vehicle on the instrument cluster is displayed according to the actual distance

between your vehicle and the vehicle ahead.

- The target distance may vary according to the vehicle speed and the set distance level. If vehicle speed is low, even though the vehicle distance has changed, the change of the target vehicle distance may be small.
- The images or colors displayed on the cluster may vary depending on the instrument cluster specifications or themes.

Accelerating temporarily

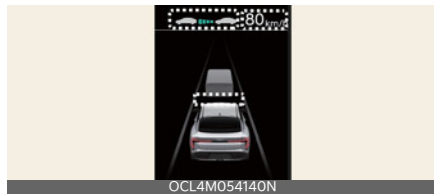

If you want to speed up temporarily without altering the set speed while Smart Cruise Control is operating, depress the accelerator pedal. While the accelerator pedal is depressed, the set speed, distance level and target distance will blink on the instrument cluster. However, if the accelerator pedal is depressed insufficiently, the vehicle may decelerate.

⚠ WARNING

Be careful when accelerating temporarily as, because the speed and distance is not controlled automatically even if there is a vehicle in front of you.

Based on Driving Style operating



When the Based on Driving Style is enabled, the instrument cluster will show the set vehicle distance level and target vehicle distance in white. It will also display the distance level and target distance based on your driving behavior.

Smart Cruise Control will be temporarily canceled automatically when:

- Your driving speed is above 190 km/h (120 mph)
- The vehicle is stopped for a certain period
- The accelerator pedal is continuously depressed for a certain period
- The conditions for the Smart Cruise Control to operate are not satisfied

* NOTICE

If Smart Cruise Control is temporarily canceled while the vehicle is at a standstill with the function activated, EPB (Electronic Parking Brake) maybe applied.

▲ WARNING

When Smart Cruise Control is temporarily canceled, the distance to a vehicle in front will not be maintained. Always have your eyes on the road and, if necessary, depress the brake pedal to reduce your speed to maintain a safe distance.

Temporarily canceling Smart Cruise Control

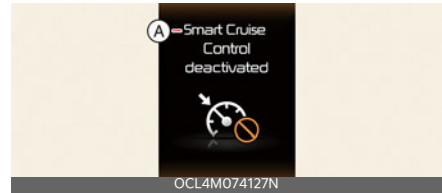

A: Smart Cruise Control deactivated

If Smart Cruise Control is temporarily canceled automatically, a warning message will appear on the instrument cluster, and an audible warning will sound to warn the driver.

Smart Cruise Control conditions not satisfied

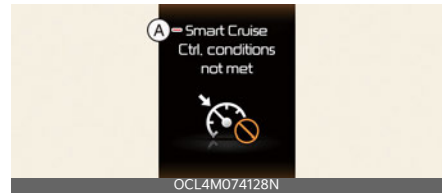

A: Smart Cruise Ctrl. conditions not met

If the Driving Assist button, (+) switch, (-) switch or (⏏) switch is operated when Smart Cruise Control operating conditions are not satisfied, a warning message will appear on the instrument cluster and an audible warning will sound.

In traffic situation

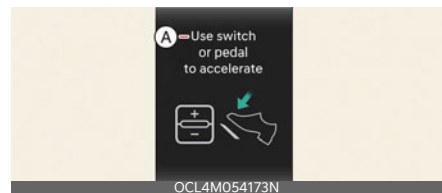

A: Use switch or pedal to accelerate

In traffic, your vehicle will stop if the vehicle ahead of you stops. If the vehicle ahead starts moving, your vehicle will start as well.

After the vehicle has stopped and a certain time has passed, a warning message will appear on the instrument cluster. Depress the accelerator pedal or operate the (+) switch, (-) switch or (||◁) switch to start driving.

Warning road conditions ahead

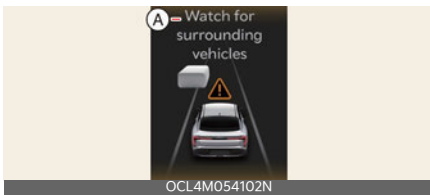

A: Watch for surrounding vehicles

In the following situation, a warning message will appear on the instrument cluster, and an audible warning will sound to warn the driver of road conditions ahead.

⚠ WARNING

Always pay attention to vehicles or objects that may suddenly appear in front of you, and if necessary, depress the brake pedal to reduce your speed to maintain a safe distance.

Collision Warning

When Smart Cruise Control detects a risk of collision with the vehicle ahead, operating Forward Collision-Avoidance Assist may increase the risk of an accident.

Pay attention to road and driving conditions immediately, and if necessary, depress the brake pedal to reduce your driving speed.

For more details on this function, refer to "Forward Collision-Avoidance Assist (FCA) (Sensor Fusion) (if equipped)" on page 6-4

⚠ WARNING

- Smart Cruise Control does not substitute for proper and safe driving. It is your responsibility to always check the speed and distance to a vehicle ahead.
- Smart Cruise Control may not recognize unexpected, sudden or complex situations, so always pay attention to driving conditions and control your vehicle speed.
- Keep Smart Cruise Control off when the function is not in use to avoid inadvertently setting a speed.
- Do not open the door or leave the vehicle when Smart Cruise Control is operating, even if the vehicle is stopped.
- Always be aware of the selected speed and distance ahead.
- Keep a safe distance according to road conditions and vehicle speed. If the distance is too close when driving at high speed, a serious collision may result.
- When maintaining distance with a vehicle ahead, if that vehicle disappears from view, Smart Cruise Control may suddenly accelerate to the set speed. Always be aware of unexpected and sudden situations.
- Vehicle speed may decrease on an upward slope and increase on a downward slope.
- Always be aware of emergent situations such as when a vehicle cuts in suddenly.

- When towing a trailer or something similar, your vehicle may experience frequent shifting and high RPM and the performance of Smart Cruise Control may be compromised. Always drive with caution.
 - Turn off Smart Cruise Control when your vehicle is being towed.
 - Smart Cruise Control may not operate properly if interfered with by strong electromagnetic waves.
 - Smart Cruise Control may not detect an obstacle in front and lead to a collision. Always look ahead to prevent unexpected and sudden situations from occurring.
 - Vehicles moving in front of you with frequent lane changes may cause a delay in Smart Cruise Control reaction or may cause Smart Cruise Control to react to a vehicle that is actually in an adjacent lane. Always drive cautiously to prevent unexpected and sudden situations from occurring.
 - Always be aware of the surroundings and drive safely, even though a warning message does not appear or an audible warning does not sound.
 - If any other function's warning message is displayed or warning sound is generated, Smart Cruise Control warning message may not be displayed and warning sound may not be heard.
 - You may not hear the warning sound of Forward Collision-Avoidance Assist if the surrounding is noisy.
 - The vehicle manufacturer is not responsible for any traffic violation or accident caused by the driver.
 - Always set the vehicle speed under the posted speed limit.
-
- If your driving style changes, distance, acceleration and reaction speed may change.
-
- ⚠ CAUTION**
- Your vehicle must be driven sufficiently to analyze your actual driving style, such as vehicle distance, acceleration and reaction speed.
 - Based on Driving Style may not reflect the driver's driving style or driving conditions which could affect driving safety.
 - If you are driving in special conditions, such as snow, rain, fog or steep hills, your vehicle may not be driven according to your driving style.
-
- * NOTICE**
- Smart Cruise Control may not operate for a few seconds after the vehicle is restarted or the front view camera or front radar is initialized.
 - You may hear a sound when the brake is controlled by Smart Cruise Control.
 - Based on Driving Style may not reflect your driving style if it's is not safe such as rapid acceleration.
 - Based on Driving Style does not reflect any driving style other than vehicle distance, acceleration and reaction speed.
-

Smart Cruise Control malfunction and limitations

Smart Cruise Control malfunction

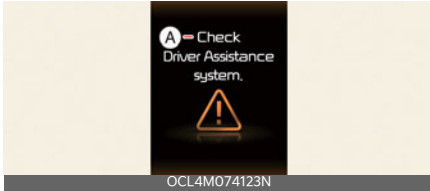

A: Check Driver Assistance system
 If there is a malfunction in Smart Cruise Control, a warning message will be displayed on the instrument cluster (and turned off after a certain period), and the Master warning light (⚠) will turn on. Have Smart Cruise Control inspected by an authorized Kia dealer.

Smart Cruise Control disabled

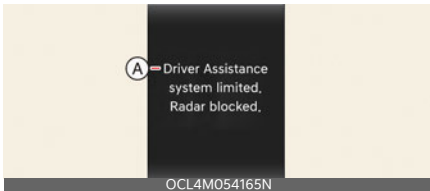

A: **Driver Assistance system limited. Radar blocked.**

When the front radar cover or sensor is covered with snow, rain, or foreign material, it can reduce the detecting performance and temporarily limit or disable Smart Cruise Control.

A warning messages and the Master warning light (⚠) are displayed on the instrument cluster (and turn off after a certain period). This does not indicate a malfunction of Smart Cruise Control. Smart Cruise Control will operate properly when snow, rain or foreign material is removed. Always keep it clean.

⚠ WARNING

Even though a warning message does not appear on the instrument cluster, Smart Cruise Control may not properly operate.

⚠ CAUTION

Smart Cruise Control may not properly operate in an open area where there is nothing to detect, or the detecting sensor is covered with foreign material after turning ON your vehicle.

* NOTICE

You can check it in the service message of the utility information view of the instrument cluster display window.

Limitations of Smart Cruise Control

Smart Cruise Control may not operate normally under the following circumstances:

- The detecting sensor or the surroundings are contaminated or damaged
- Washer fluid is continuously sprayed, or the wiper is on
- The camera lens is contaminated due to tinted, filmed or coated windshield, damaged glass, or sticky foreign material (sticker, bug, etc.) on the glass
- Moisture is not removed or frozen on the windshield
- The field of view of the front view camera is obstructed by sun glare
- Streetlights or light from an oncoming vehicle is reflected on a wet road.
- The temperature around the front view camera is high or low

- An object is placed on the instrument panel
- The surroundings are very bright
- The surroundings are very dark, such as in a tunnel, etc.
- The brightness changes suddenly, for example when entering or exiting a tunnel
- The brightness outside is low, and the headlight are not on or are not bright
- Driving in heavy rain, snow or thick fog
- Driving through steam, smoke or shadows
- Only part of a vehicle is detected
- A vehicle in front has no taillights, taillights are atypically located, etc.
- The brightness outside is low, and the taillights are not on or are not bright
- The rear of a front vehicle in front is small or does not look normal (for example, tilted, overturned, etc.)
- A front vehicle's ground clearance is low or high
- A vehicle suddenly cuts in front
- Your vehicle is being towed
- An object reflects off the front radar such as a guardrail, nearby vehicle, etc.
- The bumper around the front radar is impacted, damaged, or the front radar is out of position
- The temperature around the front radar is high or low
- The vehicle in front is made of material that does not reflect on the front radar
- Driving near a highway, interchange or tollgate
- Driving on a slippery surface due to snow, rain, ice, etc.
- Driving on a curved road
- A vehicle in front is detected late
- A vehicle in front is suddenly blocked by an obstacle
- A vehicle in front suddenly changes a lane or suddenly reduces speed
- A vehicle in front is bent out of shape
- A vehicle in front's speed is fast or slow
- With a vehicle in front, you change lane suddenly
- A vehicle in front is covered with snow
- Unstable driving
- You are on a roundabout (rotary) and a vehicle in front is not detected
- You are continuously driving in a circle
- Adverse road conditions cause excessive vehicle vibration
- Your vehicle height is low or high due to heavy loads, abnormal tire pressure, etc.
- Driving in the following places
 - Driving in a parking lot
 - Driving through a construction area, unpaved road, partially paved road, uneven road, speed bumps, etc.
 - Driving on an inclined road, curved road, etc.
 - Driving through a roadside with trees or streetlights
 - Driving through a narrow road with overgrown foliage
 - There is interference from electromagnetic waves, such as driving in an area with strong radio waves or electrical noise
 - Driving on a curved road
- Driving through a tunnel or on an iron bridge

- Driving near areas containing metal substances, such as a construction zone, railroad, etc.
- Driving in wide open areas where there are few vehicles or structures
 - Driving through steam, smoke, or shadow
 - Driving near a highway interchange or tollgate
- Driving on a curved road



On curves, Smart Cruise Control may not detect a vehicle in the same lane and may accelerate to the set speed. Vehicle speed may rapidly decrease when a vehicle ahead is detected suddenly.

Select the appropriate set speed on curves and apply the brake pedal or accelerator pedal according to the road and driving conditions ahead.



Your vehicle speed can reduce due to a vehicle in an adjacent lane.

Check that the road conditions permit safe operation of Smart Cruise Control and if necessary, depress the brake pedal to reduce your driving speed to maintain a safe distance

- Driving on an inclined road



During uphill or downhill driving, the Smart Cruise Control may not detect a moving vehicle in your lane and cause your vehicle to accelerate to the set speed. Vehicle speed will rapidly decrease when a vehicle ahead is detected suddenly.

Select the appropriate set speed on inclines and apply the brake pedal or accelerator pedal according to the road and driving conditions ahead.

- Changing lanes

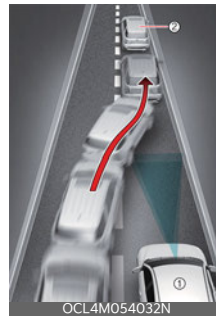

1. Your vehicle,
2. Lane changing vehicle

When a vehicle (2) moves into your lane from an adjacent lane, it cannot be detected by the sensor until it is in the sensor's detection range. Smart Cruise Control may not immediately detect the vehicle when the vehicle changes lanes abruptly. You must maintain a safe braking distance and, if necessary, depress the brake pedal to reduce your driving speed in order to maintain a safe distance.

- Detecting a vehicle



In the following cases, some vehicles in your lane cannot be detected by the sensor:

- Vehicles offset to one side
- Slow-moving vehicles or sudden-decelerating vehicles
- Vehicles with higher ground clearance or vehicles carrying loads that stick out of the back of the vehicle
- Vehicles that have the front lifted due to heavy loads
- Vehicles within approximately 2m (6 ft) from your vehicle
- Oncoming vehicles
- Stopped vehicles
- Vehicles with small rear profile, such as trailers
- Narrow vehicles, such as motorcycles or, bicycles
- Specialty vehicles
- Animals and pedestrians

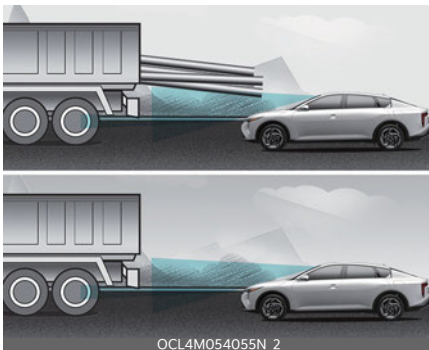

In the following cases, the vehicle in front cannot be detected by the sensor. Always pay attention to the road and driving conditions and drive safely. If necessary, adjust your vehicle speed.

- You are steering your vehicle
- Driving on narrow or sharply curved roads
- When a vehicle ahead disappears from view at an intersection



When a vehicle ahead disappears from view at an intersection, your vehicle may accelerate.

Always pay attention to road and driving conditions while driving.

- When a vehicle in front of you merges out of the lane



When a vehicle in front of you merges out of the lane, Smart Cruise Control may not immediately detect the new vehicle that is now in front of you.

Always pay attention to road and driving conditions while driving.

- Always look out for pedestrians

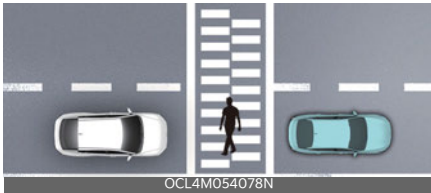

Always look out for pedestrians when your vehicle is maintaining a distance with the vehicle ahead.

This device complies with Industry Canada licence-exempt RSS standard(s).

Operation is subject to the following three conditions:

1. This device may not cause interference, and
2. This device must accept any interference, including interference that may cause undesired operation of the device.
3. Changes or modifications not expressly approved by the party responsible for compliance could void the user's authority to operate the device.

Navigation-based Smart Cruise Control (NSCC) (if equipped)

Navigation-based Smart Cruise Control helps maintain safe speed depending on the road conditions by using information from the navigation system when driving on highways while Smart Cruise Control is operating.

*** NOTICE**

- Navigation-based Smart Cruise Control is available only on controlled access road of certain highways (or motorways).
 - * Controlled access road indicates roads with limited entrances and exits that allow uninterrupted high speed traffic flow. Only passenger cars and motorcycles are allowed on controlled access roads.
- Navigation-based Smart Cruise Control operates on main roads of controlled access road, and does not operate on interchanges or junctions.
- Additional highways may be expanded by future navigation updates.

Highway Curve Zone Auto Slowdown

If vehicle speed is high, Highway Curve Zone Auto Slowdown function will temporarily decelerate your vehicle or limit acceleration to help you drive safely on a curve based on the curve information from the navigation.

⚠ WARNING

Navigation-based Smart Cruise Control (NSCC) is a supplemental system and is not a substitute for safe driving. It is the

responsibility of the driver to always check the speed and distance to the vehicle ahead. Always drive safely and use caution.

Navigation-based Smart Cruise Control settings

Highway Curve Zone Auto Slowdown



- 1 Driver Assistance
- 2 Driving Convenience
- 3 Highway Curve Zone Auto Slowdown

With the vehicle on, select **Setup** → **Vehicle** → **Driver Assistance** → **Highway Curve Zone Auto Slowdown** on the infotainment system.

* NOTICE

When there is a problem with Navigation-based Smart Cruise Control, the function cannot be set from the Settings menu.

Navigation-based Smart Cruise Control operation

Operating conditions

Navigation-based Smart Cruise Control is ready to operate if all the following conditions are satisfied:

- Set 'Highway Auto Speed Change' settings on the cluster/infotainment system screen.
- Smart Cruise Control is operating

- Driving on main roads of highways (or motorways)

* NOTICE

For more details on how to operate Smart Cruise Control, refer to "Smart Cruise Control (SCC) (if equipped)" on page 6-57.

Navigation-based Smart Cruise Control display

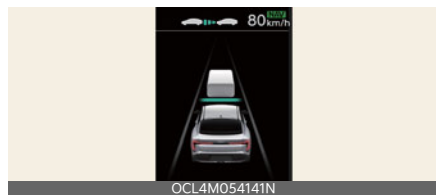

When Navigation-based Smart Cruise Control operates, it will be displayed on the cluster as follows:

Navigation-based Smart Cruise Control standby

If all the operating conditions are satisfied, the green (NAV) indicator will appear.

Navigation-based Smart Cruise Control operating

During speed control, the green (NAV) indicator will blink.

Navigation-based Smart Cruise Control pause/driver operation

If Smart Cruise Control cannot be operated due to pause or rerouting, the gray (NAV) indicator will appear on the cluster.

If the accelerator pedal is depressed, the white (NAV) indicator will blink on the cluster.

⚠ WARNING

The warning message will appear in the following circumstances:



A: Drive carefully

- Navigation-based Smart Cruise Control is not able to slow down your vehicle to a safe speed

*** NOTICE**

The images and colors in the instrument cluster may differ depending on the cluster type or theme selected from the settings menu.

Highway Curve Zone Auto Slow-down

Depending on the curve ahead on the highway (or motorway), the vehicle will decelerate, and after passing the curve, the vehicle will accelerate to Smart Cruise Control set speed.

*** NOTICE**

The starting point of deceleration depends on the vehicle's driving speed and the curvature of the road. The higher the driving speed, the earlier the deceleration start point.

Navigation-based Smart Cruise Control limitations

Navigation-based Smart Cruise Control may not operate normally under the following circumstances:

- The navigation is not working properly
- Speed limit and road information in the navigation is not updated
- Map information is not transmitted due to infotainment system's abnormal operation
- The map information and the actual road is different because of real-time GPS data or map information error
- The navigation searches for a route while driving
- GPS signals are blocked in areas such as a tunnel
- A road that divides into two or more roads and joins again
- The driver goes off course the route set in the navigation
- The route to the destination is changed or canceled by resetting the navigation
- The vehicle enters a service station or rest area
- Android Auto or CarPlay is operating
- The navigation cannot detect the current vehicle position (for example, elevated roads, including overpassing adjacent to general roads or nearby roads exist in a parallel way)
- The navigation is being updated while driving
- The navigation is being restarted while driving
- The speed limit of some sections changes according to the road situations
- Driving on a road under construction
- Driving on a road that is controlled
- There is bad weather, such as heavy rain and heavy snow.

- Driving on a road that is sharply curved

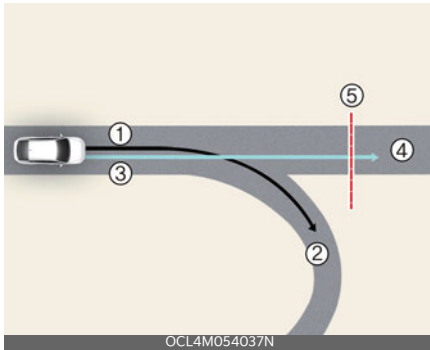

- 1 Set route
- 2 Branch line
- 3 Driving route
- 4 Main road
- 5 Curved road section

- When there is a difference between the navigation set route (branch line) and the driving route (main road), Highway Curve Zone Auto Slowdown function may not operate until the driving route is recognized as the main road.
- When the vehicle's driving route is recognized as the main road by maintaining the main road instead of the navigation set route, Highway Curve Zone Auto Slowdown function will operate. Depending on the distance to the curve and the current vehicle speed, vehicle deceleration may not be sufficient or may decelerate rapidly.

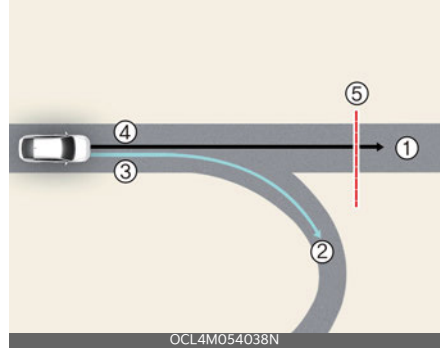

- 1 Main road
- 2 Branch line
- 3 Driving route
- 4 Set route
- 5 Curved road section

- When there is a difference between the navigation set route (main road) and the driving route (branch line), Highway Curve Zone Auto Slowdown function will operate temporarily based on the curve information on the main road.
- When it is judged that you are driving out of the route by entering the highway interchange or junction, Highway Curve Zone Auto Slowdown function will not operate.

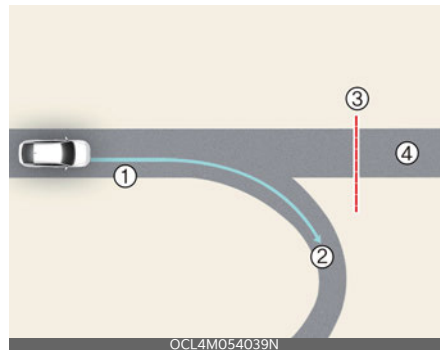

- 1 Driving route

- 2 Branch line
- 3 Curved road section
- 4 Main road

- If there is no destination set on the navigation, Highway Curve Zone Auto Slowdown function will operate based on the curve information on the main road.
- Even if you depart from the main road, Highway Curve Zone Auto Slowdown function may temporarily operate due to navigation information of the highway curve section.

WARNING

- Navigation-based Smart Cruise Control is not a substitute for safe driving practices, but a convenience function. Always have your eyes on the road, and it is the responsibility of the driver to avoid violating traffic laws.
- The navigation's speed limit information may differ from the actual speed limit information on the road. It is the driver's responsibility to check the speed limit on the actual driving road or lane.
- Highway Curve Zone Auto Slowdown function will automatically be canceled when you leave the highway (or motorway) main road to enter the normal road or the area (interchange, junction, rest area, etc.).
- Navigation-based Smart Cruise Control may not operate due to the existence of leading vehicles and the driving conditions of the vehicle. Always pay attention to road and driving conditions while driving.
- When towing a trailer or something similar, the vehicle's deceleration may not be sufficient. Always drive with caution.

- After you pass through a tollgate on a highway (or motorway), Navigation-based Smart Cruise Control will operate based on the first lane. If you enter one of the other lanes, Navigation-based Smart Cruise Control might not operate properly.
- The vehicle will accelerate if the driver depresses the accelerator pedal while Navigation-based Smart Cruise Control is operating, and the function will not decelerate the vehicle. However, if the accelerator pedal is depressed insufficiently, the vehicle may decelerate.
- If the driver accelerates and releases the accelerator pedal while Navigation-based Smart Cruise Control is operating, the vehicle may not decelerate sufficiently or may rapidly decelerate to a safe speed.
- If the curve is too large or too small, Navigation-based Smart Cruise Control may not operate.

NOTICE

- A time gap could occur between the navigation's guidance and when Navigation-based Smart Cruise Control operation starts and ends.
- The speed information on the cluster and navigation may differ.
- Even if you are driving at a speed lower than Smart Cruise Control set speed, acceleration may be limited by the curve sections ahead.
- If Navigation-based Smart Cruise Control is operating while leaving the main road to enter an interchange, junction, rest area, etc., the function may operate for a certain period of time.

- Deceleration by Navigation-based Smart Cruise Control may feel it is not sufficient due to road conditions such as uneven road surfaces and narrow lanes.

This device complies with Industry Canada licence-exempt RSS standard(s).

Operation is subject to the following three conditions:

1. This device may not cause interference, and
2. This device must accept any interference, including interference that may cause undesired operation of the device.
3. Changes or modifications not expressly approved by the party responsible for compliance could void the user's authority to operate the device.

Lane Following Assist (LFA)

Lane Following Assist detects lane markings and/or a vehicle ahead on the road, and center your vehicle in the lane.

Detecting sensor

Front view camera



Front view camera (GT-Line)



The front view camera is used as a detecting sensor to detect lane markings and front vehicles.

Refer to the picture above for the detailed location of the detecting sensor.

⚠ CAUTION

For more details on the precautions of the front view camera, refer to "Forward Collision-Avoidance Assist (FCA) (Sensor Fusion) (if equipped)" on page 6-4.

Lane Following Assist settings

Warning Methods

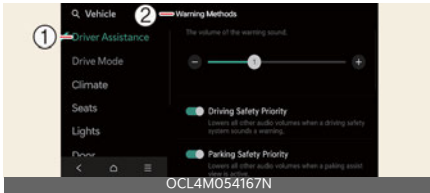

- 1 Driver Assistance
- 2 Warning Methods

The **Warning Methods** can be set with the vehicle on. Select **Setup** → **Vehicle** → **Driver Assistance** → **Warning Methods** from the settings menu in the infotainment system to change the following settings:

- **Warning Volume:** Adjusts the volume of the warning sound. If you turn off the **Warning Volume**, for your safety, the function may warn you with a low volume.
- **Driving Safety Priority:** Lowers all other audio volumes when the Driving Safety system sounds a warning.

* INFORMATION

- If you change the **Warning Methods**, it can be applied to each function of the driver assistance system. Please check and change it in each function.
- If the vehicle is restarted, **Warning Methods** will maintain the last setting.
- The setting menu may not exist based on vehicle specification.

Lane Following Assist operation

Turning Lane Following Assist On/Off



With the vehicle on, shortly press the Lane Driving Assist button located on the steering wheel to turn on Lane Following Assist. The gray or green (Ⓢ) indicator light will appear on the cluster. Press the Lane Driving Assist button again to turn off Lane Following Assist.

Warning and control

Lane Following Assist

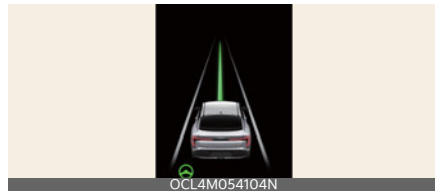

If the vehicle ahead and/or both lane markings are detected and Your driving speed is below 180 km/h (110 mph), the green (Ⓢ) indicator light appears on the cluster, and Lane Following Assist helps center the vehicle in the lane by assisting the steering wheel.

⚠ CAUTION

When the steering wheel is not assisted, the white (Ⓢ) indicator light blinks and change to gray.

Hands-off warning

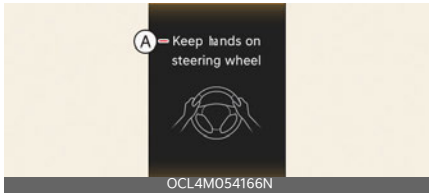

A: Keep hands on steering wheel

When the driver takes off their hands from the steering wheel for a few seconds, a warning message will appear and an audible warning will sound in stages.

- First stage: Warning message
- Second stage: Warning message (red steering wheel) and audible warning

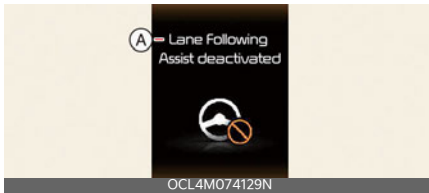

A: Lane Following Assist deactivated

If the driver still does not have their hands on the steering wheel after the hands-off warning the warning message will appear and Lane Following Assist will be automatically canceled.

WARNING

- The steering wheel may not be assisted if the steering wheel is held very tight or the steering wheel is steered over a certain degree.
- Lane Following Assist does not operate at all times. It is the responsibility of the driver to safely steer the vehicle and to maintain the vehicle in its lane.
- The hands-off warning message may appear late depending on road condi-

tions. Always have your hands on the steering wheel while driving.

- If the steering wheel is held very lightly the hands-off warning message may appear because Lane Following Assist may not recognize that the driver has their hands on the steering wheel.
- If you attach objects to the steering wheel, the hands-off warning may not work properly.

* NOTICE

- For more details on Display settings refer to "LCD display" on page 4-67.
- When both lane markings are detected, the lane lines on the cluster will change from gray to white.

Lane undetected



Lane detected

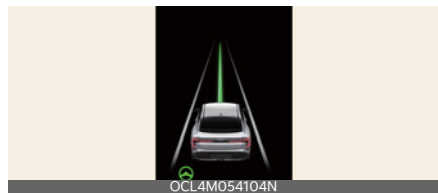

- The images and colors in the instrument cluster may differ depending on the cluster type or theme selected from the settings menu.
- If lane markings are not detected, steering wheel control by Lane Following Assist can be limited depend-

ing on whether a vehicle is in front or the driving conditions of the vehicle.

- Even though the steering is assisted by Lane Following Assist, the driver may control the steering wheel.
- The steering wheel may feel heavier or lighter when the steering wheel is assisted by Lane Following Assist than when it is not.

Lane Following Assist malfunction and limitations

Lane Following Assist malfunction

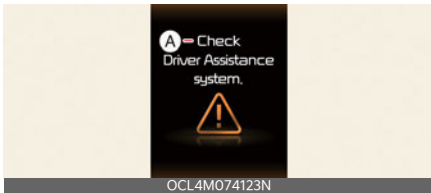

A: Check Driver Assistance system.

When Lane Following Assist is not working properly, the warning message will appear and the Master warning light (⚠) will appear on the cluster.

If this occurs, have Lane Following Assist inspected by an authorized Kia dealer.

* NOTICE

You can check it in the service message of the utility information view of the cluster display window.

Limitations of Lane Following Assist

For more details on Lane Following Assist limitations, refer to "Lane Keeping Assist (LKA)" on page 6-25.

⚠ WARNING

- For more information on Lane Following Assist limitations, refer to "Lane Keeping Assist (LKA)" on page 6-25.
- Loading in excess of the maximum load allowance or concentrated loading at one point in the cargo compartment can reduce the vehicle's driving stability, which can in turn reduce the effectiveness of Lane Following Assist.

Highway Driving Assist (HDA) (if equipped)

Highway Driving Assist



Highway Driving Assist detect lanes and vehicles ahead and help maintain the distance from the vehicle ahead and the set speed and center your vehicle in the lane while driving on the highway.

Highway Lane Change Assist (if equipped)



Highway Lane Change Assist function can help change lanes to the direction you operate the turn signal switch if the function determines that lane change is possible.

* NOTICE

- Highway Driving Assist is available only on controlled access roads of certain highways.
 - * A controlled access road indicates roads with limited entrances and exits that allow uninterrupted high speed traffic flow. Only passenger cars and motorcycles are allowed on controlled access roads.
- Additional highways may be added by future navigation updates.

Highway Driving Assist operates on main roads of highways and does not operate on interchanges or junctions.

Detecting sensor

Front view camera



Front view camera (GT-Line)



Front radar



Front radar (GT-Line)



Front corner radar (if equipped)



OCL4M054004N

Front corner radar (GT-Line)



OCL4MGTL054003

Rear corner radar (if equipped)



OCL4M054005N

Rear corner radar (GT-Line)



OCL4MGTL054004

Refer to the pictures above for the detailed location of the detecting sensors.

⚠ CAUTION

For more details on the precautions of the detecting sensors, refer to "Forward Collision-Avoidance Assist (FCA) (Sensor Fusion) (if equipped)" on page 6-4.

Highway Driving Assist settings

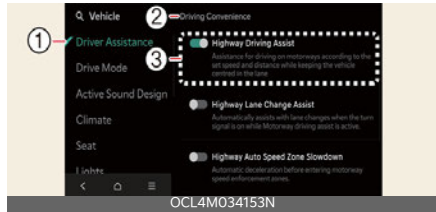

- 1 Driver Assistance
- 2 Driving Convenience
- 3 Highway Driving Assist

With the vehicle on, touch or select **Setup** → **Vehicle** → **Driver Assistance** → **Driving Convenience** on the infotainment system to set whether to use each function.

- If **Highway Driving Assist** is selected, it can help maintain distance from the vehicle ahead, maintain the set speed, and can help center the vehicle in the lane.

Highway Lane Change Assist (if equipped)

- If **Highway Lane Change Assist** is selected, it can help change lanes safely.

⚠ WARNING

For your safety, change the Settings after parking the vehicle at a safe location.

*** NOTICE**

- Highway Driving Assist should be selected to use Highway Lane Change Assist.
- If there is a problem with the function, the settings cannot be changed. Have the Highway Driving Assist inspected by an authorized Kia dealer.

- If the vehicle is restarted, the functions will maintain their last settings.

Warning Methods

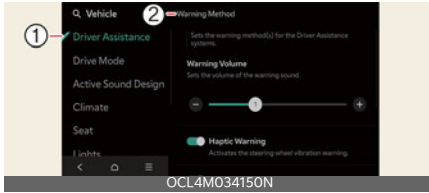

1 Driver Assistance

2 Warning Methods

The **Warning Methods** can be set with the vehicle on. Select **Setup** → **Vehicle** → **Driver Assistance** → **Warning Methods** from the settings menu in the infotainment system to change the following settings:

- **Warning Volume:** Adjusts the volume of the warning sound. If you turn off the **Warning Volume**, for your safety, the function may warn you with a low volume.
- **Driving Safety Priority:** Lowers all other audio volumes when the Driving Safety system sounds a warning.

* INFORMATION

- Ensure that **Warning Methods** you have set may apply to the **Warning Methods** of other driver assistance systems.
- **Warning Methods** will maintain its last setting even if the vehicle is restarted.
- The setting menu may not be available for your vehicle depending on the vehicle features and specifications.

Highway Driving Assist operation Highway Driving Assist

Display operating status

You can see the status of the Highway Driving Assist operation in the Driving Assist view on the instrument cluster. Refer to "LCD display modes" on page 4-67.

Operating State



Standby State

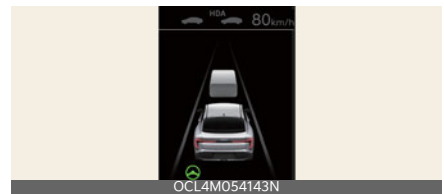

Highway Driving Assist will be displayed as below depending on the status of the function.

- 1 Highway Driving Assist indicator, whether there is a vehicle ahead and the selected distance level is displayed.
 - Highway Driving Assist indicator
 - Green HDA: Operating state
 - Gray HDA: Standby state
 - White HDA blink: Accelerator depressed state
 - None: Off state
- 2 Set speed
- 3 Lane Following Assist indicator
- 4 Whether there is a vehicle ahead and the selected headway

5 Whether the lane is detected or not

*** NOTICE**

- For more details on the display, refer to "Lane Following Assist (LFA)" on page 6-75.
- For more details on the display refer to "Smart Cruise Control (SCC) (if equipped)" on page 6-57.
- The images and colors in the instrument cluster may differ depending on the cluster type or theme selected from the settings menu.

Turning on Highway Driving Assist

Highway Driving Assist operates when:

- When driving on available roads, press Drive Assist button to turn on Highway Driving Assist.
- When entering the main roads of highways while Smart Cruise Control is operating, Driving Assist will not turn on if Lane Following Assist is turned off.

- First stage: Warning message
- Second stage: Warning message (red steering wheel) and audible warning

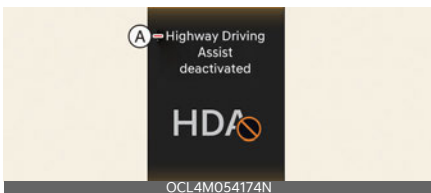

Restarting after stopping



A: Use switch or pedal to accelerate

When Highway Driving Assist is operating, your vehicle will stop if a vehicle ahead of you stops. If a vehicle ahead of you starts moving within 30 seconds after the stop, your vehicle will start as well. In addition, after the vehicle has stopped and 30 seconds have passed, a message will appear on the instrument cluster. Depress the accelerator pedal or operate the (+) switch, (-) switch or (||◻) switch to start driving.

Hands-off warning

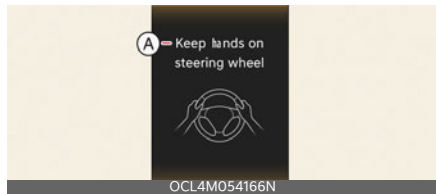

A: Keep hands on steering wheel

If you take your hands off the steering wheel for several seconds, a warning message will appear and an audible warning will sound in stages.

A: Highway Driving Assist deactivated

If the driver still does not have their hands on the steering wheel after the hands-off warning, a warning message will appear and Highway Driving Assist will be automatically canceled.

Driving speed limit



A: Driver's grasp not detected. Driving speed will be limited

When Highway Driving Assist is canceled by the hands-off warning, The driving speed will be limited.

While Driving Speed Limit function is operating, a warning message will appear on the cluster, and an audible warning will sound continuously.

Driving to one side within lane (if equipped)

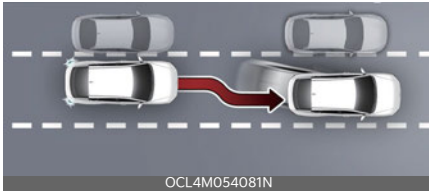

When your vehicle speed is above 60 km/h (40 mph), if a vehicle around you is driving at a close distance, your vehicle will control steering in the opposite direction of the vehicle to assist in safe driving. If there are vehicles in both sides of the lane that are driving close to you, the function will not veer to the opposite side of the lane.

Highway Driving Assist standby

When the Smart Cruise Control is temporarily canceled while Highway Driving Assist is operating, Highway Driving Assist will be in the standby state. At this time, Lane Following Assist will operate properly.

* NOTICE

- Driving Speed Limit can help you drive below 60 km/h (40 mph). Your vehicle decelerates due to the vehicle ahead. After your vehicle has decelerated, it cannot automatically accelerate.
- Driving Speed Limit will cancel in the following circumstances:
 - When you grasp the steering wheel again
 - When you turn on Lane Following Assist by pressing the Lane Driving Assist button
 - When (+), (-), (⏪) switch or (🚗) button is operated, or the accelerator pedal or the brake pedal is depressed

Highway Lane Change Assist (if equipped)

Display and control

You can see the status of the Highway Lane Change Assist function operation in the Driving Assist view on the instrument cluster. Refer to "Instrument cluster" on page 4-62.

Highway Lane Change Assist function will be displayed as below depending on the status of the function.

Ready/Operating

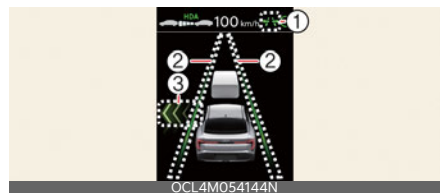

Standby/Canceled



1 Highway Lane Change Assist indicator

- Green (↔↔) on: Ready state
- Green (↔↔) blink: Operating state
- Gray (↔↔) on: Standby state
- White (↔↔) blink: Canceled state (display only a certain time)

2 Lane line

The lane line is displayed identical to Highway Lane Change Assist indicator (1). However, the lane detection availability will be showed on Standby state.

3 Green arrow and shade

The green arrow is displayed when a certain amount of time has passed after the function has started operating, and until the lane change has completed.

4 Message

- Message is displayed when the function does not operate even though the turn signal lever is used.
- Message is displayed when the function is canceled while operating.

Highway Lane Change Assist function will turn on when the following conditions are satisfied.

- The Driving Assist button or Lane Driving Assist button is used to turn on Highway Driving Assist.

Turning on Highway Lane Change Assist



A: Press OK button to enable Lane Change Assist

While Highway Lane Change Assist function is on, the function will be ready to operate when all the following conditions are satisfied:

- Highway Driving Assist is operating
- Lane Following Assist is operating
- A vehicle behind your vehicle is detected more than once after your vehicle is turned on
- Your driving speed is above 30 km/h (20 mph)
- When driving at low speeds (30~60 km/h (20~40 mph)), your vehicle can only be operated if vehicles in the left and right adjacent lanes are recognized, and there is no risk of collision when changing lanes.
- Hands-off warning is not displayed on the instrument cluster
- Hazard warning flasher is off

* NOTICE

- While Lane Change Assist function is turned on (indicator on), Lane Following Assist will not cancel even if the turn signal indicator or hazard warning flasher is operating.
- Lane Change Assist function turns off automatically when driven in the following road conditions:
 - One driving lane

- Roads lacking physical center separation structures (such as guard-rails)
- There is a pedestrian or cyclist on the road ahead
- If the driving speed slows down to less than 25 km/h (15 mph) when it is in ready state, it will change to standby state.
- When driving at low speeds (30~60 km/h (20~40 mph)), the vehicle will change to standby state if it is not recognized by vehicles in the left and right adjacent lanes.
- If a risk of collision is detected, the system will change to standby state.
- The images or colors may be displayed differently depending on the specifications of the instrument cluster or theme.

⚠ WARNING

When Highway Lane Change Assist function turns off while operating, steering assist will be temporarily canceled. Always be cautious while driving.

Highway Lane Change Assist operating



1. Middle

Highway Lane Change Assist function will operate, when you push the turn signal lever to (A) or (B) position while the function is in the ready state (🚦) indi-

cator is green), and all the following conditions are satisfied:

- Your hands are on the steering wheel
- There is no collision risk in the direction of lane change
- There is a two-lane road with broken lines of any colors in the direction of the lane change
- There are no Forward Collision-Avoidance Assist and Blind Spot Collision-Avoidance Assist warnings
- You are driving in the middle of the lane (should not be driving close to one side of the lane)
- The road you are driving on, or the road you are about to change lane is a road that the function can operate

*** NOTICE**

- When the turn signal lever is placed at (A) position, the Highway Lane Change Assist function is performed. After that, if the turn signal lever is placed in neutral, Highway Lane Change Assist function is canceled before stepping on the lane. The Highway Lane Change Assist function is not canceled after stepping on the lane, but when the lane change is complete, it is canceled and the turn signal turns off.
- When the turn signal lever is placed at B position for a certain period, the green arrow will appear. Even when the lever is released and returns to its original position, lane change will still be assisted.
- While lane change is occurring, the turn signal indicator will blink even when not holding the turn signal lever. The turn signal indicator will turn off when the lane change is complete.

Highway Lane Change Assist standby

Highway Lane Change Assist function will be in the standby state when one of the ready state conditions is not satisfied, or when entering or driving on one of the following roads:

- Road within a certain distance from the tollgate on the main road of the highway (or motorway)
- Road ahead ends without an interchange or junction
- Road with sharp curves
- Road with narrow lanes

Canceling Highway Lane Change Assist

The function will be canceled when:

- The turn signal lever is turned in the opposite direction of lane change
- The steering wheel is steered sharply
- If the turn signal switch is moved to position (A) while the Lane Change Assist is operating and then returned to the N (Neutral) position before changing lanes

WARNING

- While the function is operating, it will cancel if one of the following occurs:
 - Highway Driving Assist is turned off
 - Lane Following Assist or Smart Cruise Control is turned off or temporarily canceled
 - Hands-off warning message is displayed on the instrument cluster
 - The turn signal lever is placed at (A) position
 - The hazard warning flasher is turned on
 - Forward Collision-Avoidance Assist or Blind-Spot Collision-Avoidance

Assist warning message is displayed

- Possible collision is detected in the next lane, even though there are no Forward Collision-Avoidance Assist and Blind Spot Collision-Avoidance Assist warning
- The target lane disappears
- The target lane is not detected
- There is a problem with turn signal lights
- Highway Lane Change Assist function is off. (The function turns off when: it is turned off from the settings menu; when the road changes to a one-way road; when there is an intersection or crosswalk ahead; when you enter a road with no structure, such as a median strip, guardrail, etc., or; when there is a pedestrian or cyclist in the driving lane.)
- If the driving speed slows down to less than 25 km/h (15 mph) when it is in ready state, it will change to standby state.
- When driving at low speeds (30~60 km/h (20~40 mph)), the vehicle will change to standby state if it is not recognized by vehicles in the left and right adjacent lanes.
- If a risk of collision is detected
- While the function is operating, if it is canceled, depending on the driving conditions, the vehicle may drive to the middle of the driving lane or steering assist may stop. Always pay attention to the road and driving conditions.
- The function may not operate normally on roads with pedestrians or cyclists, such as an intersection or

crosswalk. Always pay attention to the road and driving conditions.

Highway Driving Assist malfunction and limitations

Highway Driving Assist malfunction

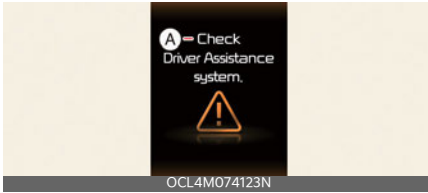

A: Check Driver Assistance system

When Highway Driving Assist is not working properly, a warning message will appear, and the Master warning light (⚠) will appear on the instrument cluster.

Have Highway Driving Assist inspected by an authorized Kia dealer.

⚠ WARNING

- You are responsible for controlling the vehicle for safe driving.
- Always have your hands on the steering wheel while driving.
- Highway Driving Assist is a supplemental function that assists you in driving the vehicle. It is not a complete autonomous driving system. Always check road conditions take appropriate actions to drive safely.
- Always have your eyes on the road. It is your responsibility to avoid violating traffic laws. Kia is not responsible for any traffic violations or accidents caused by you.
- Highway Driving Assist may not be able to recognize all traffic situations. Highway Driving Assist may not detect possible collisions due to its limitations. Always be aware of its limitations. Obstacles such as vehicles, motorcycles, bicycles, pedestrians, or unspecified objects or structures such as guardrails, tollgate, etc., that may collide with your vehicle may not be detected.
- Highway Driving Assist will turn off automatically under the following situations:
 - Driving on roads that Highway Driving Assist does not operate, such as a rest area, intersection, junction, etc.
 - The navigation does not operate properly such as when the navigation is updating or restarting.
- Highway Driving Assist may inadvertently operate or turn off depending on road conditions (navigation information) and surroundings.
- Lane Following Assist function may be temporarily disabled when the front view camera cannot detect lanes properly or the hands-off warning is on.
- You may not hear the warning sound of Highway Driving Assist in noisy surroundings.
- If the vehicle is driven at a speed above a certain speed on a curve, your vehicle may drive to one side or may depart from the driving lane.
- When you are towing a trailer or another vehicle, turn off Highway Driving Assist for safety reasons.
- The hands-off warning message may appear early or late depending on how you handle the steering or on road conditions. Always have your hands on the steering wheel while driving.

- For your safety, please read the owner's manual before using the Highway Driving Assist.
- Highway Driving Assist will not operate when the vehicle is started, or when the detecting sensors or navigation is being initialized.

* NOTICE

You can check it in the service message of the utility information view of the instrument cluster display window.

Limitations of Highway Driving Assist

Highway Driving Assist and Highway Lane Change Assist may not operate properly, under the following circumstances:

- The map information and the actual road is different because the navigation is not updated
- The map information and the actual road is different because of real-time GPS data or map information error
- The infotainment system is overloaded by simultaneously performing functions such as route search, video playback, voice recognition, etc.
- GPS signals are blocked in areas such as a tunnel
- You veer off course, reset the navigation route by changing the destination (including route change according to real-time road traffic information) or cancel the route to the destination
- The vehicle enters a service station or rest area
- Android Auto or CarPlay is operating
- The navigation cannot detect the current vehicle position (for example, elevated roads, including overpasses

adjacent to general roads or nearby parallel roads)

- If your vehicle fails to recognize white single dashed lane lines and road boundaries
- If some lanes are temporarily restricted
- If there are no physical separation structures, such as a center median, in the middle of the road
- If the lane you intend to change to is a bus lane or a variable lane
- If you have a trailer, carrier, or other equipment attached

* NOTICE

For more details of the front view camera, front radar, front corner radar and rear corner radar sensor, refer to "Forward Collision-Avoidance Assist (FCA) (Sensor Fusion) (if equipped)" on page 6-4.

This device complies with Industry Canada licence-exempt RSS standard(s).

Operation is subject to the following three conditions:

1. This device may not cause interference, and
2. This device must accept any interference, including interference that may cause undesired operation of the device.
3. Changes or modifications not expressly approved by the party responsible for compliance could void the user's authority to operate the device.

Rear View Monitor (RVM) (if equipped)

Rear View Monitor displays the area behind your vehicle to help with safe parking.

Detecting sensor

Wide-rear view camera

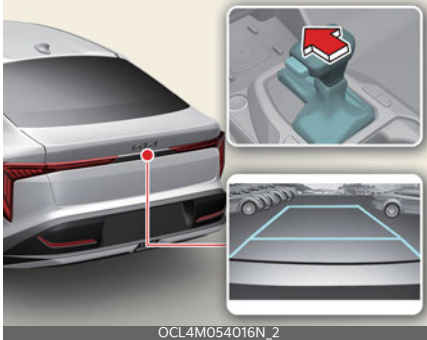

Wide-rear view camera (GT-Line)

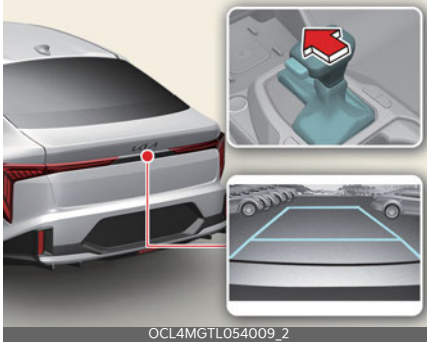

Refer to the picture above for the detailed location of the detecting sensor.

Rear View Monitor settings

Warning Methods

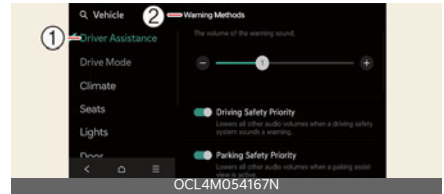

1 Driver Assistance

2 Parking Safety Priority

The **Warning Methods** can be set with the vehicle on. Select **Setup** → **Vehicle** → **Driver Assistance** → **Warning Methods** from the settings menu in the infotainment system to change the following settings:

- **Parking Safety Priority:** Lowers all other audio volumes when Rear View Monitor is active.

* INFORMATION

- If you change the **Warning Methods**, it can be applied to each function of the driver assistance system. Please check and change it in each function.
- If the vehicle is restarted, **Warning Methods** will maintain the last setting.
- The setting menu may not exist based on vehicle specification.

Camera Settings

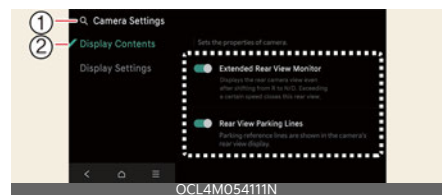

1 Camera Settings

2 Display Contents

With the vehicle on, select the setup icon (⚙️) on the screen or **Setup** → **Vehicle** → **Driver Assistance** → **Parking Safety** → **Camera Settings** from the infotainment system screen to change the Rear View Monitor settings.

Extended Rear View Monitor

If Extended Rear View Monitor use is selected, the rear camera is displayed even when shifting from R (Reverse) to N (Neutral) or D (Drive).

Rear View Parking Guidance

If Rear View Parking Guidance in the display information is selected, Rear View Parking Guidance and Top Rear View Parking Guidance are displayed in the rear monitor.

*** NOTICE**

The setting menu may not be available for your vehicle depending on the vehicle specifications.

*** NOTICE**

- The horizontal lines of the Rear View Parking Guidance indicate distances of 0.5 m (20 in), 1 m (40 in) and 2.3 m (91 in) from the vehicle. based on the empty vehicle condition.
- The horizontal scale of the Top View Parking Guidance indicates distances of 0.5 m (20 in), and 1.5 m (60 in) from the vehicle. based on the empty vehicle condition.

Rear View Monitor operation

Parking/View button



Press the Parking/View button (1) while the gear is in P (Park) or N (Neutral) to turn on the Rear View Monitor.

Rear view

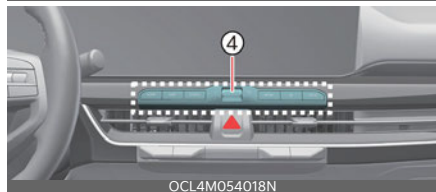
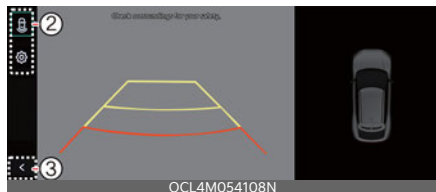

Operating conditions

The Rear View function will turn on under the following conditions:

- Shifting the gear to R (Reverse).
- Pressing the Parking/View button (1) while P (Park), N (Neutral) or D (Drive) and the vehicle speed is slower than 10 km/h (6 mph)

Pressing the View switching button (2) with the Rear top view on the screen allows you to select rear top view, rear view, or rear wide view.

Off conditions

The Rear View while parking function will turn off under the following conditions while parking:

- Shifting the gear to P (Park)
- Pressing the Parking/View button (1)
- Pressing the back button (3) on the rear monitor screen
- Pressing the infotainment system operation button (4)
- N (Neutral) or D (Drive) and the vehicle speed is faster than 10 km/h (6 mph)

* NOTICE

Rear View will not turn off when the vehicle is in R (Reverse).

Extended Rear View Monitor

Extended Rear View Monitor function maintains the rear view of the vehicle when shifting the gear from R (Reverse) to N (Neutral) or D (Drive) to help you park safely.

Operating conditions

Rear View Monitor will maintain when the following conditions are satisfied:

- Shifting the gear from R (Reverse) to N (Neutral) or D (Drive).
- Your driving speed is below approximately 10 km/h (6 mph).

Off conditions

Extended Rear View Monitor function will turn off when one the following conditions are satisfied:

- Shifting the gear to P (Park)
- Pressing the Parking/View button (1)
- Pressing the back button (3) on the rear monitor screen
- Pressing the infotainment system operation button (4)
- The vehicle speed is faster than 10 km/h (6 mph)

Rear top view

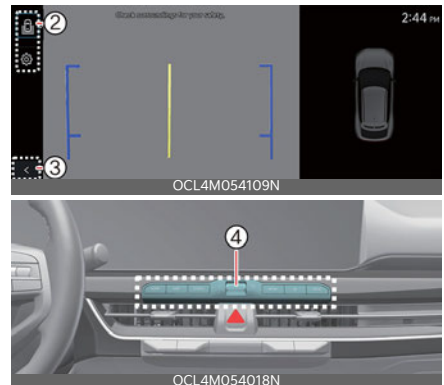

The rear top view shows an image of the vehicle looking down from above, allowing you to determine the distance from the rear vehicle or object when parking. Press the Rear Top View button to turn on the Rear Top View.

* NOTICE

- In all views, the video will not turn off when the vehicle is in R (Reverse) mode.
- The rear view will always be displayed in R (Reverse).
- Rear parking guidelines are displayed in the rear view and rear top view. Select **Setup** → **Vehicle** → **Driver Assistance** → **Parking Safety** → **Camera Settings** → **Display Information** → **Rear Parking Guidelines** from the settings menu in the infotainment system to display the guidelines. However, rear parking guidelines are not displayed in the rear view while parking.

Rear View Monitor malfunction and limitations

Rear View Monitor malfunction

When Rear View Monitor is not working properly, or the screen flickers, or the camera image does not display properly, have the vehicle inspected by an authorized Kia dealer.

Limitations of Rear View Monitor

When the vehicle is stopped for a long time in winter or when the vehicle is parked in an indoor car park, the exhaust fumes may temporarily blur the image.

⚠ WARNING

- The wide-rear view camera does not cover the complete area behind the vehicle. The driver should always check the rear area directly through the inside and outside rear view mirror before parking or backing up.
- The distance to the object shown on the screen may differ from the actual distance. This is because the image shown on Rear View Monitor is displayed by calibrating the image from the wide-rear view camera. When the vehicle is tilted by cargo loading, rear parking guidelines may not be correct. Make sure to directly check the vehicle's surroundings for safety.
- Always keep the wide-rear view camera lens clean. If the lens is covered with foreign material, it may adversely affect camera performance and Rear View Monitor may not operate properly. However, do not use chemical solvents such as strong detergents containing high alkaline or volatile organic solvents (gasoline, acetone etc.). This may damage the camera lens.

360° camera monitoring system (if equipped)

360° camera monitoring system can assist in parking by allowing the driver to see around the vehicle.

Detecting sensor

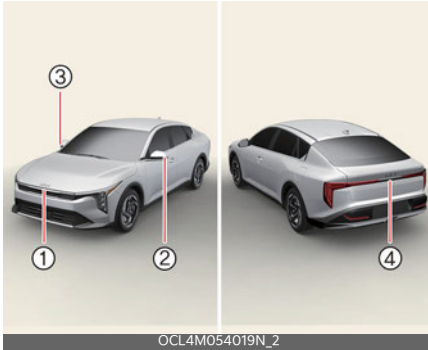

GT-Line

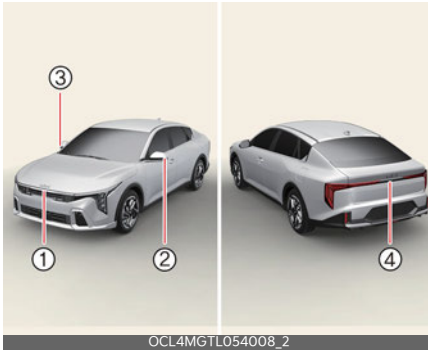

- 1 Wide-front view camera
- 2, 3 Wide-side view camera
- 4 Wide-rear view camera

Refer to the picture above for the detailed location of the detecting sensor.

360° camera monitoring system settings

Warning Methods

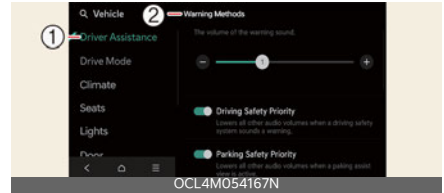

- 1 Driver Assistance
- 2 Warning Methods

The Warning methods can be set with the vehicle on. Select **Setup** → **Vehicle** → **Driver Assistance** → **Warning Methods** from the settings menu in the infotainment system to change the following settings:

- **Parking Safety Priority:** Lowers all other audio volumes when 360° camera monitoring system is active.

* INFORMATION

- If you change the **Warning Methods**, it can be applied to each function of the driver assistance system. Please check and change it in each function.
- If the vehicle is restarted, **Warning Methods** will maintain the last setting.
- The setting menu may not exist based on vehicle specification.

Camera Settings

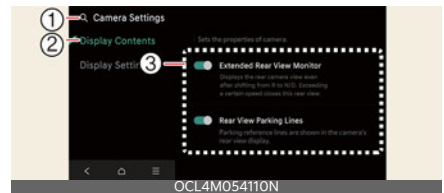

- 1 Camera Settings
- 2 Display Contents

3 Display Settings

With the vehicle on, select the setup icon (⚙️) on the screen or **Setup** → **Vehicle** → **Driver Assistance** → **Parking Safety** → **Camera Settings** from the infotainment system screen to change the 360° camera monitoring system settings.

- **Display Contents:** Specify information that will be displayed on the parking assistance screen.

Parking Distance Warning

Parking distance warning is displayed on the right side of the 360° camera monitoring system top view screen when the **Parking Distance Warning** is selected.

Top View Parking Guidance

Parking guidance is displayed on the right side of the 360° camera monitoring system screen when the **Front or Rear Top View Parking Guidance** is selected.

Rear View Parking Guidance

Rear view parking guidance is displayed in the rear view when the **Parking guide in rear view** is selected.

* NOTICE

- The setting menu may not be available for your vehicle depending on the vehicle features and specifications.
- The horizontal guidelines of the Rear View Parking Guidance indicate distances of 0.5 m (20 in), 1 m (40 in) and 2.3 m (91 in) from the vehicle.
- The horizontal scale of the Rear Top View Parking Guidance indicates distances of 0.5 m (20 in) and 2 m (79 in) from the vehicle.

Surround View Monitor Auto On

With the vehicle on, select **Setup** → **Vehicle** → **Driver Assistance** → **Parking Safety** → **Surround View Monitor Auto On** from the infotainment system screen to use the function.

* NOTICE

For more details on Surround View Monitor Auto On, refer to "360° camera monitoring system (if equipped)" on page 6-93.

360° camera monitoring system operation

Parking/View button

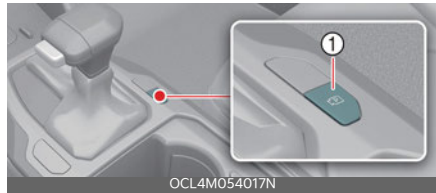

Press the Parking/View button (1) to turn on 360° camera monitoring system. Press the button again to turn off the function.

Front view

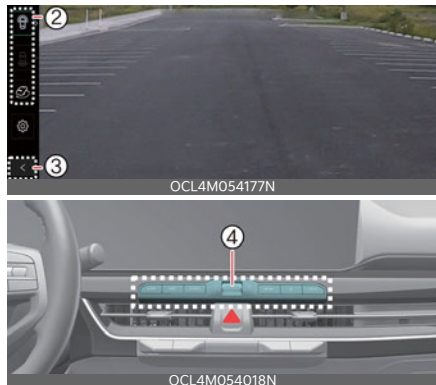

The front view function displays the vehicle's front situation on the navigation system according to the driver's settings, assisting in safe driving.

Parking

While parking, the front view of the 360° camera monitoring system is activated in the following conditions:

- P (Park) or N (Neutral) or D (Drive) position with a vehicle speed slower than 10 km/h (6 mph), Pressing the Parking/View button (1).
- Shifting from R (Reverse) to N (Neutral) or D (Drive).
- When the automatic activation function of the 360° camera monitoring system is enabled

Pressing the view switching button (2) on the 360° camera monitoring system to select the Top View, Front View, Front Side View, or Front Wide View.

While parking, the front view of the 360° camera monitoring system will be turned off in the following conditions:

- Shifting to P (Park) or R (Reverse)
- Pressing the Parking/View button (1)
- Pressing the back button (3) on the 360° camera monitoring system screen
- Pressing the infotainment system power button (4)
- Driving faster than 10 km/h (6 mph)

* NOTICE

When the front view is activated, the last used view is displayed.

Rear view

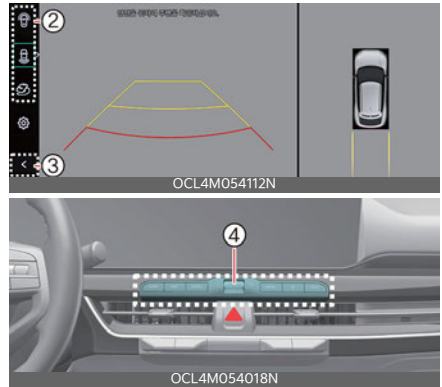

The rear view function of the 360° camera monitoring system displays the vehicle's rear situation on the navigation system according to the driver's settings, assisting in safe parking.

Parking

While parking, the rear view of the 360° camera monitoring system is activated in the following cases:

- P (Parking) or N (Neutral) or D (Drive) position with a vehicle speed slower than 10 km/h (6 mph) Pressing the Parking/View button (1) and then pressing the view switching button (2) to select the rear view
- Shifting to R (Reverse)

Pressing the view switching button (2) on the 360° camera monitoring system to select the rear view, rear top view, rear side view, or rear wide view.

While parking, the rear view function of the 360° camera monitoring system is turned off in the following conditions when the vehicle is in P (Park) or N (Neutral) or D (Drive) mode:

- Shifting from N (Neutral) or D (Drive) to P (Parking)
- Pressing the Parking/View button (1)

- Pressing the back button (3) on the 360° camera monitoring system screen
- Pressing the infotainment system power button (4)
- Driving faster than 10 km/h (6 mph)

When the vehicle is in R (Reverse), the rear view function of the 360° camera monitoring system will be turned off in the following conditions:

- Shifting to P (Parking)

*** NOTICE**

- The rear view will always be displayed in R (Reverse).
- In R (Reverse) position, the video will not be turned off by pressing the infotainment system power button (4).

3D view function

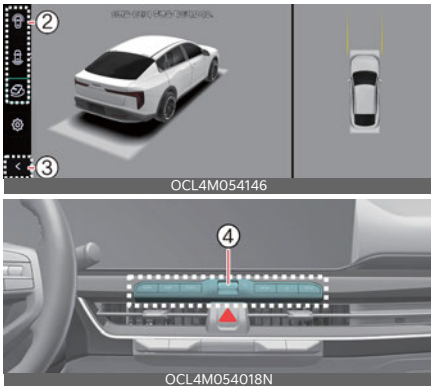

3D view function shows the vehicle in various angles. Press the 3D view icon on the 360° camera monitoring system screen to choose the angle. Press the 3D view icon again to reset the angle. The 3D view of the 360° camera monitoring system is activated under the following conditions:

- P (Parking) or N (Neutral) or D (Drive) position with a vehicle speed slower than 10 km/h (6 mph) or when selecting the 3D view button (2) while the 360° camera monitoring system is activated in R (Reverse) mode.

The 3D view function of the 360° camera monitoring system while parking will be turned off under the following conditions:

- Shifting from N (Neutral) or D (Drive) to P (Parking)
- Pressing the Parking/View button (1)
- Pressing the back button (3) on the 360° camera monitoring system screen
- Pressing the infotainment system power button (4)
- Driving faster than 10 km/h (6 mph)

When the vehicle is in R (Reverse), the 3D view function of the 360° camera monitoring system will be turned off under the following conditions:

- Shifting to P (Parking)

*** NOTICE**

- The 3D view does not display parking guidelines.
- The top view screen, which is displayed with a Front/Rear view or 3D view, converts the original images entered from the four wide-angle cameras to provide a 360-degree image around the vehicle that is viewed down.
- Top view is not displayed with front/rear wide view.
- Zoom in or out on the top view by pinching within the top view area.

360° camera monitoring system malfunction and limitations

360° camera monitoring system malfunction

When 360° camera monitoring system is not working properly, or the screen flickers, or the camera image does not display normally, have the vehicle inspected by an authorized Kia dealer.

Limitations of 360° camera monitoring system

- The screen may be displayed abnormally, and an icon will appear at the top left side of the screen under the following circumstances:
 - The trunk is opened.
 - The driver or front passenger door is opened.
 - The outside rear view mirror is folded.

WARNING

- ALWAYS look around your vehicle to make sure there are no objects or obstacles before moving the vehicle. What you see on the screen may differ from the actual vehicle's location.
- The distance to the object shown on the screen may differ from the actual distance. This is because the image shown on 360° camera monitoring system is displayed by calibrating the image from the wide-rear view camera. When the vehicle is tilted by cargo loading, rear parking guidelines may not be correct. Make sure to directly check the vehicle's surroundings for safety
- 360° camera monitoring system is designed to be used on a flat surface. Therefore, if used on roads with different heights such as curbs and

speed bumps, the image in the screen may not look correct.

- Always keep the camera lens clean. If the lens is covered with foreign material, it may adversely affect camera performance and 360° camera monitoring system may not operate normally. However, do not use chemical solvents such as strong detergents containing high alkaline or volatile organic solvents (gasoline, acetone etc.). This may damage the camera lens.

Rear Cross-Traffic Collision-Avoidance Assist (RCCA) (if equipped)

Rear Cross-Traffic Collision-Avoidance Assist detects vehicles approaching from the rear left or right while your vehicle is reversing and warns you of a possible collision with a warning message and a warning sound. Also, Rear Cross-Traffic Collision-Avoidance Assist may assist with braking your vehicle to help avoid a collision.

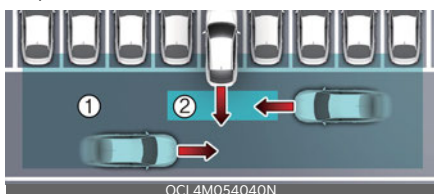

1. Rear Cross-Traffic Collision Warning operating range
2. Rear Cross-Traffic Collision-Avoidance Assist operating range

⚠ CAUTION

Warning timing may vary depending on vehicle speed of the approaching vehicle.

Detecting sensor

Rear corner radar



Rear corner radar (GT-Line)



Refer to the picture above for the detailed location of the detecting sensors.

* NOTICE

For more details on the precautions of the rear corner radar, refer to "Blind-Spot Collision-Avoidance Assist (BCA) (if equipped)" on page 6-31.

Rear Cross-Traffic Collision-Avoidance Assist settings

Rear Cross-Traffic Safety



- 1 Driver Assistance
- 2 Parking Safety
- 3 Rear Cross-Traffic Safety

With the vehicle on, select **Setup** → **Vehicle** → **Driver Assistance** → **Parking Safety** → **Rear Cross-Traffic Safety** on the infotainment system screen to turn on Rear Cross-Traffic Collision-Avoidance Assist.

⚠ WARNING

When the vehicle is restarted, Rear Cross-Traffic Collision-Avoidance Assist will always turn on. You can turn off the function on the settings menu. If Rear

Cross-Traffic Safety is deselected, you cannot get help from Rear Cross-Traffic Collision-Avoidance Assist. The driver should always be aware of the surroundings and drive safely.

⚠ CAUTION

Steering wheel vibration warning can be turned on or off in the settings menu.

*** NOTICE**

Rear Cross-Traffic Safety settings include 'Rear Cross-Traffic Collision Warning' and 'Rear Cross-Traffic Collision-Avoidance Assist'.

*** NOTICE**

When the vehicle turn off and on, the warning volume settings will maintain the last setting.

Warning Methods

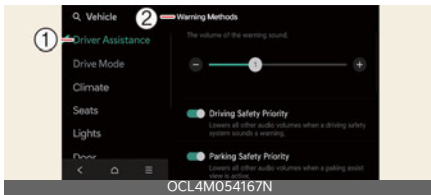

1 Driver Assistance

2 Warning Methods

The Warning Methods can be set with the vehicle on. Select **Setup** → **Vehicle** → **Driver Assistance** → **Warning Methods** from the settings menu in the infotainment system to change the following settings

- **Warning Volume:** Adjusts the volume of the warning sound.
- **Haptic Warning:** Activate the steering wheel vibration warning.

*** INFORMATION**

- If you change the **Warning Methods**, it can be applied to each function of the driver assistance system. Please check and change it in each function.
- If the vehicle is restarted, **Warning Methods** will maintain the last setting.
- The setting menu may not exist based on vehicle specification.
- The Warning Volume and **Haptic Warning** cannot be turned off at the same time. When one of the warning is turned off the other is activated.

Rear Cross-Traffic Collision-Avoidance Assist operation

Rear Cross-Traffic Collision-Avoidance Assist will warn and control the vehicle depending on collision risk level:

- Collision warning
- Emergency braking
- Stopping vehicle and ending brake control

Collision warning



type or theme selected from the cluster.



A: Collision Warning

Collision warning will alert the driver with a warning light on the outside rear view mirror, a warning message, an audible warning, and the steering wheel will vibrate (if equipped).

Collision warning will also appear on the infotainment system screen.

Collision warning will operate when all the following conditions are satisfied:

- The gear is shifted to R (Reverse) while your driving speed is below 8 km/h (5 mph)
- The approaching vehicle is within approximately 25 m (82 ft) from the left and right side of your vehicle
- The speed of the vehicle approaching from the left and right is above 5 km/h (3 mph)

*** NOTICE**

- If the operating conditions are satisfied, there will be a warning whenever the vehicle approaches from the left or right side even though your vehicle speed is stopped.
- The images and colors in the cluster may differ depending on the cluster

Emergency braking

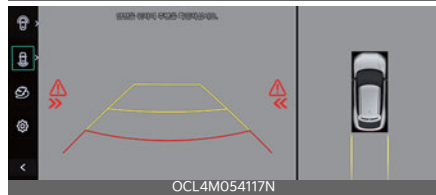
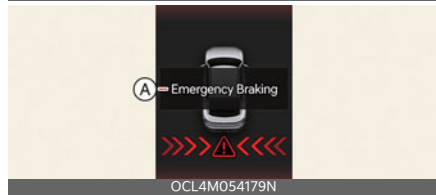
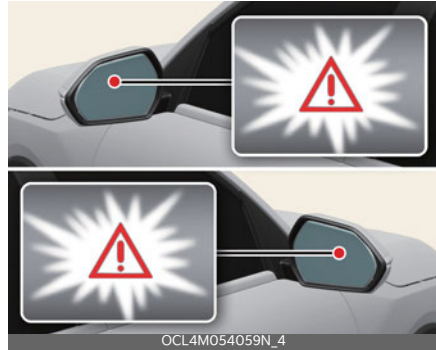

A: Emergency Braking

Collision warning will alert the driver with a warning light on the outside rear view mirror, a warning message, an audible warning, and the steering wheel will vibrate.

Collision warning will also appear on the infotainment system screen (if equipped).

Emergency braking will be assisted to help prevent collision with approaching vehicles from the left and right.

Emergency braking will operate when all the following conditions are satisfied:

- The gear is shifted to R (Reverse) while your driving speed is below 8 km/h (5 mph)
- The approaching vehicle is within approximately 1.5 m (5 ft) from the left and right side of your vehicle
- The speed of the vehicle approaching from the left and right is above 5 km/h (3 mph)

⚠ WARNING

Brake control ends when the conditions of the approaching vehicle from the rear left or right side are as below:

- The approaching vehicle is out of the detecting range
- The approaching vehicle passes behind your vehicle
- The approaching vehicle does not drive toward your vehicle
- The approaching vehicle speed slows down
- The driver depresses the brake pedal with sufficient power

Stopping vehicle and ending brake control

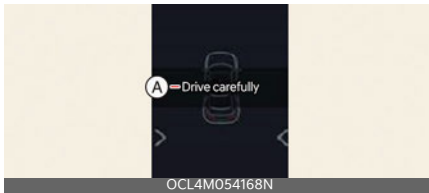

A: Drive carefully

When the vehicle is stopped due to emergency braking, the warning message will appear on the cluster.

For your safety, the driver should depress the brake pedal immediately and check the surroundings.

- Brake control will end after the vehicle is stopped by emergency braking for approximately 2 seconds.
- During emergency braking, braking control by Rear Cross-Traffic Collision-Avoidance Assist will automatically cancel when the driver excessively depresses the brake pedal.

⚠ WARNING

- For your safety, change the Settings after parking the vehicle at a safe location.
- If any other function's warning message is displayed or audible warning is generated, Rear Cross-Traffic Collision-Avoidance Assist's warning message may not be displayed and audible warning may not be generated.
- You may not hear the warning sound of Rear Cross-Traffic Collision-Avoidance Assist if the surrounding is noisy.
- Rear Cross-Traffic Collision-Avoidance Assist may not operate if the driver applies the brake pedal to avoid collision.
- During Rear Cross-Traffic Collision-Avoidance Assist operation, the vehicle may stop suddenly injuring passengers and shifting loose objects. Always have the seat belt on and keep loose objects secured.
- Even if there is a problem with Rear Cross-Traffic Collision-Avoidance Assist, the vehicle's basic braking performance will operate properly.

⚠ WARNING

- When Rear Cross-Traffic Collision-Avoidance Assist is operating, braking control by function will automatically

cancel when the driver excessively depresses the accelerator pedal.

- Rear Cross-Traffic Collision-Avoidance Assist does not operate in all situations or cannot avoid all collisions.
- Rear Cross-Traffic Collision-Avoidance Assist may warn the driver late or may not warn the driver depending on the road and driving conditions.
- The driver should hold the responsibility to control the vehicle. Do not solely depend on Rear Cross-Traffic Collision-Avoidance Assist. Rather, maintain a safe braking distance, and if necessary, depress the brake pedal to reduce driving speed or to stop the vehicle.
- Never deliberately operate Rear Cross-Traffic Collision-Avoidance Assist on people, animals, objects, etc. It may cause serious injury or death.

⚠ WARNING

The brake control may not operate properly depending on the status of ESC (Electronic Stability Control).

There will only be a warning when:

- The ESC (Electronic Stability Control) warning light is on
- ESC (Electronic Stability Control) is engaged in a different function

*** NOTICE**

- If braking is assisted by Rear Cross-Traffic Collision-Avoidance Assist, the driver must immediately depress the brake pedal and check vehicle surroundings.
- After shifting the gear to R (Reverse), braking control will operate once for left and right vehicle approach.

Rear Cross-Traffic Collision-Avoidance Assist malfunction and limitations

Rear Cross-Traffic Collision-Avoidance Assist malfunction

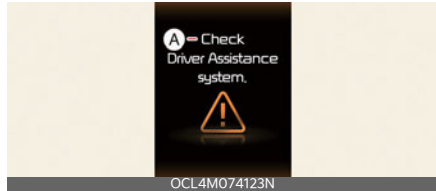

A: Check Driver Assistance system.

When Rear Cross-Traffic Collision-Avoidance Assist is not working properly, the warning message will appear on the cluster for several seconds, and the Master warning light (⚠) will appear on the cluster.

If this occurs, have Rear Cross-Traffic Collision-Avoidance Assist inspected by an authorized Kia dealer.

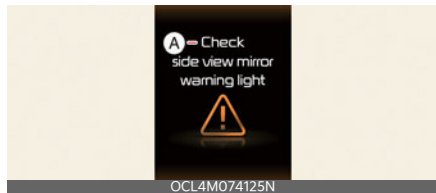

A: Check side view mirror warning light

When the outside rear view mirror warning light is not working properly, the warning message will appear on the cluster for several seconds, and the Master warning light (⚠) will appear on the cluster.

If this occurs, have Rear Cross-Traffic Collision-Avoidance Assist inspected by an authorized Kia dealer.

Rear Cross-Traffic Collision-Avoidance Assist disabled

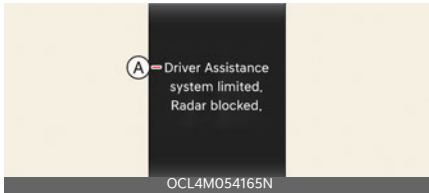

A: Driver Assistance system limited. Radar blocked.

When the rear bumper around the rear-side radar or sensor is covered with foreign material, such as snow or rain, or installing a trailer or carrier, it can reduce the detecting performance and temporarily limit or disable Rear Cross-Traffic Collision-Avoidance Assist.

If this occurs, the warning message will appear on the cluster.

Rear Cross-Traffic Collision-Avoidance Assist will operate properly when such foreign material or trailer, etc., is removed.

If Rear Cross-Traffic Collision-Avoidance Assist does not operate properly after it is removed, have Rear Cross-Traffic Collision-Avoidance Assist inspected by an authorized Kia dealer.

⚠ WARNING

- Even though the warning message does not appear on the cluster, Rear Cross-Traffic Collision-Avoidance Assist may not operate properly.
- Rear Cross-Traffic Collision-Avoidance Assist may not operate properly in an area (for example, open terrain), where any substance are not detected after turning ON the vehicle.

⚠ CAUTION

Turn off Rear Cross-Traffic Collision-Avoidance Assist to install or remove a trailer, carrier, or another attachment. Turn on Rear Cross-Traffic Collision-Avoidance Assist when finished.

Limitations of Rear Cross-Traffic Collision-Avoidance Assist

Rear Cross-Traffic Collision-Avoidance Assist may not operate properly, or it may operate unexpectedly under the following circumstances:

- Departing from where trees or grass are overgrown
- Departing from where roads are wet
- Speed of the approaching vehicle is fast or slow

Braking control may not work, driver's attention is required in the following circumstances:

- The vehicle severely vibrates while driving over a bumpy road, uneven road or concrete patch
- Driving on a slippery surface due to snow, water puddle, ice, etc.
- The tire pressure is low or a tire is damaged
- The brake is tuned
- Remote Smart Parking Assist is operating (if equipped)

*** NOTICE**

For more details on the limitations of the rear corner radar, refer to "Blind-Spot Collision-Avoidance Assist (BCA) (if equipped)" on page 6-31.

⚠ WARNING

- Driving near a vehicle or structure



1. Structure

Rear Cross-Traffic Collision-Avoidance Assist may be limited when driving near a vehicle or structure, and may not detect the vehicle approaching from the left or right. If this occurs, the function may not warn the driver or control the brakes when necessary. Always check your surroundings while backing up.

- When the vehicle is in a complex parking environment



Rear Cross-Traffic Collision-Avoidance Assist may detect vehicles which are parking or pulling out near your vehicle (example, a vehicle leaving beside your vehicle, a vehicle parking or pulling out in the rear area, a vehicle approaching your vehicle making a turn, etc.).

If this occurs, the function may unnecessarily warn the driver and control the brake.

Always check your surroundings while backing up.

- When the vehicle is parked diagonally



1. Vehicle

Rear Cross-Traffic Collision-Avoidance Assist may be limited when backing up diagonally, and may not detect the vehicle approaching from the left or right. If this occurs, the function may not warn the driver or control the brakes when necessary. Always check your surroundings while backing up.

- When the vehicle is on or near an inclined road



Rear Cross-Traffic Collision-Avoidance Assist may be limited when the vehicle is on an uphill or downhill road, or near it, and may not detect the vehicle approaching from the left or right. If this occurs, the function may not warn the driver or control the brakes when necessary.

Always check your surroundings while backing up.

- Pulling into the parking space where there is a structure



1. Structure
2. Vehicle

Rear Cross-Traffic Collision-Avoidance Assist may detect vehicles passing by in front of you when parking in reverse into a parking space with a wall or structure in the rear or side area. If this occurs, the function may unnecessarily warn the driver and control the brake.

Always check your surroundings while backing up.

- When the vehicle is parked rearward

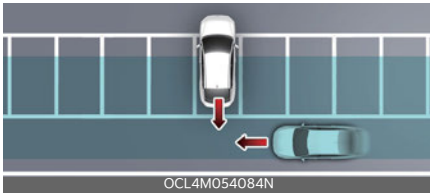

Rear Cross-Traffic Collision-Avoidance Assist may detect vehicles passing by behind you when parking in reverse into a parking space. If this occurs, the function may unnecessarily warn the driver and control the brake.

Always check your surroundings while backing up.

Traffic Collision-Avoidance Assist for safety reasons.

- Rear Cross-Traffic Collision-Avoidance Assist may not operate properly if interfered by strong electromagnetic waves.
- Rear Cross-Traffic Collision-Avoidance Assist may not operate for 3 seconds after the vehicle is started, or the rear corner radars are initialized.
- Even if restarting the vehicle with the sensors blocked or malfunctioned, Rear Cross-Traffic Collision-Avoidance Assist may not properly operate as the function maintains the last setting.

This device complies with Industry Canada licence-exempt RSS standard(s).

Operation is subject to the following two conditions:

1. This device may not cause interference, and
2. This device must accept any interference, including interference that may cause undesired operation of the device.

⚠ WARNING

- When you are towing a trailer or another vehicle, turn off Rear Cross-

Forward/Reverse Parking Distance Warning (PDW) (if equipped)

Forward/Reverse Parking Distance Warning uses the front and rear ultrasonic sensors to detect and warns you if a person, animal, or object is within a certain distance when your vehicle is stopped or driving at low speed.

Detecting sensor

Front ultrasonic sensors



Rear ultrasonic sensors



Front ultrasonic sensors (GT-Line)



Rear ultrasonic sensors (GT-Line)



Refer to the picture above for the detailed location of the detecting sensors.

Forward/Reverse Parking Distance Warning settings

Warning Methods

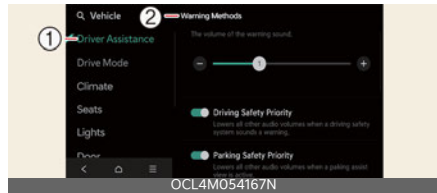

1 Driver Assistance

2 Warning Methods

The **Warning Methods** can be set with the vehicle on. Select **Setup** → **Vehicle** → **Driver Assistance** → **Warning Methods** from the settings menu in the infotainment system to change the following settings:

- **Warning Volume:** Adjusts the volume of the warning sound. If you turn off the **Warning Volume**, for your safety, the function may warn you with a low volume.

* INFORMATION

- If you change the **Warning Methods**, it can be applied to each function of the driver assistance system. Please check and change it in each function.
- If the vehicle is restarted, **Warning Methods** will maintain the last setting.

- The setting menu may not exist based on vehicle specification.

Parking Distance Warning Auto On

You can set the parking distance warning to be ON at low speeds. To use Parking Distance Warning Auto On function, select **Setup** → **Vehicle** → **Driver Assistance** → **Parking Safety** → **Parking Distance Warning Auto On** on the infotainment system.

* NOTICE

When **Parking Distance Warning Auto On** is selected, the Parking Safety button indicator (P_▲) stays on.

Forward/Reverse Parking Distance Warning operation

Parking Safety button

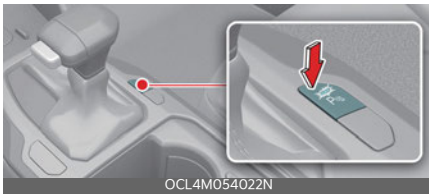

Press the Parking Safety button (P_▲) to turn on Forward/Reverse Parking Distance Warning. Press the button again to turn off the function.

- When the gear is shift to R (Reverse), Parking Distance Warning will automatically turn on (Parking Safety button indicator on).

Forward Parking Distance Warning







Forward Parking Distance Warning will operate when one of the condition is satisfied.

- The gear is shifted from R (Reverse) to D (Drive) with Reverse Parking Distance Warning on
- The gear is in D (Drive) and the Parking Safety button indicator light (P_▲) is on
- Forward Parking Distance Warning warns the driver when the vehicle is in D (Drive)
(If **Setup** → **Vehicle** → **Driver Assistance** → **Parking Safety** → **Parking Distance Warning Auto On** on the infotainment system selected)

* NOTICE

- Forward Parking Distance Warning does not operate when the vehicle's forward speed is above 10 km/h (6 mph) even when the Parking Safety button indicator (P_▲) is on. Forward Parking Distance Warning will operate again when the vehicle's forward speed decreases below 10 km/h (6 mph) while the Parking Safety button indicator (P_▲) is on.
- If **Parking Distance Warning Auto On** is not enabled, the forward Parking Distance Warning will deactivate when the vehicle speed exceeds 30 km/h (18mph) (indicated by the button turning off). The function won't automatically activate even if you drive at speeds below 10 km/h (6 mph) again.
- When in R (Reverse), the front inside warning is not activated. Only the front outside warning sound is activated when objects are within 60 cm (24 in).

Warning indication and warning sound

Distance from object	Warning indicator		Warning sound
	Cluster	Infotainment	
60-120 cm (24-48 in)			Buzzer beeps intermittently (Front inner side)
30-60 cm (12-24 in)			Beeps more frequently
Within 30 cm (12 in)			Beeps continuously







- The corresponding indicator will appear whenever each ultrasonic sensor detects a person, animal or object in its sensing range. Also, an audible warning will sound.
- When more than two objects are detected at the same time, the closest one will be warned with an audible warning.
- When the distance from the object is more than 60 cm (24 in), it is not displayed on the cluster in case of forward and outer warning.
- The shape of the indicator in the illustration may differ from the actual vehicle.

Reverse Parking Distance Warning

Reverse Parking Distance Warning will operate under the following conditions.

- The gear is shifted to R (Reverse).

Warning indication and warning sound

Distance from object	Warning indicator		Warning sound
	Cluster	Infotainment	
60-120 cm (24-48 in)			Buzzer beeps intermittently
30-60 cm (12-24 in)			Beeps more frequently
Within 30 cm (12 in)			Beeps continuously

- The corresponding indicator will appear whenever each ultrasonic sensor detects a person, animal or object in its sensing range. Also, an audible warning will sound.
- When more than two objects are detected at the same time, the closest one will be warned with an audible warning.
- The shape of the indicator in the illustration may differ from the actual vehicle.

Forward/Reverse Parking Distance Warning malfunction and precautions

Forward/Reverse Parking Distance Warning malfunction

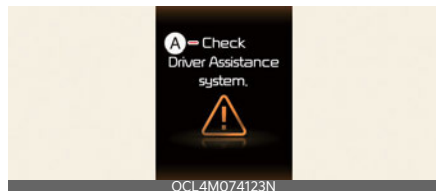

A: Check Driver Assistance system.

If there is a problem with Forward/Reverse Parking Distance Warning or

related functions and parts, a warning message is displayed on the cluster. The contents of the warning can be checked in the service message of the utility information view of the cluster display window. If it still does not work properly, have the vehicle inspected by an authorized Kia dealer.

Parking Distance Warning disabled

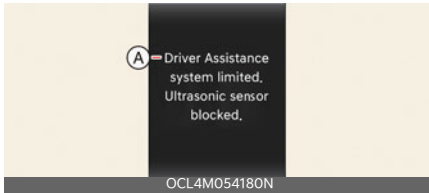

A: Driver Assistance system limited. Ultrasonic sensor blocked.

The ultrasonic sensor is a sensor that detects objects around the vehicle. The Parking Distance Warning may be temporarily limited or may not operate if snow, rain, foreign substances, etc. get on the sensor. You can check the detection sensor blind warning target (ultrasonic sensor) in the service message of the utility information view in the cluster display window.

Parking Distance Warning will work normally if you remove the contamination from the recognition sensor. Always keep it clean.

If it still does not work properly even after you have removed the contamination, have the vehicle inspected by an authorized Kia dealer.

* NOTICE

- The Master warning light (⚠) is displayed in the target direction if a malfunction or ultrasonic sensor is

blocked while Parking Distance Warning is operating.



- You can check it in the service message of the utility information view of the cluster display window.

Limitations of Forward/Reverse Parking Distance Warning

Parking Distance Warning may not operate properly when:

- Moisture is frozen to the sensor
- Sensor is covered with foreign material, such as snow or water (Parking Distance Warning will operate properly when such substance is removed.)
- The weather is extremely hot or cold
- The sensor or sensor assembly is disassembled
- The surface of the sensor is pressed hard or hit with a hard object
- The surface of the sensor is scratched with a sharp object
- The sensors or its surrounding area is directly sprayed with high pressure washer
- When objects emitting ultrasonic waves, such as a vehicle's horn, motorcycle engine, or large vehicle air brakes are nearby.

Parking Distance Warning may malfunction when:

- Heavy rain or water spray is present
- Water flows on the surface of the sensor

- Affected by another vehicle's sensors
- The sensor is covered with snow or ice
- Driving on uneven road, gravel roads or bushes
- Objects that generate ultrasonic waves are near the sensor
- License plate is installed in a different spot from the original location
- The vehicle bumper height or ultrasonic sensor installation has been modified
- Attaching equipment or accessories next to the ultrasonic sensors
- When objects emitting ultrasonic waves, such as a vehicle's horn, motorcycle engine, or large vehicle air brakes are nearby.

The following objects may not be detected:

- Sharp or slim objects, such as ropes, chains or small poles.
- Narrow objects, such as corners of a square column
- Objects, which tend to absorb sensor frequency, such as clothes, spongy material or snow.
- Objects smaller than 100 cm (40 in) in length and narrower than 14 cm (6 in) in diameter.
- Pedestrians, animals, or objects that are very close to the ultrasonic sensors

 **WARNING**

- Parking Distance Warning is a supplemental function. The operation of Parking Distance Warning can be affected by several factors (including environmental conditions). It is the responsibility of the driver to always check the front and rear views before and while parking.

- Your new vehicle warranty does not cover any accidents or damage to the vehicle due to the malfunction of Parking Distance Warning.
 - Pay close attention when driving near objects, pedestrians, and especially children. Some objects may not be detected by the ultrasonic sensors, due to the objects distance, size, or material, all of which can limit the effectiveness of the sensor.
 - Parking Distance Warning does not warn you in the order of detection. It varies depending on the speed of the vehicle or the shape of a person, animal, or object.
 - If the Parking Distance Warning does not operate properly, have the vehicle inspected by an authorized Kia dealer.
-

Forward/Side/Reverse Parking Distance Warning (PDW) (if equipped)

Forward/Side/Reverse Parking Distance Warning uses the front, side and rear ultrasonic sensors to detect and warns you if a person, animal, or object is within a certain distance when your vehicle is stopped or driving at low speed.

Detecting sensor

Front ultrasonic sensors



Front ultrasonic sensors (GT-Line)



Rear ultrasonic sensors



Rear ultrasonic sensors (GT-Line)



Front side ultrasonic sensors



Front side ultrasonic sensors (GT-Line)



Rear side ultrasonic sensors



Rear side ultrasonic sensors (GT-Line)



Refer to the picture above for the detailed location of the detecting sensors.

Forward/Side/Reverse Parking Distance Warning settings

Warning Methods

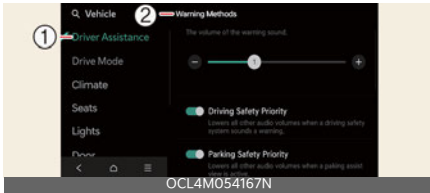

- 1 Driver Assistance
- 2 Warning Methods

The **Warning Methods** can be set with the vehicle on. Select **Setup** → **Vehicle** → **Driver Assistance** → **Warning Methods** from the settings menu in the infotainment system to change the following settings:

- **Warning Volume:** Adjusts the volume of the warning sound. If you turn off the **Warning Volume**, for your safety, the function may warn you with a low volume.

* INFORMATION

- If you change the **Warning Methods**, it can be applied to each function of the driver assistance system. Please check and change it in each function.
- If the vehicle is restarted, **Warning Methods** will maintain the last setting.
- The setting menu may not exist based on vehicle specification.

Parking Distance Warning Auto On

You can set the parking distance warning to be ON at low speeds. To use Parking Distance Warning Auto On function, select **Setup** → **Vehicle** → **Driver Assistance** → **Parking Safety** → **Parking**

Distance Warning Auto On on the infotainment system.

* NOTICE

When **Parking Distance Warning Auto On** is selected, the Parking Safety button indicator (P_{SA}) stays on.

Forward/Side/Reverse Parking Distance Warning operation

Parking Safety button



Press the Parking Safety button (P_{SA}) to turn on Forward/Side/Reverse Parking Distance Warning. Press the button again to turn off the function.

- When the gear is shift to R (Reverse), Parking Distance Warning will automatically turn on (Parking Safety button indicator on).

Forward Parking Distance Warning

Forward Parking Distance Warning will operate when one of the condition is satisfied.

- The gear is shifted from R (Reverse) to D (Drive) with Reverse Parking Distance Warning on
- The gear is in D (Drive) and the Parking safety button indicator light (P_{SA}) is on
- Forward Parking Distance Warning warns the driver when the vehicle is in D (Drive)
(If **Setup** → **Vehicle** → **Driver Assistance** → **Parking Safety** → **Parking**)

Distance Warning Auto On on the infotainment system selected)

*** NOTICE**

- Forward Parking Distance Warning does not operate when the vehicle's forward speed is above 10 km/h (6 mph) even when the Parking Safety button indicator (P) is on. Forward Parking Distance Warning will operate again when the vehicle's forward speed decreases below 10 km/h (6 mph) while the Parking Safety button indicator (P) is on.
- If **Parking Distance Warning Auto On** is not enabled, the forward Parking Distance Warning will deactivate when the vehicle speed exceeds 30 km/h (18 mph) (indicated by the button turning off). The function won't automatically activate even if you drive at speeds below 10 km/h (6 mph) again.
- When in R (Reverse), the front inside warning is not activated. Only the front outside warning sound is activated when objects are within 60 cm (24 in).

Distance from object	Warning indicator		Warning sound
	Cluster	Infotainment	
within 30 cm (12 in)			Beeps continuously

- The corresponding indicator will appear whenever each ultrasonic sensor detects a person, animal or object in its sensing range. Also, an audible warning will sound.
- When more than two objects are detected at the same time, the closest one will be warned with an audible warning.
- When the distance from the object is more than 60 cm (24 in), it is not displayed on the cluster in case of forward and outer warning.
- The shape of the indicator in the illustration may differ from the actual vehicle.

Side Parking Distance Warning

Side Parking Distance Warning will operate when one of the condition is satisfied.

- Shifting the gear to R (Reverse)
- The gear is in D (Drive) and the Parking Safety button indicator light (P) is on
- Forward Parking Distance Warning warns the driver when the vehicle is in D (Drive)

(If **Setup** → **Vehicle** → **Driver Assistance** → **Parking Safety** → **Parking Distance Warning Auto On** on the infotainment system selected)

- Your driving speed is below 10 km/h (6 mph).

Warning indication and warning sound

Distance from object	Warning indicator		Warning sound
	Cluster	Infotainment	
60~120 cm (24~48 in)			Buzzer beeps intermittently (Front inner side)
30~60 cm (12~24 in)			Beeps more frequently

*** NOTICE**

- Side Parking Distance Warning only works when the vehicle speed is below 10 km/h (6 mph).
- Side Parking Distance Warning function works only when the Forward/Reverse Parking Distance Warning function is turned on.

Reverse Parking Distance Warning

Reverse Parking Distance Warning will operate under the following conditions.

- The gear is shifted to R (Reverse).

Warning indication and warning sound

Warning indication and warning sound

Distance from object	Warning indicator		Warning sound
	Cluster	Infotainment	
60~120 cm (24~48 in)			-
30~60 cm (12~24 in)			-
within 30 cm (12 in)			Beeps continuously

- When the lateral ultrasonic sensor detects a person or object, it displays indicator lights for each distance on the cluster or infotainment system screen.
- A warning sounds when an object within 30 cm (12 in) of the side is detected in the vehicle's exit path.
- If it detects an object to the side outside the vehicle's exit path, it only displays the indicator light.
- In D (driving), when the distance from the object is 30 cm (12 in) or more, the side-way warning is not displayed on the cluster.
- The shape of the indicator may differ from the actual vehicle.

Distance from object	Warning indicator		Warning sound
	Cluster	Infotainment	
60~120 cm (24~48 in)			Buzzer beeps intermittently
30~60 cm (12~24 in)			Beeps more frequently
within 30 cm (12 in)			Beeps continuously

- The corresponding indicator will appear whenever each ultrasonic sensor detects a person, animal or object in its sensing range. Also, an audible warning will sound.
- When more than two objects are detected at the same time, the closest one will be warned with an audible warning.
- The shape of the indicator in the illustration may differ from the actual vehicle.

Forward/Side/Reverse Parking Distance Warning malfunction and precautions

Forward/Side/Reverse Parking Distance Warning malfunction

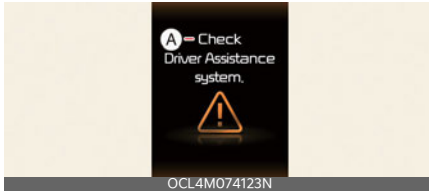

A: Check Driver Assistance system.

If there is a problem with the Parking Distance Warning or related functions and parts, a warning message is displayed on the cluster.

The contents of the warning can be checked in the service message of the utility information view of the cluster display window. If it still does not work properly, have the vehicle inspected by an authorized Kia dealer.

Parking Distance Warning disabled

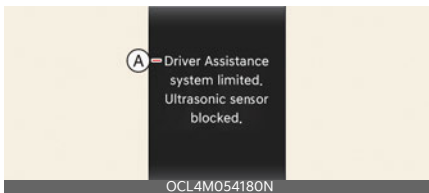

A: Driver Assistance system limited. Ultrasonic sensor blocked.

The ultrasonic sensor is a sensor that detects objects around the vehicle. The Parking Distance Warning may be temporarily limited or may not operate if snow, rain, foreign substances, etc. get on the sensor. You can check the detection sensor blind warning target (ultrasonic sensor) in the service message of

the utility information view in the cluster display window. The Parking Distance Warning will work normally if you remove the contamination from the recognition sensor. Always keep it clean. If it still does not work properly even after you have removed the contamination, have the vehicle inspected by an authorized Kia dealer.

* NOTICE

- You can check it in the service message of the utility information view of the cluster display window.
- The Master warning light (△) is displayed in the target direction if a malfunction or ultrasonic sensor is blocked while the Parking Distance Warning is operating. You can check it in the service message of the utility information view of the cluster display window.

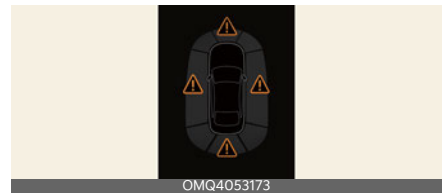

Limitations of Forward/Side/Reverse Parking Distance Warning

Parking Distance Warning may not operate properly when:

- Moisture is frozen to the sensor
- Sensor is covered with foreign material, such as snow or water (Parking Distance Warning will operate properly when such substance is removed.)
- The weather is extremely hot or cold

- The sensor or sensor assembly is disassembled
- The surface of the sensor is pressed hard or hit with a hard object
- The surface of the sensor is scratched with a sharp object
- The sensors or its surrounding area is directly sprayed with high pressure washer

Parking Distance Warning may malfunction when:

- Heavy rain or water spray is present
- Water flows on the surface of the sensor
- Affected by another vehicle's sensors
- The sensor is covered with snow or ice
- Driving on uneven road, gravel roads or bushes
- Objects that generate ultrasonic waves are near the sensor
- License plate is installed in a different spot from the original location
- The vehicle bumper height or ultrasonic sensor installation has been modified
- Attaching equipment or accessories next to the ultrasonic sensors
- When objects emitting ultrasonic waves, such as a vehicle's horn, motorcycle engine, or large vehicle air brakes are nearby.

The following objects may not be detected:

- Sharp or slim objects, such as ropes, chains or small poles.
- Narrow objects, such as corners of a square column
- Objects, which tend to absorb sensor frequency, such as clothes, spongy material or snow.

- Objects smaller than 100 cm (40 inch) in length and narrower than 14 cm (6 inch) in diameter.
- Pedestrians, animals, or objects that are very close to the ultrasonic sensors
- Objects in the side space between the front ultrasonic sensor and the rear ultrasonic sensor or approaching the side space.

WARNING

- Parking Distance Warning is a supplemental function. The operation of Parking Distance Warning can be affected by several factors (including environmental conditions). It is the responsibility of the driver to always check the front and rear views before and while parking.
- Your new vehicle warranty does not cover any accidents or damage to the vehicle due to the malfunction of Parking Distance Warning.
- Pay close attention when driving near objects, pedestrians, and especially children. Some objects may not be detected by the ultrasonic sensors, due to the objects distance, size, or material, all of which can limit the effectiveness of the sensor.
- Parking Distance Warning does not warn you in the order of detection. It varies depending on the speed of the vehicle or the shape of a person, animal, or object.
- If the Parking Distance Warning does not operate properly, have the vehicle inspected by an authorized Kia dealer.

Reverse Parking Collision-Avoidance Assist (PCA) (if equipped)

Reverse Parking Collision-Avoidance Assist detects pedestrians or objects behind the vehicle and may warn you or assist you with braking to help avoid a collision while your vehicle is reversing.

Detecting sensor

Wide-rear view camera



Rear ultrasonic sensors



Rear ultrasonic sensors (GT-Line)



Reverse Parking Collision-Avoidance Assist settings

Warning Methods

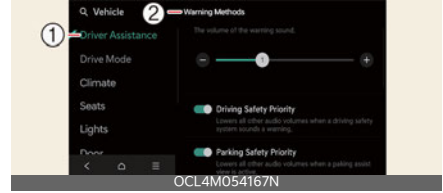

1 Driver Assistance 2 Warning Methods

The **Warning Methods** can be set with the vehicle on. Select **Setup** → **Vehicle** → **Driver Assistance** → **Warning Methods** from the settings menu in the infotainment system to change the following settings:

- **Warning Volume:** Adjusts the volume of the warning sound. If you turn off the **Warning Volume**, for your safety, the function may warn you with a low volume.

* INFORMATION

- If you change the **Warning Methods**, it can be applied to each function of the driver assistance system. Please check and change it in each function.
- If the vehicle is restarted, **Warning Methods** will maintain the last setting.
- The setting menu may not exist based on vehicle specification.

Parking Safety



1 Driver Assistance

2 Parking Safety

3 Backward Safety

With the vehicle on, touch **Setup** → **Vehicle** → **Driver Assistance** → **Parking Safety** on the infotainment system.

- **Backward Safety:** It warns or assists in braking when there is a high risk of collision with pedestrians or objects in the rear direction.

*** NOTICE**

Backward safety will be selected and Parking Collision-Avoidance Assist settings will be retained whenever the vehicle is restarted.

Reverse Parking Collision-Avoidance Assist operation

Parking Safety button

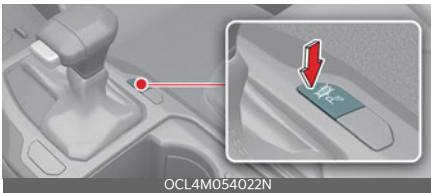

Press and hold the Parking Safety button (P) more than 2 seconds to turn the Parking Collision-Avoidance Assist on or off.

Parking Collision-Avoidance Assist

If Parking Collision-Avoidance Assist detects a risk of collision around the vehicle with a pedestrian or an object, Parking Collision-Avoidance Assist will warn the driver with an audible warning, steering wheel vibration and warning message on the instrument cluster. If the infotainment screen is on, a warning will appear on the screen. If a collision is

imminent, Parking Collision-Avoidance Assist will assist you with braking.

Operating conditions

Select **Backward safety** from the **Parking safety** menu of the infotainment system. Parking Collision-Avoidance Assist is enabled when the following conditions are satisfied:

- The trunk and doors are closed
- The Electronic Parking Brake (EPB) is released
- The gear is shifted to R (Reverse)
- Your driving speed is below 10 km/h (6 mph) (detecting pedestrians)
- Your driving speed is below 4 km/h (2 mph) (detecting objects)
- Parking Collision-Avoidance Assist components such as the wide-rear view camera and the rear ultrasonic sensors are in normal conditions

Off conditions

Braking assist is released after 5 minutes. Immediately depress the brake pedal and check vehicle surroundings. Braking assist is also released in the following conditions when:

- The gear is shifted to P (Park) or D (Drive)
- The brake pedal is depressed with sufficient power
- The warning is released when shifting to 'P' (Parking), 'N' (Neutral), or 'D' (Drive).

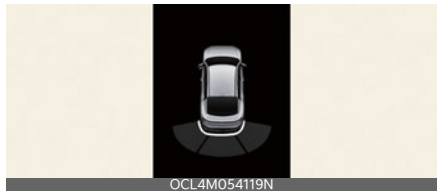

When Parking Collision-Avoidance Assist activates, a line appears behind the vehicle image in the instrument cluster.

*** NOTICE**

Parking Collision-Avoidance Assist operates only once after shifting the gear to R (Reverse). To reactivate Parking Collision-Avoidance Assist, shift the gear from another gear to R (Reverse).

*** NOTICE**

When Parking Collision-Avoidance Assist is activated while reversing, braking control will be released after 5 minutes and the Electronic Parking Brake (EPB) will be engaged.

Reverse Parking Collision-Avoidance Assist malfunction and limitations

Reverse Parking Collision-Avoidance Assist malfunction

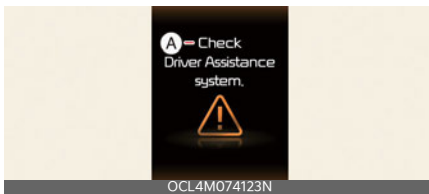

A: Check Driver Assistance system.

If there is a problem with Parking Collision-Avoidance Assist or related functions and parts, a warning message is displayed on the cluster. If it still does not work properly, have the vehicle inspected by an authorized Kia dealer.

Reverse Parking Collision-Avoidance Assist disabled

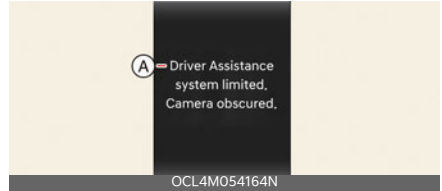

A: Driver Assistance system limited. Camera obscured.

The wide-rear view camera and rear ultrasonic sensors detect objects around the vehicle. Parking Collision-Avoidance Assist may be temporarily limited or may not operate if snow, rain, foreign substances, etc. get on the sensor. You can check the detection sensor blind warning target (wide-rear view camera, rear ultrasonic sensor) in the service message of the utility information view in the cluster display window. Parking Collision-Avoidance Assist works normally if you remove the contamination from the recognition sensor. Always keep it clean. If it still does not work properly even after decontamination is removed, have the vehicle inspected by an authorized Kia dealer.

*** NOTICE**

You can check it in the service message of the utility information view of the cluster display window.

Limitations of Reverse Parking Collision-Avoidance Assist

Parking Collision-Avoidance Assist may not assist braking or warn the driver even if there are pedestrians or objects under the following circumstances:

- There is a problem with the vehicle
 - If there is a pattern on the road

- Shadows on the ground or reflected light
- Pedestrians or objects are near the path of the vehicle
- Driving through narrow track or parking spaces
- Driving on uneven surfaces such as unpaved roads, gravel, road jaws, ramps, etc
- A trailer or carrier is installed around the rear corner radar
- Any non-factory equipment or accessory is installed
- Braking system components, such as brake discs and calipers, are modified
- Wheels are misaligned or suspension components are modified
- Accessories are attached to the steering wheel or steering components are modified
- Your vehicle is unstable due to an accident or other causes
- Bumper height or refer ultrasonic sensor installation has been modified
- If there is severe tilting of the overall height due to abnormal tire pressure or excessive loading in the cargo area
- Wide-rear view camera or ultrasonic sensor(s) is damaged
- Wide-rear view camera or the ultrasonic sensor(s) is stained with foreign material, such as snow, dirt, etc.
- A snow chain, spare tire, or wheel of a different size is installed
- There is a problem with the surroundings
 - Wide-rear view camera is obscured by a light source or by inclement weather, such as heavy rain, fog, snow, etc.
- The surrounding is very bright or very dark
- Outside temperature is very high or very low
- The wind is either strong (above 20 km/h (12 mph)) or blowing perpendicular to the rear bumper
- Objects generating excessive noise, such as vehicle horns, loud motorcycle vehicles or truck air brakes, are near your vehicle
- An object that generates ultrasonic waves is nearby
- A wireless device with a transmission function operates near the rear ultrasonic sensor
- It is affected by another vehicle's parking distance warning function
- The road is slippery or inclined
- There is a problem with pedestrians or objects
 - The pedestrians are difficult to detect
 - There is ground height difference between the vehicle and the pedestrian
 - The image of the pedestrian in the wide-rear view camera is indistinguishable from the background
 - The pedestrian is near the rear edge of the vehicle
 - The pedestrian is not standing upright
 - The pedestrian is either very short or very tall to detect
 - The pedestrian or cyclist is wearing clothing that easily blends into the background, making it difficult to detect

- The pedestrian is wearing clothing that does not reflect ultrasonic waves well
- Size, thickness, height, or shape of the object does not reflect ultrasonic waves well (for example, pole, bush, curbs, carts, edge of a wall, etc.)
- The pedestrian or the object is moving
- The pedestrian or the object is very close to the rear of the vehicle
- There is a large object such as a wall is behind the pedestrian or the object
- The object is not located at the front or rear center of your vehicle
- The object is not parallel to the rear bumper
- The face of the object is not parallel to the bumper
- There is a problem with the driving conditions
 - The driver drives the vehicle immediately after shifting to R (Reverse) or D (Drive)
 - The driver accelerates or circles the vehicle
 - The vehicle is driven immediately after starting the vehicle

WARNING

- Always pay extreme caution while driving. The driver is responsible for controlling the brake for safe driving.
- Always look around your vehicle to make sure there are no pedestrians or objects before moving the vehicle.
- The performance of Parking Collision-Avoidance Assist may vary under certain conditions. If vehicle speed is above 4 km/h (2 mph), Parking Collision-Avoidance Assist will provide collision avoidance assistance only when pedestrians are detected. Always look around and pay attention when driving your vehicle.
- Some objects may not be detected by the rear ultrasonic sensors due to the objects distance, size, or material, all of which can limit the effectiveness of the sensor.
- Parking Collision-Avoidance Assist may not operate properly or may operate unnecessarily depending on the road conditions and the surroundings.
- Do not solely rely on Parking Collision-Avoidance Assist. Doing so may lead to vehicle damage or injuries.
- Always keep the wide angle cameras and ultrasonic sensors clean.
- Do not use any cleanser containing acid or alkaline detergents when cleaning the camera lens. Use only a mild soap or neutral detergent, and rinse thoroughly with water.
- Do not spray the wide angle cameras or the rear ultrasonic sensors or their surrounding area directly with a high pressure washer. It may cause the wide angle cameras or the ultrasonic sensors to malfunction.
- Do not apply objects, such as a bumper sticker or a bumper guard, near the wide angle cameras or ultrasonic sensors or apply paint to the bumper. Doing so may adversely affect the performance of Parking Collision-Avoidance Assist.
- Never disassemble or apply impact on the wide angle cameras or the components of the ultrasonic sensor.
- Do not apply unnecessary force on the wide angle cameras or the ultra-

sonic sensors. Parking Collision-Avoidance Assist may not operate properly if the wide angle cameras or the ultrasonic sensor(s) is forcibly moved out of proper alignment. Have the vehicle inspected by an authorized Kia dealer.

- Noise may be heard when sudden braking occurs to avoid a collision.
 - If any other warning sound such as the seat belt warning chime is already generated, Parking Collision-Avoidance Assist warning may not sound.
 - Parking Collision-Avoidance Assist may not work properly if the bumper has been damaged, replaced or repaired.
 - Parking Collision-Avoidance Assist may not operate properly if interfered by strong electromagnetic waves.
 - Playing the vehicle audio system at high volume may prevent passengers from hearing Parking Collision-Avoidance Assist warning sounds.
 - The brake control may not operate properly depending on the status of ESC (Electronic Stability Control).
There will only be a warning when:
 - The ESC (Electronic Stability Control) warning light is on
 - ESC (Electronic Stability Control) is engaged in a different function
 - Check your brake fluid and brake pad conditions regularly. The brake performance may decrease depending on brake conditions.
 - Turn off Parking Collision-Avoidance Assist when towing a trailer. If towing and moving in reverse, Parking Collision-Avoidance Assist will activate as it detects the trailer.
-

* NOTICE

Parking Collision-Avoidance Assist can detect a pedestrian or an object when:

- A pedestrian is standing behind the vehicle
 - A large obstacle, such as a vehicle, is parked in the rear center of your vehicle
-

Declaration of conformity

The radio frequency components (Front Radar) complies:

For United States and United States territories



FCC ID : 2A302-MRR-35
 This device complies with Part 15 of the FCC Rules. Operation is subject to the following two conditions:
 (1) this device may not cause harmful interference, and
 (2) this device must accept any interference received, including interference that may cause undesired operation.

CAUTION TO USERS
 Changes or modifications not expressly approved by the party responsible for compliance could void the user's authority to operate the equipment.

OSG2H053295L

For Canada

Model: MRR-35
 IC: 27992-MRR35

This device complies with Industry Canada licence-exempt RSS standard(s). Operation is subject to the following two conditions:
 (1) this device may not cause interference, and
 (2) this device must accept any interference, including interference that may cause undesired operation of the device.
 Le présent appareil est conforme aux CNR d'Industrie Canada applicables aux appareils radio exempts de licence. L'exploitation est autorisée aux deux conditions suivantes:
 (1) l'appareil ne doit pas produire de brouillage, et
 (2) l'utilisateur de l'appareil doit accepter tout brouillage radioélectrique subi, même si le brouillage est susceptible d'en compromettre le fonctionnement.

OSG2H053296L

For Mexico

IFT : BLHLMR23-07397

ODL3H053018L

The radio frequency components (Front Corner Radar/Rear Corner Radar) complies: (if equipped)

For United States and United States territories



OCV051263N

This device complies with Part 15 of the FCC Rules. Operation is subject to the following two conditions:
 (1) this device may not cause harmful interference, and
 (2) this device must accept any interference received, including interference that may cause undesired operation.

CAUTION TO USERS
 Changes or modifications not expressly approved by the party responsible for compliance could void the user's authority to operate the equipment.

ODL3053154L

For Canada

Model: MBHL2
IC: 7173A-307735

NOTICE:

This device complies with Part 15 of the FCC Rules [and with RSS-210 of Industry Canada].

Operation is subject to the following two conditions:

1. This device may not cause interference.
2. This device must accept any interference, including interference that may cause undesired operation of the device.

AVIS:

L'émetteur/récepteur exempt de licence contenu dans le présent appareil est conforme aux CNR d'Innovation, Sciences et Développement économique Canada applicables aux appareils radio exempts de licence. L'exploitation est autorisée aux deux conditions suivantes :

1. L'appareil ne doit pas produire de brouillage;
2. L'appareil doit accepter tout brouillage radioélectrique subi, même si le brouillage est susceptible d'en compromettre le fonctionnement.

ODL3053155L

What to do in an emergency

Road warning	7-2
• Hazard warning flasher.....	7-2
In case of an emergency while driving	7-2
• If the vehicle stalls while driving.....	7-2
• If the engine stalls at a crossroad or crossing.....	7-2
• If you have a flat tire while driving.....	7-2
If the engine does not start	7-3
• If engine doesn't turn over or turns over slowly.....	7-3
• If engine turns over normally but does not start.....	7-3
Emergency starting	7-4
• Jump-starting.....	7-4
• Push-starting.....	7-5
If the engine overheats	7-6
Tire Pressure Monitoring System (TPMS)	7-7
• Effective use of TPMS.....	7-7
• Low tire pressure telltale.....	7-8
• TPMS malfunction indicator.....	7-9
• Tire replacement with TPMS.....	7-9
• This device complies with Industry Canada licence-exempt RSS standard(s).....	7-11
If you have a flat tire (with spare tire)	7-11
• Jack and tools.....	7-11
• Changing tires.....	7-13
• Important - use of compact spare tire.....	7-16
• Jack label.....	7-18
Towing	7-19
• Towing without wheel dollies when using a towing service.....	7-19
• Removable towing hook.....	7-20
• Emergency towing.....	7-20

What to do in an emergency

Road warning

When in an emergency situation occurs on or near roadway, you must alert approaching or passing vehicles to be careful as they pass. For this, you should use the hazard warning flasher.

Hazard warning flasher

The hazard warning flasher serves as a warning to other drivers to exercise extreme caution when approaching, overtaking, or passing your vehicle.



It should be used whenever emergency repairs are being made or when the vehicle is stopped near the edge of a roadway.

Depress the flasher switch with the ENGINE START/STOP button in any position. The flasher switch is located in the center fascia panel. All turn signal lights will flash simultaneously.

- The hazard warning flasher can be operated whether your vehicle is running or not.
- The turn signals will not operate when the hazard flasher is on.
- Care must be taken when using the hazard warning flasher while the vehicle is being towed.

In case of an emergency while driving

If an emergency occurs while driving, stay calm and take the following steps.

If the vehicle stalls while driving

1. Reduce your speed gradually, keeping a straight line.
2. Move cautiously off the road to a safe place.
3. Turn on your hazard warning flasher.
4. Try to start the vehicle again. If it will not start, contact an authorized Kia dealer or seek other qualified assistance.

If the engine stalls at a crossroad or crossing

- If the engine stalls at a crossroad or crossing, set the shift lever in the N (Neutral) position and then push the vehicle to a safe place.

If you have a flat tire while driving

1. Take your foot off the accelerator pedal and let the vehicle slow down while driving straight ahead.

Do not immediately apply the brakes or attempt to pull off the road. You may lose control.

2. When the vehicle has slowed to such a speed that it is safe to do so, brake carefully and pull off the road.
3. Drive off the road as far as possible and park on firm level ground.

If you are on a divided highway, do not park in the median area between the two traffic lanes.

4. When the vehicle is stopped, turn on your emergency hazard flashers, set the parking brake and put the transmission in P.

5. Have all passengers exit the vehicle. Be sure they all exit on the side of the vehicle that is away from traffic.
6. When changing a flat tire, follow the instruction provided later in this section for "If you have a flat tire (with spare tire)" on page 7-11.

*** NOTICE**

If there was a check engine light and loss of power or stall and if safe to do so, wait at least 10 seconds to restart the vehicle after it stalls. This may reset the car so it will no longer run at low power (limp home) condition.

If the engine does not start

When the engine doesn't start, first check to see how much fuel there is and whether the battery is discharged.

If engine doesn't turn over or turns over slowly

1. Be sure the shift lever is in N (Neutral) or P (Park) and the emergency brake is set.
2. Check the battery connections to be sure they are clean and tight.
3. Turn on the interior light. If the light dims or goes out when you operate the starter, the battery is discharged.
4. Check the starter connections to be sure they are securely tightened.

⚠ WARNING

Push/pull start

Do not push or pull the vehicle to start it. This could cause damage to your vehicle. Refer to "Jump-starting" on page 7-4.

If engine turns over normally but does not start

1. Check the fuel level and add fuel if necessary.
2. With the ENGINE START/STOP button in the OFF position, check all connectors at the ignition coils and spark plugs. Reconnect any that may be disconnected or loose.
3. Check the fuel line in the engine compartment.
4. If the engine still does not start, call an authorized Kia dealer or seek other qualified assistance.

Emergency starting

When the vehicle will not start because of low battery power, you may need to jump start the vehicle.

Jump-starting

Connect cables in numerical order and disconnect in reverse order.

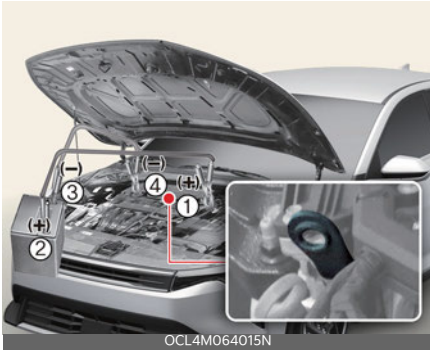

Jump-starting can be dangerous if done incorrectly. To avoid harm to yourself or damage to your vehicle or battery, follow these jump-starting procedures. If in doubt, have a competent technician or towing service jump-start your vehicle.

CAUTION

Push/pull start to 12 Volt Battery

Use only a 12-volt jumper system. You can damage a 12-volt starting motor, ignition system and other electrical parts beyond repair by use of a 24- volt power supply (either two 12-volt batteries in series or a 24-volt motor generator set).

WARNING

Battery

- Never attempt to check the electrolyte level of the battery, as this may cause the battery to rupture or explode.
- Keep all flames or sparks away from the battery. The battery produces

hydrogen gas which may explode if exposed to flame or sparks.

If these instructions are not followed exactly, serious personal injury and damage to the vehicle may occur! If you are not sure how to follow this procedure, seek qualified assistance. Automobile batteries contain sulfuric acid. This is poisonous and highly corrosive. When jump-starting, wear protective glasses and be careful not to get acid on yourself, your clothing or on the vehicle.

- Do not attempt to jump start the vehicle if the discharged battery is frozen or if the electrolyte level is low; the battery may rupture or explode.
- Do not allow the (+) and (-) jumper cables to touch. It may cause sparks.
- The battery may rupture or explode when you jump start with a low or frozen battery.

WARNING

Frozen batteries

Do not attempt to jump start the vehicle if the discharged battery is frozen, as the battery may rupture or explode.

WARNING

Battery

Keep all flames or sparks away from the battery. The battery produces hydrogen gas, which will explode if exposed to flame or sparks.

WARNING

Battery cables

Do not connect the jumper cable from the negative terminal of the booster battery to the negative terminal of the dis-

charged battery, directly. This can cause the discharged battery to overheat and crack or degrade. Make sure to connect one end of the jumper cable to the negative terminal of the booster battery, and the other end to a metallic point, far away from the battery.

WARNING

Sulfuric acid risk

Automobile batteries contain sulfuric acid. When jump-starting your vehicle, be careful not to get sulfuric acid on yourself, your clothing, or on the vehicle. This acid is poisonous and highly corrosive.

Jump-starting

1. Make sure the booster battery is 12-volt and that its negative terminal is grounded.
If the booster battery is in another vehicle, do not allow the vehicles to come in contact.
2. Turn off all unnecessary electrical loads.
3. Connect the jumper cables in the exact sequence shown in the illustration.
 - 1) Connect one end of a jumper cable to the positive terminal of the discharged battery (1).
 - 2) Connect the other end to the positive terminal of the booster battery (2).
 - 3) Proceed to connect one end of the other jumper cable to the negative terminal of the booster battery (3), then the other end to a solid, stationary, metallic point away from the battery (4).

Do not allow the jumper cables to contact anything except the correct battery terminals or the correct ground. Do not lean over the battery when making connections.

4. Start vehicle with the booster battery and let it run at 2,000 rpm, then start the vehicle with the discharged battery.

If the cause of your battery discharging is not apparent, you should have your vehicle checked by an authorized Kia dealer.

NOTICE

Battery cables

Do not connect the jumper cable from the negative terminal of the booster battery to the negative terminal of the discharged battery. This can cause the discharged battery to overheat and crack, releasing battery acid.

Make sure to connect one end of the jumper cable to the negative terminal of the booster battery, and the other end to a metallic point, far away from the battery.

Push-starting

Vehicles equipped with automatic transmission cannot be push-started, and only jump-starting can be applied. Follow the directions in this section for "Jump-starting" on page 7-4.

WARNING

Tow starting vehicle

Never tow a vehicle to start it.

When the engine starts, the vehicle can suddenly surge forward and could cause a collision with the tow vehicle.

If the engine overheats

If your temperature gauge indicates overheating, you experience a loss of power, or hear a loud pinging or knocking, the engine is probably too hot.

You should:

1. Pull off the road and stop as soon as it is safe to do so.
2. Place the shift lever in P and set the parking brake.
3. If the air conditioning is on, turn it off.
4. If engine coolant is leaking under the vehicle or steam is coming out from underneath the hood, stop the engine. Do not open the hood until the coolant has stopped leaking or the steam has stopped.
5. If there is no visible loss of engine coolant and no steam, leave the engine running and check to be sure the engine cooling fan is operating.
 - 1) If the fan is not operating, turn the engine off.
6. Check to see if the water pump drive belt is missing.
 - 1) If it is present, check to see that it is tight.
 - 2) If the drive belt seems to be satisfactory, check for coolant leaking from the radiator, hoses or under the vehicle. (If the air conditioning had been in use, it is normal for cold water to drain from it when you stop).

WARNING

Under the hood



While the engine is running, keep hair, hands and clothing away from moving parts, such as the



fan and drive belts, to prevent injury.

7. If the water pump drive belt is broken or engine coolant is leaking out, stop the engine immediately and call the nearest authorized Kia dealer for assistance.
8. If you cannot find the cause of the overheating, wait until the engine temperature has returned to normal. If coolant has been lost, carefully add coolant to the reservoir to bring the fluid level in the reservoir up to the halfway mark.
9. Proceed with caution, keeping alert for further signs of overheating. If overheating happens again, call an authorized Kia dealer for assistance.

WARNING

Engine coolant reservoir cap



Do not remove the engine coolant reservoir cap when the engine is hot. This may result in coolant being blown out of the opening and cause serious burns.

CAUTION

- Serious loss of coolant indicates there is a leak in the cooling system and this should be checked as soon as possible by an authorized Kia dealer.
- When the engine overheats from low engine coolant, suddenly adding engine coolant may cause cracks in the engine. To prevent damage, add engine coolant slowly in small quantities.

Tire Pressure Monitoring System (TPMS)

The Tire Pressure Monitoring System (TPMS) detects the pressure of vehicle's tires and displays it on the LCD display.

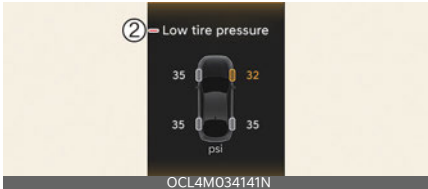

- 1 Low tire pressure telltale / TPMS malfunction indicator
- 2 Low tire pressure position telltale (shown on the LCD display) This is a normal occurrence, due to the change in tire pressure along with tire temperature.

Tire Pressure Indicator

- You can check the tire pressure in the information mode on the cluster.
 - Refer to "LCD display modes" on page 4-67.
- Tire pressure is displayed 1-2 minutes later after driving.
- If tire pressure is not displayed when the vehicle is stopped, "Drive to display" message displays. After driving, check the tire pressure.

* NOTICE

- The tire pressure may change due to factors such as parking condition,

driving style, and altitude above sea level.

- The tire pressure shown on the dashboard may differ from the tire pressure measured by tire pressure gauge.
- Low tire pressure warning may sound when a tire's pressure unit is equal or lower than nearby tires. This is a normal occurrence, due to the change in tire pressure along with tire temperature.

Effective use of TPMS

⚠ WARNING

Over-inflation or under-inflation can reduce tire life, adversely affect vehicle handling, and lead to sudden tire failure that may cause loss of vehicle control resulting in an accident

Each tire, including the spare (if provided), should be checked monthly when cold and inflated to the inflation pressure recommended by the vehicle manufacturer on the vehicle placard or tire inflation pressure label.

(If your vehicle has tires of a different size than the size indicated on the vehicle placard or tire inflation pressure label, you should determine the proper tire inflation pressure for those tires.)

As an added safety feature, your vehicle has been equipped with a tire pressure monitoring system (TPMS) that illuminates a low tire pressure telltale when one or more of your tires is significantly under-inflated. Accordingly, when the low tire pressure telltale illuminates, you should stop and check your tires as soon as possible, and inflate them to the proper pressure. Driving on a significantly under-inflated tire causes the tire

to overheat and can lead to tire failure. Under-inflation also reduces fuel efficiency and tire tread life, and may affect the vehicle’s handling and stopping ability.

Please note that the TPMS is not a substitute for proper tire maintenance, and it is the driver’s responsibility to maintain correct tire pressure, even if under-inflation has not reached the level to trigger illumination of the TPMS low tire pressure telltale.

Your vehicle has also been equipped with a TPMS malfunction indicator to indicate when the system is not operating properly. The TPMS malfunction indicator is combined with the low tire pressure telltale. When the system detects a malfunction, the telltale will flash for approximately one minute and then remain continuously illuminated. This sequence will continue upon subsequent vehicle start-ups as long as the malfunction exists. When the malfunction indicator is illuminated, the system may not be able to detect or signal low tire pressure as intended. TPMS malfunctions may occur for a variety of reasons, including the installation of replacement or alternate tires or wheels on the vehicle that prevent the TPMS from functioning properly.

Always check the TPMS malfunction telltale after replacing one or more tires or wheels on your vehicle to ensure that the replacement or alternate tires and wheels allow the TPMS to continue to function properly.

*** NOTICE**

If any of the below occurs, have the system checked by an authorized Kia dealer:

1. The low tire pressure telltale/TPMS malfunction indicator does not illuminate for 3 seconds when the ENGINE START/STOP button is turned to the ON position or engine is running.
2. The TPMS malfunction indicator remains illuminated after blinking for approximately 1 minute.
3. The Low tire pressure position telltale remains illuminated.

Low tire pressure telltale (!)

Low tire pressure position telltale

When the TPMS warning indicators appear, one or more of your tires are significantly underinflated.

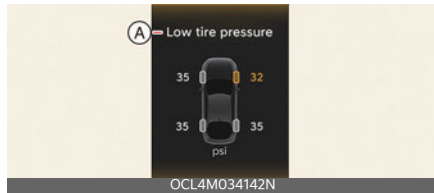

A: Low tire pressure

If the telltale illuminates, immediately reduce your speed, avoid hard cornering and anticipate increased stopping distances. Stop and check your tires as soon as possible.

Inflate the tires to the proper pressure as indicated on the vehicle’s placard or tire inflation pressure label located on the driver’s side center pillar outer panel. If you cannot reach a service station or if the tire cannot hold the newly added air, replace the low pressure tire with the spare tire.

Then the TPMS malfunction indicator and the Low Tire Pressure telltale may turn on and illuminate after restarting and about 20 minutes of continuous driving before you have the low pres-

sure tire repaired and replaced on the vehicle.

In winter or cold weather, the low tire pressure telltale may be illuminated if the tire pressure was adjusted to the recommended tire inflation pressure in warm weather. It does not mean your TPMS is malfunctioning because the decreased temperature leads to a proportional lowering of tire pressure.

You should check the tire inflation pressure and adjust the tires to the recommended tire inflation pressure when driving your vehicle in the following conditions.

- from a warm area to a cold area
- from a cold area to a warm area
- the outside temperature is extremely high or low

When filling tires with more air, conditions to turn off the low tire pressure telltale may not appear. This is because of its performance margin of error. The low tire pressure telltale will turn off when the tire pressure is above the recommended tire inflation pressure.

⚠ WARNING

Low pressure damage

Do not drive on low pressure tires. Significantly low tire pressure can cause the tires to overheat and fail, making the vehicle unstable, resulting in increased braking distances and a loss of vehicle control.

TPMS malfunction indicator (⚠)

The low tire pressure telltale will illuminate after it blinks for approximately one minute when there is a problem with the TPMS.

If the system can correctly detect an underinflation warning at the same time as system failure, it will appear both the TPMS malfunction and the low tire pressure position telltales (e.g., if the Front Left sensor fails, the TPMS malfunction indicator appears, but if the Front Right, Rear Left, or Rear Right tire is underinflated, the low tire pressure position telltales may appear together with the TPMS malfunction indicator.)

Have the system checked by an authorized Kia dealer as soon as possible to determine the cause of the problem.

- The TPMS malfunction indicator may be appeared if the vehicle is moving around electric power supply cables or radios transmitters such as near police stations, government and public offices, broadcasting stations, military installations, airports, or transmitting towers, etc.
- The TPMS malfunction indicator may illuminate if the vehicle is equipped with snow chains or some personal electronic devices (such as a laptop computer, mobile charger, remote starter or navigation) are being used in the vehicle. These can interfere with normal operation of the TPMS.

Tire replacement with TPMS

If you have a flat tire, the Low Tire Pressure telltale will come on. Have the flat tire repaired by an authorized Kia dealer as soon as possible or replace the flat tire with the spare tire.

⚠ CAUTION

Repair Agents

Never use a puncture-repairing agent not approved by Kia to repair and/or inflate a low pressure tire. Sealant that is

not approved by Kia may damage the tire pressure sensor.

Each wheel is equipped with a tire pressure sensor mounted inside the tire behind the valve stem. You must use TPMS specific wheels. Have always your tires serviced by an authorized Kia dealer.

Even if you replace the low pressure tire with the spare tire, the Low Tire Pressure telltale will remain on until the low pressure tire is repaired and placed on the vehicle.

After you replace the low pressure tire with the spare tire, the TPMS malfunction indicator may illuminate after a few minutes. This is because the TPMS sensor mounted on the spare wheel is not yet activated.

Once the low pressure tire is inflated again to the recommended pressure and installed on the vehicle or the TPM sensor mounted on the replaced spare wheel is initiated by an authorized Kia dealer, the TPMS malfunction indicator and the low tire pressure telltale will turn off within a few minutes of driving.

If the indicator has not disappeared after a few minutes of driving, please visit an authorized Kia dealer.

If an original mounted tire is replaced with the spare tire, the TPMS sensor on the replaced spare wheel should be initiated and the TPMS sensor on the original mounted wheel should be deactivated. If the TPMS sensor on the original mounted wheel located in the spare tire carrier still activates, the Tire Pressure Monitoring System may not operate properly. Have the tire with TPMS serviced or replaced by an authorized Kia dealer.

You may not be able to identify a low tire by simply looking at it. Always use a good quality tire pressure gauge to measure the inflation pressure. Please note that a tire that is hot (from being driven) will have a higher pressure measurement than a tire that is cold (from sitting stationary for at least 3 hours and driven less than 1.6 km (1 mile) during that 3-hour period).

Allow the tire to cool before measuring the inflation pressure. Always be sure the tire is cold before inflating to the recommended pressure.

A cold tire means the vehicle has been sitting for 3-hours and driven for less than 1.6 km (1 mile) in that 3 hour period. Never use tire sealant if your vehicle is equipped with a TPMS. The liquid sealant can damage the tire pressure sensors.

- The TPMS cannot alert you to severe and sudden tire damage caused by external factors such as nails or road debris.
- If you feel any vehicle instability, immediately take your foot off the accelerator, apply the brakes gradually and with light force, and slowly move to a safe position off the road.

*** NOTICE**

Protecting TPMS

Tampering with, modifying, or disabling the Tire Pressure Monitoring System (TPMS) components may interfere with the system's ability to warn the driver of low tire pressure conditions and/or TPMS malfunctions. Tampering with, modifying, or disabling the Tire Pressure Monitoring System (TPMS) components may void the warranty for that part of

the vehicle. Park on a firm level surface and apply the parking brake firmly.

This device complies with Industry Canada licence-exempt RSS standard(s).

Operation is subject to the following three conditions:

1. This device may not cause interference, and
2. This device must accept any interference, including interference that may cause undesired operation of the device.
3. Changes or modifications not expressly approved by the party responsible for compliance could void the user's authority to operate the device.

If you have a flat tire (with spare tire)

If you have a flat tire, you can change the flat tire to a spare tire using tools.

⚠ WARNING

Driving on a flat tire will cause permanent damage to the tire. Re-inflating a tire after it has been driven on while severely underinflated or flat may cause a blowout and a serious crash. Never attempt to re-inflate a tire that has been driven on while severely underinflated or flat. In this case, repair or replace the flat tire as soon as possible.

⚠ WARNING

Changing a tire can be dangerous. Follow the instructions in this section when changing a tire to reduce the risk of serious injury or death.

⚠ CAUTION

Be careful as you use the jack handle to stay clear of the flat end. The flat end has sharp edges that could cause cuts.

Jack and tools

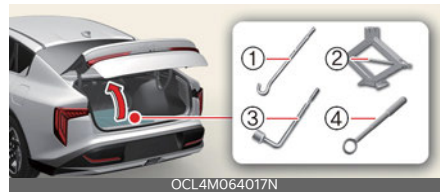

- 1 Jack
- 2 Jack handle
- 3 Wheel lug nut wrench
- 4 Towing hook

The jack, jack handle, wheel lug nut wrench, and towing hook are stored in

the luggage compartment under the luggage box cover.

Pull up the luggage box cover to reach this equipment.

Jacking instructions

The jack is provided for emergency tire changing only.

- To prevent the jack from "rattling" while the vehicle is in motion, store it properly.
- Follow jacking instructions to reduce the possibility of personal injury.

⚠ WARNING

Changing tires

- Never attempt vehicle repairs in the traffic lanes of a public road or highway.
- Always move the vehicle completely off the road and onto the shoulder before trying to change a tire. The jack should be used on firm level ground. If you cannot find a firm level place off the road, call a towing service company for assistance.
- Be sure to use the correct front and rear jacking positions on the vehicle; never use the bumpers or any other part of the vehicle for jacking support.
- The vehicle can roll off the jack causing serious injury or death.
- Do not go under a vehicle that is supported by a jack.
- Do not start or run the engine while the vehicle is on the jack.
- Do not allow anyone to remain in the vehicle while it is on the jack.
- Make sure any children present are in a secure place, away from the road and from the vehicle to be raised with the jack.

⚠ WARNING

Tire jack

Do not place any portion of your body under a vehicle that is only supported by a jack since the vehicle can easily roll off the jack. Use vehicle support stands.

⚠ WARNING

Changing tires

Never attempt vehicle repairs in the traffic lanes of a public road or highway.

⚠ WARNING

Running vehicle on jack

Do not start or run the engine of the vehicle while the vehicle is on the jack as this may cause the vehicle to fall off the jack.

To prevent the jack from "rattling" while the vehicle is in motion, store it properly.

* NOTICE

Retreaded tires

Substantial design variations and the age of the retreaded tire casing structure can limit service life and have negative impact on road safety.

Removing and storing the spare tire



- Turn the tire hold-down wing bolt counterclockwise to remove.

- Store the tire in the reverse order of removal.
- To prevent the spare tire and tools from "rattling" while the vehicle is in motion, store them properly.

⚠ WARNING

Touching surface of the luggage room floor

Do not touch the metal surface of the luggage room floor while the engine is operating or hot. Doing so could result in serious bodily injury.

Turn the engine off and wait until it cools down or wear gloves to remove the spare tire from the luggage room.

If it is hard to loosen the tire hold down wing bolt by hand, you can loosen it easily using the jack handle.

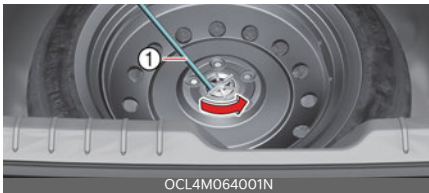

- Put the jack handle (1) inside the tire hold-down wing bolt.
- Turn the tire hold-down wing bolt counterclockwise with the jack handle. Use caution when utilizing the sharp jack handle.

Changing tires

⚠ WARNING

A vehicle can slip or roll off of a jack causing serious injury or death to you or those nearby. Take the following safety precautions:

- Never place any portion of your body under a vehicle that is supported by a jack.

- NEVER attempt to change a tire in the lane of traffic. ALWAYS move the vehicle completely off the road on level, firm ground away from traffic before trying to change a tire. If you cannot find a level, firm place off the road, call a towing service for assistance.
- Be sure to use the jack provided with the vehicle.
- ALWAYS place the jack on the designated jacking positions on the vehicle and NEVER on the bumpers or any other part of the vehicle for jacking support.
- Do not start or run the engine while the vehicle is on the jack.
- Do not allow anyone to remain in the vehicle while it is on the jack.
- Keep children away from the road and the vehicle.

1. Park on a level surface and apply the parking brake firmly.
2. Place the transmission shift lever in P (Park).
3. Activate the hazard warning flashers.



4. Remove the wheel lug nut wrench, jack and spare tire from the vehicle.



5. Block both the front and rear of the wheel that is diagonally opposite from the jack position.

⚠ WARNING

Jack location

To reduce the possibility of injury, be sure to only use the jack provided with the vehicle in the correct jack position; never use any other part of the vehicle for jack support.

⚠ WARNING

Changing a tire

- To prevent vehicle movement while changing a tire, always set the parking brake fully, and always block the wheel diagonally, opposite the wheel being changed.
- We recommend that the wheels of the vehicle be blocked, and that no person remain in a vehicle that is being jacked.

6. Loosen the wheel lug nuts counter-clockwise one turn each, but do not remove any nut until the tire has been raised off the ground.



7. Place the jack at the front (1) or rear (2) jacking position closest to the tire you are changing. Place the jack at the designated locations under the frame. The jacking positions are plates welded to the frame with two tabs and a raised dot to line up with the jack.



8. Insert the wheel lug nut wrench into the jack and turn it clockwise, raising the vehicle until the tire just clears the ground. This measurement is approximately 25 mm (1 mile).



Before removing the wheel lug nuts, make sure the vehicle is stable and that there is no chance for movement or slippage.

9. Loosen the wheel nuts and remove them with your fingers.
10. Slide the wheel off the studs and lay it flat so it cannot roll away.
11. To put the wheel on the hub, pick up the spare tire, line up the holes with the studs and slide the wheel onto them. If this is difficult, tip the wheel slightly and get the top hole in the wheel lined up with the top stud.
12. Move the wheel back and forth until the wheel can slide over the other studs.

Wheels may have sharp edges. Handle them carefully to avoid possible severe injury. Before putting the wheel into place, be sure that there is nothing on the hub or wheel (such as mud, tar, gravel, etc.) that prevents the wheel from fitting solidly against the hub.

⚠ WARNING

Installing a wheel

- When you install a wheel, always remove any corrosion, dirt or foreign materials present on the mounting surfaces of the wheel or the surface of the wheel hub, brake drum or brake disc that contacts the wheel. Make sure to secure any fasteners that attach the rotor to the hub so they do

not interfere with the mounting surfaces of the wheel. Installing wheels without correct metal-to-metal contact at the wheel mounting surfaces can cause the wheel nuts to loosen and the wheel to come off while your vehicle is in motion, resulting in loss of vehicle control, personal injury or death.

- Make sure the wheel makes good contact with the hub when installed. If the contact of the mounting surface between the wheel and hub is not good, the wheel nuts could come loose and cause the loss of a wheel. Loss of a wheel may result in loss of control of the vehicle.

⚠ WARNING

Wheel covers will not fit on the vehicle's compact spare. If you try to put a wheel cover on the compact spare, the cover or the spare could be damaged.

13. To install the wheel, hold it on the studs, put the wheel nuts on the studs and tighten them finger tight.
14. Move the tire to be sure it is completely seated, then tighten the nuts as much as possible with your fingers again.
15. Insert the wrench into the jack and lower the vehicle to the ground by turning the wheel nut wrench counterclockwise.
16. Position the wrench as shown in the drawing and tighten the wheel nuts. Be sure the socket is seated completely over the nut. Do not stand on the wrench handle or use an extension pipe over the wrench handle.
17. Go around the wheel, tightening every nut following the numerical

sequence shown in the image until they are all tight. Double-check the tightness of each nut.



18. After changing wheels, have an authorized Kia dealer tighten the wheel nuts to their proper torque as soon as possible.
19. To prevent the jack, wheel lug nut wrench and spare tire from rattling while the vehicle is in motion, store them properly.
20. Check the inflation pressures as soon as possible after installing the spare tire. Adjust it to the specified pressure, if necessary. Refer to "Tires and wheels" on page 8-29.

Wheel nut tightening torque:

11-13 kgf·m (79-94 lbf·ft)

If you have a tire gauge, remove the valve cap and check the air pressure. If the pressure is lower than recommended, drive slowly to the nearest service station and inflate to the recommended pressure. If it is too high, adjust it until it becomes appropriate. Always reinstall the valve cap after checking or adjusting the tire pressure. If the cap is not replaced, dust and dirt may get into the tire valve and air may leak from the tire. If you lose a valve cap, buy another and install it as soon as possible.

After you have changed the wheels, always secure the flat tire in its place and return the jack and tools to their proper storage locations.

⚠ CAUTION

Reusing lug nuts

Make certain during wheel removal that the same nuts that were removed are reinstalled - or, if replaced, that nuts with metric threads and the same chamfer configuration are used. Your vehicle has metric threads on the wheel studs and nuts. Installation of a non-metric thread nut on a metric stud will not secure the wheel to the hub properly and will damage the stud so that it must be replaced.

Note that most lug nuts do not have metric threads. Be sure to use extreme care in checking for thread style before installing aftermarket lug nuts or wheels. If in doubt, consult an authorized Kia dealer.

⚠ WARNING

Wheel studs

If the studs are damaged, they may lose their ability to retain the wheel. This could lead to the loss of the wheel and a collision resulting in serious injuries.

⚠ WARNING

Never use oil or grease on bolts or nuts because the nuts might come loose. The vehicle's wheel could fall off, causing a crash.

Important - use of compact spare tire (if equipped)

Your vehicle is equipped with a compact spare tire. This compact spare tire takes up less space than a regular-size tire. This tire is smaller than a conventional tire and is designed for temporary use only.

- You should drive carefully when the compact spare is in use. The compact spare should be replaced by the proper conventional tire and rim at the first opportunity.
- The operation of this vehicle is not recommended with more than one compact spare tire in use at the same time.

⚠ WARNING

Spare tire

The compact spare tire is for emergency use only. Do not operate your vehicle on this compact spare at speeds over 80 km/h (50 mph). The original tire should be repaired or replaced as soon as possible to avoid failure of the spare, possibly leading to bodily injury or death.

The compact spare should be inflated to 420 kPa(60 psi).

*** NOTICE**

Check the inflation pressure after installing the spare tire. Adjust it to the specified pressure as necessary.

When using a compact spare tire, observe the following precautions:

- Do not exceed 50 km/h (30 mph); a higher speed could damage the tire.
- Ensure that you drive slowly enough for the road conditions to avoid all hazards. Any road hazard, such as a pothole or debris, could seriously damage the compact spare.
- Continuous road use of this tire could result in tire failure, loss of vehicle control, and possible personal injury.
- Do not exceed the vehicle's maximum load rating or the load-carrying capacity shown on the sidewall of the compact spare tire.

- Avoid driving over obstacles. The compact spare tire diameter is smaller than the diameter of a conventional tire and reduces the ground clearance approximately 25 mm (1 inch), which could result in damage to the vehicle.
- Do not take this vehicle through an automatic car wash while the compact spare tire is installed.
- Do not use the compact spare tire on any other vehicle because this tire has been designed especially for your vehicle.
- The compact spare tire's tread life is shorter than a regular tire. Inspect your compact spare tire regularly and replace worn compact spare tires with the same size and design, mounted on the same wheel.
- The compact spare tire should not be used on any other wheels, nor should standard tires, snow tires, wheel covers or trim rings be used with the compact spare wheel. Damage to these items or other vehicle components may occur.
- Do not use more than one compact spare tire at a time.
- Do not tow a trailer when the compact spare tire is installed.
- Do not suddenly accelerate or decelerate (0 ↔ 40 km/h (0 ↔ 25 mph)) in any driving mode. It may cause leakage of transfer oil.

Jack label



* The actual jack label in the vehicle may differ from the illustration. For more detailed specifications, refer to the label attached to the jack.

- 1 Model Name
- 2 Maximum allowable load
- 3 When using the jack, set your parking brake.
- 4 When using the jack, stop the engine.
- 5 Do not get under a vehicle that is supported by a jack.
- 6 The designated locations under the frame
- 7 When supporting the vehicle, the baseplate of jack must be vertical under the lifting point.
- 8 Move the shift lever to the P position on vehicles with automatic transmission.
- 9 The jack should be used on firm level ground.
- 10 Jack manufacturer
- 11 Production date
- 12 Representative company and address

Towing

If emergency towing is necessary, have it done by authorized Kia dealer or a commercial tow-truck service.

Towing service

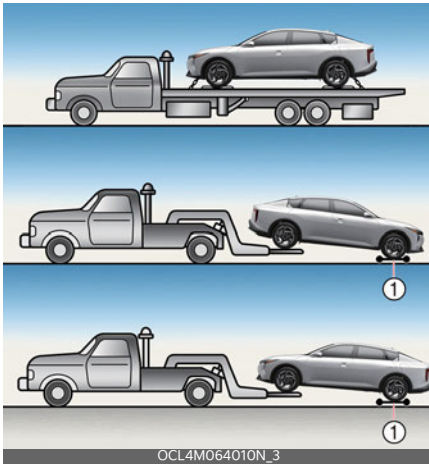

1. dollies

Proper lifting and towing procedures are necessary to prevent damage to the vehicle. The use of wheel dollies (1) or a flatbed is recommended.

It is acceptable to tow the vehicle with the non-driven wheels on the ground (without dollies) and the driven wheels off the ground. If any of the loaded wheels or suspension components are damaged or the vehicle is being towed with the driven wheels on the ground, use a towing dolly under the driven wheels. When being towed by a commercial tow truck and wheel dollies are not used, the front of the vehicle should always be lifted, not the rear.

⚠ WARNING

Side and curtain Airbag

If your vehicle is equipped with side and curtain airbag, set the ENGINE START/STOP button to ACC position when the vehicle is being towed.

The side and curtain airbag may deploy when the ENGINE START/STOP button to ON position and the rollover sensor detects the situation as a rollover.

*** NOTICE**

If the EPB does not release normally, take your vehicle to an authorized Kia dealer by loading the vehicle on a flat-bed tow truck and have the system checked.

Towing without wheel dollies when using a towing service

When towing your vehicle in an emergency without wheel dollies:

1. Set the ENGINE START/STOP button to ACC position.
2. Place the transmission shift lever in N (Neutral).
3. Release the parking brake.

⚠ CAUTION

Towing gear position

Failure to shift to N (Neutral) may cause internal damage to the vehicle.

⚠ CAUTION

Towing



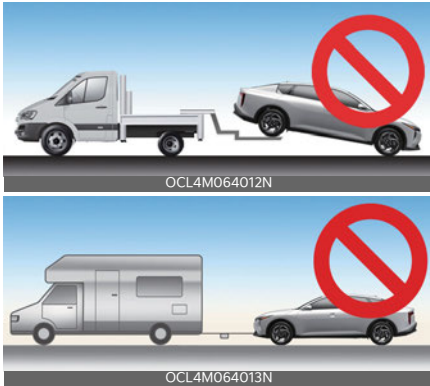

- Do not tow the vehicle backwards with the front wheels on the ground, as this may cause damage to the transmission.
- Do not tow with sling-type equipment. Use wheel lift or flatbed equipment.
- Do not tow the vehicle with four wheels in contact with the ground if it is the vehicle equipped with IVT or AT. Otherwise, the transmission will be seriously damaged. Also, make sure not to tow the vehicle connecting it with other vehicles including camper vans.

⚠ WARNING

- If you tow the vehicle while the front wheels are touching the ground, the vehicle motor may generate electricity and the motor components may be damaged or a fire may occur.
- When a fire occurs due to the battery, there is a risk of a secondary fire. Should at anytime a fire occur, immediately contact fire department.

Removable towing hook (if equipped)

Front

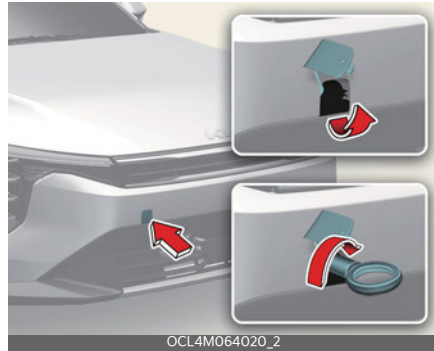

1. Open the trunk, and take out the towing hook from the tool case.
2. Remove the hole cover pressing the left part of the cover on the bumper.
3. Install the towing hook by turning it clockwise into the hole until it is fully secured.
4. Remove the towing hook and install the cover after use.

Emergency towing

Front



Rear



If towing is necessary, we recommend you to have it done by an authorized Kia dealer or a commercial tow truck service.

If towing service is not available in an emergency, your vehicle may be temporarily towed using a cable or chain secured to the emergency towing hook under the front (or rear) of the vehicle. Use extreme caution when towing the vehicle. A driver must be in the vehicle to steer it and operate the brakes.

Towing in this manner may be done only on hard-surfaced roads for a short distance and at low speed. Also, the wheels, axles, power train, steering and brakes must all be in good condition.

- Do not use the tow hooks to pull a vehicle out of mud, sand or other conditions from which the vehicle cannot be driven out under its own power.
- Avoid towing a vehicle heavier than the vehicle doing the towing.
- The drivers of both vehicles should communicate with each other frequently.

CAUTION

- Attach a towing strap to the tow hook.
- Using a portion of the vehicle other than the tow hooks for towing may damage the body of your vehicle.
- Use only a cable or chain specifically intended for use in towing vehicles. Securely fasten the cable or chain to the towing hook provided.
- Accelerate or decelerate the vehicle in a slow and gradual manner while maintaining tension on the tow rope or chain to start or drive the vehicle, otherwise tow hooks and the vehicle may be damaged.

- Before emergency towing, check if the hook is not broken or damaged.
- Fasten the towing cable or chain securely to the hook.
- Do not jerk the hook. Apply it steadily and with even force.
- To avoid damaging the hook, do not pull from the side or at a vertical angle. Always pull straight ahead.

WARNING

Use extreme caution when towing the vehicle.

- Avoid sudden starts or erratic driving maneuvers which would place excessive stress on the emergency towing hook and towing cable or chain. The hook and towing cable or chain may break and cause serious injury or damage.
- If the disabled vehicle is unable to be moved, do not forcibly continue the towing. We recommend that you contact an authorized Kia dealer or a commercial tow truck service for assistance.
- Tow the vehicle as straight ahead as possible.
- Keep away from the vehicle during towing.

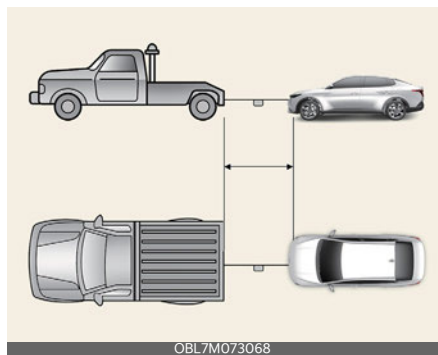

OBL7M073068

- Use a towing strap less than 16 m (5 feet) long. Attach a white or red cloth (about 30 cm wide) in the middle of the strap for easy visibility.
- Drive carefully so that the towing strap is not loosened during towing.
- The driver must be in the vehicle for steering and braking operations when the vehicle is towed and passengers other than the driver must not be allowed to be on board.

Emergency towing precautions

- Turn the ignition switch or ENGINE START/STOP button to ACC so the steering wheel isn't locked.
- Place the transmission shift lever in N (Neutral).
- Release the parking brake.
- Press the brake pedal with more force than normal since you will have reduced brake performance.
- More steering effort will be required because the power steering system will be disabled.
- If you are driving down a long hill, the brakes may overheat and brake performance will be reduced. Stop often and let the brakes cool off.
- The vehicle should be towed at a speed of 25 km/h (15 mph) or less within the distance of 20 km (12 miles).
- To avoid serious damage to the automatic transmission, limit the vehicle speed to 15 km/h (10 mph) and drive less than 1.5 km (1 mph) when towing. (for Automatic transmission and Intelligent variable transmission vehicle)

- If the car is being towed with all four wheels on the ground, it can be towed only from the front. Be sure that the transmission is in neutral. Be sure the steering is unlocked by placing the ignition switch or ENGINE START/STOP button in the ACC position. A driver must be in the towed vehicle to operate the steering and brakes.
 - Before towing, check the automatic transmission for fluid leaks under your vehicle. If the automatic transmission fluid is leaking, flatbed equipment or a towing dolly must be used.
-

CAUTION

Automatic transmission

Engine compartment	8-3
Maintenance services	8-5
Owner maintenance	8-6
Scheduled maintenance service	8-8
Explanation of scheduled maintenance items	8-12
Engine oil and filter	8-15
• Checking the engine oil level.....	8-15
• Changing the engine oil and filter.....	8-16
Engine coolant	8-17
• Checking the coolant level.....	8-18
• Changing the coolant.....	8-19
Brake fluid	8-19
• Checking the brake fluid level.....	8-19
Washer fluid	8-21
• Checking the washer fluid level.....	8-21
Air cleaner filter	8-22
• Replacing air cleaner filter.....	8-22
Climate control air filter	8-23
• Inspecting and replacing climate control air filter.....	8-23
Wiper blades	8-24
• Front windshield wiper blade.....	8-24
• Blade replacement.....	8-24
Battery	8-26
12V Parking lithium battery	8-28
Tires and wheels	8-29
• Checking tire inflation pressure.....	8-30
• Tire rotation.....	8-30
• Wheel alignment and tire balance.....	8-31
• Tire replacement.....	8-31

8 Maintenance

• Compact spare tire replacement	8-32
• Wheel replacement	8-32
• Tire traction	8-32
• Tire maintenance	8-32
• Tire sidewall labeling	8-32
• Tire terminology and definitions	8-35
• All-season tires	8-37
• Summer tires	8-37
• Snow tires	8-37
• Radial-ply tires	8-37
• Low aspect ratio tire	8-38
Fuses	8-39
• Replacing inner panel fuse	8-40
• Replacing engine compartment fuse	8-41
• Fuse/relay panel description	8-42
Light bulbs	8-49
• Replacing lights (LED type)	8-51
• Replacing turn signal lamp and stop lamp (Rear combination lamp) (Type A)	8-52
Appearance care	8-52
• Exterior care	8-52
• Interior care	8-57
Emission control system	8-59

Maintenance

Engine compartment

Smartstream G2.0

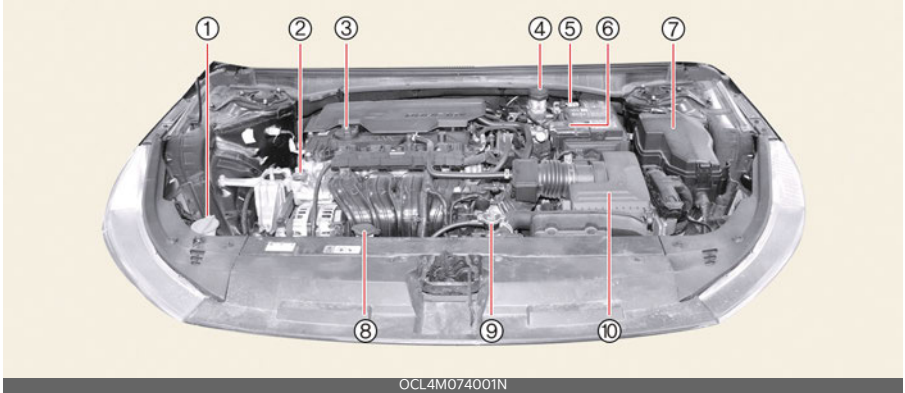

OCL4M074001N

* The actual engine compartment may differ from the illustration.

- 1 Windshield washer fluid reservoir
- 2 Engine oil dipstick
- 3 Engine oil filler cap
- 4 Brake fluid reservoir
- 5 Negative battery terminal
- 6 Positive battery terminal
- 7 Fuse box
- 8 Engine coolant reservoir
- 9 Radiator cap
- 10 Air cleaner

Smartstream G1.6 T-GDi

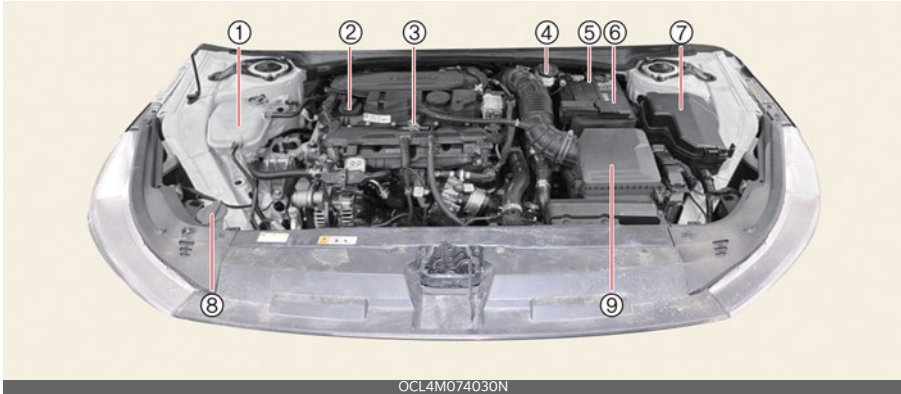

* The actual engine compartment may differ from the illustration.

- 1 Engine coolant reservoir
- 2 Brake fluid reservoir
- 3 Air cleaner
- 4 Engine oil dipstick
- 5 Engine oil filler cap
- 6 Windshield washer fluid reservoir
- 7 Fuse box
- 8 Positive battery terminal
- 9 Negative battery terminal

Maintenance services

Exercise care to prevent damage to your vehicle and injury to yourself whenever performing any maintenance or inspection procedures.

Should you have any doubts concerning the inspection or servicing of your vehicle, have an authorized Kia dealer perform this work.

An authorized Kia dealer has factory-trained technicians and genuine Kia parts to service your vehicle properly. For expert advice and quality service, see an authorized Kia dealer.

Inadequate, incomplete or insufficient servicing may result in operational problems with your vehicle that could lead to vehicle damage, an accident, or personal injury.

Owner's responsibility

* NOTICE

Maintenance Service and Record Retention are the owner's responsibility.

You should retain documents that show proper maintenance has been performed on your vehicle in accordance with the scheduled maintenance service charts shown on the following pages. You need this information to establish your compliance with the servicing and maintenance requirements of your vehicle warranties.

Detailed warranty information is provided in your Warranty & Consumer Information manual.

Repairs and adjustments required because of improper maintenance or a lack of required maintenance are not covered.

Have your vehicle maintained and repaired by an authorized Kia dealer. Repairs and adjustments required because of improper maintenance or a lack of required maintenance are not covered.

Owner maintenance precautions

Improper or incomplete service may result in problems. This section gives instructions only for the maintenance items that are easy to perform.

As explained earlier in this section, several procedures can be done only by an authorized Kia dealer with special tools.

* NOTICE

Improper owner maintenance during the warranty period may affect warranty coverage. For details, read the separate Warranty & Consumer Information manual provided with the vehicle. If you're unsure about any servicing or maintenance procedure, have it done by an authorized Kia dealer.

⚠ WARNING

Maintenance work

Do not wear jewelry or loose clothing while working under the hood of your vehicle with the engine running. These items can become entangled in moving parts, if you must run the engine while working under the hood, make certain that you remove all jewelry (especially rings, bracelets, watches, and necklaces) and all neckties, scarves, and similar loose clothing before getting near cooling fans.

WARNING

Touching metal parts

Do not touch metal parts (including strut bars) while the vehicle is operating or hot. Doing so could result in serious bodily injury. Turn the vehicle off and wait until the metal parts cool down to perform maintenance work on the vehicle.

Owner maintenance

The following lists detail the vehicle checks and inspections that should be performed by the owner or an authorized Kia dealer. They should be performed at the indicated frequencies to help ensure the safe and dependable operation of your vehicle.

Any adverse conditions should be brought to the attention of your dealer as soon as possible.

These owner maintenance checks are generally not covered by your warranty and you may be charged for labor, parts and lubricants used.

When you stop for fuel:

- Check the coolant level in coolant reservoir.
- Check the windshield washer fluid level.
- Look for low or under-inflated tires. Check if the front of the radiator and condenser are clean and not blocked with leaves, dirt or insects etc. If any of the above parts are extremely dirty or you are not sure of their condition, take your vehicle to an authorized Kia dealer.

WARNING

Hot coolant



Be careful when checking your engine coolant level when the engine is hot. Scalding hot coolant and steam may blow out under pressure.

WARNING

Engine coolant reservoir cap



Do not remove the engine coolant reservoir cap when the engine is hot. This may result in coolant being blown out of the opening and cause serious burns.

While operating your vehicle:

- Check for vibrations in the steering wheel. Notice any increased steering effort or looseness in the steering wheel or change in its straight-ahead position.
- Notice if your vehicle constantly turns slightly or "pulls" to one side when traveling on smooth, level road.
- When stopping, listen and check for unusual sounds, pulling to one side, increased brake pedal travel or "hard-to-push" brake pedal.
- If any slipping or changes in the operation of your transmission occurs, take your vehicle to an authorized Kia dealer.
- Check the P (Park) function.
- Check for fluid leaks under your vehicle (water dripping from the air conditioning system during or after use is normal).

At least monthly:

- Check the coolant level in the coolant reservoir.
- Check the operation of all exterior lights, including the stoplights, turn signals and hazard warning flashers.
- Check the inflation pressures of all tires including the spare for tires that

are worn, show uneven wear, or are damaged.

- Check for loose wheel lug nuts.

At least once every 6 months:

- Check the radiator, heater and air conditioning hoses for leaks or damage.
- Check the windshield washer spray and wiper operation. Clean the wiper blades with a clean cloth dampened with washer fluid.
- Check the headlight alignment.
- Check the lap/shoulder belts for wear and function.

At least once a year:

- Clean the body and door drain holes.
- Lubricate the door hinges and check the hood hinges.
- Lubricate the door, hood locks and latches.
- Lubricate the door rubber weatherstrips.
- Check the air conditioning system.
- Inspect and lubricate automatic transmission linkage and controls.
- Clean the battery and terminals.
- Check the brake fluid level.
- Visually inspect steering, suspension, and chassis components for damaged, loose, or missing parts or signs of wear.

Scheduled maintenance service

Follow the Normal maintenance schedule if the vehicle is usually operated where none of the following conditions apply.

Follow the Maintenance Under Severe Usage Conditions if any of the following conditions apply.

- Repeated driving short distance of less than 8 km (5 miles) in normal temperature or less than 16 km (10 miles) in freezing temperature.
- Extensive engine idling or low speed driving for long distances.
- Driving on rough, dusty, muddy, unpaved, graveled or salt-spread roads.
- Driving in areas using salt or other corrosive materials or in very cold weather.
- Driving in heavy dust condition.
- Driving in heavy traffic area.
- Driving on uphill, downhill, or mountain road repeatedly.
- Using for towing or camping and driving with loading on the roof.
- Driving as a patrol car, taxi, or other commercial use.
- Frequently driving at high speeds or with rapid acceleration/deceleration.
- Frequently driving in stop-and-go conditions.

If your vehicle is operated in any of the prior listed conditions, you should inspect, replace or refill more frequently, using the severe usage maintenance schedule instead of the normal usage maintenance schedule.

* NOTICE

Your vehicle may be equipped with the Oil Life Management System that predicts engine oil life based on the driver's driving history and alerts the driver to change engine oil.

- If the deterioration of the engine oil increases depending on the driver's driving severity, the remaining oil life alert appears on the instrument cluster before the normal engine oil replacement interval. Have the engine oil and filter be changed by an authorized Kia dealer.
- Oil Life Management System works when the recommended engine oil is used. So, if recommended engine oil is not used, replace the engine oil according to the maintenance schedule under severe usage condition. Also, check the amount of engine oil regularly as this system assumes that the engine oil is being filled normally.
- Always reset the remaining engine oil life whenever the engine oil is changed. Otherwise, the Oil Life Management System will not be correct.
- If there is no alert until the maximum maintenance interval, have vehicle be checked by an authorized Kia dealer.

* INFORMATION

The infotainment system may change after software updates. For more information, refer to the user's manual provided in the infotainment system and the quick reference guide.

Normal maintenance schedule

The following maintenance services must be performed to ensure good emission control and performance. Keep receipts for all vehicle services to protect your warranty. Where both mileage and date are shown, the frequency of service is determined by whichever occurs first.

I: Inspect and if necessary, adjust, correct, clean or replace.

R: Replace or change

		Number of months or driving distance, whichever comes first											
Months		12	24	36	48	60	72	84	96	108	120	132	144
Miles×1,000		8	16	24	32	40	48	56	64	72	80	88	96
Km×1,000		13	26	39	52	65	78	91	104	117	130	143	156
Tire rotation		Rotate every 13,000 km (8,000 miles) or 12 months											
Fuel additives ¹		Add every 13,000 km (8,000 miles) or 12 months											
Engine oil and engine oil filter ²		R	R	R	R	R	R	R	R	R	R	R	R
Climate control air filter		I	R	I	R	I	R	I	R	I	R	I	R
Air cleaner filter (Engine)		I	I	R	I	I	R	I	I	R	I	I	R
Brake fluid		Inspect every 13,000 km (8,000 miles) or 12 months Replace every 78,000 km (48,000 miles) or 48 months											
Spark plugs	Smartstream G2.0	Replace every 156,000 km (96,000 miles)											
	Smartstream G1.6 T-GDi	Replace every 78,000 km (48,000 miles)											
Coolant (Engine) ³		At first, replace at 195,000 km (120,000 miles) or 120 months. After that, replace every 39,000 km (24,000 miles) or 24 months											
Air conditioner refrigerant													
Air conditioner compressor													
12V Battery condition													
Vacuum hose													
Brake discs and pads		I	I	I	I	I	I	I	I	I	I	I	I
Brake lines, hoses and connections													
Suspension ball joints													
Steering gear rack, linkage and boots													
Exhaust system													
Cooling system													
Intercooler in/out hose, air intake hose	Smartstream G1.6 T-GDi	I	-	I	-	I	-	I	-	I	-	I	-
Drive shaft and boots													
Fuel tank and fuel cap													
Fuel tank air filter		-	I	-	I	-	I	-	I	-	I	-	I
Fuel lines, hoses and connections													
Drive belts ⁴		-	-	-	-	-	I	I	I	I	I	I	I



Number of months or driving distance, whichever comes first													
Months		12	24	36	48	60	72	84	96	108	120	132	144
Miles×1,000		8	16	24	32	40	48	56	64	72	80	88	96
Km×1,000		13	26	39	52	65	78	91	104	117	130	143	156
Intelligent Variable Transmission (IVT) fluid*	Smartstream G2.0	No service required											
Automatic transmission (AT) fluid†	Smartstream G1.6 T-GDi	No service required											

***1. Fuel additives**

If TOP TIER Detergent Gasoline is not available, one bottle of additive is recommended. Additives are available from your authorized Kia dealer along with information on how to use them. Do not mix other additives.

***2. Engine oil and engine oil filter**

As it is normal for engine oil to be consumed during driving, the engine oil level should be checked on regular basis. The engine oil change interval for normal operating conditions is based on the use of the recommended engine specification. If the recommended engine oil specification is not used, then replace the engine oil according to the maintenance schedule under severe operating conditions.

Never add any additives to the engine oil. Engine oil additives can change its properties and may cause engine failure.

***3. Coolant (Engine)**

When adding coolant, use only deionized water or soft water for your vehicle and never mix hard water in the coolant filled at the factory. An improper coolant mixture can result in serious malfunction or engine damage.

***4. Drive belts (Engine)**

Inspect alternator, water pump and air conditioner drive belt and if necessary, repair or replace. Inspect drive belt tensioner, idler and alternator pulley and if necessary correct or replace.

*** Transmission fluid**

If the vehicle has been submerged in water or in a flooded area, the fluids should be changed as a precaution.

Fuel filter (gasoline engine)

The fuel filter is normally maintenance free but periodic inspection is recommended during scheduled maintenance schedule to look for conditions caused by poor fuel quality.

- If there safety risks such as fuel flow restriction, surging, loss of power, hard starting problem etc. replace the fuel filter immediately regardless of maintenance schedule and consult an authorized Kia dealer for details.

Maintenance Under Severe Usage Conditions

The following items must be serviced more frequently on cars mainly used under severe driving conditions. Refer to the chart below for the appropriate maintenance intervals.

R: Replace

I: Inspect and if necessary, adjust, correct, clean or replace

Maintenance item		Maintenance operation	Maintenance intervals	Driving condition
Engine oil and engine oil filter		R	Every 8,000 km (5,000 miles) or 6 months	D, H, I
Automatic transmission (AT) fluid	Smartstream G1.6 T-GDi	R	Every 91,000 km (56,000 miles)	A, C, F, G, H, I, J, K
Intelligent Variable Transmission (IVT) fluid	Smartstream G2.0	R	Every 91,000 km (56,000 miles)	A, C, F, G, H, I, J, K
Climate control air filter		R	More frequently	C, E, G
Air cleaner filter		R	More frequently	C, E
Spark plugs		R	More frequently	A, B, F, G, H, I, K
Brake discs and pads and calipers		I	More frequently	C, D, E, G, H, I, J, K
Suspension ball joints		I	More frequently	C, D, E, G, H, I
Steering gear rack, linkage and boots		I	More frequently	C, D, E, F, G, H, I
Drive shafts and boots		I	More frequently	C, D, E, F, G, H, I, J

Severe Driving Conditions

A: Repeatedly driving short distance of less than 8 km (5 miles) in normal temperature or less than 16 km (10 miles) in freezing temperature.

B: Extensive engine idling or low speed driving for long distances.

C: Driving on rough, dusty, muddy, unpaved, graveled or salt-spread roads.

D: Driving in areas using salt or other corrosive materials or in very cold weather.

E: Driving in heavy dust condition.

F: Driving in heavy traffic area.

G: Driving on uphill, downhill, or mountain road repeatedly.

H: Using for towing or camping and driving with loading on the roof.

I: Driving as a patrol car, taxi, other commercial use or vehicle towing.

J: Frequently driving at high speeds or with rapid acceleration/deceleration.

K: Frequently driving in stop-and-go conditions.

Explanation of scheduled maintenance items

The following parts require scheduled maintenance.

Engine oil and filter

The engine oil and filter should be changed at the intervals specified in the maintenance schedule. If the vehicle is being driven in severe conditions, more frequent oil and filter changes are required.

Drive belts

Inspect all drive belts for evidence of cuts, cracks, excessive wear or oil saturation and replace if necessary. Drive belts should be checked periodically for proper tension and adjusted as necessary.

CAUTION

When you are inspecting the belt, place the ignition switch or ENGINE START/STOP button in the LOCK/OFF or ACC position.

Fuel filter

Kia gasoline vehicles are equipped with a lifetime fuel filter that is integrated with the fuel tank. Regular maintenance or replacement is generally not needed. This may vary depending on fuel quality. If you experience any of the following: fuel flow restriction, surging, loss of power, or a hard starting issue, inspection and, if necessary, replacement may be needed. Have the fuel filter inspected or replaced by an authorized Kia dealer.

Fuel lines, fuel hoses and connections

Check the fuel lines, fuel hoses and connections for leakage and damage. Have an authorized Kia dealer replace any damaged or leaking parts immediately.

Fuel tank and fuel cap

The fuel tank and fuel cap should be inspected at those intervals specified in the maintenance schedule. Make sure that a new fuel tank or fuel cap is correctly replaced.

Vacuum crankcase ventilation hoses

Inspect the surface of hoses for evidence of heat and/or mechanical damage. Hard and brittle rubber, cracking, tears, cuts, abrasions, and excessive swelling indicate deterioration. Particular attention should be paid to examine those hose surfaces nearest to high heat sources, such as the exhaust manifold. Inspect the hose routing to assure that the hoses do not come in contact with any heat source, sharp edges or moving components which might cause heat damage or mechanical wear. Inspect all hose connections, such as clamps and couplings, to make sure they are secure, and that no leaks are present. Hoses should be replaced immediately if there is any evidence of deterioration or damage.

Air cleaner filter

A Genuine Kia air cleaner filter is recommended when the filter is replaced.

Spark plugs

Make sure to install new spark plugs of the correct heat range.

When assembling parts, be sure to wipe the inside and outside of the boot bottom of the ignition coil and the insulator of the spark plug with a soft cloth to prevent contamination of the spark plug insulator.

⚠ WARNING

Do not disconnect and inspect spark plugs when the engine is hot. You may burn yourself.

Automatic transmission (AT) fluid

Automatic transmission fluid should not be checked under normal usage conditions. But in severe conditions, the fluid should be changed at an authorized Kia dealer in accordance to the scheduled maintenance at the beginning of this chapter (Refer to "Maintenance Under Severe Usage Conditions" on page 8-11).

* NOTICE

Automatic transmission fluid color is usually red. As the vehicle is driven, the automatic transmission fluid will begin to look darker.

It is the normal condition and you should not judge the need to replace the fluid based upon the changed color.

⚠ CAUTION

Transmission fluids

The use of a non-specified fluid could result in transmission malfunction and failure. Use only specified automatic transmission fluid. (Refer to "Recom-

mended lubricants and capacities" on page 9-9.)

Intelligent Variable Transmission (IVT) fluid

The Intelligent Variable Transmission (IVT) fluid should not be checked under normal usage conditions. But in severe conditions, the fluid should be changed at an authorized Kia dealer in accordance to the scheduled maintenance at the beginning of this chapter. (Refer to the "Scheduled maintenance service" on page 8-8.)

* NOTICE

The Intelligent Variable Transmission (IVT) fluid color is amber. As the vehicle is driven, the Intelligent Variable Transmission (IVT) fluid will begin to look darker. This is normal, and you should not judge the need to replace the fluid based upon the changed color.

⚠ CAUTION

If the genuine oil that is developed for best performance is not used, it may cause the problems of transmission performance. (Refer to the "Recommended lubricants and capacities" on page 9-9.)

WARNING

- Do not change oil
- In case of repair, use only Genuine SP-CVT1
- Ne changez pas l'huile
- En cas de réparation, utilisez uniquement SP-CVT1
- 請勿隨便更換油
- 需要維修的情況下，只能使用正品 SP-CVT1
- Масло не заменять. В случае ремонта следует использовать только оригинальное SP-CVT1

Cooling system

Check the cooling system components, such as the radiator, coolant reservoir,

hoses and connections for leakage and damage. Replace any damaged parts.

Coolant

The coolant should be changed at the intervals specified in the maintenance schedule.

Brake hoses and lines

Visually check for improper installation, chafing, cracks, deterioration or leakage. Replace any deteriorated or damaged parts immediately.

Brake fluid

Check the brake fluid level in the brake fluid reservoir. The level should be between "MIN" and "MAX" marks on the side of the reservoir. Use only hydraulic brake fluid conforming to DOT 4 specification.

Parking brake

Inspect the parking brake system including the parking brake lever (or pedal) and cables.

Exhaust pipe and muffler

Visually inspect the exhaust pipes, muffler and hangers for cracks, deterioration, or damage. Start the engine and listen carefully for any exhaust gas leakage. Tighten connections or replace parts as necessary.

Brake discs, pads and calipers

Check the pads for excessive wear, discs for run out and wear, and calipers for fluid leakage.

Suspension mounting bolts

Check the suspension connections for looseness or damage. Retighten to the specified torque.

Steering gear box, linkage and boots/lower arm ball joint

With the vehicle stopped and off, check for excessive free-play in the steering wheel.

Check the linkage for bends or damage. Check the dust boots and ball joints for deterioration, cracks, or damage. Replace any damaged parts.

Drive shafts and boots

Check the drive shafts, boots and clamps for cracks, deterioration, or damage. Replace any damaged parts and, if necessary, repack the grease.

Air conditioning refrigerant

Check the air conditioning lines and connections for leakage and damage.

Checking fluid levels

When checking engine oil, engine coolant, brake fluid, and washer fluid, always be sure to clean the area around any filler plug, drain plug, or dipstick before checking or draining any lubricant or fluid. This is especially important in dusty or sandy areas and when the vehicle is used on unpaved roads. Cleaning the plug and dipstick areas will prevent dirt and grit from entering the engine and other mechanisms that could be damaged.

Engine oil and filter

Checking the engine oil level

Engine oil is used for lubricating, cooling, and operating various hydraulic components in the engine. Engine oil consumption while driving is normal, and it is necessary to check and refill the engine oil regularly. Also, check and refill the oil level within the recommended maintenance schedule to prevent deterioration of oil performance. Check the engine oil following the below procedure.

1. Be sure the vehicle is on level ground.
2. Start the engine and allow it to reach normal operating temperature.

⚠ WARNING

Radiator hose

Be very careful not to touch the radiator hose when checking or adding the engine oil as it may be hot enough to burn you.

3. Turn the engine off, remove the oil filler cap and pull the dipstick out. Wait for 15 minutes for the oil to return to the oil pan.

Smartstream G2.0

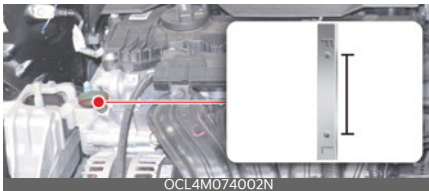

Smartstream G1.6 T-GDi



4. Wipe the dipstick clean and re-insert it fully.
5. Pull the dipstick out again and check the level. Check if the oil level is between the F-L line, and if it is below the L line, add enough oil to bring the level to F line.

⚠ CAUTION

When you wipe the oil level gauge, you should wipe it with a clean cloth. When mixed with debris, it can cause engine damage.

Smartstream G2.0



Smartstream G1.6 T-GDi



Use a funnel to help prevent oil from being spilled on engine components.

Use only the specified engine oil. (Refer to "Recommended lubricants and capacities" on page 9-9.)

- Do not spill engine oil when adding or changing engine oil. Wipe off spilled oil immediately.
- The engine oil consumption may increase while you break in a new vehicle and it will be stabilized after driving 6,000 km (4,000 miles).

- The engine oil consumption can be affected by driving habits, climate conditions, traffic conditions, oil quality, etc. Therefore, it is recommended that you inspect the engine oil level regularly and refill it if necessary.

Changing the engine oil and filter

The lubrication, rust prevention, cooling, and cleaning effect of the engine oil will gradually degrade during its use. Have the engine oil and filter changed by an authorized Kia dealer according to the Engine Oil Life Management System instructions or the maintenance schedule.

- If the maintenance schedule to replace engine oil is exceeded, the engine oil performance may deteriorate, and the engine condition may be affected. Therefore, replace the engine oil according to the maintenance schedule.
- To keep the engine in optimal condition, use the recommended engine oil and filter. If the recommended engine oil and filter are not used replace it according to the maintenance schedule under severe usage conditions.
- The purpose of the maintenance schedule for engine oil replacement is to prevent oil deterioration and it is irrelevant to oil consumption. Check and refill engine oil regularly.



WARNING

Used engine oil

Used engine oil may cause irritation or cancer of the skin if left in contact with the skin for prolonged periods of time. Always protect your skin by washing your hands thoroughly with soap and warm water as soon as possible after

handling used oil. Do not leave used engine oil within the reach of children.

NOTICE

When the oil pressure is low due to insufficient engine oil, the Engine Oil Pressure () warning light will appear. In addition, the enhanced engine protection system, which limits the engine's power is activated and the Malfunction Indicator Lamp () will appear when the vehicle is driven in this state continuously.

When the engine oil pressure is restored, the warning light and the enhanced engine protection system will turn off after the engine is restarted.

CAUTION

The engine oil is very hot immediately after the vehicle has been driven and can cause burns during replacement. Replace the engine oil after the engine oil has cooled down.

NOTICE

Never add any additives to the engine oil. Engine oil additives can change its properties and may cause engine failure.

Engine coolant

The high-pressure cooling system has a reservoir filled with year round anti-freeze coolant. The reservoir is filled at the factory.

Check the antifreeze protection and coolant level at least once a year, at the beginning of winter, and before traveling to a colder climate.

⚠ CAUTION

- When the engine overheats from low engine coolant, suddenly adding engine coolant may cause cracks in the engine. To prevent damage, add engine coolant slowly in small quantities.
- Do not drive with no engine coolant. It may cause water pump failure and engine seizure, etc.

⚠ WARNING

Engine coolant reservoir cap



Never attempt to remove the engine coolant reservoir cap while the engine is operating or hot. Doing so might lead to damage to the cooling system and engine and could result in serious bodily injury from the escaping hot coolant or steam.

Recommended coolant

When adding coolant, use only deionized water or soft water for your vehicle and never mix hard water in the coolant filled at the factory. An improper coolant mixture can result in serious malfunction or damage.

- Do not use alcohol or methanol coolant or mix them with the specified coolant.

- The engine in your vehicle has aluminum engine parts and must be protected by an ethylene-glycol with phosphate-based coolant to prevent corrosion and freezing.
- Do not use a solution that contains more than 60% antifreeze or less than 35% antifreeze, which would reduce the effectiveness of the solution.

For mixture percentage, refer to the following table.

Ambient Temperature	Mixture Percentage (volume)	
	Antifreeze	Water
-15 °C (5 °F)	35	65
-25 °C (-13 °F)	40	60
-35 °C (-31 °F)	50	50
-45 °C (-49 °F)	60	40

⚠ WARNING

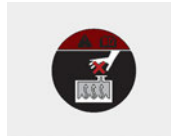

Engine coolant reservoir cap

Do not remove the engine coolant reservoir cap when the engine and engine coolant reservoir are hot. Scalding hot coolant and steam may blow out under pressure which may result in serious injury.

Smartstream G2.0



Smartstream G1.6 T-GDi

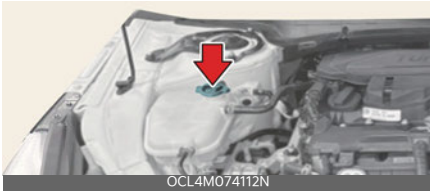

*** NOTICE**

Make sure the engine coolant reservoir cap is properly closed after refill or coolant.

The engine could be overheated while driving.

1. Check if the engine coolant reservoir cap label is straight in front.

Engine room front view



2. Make sure that the tiny protrusions inside the coolant cap are securely interlocked.

Checking the coolant level

⚠ WARNING



Removing engine coolant reservoir cap

Never attempt to remove the engine coolant reservoir cap

while the engine is operating or hot. Doing so might lead to cooling system damage and could result in serious personal injury from escaping hot coolant or steam.

1. Turn the vehicle off and wait until it cools down.
2. Use extreme care when removing the engine coolant reservoir cap. Wrap a thick towel around it and turn it counterclockwise slowly to the first stop.
3. Step back while the pressure is released from the cooling system.
4. When you are sure all the pressure has been released, press down on the cap, using a thick towel, and continue turning counterclockwise to remove it.

⚠ WARNING

Cooling fan



Use caution when working near the blade of the cooling fan. The electric motor

(cooling fan) is controlled by coolant temperature, refrigerant pressure and vehicle speed. It may sometimes operate even when the vehicle is not running.

5. Check the condition and connections of all cooling system hoses and heater hoses.
6. Replace any swollen or deteriorated hoses.
7. Check the coolant level. The coolant level should be filled between MAX and MIN marks on the side of the coolant reservoir when the engine room is cool.

Smartstream G2.0



Smartstream G1.6 T-GDi



8. If the coolant level is low, add enough specified coolant to provide protection against freezing and corrosion. Bring the level to MAX, but do not overfill.

If frequent additions are required, see an authorized Kia dealer for a cooling system inspection.

Changing the coolant

Have the coolant changed by an authorized Kia dealer according to the Maintenance Schedule, refer to "Scheduled maintenance service" on page 8-8.

CAUTION

Put a thick cloth or fabric around the engine coolant reservoir cap before refilling the coolant to prevent the coolant from overflowing into engine parts such as the alternator.

Brake fluid

The brake fluid acts to transmit force to the brake when the driver depresses the brake pedal. Brake fluid must be maintained periodically to ensure that the brakes operate smoothly.

Checking the brake fluid level

Check the fluid level in the reservoir periodically. The fluid level should be between MAX and MIN marks on the side of the reservoir.



1. Before removing the reservoir cap and adding brake fluid, clean the area around the reservoir cap thoroughly to prevent brake fluid contamination.
2. Periodically check that the fluid level in the brake fluid reservoir is between MIN and MAX. The level will fall with accumulated mileage. This is a normal condition associated with the wear of the brake linings. If the fluid level is excessively low, have the brake system checked by an authorized Kia dealer.

Use only the specified brake fluid. (Refer to "Recommended lubricants and capacities" on page 9-9.)

Never mix different types of fluid.

WARNING

In the event the brake system requires frequent additions of fluid, the vehicle should be inspected by an authorized Kia dealer.

⚠ WARNING

When changing and adding brake fluid, handle it carefully. Do not let it contact your eyes. If brake fluid should contact your eyes, immediately flush them with a large quantity of fresh tap water. Have your eyes examined by a doctor as soon as possible.

⚠ CAUTION**Proper fluid**

Only use brake fluid in the brake system. Even small amounts of improper fluids can cause damage to the brake system.

⚠ CAUTION**Brake fluid**

Do not allow brake fluid to contact the vehicle's body paint, as paint damage will result.

The brake fluid constantly absorbs moisture from the air. This lowers the boiling point of the brake fluid. If the boiling point is too low, vapor pockets may form in the brake system when the brakes are applied hard.

Brake fluid, which has been exposed to open air for an extended time should never be used as its quality cannot be guaranteed. It should be disposed of properly.

⚠ CAUTION

To maintain your vehicle's best brake and ABS/ESC performance, use Kia genuine brake fluid as in the specification. (Classification: SAE J1704 DOT-4 LV, ISO4925 CLASS-6, FMVSS116 DOT-4)

⚠ CAUTION**Washer fluid**

- Do not use radiator coolant or anti-freeze in the washer fluid reservoir. Radiator coolant can severely obscure visibility when sprayed on the windshield and may cause loss of vehicle control or damage to paint and body trim. Windshield Washer fluid agents contain some amounts of alcohol and can be flammable under certain circumstances. Do not allow sparks or flame to contact the washer fluid or the washer fluid reservoir. Damage to your vehicle or occupants could occur.
- Windshield washer fluid is poisonous to humans and animals. Do not drink and avoid contacting windshield washer fluid. Serious injury or death could occur.

Washer fluid

Washer fluid is used when wiping the windshield of the vehicle with a windshield wiper. You should check and refill washer fluid periodically to make sure that it doesn't run out.

Checking the washer fluid level



The reservoir is translucent so that you can check the level with a quick visual inspection.

- Check the fluid level in the washer fluid reservoir and add fluid if necessary. Plain water may be used if washer fluid is not available. Use washer solvent with antifreeze characteristics in cold climates to prevent freezing.

⚠ WARNING

Flammable Fluid

Do not allow the washer fluid to contact open flames or sparks. The windshield washer fluid reservoir is flammable under certain circumstances. This can result in a fire.

⚠ WARNING

Coolant

- Do not use radiator coolant or anti-freeze in the washer fluid reservoir.
- Radiator coolant can severely obscure visibility when sprayed on the windshield and may cause loss of vehicle control.

⚠ WARNING

Windshield fluid

Do not drink the windshield washer fluid. The windshield washer fluid is poisonous to humans and animals.

Air cleaner filter

Replacing air cleaner filter

Air cleaner filter must be replaced when necessary and should not be washed.



You can clean the filter when inspecting the air cleaner compartment. Clean the filter by using compressed air.

1. Pull up the lever (1) on the air cleaner cover and release the lock.



2. Pull up the air cleaner cover and open.

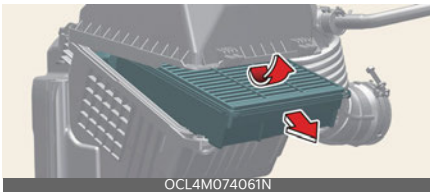

3. Rotate the fixed lever on the filter and loosen the lock.
4. Replace the air cleaner filter.
5. Assemble in reverse order.



- * Insert the hinge (1) and engage the clamp when mounting the air cleaner cover.

Replace the filter according to the Maintenance Schedule.

* NOTICE

If the vehicle is operated in extremely dusty or sandy areas, replace the element more often than the usual recommended intervals. (Refer to "Maintenance Under Severe Usage Conditions" on page 8-11.)

⚠ CAUTION

Air filter maintenance

- Do not drive with the air cleaner removed; this will result in excessive engine wear.
- When removing the air cleaner filter, be careful that dust or dirt does not enter the air intake, or damage may result.
- Use a Kia genuine part. Use of a non-genuine part could damage the air flow sensor.

Climate control air filter

The climate control air filter should be replaced according to the maintenance schedule. If the vehicle is operated in severely air-polluted cities or on dusty rough roads for a long period, it should be inspected more frequently and replaced earlier.

Inspecting and replacing climate control air filter

When you replace the climate control air filter, replace it by performing the following procedure. Be careful to avoid damaging other components:

1. Open the glove box.
2. Remove the support rod.

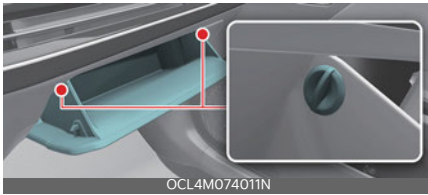

3. Push in both sides of the glove box as shown. This will ensure that the glove box stopper pins will get released from its holding location allowing the glove box to hang.

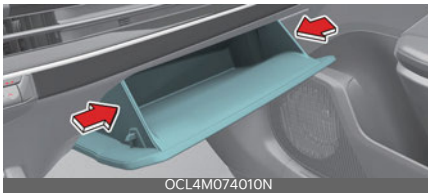

4. Remove the climate control air filter cover by pulling out right side of the cover.



5. Replace the climate control air filter.



6. Reassemble in the reverse order of disassembly.

* NOTICE

When replacing the climate control air filter install it properly. Otherwise, the system may produce noise and the effectiveness of the filter may be reduced.

Wiper blades

When the wipers no longer clean adequately, the blades may be worn or cracked, and require replacement.

To prevent damage to the wiper arms or other components, do not attempt to move the wipers manually.

The use of a non-specified wiper blade could result in a wiper malfunction and failure.

Blade inspection



* NOTICE

Commercial hot waxes applied by automatic vehicle washes have been known to make the windshield difficult to clean.

Contamination of either the windshield or the wiper blades with foreign matter can reduce the effectiveness of the windshield wipers. Common sources of contamination are insects, tree sap, and hot wax treatments used by some commercial vehicle washes. If the blades are not wiping properly, clean both the window and the blades with a good cleaner or mild detergent, and rinse thoroughly with clean water.

⚠ CAUTION

To prevent damage to the wiper blades, do not use gasoline, kerosene, paint thinner, or other solvents on or near them.

Front windshield wiper blade



This vehicle has a "hidden" wiper design which means that the wipers cannot be lifted when they are in their bottom resting position.

1. Within 20 seconds of turning off the engine, lift and hold the wiper lever up to the MIST position for about 2 seconds until the wipers move to the top wipe position.

At this time, you can lift the wipers off the windshield.

2. Gently put the wipers back down onto the windshield.
3. Turn the wipers to any ON position to return the wipers to the bottom resting position.

Blade replacement

When the wipers no longer clean adequately, the blades may be worn or cracked, and require replacement.

Operation

1. Turn off the vehicle.
2. Move the wiper switch to the single wiping (MIST/1x) position.
3. Hold the wiper switch for more than 2 seconds.

4. Type A (if equipped)

- Raise the wiper arm.
- Lift the wiper blade clip up. Pull down the blade assembly and remove it.



- Install the new blade assembly.

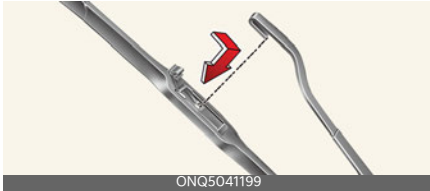

5. Type B (if equipped)

- Raise the wiper arm and turn the wiper blade assembly to expose the plastic locking clip.

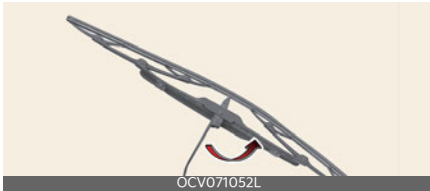

- Compress the clip and slide the blade assembly downward.



- Lift it off the arm.
- Install the blade assembly in the reverse order of removal.

- Return the wiper arm on the windshield.
- Turn the vehicle on and wiper arms will return to the normal operating position.

⚠ CAUTION

Wiper arms

- Do not allow the wiper arm to fall against the windshield, since it may chip or crack the windshield.
- Do not pull the wiper arm forward, since arm could chip hood paint.

Battery

The battery powers the engine to move the vehicle as well as supplying power to the various devices installed in the vehicle.

For best battery service



- Keep the battery securely mounted.
- Keep the battery top clean and dry.
- Keep the terminals and connections clean, tight, and coated with petroleum jelly or terminal grease.
- Rinse any spilled electrolyte from the battery immediately with a solution of water and baking soda.
- If the vehicle is not going to be used for an extended time, disconnect the battery cables.

⚠ WARNING

Risk of explosion



Keep lit cigarettes and all other flames or sparks away from the battery.



The battery contains hydrogen -- a highly combustible gas which will explode if it contacts a flame or spark.



Keep batteries out of the reach of children because batteries contain highly corrosive SULFURIC ACID and electrolytes.

Do not allow battery acid to contact your skin, eyes, clothing or paint finish.



Wear eye protection when charging or working near a battery. Always provide ventilation when working in an enclosed space.



Always read the following instructions carefully when handling a battery.



If any electrolyte gets into your eyes, flush your eyes with clean water for at least 15 minutes and get immediate medical attention. If electrolyte gets on your skin, thoroughly wash the contacted area. If you feel pain or burning sensation, get medical attention immediately.



An inappropriately disposed battery can be harmful to the environment and human health. Dispose the battery according to your local law(s) or regulation.



The battery contains lead. Do not dispose of it after use. Please return the battery to an authorized Kia dealer to be recycled.

Never attempt to recharge the battery when the battery cables are connected.

⚠ WARNING

Risk of electrocution

Never touch the electrical ignition system while the vehicle is running. This system works with high voltage, which can "zap" you.

*** NOTICE**

If you connect unauthorized electronic devices to the battery, the battery may

be discharged. Never use unauthorized devices.

⚠ WARNING

Recharging battery

Never attempt to recharge the battery when the battery cables are connected.

⚠ WARNING

Battery lead compound

Battery posts, terminals, and related accessories contain lead and lead compounds. Wash hands after handling.

*** NOTICE**

Your vehicle is equipped with a maintenance free battery. If your vehicle is equipped with the battery marked with LOWER and UPPER on the side, you can check the electrolyte level. The electrolyte level should be between LOWER and UPPER. If the electrolyte level is low, it needs to add distilled (demineralized) water (Never add sulfuric acid or other electrolyte). When refilled, be careful not to splash the battery and adjacent components. And do not overfill the battery cells. It can cause corrosion on other parts. Ensure that the cell caps are tightened. Contact an authorized Kia dealer.

Battery recharging

Your vehicle has a maintenance-free, calcium-based battery

- If the battery becomes discharged in a short time (because, for example, the headlights or interior lights were left on while the vehicle was not in use), recharge it by slow charging (trickle) for 10 hours.

- If the battery gradually discharges because of high electric load while the vehicle is being used, recharge it at 20~30 A for two hours.

When recharging the battery, observe the following precautions:

- The battery must be removed from the vehicle and placed in an area with good ventilation.
- Do not allow cigarettes, sparks, or flame near the battery.
- Watch the battery during charging, and stop or reduce the charging rate in following cases:
 1. the battery cells begin gassing (boiling) violently
 2. the electrolyte temperature of any cell exceeds 49 °C (120 °F).
- Wear eye protection when checking the battery during charging.
- Before performing maintenance or recharging the battery, turn off all accessories and stop the vehicle.
- Disconnect the battery charger in the following order.
 1. Turn off the battery charger main switch.
 2. Unhook the negative clamp from the negative battery terminal.
 3. Unhook the positive clamp from the positive battery terminal.
- The negative battery cable must be removed first and installed last when the battery is disconnected.

⚠ CAUTION

AGM battery

- Absorbent Glass Mat (AGM) batteries are maintenance free and have the AGM battery serviced by an authorized Kia dealer.

For charging your AGM battery, use only fully automatic battery chargers that are specially developed for AGM batteries.

- When replacing the AGM battery, use parts for replacement from an authorized Kia dealer.
 - Do not open or remove the cap on top of the battery. This may cause leaks of internal electrolytes that could result in severe injury.
-

Reset items

The following items should be reset after the battery has been discharged or the battery has been disconnected:

- Auto up/down window (Refer to "Window opening and closing" on page 4-43)
- Trip computer (Refer to "LCD display" on page 4-67)
- Climate control system (Refer to "Climate control system" on page 4-93)
- Sunroof (Refer to "Wide sunroof (if equipped)" on page 4-52)

12V Parking lithium battery

12V Parking lithium battery is added to secure stable operation power supply when functions such as OTA update, after-blow, and CCS are operated while parking.

12V Lithium Auxiliary Battery care

If the 12V lithium auxiliary battery detects an abnormality, such as high temperature or overcharging, a warning message is displayed in the cluster or a malfunction alert text is sent to the registered mobile phone number.

However, malfunction alert text is sent only to customers who subscribe to the Kia Connect service.

WARNING

If you receive a warning message in the cluster or a malfunction notification on your phone, have the system inspected by an authorized Kia dealer.

Tires and wheels

For proper maintenance, safety, and maximum fuel economy, you must always maintain the recommended tire inflation pressures and stay within the load limits and weight distribution recommended for your vehicle.

Recommended cold tire inflation pressures

All tire pressures should be checked when the tires are cold. "Cold Tires" means the vehicle has not been driven for at least three hours or driven less than 1.6 km (1 mile).

Recommended pressures must be maintained for the best ride, vehicle handling, and minimum tire wear.

For recommended inflation pressure, refer to "Tires and wheels" on page 9-8. All specifications (sizes and pressures) can be found on a label attached to the driver's side center pillar.



⚠ WARNING

Tire underinflation

Inflate your tires consistent with the instructions provided in this manual. Regularly check the tire inflation pressure, and correct it as needed; at least twice a month and before any long trips on the road. If you fail to observe this precaution, you may be driving on underinflated tires, which may not only compromise your vehicle's driving stability, but may also lead to tire damage and

the risk of an accident. This risk is much higher on hot days and when driving for long periods at high speeds.

Failure to maintain specified pressure may result in excessive wear, poor handling, reduced fuel economy, deformation of tire and/or wheel, harsh ride conditions, the possibility for additional damage from road hazards, or result in tire failure.

Tire pressure

Always observe the following:

- Check tire pressure when the tires are cold. (After vehicle has been parked for at least three hours or hasn't been driven more than 1.6 km (1 mile) since startup.)
- Check the pressure of your spare tire each time you check the pressure of other tires.
- Never overload your vehicle. Be careful not to overload a vehicle luggage rack if your vehicle is equipped with one.
- Warm tires normally exceed recommended cold tire pressures by 28-41 kPa (4-6 psi). Do not release air from warm tires to adjust the pressure or the tires will be underinflated.

⚠ WARNING

Tire Inflation

Overinflation or underinflation can reduce tire life, adversely affect vehicle handling, and lead to sudden tire failure. This could result in loss of vehicle control and potential injury.

Checking tire inflation pressure

Check your tires once a month or more. Use a good quality gauge to check tire pressure. You cannot tell if your tires are properly inflated simply by looking at them. Radial tires may look properly inflated even when they're underinflated.

Check the tire inflation pressure when the tires are cold. "Cold" means your vehicle has been sitting for at least three hours or driven no more than 1.6 km (1 mile).

1. Remove the valve cap from the tire valve stem.
2. Press the tire gauge firmly onto the valve to get a pressure measurement. If the cold tire inflation pressure matches the recommended pressure on the tire and loading information label, no further adjustment is necessary.
3. If the pressure is low, add air until you reach the recommended amount.
4. If you overfill the tire, release air by pushing on the metal stem in the center of the tire valve.
5. Recheck the tire pressure with the tire gauge.
6. Be sure to put the valve caps back on the valve stems. They help prevent leaks by keeping out dirt and moisture.

Inspect your tires frequently for proper inflation as well as wear and damage. Always use a tire pressure gauge.

Tires with too much or too little pressure wear unevenly. This could result in poor handling, loss of vehicle control, and sudden tire failure leading to accidents, injuries, and even death. The recommended cold tire pressure for your vehi-

cle can be found in this manual and on the tire label located on the driver's side center pillar.

Tire rotation

To equalize tread wear, it is recommended that the tires be rotated every 13,000 km (8,000 miles) or sooner if irregular wear develops.

During rotation, check the tires for correct balance.

When rotating tires, check for uneven wear and damage. Abnormal wear is usually caused by incorrect tire pressure, improper wheel alignment, out-of-balance wheels, severe braking or severe cornering. Look for bumps or bulges in the tread or side of tire. Replace the tire if you find either of these conditions. Replace the tire if fabric or cord is visible. After rotation, be sure to bring the front and rear tire pressures to specification and check lug nut tightness. (proper torque is 11-13 kgf·m [79-94 lb ft])

Refer to "Tires and wheels" on page 9-8. Disc brake pads should be inspected for wear whenever tires are rotated.

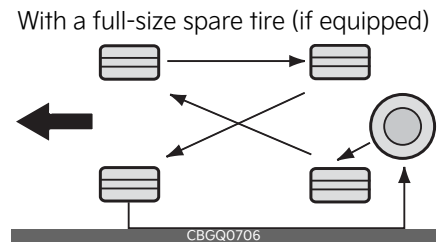

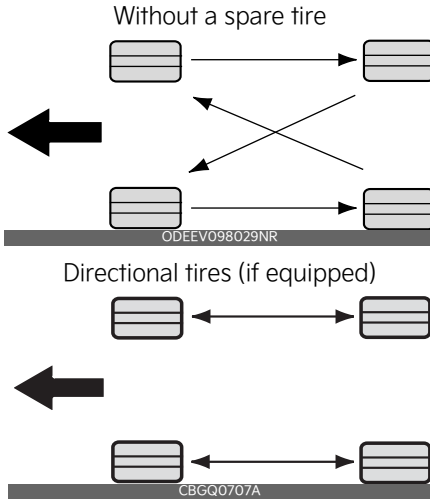

Rotate radial tires that have an asymmetric tread pattern only from front to rear and not from right to left.

⚠ WARNING

Mixing tires

- Do not use the compact spare tire for the tire rotation.
- Do not mix bias ply and radial ply tires under any circumstances. This may cause unusual handling characteristics.

Wheel alignment and tire balance

The wheels on your vehicle were aligned and balanced carefully at the factory to provide the longest tire life and best overall performance.

If you notice unusual tire wear or your vehicle pulling one way or the other, the alignment may need to be reset.

If you notice your vehicle vibrating when driving on a smooth road, your wheels may need to be rebalanced.

⚠ CAUTION

Wheel weight

Improper wheel weights can damage your vehicle's aluminum wheels. Use only approved wheel weights.

Tire replacement

If the tire is worn evenly, a tread wear indicator (A) will appear as a solid band across the tread.

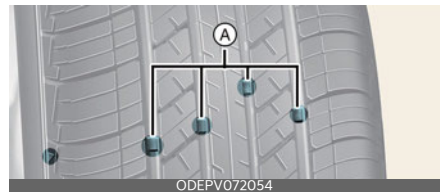

This shows there is less than 1.6 mm (1/16 inches) of tread left on the tire. Replace the tire when this happens.

Do not wait for the band to appear across the entire tread before replacing the tire.

The Anti-lock Brake System (ABS) works by comparing the speed of the wheels. The tire size affects wheel speed. When replacing tires, all 4 tires must use the same size originally supplied with the vehicle. Using tires of a different size can cause the ABS and ESC to malfunction.

It is best to replace all four tires at the same time. If that is not possible, or necessary, then replace the two front or two rear tires as a pair. Replacing just one tire can seriously affect your vehicle's handling.

*** NOTICE**

When replacing tires, use the same originally supplied with the vehicles. If not, that affects driving performance.

Compact spare tire replacement

A compact spare tire has a shorter tread life than a regular size tire.

Replace it when you can see the tread wear indicator bars on the tire. The replacement compact spare tire should be the same size and design tire as the one provided with your new vehicle and should be mounted on the same compact spare tire wheel. The compact spare tire is not designed to be mounted on a regular size wheel, and the compact spare tire wheel is not designed for mounting a regular size tire.

Wheel replacement

When replacing the metal wheels for any reason, make sure the new wheels are equivalent to the original factory units in diameter, rim width and offset.

A wheel with an incorrect size may adversely affect many things: wheel and bearing life, braking and stopping abilities, handling characteristics, ground clearance, body-to-tire clearance, snow chain clearance, speedometer and odometer calibration, headlight aiming and bumper height.

⚠ CAUTION

Wheels

Wheels that do not meet Kia specifications may fit poorly and result in damage to the vehicle or unusual handling and poor vehicle control.

Tire traction

Tire traction can be reduced if you drive on worn tires, tires that are improperly inflated or on slippery road surfaces.

Tires should be replaced when tread wear indicators appear. Slow down whenever there is rain, snow or ice on

the road to reduce the possibility of losing control of the vehicle.

Tire maintenance

In addition to proper inflation, correct wheel alignment helps to decrease tire wear.

If you find a tire is worn unevenly, have your dealer check the wheel alignment.

Make sure the newly installed tires are balanced correctly to increase vehicle ride comfort and tire life. Always rebalance the tire when the tire is removed from the wheel.

Tire sidewall labeling

This information identifies and describes the fundamental characteristics of the tire and provides the Tire Identification Number (TIN) for safety standard certification.

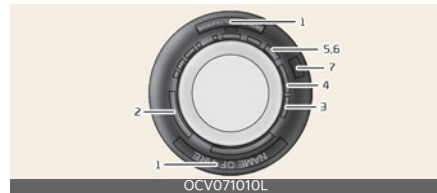

The TIN can be used to identify the tire in case of a recall.

1. Manufacturer or brand name

Manufacturer or Brand name is shown.

2. Tire size designation

A tire's sidewall is marked with a tire size designation. You will need this information when selecting replacement tires for your vehicle. The following explains what the letters and numbers in the tire size designation mean.

Example tire size designation:

(These numbers are provided as an example only; your tire size designator could vary depending on your vehicle.)

P235/45R18 108T

- P: Applicable vehicle type (tires marked with the prefix "P" are intended for use on passenger vehicles or light trucks; however, not all tires have this marking).
- 235: Tire width in millimeters.
- 45: Aspect ratio. The tire's section height as a percentage of its width.
- R: Tire construction code (Radial).
- 18: Rim diameter in inches.
- 108: Load Index, a numerical code associated with the maximum load the tire can carry.
- T: Speed Rating Symbol. See the speed rating chart in this section for additional information.

Wheel size designation

Wheels are also marked with important information that you need if you ever must replace one. The following explains what the letters and numbers in the wheel size designation mean.

Example wheel size designation:

7.5JX18

- 7.5: Rim width in inches.
- J: Rim contour designation.
- 18: Rim diameter in inches.

Tire speed ratings

The chart below lists many of the different speed ratings currently being used for passenger vehicle tires. The speed rating is part of the tire size designation on the sidewall of the tire. This symbol corresponds to that tire's designed maximum safe operating speed.

Speed Rating Symbol	Maximum Speed
S	180 km/h (112 mph)
T	190 km/h (118 mph)
H	210 km/h (130 mph)
V	240 km/h (149 mph)
W	270 km/h (168 mph)
Y	300 km/h (186 mph)

3. Checking tire life

Any tires that are over 6 years old, based on the manufacturing date, should be replaced by new ones. You can find the manufacturing date on the tire sidewall (possibly on the inside of the wheel), displaying the DOT code. The DOT code is a series of numbers on a tire consisting of numbers and English letters. The manufacturing date is designated by the last four digits (characters) of the DOT code.

DOT: XXXX XXXX 0000

The front part of the DOT means a plant code number, tire size and tread pattern and the last four numbers indicate week and year manufactured.

For example:

DOT XXXX XXXX 1624 represents that the tire was produced in the 16th week of 2024.

⚠ WARNING

Tire age

Replace tires within the recommended time frame. Failure to replace tires as recommended can result in sudden tire failure, which could lead to a loss of control and an accident.

4. Tire ply composition and material

The number of layers or plies of rubber-coated fabric in the tire. Tire manufacturers also must indicate the materials in the tire, which include steel, nylon, polyester, and others. The letter "R" means radial ply construction; the letter "D" means diagonal or bias ply construction; and the letter "B" means belted-bias ply construction.

5. Maximum Inflation Pressure

This number is the greatest amount of air pressure that should be put in the tire. Do not exceed the maximum permissible inflation pressure. Refer to "Tire and loading information label" on page 5-45 for recommended inflation pressure.

6. Maximum load rating

This number indicates the maximum load in kilograms and pounds that can be carried by the tire. When replacing the tires on the vehicle, always use a tire that has the same load rating as the factory installed tire.

7. Uniform tire quality grading

Quality grades can be found where applicable on the tire sidewall between tread shoulder and maximum section width.

For example:

- Treadwear 200
- Traction AA
- Temperature A

Tires degrade over time, even when they are not being used. Regardless of the remaining tread, we recommend that

tires (including the spare, if equipped) be replaced after six (6) years of normal service. Heat caused by hot climate or frequent high loading conditions can accelerate the aging process.

Tread wear

The tread wear grade is a comparative rating based on the wear rate of the tire when tested under controlled conditions on a specified government test course. For example, a tire graded 150 would wear one-and-a-half times (1½) as well on the government course as a tire graded 100.

The relative performance of tires depends upon the actual conditions of their use. Performance may depart significantly from the norm due to variations in driving habits, service practices and differences in road characteristics and climate.

These grades are molded on the sidewalls of passenger vehicle tires. The tires available as standard or optional equipment on your vehicle may vary with respect to grade.

Traction: AA, A, B and C

The traction grades, from highest to lowest, are AA, A, B and C. Those grades represent the tire's ability to stop on wet pavement as measured under controlled conditions on specified government test surfaces of asphalt and concrete. A tire marked C may have poor traction performance.

The traction grade assigned to this tire is based on straight-ahead braking traction tests, and does not include acceleration, cornering, hydroplaning, or peak traction characteristics.

Temperature: A, B and C

The temperature grades are A (the highest), B and C representing the tire's resistance to the generation of heat and its ability to dissipate heat when tested under controlled conditions on a specified indoor laboratory test wheel.

Sustained high temperature can cause the material of the tire to degenerate and reduce tire life, and excessive temperature can lead to sudden tire failure. Grades B and A represent higher levels of performance on the laboratory test wheel than the minimum required by law.

Tire terminology and definitions

Refer to the following for detailed definitions of the terms that are found in the tire description:

Air Pressure: The amount of air inside the tire pressing outward on the tire. Air pressure is expressed in pounds per square inch (psi) or kilopascal (kPa).

Accessory Weight: The combined weight of optional accessories. Some examples of optional accessories are automatic transmission, power seats, and air conditioning.

Aspect Ratio: The relationship of a tire's height to its width.

Belt: A rubber coated layer of cords that is located between the plies and the tread. Cords may be made from steel or other reinforcing materials.

Bead: The tire bead contains steel wires wrapped by steel cords that hold the tire onto the rim.

Bias Ply Tire: A pneumatic tire in which the plies are laid at alternate angles less than 90 degrees to the centerline of the tread.

Cold Tire Pressure: The amount of air pressure in a tire, measured in pounds per square inch (psi) or kilopascals (kPa) before a tire has built up heat from driving.

Curb Weight: The weight of a motor vehicle with standard and optional equipment (including the maximum capacity of fuel, oil and coolant), but without passengers and cargo.

DOT Markings: The DOT code includes the Tire Identification Number (TIN), an alphanumeric designator which can also identify the tire manufacturer, production plant, brand and date of production.

GVWR: Gross Vehicle Weight Rating

GAWR FRT: Gross Axle Weight Rating for the Front axle.

GAWR RR: Gross Axle Weight Rating for the Rear axle.

Intended Outboard Sidewall: The side of an asymmetrical tire that must always face outward when mounted on a vehicle.

Kilopascal (kPa): The metric unit for air pressure.

Light truck (LT) tire: A tire designated by its manufacturer as primarily intended for use on lightweight trucks or multipurpose passenger vehicles.

Load ratings: The maximum load that a tire is rated to carry for a given inflation pressure.

Load Index: An assigned number ranging from 1 to 279 that corresponds to the load carrying capacity of a tire.

Maximum Inflation Pressure: The maximum air pressure to which a cold tire may be inflated. The maximum air pressure is molded onto the sidewall.

Maximum Load Rating: The load rating for a tire at the maximum permissible inflation pressure for that tire.

Maximum Loaded Vehicle Weight: The sum of curb weight; accessory weight; vehicle capacity weight; and production options weight.

Normal Occupant Weight: The number of occupants a vehicle is designed to seat multiplied by 68 kg (150 lbs.).

Occupant Distribution: Designated seating positions.

Outward Facing Sidewall: The side of an asymmetrical tire that has a particular side that faces outward when mounted on a vehicle. The outward facing sidewall bears white lettering or bears manufacturer, brand, and/or model name molding that is higher or deeper than the same moldings on the inner facing sidewall.

Passenger (P-Metric) Tire: A tire used on passenger cars and some light duty trucks and multipurpose vehicles.

Ply: A layer of rubber-coated parallel cords.

Pneumatic tire: A mechanical device made of rubber, chemicals, fabric and steel or other materials, that, when mounted on an automotive wheel, provides the traction and contains the gas or fluid that sustains the load.

Production options weight: The combined weight of installed regular production options weighing over 2.3 kg (5 lbs.) in excess of the standard items which they replace, not previously considered in curb weight or accessory weight. Examples include heavy-duty brakes, ride levelers, roof rack, heavy-duty battery, and special trim.

Recommended Inflation Pressure: Vehicle manufacturer's recommended

tire inflation pressure and shown on the tire placard.

Radial Ply Tire: A pneumatic tire in which the ply cords that extend to the beads are laid at 90 degrees to the centerline of the tread.

Rim: A metal support for a tire and upon which the tire beads are seated.

Sidewall: The portion of a tire between the tread and the bead.

Speed Rating: An alphanumeric code assigned to a tire indicating the maximum speed at which a tire can operate.

Traction: The friction between the tire and the road surface. The amount of grip provided.

Tread: The portion of a tire that comes into contact with the road.

Treadwear Indicators: Narrow bands, sometimes called "wear bars," that show across the tread of a tire when only 1.6 mm (2/32 inch) of tread remains.

UTQGS: Uniform Tire Quality Grading Standards, a tire information system that provides consumers with ratings for a tire's traction, temperature and treadwear. Ratings are determined by tire manufacturers using government testing procedures. The ratings are molded into the sidewall of the tire.

Vehicle Capacity Weight: The weight of designated seating positions multiplied by 68 kg (150 lbs.) plus the rated cargo and luggage load.

Vehicle Maximum Load on the Tire: Load on an individual tire due to curb and accessory weight plus maximum occupant and cargo weight.

Vehicle Normal Load on the Tire: Load on an individual tire that is determined by distributing to each axle its share of the curb weight, accessory weight, and

normal occupant weight and driving by 2.

Vehicle Placard: A label permanently attached to a vehicle showing the original equipment tire size and recommended inflation pressure.

All-season tires

Kia specifies all-season tires on some models to provide good performance for use all year round, including snowy and icy road conditions.

All-season tires are identified by ALL SEASON and/or M+S (Mud and Snow) on the tire sidewall. Snow tires have better snow traction than all-season tires and may be more appropriate in some areas.

Summer tires

Kia specifies summer tires on some models to provide superior performance on dry roads.

Summer tire performance is substantially reduced in snow and ice. Summer tires do not have the tire traction rating M+S (Mud and Snow) on the tire sidewall. If you plan to operate your vehicle in snowy or icy conditions, Kia recommends the use of snow tires or all-season tires on all four wheels.

Snow tires

If you equip your vehicle with snow tires, they should be the same size and have the same load capacity as the original tires.

Snow tires should be installed on all four wheels; otherwise, poor handling may result.

Snow tires should carry 28 kPa (4 psi) more air pressure than the pressure recommended for the standard tires on the tire label on the driver's side of the cen-

ter pillar, or up to the maximum pressure shown on the tire sidewall, whichever is less.

Do not drive faster than 120 km/h (75 mph) when your vehicle is equipped with snow tires.

WARNING

Do not use summer tires at temperatures below 7 °C (45 °F) or when driving on snow or ice. At temperatures below 7 °C (45 °F), summer tires can lose elasticity, and therefore traction and braking power as well. Change the tires on your vehicle to winter or all-weather tires of the same size as the standard tires of the vehicle. Both types of tires are identified by the M+S (Mud and Snow) marking. Using summer tires at very cold temperatures could cause cracks to form, thereby damaging the tires permanently.

Radial-ply tires

Radial-ply tires provide improved tread life, road hazard resistance and smoother high-speed ride.

The radial-ply tires used on this vehicle are of belted construction and are selected to complement the ride and handling characteristics of your vehicle. Radial-ply tires have the same load carrying capacity, as bias-ply or bias belted tires of the same size, and use the same recommended inflation pressure.

Mixing of radial-ply tires with bias-ply or bias belted tires is not recommended. Any combinations of radial-ply and bias-ply or bias belted tires when used on the same vehicle will seriously deteriorate vehicle handling. The best rule to follow is for all four identical radial-ply tires to always be used.

Longer wearing tires can be more susceptible to irregular tread wear. It is very important to follow the tire rotation interval shown in this section to achieve the best tread. Cuts and punctures in radial-ply tires are repairable only in the tread area, because of sidewall flexing. Consult your tire dealer for radial-ply tire repairs.

Low aspect ratio tire (if equipped)

Low aspect ratio tires, whose aspect ratio is lower than 50, are provided for sporty looks.

Because the low aspect ratio tires are optimized for handling and braking, it may be more uncomfortable to ride in and there is more noise compare with normal tires.

CAUTION

Because the sidewall of the low aspect ratio tire is shorter than normal, the wheel and tire of the low aspect ratio tire is more easily damaged. So, follow the instructions below.

- When driving on a rough road or off-road, drive cautiously because tires and wheels may be damaged. And after driving, inspect tires and wheels.
- When passing over a pothole, speed bump, manhole, or curb stone, drive slowly so that the tires and wheels are not damaged.
- If the tire is impacted, we recommend that you inspect the tire condition or contact an authorized Kia dealer.
- To prevent damage to the tire, inspect the tire condition and pressure every 3,000 km (1,900 miles).

there is the slightest hint of tire damage, even though you cannot see the tire damage with your own eyes, have the tire checked or replaced because the tire damage may cause air leakage from the tire.

- If the tire is damaged by driving on a rough road, off-road, pothole, manhole, or curb stone, it will not be covered by the warranty.
- You can find out the tire information on the tire sidewall.

-
- It is not easy to recognize the tire damage with your own eyes. But if

Fuses

A vehicle's electrical system is protected from electrical overload damage by fuses.

Blade type



Cartridge type



Multi fuse

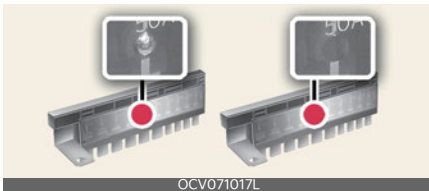

BFT

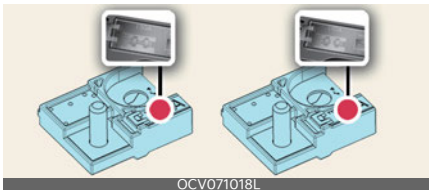

* Left side: Normal, Right side: Blown
This vehicle has 2 (or 3) fuse panels, one located in the driver's side panel bolster, the other in the engine compartment near the battery.

If any of your vehicle's lights, accessories, or controls do not work, check the

appropriate circuit fuse. If a fuse has blown, the element inside the fuse will melt.

If the electrical system does not work, first check the driver's side fuse panel.

If the replacement fuse blows, this indicates an electrical problem. Avoid using the system involved and immediately consult an authorized Kia dealer.

Three kinds of fuses are used: blade type for lower amperage rating, cartridge type, and multi fuse for higher amperage ratings.

⚠ WARNING

Fuse replacement

- Never replace a fuse with anything other than a fuse of the same rating.
- A higher capacity fuse could cause damage and possibly a fire.
- Never install a wire or aluminum foil instead of the proper fuse - even as a temporary repair. It may cause extensive wiring damage and a possible fire.
- Do not arbitrarily modify or add electric wiring to the vehicle.

⚠ CAUTION

Do not use a screwdriver or any other metal object to remove fuses because it may cause a short circuit and damage the system.

* NOTICE

- When replacing a fuse, turn the ignition 'OFF' and turn off switches of all electrical devices then remove battery (-) terminal.
- The actual fuse/relay panel label may differ from equipped items.

⚠ WARNING

Electrical Fire

Always ensure replacements fuses and relays are securely fastened when installed. Failure to do so can result in a vehicle fire.

Do not remove fuses, relays and terminals fastened with bolts or nuts. The fuses, relays and terminals may be fastened incompletely, and it may cause a possible fire. If fuses, relays and terminals fastened with bolts or nuts are blown, consult with an authorized Kia dealer.

⚠ CAUTION

When replacing a blown fuse or relay, ensure the new fuse or relay fits tightly into the clips. Failure to tightly install the fuse or relay may cause damage to the wiring and electric systems.

⚠ CAUTION

- Do not put objects except fuses or relays into fuse/relay terminals such as a screwdriver or wiring. It may cause contact failure and system malfunction.
- Do not plug in screwdrivers or after-market wiring into the terminal originally designed for fuse and relays only. The electrical system and wiring of the vehicle interior may be damaged or burned due to contact failure.
- If you directly connect the wire on the taillight or replace the bulb which is over the regulated capacity to install trailers etc., the inner junction block can get burned.

⚠ WARNING

Electrical wiring repairs

All electrical repairs should be performed by authorized Kia dealerships using approved Kia parts. Using other wiring components, especially when retrofitting multimedia or a theft alarm system, car phone or radio may cause vehicle damage and increase the risk of a vehicle fire.

*** NOTICE**

Rewiring Prohibited

Do not rewire your vehicle in any way as doing so may affect the performance of several safety features in your vehicle. Rewiring your vehicle may also void your warranty and you may be responsible for any subsequent vehicle damage which may result.

Replacing inner panel fuse

1. Turn the ENGINE START/STOP button and all other switches off.
2. Open the fuse panel cover.



3. Pull the suspected fuse straight out. Use the removal tool provided on the engine fuse panel cover.



4. Check the removed fuse; replace it if it is blown.

Spare fuses are provided in the engine compartment fuse panel.

5. Push in a new fuse of the same rating, and make sure it fits tightly in the clips.

If it fits loosely, consult an authorized Kia dealer.

If you do not have a spare, use a fuse of the same rating from a circuit you may not need for operating the vehicle, such as the power outlet fuse.

If the head lamp, turn signal lamp, stop signal lamp, fog lamp, DRL, tail lamp, High Mounted Stop Lamp (HMSL) do not work and the fuses are OK, check the fuse panel in the engine compartment. If a fuse is blown, it must be replaced.

* NOTICE

If the headlamp, fog lamp, turn signal lamp, or tail lamp malfunction even without any problem to the lamps, have the vehicle checked by an authorized Kia dealer for assistance.

Replacing engine compartment fuse

1. Turn the ENGINE START/STOP button and all other switches off.
2. Remove the fuse panel cover by pressing the tab and pulling the cover up.



3. Check the removed fuse; replace it if it is blown. To remove or insert the

fuse, use the fuse puller in the engine compartment fuse panel.

4. Push in a new fuse of the same rating and make sure it fits tightly in the clips. If it fits loosely, consult an authorized Kia dealer.

⚠ CAUTION

Always securely install the fuse panel cover in the engine compartment to protect against electrical failure which may occur from water contact. Listen for the audible clicking sound to ensure fuse panel cover is securely fastened.

* NOTICE

If the main (multi) fuse is blown, have the vehicle checked by an authorized Kia dealer.

* NOTICE

The electronic system may not function correctly even when the engine compartment and internal fuse box's individual fuses are not disconnected. In such cases, the cause of the problem may be disconnection of the main fuse (BFT type), which is located inside the positive battery terminal (+) cap. Since the main fuse is designed more intricately than other parts, have the vehicle checked by an authorized Kia dealer.

After checking the fuse panel in the engine compartment, securely install the fuse panel cover. Electrical failures may occur from water contact.

Main fuse (Multi fuse)

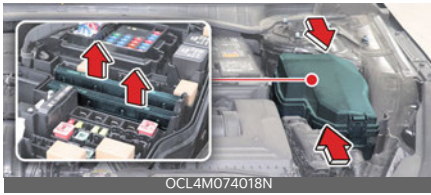

If the multi fuse is blown, it must be removed as follows:

1. Turn the ENGINE START/STOP button and all other switches off.
2. Disconnect the negative battery cable.
3. Remove the nuts shown in the picture above.
4. Replace the fuse with a new one of the same rating.
5. Reverse these steps to reinstall the multi fuse.

* NOTICE

Do not modify the multi fuse when it is secured with nuts and bolts. Incorrect or partial assembly torque may cause a fire. Have the vehicle checked by an authorized Kia dealer.

Battery fuse

If the battery fuse is blown, it must be removed as follows:

1. Disconnect the negative battery cable.
2. Remove the nuts shown in the picture below.



3. Replace the fuse with a new one of the same rating.

4. Reinstall in the reverse order of removal.

* NOTICE

If the battery fuse is blown, have the vehicle checked by an authorized Kia dealer.

⚠ CAUTION

Visually inspect the battery cap to ensure it is securely closed. If the battery cap is not securely closed, moisture may enter the system and damage the electrical components.

Fuse/relay panel description

Inside the fuse/relay panel covers, you can find the fuse/relay label describing fuse/relay name and capacity.

Driver's side fuse panel

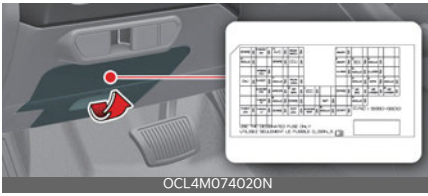

* NOTICE

Not all fuse panel descriptions in this manual may apply to your vehicle. They are accurate at the time of printing. When you inspect the fuse panel in your vehicle, refer to the fuse panel label on the inside of the fuse cover. This diagram will provide you with the specific information for your vehicles.

SPARE	15A	P/WINDOW DRV	10A	2 AC	7.5A	BRAKE SWITCH	7.5A	1 MEMORY	10A								
B MODULE	10A			SPARE	10A	CCU	10A	2 MEMORY	7.5A	2 EDC	7.5A	2 MODULE	10A				
		W/LESS DCU	7.5A					MULTIMEDIA	5A	5 MODULE	10A	2 CLUSTER	7.5A				
CVU	15A	SUNROOF	7.5A	7 MODULE	7.5A	TRUNK OPEN	10A			3 MODULE	10A	2 MCP5	7.5A	1 MODULE	10A		
		S/HEATER FRT	7.5A	2 W/ASER	15A	2 AIR BAG	10A	1 EDC	10A			SPARE	7.5A	1 AIR BAG	10A	1 USB CHARGER	7.5A
		P/WINDOW RH	7.5A	6 MODULE	7.5A	SPARE	10A			AMP	7.5A			4 MODULE	10A	2 USB CHARGER	10A
P/SEAT DRV	10A	P/WINDOW LH	7.5A	SPARE	10A	DOOR LOCK	10A	S/HEATER REAR	7.5A	9 MODULE	10A	START	7.5A	P/N/O : 91990-GG010			

USE THE DESIGNATED FUSE ONLY
UTILISEZ SEULEMENT LE FUSIBLE D_SIGN_S

OCL4M074021N

Refer to the following table for a description of the fuse.

PDC Junction Block

Fuse Name	Fuse rating	Circuit Protected
A/C2	7.5A	DATC (Dual Auto Temperature Control)/MTC (Manual Temperature Control), Engine Room Junction Block PTC (Positive Temperature Coefficient Heater) Heater Relay 1-2, Air con - Comp (Smartstream G1.6 T-GDi)
AIR BAG1	10A	ACU (Airbag Control Unit), AIR BAG, ODS (Occupant (Central Communication Unit) Detection System)
AIR BAG2	10A	ACU (Airbag Control Unit), AIR BAG
AMP	25A	AMP (Amplifier), LDC (Low voltage DC-DC Converter) 450
BDC1	10A	BDC (Body Domain Controller), Bluetooth Unit, UWB (Ultra Wide Band) Unit, ATM LEVER(AT/CVT/DCT)
BDC2	7.5A	BDC (Body Domain Controller), BMS (Battery Management System)
BRAKE SWITCH	7.5A	BDC (Body Domain Controller), Stop Lamp Switch
CCU	10A	CCU (Central Communication Unit)
CLUSTER	7.5A	Cluster, HUD (Head Up Display)
DOOR LOCK	20A	Door Lock Relay, Door Unlock Relay, Two Turn Unlock/Dead lock Relay
MDPS2	7.5A	MDPS (Motor Driven Power Steering)
MEMORY1	10A	Cluster, MTC ((Manual Temperature Control)), DATC (Dual Auto Temperature Control), Mood Lamp, PDW Sensor
MEMORY2	7.5A	FRT USB Jack, Wireless Charging
MODULE1	10A	BDC (Body Domain Controller), DCU (Domain Control Unit), CCU (Central Communication Unit), VDMS, AVN Keyboard, Overhead Console E-CALL, ADAS (Advanced Driver Assistance System) PRK ECU (electronic Control Unit), AMP (Amplifier), CCNC (Connected Car Navigation & Cockpit), LDC (Low voltage DC-DC Converter), Engine Room Junction Block Power Outlet Relay
MODULE2	10A	CCU (Central Communication Unit), DCU (Domain Control Unit)(E-CALL)
MODULE3	10A	Power Window Switch (DRV)
MODULE4	10A	LKAS (Lane Keeping Assist System) Camera, ADAS (Advanced Driver Assistance System) DRV, Console Upper, ADAS (Advanced Driver Assistance System) Parking ECU (electronic Control Unit)
MODULE5	10A	ICC (In Cabin Camera) Unit, CCNC (Connected Car Navigation & Cockpit), MUT/VDMS Overhead Console PAB, I/S MIRROR ECM, DATC (Dual Auto Temperature Control)/MTC (Manual Temperature Control) PANEL, Console Upper, CDU, Wireless Charging, LDC (Low voltage DC-DC Converter) 200/450, AMP (Amplifier), SEAT(IMS), Front Door Switch, Head Lamp LH/ RH, C/PAD Switch
MODULE6	7.5A	BDC (Body Domain Controller)
MODULE7	7.5A	P-LBM (Parking Lithium Battery Module), W/S Heated Glass LH/RH Coil
MODULE8	10A	Smart Key Interlock, Rain Sensor, Hazard, MUT/PTG_A(WAG), ICC (In Cabin Camera) Unit
MODULE9	10A	Power Window Switch (DRV), IMS ECU (Electronic Control Unit), Digital Key
MULTIMEDIA	25A	CCNC (Connected Car Navigation & Cockpit), LDC (Low voltage DC-DC Converter)_200
OMU	15A	Out Side Mirror Motor DRV/PASS
P/SEAT DRV	30A	Power Seat (DRV)

Fuse Name	Fuse rating	Circuit Protected
P/WINDOW DRV	15A	Power Window DRV Up/Down Relay
P/WINDOW LH	25A	Safety ECU (Electronic Control Unit) DRV/PASS/RL, Power Window Switch RL/PASS
P/WINDOW RH	25A	Safety ECU (Electronic Control Unit) DRV/PASS/RR, Power Window Switch RR/PASS
S/HEATER FRT	25A	Seat Heater/Vent (FRT)
S/HEATER RR	25A	Seat Heater (RR)
SPARE	10A	SPARE
SPARE	15A	SPARE
SPARE	10A	SPARE
SPARE	10A	SPARE
SPARE	7.5A	SPARE
START	7.5A	Start Inhibit Relay, Inhibit Switch, IGN Switch
SUNROOF	20A	SUNROOF
TRUNK OPEN	10A	Trunk Open Relay
USB CHARGER1	15A	Rear USB Charger, Start/Stop Button
USB CHARGER2	10A	USB Charger
WASHER	15A	WASHER
wireless DCU	7.5A	DCU (Domain Control Unit)

* MDPS (Motor Driven Power Steering) is the same as EPS (Electric Power Steering).

Engine compartment fuse panel

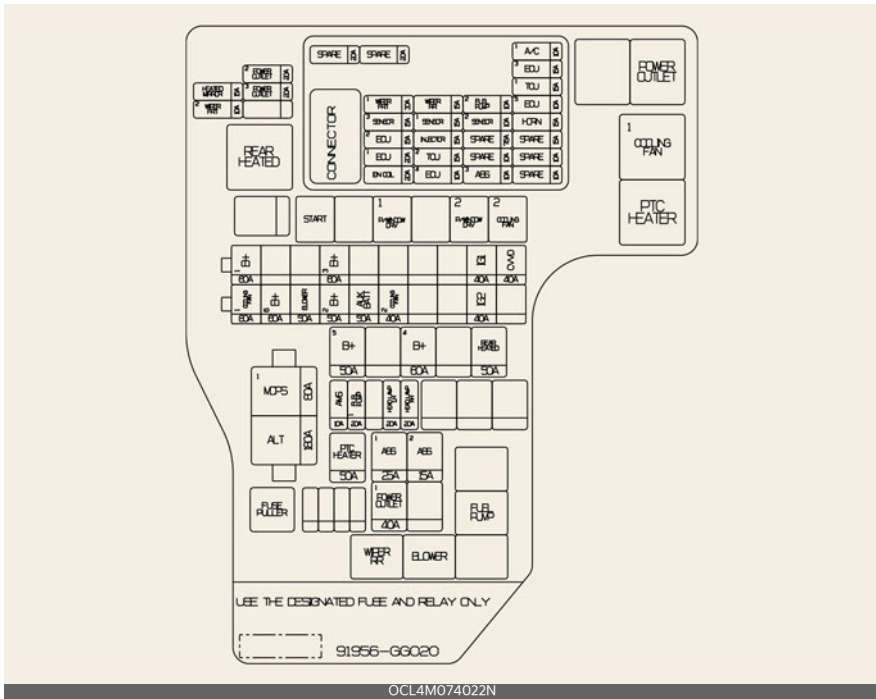

Refer to the following table for a description of the fuse.

Engine Room Junction Block

Fuse Name	Fuse rating	Circuit Protected
A/C1	10A	A/C Relay
ABS1	25A	ESC (Electronic Stability Control) Unit, ABS (Anti-lock Brake System) Unit, EPB (Electronic Parking Brake) Unit
ABS2	15A	ESC (Electronic Stability Control) Unit, ABS (Anti-lock Brake System) Unit, EPB (Electronic Parking Brake) Unit
ABS3	10A	ESC (Electronic Stability Control) Unit, ABS (Anti-lock Brake System) Unit, EPB (Electronic Parking Brake) Unit

Fuse Name	Fuse rating	Circuit Protected
ALT	180A	Alternator Output, MHSG (Mild Hybrid Starter and Generator) Output, BATT +
AMS	10A	Battery Sensor
AUX BATT	50A	P-LBM (Lithium Battery)
B+1	60A	PDC (IPS1, IPS2, IPS3, IPS4, IPS5, IPS6, IPS7)
B+2	50A	PDC (IPS8, IPS9, IPS10, IPS11, IPS12)
B+3	60A	PDC (Fuse - SPARE, P/SEAT DRV, S/HEATER FRT, P/WINDOW(LH/RH/DRV), OMU, SUNROOF, wireless DCU, MODULE8
B+4	60A	PDC (Relay - Long Term Load Latch Relay, DOOR LOCK/UNLOCK Relay, Two Turn Unlock/Dead Lock Relay, Trunk/Tailgate Open Relay, Fuse - MULTIMEDIA, MEMORY1, MEMORY2, BDC1, BREAK SWITCH, CCU, S/HEATER RR, DOOR LOCK, Trunk Open, Tailgate Open)
B+5	50A	PDC (Fuse - AMP, AIR BAG2, BMS, MODULE9, BATTERY C/FAN, A/C3, USB CHARGER2
B+6	60A	Engine Room Junction Block PCB Block
BLOWER	50A	Blower Motor Relay
COOLING FAN1	80A	Cooling Fan BLDC (Brushless Direct Current Motor)
COOLING FAN2	40A	Cooling Fan 1, 2 Relay
CVVD	40A	CVVD (Continuous Variable Valve Duration) Actuator
ECU1	20A	ECM (Engine Control Module)
ECU2	15A	ECM (Engine Control Module)
ECU3	15A	ECM (Engine Control Module)
ECU4	10A	ECM (Engine Control Module)
ECU5	10A	ECM (Engine Control Module)
FUEL PUMP1	20A	Fuel Pump Relay
FUEL PUMP2	10A	Fuel Pump Relay
HEAD LAMP LH	20A	HEAD LAMP LH
HEAD LAMP RH	20A	HEAD LAMP RH
HEATED MIRROR	15A	ECU (Electronic Control Unit), Driver/Passenger Power Outside Mirror
HORN	15A	HORN Relay
IG1	40A	IG1 Relay, ACC Relay, IGN SW
IG2	40A	IGN SW, IG2 Relay, Start Relay
IGN COIL	20A	Ignition Coil
INJECTOR	15A	Injector, MHSG (Mild Hybrid Starter and Generator) Signal
MDPS1	80A	MDPS (Motor Driven Power Steering) Unit
POWER OUTLET1	40A	Engine Room Junction Block Power Outlet Relay
POWER OUTLET2	20A	Power Outlet FRT
POWER OUTLET3	20A	Power Outlet Luggage
PTC HEATER	50A	PTC (Positive Temperature Coefficient) Heater Relay
REAR HEATED	50A	Rear Heated Relay

Fuse Name	Fuse rating	Circuit Protected
SENSOR1	15A	O2 Sensor
SENSOR2	10A	OCV (Oil Control Valve), Oil Level Sensor, PCSV (Purge Control Solenoid Valve), VIS (Variable Induction System)/VOP (Variable Oil Pump), RCV (Recirculation Control Valve)/OPSV, CCV (Canister Close Valve)
SENSOR3	15A	Cooling Fan BLDC (Brushless Direct Current Motor), Cooling Fan High Relay, Cooling Fan Low Relay
SPARE	15A	SPARE
SPARE	20A	SPARE
SPARE	20A	SPARE
SPARE	7.5A	SPARE
SPARE	10A	SPARE
SPARE	10A	SPARE
SPARE	10A	SPARE
TCU1	15A	TA8 8AT(Automatic Transmission), TCU (Transmission Control Unit), 6AT TCU, CVT (Continuously Variable Transmission) TCU, 7DCT(Dual Clutch Transmission) TCU
TCU2	15A	7DCT(Dual Clutch Transmission) TCU (Transmission Control Unit), 8AT(Automatic Transmission) TCU
WIPER FRT1	30A	Wiper Motor, Wiper FRT Low Relay
WIPER FRT2	10A	BDC
WIPER RR	15A	Rear Wiper

* 1: MDPS (Motor Driven Power Steering) is the same as EPS (Electric Power Steering).

Relay Name	Type
Blower Relay	MICRO
Cooling Fan1 Relay	MINI
Cooling Fan2 Relay	MICRO
Fuel Pump Relay	MINI
Power Window DRV1 Relay	MICRO
Power Window DRV2 Relay	MICRO
Power Outlet Relay	MINI
PTC Heater Relay	MICRO
Rear Heated Relay	MINI
Start Relay	MICRO
Wiper RR Relay	MICRO

Light bulbs

Light bulbs are installed in various parts of the vehicle to provide lighting inside and outside the vehicle and to alert other vehicles.

Bulb replacement precaution

Please keep extra bulbs on hand with appropriate wattage ratings in case of emergencies.

Refer to "Bulb wattage" on page 9-7.

When changing lamps, first turn off the vehicle at a safe place, firmly apply the parking brake and detach the battery's negative (-) terminal.

⚠ WARNING

Working on the lights

Prior to working on the light,

- (1) Firmly apply the parking brake
- (2) Turn the ENGINE START/STOP button to the OFF position
- (3) Turn off the lights to avoid sudden movement of the vehicle and burning your fingers or receiving an electric shock.

Use only bulbs of the specified wattage.

⚠ CAUTION

Light bulb replacement

Be sure to replace the burned-out bulb with one of the same wattage rating. It may cause damage to the fuse or electric wiring system.

Fully install light bulbs and any parts used to secure them. Failure to do so may result in heat damage, fire, or water entering the headlight unit. This may damage the headlights or cause condensation to build up on the lens. To

prevent damage or fire, make sure bulbs are fully seated and locked.

⚠ CAUTION

Headlamp Lens

To prevent damage, do not clean the headlamp lens with chemical solvents or strong detergents.

* NOTICE

- If the light bulb or lamp connector is removed while the lamp is still on, the fuse box's electronic system may log it as a malfunction. Therefore, a lamp malfunction incident may be recorded as a Diagnostic Trouble Code (DTC) in the fuse box.
- It is normal for an operating lamp to flicker momentarily. This is due to a stabilization function of the vehicle's electronic control device. If the lamp lights up normally after momentarily blinking, then it is functioning as normal.

However, if the lamp continues to flicker several times or turns off completely, there may be an error in the vehicle's electronic control device. Please have the vehicle checked by an authorized Kia dealer immediately.

* NOTICE

Have the headlight aiming adjusted by an authorized Kia dealer after an accident or after the headlight assembly is reinstalled.

* NOTICE

You can find moisture inside the lens of lamps after a car wash or driving in the rain. It is a natural event caused by the

temperature difference between the inside and the outside of the lamp and does not mean there is a problem with its functions. The moisture inside the lamp would disappear if you drive the vehicle with the headlamp turned on. However, the level at which the moisture is removed may differ depending on the size/location/condition of the lamp. If the moisture continues to stay inside the lamp, have the vehicle checked by an authorized Kia dealer.

If you don't have the necessary tools, the correct bulbs and the expertise, consult an authorized Kia dealer. In many cases, it is difficult to replace vehicle light bulbs because other parts of the vehicle must be removed before you can access the bulb. This is especially true if you have to remove the headlamp assembly to get to the bulb(s).

Removing/installing the headlamp assembly can result in damage to the vehicle. If non-genuine parts or substandard bulbs are used, it may lead to blowing a fuse or other wiring damages. Kia Genuine Parts are guaranteed for quality and performance.

Do not install extra lamps or LEDs in the vehicle. It may lead to lamp malfunctions and flickering. The fuse box and other wiring may be damaged.

Light bulb position (Front)

Headlamp (Type A)



Headlamp (Type B)

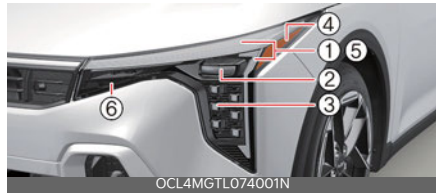

- 1 Day time running lamp/Position lamp/ Turn signal lamp (LED type)
- 2 Headlamp (Low) (LED type)
- 3 Headlamp (High) (LED type)
- 4 Front side marker (LED type)
- 5 Day time running lamp/Position lamp/ Turn signal lamp (LED type)
- 6 Fog lamp (LED type)

Light bulb position (Rear)

Rear combination lamp (Type A)



Rear combination lamp (Type B)



High mounted stop lamp



- 1 Tail lamp (LED type)
- 2 Stop lamp and Turn signal lamp (Bulb type)
- 3 Rear side marker (LED type)
- 4 License plate lamp (LED type)
- 5 Rear Reflector
- 6 Back up lamp (Bulb type)
- 7 High mounted stop lamp (LED type)
- 8 Stop lamp and Turn signal lamp (LED type)

* if equipped

If the high-mounted stop lamp (LED) (1) is not functioning, please have your vehicle inspected by an authorized Kia dealer. The LED lamp cannot be replaced as a single unit because it is an integrated component. Instead, the entire LED lamp unit must be replaced. It's essential to have a skilled technician check or repair the high-mounted stop lamp (LED) to prevent any damage to related vehicle parts.

Light bulb position (Side)



- 1 Side repeater lamp (LED type)

Replacing lights (LED type)

If the LED lamp is not functioning, please have your vehicle inspected by an authorized Kia dealer. The LED lamp cannot be replaced as an individual component since it is an integrated unit. Instead, the entire LED lamp unit must be replaced.

A skilled technician should check or repair the LED lamp, for it may damage related parts of the vehicle.

Replacing high mounted stop lamp bulb (LED type)



Replacing turn signal lamp and stop lamp (Rear combination lamp) (Type A) (if equipped)



- 1 Stop lamp
- 2 Turn signal lamp

To replace the bulb:

1. Engage the parking brake, shift to P and turn the ignition OFF.
2. Turn of the rear combination lamp.
3. Open the trunk.
4. Remove the rear combination lamp assembly from the body of vehicle using the flat-blade screwdriver.
5. Remove the socket from the assembly by pressing it in and rotating it counterclockwise
6. Pull the bulb out of the socket.
7. Insert a new bulb into socket.
8. Push the socket into the assembly and turn the socket clockwise.
9. Reinstall the assembly to the body of the vehicle.

Appearance care

Use the information in the following sections to keep the exterior and interior of your vehicle clean.

Exterior care

Use the information in the following sections to maintain the exterior of your vehicle. Keeping the exterior clean is not only aesthetically pleasing, but also helps to prolong the life of your vehicle.

* NOTICE

If you park the vehicle around a stainless signboard or windshield building etc., the plastic exterior trim (bumper, spoiler, garnish, lamp, outside mirror etc.) may be damaged by reflected sunlight from the external structure. To avoid damaging the plastic exterior trim, park the vehicle away from areas where the reflected light may occur or use a vehicle cover. (Depending on the vehicle, the type of exterior trim applied such as the spoiler, may differ.)

Exterior general caution

It is very important to follow the label directions when using any chemical cleaner or polish. Read all warning and caution statements that appear on the label.

Finish maintenance

Washing

To help protect your vehicle's finish from rust and deterioration, wash it thoroughly and frequently at least once a month with lukewarm or cold water.

If using your vehicle for off-road driving, you should wash it after each off-road

trip. Pay special attention to the removal of any accumulation of salt, dirt, mud, and other foreign materials. Make sure the drain holes in the lower edges of the doors and rocker panels are kept clear and clean.

Insects, tar, tree sap, bird droppings, industrial pollution and similar deposits can damage your vehicle's finish if not removed immediately.

Even prompt washing with plain water may not completely remove all these deposits. A mild soap, safe for use on painted surfaces, may be used.

After washing, rinse the vehicle thoroughly with lukewarm or cold water. Do not allow soap to dry on the finish.

After washing the vehicle, test the brakes while driving slowly to see if they have been affected by water. If braking performance is impaired, dry the brakes by applying them lightly while maintaining a slow forward speed.

CAUTION

- Do not use strong soap, chemical detergents or hot water, and do not wash the vehicle in direct sunlight or when the body of the vehicle is warm.
- Be careful when washing the side windows of your vehicle, especially with high-pressure water. Water may leak through the windows and wet the interior.
- To prevent damage to the plastic parts and lights, do not clean with chemical solvents or strong detergents.

WARNING

After washing the vehicle, test the brakes while driving slowly to see if they have been affected by water. If braking

performance is impaired, dry the brakes by applying them lightly while maintaining a slow forward speed.

High-pressure washing

When using high-pressure washers, make sure to maintain sufficient distance from the vehicle.

Insufficient clearance or excessive pressure can lead to component damage or water penetration.

Do not spray the camera, sensors or its surrounding area directly with a high-pressure washer. Shock applied from high pressure water may cause the device to not operate normally.

Do not bring the nozzle tip close to boots (rubber or plastic covers) or connectors as they may be damaged if they contact high pressure water.

WARNING

After washing the vehicle, test the brakes while driving slowly to see if they have been affected by water. If braking performance is impaired, dry the brakes by applying them lightly while maintaining a slow forward speed.

⚠ CAUTION**Wetting engine compartment**

- Water washing in the engine compartment including high pressure washing may cause the failure of electrical circuits located in the engine compartment.
- Never allow water or other liquids to contact electrical/electronic components and air ducts inside the vehicle as this may damage them.
- After the vehicle has been washed, brake carefully while paying attention to the traffic conditions until the braking effect has been fully restored.

Waxing

Wax the vehicle when water will no longer bead on the paint.

Always wash and dry the vehicle before waxing. Use a good quality liquid or paste wax and follow the manufacturer's instructions. Wax all metal trim to protect it and to maintain its luster.

Removing oil, tar, and similar materials with a spot remover will usually strip the wax from the finish. Be sure to re-wax these areas even if the rest of the vehicle does not yet need waxing.

Be careful not to touch the lens when waxing the light.

⚠ CAUTION**Drying vehicle**

- Wiping dust or dirt off the body with a dry cloth will scratch the finish.
- Do not use steel wool, abrasive cleaners, acid detergents or strong detergents containing high alkaline or caustic agents on chrome-plated or anodized aluminum parts. This may result in damage to the protective coating and cause discoloration or paint deterioration.

Finish damage repair

Deep scratches or stone chips in the painted surface must be repaired promptly. Exposed metal will quickly rust and may cause a major repair expense.

*** NOTICE**

If your vehicle is damaged and requires any metal repair or replacement, be sure the body shop applies anti-corrosion materials to the parts repaired or replaced.

*** NOTICE****Matte paint finish vehicle**

In case of matte paint finish vehicles, it is impossible to modify only the damaged area and repair of the whole part is necessary. If the vehicle is damaged and painting is required, have your vehicle maintained and repaired by an authorized Kia dealer. Take extreme care, as it is difficult to restore the quality after the repair.

Bright-metal maintenance

To remove road tar and insects, use a tar remover, not a scraper or other sharp object.

To protect the surfaces of bright metal parts from corrosion, apply a coating of wax or chrome preservative and rub to a high luster.

During winter weather or in coastal areas, cover the bright metal parts with a heavier coating of wax or preservative. If necessary, coat the parts with non-corrosive petroleum jelly or other protective compound.

Underbody maintenance

Road salt and other corrosive chemicals are used in cold weather areas to melt snow and prevent ice accumulation. If these chemicals are not regularly removed, they will corrode the vehicle underbody and, over time, damage many parts: the fuel lines, the fuel tank retention system, suspension, exhaust system, and even the body frame.

Aluminum wheel maintenance

The aluminum wheels are coated with a clear protective finish.

- Do not use an abrasive cleaner, polishing compound, solvent, or wire brushes on aluminum wheels. They may scratch or damage the finish.
- Clean the wheel when it has cooled.
- Use only a mild soap or neutral detergent, and rinse thoroughly with water. Also, be sure to clean the wheels after driving on salted roads. This helps prevent corrosion.
- Avoid washing the wheels with high-speed vehicle wash brushes.

- Do not use any alkaline or acid detergents. It may damage and corrode the aluminum wheels coated with a clear protective finish.

Corrosion protection

Protecting your vehicle from corrosion

Using the most advanced design and construction practices to combat corrosion, Kia produces vehicles of the highest quality. This is only part of the job. To achieve the long-term corrosion resistance your vehicle can deliver, your cooperation and assistance is also required.

Common causes of corrosion

The most common causes of corrosion on your vehicle are:

- Road salt, dirt and moisture that is allowed to accumulate underneath the vehicle.
- Removal of paint or protective coatings from stones, gravel, abrasions or minor scrapes and dents can leave unprotected metal exposed to corrosion.

High-corrosion areas

If you live in an area that is regularly exposed to corrosive materials, corrosion protection is particularly important. Some common causes of accelerated corrosion are road salts, dust control chemicals, ocean air and industrial pollution.

Moisture breeds corrosion

Moisture creates the conditions where corrosion is most likely to occur. Corro-

sion is accelerated by high humidity, particularly when temperatures are just above freezing. The corrosive material is kept in contact with the vehicle's surface by moisture that evaporates slowly.

Mud is particularly corrosive because it dries slowly and holds moisture in the vehicle. Although the mud appears to be dry, it can still retain moisture and promote corrosion.

High temperatures can also accelerate corrosion of parts that are not properly ventilated so the moisture can be dispersed. It is particularly important to keep your vehicle clean and free of mud or accumulations of other materials. This applies not only to the visible surfaces but also to the underside of the vehicle.

To help prevent corrosion

You can help prevent corrosion from starting by observing the following:

Keep your vehicle clean

The best way to prevent corrosion is to keep your vehicle clean and free of corrosive materials. Attention to the underside of the vehicle is particularly important.

If you live in a high-corrosion area — where road salts are used, near the ocean, areas with industrial pollution, acid rain, etc.—, you should take extra care to prevent corrosion. In winter, hose off the underside of your vehicle at least once a month and be sure to clean the underside thoroughly when winter is over.

When cleaning underneath the vehicle, pay particular attention to the components under the fenders and other areas that are hidden from view. Do a thorough job. Merely dampening the accu-

mulated mud rather than washing it away will accelerate corrosion rather than prevent it. Water under high pressure and steam are particularly effective in removing accumulated mud and corrosive materials.

When cleaning lower door panels, rocker panels and frame members, be sure that drain holes are kept open so that moisture can escape and not be trapped inside to accelerate corrosion.

Keep your garage dry

Don't park your vehicle in a damp, poorly ventilated garage. This creates a favorable environment for corrosion. This is particularly true if you wash your vehicle in the garage or drive it into the garage when it is still wet or covered with snow, ice or mud. Even a heated garage can contribute to corrosion unless it is well ventilated.

Keep paint and trim in good condition

Scratches or chips in the finish should be covered with "touch-up" paint as soon as possible to reduce the possibility of corrosion. If bare metal is showing through, the attention of a qualified body and paint shop is recommended.

Bird droppings: Bird droppings are highly corrosive and may damage painted surfaces in just a few hours. Always remove bird droppings as soon as possible.

Don't neglect the interior

Moisture can collect under the floor mats and carpeting and cause corrosion. Check under the mats periodically to be sure the carpeting is dry. Take particular

care if you carry fertilizers, cleaning materials or chemicals in the vehicle.

These should be carried only in proper containers and any spills or leaks should be cleaned up, flushed with clean water and thoroughly dried.

Interior care

Use the information in the following sections to maintain the interior of your vehicle.

Interior general precautions

* NOTICE

Prevent chemicals such as perfume, cosmetic oil, sun cream, hand cleaner and air freshener from contacting interior parts because they may cause damage or discoloration. If they contact interior parts, wipe them off immediately. If necessary, use a mixture of warm water and mild non-detergent cleaner (test all cleaners on a concealed area before use). Use proper car cleaner to clean interior parts.

▲ CAUTION

Electrical components

Never allow water or other liquids to contact electrical/electronic components inside the vehicle as this may damage them.

▲ CAUTION

Leather

When cleaning leather products (steering wheel, seats etc.), use neutral detergents or low alcohol content solutions. If you use high alcohol content solutions or acid/alkaline detergents, the color of the

leather may fade or the surface may get stripped.

Taking care of leather seats (if equipped)

- Vacuum the seat periodically to remove dust and sand on the seat. It will prevent abrasion or damage of the leather and maintain its quality.
- Wipe the leather seat cover often with dry or soft cloth.
- Use of a leather protective may prevent abrasion of the cover and helps maintain the color. Be sure to read the instructions and consult a specialist when using leather coating or protectant.
- Leather with bright colors (beige, cream) is easily contaminated and clear in appearance. Clean the seats frequently.
- Avoid wiping with a wet cloth. It may cause the surface to crack.

Cleaning the leather seats (if equipped)

Remove all contaminants instantly. Refer to instructions below for removal of each contaminant.

- Cosmetic products (sunscreen, foundation, etc.)
 - Apply cleaning cream on a cloth and wipe the contaminated area. Wipe off the cream with a wet cloth and remove water with a dry cloth.
- Beverages (coffee, soft drink, etc.)
 - Apply a small amount of neutral detergent and wipe until contaminants do not smear.

- Oil
 - Remove oil instantly with absorbable cloth and wipe with stain remover for leather only.
- Chewing gum
 - Harden the gum with ice and remove gradually.

Fabric seat cover (if equipped)

Please clean the fabric seats regularly with a vacuum cleaner depending on fabric material characteristics. If they are heavily soiled with beverage stains, etc., use a suitable interior cleaner. To prevent damage to seat covers, wipe off the seat covers down to the seams with a large wiping motion and moderate pressure using a soft sponge or microfiber cloth.

Velcro closures on clothing or sharp objects may cause snagging or scratches on the surface of the seats. Do not rub such objects against the surface.

Cleaning the upholstery and interior trim

Car interior surfaces

Remove dust and loose dirt from interior surfaces with a whisk broom or a vacuum cleaner. If necessary, clean interior surfaces with a mixture of warm water and mild non-detergent cleaner (test all cleaners on a concealed area before use).

Fabric

Remove dust and loose dirt from fabric with a whisk broom or vacuum cleaner. Clean with a mild soap solution recommended for upholstery or carpets.

Remove fresh spots immediately with a fabric spot cleaner. If fresh spots do not receive immediate attention, the fabric can stain and its color can be affected. Its fire-resistant properties can be reduced if the material is not properly maintained.

Using anything but recommended cleaners and procedures may affect the fabric's appearance and fire-resistant properties.

Cleaning the lap/shoulder belt webbing

Clean the belt webbing with any mild soap solution recommended for cleaning upholstery or carpet. Follow the instructions provided with the soap. Do not bleach or re-dye the webbing because it may become loose.

Cleaning the interior window glass

If the interior glass surfaces of the vehicle are covered with an oily, greasy or waxy film, they should be cleaned with a glass cleaner. Follow the directions on the glass cleaner container.

CAUTION

Rear window

Do not scrape or scratch the inside of the rear window. This may result in damage of the rear window defroster grid.

Emission control system

The emission control system of your vehicle is covered by a written limited warranty. See the warranty information contained in the Warranty & Consumer Information manual in your vehicle.

Your vehicle is equipped with an emission control system to meet all applicable emission regulations. There are three emission control systems, as follows.

1. Crankcase emission control system
2. Evaporative emission control system
3. Exhaust emission control system

To ensure the proper function of the emission control systems, it is recommended that you have your vehicle inspected and maintained by an authorized Kia dealer in accordance with the maintenance schedule in this manual.

Caution for the Inspection and Maintenance Test (With Electronic Stability Control (ESC) system)

- **To prevent the vehicle from misfiring during dynamometer testing, turn the ESC off by pressing the ESC switch.**
- **After dynamometer testing is completed, turn the ESC back on by pressing the ESC switch again.**

1. Crankcase emission control system

The Positive Crankcase Ventilation (PCV) system is employed to prevent air pollution caused by blow-by gases being emitted from the crankcase. This system supplies fresh filtered air to the crankcase through the air intake hose. Inside the crankcase, fresh air mixes with blow-

by gases, which then pass through the Positive Crankcase Ventilation (PCV) valve into the induction system.

2. Evaporative emission control (including Onboard Refueling Vapor Recovery (ORVR)) system

The ORVR system is designed to prevent fuel vapors from escaping into the atmosphere. The ORVR system is designed to allow the vapors from the fuel tank to be loaded into a canister while refueling at the gas station, preventing the escape of fuel vapors into the atmosphere.

Canister

Fuel vapors generated inside the fuel tank are absorbed and stored in the onboard canister. When the engine is running, the fuel vapors absorbed in the canister are drawn into the surge tank through the Purge Control Solenoid Valve (PCSV).

PCSV

The PCSV is controlled by the Engine Control Module (ECM). When the engine coolant temperature is low during idling, the PCSV closes so that evaporated fuel is not drawn into the engine. After the engine warms up during ordinary driving, the PCSV opens to introduce evaporated fuel to the engine.

3. Exhaust emission control system

The exhaust emission control system is a highly effective system which controls exhaust emissions while maintaining good vehicle performance.

Vehicle modifications

This vehicle should not be modified. Modification of your vehicle could affect its performance, safety or durability and may even violate governmental safety and emissions regulations.

* NOTICE

Damage or performance problems resulting from any modification may not be covered under your warranty.

- If you use unauthorized electronic devices, it may cause the vehicle to operate abnormally, wire damage, battery discharge and fire. Do not use unauthorized electronic devices.

Engine exhaust gas precautions (carbon monoxide)

- Carbon monoxide can be present with other exhaust fumes. If you smell exhaust fumes of any kind inside your vehicle, have it inspected and repaired immediately. If you ever suspect exhaust fumes are entering your vehicle, drive it only with all the windows fully open. Have your vehicle checked and repaired immediately.

⚠ WARNING

Exhaust

Engine exhaust gases contain carbon monoxide (CO). Though colorless and odorless, it is dangerous and could be lethal if inhaled. Follow the instructions on this page to avoid CO poisoning.

- Do not operate the engine in confined or closed areas (such as garages) any more than what is necessary to move your vehicle in or out of the area.
- When your vehicle is stopped in an open area for more than a short time

with the engine running, adjust the ventilation system (as needed) to draw in outside air.

- Never sit in a parked or stopped vehicle for any extended time with the engine running.
- When the engine stalls or fails to start, repeated attempts to restart the engine may cause damage to the emission control system.

Operating precautions for catalytic converters

⚠ WARNING

Catalytic converter

Keep away from the catalytic converter and exhaust system while the vehicle is running or immediately thereafter. The exhaust and catalytic systems are very hot and may burn you.

⚠ WARNING

Fire

- Do not park, idle or drive the vehicle over or near flammable objects, such as grass, vegetation, paper, leaves, etc. A hot exhaust system can ignite flammable items under your vehicle.
- Do not remove the heat sink around the exhaust system, do not seal the bottom of the vehicle and do not coat the vehicle for corrosion control. They may present a fire risk under certain conditions.

Your vehicle is equipped with a catalytic converter emission control device.

The following precautions must be observed:

- Use only UNLEADED FUEL for gasoline engines.

- Do not operate your vehicle when there are signs of engine malfunction, such as misfire or a noticeable under-performance.
- Do not misuse or abuse the engine. Examples of misuse are coasting with the ignition off or descending steep grades in gear with the ignition off.
- Do not operate the engine at high idle speed for extended periods (5 minutes or more).
- Do not modify or tamper with any part of the engine or emission control system. All inspections and adjustments must be made by an authorized Kia dealer.
- Avoid driving with an extremely low fuel level. Running out of fuel could cause the engine to misfire, damaging the catalytic converter.

Failure to observe these precautions could result in damage to the catalytic converter and to your vehicle. This could void your warranties.

Specifications & Consumer information

Dimensions	9-2
Engine	9-3
Gross vehicle weight	9-4
Luggage volume	9-5
Air conditioning system	9-6
Bulb wattage	9-7
Tires and wheels	9-8
Recommended lubricants and capacities	9-9
• Recommended SAE viscosity number.....	9-10
Vehicle Identification Number (VIN)	9-11
Vehicle certification label	9-11
Tire specification and pressure label	9-12
Engine number	9-12
Refrigerant label	9-13
Reporting Safety Defects	9-13

Specifications & Consumer information

Dimensions

4 Door

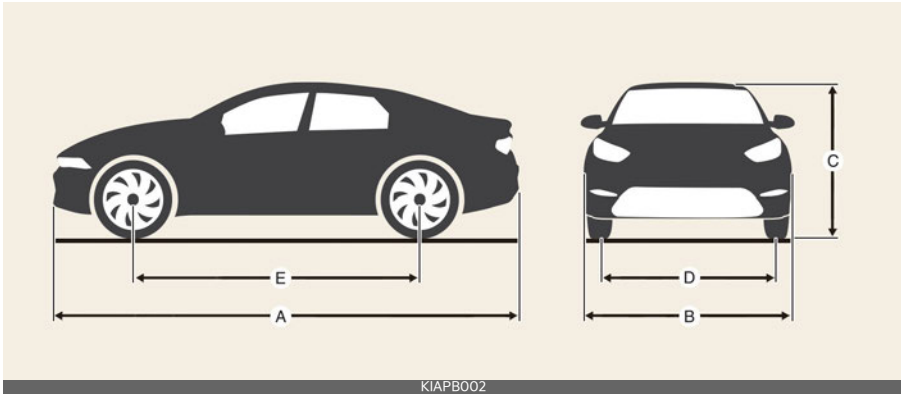

Item		mm (in)	
A	Overall length	4,710 (185)	
B	Overall width	1,850 (72.8)	
C	Overall height	1,420 (55.9) GT-Line: 1,425 (56.1)	
D	Front tread	205/55R16	1,585 (62.4)
		225/45R17	1,579 (62.2)
		235/40R18	1,566 (61.7)
	Rear tread	205/55R16	1,596 (62.8)
		225/45R17	1,590 (62.6)
		235/40R18	1,581 (62.2)
E	Wheelbase	2,720 (107.1)	

Engine

Item	Smartstream G1.6 T-GDi	Smartstream G2.0
Displacement [cc (cu in)]	1,598 (97.5)	1,999 (121.98)
Bore x Stroke [mm (in)]	75.6 x 89 (2.97 x 3.50)	81 x 97 (3.18 x 3.81)
Firing order	1-3-4-2	1-3-4-2
No. of cylinders	4, In-line	4, In-line

Gross vehicle weight

Item	Smartstream G2.0	Smartstream G1.6 T-GDi
Gross vehicle weight [kg (lbs.)]	1,780 (3,924) GT-Line: 1,860 (4,101)	1,900 (4,189)

Luggage volume

Item	Luggage volume
SAE [L(cu.ft)]	413 (14.6)

Air conditioning system

Item	Weight of volume	Classification
Refrigerant [g (oz.)]	500 ± 25 (17.6 ± 0.88)	R-1234yf
Compressor lubricant [g (oz.)]	100 ± 10 (3.5 ± 0.4)	PAG (FD46XG)

Contact an authorized Kia dealer for more details.

Bulb wattage

Light bulb		Bulb type	Wattage (Watt)	
Front	High beam	LED	LED	
	Low beam	LED	LED	
	Side marker	LED	LED	
	Position and daytime running lamps and Turn signal lamps	LED	LED	
	Turn signal lamp (installed in outside rearview mirror)	LED	LED	
	Fog lamp	LED	LED	
Rear	Stop and Turn signal lamps	Type A	P21W	21
	Stop and Turn signal lamps	Type B	LED	LED
	Tail lamps	LED	LED	LED
	Side marker	LED	LED	LED
	Back up lamps	P21W	21	21
	High mounted stop lamps	Type A	P21W	21
		Type B	LED	LED
License plate lamps	LED	LED	LED	
Interior	Map lamps*	LED	LED	
	Room lamps *	LED	LED	
	Vanity mirror lamps *	LED	LED	
	Luggage lamp	FESTOON	5	

Tires and wheels

Item	Tire size	Wheel size	Load capacity		Speed capacity		Inflation pressure [kPa (psi)]				Wheel lug nut torque kgf·m, N·m (lbf·ft)
			L ¹ ²	kg (lbs.)	SS ³	km/h (mph)	Normal load ¹		Maximum load		
							Front	Rear	Front	Rear	
Full size tire	205/55 R16	6.5J x16	91	615 (1,355)	H	210 (130)	235 (34)	215 (31)	235 (34)	215 (31)	11-13, 107-127 (79-94)
	225/45 R17	7.0J x17	91	615 (1,355)	W	270 (168)	235 (34)	215 (31)	235 (34)	215 (31)	
	235/40 R18	8.0J x18	91	615 (1,355)	W	270 (168)	230 (33)	230 (33)	230 (33)	230 (33)	
Compact spare tire	T125/80D15	4T x 15	95	690 (1,521)	M	130 (81)	420 (60)	420 (60)	420 (60)	420 (60)	
	T125/80D16	4T x 16	97	730 (1,609)	M	130 (81)					

*1. Up to 3 persons

*2. Load Index

*3. Speed Symbol

CAUTION

When replacing tires, use the same size originally supplied with the vehicle. Using tires of a different size can damage the related parts or make it work irregularly.

NOTICE

- We recommend that when replacing tires, use the same originally supplied with the vehicles. If not, that affects driving performance.
- When driving in high altitude grades, it is natural for the atmospheric pressure to decrease. Therefore, please check the tire pressure and add more air when necessary. Additionally required tire air pressure per km above sea level: 10.5 kPa (1.5 psi)/km

Recommended lubricants and capacities

To help achieve proper engine and powertrain performance and durability, use only lubricants of the proper quality.

The correct lubricants also help promote engine efficiency that results in improved fuel economy.

These lubricants and fluids are recommended for use in your vehicle.

Lubricant		Volume	Classification
Engine oil (drain and refill) ¹ Kia TotalEnergies	Smartstream G2.0	4.3 L (4.5 US qt.)	Full synthetic SAE 0W-20, API SN PLUS/SP or ILSAC GF-6
	Smartstream G1.6 T-GDi	4.8 L (5.07 US qt.)	
Automatic transmission (AT) fluid ²	Smartstream G1.6 T-GDi	6.5 L (6.87 US qt.)	SK ATF SP4M-1, MICHANG ATF SP4M-1, S-OIL ATF SP4M-1, Kia Genuine ATF SP4M-1
Intelligent Variable Transmission (IVT) fluid ²	Smartstream G2.0	6.5 L (6.87 US qt.)	MICHANG SP-CVT1, Kia genuine oil ATF SP-CVT1
Coolant ³	Smartstream G2.0	6.0 L (6.34 US qt.)	A Phosphate based ethylene glycol based coolant
	Smartstream G1.6 T-GDi	7.2 L (7.6 US qt.)	
Brake fluid		As required	SAE J1704 DOT-4 LV, ISO4925 CLASS-6, FMVSS116 DOT-4
Fuel ⁴	Smartstream G2.0	47 L (12.41 US gal.)	Gasoline
	Smartstream G1.6 T-GDi		

* 1. Refer to "Recommended SAE viscosity number" on page 9-10.

* 2. Use only specified genuine automatic transmission fluid. The use of non-specified (even marked as compatible with genuine) could result in shift quality deterioration and vibrations, eventually, the transmission failure. (Refer to "Scheduled maintenance service" on page 8-8)

* 3. Different type of coolant or water may damage the electrical component.

* 4. To maintain your vehicle's best brake and ABS/ESC performance, use Kia genuine brake fluid as in the specification.

Recommended SAE viscosity number

⚠ CAUTION

Always be sure to clean the area around any filler plug, drain plug, or dipstick before checking or draining any lubricant. This is especially important in dusty or sandy areas and when the vehicle is used on unpaved roads. Cleaning the plug and dipstick areas will prevent dirt and grit from entering the engine and other mechanisms that could be damaged.

Engine oil viscosity (thickness) has an effect on fuel economy and cold weather operating (engine start and engine oil flowability). Lower viscosity engine oils can provide better fuel economy and cold weather performance, however, higher viscosity engine oils are required for satisfactory lubrication in hot weather.

Using oils of any viscosity other than those recommended could result in engine damage.

* NOTICE

Never add any additives to the engine oil. Engine oil additives can change its properties of engine oil and may cause serious engine failure.

When choosing an oil, consider the range of temperature your vehicle will be operated in before the next oil change. Proceed to select the recommended oil viscosity from the chart.

Temperature Range for SAE Viscosity Numbers

A: Smartstream G1.6 T-GDi & Smartstream 2.0

TEMP.	°C	-30	-20	-10	0	10	20	30	40	50
	°F	-10	0	20	40	60	80	100	120	
A					0W-20					



An engine oil displaying this American Petroleum Institute (API) Certification Mark conforms to the International Lubricant Specification Advisory Committee (ILSAC). It is recommended to only use engine oils that uphold this API Certification Mark.

Vehicle Identification Number (VIN)

The Vehicle Identification Number (VIN) is the number used in registering your vehicle and in all legal matters pertaining to its ownership, etc.

VIN cover (if equipped)



The VIN is also on a plate attached to the top of the dashboard. The number on the plate can easily be seen through the windshield from outside.

VIN label



Vehicle certification label



The vehicle certification label attached on the driver's (or front passenger's) side center pillar gives the vehicle identification number (VIN).

Tire specification and pressure label



The tires supplied on your new vehicle are chosen to provide the best performance for normal driving.

The tire label located on the driver's side center pillar gives the tire pressures recommended for your vehicle.

Engine number

The engine number is stamped on the engine block as shown in the drawing.

Smartstream G2.0

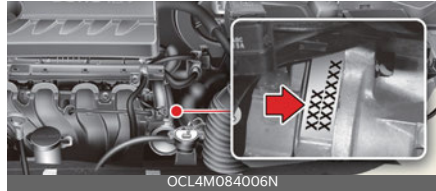

Smartstream G1.6 T-GDi



Refrigerant label



The refrigerant label is located on the underside of the hood.

Reporting Safety Defects

If you believe that your vehicle has a defect which could cause a crash or could cause injury or death, you should immediately inform Transport Canada (TC) in addition to notifying **Kia Canada Inc.**

Mailing Address:

Transport Canada - ASFAD
330 Sparks Street
Ottawa, ON
K1A 0N5

Telephone: 819-420-4300 (Ottawa-Gatineau area or internationally)

Toll free: 1-800-333-0510 (in Canada)

Online:

<http://www.tc.gc.ca/recalls>

If TC receives similar complaints, it may open an investigation, and if it finds that a safety defect exists in a group of vehicles, it may order a recall and remedy campaign. However, TC cannot become involved in individual problems between you, your dealer, or **Kia Canada Inc.**

Abbreviations **A**

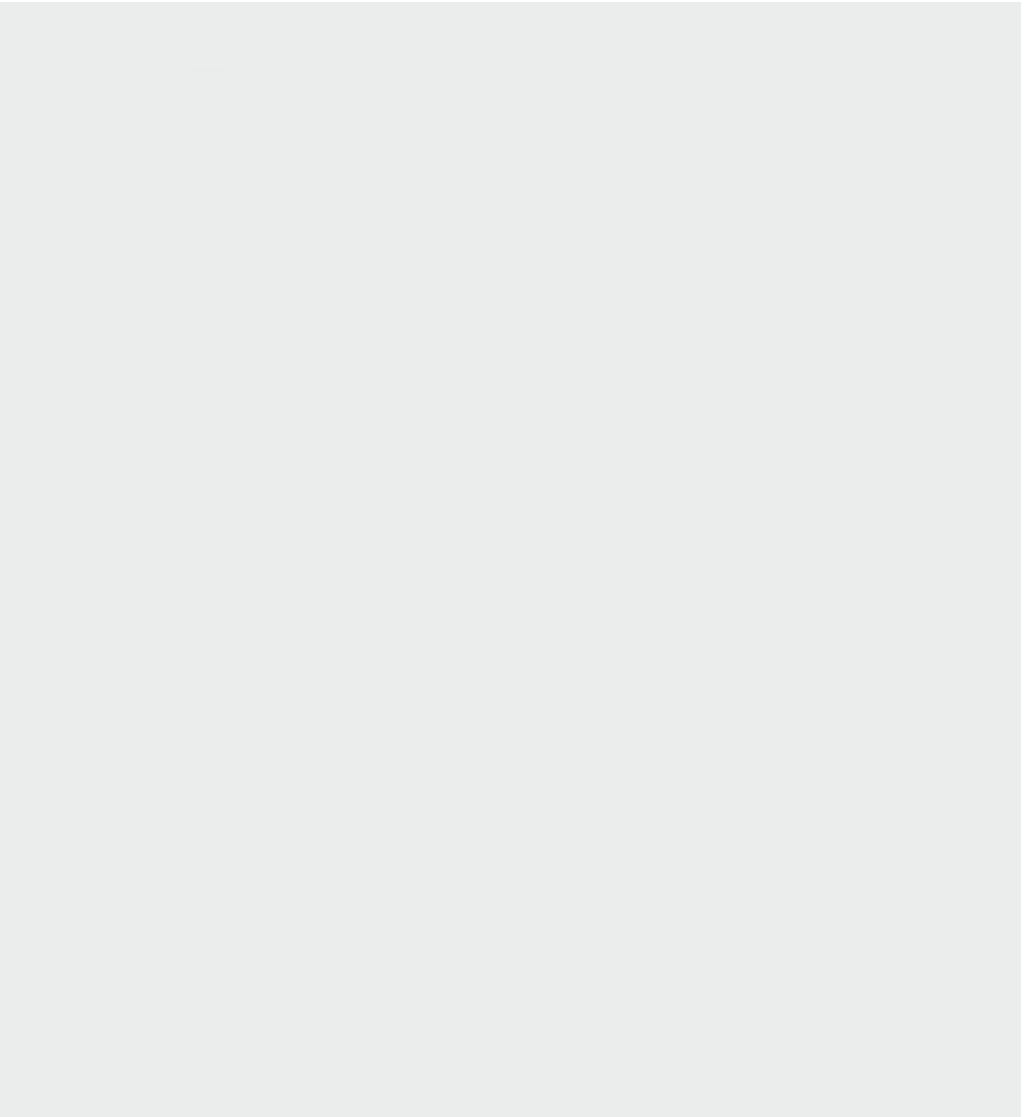

Abbreviations

ABS

Anti-lock Brake System

BCA

Blind-Spot Collision-Avoidance Assist

BCW

Blind-Spot Collision Warning

CC

Cruise Control

CRS

Child Restraint System

DAW

Driver Attention Warning

DRL

Daytime Running Light

EBD

Electronic Brake force Distribution

ECM

Electric Chromic Mirror

ESC

Electronic Stability Control

FCA

Forward Collision-Avoidance Assist

HAC

Hill-start Assist Control

HBA

High Beam Assist

HDA

Highway Driving Assist

HMSL

High Mounted Stop Lamp

HUD

Head-Up Display

LATCH

Lower Anchors and Tether for Children

LFA

Lane Following Assist

LKA

Lane Keeping Assist

MDPS

Motor Driven Power Steering

MIL

Malfunction Indicator Lamp

NSSC

Navigation-based Smart Cruise Control

ODS

Occupant Detection System

PCA

Reverse Parking Collision-Avoidance Assist

PDW

Reverse Parking Distance Warning

RCCA

Rear Cross-Traffic Collision-Avoidance Assist

RCCW

Rear Cross-Traffic Collision Warning

Abbreviations

ROA

Rear Occupant Alert system

RVM

Rear View Monitor

SBW

Shift-By-Wire

SCC

Smart Cruise Control

SEA

Safe Exit Assist

SEW

Safe Exit Warning

SRS

Supplemental Restraint System

SRSCM

SRS Control Module

SVM

Surround View Monitor

TBT

Turn By Turn

TCS

Traction Control System

TIN

Tire Identification Number

TPMS

Tire Pressure Monitoring System

VIN

Vehicle Identification Number

VSM

Vehicle Stability Management

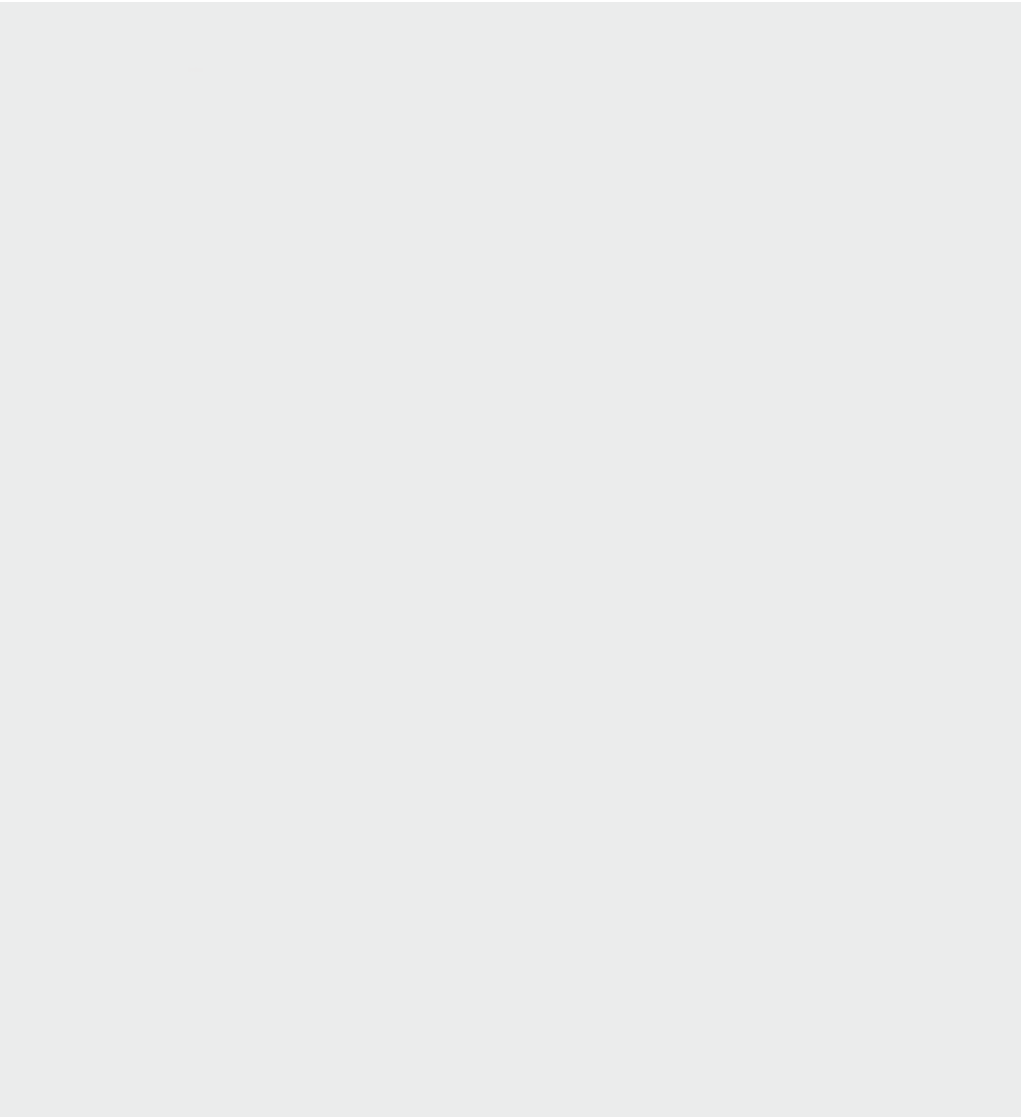

Index

Numerics

360° camera monitoring system 6-93

A

air cleaner filter 8-22
replacing air cleaner filter 8-22
air ventilation seat 4-118
airbag warning label 3-52
airbags 3-33
adding equipment to or modifying your airbag-equipped vehicle 3-52
additional safety precautions 3-51
airbag collision sensors 3-47
airbag warning label 3-52
curtain airbag 3-46
driver's and passenger's front airbag 3-43
inflation conditions 3-48
non-inflation conditions 3-49
occupant detection system (ODS) 3-38
operation of the system 3-34
side airbag 3-44
SRS components and functions 3-36
supplemental restraint system (SRS) 3-50
warning light 3-35
antenna 4-126
anti-lock brake system (ABS) 5-30
appearance care 8-52
exterior care 8-52
interior care 8-57
armrest 3-14
auto defogging system 4-112
auto hold 5-28
automatic climate control system 4-102
adjusting the driver and passenger side temperature to the same value 4-106
automatic air ventilation 4-108
controlling automatically 4-106
controlling the temperature heating and air conditioning manually 4-103
automatic transmission 5-16

ignition key interlock system 5-20
LCD display for warning message 5-11, 5-17
manual mode 5-19
operation 5-16
shift-lock system 5-13, 5-19, 5-20

B

battery 8-26
for best battery service 8-26
blind-spot collision-avoidance assist (BCA) 6-31
malfunction and limitations 6-36
operation 6-34
settings 6-32
blind-spot view monitor (BVM) 6-55
malfunction 6-56
operation 6-56
settings 6-55
brake fluid 8-19
checking the brake fluid level 8-19
brake system 5-22
anti-lock brake system (ABS) 5-30
auto hold 5-28
electronic parking brake (EPB) 5-24
electronic stability control (ESC) system 5-32
hill-start assist control (HAC) 5-35
power brakes 5-22
vehicle stability management (VSM) system 5-34
bulb replacement precaution 8-49
bulb wattage 9-7

C

child restraint system (CRS) 3-25
installing a CRS 3-28
selecting a CRS 3-26
types 3-27
child-protector rear door lock 4-21
climate control air filter 8-23
inspecting and replacing climate control air filter 8-23
climate control system 4-93
operation 4-93
closing the hood 4-47

cup holder 4-116

D

day/night rearview mirror 4-59

declaration of conformity 4-127, 6-123

defogging (windshield) 4-110

manual climate control system 4-111

defrosting (windshield)

manual climate control system 4-111

digital key 2 4-23

card key 4-28

personalized profile and vehicle settings 4-30

smart phone 4-23

used vehicle/digital key 2

maintenance 4-33

door locks 4-17

child-protector rear door lock 4-21

door lock/unlock features 4-21

in case of an emergency 4-22

operating door locks from inside the vehicle 4-19

rear occupant alert (ROA) 4-22

with the mechanical key 4-18

with the smart key 4-17

drive mode 5-37

drive mode integrated control system 5-37

drive mode 5-37

driver attention warning (DAW) 6-51

malfunction and limitations 6-53

operation 6-51

settings 6-51

E

economical operation 5-38

electric Chromic Mirror (ECM) 4-59

electronic parking brake (EPB) 5-24

applying the parking brake 5-24

EPB malfunction 5-27

EPB warning messages 5-26

releasing the parking brake 5-25

electronic stability control (ESC) system 5-32

emergency 7-2

emergency starting 7-4

hazard warning flasher 7-2

if engine doesn't turn over or turns

over slowly 7-3

if engine turns over normally but does

not start 7-3

if the engine stalls at a crossroad or

crossing 7-2

if the engine will not start 7-3

if the vehicle stalls while driving 7-2

if you have a flat tire while driving 7-2

in case of an emergency while driving 7-2

road warning 7-2

emergency starting

jump-starting 7-4

push-starting 7-5

emission control system 8-59

engine coolant 8-17

changing the coolant 8-19

checking the coolant level 8-18

engine number 9-12

engine oil and filter 8-15

changing the engine oil and filter 8-16

checking the engine oil level 8-15

engine overheats 7-6

engine start/stop button 5-7

engine start/stop button position 5-7

illuminated engine start/stop button 5-7

starting the engine 5-8

F

flat tire 7-11

changing tires 7-13

jack and tools 7-11

jack label 7-18

removing and storing the spare tire 7-12

using of compact spare tire 7-16

forward collision-avoidance

assist (FCA) 6-4

malfunction and limitations 6-18

operation 6-9

settings 6-7

forward/reverse parking

distance warning (PDW) 6-106

malfunction and precautions 6-108

operation 6-107

settings	6-106
forward/side/reverse parking distance warning (PDW)	6-111
settings	6-112
fuel filler door	4-48
closing the fuel filler door	4-49
opening the fuel filler door	4-48
fuel gauge	4-64
fuel requirements	1-2
fuses	8-39
fuse/relay panel description	8-42
replacing engine compartment fuse	8-41
replacing inner panel fuse	8-40

G

gauges	4-63
distance to empty	4-65
engine coolant temperature gauge	4-64
fuel gauge	4-64
odometer	4-65
outside temperature gauge	4-66
speedometer	4-63
tachometer	4-63
glove box	4-115
good braking practices	5-35

H

hazardous driving conditions	5-40
headlight (low beam)	4-84
heated steering wheel	4-57
heated washer nozzle	4-89
high beam assist (HBA)	4-86
highway driving assist (HDA)	6-79
malfunction and limitations	6-87
operation	6-81
settings	6-80
hill-start assist control (HAC)	5-35
hood	4-46
closing the hood	4-47
hood open warning	4-47
opening the hood	4-46
hood open warning	4-47
horn	4-58

I

illuminated engine start/stop button	5-7
immobilizer system	4-12
folding key immobilizer system	4-12
smart key immobilizer system	4-13
infotainment system	4-124
instrument cluster	4-62
adjusting instrument cluster illumination	4-63
integrated memory system	4-34
intelligent speed limit assist (ISLA)	
malfunction and limitations	6-49
operation	6-47
settings	6-46
intelligent variable transmission (IVT)	5-10
good driving practices	5-14
interior features	4-116
interior light	4-91
automatic turn off function	4-91
luggage room lamp	4-92
map lamp	4-91
room lamp	4-92
vanity mirror lamp	4-92

J

jump-starting	7-4
----------------------	-----

K

key positions	
ignition switch position	5-5
keys	4-6
battery replacement	4-6
remote key	4-7
smart key	4-9

L

lane following assist (LFA)	6-75
malfunction and limitations	6-78
operation	6-76
settings	6-76
lane keeping assist (LKA)	6-25

malfunction and limitations	6-28
operation	6-27
settings	6-26
LCD display	4-67
LCD display modes	4-67
LCD display modes	4-67
driving assist mode	4-68
information mode	4-68
turn by turn (TBT) mode	4-68, 4-69

LCD displays	
LCD display messages	4-70
light bulbs	8-49
replacing lights (LED type)	8-51
lighting	4-82
auto light	4-84
battery saver function	4-82
daytime running light (DRL)	4-83
headlamp delay function	4-82
headlight (low beam)	4-84
high beam assist (HBA)	4-86
lighting control	4-83
one-touch lane change	4-85
operating front fog light	4-85
operating high beam	4-84
operating turn signals and lane change signal	4-85
position & tail lamp	4-84
luggage net holder	4-116

M

maintenance	
engine compartment	8-3
maintenance services	8-5
owner maintenance	8-6
scheduled maintenance items	8-12
scheduled maintenance service	8-8
manual climate control system	4-97
air conditioning	4-101
controlling air intake	4-100
controlling fan speed	4-101
heating and air conditioning	4-98
mode selection	4-99
temperature control	4-99
manual speed limit assist (MSLA)	6-44
operation	6-44
map lamp	4-91

mirrors	4-58
electric Chromic Mirror (ECM)	4-59
inside rearview mirror	4-58
outside rear view mirror	4-59
motor driven power steering (MDPS)	4-55

N

navigation-based smart cruise control (NSCC)	6-70
limitations	6-72
operation	6-71
settings	6-71

O

occupant detection system (ODS)	3-38
odometer	4-65
one-touch lane change	4-85
opening the hood	4-46
operating high beam	4-84
outside rear view mirror	4-59
outside temperature gauge	4-66
overloading	5-49
owner maintenance	8-6

P

panoramic sunroof	4-52
automatic reversal	4-53
resetting the sunroof	4-54
slide open/close	4-53
sunshade	4-52
tilt open/close	4-53
power brakes	5-22
power outlet	4-120
power window lock button	4-45
pre-tensioner seat belt	3-21
push-starting	7-5

R

rear cross-traffic collision-avoidance assist (RCCA)	6-98
malfunction and limitations	6-102

operation	6-99	seat warmer	4-117
settings	6-98	seatback pocket	3-13
rear occupant alert (ROA)	4-22	smart cruise control (SCC)	6-57
rear view monitor (RVM)	6-89	display and control	6-62
malfunction and limitations	6-92	malfunction and limitations	6-66
operation	6-90	settings	6-58, 6-59
settings	6-89	smart key	4-9
recommended SAE viscosity		mechanical key	4-11
number	9-10	operation	4-9
refrigerant label	9-13	smart trunk	4-38
remote key	4-7	detecting area	4-40
mechanical key	4-8	how to deactivate	4-40
operation	4-7	how to use	4-38
transmitter precautions	4-8	special driving conditions	5-40
replacing lights (LED type)	8-51	driving at night	5-40
reverse parking collision-		driving in flooded areas	5-41
avoidance assist (PCA)	6-117	driving in the rain	5-41
malfunction and limitations	6-119	hazardous driving conditions	5-40
operation	6-118	highway driving	5-41
settings	6-117	hydroplaning	5-41
		rocking the vehicle	5-40
		smooth cornering	5-40
		specifications	9-2
S		air conditioning system	9-6
safe exit warning (SEW)	6-40	dimensions	9-2
malfunction and limitations	6-42	engine	9-3
operation	6-41	gross vehicle weight	9-4
settings	6-40	lubricants and capacities	9-9
safety precautions	3-3	luggage volume	9-5
seat	3-5	tires and wheels	9-8
front seat adjustment for manual seat	3-8	speedometer	4-63
front seat adjustment for power seat	3-9	starting the engine	5-8
front seat headrest	3-11	steering wheel	4-55
rear seat adjustment	3-13	heated steering wheel	4-57
seat leather	3-7	horn	4-58
seatback pocket	3-13	motor driven power steering (MDPS)	4-55
seat belts	3-16	tilt & telescopic steering wheel	4-56
3-point system with emergency		storage compartment	4-115
locking retractor	3-18	center console storage	4-115
care of seat belts	3-24	glove box	4-115
child restraint system (CRS)	3-25	luggage net holder	4-116
front passenger and rear seat 3-point		sun visor	4-119
system with combination locking		supplemental restraint system	
retractor	3-19	(SRS)	3-50
precautions	3-22	surround view monitor (SVM)	
pre-tensioner seat belt	3-21	malfunction and limitations	6-97
seat belt restraint system	3-16	operation	6-94
warning	3-17	settings	6-93
seat leather	3-7		

T

tachometer	4-63
theft-alarm system	4-14
armed stage	4-14
disarmed stage	4-16
theft-alarm stage	4-15
tilt & telescopic steering wheel	4-56
tire pressure monitoring system (TPMS)	7-7
effective use of the TPMS	7-7
low tire pressure telltale	7-8
tire replacement with TPMS	7-9
TPMS malfunction indicator	7-9
tire specification and pressure label	9-12
tires and wheels	8-29
all season tires	8-37
checking tire inflation pressure	8-30
low aspect ratio tire	8-38
radial-ply tires	8-37
snow tires	8-37
summer tires	8-37
tire maintenance	8-32
tire replacement	8-31
tire rotation	8-30
tire sidewall labeling	8-32
tire terminology and definitions	8-35
tire traction	8-32
wheel alignment and tire balance	8-31
wheel replacement	8-32
towing	7-19
without wheel dollies	7-19
trunk	4-36
closing the trunk	4-37
emergency trunk safety release	4-37
opening the trunk	4-36
turn signal	4-85

U

USB charger	4-119
USB port	4-126

V

vehicle break-in process	1-5
---------------------------------	-----

vehicle certification label	9-11
vehicle data collection and event data recorders	1-6
vehicle identification number (VIN)	9-11
vehicle load limit	5-45
vehicle modifications	1-4
vehicle stability management (VSM) system	5-34
vehicle weight	5-48

W

warning and indicator lights	4-73
indicator lights	4-79
warning lights	4-73
washer fluid	8-21
checking the washer fluid level	8-21
welcome system	4-90
door handle lamp	4-90
headlight (headlamp) escort function	4-90
interior light	4-91
windows	4-42
power window lock button	4-45
remote window opening	4-45
window opening and closing	4-43
windshield defrosting and defogging	4-110
A/C automatic drying	4-114
defogging inside windshield with automatic climate control	4-111
defogging logic	4-113
defrosting outside windshield with automatic climate control	4-112
winter driving	5-42
snow tires	5-42
snowy or icy conditions	5-42
wiper blades	8-24
front windshield wiper blade	8-24
wipers and washers	4-88
heated washer nozzle	4-89
operating windshield washers	4-89
wireless smart phone charging system	4-121

