

# OWNER'S MANUAL

Operation

Maintenance

Specifications

All information in this Owner's Manual is current at the time of publication. However, HYUNDAI reserves the right to make changes at any time so that our policy of continual product improvement may be carried out.

This manual applies to all models of this vehicle and includes descriptions and explanations of optional as well as standard equipment.

As a result, you may find material in this manual that does not apply to your specific vehicle.

## **CAUTION: MODIFICATIONS TO YOUR HYUNDAI**

Your HYUNDAI should not be modified in any way. Such modifications may adversely affect the performance, safety or durability of your HYUNDAI and may, in addition, violate conditions of the limited warranties covering the vehicle. Certain modifications may also be in violation of regulations established by the Department of Transportation and other government agencies in your country.

## **TWO-WAY RADIO OR CELLULAR**

Your vehicle is equipped with a Tire Pressure Monitoring System, Passenger Occupant Classification System and other CAN bus systems. It is possible for an improperly installed/adjusted high powered two-way radio to adversely affect electronic systems. For this reason, we recommend that you carefully follow the radio manufacturer's instructions if you choose to install one of these devices.

---

## SAFETY AND VEHICLE DAMAGE WARNING

This manual includes information titled as DANGER, WARNING, CAUTION and NOTICE. These titles indicate the following:

### **DANGER**

DANGER indicates a hazardous situation which, if not avoided, will result in death or serious injury.

---

### **WARNING**

WARNING indicates a hazardous situation which, if not avoided, could result in death or serious injury.

---

### **CAUTION**

CAUTION indicates a hazardous situation which, if not avoided, could result in minor or moderate injury.

---

### **NOTICE**

NOTICE indicates a situation which, if not avoided, could result in vehicle damage.

---

## HYUNDAI VEHICLE OWNER PRIVACY POLICY

Your Hyundai vehicle may be equipped with technologies and services that use information collected, generated, recorded or stored by the vehicle. Hyundai has created a Vehicle Owner Privacy Policy to explain how these technologies and services collect use and share this information.

You may read our Vehicle Owner Privacy Policy on the Hyundaiusa.com website at: <https://www.hyundaiusa.com/owner-privacy-policy.aspx>

If you would like to receive a hard copy of our Vehicle Owner Privacy Policy, please contact the Hyundai Customer Care Center at:

Hyundai Customer Care  
P.O. Box 20850  
Fountain Valley, CA 92728  
800-633-5151  
[consumeraffairs@hmausa.com](mailto:consumeraffairs@hmausa.com)

Hyundai's Customer Care representatives are available Monday through Friday, between the hours of 6:00 AM and 5:00 PM PST and Saturday between 6:30 AM and 3:00 PM PST (English).

For Customer Care assistance in Spanish or Korean, representatives are available Monday through Friday between 6:30 AM and 3:00 PM PST.

## Table of contents

Introduction/Getting started with Your Electric Vehicle	1
Vehicle Information, Consumer Information, and Reporting Safety Defects	2
Seats & Safety System	3
Instrument Cluster	4
Convenience Features	5
Driving Your Vehicle	6
Driver Assistance System	7
Emergency Situations	8
Maintenance	9
Index	I



# 1. Introduction/Getting started with Your Electric Vehicle

Introduction .....	1-3
HYUNDAI Motor America.....	1-3
Guide to HYUNDAI Genuine Parts .....	1-4
How to Use This Manual .....	1-5
Safety Messages .....	1-6
Vehicle Modifications.....	1-7
Vehicle Data Collection and Event Data Recorders.....	1-7
About "Getting Started with Your Electric Vehicle" .....	1-8
Understanding Your Electric Vehicle .....	1-9
Characteristics of Your Electric Vehicle .....	1-9
Precautions When Using the High Voltage Battery.....	1-11
Other Precautions for Electric Vehicle Management.....	1-12
Charging Your Electric Vehicle .....	1-13
Safety Precautions for Charging Your Electric Vehicle .....	1-13
Checking Basic Information on Charging Your Electric Vehicle .....	1-16
Using an AC Charger.....	1-22
Using a DC Charger.....	1-25
Using a Portable Charger (ICCB) .....	1-27
Using EV Mode Functions .....	1-34
Checking the EV Mode Screen Configuration .....	1-34
Checking Energy Information .....	1-35
Setting the Next Departure Time.....	1-37
Setting Scheduled Charging and Climate.....	1-38
Setting a Battery Discharging Limit When Using Vehicle to Load (V2L).....	1-40
Setting Electric Vehicle Specialized Functions.....	1-41
Using V2L Function.....	1-46
Safety Precautions When Using the V2L Function .....	1-46
Using Electricity Outside the Vehicle .....	1-48
Using Electricity Inside the Vehicle .....	1-49
Solving V2L Problems .....	1-51
Aux. Battery Saver+ .....	1-52
Driving Your Electric Vehicle .....	1-53
Starting and Stopping the Vehicle.....	1-53
Checking Electric Vehicle Driving Information.....	1-54

Countermeasures for Accidents or Fire .....	1-64
If the Electric Vehicle Catches Fire .....	1-64
If the Electric Vehicle Is Submerged.....	1-64
If the Electric Vehicle Needs Towing .....	1-65
Other Precautions for Electric Vehicle Accidents .....	1-66



## Introduction

Congratulations, and thank you for choosing HYUNDAI. We are pleased to welcome you to the growing number of discerning people who drive HYUNDAs. We are very proud of the advanced engineering and high-quality construction of each HYUNDAI we build.

Your Owner's Manual will introduce you to the features and operation of your new HYUNDAI. To become familiar with your new HYUNDAI, so that you can fully enjoy it, read this Owner's Manual carefully before driving your new vehicle.

This manual contains important safety information and instructions intended to familiarize you with your vehicle's controls and safety features so you can safely operate your vehicle.

This manual also contains information on maintenance designed to enhance safe operation of the vehicle. It is recommended that all service and maintenance on your car be performed by an authorized HYUNDAI dealer. HYUNDAI dealers are prepared to provide high-quality service, maintenance and any other assistance that may be required.

This Owner's Manual should be considered a permanent part of your vehicle, and should be kept in the vehicle so you can refer to it at any time. The manual should stay with the vehicle if you sell it to provide the next owner with important operating, safety and maintenance information.

## HYUNDAI MOTOR AMERICA

### CAUTION

Severe vehicle damage may result from the use of poor quality lubricants that do not meet HYUNDAI specifications. You must always use high quality lubricants that meet the specifications listed in the Vehicle Specifications section of the Owner's Manual.

Copyright 2024 HYUNDAI Motor America. All rights reserved. No part of this publication may be reproduced, stored in any retrieval system or transmitted in any form or by any means without the prior written permission of HYUNDAI Motor America.

## GUIDE TO HYUNDAI GENUINE PARTS

### 1. What are HYUNDAI Genuine Parts?

HYUNDAI Genuine Parts are the same parts used by HYUNDAI Motor Company to manufacture vehicles. They are designed and tested for the optimum safety, performance, and reliability for our customers.



### 2. Why HYUNDAI Genuine Parts?

HYUNDAI Genuine Parts are engineered and built to meet rigid manufacturing requirements.

Damage caused by using imitation, counterfeit or used salvage parts is not covered under the HYUNDAI New Vehicle Limited Warranty or any other HYUNDAI warranty.

In addition, any damage to or failure of HYUNDAI Genuine Parts caused by the installation or failure of an imitation, counterfeit or used salvage part is not covered by any HYUNDAI Warranty.



### 3. How can you tell if you are purchasing HYUNDAI Genuine Parts?

Look for the HYUNDAI Genuine Parts Logo on the package (see below).

HYUNDAI Genuine Parts exported to the U.S. are packaged with labels written only in English.

HYUNDAI Genuine Parts are only sold through authorized HYUNDAI Dealerships.

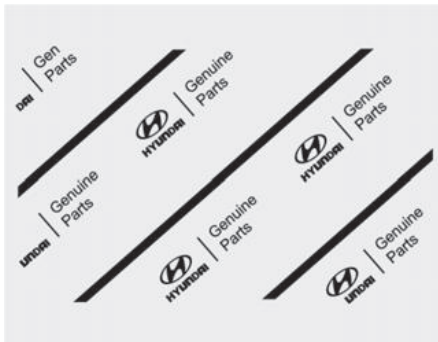

## HOW TO USE THIS MANUAL

We want to help you get the greatest possible driving pleasure from your vehicle. Your Owner's Manual can assist you in many ways. We strongly recommend that you read the entire manual. In order to minimize the chance of death or injury, you must read the WARNING and CAUTION sections in the manual.

Illustrations complement the words in this manual to best explain how to enjoy your vehicle. By reading your manual, you will learn about features, important safety information, and driving tips under various road conditions.

The general layout of the manual is provided in the Table of Contents. Use the index when looking for a specific area or subject; it has an alphabetical listing of all information in your manual.

Sections: This manual has nine chapters plus an index. Each section begins with a brief list of contents so you can tell at a glance if that section has the information you want.

## SAFETY MESSAGES

Your safety, and the safety of others, is very important. This Owner's Manual provides you with many safety precautions and operating procedures. This information alerts you to potential hazards that may hurt you or others, as well as damage your vehicle.

Safety messages found on vehicle labels and in this manual describe these hazards and what to do to avoid or reduce the risks.

Warnings and instructions contained in this manual are for your safety. Failure to follow safety warnings and instructions can lead to serious injury or death.

Throughout this manual DANGER, WARNING, CAUTION, NOTICE and the SAFETY ALERT SYMBOL will be used.



This is the safety alert symbol. It is used to alert you to potential physical injury hazards. Obey all safety messages that follow this symbol to avoid possible injury or death. The safety alert symbol precedes the signal words DANGER, WARNING and CAUTION.

### **DANGER**

DANGER indicates a hazardous situation that, if not avoided, will result in death or serious injury.

---

### **WARNING**

WARNING indicates a hazardous situation that, if not avoided, could result in death or serious injury.

---

### **CAUTION**

CAUTION indicates a hazardous situation that, if not avoided, could result in minor or moderate injury.

---

### **NOTICE**

NOTICE indicates a situation that, if not avoided, could result in vehicle damage.

---

## VEHICLE MODIFICATIONS

- This vehicle should not be modified. Modification of your vehicle could affect its performance, safety or durability and may even violate governmental safety and emissions regulations.

In addition, damage or performance problems resulting from any modification may not be covered under warranty.

- If you use unauthorized electronic devices, it may cause the vehicle to operate abnormally, wire damage, battery discharge and fire. For your safety, do not use unauthorized electronic devices.

### NOTICE

Some vehicle interior sounds (including welcome sound, navigation alerts, or warning sound) may be generated from the interior speakers and amplifier. Do not replace these components with anything other than the original HYUNDAI factory parts. Any unauthorized product may cause a malfunction of the vehicle interior sounds that may affect the intended operation of the vehicle.

## VEHICLE DATA COLLECTION AND EVENT DATA RECORDERS

This vehicle is equipped with an event data recorder (EDR). The main purpose of an EDR is to record, in certain crash or near crash-like situations, such as an airbag deployment or hitting a road obstacle, data that will assist in understanding how a vehicle's systems performed. The EDR is designed to record data related to vehicle dynamics and safety systems for a short period of time, typically 30 seconds or less.

The EDR in this vehicle is designed to record such data as:

- How various systems in your vehicle were operating;
- Whether or not the driver and passenger safety belts were buckled/ fastened;
- How far (if at all) the driver was depressing the accelerator and/or brake pedal; and,
- How fast the vehicle was traveling.

These data can help provide a better understanding of the circumstances in which crashes and injuries occur.

NOTE: EDR data are recorded by your vehicle only if a nontrivial crash situation occurs; no data are recorded by the EDR under normal driving conditions and no personal data (for example, name, gender, age, and crash location) are recorded. However, other parties, such as law enforcement, could combine the EDR data with the type of personally identifying data routinely acquired during a crash investigation.

To read data recorded by an EDR, special equipment is required, and access to the vehicle or the EDR is needed. In addition to the vehicle manufacturer, other parties, such as law enforcement, that have the special equipment, can read the information if they have access to the vehicle or the EDR.

## About "Getting Started with Your Electric Vehicle"

"Getting started with your electric vehicle" provides information about new technologies applied to the vehicle and explains how to use the main features. "Getting started with your electric vehicle" allows you to quickly and easily understand new vehicle features and how to operate them conveniently.

- Before driving, carefully read the manual provided with the vehicle and follow all safety information and precautions for every vehicle feature.
- "Getting started with your electric vehicle" covers all optional specifications. It may include descriptions for features that are not equipped in the vehicle.
- Images of the exterior and interior of the vehicle in "Getting started with your electric vehicle" may differ from the actual vehicle.

## Understanding Your Electric Vehicle

Electric vehicles are driven using a battery and an electric motor. Understand the characteristics of your electric vehicle and check the features that you must know before driving it.

### Characteristics of Your Electric Vehicle

The characteristics that differentiate electric vehicles from gasoline vehicles are as follows:

- Electric vehicles are eco-friendly because they do not use fossil fuels for driving. Additionally, unlike gasoline vehicles, noise and vibration are minimal, and the vehicle's lifespan is relatively long.
- When slowing down or driving downhill, regenerative braking is used. Regenerative braking charges the high voltage battery and minimizes energy loss.
- If the high voltage battery is running low, you can charge the vehicle using the AC charger, DC charger, or portable charging cables. For more information, refer to the "Charging Your Electric Vehicle" section in this chapter.

#### *i* Information

Regenerative braking uses an electric motor when decelerating and braking, and it transforms kinetic energy to electrical energy in order to charge the high voltage battery.

#### **Battery information**

The batteries used in the electric vehicle are as follows:

- **High voltage battery (high capacity):** Drives the motor and operates the air conditioner and heater. It can be charged via an AC charger, DC charger, or portable charger.
- **12 V battery:** Operates all lights, wipers, and audio system. The 12 V battery charge can also be maintained by the high voltage battery at parked condition at certain conditions.

### ***Main components of your electric vehicle***

The main components of your electric vehicle and their functions are as follows:

- **On-Board Charger (OBC):** Charges the high voltage battery by converting the power grid's AC power to DC power.
- **Inverter:** Converts power from direct current (DC) to alternating current (AC) and supplies power to the motor, and converts power from AC to DC to charge the high voltage battery during deceleration and braking.
- **Low Voltage DC-DC Converter (LDC):** Converts the high voltage battery's power source to a low voltage (12 V) power source for supply of power to the electrical devices on the vehicle.
- **Vehicle Control Unit (VCU):** Controls the various controllers and sensors on the vehicle.
- **Motor:** Uses electricity accumulated on the high voltage battery to drive the vehicle (same role as an engine in gasoline vehicles).
- **Gear:** Delivers the rotational force of the motor to the tires at appropriate speeds and torque.
- **High voltage battery (Lithium-ion battery):** Stores and supplies power necessary for the electric vehicle to operate. (The separately installed 12 V battery provides power to the vehicle when the vehicle is in ACC or OFF.)

#### **WARNING**

- Do not remove or disassemble any high voltage battery's connectors and wires. Doing so may lead to accidents, such as electric shock, and result in serious injury and significantly degrade the vehicle's performance and durability.
  - When the high voltage battery or its related components require inspection and maintenance, contact an authorized HYUNDAI dealer.
-



## Precautions When Using the High Voltage Battery

Precautions for high voltage battery when driving and storing the vehicle are as follows:

### CAUTION

- Keep the gauge of the high voltage battery from going below 10 %. Storing the vehicle while the battery level is too low for a long time may damage the battery or reduce the battery's capacity.
  - If a collision occurs and the vehicle is impacted, have the vehicle inspected by an authorized HYUNDAI dealer and check the battery connection status.
  - Using the V2L function may reduce the driving distance due to the use of high voltage battery energy, and repeated use of the V2L function may impact battery life.
  - Frequent use of DC charging may impact battery life.
- 
- The high voltage battery level may reduce naturally even if the vehicle is not driven.
  - Storing the vehicle in temperatures that are too hot or cold may degrade the battery performance.
  - The distance to empty or power output may vary depending on the driving conditions, such as the outside temperature. Driving on highway at high speeds or uphill will increase battery consumption, resulting in a shorter distance to empty.
  - If you use the air conditioner or heater, which is powered by the high voltage battery, the distance to empty will be reduced. Maintain reasonable temperature when using the air conditioner or heater to maximize distance to empty.
  - Depending on the vehicle's period of use, natural degradation of the battery may occur that reduces distance to empty over long period of vehicle life. When the charge capacity and distance to empty keep failing, have the vehicle inspected by an authorized HYUNDAI dealer.
  - If you do not use the vehicle for a long time, charge the vehicle at least once every three months to prevent both the high voltage and the 12 V battery from fully discharging. When the battery level has low level, immediately charge the vehicle.
  - Using AC charging as much as possible can help keep the battery in optimal condition. Fully charging the battery when it is 20 % or lower helps to keep the battery in optimal condition. (Charging once a month or more is recommended.)
  - The charging level value displayed on the instrument cluster may decrease according to the charging conditions (charger status, outside temperature, battery temperature, etc.). For longer battery life and safety, after a certain charging level is reached, the charging current is gradually lowered to fully charge the battery.

## Other Precautions for Electric Vehicle Management

### CAUTION

- When heat treatment after repairs or painting is applied to the vehicle due to an accident, the high voltage battery's performance may be degraded. If heat treatment is required, contact an authorized HYUNDAI dealer.
  - When cleaning the motor compartment, do not use a high pressure washer. Doing so may result in electric shock, due to a discharge in high voltage electricity, or damage the vehicle's electric system.
  - Do not install third-party parts or modified parts on the vehicle. Doing so may damage the electric power system. Only use or install genuine parts.
- 

### ***High voltage cut-off switch***

High voltage cut-off switch is a device located inside the motor compartment to block the battery's high voltage when your vehicle is inspected at an authorized HYUNDAI dealer.

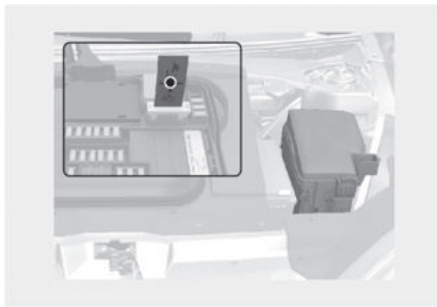

### WARNING

- Never touch the high voltage cut-off switch. This could result in serious injury or death in a collision or electric shock.
  - If the high voltage cut-off switch requires an inspection or repair, contact an authorized HYUNDAI dealer.
  - Never disconnect or cut the high voltage cut-off switch except in an emergency situation. Serious problems may occur, such as the vehicle may not start.
-

## Charging Your Electric Vehicle

Check the detailed information about charging an electric vehicle and charge your vehicle.

Electric vehicles can be charged via an AC charger or DC charger installed at public charging stations. If the vehicle cannot be moved to a public charging station in the event of an emergency, you can charge the vehicle via the In-Cable Control Box (ICCB) with a power source (AC 120 V).

To find a nearby public charging station, refer to the “Searching for nearby charging stations” in this chapter.

## Safety Precautions for Charging Your Electric Vehicle

Before charging your electric vehicle, read and comply with all the safety information below. Failure to do so may cause electric shock or fire and result in a serious injury, death, vehicle malfunction, or property damage.

### ***Precautions for electric medical devices***

#### **WARNING**

Electromagnetic waves that are generated from the charger can seriously impact electric medical devices, such as an implantable cardiac pacemaker. When using such devices, make sure to consult with your doctor and the manufacturer to find out whether charging your electric vehicle will impact the operation of your device.

---

### ***Basic safety precautions for charging***

#### **WARNING**

- Before charging, apply the Electronic Parking Brake (EPB) with the brake pedal pressed, shift to P (Park) and turn off the vehicle. Movement of the vehicle while charging may result in death, serious injury, or property damage.
- Use UL certified electric vehicle charger only. Failure to do so may damage the charger, charging cable, or vehicle. Also, it may lead to safety hazards, such as fire, explosion, etc.
- To avoid death, serious injury, or property damage electric shock and fire, follow the instructions below:
  - Do not touch the interior of the charging connector, charging plug, or the vehicle charging inlet when connecting the cable to the charger and the charging inlet on the vehicle.
  - Do not touch the charging connector and charging plug with wet hands, or when standing in water or snow while connecting the charging cable.
  - When connecting or removing the charging cable, you must hold the charging connector handle and charging plug.

- Use a waterproof charger. Do not charge the vehicle in a place where rainwater may come in contact with the joints of the charging cable connector and the charging plug.
  - Ensure there is no water, dust, or other contaminants on the charging cable connector and the charging plug.
  - Immediately stop charging if you feel abnormal conditions, such as odor or smoke.
  - Do not charge the vehicle if there is a risk of lightning.
- 

### **i** Information

- While charging, the gear cannot be shifted from P (Park) to any other gear.
  - Ensure the vehicle door is unlocked before disconnecting the charging connector. The release button on the charging connector does not work when the vehicle door is locked.
  - To control the temperature of the high voltage battery while charging or when the battery temperature is high, the air conditioning is used to cool down the battery. It may generate noise or vibration from operation of the air conditioning compressor and cooling fan, but this is a normal condition when charging the high voltage battery.
  - The cooling system may be operated when using the air conditioner during charging. This may degrade the air conditioner's performance temporarily.
  - Depending on the condition and durability of the high voltage battery, charger specifications and condition, and ambient temperature, the time required for charging the battery and distance to empty may vary.
  - In rare cases, you might hear high-frequency noise (a small beeping sound) outside the vehicle when charging with a 400 V DC charger that has deteriorated or has long communication delay. The high-frequency noise can be generated only when the vehicle tries to reduce its own electromagnetic waves to keep DC charging as stable as possible. This beep sound does not affect the charging performance or the vehicle itself.
- 

### **Precautions for operating the cooling fan**

#### **WARNING**



Do not put your hand near the cooling fan in the motor compartment while charging. It may operate automatically to control the battery temperature, even if the vehicle is turned off.

---

### ***Precautions for operating the charging door***

Before operating the charging door, carefully read and follow all the safety information below.

#### **⚠ CAUTION**

- Before opening the charging door in the opening direction, ensure that there is no interference with nearby objects.
  - When opening and closing the charging door, be careful not to get your hands or other body parts caught in the door.
  - If you cannot open the charging door due to freezing weather, lightly tap or remove any ice near the charging door.
  - Do not try to forcibly open the charging door. It may cause damage to the charging door or cause a malfunction.
  - Do not hold the parts that support the charging door. Damage to parts or deformation of parts may cause vehicle damage and accidents.
- 

### ***Precautions for using, handling, and storing the charging cable***

#### **Precautions when using the charging cable**

#### **⚠ CAUTION**

- To prevent electric shock, replace the charging cable if the coating or the connector is damaged.
  - Do not modify or disassemble the charging cable. Doing so may result in fire, electric shock, or injury.
  - Do not pull or twist the charging cable excessively, and ensure that the cable is not twisted. Power cuts or damage to the cable's insulation sheath may result in electric shock or fire.
  - Do not drag the charging cable on the floor or place objects on it. Damage to the insulation of the cable may result in electric shock or fire.
  - Do not use the charging cable near a heat source or heating appliance.
  - Do not drop or subject the charging cable to a strong impact. Also, ensure no water or liquid comes into contact with the cable.
  - Use the charging cable only when there are no children around.
  - If there is any sign of damage, corrosion, or rust on the charging connector and plug, or if the connection of the charging connector and plug feels loose, do not use the cable. Have the vehicle inspected by an authorized HYUNDAI dealer.
-

### Precautions when handling and storing the charging cable

#### CAUTION

- Always keep the charging connector and plug dry and clean.
- Ensure that the connectors, plugs, and control box (portable charger) of the charging cable are not submerged or in contact with water.
- Keep the charging cable free from water or moisture, and keep it in the cargo storage compartment.
- Do not keep the charging cable near heat source or heating appliances.
- Keep the charging cable away from children.
- If there is dust or contaminants inside the charging connector or plug, remove it using the air gun.
- If the charging cable is contaminated, completely disconnect the cable from the charger or power, and remove the contaminants.
  - Wipe the charging cable lightly with the soft cloth soaked with a 3 % neutral detergent aqueous solution, then use a clean cloth to completely remove moisture and dry the cable in a well-ventilated shade.
  - When removing contaminants, ensure the charging connector and charging plug are not in contact with water.
  - Do not use organic solvents, such as benzene, paint thinner, or detergent. Doing so may cause deformation, discoloration, or malfunction of charging cable.
  - When using a vehicle decontamination agent, ensure that the product does not contain organic solvents, such as benzene, paint thinner, or detergent.

---

## Checking Basic Information on Charging Your Electric Vehicle

Before charging your vehicle, check and understand the information such as the expected charging time according to the charge type, checking the State of Charge (SOC), and setting the charger lock mode.

### ***Checking charging type and charging time***

The charge types for electric vehicle are as follows:

- **AC charge:** The electric vehicle is charged via a Level 2 AC public charger or professionally installed home charger.
- **DC charge:** You can charge at high speeds at public charging stations. Refer to the respective company's charger app or online information that is provided for each DC charger type.
- **Portable charge:** If the vehicle cannot be moved to a public charging station due to a lack of battery power, the vehicle can be charged with household electricity, using the 120 V ICCB portable charger included with the vehicle.

## *i* Information

Type 3R enclosure satisfies the requirements of UL 50E standard when the charging connector is connected to the vehicle side charging inlet. An additional Type 3R enclosure should be provided in the end installation of the vehicle side charging inlet. The "Type 3R" marking can be found on the charging inlet.

- What is type 3R?: Performance requirement for enclosures intended for outdoor use that provides a degree of protection against falling dirt, rain, sleet, and/or snow.
- 

## CAUTION

- Risk of electric shock. Do not disconnect under load.
  - Suitable for use on a circuit capable of delivering not more than 5,000 rms symmetrical Amperes, 120 V AC Maximum.
  - Suitable for use on a circuit capable of delivering not more than 30,000 rms symmetrical Amperes, 1,000 V DC Maximum.
- 

## CAUTION

- Battery performance and life may deteriorate if the DC charger is used constantly. It is best to occasionally use AC charger to optimize battery life.
  - The electrical outlet at home must comply with regulations and can safely accommodate the Voltage, Current (Amps), and Power (Watts) ratings specified on the portable charger. If not, the vehicle may not be charged or safety hazards, such as fire, may occur.
  - If the power distributor exceeds its capacity while charging the vehicle with a portable charger at home, the power to home may be cut off or a fire may occur.
  - If you use a portable charger to charge your electric vehicle with household electricity, you will be charged on your household electricity bill.
-

The estimated charging time for each charging type is as follows:

Charging Type		Charging Time		Charge Level (Minimum-Maximum)	Charging Condition (Temperature)
		Standard Battery Type	Extended Battery Type		
AC charge		About 5 hours 20 minutes	About 7 hours 10 minutes	10-100 %	Room temperature(77 °F)
DC charge	350 kW	About 18 minutes	About 18 minutes	10-80 %	
	50 kW	About 58 minutes	About 66 minutes	10-80 %	
Portable charge (ICCB: In-Cable Control Box)		About 46 hours 40 minutes	About 68 hours	10-100 %	

**i Information**

- The DC charging time may be longer at cold temperature below 20 ° (-17 °).
- Depending on the condition and durability of the high voltage battery, charger specifications, and ambient temperature, the time required for charging the high voltage battery may vary.
- If the charger is worn out, exposed, or there exists any type of damage, charging may stop for your safety. Use another charger that works normally.
- When charging the battery, an additional 3 minutes may be required to check battery condition.







### Checking the charging status

Check the State of Charge (SOC) of the high voltage battery via the charge indicator light inside the charging door.

1. With the vehicle door unlocked, press the open indicator on the charging door to open the charging door.
2. Check the SOC referring to the charge indicator light inside the charging door.
  - SOC is indicated in 4 levels.



Charge indicator light	SOC [%]
	0-24 %
	25-49 %
	50-74 %
	75-100 %

### Checking information on the charging label

Open the charging door and check the information on the charging label on the right side of the charging connector. The charging label shows safety symbols and the rated input specifications for charging.

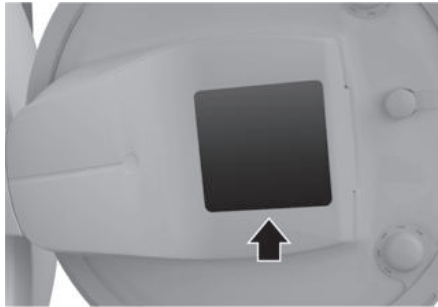

No.	Name	Description
(1)	Warning for high voltage	Indicates a device with a risk of electric shock.
(2)	Warning/Caution symbol	Indicates a device that may cause property damage, serious injury or death if not operated carefully.
(3)	Rated voltage and maximum charging current	Indicates the type of input current (~, AC) and the rated voltage range (V) and charging current (A) when AC charging.

## ***When the electric charging door closes automatically***

**+** if equipped

The electric charging door closes automatically after certain time in the following conditions. Check the operation conditions and reset the charging door if it does not open under normal use conditions.

- When the charging connector is disconnected.
- When the charging door is opened and charging has not started.
- When the gear is shifted to D (Drive), N (Neutral), or R (Reverse).

### **Resetting the electric charging door**

If the electric charging door malfunctions or if the 12 V battery has been replaced, reset the charging door by turning the vehicle on and off once.

- If the charging door malfunctions continuously after resetting the charging door, have the vehicle inspected by an authorized HYUNDAI dealer.

### **Setting charging connector locking mode**

You can lock the charging connector during AC charging to prevent unintended detachment of the charging connector from the vehicle.

#### ***i* Information**

The connector is automatically locked during DC charging or while using the V2L function, regardless of the settings of charging connector locking mode applied to the vehicle.

- When DC charging is complete, the charging connector will be unlocked automatically.
- After using electricity, you can unlock the charging connector by pressing the switch on the V2L connector to turn off the power and unlock the vehicle door.

On the infotainment system, select **EV** > **⚙️ (EV Setting)** > **Charging Connector Locking Mode** to set the locking mode of the charging connector.

The available locking mode options are as follows:

- **Always:** Locks the connector automatically whenever the charging connector is plugged into the charging inlet.
- **While Charging:** Locks the connector automatically only while charging is in progress after the charging connector is properly connected to the vehicle. This is the preferred setting when using public stations to allow for other customers to use charger after your vehicle is done charging.
- **Do Not Lock:** Unlocks the connector regardless of the charging state. Be careful of portable charging cable theft.

### Disconnecting the charging connector in an emergency

If the unlock button is not functioning properly due to a discharged battery or abnormal electrical wiring, the charging connector cannot be disconnected from the vehicle.

#### CAUTION

Do not disconnect the charging connector forcibly. Doing so may damage the charging connector or the charging inlet on the vehicle.

---

If the charging door does not open due to battery being fully discharged or a wiring failure, open the trunk and pull the emergency cable on the trunk's right wall.

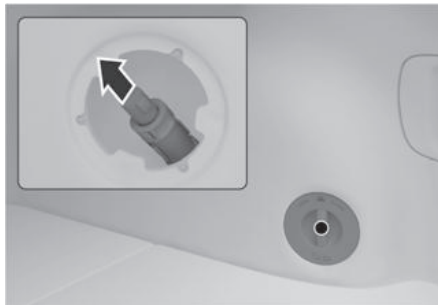

- If the unlock button still does not operate after pulling the emergency cable, have the vehicle inspected by an authorized HYUNDAI dealer.

## Using an AC Charger

AC charging is the most common charging method for electric vehicles. Charge your electric vehicle using an AC charging cable installed in public charging stations or at your professionally installed Level 2 AC home charger.

- To find a nearby public charging station, refer to the "Searching for nearby charging stations" section in this chapter.

#### WARNING

Before charging the vehicle, carefully read and follow the instructions in "Safety Precautions for Charging Your Electric Vehicle" to prevent property damage or injury due to electric shock, fire, explosion, etc.

---

**⚠ CAUTION**

To prevent property damage or injury due to fire or explosion, follow the instructions below.

- Only use the genuine AC charging cable provided by the manufacturer (if equipped).
- Try to avoid using an extension cord, but if you must use to reach a 120 V outlet, ensure it is a medium to heavy duty grounded extension cord rated at 15 A minimum.
- Check the rated voltage and maximum charging current required for charging, and ensure that the charger power you are using meets the requirements.
- Immediately stop charging if you discover abnormal conditions, such as odor or smoke.

***Understanding the AC charging cable***

The exterior and configuration of the AC charging cable are as follows:

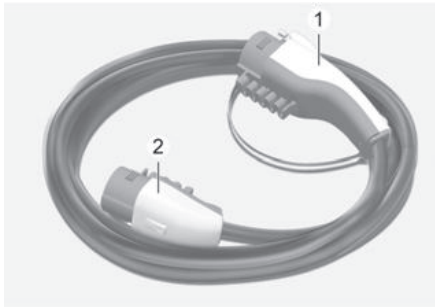

- (1) Charging connector (Vehicle side)  
(2) Charging plug (Charger side)

***Charging with an AC charger***

Follow the instructions below to charge the vehicle with an AC charger.

1. With the vehicle started, apply the Electronic Parking Brake (EPB) while pressing the brake pedal.
2. Turn all switches off, shift to P (Park), and stop the vehicle.
3. With the vehicle door unlocked, press the open indicator on the charging door to open the charging door.
4. Open the charging inlet cover and check the charging connector and charging inlet for dust or other contaminants
  - If there is any dirt or contaminants, remove it using the air gun.

 **WARNING**

Do not touch the charging connector of the charging cable or the charging inlet on the vehicle.

---

5. Remove the charging connector protection cap of the AC charging cable, hold the charging connector handle, and connect it to the AC charging inlet on the vehicle. Push it until you hear a click.
6. **[If using separately purchased charging cable]** Remove the charging plug protection cap of the AC charging cable, hold the charging plug handle, and connect it to the electric outlet (120 V) of the AC charger.
  - This process is required only when using a separately purchased AC charging cable. If you use a charging cable installed in an AC charger, a separate charging plug connection is not required.
  - When charging starts, the estimated charging time will be displayed on the instrument cluster for about one minute.

*i* **Information**

- If you open the driver's door while charging, the estimated charging time will also be displayed on the instrument cluster for about one minute.
  - When scheduled charging is set, a message saying "Waiting to charge at scheduled time" will be displayed.
  - When scheduled air conditioner or heater operates while waiting for the scheduled charging, the estimated charging time will be displayed as "-".
- 
7. **[If using a separately purchased charging cable]** When charging is complete, hold the charging plug handle, disconnect the charging plug from the electric outlet (120 V) of the AC charger, and close the protection cap of the charging plug.
    - This process is required only when using an AC charging cable purchased separately. If you use a charging cable installed in an AC charger, a separate charging plug disconnection is not required.
  8. Hold the charging connector handle with the unlock button pressed, and pull the charging connector to disconnect it from the charging inlet.

 **CAUTION**

Do not forcibly disconnect the charging connector without pressing the unlock button on the charging connector. It may damage the charging connector or the charging inlet on the vehicle.

---

9. Close the charging inlet cover and press the charging door to completely close it.

## *i* Information

- If the charging connector locking mode is set to **Always** or **While Charging**, unlock the door by pressing the button on the smart key or the button on the driver's door, and disconnect the charging connector from the charging inlet.
    - For more information, refer to the "Setting charging connector locking mode" section in this chapter.
  - During AC charging, the quality of radio reception may degrade in some areas.
- 

## Using a DC Charger

If you need to charge the vehicle in a shorter time, you can charge at high speeds using a DC charger installed in public charging stations.

- To find a nearby charging station, refer to the "Searching for nearby charging stations" section in this chapter.

## WARNING

Before charging the vehicle, carefully read and follow the instructions in "Setting charging connector locking mode" to prevent property damage or injury due to electric shock, fire, explosion, etc.

---

## CAUTION

Battery performance and life may deteriorate if the DC charger is used constantly. Use AC charging unless DC charging is necessary.

---

### **Understanding the DC charging connector**

The exterior of the DC charging cable is as follows:



- (1) DC charging connector (Vehicle side)

### **Charging with a DC charger**

Follow the instructions below to charge the vehicle with a DC charger.

1. With the vehicle started, apply the Electronic Parking Brake (EPB) while pressing the brake pedal.
2. Turn all switches off, shift to P (Park), and stop the vehicle.
3. With the vehicle door unlocked, press the open indicator on the charging door to open the charging door.
4. Open the charging inlet cover and check the charging connector and charging inlet for dust or other contaminants.
  - If there is any dirt or contaminants, remove it using the air gun.

#### **⚠ WARNING**

Do not touch the interior of the charging connector of the charging cable or the charging inlet on the vehicle.

---

5. Remove the charging connector protection cap of the DC charging cable, hold the charging connector handle, and connect it to the DC charging inlet on the vehicle. Push it until you hear a click.
  - When charging starts, the estimated charging time will be displayed on the instrument cluster for a minute.

#### **i Information**

If you open the driver's door while charging, the estimated charging time will also be displayed on the instrument cluster for a minute.

---



6. When charging is complete, hold the charging connector handle with the unlock button pressed and pull on the charging connector to disconnect it from the charging inlet.
  - Depending on the DC charger types, some DC chargers may not have a charger connector unlock button so it may be necessary to stop at the DC charger control panel or by charger company's app.

### CAUTION

Before disconnecting the charging connector, check if there is an unlock button on the connector handle. If the connector handle is equipped with an unlock button, forcibly disconnecting the connector without pressing the button may damage the charging connector or charging inlet on the vehicle.

---

### NOTICE

- For more information, refer to the “Setting charging connector locking mode” section in this chapter.
- 

7. Close the charging inlet cover.
8. Press the charging door to completely close it.

## Using a Portable Charger (ICCB)

If the vehicle cannot be moved to a public charging station, you can charge the vehicle using a separately purchased In-Cable Control Box (ICCB) in places where general power (AC 120 V) is supplied.

### WARNING

Before charging the vehicle, carefully read and follow the instructions in “Setting charging connector locking mode” to prevent property damage or injury due to electric shock, fire, explosion, etc.

---

**⚠ CAUTION**

To prevent property damage or injury due to fire or explosion, follow the instructions below.



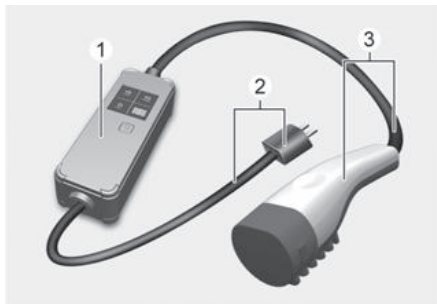

- Only use a genuine HYUNDAI portable charger (if equipped).
  - Do not let children operate or touch the portable charger. Doing so may lead to unexpected accidents.
  - Try to avoid using an extension cord, but if you must use to reach a 120 V outlet, ensure it is a medium to heavy duty grounded extension cord rated at 15 A minimum.
  - The charger power you are using must comply with regulations and safely accommodate the Voltage, Current (Amps), and Power (Watts) ratings. If not, the vehicle may not be charged or safety hazards, such as fire, may occur.
  - If the power distributor exceeds its capacity while charging the vehicle with a portable charger at home, the power to the home may be cut off or a fire may occur.
  - Immediately stop charging if you discover abnormal conditions, such as odor or smoke.
  - Use a portable charger only in emergencies, and do not use it to fully charge the battery.
  - If you charge the vehicle with household electricity, you will be charged electricity bill according to the home rate system, not the electric vehicle rate system.
- 

***Understanding portable chargers***

The configuration of a portable charger and the display of the operation indicator are as follows:



- (1) Control box
- (2) Power plug and cord (cord set)
- (3) Charging cable and charging connector

Icon	Name	Color	Description
	POWER	Green	Turns on when the power is on.
	CHARGE	Blue	Turns on while charging and blinks when current is limited (Forcibly switched to 6 A).
	FAULT	Red	Blinks when a leakage current, communication error, or overcurrent error occurs, or when the high-temperature protection inside the plug and charger is activated.
	CHARGE LEVEL	-	Displays the present charging current setting (6 A, 8 A, 10 A, or 12 A).

Icon	Name		Color	Description
	E1	Control pilot communication	-	Vehicle communication error
	E2	Leakage	-	Current leakage
	E3		-	Charger error
	E4	Plug temperature	-	Plug overtemperature warning
	E5		-	Plug temperature failure
	E6		-	Charger error
	E7	Overcurrent	-	Charging overcurrent warning
	E8	Internal temperature	-	Charger overheating
	E9		-	Charger error
	F1	Relay fusion	-	Charger error
	F2	Ground Monitoring/Interrupt	-	Poor grounding of outlet
	F3	Switched mode power supply power failure	-	Switched mode power supply error (voltage failure)
	F4		-	Switched mode power supply error (abnormal voltage)
	F5	Control Pilot voltage error	-	Control Pilot (-) voltage error
	F6		-	Control Pilot (+) voltage error
	F7	Temperature sensor error	-	Plug temperature sensor error
F8	-		PCB internal temperature sensor error	

- If an error occurs, you can reset the portable charger by disconnecting and reconnecting the power plug, and then pressing the button on the control box for more than two seconds.
- If the same symptom repeats after resetting the portable charger, have the vehicle inspected by an authorized HYUNDAI dealer.
- If there is no status change for more than one minute, the portable charger will be switched to power saving mode, and the display light will be turned off.

### Charging with a portable charger

Follow the instructions below to charge the vehicle with a portable charger.

1. Connect the power plug of the portable charger to the electrical outlet at your home.
  - The power indicator light on the control box will turn green.
2. Set the charging current by pressing the button on the back of the control box for more than two seconds until the number on the charging current indicator blinks.

#### NOTICE

An example of a portable charger charging current setting suitable for the rated current of the power supplied is as follows. However, the appropriate charging current may vary depending on the environment, such as the power usage inside the building.

Outlet Current	ICCB Charge level
14-16 A	12 A
12-13 A	10 A
10-11 A	8 A
8-9 A	6 A

- The charging current is changed each time the button is pressed, in the order of "6 A - 8 A - 10 A - 12 A."
- If 10 seconds have passed without pressing any button, the blinking will stop and the charging current will be finished.

3. With the vehicle started, apply the Electronic Parking Brake (EPB) while pressing the brake pedal.
4. Turn all switches off, shift to P (Park), and stop the vehicle.
5. With the vehicle door unlocked, press the open indicator on the charging door to open the charging door.
6. Open the charging inlet cover and check the charging connector and charging inlet for dust or other contaminants.
  - If there is any dirt or contaminants, remove it using the air gun.

#### WARNING

Do not touch interior of the charging connector of the charging cable or the charging inlet of the vehicle.

7. Remove the charging connector protection cap of the portable charging cable, hold the charging connector handle, and connect it to the AC charging inlet of the vehicle. Push it until you hear a click.

- When charging starts, the estimated charging time will be displayed on the instrument cluster for about one minute.

### *i* Information

- If you open the driver's door while charging, the estimated charging time will also be displayed on the instrument cluster for about one minute.
- When scheduled charging is set, a message saying "Waiting to charge at scheduled time" will be displayed.
- When scheduled air conditioner or heater operates while waiting for the scheduled charging, the estimated charging time will be displayed as '-'.

---

8. When charging is complete, hold the charging connector handle with the unlock button pressed and pull on the charging connector to disconnect it from the charging inlet.

### *i* Information

If you have set the charging connector locking mode as **Always** or **While Charging**, unlock the door by pressing the button on the smart key or the button on the driver's door, and disconnect the charging connector from the charging inlet.

- For more information, refer to the "Setting charging connector locking mode" section in this chapter.

---

9. Close the charging inlet cover.

10. Press the charging door to completely close it.

### **Using the scheduled charging function**

The scheduled charging function allows you to charge your vehicle using low cost, late night power until the next departure time.

#### ***i* Information**

You can use the scheduled charging function only when using an AC charger or the portable charger (ICCB: In-Cable Control Box). For more information about connecting an AC charger and portable charger, refer to the “Using an AC Charger” and “Using a Portable Charger (ICCB)” section in this chapter.

On the infotainment system, select **EV > Scheduled Charging and Climate > Scheduled Charging**, set the date and time of when to charge the battery, and select an option.

- For more information, refer to the “Setting Scheduled Charging and Climate” section in this chapter.
- When scheduled charging is set and the AC charger or the portable charger (ICCB) is connected for charging, the indicator light gradually illuminates for three minutes to indicate that scheduled charging is set.
- When scheduled charging is set, charging is not started immediately when the AC charger or portable charger (ICCB) is connected. To charge the vehicle immediately, select **EV > Scheduled Charging and Climate > Scheduled Charging** on the screen and deactivate the scheduled charge setting.

#### ***i* Information**

- You can set up or cancel scheduled charging using the HYUNDAI BlueLink app on your smartphone. For more information, refer to the user's manual provided in the infotainment system and the quick reference guide.
- Charging may start immediately after a charger is connected to the vehicle, depending on the charging time calculated when setting up the scheduled charging.

## Using EV Mode Functions

EV mode provides driving information and high voltage battery information. You can set various electric vehicle functions in EV mode.

### Checking the EV Mode Screen Configuration

Follow the instruction below to enter EV mode and check the screen configuration.

1. On the infotainment system, swipe the Home screen to the left to display the All menus screen.
2. On the All menus screen, select **EV**.
  - The EV mode screen appears.

The details of the EV mode screen is as follows:

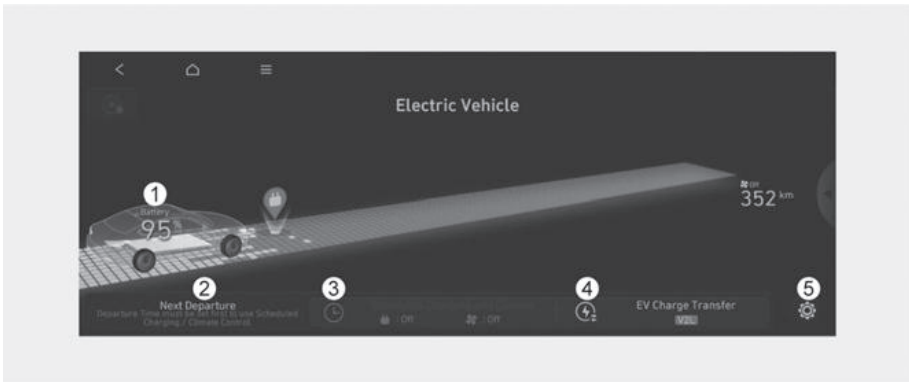

No.	Name	Description
(1)	Energy information	You can check the distance to empty, total battery power remaining, and expected charging time for each charge type.
(2)	Next departure time	You can set anticipated departure time for scheduled charging and target temperature.
(3)	Scheduled charging and climate control	You can set the date and time of when to charge the battery and the climate control temperature. Also, you may select the time to start charging using the off-peak time setting.
(4)	Vehicle to Load (V2L) setting	You can set the battery discharging limit (%) for the high voltage battery for driving.
(5)	EV setting	You can set various electric vehicle specialized functions. For more information, refer to the “Setting Electric Vehicle Specialized Functions” section in this chapter.



## Checking Energy Information

Check the distance to empty, State of Charge (SOC), and expected charging time and charge the vehicle if necessary.

- For more information about charging the vehicle, refer to the “Charging Your Electric Vehicle” section in this chapter.
1. On the infotainment system, swipe the Home screen to the left to display the All menus screen.
  2. On the All menus screen, select **EV** and select the vehicle image.
  3. On the Energy Information screen, select each item to check the vehicle energy information.

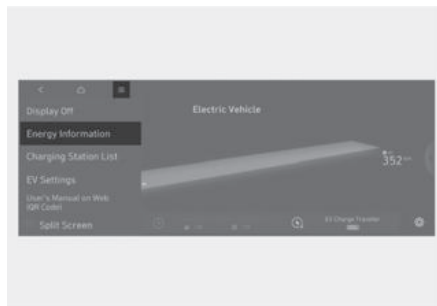

### **Checking the battery status**

On the Energy Information screen, select **Battery Status**.

- You can check the current charge level, expected distance to empty, and charging time for each charge type.
- For more information about setting target battery charge level, refer to the “Setting the target battery charge level” section in this chapter.

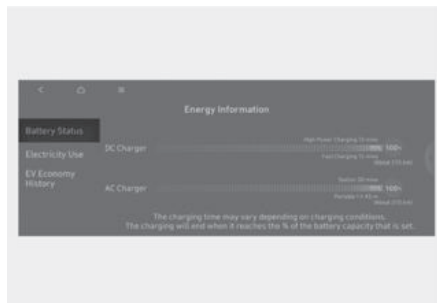

**i Information**

- The distance to empty is calculated based on the electric energy economy history and outside temperature while driving. The distance may change if the driving pattern changes.
- The distance to empty may vary depending on the change of the driving pattern even if the same target battery charge level is set.

**Checking electricity use**

On the Energy Information screen, select **Electricity Use**.

- You can check the current energy consumption for each vehicle system.



No.	Name	Description
(1)	Electronics	Shows the power and energy consumption used by the vehicle system, including the instrument cluster, infotainment system (speaker and navigation), headlight, vehicle control unit, etc., and the percentage of the power vehicle system used in total power used since starting the vehicle.
(2)	Climate	Shows the power and energy consumption used by the air conditioner or heater and the percentage of the power climate system used in total power used since starting the vehicle.
(3)	Drive train	Shows the percentage of instantaneous and regenerative energy consumed by the motor to drive the vehicle and the percentage of the power driving system used in total power used since starting the vehicle.
(4)	Battery Care	Shows the momentary power and energy consumption used when increasing and cooling down the battery temperature to maintain optimal battery performance and the percentage of battery temperature control mode (Battery Care mode) used in the total power used since starting the vehicle.

### ***Checking the electric energy economy history***

On the Energy Information screen, select **EV Electricity History**.

- You can check the history of electric energy economy with the date and distance of previous driving.



### **Setting the Next Departure Time**

You can set an anticipated departure time for scheduled charging and target temperature.

#### ***i* Information**

- Scheduled charging and climate will be activated based on the departure time.
- To use scheduled charging and climate function, the vehicle must be connected to the charger at the scheduled time.
- The scheduled climate function directly uses the power of the connected charger. It can maintain a pleasant environment and enhance vehicle performance by controlling the temperature of the vehicle and the battery without using the high voltage battery power.

1. On the infotainment system, swipe the Home screen to the left to display the All menus screen.
2. On the All menus screen, select **EV > Next Departure Time**.

3. Set the anticipated departure schedule.

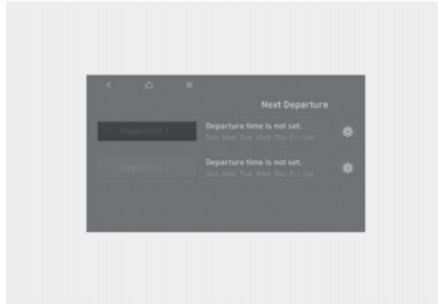

4. Set anticipated time the vehicle will depart after charging.

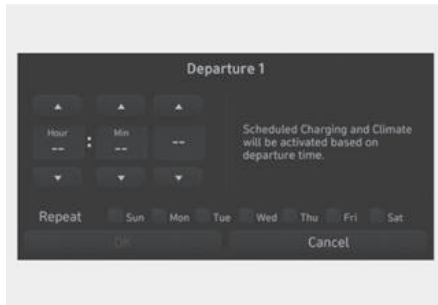

5. At **Repeat** option, select the day of the week to activate scheduled charging and target temperature for the departure time.

### Setting Scheduled Charging and Climate

You can set the date and time of when to charge the battery and the climate control temperature. Also, you may select the time to start charging using the off-peak time setting.

#### **i** Information

- Scheduled charging and climate can be activated based on the departure time.
- To use scheduled charging and climate function, the vehicle must be connected to the charger at the scheduled time.
- The scheduled climate function directly uses the power of the connected charger. It can maintain a pleasant environment and enhance vehicle performance by controlling the temperature of the vehicle and the battery without using the high voltage battery power.

### ***Setting scheduled charging***

Follow the instructions below to set the off-peak time and scheduled charging option.

1. On the infotainment system, swipe the Home screen to the left to display the All menus screen.
2. On the All menus screen, **EV > Scheduled Charging and Climate > Scheduled Charging**.
3. Set the off-peak hours at **Start Time** and **End Time**.

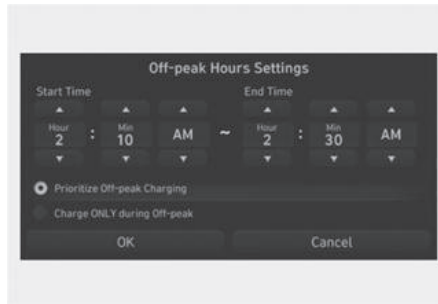

4. Select the charging option.
  - **Prioritize Off-peak Charging:** Charging is activated during the off-peak time. It may keep on charging past off-peak time to reach the target battery charge level.
  - **Charge ONLY during Off-peak:** Charging is activated only during the off-peak time. It may not be able to reach the target battery charge level.
  - For more information about setting the target battery charge level, refer to the “Setting the target battery charge level” section in this chapter.

### Setting a scheduled climate

Follow the instructions below to set the scheduled climate control temperature.

1. On the infotainment system, swipe the Home screen to the left to display the All menus screen.
2. On the All menus screen, select **EV > Scheduled Charging and Climate > Scheduled Charging**.
3. Set the desired temperature.
  - The air conditioning system is activated at the departure time.
  - For more information about setting the departure time, refer to the “Setting the Next Departure Time” section in this chapter.

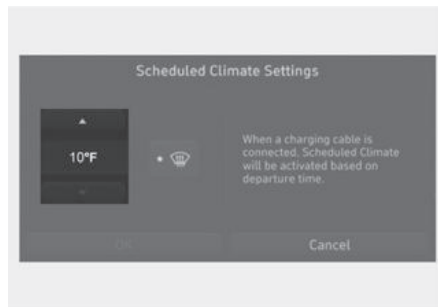

### Setting a Battery Discharging Limit When Using Vehicle to Load (V2L)

Setting battery discharging limit (%) can prevent the battery from discharging when operating home appliances or electronic devices using the high voltage battery.

- For more information about V2L function, refer to the “Setting the Next Departure Time” section in this chapter.

#### **i** Information

V2L is the system provides AC power using the high voltage battery for driving to operate several electronic devices. You can operate home appliances and electronic devices, or charge another electric vehicle in emergency using the charged electricity from the vehicle's battery while camping or doing other outdoor activities.

---

1. On the infotainment system, swipe the Home screen to the left to display the All menus screen.
2. On the All menus screen, select **EV > Electricity Use**.
3. Set the desired battery discharging limit (%).
  - The battery discharging limit can only be set below the current high voltage battery level.
  - When the high voltage battery level reaches the set battery discharging limit, V2L function automatically cuts off electrical supply.



## Setting Electric Vehicle Specialized Functions

You can set various EV specialized functions such as target battery charge level, charging current, battery conditioning mode, and utility mode from the **EV Settings** screen.

### **Setting the target battery charge level**

Follow the instructions below to set the target battery charge level when charged with an AC charger or a DC charger.

1. On the infotainment system, swipe the Home screen to the left to display the All menus screen.
2. On the All menus screen, select **EV > EV Settings > Max. % Charge**.

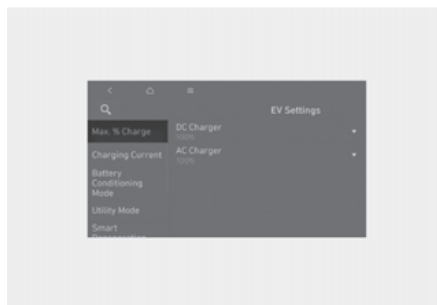

3. Set each of the target battery charge level for AC charging and DC charging.
  - The charging level can be changed by 10 %.
  - If the target battery charge level is lower than the current high voltage battery charge level, the battery will not be charged.

### Setting the charging current

Follow the instructions below to set the charging current when using an AC charger or a portable charger.

1. On the infotainment system, swipe the Home screen to the left to display the All menus screen.
2. On the All menus screen, select **EV** > **⚙️ (EV Settings)** > **Charging Current**
  - If the charging stops before reaching the target battery charge level while charging with an AC charger or a portable charger, reduce the size of the input current and retry charging.
  - The charging time may differ depending on which charging current is selected.

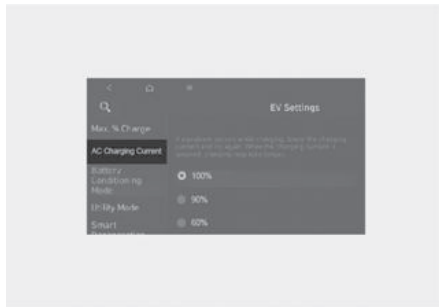

### Setting battery conditioning mode

You can raise the battery temperature to maintain optimal driving performance and DC charging performance at conditions when the low temperature of the high voltage battery temperature may degrade the battery performance.

1. On the infotainment system, swipe the Home screen to the left to display the All menus screen.
2. On the All menus screen, select **EV** > **⚙️ (EV Settings)** and select **Battery Conditioning Mode**.
  - The battery temperature while driving will be maintained adequately.

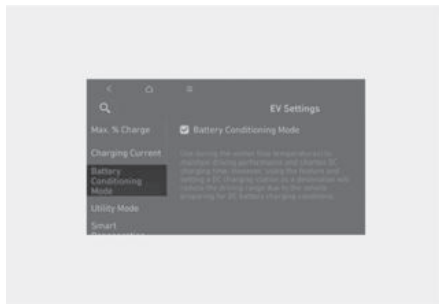



## *i* Information

Be aware of the followings when using battery conditioning mode.

- The driving distance may be reduced as energy is required to increase the battery temperature.
- If the battery temperature is low during driving or when the scheduled air conditioner/heater is activated, the battery conditioning mode is operated to improve driving performance. To ensure driving distance the battery conditioning mode will not be operated when the battery level is too low.
- If you set the DC charging station as your destination while using the battery conditioning mode, the battery temperature is optimized for charging and you can shorten the charging time after you arrive and start charging.
- Battery conditioning mode is available for vehicles equipped with the battery heater.

### **Setting Utility Mode**

Utility mode allows the high voltage battery to be used instead of the 12 V auxiliary battery for purposes other than driving. You can use the audio and lights of the vehicle without discharging the 12 V auxiliary battery and even use the indoor V2L feature.

## *i* Information

- You cannot drive the vehicle while the utility mode is activated, and the gear can only be shifted to P (Park).
- You can use every electric device in the vehicle while the utility mode is activated.
- When the utility mode is activated, the Electronic Parking Brake (EPB) is applied automatically.

Follow the instructions below to set the utility mode.

1. Check the operation conditions of the utility mode.
  - The **READY** (ready indicator) is displayed on the instrument cluster.
  - The gear is shifted to P (Park).
2. On the infotainment system, swipe the Home screen to the left to display the All menus screen.
3. On the All menus screen, select **EV** > **EV Settings** > **Utility mode** and select **Activate Utility mode** to activate the function (Utility Mode: ON).

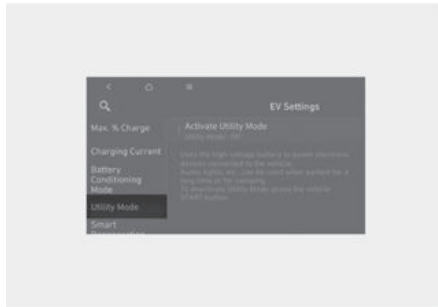

- The **READY** (ready indicator) turns off and the **UTIL** (utility indicator) illuminates on the instrument cluster and the EPB is applied.
- The utility mode can be deactivated by pressing the Start/Stop button to the OFF position.
- If you want to utilize V2L function in the vehicle while the utility mode is activated, refer to the “Using Electricity Inside the Vehicle” section in this chapter.

### **i** Information

If the utility mode is not activated when the vehicle is in the ready (**READY**) mode and the gear is shifted to P (Park), inspect the operation status of EPB.

---

### **Searching for nearby charging stations**

Around the course, around the current site, around the selected destination or charging stations of interest can be searched. If you choose the charging station, the detailed information is provided.

### **i** Information

- When you sign up HYUNDAI BlueLink service, the available chargers at each charging station are displayed.
- 

1. On the infotainment system, swipe the Home screen to the left to display the All menus screen.
2. On the All menus screen, select **EV** and select the charging station icon next to the vehicle

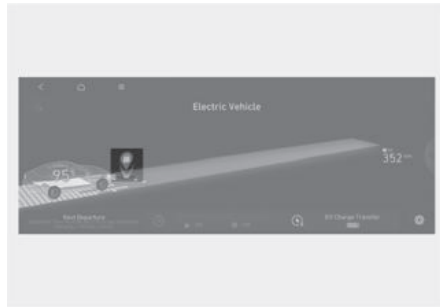

3. Choose a searching option from the list on the left side of the screen.

- You can choose among **Along Route**, **Near My Location**, **Near Destination**, **Near Center of Map** and **Favorite Station**.
- The direction (arrow) and distance, charger type, address, and location on the map of the charging stations corresponding to the selected option are displayed on the right side of the screen.



4. Select the charging station on the list and check the detailed information.

## Using V2L Function

Using the Vehicle to Load (V2L) feature, you can turn on electronic devices by connecting them to the high voltage battery.

### Safety Precautions When Using the V2L Function

Before using the V2L function, read and comply with all the safety information below. Failure to do so may cause electric shock or fire and result in serious injury, death, vehicle malfunction, or property damage.

#### *Precautions when using the V2L function*

##### **WARNING**

- Do not use the V2L function if the V2L connector, charging inlet, power plug, or cable is damaged, corroded, or rusted.
- Do not touch the V2L connector, charging inlet, or power plug with wet hands.
- Do not use the V2L function if the connection part of the V2L connector and the charging inlet is loose.
- Check if there is no water, dust, or other contaminants before connecting the connector and the power plug. They may cause electric shock or fire.
- Do not put metal objects or touch the V2L connector or charging inlet with bare hands.
- For electric devices used outdoors in a vehicle, use a product that is waterproof or use it in a waterproof environment. If rain or humidity intrude into electric devices, multi-outlets, extension cords, etc., it may cause electric shock or damage the vehicle or devices.
- If there is a risk of lightning, do not use the V2L function outside the vehicle.
- Do not use electric heating appliances such as an electric kettle, toaster, or iron in the vehicle. Doing so may result in a fire and injury.

#### *Precautions when the cooling fan operates*

##### **WARNING**



When using the V2L, the cooling fan in the vehicle motor compartment can operate automatically even if the vehicle is turned off. Do not put your hand near the cooling fan when the V2L is operating.

---

## ***Precautions for handling and using the V2L connector***

### **CAUTION**

- Do not modify or disassemble the V2L connector. It may cause fire, electric shock, or injury. Damage to your vehicle caused by modification and disassembling is not covered by warranty.
  - Be careful when connecting or disconnecting the power plug to the V2L connector or when opening or closing the V2L connector cover. You may scratch your hand.
  - Be sure to disconnect the V2L connector from the vehicle when you are finished using V2L.
  - Do not charge the vehicle using the V2L connector. If you charge the vehicle arbitrarily by remodeling the power cable of the connector, etc., it may damage the vehicle.
  - Do not place objects on the V2L connector. It may damage the cable and cause electric shock or fire.
  - Do not drop the V2L connector or apply any impact on it. Keep it clean in a dry place without water or humidity.
- 

### **NOTICE**

- Be sure to disconnect the V2L connector from the vehicle when you are finished using the V2L function.
  - Do not charge the vehicle using the V2L connector. If you charge the vehicle by modifying the power cable of the connector, etc., it may damage the vehicle.
- 

## ***Precautions when using electric/electronic products***

### **CAUTION**

- Before using the product, check the precautions and how to use the product referring to the product manual.
- Only use products that have obtained national safety certification.
- Only use an electric device that does not exceed the maximum power capacity that the vehicle can supply. However, some of the electric devices may not operate normally even if the product has power consumption less than the maximum power capacity provided by the vehicle.
  - Electric devices that require high power during initial operation.
  - Measuring devices that need to process accurate data.
  - Electric devices that are sensitive to inverter type AC charger.
- Do not use products that require a continuous power supply, such as medical equipment. The power supply may be interrupted depending on the vehicle's condition.
- The V2L discharging mode is blocked automatically in the event of overheating. When the discharging mode is blocked, check whether the V2L connector or power plug is contaminated, worn, corroded or broken.

- If the temperature falls to a proper level after it is left unattended, you can use it again.
  - If overheating repeats when using a certain electric device, do not use the electric device.
  - Do not connect more than two extension cords or multi-outlet. Also, when using the extension cable, ensure that the cable is not twisted. Heat from the overlapped cable may cause fire.
  - Do not hang home appliances on the wire.
  - Do not use if the sheath of home appliance cables is damaged or broken.
  - Fully insert the power plug when connecting it to the power.
  - Only use qualified power plug with ground connection that meets the standard. Do not use worn, corroded, or broken power plug or improper power plug that does not meet the standard.
- 

### Using Electricity Outside the Vehicle

Before using V2L function, carefully read all the safety information and precautions on the “Safety Precautions When Using the V2L Function” section and follow the instructions.

Follow the instructions below to connect the V2L connector to the charging inlet on the vehicle and supply power to an electronic product.

1. Open the cover of the V2L connector.
2. Close the cover after connecting the plug of an electronic product to the power outlet of the connector.

#### **WARNING**

Some types of plugs may not fit into the outlet cover of the V2L connector, causing incomplete closing of the cover. Do not use the V2L connector on a rainy or snowy day if the outlet cover is not completely closed. There is a risk of fire and/or injury.

---

3. Open the connection terminal protection cap of the connector with the open switch pressed.
4. Open the charging door and connect the V2L connector to the charging inlet on the vehicle.
  - Connect the V2L connector to the charging inlet within 60 seconds after opening the charging door.
  - Time remaining until the battery level reaches the set value, and the distance to empty at the set value appears on the instrument cluster or the infotainment system.
5. Press the power switch of the V2L connector.

- The power is supplied and the indicator on the V2L connector is turned on.

### **i** Information

- When the V2L connector is connected to the charging inlet of the vehicle, all doors and connectors will be automatically locked to prevent theft and separation. To disconnect the V2L connector, unlock the door and pull the connector with the open switch pressed.
- Before using the V2L function, deactivate the scheduled climate setting referring to the “Setting Scheduled Charging and Climate”. The V2L function may be cut off depending on the scheduled climate setting.
- To check and change the V2L setting, refer to the “Setting a Battery Discharging Limit When Using Vehicle to Load (V2L)”.
- If an electric device that exceeds the maximum power capacity is connected, a warning message appears on the instrument cluster and the power supply shuts off immediately.

## Using Electricity Inside the Vehicle

You can connect home appliances or electric devices to the power outlet inside the vehicle.

### **!** WARNING

Do not use an electric heating appliances like electric kettle, toaster, or iron in the vehicle. It may cause a fire or injury.

1. Press the Start/Stop button to the ON position or activate the utility mode.
  - For more information about the utility mode, refer to the “Setting Utility Mode” section in this chapter.
2. Use the smart key to unlock the power outlet cover.





3. Open the power outlet cover by sliding it to the left, and connect the power plug of the electric device to the power socket.
- Time remaining until the battery level reaches the set value, and the distance to empty at the set value appears on the instrument cluster or the infotainment system.

**i Information**

- The indicator on the power outlet indicates the operation status.



Indicator Status	Description
Blue	Standby
Red	The power outlet is connected but no power is supplied.
Green	The power outlet is connected, and the power is supplied normally.

- V2L discharging mode shuts off if the vehicle turns off while using indoor V2L when the vehicle is ON.
- Opening the charging door or connecting the V2L connector to the charging inlet, the V2L discharging mode shuts off.
- If you want to use the indoor and outdoor V2L simultaneously, first connect the V2L connector to the charging inlet and then use the indoor V2L.



- When the high voltage battery charge level reaches the set discharging limit (%), the operation stops, and a warning message appears on the instrument cluster. If you want V2L operation, set the discharging limit (%) lower than the current battery charge.
  - For more information about the discharging limit, refer to the “Setting a Battery Discharging Limit When Using Vehicle to Load (V2L)” section in this chapter.
  - For more information about warnings, refer to the “Checking the warning and indicator lights” section in this chapter.

## Solving V2L Problems

If a problem occurs while using the V2L function, the V2L stops and a related messages appears on the instrument cluster.

Check the cause of the message and take an appropriate measure referring to the table below.

Message	Cause	Measure
V2L finished. Defined charge level reached	The high voltage battery level reaches the discharging limit set level.	To use the V2L continuously, make the discharging limit set level lower than the present battery level. (For more information, refer to the “Setting a Battery Discharging Limit When Using Vehicle to Load (V2L)”.)
Energy consumption too high. V2L cancelled	An electrical appliance that exceeds the maximum power output the vehicle can supply is connected.	Check the total power consumption of the electrical appliance and replace it a product within the V2L maximum power output.
V2L conditions not met	V2L is stopped for the following reasons: <ul style="list-style-type: none"> <li>• V2L connector switch off</li> <li>• V2L connector overheating</li> <li>• Opening the charging door while using the V2L indoor outlet</li> </ul>	Make sure there are no problems with the V2L connector and the vehicle indoor outlet.

## Aux. Battery Saver+

The Aux. Battery Saver+ is a function that monitors the charging status of the 12 V battery. If the 12 V battery level is low, the main high voltage battery charges the 12 V battery.

### **i** Information

- The Aux. Battery Saver+ activates maximum of 20 minutes. If the Aux. Battery Saver+ function activates more than 10 times consecutively, in the Automatic Mode the function will stop activating, judging that there is a problem with the auxiliary battery. In this case, drive the vehicle for some period of time. The function will start activating if the auxiliary battery returns to normal.
  - The Aux. Battery Saver+ function cannot prevent battery discharge if the auxiliary battery is damaged, worn out, used as a power supply or unauthorized electronic devices are used.
  - If the Aux. Battery Saver+ function was activated the high voltage battery level may have decreased.
- 

### **⚠** WARNING

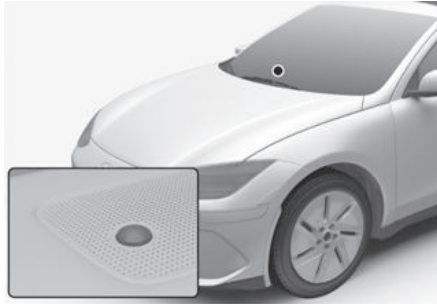

When the function is activating, the indicator lamp illuminates and high voltage electricity flows into the vehicle. Do not touch the high voltage electric wire (orange), connector, and all electric components and devices. This may cause electric shock and lead to injuries. Also, do not modify your vehicle in any way. This may affect your vehicle performance and lead to an accident.

---

## Driving Your Electric Vehicle

Check how to use the devices inside the vehicle that you must know for driving, such as starting, braking, and shifting the electric vehicle.

### Starting and Stopping the Vehicle

Follow the instructions below to start or stop the vehicle.

#### CAUTION

- Always fasten the seat belt before starting the vehicle for safety.
- Check if the EBP is applied before starting the vehicle.

#### **Starting the vehicle**

1. Holding the smart key, sit in the driver's seat.
2. Press the Start/Stop button while pressing the brake pedal.
  - On the instrument cluster, **READY**(ready indicator) is displayed.

#### Information

While the **READY** (ready indicator) is displayed, press the brake pedal, shift to D (Drive) or R (Reverse), and release the EBP and the brake pedal to start moving the vehicle forward or backward. You can start driving by pressing the accelerator pedal slowly and decelerate or stop by pressing the brake pedal.

#### **Stopping the vehicle**

1. Stop the vehicle completely by pressing the brake pedal.
2. Apply the EPB while pressing the brake pedal, and press the gear's P button to shift to P (Park).
3. Press the Start/Stop button.
  - The **READY** (ready indicator) on the instrument cluster turns off.

#### Information

There are other Start/Stop button positions besides the ON/OFF. Use it appropriately paying attention to the discharging of the 12 V battery.

- **ACC:** The 12 V battery power is turned on, allowing some devices, such as infotainment system and air conditioning system to operate. Press the Start/Stop button when it is in the OFF position to turn on ACC.
- **ON:** The 12 V battery power is turned on, allowing to check the instrument cluster and use all the electric devices inside the vehicle. Press the Start/Stop button when it is in the ACC position to turn it ON.

### **Understanding virtual engine sound system**

Electric vehicles do not use an internal combustion engine, so there is no engine noise while driving. The Virtual Engine Sound System (VESS) generates engine sound to make pedestrians aware of the approaching vehicle when driving.

- If the vehicle is in the ready (**READY**) mode and the gear is not in P (Park), the VESS is operated.
- When the gear is shifted to R (Reverse), an additional warning sound will be heard.

#### **⚠ CAUTION**

- Be aware that the vehicle does not make engine noise while driving.
  - Pay attention to the surrounding environment and drive carefully.
  - After parking or waiting for a traffic light, please check around for children, or other obstacles before departure.
  - When reversing, check directly behind you before driving. Pedestrians may not be able to recognize vehicle sounds.
- 

### **Checking Electric Vehicle Driving Information**

During vehicle operation, the instrument cluster displays the main information, such as distance to empty, real-time energy status, battery charge level, and warning messages, via the user interface and indicators.

#### **Factors affecting the distance to empty**

The distance to empty refers to the distance that can be driven by the current charged battery level and is displayed on the bottom of the instrument cluster while driving the electric vehicle.



The distance to empty vary depending on many factors such as driving habits, power usage, driving conditions, and high voltage battery. The distance to empty may be increased or decreased from the certified figures as it reflects all the factors comprehensively. Check the distance to empty considering the following:

- The driving habits: The driving speed and tendency of accelerating and decelerating. High speed driving or frequent accelerating and decelerating reduces the distance to empty.

- The power usage: Additional power use, such as the air conditioner, heater, lights, etc. As the power usage increases, the distance to empty reduces.
- The driving conditions: The weather, temperature, and terrain. If you drive in snow/rain/strong wind or low temperature, the distance to empty will be reduced. The distance to empty will also be reduced when driving uphill or on slippery or rough roads.
- The high voltage battery energy: Proportional to the State of Charge (SOC), but may vary depending on the battery temperature and the State of Health (SOH) of a battery.

### ***Change in the distance to empty when 100 % charged***

In case the distance to empty has been reduced due to learning of the driving habit or the driving conditions, you can increase the distance to empty again by continuously driving following the “Tips for enhancing the distance to empty”.

- Resetting the previously learned driving patterns at the service center may increase the distance to empty displayed on the bottom of the instrument cluster, but it does not increase the actual distance to empty. The distance to empty may not be accurate until the learning proceeds.
- If the high voltage battery temperature is low in winter, the distance to empty reduces but it is not a permanent change. The distance to empty will increase again once the temperature rises.
- If you reduce the power usage, the distance to empty will increase.
- Natural degradation may occur with the high voltage battery depending on the number of years the vehicle is used. This may reduce the distance to empty.

### ***When setting a destination***

When the destination is set, the distance to empty may change because the distance to empty is recalculated using the information of the destination instead of the learned electric energy economy history.

#### ***i* Information**

The distance to empty may vary significantly based on traffic conditions or driving speed.

---

### ***Tips for enhancing the distance to empty***

The distance to empty vary depending on the charge level of the high voltage battery, weather, temperature, duration of the battery use, terrain, driving habits, etc.

You can increase the distance to empty by driving the vehicle following the instructions below.

- The air resistance increases rapidly as the electric vehicle drives faster, so avoid speeding to increase the distance to empty and the electric energy economy.
- Rapid acceleration consumes a lot of driving energy and rapid deceleration limits the regenerative braking. Gradually depress and release the accelerator pedal when accelerating or decelerating to maintain speed.
- If you operate the air conditioner or heater too much, the high voltage battery uses excessive electricity. This may reduce the distance to empty. Therefore, set the cabin temperature to 72 °F (22 °C) AUTO level 2. Various assessment tests have been used to verify that this setting maintains optimal energy consumption rates. Especially in winter, reducing heating and using heated seats instead can significantly increase the distance to empty. Turn off the air conditioner or heater if you do not need them.
- When using the air conditioner or heater, the energy consumption is reduced if recirculation mode is selected instead of fresh mode. Fresh mode requires a large amount of energy consumption as the outside air has to be reheated or cooled.
- Close the windows while driving. Driving with the windows open increases air resistance and the usage of the air conditioner or heater.
- When using the air conditioner or heater while driving alone, use the DRIVER ONLY function.
- Always maintain specified tire pressures and use tires for electric vehicles.
- Do not use unnecessary electrical components while driving.
- Do not load unnecessary items in the vehicle.
- Do not mount parts that may increase air resistance.

### ***When the distance to empty is insufficient***

- When the High voltage battery level warning light is displayed, immediately charge the vehicle at a nearby charging station.
- Drive energy efficiently following the “Tips for enhancing the distance to empty.”
- When the battery level is 0 %, do not try to drive. Move to a safe place and call for help.

### ***Checking the real time energy status (CHARGE/POWER gauge)***

The CHARGE/POWER gauge displays the charging and discharging status of the electric energy produced by the regenerative braking and the energy consumption of the electric motor.



- **CHARGE:** Shows the charging status of the electric motor when vehicle is decelerating or driving on a downhill road (being charged by the regenerative brakes). The more electric energy is charged, the lower the gauge level.
- **POWER:** Shows discharging status of the electric motor when vehicle is accelerating or driving on an uphill road. The more electric energy is discharged (used), the higher the gauge level.

### ***Checking the State of Charge (SOC)***

The SOC indicator is displayed at the bottom of the CHARGE/POWER gauge and shows the charge level of the high voltage battery as a percentage. The lower the number, the more the vehicle needs to be charged, and 100 % indicates a full charge.

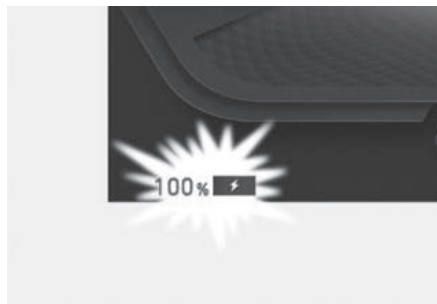

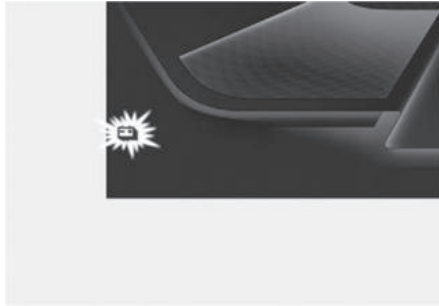

- When the remaining battery of the high voltage battery is lower than 10 %, the warning light will be displayed.
- When the warning light is displayed, charge the vehicle.

### **i** Information

- To find a nearby charging station, refer to the “Searching for nearby charging stations” in this chapter.
- Check if the SOC is enough before driving on highways.
- After the warning light is displayed, immediately charge the vehicle at a nearby charging station. The vehicle may not operate properly depending on the driving speed, weather, and other driving conditions.

---

### ***Checking the warning and indicator lights***

The warning and indicator lights are displayed in the middle of the instrument cluster before or while driving, depending on the status of the electric vehicle. Understand the meaning of the warning and indicator lights referring to the instructions below and drive safely.

### **⚠ CAUTION**





If the warning light illuminates while driving or does not go off, have the vehicle inspected by an authorized HYUNDAI dealer.

---



## Checking the warning lights

Check the cause of the warning lights referring to the table below and take appropriate measures.

Warning Light	Cause	Measure
<p><b>Service warning light</b></p> 	<p>This warning light illuminates:</p> <ul style="list-style-type: none"> <li>• When there is a problem with related parts of the electric vehicle control system, such as sensors, etc.</li> <li>• When an actuator, electric compressor for air conditioning, etc. malfunctions.</li> </ul>	<p>In a normal condition, it illuminates for about 3 seconds when the Start/Stop button is in the ON position and then goes off.</p> <ul style="list-style-type: none"> <li>• When the warning light illuminates while driving, or does not go off after starting the vehicle, have your vehicle inspected by an authorized HYUNDAI dealer.</li> </ul>
<p><b>Powerdown indicator light</b></p> 	<p>This warning light illuminates:</p> <ul style="list-style-type: none"> <li>• When the high voltage battery level is too low or voltage is decreasing. (Output limit occurs when the charge level is insufficient.)</li> <li>• When the temperature of the high voltage battery is too high or too low.</li> <li>• When the driving system temperature is overheated and requires protection.</li> </ul>	<p>If it illuminates alone, it is not failure.</p> <ul style="list-style-type: none"> <li>• If both Power down indicator light and Service warning light illuminate at the same time, have the vehicle inspected by an authorized HYUNDAI dealer.</li> <li>• When the indicator is illuminating, immediately charge the vehicle. The driving speed may be limited and the vehicle may not properly drive uphill.</li> </ul>
<p><b>High voltage battery level warning light</b></p> 	<p>This warning light illuminates when the high voltage battery level is low.</p>	<p>Immediately charge the vehicle. The vehicle can drive an additional 18-31 mi. (30-50 km).</p> <ul style="list-style-type: none"> <li>• The actual distance to empty depends on the driving conditions.</li> </ul>
<p><b>Regenerative brake warning light</b></p>  	<p>This warning light illuminates when the regenerative brake does not operate and the brake does not perform well due to the malfunction of the brake system.</p>	<p>Drive safely and have your vehicle inspected by an authorized HYUNDAI dealer.</p> <ul style="list-style-type: none"> <li>• The operation of the brake pedal may feel deeper than normal or the braking distance may increase.</li> </ul>

### Checking the indicator lights

Check the meaning of the indicator lights referring to the table below and take appropriate measures if necessary.

Indicator Light	Meaning
<b>Charging connector indicator light</b> 	Indicates the charging connector is connected to the high voltage battery. <ul style="list-style-type: none"><li>• When the charging connector is connected, it turns green.</li></ul>
<b>Ready indicator light</b> <b>READY</b>	Illuminates when the electric vehicle is ready to be driven, and indicates that the vehicle is operable. <ul style="list-style-type: none"><li>• When the vehicle malfunctions, the indicator goes off or blinks.</li><li>• If the indicator is turned off or blinks, have the vehicle inspected and repaired by an authorized HYUNDAI dealer.</li></ul>

### Checking warning messages

Check the meaning of the warning messages referring to the table below and take appropriate measures.

#### WARNING

- Do not drive with a warning message displayed.
- If a warning message does not go off after taking measures, have the vehicle immediately inspected and repaired by an authorized HYUNDAI dealer.

Warning Message	Cause	Measure
<b>Low EV battery</b>	<p>The high voltage battery level reaches below 20 %.</p> <ul style="list-style-type: none"> <li>• The warning light on the instrument cluster turns on simultaneously.</li> </ul>	Charge the vehicle immediately.
<b>Charge immediately. Power limited</b>	<p>The high voltage battery level reaches below 10 %.</p> <ul style="list-style-type: none"> <li>• The warning light on the instrument cluster turns on simultaneously.</li> <li>• The vehicle's power may be reduced to minimize the energy consumption of the high voltage battery.</li> </ul>	Charge the battery immediately.
<b>Check electric vehicle system</b>	There is a problem with the electric vehicle control system.	<ul style="list-style-type: none"> <li>• Do not drive when the warning message is displayed.</li> <li>• Have the vehicle inspected by an authorized HYUNDAI dealer.</li> </ul>

Warning Message	Cause	Measure
<p><b>Power limited</b></p>	<p>This warning message is displayed when the power of the vehicle is limited to ensure the safety of high-powered components for the reasons below:</p> <ul style="list-style-type: none"> <li>• The high voltage battery level is too low or voltage is decreasing.</li> <li>• The temperature of the high voltage battery is too high or too low.</li> <li>• When the driving system is overheated and requires protection.</li> </ul>	<p>If it illuminates alone, it did not fail.</p> <ul style="list-style-type: none"> <li>• Charge the vehicle if the charge level is low.</li> <li>• If both Power down indicator light and Service warning light illuminate at the same time, have the vehicle inspected by an authorized HYUNDAI dealer.</li> <li>• Do not accelerate or start the vehicle suddenly when the warning message is displayed.</li> <li>• Be careful when the Power down indicator light is displayed. The vehicle may not properly drive uphill and roll back on a slope.</li> </ul>
<p><b>Low EV battery temperature. Power limited</b></p>	<p>If you start or turn off the vehicle when the outside temperature is low, both warning messages appear to protect electric vehicle system.</p> <ul style="list-style-type: none"> <li>• If the high voltage battery charge level is low and parked outside for a long time, vehicle power could be limited due to the low battery temperature.</li> </ul>	<ul style="list-style-type: none"> <li>• Charging the battery before driving helps increase power.</li> <li>• If these warning messages are still displayed even after the ambient temperature has increased, have the vehicle inspected and repaired by an authorized HYUNDAI dealer.</li> </ul>
<p><b>EV Battery Overheated! Stop vehicle</b></p>	<p>The high voltage battery temperature is too high.</p>	<ul style="list-style-type: none"> <li>• Stop the vehicle in a safe place and turn off the Start/Stop button and wait until the battery temperature decreases.</li> <li>• If these warning messages are still displayed even after turning off the engine and waiting for a sufficient time, immediately have the vehicle inspected by an authorized HYUNDAI dealer.</li> </ul>
<p><b>Stop vehicle and check power supply</b></p>	<p>A failure occurs in the power supply system.</p>	<p>Immediately stop the vehicle in a safe place. Have the vehicle towed to an authorized HYUNDAI dealer for inspection and maintenance.</p>

Warning Message	Cause	Measure
<b>Unplug vehicle to start</b>	You have started the vehicle with the charging connector plugged in.	Unplug the charging cable and start the vehicle.
<b>Charging Door Open</b>	You have started the vehicle with the charging door opened.	Check if the charging door is completely closed after charging the vehicle.
<b>Charging Stopped. Check the AC charger</b>	<p>These warning messages are displayed when charging is stopped for the reasons below:</p> <ul style="list-style-type: none"> <li>• There is a problem with the external AC charger or DC charger.</li> <li>• The external AC charger stopped the charging.</li> <li>• The charging cable is damaged.</li> </ul>	<ul style="list-style-type: none"> <li>• Check whether there is any problem with the external AC or DC charger and charging cable.</li> <li>• Charge the vehicle with an AC charger that has been approved for proper operation or a genuine HYUNDAI portable charger.</li> <li>• If the same problem occurs, have the vehicle inspected by an authorized HYUNDAI dealer.</li> </ul>
<b>Charging Stopped. Check the cable connection</b>	<p>These warning messages are displayed when charging is stopped for the reasons below:</p> <ul style="list-style-type: none"> <li>• The charging connector is not correctly connected to the charging inlet.</li> <li>• The unlock button on the charging connector is pressed.</li> </ul>	<ul style="list-style-type: none"> <li>• Separate the charging connector from the vehicle and reconnect it.</li> <li>• Check whether there is any problem, such as external damage, foreign substances, etc., with the charging connector and charging inlet.</li> <li>• Charge the vehicle with a charger that has been approved for proper operation or a genuine HYUNDAI portable charger.</li> <li>• If the same problem occurs, have the vehicle inspected by an authorized HYUNDAI dealer.</li> </ul>

## Countermeasures for Accidents or Fire

When an accident occurs while driving the electric vehicle, turn on the hazard warning flasher, move the vehicle to a safe place, and do not let other people approach the site.

### WARNING

When an accident occurs, and the high voltage battery is damaged, harmful gas and electrolytes may leak.

- Be careful not to touch the leaked liquid.
  - When you suspect leakage of inflammable gas and other harmful gases, open the windows and immediately evacuate to a safe location.
  - If any leaked fluid comes in contact with your eyes or skin, immediately clean the affected area thoroughly with tap water or saline solution and have doctors inspect it as soon as possible.
- 

## If the Electric Vehicle Catches Fire

If a fire occurs, evacuate to a safe place and do not let other people approach the site.

- Contact the fire department, report an electric vehicle fire, and then follow its instructions.

### CAUTION

- If a fire occurs, evacuate to a safe place and wait until the firefighters arrive.
  - If the lower part of the vehicle where the high voltage battery is located catches fire, large amount of water must be supplied continuously for a long time to completely extinguish the fire. It is hard to extinguish the fire without sufficient water and appropriate fire extinguishers. If you approach the vehicle carelessly, it may cause accidents, such as electric shock, and result in serious injury.
- 

## If the Electric Vehicle Is Submerged

If the electric vehicle is submerged while driving, follow the instructions below:

- Immediately turn off the vehicle and evacuate to a safe place with your key.
- Contact the emergency rescue service such as a fire department, or an authorized HYUNDAI dealer.

### WARNING

Never touch the submerged electric vehicle. This may lead to an accident such as an electric shock or fire.

---

## If the Electric Vehicle Needs Towing

If towing is required, lift all wheels to tow. Towing with the wheels on the ground may damage the vehicle's motor components.

### CAUTION

Contact the fire department when towing the vehicle after a fire. When a vehicle fire occurs due to the battery, there is a risk of a second fire.

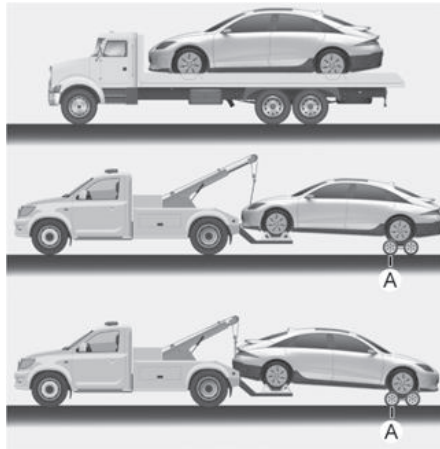

[A] Dollies

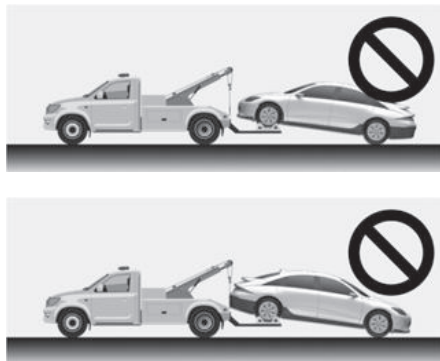

## Other Precautions for Electric Vehicle Accidents

### CAUTION

- Be extremely cautious for electricity safety. An electric shock accident may occur due to a short circuit in high voltage power.
  - When you paint or apply heat treatment to the vehicle as a result of an accident, the performance of the high voltage battery can be reduced. If heat treatment is required, contact an authorized HYUNDAI dealer.
  - Use or install only genuine parts. Third-party parts or modified parts may damage the electric power system
-



# 2. Vehicle Information, Consumer Information, and Reporting Safety Defects

- Exterior Overview (Front View)..... 2-2
- Exterior Overview (Rear View)..... 2-3
- Interior Overview ..... 2-4
- Center Console Overview ..... 2-5
- Steering Wheel Control Overview ..... 2-7
- Motor Compartment Overview ..... 2-8
- Dimensions ..... 2-9
- Electric Vehicle Specifications ..... 2-9
- Bulb Wattage ..... 2-10
- Tires and Wheels..... 2-11
- Air Conditioning System ..... 2-12
- Vehicle Weight and Luggage Volume..... 2-12
- Available Front Trunk Weight ..... 2-12
- Recommended Lubricants and Capacities ..... 2-13
- Vehicle Identification Number (VIN)..... 2-14
- Vehicle Certification Label..... 2-14
- Tire Specification and Pressure Label..... 2-14
- Motor Number ..... 2-15
- Air Conditioner Compressor Label..... 2-15
- Refrigerant Label ..... 2-15
- Consumer Information..... 2-16
- Reporting Safety Defects..... 2-17
- Open Source Software Notice ..... 2-18

## Exterior Overview (Front View)

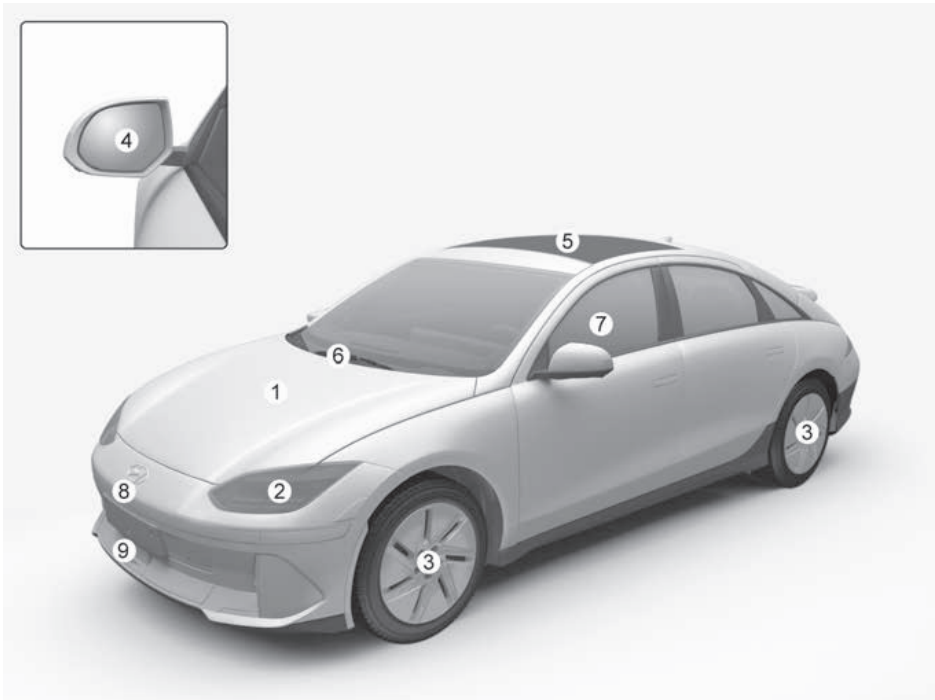

The actual shape may differ from the illustration.

(1) Hood .....	5-56
(2) Headlight .....	9-47
(3) Tires and wheels .....	9-23
(4) Side view mirror .....	5-46
(5) Wide sunroof .....	5-53
(6) Front windshield wiper blades .....	9-17
(7) Window .....	5-49
(8) Wide-front view camera .....	7-131
(9) Front radar .....	7-4

## Exterior Overview (Rear View)

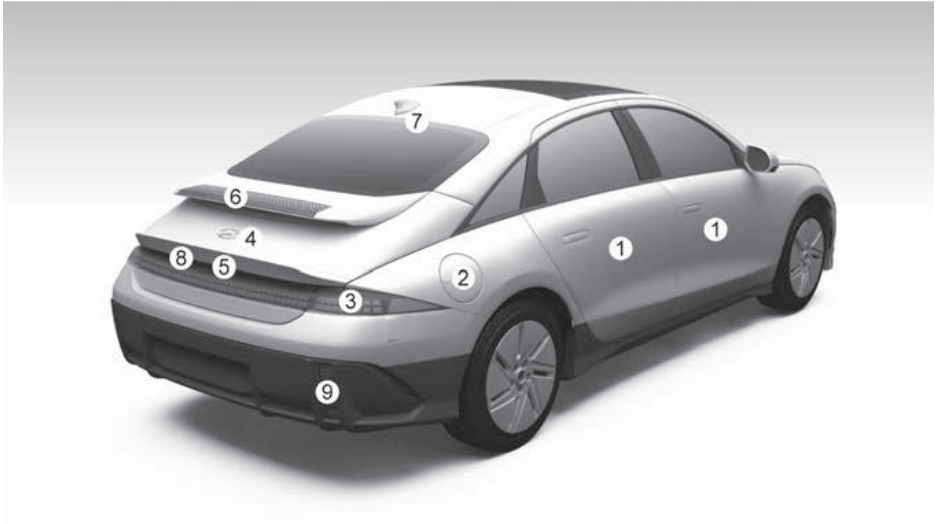

The actual shape may differ from the illustration.

(1) Door .....	5-21
(2) Electric charging door .....	5-65
(3) Rear combination light .....	9-48
(4) Trunk .....	5-58
(5) Trunk open/close button .....	5-60
(6) High mounted stop light .....	9-48
(7) Antenna .....	5-113
(8) Wide-rear view camera .....	7-104
(9) Reverse light .....	9-48

## Interior Overview

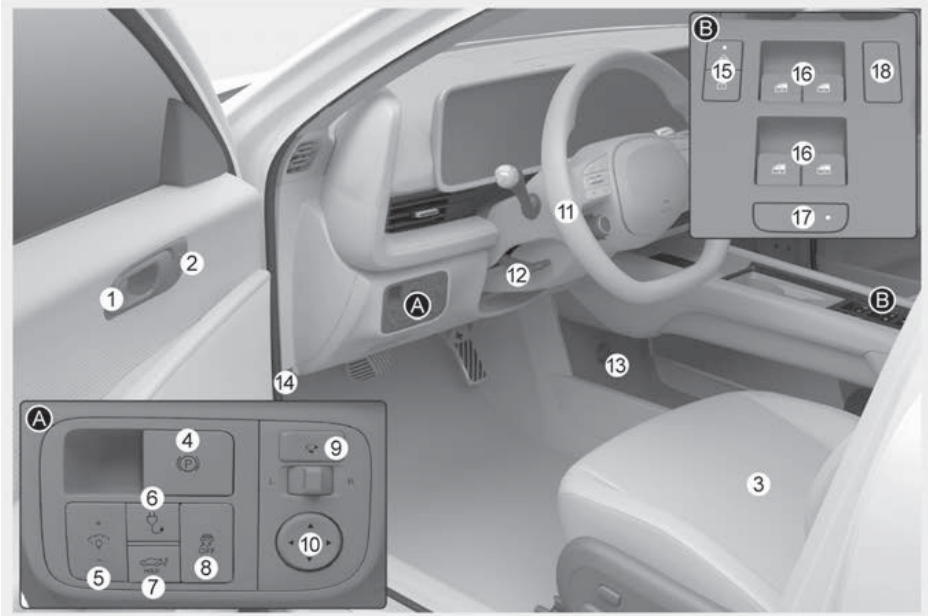

The actual shape may differ from the illustration.

(1) Inside door handle .....	5-26
(2) Integrated memory system .....	5-31
(3) Seat .....	3-3
(4) EPB (Electronic Parking Brake) switch .....	6-24
(5) Instrument panel illumination .....	4-3
(6) Charging door open/close button .....	5-65
(7) Power trunk open/close button .....	5-59
(8) ESC (Electronic Stability Control) OFF button .....	6-32
(9) Side view mirror folding button .....	5-46
(10) Side view mirror control switch .....	5-46
(11) Steering wheel .....	5-34
(12) Steering wheel tilt/telescopic lever .....	5-34
(13) Power outlet .....	5-108
(14) Hood release lever .....	5-56
(15) Central door lock switch .....	5-26
(16) Power window switches .....	5-49
(17) Power window lock button .....	5-50
(18) AUTO Hold button .....	6-28

## Center Console Overview

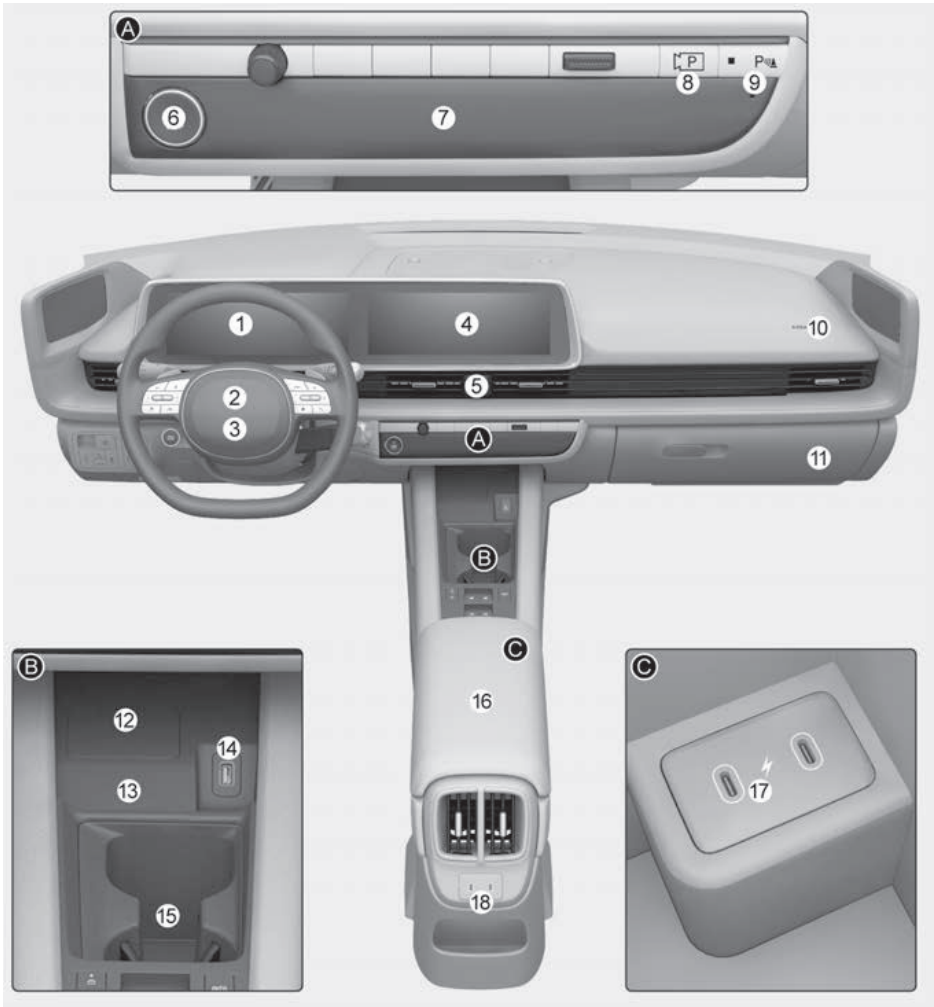

The actual shape may differ from the illustration.

(1) Instrument cluster .....	4-2
(2) Horn .....	5-35
(3) Driver's front airbag .....	3-41
(4) Infotainment system .....	4-27
(5) Hazard warning flasher button .....	8-2
(6) Start/Stop button .....	6-4
(7) Automatic climate control system .....	5-84

(8) Parking/View button .....7-104, 7-107, 7-139  
(9) Parking Safety button.....7-121, 7-126, 7-131, 7-139  
(10) Passenger's front airbag ..... 3-41  
(11) Glove box ..... 5-106  
(12) Wireless charging system pad ..... 5-109  
(13) Wireless charging system ..... 5-109  
(14) USB port ..... 5-113  
(15) Cup holder..... 5-106  
(16) Center console..... 5-105  
(17) USB charger ..... 5-108  
(18) Rear seat USB charger ..... 5-108

## Steering Wheel Control Overview

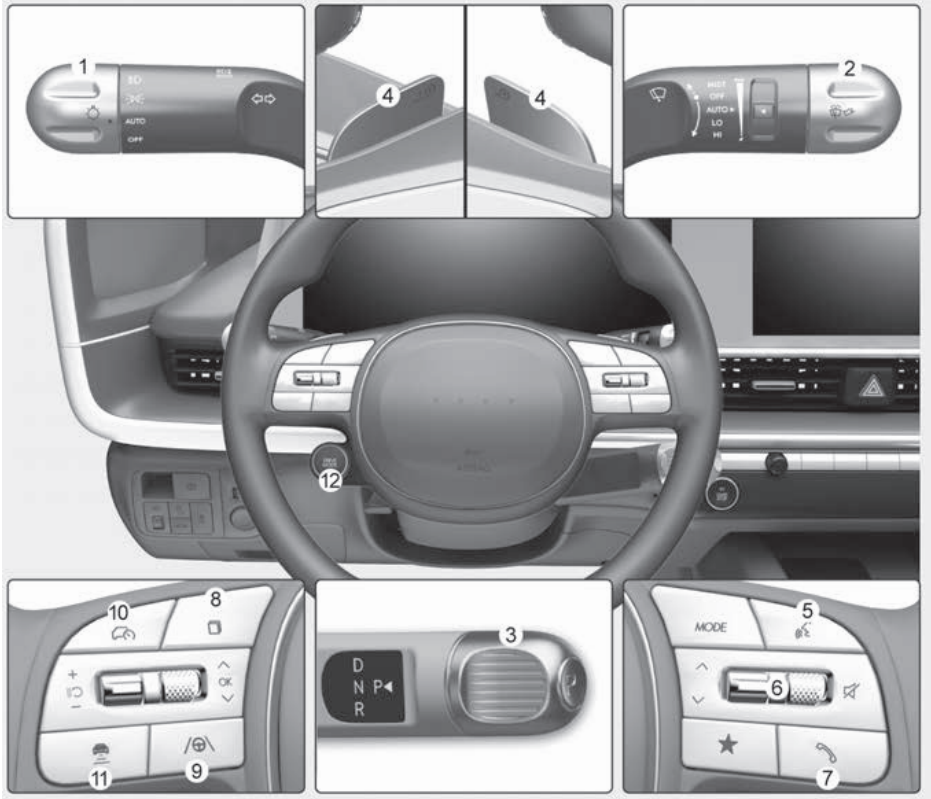

The actual shape may differ from the illustration.

(1) Lighting control lever .....	5-71
(2) Wiper and washer control lever.....	5-81
(3) Rotary shifter(Rotary gearshift dial).....	6-8
(4) Paddle shifter .....	6-14
(5) Voice recognition button .....	5-115
(6) Steering wheel audio controls.....	5-113
(7) Bluetooth® wireless technology hands-free button .....	5-115
(8) Cluster display control .....	4-24
(9) Lane Driving Assist button .....	7-30, 7-89
(10)Driving Assist button .....	7-70
(11) Vehicle Distance button.....	7-67
(12)Drive mode button .....	6-42

## Motor Compartment Overview

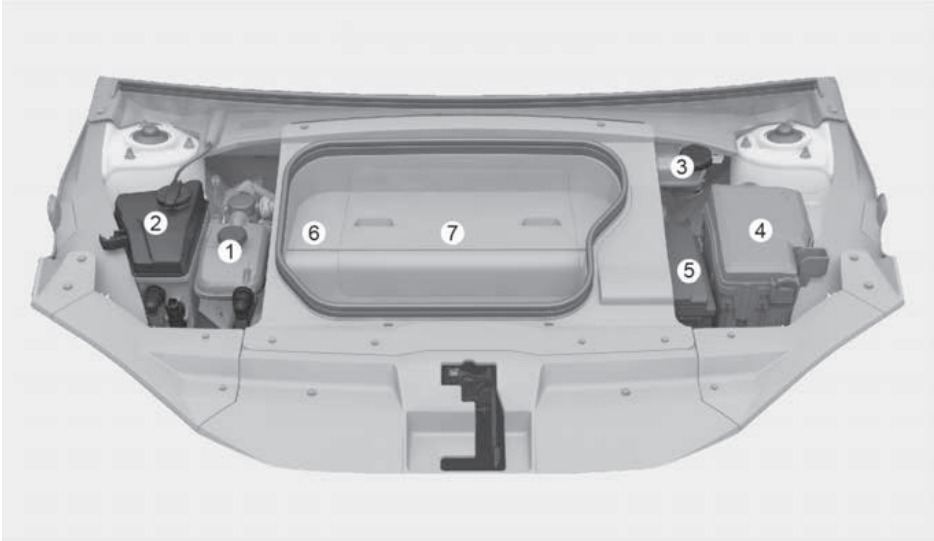

The actual motor compartment in the vehicle may differ from the illustration.

(1) Coolant reservoir .....	9-13
(2) Windshield washer fluid reservoir .....	9-16
(3) Brake fluid reservoir .....	9-14
(4) Fuse box .....	9-35
(5) Battery (12 V) .....	9-19
(6) Front trunk .....	5-57
(7) Cabin air filter.....	9-16



## Dimensions

Items		in. (mm)	
Overall length		191.14 (4,855)	
Overall width		74.02 (1,880)	
Overall height		58.86 (1,495)	
Tread	Tire size	Front	Rear
	18 in.	64.37 (1,635)	64.72 (1,644)
	20 in.	64.17 (1,630)	64.53 (1,639)
Wheelbase		116.14 (2,950)	

## Electric Vehicle Specifications

Items		Standard type	Extended type	
		2WD	2WD	AWD
Motor	Max. output (kW)	111.4	168.1	73.9+165.4
	Max. torque (Nm)	350	350	255 + 350
Battery (Lithium-ion)	Capacity (kWh)	53	77.4	77.4
	Power output (kW)	173	277	277
	Voltage (V)	480	697	697
Charger (On-Board Battery Chargers)	Max. output (kW)	10.9	10.9	10.9

## Bulb Wattage

Light Bulb		Bulb Type	Wattage
Front	Headlight	Low	LED
		High	LED
	Turn signal light		LED
	Parking light		LED
	Daytime Running light (DRL)		LED
	Side marker		LED
	Front trunk light		LED
	Side repeater light		LED
Rear	Stop light		LED
	Tail light		LED
	Turn signal light		LED
	Reverse light		LED
	Side marker		LED
	License plate light		LED
	High mounted stop light		LED
Interior	Front seat map and room lamp		LED
	Rear seat room lamp		LED
	Vanity mirror lamp		LED
	Glove box lamp		LED
	Door mood lamp		LED
	Luggage compartment lamp		LED

## Tires and Wheels

Items	Tire Size	Wheel Size	Battery Type	Inflation Pressure psi (kPa)				Wheel Lug Nut Torque lbf-ft (kgf-m, N-m)
				Normal Load		Maximum Load		
				Front	Rear	Front	Rear	
Full Size Tire	225/55R18	7.5J X 18	2WD Standard	38 (260)	38 (260)	38 (260)	38 (260)	79-94 (11-13, 108-127)
	225/55R18	7.5J X 18	2WD Extended	38 (260)	38 (260)	38 (260)	38 (260)	
	225/55R18	7.5J X 18	AWD Extended	36 (250)	36 (250)	36 (250)	36 (250)	
	245/40R20	8.5J X 20	2WD Extended	36 (250)	37 (255)	36 (250)	37 (255)	
	245/40R20	8.5J X 20	AWD Extended	36 (250)	37 (255)	36 (250)	37 (255)	

### NOTICE

- It is permissible to add 3 psi (20 kPa) to the standard tire pressure specification if colder temperatures are expected soon. Tires typically lose 1 psi (7 kPa) for every 12 °F (7 °C) temperature drop. If extreme temperature variations are expected, recheck your tire pressure as necessary to keep them properly inflated.
- Tire inflation pressures may vary depending on changes in elevation. If driving in areas of higher or lower elevation, be sure to check and adjust for proper tire inflation.
- Do not exceed the maximum inflation pressure, as found on the sidewall of the tire(s).

### CAUTION

When replacing tires, ALWAYS use the same size, type, brand, construction and tread pattern supplied with the vehicle. If not, it can damage the related parts or make it work irregularly.

## Air Conditioning System

Item		Weight of Volume	Classification
Refrigerant	With heat pump	32±0.9 oz. (900±25 g)	R-1234yf
	Without heat pump	25±0.9 oz. (700±25 g)	
Compressor lubricant	With heat pump	6.11±0.35 oz. (190±10 g)	POE
	Without heat pump	5.29±0.35 oz. (150±10 g)	

Contact an authorized HYUNDAI dealer for more information.

## Vehicle Weight and Luggage Volume

Gross Vehicle Weight		Luggage Volume
Standard Type	Extended Type	
2WD: 4,894 lbs. (2220 kg)	2WD: 5,313 lbs. (2410 kg) AWD: 5,556 lbs. (2520 kg)	14.2 cu.ft (401 ℓ)

## Available Front Trunk Weight

2WD / AWD
25 lbs. (10 kg)

## Recommended Lubricants and Capacities

To help achieve proper vehicle performance and durability, use only lubricants of the proper quality.

These lubricants and fluids are recommended for use in your vehicle.

Lubricant			Volume	Classification	
Gear fluid	2WD	Rear	3.6-3.7 US qt. (3.4-3.5 ℓ)	HK ATF 65 SP4M-1	
		AWD	3.4-3.5 US qt. (3.2-3.3 ℓ)		
	Rear	3.6-3.7 US qt. (3.4-3.5 ℓ)			
Coolant	Standard type	with heat pump	2WD	Mixture of antifreeze and water (Phosphate-based Ethylene glycol coolant Battery for aluminum radiator)	
			AWD		18.74 US qt. (17.73 ℓ)
		without heat pump	2WD		17.85 US qt. (16.89 ℓ)
			AWD		18.20 US qt. (17.22 ℓ)
	Extended type	with heat pump	2WD		20.63 US qt. (19.52 ℓ)
			AWD		20.90 US qt. (19.78 ℓ)
		without heat pump	2WD		19.96 US qt. (18.89 ℓ)
			AWD		20.36 US qt. (19.27 ℓ)
Brake fluid			about 24 oz. (700 cc)	SAE J1704 DOT-4 LV, FMVSS 116 DOT-4, ISO 4925 CLASS-6	

## Vehicle Identification Number (VIN)

Frame number

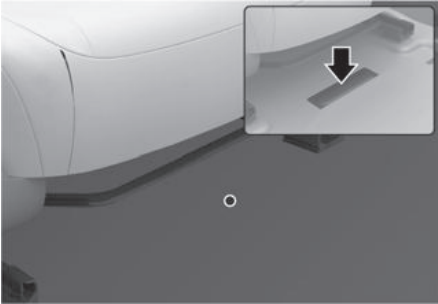

The vehicle identification number (VIN) is the number used in registering your vehicle and in all legal matters pertaining to its ownership, etc.

The number is punched on the floor under the right front seat. To check the number, open the cover.

VIN label (if equipped)

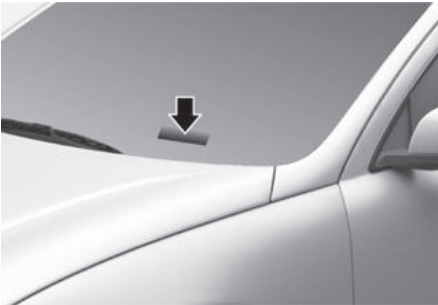

The VIN is also on a plate attached to the top of the left side dashboard. The number on the plate can easily be seen through the windshield from outside.

## Vehicle Certification Label



The vehicle certification label attached on the driver's (or front passenger's) side center pillar gives the vehicle identification number (VIN).

## Tire Specification and Pressure Label



The tires supplied on your new vehicle are chosen to provide the best performance for normal driving.

The tire label located on the driver's side center pillar gives the tire pressures recommended for your vehicle.

## Motor Number

2WD/AWD

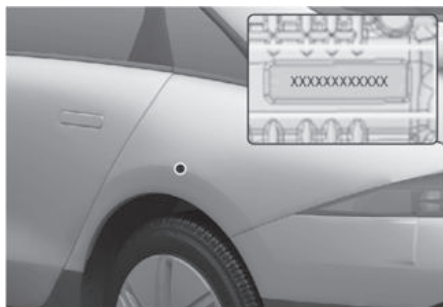

AWD

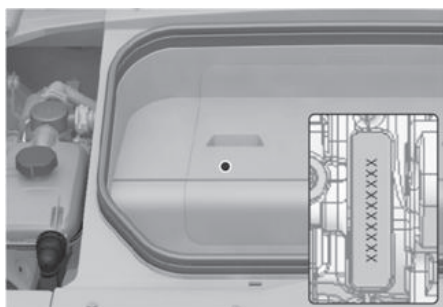

The motor numbers can be checked at the bottom of the vehicle.

## Air Conditioner Compressor Label

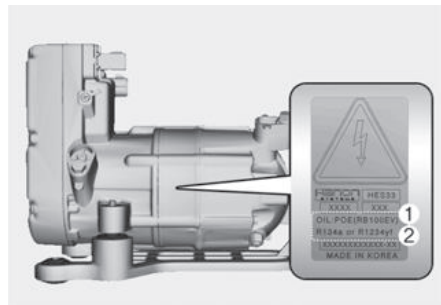

A compressor label informs you the type of compressor your vehicle is equipped with such as model, supplier part number, production number, refrigerant oil (1) and refrigerant (2).

## Refrigerant Label



The refrigerant label provides information such as refrigerant type and amount. (R-1234yf)

## Consumer Information

This consumer information has been prepared in accordance with regulations issued by the National Highway Traffic Safety Administration of the U.S. Department of Transportation. Your HYUNDAI dealer will help answer any questions you may have as you read this information.

HYUNDAI motor vehicles are designed and manufactured to meet or exceed all applicable safety standards.

For your safety, however, we strongly urge you to read and follow all directions in this Owner's Manual, particularly the information under the headings "NOTICE", "CAUTION" and "WARNING".

If, after reading this manual, you have any questions regarding the operation of your vehicle, please contact the Hyundai Customer Care Center.

Hyundai Customer Care

P.O. Box 20850

Fountain Valley, CA 92728

800-633-5151

[consumeraffairs@hmausa.com](mailto:consumeraffairs@hmausa.com)

Hyundai's Customer Care representatives are available Monday through Friday, between the hours of 6:00 AM and 5:00 PM PST and Saturday between 6:30 AM and 3:00 PM PST (English).

For Customer Care assistance in Spanish or Korean, representatives are available Monday through Friday between 6:30 AM and 3:00 PM PST.



## Reporting Safety Defects

If you believe that your vehicle has a defect which could cause a crash or could cause injury or death, you should immediately inform the National Highway Traffic Safety Administration (NHTSA) in addition to notifying HYUNDAI MOTOR AMERICA.

To contact NHTSA, you may call the Vehicle Safety Hotline toll-free at 1-888-327-4236 (TTY: 1-800-424-9153);

go to <http://www.safercar.gov>;

download the SaferCar mobile application;

or write to:

Administrator, NHTSA  
1200 New Jersey Ave, SE, West Building  
Washington, D.C. 20590.

You can also obtain other information about motor vehicle safety from <http://www.safercar.gov>.

If NHTSA receives similar complaints, it may open an investigation, and if it finds that a safety defect exists in a group of vehicles, it may order a recall and remedy campaign. However, NHTSA cannot become involved in individual problems between you, your dealer, or HYUNDAI MOTOR AMERICA.

## Open Source Software Notice

This vehicle contains software with open source licenses. Open source software information including the source code, copyright notices and referred license terms may be obtained on the website

<https://www.hyundai.com/worldwide/opensource>

HYUNDAI Motor Company will provide the open source code to you in storage medium such as CD-ROM for minimum charge covering the cost of performing source distribution upon email request to [opensource@hyundai.com](mailto:opensource@hyundai.com) within a period of 3 years from the date of product purchase.

# 3. Seats & Safety System

- Important Safety Precautions..... 3-2
  - Always Wear Your Seat Belt ..... 3-2
  - Restrain All Children ..... 3-2
  - Airbag Hazards ..... 3-2
  - Driver Distraction..... 3-2
  - Control Your Speed..... 3-2
  - Keep Your Vehicle In Safe Condition..... 3-2
- Seats ..... 3-3
  - Safety Precautions ..... 3-6
  - Front Seats..... 3-6
  - Rear Seats..... 3-10
  - Head Restraint ..... 3-12
  - Seat Warmers..... 3-16
  - Air Ventilation Seats..... 3-19
- Seat Belts ..... 3-20
  - Seat Belt Safety Precautions..... 3-20
  - Seat Belt Warning Light ..... 3-21
  - Seat Belt Restraint System..... 3-23
  - Additional Seat Belt Safety Precautions..... 3-28
  - Care of Seat Belts..... 3-30
- Child Restraint System (CRS) ..... 3-30
  - Children Always in the Rear ..... 3-30
  - Selecting a Child Restraint System (CRS) ..... 3-31
  - Installing a Child Restraint System (CRS) ..... 3-33
- Airbag - Supplemental Restraint System..... 3-39
  - Where are the Airbags? ..... 3-41
  - How does the Airbags System Operate?..... 3-44
  - What to Expect After an Airbag Inflates ..... 3-47
  - Occupant Classification System (OCS) ..... 3-47
  - Why didn't My Airbag Go Off in a Collision? ..... 3-53
  - SRS Care ..... 3-57
  - Additional Safety Precautions..... 3-58
  - Airbag Warning Labels..... 3-58

## Important Safety Precautions

You will find many safety precautions and recommendations throughout this section, and throughout this manual. The safety precautions in this section are among the most important.

### Always Wear Your Seat Belt

A seat belt is your best protection in all types of accidents. Airbags are designed to supplement seat belts, not to replace them. So even though your vehicle is equipped with airbags, always make sure you and your passengers wear your seat belts, and wear them properly.

### Restrain All Children

All children under age 13 should ride in your vehicle properly restrained in a rear seat, not the front seat. Infants and small children should be restrained in an appropriate child restraint system. Larger children should use a booster seat with the lap/shoulder belt until they can use the seat belt properly without a booster seat.

### Airbag Hazards

While airbags can save lives, they can also cause serious or fatal injuries to occupants who sit too close to them, or who are not properly restrained. Infants, young children, and short adults are at the greatest risk of being injured by an inflating airbag. Follow all instructions and warnings in this manual.

### Driver Distraction

Driver distraction presents a serious and potentially deadly danger, especially for inexperienced drivers. Safety should be the primary concern when behind the wheel and drivers need to be aware of the

wide array of potential distractions, such as drowsiness, reaching for objects, eating, personal grooming, other passengers, and using mobile phones.

Drivers can become distracted when they take their eyes and attention off the road or their hands off the wheel to focus on activities other than driving. To reduce your risk of distraction and an accident:

- Set up your mobile devices (for example, mp3 players, phones, navigation units, etc.) only when your vehicle is parked or safely stopped.
- Only use your mobile device when allowed by laws and conditions permit safe use. Never text or email while driving. Most countries have laws prohibiting drivers from texting. Some countries and cities also prohibit drivers from using handheld phones.
- Never let the use of a mobile device distract you from driving. You have a responsibility to your passengers and others on the road to always drive safely with your hands on the wheel as well as your eyes and attention on the road.

### Control Your Speed

Excessive speed is a major factor in crash injuries and deaths. Generally, the higher the speed the greater the risk, but serious injuries can also occur at lower speeds. Never drive faster than is safe for current conditions regardless of the maximum speed posted.

### Keep Your Vehicle In Safe Condition

Having a tire blowout or a mechanical failure can be extremely hazardous. To reduce the possibility of such problems, check your tire pressures and condition frequently and perform all regularly scheduled maintenance.

## Seats

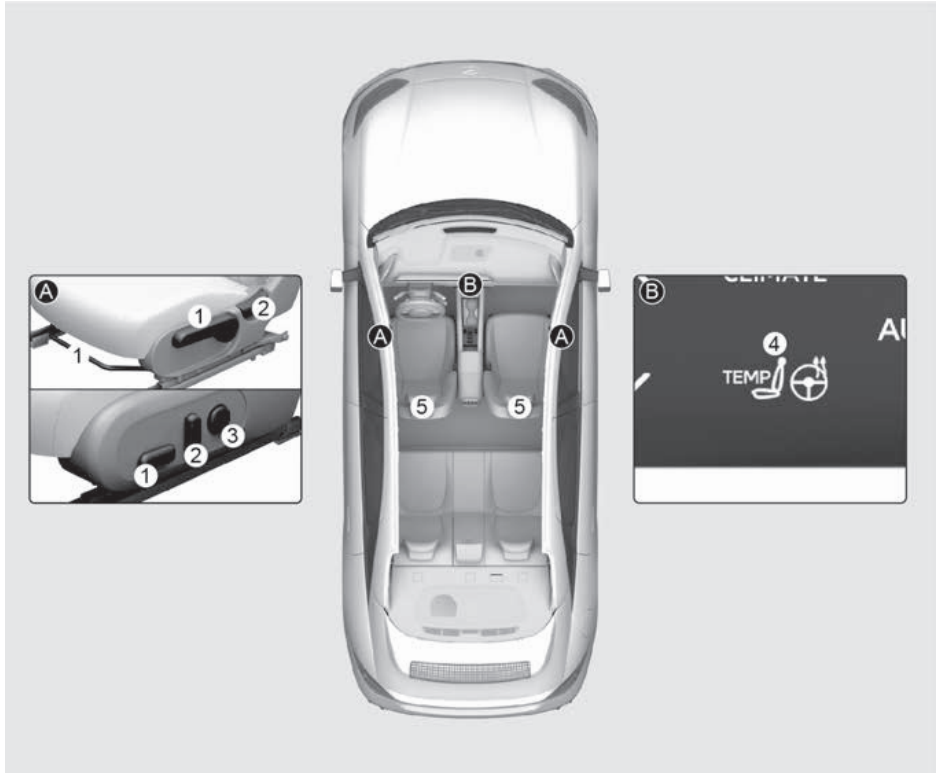

The actual shape may differ from the illustration.

### **Front seat**

- (1) Front seat sliding forward or rearward/Cushion height/Seat cushion angle
- (2) Front seatback angle
- (3) Front seat lumbar support
- (4) Front seat warmer/Air ventilation seat
- (5) Front head restraints

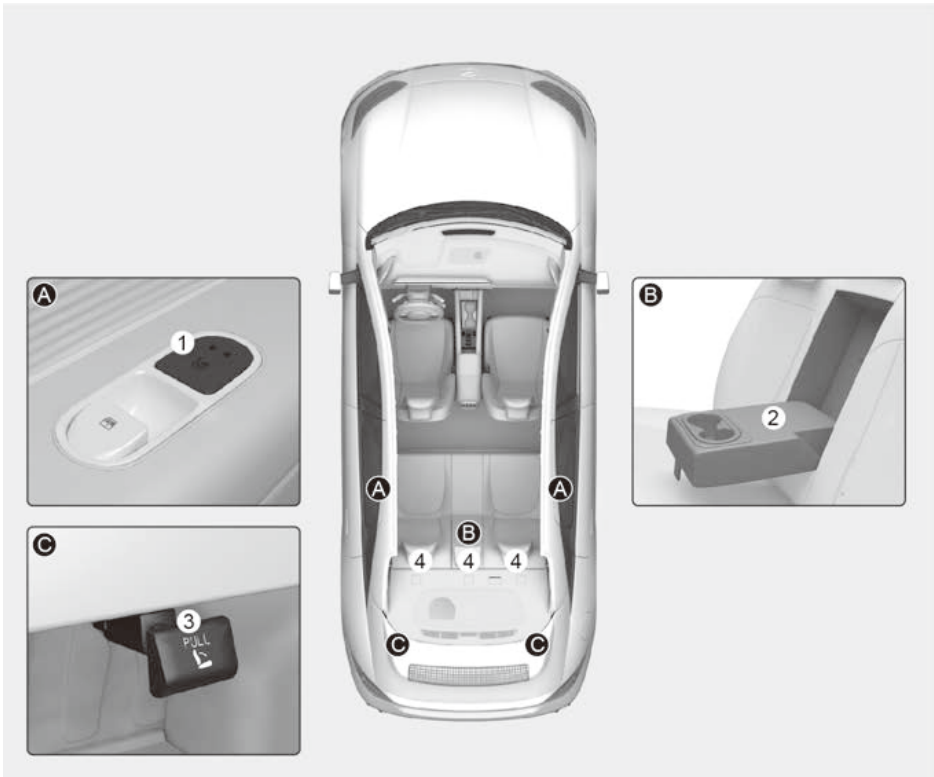

The actual shape may differ from the illustration.

**Rear seat**

- (1) Rear seat warmer
- (2) Rear armrest
- (3) Rear seatback folding lever
- (4) Rear head restraints

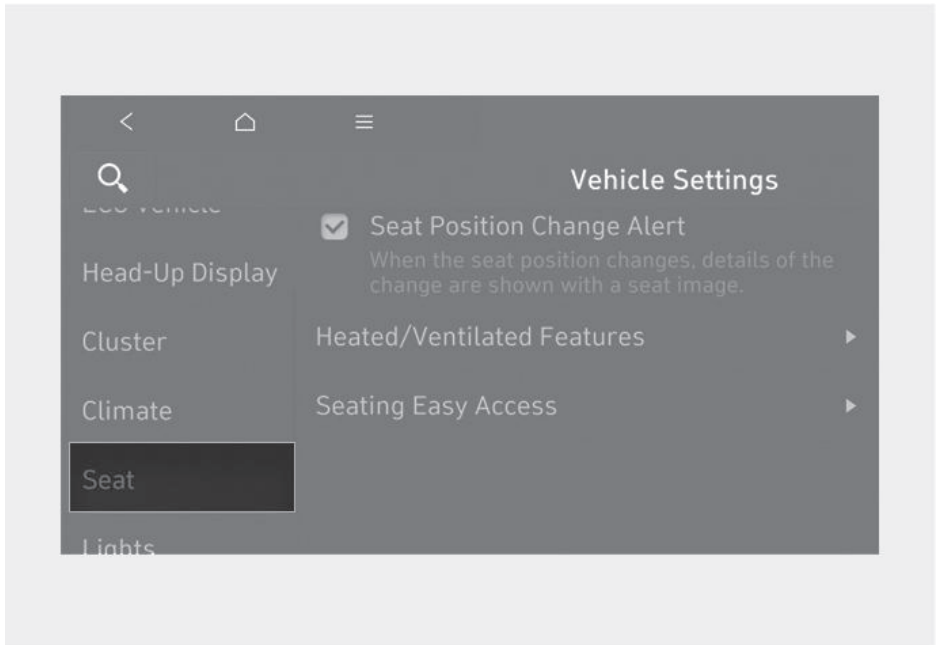

### **Infotainment system**

Select **Setup > Vehicle > Seat** from the Settings menu in the infotainment system, you may use various convenience functions.

- Seat Position Change Alert: When the seat position changes, details of the change are shown with a seat image.
- Heated/Ventilated Features
  - Auto. Controls That Use Climate Control Settings (for driver's seat): The seat temperature is automatically controlled.
- Seating Easy Access
  - Driver Seat Easy Access: The distance (Normal/Extended/Off) the seat automatically moves when the driver enters or leaves the vehicle may be selected.

### ***i* Information**

- The information provided may differ depending on which functions are applicable to your vehicle.
- The infotainment system may change after software updates. For more information, refer to the user's manual provided in the infotainment system and the quick reference guide.

## Safety Precautions

Adjusting the seats so that you are sitting in a safe and comfortable position plays an important role for the safety of the driver and passengers as much as seat belts and airbags when in an accident.

### WARNING

Do not use a cushion that reduces friction between the seat and the passenger. The passenger's hips may slide under the lap portion of the seat belt during an accident or a sudden stop.

Serious or fatal internal injuries could result because the seat belt cannot operate properly.

---

## Airbags

You can take steps to reduce the risk of being injured by an inflating airbag. Sitting too close to an airbag greatly increases the risk of injury in the event the airbag inflates. Move your seat as far back as possible from front airbags while still maintaining control of the vehicle.

### WARNING

To reduce the risk of serious injury or death from an inflating airbag, take the following precautions:

- Adjust the driver's seat as far to the rear as possible while maintaining the ability to control the vehicle.
  - Adjust the front passenger seat as far to the rear as possible.
  - Hold the steering wheel by the rim with your hands at the 9 o'clock and 3 o'clock positions to minimize the risk of injuries to your hands and arms.
  - NEVER place anything or anyone between you and the airbag.
  - Do not allow the front passenger to place feet or legs on the dashboard to minimize the risk of leg injuries.
- 

## Seat belts

Always fasten your seat belt before starting any trip. At all times, passengers should sit upright and be properly restrained. Infants and small children must be restrained in appropriate Child Restraint Systems. Children who have outgrown a booster seat and adults must be restrained using the seat belts.

### WARNING

Take the following precautions when adjusting your seat belt:

- NEVER use one seat belt for more than one occupant.
  - Always position the seatback upright with the lap portion of the seat belt snug and low across the hips.
  - NEVER allow children or small infants, or pets to ride on a passenger's lap.
  - Do not route the seat belt across your neck, across sharp edges, or reroute the shoulder strap away from your body.
  - Do not allow the seat belt to become caught or jammed.
- 

## Front Seats

### WARNING

Take the following precautions when adjusting your seat:

- NEVER attempt to adjust the seat while the vehicle is moving. The seat could respond with unexpected movement and may cause loss of vehicle control resulting in an accident.
- Do not place anything under the front seats. Loose objects in the driver's foot area could interfere with the operation of the foot pedals, causing an accident.
- Do not allow anything to interfere with the normal position and proper locking of the seatback.



- Do not place a cigarette lighter on the floor or seat. When you operate the seat, gas may exit out of the lighter causing a fire.
- Use extreme caution when picking up small objects trapped under the seats or between the seat and the center console. Your hands might be cut or injured by the sharp edges of the seat mechanism.
- If there are occupants in the rear seats, be careful while adjusting the front seat position.
- Make sure that the seat is locked in place after the adjustment. If not, the seat might move unexpectedly resulting in an accident.

### CAUTION

To prevent injury:

- Do not adjust your seat while wearing your seat belt. Moving the seat cushion forward may cause strong pressure on your abdomen.
- Do not allow your hands or fingers to get caught in the seat mechanisms while the seat is moving.

### WARNING

NEVER allow children in the vehicle unattended. The power seats are operable when the vehicle is turned off.

### NOTICE

To prevent damage to the seats:

- Always stop adjusting the seats when the seat has been adjusted as far forward or rearward as possible.
- Do not adjust the seats longer than necessary when the vehicle is turned off. This may result in unnecessary battery drain.
- Do not operate two or more seats at the same time. This may result in an electrical malfunction.

### Manual adjustment

 if equipped

The front seat can be adjusted by using the levers located underneath the seat cushion. Before driving, adjust the seat to the proper position so that you can easily control the steering wheel, foot pedals and controls on the instrument panel.

#### Forward and rearward adjustment



**To move the seat forward or rearward:**

1. Pull up the seat slide adjustment lever and hold it.
2. Slide the seat to the position you desire.
3. Release the lever and make sure the seat is locked in place. Move forward and rearward without using the lever. If the seat moves, it is not locked properly.

### Seatback angle



To recline the seatback:

1. Lean forward slightly and lift up the seatback lever.
2. Carefully lean back on the seat and adjust the seatback to the position you desire.
3. Release the lever and make sure the seatback is locked in place. (The lever **MUST** return to its original position for the seatback to lock.)

### Reclining seatback

Sitting in a reclined position when the vehicle is in motion can be dangerous. Even when buckled up, the protections of your restraint system (seat belts and/or airbags) is greatly reduced by reclining your seatback.

#### **WARNING**

NEVER ride with a reclined seatback when the vehicle is moving.

Riding with a reclined seatback increases your chance of serious or fatal injuries in the event of a collision or sudden stop.

Drivers and passengers should ALWAYS sit well back in their seats, properly belted, and with the seatbacks upright.

Seat belts must be snug against your hips and chest to work properly. When the seatback is reclined, the shoulder belt cannot do its job because it will not be snug against your chest. Instead, it will be in front of you. During an accident, you could be thrown into the seat belt, causing neck or other injuries.

The more the seatback is reclined, the greater chance the passenger's hips will slide under the lap belt or the passenger's neck will strike the shoulder belt.

### Seat height

To change the height of the seat cushion:



- Push down the lever several times, to lower the seat cushion.
- Pull up the lever several times, to raise the seat cushion.

### Power adjustment

 if equipped

The front seat can be adjusted by using the control switches located on the outside of the seat cushion. Before driving, adjust the seat to the proper position so that you can easily control the steering wheel, foot pedals and controls on the instrument panel.

### Forward and rearward adjustment



To move the seat forward or rearward:

1. Push the control switch forward or rearward.
2. Release the switch once the seat reaches the desired position.

### Seat cushion tilt/height adjustment



#### • Seat cushion tilt (1)

To change the angle of the front part of the seat cushion:

Push the front portion of the control switch up to raise or down to lower the front part of the seat cushion.

Release the switch once the seat reaches the desired position.

#### • Seat height (2)

To change the height of the seat cushion: Push the rear portion of the control switch up to raise or down to lower the height of the seat cushion.

Release the switch once the seat reaches the desired position.

### Seatback angle adjustment



To recline the seatback:

1. Push the control switch forward or rearward.
2. Release the switch once the seatback reaches the desired position.

### **Reclining seatback**

Sitting in a reclined position when the vehicle is in motion can be dangerous. Even when buckled up, the protections of your restraint system (seat belts and airbags) is greatly reduced by reclining your seatback.

#### **⚠ WARNING**

NEVER ride with a reclined seatback when the vehicle is moving.

Riding with a reclined seatback increases your chance of serious or fatal injuries in the event of a collision or sudden stop.

Driver and passengers should ALWAYS sit well back in their seats, properly belted, and with the seatbacks upright.

Seat belts must be snug against your hips and chest to work properly. When the seatback is reclined, the shoulder belt cannot do its job because it will not be snug against your chest. Instead, it will be in front of you. During an accident, you could be thrown into the seat belt, causing neck or other injuries.

The more the seatback is reclined, the greater chance the passenger's hips will slide under the lap belt or the passenger's neck will strike the shoulder belt.

### Lumbar support

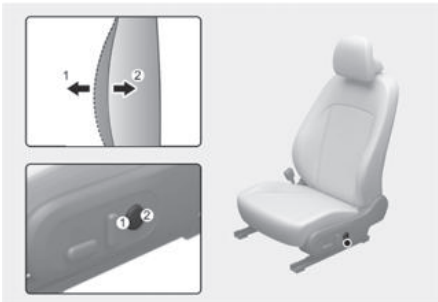

To adjust the lumbar support:

- Press the front portion of the switch (1) to increase support or the rear portion of the switch (2) to decrease support.

### NOTICE

Do not continue to operate the lumbar support when the lumbar support provides its maximum support. Damage to the lumbar support motor could occur.

### Seatback pocket

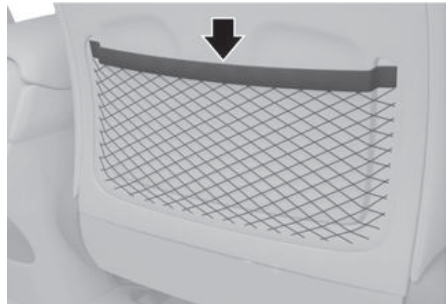

The seatback pocket is provided on the back of the front seatbacks.

### CAUTION

Do not put heavy or sharp objects in the seatback pockets. In an accident they could come loose from the pocket and injure occupants.

## Rear Seats

### WARNING

Take the following precautions:

- Folding the seats
  - Do not fold the seatback when the seat is occupied (for example, passenger, pets or luggage). It may injure the passenger or pet, or damage the luggage.
  - Never allow passengers to sit on top of the folded down seatback while the vehicle is moving. This is not a proper seating position and no seat belts are available for use. This could result in serious injury or death in case of an accident or sudden stop.
  - Objects carried on the folded down seatback should not extend higher than the top of the front seatbacks. This could allow cargo to slide forward and cause injury or damage during sudden stops.

- When returning the rear seatback from a folded to an upright position, hold the seatback and return it slowly. Ensure that the seatback is completely locked into its upright position by pushing on the top of the seatback. In an accident or sudden stop, the unlocked seatback could allow cargo to move forward with great force and enter the passenger compartment, which could result in serious injury or death.
- When folding the seatback, slightly push the seatback or head restraint against the folding direction to control the folding speed. Without the push, the seatback may abruptly fold down and cause injuries when the lever is pulled.
- Loading cargo
  - Make sure the vehicle is off, the gear shifted to P (Park), and the parking brake is securely applied whenever loading or unloading cargo. Failure to take these steps may allow the vehicle to move if the shift button or shift dial is inadvertently pressed or rotated to another position.
  - When cargo is loaded through the rear passenger seats, ensure the cargo is properly secured to prevent it from moving while driving.
- Do not place objects in the rear seats since they cannot be properly secured and may hit vehicle occupants in a collision causing serious injury or death.

### CAUTION

Do not allow your hands or fingers to get caught in the seat mechanisms while adjusting the seats.

### NOTICE

To prevent damage to the vehicle:

- Rear seat belts
  - Before folding the seatback, insert the seat belt buckle in the holder between the seatback and cushion. And insert the seat belt webbing in the guide to prevent the seat belt from being damaged.
- Cargo
  - Be careful when loading cargo through the rear passenger seats to prevent damage to the vehicle interior.

### *Folding the rear seats*

The rear seatbacks can be folded to facilitate carrying long items or to increase the luggage capacity of the vehicle.

To fold down the rear seatback:

1. Set the front seatback to the upright position and if necessary, slide the front seat forward.
2. Lower the rear head restraints to the lowest position.



3. Route the seat belt webbing to the outward of the rear seat to prevent the belts from being trapped behind or under the seats.



4. Fold the seatback toward the front of the vehicle.



5. To use the rear seat, lift and pull the seatback rearward. Pull the seatback firmly until it clicks in to place. Make sure the seatback is locked in place.



### Armrest



The armrest is located in the center of the rear seat. Pull the armrest down from the seatback to use it.

#### CAUTION

The armrest handle may be pressed when folding the rear seatback, but it will be restored after a certain period of time.

### Head Restraint

The vehicle's front and rear seats have adjustable head restraints. The head restraints provide comfort for passengers, but more importantly they are designed to help protect passengers from whiplash and other neck and spinal injuries during an accident, especially in a rear impact collision.

#### WARNING

To help reduce the risk of serious injury or death in an accident, take the following precautions when adjusting your head restraints:

- Always properly adjust the head restraints for all passengers BEFORE starting the vehicle.
- NEVER let anyone ride in a seat with the head restraint removed or reversed.

- Adjust the head restraints so the middle of the head restraint is at the same height as the height of the top of the eyes.

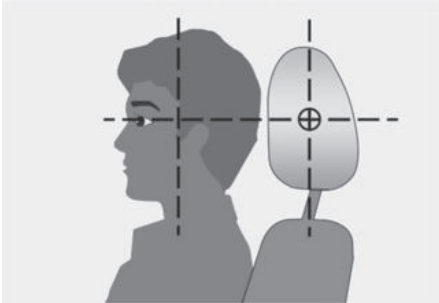

- NEVER adjust the head restraint position of the driver's seat when the vehicle is in motion.
- Adjust the head restraint as close to the passenger's head as possible. Do not use a seat cushion that holds the body away from the seatback.
- Make sure the head restraint locks into position after adjusting it.

### WARNING

When sitting in the rear seat, do not adjust the height of the head restraint to the lowest position.

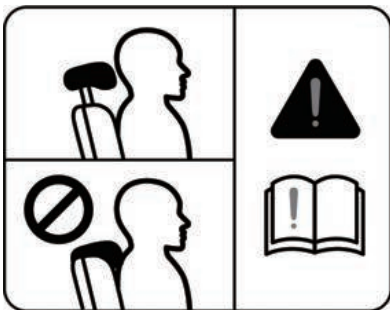

### CAUTION

When there is no occupant in the rear seats, adjust the height of the head restraint to the lowest position. The rear seat head restraint can reduce the visibility of the rear area.

### NOTICE

To prevent damage, NEVER hit or pull on the head restraints.

### *Front seat head restraints*

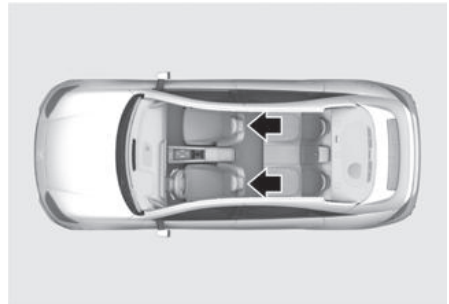

The driver's and front passenger's seats are equipped with adjustable head restraints for the passengers safety and comfort.

### Adjusting the height up and down

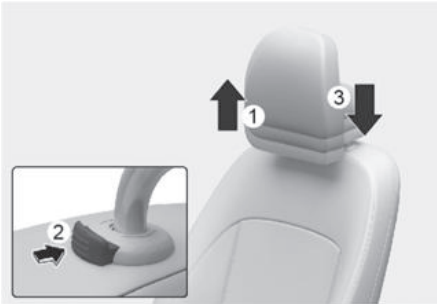

To raise the head restraint:

1. Pull it up to the desired position (1).

To lower the head restraint:

1. Push and hold the release button (2) on the head restraint support.
2. Lower the head restraint to the desired position (3).

#### **NOTICE**



If you recline the seatback towards the front with the head restraint and seat cushion raised, the head restraint may come in contact with the sunvisor or other parts of the vehicle.

### Removal/Reinstallation

#### Manual adjustment seat



#### Power adjustment seat



To remove the head restraint:

1. Recline the seatback (2) with the seatback angle switch (1).
2. Pull up the head restraint to the upmost position and press the release button (3) to remove the head restraint (4).

#### **⚠ WARNING**

NEVER allow anyone to travel in a seat with the head restraint removed.



Manual adjustment seat

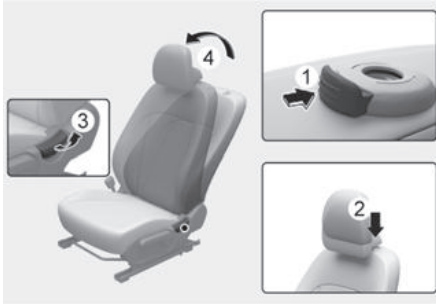

Power adjustment seat

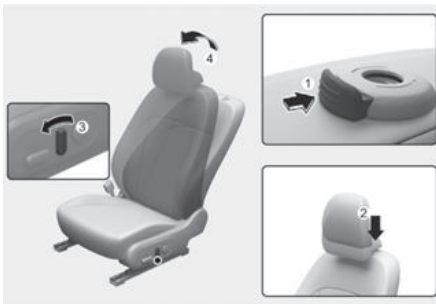

To reinstall the head restraint :

1. Recline the seat back by pressing seatback angle lever or switch (3).
2. Put the head restraint poles (2) into the holes while pressing the release button (1).
3. Adjust the head restraint to the appropriate height.
4. Adjust the seatback angle (4) with the seatback angle switch (3).

### **WARNING**

Always make sure the head restraint locks into position after reinstalling and adjusting it properly.

## Rear seat head restraints

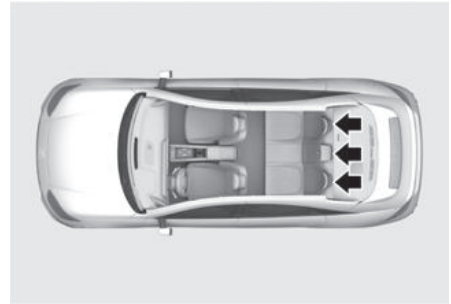

The rear seats are equipped with head restraints in all the seating positions for the passenger's safety and comfort.

### Adjusting the height up and down

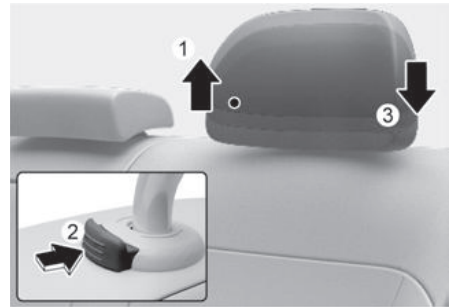

To raise the head restraint:

1. Pull it up to the desired position (1).

To lower the head restraint:

1. Push and hold the release button (2) on the head restraint support.
2. Lower the head restraint to the desired position (3).

### Removal/Reinstallation

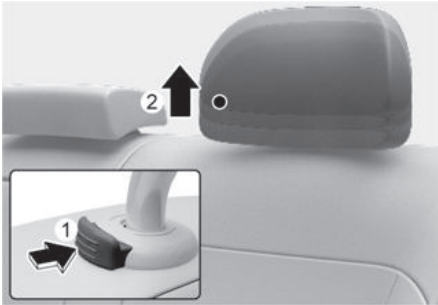

To remove the head restraint:

1. Raise the head restraint as far as it can go.
2. Press the head restraint release button (1) while pulling the head restraint up (2).



To reinstall the head restraint:

1. Put the head restraint poles into the holes (2) while pressing the release button (1).
2. Adjust the head restraint to the appropriate height.

### Seat Warmers

Seat warmers are provided to warm the seats during cold weather.

During mild weather or under conditions where the operation of the seat warmer is not needed, keep the seat warmers off.

#### **! WARNING**

The seat warmers can cause a **SERIOUS BURN**, even at low temperatures and especially if used for long periods of time.

Passengers must be able to feel if the seat is becoming too warm so they can turn it off, if needed.

Seat warmer consume large amounts of electricity. Please avoid using seat warmers while the vehicle is off in order to prevent battery discharge.

People who cannot detect temperature change or pain to the skin should use extreme caution, especially the following types of passengers:

- Infants, children, elderly or disabled persons, or hospital outpatients.
- People with sensitive skin or who burn easily.
- Fatigued individuals.
- Intoxicated individuals.
- People taking medication that can cause drowsiness or sleepiness.

#### **! WARNING**

**NEVER** place anything on the seat that insulates against heat when the seat warmer is in operation, such as a blanket or seat cushion. This may cause the seat warmer to overheat, causing a burn or damage to the seat.

## NOTICE

To prevent damage to the seat warmers and seats:

- Never use a solvent such as paint thinner, benzene, alcohol or gasoline to clean the seats.
- Do not place heavy or sharp objects on seats equipped with seat warmers.
- Do not change the seat cover. It may damage the seat warmer.

## Front seat warmers

 if equipped

Infotainment system

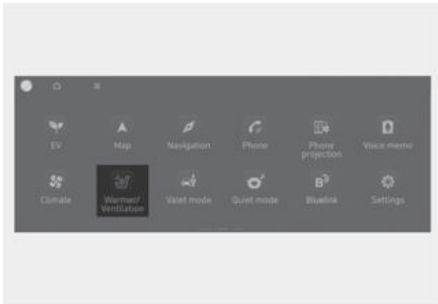



While the vehicle is running, touch Heating/Ventilation icon in the infotainment system.

Climate control panel



Press  in the front climate control panel.



To activate seat warmer of each front seats, touch  icon on the infotainment system. Adjust the temperature by pressing either  or  icons.

The seat warmer will automatically stop when the seat temperature reaches certain level and will automatically reactivate when the seat temperature drops below certain temperature.

- Automatic temperature control

The seat warmer starts to automatically control the seat temperature in order to prevent low temperature burns after being manually turned on.

OFF → HIGH (3) → MEDIUM (2) → LOW (1)  

You may manually touch the icon to increase seat temperature. However, the seat temperature is automatically adjusted again.

- Auto. Controls That Use Climate Control Settings (for driver's seat)

The seat warmer automatically controls the seat temperature depending on the ambient temperature when the vehicle is on (READY indicator on).

To use this function, it can be enabled from the Settings menu in the infotainment system. Select: **Setup > Vehicle > Seat > Heated/Ventilated Features > Auto. Controls That Use Climate Control Settings > Seat Warmer/Ventilation**

- The seat warmer defaults to the OFF position whenever the Start/Stop button is pressed to the ON position. However, if the Auto. Controls That Use Climate Control Settings function is on, the driver's seat warmer turns on and off depending on the ambient temperature.

**i Information**

The infotainment system may change after software updates. For more information, refer to the user's manual provided in the infotainment system and the quick reference guide.

**Rear seat warmers**

**If equipped**



- While the vehicle is running, press seat warmer switches located in each seats to warm the rear seat.
- The seat warmer will automatically stop when the seat temperature reaches certain level and will automatically reactivate when the seat temperature drops below certain temperature.
- Manual temperature control  
Each time you press the switch, the temperature setting of the seat is changed as follows :



- Automatic temperature control  
The seat warmer starts to automatically control the seat temperature in order to prevent low temperature burns after being manually turned on.



You may manually push the switch to increase seat temperature. However, the seat temperature is automatically adjusted again.

- The seat warmer defaults to the OFF position whenever the Start/Stop button is pressed to the ON position.
- The rear seat warmers can be adjusted from the infotainment system.

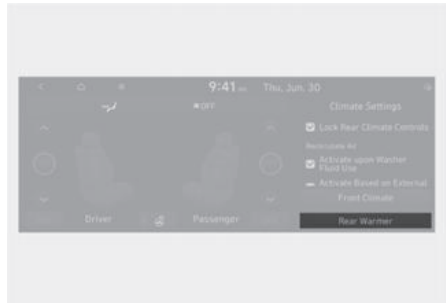

- Touch rear heat icon in the Heating/Ventilation infotainment system.



To activate seat warmer of each rear seats, touch ^ icon on the infotainment system. Adjust the temperature by pressing either ^ or v icons.

## **i** Information

The infotainment system may change after software updates. For more information, refer to the user's manual provided in the infotainment system and the quick reference guide.

## Air Ventilation Seats

The air ventilation seats are provided to cool the front seats by blowing air through small vent holes on the surface of the seat cushions and seatbacks.

When the operation of the air ventilation seat is not needed, keep the air ventilation seats off.

### NOTICE

To prevent damage to the air ventilation seats:

- Never use a solvent such as paint thinner, benzene, alcohol or gasoline to clean the seats.
- Avoid spilling liquids on the surface of the front seats and seatbacks; this may cause the air vent holes to block and not work properly.
- Do not place materials such as plastic bags or newspapers under the seats. They may block the air intake causing malfunction of the air vent.
- Do not change the seat covers. It may damage the air ventilation seat.
- If the air vents do not operate, restart the vehicle. If there is no change, have the vehicle inspected by an authorized HYUNDAI dealer.

## Front air ventilation seats

**+** if equipped

Infotainment system

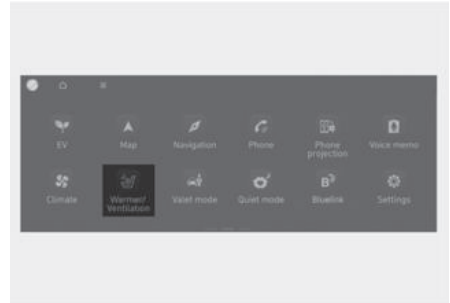

While the vehicle is running, touch Heating/Ventilation icon in the infotainment system.



Climate control panel



Press  in the front climate control panel.



To activate air ventilation of each front seats, touch  icon on the infotainment

system. Adjust the airflow by pressing either  or  icons.

- If the air ventilation seat is position to 'HIGH', fan speed increases depending on the vehicle speed and driving time.
- Use the air ventilation seat with the air conditioning on for more effective ventilation.
- It may take 3-5 minutes after switch operation to feel the temperature change.
- Auto. Controls That Use Climate Control Settings (for driver's seat)

The air ventilation seat automatically controls the seat temperature depending on the ambient temperature when the vehicle is on (**READY** indicator on).

To use this function, it can be enabled from the Settings menu in the infotainment system. Select: **Setup > Vehicle > Seat > Heated/Ventilated Features > Auto. Controls That Use Climate Control Settings > Seat Warmer/Ventilation**

- The air ventilation seats defaults to the OFF position whenever the Start/Stop button is pressed to the ON position. However, if the Auto. Controls That Use Climate Control Settings function is on, the driver's air ventilation seat turns on and off depending on the ambient temperature.

### Information

The infotainment system may change after software updates. For more information, refer to the user's manual provided in the infotainment system and the quick reference guide.

## Seat Belts

This section describes how to use the seat belts properly. It also describes some of the things not to do when using seat belts.

### Seat Belt Safety Precautions

Always fasten your seat belt and make sure all passengers have fastened their seat belts before starting any trip. Airbags are designed to supplement the seat belt as an additional safety device, not a replacement. Most states require all occupants of a vehicle to wear seat belts.

#### WARNING

Seat belts must be used by ALL passengers whenever the vehicle is moving. Take the following precautions when adjusting and wearing seat belts:

- Children under the age of 13 should be properly restrained in the rear seats.
- Never allow children to ride in the front passenger seat, unless the airbag is deactivated. If a child is seated in the front passenger seat, move the seat as far back as possible. And the child must always be restrained in the seat properly.
- NEVER allow an infant or child to be carried on an occupant's lap.
- NEVER ride with the seatback reclined when the vehicle is moving.
- Do not allow children to share a seat or seat belt.
- Do not wear the shoulder belt under your arm or behind your back.
- NEVER place a seat belt over fragile objects. If there is a sudden stop or impact, the seat belt can damage it.

- Do not use the seat belt if it is twisted. A twisted seat belt will not protect you properly in an accident.
- Do not use a seat belt if the webbing or hardware is damaged.
- Do not latch the seat belt into the buckles of other seats.
- NEVER unfasten the seat belt while driving. This may cause loss of vehicle control resulting in an accident.
- Make sure there is nothing in the buckle interfering with the seat belt latch mechanism, because any materials in the buckle can cause the seat belt not to be fastened securely.
- No modifications or additions should be made by the user which will either prohibit the seat belt adjusting devices from operating to remove slack, or prohibit the seat belt assembly from being adjusted to remove slack.

### WARNING

Damaged seat belts and seat belt assemblies will not operate properly. Always replace:

- Frayed, contaminated, or damaged webbing.
- Damaged hardware.
- The entire seat belt assembly after it has been worn in an accident, even if damage to webbing or assembly is not apparent.

## Seat Belt Warning Light

### *Driver's seat belt warning*

Instrument cluster



As a reminder to the driver, the driver's seat belt warning lights will illuminate for about 6 seconds each time the Start/Stop button is in the ON position regardless of belt fastening. If the seatbelt is not fastened, the warning chime will sound for about 6 seconds.

If you start to drive without the seat belt fastened or you unfasten the seat belt when you drive under 12 mph (20 km/h) or stop, the corresponding warning light will illuminate.

If you start to drive without the seat belt fastened or you unfasten the seat belt when you drive 12 mph (20 km/h) and faster, the warning light will blink and warning chime will sound for about 100 seconds.

When the seat belt is unfastened during driving, the warning light will illuminate when the speed is under 12 mph (20 km/h).

When the speed is 12 mph (20 km/h) and faster, the warning light will blink and warning chime will sound for about 100 seconds.

### Front passenger's seat belt warning

As a reminder to the front passenger, the front passenger's seat belt warning lights will illuminate for about 6 seconds each time the Start/Stop button is in the ON position regardless of belt fastening.

If you start to drive without the seat belt fastened or you unfasten the seat belt when you drive under 12 mph (20 km/h) or stop, the corresponding warning light will illuminate.

If you start to drive without the seat belt fastened or you unfasten the seat belt when you drive 12 mph (20 km/h) and faster, the warning light will blink and warning chime will sound for about 100 seconds.

When the seat belt is unfastened during driving, the warning light will illuminate when the speed is under 12 mph (20 km/h). When the speed is 12 mph (20 km/h) and faster, the warning light will blink and warning chime will sound for about 100 seconds.

#### **WARNING**

Riding in an improper position adversely affects the front passenger's seat belt warning system. It is important for the driver to instruct the passenger to properly be seated as instructed in this manual.

#### **Information**

- Although the front passenger seat is not occupied, the seat belt warning light will blink or illuminate for 6 seconds.
- The front passenger's seat belt warning may operate when luggage is placed on the front passenger seat.

### Rear passenger's seat belt warning

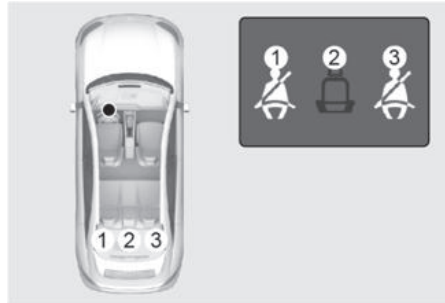

#### For rear left and right side seat

- As a reminder to the rear passenger, the rear passenger's seat belt warning lights will illuminate for about 6 seconds each time the Start/Stop button is in the ON position regardless of belt fastening.
- If you unfasten the seat belt when you drive under 12 mph (20 km/h), the corresponding warning light will continue to illuminate until you fasten the seat belt.
- If you unfasten the seat belt when you drive 12 mph (20 km/h) and faster, the seat belt warning chime will sound for about 35 seconds and the corresponding warning light will blink.
- When the seat belt is unfastened during driving, the warning lights will illuminate when the speed is under 12 mph (20 km/h).
- When the speed is 12 mph (20 km/h) and faster, the warning light will blink and warning chime will sound for about 35 seconds.



### For rear center seat

- As a reminder to the rear passenger, the rear passenger's seat belt warning lights will illuminate for about 6 seconds each time the Start/Stop button is in the ON position regardless of belt fastening.
- If you unfasten the seat belt when you drive under 12 mph (20 km/h), the corresponding warning light will continue to illuminate for about 70 seconds.
- If you unfasten the seat belt when you drive over 12 mph (20 km/h), the seat belt warning chime will sound for about 35 seconds and the corresponding warning light will blink.
- If the rear door is opened under 6 mph (10 km/h), warning light and warning sound does not work even if driving over 12 mph (20 km/h).

## Seat Belt Restraint System

### WARNING



Improperly positioned seat belts may increase the risk of serious injury in an accident. Take the following precautions when adjusting the seat belt:

- Position the lap portion of the seat belt as low as possible across your hips, not on your waist, so that it fits snugly. This allows your strong pelvic bones to absorb the force of the crash, reducing the chance of internal injuries.
- Position one arm under the shoulder belt and the other over the belt, as shown in the illustration.
- Always position the shoulder belt anchor into the locked position at the appropriate height.
- Never position the shoulder belt across your neck or face.

### **Driver's Seat Belt – 3-point system with emergency locking retractor**

To fasten your seat belt:

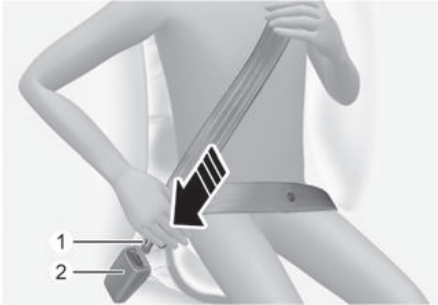

Pull it out of the retractor and insert the metal tab (1) into the buckle (2). An audible “click” sounds when the tab locks into the buckle. Make sure the seat belt is not twisted.



Place the lap belt (1) portion across your hips and the shoulder belt (2) portion across your chest.

The seat belt automatically adjusts to the proper length after the lap belt portion is adjusted manually so that it fits snugly around your hips.

If you lean forward in a slow, easy motion, the belt extends and moves with you. If there is a sudden stop or collision, the belt is locked in place. It also locks if you try to lean forward too quickly.

### **i Information**

If you cannot smoothly pull the seat belt out from the retractor, firmly pull the seat belt out and release it. After release, the belt may be pulled out smoothly.

### **Height adjustment**

You can adjust the height of the shoulder belt anchor to one of the four different positions for maximum comfort and safety.

The shoulder portion should be adjusted so it lies across your chest and midway over your shoulder nearest the door, not over your neck.

Front seat

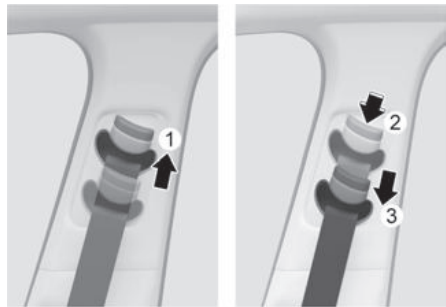

To adjust the height of the seat belt anchor, lower or raise the height adjuster into an appropriate position.

To raise the height adjuster, pull it up (1). To lower it, push it down (3) while pressing the height adjuster button (2).

Release the button to lock the anchor into position. Try sliding the height adjuster to make sure that it has locked into position.

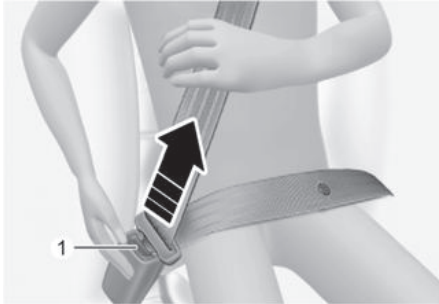
**To release your seat belt:**

Press the release button (1) in the locking buckle.

The belt should automatically draw back into the retractor. If this does not happen, check the belt is not twisted, then try again.

**Rear Seat Belts – 3-point system with convertible locking retractor**

This type of seat belt combines both an emergency locking retractor and an automatic locking retractor. Convertible retractor type seat belts are installed in the rear seat positions to help accommodate the installation of child restraint systems.

A convertible retractor is also installed in the front passenger seat position, children should always be seated in the rear and never place any infant/child restraint system in the front seat.

**To fasten your seat belt:**

Pull the seat belt out of the retractor and insert the metal tab into the buckle. An audible “click” sounds when the tab locks into the buckle. Pull the shoulder portion of the belt to snug the belt across your hips and remove slack. Make sure the seat belt is not twisted. When not securing a child restraint, the seat belt automatically adjusts to the proper length only after the lap belt portion of the seat belt is adjusted manually so that it fits snugly across your hips.

When the seat belt has been fully extended from the retractor to allow for the installation of a child restraint system, the seat belt operation changes to allow the belt to retract, but not to extend (Automatic Locking Retractor Type). For more information, refer to the “Child Restraint System (CRS)” section in this chapter.

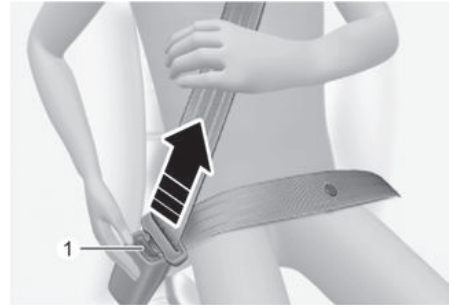
**To release your seat belt:**

Press the release button (1) in the locking buckle.

The belt should automatically draw back into the retractor. If this does not happen, check the belt is not twisted, then try again.

**i Information**

- The emergency locking mode allows seated passengers to move freely in their seats while keeping some tension on the belt. During a collision or sudden stop, the retractor automatically locks the belt to help restrain the passengers.
- To deactivate the automatic locking mode, unbuckle the seat belt and allow the belt to fully retract.

### Rear center seatbelt (3-point rear center seat belt)

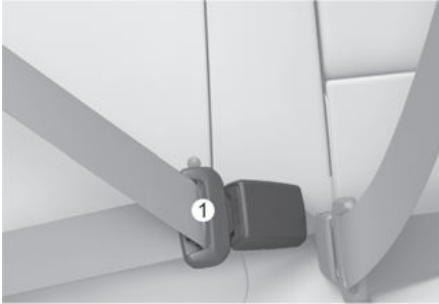

Insert the tongue plate (1) into the buckle until an audible “click” is heard, indicating the latch is locked. Pull the shoulder portion of the belt to snug the belt across your hips and remove slack.

Make sure the seat belt is not twisted.

When using the rear center seat belt, use the buckle with the “CENTER” mark.

#### **i** Information

If you cannot pull out the safety belt from the retractor, firmly pull the belt out and release it. After release, pull out the belt smoothly.

#### **!** WARNING

Make sure that the seatback is locked in place when using the rear center seat belt.

If not, the seatback may move when there is a sudden stop or collision, which could result in serious injury.

### Pretensioner seat belt

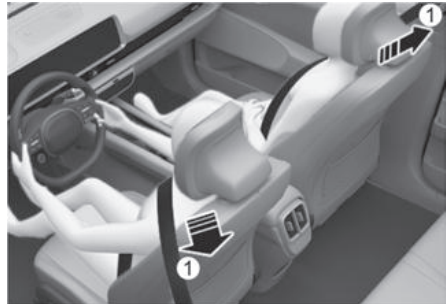

(1) Retractor Pretensioner

Your vehicle is equipped with driver's and front passenger's and rear passengers Pretensioner Seat Belts (Retractor Pretensioner). The purpose of the pretensioner is to make sure the seat belts fit tightly against the occupant's body in certain frontal or side collision(s). The Retractor Pretensioner may be activated in certain crashes where the frontal collision(s) is severe enough.

When the vehicle stops suddenly, or if the occupant tries to lean forward too quickly, the seat belt retractor will lock into position. In certain frontal or side collision(s), the pretensioner will activate and pull the seat belt into tighter contact against the occupant's body.

If the system senses excessive tension on the driver or passenger's seat belt when the pretensioner system activates, the load limiter inside the retractor pretensioner will release some of the pressure on the affected seat belt.

#### **!** WARNING

- Always wear your seat belt and sit properly in your seat.
- Do not use the seat belt if it is loose or twisted. A loose or twisted seat belt will not protect you properly in an accident.
- Do not place anything near the buckle. This may adversely affect the buckle and cause it to function improperly.

- Always replace your pretensioners after activation or an accident.
- NEVER inspect, service, repair or replace the pretensioners yourself. Have the pretensioners inspected, serviced, repaired or replaced by an authorized HYUNDAI dealer.
- Do not hit the seat belt assemblies.

### WARNING

Do not touch the pretensioner seat belt assemblies for several minutes after they have been activated. When the pretensioner seat belt mechanism deploys during a collision, the pretensioner can become hot and can burn you.

### CAUTION

Body work on the front area of the vehicle may damage the pretensioner seat belt system. Therefore, have the system serviced by an authorized HYUNDAI dealer.

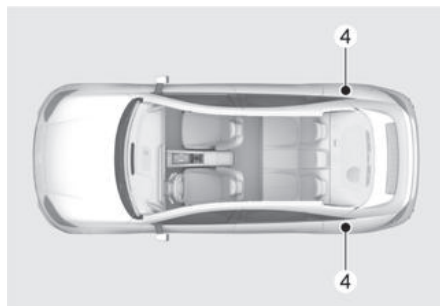
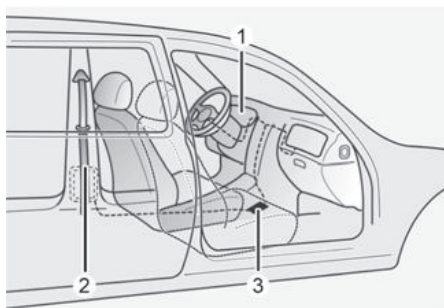

The Pretensioner Seat Belt System consists mainly of the following components. Their locations are shown in the illustration above:

- (1) SRS airbag warning light
- (2) Retractor pretensioner
- (3) SRS control module
- (4) Rear retractor pretensioner

### NOTICE

The sensor that activates the SRS control module is connected with the pretensioner seat belts. The SRS airbag warning light on the instrument cluster will illuminate for about 3-6 seconds after the Start/Stop button is in the ON position, and then it should turn off.

If the pretensioner is not working properly, the warning light will illuminate even if the SRS airbag is not malfunctioning. If the warning light does not illuminate, stays illuminated or illuminates when the vehicle is being driven, have the pretensioner seat belts and/or SRS control module inspected by an authorized HYUNDAI dealer as soon as possible.

## **i** Information

- Pretensioner seat belts may be activated in certain frontal or side collisions or rollover situations.
  - When the pretensioner seat belts are activated, a loud noise may be heard and fine dust, which may appear to be smoke, may be visible in the passenger compartment. These are normal operating conditions and are not hazardous.
  - Although it is non-toxic, the fine dust may cause skin irritation and should not be inhaled for prolonged periods. Wash all exposed skin areas thoroughly after an accident in which the pretensioner seat belts were activated.
- 

## Additional Seat Belt Safety Precautions

### **Seat belt use during pregnancy**

The seat belt should always be used during pregnancy. The best way to protect your unborn child is to protect yourself by always wearing the seat belt. Pregnant women should always wear a lap-shoulder seat belt. Place the shoulder belt across your chest, routed between your breasts and away from your neck. Place the lap belt below your belly so that it fits **SNUGLY** across your hips and pelvic bone, under the rounded part of the belly.

### **! WARNING**

To reduce the risk of serious injury or death to an unborn child during an accident, pregnant women should **NEVER** place the lap portion of the seat belt above or over the area of the abdomen where the unborn child is located.

---

## **Seat belt use and children**

### **Infant and small children**

Most states have Child Restraint System laws which require children to travel in approved Child Restraint System devices, including booster seats. The age at which seat belts can be used instead of Child Restraint System differs among states, so you should be aware of the specific requirements in your state, and where you are travelling. Infant and Child Restraint System must be properly placed and installed in a rear seat.

For more information refer to the “Child Restraint System (CRS)” section in this chapter.

### **! WARNING**

**ALWAYS** properly restrain infants and small children in a Child Restraint System appropriate for the child's height and weight.

To reduce the risk of serious injury or death to a child and other passengers, **NEVER** hold a child in your lap or arms when the vehicle is moving. The violent forces created during an accident will tear the child from your arms and throw the child against the interior of the vehicle.

---

Small children are best protected from injury in an accident when properly restrained in the rear seat by a child restraint system that meets the requirements of the Federal Motor Vehicle Safety Standards. Before buying any child restraint system, make sure that it has a label certifying that it meets Federal Motor Vehicle Safety Standard FMVSS 213. The restraint must be appropriate for your child's height and weight. Check the label on the child restraint for this information. For more information, refer to the “Child Restraint System (CRS)” section in this chapter.

### Larger children

Children under age 13 and who are too large for a booster seat should always occupy the rear seat and use the available lap/shoulder belts. A seat belt should lie across the upper thighs and be snug across the shoulder and chest to restrain the child safely. Check belt fit periodically. A child's squirming could put the belt out of position. In the event of an accident, children are afforded the best safety restrained by a proper Child Restraint System in the rear seats.

If a larger child over age 13 must be seated in the front seat, the child must be securely restrained by the available lap/shoulder belt and the seat should be placed in the rearmost position.

If the shoulder belt portion slightly touches the child's neck or face, try placing the child closer to the center of the vehicle. If the shoulder belt still touches their face or neck, they need to be returned to an appropriate booster seat in the rear seat.

#### WARNING

- Always make sure larger children's seat belts are worn and properly adjusted.
- NEVER allow the shoulder belt to contact the child's neck or face.
- Do not allow more than one child to use a single seat belt.

### **Seat belt use and injured people**

A seat belt should be used when an injured person is being transported. Consult a physician for specific recommendations.

### **One person per belt**

Two people (including children) should never attempt to use a single seat belt. This could increase the severity of injuries in case of an accident.

### **Do not lie down**

Sitting in a reclined position when the vehicle is in motion can be dangerous. Even when buckled up, the protections of your restraint system (seat belts and/or airbags) is greatly reduced by reclining your seatback.

Seat belts must be snug against your hips and chest to work properly.

During an accident, you could be thrown into the seat belt, causing neck or other injuries.

The more the seat back is reclined, the greater the chance for the passenger's hips to slide under the lap belt or the passenger's neck to strike the shoulder belt.

#### WARNING

- NEVER ride with a reclined seatback when the vehicle is moving.
- Riding with a reclined seatback increases your chance of serious or fatal injuries in the event of a collision or sudden stop.
- Driver and passengers should always sit well back in their seats with the seatbacks upright and should be belted properly.

## Care of Seat Belts

Seat belt systems should never be disassembled or modified. In addition, care should be taken to assure that seat belts and belt hardware are not damaged by seat hinges, doors or other abuse.

### ***Periodic inspection***

All seat belts should be inspected periodically for wear or damage of any kind. Any damaged parts should be replaced as soon as possible.

### ***Keep belts clean and dry***

Seat belts should be kept clean and dry. If belts become dirty, they can be cleaned by using a mild soap solution and warm water. Bleach, dye, strong detergents or abrasives should not be used because they may damage and weaken the fabric.

### ***When to replace seat belts***

The entire seat belt assembly or assemblies should be replaced if the vehicle has been involved in an accident. This should be done even if no damage is visible. Consult an authorized HYUNDAI dealer.

## Child Restraint System (CRS)

### Children Always in the Rear

#### **WARNING**

Always properly restrain children in the rear seats of the vehicle. Children of all ages are safer when restrained in the rear seat. A child riding in the front passenger seat can be forcefully struck by an inflating airbag resulting in **SERIOUS INJURY** or **DEATH**.

---

Children under age 13 should always ride in the rear seats and must always be properly restrained to minimize the risk of injury in an accident, sudden stop or sudden maneuver.

According to accident statistics, children are safer when properly restrained in the rear seats than in the front seat. Even with airbags, children can be seriously injured or killed. Children too large for a Child Restraint System must use the seat belts provided.

All 50 states have child restraint laws which require children to travel in approved Child Restraint Systems.

The laws governing the age or height/weight restrictions at which seat belts can be used instead of Child Restraint System differ among states, so you should be aware of the specific requirements in your state, and where you are travelling.

Child Restraint Systems must be properly placed and installed in the rear seat. You must use a commercially available Child Restraint System that meets the requirements of the Federal Motor Vehicle Safety Standards (FMVSS 213).



Child Restraint Systems are generally designed to be secured in a vehicle seat by lap belt portion of a lap/shoulder belt, or by a LATCH system in the rear seats of the vehicle.

### **Child Restraint System (CRS)**

Infants and younger children must be restrained in an appropriate rearward-facing or forward-facing CRS that has first been properly secured to the seat of the vehicle. Read and comply with the instructions for installation and use provided by the manufacturer of the Child Restraint System.

#### **WARNING**

An improperly secured child restraint can increase the risk of **SERIOUS INJURY** or **DEATH** in an accident. Always take the following precautions when using a Child Restraint System:

- NEVER install a child or infant restraint in the front passenger's seat.
- Always properly secure the child restraint to a rear seat of the vehicle.
- Always follow the child restraint system manufacturer's instructions for installation and use.
- Always properly restrain your child in the child restraint.
- If the vehicle head restraint prevents proper installation of a child seat (as described in the child restraint system manual), the head restraint of the respective seating position shall be readjusted or entirely removed.
- Do not use an infant carrier or a child safety seat that "hooks" over a seatback, it may not provide adequate protection in an accident.
- After an accident, have an authorized HYUNDAI dealer check the child restraint system, seat belts, tether anchors and lower anchors.

### **Selecting a Child Restraint System (CRS)**

When selecting a Child Restraint System for your child, always:

- Make sure the Child Restraint System has a label certifying that it meets applicable Federal Motor Vehicle Safety Standards (FMVSS 213).
- Select a Child Restraint System based on your child's height and weight. The required label or the instructions for use typically provide this information.
- Select a Child Restraint System that fits the vehicle seating position where it will be used.
- Read and comply with the warnings and instructions for installation and use provided with the Child Restraint System.

### **Child Restraint System types**

There are three main types of Child Restraint Systems: rearward-facing, forward-facing and booster Child Restraint Systems.

They are classified according to the child's age, height and weight.

### Rearward-facing Child Restraint System



A rearward-facing Child Restraint System provides restraint with the seating surface against the back of the child. The harness system holds the child in place, and in an accident, acts to keep the child positioned in the Child Restraint Systems and reduce the stress to the fragile neck and spinal cord.

All children under the age of one year must always ride in a rearward-facing Child Restraint System. Convertible and 3-in-1 Child Restraint Systems typically have higher height and weight limits for the rearward-facing position, allowing you to keep your child rearward-facing for a longer period of time.

Keep using Child Restraint Systems in the rearward-facing position as long as children fit within the height and weight limits allowed by the Child Restraint System's manufacturer. It's the best way to keep them safe.

Once your child has outgrown the rearward-facing Child Restraint System, your child is ready for a forward-facing Child Restraint System with a harness.

#### **WARNING**

NEVER install a child or infant restraint in the front passenger's seat.

Placing a rearward-facing child restraint in the front seat can result in **SERIOUS INJURY** or **DEATH** if the child restraint is struck by an inflating airbag.

---

### Forward-facing Child Restraint System



A forward-facing Child Restraint System provides restraint for the child's body with a harness. Keep children in a forward-facing Child Restraint System with a harness until they reach the top height or weight limit allowed by your Child Restraint System's manufacturer. Once your child outgrows the forward-facing Child Restraint System, your child is ready for a booster seat.

#### **Booster seats**

A booster seat is a Child Restraint System designed to improve the fit of the vehicle's seat belt system. A booster seat positions the seat belt so that it fits properly over the stronger parts of your child's body. Keep your children in booster seats until they are big enough to fit in a seat belt properly.

For a seat belt to fit properly, the lap belt must lie comfortable across the upper thighs, not the stomach. The shoulder belt should lie comfortable across the shoulder and chest and not across the neck or face. Children under age 13 must always be properly restrained to minimize the risk of injury in an accident, sudden stop or sudden maneuver.

## Installing a Child Restraint System (CRS)

### WARNING

Before installing your Child Restraint System always:

Read and follow the instructions provided by the manufacturer of the Child Restraint System.

Failure to follow all warnings and instructions could increase the risk of the SERIOUS INJURY or DEATH if an accident occurs.

---

### WARNING

If the vehicle head restraint prevents proper installation of a Child Restraint System, the head restraint of the respective seating position shall be readjusted or entirely removed.

---

After selecting a proper Child Restraint System for your child and checking that the Child Restraint System fits properly on the seating position, there are three general steps for a proper installation:

- **Properly secure the Child Restraint System to the vehicle.** All Child Restraint Systems must be secured to the vehicle with the lap belt or lap part of a lap/shoulder belt or with the lower anchor and/or tether anchor and/or with the support leg.

- **Make sure the Child Restraint System is firmly secured.** After installing a Child Restraint System to the vehicle, push and pull the seat forward and from side-to-side to verify that it is securely attached to the seat. A Child Restraint System secured with a seat belt should be installed as firmly as possible. However, some side-to-side movement can be expected. When installing a Child Restraint System, adjust the vehicle seat and seatback (up and down, forward and rearward) so that your child fits in the Child Restraint System in a comfortable manner.
- **Secure the child in the Child Restraint System.** Make sure the child is properly strapped in the Child Restraint System according to the Child Restraint System manufacturer's instructions.

### CAUTION

A Child Restraint System in a closed vehicle can become very hot. To prevent burns, check the seating surface and buckles before placing your child in the Child Restraint System.

---

### Lower Anchors and Tether for Children (LATCH System)

The LATCH system holds a Child Restraint System during driving and in an accident. This system is designed to make installation of the Child Restraint System easier and reduce the possibility of improperly installing your Child Restraint System. The LATCH system uses anchors in the vehicle and attachments on the Child Restraint System. The LATCH system eliminates the need to use seat belts to secure the Child Restraint System to the rear seats.

Lower anchors are metal bars built into the vehicle. There are two lower anchors for each LATCH seating position that will accommodate a Child Restraint System with lower attachments.

To use the LATCH system in your vehicle, you must have a Child Restraint System with LATCH attachments.

The Child Restraint System manufacturer will provide you with instructions on how to use the Child Restraint System with its attachments for the LATCH anchorages.

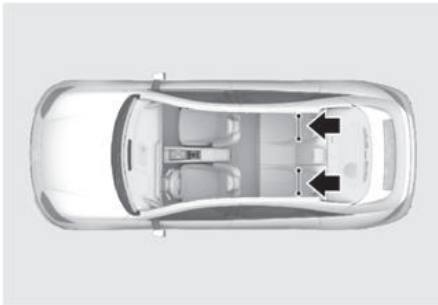

LATCH anchors have been provided in the left and right outboard rear seating positions. Their locations are shown in the illustration. There are no LATCH anchors provided for the center rear seating position.

### WARNING

Do not attempt to install a Child Restraint System using LATCH anchors in the rear center seating position. There are no LATCH anchors provided for this seat. Using the outboard seat anchors can damage the anchors which may break or fail in a collision resulting in serious injury or death.

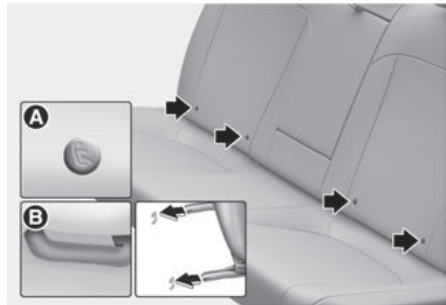

[A] Lower Anchor Position Indicator  
[B] Lower Anchor

The lower anchor position indicator symbols are located on the left and right rear seat backs to identify the position of the lower anchors in your vehicle (see arrows in illustration).

The LATCH anchors are located between the seatback and the seat cushion of the rear seat left and right outboard seating positions.

### WARNING

Before installing the Child Restraint System, make sure that there are no objects (for example, toy, pen, wire) around the lower anchor area. Those objects may damage either the seat belt system or the Child Restraint System during the installment procedure. If necessary, have the vehicle inspected by an authorized HYUNDAI dealer.

### **Securing a Child Restraint System with the “LATCH Anchors System”**

To install a LATCH-compatible Child Restraint System in either of the rear outboard seating positions:

1. Move the seat belt buckle away from the lower anchors.
2. Move any other objects away from the anchorages that could prevent a secure connection between the Child Restraint System and the lower anchors.
3. Place the Child Restraint System on the vehicle seat, then attach the seat to the lower anchors according to the instructions provided by the Child Restraint System manufacturer.
4. Follow the instructions of the Child Restraint System's manufacturer for proper installation and connection of the lower attachments on the Child Restraint System to the lower anchors.

#### **⚠ WARNING**

Take the following precautions when using the LATCH system:

- Read and follow all installation instructions provided with your Child Restraint System.
- To prevent the child from reaching and taking hold of unretracted seat belts, buckle all unused rear seat belts and retract the seat belt webbing behind the child. Children can be strangled if a shoulder belt becomes wrapped around their neck and the seat belt tightens.
- NEVER attach more than one Child Restraint System to a single anchorage. This could cause the anchor or attachment to come loose or break.
- Always have the LATCH system inspected by your dealer after an accident. An accident can damage the LATCH system and may not properly secure the Child Restraint System.

#### **NOTICE**

Make sure that the combined weight of the child and the child restraint system is less than 65 lbs. (30 kg) for each LATCH system.

### **Securing a Child Restraint System seat with “Top-tether Anchorage” system**

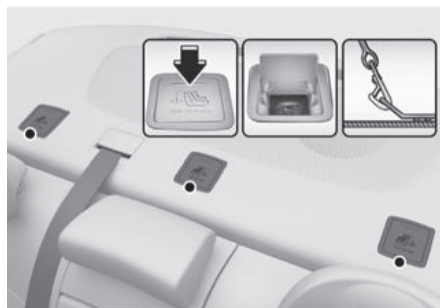

First secure the child restraint with the LATCH lower anchors or the seat belt. If the child restraint manufacturer recommends that the top tether strap be attached, attach and tighten the top tether strap to the top tether strap anchor.

Child restraint hook holders are located on the rear of the seatbacks.

#### **⚠ WARNING**

Take the following precautions when installing the top-tether:

- Read and follow all installation instructions provided with your Child Restraint System.
- NEVER attach more than one Child Restraint System to a single tether anchor. This could cause the anchorage or attachment to come loose or break.
- Do not attach the tether strap to anything other than the correct top-tether anchor. It may not work properly if attached to something else.

- Child Restraint System anchors are designed to withstand only those loads imposed by correctly fitted Child Restraint System.

Under no circumstances are the anchors to be used for adult seat belts or harnesses or for attaching other items or equipment to the vehicle.



To install the tether anchor:

1. Route the Child Restraint System top-tether strap over the seatback. Route the tether strap under the head restraint and between the head restraint posts, or route the tether strap over the top of the vehicle seatback. Make sure the strap is not twisted.
2. Connect the tether strap hook to the tether anchor, then tighten the top-tether strap according to the instructions of your Child Restraint System's manufacturer to firmly attach the Child Restraint System to the seat.
3. Check that the Child Restraint System is securely attached to the seat by pushing and pulling the seat forward-and-back and side-to-side.

### Securing a Child Restraint System with a lap/shoulder belt

When not using the LATCH system, all Child Restraint Systems must be secured to a rear seat with the lap part of a lap/shoulder belt.

### **WARNING**

ALWAYS place a rearward-facing Child Restraint System in the rear seat of the vehicle.

Placing a rearward-facing child restraint in the front seat can result in serious injury or death if the Child Restraint System is struck by an inflating airbag.

### Automatic locking mode

Since all passenger seat belts move freely under normal conditions and only lock under extreme or emergency conditions (emergency locking mode), you must manually pull the seat belt all the way out to shift the retractor to the "Automatic Locking" mode to secure a Child Restraint System.

The "Automatic Locking" mode will help prevent the normal movement of the child in the vehicle from causing the seat belt to loosen and compromise the Child Restraint System. To secure a Child Restraint System, use the following procedure.

To install a Child Restraint System on the rear seats, do the following:

1. Place the Child Restraint System on a rear seat and route the lap/shoulder belt around or through the Child Restraint System, following the Child Restraint System manufacturer's instructions. Make sure the seat belt webbing is not twisted.

### **i** Information

When using the rear center seat belt, you should also refer to the "Rear Seat Belts – 3-point system with convertible locking retractor" section in this chapter.



2. Fasten the lap/shoulder belt latch into the buckle. Listen for the distinct "click" sound.

### **i** Information

Position the release button so that it is easy to access in case of an emergency.



3. Pull the shoulder portion of the seat belt all the way out. When the shoulder portion of the seat belt is fully extended, it will shift the retractor to the "Automatic Locking" (child restraint) mode.
4. Slowly allow the shoulder portion of the seat belt to retract and listen for an audible "clicking" or "ratcheting" sound. This indicates that the retractor is in the "Automatic Locking" mode. If no distinct sound is heard, repeat steps 3 and 4.
5. Remove as much slack from the belt as possible by pushing down on the Child Restraint System while feeding the shoulder belt back into the retractor.
6. Push and pull on the Child Restraint System to confirm that the seat belt is holding it firmly in place. If it is not, release the seat belt and repeat steps 2 through 6.
7. Double check that the retractor is in the "Automatic Locking" mode by attempting to pull more of the seat belt out of the retractor. If you cannot, the retractor is in the "Automatic Locking" mode.

If your Child Restraint System manufacturer instructs or recommends you to use a tether anchor with the lap/shoulder belt, refer to the "Installing a Child Restraint System (CRS)" section in this chapter.

### **i** Information

When the seat belt is allowed to retract to its fully stowed position, the retractor will automatically switch from the “Automatic Locking” mode to the emergency lock mode for normal adult usage.

---

### **WARNING**

If the retractor is not in the “Automatic Locking” mode, the child restraint can move when your vehicle turns or stops suddenly. A child can be seriously injured or killed if the child restraint is not properly anchored in the car, including manually pulling the seat belt all the way out to shift the retractor to the “Automatic Locking” mode.

---

To remove the Child Restraint System, press the release button on the buckle and then pull the lap/shoulder belt out of the Child Restraint System and allow the seat belt to retract fully.



## Airbag - Supplemental Restraint System

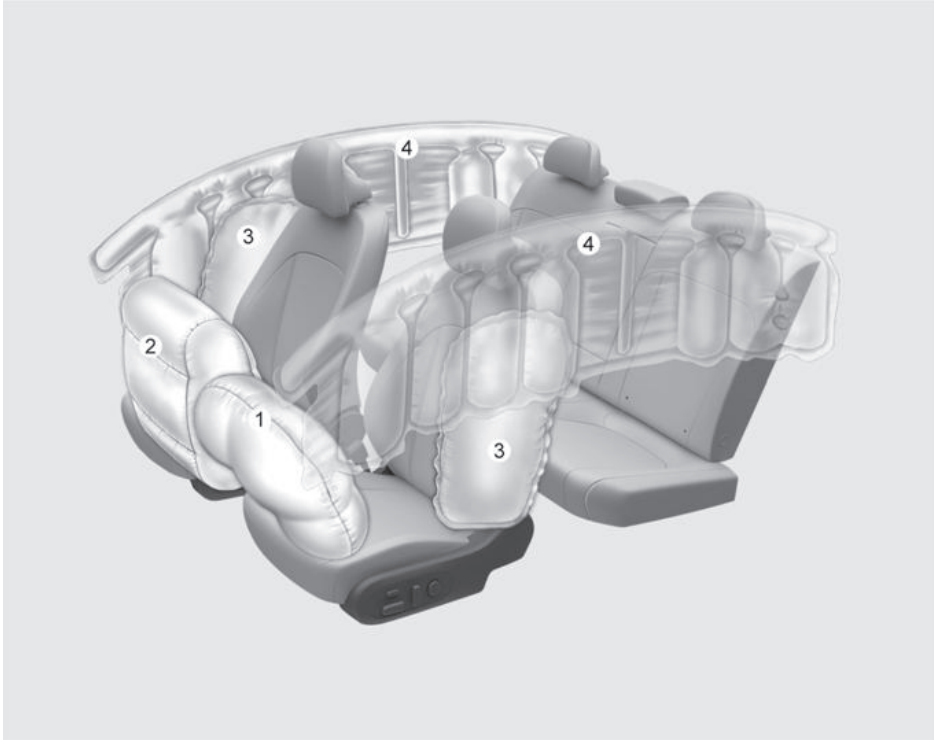

The actual airbags in the vehicle may differ from the illustration.

- (1) Driver's front airbag
- (2) Passenger's front airbag
- (3) Side airbag
- (4) Curtain airbag

Your vehicle is equipped with a Supplemental Airbag System for the driver's seat and front passenger's seats.

The front airbags are designed to supplement the three-point seat belts. For these airbags to provide protection, the seat belts must be worn at all times when driving.

You can be severely injured or killed in an accident if you are not wearing a seat belt. Airbags are designed to supplement seat belts, but do not replace them. Also, airbags are not designed to deploy in every collision. In some accidents, the seat belts are the only restraint protecting you.



### WARNING

#### AIRBAG SAFETY PRECAUTIONS

ALWAYS use seat belts and Child Restraint Systems - every trip, every time, everyone! Even with airbags, you can be seriously injured or killed in a collision if you are improperly belted or not wearing your seat belt when the airbag inflates.

NEVER place a child in any Child Restraint System or booster seat in the front passenger seat, unless the airbag is deactivated.

An inflating airbag could forcefully strike the infant or child causing serious or fatal injuries.

ABC - Always Buckle Children under age 13 in the back seat. It is the safest place for children of any age to ride. If a child age 13 or older must be seated in the front seat, he or she must be properly belted and the seat should be moved as far back as possible.

All occupants should sit upright with the seatback in an upright position, centered on the seat cushion with their seat belt on, legs comfortably extended and their feet on the floor until the vehicle is parked and the vehicle is turned off. If an occupant is out of position during an accident, the rapidly deploying airbag may forcefully contact the occupant causing serious or fatal injuries.

You and your passengers should never sit or lean unnecessarily close to the airbags or lean against the door or center console.

Move your seat as far back as possible from front airbags, while still maintaining control of the vehicle. The U.S. National Highway Traffic Safety Administration (NHTSA) recommends that drivers allow at least 10 in. (25 cm) between the center of the steering wheel and the chest.

---

## Where are the Airbags?

### **Driver's and passenger's front airbags**

Driver's front airbag



Passenger's front airbag

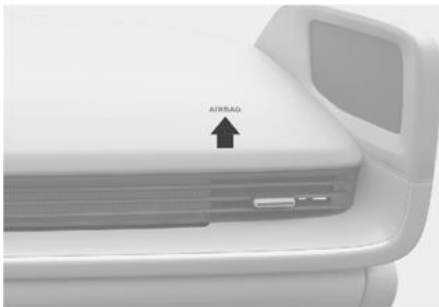

Your vehicle is equipped with a Supplemental Restraint System (SRS) and lap/shoulder belts at both the driver and passenger seating positions.

The SRS consists of airbags which are located in the center of the steering wheel and the passenger's side front panel pad above the glove box.

The airbags are labeled with the letters "AIRBAG" embossed on the pad covers.

The purpose of the SRS is to provide the vehicle's driver and front passengers with additional protection than that offered by the seat belt system alone in case of a frontal impact of sufficient severity.

The seat belt buckle sensors determine if the driver and front passenger's seat belts are fastened. These sensors provide the

ability to control the SRS deployment based on whether or not the seat belts are fastened, and how severe the impact is.

The advanced SRS offers the ability to control the airbag inflation within two levels. A first stage level is provided for moderate-severity impacts. A second stage level is provided for more severe impacts.

According to the impact severity, and seat belt usage, the SRS Control Module (SRSCM) controls the airbag inflation. Failure to properly wear seat belts can increase the risk or severity of injury in an accident.

### **⚠ WARNING**

To reduce the risk of serious injury or death from inflating front airbags, take the following precautions:

- Seat belts must be worn at all times to help keep occupants positioned properly.
- Move your seat as far back as possible from front airbags, while still maintaining control of the vehicle.
- Never lean against the door or center console.
- Do not allow the front passenger to place their feet or legs on the dashboard.
- Never place any objects (such as dashboard cover, mobile phone holder, cup holder, perfume or stickers) over or near the airbag modules on the steering wheel, instrument panel, windshield glass, and the front passenger's panel above the glove box. Such objects may cause harm if the vehicle is in a collision severe enough to cause the airbags to deploy.
- Do not attach any objects on the front windshield and inside mirror.

## Side airbags

Side airbag



Your vehicle is equipped with a side airbag in each front seat. The purpose of the airbag is to provide the vehicle's driver and the front passenger with additional protection than that offered by the seat belt alone.

The side airbags are designed to deploy during certain side impact collisions, depending on the crash severity, angle, speed and point of impact.

The side airbags on both sides of the vehicle are designed to deploy when a rollover is detected by a rollover sensor. (if equipped with rollover sensor)

The side airbags are not designed to deploy in all side impact or rollover situations.

The side airbags are designed to deploy during certain side impact collisions, depending on the crash severity.

For vehicles equipped with a rollover sensor the side and/or curtain airbags and pretensioners on both sides of the vehicle may deploy if a rollover or possible rollover is detected.

The side airbags are not designed to deploy in all side impact or rollover situations.

### WARNING

To reduce the risk of serious injury or death from an inflating side airbag, take the following precautions:

- Seat belts must be worn at all times to help keep occupants positioned properly.
- Do not allow passengers to lean their heads or bodies onto doors, put their arms on the doors, stretch their arms out of the window, or place objects between the doors and seats.
- Hold the steering wheel at the 9 o'clock and 3 o'clock positions, to minimize the risk of injuries to your hands and arms.
- Do not use any accessory seat covers. This could reduce or prevent the effectiveness of the system.
- Do not hang other objects except clothes. In an accident it may cause vehicle damage or personal injury especially when airbag is inflated.
- Do not place any objects over the airbag or between the airbag and yourself. Also, do not attach any objects around the area the airbag inflates such as the door, side door glass, front and rear pillar.
- Do not place any objects between the door and the seat. They may become dangerous projectiles if the side airbag inflates.
- Do not install any accessories on the side or near the side airbags.
- Do not impact the doors when the Start/Stop button is in the ON or START position as this may cause the side airbags to inflate.

- If the seat or seat cover is damaged, have the system serviced by an authorized HYUNDAI dealer.

### Curtain airbags



Curtain airbags are located along both sides of the roof rails above the front and rear doors.

They are designed to help protect the heads of the front seat occupants and the rear outboard seat occupants in certain side impact collisions.

The curtain airbags are designed to deploy during certain side impact collisions, depending on the crash severity.

For vehicles equipped with a rollover sensor the side and/or curtain airbags and pretensioners on both sides of the vehicle may deploy if a rollover or possible rollover is detected.

The curtain airbags are not designed to deploy in all side impact or rollover situations.

### WARNING

To reduce the risk of serious injury or death from an inflating curtain airbag, take the following precautions:

- All occupants must wear seat belts at all times to help keep occupants positioned properly.
- Properly secure Child Restraint System as far away from the door as possible.
- Do not place any objects over the airbag. Also, do not attach any objects around the area the airbag inflates such as the door, side door glass, front and rear pillar, roof side rail.
- Do not hang other objects except clothes, especially hard or breakable objects.

In an accident, it may cause vehicle damage or personal injury.

- Do not allow passengers to lean their heads or bodies onto doors, put their arms on the doors, stretch their arms out of the window, or place objects between the doors and seats.
- Do not attempt to open or repair the side curtain airbags yourself. If necessary, have the airbag inspected by an authorized HYUNDAI dealer.

## How does the Airbags System Operate?

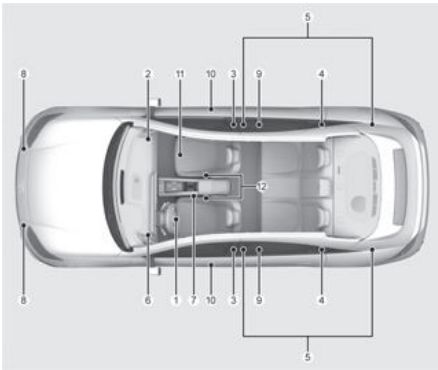

The SRS consists of the following components:

- (1) Driver's front airbag module
- (2) Passenger's front airbag module
- (3) Side airbag modules
- (4) Curtain airbag modules
- (5) Retractor pretensioner
- (6) Airbag warning light
- (7) SRS control module (SRSCM)/Rollover sensor
- (8) Front impact sensors
- (9) Side impact sensors (acceleration)
- (10) Side impact sensors (pressure)
- (11) Occupant classification system
- (12) Driver's and front passenger's seat belt buckle sensors.

The SRSCM (Supplemental Restraint System Control Module) continually monitors all SRS components while the Start/Stop button is ON to determine if a crash impact is severe enough to require airbag deployment or pretensioner seat belt deployment.

## SRS warning light



The SRS (Supplemental Restraint System) airbag warning light on the instrument cluster the airbag symbol depicted in the illustration. The system checks the airbag electrical system for malfunctions. The light indicates that there is a potential problem with your airbag system, which could include your side and/or curtain airbags used for rollover protection.

### **WARNING**

If your SRS malfunctions, the airbag may not inflate properly during an accident increasing the risk of serious injury or death.

If any of the following conditions occur, your SRS is malfunctioning:

- The light does not turn on for about 3-6 seconds when the Start/Stop button is in the ON position.
- The light stays on after illuminating for about three to six seconds.
- The light comes on while the vehicle is in motion.
- The light blinks when the **READY** (ready indicator) is displayed on the instrument cluster.

Have an authorized HYUNDAI dealer inspect the SRS as soon as possible if any of these conditions occur.

During a moderate to severe frontal collision, sensors will detect the vehicle's rapid deceleration. If the rate of deceleration is high enough, the control unit will inflate the front airbags, at the time and with the force needed.

The front airbags help protect the driver and front passenger by responding to frontal impacts in which seat belts alone cannot provide adequate restraint. When needed, the side airbags help provide protection in the event of a side impact or rollover by supporting the side upper body area.

- Airbags are activated (able to inflate if necessary) only when the Start/Stop button is in the ON or START position, and it can be activated within about 3 minutes after the vehicle is turned off.
- Airbags inflate in the event of certain frontal or side collisions to help protect the occupants from serious physical injury.
- Generally, airbags are designed to inflate based upon the severity of a collision, its direction, or etc. These two factors determine whether the sensors produce an electronic deployment/inflation signal.
- The front airbags will completely inflate and deflate in an instant. It is virtually impossible for you to see the airbags inflate during an accident. It is much more likely that you will simply see the deflated airbags hanging out of their storage compartments after the collision.
- In addition to inflating in serious side collisions, vehicles equipped with a rollover sensor, side and/or curtain airbags will inflate if the sensing system detects a rollover.

When a rollover is detected, curtain airbags will remain inflated longer to help provide protection from ejection, especially when used in conjunction with the seat belts. (if equipped with a rollover sensor)

- To help provide protection, the airbags must inflate rapidly. The speed of airbag inflation is a consequence of extremely short time in which to inflate the airbag between the occupant and the vehicle structures before the occupant impacts those structures. This speed of inflation reduces the risk of serious or life-threatening injuries and is thus a necessary part of airbag design.

However, the rapid airbag inflation can also cause injuries which can include facial abrasions, bruises and broken bones because the inflation speed also causes the airbags to expand with a great deal of force.

- There are even circumstances under which contact with the airbag can cause fatal injuries, especially if the occupant is positioned excessively close to the airbag.

You can take steps to reduce the risk of being injured by an inflating airbag. The greatest risk is sitting too close to the airbag. An airbag needs about 10 in. (25 cm) of space to inflate. NHTSA recommends that drivers allow at least 10 in. (25 cm) between the center of the steering wheel and the chest.

### WARNING

To reduce the risk of serious injury or death from an inflating airbag, take the following precautions:

- NEVER place a child restraint in the front passenger seat.  
Always properly restrain children under age 13 in the rear seats of the vehicle.
- Adjust the front passenger's and driver's seats as far to the rear as possible while allowing you to maintain full control of the vehicle.
- Hold the steering wheel with hands at the 9 o'clock and 3 o'clock positions.

- Never place anything or anyone between the airbag and the seat occupant.
- Do not allow the front passenger to place their feet or legs on the dashboard.

Driver's front airbag (1)



When the SRSCM detects a sufficiently severe impact to the front of the vehicle, it will automatically deploy the front airbags.

Driver's front airbag (2)



Upon deployment, tear seam molded directly into the pad cover will separate under pressure from the expansion of the airbags. Further opening of the covers allows full inflation of the airbags.

A fully inflated airbag, in combination with a properly worn seat belt, slows the driver's or the front passenger's forward motion, reducing the risk of head and chest injury.

Driver's front airbag (3)



Passenger's front airbag



After complete inflation, the airbag immediately starts deflating, enabling the driver to maintain forward visibility and the ability to steer or operate other controls.



### WARNING

To prevent objects from becoming dangerous projectiles when the passenger's airbag inflates:

- Do not install or place any objects (drink holder, CD holder, stickers, etc.) on the front passenger's panel above the glove box where the passenger's airbag is located.
- Do not install a container of liquid air freshener near the instrument cluster or on the instrument panel surface.

### What to Expect After an Airbag Inflates

After a frontal or side airbag inflates, it will deflate very quickly. Airbag inflation will not prevent the driver from seeing out of the windshield or being able to steer. Curtain airbags may remain partially inflated for some time after they deploy.

### WARNING

After an airbag inflates, take the following precautions:

- Open your windows and doors as soon as possible after impact to reduce prolonged exposure to the smoke and powder released by the inflating airbag.
- Do not touch the airbag storage area's internal components immediately after an airbag has inflated. The parts that come into contact with an inflating airbag may be very hot.
- Always wash exposed skin areas thoroughly with cold water and mild soap.
- Have an authorized HYUNDAI dealer replaced the airbag immediately after deployment. Airbags are designed to be used only once.

### Noise and smoke from inflating airbag

When the airbags inflate, they make a loud noise and may produce smoke and powder in the air inside of the vehicle. This is normal and is a result of the ignition of the airbag inflator. After the airbag inflates, you may feel substantial discomfort in breathing because of the contact of your chest with both the seat belt and the airbag, as well as from breathing the smoke and powder. The powder may aggravate asthma for some people. If you experience breathing problems after an airbag deployment, seek medical attention immediately.

Though the smoke and powder are nontoxic, they may cause irritation to the skin, eyes, nose, throat, etc. If this is the case, wash and rinse with cold water immediately and seek medical attention if the symptoms persist.

### Occupant Classification System (OCS)



Your vehicle is equipped with an Occupant Classification System (OCS) in the front passenger's seat.

### **Main components of the Occupant Classification System**

- A detection device located within the front passenger seat cushion.
- Electronic system to help determine whether the passenger airbag systems should be activated or deactivated.
- An indicator light located on the overhead console which illuminates the words “PASSENGER AIRBAG OFF” indicating the front passenger airbag system is deactivated.
- The instrument cluster airbag indicator light is interconnected with the OCS.

The OCS is designed to help detect the presence of a properly-seated front passenger and determine if the passenger's front airbag should be enabled (may inflate) or not.

The purpose is to help reduce the risk of injury or death from an inflating airbag to certain front passenger seat occupants, such as children, by requiring the airbag to be automatically turned off.

For example, if a child restraint of the type specified in the regulations is on the seat, the occupant classification sensor can detect it and cause the airbag to turn off.

Front passenger seat adult occupants who are properly seated and wearing the seat belt properly, should not cause the passenger airbag to be automatically turned off. For smaller adults it may turn off, however, if the occupant does not sit in the seat properly (for example, by not sitting upright, by sitting on the edge of the seat, or by otherwise being out of position), this could cause the sensor to turn the airbag off.

You will find the “PASSENGER AIRBAG OFF” indicator on the overhead console panel. This system detects the conditions 1-4 in the following table and activates or deactivates the front passenger airbag based on these conditions.

Always be sure that you and all vehicle occupants are seated properly and

wearing the seat belt properly for the most effective protection by the airbag and the seat belt.

The OCS may not function properly if the passenger takes actions which can affect the classification system. These include:

- Failing to sit in an upright position.
- Leaning against the door or center console.
- Sitting towards the sides of the front of the seat.
- Putting their legs on the dashboard or resting them on other locations which reduce the passenger weight on the front seat.
- Wearing the seat belt improperly.
- Reclining the seatback.
- Wearing thick clothing like ski wear or hip protection wear.
- Putting an additional thick cushion on the seat.
- Putting electrical devices (for example, notebook, satellite radio) on the seat with inverter charging.

### Condition and operation in the front passenger Occupant Classification System

Condition Detected by the Occupant Classification System	Indicator/Warning Light		Devices
	"PASSENGER AIRBAG OFF" Indicator Light	SRS Warning Light	Front Passenger Airbag
Adult *1	Off	Off	Activated
Infant or child under 12 months old *4 with a child restraint system *2*3	On	Off	Deactivated
Unoccupied	On	Off	Deactivated
Malfunction in the system	Off	On	Activated

\*1 The system judges a person of adult size as an adult. When a smaller adult sits in the front passenger seat, the system may recognize him/her as a child depending on his/her physique and posture.

\*2 Do not allow children to ride in the front passenger seat. When a larger child who has outgrown a child restraint system sits in the front passenger seat, the system may recognize him/her as an adult depending upon his/her physique or sitting position.

\*3 Never install a child restraint system on the front passenger seat.

\*4 The PASSENGER AIRBAG "OFF" indicator may turn on or off when a child above 12 months to 12 years old (with or without child restraint system) sits in the front passenger seat. This is a normal condition.

**⚠ WARNING**

Riding in an improper position or placing weight on the front passenger's seat when it is unoccupied by a passenger adversely affects the OCS. To reduce the risk of serious injury or death:

- NEVER put a heavy load in the front seat or seatback pocket, or hang any items on the front passenger seat.



- NEVER place your feet on the front passenger seatback.



- NEVER sit with your hips shifted towards the front of the seat.



- NEVER ride with the seatback reclined when the vehicle is moving.



- NEVER place your feet or legs on the dashboard.



- NEVER lean on the door or center console or sit on one side of the front passenger seat.



- Do not sit on the passenger seat wearing heavily padded clothes such as ski wear or hip protector.



- Do not use car seat accessories such as thick blankets and cushions which cover the car seat surface.



- Do not place electronic devices such as laptops, DVD player, or conductive materials such as water bottles on the passenger seat. Do not use electronic devices such as laptops and satellite radios which use inverter chargers.



- If large quantity of liquid has been spilled on the passenger seat, the airbag warning light may illuminate or malfunction. Therefore, make sure the seat has been completely dried before driving the vehicle.



- Do not place sharp objects on the front passenger seat. These may damage the occupant detection system, if they puncture the seat cushion.
- Do not place any items under the front passenger seat.

- When changing or replacing the seat only use Genuine Hyundai Parts. The OCS has been developed based on using original HYUNDAI car seats only. Altering or changing the authentic parts may result in system malfunction and increase risk of injury when in collision. Any of the above could interfere with the proper operation of the OCS sensor thereby increasing the risk of an injury in an accident.
- 

### Proper seated position for OCS



If the “PASSENGER AIRBAG OFF” indicator is on when an adult is seated in the front passenger seat, place the Start/Stop button in the OFF position and ask the passenger to sit properly (sitting upright with the seat back in an upright position, centered on the seat cushion with their seat belt on, legs comfortably extended and their feet on the floor). Restart the vehicle and have the person remain in that position. This will allow the system to detect the person and to enable the passenger airbag. If the “PASSENGER AIRBAG OFF” indicator is still on, ask the passenger to move to the rear seat.

### WARNING

NEVER allow an adult passenger to ride in the front passenger seat when the “PASSENGER AIRBAG OFF” indicator is illuminated. During a collision, the airbag will not inflate if the indicator is illuminated. Have your passenger reposition themselves in the seat. If the “PASSENGER AIRBAG OFF” indicator remains illuminated after the passenger repositions themselves properly and the vehicle is restarted, have the passenger move to the rear seat because the airbag will not inflate.

---

### NOTICE

The “PASSENGER AIRBAG OFF” indicator generally illuminates for about 4 seconds after the Start/Stop button is in the ON or START position. But, if the Start/Stop button is pressed to the ON or START position within 3 minutes after the vehicle is turned OFF, the indicator does not illuminate. If the front passenger seat is occupied, the OCS will then classify the front passenger after several more seconds.

---

### **Do not install a Child Restraint System on the Front Passenger's Seat**



Even though your vehicle is equipped with the OCS, never install a child restraint in the front passenger's seat. An inflating airbag can forcefully strike a child or child restraint resulting in serious or fatal injury.

#### **! WARNING**

NEVER use a rearward facing Child Restraint on a seat protected by an ACTIVE AIRBAG in front of it, DEATH or SERIOUS INJURY to the CHILD can occur.

### **Why didn't My Airbag Go Off in a Collision?**

There are certain types of accidents in which the airbag would not be expected to provide additional protection. These include rear impacts, second or third collisions in multiple impact accidents, as well as low speed impacts. Damage to the vehicle indicates collision energy absorption, and is not an indicator of whether or not an airbag should have inflated.

### **Airbag collision sensors**

#### **! WARNING**

To reduce the risk of an airbag deploying unexpectedly and causing serious injury or death:

- Do not hit or allow any objects to impact the locations where airbags or sensors are installed.
- Do not perform maintenance on or around the airbag sensors. If the location or angle of the sensors is altered, the airbags may deploy when they should not or may not deploy when they should.
- Installing bumper guards with non-genuine Hyundai parts may adversely affect the collision and airbag deployment performance.  
To ensure correct function of the airbag system, have the bumper replaced with genuine Hyundai part specified for your vehicle.
- Press the Start/Stop button to the OFF or ACC position and wait for 3 minutes when the vehicle is being towed to prevent inadvertent airbag deployment.
- Have all airbag repairs conducted by an authorized HYUNDAI dealer.

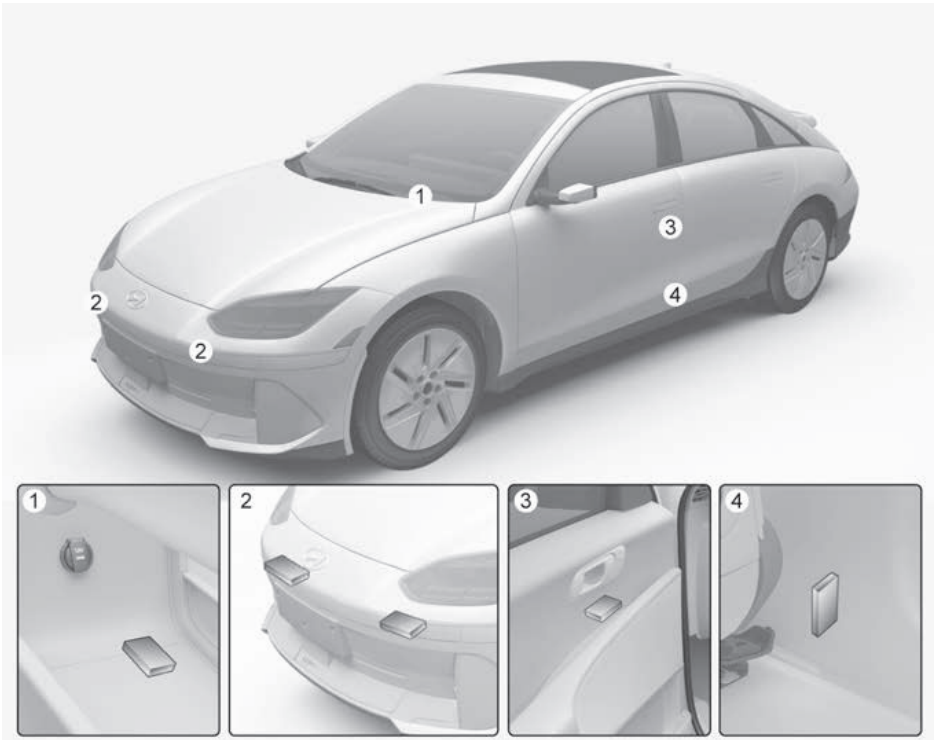

- (1) SRS control module/Rollover sensor
- (2) Front impact sensor
- (3) Side impact sensor (Pressure)
- (4) Side impact sensor (Acceleration)



## ***Airbag inflation conditions***

### **Front airbags**

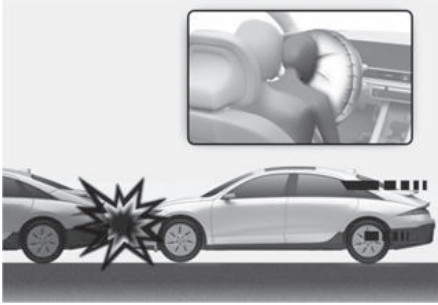

Front airbags are designed to inflate in a frontal collision depending on the severity of impact of the front collision.

### **Side and curtain airbags**



Side and curtain airbags are designed to inflate when an impact is detected by side collision sensors depending on the severity of impact resulting from a side collision.

Although the driver and front passenger airbags are designed to inflate in frontal collisions, they also may inflate in other types of collisions if the front impact sensors detect a sufficient impact. Side and curtain airbags are designed to inflate in side impact collisions, but they may inflate in other collisions if the side impact sensors detect a sufficient impact.

Also, the side and curtain airbags are designed to inflate when a rollover is detected by a rollover sensor.

If the vehicle chassis is impacted by bumps or objects on unimproved roads, the airbags may deploy. Drive carefully on unimproved roads or on surfaces not designed for vehicle traffic to prevent unintended airbag deployment.

### ***Airbag non-inflation conditions***



In certain low-speed collisions the airbags may not deploy. The airbags are designed not to deploy in such cases because they may not provide benefits beyond the protection of the seat belts.

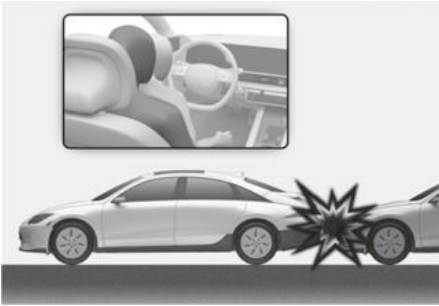

Front airbags are not designed to inflate in rear collisions, because occupants are moved backward by the force of the impact. In this case, inflated airbags would not provide any additional benefit.

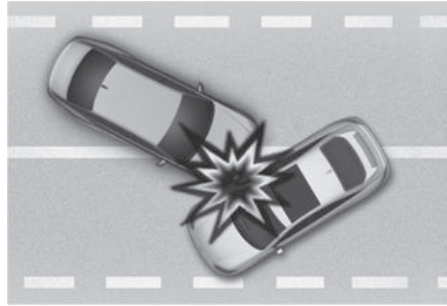

In an angled collision, the force of impact may direct the occupants in a direction where the airbags would not be able to provide any additional benefit, and thus the sensors may not deploy any airbags.



Front airbags may not inflate in side impact collisions, because occupants move in the direction of the collision, and thus in side impacts, front airbag deployment would not provide additional occupant protection.

However, side and curtain airbags may inflate depending on the severity of impact.



Just before impact, drivers often brake heavily. Such heavy braking lowers the front portion of the vehicle causing it to “ride” under a vehicle with a higher ground clearance. Airbags may not inflate in this “underride” situation because deceleration forces that are detected by sensors may be significantly reduced by such “underride” collisions.

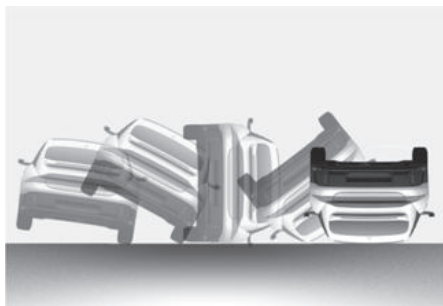

Front airbags may not inflate in rollover accidents because front airbag deployment would not provide additional occupant protection.

The side and curtain airbags may inflate in a rollover situation, when it is detected by the rollover sensor.

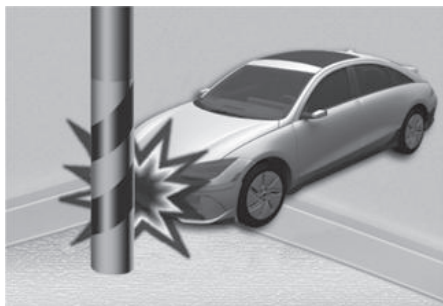

Airbags may not inflate if the vehicle collides with objects such as utility poles or trees, where the point of impact is concentrated and the collision energy is absorbed by the vehicle structure.

## SRS Care

The SRS is virtually maintenance-free and there are no parts you can safely service by yourself. If the SRS airbag warning light does not illuminate when the Start/Stop button is in the ON position, or continuously remains on, have the system be immediately inspected by an authorized HYUNDAI dealer.

Any work on the SRS system, such as removing, installing, repairing, or any work on the steering wheel, the front passenger's panel, front seats and roof rails be performed by an authorized HYUNDAI dealer. Improper handling of the SRS system may result in serious personal injury.

### WARNING

To reduce the risk of serious injury or death take the following precautions:

- Do not attempt to modify or disconnect the SRS components or wiring, including the addition of any kind of badges to the pad covers or modifications to the body structure.
- Do not place objects over or near the airbag modules on the steering wheel, instrument panel, and the front passenger's panel above the glove box.
- Clean the airbag pad covers with a soft cloth moistened with plain water. Solvents or cleaners could adversely affect the airbag covers and proper deployment of the system.
- Have the inflated airbags replaced by an authorized HYUNDAI dealer.
- If components of the airbag system must be discarded, or if the vehicle must be scrapped, certain safety precautions must be observed. Consult an authorized HYUNDAI dealer for the necessary information. Failure to follow these precautions could increase the risk of personal injury.

## Additional Safety Precautions

**Passengers should not move out of or change seats while the vehicle is moving.** A passenger who is not wearing a seat belt during a crash or emergency stop can be thrown against the inside of the vehicle, against other occupants, or be ejected from the vehicle.

**Do not use any accessories on seat belts.**

Devices claiming to improve occupant comfort or reposition the seat belt can reduce the protection provided by the seat belt and increase the chance of serious injury in a crash.

**Do not modify the front seats.**

Modification of the front seats could interfere with the operation of the supplemental restraint system sensing components or side airbags.

**Do not place items under the front seats.**

Placing items under the front seats could interfere with the operation of the supplemental restraint system sensing components and wiring harnesses.

**Do not cause impact to the doors.**

Impact to the doors when the Start/Stop button is in the ON or START position may cause the airbags to inflate.

**Modifications to accommodate**

**disabilities.** If you require modification to your vehicle to accommodate a disability, contact the HYUNDAI Customer Connect Center at 800-633-5151.

### ***Adding equipment to or modifying your airbag equipped vehicle***

If you modify your vehicle by changing your vehicle's frame, bumper system, front end or side sheet metal or ride height, this may affect the operation of your vehicle's airbag system.

## Airbag Warning Labels



Airbag warning labels, required by the U.S. National Highway Traffic Safety Administration (NHTSA), are attached to alert the driver and passengers of potential risks of the airbag system. Be sure to read all of the information about the airbags that are installed on your vehicle in this Owners Manual.

# 4. Instrument Cluster

Instrument Cluster.....	4-2
Instrument Cluster Control .....	4-3
Gauges and Meters .....	4-3
Power/Charge Gauge .....	4-3
State of Charge (SOC) Gauge for High Voltage Battery.....	4-4
Gear Shift Indicator .....	4-6
Warning and Indicator Lights.....	4-6
Cluster Display Messages.....	4-17
Cluster Display .....	4-24
Cluster Display Control.....	4-24
View Modes .....	4-24
Vehicle settings (infotainment system) .....	4-27
Setting Your Vehicle .....	4-28

## Instrument Cluster

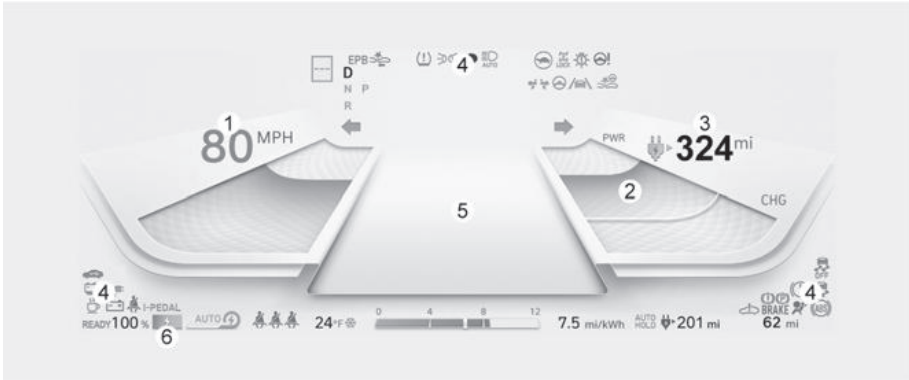

The actual cluster in the vehicle may differ from the illustration. For more information, refer to the “Gauges and Meters” section in this chapter.

- (1) Speedometer
- (2) Power/Charge gauge
- (3) Distance to empty
- (4) Warning and indicator lights
- (5) Cluster display
- (6) Battery SOC (State of Charge) gauge

### **i** Information

SNOW/NORMAL/ECO/SPORT mode by pressing the drive mode button will change the main theme of the instrument cluster.

## Instrument Cluster Control

### Instrument panel illumination

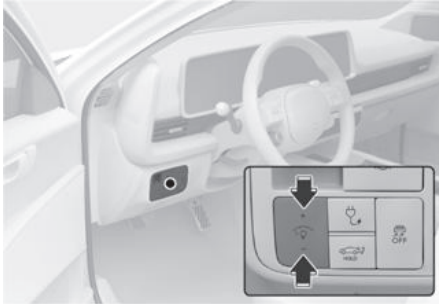

When the vehicle's parking lights or headlights are on, press the illumination control switch to adjust the brightness of the instrument panel illumination.

When pressing the illumination control switch, the interior illumination intensity is also adjusted.

### WARNING

Never adjust the instrument panel illumination while driving to prevent death, serious injury, or vehicle damage.

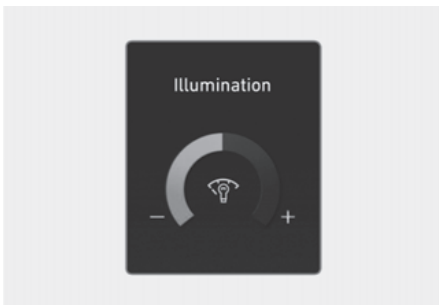

- The brightness of the instrument panel illumination is displayed.
- When the brightness setting reaches either the minimum or maximum level, a chime sounds.

## Gauges and Meters

### Speedometer



The speedometer indicates the speed of the vehicle and is calibrated in mi. per hour (MPH).

### Power/Charge Gauge

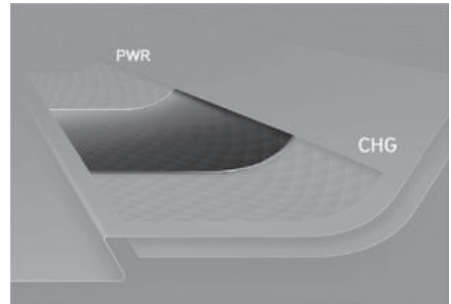

The Power/Charge gauge shows the energy consumption rate of the vehicle and the charge/discharge status of the regenerative brakes.

#### • POWER:

The discharging status of the electric motor is shown when the vehicle is accelerating or driving on an uphill road. As the electric energy discharged increases, the gauge level also increases.

- CHARGE :

The charging status of the electric motor is shown when the vehicle is decelerating or driving on a downhill road (being charged by the regenerative brakes). As more electric energy charges, the lower the gauge level.

## State of Charge (SOC) Gauge for High Voltage Battery



- The SOC gauge shows the charging status of the high voltage battery.
- The low percentage number on the indicator indicates that there is not enough energy in the high voltage battery. 100 % indicates that the high voltage battery is fully charged.
- When driving on highways, make sure to check in advance if the high voltage battery is charged enough.



1. When the remaining battery is lower than 10 % on the SOC gauge, the High

Voltage Battery Level () warning light illuminates, to alert you of the battery level.

2. When the High Voltage Battery Level

() warning light illuminates, the vehicle can drive an additional 18-25 mi. (30-40 km) depending on the driving speed, heater/air conditioner, weather, driving style, and other factors. Charging is required.

### NOTICE

When the high voltage battery level is low, the Power Down () indicator light illuminates and the vehicle power is limited.

Charge the battery immediately since your vehicle may not be driven, or may roll back on a slope with the indicator light illuminated.



### Outside temperature gauge



The temperature reads in Fahrenheit or Celsius depending on the units selected from the Settings menu in the infotainment system. The temperature indicated on the instrument cluster may not change as quickly as the outside temperature.

Select: **Setup > General > Units > Temperature Unit > °F/°C**

Both the temperature unit on the instrument cluster and climate control screen is changed.

#### *i* Information

The infotainment system may change after software updates. For more information, refer to the user's manual provided in the infotainment system and the quick reference guide.

### Odometer

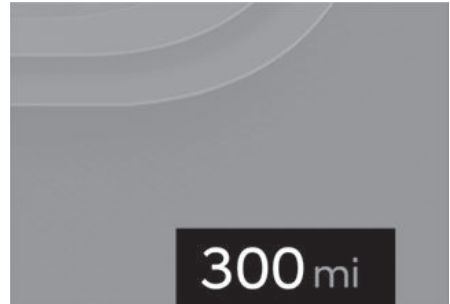

The odometer indicates the total distance that the vehicle has been driven and should be used to determine when periodic maintenance is required.

### Distance to empty

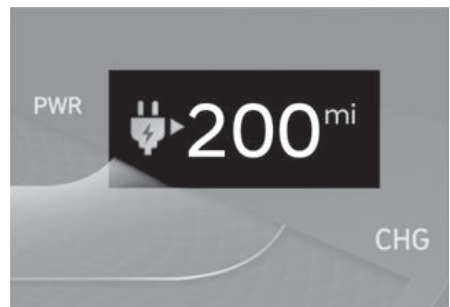

The distance to empty is the estimated distance the vehicle can be driven with the remaining electric energy.

For more information, refer to the "Factors affecting the distance to empty" section in chapter 1.

#### *i* Information

- The distance to empty may differ from the actual driving distance because it is only an estimate as it is an estimate of the available driving distance.
- The distance to empty may differ significantly based on driving conditions, driving habits, and condition of the vehicle.

- If the vehicle is not on level ground or the battery power has been interrupted, the distance to empty function may not operate correctly.

### Gear Shift Indicator



The Gear Shift Indicator indicates the current gear or P (Park).

### Regenerative braking level indicator



The selected regenerative braking level is displayed on the instrument cluster. Also, the Smart Regenerative System's operation status is displayed.

For more information, refer to the "Regenerative Braking System (Paddle Shifter)" section in chapter 6.

## Warning and Indicator Lights

### *i* Information

Make sure that all warning lights are OFF after starting the vehicle. If any light is still ON, this indicates a situation that needs attention.

---

### *Ready Indicator Light*

# READY

#### **This indicator illuminates:**

When the vehicle is ready to be driven.

- ON: Normal driving is possible.
- OFF: Normal driving is not possible, or a problem has occurred.
- Blinking: Emergency driving.

When the **READY** indicator goes off or blinks, there is a problem with the system. In this case, have your vehicle inspected by an authorized HYUNDAI dealer.

### Service Warning Light



#### This warning light illuminates:

- When the Start/Stop button is in the ON position. The Service warning light illuminates for 3 seconds and then goes off.
- When there is a problem with related parts of the electric vehicle control system, such as sensors, etc.

When the warning light illuminates while driving, or does not go off after starting the vehicle, have your vehicle inspected by an authorized HYUNDAI dealer.

### Power Down Indicator Light



#### This indicator light illuminates:

When the power is limited for the safety of the high-powered parts of an electric vehicle. The power is limited for the following reasons:

- The high voltage battery level is too low or voltage is decreasing
- The temperature of the high voltage battery is too high or too low
- The temperature of the motor is high

### NOTICE

- Do not accelerate or start the vehicle suddenly when the power down indicator light is illuminated.
- When the power is limited for the safety of high-powered parts of an electric vehicle, the power down indicator light illuminates. Your vehicle may not be driven, or may roll back on a slope with the indicator light illuminated due to the limitation of vehicle power.

### *i* Information

Unless both the Service Warning Light and Power Down Indicator Light illuminate at the same time, it is not a failure.

### Charging Connector Indicator Light



This warning light indicates the connection status of the charging connector. When the charging connector is connected to the vehicle, the green light illuminates for about 1 minute.

### **High Voltage Battery Level Warning Light**



#### **This warning light illuminates:**

When the high voltage battery level is low.

Charge the high voltage battery as soon as possible.

### **Seat Belt Warning Light**



This warning light informs the driver that the seat belt is not fastened.

For more information, refer to the “Seat Belts” section in chapter 3.

### **Airbag Warning Light**



#### **This warning light illuminates:**

- When the Start/Stop button is in the ON position. The Airbag warning light illuminates for 3-6 seconds and then goes off.
- When there is a malfunction with the SRS.

If the Airbag warning light remains illuminated while driving, have the vehicle inspected by an authorized HYUNDAI dealer.

### **Regenerative Brake Warning Light**



#### **This warning light illuminates:**

When the regenerative brake does not operate and the brake does not perform well. This causes the Brake Warning light (red) and Regenerative Parking Brake Warning Light (yellow) to illuminate simultaneously.

In this case, drive safely and have your vehicle inspected by an authorized HYUNDAI dealer.

The operation of the brake pedal may be more difficult than normal and the braking distance can increase.

## **Parking Brake and Brake Fluid Warning Light**



### **This warning light illuminates:**

When the Start/Stop button is in the ON position. The Parking Brake warning light illuminates for about 3 seconds and then goes off once the parking brake is released.

- Whenever the parking brake is applied.
- Whenever the brake fluid level in the reservoir is low.
  - If the warning light illuminates with the parking brake released, it indicates the brake fluid level in the reservoir is low.
- When the regenerative brake does not operate.

### **If the brake fluid level in the reservoir is low:**

1. Drive carefully to the nearest safe location and stop your vehicle.
2. With the motor stopped, check the brake fluid level immediately and add fluid as required (For more information, refer to the “Brake Fluid” section in chapter 9). After adding brake fluid, check all brake components for fluid leaks. If a brake fluid leak is found, or if the warning light remains on, or if the brakes do not operate properly, do not drive the vehicle. Have the vehicle inspected by an authorized HYUNDAI dealer.

## **Dual-diagonal braking system**

Your vehicle is equipped with the dual-diagonal braking system. This means you still have braking on two wheels even if one of the dual systems fails.

With only one of the dual systems working, more than normal pedal travel and greater pedal force are required to stop the vehicle.

Also, the vehicle does not stop in a short distance if only a portion of the braking system is working.

### **! WARNING**

If the Parking Brake and Brake Fluid warning light illuminates with the parking brake released, it indicates that the brake fluid level is low.

Have the vehicle inspected by an authorized HYUNDAI dealer.

## **Anti-lock Brake System (ABS) Warning Light**



### **This warning light illuminates:**

- When the Start/Stop button is in the ON position. The ABS warning light illuminates for about 3 seconds and then goes off.
- Whenever there is a malfunction with the ABS.

The hydraulic braking system still operates even if there is a malfunction with the ABS.

If the ABS warning light remains illuminated while driving, have the vehicle inspected by an authorized HYUNDAI dealer.

### **Electronic Brake Force Distribution (EBD) System Warning Light**



When the ABS warning and Parking Brake warning lights are on simultaneously, it may indicate a problem with the Electronic Brake Force Distribution system.

If both the ABS warning light and the Parking Brake warning light remain illuminated while driving, have the vehicle inspected by an authorized HYUNDAI dealer.

#### **! WARNING**

When both ABS and Parking Brake and Brake Fluid warning lights are on, the braking system does not work normally and you may experience an unexpected and dangerous situation during sudden braking. Avoid high speed driving and abrupt braking.

Have the vehicle inspected by an authorized HYUNDAI dealer as soon as possible.

#### **i Information**

When the ABS warning light is on or both ABS and Parking Brake and Brake Fluid warning lights are on, the speedometer, odometer, or tripmeter may not work. Also, the MDPS warning light may illuminate and the steering effort may increase or decrease.

### **Motor Driven Power Steering (MDPS) Warning Light**



**This warning light illuminates:**

- When the Start/Stop button is in the ON position. The Motor Driven Power Steering warning light illuminates for about 3 seconds and then goes off.
- Whenever there is a malfunction with Motor Driven Power Steering.  
If the MDPS warning light remains illuminated while driving, have the vehicle inspected by an authorized HYUNDAI dealer.

### **Master Warning Light**



**This warning light illuminates:**

If a malfunction is detected in any of the following:

- Forward Collision-Avoidance Assist malfunction
- Forward Collision-Avoidance Assist radar blocked
- Blind-Spot Collision-Avoidance Assist malfunction
- Blind-Spot Collision-Avoidance Assist radar blocked
- LED headlight malfunction
- High Beam Assist malfunction
- Smart Cruise Control malfunction
- Smart Cruise Control radar blocked

- Tire Pressure Monitoring System (TPMS) malfunction

If the issue is resolved, the Master Warning Light turns off.

### **Electronic Parking Brake (EPB) Warning Light**

# EPB

**This warning light illuminates:**

- When the Start/Stop button is in the ON position. The EPB warning light illuminates for about 3 seconds and then goes off.
- Whenever there is a malfunction with EPB.

If the EPB warning light remains illuminated while driving, have the vehicle inspected by an authorized HYUNDAI dealer.

### ***i* Information**

The Electronic Parking Brake (EPB) warning light may illuminate when the Electronic Stability Control (ESC) indicator light comes on to indicate that ESC is not working properly. This does not indicate malfunction of EPB.

### **Low Tire Pressure Warning Light**



**This warning light illuminates:**

- When the Start/Stop button is in the ON position. The low tire pressure warning light illuminates for about 3 seconds and then goes off.
- When one or more tires are significantly underinflated. (The location of the underinflated tire appears on the instrument cluster.)

For more information, refer to the “Tire Pressure Monitoring System (TPMS)” section in chapter 8.

**This warning light remains ON after blinking for about 60 seconds, or repeatedly blinks ON and OFF in 3 second intervals:**

When there is a malfunction with the TPMS.

If this occurs, have the vehicle inspected by an authorized HYUNDAI dealer as soon as possible.

For more information, refer to the “Tire Pressure Monitoring System (TPMS)” section in chapter 8.

### **WARNING**

- The TPMS cannot alert you to severe and sudden tire damage caused by external factors.
- If you notice any vehicle instability, immediately take your foot off the accelerator pedal, apply the brakes gradually with light force, and slowly move to a safe position off the road.

### **Driver Attention Warning Light**



#### **This warning light illuminates:**

- When you set the ignition switch to the ON position, the yellow indicator light illuminates for about 3 seconds and then goes off
- [Continuously Yellow] When the front view camera is blocked or Driver Attention Warning is disable/malfunction
- [Blinking Yellow] When the function suggest that the driver take a break

If the yellow warning light is still on even after removing foreign material from the front of the sensor, have the vehicle inspected by an authorized HYUNDAI dealer as soon as possible

For more information, refer to the “Driver Attention Warning (DAW)” section in chapter 7

### **Forward Safety Warning Light**

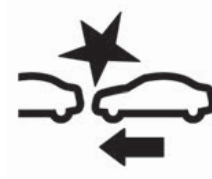

#### **This warning light illuminates:**

- When the Start/Stop button is in the ON position. The Forward Safety warning light illuminates for about 3 seconds and then goes off.
- [Yellow] When Forward Safety is deselected or Forward Collision-Avoidance Assist disable/malfunction
- [Blinking Red] When Forward Safety/Forward Cross-Traffic Safety of Forward Collision-Avoidance Assist is operating

If the yellow warning light is still on even after removing foreign material from the front of the sensors after Forward Safety select in settings, have the vehicle inspected by an authorized HYUNDAI dealer as soon as possible.

For more information, refer to the “Forward Collision-Avoidance Assist (FCA)” section in chapter 7.



## Emergency Steering Warning Light

<sup>+</sup>if equipped



### This indicator light illuminates:

- When you set the Start/Stop button to the ON position, the yellow warning light illuminates for about 3 seconds and then goes off
- [Continuously Yellow] When Forward/Side Safety is deselected or Forward Collision-Avoidance Assist disable/malfunction
- [Blinking Red] When Forward/Side Safety of Forward Collision-Avoidance Assist is operating

If the yellow warning light is still on even after removing foreign material from the front of the sensors after Forward Safety select in settings, have the vehicle inspected by an authorized HYUNDAI dealer as soon as possible.

For more information, refer to the “Forward Collision-Avoidance Assist (FCA)” section in chapter 7.

## Lane Safety Indicator Light



### This indicator light illuminates:

- When you set the ignition switch to the ON position, the yellow indicator light illuminates for about 3 seconds and then goes off
- [Gray] When Lane Keeping Assist operational conditions are not met
- [Continuously Green] When Lane Keeping Assist operational conditions are met
- [Blinking Green] When Lane Keeping Assist is operating
- [Yellow] When Lane Keeping Assist disable/malfunction

If the yellow warning light is still on even after removing foreign material from the front of the sensor after Lane Safety select in settings, have the vehicle inspected by an authorized HYUNDAI dealer as soon as possible.

For more information, refer to the “Lane Keeping Assist (LKA)” section in chapter 7.

### All Wheel Drive (AWD) Warning Light

 if equipped



#### This warning light illuminates:

Whenever a malfunction with the AWD system is detected.

If this occurs frequently, have the vehicle inspected by an authorized HYUNDAI dealer.

For more information, refer to the "All Wheel Drive (AWD)" section in chapter 6.

### LED Headlight Warning Light



#### This warning light illuminates:

- When the Start/Stop button is in the ON position. The LED headlight warning light illuminates for about 3 seconds and then goes off.
- Whenever there is a malfunction with the LED headlight.

If the LED headlight warning light remains illuminated while driving, have the vehicle inspected by an authorized HYUNDAI dealer.

#### This warning light blinks:

Whenever there is a malfunction with a LED headlight related part.

If this occurs, have the vehicle inspected by an authorized HYUNDAI dealer.

### NOTICE

Continuous driving with the LED Headlight warning light on or blinking can reduce LED headlight life.

### Icy Road Warning Light

 if equipped



#### This indicator light illuminates:

To warn the driver the road may be icy.

When the outside temperature on the temperature gauge is below 40 °F (4 °C), a single chime sounds, both the outside temperature gauge and Icy Road Warning indicator blink several times, and then they remain illuminated.

You can activate or deactivate Icy Road Warning function from the Settings menu in the infotainment system.

Select: **Setup > Vehicle > Cluster > Content Selection > Icy Road Warning**

### Information

- If the Icy Road warning light appears while driving, avoid speeding, rapid acceleration, sudden braking, or sharp turning.
- The infotainment system may change after software updates. For more information, refer to the user's manual provided in the infotainment system and the quick reference guide.

**Door open indicator light**

**This indicator light illuminates:**

When any door or trunk is left open.

**⚠ WARNING**

Before driving the vehicle, confirm the door and trunk are fully closed.

**⚠ CAUTION**

The 12 V battery may discharge if you leave the vehicle with the Door Open indicator light illuminated.

**Electronic Stability Control (ESC) Indicator Light**

**This indicator light illuminates:**

- When the Start/Stop button is in the ON position. The Electronic Stability Control indicator light illuminates for about 3 seconds and then goes off.
- Whenever a malfunction with ESC system is detected.

If this occurs, have the vehicle inspected by an authorized HYUNDAI dealer.

**This indicator light blinks:**

While ESC is operating.

For more information, refer to the “Electronic Stability Control (ESC)” section in chapter 6.

**Electronic Stability Control (ESC) OFF Indicator Light**

**This indicator light illuminates:**

- When the Start/Stop button is in the ON position. The Electronic Stability Control indicator light illuminates for about 3 seconds and then goes off.
- When you deactivate ESC system by pressing the ESC OFF button.

For more information, refer to the “Electronic Stability Control (ESC)” section in chapter 6.

**Immobilizer Indicator Light**

**This indicator light illuminates for up to 30 seconds:**

When the vehicle detects the smart key in the vehicle with the Start/Stop button in the ACC or ON position.

- At this time, you can start the vehicle.
- The indicator light goes off after starting the vehicle.

**This indicator light blinks for a few seconds:**

When the smart key is not in the vehicle, you cannot start the vehicle.

**This indicator light illuminates for 2 seconds and goes off:**

If the smart key is in the vehicle and the Start/Stop button is ON, but the vehicle cannot detect the smart key, have the vehicle inspected by an authorized HYUNDAI dealer.

**This indicator light blinks:**

Whenever there is a malfunction with the immobilizer system, have the vehicle inspected by an authorized HYUNDAI dealer.

### ***Turn Signal Indicator Light***



**This indicator light blinks:**

When you operate the turn signal lever.

If any of the following occur, there may be a malfunction with the turn signal system.

- The turn signal indicator light illuminates but does not blink.
- The turn signal indicator light blinks rapidly.
- The turn signal indicator light does not illuminate at all.

If any of these occur, have the vehicle inspected by an authorized HYUNDAI dealer.

### ***High Beam Indicator Light***



**This indicator light illuminates:**

- When the headlights are on and in the high beam position.
- When the turn signal lever is pulled into the Flash-to-Pass position.

### ***Light ON Indicator Light***



**This indicator light illuminates:**

When the Parking lights or headlights are on.

### High Beam Assist Indicator Light



#### This indicator light illuminates:

When the high beam is on with the light switch in the AUTO position.

- [White] When High Beam Assist is ready to operate.
- [Green] When High Beam Assist is operating.

If your vehicle detects oncoming vehicles in front of you, High Beam Assist switches the high beam to low beam automatically.

For more information, refer to the “High Beam Assist (HBA)” section in chapter 5.

### AUTO HOLD Indicator Light



#### This indicator light illuminates:

- [White] When you activate Auto Hold by pressing the AUTO HOLD switch.
- [Green] When you stop the vehicle completely by depressing the brake pedal with Auto Hold activated.
- [Yellow] Whenever a malfunction with the Auto Hold is detected. If the AUTO HOLD indicator light remains YELLOW while driving, have the vehicle inspected by an authorized HYUNDAI dealer.

For more information, refer to the “Electronic Parking Brake (EPB)” section in chapter 6.

## Cluster Display Messages

### Shift to P

This message is displayed if you try to turn off the vehicle without the gear in the P (Park) position.

If this occurs, the Start/Stop button turns to the ACC position.

### Low key battery

When the Start/Stop button is pressed to the OFF position, a message may appear, indicating the internal battery of the Smart Key is low.

Replace the Smart Key battery.

### Press START button while turning wheel

 if equipped

This message is displayed if the steering wheel does not unlock normally when the Start/Stop button is pressed.

You should press the Start/Stop button while turning the steering wheel right and left.

### Press brake pedal to start vehicle

This message is displayed if the Start/Stop button changes to the ACC position twice by pressing the button repeatedly without depressing the brake pedal.

You can start the vehicle by depressing the brake pedal and then pressing the Start/Stop button.

### **Key not in vehicle**

This message is displayed if the smart key is not in the vehicle when you leave the vehicle with the Start/Stop button in the ON or Start position.

Always turn off the vehicle before leaving your vehicle.

### **Key not detected**

This message is displayed if the smart key is not detected when you press the Start/Stop button.

### **Press START button again**

If you cannot start the vehicle after the Start/Stop button is pressed, attempt to start the vehicle by pressing the Start/Stop button again.

If the warning message appears each time you press the Start/Stop button, have the vehicle inspected by an authorized HYUNDAI dealer.

### **Press START button with key**

This message is displayed and the immobilizer indicator blinks if you press the Start/Stop button while the warning message, “Key not detected” appears.

At this time, the immobilizer indicator light blinks.

### **Check BRAKE SWITCH fuse**

This message is displayed if the brake switch fuse is disconnected.

Replace the fuse with a new one before starting the vehicle.

If that is not possible, start the vehicle by pressing the Start/Stop button for 10 seconds in the ACC position.

### **Shift to P to start vehicle**

This message is displayed if you try to start the vehicle in any other position except P (Park).

#### **i Information**

For your safety, You start the vehicle with the gear shifted to P (Park).

---

### **Check smart key system**

This message is displayed when there is a problem with the smart key system. Have the vehicle inspected by an authorized HYUNDAI dealer.

### **Door, Hood, Trunk open indicator**

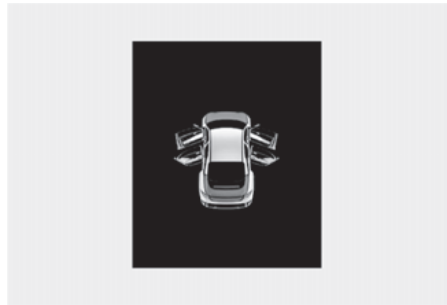

This warning is displayed if any door or hood or trunk is left open. The warning indicates which door is on the cluster display.

#### **⚠ CAUTION**

Before driving the vehicle, confirm the door, hood, and trunk are fully closed. Also, check there are no door, hood, and trunk open warning lights or messages displayed on the instrument cluster.

---

### Low tire pressure



This warning message is displayed if the tire pressure is low. The corresponding tire on the vehicle illuminates.

For more information, refer to the "Tire Pressure Monitoring System (TPMS)" section in chapter 8.

### Lights



This indicator displays which exterior light is selected using the lighting control.

You can activate or deactivate Wiper/Lights display function from the Settings menu in the infotainment system.

Select: **Setup > Vehicle > Cluster > Content Selection > Wiper/Lights Display**

### Wiper



This indicator displays which wiper speed is selected using the wiper control.

You can activate or deactivate Wiper/Lights display function from the Settings menu in the infotainment system.

Select: **Setup > Vehicle > Cluster > Content Selection > Wiper/Lights Display**

### *i* Information

The infotainment system may change after software updates. For more information, refer to the user's manual provided in the infotainment system and the quick reference guide.

### Low washer fluid

This message is displayed if the washer fluid level in the reservoir is nearly empty. Have the washer fluid reservoir refilled.

### Check haptic steering wheel system

**+** if equipped

This message is displayed if there is a problem with the haptic steering wheel system. Have the vehicle inspected by an authorized HYUNDAI dealer.

### **Check headlight LED**

This message is displayed if there is a problem with the LED headlight. Have the vehicle inspected by an authorized HYUNDAI dealer.

### **Shift to P to charge**

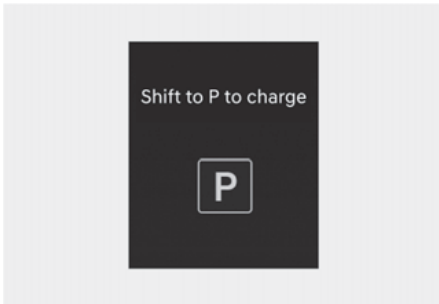

This message is displayed if you connect the charging cable without the gear in the P (Park) position.

Shift to P (Park) before connecting the charging cable.

### **Remaining time**

AC charge

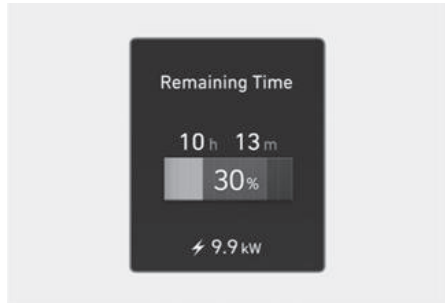

DC charge

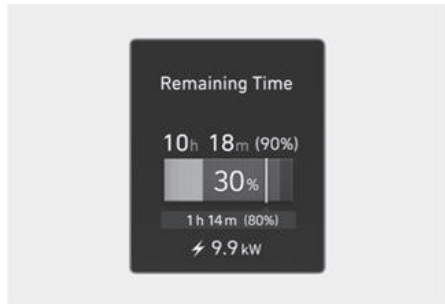

This message is displayed to notify the remaining time to charge the battery to the selected target battery charge level.

### **Unplug vehicle to start**

This message is displayed when you start the vehicle without unplugging the charging cable. Unplug the charging cable, and then turn on the vehicle.

### **Charging door open**

This message is displayed when the vehicle is driven with the charging door opened. Close the charging door and then start driving.



### **Charging stopped. Check the AC/DC charger**

This warning message is displayed when charging is stopped for the following reasons:

- There is a problem with the external AC charger or DC charger
- The external AC charger stops charging
- The charging cable is damaged

In this case, check whether there is any problem with the external AC or DC charger and charging cable.

If the same problem occurs when charging the vehicle with a normally operating AC charger or genuine HYUNDAI portable charger, have your vehicle inspected by an authorized HYUNDAI dealer.

### **Charging stopped. Check the cable connection**

This warning message is displayed when charging is stopped because the charging connector is not correctly connected to the charging inlet

In this case, separate the charging connector and reconnect it and check whether there is any problem (external damage, foreign substances, etc.) with the charging connector and charging inlet.

If the same problem occurs when charging the vehicle with a replaced charging cable or genuine HYUNDAI portable charger, have your vehicle inspected by an authorized HYUNDAI dealer.

### **Check regenerative brakes**

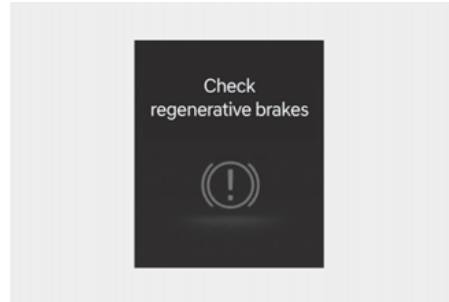

These warning messages are displayed when the regenerative brake system does not work properly.

In this case, have the vehicle inspected by an authorized HYUNDAI dealer.

### **Low EV battery**

When the high voltage battery level reaches below about 20 %, this warning message is displayed.

The High Voltage Battery Level (🔋) warning light illuminates simultaneously.

Charge the high voltage battery immediately.

### **Charge immediately. Power limited**

When the high voltage battery level reaches below about 10 %, this warning message is displayed.

The High Voltage Battery Level (🔋) warning light illuminates simultaneously.

The vehicle's power will be reduced to minimize the energy consumption of the high voltage battery. Charge the battery immediately.

### **Battery discharging due to external electrical devices**

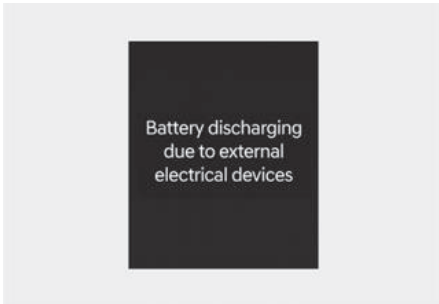

This warning message is displayed when a battery discharge due to excessive current is detected by mounting an unauthorized electrical device such as a black box.

Be careful as it may cause battery discharge problems.

If the warning message is not disappeared after the external electrical device is removed, have the vehicle inspected by an authorized HYUNDAI dealer.

### **Power limited due to low EV battery temperature. Charge battery**

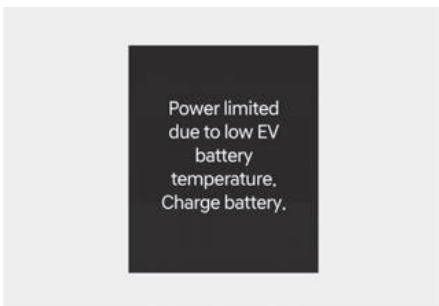

Both warning messages are displayed to protect electric vehicle system when outside temperature is low. If the high voltage battery charging level is low and parked outside in low temperature for a long time, vehicle power may be limited.

Charging the battery before driving helps increase power.

#### **NOTICE**

If these warning messages are still displayed even after the ambient temperature has increased, have the vehicle inspected by an authorized HYUNDAI dealer.

#### **Power limited**

This Indicator light illuminates:

- This warning message is displayed to ensure the safety of high-powered components of electric vehicles. The power is limited for the following reasons:
  - The high voltage battery level is too low or voltage is decreasing
  - The temperature of the high voltage battery is too high or too low
  - The temperature of the motor is high

#### **NOTICE**

- When this warning message is displayed, do not accelerate or start the vehicle suddenly.
- When the power is limited for the safety of high-powered parts of an electric vehicle, the warning message is displayed. Your vehicle may not be driven, or may roll back on a slope with the warning message displayed due to the limitation of vehicle power.

#### **i Information**

Unless both the Service Warning Light and Power Down Indicator Light illuminate at the same time, it is not a failure.

### **Stop vehicle and check power supply**

This warning message is displayed when a failure occurs in the power supply system.

In this case, park the vehicle in a safe location and tow your vehicle to the nearest authorized HYUNDAI dealer and have the vehicle inspected.

### **Check electric vehicle system**

This warning message is displayed when there is a problem with the electric vehicle control system.

Refrain from driving when the warning message is displayed.

In this case, have the vehicle inspected by an authorized HYUNDAI dealer.

### **Check active air flap system**

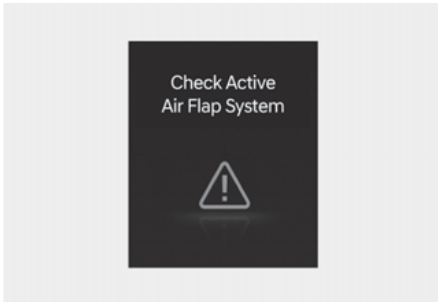

This warning message is displayed in the following situations:

- There is a malfunction with the actuator flap
- There is a malfunction with the actuator air flap controller
- The air flap does not open

When all of the above conditions are fixed, the warning will disappear.

### **Check virtual engine sound system**

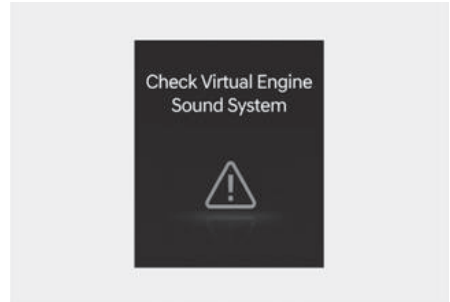

This message is displayed when there is a problem with the Virtual Engine Sound System (VESS).



In this case, have the vehicle inspected by an authorized HYUNDAI dealer.

## Cluster Display

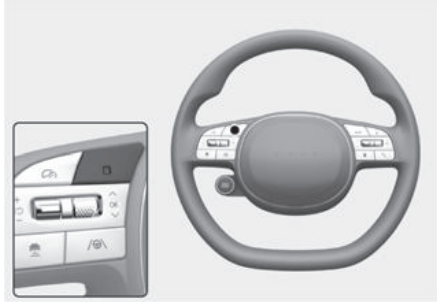
### Cluster Display Control



The cluster display modes can be changed by using the control switches.

Switch	Operation	Function
	Press	MODE button for changing View modes
	Press	UP, DOWN switch for changing items in Utility view and Option menu
OK	Press	SELECT/RESET switch for entering Option menu
	Press and hold	SELECT/RESET switch for retrieving assist information or resetting the selected item

### View Modes

View modes	Explanation
Driving Assist	Driving Assist view displays the status of the vehicle's Driver Assistance systems.
Turn by Turn	Turn By Turn view displays the state of the navigation.
Utility	Utility view displays driving information such as the trip distance, electric energy economy and etc.

The information provided may differ depending on which features are available to your vehicle.

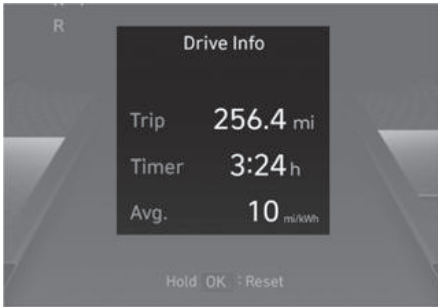

Driving Assist, Turn by Turn, Utility view modes are displayed in the center of the instrument cluster.

### ***Driving Assist view***



The status of Smart Cruise Control, Lane Following Assist, Highway Driving Assist, etc., is displayed when Driving Assist view is selected.

For more information, refer to each function information section in chapter 7.

### ***Turn By Turn (TBT) view***

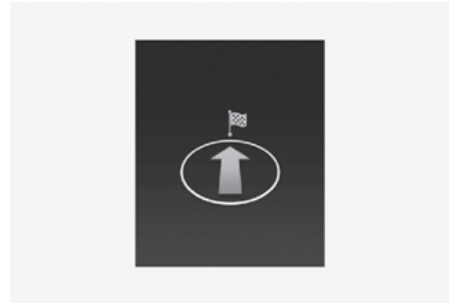

Turn-by-turn navigation, distance/time to destination information is displayed when Turn by Turn view is selected.

### ***Utility view***

In the Utility view, using the  $\wedge$ ,  $\vee$  (UP, DOWN) switch, you may change through items in the following order.

### ***Drive info***

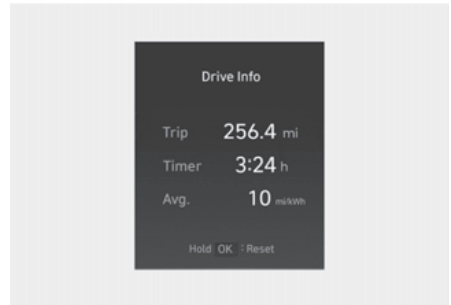

Trip distance, average electric energy economy and total driving time are displayed.

The driver's door is opened after turning off the vehicle or the vehicle is turned on after 3 minutes have passed, the Drive Info screen will reset.

### After Recharging

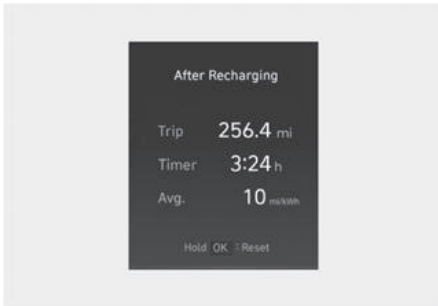

Trip distance, total driving time and average energy consumption after the vehicle has been recharged are displayed. To reset manually, press the OK button on the steering wheel for more than 1 second when 'After Recharging' is displayed.

### Accumulated info

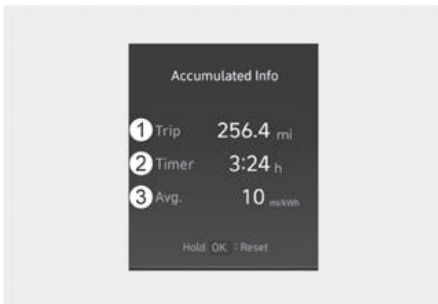

This display shows the accumulated trip distance (1), the average energy consumption (2), and the total driving time (3).

The information is accumulated starting from the last reset.

To manually reset the information, press and hold the OK button when viewing the Accumulated driving info. The trip distance, the average energy consumption, and total driving time will reset simultaneously.

The accumulated driving information will continue to be counted while the vehicle is on (READY indicator is on) (for example,

when the vehicle is in traffic or stopped at a stop light).

### *i* Information

The vehicle must be driven for a minimum of 0.19 mi. (300 m) since the last ignition key cycle before the accumulated driving information is recalculated.

### Tire pressure



The tire pressure of each tire is displayed.

For more information, refer to the “Tire Pressure Monitoring System (TPMS)” section in chapter 8.

### Energy flow/Driving force distribution

**+** if equipped

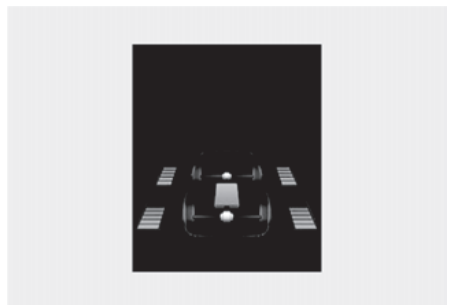

- The electric vehicle system informs the drivers its energy flow in various operating modes.

- The distribution status of the driving power of the front and rear wheels are displayed when Auto AWD mode is activated.

For more information, refer to the "All Wheel Drive (AWD)" section in chapter 6.

### **Additional information display**

#### **Drive info**

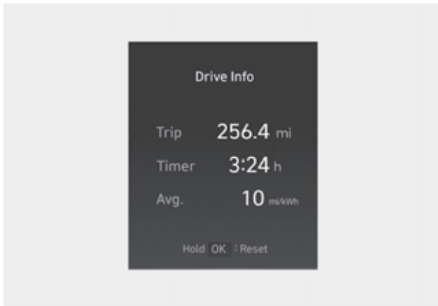

Drive information is displayed for 4 seconds after the vehicle is turned off.

#### **Driving assist information**



The current operation conditions of Smart Cruise Control, Lane Following Assist, Highway Driving Assist, etc., is displayed.

## **Vehicle settings (infotainment system)**

Vehicle Settings in the infotainment system provides user options for the settings including door lock/unlock features, convenience features, driver assistance settings, etc.

#### **Vehicle Settings menu**

- Driver Assistance
- Drive Mode
- EV
- Head-Up Display
- Cluster
- Climate
- Seat
- Lights
- Door
- Convenience

The information provided may differ depending on which functions are available to your vehicle.

#### **⚠ WARNING**

Do not adjust the Vehicle Settings while driving. You may be distracted from the driving task and could crash.

## Setting Your Vehicle

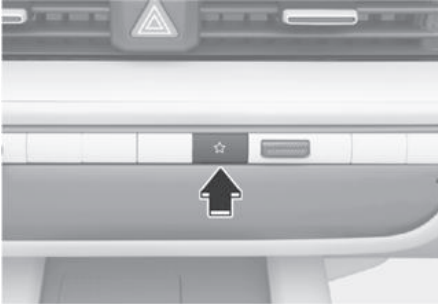

1. Press the Custom (☆) button on the main keyboard.
2. Select **Vehicle** to change the Vehicle Settings.

### *i* Information

The infotainment system may change after software updates. For more information, refer to the user's manual provided in the infotainment system and the quick reference guide.

---



# 5. Convenience Features

Accessing Your Vehicle .....	5-5
Smart key .....	5-5
Immobilizer System .....	5-11
Hyundai Digital Key .....	5-12
Digital key (smartphone) .....	5-12
Digital key (Card key) .....	5-16
Used vehicle/Digital key maintenance .....	5-20
Limitations of the System .....	5-20
Door Locks .....	5-21
Operating Door Unlocks from Outside the Vehicle (Manual type) .....	5-21
Operating Door Unlocks from Outside the Vehicle (Electric type) .....	5-21
Operating Door Locks from Outside the Vehicle (Manual type) .....	5-23
Operating Door Locks from Outside the Vehicle (Electric type) .....	5-23
Operating Door Lock/Unlock from Inside the Vehicle .....	5-26
Automatic Door Lock and Unlock Features .....	5-26
Child-Protector Rear Door Locks .....	5-27
Theft-Alarm System .....	5-28
Rear Occupant Alert (ROA) .....	5-29
System Setting .....	5-29
System Operation .....	5-29
Declaration of Conformity .....	5-31
Integrated Memory System .....	5-31
Storing Memory Positions .....	5-32
Recalling Memory Positions .....	5-32
Resetting the System .....	5-32
Seat Easy Access .....	5-33
Steering Wheel .....	5-34
Motor Driven Power Steering (MDPS) .....	5-34
Tilt/Telescopic Steering .....	5-34
Horn .....	5-35
Heated Steering Wheel .....	5-35
Mirrors .....	5-37
Inside Rearview Mirror .....	5-37
Side View Mirrors .....	5-46
Reverse Parking Aid .....	5-48
Windows .....	5-49

Power Windows.....	5-50
Wide Sunroof.....	5-53
Hood .....	5-56
Opening the Hood.....	5-56
Closing the Hood.....	5-57
Front Trunk.....	5-57
Opening the Front Trunk.....	5-57
Power Trunk .....	5-58
Power Trunk Operating Conditions.....	5-58
Operating the Power Trunk .....	5-59
Resetting the Power Trunk .....	5-61
Emergency Trunk Safety Release.....	5-62
Smart Trunk.....	5-63
Using Smart Trunk.....	5-63
Deactivating smart trunk .....	5-64
Detecting area .....	5-64
Electric Charging Door .....	5-65
Head-up Display .....	5-66
Head-up Display Settings .....	5-66
Head-up Display Information .....	5-67
Precautions while Using the Head-up Display.....	5-67
Over-The-Air Software Update .....	5-68
Downloading Software .....	5-68
Approving Software Update .....	5-68
Preparing Software Update .....	5-69
Updating Software .....	5-69
Lighting.....	5-71
Exterior Lights.....	5-71
Welcome system .....	5-74
Interior Lights .....	5-75
Interior Light AUTO cut .....	5-75
Front lamps .....	5-75
Rear lamps .....	5-75
Vanity Mirror Lamp.....	5-76
Glove Box Lamp.....	5-76

# 5. Convenience Features

Mood Lamp .....	5-76
Front Trunk Lamp.....	5-77
Luggage Compartment Lamp.....	5-78
High Beam Assist (HBA).....	5-78
High Beam Assist Settings .....	5-79
High Beam Assist Operation .....	5-79
High Beam Assist Malfunction and Limitations.....	5-80
Wipers and Washers.....	5-81
Front Windshield Wipers .....	5-82
Front Windshield Washers .....	5-83
Automatic Climate Control System.....	5-84
Climate.....	5-86
Automatic Temperature Control Mode.....	5-86
Manual Temperature Control Mode.....	5-87
System Operation .....	5-95
System Maintenance .....	5-96
Windshield Defrosting and Defogging.....	5-98
To Defog Inside Windshield .....	5-99
To Defrost Outside Windshield .....	5-99
Defogging Logic.....	5-100
Rear Window Defroster .....	5-100
Climate Control Additional Features.....	5-101
A/C Automatic Drying.....	5-101
Auto Defogging System .....	5-101
Auto Dehumidify .....	5-103
Sunroof Inside Air recirculation .....	5-103
Recirculating Air When Washer Fluid Is Used.....	5-103
Recirculating air when entering a tunnel .....	5-104
Automatic Controls Linked to Climate Control Settings (for driver's seat) .....	5-105
Smart Ventilation .....	5-105
Storage Compartment .....	5-105
Center Console Storage .....	5-105
Glove Box.....	5-106
Interior Features .....	5-106
Cup Holder .....	5-106
Sunvisor .....	5-107

Power Outlet.....	5-108
USB Charger .....	5-108
Wireless Smartphone Charging System .....	5-109
Vehicle to Load (V2L) .....	5-111
Clock.....	5-111
Coat Hook .....	5-112
Floor Mat Anchor(s).....	5-112
Infotainment System .....	5-113
USB Port .....	5-113
Antenna .....	5-113
Steering Wheel Remote Controls.....	5-113
Infotainment System.....	5-114
Voice Recognition .....	5-115
Bluetooth® Wireless Technology.....	5-115

## Accessing Your Vehicle

### Smart key

Type A

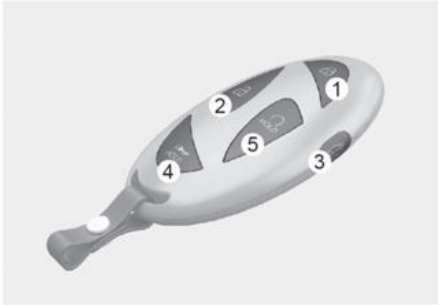

Type B



Your electric vehicle uses a smart key that can be used to lock or unlock the doors, trunk, and start the vehicle.

- (1) Door lock
- (2) Door unlock
- (3) Trunk open
- (4) Panic
- (5) Remote Start
- (6) Forward / Backward (if equipped)

### Locking your vehicle

Manual type



To lock your vehicle using the door handle button or the smart key:

1. Close all doors, hood, and trunk.
2. Press the Door Lock button (1) on the smart key. The hazard warning lights blink with an alarm, and the doors lock.
3. In addition, touching the outer part of the door handle on or near the handle detent while having the smart key with you locks all doors.

Electric type (if equipped)

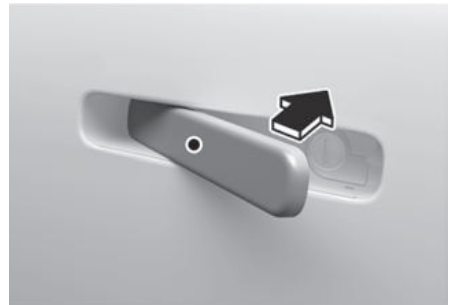

To lock your vehicle using the door handle touch sensor or the smart key:

1. Close all doors, hood, and trunk.
2. Press the Door Lock button (1) on the smart key. The hazard warning lights blink with an alarm, and the handles retract back.

- In addition, touching the outer part of the door handle on or near the handle detent for about 1 second while having smart key with you locks all doors and let the door handle to retract back.

### **i** Information

- The side view mirror will fold if '**Enable on Door Unlock**' is selected from the Settings menu in the infotainment system. Select **Setup > Vehicle > Lights > Welcome Mirror/Light > Enable on Door Unlock**.
- The door handle touch sensor operates when the smart key is within 28-40 in. (0.7-1 m) from the outside door handle.
- If you lock the doors using the door handle touch sensor, the doors are not locked under the following circumstances:
  - The smart key is in the vehicle.
  - The Start/Stop button is from ACC or ON position.
  - Any door is open (except for the trunk).
- If this occurs, a chime sounds for a few seconds. Check the vehicle before attempting to lock the vehicle again.

### **!** WARNING

Do not leave the smart key in your vehicle with children that are unattended or unsupervised.

Children could unintentionally press the Start/Stop button or could operate the power windows or other vehicle controls or even cause the vehicle to move. This may result in serious injury or death.

### **i** Information

- To fold/unfold the side view mirror simultaneously when the door is locked/unlocked, select **Setup > Vehicle > Lights > Welcome Mirror/Light > Enable on Door Unlock** in the infotainment system.
- The door handle button will only operate when the smart key is within 28-40 in. (0.7-1 m) from the outside door handle. Other people can also open the doors without the smart key in possession.
- After unlocking the doors, the doors will lock automatically after 30 seconds unless a door is opened.

The infotainment system may change after software updates. For more information, refer to the user's manual provided in the infotainment system and the quick reference guide.

### **Unlocking your vehicle**

Manual type



To unlock your vehicle using the door handle button or the smart key:

1. Have the smart key with you.
2. Pushing the button on the door handle(engraved part) or press the Door Unlock button (2) on the smart key. All doors handles will be unlocked and the hazard warning lights will blink twice.

- After unlocking the doors, the doors will automatically re-lock after 30 seconds unless a door is opened.

Electric type (if equipped)



### When you release the Two Press Unlock function

To unlock your vehicle using the door handle touch sensor or the smart key:

- Have the smart key with you.
- Touch the touch sensor on the door handle (engraved part) or press the Door Unlock button (2) on the smart key. All door handles will pop out and the doors will be unlocked and the hazard warning lights will blink and the chime will sound.
  - If you unlock the doors using the passenger side door handle, all the doors are unlocked. If you unlock the doors using the driver side door handle, either the driver's side door is unlocked or all the doors are unlocked depending on the setting for the Two Press Unlock feature. Change the Driver Door unlock mode by referring to "Setting the Two Press Unlock feature".

### *i* Information

- The side view mirror will unfold if 'Enable on Door Unlock' is selected from the Settings menu in the infotainment system. Select **Setup > Vehicle > Lights > Welcome Mirror/Light > Enable on Door Unlock**.

- The door handle button or touch sensor only operates when the smart key is within 28-40 in. (0.7-1 m) from the outside door handle.
- If you do not open the door after unlocking within 30 seconds, it returns to the lock mode.

### Setting the Two Press Unlock feature

You can activate or deactivate the Two Press Unlock feature from the Settings menu in the infotainment system.

Select **Setup > Vehicle > Door > Two Press Unlock**.

### *i* Information

The infotainment system may change after software updates. For more information, refer to the user's manual provided in the infotainment system and the quick reference guide.

### Setting the door lock/unlock prevention feature

The doors may lock or unlock if the touch sensor of the outside door handle is recognized while washing your vehicle or due to heavy rain.

### To prevent unintentional door lock or unlock:

Press the lock button on the smart key and immediately press the unlock button along with the lock button for more than 4 seconds. The hazard warning lights blink four times. At this time, the doors do not lock or unlock even though the touch sensor is touched on the outside door handle. To deactivate the function, press the door lock or unlock button on the smart key.

### **i** Information

During a vehicle wash or rain, in order to minimize unintentional operation of the touch sensor, the touch sensor may become insensitive. This is not a malfunction.

---

### **Opening the trunk**

To open the trunk:

1. Have the smart key with you.
2. Press the trunk handle switch on the vehicle or press and hold smart key button(3) on the smart key for more than one second. The hazard warning lights blink twice and the trunk is opened. If you release the button while the trunk is being closed, it will stop working and the chime will sound for about 5 seconds.

### **i** Information

The trunk open button only operates when the smart key is within 28 in. (0.7 m) from the trunk.

---

### **Remotely starting vehicle**

1. Press the door lock button on the smart key. You must be within about 32 ft. (10 m) from the vehicle.
2. Press and hold the Remote Start button (5) on your smart key. You must press the button within 4 seconds from when you have pressed the door lock button. The hazard warning lights blink and the vehicle starts (READY indicator on).
3. To turn off the vehicle, press the Remote Start button (5) once.

### **i** Information

- The vehicle must be in P (Park) for the remote start function to start.
- The vehicle turns off (READY indicator off) if you get inside the vehicle without a registered smart key.

- The vehicle turns off if you do not get on the vehicle within 10 minutes after remotely starting the vehicle.
  - The Remote Start button may not operate if the smart key is not within 32 ft. (10 m) from the vehicle.
  - The vehicle does not remotely start if the hood or trunk is open.
- 

### **Remotely moving vehicle forward or backward**

 If equipped

Some models are equipped with the Remote Smart Parking Assist feature.

With the smart key, the vehicle can be moved forward or backward remotely to enter or exit a tight parking space.

For more information, refer to the “Remote Smart Parking Assist 2 (RSPA 2)” section in chapter 7.

### **Using panic alarm**

The horn sounds and the hazard warning lights blink for about 30 seconds if this button (4) is pressed for more than 1 second. To stop the horn and lights, press any button on the smart key.

### **Starting the vehicle**

Your vehicle is equipped with a Start/Stop button instead of a key cylinder. You can leave your smart key in your pocket or purse when you start your vehicle.

For more information, refer to the “Start/Stop Button” section in chapter 6.

### **i** Information

If the smart key is not moved for some time, the detection function for smart key operation will pause. Lift the smart key to activate the detection again.

---



**NOTICE**

To prevent damaging the smart key:

- Keep the smart key in a cool, dry place to avoid damage or malfunction. Exposure to moisture or high temperature may cause the internal circuit of the smart key to malfunction which may not be covered under warranty.
- Avoid dropping or throwing the smart key.
- Protect the smart key from extreme temperatures.

**Loss of a smart key**

A maximum of three smart keys can be registered to a single vehicle. If you happen to lose your smart key, it is recommended that you should immediately take the vehicle and remaining keys to your authorized HYUNDAI dealer or tow the vehicle, if necessary.

**Smart key precautions**

The smart key may not work if any of the following occur:

- The smart key is close to a radio transmitter such as a radio station or an airport which can interfere with normal operation of the transmitter.
- The smart key is near a mobile two way radio system or a mobile phone.
- Another vehicle's smart key is being operated close to your vehicle.
- The smart key is near any normal electronic devices or credit cards.

If the smart key does not work correctly, open and close the door with the mechanical key. If you have a problem with the smart key, contact an authorized HYUNDAI dealer.

If the smart key is in close proximity to your mobile phone, the signal could be blocked by your mobile phone's normal operational signals. This is specifically relevant when the phone is active such as making and receiving calls, text messaging, and/or sending/receiving emails. When possible, avoid keeping the smart key and your mobile phone in the same location such as pants or jacket pocket in order to avoid interference between the two devices.

If your windows are tinted, especially with metallic window tint, it may cause frequency interference, reducing the smart key operating range.

**i Information**

Changes or modifications not expressly approved by the party responsible for compliance could void the user's authority to operate the equipment. If the keyless entry system is inoperative due to changes or modifications not expressly approved by the party responsible for compliance, it will not be covered by your manufacturer's vehicle warranty.

**i Information**

This device complies with Part 15 of the FCC rules.

Operation is subject to the following three conditions:

1. This device may not cause harmful interference, and
2. This device must accept any interference received, including interference that may cause undesired operation.
3. Changes or modifications not expressly approved by the party responsible for compliance could void the user's authority to operate the device.

### NOTICE

- Keep the smart key away from electromagnetic materials that blocks electromagnetic waves to the key surface.
- Always have the smart key with you when leaving the vehicle. If the smart key is left near the vehicle, the vehicle battery may be discharged.

### Battery replacement

If the smart key is not working properly, try replacing the battery with a new one.

Battery Type: CR2450

To replace the battery:

1. Put the slim tool into the key hole (1) to pry open the rear cover of the smart key.



2. Remove the old battery and insert the new battery. Make sure the battery position is correct. An improperly positioned battery may discharge the battery, causing smart key failure.

3. Reinstall the battery cover and smart key cover.

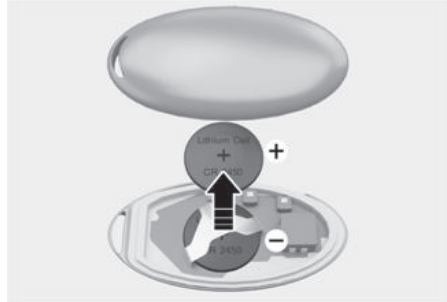

If you suspect your smart key might have sustained some damage, or you feel your smart key is not working correctly, contact an authorized HYUNDAI dealer.

### ⚠ WARNING

This product contains a button battery.

If swallowed, a lithium button battery can cause severe or fatal injuries within 2 hours. Keep batteries out of reach of children.

If you think batteries may have been swallowed or placed inside any part of the body, seek immediate medical attention.

### *i* Information



An inappropriately disposed battery can be harmful to the environment and human health. Dispose of the battery according to your local law(s) or regulations.

## Immobilizer System

The immobilizer system helps protect your vehicle from theft. If an improperly coded key (or other device) is used, the vehicle is disabled.

When the Start/Stop button is pressed to the ON position, the immobilizer system indicator should come on briefly, then go off. If the indicator starts to blink, the system does not recognize the coding of the key.

Press the Start/Stop button to the OFF position, then press the Start/Stop button to the ON position again.

In some circumstances, the vehicle may not recognize your smart key if another smart key device is nearby or a metal object such as a key chain is causing interference with the smart key.

If this occurs, your vehicle may not start. Remove any metal objects or additional keys near the smart key before attempting to start the vehicle again.

If the system repeatedly does not recognize the coding of the key, contact an authorized HYUNDAI dealer.

Do not attempt to alter this system or add other devices to it. Electrical problems could result that may make your vehicle inoperable.

### WARNING

In order to prevent theft of your vehicle, do not leave spare keys anywhere in your vehicle. Your immobilizer password is a customer unique password and should be kept confidential.

### NOTICE

The transponder in your key is an important part of the immobilizer system. It is designed to give years of trouble-free service, however you should avoid exposure to moisture, static electricity and rough handling. Immobilizer system malfunction could occur.

### *i* Information

This device complies with Part 15 of the FCC rules.

Operation is subject to the following three conditions:

1. This device may not cause harmful interference.
2. This device must accept any interference received, including interference that may cause undesired operation.
3. Changes or modifications not expressly approved by the party responsible for compliance could void the user's authority to operate the device

## Hyundai Digital Key

 If equipped

Hyundai digital key provides convenience to the driver, which the driver can use to lock or unlock the driver and passenger doors or the trunk and turn on the vehicle.

### Digital key (smartphone)

#### *i* Information

- Hyundai digital keys are only available on smartphone that support digital key functions, and digital key functions of smartphones are provide by smartphone manufacturers.
- Available smartphone models can be found on smartphone manufactures' website or HYUNDAI website.
- Depending on the availability of service on the vehicle, some functions may not operated.

#### **Setting your smartphone**

To use the digital key (smartphone), download the BlueLink App and sign up Hyundai account and service.

For more information about BlueLink, refer to the infotainment system guide.

#### **Registering your digital key (smartphone)**

- Turn on the vehicle with a smart key and have your smart key with you in the vehicle.
- After selecting **Digital Key > Set Up Digital Key** from the My Hyundai App in the smartphone, register the digital key according to the guidance in the smartphone screen.
  - Place your smartphone on the vehicle authentication pad (wireless charging pad) with the screen facing up. (In case of Apple WATCH, the watch face must be on the pad).



[A] Vehicle authentication pad (Wireless charging pad)

- When the digital key (smartphone) is saved, a message appears on the infotainment system.

#### *i* Information

- The NFC Antenna position on Samsung device can be found in the following path: **Setup > Connections > NFC and contactless payments**.
- The NFC Antenna position on Google Pixel phone can be found in the following path: **Settings > Connected devices > Connection preference > NFC**.
- The NFC Antenna position on Apple iPhone is located at the top of the rear (A) and Apple WATCH is located at the center of the screen (B).



- Ensure that the NFC Antenna position on the smartphone is in contact with the vehicle authentication pad (wireless charging pad).

- The location of the NFC Antenna on the smartphone may vary by phone model, so please contact the smartphone manufacturer for details.
  - NFC communication may not work for some smartphones depending on the internal structure of the smartphone. Move the smartphone to the left or right of the indoor authentication pad (wireless charging pad) to operate.
4. Place your smartphone on the vehicle authentication pad (wireless charging pad) with the screen facing up. (In case of Apple WATCH, the watch face must be on the pad).
    - When the digital key (smartphone) is saved, a message appears on the infotainment system.

### *i* Information

- The infotainment system may change after software updates. For more information, refer to the user's manual provided in the infotainment system and the quick reference guide.
- If you want to register a different digital key (smartphone), refer to "Deleting your digital key (smartphone)" and delete the digital key (smartphone) before re-registering. An active Digital Key can be shared through the Bluelink App with a different smartphone.
- During the digital key saving process, the process may cancel when:
  - The smartphone is removed from the vehicle authentication pad (wireless charging pad)
  - The infotainment system is changed
  - The vehicle is turned off
  - The gear is shifted
- The registering process does not start if a smart key is not in the vehicle.
- Some smartphones may not start the registering process depending on the internal structure. Move the smartphone to the left or right on the vehicle authentication pad (wireless charger pad) and try registering the smartphone.

### To register the digital key (smartphone) from the infotainment system



If you cannot register the digital key (smartphone) with the Bluelink App, try registering from the infotainment system.

1. Turn off the vehicle, and then turn on the vehicle with a smart key and have your smart key with you in the vehicle.
2. After selecting **Digital Key > Set Up Digital Key** from the My Hyundai App in the smartphone, register the digital key according to the guidance in the smartphone screen.
3. Put the gear in P (Park), press the **SETUP** button, and then select **Vehicle > Digital key > Smartphone key > My Smartphone Key > Save** button from the Settings menu in the infotainment system.

### Using the digital key (smartphone)

The driver can lock or unlock the door by placing the smartphone on the outside door handle, and the vehicle can be started by placing the smartphone on the vehicle authentication pad (wireless charging pad).

Samsung smartphone

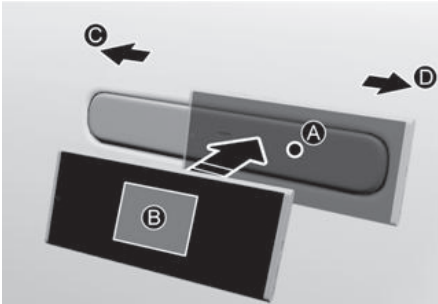

[A] Door handle authentication pad  
[B] NFC Antenna

Apple iPhone

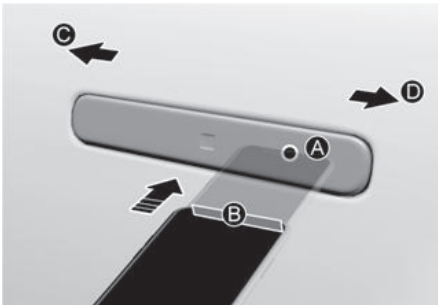

[A] Door handle authentication pad  
[B] NFC Antenna

### **i** Information

- The location of the NFC Antenna on the smartphone may vary by phone model, so please contact the smartphone manufacturer for details.
- The NFC Antenna position on Samsung device can be found in the following path: **Setup > Connections > NFC and contactless payments**.

- The NFC Antenna position on Google Pixel phone can be found in the following path: **Settings > Connected devices > Connection preference > NFC**.
- The NFC Antenna position on Apple iPhone is located at the top of the rear (A) and Apple WATCH is located at the center of the screen (B).



- Touch the door handle NFC Antenna position with the back of your smartphone. (In case of Apple WATCH, need to touch the pad with WATCH screen face).

### Locking/Unlocking the doors

- If the driver places the digital key (smartphone) NFC antenna to the driver's or passenger's door handle authentication pad (A) for more than 2 seconds, the door locks or unlocks.
- After unlocking the doors, the doors are automatically re-lock after 30 seconds unless a door is opened.
- If the smartphone digital key does not operate, try again after moving the smartphone away from the door handle authentication pad (more than 0.1 m (4 in.)).

## *i* Information

You cannot lock your vehicle using the digital key (smartphone) if any of the following occurs:

- The smart key is in the vehicle.
- The Start/Stop button is in the ACC or ON position.
- Any of the doors, hood, or trunk are open.

### Starting the vehicle

After placing your registered digital key (smartphone) on the vehicle authentication pad (wireless charging pad), depress the brake pedal and press the Start/Stop button.

After starting the vehicle, the digital key (smartphone) may be removed from the vehicle authentication pad (wireless charging pad).

For more details on the basic way to start the vehicle, refer to the "Start/Stop Button" section in chapter 6.

## *i* Information

If a shared digital key (smartphone) is used for the first time, the activating time may take longer.

- Place the shared digital key (smartphone) on the door handle authentication pad until the vehicle door lock/unlock activates.
- If a shared digital key (smartphone) is first used on the vehicle authentication pad (wireless charger pad), the initial start of the vehicle may fail.
- If the door lock/unlock is activated once with the shared digital key (smartphone) or the vehicle is started with the digital key (smartphone) on the vehicle authentication pad, the digital key (smartphone) is registered in the vehicle.

## WARNING

The vehicle can be started when the registered smartphone is placed on the vehicle authentication pad (wireless charging pad). Therefore, do not leave unsupervised children or people who are not aware of the system since it can result in serious injury or death. In addition, always have the registered smartphone with you to prevent vehicle theft when leaving the vehicle.

### ***Deleting your digital key (smartphone)***

Turn on the vehicle with a smart key. Have your smart key with you in the vehicle.

### **Deleting all registered digital key (smartphone)**

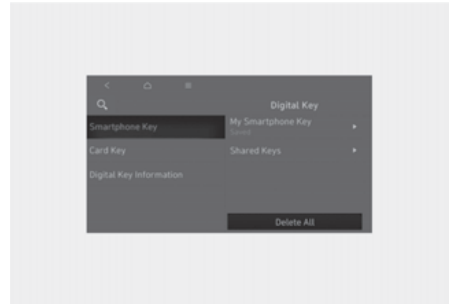

To delete all the registered digital key (smartphone), from the Settings menu select **Setup > Vehicle > Digital key > Smartphone Key > Delete all** in the infotainment system.

- The "**Delete all**" button is disabled if there is no registered digital key (smartphone).

### Deleting my registered digital key (smartphone)

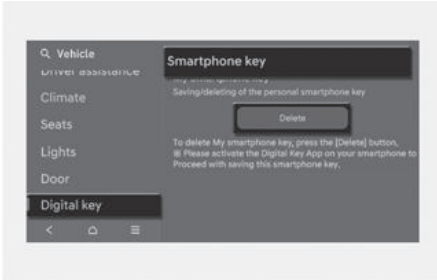

To delete only my registered digital key (smartphone), from the Settings menu select **Setup > Vehicle > Digital key > Smartphone Key > My Smartphone Key > Delete** in the infotainment system.

- If a shared digital key (smartphone) is registered, it cannot be deleted.
- A new smartphone can be registered after deleting the existing digital key (smartphone) from "**My Smartphone Key**" menu.

### **i** Information

- If the registered digital key (smartphone) is deleted, the digital key saved in the smartphone is also deleted.
- If the digital key is deleted from the smartphone, the digital key (smartphone) registered in the vehicle is also deleted.
- The shared digital key registered in the vehicle cannot be deleted individually.
- Even though the BlueLink® App is deleted from the smartphone, the digital key saved in the smartphone is not deleted.
- Management of the digital key saved in the smartphone is available from the Digital Key App provided by the smartphone manufacturer.

## Digital key (Card key)

### **How to register Digital key (Card Key)**

To use the card key as a digital key, follow the following procedure.

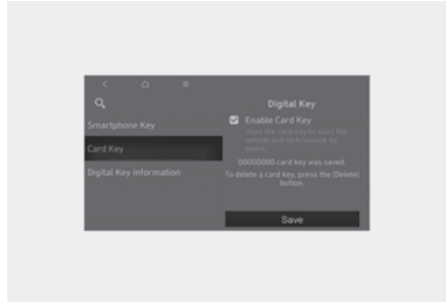

[A] Vehicle authentication pad (Wireless charging pad)

1. Have both of your smart keys with you in the vehicle.
2. Select **Setup > Vehicle > Digital Key > Card Key** from the Settings menu, and check whether "**Enabled card key**" is selected in the infotainment system.
3. Place your card key on the vehicle authentication pad (wireless charging pad) while the vehicle is on.
4. Register your card key by selecting **Setup > Vehicle > Digital Key > Card Key > Save** from the Settings menu in the infotainment system.



## *i* Information

- When there is a digital key (card key) already registered in the vehicle, a new digital key (card key) cannot be registered. Re-register a new digital key (card key) after deleting the exiting digital key (card key).
- To register a digital key (card key), both of your smart keys must be in the vehicle.
- A registered digital key (card key) cannot be registered in other vehicles.

### **Using the digital key (card key)**

The driver can lock or unlock the door by placing the card key on the outside door handle, and the vehicle can be started by placing the card key on the vehicle authentication pad (wireless charging pad).

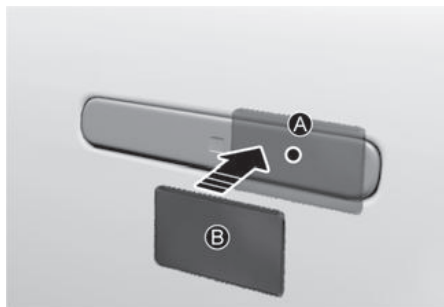

[A] Door handle authentication pad  
[B] Card key NFC Antenna

### **Locking/Unlocking the doors**

- If the driver places the digital key (card key) to the driver's or passenger's door handle authentication pad (A) for more than 2 seconds, the door locks or unlocks.
- After unlocking the doors, the doors are automatically re-lock after 30 seconds unless a door is opened.

## *i* Information

You cannot lock your vehicle using the digital key (card key) if any of the following occurs:

- The smart key is in the vehicle.
- The Start/Stop button is in the ACC or ON position.
- Any of the doors, hood, or trunk are open.

### **Starting the vehicle**

After placing your registered digital key (card key) on the vehicle authentication pad (wireless charging pad), depress the brake pedal and press the Start/Stop button.

For more details on the basic way to start the vehicle, refer to "Start/Stop Button" section in chapter 6.

## **! WARNING**

The vehicle can be started when the registered card key is placed on the vehicle authentication pad (wireless charging pad). Therefore, do not leave unsupervised children or people who are not aware of the system since it can result in serious injury or death. In addition, always have the registered card key with you to prevent vehicle theft when leaving the vehicle.

## **NOTICE**

- The digital key (card key) may not work under the following conditions:
  - The digital key (card key) is not placed on the door handle authentication pad or vehicle authentication pad (wireless charging pad) correctly.

- The digital key (card key) is near NFC-enabled cards such as credit cards or smartphones.

If the digital key (card key) does not work, try again after moving the digital key (card key) away from the door handle authentication pad (more than 0.1 m (4 in.)).

- The digital key (card key) can be damaged by impacts. If the digital key (card key) is damaged, replace the digital key (card key) with a new one and register it again.
- Long-time exposure to high temperature may cause the digital key (card key) to malfunction. Be careful not to expose the digital key (card key) to direct sunlight or high temperature.
- Leaving the digital key (card key) on the in-vehicle authentication pad (wireless charging pad) while driving may cause the digital key (card key) to malfunction. Remove the digital key (card key) from the in-vehicle authentication pad (wireless charging pad) after starting the vehicle.
- Remove the digital key (card key) from the smartphone before charging the smartphone. If the digital key (card key) is placed between the smartphone and the in-vehicle authentication pad (wireless charging pad) while the smartphone is being charged, the digital key (card key) may malfunction. For example, when charging smartphone while the digital key (card key) is attached to the back of the smartphone case.

### Deleting your digital key (card key)



1. Turn on the vehicle with a smart key. Have your smart key with you in the vehicle.
2. From the infotainment system Settings menu, select **Setup > Vehicle > Digital Key > Card Key > Delete**.
  - The "Delete" button is disabled if there is no digital key (card key) registered.

### Personalized profile and vehicle settings

You can set the registered digital key (smartphone) profiles for Driver 1 and Driver 2. When you use the digital key (smartphone), the vehicle can be set to the user-defined personalized profile (includes items such as vehicle settings and audio preferences).

### Linking/Unlinking profile

#### How to link user profile

1. Select **Setup > User Profile > Profile Settings > Link Digital Key (Smartphone)** from the Settings menu in the infotainment system.
2. Select "Link" to connect the registered smartphone's digital key and the user's profile.
3. Follow the instructions according to the message on the infotainment system screen.

### How to unlink user profile

Select **Setup > User Profile > Profile Settings**, and then deselect "**Link Digital Key (Smartphone)**" from Settings menu in the infotainment system.

- Unlinking is possible only when user profile is linked.

### *i* Information

- User profile cannot be linked to both Driver 1 and Driver 2 that are connected to single smartphone. Personalization operates with the recently linked user profile, and the previously linked user profile will be automatically canceled.
- User profile link works only when the digital key is registered to the vehicle.
- Digital key (card key) cannot be linked with a user profile.
- If the user profile linked digital key in the smartphone is deleted, the digital key should be re-registered and personalized by linking the user profile again.

### **Vehicle personalization operation**

- The personalization function linked with digital key works when the profile linked smartphone is placed on the outside door handle authentication pad to lock or unlock the doors.
- The profile set by the digital key can be changed manually from the infotainment system.
- The personalization function using the digital key can be operated after linking the digital key in the infotainment system profile menu.
- The personalization function works only when the vehicle is OFF or when the vehicle is started remotely. If the vehicle is not started remotely, the personalization function does not work with the digital key.

### *i* Information

User profile operation according to door lock/unlock system is as follows:

Item	Personalization Operation
Initial value	Guest
Profile linked smartphone key	Linked profile
Profile unlinked smartphone key	Recently activated profile
NFC card key	
Smart key	

### Used vehicle/Digital key maintenance

#### ***Purchasing used vehicle***

If any of the digital key devices (smartphone key, card key) are registered in the vehicle, the "**Digital key registered**" message appears once on the infotainment system screen or instrument cluster when the Start/Stop button is in the ON position after unlocking the doors. When purchasing a used vehicle, make sure to check the message and delete the smartphone key and card key registered by the previous user and inform the purchase of a used vehicle through Hyundai Customer Care Center.

If the card key comes with the vehicle, check whether it operates properly.

#### ***Digital Key maintenance***

If you need to repaired or replaced your Digital Key system, make sure your smartphone key is still active. You may have to pair your phone again using the HYUNDAI Digital Key app.

#### **Limitations of the System**

HYUNDAI Digital Key app on the smartphone and card key may not work if:

- HYUNDAI Digital Key app is deleted.
- Account login information for HYUNDAI Digital Key app has expired.
- Logged in with another smartphone instead of the registered smartphone with the same user account.

- Smartphone rooting or app hacking is detected.
- Smartphone battery or the vehicle battery is discharged.
- Smartphone screen is off or locked.
- NFC or Bluetooth is turned off on the smartphone Setup.
- Smartphone's mobile network setting is off or airplane mode is activated.
- The card key is in a wallet or card holder, or overlapped with other cards.
- If you use a smartphone cover that uses wireless communication or is made of metal, remove the smartphone cover.

The vehicle may not be controlled by the smartphone if any of the following occurs:

- Other smartphone functions (calls, urgent call, audio or NFC payment), apps, or wireless earphones are operating.
- The digital key app function such as basic setting or app launching is limited by the prior policy according to the manufacturer.
- If you have changed the smartphone number, modify the user account information on the HYUNDAI customer web site.
- If the vehicle owner has changed the smartphone, register the new smartphone in the vehicle after deleting the registered digital key (smartphone).
- If a sharer have changed or reset the smartphone, share the key again.

## Door Locks

### Operating Door Unlocks from Outside the Vehicle (Manual type)

#### Smart key

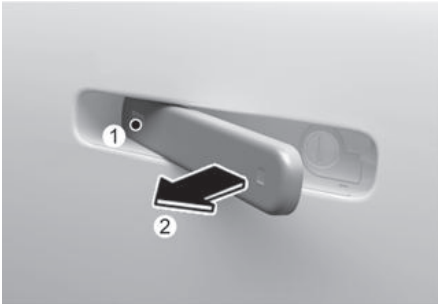

Push the button on the front outside door handle (the engraved part) while carrying the smart key with you, all doors will unlock.

The hazard warning lights will blink twice and chime also sounds twice.

Once the doors are unlocked, when press the front of the door handle (1) then rear of the door handle will pop out (2).

Pull the outside door handle to open the door.

### Operating Door Unlocks from Outside the Vehicle (Electric type)

if equipped

#### Smart key

##### Approach unlock system

The outside door handle will slide out and the doors will unlock when the driver approaches the vehicle possessing the smart key.

The driver can activate/deactivate the “Approach unlock” system on the infotainment system.

To activate Approach unlock system for only the driver's seat, select **Settings > Vehicle > Door > Unlock all doors** in the infotainment system.

To activate Approach unlock system, select **Settings > Vehicle > Door > Activate approach unlock** in the infotainment system. The outside door handle will slide out and the door will unlock when the driver approaches the vehicle possessing the smart key. If Approaching unlock system is deactivated, the door handle will not slide out even when the driver approaches to the vehicle with the smart key. To unlock doors when Approach unlock system is deactivated, touch the lock/unlock sensor (engraved part) on the handle.

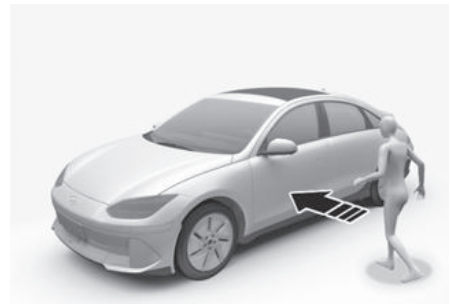

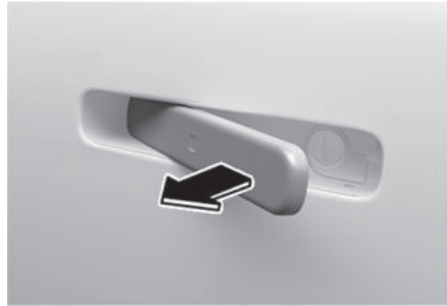
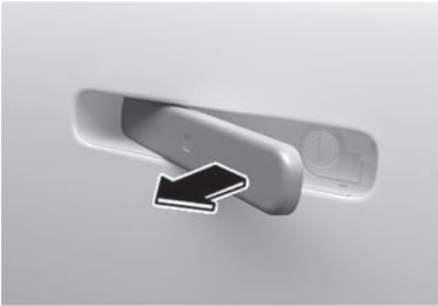

- When the 'Approach unlock' is activated:
  - If you approach (within 40 in. (1 m)) the driver or front passenger's door handle possessing the smart key, the outside door handles slide out and the doors are unlocked. In this case, Hazard Warning Flasher blinks twice and chime also sounds twice.
  - After first approach, the vehicle tries detecting the smart key every 5 seconds and if the key is not detected, the doors will lock automatically and the handles will slide in.

- When the 'Approach unlock' is deactivated: The handle does not slide out even when you approach with the smart key in possession. The doors are unlocked if you press the outside handle as the handles slide out.
- The doors will lock automatically and the handles will slide in after 30 seconds unless a door is opened.

### *i* Information

In emergency situations, such as battery is dead, the outside electric door handle can still be operated in a way that the outside manual door handle operate.

---



## Operating Door Locks from Outside the Vehicle (Manual type)

### Smart key



Push the button on the front outside door handle (the engraved part) while carrying the smart key with you, all doors will lock. The hazard warning lights will blink and chime also sounds once. Push the door to close.

## Operating Door Locks from Outside the Vehicle (Electric type)

 if equipped

### Smart key

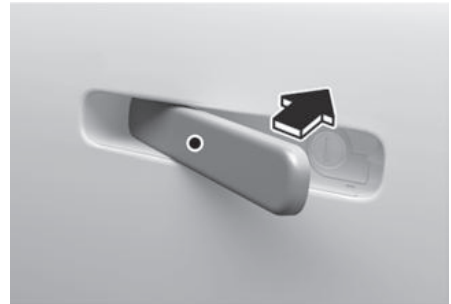

When all doors are closed, touch the touch sensor on the front outside door handle (the engraved part) while carrying the smart key with you, outside door handle will return and doors will be locked.

The hazard warning lights will blink and chime also sounds once.

### NOTICE

- If the door is locked/unlocked multiple times in rapid succession with the smart key, door lock button or door lock switch, the system may stop operating temporarily in order to protect the circuit. Also, the “Approach unlock” system may not operate. Try operation after a sufficient time in case the system does not operate due to multiple operations.
- “Approach unlock” system is not operated continuously. Retry after a certain period of time when all the doors are closed.

## **i** Information

- In cold and wet climates, door lock and door mechanisms may not work properly due to freezing conditions.
- If the door is locked/unlocked multiple times in rapid succession with either the vehicle key or door lock switch, the system may stop operating temporarily in order to protect the circuit and prevent damage to system components.
- When washing the vehicle
  - Self vehicle wash  
Keep the door locked with the outside door handle closed.  
To keep the door unlocked, push back the outside door handle by hand. This function prevents the door handle from being damaged, and the door handle pops out again when the unlock button is pressed.
  - Auto vehicle wash  
Keep the door locked with the outside door handle closed.  
If the smart key is not in the vehicle, turn off the vehicle and stay the smart key away at least 78 in. (2 m) from the vehicle to prevent the outside door handle operates.

## **Digital key**

 If equipped

For more information, refer to the "Hyundai Digital Key" section in this chapter to lock or unlock the door from outside vehicle with digital key.

Pull the outside door handle to open the door after unlocking the door. Push the door to close.

## **Mechanical key**

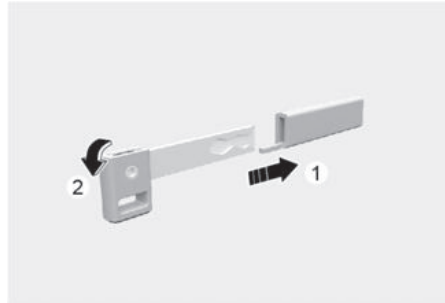

Turn the knob (2) of the mechanical key after removing the key protector (1).

Press the front part (3) of the door handle to pull out the rear part of the door handle. While keep pressing the front part of the door handle, insert the mechanical key (4) to the lock.

To lock the door, turn the key toward the front (left side) of the vehicle. To unlock, turn the key toward the rear (right side) of the vehicle.

## **NOTICE**

Do not apply excessive force on the door and door handle. It may damage the door and door handle.

The mechanical key only locks/unlocks the driver's door handle. For more information, refer to the "In case of an emergency" section in this chapter.



### *i* Information

When the door handle or the keyhole freeze and do not open, lightly tap or indirectly warm (for example, hand temperature) the keyhole.

Since the smart key and the mechanical key are separated, always carry the mechanical key in case the vehicle battery and the smart key battery are discharged.

### ***In case of an emergency***

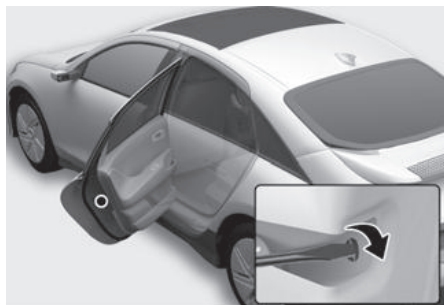

Doors without an outside key hole can be locked as follows:

1. Open the door.
2. Insert a small blade tool (for example, screwdriver or similar) into the emergency door lock hole and turn it clockwise for left side door, or turn it counterclockwise for right side door.
3. Close the door securely.

### *i* Information

If the electrical power to door lock switch is not operating (for example, discharged vehicle battery) and the trunk is closed, you cannot open the trunk until power is restored.

### **!** WARNING

- Always close and lock the doors while the vehicle is moving. If the doors are unlocked, the risk of being thrown from the vehicle in a collision increases.
- Do not pull the inner door handle of the driver's or passenger's door while the vehicle is moving.

### **!** WARNING

Do not leave the elderly, children, or animals unattended in your vehicle. An enclosed vehicle can become extremely hot and the elderly, unattended children or animals who cannot escape the vehicle may be seriously injured or killed.

### **!** WARNING

Always park your vehicle properly. Depress the brake pedal, change the gear to P (Park), apply the parking brake, press the Start/Stop button to the OFF position, close all windows, lock all doors, and always take the keys with you.

### **!** WARNING

Be careful when opening doors and watch for vehicles, motorcycles, bicycles, or pedestrians approaching the vehicle to prevent serious injury or death.

### *i* Information

To exit the vehicle if the power door lock does not function:

- Operate the door unlock feature repeatedly (both electronic and manual) while simultaneously pulling on the door handle.

- Operate the other door locks and handles.
  - Lower the driver's front window and use the mechanical key to unlock the door from outside.
- 

### Operating Door Lock/Unlock from Inside the Vehicle

#### ***With the inside door handle***

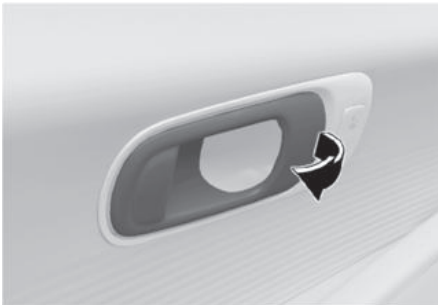

#### **Front door**



If the inner door handle is pulled when the door is locked, the door is unlocked and opened.

#### **Rear door - Two pull operation**

If the inner door handle is pulled once when the door is locked, the door is unlocked. If the inner door handle is pulled once more, the door is opened.

#### ***With the central door lock switch***



The central door lock switch is located on the center console. The lock switch is indicated by a  symbol. The unlock switch is indicated by a  symbol.

When the lock switch (1) is pressed, all the vehicle doors will lock.

When the unlock switch (2) is pressed (door indicator light ON), all the vehicle doors will unlock.

If any door is opened, the doors will not lock even though the central door lock button (1) is pressed.

#### ***NOTICE***

If the smart key is in the vehicle and the front door is opened, the central door lock button (1) cannot lock the doors.

---

### Automatic Door Lock and Unlock Features

Your vehicle is equipped with features that will automatically lock or unlock your vehicle based on settings you select in the infotainment system.

#### ***Auto Lock Enable on speed***

When this feature is set in the infotainment system, all the doors will be locked automatically when the vehicle exceeds 9 mph (15 km/h).

**Auto Lock Enable on shift**

When this feature is set in the infotainment system, all the doors will be locked automatically when the vehicle is shifted out of P (Park) while the vehicle is running.

**Auto Unlock Enable on shift to P**

When this feature is set in the infotainment system, all the doors will be unlocked automatically when the vehicle is shifted back into P (Park) while the vehicle is running.

**Auto Unlock Enable at Vehicle Off**

When this feature is set in the infotainment system, all the doors will be unlocked automatically when the vehicle is turned off.

***i* Information**

The infotainment system may change after software updates. For more information, refer to the user's manual provided in the infotainment system and the quick reference guide.

**Additional unlock safety feature  
airbag deployment**

As an additional safety feature, all doors will be automatically unlocked when an impact causes the airbags to deploy.

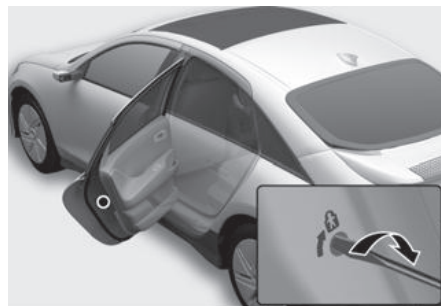
**Child-Protector Rear Door Locks**

The child safety lock is provided to help prevent children seated in the rear from accidentally opening the rear doors. The rear door safety locks should be used whenever children are in the vehicle.

The child safety lock is located on the edge of each rear door. When the child safety lock is in the lock position, the rear door will not open if the inner door handle is pulled.

To lock the child safety lock, insert a small flat blade tool (for example, screwdriver or similar) into the slot and turn it to the lock position as shown.

To allow a rear door to be opened from inside the vehicle, unlock the child safety lock.

**⚠ WARNING**

Never allow children to open the rear doors while the vehicle is moving. They may fall out of the vehicle. Be sure to use the rear door safety locks whenever children are in the vehicle.

## Theft-Alarm System

This system helps to protect your vehicle and valuables. The horn will sound and the hazard warning lights will blink continuously if any of the following occur:

- A door is opened without using the smart key.
- The trunk is opened without using the smart key.
- The vehicle hood is opened.

The alarm continues for 30 seconds, then the system resets. To turn off the alarm, unlock the doors with the smart key.

The Theft Alarm System automatically sets 30 seconds after you lock the doors and the trunk. For the system to activate, you must lock the doors and the trunk from outside the vehicle with the smart key or by touching the touch sensor or pressing the button on the outside door handle with the smart key in your possession.

The hazard warning lights will blink and the chime will sound once to indicate the system is armed.

Once the security system is set, opening any door, the trunk, or the hood without using the smart key will cause the alarm to activate.

The Theft Alarm System will not set if the hood, the trunk, or any door is not fully closed. If the system will not set, check the hood, the trunk, or the doors are fully closed.

Do not attempt to alter this system or add other devices to it.

### *i* Information

- Do not lock the doors until all passengers have left the vehicle. If the remaining passenger leaves the vehicle when the system is armed, the alarm will be activated.
  - If the vehicle is not disarmed with the smart key, open the doors by using the mechanical key and start the vehicle by directly pressing the Start/Stop button with the smart key.
  - If the system is disarmed by unlocking the vehicle, but neither a door or the trunk is opened within 30 seconds, the doors will relock and the system will rearm automatically.
-

## Rear Occupant Alert (ROA)

 if equipped

Rear Occupant Alert is provided to prevent a driver from leaving a vehicle with the rear passenger left in the vehicle.

### System Setting

To use Rear Occupant Alert, it can be enabled from the Settings menu in the infotainment system.

Select **Setup > Vehicle > Convenience > Rear Occupant Alert**.

#### Information

The infotainment system may change after software updates. For more information, refer to the user's manual provided in the infotainment system and the quick reference guide.

### System Operation

- First alert  
When you turn off the vehicle and open the driver's door after opening and closing the rear door or trunk, the **"Check rear seats for passengers and belongings"** warning message appears on the instrument cluster.
- Second alert (if the sensor equipped)  
After the first alert, the second alert operates when any movement is detected in the vehicle after the driver's door is closed and all the doors are locked. The horn sounds about 25 seconds. If the system continues to detect a movement, the alert operates up to 8 times.  
Unlock the doors with the smart key to stop the alert.
- The system detects movement in the vehicle for 10 minutes after the door is locked.

#### Information

- The second alert is activated only after the prior activation of the first alert.
- Rear Occupant Alert also activates when movement is detected in the cargo area.
- The second alert activates only when the sensor is equipped in the vehicle.

#### System precautions

- Make sure that all the windows are closed. If the window is open, the alert may occur when the sensor has detected any movement (for example, wind or bugs).

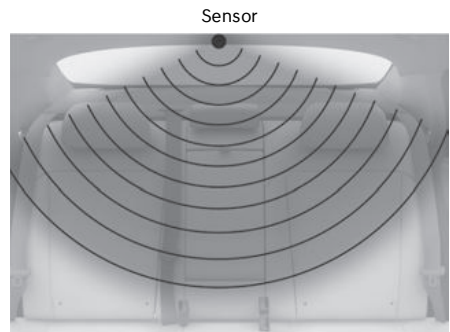

- If you do not want to use Rear Occupant Alert, press the **'OK'** switch on the steering wheel when the first alert appears and the second alert is deactivated once.

Instrument cluster

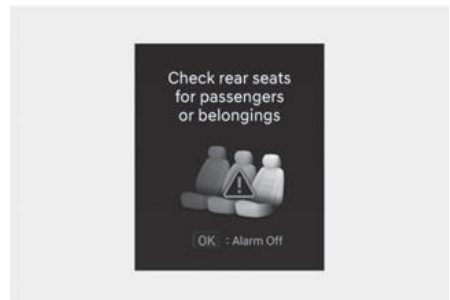

Steering wheel

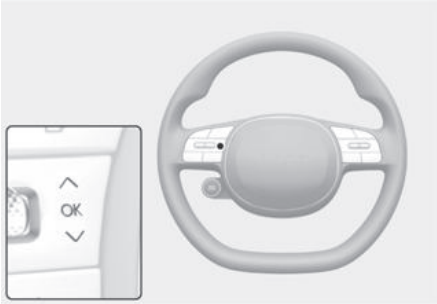

- If the vehicle is started remotely (if equipped with Remote Start), inside movement detection stops.
- The alert may occur if any movement is detected in the driver's or passenger's seat.
- If all doors are locked with a passenger in the vehicle, the alert may occur.
- The alert may occur if there is an impact on the vehicle.
- If boxes or objects are stacked in the vehicle, the system may not detect passengers. The alert may occur if the boxes or objects fall off or move.
- The alert may occur with the doors locked if the vehicle is pushed or shaken, or washed, or if there is sufficient external vibration or noise.
- The alert may occur when there are metallic or liquid objects in the vehicle.

### **WARNING**

Even if your vehicle is equipped with Rear Occupant Alert (ROA), always check the rear seat before you leave the vehicle.

Rear Occupant Alert (ROA) may not operate when:

- Movement does not continue for a certain period of time or the movement is small.
- The detection signal is weak because the signal is obscured by seat or CRS (for example, child is restrained in the forward-facing CRS).
- A child is not seated in a child restraint system.
- Movement is detected in areas other than the rear seats.
- The rear passenger is covered with a fabric made of metallic substance such as a blanket.
- The sensor is dirty or blocked with foreign substances.
- An animal at the rear seat is not large enough to be detected by the sensor or there is hardly any movement.
- Attaching objects or modifying the interior ceiling, or the interior ceiling is deformed or damaged.
- There are electronic interference around the vehicle.
- The external environment and other conditions are detected.

## Declaration of Conformity

The radio frequency components (ROA Radar Sensor) complies:

- For USA



FCC ID: NSZVITA001

This device complies with Part 15 of the FCC Rules. Operation is subject to the following two conditions:

- (1) this device may not cause harmful interference, and
- (2) this device must accept any interference received, including interference that may cause undesired operation.

### CAUTION TO USERS

Changes or modifications not expressly approved by the party responsible for compliance could void the user's authority to operate the equipment.

- For Canada

Model: VitaSense  
IC: 3019A-VITA001

This device complies with Industry Canada licence-exempt RSS standard(s). Operation is subject to the following two conditions:

- (1) this device may not cause interference, and
- (2) this device must accept any interference, including interference that may cause undesired operation of the device.

Le présent appareil est conforme aux CNR d'Industrie Canada applicables aux appareils radio exempts de licence. L'exploitation est autorisée aux deux conditions suivantes:

- (1) l'appareil ne doit pas produire de brouillage, et
- (2) l'utilisateur de l'appareil doit accepter tout brouillage radioélectrique subi, même si le brouillage est susceptible d'en compromettre le fonctionnement.

## Integrated Memory System

if equipped



Integrated Memory System for the driver's seat is provided to store and recall the following memory settings with a simple button operation.

- Driver's seat position
- Side view mirror position
- Head-up display position

### WARNING

Never attempt to operate the integrated memory system while the vehicle is moving.

### Information

- If the battery is disconnected, the memory settings will be erased.
- If integrated memory system does not operate normally, have the system inspected by an authorized HYUNDAI dealer.

## Storing Memory Positions

1. Shift to P (Park) while the Start/Stop button is in the ON position.
2. Adjust the driver's seat position, side view mirror position, and head-up display height to the desired position.
3. Hold the button (1 or 2). The system will beep once and notify you 'Driver 1 (or 2) settings saved' will appear on the infotainment system.

## Recalling Memory Positions

1. Shift to P (Park) while the Start/Stop button is in the ON position.
2. Press the desired memory button (1 or 2). The system will beep once, and then the driver's seat position, side view mirror position, and head-up display height will automatically adjust to the stored positions.
3. 'Driver 1 (or 2) settings applied' will appear on the infotainment system.

### **i** Information

- In order to adjust the memory button (2) while adjusting the memory button (1), press the memory button (1) to pause the adjustment of (1), then press memory button (2).
- If you adjust the seat, side view mirror, head-up display while recalling the stored positions, the manually adjusted settings will be applied.

## Resetting the System

Take the following procedures to reset integrated memory system, when it does not operate properly.

### **Resetting integrated memory system**

1. Stop the vehicle and open the driver's door with the Start/Stop button in the ON position and the vehicle shifted to P (Park).
2. Adjust the driver's seat and seatback to the foremost position.
3. Press the memory button 1 and push forward the driver's seat switch simultaneously (about two seconds).
4. Release the memory button and the driver's seat switch when a beep sounds.

### **While resetting integrated memory system**

1. Resetting starts with a notification sound.
2. The driver's seat and seatback is adjusted to the rearward position with the notification sound.
3. The driver's seat and seatback is re-adjusted to the default position (central position) with the notification sound.

However, in the following cases, the resetting procedure and the notification sound may stop.

- The memory button is pressed.
- The seat control switch is operated.
- The gear is shifted out of P (Park).
- The driving speed exceeds 2 mph (3 km/h).
- The driver's door is closed.



**NOTICE**

- While integrated memory system is being reset, if the resetting and notification sound stops incompletely, restart the resetting procedure again.
  - Make sure that there is no objects around the driver's seat in advance of resetting the integrated memory system.
  - After resetting the integrated memory system, the adjustment for the driver seat must be stored again to recall the memory position.
- 

**Seat Easy Access**

Seat easy access will move the driver's seat automatically as follows:

- Exiting the vehicle:
  - The driver's seat will move as follows when the Start/Stop button is in the OFF position with the gear in P (Park) and the driver's door open.
    - Driver seat: Moves rearward depending on the distance selected from the Settings menu in the infotainment system.
  - However, the driver's seat may not move rearward if there is not enough space between the driver's seat and the rear seats.
- Entering the vehicle:
  - The driver's seat will move as follows when the Start/Stop button is pressed to the ACC, ON or START position or while carrying the smart key, the driver's door is closed with the Start/Stop button in the OFF position.
    - Driver seat: Moves back to its original position.
- You can set the 'Seat Easy Access' function from the Settings menu in the infotainment system. Select:
  - Driver seat
    - Setup > Vehicle > Seat > Seating Easy Access > Driver Seat Easy Access > Extended/Normal/Off**

**i Information**

The infotainment system may change after software updates. For more information, refer to the user's manual provided in the infotainment system and the quick reference guide.

---

## Steering Wheel

### Motor Driven Power Steering (MDPS)

The system assists you with steering the vehicle. If the vehicle is turned off or if the power steering system becomes inoperative, you may still steer the vehicle, but it will require increased steering effort.

If you notice any change in the effort required to steer during normal vehicle operation, have the system inspected by an authorized HYUNDAI dealer.

#### CAUTION

If Motor Driven Power Steering does not operate normally, the  warning light and the message '**Check motor driven power steering**' will illuminate on the instrument cluster. You may steer the vehicle, but it will require increased steering efforts. Take the vehicle to an authorized HYUNDAI dealer and have the system inspected as soon as possible.

#### Information

During normal vehicle operation:

- The steering effort may be high immediately after pressing the Start/Stop button to the ON position. This happens as the system performs the MDPS system diagnostics. When the diagnostics are completed, the steering wheel effort will return to its normal condition.
- When the 12 V battery voltage is low, you might have to put more steering effort. However, it is a temporary condition so that it will return to normal condition after charging the battery.
- A click noise may be heard from the MDPS relay after the Start/Stop button is in the ON or OFF position.

- Motor noise may be heard when the vehicle is at a stop or at a low driving speed.
- When you operate the steering wheel in low temperatures, abnormal noise may occur. If the temperature rises, the noise will disappear. This is a normal condition.
- When an error is detected from MDPS, the steering effort assist function will not be activated in order to prevent fatal accidents. Instrument cluster warning lights may be on or the steering effort may be high. If these symptoms occur, drive the vehicle to a safe area as soon as it is safe to do so. Have the system inspected by an authorized HYUNDAI dealer as soon as possible.

### Tilt/Telescopic Steering

When adjusting the steering wheel to a comfortable position, adjust the steering wheel so that it points toward your chest, not toward your face. Make sure you can see the instrument cluster warning lights and gauges. After adjusting, push the steering wheel both up and down to be certain it is locked in position.

Always adjust the position of the steering wheel before driving.

#### WARNING

NEVER adjust the steering wheel while driving. This may cause loss of vehicle control resulting in an accident.

#### NOTICE

While adjusting the steering wheel height, please do not push or pull it hard since the fixture can be damaged.

## Manual adjustment



To adjust the steering wheel angle and height:

1. Pull down the lock-release lever (1).
2. Adjust the steering wheel to the desired angle (2) and distance forward/back (3).
3. Pull up the lock-release lever to lock the steering wheel in place.

### **i** Information

Sometimes the lock-release lever may not engage completely. Pull down on the lock-release lever, readjust the steering wheel again, and then pull back up on the lock-release lever to lock the steering wheel in place.

## Horn



To sound the horn, press the area indicated by the horn symbol on your steering wheel (see illustration). The horn will operate only when this area is pressed.

### **NOTICE**

Do not strike the horn severely or hit it with your fist. Do not press on the horn with a sharp-pointed object.

## Heated Steering Wheel

**+** if equipped

Infotainment system

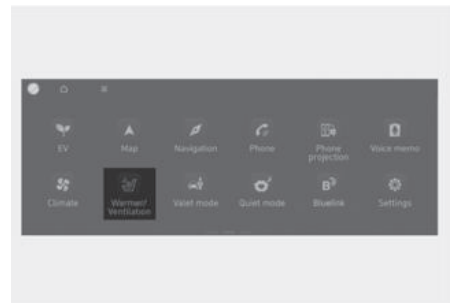

While the vehicle is running, touch Heating/Ventilation icon in the infotainment system.

Climate control panel

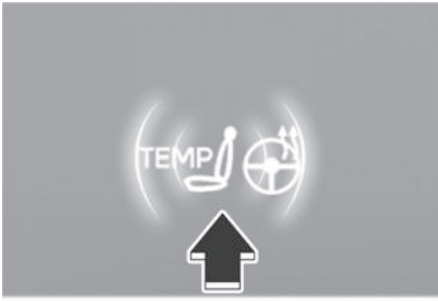

Press  in the front climate control panel.



While the vehicle is running, touch the heated steering wheel icon to warm the steering wheel.

- To warm the steering wheel, touch the heated steering wheel icon in the Heating/Ventilation seats.
- Auto. Controls That Use Climate Control Settings (for driver's seat)

The heated steering wheel automatically controls the steering wheel temperature depending on the ambient temperature when the vehicle is running.

To use this function, it must be enabled from the Settings menu in the infotainment system.

Select **Setup > Vehicle > Seat > Warmer/Ventilation Features > Link to Climate Settings for Auto-Adjustment > Steering Wheel Warmer.**

### Information

The infotainment system may change after software updates. For more information, refer to the user's manual provided in the infotainment system and the quick reference guide.

- The heated steering wheel defaults to the OFF position whenever the Start/Stop button is pressed to the ON position. However, if the Auto. Controls That Use Climate Control Settings function is ON, the heated steering wheel will turn on and off depending on the outside temperature.

### NOTICE

- Do not install any cover or accessories on the steering wheel to prevent damage to the steering wheel heater system.
- Do not strike the steering wheel surface with a sharp-pointed object. This may damage the heating element in the steering wheel.
- Do not clean the steering wheel surface using the following products.
  - Organic solvents such as thinner, alcohol and gasoline
  - Chemical products such as leather cleaner, coating agent, and wax

## Mirrors

### Inside Rearview Mirror

Before driving your vehicle, check to see that your inside rearview mirror is properly positioned. Adjust the rearview mirror so that the view through the rear window is properly centered.

#### WARNING

Make sure your line of sight is not obstructed. Do not place objects on the rear seat or in the cargo area that may interfere with your vision through the rear window.

#### WARNING

To prevent serious injury during an accident or deployment of the airbag, do not modify the rearview mirror and do not install a wide mirror.

#### WARNING

NEVER adjust the mirror while driving. This may cause loss of vehicle control resulting in an accident.

#### NOTICE

When cleaning the mirror, use a paper towel or similar material dampened with glass cleaner. Do not spray glass cleaner directly on the mirror as this may cause the liquid cleaner to enter the mirror housing.

### Day/night rearview mirror

 if equipped



Make this adjustment before you start driving and while the day/night lever is in the day position.

Pull the day/night lever towards you to reduce glare from the headlights of the vehicles behind you during night driving.

Remember that you lose some rearview clarity in the night position.

### Electric Chromic Mirror (ECM)

 if equipped



[A] Indicator

Some vehicles come equipped with an electrochromic mirror that helps control glare while driving at night or under low light driving conditions.

When the vehicle is running, the glare is automatically controlled by the sensor mounted in the rearview mirror. The sensor detects the light level around the vehicle, and automatically adjusts to control the headlight glare from vehicles behind you.

Whenever the gear is shifted to R (Reverse), the mirror will automatically go to the brightest setting in order to improve the driver's view behind the vehicle.

### **Electrochromic mirror (ECM) with HomeLink® system**

**+** if equipped

Your vehicle may be equipped with a Gentex Automatic-Dimming Mirror with an Integrated HomeLink® Wireless Control System.

During nighttime driving, this feature will automatically detect and reduce rearview mirror glare. The HomeLink® Universal Transceiver allows you to activate your garage door(s), electric gate, home lighting, etc.

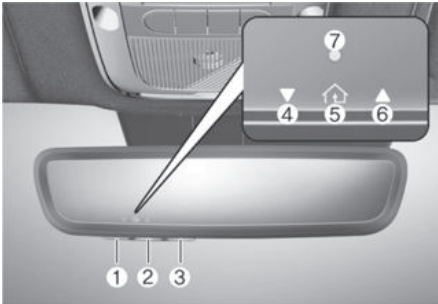

- (1) HomeLink Channel 1
- (2) HomeLink Channel 2
- (3) HomeLink Channel 3
- (4) Garage Door Opener Status Indicator: Closing or Closed
- (5) HomeLink Operation Indicator
- (6) Garage Door Opener Status Indicator: Opening or Opened
- (7) HomeLink User Interface Indicator

### **Automatic-Dimming Night Vision Safety™ (NVS®) Mirror**

**+** if equipped

The NVS® Mirror automatically reduces glare by monitoring light levels in the front and the rear of the vehicle. Any object that obstructs either light sensor will degrade the automatic dimming control feature.

For more information regarding NVS® mirrors and other applications, please refer to the Gentex website:

[www.gentex.com](http://www.gentex.com)

Your mirror will automatically dim upon detecting glare from the vehicles traveling behind you.

The mirror defaults to the ON position each time the vehicle is started.

### **Integrated HomeLink® Wireless Control System**

The HomeLink® Wireless Control System provides a convenient way to replace up to three hand-held radio-frequency transmitters used to activate compatible devices such as gate operators, garage door openers, entry door locks, security systems, and home lighting.

#### **NOTICE**

HomeLink® operates while the Start/Stop button is in the ACC or ON position for safety reasons. It is to prevent unintentional security problems from happening when the vehicle is parked outside the garage.

## WARNING

Before programming HomeLink® to a garage door opener or gate operator, make sure people and objects are out of the way of the device to prevent potential harm or damage. Do not use the HomeLink® with any garage door opener that lacks the safety stop and reverse features required by U.S. federal safety standards (this includes any garage door opener model manufactured before April 1, 1982). A garage door that cannot detect an object—signaling the door to stop and reverse—does not meet current U.S. federal safety standards. Using a garage door opener without these features increases the risk of serious injury or death.

For more information, contact HomeLink® at [www.homelink.com](http://www.homelink.com), or call Home-Link customer support at 1-800-355-3515.

It is also recommended that a new battery be replaced in the hand-held transmitter of the device being trained to HomeLink® for quicker training and accurate transmission of the radio frequency.

### 1. Programming HomeLink®

The following steps show how to program HomeLink. If you have any questions or are having difficulty programming your HomeLink buttons, refer to the HomeLink website or call the HomeLink customer support toll-free number. Do this, before going back to the dealer who sold you the vehicle.

- Visit the HomeLink website at: [www.homelink.com](http://www.homelink.com). Then at the top of the page, choose your vehicle make. Then watch the You Tube video, and/or access additional website information.
- If you choose to access the website via your cell phone, scan the QR code.

- Or, call HomeLink customer support at 1-800-355-3515 (Please have the vehicle make/model AND the opener device make/model readily available.)

### 1) Programming Preparation

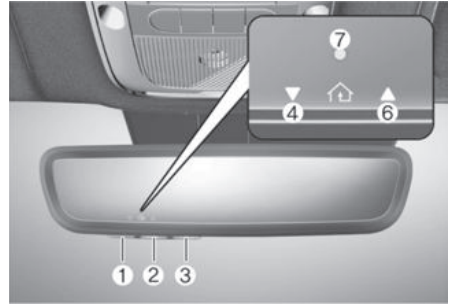

1. When programming a garage door opener, it is advised to park the vehicle outside of the garage.
2. It is recommended that a new battery be placed in the hand-held transmitter of the device being programmed to HomeLink for quicker training and accurate transmission of the radio-frequency signal.
3. Press the Start/Stop button to the ACC (Accessory) position for programming of HomeLink.

### 2) Programming a New HomeLink®

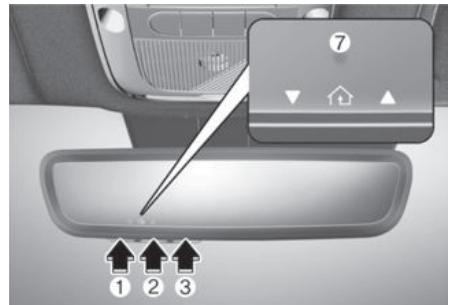

1. Press and release the HomeLink button (1), (2) or (3), you would like to program. The HomeLink indicator light (7) will flash orange slowly (if not, perform the steps of “Erasing HomeLink Buttons” section, and start over).

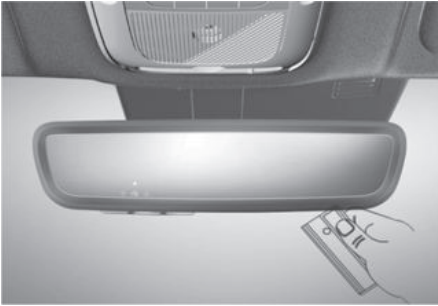

2. Position the garage door opener remote 1-3 in. (2-8 cm) away from the HomeLink buttons.
3. While the HomeLink indicator light (7) is flashing orange, press and hold the hand-held remote button. Continue pressing the hand-held remote button until the HomeLink indicator light (7) light changes from orange to green. You may now release the hand-held remote button.
4. Wait until your garage door comes to a complete stop, regardless of position, before proceeding to the next steps.
5. Press and release the HomeLink button you are programming and observe the indicator light.
  - If the indicator light remains solid green, your device should operate when the HomeLink button is pressed. At this point, if your device operates, programming is complete.
  - If the indicator light rapidly flashes green, firmly press, hold for two seconds and release the HomeLink button up to three times in a row slowly to complete the programming process. Do not press the HomeLink button rapidly. At this point if your device operates, programming is complete. If the device does not operate, continue with step 6.

6. At the garage door opener motor, (security gate motor, etc.) locate the 'Learn', 'Smart', 'Set' or 'Program' button. This can usually be found where the hanging antenna wire is attached to the motor-head unit (see the device's manual to identify this button). The name and color of the button may vary by manufacturer.

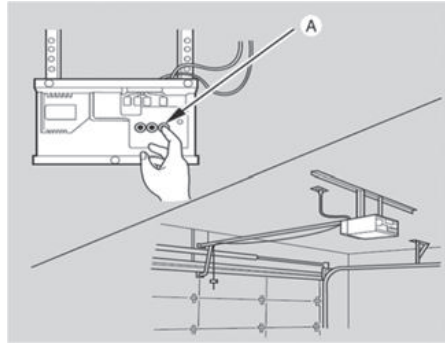

- A ladder and/or second person may simplify the following steps.
7. Firmly press and release the 'Learn', 'Smart', 'Set' or 'Program' button. You now have up to 30 seconds in which to complete the next step.
  8. Return to the vehicle and firmly press, hold for two seconds and release, the HomeLink button up to three times in a row slowly. Do not press the HomeLink button rapidly. As soon as you see the garage door start to move, stop pressing any buttons until a few seconds after the garage door has come to a complete stop, regardless of position. At this point, programming is complete and your device should operate when the HomeLink button is pressed and released.



### 3) Two-Way Communication Programming (For select garage door openers)

If your garage door opener has the 'myQ' logo on its side, your opener likely has Two-Way Communication capability. HomeLink has the capability to establish Two-Way Communication with your garage door opener. HomeLink can receive and display "closing" or "opening" status messages from compatible garage door openers. At any time, Home-Link can also recall and display the last recorded status communicated by the garage door opener to indicate your garage door being "closed" or "opened".

To check if your garage door opener is compatible with this feature, refer to [www.homelink.com/compatible/Two-way-Communication](http://www.homelink.com/compatible/Two-way-Communication). If your garage door opener has this functionality, AND the Two-Way Communication indicators (4), (6) in the mirror appear while the garage door is opening/closing, then no further steps are needed. Two-Way Communication Programming is already complete. However, if your garage door opener has this functionality, AND the Two-Way Communication indicators (4), (6) in the mirror DO NOT appear while the garage door is opening/closing, use the following instructions to enable this functionality.

1. In your vehicle, press and hold the programmed HomeLink button for 2 seconds, then release. Confirm that the garage door is moving. AFTER it stops, you will have one minute to complete the following steps:
  - A ladder and/or second person may simplify the following steps.

2. On your garage door opener in your garage, locate the 'Learn' button (usually near where the hanging antenna wire is attached to the garage door opener). If there is difficulty locating this button, reference the device's owner's manual.
3. Press and release the 'Learn' button.
4. A light on your garage door opener may flash, and your Two-Way Communication indicators (4), (6) in your vehicle may flash, confirming completion of the process.
5. Return to the vehicle and firmly press and release the programmed HomeLink button to activate your garage door. The Two-Way Communication indicators (4), (6) flash in orange when the door is moving. Do not make any additional button presses until AFTER the garage door has come to a complete stop.
6. Your Two-Way Communication programming is now complete.

#### *i* Information

If your garage door opener has Two-Way Communication functionality, it is possible for HomeLink to stop functioning the garage door shortly after initial programming, IF the Two-Way Communication Programming wasn't properly completed. This usually happens after the first 10 times a programmed HomeLink button is pressed. If you experience this, completing the "Programming a New HomeLink Button" and "Two-Way Communication Programming" will restore door operation.

#### 4) Canadian Programming

Canadian radio-frequency laws require transmitter remote signals to “time-out” (or quit) after a couple seconds of transmission, which may not be long enough for HomeLink to pick up the signal during programming.

If you live in Canada or you are having difficulties programming a gate operator or garage door opener by using the programming procedures, replace “Programming a New HomeLink Button” step 3 with the following:

While the HomeLink indicator light (7) is flashing orange, press and release (“cycle”) your device's hand-held remote every two seconds until the HomeLink indicator light (7) changes from orange to green. You may now release the hand-held remote button. Then proceed with “Programming a New HomeLink Button” step 4.

### 2. Operating HomeLink®

#### 1) Operating HomeLink®



1. Press and release the desired programmed HomeLink button (1, 2 or 3).

### *i* Information

The HomeLink indicator (7) should light green, solid or flashing, and your programmed device should operate.

If your device does not operate, the HomeLink programming was not successful, and you'll need to reprogram the button.

#### 2) Two-Way Communication Display Behavior



1. Press and release one of the programmed HomeLink buttons (1, 2 or 3).



2. The indicator (4) and (6) operates as below, if your garage door opener has Two-Way Communication functionality.

- If the indicator (4) flashes in Orange, it indicates that the garage door is “Closing”.
- The indicator (4) turns solid green once the garage door has closed.
- If the indicator (6) flashes in Orange, it indicates that the garage door is “Opening”.
- The indicator (6) turns solid green once the garage door has fully opened.
- If the indicator (4) or (6) does not turn to green, it indicates that the last status of garage door was not received properly. The HomeLink mirror tries to receive the last known status of the garage door for a few seconds.

### 3) Recalling Garage Door Status

HomeLink mirror with Two-Way Communication provides a way to view the last stored message from the garage door opener. In order to recall the last known status of the last activated device, press the buttons “1 and 2” or “2 and 3” simultaneously.

- If the indicator (4) appears solid Green, it indicates that the last activated device was “closed” properly.
- If the indicator (6) appears solid Green, it indicates that the last activated device was “open” properly.

### 3. Erasing HomeLink® Buttons

#### 1) Erasing and Reprogramming a Single HomeLink® Button:

1. Press and hold the desired HomeLink button you want to re-program. DO NOT release the button.
2. The HomeLink indicator light (7) will illuminate solid green. Release the button as soon as the HomeLink indicator light (7) begins to flash orange, usually about 20 seconds.

3. Proceed with the steps in the “Programming a New HomeLink Button” section.

#### *i* Information

If you do not complete the re-programming of a new device to the button, it will revert to the previously stored programming.

#### 2) The following instructions will erase ALL HomeLink® programming from ALL buttons:

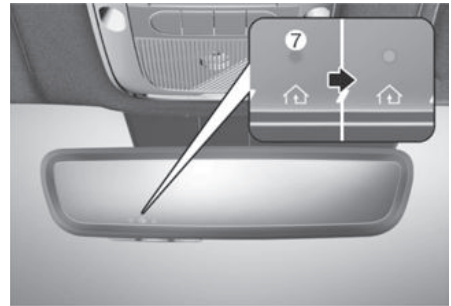

1. Press and hold the buttons (1) and (3) simultaneously
2. The HomeLink indicator light (7) will illuminate solid Orange for about 10 seconds
3. Release the buttons once the HomeLink indicator light (7) changes to Green and flashes rapidly
4. Now all three HomeLink buttons (1), (2) and (3) are cleared of any programming

#### *i* Information

HomeLink® and the HomeLink® House logo are registered trademarks of Gentex Corporation.

The myQ logo is a registered trademark of The Chamberlain Group, Inc.

### **FCC (USA) and ISED (Canada)**

This device complies with FCC rules part 15 and Innovation, Science, and Economic Development Canada RSS-210. Operation is subject to the following two conditions: (1) This device may not cause harmful interference, and (2) This device must accept any interference that may be received including interference that may cause undesired operation. **WARNING:** The transmitter has been tested and complies with FCC and ISED rules. Changes or modifications not expressly approved by the party responsible for compliance could void the user's authority to operate the device.

This equipment complies with FCC and ISED radiation exposure limits set forth for an uncontrolled environment. End Users must follow the specific operating instructions for satisfying RF exposure compliance. This transmitter must be at least 20cm from the user and must not be co-located or operating in conjunction with any other antenna or transmitter.

Cet appareil est conforme aux règlements de la FCC, section 15, et au CNR-210 d'Innovation, Sciences et Développement économique Canada. Le fonctionnement est assujéti aux deux conditions suivantes: (1) cet appareil ne doit pas causer d'interférences nuisibles et (2) cet appareil doit accepter toute interférence reçue, y compris celle qui pourrait entraîner un dysfonctionnement. **MISE EN GARDE:** L'émetteur a subi des tests et est conforme aux règlements de la FCC et d'ISDE. Les changements ou modifications non approuvés explicitement par la partie responsable de la conformité pourraient rendre caduque l'autorisation de l'utilisateur de se servir du dispositif.

Cet appareil est conforme aux limites d'exposition aux radiations de la FCC et d'ISDE établies pour un environnement non contrôlé. Les utilisateurs finaux doivent respecter les instructions d'utilisation spécifiques pour satisfaire aux exigences de conformité aux expositions de RF. L'émetteur doit se trouver à 20 cm au minimum de l'utilisateur et ne doit pas être situé au même endroit que tout autre émetteur ou antenne ni fonctionner avec un autre émetteur ou antenne.

### HomeLink 5 Programing Flow Chart

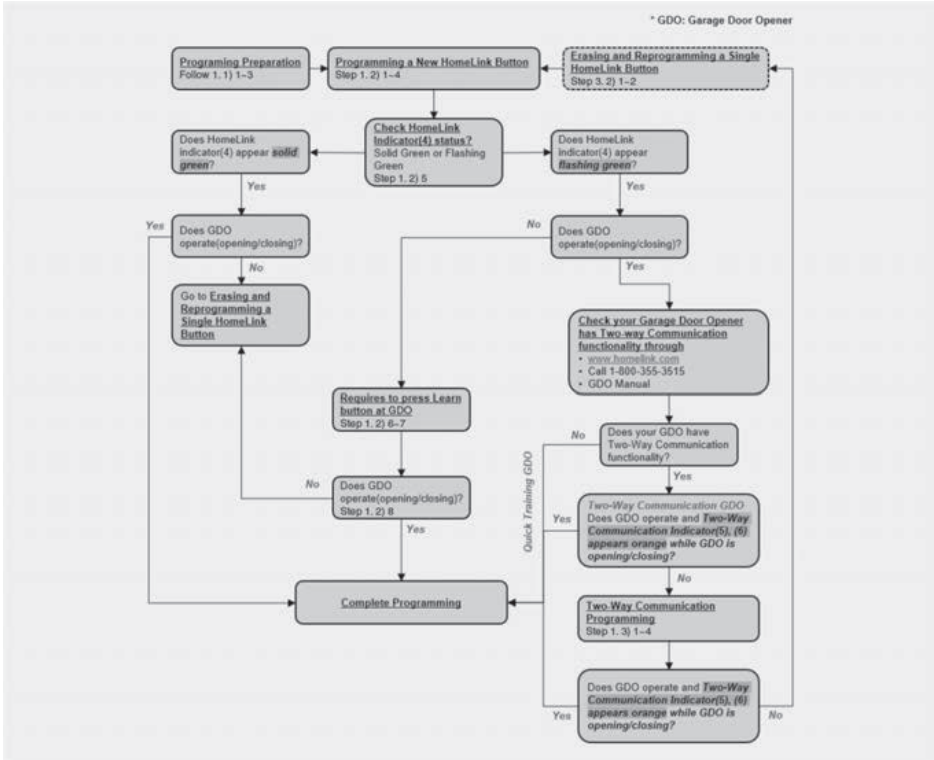

## Side View Mirrors

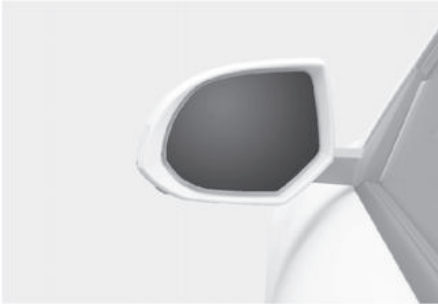

Your vehicle is equipped with both left-hand and right-hand side view mirrors. The mirrors can be adjusted remotely with mirror adjustment control switch. Adjust the side view mirrors to your desired position before driving. The side view mirrors can be folded manually to help prevent damage when going through an automatic car wash or when passing through a narrow street.

Make sure to adjust the side view mirrors to your desired position before you begin driving.

### WARNING

The right side view mirror is convex. Objects seen in the mirror are closer than they appear.

Use the side view mirror or turn your head and look to determine the actual distance of other vehicles prior to changing lanes.

### WARNING

Do not adjust or fold the side view mirrors while driving. This may cause loss of vehicle control resulting in a collision.

## NOTICE

- Do not scrape ice off the mirror face. This may damage the surface of the glass.
- If the mirror is jammed with ice, do not adjust the mirror by force. Use an approved de-icer (not radiator antifreeze) spray, or a sponge or soft cloth with very warm water, or move the vehicle to a warm place and allow the ice to melt.
- Do not clean the mirror with harsh abrasives, fuel, or other petroleum based cleaning products.

## Adjusting the side view mirrors

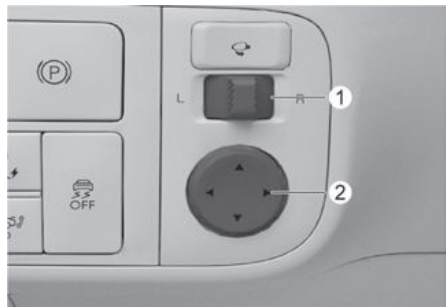

Adjusting the side view mirrors:

1. When the Start/Stop button is in the ACC, ON or START position, move either the L (Left side) or R (Right side) button (1) to select the side view mirror you would like to adjust.
2. Use the mirror adjustment control switch (2) to position the selected mirror up, down, left or right.
3. After adjustment, move the lever (1) to the middle to prevent unintended adjustment.

**NOTICE**

- The mirrors stop moving when they reach the maximum adjusting angles, but the motor continues to operate while the switch is pressed. Do not press the switch longer than necessary, because this can damage the motor.
- Do not attempt to adjust the side view mirrors by hand, because this can damage the motor.

**Folding the side view mirrors****Folding button**

Press the button to fold or unfold the side view mirrors.

**Infotainment system setting**

- Enable on door unlock  
If **Setup > Vehicle > Lights > Welcome Mirror/Light > Enable on Door Unlock** is selected from the Settings menu in the infotainment system,
- The mirror will fold or unfold when the door is locked or unlocked by the smart key.
- The mirror will fold or unfold when the door is locked or unlocked by the touch sensor or button on the outside door handle.

- Enable on driver approach  
If **Setup > Vehicle > Lights > Welcome Mirror/Light > Enable on Driver Approach** is selected from the Settings menu in the infotainment system, the mirror will unfold when the vehicle is approached with the smart key in possession.

**i Information**

The infotainment system may change after software updates. For more information, refer to the user's manual provided in the infotainment system and the quick reference guide.

**NOTICE**

For your safety, the side view mirrors cannot be folded automatically when driving at a speed of 9 mph (15 km/h) or faster.

**NOTICE**

The electric type side view mirror operates even though the Start/Stop button is in the OFF position. However, to prevent unnecessary battery discharge, do not adjust the mirrors longer than necessary while the vehicle is turned off (**READY** indicator off).

**NOTICE**

Do not fold the electric type side view mirror by hand. It could cause motor failure.

## Reverse Parking Aid

 If equipped



When the gear is shifted to the R (Reverse) position, the side view lever(s) will rotate downwards to aid with driving in reverse.

The state of the side view mirror lever (1) determines whether or not the mirrors will move:

How it works

- Left/Right: When either the L (Left) or R (Right) lever is selected, both side view mirrors will move.
- Neutral: When neither switch is selected, the side view mirrors will not move.

The side view mirrors will automatically revert to their original positions if any of the following occur:

- The Start/Stop button is pressed to either the OFF position or the ACC position.
- The gear is shifted to any position except R (Reverse).
- The side view mirror adjustment button is not selected.

### **Reverse parking aid user settings mode**

You may change the angle of the side view mirror if it is difficult to see the rear view with the basic downward mirror angle provided when reversing.

When the vehicle is first delivered, the set downward angle of the left and right side view mirror are different to ensure driver visibility.

1. Make sure the vehicle is stopped.
2. Depress the brake pedal and shift the gear to R (Reverse). When L (Left) or R (Right) lever is selected, both side view mirror angle will move downward to the basic set position.
3. Move either L or R lever to select the side view mirror you would like to adjust. Then press “▼, ▲, ◀, ▶” switch to adjust the side view mirror to the desired angle.
4. After adjusting the angle to save the adjusted side view mirror angle, shift the gear to another position other than R (Reverse), or change the L and R levers to the neutral position (L and R levers are not selected).
5. Set the other side view mirror following the above procedure 1 to 4.

### **Resetting reverse parking aid user settings mode**

To change the side view mirror angle back to the basic angle, shift the gear to R (Reverse), and adjust the mirror angle higher than when the gear is in P (Park), N (Neutral) and D (Drive).

### **NOTICE**

When changing the angle of both side view mirrors, it is recommended to change the angle one side at a time following the procedure 1 to 4.



## Windows

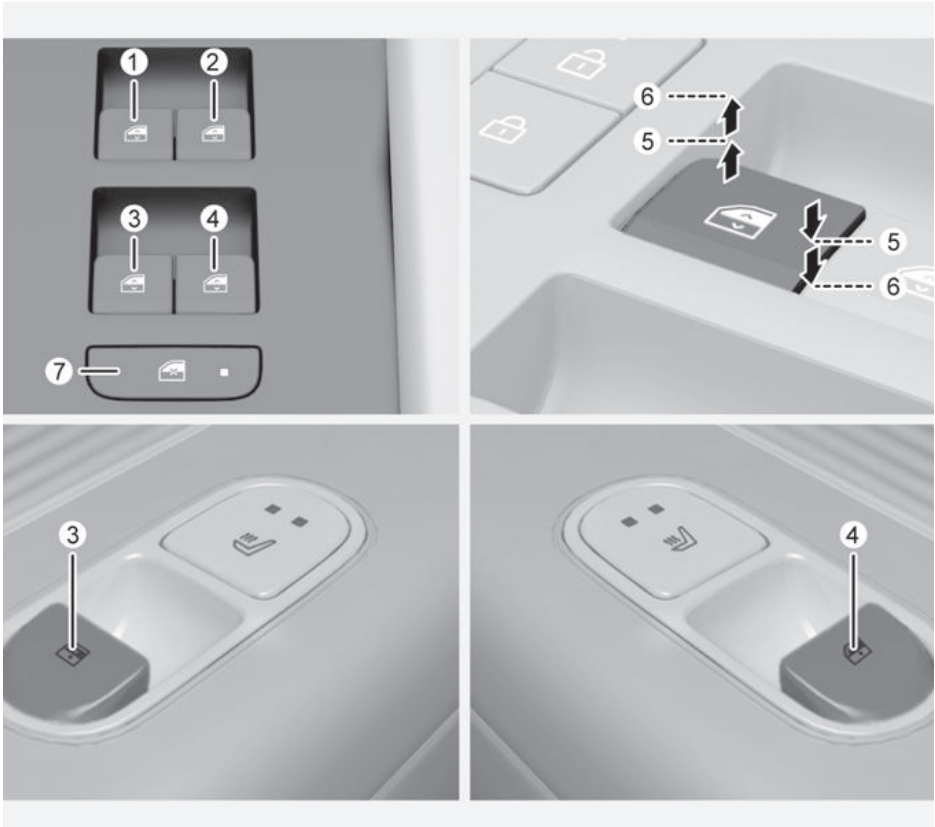

- (1) Driver's door power window switch
- (2) Front passenger's door power window switch
- (3) Rear door (left) power window switch
- (4) Rear door (right) power window switch
- (5) Window opening and closing
- (6) Automatic power window
- (7) Power window lock switch

## Power Windows

The Start/Stop button must be in the ON position to be able to raise or lower the windows. The front door window power window switch is located on the center console along with the power window lock button which can block the operation of rear passenger windows. The power window switch for the rear door windows are on the rear doors. The power windows will operate for about 3 minutes after the Start/Stop button is in the ACC or OFF position. However, if the front doors are opened, the power windows will not operate even within the 3 minute period.

### Window opening and closing

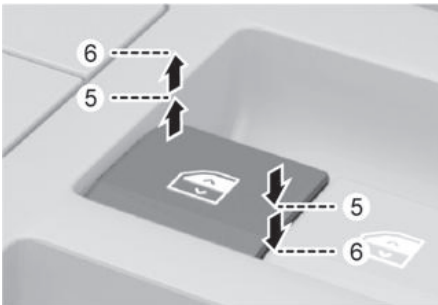

To open:

Press the window switch down to the first detent position (5). Release the switch when you want the window to stop.

To close:

Pull the window switch up to the first detent position (5). Release the window switch when you want the window to stop.

### Auto up/down window

Pressing the power window switch momentarily to the second detent position (6) completely lowers or lifts the window even when the switch is released. To stop the window at the desired position while the window is in operation, pull up or press down and release the switch.

#### **! WARNING**

- Do not leave the vehicle turned on (READY indicator on) and the key in your vehicle with unsupervised children. Unattended children could operate the window, which could result in serious injury.
- Do not extend your head, arms, body parts or objects outside the window while driving.

### Resetting the power windows

If the power windows do not operate normally, the automatic power window system must be reset as follows:

1. Press the Start/Stop button to the ON position.
2. Close the window and continue pulling up on the power window switch for at least one second.

If the power windows do not operate properly after resetting, have the system inspected by an authorized HYUNDAI dealer.

#### **! WARNING**

The automatic reverse feature doesn't activate while resetting the power window system.

### Automatic reverse

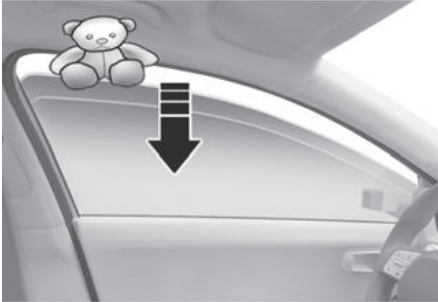

If a window senses any obstacle while it is closing automatically, it will stop and lower about 12 in. (30 cm) to allow the object to be cleared.

If the window detects the resistance while the power window switch is pulled up continuously, the window will stop upward movement then lower about 1 in. (2.5 cm).

If the power window switch is pulled up continuously again within 5 seconds after the window is lowered by the automatic window reverse feature, the automatic window reverse will not operate.

#### **i** Information

The automatic reverse feature is only active when the “Auto Up” feature is used by fully pulling up the switch to the second detent.

#### **!** WARNING

Make sure body parts or other objects are safely out of the way before closing the windows to avoid injuries or vehicle damage.

Objects less than 0.16 in. (4 mm) in diameter caught between the window glass and the upper window channel may not be detected by the automatic reverse window and the window will not stop and reverse direction.

### Power window lock button

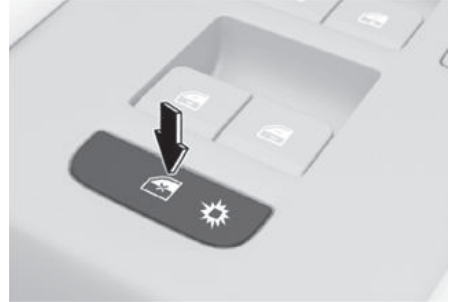

The driver can disable the power window switches on the rear passenger doors by pressing the power window lock button. When the power window lock button is pressed:

- The driver's master control can operate all the power windows.
- The front passenger's control can operate the front passenger's power window.
- The rear passenger's control cannot operate the rear passengers' power window.

#### **!** WARNING

Do not allow children to play with the power windows. Keep the driver's door power window lock button in the LOCK position. Serious injury or death can result from unintentional window operation by a child.

#### **NOTICE**

- To prevent possible damage to the power window system, do not open or close two windows or more at the same time. This will also ensure the longevity of the fuse.

- Never try to operate the main switch on the driver's door and the individual door window switch in opposite directions at the same time. If this is done, the window will stop and cannot be opened or closed.

### Remote window opening function

 If equipped

Type A



Type B



Press and hold the Door Unlock (1) button on the smart key for more than 3 seconds and the windows move down after the doors are unlocked. Window movement stops when you release the door unlock button.

### *i* Information

- The remote window opening function will be operated only with the Safety Power Windows equipped.
- The remote window opening function may abruptly stop when you move away from your vehicle during operation. Stay in close proximity from your vehicle, while monitoring the window movement.
- Please be aware that the doors unlock when the windows are opened using the remote window open function.

## Wide Sunroof

 if equipped

If your vehicle is equipped with a sunroof, you can slide or tilt your sunroof with the sunroof switch located on the overhead console.



The sunroof can only be operated when the Start/Stop button is in the ON or START position.

The sunroof can be operated for about 3 minutes after the Start/Stop button is in the ACC or OFF position. However, if the front door is open, the sunroof cannot be operated even within the 3 minute period.

### WARNING

- Adjust the sunroof or sunshade when your vehicle stops. This could result in loss of control and an accident that may cause injury, or property damage.
- Do not leave the vehicle running and the key in your vehicle with unsupervised children. Unattended children could operate the sunroof, which could result in serious injury.
- Do not sit on the top of the vehicle. It may cause injury or vehicle damage.

### NOTICE

Do not operate the sunroof when roof bars are installed on the vehicle or when there is luggage on the roof.

## Power sunshade

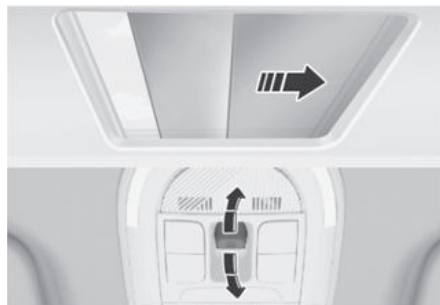

Use the power sunshade to block direct sunlight coming through the sunroof glass.

- Push the sunroof switch rearward to the first detent position, the power sunshade automatically slides open.
- Push the sunroof switch forward to the first detent position, the power sunshade automatically closes. However, if the sunroof glass is open, the glass will close first.

To stop the power sunshade at any point, push the sunroof switch in any direction.

### NOTICE

Do not pull or push the power sunshade by hand as such action may damage the power sunshade or cause it to malfunction.

### *i* Information

Wrinkles formed on the power sunshade are normal due to material characteristic.

### Tilt open/close

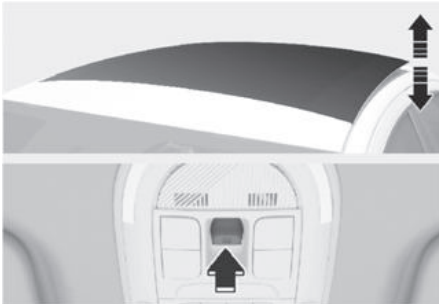

- Push the sunroof switch upward, the sunroof glass tilts open. However, if the power sunshade is closed, the sunshade will open first.
- Push the sunroof switch upward or forward when the sunroof glass is tilt opened, the sunroof glass automatically closes.

To stop the sunroof movement at any point, push the sunroof switch in any direction.

### Slide open/close

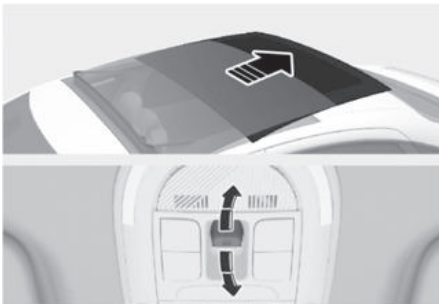

- Push the sunroof switch rearward to the first detent position, the sunroof glass opens. However, if the power sunshade is closed, the power sunshade will open first.

Push the sunroof switch forward to the first detent position, the sunroof glass closes. However, if the sunroof glass is closed, the power sunshade will close.

- Push the sunroof switch forward or rearward to the second detent position, the power sunshade and sunroof glass operate automatically (auto slide feature). To stop the sunroof movement at any point, push the sunroof switch in any direction.

### Automatic reversal

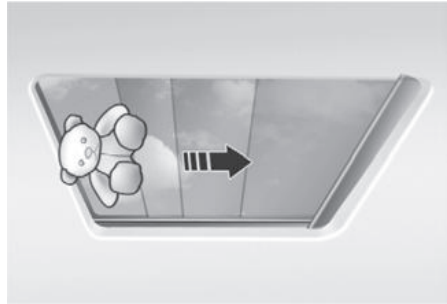

If the power sunshade or sunroof glass senses any obstacle while it is closing automatically, it will reverse direction then stop at a certain position.

The auto reverse function may not work if an object thin or soft is caught between the sliding power sunshade or sunroof glass and sunroof sash.

### WARNING

- Make sure heads, hands, arms or any other body parts or objects are out of the way before operating the sunroof. Body parts or objects may get caught causing injuries or vehicle damage.
- Never deliberately use your body parts to test the automatic reversal function. The power sunshade or sunroof glass may reverse direction, but there is a risk of injury.

**NOTICE**

- Do not continue to push the sunroof switch after the sunroof is fully opened, closed, or tilted. Damage to the sunroof motor could occur.
- Continuous operations such as slide open/close, tilt open/close, etc., may cause the motor or sunroof system to malfunction.
- Regularly remove any accumulated dust on the sunroof rail.
- Dust accumulated between the sunroof and roof panel can make noise. Open the sunroof and remove dust regularly using a clean cloth.
- Do not try to open the sunroof when the temperature is below freezing or when the sunroof is covered with snow or ice. The sunroof may not work properly and may break if opened by force.
- Do not open or drive with the sunroof glass open immediately after rain or washing the vehicle. Water may wet the interior of the vehicle.
- Do not extend any luggage outside the sunroof while driving. Vehicle damage may occur if the vehicle suddenly stops.

**! WARNING**

Do not extend your head, arms, body parts or objects outside the sunroof while driving. Injuries may occur if the vehicle suddenly stops.

**Resetting the sunroof**

In some circumstances resetting the sunroof operation may need to be performed. Some instances where resetting the sunroof may be required include:

- When the 12 V battery is either disconnected or discharged
- When the sunroof fuse is replaced
- If the sunroof one-touch AUTO OPEN/CLOSE operation is not functioning properly

Sunroof resetting procedure:

1. It is recommended to perform the reset procedure with the vehicle running. Start the vehicle in P (Park).
2. Make sure the power sunshade and sunroof glass are in the fully closed position. If the power sunshade and sunroof glass are open, push the switch forward until the power sunshade and sunroof glass are fully closed.
3. Release the switch when the power sunshade and sunroof glass are fully closed.
4. Push the switch forward until the power sunshade and sunroof glass move slightly. Then release the switch.
5. Once again push and hold the sunroof switch forward until the power sunshade and sunroof glass slide open

and close. Do not release the switch until the operation is completed.

If you release the switch during operation, start the procedure again from step 2.

### **i** Information

If the sunroof is not reset after the vehicle battery is disconnected or discharged, or the sunroof fuse is blown, the sunroof may not operate normally.

### **Sunroof open warning**



If the driver turns off the vehicle when the sunroof is not fully closed, the warning chime will sound for several seconds and the sunroof open warning will appear on the cluster display. Close the sunroof securely when leaving your vehicle.

### **⚠ CAUTION**

Make sure the sunroof is closed fully when leaving your vehicle. If the sunroof is left open, rain or snow may wet the interior of the vehicle. Also, leaving the sunroof open when the vehicle is unattended may invite theft.

## Hood

### Opening the Hood



1. Park the vehicle and apply the parking brake.
2. Pull the release lever to unlatch the hood. The hood pops open slightly.

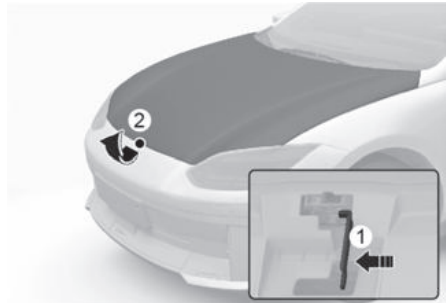

3. Go to the front of the vehicle, raise the hood slightly, push to the left the secondary hood release lever (1) inside of the hood center and lift the hood (2).



## Closing the Hood

1. Before closing the hood, check in and around the motor compartment to ensure the following:
  - Any tools or other loose objects have been removed.
  - All glove, rags, or other combustible material have been removed.
  - All filler caps are tightly and correctly installed
2. Lower the hood until it is about 12 in. (30 cm) above the closed position and then let it drop.
3. Check the hood has locked properly. If the hood is raised slightly, open it again and drop it from a little higher. Check again.

### WARNING

- Before closing the hood, ensure all obstructions are removed from around the hood opening. The hood will rise up or move down automatically if the height is not firmly adjusted. Be aware of the damage caused by the unintended hood movements.
- Always double check to make sure that the hood is firmly latched before driving away. Check there is no hood open warning light or message displayed on the instrument cluster. Driving with the hood open may cause a total loss of visibility, resulting in a collision.
- Do not move the vehicle with the hood raised. It may block your vision and may result in a collision.

## Front Trunk

### Opening the Front Trunk



Opening the hood reveals the front trunk and you can store your belongings.

### Information

Front trunk weight limit: 25 lbs. (10 kg)

The front trunk's weight limit depends on the specifications.

### WARNING

- NEVER make an attempt to get inside the front trunk. It will cause a fatal injury.
- Before closing the hood, ensure all obstructions are removed from around the hood opening. The hood will rise up or move down automatically if the height is not firmly adjusted. Be aware of the damage caused by the unintended hood movements.
- Never store cigarette lighters, propane cylinders, or other flammable/explosive materials in the vehicle. These items may catch fire and/or explode if the vehicle is exposed to hot temperatures for extended periods.

### CAUTION

- Do not exceed the luggage volume capacity of the front trunk. The overweighted front trunk can be severely damaged.
  - Do not store the fragile objects in the front trunk.
  - ALWAYS keep the front trunk cover closed securely while driving. Items inside your vehicle are moving as fast as the vehicle. If you have to stop or turn quickly, or if there is a crash, the items can be damaged.
  - Do not spray water in the front trunk. Vehicle driving system may get damaged since the front trunk is located at the center of motor compartment.
  - Be careful when you store any liquid in the front trunk. If liquid leak outside the front trunk, it will cause damage to the electric devices in the motor compartment.
  - Do not press the front trunk cover or place the objects on the front trunk cover. It may be deformed or damaged.
  - When closing the front trunk cover, be careful not to touch objects inside the trunk. Loaded objects or the front trunk may be deformed or damaged and the front trunk cover may be opened during driving due to poor closing, resulting in joints and damage.
- 

### NOTICE

To avoid possible theft, do not leave valuables in the storage compartments.

---

## Power Trunk

### Power Trunk Operating Conditions

The power trunk operates when vehicle speed is below 1.8 mph (3 km/h).

### WARNING

- Never leave children or animals unattended in your vehicle. Children may operate the power trunk. Doing so can result in injury to themselves or others and can damage the vehicle.
  - Make sure there are no people or objects and enough space around the trunk before operating the power trunk or smart trunk prior to use. Serious injury, damage to the vehicle or damage to surrounding objects (for example, walls, ceilings, vehicles, etc.) may result if contact with the trunk occurs.
  - Make sure there are no people or objects around the trunk before operating the power trunk. Wait until the trunk is opened fully and stopped before loading or unloading cargo from the vehicle.
- 

### NOTICE

- Do not close or open the power trunk manually. This may cause damage to the power trunk. If it is necessary to close or open the power trunk manually when the battery is discharged or disconnected, do not apply excessive force.
- Do not operate the power trunk more than 10 times continuously when the vehicle is turned off (READY indicator off) is off. Use the power trunk with the vehicle turned on (READY indicator on) when the power trunk is used repeatedly to prevent battery discharge.

- Do not leave the trunk open for a long period of time. This may drain the battery.
- Do not modify or repair any part of the power trunk by yourself. Contact an authorized HYUNDAI dealer.
- Do not operate the power trunk under the following conditions. The power trunk may not operate properly.
  - One side of the vehicle is lifted to inspect the vehicle or change a tire
  - Parking on an uneven road such as a slope, etc.
- Close the trunk completely and lock all doors and trunk using the central door lock button before using an automatic car wash.
- Do not spray high pressure water directly on the power trunk outside open/close button. The trunk may open unintentionally.

### **i** Information

- In cold and wet climates, the outside power trunk open button may not work properly due to freezing conditions. If this occurs, remove the ice before using the outside power trunk open/close button or use the power trunk open/close button on the smart key or the instrument panel.
- If you leave the smart key in the trunk and close the trunk, a warning will sound for about 5 seconds. If this occurs, open the trunk by pressing the power trunk open button on the outside of the trunk.
- If there are obstacles such as snow on the trunk, the trunk may not open automatically. After removing the obstacle, try to open it again.
- Be careful where there is an incline, as the trunk lid may drop slightly when it is stopped before it fully opens.

## Operating the Power Trunk

### **Power trunk open button (Smart key)**



When the trunk is closed, press the power trunk open button for 1.5 second. The trunk will open with a warning sound.

While the trunk is opening, press the button to stop power trunk operation.

### **Power trunk open/close button (Instrument panel)**

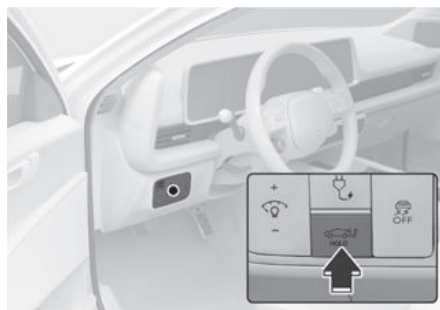

When the trunk is closed, press the power trunk open/close button. The power trunk will open with a warning sound.

While the trunk is opening, press the button to stop power trunk operation.

When the trunk is opened, press and hold the trunk open/close button to close the power trunk. If you release the button while the trunk is closing, power trunk

operation will stop with a warning sound for 5 seconds.

### **Power trunk open button (Outside the power trunk)**

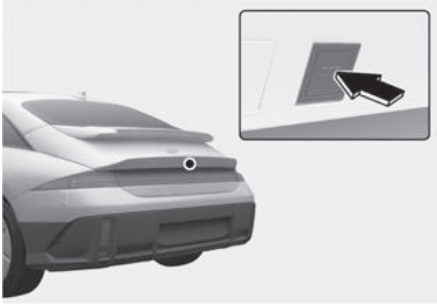

When the trunk is closed, press the power trunk open button to open the trunk.

If the vehicle is locked, press the power trunk open button with the smart key in your possession.

While the trunk is opening, press the button to stop power trunk operation.

### **Power trunk close button (Inside the power trunk)**



Press the power trunk close button. The trunk will close with a warning sound.

While the trunk is closing, press the button to stop power trunk operation.

### **Power trunk lock button (Inside the power trunk)**



Press the power trunk lock button while carrying the smart key. The power trunk will close and lock with a warning sound. Additionally, all doors will lock. The trunk will close and lock, and all doors will lock only when the vehicle is off or all doors are closed.

### **Switching the power trunk from manual to automatic**

If you apply over a certain amount of power manually when the trunk is opened, the power trunk system detects the direction and closes or opens automatically.

- The power trunk fully opens when the trunk is raised.
- The power trunk closes completely when the trunk is lowered.

### ***i* Information**

The power trunk may not operate properly if the trunk is not opened above a certain height.

### Automatic reverse

During power trunk operation if the power trunk senses any obstacle, the trunk will stop or will fully open. The automatic reverse feature may not operate properly, or it may operate unexpectedly under the following circumstances:

- The automatic reverse feature may not detect the resistance if the detected resistance is below a certain level, or if the trunk is almost fully closed near the latched position.
- The automatic reverse feature may operate if a strong impact is applied with no obstructions placed.

#### WARNING

Never intentionally place any object or part of your body in the path of the power trunk to make sure the automatic reverse feature operates. Serious injury, or damage to the vehicle or object may occur.

#### Information

The power trunk may stop operating if the automatic reverse feature operates more than two times while attempting to open or close the trunk. If this occurs, carefully open or close the trunk manually, and then after 30 seconds try to operate the power trunk automatically again.

### Resetting the Power Trunk

To reset the power trunk:

1. With the vehicle is turned off or on (READY indicator off or on), put the gear in P (Park).
2. While Pressing the power trunk close inner button, press the power trunk open outer button for more than 3 seconds. A chime will sound.
3. Slowly close the trunk manually.
4. Press the power trunk open outer button. The trunk will open with a chime sound.

Wait until the trunk fully opens to complete resetting. If the trunk stops before it is fully open, resetting cannot be completed.

#### Information

- If the power trunk is not reset after the vehicle battery is disconnected or discharged, or the power trunk fuse is blown, the power trunk may not operate normally.
- If the power trunk does not operate properly after the above procedure, have the system inspected by an authorized HYUNDAI dealer.

## Emergency Trunk Safety Release



### • Inside the trunk

Your vehicle is equipped with an emergency trunk safety release lever located inside the trunk. When someone is inadvertently locked in the trunk, the trunk can be opened by moving the lever in the direction of the arrow and pushing the trunk lid to open.

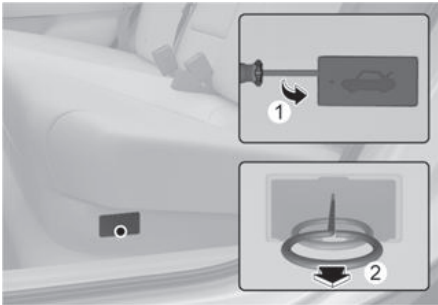

### • Inside the vehicle

Follow the below procedure to open the power trunk manually when the battery is discharged or when there is a problem with the vehicle:

1. Remove the cable cover (1) under the rear seat using a small flat blade tool (like a screwdriver or similar).
2. Pull the cable loop (2) all the way out. The power trunk unlocks.
3. Push the trunk lid to open.

### WARNING

- You and your passengers must be aware of the location of the Emergency Trunk Safety Release lever in this vehicle and how to open the trunk in case you are accidentally locked in the trunk.
- NEVER allow anyone to occupy the trunk of the vehicle at any time.
- Use the release lever for emergencies only.

### NOTICE

Be careful not to scratch or lose the cover when removing it.

### Information

The cable is firmly fixed so it may hard to pull. Therefore, please use a tool such as a screwdriver to assist in pulling the loop for the emergency release.

## Smart Trunk

 if equipped



On a vehicle equipped with a smart key, the trunk can be opened with hands-free activation using the smart trunk system.

### Using Smart Trunk

The hands-free smart trunk system can be used when:

- The smart trunk option is enabled in the Settings menu in the infotainment system.
- The smart trunk is activated 15 seconds after all the doors are closed and locked.
- The smart trunk opens when the smart key is detected in the area behind the vehicle for 3 seconds.
- When disconnecting the charging connector, the smart trunk is activated.

#### *i* Information

The smart trunk does not operate when:

- A door is not locked or closed.
- The smart key is detected within 15 seconds from when the doors were closed and locked.
- The smart key is detected within 15 seconds after the doors are closed and locked, and within 60 in. (1.5 m) from the front door handles. (for vehicles equipped with Welcome Mirror).

- The smart key is in the vehicle.
- The vehicle is on charge.

#### 1. Settings

To use smart trunk, it must be enabled from the Settings menu in the infotainment system.

Select **Setup > Vehicle > Door > Smart Trunk**.

#### *i* Information

The infotainment system may change after software updates. For more information, refer to the user's manual provided in the infotainment system and the quick reference guide.

#### 2. Detect and Alert

The smart trunk detecting area extends about 20-40 in. (50-100 cm) behind the vehicle. If you are positioned in the detecting area and are carrying the smart key, the hazard warning lights blink and the chime sounds before opening.

#### *i* Information

If you unintentionally enter the detecting area and the hazard warning lights and chime starts, move away from the vehicle with the smart key. The trunk remains closed.

#### 3. Automatic opening

After the hazard warning lights blink and the chime sounds 6 times, the smart trunk opens.

## Deactivating smart trunk

Type A

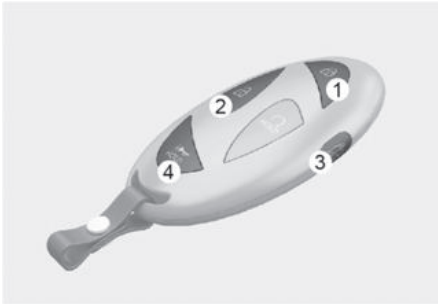

Type B



1. Door lock
2. Door unlock
3. Trunk open/close
4. Panic

If you press any button on the smart key during the Detect and Alert stage, the smart trunk is deactivated.

Using the smart key:

- If you press the door unlock button, the smart trunk is deactivated temporarily. If you do not open any door for 30 seconds, the smart trunk is activated again.
- If you press the trunk open button for more than 1 second, the trunk opens.
- The smart trunk is still activated if you press the door lock button or trunk open/close button as long as the smart trunk is not in the Detect and Alert stage.

## Detecting area

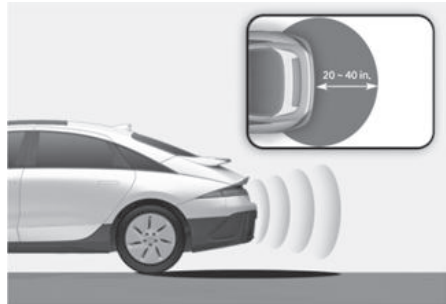

- The smart trunk detecting area extends about 20-40 in. (50-100 cm) behind the vehicle. If you are positioned in the detecting area and are carrying the smart key, the hazard warning lights will blink and the chime will sound for about 3 seconds to alert you that the trunk will open.
- The alert stops once the smart key is moved outside of the detecting area within the 3 second period.

### *i* Information

- Smart trunk may not operate properly if any of the following occur:
  - The smart key is close to a radio transmitter such as a radio station or an airport which can interfere with normal operation of the transmitter.
  - The smart key is near a mobile two way radio system or a mobile phone.
  - Another vehicle's smart key is being operated close to your vehicle.
  - The temperature drops below zero degree.
- Smart trunk detecting area may change when:
  - The vehicle is parked on an incline or slope.
  - One side of the vehicle is raised or lowered relative to the opposite side.



## Electric Charging Door



The driver can open and close the charging door with the following methods:

- When the shift gear is in P (Park), push the charging door to open/close
- Push the Close button located inner part of the charging door
- Use the Voice Recognition

### NOTICE

- If the charging door does not open because ice has formed around it, tap lightly or push on the door to break the ice and release the door. If necessary, use hand temperature to melt down the ice or move the vehicle to a warm place and allow the ice to melt. Do not pry on the charging door or use unauthorized tools to open the charging door.
- After closing the charging door, push the door again to ensure that the charging door is completely closed.
- Make sure that the charging door is closed before driving the vehicle. If the charging door is opened, mechanical parts of the charging door can be damaged.

- After closed the charging door, be sure to check the warning light is off.
- After charging the vehicle, close the charging inlet by the charging inlet cover properly. If the charging inlet cover is closed improperly, the charging inlet and the charging door can be damaged.
- Do not pry on the charging door while the charging door is opening. The charging door may stop moving. Also, the electrical mechanism of the charging door and its related parts can be severely damaged.
- While washing the vehicle, do not spray a high pressure water to the charging door directly. The high pressure can damage the charging door.

### ⚠ CAUTION

- The charging door opens sideways. Check the surrounding while the charging door is open or close. Be aware of your head or limbs from being hit or stuck to the charging door.
- Do not hold the hinge to prevent damaging the charging door and causing other accidents.

## **i** Information

- The charging door automatically closes when:
  - The charging connector is disconnected
  - The door is opened and the charging connector is not connected for a certain period of time
  - The gear is not in P (Park)
- After replacing battery (12 V), open and close the charging door once to check that the charging door automatic opening mechanism is functioning properly.

For more information, refer to the “Charging Your Electric Vehicle” section in chapter 1.

## Head-up Display

**+** if equipped

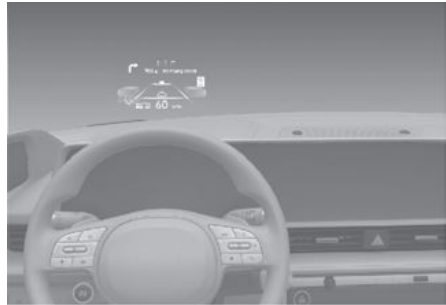

The Head-up display is an optional feature that allows the driver to view information projected onto a transparent screen while still keeping your eyes safely on the road ahead while driving.

## Head-up Display Settings

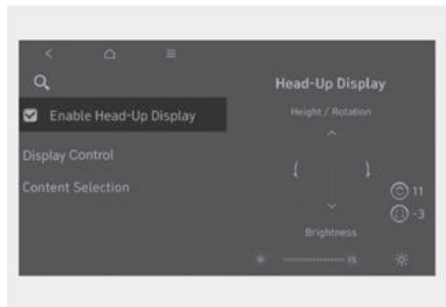

- Head-up display can be enabled from the Settings menu in the infotainment system.  
Select **Setup > Vehicle > Head-Up Display > Enable Head-Up Display**.
- After turning on the Head-up display, you can change the settings of '**Display Control**' and '**Content Selection**' of the Head-Up Display.

## *i* Information

The infotainment system may change after software updates. For more information, refer to the user's manual provided in the infotainment system and the quick reference guide.

## Head-up Display Information



1. Turn by Turn (TBT) navigation
2. Traffic signs or speed limit
3. Speedometer
4. SCC set speed
5. SCC vehicle distance
6. Lane Following Assist
7. Lane Safety
8. Blind-Spot Safety
9. Highway Auto Speed Change
10. Highway Driving Assist
11. Surrounding vehicle (if equipped)

## Precautions while Using the Head-up Display

- It may sometimes be difficult to read information on the Head-up display in the following situations.
  - The driver is improperly positioned in the driver's seat
  - The driver wears polarizing-filter sunglasses
  - An object is located above the head-up display cover
  - The vehicle is driven on a wet road
  - Any improper lighting accessory is installed inside the vehicle, or there is incoming light from outside of the vehicle
  - The driver wears glasses
  - The driver wears contact lenses

When it is difficult to read the head-up display information, adjust the image position or brightness level from the Settings menu in the infotainment system.

- Since the information displayed on the head-up display partially overlaps with the road ahead, you may feel fatigue and discomfort while driving. If you feel tired or uncomfortable, adjust the image, and if the symptoms persist, turn off the head-up display before driving.
- For your safety, make sure to stop the vehicle before adjusting the settings.
- Do not tint the front windshield glass or add other types of metallic coating. Otherwise, the head-up display image may be invisible.
- Do not place any accessories on the dashboard or attach any objects on the windshield glass.
- When replacing the front windshield glass, replace it with a windshield glass designed for head-up display operation. Otherwise, duplicated images may be displayed on the windshield glass.

**WARNING**

- The warning information of Blind-Spot Safety on the Head-Up Display are supplemental. Do not solely depend on them to change lanes. Always take a look around before changing lanes. The driving route guidance display in the augmented reality mode is an auxiliary function. Be sure to check the navigation screen together.
- ALWAYS pay attention on the road while driving when the Head-up display is on.

**i Information**

Head-up display includes GPL, LGPL, MPL and other open source license software. All license notices including related source code are provided at <http://www.mobis.co.kr/opensource/list.do>.

If the driver requests on-board software open source code via [MOBIS\\_OSSrequest@mobis.co.kr](mailto:MOBIS_OSSrequest@mobis.co.kr) within 3 years after buying this product, a CD-ROM or other storage device will be sent with the minimum cost covering storage device cost and delivery cost.

## Over-The-Air Software Update

**+** If equipped

The Over-The-Air software update feature allows you to wirelessly update software to the latest version. Using this feature, you can keep your vehicle system up to date with the latest software.

### Downloading Software

The latest software can be downloaded automatically while driving. After the latest software has been successfully downloaded, you will receive a notification on your phone or the vehicle screen that the software update and ready to install.

### Approving Software Update

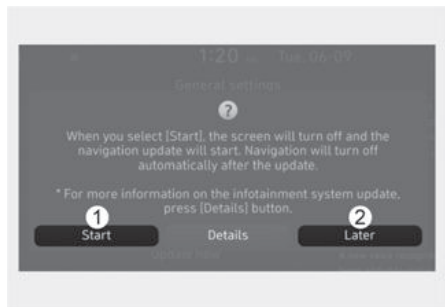

After the vehicle is turned off, the vehicle system will allow you to start the update.

- To start the update, press **'Start'** (1).
- To postpone the update, press **'Later'** (2).

## Preparing Software Update

If you press the **'Start'** button on the screen, the vehicle will begin installing the update automatically. The following conditions must be satisfied:

- The vehicle must be off.
- The gear must be in P (Park).
- The Electronic Parking Brake (EPB) must be applied.
- The exterior lights must be turned off.
- The hood must be closed.
- The battery must be sufficient.
- The systems to be updated must not be running.

### *i* Information

The battery and system status are automatically checked by the vehicle.

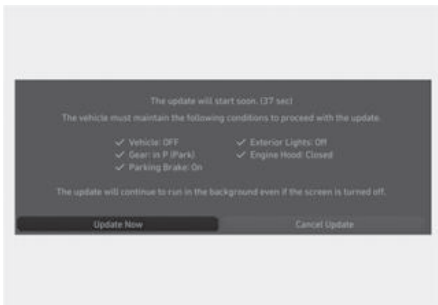

- To update immediately, press **'Update Now'**.
- To cancel the update, press **'Cancel Update'**.

## Updating Software

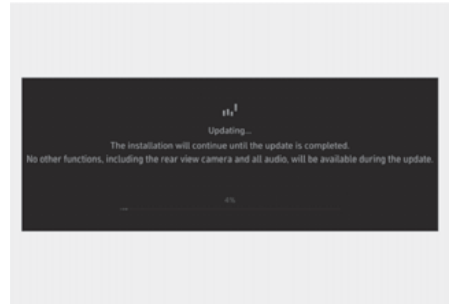

You can see the progress of the update on the screen.

After the update is complete, you will receive a notification on your phone or the vehicle screen that the software update is complete.

### *i* Information

The screen turns off automatically after 3 minutes to save the battery. If the screen turns off automatically, you can check the update progress by pressing the Start/Stop button.

### *i* Information

- After the update starts, you can exit the vehicle.
- The OTA software update feature is only available for HYUNDAI Connected Services users.
- The update details may vary depending on the installed software version.
- Check the notice for the OTA software update on the HYUNDAI brand web.
- If the update fails, the update recovery will automatically proceed. If you want to retry the software update, even after a successful recovery, contact an authorized HYUNDAI Call Center.
- If the update or recovery fails, contact an authorized HYUNDAI Call Center.

- After the update is complete, it may provide new functions or improvements. For more information, see the “Over-The-Air Software Update” page on the HYUNDAI web or scan the QR code on the screen.

### **NOTICE**

- Observe the following restrictions during the update.
    - You cannot use the vehicle during the update. Be sure to have enough time for the update, and safely park the vehicle before starting the update process.
    - You cannot use remote features, including remote start.
    - Vehicle charging is not available. For electrified vehicles, charge the vehicle after the update is completed.
    - Parking video is not recorded. (vehicle with built-in cam)
    - If the update includes the digital key function, the door lock/unlock function via the digital key may not work. If the digital key function is updated by checking the notice, use the button on the smart key to lock or unlock the door.
    - The Rear Occupant Alert feature may not work. Check if there are any occupant in the rear seat. (vehicles with that function)
  - The update will be automatically canceled if any vehicle conditions required for the update are changed before starting the update.
  - Once the update has started, you cannot cancel the update.
  - Note that the high-voltage-related modules for charging the 12 V battery may work during the update. (EV vehicle)
- 
- You cannot use the Over-The-Air software update feature if you modify or replace any vehicle software.
  - Do not open the hood or replace the battery in the vehicle during the update. The update may fail.
  - If a diagnostic tool of any kind is connected to the vehicle OBD (On-board Diagnostic) terminal, the vehicle cannot be updated. The vehicle can be updated by removing the diagnostic tool connected to the OBD terminal and then restarting the vehicle.
  - If the update is not complete successfully, contact HYUNDAI.
  - Vehicle reception must be identified as Verizon to safely install any downloaded software.
  - Vehicle signal strength, must be strong (above -82 dBm) to safely install any downloaded software.
-

## Lighting

### Exterior Lights

#### Lighting control

To operate the lights, turn the knob at the end of the control lever to one of the following positions:

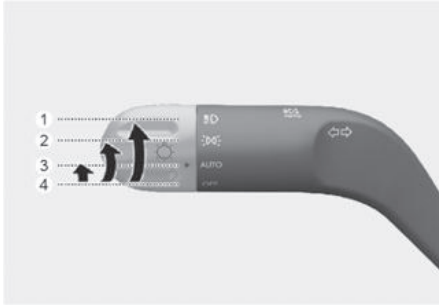

1. OFF
2. AUTO headlight
3. Parking light
4. Headlight

#### Daytime Running Light (DRL)

The Daytime Running Lights (DRL) can make it easier for others to see the front of your vehicle during the day, especially after dawn and before sunset.

The DRL system will turn the dedicated light OFF when:

- The headlights are ON.
- The parking brake is applied.
- The vehicle is turned off.

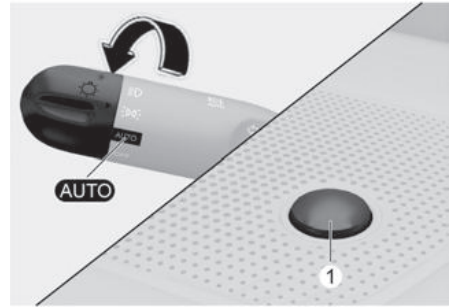

#### AUTO headlight

The parking light and headlight will be turned ON or OFF automatically depending on the amount of daylight as measured by the ambient light sensor (1) at the upper end of the windshield glass.

Even with the AUTO headlight feature in operation, it is recommended to manually turn ON the headlights when driving at night or in a fog, driving in the rain, or when you enter dark areas, such as tunnels and parking facilities.

#### NOTICE

- Do not cover or spill anything on the sensor (1) located at the upper end of the windshield glass.
- Do not clean the sensor using a window cleaner, the cleanser may leave a light film which could interfere with sensor operation.
- If your vehicle window is tinted or other types of metallic coating are on the front windshield, the AUTO headlight system may not work properly.



### Parking light (P)

The parking light, license plate light and instrument panel lamp are turned ON.



### Headlight (H)

The headlight, parking light, license plate light and instrument panel lamp are turned ON.

## **i** Information

The Start/Stop button must be in the ON position to turn on the headlight.

### High beam operation

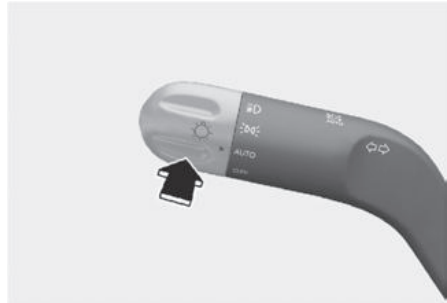

To turn on the high beam headlight, push the lever away from you. The lever will return to its original position.

The high beam indicator will light when the headlight high beams are switched on.

To turn off the high beam headlight, pull the lever towards you. The low beams will turn on.



To flash the high beam headlight, pull the lever towards you, then release the lever. The high beams will remain ON as long as you hold the lever towards you.



## Turn signals and lane change signals

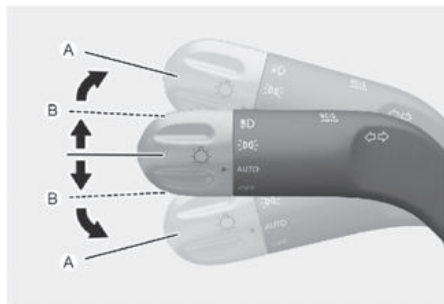

To signal a turn, push down on the lever for a left turn or up for a right turn in position (A).

If an indicator stays on and does not flash or if it flashes abnormally, one of the turn signal bulbs may be burned out and will require replacement.

### One touch turn signal

To use One Touch Turn Signal push the turn signal lever up or down to position (B) and then release it.

The lane change signals will blink 3, 5 or 7 times.

You can enable the One Touch Turn Signal function or choose the number of blinking by selecting **Setup > Vehicle > Lights > One Touch Turn Signal (or One-touch indicator) > 3 flashes/5 flashes/7 flashes/Off** in the infotainment system.

### *i* Information

The infotainment system may change after software updates. For more information, refer to the user's manual provided in the infotainment system and the quick reference guide.

## Battery saver function

To prevent the battery from being discharging, the system automatically turns off the parking lights when the driver turns the vehicle off and opens the driver's door.

To keep the lights on when the vehicle is turned off:

1. Open the driver's door.
2. Turn the parking lights OFF and ON again using the headlight switch.

## Headlight delay function

If the Start/Stop button is in the ACC position or the OFF position with the headlights ON, the headlights (and/or Parking lights) remain on for about 5 minutes. However, if the driver's door is opened and closed, the headlights are turned off after 15 seconds. Also, with the vehicle off if the driver's door is opened and closed, the headlights (and/or Parking lights) are turned off after 15 seconds.

The headlights (and/or Parking lights) can be turned off by pressing the lock button on the smart key twice or turning the headlight switch to the OFF or AUTO position.

You can enable the headlight delay function by selecting **Setup > Vehicle > Lights > Headlight Delay (or Headlight time-out)** in the infotainment system.

### *i* Information

The infotainment system may change after software updates. For more information, refer to the user's manual provided in the infotainment system and the quick reference guide.

### NOTICE

If the driver exits the vehicle through another door besides the driver door, the battery saver function does not operate and the headlight delay function does not turn OFF automatically. This may cause the battery to discharge. To avoid battery discharge, turn OFF the headlights manually from the headlight switch before exiting the vehicle.

## Welcome system

 If equipped



Welcome system helps keep the driver visible by turning on vehicle lights when the driver approaches the vehicle.

### Door handle light

When all the doors (and trunk) are closed and locked, the door handle light will turn on for about 15 seconds if any of the below is performed.

When the door unlock button is pressed on the smart key.

When you put your hand in the outside door handle with the smart key in possession. If **Setup > Vehicle > Lights > Welcome Mirror/ Light > Enable on Driver Approach** is selected from the Settings menu in the infotainment system, the lights will turn on when the vehicle is approached with the smart key in possession.

## i Information

The infotainment system may change after software updates. For more information, refer to the user's manual provided in the infotainment system and the quick reference guide.

### Headlight and parking light

When the light switch is ON, and all the doors (and trunk) are closed and locked, the headlight and parking light will turn on for about 15 seconds if the door unlock button is pressed on the smart key. Note that if the light switch is in the AUTO position, the headlight and parking light will turn on only when it is dark outside.

Select **Setup > Vehicle > Lights > Headlight Delay (or Headlight time-out)** from the Settings menu to turn on this function.

### Interior light

When the interior light switch is in the  position and all doors (and trunk) are closed and locked, the room lamp will come on for 30 seconds if any of the below is performed.

- When the door unlock button is pressed on the smart key.
- When you put your hand in the outside door handle while carrying the Smart key.

At this time, if you press the door lock button on the smart key the lights will turn off immediately.

## Interior Lights

### WARNING

Do not use the interior lights when driving in the dark. The interior lights may obscure your view and cause an accident.

### NOTICE

Do not use the interior lights for extended periods when the vehicle is turned off or the battery will discharge.

## Interior Light AUTO cut

The interior lights will automatically go off about 20 minutes after the vehicle is turned off and the doors are closed. If a door is opened, the light will go off 25 minutes after the vehicle is turned off. If the doors are locked by the smart key and the vehicle enters the armed stage of the theft alarm system, the lights will go off five seconds later.

## Front lamps



### **Front map lamp** (🚗🚗):

Touch either icons to turn the map lamp on or off. This light produces a spot beam for convenient use as a map lamp at night or as a personal light for the driver and the front passenger.

### **Door lamp** (🚗):

The front or rear room lamps come on when the front or rear doors are opened. When doors are unlocked by the smart key, the front and rear lights come on for about 30 seconds as long as any door is not opened. The front and rear room lamps go out gradually after about 30 seconds when the door is closed.

However, if the Start/Stop button is in the ON position or all doors are locked, the front and rear lights will turn off. If a door is opened with the Start/Stop button in the ACC position or the OFF position, the front and rear lights will stay on for about 10 minutes.

### **Room lamp** (🚗):

Press the button to turn ON the room lamp for the front/rear seats.

### **Mood lamp** (🚗):

 if equipped

Press the button to turn On the mood lamp. Press again to turn the lamp off.

## Rear lamps

Room lamp

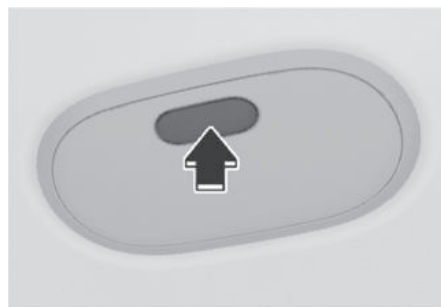



Press the button to turn the lamp on or off.

## Vanity Mirror Lamp



Push the switch to turn the lamp on or off.

- :  
The lamp will turn on if this button is pressed.
- :  
The lamp will turn off if this button is pressed.

### NOTICE

Always have the switch in the off position when the vanity mirror lamp is not in use. If the sunvisor is closed without the light off, it may discharge the battery or damage the sunvisor.

## Glove Box Lamp

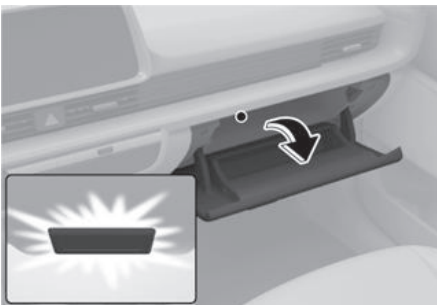

Opening the glove box comes on the lamp.

When the glove box is not closed completely, the lamp may keep coming on.

## Mood Lamp

Dashboard mood lamp



Door mood lamp

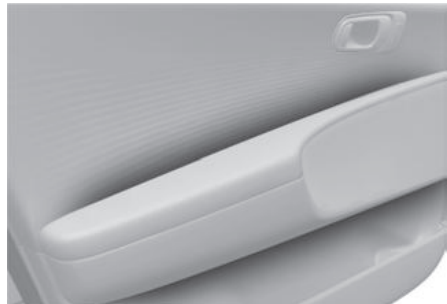

- To set the brightness and color of the mood lamp, select **Setup > Vehicle > Lights > Ambient Light** in the infotainment system.
- When driving at night or under low light driving conditions, the sensors detect the light level around the vehicle and automatically adjust the brightness of the mood light. To set the automatic brightness adjustment turn on/off, select **Setup > Vehicle > Lights > Ambient Light > Dimmed in Dark**.

- When you select **Setup > Vehicle > Lights > Ambient Light > Link to Drive Mode** in the infotainment system, the driver's and front passenger's mood lamps are set in color in conjunction with the drive mode. In the case of the rear seat, if the **'Link to Drive Mode'** function is selected while the speed-linked interior lighting is not selected, the rear seat mood lamp changes color in conjunction with the drive mode.
- When you select **Setup > Vehicle > Lights > Ambient Light > Link to Speed Alert** in the infotainment system, the driver's and front passenger's mood lamps change to red and blink when the vehicle speed exceeds the speed limit. In the case of the rear seat, when the **'Sync Lighting with Speed'** function is set, the mood lamp does not turn on even if the Link to Speed Alert function is set, but the mood lamp changes to red and blink when the vehicle speed exceeds the speed limit.
- When you select **Setup > Vehicle > Lights > Ambient Light > Sync Lighting with Speed** in the infotainment system, the brightness of the driver's and front passenger's mood lamps changes according to the speed. In the case of the rear seat, when the **'Sync Lighting with Speed'** function is selected, the mood lamp is turned on only in the 'P' (park). However, if the **'Link to Speed Alert'** function is selected, the rear seat mood lamp will also blink in red when the vehicle speed exceeds the speed limit.
- After selecting **Setup > Vehicle > Lights > Ambient Light > Link to Voice Recognition** in the infotainment system, when the voice recognition button on the steering wheel is pressed, the length of the dashboard's mood lamp lighting changes according to the volume of the user's voice and the pitch of the vehicle guidance voice.
- When the driver gets into the vehicle, the mood lamp on the dashboard turns on in sequence in conjunction with the welcome animation on the instrument panel. When getting off, the mood lamp on the dashboard turns off one after another in conjunction with the good-bye animation on the instrument panel.
- When the vehicle is drivable (the instrument panel **READY** indicator is on), the dashboard mood lamp turns on. However, the mood lamp does not turn on when using the utility mode.

### *i* Information

- The infotainment system may change after software updates. For more information, refer to the user's manual provided in the infotainment system and the quick reference guide.
- The color of the mood lamp may seem different under some conditions depending on the color of the interior and the set mood color.

### Front Trunk Lamp

The lamp illuminates when the hood opens. The lamp keeps coming on when the hood is not completely closed.



**NOTICE**

Make sure it is fully closed after closing the hood. If it is left open without starting vehicle, the lamp comes on and the battery may be discharged.

**Luggage Compartment Lamp**

The lamp turns on when the trunk is open.

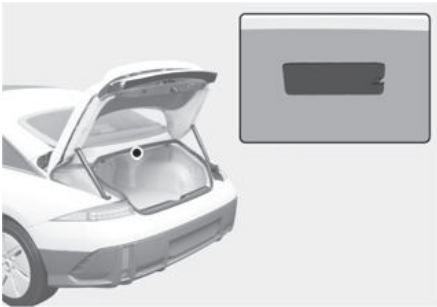

**NOTICE**

Make sure it is fully closed after closing the trunk. If it is left open without starting vehicle, the lamp comes on and the battery may be discharged.

**High Beam Assist (HBA)**

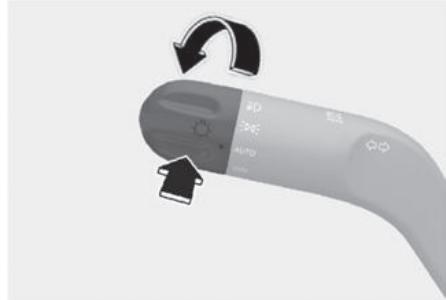

High Beam Assist automatically controls the headlights between high beam and low beam depending on the detected ambient light, such as an oncoming vehicle or leading vehicle.

**Detecting sensor**



(1) front view camera

The front view camera is used as a detecting sensor to detect ambient light and brightness while driving.

Refer to the illustration above for the detailed location of the detecting sensor.

**NOTICE**

- Always keep the front view camera in good condition to maintain optimal performance of High Beam Assist.
- For more information on the precautions of the front view camera, refer to the “Forward Collision-Avoidance Assist (FCA)” section in chapter 7.

## High Beam Assist Settings

### Setting features

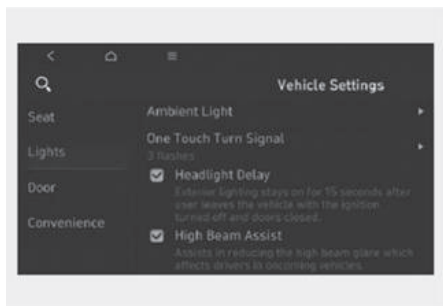

With the Start/Stop button in the ON position, select **Setup > Vehicle > High Beam Assist** from the Settings menu to turn on High Beam Assist and deselect to turn off the function.

**! WARNING**

For your safety, change the Settings after parking the vehicle at a safe location.

## High Beam Assist Operation

### Display and control

- After selecting '**High Beam Assist**' in the Settings menu, High Beam Assist will operate by following the procedure below.
  - Place the headlight switch in the AUTO position and push the headlight lever towards the instrument cluster. The High Beam Assist (HBA) indicator light will illuminate on the instrument cluster and High Beam Assist will be enabled.
  - When High Beam Assist is enabled, high beam will turn on when vehicle speed is above 25 mph (40 km/h). When vehicle speed is below 15 mph (25 km/h), high beam will turn off and the High Beam Assist (HBA) indicator will be displayed in white on the instrument cluster.
  - The High Beam (HBA) indicator light will illuminate on the instrument cluster when high beam is on.
- When High Beam Assist is operating, if the headlight lever or switch is used, High Beam Assist operates as follow:
  - If the headlight lever is pulled towards you when the high beam is off, the high beam will turn on without High Beam Assist canceled. When you let go of the headlight lever, the lever will move to the middle and the high beam will turn off.
  - If the headlight lever is pulled towards you when the high beam is on by High Beam Assist, low beam will turn on and the function will turn off.
  - If the headlight switch is placed from AUTO to another position (headlight/position/off), High Beam Assist will turn off and the corresponding light will turn on.

- When High Beam Assist is operating, high beam switches to low beam if any of the following conditions occur:
  - When the headlight of an oncoming vehicle is detected.
  - When the tail light of a vehicle in front is detected.
  - When the headlight or tail light of a motorcycle or a bicycle is detected.
  - When the surrounding ambient light is bright enough that high beams are not required.
  - When streetlights or other lights are detected.

### *i* Information

The images and colors in the instrument cluster may differ depending on the cluster type or theme selected from the settings menu.

---

## High Beam Assist Malfunction and Limitations

### **High Beam Assist malfunction**

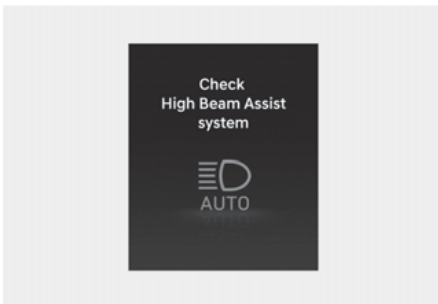

When High Beam Assist is not working properly, the '**Check High Beam Assist system**' warning message will appear and  warning light will illuminate on the instrument cluster. Have the function inspected by an authorized HYUNDAI dealer.

### **Limitations of High Beam Assist**

High Beam Assist may not work properly in the following situations:

- Light from an oncoming or front vehicle is not detected because of light damage, or because it is hidden from sight, etc.
- Headlight of an oncoming or front vehicle is covered with dust, snow or water.
- A front vehicle's headlights are off, but the fog lights are on, etc.
- There is a light that has a similar shape as a vehicle's light.
- Headlights have been damaged or not repaired properly.
- Headlights are not aimed properly.
- Driving on a narrow curved road, rough road, uphill or downhill.
- Vehicle in front is partially visible on a crossroad or curved road.
- There is a traffic light, reflecting sign, flashing sign or mirror ahead.
- There is a temporary reflector or flash ahead (construction area).
- The road conditions are bad such as being wet, iced or covered with snow.
- A vehicle suddenly appears from a curve.
- The vehicle is tilted from a flat tire or is being towed.
- Light from an oncoming or front vehicle is not detected due to obstacles in the air such as exhaust fume, smoke, fog, snow, or water spay or blizzard on the road, or fogging in the light, etc.

### *i* Information

For more information on the limitations of the Front View Camera, refer to the "Forward Collision-Avoidance Assist (FCA)" section in chapter 7.

---



## ⚠ WARNING

- At times, High Beam Assist may not work properly. High Beam Assist is for your convenience only. It is the responsibility of the driver for safe driving practices and always check the road conditions for your safety.
- When High Beam Assist does not operate properly, change the headlight position manually between high beam and low beam.
- When starting up or initializing the front camera (rebooting, etc.), the High Beam Assist function may not work for about 15 seconds.

## Wipers and Washers

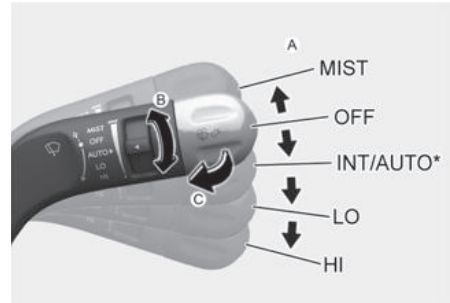

B5019601

### A. Wiper speed control

- MIST - Single wipe
- OFF - Off
- INT - Intermittent wipe  
AUTO\* - Auto control wipe
- LO - Low wiper speed
- HI - High wiper speed

### B. Intermittent wipe time adjustment/Auto control wipe time adjustment\*

### C. Wash with brief wipes

\*: if equipped

## Front Windshield Wipers

Operates as follows when the Start/Stop button is in the ON position.

### MIST:

For a single wiping cycle, push the lever upward (or downward) and release. The wipers will operate continuously if the lever is held in this position.

### OFF:

Wiper is not in operation.

### INT:

Wiper operates intermittently at the same wiping intervals. To vary the speed setting, turn the speed control knob (B).

### AUTO:

The rain sensor located on the upper end of the windshield glass senses the amount of rainfall and controls the wiping cycle for the proper interval. The more it rains, the faster the wiper operates. When the rain stops, the wiper stops. To vary the speed setting, turn the speed control knob.

### LO:

The wiper runs at a lower speed.

### HI:

The wiper runs at a higher speed.

## **i** Information

If there is heavy accumulation of snow or ice on the windshield, defrost the windshield for about 10 minutes, or until the snow and/or ice is removed before using the windshield wipers to ensure proper operation.

If you do not remove the snow and/or ice before using the wiper and washer, it may damage the wiper and washer system.

## **AUTO (Automatic) control**

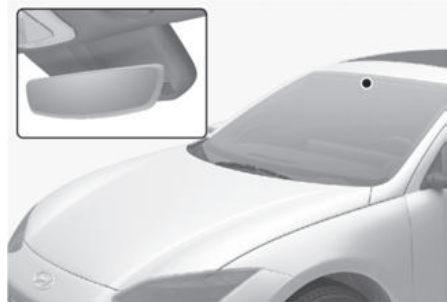

The rain sensor located on the upper end of the windshield glass senses the amount of rainfall and controls the wiping cycle for the proper interval.

The wiper operation time will be automatically controlled depends on rainfall.

When the rain stops, the wiper stops.

To vary the sensitivity setting, turn the sensitivity control knob.

If the wiper switch is set in AUTO mode when the Start/Stop button is in the ON position, the wiper will operate once to perform a self-check of the system. Set the wiper to the OFF position when the wiper is not in use.

## **⚠** WARNING

To avoid personal injury from the windshield wipers, when the vehicle is running and the windshield wiper switch is placed in the AUTO mode:

- Do not touch the upper end of the windshield glass facing the rain sensor.
- Do not wipe the upper end of the windshield glass with a damp or wet cloth.
- Do not put pressure on the windshield glass.

**NOTICE**

- When washing the vehicle, set the wiper switch in the OFF position to stop the auto wiper operation. The wiper may operate and be damaged if the switch is set in the AUTO mode while washing the vehicle.
- Do not remove the sensor cover located on the upper end of the passenger side windshield glass. Damage to system components could occur and may not be covered by your vehicle warranty.
- Because of using a photo sensor, temporary malfunction could occur according to sudden ambient light change made by stone and dust while driving.

**Front Windshield Washers**

In the OFF position, pull the lever gently toward you to spray washer fluid on the windshield and to run the wipers 1-3 cycles. The spray and wiper operation will continue until you release the lever. If the washer does not work, you may need to add washer fluid to the washer fluid reservoir.

**Recirculating air when washer fluid is used**

When washer fluid is used, in order to reduce any objectionable scent of the washer fluid from entering the cabin, recirculation mode and air conditioning are automatically activated depending on the outside temperature. If you select fresh mode while the function is operating, the function will resume after a certain amount of time. It may not work in some conditions such as cold weather or vehicle off.

For more information, refer to the “Climate Control Additional Features” section in this chapter.

**! WARNING**

When the outside temperature is below freezing, ALWAYS warm the windshield using the defroster to help prevent the washer fluid from freezing on the windshield and obscuring your vision which could result in an accident and serious injury or death.

**NOTICE**

- To prevent possible damage to the washer pump, do not operate the washer when the fluid reservoir is empty.
- To prevent possible damage to the wipers or windshield, do not operate the wipers when the windshield is dry.
- To prevent damage to the wiper arms and other components, do not attempt to move the wipers manually.
- To prevent possible damage to the wipers and washer system, use anti-freezing washer fluids in the winter season or cold weather.

## Automatic Climate Control System

Climate control panel

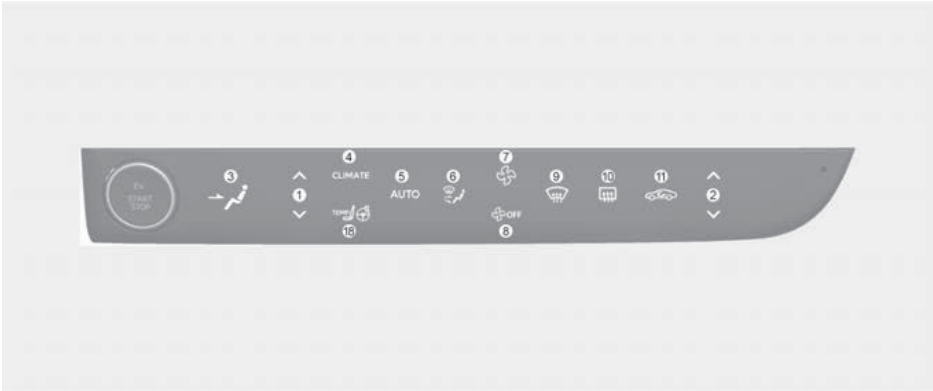

Infotainment System (Climate)



The actual shape for the climate control panel and infotainment system may differ from the illustration.

- (1) Driver's temperature control
- (2) Passenger's temperature control
- (3) Display the air flow direction
- (4) View climate infotainment system
- (5) AUTO (automatic control)
- (6) Mode selection button
- (7) Fan speed up
- (8) Fan speed down/OFF
- (9) Front windshield defroster
- (10) Rear windshield defroster
- (11) Air intake control
- (12) Driver only mode
- (13) A/C (air conditioning) ON/OFF

- (14) Heating ON/OFF
- (15) SYNC
- (16) Ambient temperature display
- (17) System OFF
- (18) Seat warmer/air ventilation infotainment system

### *i* Information

Use a clean soft microfiber cloth to gently wipe any finger prints off the touch screen.

---

## Climate

Climate control panel



Touch **'CLIMATE'** icon to view the climate information in the infotainment system.

Infotainment System

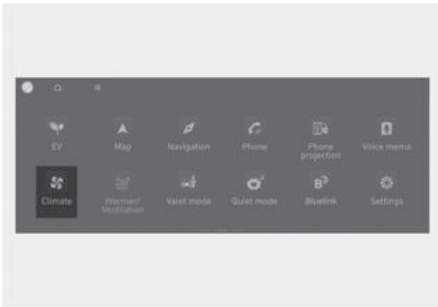

To view the climate information screen, select **'Climate'** in the main infotainment system when the vehicle is ON.

## Automatic Temperature Control Mode

1. Press **'AUTO'** icon or touch the **'AUTO'** icon in the infotainment system to select the fan speed (level 1-3).







Climate control panel



Infotainment system



2. Adjust the temperature with the temperature control icon.

Level	AUTO Indicator	Climate Information	Fan Speed Level
3		HIGH	1-8
			
2		MEDIUM	1-6
			
1		LOW	1-4
			

The fan speed level only can be changed manually.

The following systems can be respectively adjusted while the AUTO climate control is on. When those systems are adjusted, AUTO indicator lights will turn off.

- Fan speed level
- A/C (Air condition)
- Mode selection
- Front windshield defroster (When defroster is turned off, AUTO indicator light will illuminate)

For your convenience and to improve the efficiency of the climate control, use the AUTO button and set the temperature to 72 °F (22 °C).

To change the temperature unit from °C to °F or °F to °C:

Select **Setup > General > Unit > Temperature Unit > °C/°F** from the Settings menu in the infotainment system.

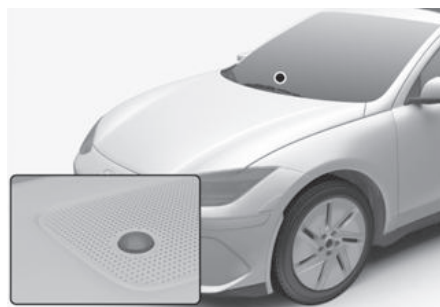



## Manual Temperature Control Mode

The heating and cooling system can be controlled manually by selecting functions other than 'AUTO'. In this case, the system works sequentially according to the order of the functions selected.

When selecting any other functions except 'AUTO' while using automatic operation, the functions not selected will be controlled automatically.

1. Start the vehicle.
2. Set the mode to the desired position.

To improve the effectiveness of heating and cooling, select the mode according to the following:

- Heating: 
- Cooling: 

3. Set the temperature control to the desired value.
4. Set the air intake control to Fresh or Recirculation mode.
5. Set the fan speed control to the desired speed.
6. If air conditioning is desired, turn the air conditioning system on.
7. Select 'AUTO' to revert back to full automatic control of the system.

**Mode selection**

Climate control panel



Infotainment system

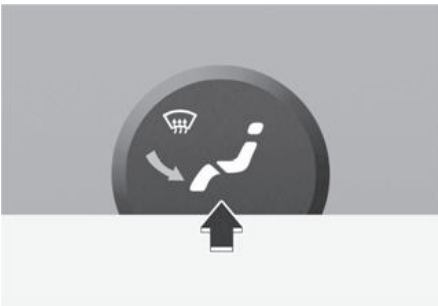

**Air flow direction**

Touch the air flow direction icon in the infotainment system to select the desired air flow direction. The selected air flow direction will be displayed on the infotainment system.



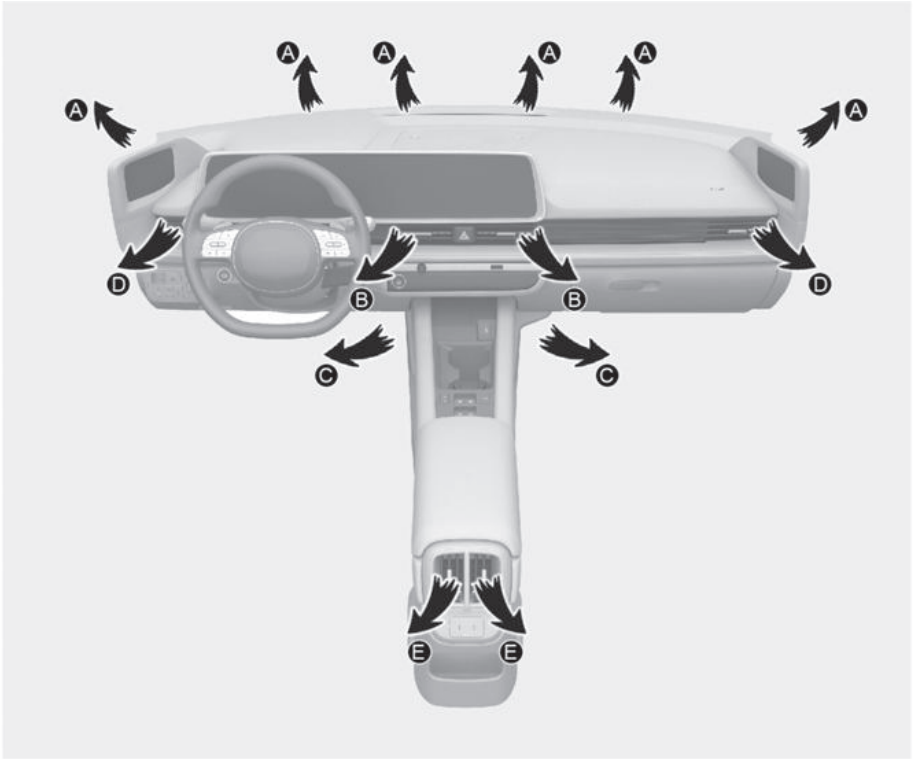

#### **Air flow direction**

The mode selection Icon or button controls the direction of the air flow through the ventilation system.

 **Face-Level (B, D)**

Air flow is directed toward the upper body and face. Additionally, each outlet can be controlled to direct the air discharged from the outlet.

 **Bi-Level (B, C, D, E)**

Air flow is directed towards the face and the floor.

 **All Level (A, B, C, D, E, F)**

Air flow is directed toward the face, the floor and the windshield.

 **Floor-Level (A, C, D, E)**

Most of the air flow is directed to the floor, with a small amount of the air being directed to the windshield and side window defrosters.

 **Floor/Defrost-Level (A, C, D, E)**

Most of the air flow is directed to the floor and the windshield with a small amount directed to the side window defrosters.

 **Defroster-Level (A, D)**

Most of the air flow is directed to the windshield with a small amount of air directed to the side window defrosters.

**Front windshield defroster**



**Defrost-level (A, D)**

Press the icon, and the indicator light will illuminate and the windshield defroster indicator will appear on the climate control panel.

Most of the air flow is directed to the windshield with a small amount of air directed to the side window defrosters.

When Defogging logic is enabled, Fresh mode is selected and air conditioning is selected according to outside temperature.

If the icon is pressed again, the indicator light will turn off and the previous settings will be selected.

## Instrument panel vents

Front seat

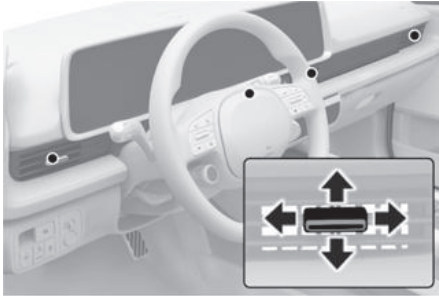

Rear seat

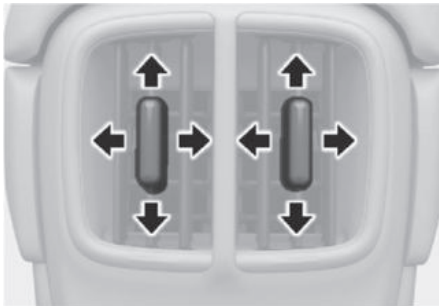

The instrument panel vent air flow can be directed up/down or left/right using the vent adjustment lever.

The air flow can also be CLOSED using the vent adjustment lever.

### Front seat

Move the lever away horizontally from the seat to close until the levers click and lock. Slightly move the lever toward the seating position to unlock and open.

### Rear seat

Move the lever downward to close the air flow. Move the lever upward to open the air flow.

## Temperature control

Climate control panel

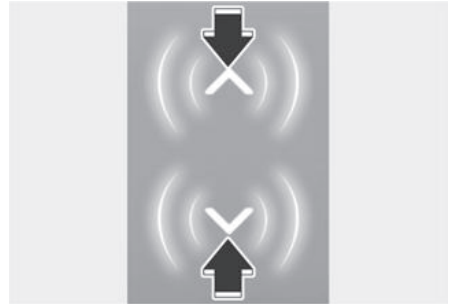

Infotainment system



Touch the  $\wedge$  or  $\vee$  icon to select the temperature.

The temperature can be increased or decreased by increments of 1 °F (0.5 °C) for each incremental location. When set to the lowest temperature setting, the air conditioning will operate continuously to quickly cool the interior of the vehicle initially. After interior temperature has been cooled down sufficiently, select '**AUTO**' and set the temperature to 72 °F (22 °C).

### **SYNC**



#### **Adjusting the temperature and air flow direction equally**

Press **'SYNC'** (indicator light ON), the passenger's temperature and air flow direction will be adjusted same as the driver's control.

#### **Adjusting the temperature and air flow direction individually**

Press **'SYNC'** (indicator light OFF), all seats temperature and air flow direction will be adjusted individually.

### **Air intake control**



Air intake control is used to select either Fresh mode (outside air) or Recirculation mode (cabin air).

#### **Recirculation mode**

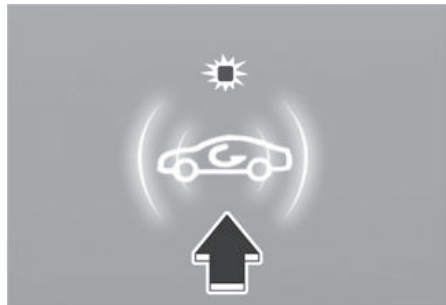

When Recirculation mode is selected, air from the passenger compartment will be recirculated through the system and heated or cooled according to the function selected.

### Fresh mode



When Fresh mode is selected, air enters the vehicle from outside and is heated or cooled according to the function selected.

### *i* Information

Operating the system primarily in Fresh mode is recommended. Use Recirculation mode temporarily only when needed. Prolonged operation of the heater in Recirculation mode and without the air conditioning ON can cause fogging of the windshield. In addition, prolonged use of the air conditioning ON in Recirculation mode may result in excessively dry, dehumidified air in the cabin and may promote formation of musty vent odor due to stagnant air.

### WARNING

- Continued use of the climate control system operation in Recirculation mode for a prolonged period of time may cause drowsiness to the occupants in the cabin. This may lead to loss of vehicle control which may lead to an accident.
- Continued use of the climate control system operation in Recirculation mode with the air conditioning OFF may allow humidity to increase inside the cabin. This may cause condensation to accumulate on the windshield and obscure visibility.

- Do not sleep in your vehicle or remain parked in your vehicle with the windows up and either the heater or the air conditioning ON for prolonged periods of time. Doing so may increase the levels of carbon dioxide in the cabin which may lead to serious injury or death.

### Fan speed control

Climate control panel



Infotainment system

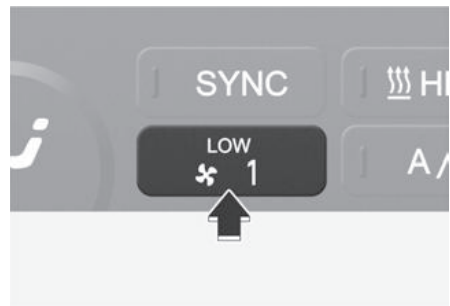

The fan speed can be set to the desired speed by adjusting the  icon in the climate control panel.

More air is delivered with higher fan speeds.

### **i** Information

To help improve microphone voice input sound, fan speed may automatically slow down for a couple of minutes when you activate voice recognition or hands free.

Pressing and holding the  icon turns off the fan.

### **NOTICE**

Operating the fan when the Start/Stop button is in the OFF position could cause the battery to discharge. Operate the fan when the vehicle is running.

### **Driver only**



If you touch the **'DRIVER ONLY'** icon  and the indicator light illuminates in the infotainment climate control screen, cold air mostly blows in the driver's seat. However, some of the cold air may come out of other seating position ducts to keep indoor air pleasant. If you use the icon with no passenger in the front passenger seat, energy consumption will be reduced.

**'DRIVER ONLY'** icon will be turned off under the following conditions:

1. Defrost on
2. DRIVER ONLY button re-touch

### **Air conditioning**

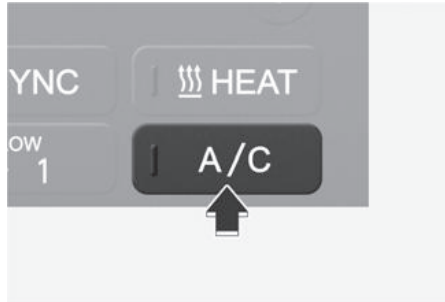

Touch the **'CLIMATE'** icon in the climate control screen. The climate information screen will appear on the infotainment system. Touch the A/C icon in the infotainment system to turn the air conditioning on (indicator light ON) and off.

### **HEAT icon**

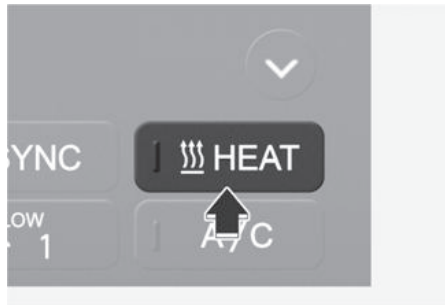

Touch **'CLIMATE'** icon in the climate control screen. The climate information screen will appear on the infotainment system. Touch the HEAT icon in the infotainment system to turn the heater on (indicator light will illuminate).

Touch the button again to turn the heater off.

The air conditioner and heater uses energy from the battery. If you use the heater or air conditioner for too long, distance to empty can be reduced due to too much power consumption.

Turn off the heater and air conditioner if you do not need them.

### OFF mode

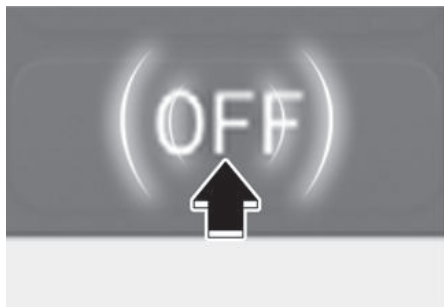

Touch the 'OFF' icon to turn the climate control system off.

## System Operation

### Cooling/Ventilation

1. Select the Face Level (👤) mode in the infotainment system.
2. Set the air intake control to fresh or recirculation mode.
3. Set the temperature to the desired position.
4. Set the fan speed to the desired speed.

### Heating

1. Select the Floor Level (👤) mode in the infotainment system.
2. Set the air intake control to fresh or recirculation mode.
3. Set the temperature to the desired position.
4. Set the fan speed to the desired speed.
5. If desired, turn the air conditioning ON with the temperature set high in order to dehumidify the air before it enters into the cabin.

If the windshield fogs up, select the Front Defrost (🌬️) mode.

### Operation Tips

- To keep dust or unpleasant fumes from entering the vehicle through the ventilation system, temporarily set the air intake control to the recirculation mode. Return the control to the Recirculation mode to the Fresh mode when the unpleasant air outside has diminished. This will help keep the driver alert and comfortable.
- To help prevent the inside of the windshield from fogging, set the air intake control to fresh mode and the fan speed to the desired position, turn on the air conditioning system, and adjust the temperature control to the desired temperature.

### Air conditioning

Your HYUNDAI Vehicle air conditioning system is filled with R-1234yf refrigerant.

1. Touch the **'CLIMATE'** icon to display climate information the infotainment system.
2. Select **'A/C'** icon (indicator light ON) in the climate information screen to activate the air-condition.
3. Set the temperature low.
4. Set the direction of air flow by touching the mode selection icon.
5. Touch the **'HEAT'** icon (indicator light OFF) to turn on the air-condition.

When maximum cooling is desired, set the temperature to the lowest position, then set the fan speed control to the highest setting.

#### Air conditioning system operation tips

- If the vehicle has been parked in direct sunlight during hot weather, open the windows for a short time to let the hot air inside the vehicle escape.
- After sufficient cooling has been achieved, switch back from recirculation mode to fresh mode.
- To help reduce moisture inside of the windows on rainy or humid days, decrease the humidity inside the vehicle by operating the air conditioning system with the windows and vision roof closed.
- Use the air conditioning system every month only for a few minutes to ensure maximum system performance.
- If you operate air conditioner excessively, the difference between the temperature of the outside air and that of the windshield could cause the outer surface of the windshield to fog up, causing loss of visibility. In this case, set the mode selection to the  position and fan speed control to the lowest speed.

## System Maintenance

### Cabin air filter

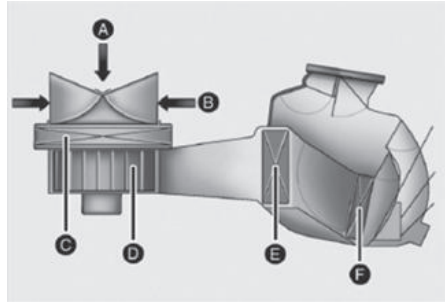

- [A] Outside air
- [B] Recirculated air
- [C] Cabin air filter
- [D] Blower
- [E] Evaporator core
- [F] PTC & Inner condenser

The cabin air filter is installed behind the front trunk. It filters the dust or other pollutants that enter the vehicle through the heating and air conditioning system.

Have the cabin air filter replaced by an authorized HYUNDAI dealer according to the maintenance schedule. If the vehicle is being driven in severe conditions such as dusty or rough roads, more frequent cabin air filter inspections and changes are required.

If the air flow rate suddenly decreases, have the system inspected at an authorized HYUNDAI dealer.



### **Checking the amount of air conditioner refrigerant and compressor lubricant**

When the amount of refrigerant is low, the performance of the air conditioning is reduced. Overfilling also reduces the performance of the air conditioning system.

Therefore, if abnormal operation is found, have the system inspected by an authorized HYUNDAI dealer.

#### **NOTICE**

It is important that the correct type and amount of oil and refrigerant is used. Otherwise, damage to the compressor and abnormal system operation may occur. To prevent damage, the air conditioning system in your vehicle should only be serviced by trained and certified technicians.

#### **NOTICE**

The refrigerant system should only be serviced by trained and certified technicians to insure proper and safe operation.

The refrigerant system should be serviced in a well-ventilated place.

The air conditioning evaporator (cooling coil) shall never be repaired or replaced with one removed from a used or salvaged vehicle and new replacement MAC evaporators shall be certified (and labeled) as meeting SAE Standard J2842.

#### **⚠ WARNING**

Vehicles equipped with R-1234yf



Since the refrigerant is mildly flammable and operated at high pressure, the air conditioning system should only be serviced by trained and certified technicians. It is important that the correct type and amount of oil and refrigerant are used.

All refrigerants should be reclaimed with proper equipment.

Venting refrigerants directly to the atmosphere is harmful to individuals and environment. Failure to heed these warnings can lead to serious injuries.



### Air Conditioning refrigerant label

You can find out which air conditioning refrigerant is applied to your vehicle on the label located in the left side of the cowl cover.

Example

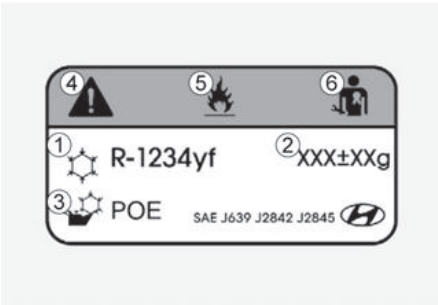



Each symbol and specification on the air conditioning refrigerant label is represented as below:

1. Classification of refrigerant
2. Amount of refrigerant
3. Classification of compressor lubricant
4. Caution
5. Flammable refrigerant
6. To require registered technician to service air conditioning system

## Windshield Defrosting and Defogging

### WARNING

#### Windshield heating

Do not use the  position during cooling operation in extremely humid weather. The difference between the temperature of the outside air and that of the windshield could cause the outer surface of the windshield to fog up, causing loss of visibility could cause an accident resulting in serious injury or death. In this case, set the mode selection to the  position and fan speed control to a lower speed.

- For maximum defrost performance, set the temperature control to the highest temperature setting and the fan speed control to the highest setting.
- If warm air to the floor is desired while defrosting or defogging, set the mode to the floor-defrost position.
- Before driving, clear all snow and ice from the windshield, rear window, side view mirrors, and all side windows.
- Clear all snow and ice from the hood and air inlet in the cowl grill to improve heater and defroster efficiency and to reduce the probability of fogging up the inside of the windshield.

## To Defog Inside Windshield

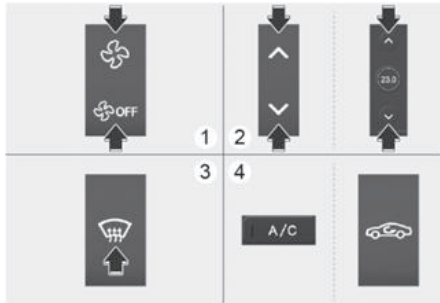

1. Select the desired fan speed.
2. Select the desired temperature.
3. Touch the defroster icon (☸).
4. When the defogging logic is enabled, Fresh mode is selected and air conditioning is selected according to outside temperature.

Check to make sure the air intake control is in Fresh mode. If the air intake control indicator light is illuminated, touch the icon once to enable Fresh mode (indicator light OFF).

If the ☸ position is selected, the fan speed is automatically increased.

## To Defrost Outside Windshield

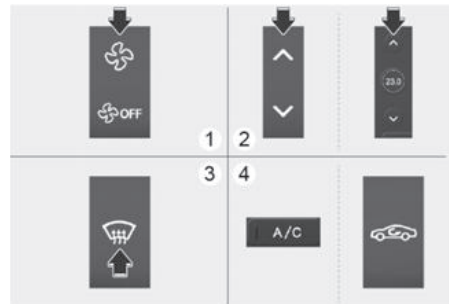



1. Set the fan speed to the highest position.
2. Set the temperature to the extreme hot position.
3. Touch the defroster icon (☸).
4. When Defogging logic is enabled, Fresh mode is selected and air conditioning is selected according to outside temperature.

Check to make sure the air intake control is in Fresh mode. If the air intake control indicator light is illuminated, touch the icon once to enable Fresh mode (indicator light OFF).

If the ☸ position is selected, lower fan speed is adjusted to a higher fan speed.

## Defogging Logic

To reduce the probability of fogging up the inside of the windshield, the air intake or air conditioning are controlled automatically according to certain conditions such as  positions. To cancel or reset the defogging logic, do the following.

1. Press the Start/Stop button to the ON position.
2. Touch the defroster icon () or ()
3. While touching the A/C icon, touch the air intake control icon at least 5 times within 3 seconds.

The air intake control indicator will blink 3 times to indicate that the defogging logic has been disabled. Repeat the steps again to re-enable the defogging logic.

The air intake control indicator will blink 6 times to indicate that the defogging logic has been enabled.

If the battery has been discharged or disconnected, it resets to the defog logic status.

## Rear Window Defroster

### NOTICE

To prevent damage to the rear window defroster conducting elements bonded to the inside surface of the rear window, never use sharp instruments or window cleaners containing abrasives to clean the window.

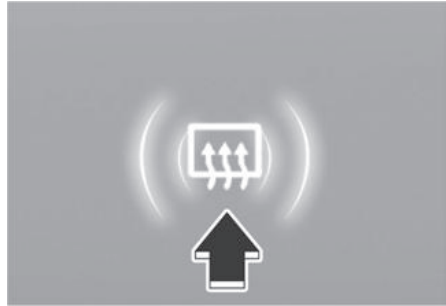

The defroster heats the window to remove frost, fog and thin ice from the interior and exterior of the rear window, while the vehicle is running.

- To activate the rear window defroster, touch the rear window icon located in the center control panel. The indicator on the rear window defroster illuminates when the defroster is on.
- To turn off the defroster, touch the rear window defroster button again.

### Information

- If there is heavy accumulation of snow on the rear window, brush it off before operating the rear defroster.
- The rear window defroster automatically turns off after about 20 minutes or when the Start/Stop button is in the OFF position.

### **Side view mirror defroster**

If your vehicle is equipped with the rearview mirror defrosters, they will operate at the same time you turn on the rear window defroster.

## Climate Control Additional Features

### A/C Automatic Drying

A/C Automatic Drying feature dries the moisture in the air conditioner and reduces air conditioner odor. The blower motor automatically operates after 30 minutes the vehicle is turned off.

#### **Turning A/C Automatic Drying On or off**

The A/C Automatic Drying feature can be turned on and off by selecting **Setup > Vehicle Settings > Climate > Climate Features > A/C Automatic Drying** from the infotainment system.

#### **i Information**

The infotainment system may change after software updates. For more information, refer to the user's manual provided in the infotainment system and the quick reference guide.

If the operating condition is satisfied after setting the feature, the operating condition is displayed on the infotainment system and the blower motor automatically operates.

When the A/C Automatic Drying feature is activated, the air conditioner sets the fan speed to the third level, selects Fresh mode, and directs the air flow to the floor.

#### **Operating conditions**

The A/C Automatic Drying feature operates under the following conditions:

- The vehicle is turned off after operating the air conditioner for a certain period
- The 12 V battery level is sufficient
- The outside temperature is above a certain level

#### **Non-operating conditions**

The A/C Automatic Drying feature stops operating under the following conditions:

- The A/C Automatic Drying feature has operated for 3 minutes
- The Start/Stop button is pressed, or the vehicle is on
- The climate control system is operated remotely

#### **i Information**

- The A/C Automatic Drying feature reduces air conditioner odors but may not remove all odors.
- The A/C Automatic Drying feature does not operate if the remaining battery level is insufficient to prevent battery discharge.

## Auto Defogging System



Auto defogging helps reduce the possibility of fogging up the inside of the windshield by automatically sensing the moisture on inside the windshield.

#### **i Information**

The auto defogging system may not operate normally, when the outside temperature is below 14 °F (-10 °C).



When the Auto Defogging System operates, the indicator will illuminate.

If a high amount of humidity is detected in the vehicle, the Auto Defogging System will be enabled. The following steps will be performed automatically:

Step 1)

Air conditioning will turn ON.

Step 2)

Air intake control will change to Fresh mode.

Step 3)

Mode will change to defrost to direct airflow to the windshield.

Step 4)

Fan speed will be set to MAX.

If the air conditioning is off or recirculation mode is manually selected while Auto Defogging System is ON, the Auto Defogging System indicator will blink 3 times to signal that the manual operation has been canceled.

### **Turning the Auto Defogging System ON or OFF**

#### **Climate control system**

Touch the front windshield defroster icon for 3 seconds when the Start/Stop button is in the ON position. When the Auto Defogging System is turned off, the ADS OFF symbol will blink 3 times and ADS OFF will be displayed on the climate control information system.

When the Auto Defogging System is turned on, the ADS OFF symbol will blink 6 times without a signal.

#### **Infotainment system**

Auto Defogging System can be turned on and off by selecting **Setup > Vehicle > Climate > Defog/Defrost Options > Auto Defog** from the infotainment system.

#### ***i* Information**

The infotainment system may change after software updates. For more information, refer to the user's manual provided in the infotainment system and the quick reference guide.

---

#### ***i* Information**

- When the air conditioning is turned on by Auto Defogging System, if you try to turn off the air conditioning, the indicator will blink 3 times and the air conditioning will not be turned off.
  - To maintain the effectiveness and efficiency of the Auto Defogging System, do not select Recirculation mode while the system is operating.
  - When Auto Defogging System is operating, fan speed adjustment, temperature adjustment, and air intake control selection are all disabled.
- 

#### **NOTICE**

Do not remove the sensor cover located on the upper end of the windshield glass. Damage to system parts could occur and may not be covered by your vehicle warranty.

---

## Auto Dehumidify

 if equipped

To increase cabin air quality and reduce windshield misting, recirculation mode switches off automatically after about 5 minutes, depending on the outside temperature, and the air intake will change to fresh mode.

### **Turning Auto Dehumidify ON or OFF**

#### Climate control system

To turn the Auto Dehumidify feature on or off, select Face level (↔) mode and touch the air intake control icon  at least five times within three seconds. When Auto Dehumidify is turned on, the air intake control button indicator will blink 6 times. When turned off, the indicator will blink 3 times.

#### Infotainment system

Auto Dehumidify can be turned on and off by selecting **Setup > Vehicle > Climate > Automatic Ventilation > Auto Dehumidify** from the infotainment system.

### Information

If the battery (12 V) is discharged or disconnected, Auto dehumidify settings will be reset. Readjust the settings to turning Auto dehumidify option ON or OFF.

### **NOTICE**

The infotainment system may change after software updates. For more information, refer to the user's manual provided in the infotainment system and the quick reference guide.

## Sunroof Inside Air recirculation

 if equipped

When the is sunroof opened, fresh mode will be automatically selected. At this time, if you press the air intake control button, recirculation mode will be selected but will change back to fresh mode after 3 minutes. When the sunroof is closed, the air intake position will return to the original position that was selected.

## Recirculating Air When Washer Fluid Is Used

Recirculation mode automatically activates to reduce any objectionable scent of the washer fluid from entering the cabin when the windshield washer is used.

### **Turning Activate upon Washer Fluid Use ON or OFF**

Activate upon Washer Fluid Use can be turned on and off by selecting **Setup > Vehicle > Climate > Internal air circulation > Activation on washer fluid use** from the infotainment system.

### Information

The infotainment system may change after software updates. For more information, refer to the user's manual provided in the infotainment system and the quick reference guide.

## Recirculating air when entering a tunnel

 If equipped

To prevent the inflow of polluted air into the vehicle when passing through a tunnel, the windows and climate control system are operated using the navigation map information and vehicle speed as follows:

To use this feature, it can be enabled from the infotainment system. Select:

### Vehicle > Climate > Recirculate Air

- Tunnel section: The vehicle's windows automatically close, and the climate control system switches to recirculation mode for about 7 seconds before entering a tunnel.

The windows open to the previous position after passing through the tunnel. If the power window switch is operated before the windows open, the windows do not return to the previous position.

## Operating conditions

- The climate control system's fresh mode is selected.
- The window(s) are open. The windows close automatically only when your vehicle is applied with the automatic up/down window feature for all seats.

### Information

- The activation time for the feature may differ because of the time gap between the GPS and vehicle speed.
- The feature activates until you have passed through continuous tunnels.
- When entering a tunnel, recirculation mode may cause fogging of the windshield. Use the front windshield defroster button.
- The feature does not operate in short tunnels.
- The feature may not activate if the GPS is not working properly.
- The infotainment system may change after software updates. For more information, refer to the user's manual provided in the infotainment system and the quick reference guide.

---

### WARNING

Be careful not to get any body parts caught when the windows are closing.

---



## Automatic Controls Linked to Climate Control Settings (for driver's seat)

The temperature of the driver's seat warmer, air ventilated seat and heated steering wheel is automatically controlled depending on the inside and outside temperature of the vehicle when the vehicle is running.

To use these features, it must be enabled from the Settings menu in the infotainment system.

Select **Setup > Vehicle > Seat > Warmer/Ventilation Features > Link to Climate Settings for Auto-Adjustment > Driver Seat Warmer/Ventilation.**

For more information on Auto Comfort Control, refer to the "Seat Warmers" and "Air Ventilation Seats" section in chapter 3 and "Heated Steering Wheel" section in this chapter.

## Smart Ventilation

The smart ventilation system maintains pleasant/fresh air condition inside the passenger compartment by automatically detecting/controlling the temperature and humidity, when you drive the vehicle with the climate control system in the OFF position. When the smart ventilation system starts to operate, the message **'SMART VENTILATION ON'** appears for 5 seconds.

- The smart ventilation system stops operating, when the BLOWER DOWN OFF button of the climate control system is selected.
- The smart ventilation system stops operating, when any button of the climate control system is selected for operation.
- The smart ventilation system may not operate, when the vehicle is driven at low speed.

## Storage Compartment

### WARNING

Never store cigarette lighters, propane cylinders, or other flammable/explosive materials in the vehicle. These items may catch fire and/or explode if the vehicle is exposed to hot temperatures for extended periods.

### WARNING

ALWAYS keep the storage compartment covers closed securely while driving. Items inside your vehicle are moving as fast as the vehicle. If you have to stop or turn quickly, or if there is a crash, the items may fly out of the compartment and may cause an injury if they strike the driver or a passenger.

### NOTICE

To avoid possible theft, do not leave valuables in the storage compartments.

## Center Console Storage

### Console Box



To open:

Grab and hold the latch on the arm rest then lift the lid.

- This space provides objects storing compartment.

### Glove Box

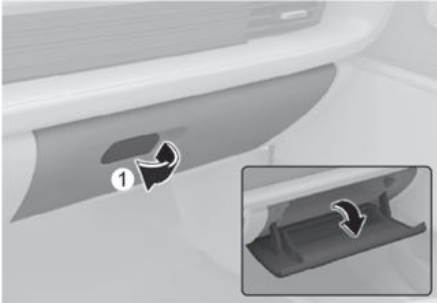

To open:  
Pull the lever (1).

#### **WARNING**

ALWAYS close the glove box door after use.

An open glove box door can cause serious injury to the passenger in an accident, even if the passenger is wearing a seat belt.

#### **NOTICE**

Use of excessive force to the glove box may damage the sliding rail or the lever.

## Interior Features

### Cup Holder

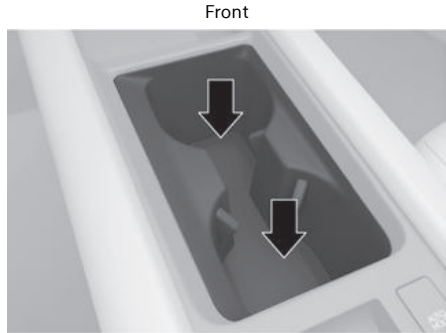

Front



Rear

Cups or small beverages cups may be placed in the cup holders.

**⚠ WARNING**

- Avoid abrupt starting and braking when the cup holder is in use to prevent spilling your drink. If hot liquid spills, you could be burned. Such a burn to the driver could cause loss of vehicle control resulting in an accident.
- Do not place uncovered or unsecured cups, bottles, cans, etc., in the cup holder containing hot liquid while the vehicle is in motion. Injuries may result in the event of a sudden stop or collision.
- Only use soft cups in the cup holders. Hard objects can injure you in an accident.

**⚠ WARNING**

Keep cans or bottles out of direct sun light and do not put them in a hot vehicle. It may explode.

**NOTICE**

- Keep your drinks sealed while driving to prevent spilling your drink. If liquid spills, it may get into the vehicle's electrical/electronic system and damage electrical/electronic parts.
- When cleaning spilled liquids do not use hot air to blow out or dry the cup holder. This may damage the interior.

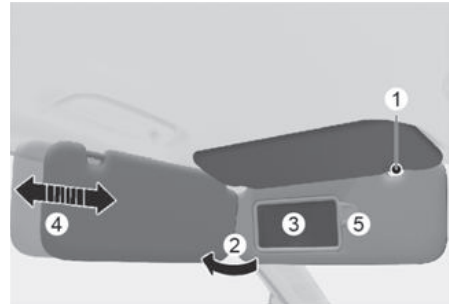
**Sunvisor**

To use the sunvisor, pull it downward.

To use the sunvisor to block the sun from the side window, pull it downward, release it from the bracket (1) and swing it to the side (2) towards the window.

To use the vanity mirror, pull down the sunvisor and slide the mirror cover (3).

Adjust the sunvisor forward or backward (4) as needed (if equipped). Use the ticket holder (5) to hold tickets.

Close the vanity mirror cover securely and return the sunvisor to its original position after use.

**⚠ WARNING**

For your safety, do not block your view when using the sunvisor.

**NOTICE**

- The tab (5) adjacent to the vanity mirror on the sunvisor can be used for toll road tickets or self parking tickets. Use caution when inserting tickets into the ticket holder to avoid damage. Refrain from putting several tickets in the ticket holder as this could also damage the retaining tab.
- Always have the switch in the off position when the vanity mirror light is not in use. If the sunvisor is closed without the light off, it may discharge the battery or damage the sunvisor.

## Power Outlet

Front



The power outlet is designed to provide power for mobile telephones or other devices designed to operate with vehicle electrical systems. The devices should draw less than 180 W with the vehicle on (READY indicator on).

### WARNING

Avoid electrical shocks. Do not place your fingers or foreign objects (pin, etc.) into a power outlet or touch the power outlet with a wet hand.

### NOTICE

To prevent damage to the power outlets:

- Use the power outlet only when the vehicle is running and remove the accessory plug after use. Using the accessory plug for prolonged periods of time with the vehicle off could cause the battery to discharge.
- Only use 12 V electric accessories which are less than 180 W in electric capacity.
- Adjust the air-conditioner or heater to the lowest operating level when using the power outlet.
- Close the cover when not in use.

- Some electronic devices can cause electronic interference when plugged into a vehicle's power outlet. These devices may cause excessive audio static and malfunctions in other electronic systems or devices used in your vehicle.
- Push the plug in as far as it will go. If good contact is not made, the plug may overheat and the fuse may open.
- Plug in battery equipped electrical/electronic devices with reverse current protection. The current from the battery may flow into the vehicle's electrical/electronic system and cause system malfunction.

## USB Charger

 If equipped

Front



Rear



The USB charger is designed to recharge batteries of small size electrical devices using a USB cable.

The electrical devices can be recharged when the Start/Stop button is in the ON or START position.

The battery charging state may be monitored on the electrical device.

Disconnect the USB cable from the USB port after use.

- A smartphone or a tablet PC may get warmer during the recharging process. It does not indicate any malfunction with the charging system.
- A smartphone or a tablet PC, which adopts a different recharging method, may not be properly recharged. In this case, use an exclusive charger of your device.
- The charging terminal is only to recharge a device. Do not use the charging terminal either to turn ON an audio or to play media in the infotainment system.

### NOTICE

- Use the USB charger when the vehicle on (READY indicator on). Using the USB charger for prolonged periods of time with the vehicle off could cause the battery to discharge.
- To prevent damage to the USB charger:
  - Do not insert foreign objects or spill liquid into the outlet. The USB charging terminal may be damaged.
  - Do not use devices with current consumption exceeding 2,100 mA (2.1 A).

## Wireless Smartphone Charging System

 if equipped

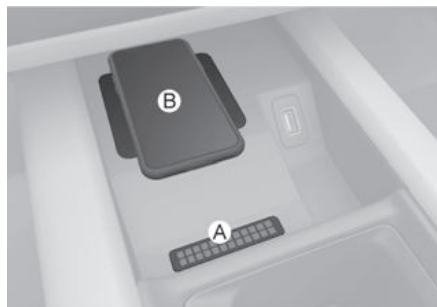

[A] Indicator light  
[B] Charging pad

On certain models, the vehicle comes equipped with a wireless smartphone charger.

The system is available when all doors are closed, and when the Start/Stop button is in the ON or START position.

### Charging smartphone

The wireless smartphone charging system charges only the Qi-enabled smartphones (☑). Read the label on the smartphone accessory cover or visit your smartphone manufacturer's website to check whether your smartphone supports the Qi technology.

The wireless charging process starts when you put a Qi-enabled smartphone on the wireless charging unit.

1. Remove other items, including the smart key, from the wireless charging unit. If not, the wireless charging process may be interrupted. Place the smartphone on the center of the charging pad.
2. The indicator light is orange when the smartphone is charging. The indicator light will turn green when phone charging is complete.

3. You can turn ON or OFF the wireless charging function from the Settings menu in the infotainment system. Select **Setup > Vehicle > Convenience > Wireless Charging System for Mobile Devices**

### **i** Information

- The infotainment system may change after software updates. For more information, refer to the user's manual provided in the infotainment system and the quick reference guide.
- For flip type smartphones, when using wireless charging, place the smartphone folded with the device's back placed on the center of the wireless charging unit.

If your smartphone is not charging:

- Slightly change the position of the smartphone on the charging pad.
- Make sure the indicator light is orange.

The indicator light will blink orange for 10 seconds if there is a malfunction in the wireless charging system.

In this case, temporarily stop the charging process, and re-attempt to charge your smartphone again.

The system warns you with a message on the cluster display if the smartphone is still on the wireless charging unit after the vehicle is turned OFF and the front door is opened.

For some manufacturer's smartphones, the system may not warn you even though the smartphone is left on the wireless charging unit. This is due to the particular characteristic of the smartphone and not a malfunction of the wireless charging.

### **NOTICE**

- Smartphones that do not have wireless charging standard (Ⓢ) certification, such as iPhones, may not charge normally.
- When placing your smartphone on the charging pad, position the phone in the middle of the mat for optimal charging performance. If your smartphone is off to the side, the charging rate may be less and in some cases the smartphone may experience higher heat conduction.
- In some cases, the wireless charging may stop temporarily when the smart key is used, either when starting the vehicle or locking/unlocking the doors, etc.
- When charging certain smartphones, the charging indicator may not change to blue when the smartphone is fully charged.
- The wireless charging process may temporarily stop, when temperature abnormally increases inside the wireless smartphone charging system. The wireless charging process restarts, when temperature falls to a certain level.
- The wireless charging process may temporarily stop when there is any metallic item, such as a coin, between the wireless smartphone charging system and smartphone.
- When charging some smartphones with a self-protection feature, the wireless charging speed may decrease and the wireless charging may stop.
- If the smartphone has a thick cover, the wireless charging may not be possible.
- If the smartphone is not completely contacting the charging pad, wireless charging may not operate properly.

- Some magnetic items like credit cards, phone cards or rail tickets may be damaged if left with the smartphone during the charging process.
- When any smartphone without a wireless charging function or a metallic object is placed on the charging pad, a small noise may sound. This small sound is due to the vehicle discerning compatibility of the object placed on the charging pad. It does not affect your vehicle or the smartphone in any way.

### **i** Information

If the Start/Stop button is in the OFF position, the charging also stops.

### **i** Information

This device complies with Part 15 of the FCC rules.

Operation is subject to the following three conditions:

1. This device may not cause harmful interference.
2. This device must accept any interference received, including interference that may cause undesired operation.
3. Changes or modifications not expressly approved by the party responsible for compliance could void the user's authority to operate the device

## Vehicle to Load (V2L)

**+** if equipped



V2L(Vehicle to Load) is installed at the central rear seat. V2L is a convenient feature which provides enough electricity to use diverse household electrical appliances in the vehicle.

V2L is installed at the central rear seat bottom.

For more information, refer to the "Using V2L Function" section in chapter 1.

## Clock

The clock can be set from the infotainment system.

For more information, refer to the user's manual provided in the infotainment system and the quick reference guide.

### **!** WARNING

Do not attempt to adjust the clock while driving. Doing so may result in distracted driving which may lead to an accident involving personal injury or death.

## Coat Hook

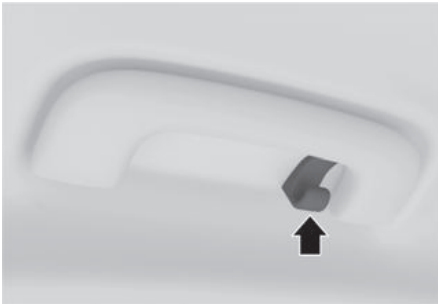

These hooks are not designed to hold large or heavy items.

### WARNING

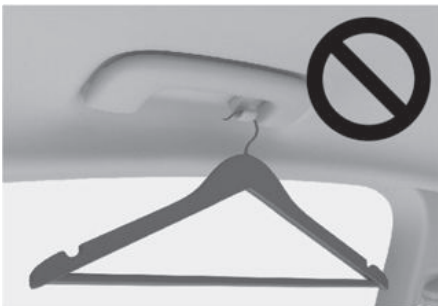

Do not hang other objects such as hangers or hard objects except clothes. Also, do not put heavy, sharp or breakable objects in the clothes pockets. In an accident or when the curtain airbag is inflated, it may cause vehicle damage or personal injury.

## Floor Mat Anchor(s)

ALWAYS use the Floor Mat Anchors to attach the front floor mats to the vehicle. The anchors on the front floor carpet keep the floor mats from sliding forward.

### WARNING

Do not overlay additional mats or liners over the floor mats. If using All Weather mats, remove the carpeted floor mats before installing them. Only use floor mats designed to connect to the anchors.

### WARNING

The following must be observed when installing ANY floor mat to the vehicle.

- Ensure to remove a protective film attached on the carpet before attaching a floor mat on the front floor carpet. Otherwise, the floor mat may move freely on the protective film and it could result in unintentional braking or accelerating.
- Ensure that the floor mats are securely attached to the vehicle's floor mat anchor(s) before driving the vehicle.
- Do not use ANY floor mat that cannot be firmly attached to the vehicle's floor mat anchors.
- Do not stack floor mats on top of one another (for example, all-weather rubber mat on top of a carpeted floor mat). Only a single floor mat should be installed in each position.

**IMPORTANT** Your vehicle was manufactured with driver's side floor mat anchors that are designed to securely hold the floor mat in place. To avoid any interference with pedal operation, HYUNDAI Vehicle recommends that the HYUNDAI floor mat designed for use in your vehicle be installed.



## Infotainment System

### NOTICE

- If you install an aftermarket HID head light, your vehicle's audio and electronic devices may not function properly.
- Prevent chemicals such as perfume, cosmetic oil, sun cream, hand cleaner, and air freshener from contacting the interior parts because they may cause damage or discoloration.

## USB Port



You can use a USB cable to connect audio devices to the vehicle USB port.

### *i* Information

When using a portable audio device connected to the power outlet, noise may occur during playback. If this happens, use the portable audio device's power source.

## Antenna

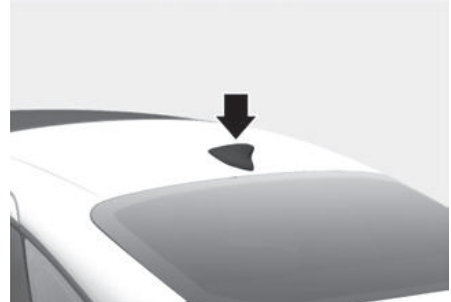

The shark fin antenna will receive AM, FM broadcast signals and transmit data.

## Steering Wheel Remote Controls

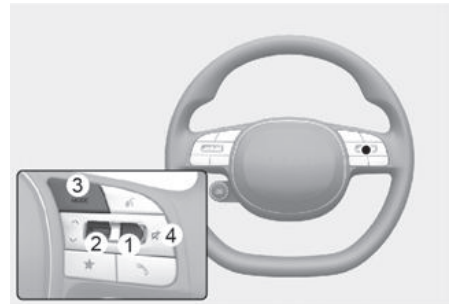

### NOTICE

Do not operate multiple audio remote control buttons simultaneously.

### **VOLUME (VOL + / VOL -) (1)**

- Rotate the VOLUME scroll up to increase volume.
- Rotate the VOLUME scroll down to decrease volume.

#### ***i* Information**

You can set the volume level of each source (FM, AM, SXM, USB, BT, etc.) individually by adjusting the VOLUME scroll.

Then the infotainment system saves the last volume level of each source in the system sound settings.

If you change the source, the volume will revert to the previously set volume for that source.

---

### **SEEK/PRESET (^ / v) (2)**

If the SEEK/PRESET switch is pressed up or down and held for 0.8 second or more, it will function in the following modes:

#### **RADIO mode**

It will function as the AUTO SEEK select button. It will SEEK until you release the button.

#### **MEDIA mode**

It will function as the FF/RW button.

If the SEEK/PRESET switch is pressed up or down, it will function in the following modes:

#### **RADIO mode**

It will function as the PRESET STATION UP/DOWN button.

#### **MEDIA mode**

It will function as the TRACK UP/ DOWN button.

### **MODE (3)**

Press the MODE button to toggle through Radio or AUX modes.

### **MUTE (M) (4)**

Press and hold the volume button to mute or activate the sound.

#### ***i* Information**

The infotainment system may change after software updates. For more information, refer to the user's manual provided in the infotainment system and the quick reference guide.

---

## Infotainment System



#### ***i* Information**

The infotainment system may change after software updates. For more information, refer to the user's manual provided in the infotainment system and the quick reference guide.

---

## Voice Recognition

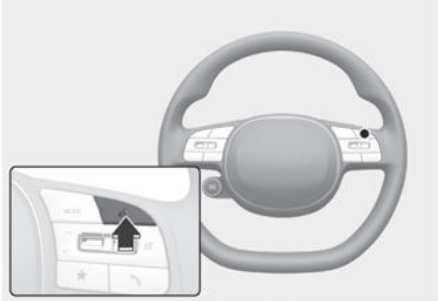

### *i* Information

The infotainment system may change after software updates. For more information, refer to the user's manual provided in the infotainment system and the quick reference guide.

## Bluetooth® Wireless Technology

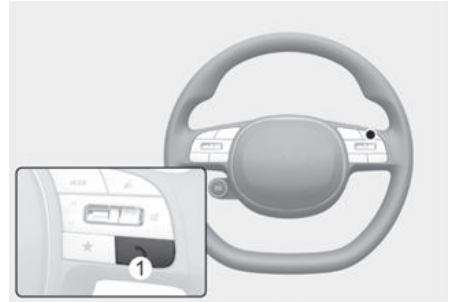

- (1) Call / Answer / Call end button
- (2) Microphone

### *i* Information

The infotainment system may change after software updates. For more information, refer to the user's manual provided in the infotainment system and the quick reference guide.

### CAUTION

To avoid driver distractions, do not excessively operate the device while driving the vehicle which may lead to an accident.



# 6. Driving Your Vehicle

Before Driving .....	6-3
Before Entering the Vehicle .....	6-3
Before Starting .....	6-3
Start/Stop Button .....	6-4
Start/Stop Button Positions .....	6-5
Starting the Vehicle .....	6-6
Turning Off the Vehicle.....	6-7
Remote Start .....	6-7
Shift By Wire.....	6-8
Shift By Wire Operation .....	6-8
Cluster Display Messages Information.....	6-12
Good Driving Practices.....	6-13
Regenerative Braking System (Paddle Shifter) .....	6-14
Using Regenerative Braking System .....	6-14
Regenerative Braking System Limitations .....	6-15
One Pedal Driving .....	6-15
Using i-PEDAL .....	6-16
Smart Regeneration System .....	6-17
Smart Regeneration System On/Off.....	6-17
Smart Regeneration System Operating Condition.....	6-18
Smart Regeneration Level Settings .....	6-18
Pausing Smart Regeneration System .....	6-19
Front Sensors .....	6-19
System Check Message.....	6-20
Smart Regeneration System Precautions .....	6-20
Braking System .....	6-23
Power-Assist Brakes .....	6-23
Disc Brakes Wear Indicator .....	6-24
Electronic Parking Brake (EPB) .....	6-24
Auto Hold.....	6-28
Brake Disc Cleaning.....	6-30
Anti-Lock Brake System (ABS).....	6-30
Electronic Stability Control (ESC).....	6-32
Vehicle Stability Management (VSM).....	6-34
Hill-Start Assist Control (HAC) .....	6-35
Brake Assistant System (BAS).....	6-35

Good Braking Practices.....	6-36
All Wheel Drive (AWD) .....	6-37
Emergency Precautions.....	6-39
Drive Mode Integrated Control System (2WD).....	6-40
Drive Mode.....	6-40
Drive mode Integrated Control System (AWD) .....	6-42
Drive Mode.....	6-42
Drive Modes Characteristic .....	6-44
Active Air Flap.....	6-45
Malfunction.....	6-45
Active sound design.....	6-45
Special Driving Conditions .....	6-46
Hazardous Driving Conditions.....	6-46
Rocking the Vehicle .....	6-46
Smooth Cornering .....	6-47
Driving at Night .....	6-47
Driving in the Rain .....	6-47
Hydroplaning .....	6-48
Driving in Flooded Areas.....	6-48
Highway Driving .....	6-48
Winter Driving .....	6-49
Snow or Icy Conditions .....	6-49
Winter Precautions.....	6-51
Vehicle Load Limit.....	6-53
The Loading Information Label .....	6-53
Trailer Towing.....	6-57

## Before Driving

### Before Entering the Vehicle

- Make sure all windows, outer side mirror(s), and outside lights are clean and unobstructed.
- Remove frost, snow, or ice from both the front and rear windshield as well as the front side windows.
- Visually check the tires for uneven wear and damage.
- Check under the vehicle for any sign of leaks.
- Make sure there are no obstacles behind you if you intend to back up.

### Before Starting

- Make sure the hood, the trunk, and the doors are securely closed and locked.
- Adjust the position of the seat and steering wheel.
- Adjust the inside rearview mirror and outer side view mirrors.
- Verify all the lights work.
- Fasten your seat belt. Check that all passengers have fastened their seat belts.
- Check the gauges and indicators in the instrument panel and the messages on the cluster display when the vehicle is in the ON position.
- Check that any items you are carrying are stored properly or fastened down securely.

### WARNING

To reduce the risk of **SERIOUS INJURY** or **DEATH**, take the following precautions:

- **ALWAYS** wear your seat belt. All passengers must be properly belted whenever the vehicle is moving. For more information, refer to the “Seat Belts” section in chapter 3.
- Always drive defensively. Assume other drivers or pedestrians may be careless and make mistakes.
- Stay focused on the task of driving. Driver distraction can cause accidents.
- Leave plenty of space between you and the vehicle in front of you.

### WARNING

**NEVER** drink or take drugs and drive.

Drinking or taking drugs and driving is dangerous and may result in an accident and **SERIOUS INJURY** or **DEATH**.

Drunk driving is the number one contributor to the highway death toll each year. Even a small amount of alcohol will affect your reflexes, perceptions and judgment. Just one drink can reduce your ability to respond to changing conditions and emergencies. Your reaction time gets worse with each additional drink.

Driving while under the influence of drugs is as dangerous or more dangerous than driving under the influence of alcohol.

You are much more likely to have a serious accident if you drink or take drugs and drive. If you are drinking or taking drugs, don't drive. Do not ride with a driver who has been drinking or taking drugs. Choose a designated driver or call a taxi.

## Start/Stop Button



Whenever the front door is opened, the Start/Stop button will illuminate and will go off for a few seconds after the door is closed.

### WARNING

To turn the vehicle off in an emergency: Press and hold the Start/Stop button for more than two seconds OR Rapidly press and release the Start/Stop button three times (within three seconds).

If the vehicle is still moving, you can restart the vehicle without depressing the brake pedal by pressing the Start/Stop button with the gear in the N (Neutral) position.

---

### WARNING

- NEVER press the Start/Stop button while the vehicle is in motion except in an emergency. This will result in the vehicle turning off and loss of power assist for the steering and brake systems. This may lead to loss of directional control and braking function, which could cause an accident.
  - Before leaving the driver's seat, always make sure the gear is in the P (Park) position, set the parking brake, press the Start/Stop button to the OFF position, and take the Smart Key with you. Unexpected vehicle movement may occur if these precautions are not followed.
  - NEVER reach through the steering wheel for the Start/Stop button or any other control while the vehicle is in motion. The presence of your hand or arm in this area may cause a loss of vehicle control resulting in an accident.
-



## Start/Stop Button Positions

Button Position	Action	Notes
OFF	To turn off the vehicle, press the Start/Stop button with the vehicle shifted to P (Park). If the Start/Stop button is pressed with the vehicle shifted to D (Drive), R (Reverse) or N (Neutral), the gear automatically shifts to P (Park).	If the steering wheel is not locked properly when you open the driver's door, the warning chime sounds.
ACC	Press the Start/Stop button when the button is in the OFF position without depressing the brake pedal. Some of the electrical accessories are usable. The steering wheel unlocks.	If you leave the Start/Stop button in the ACC position for more than one hour, the battery power turns off automatically to prevent the battery from discharging. If the steering wheel does not unlock properly, the Start/Stop button does not work. Press the Start/Stop button while turning the steering wheel right and left to release.
ON	Press the Start/Stop button while it is in the ACC position without depressing the brake pedal. The warning lights can be inspected before the vehicle is started.	Do not leave the Start/Stop button in the ON position when the vehicle is not running to prevent the battery from discharging.
START	To start the vehicle, depress the brake pedal and press the Start/Stop button with the gear shifted to the P (Park) position.	If you press the Start/Stop button without changes as follows: <b>OFF &gt; ACC &gt; ON &gt; OFF</b> or <b>ACC</b>

### *i* Information

To prevent vehicle battery discharge, the Start/Stop button changes to the OFF position when the Start/Stop button is in the ACC or ON position with the gear in P (Park) for a certain period of time. When the function operates, the tail lights will turn off. To use the tail lights again, turn the headlight switch located on the steering column to the OFF and ON position again.

## Starting the Vehicle

### WARNING

- Always wear appropriate shoes when operating your vehicle. Unsuitable shoes, such as high heels, ski boots, sandals, flipflops, etc., may interfere with your ability to use the brake and accelerator pedals.
- Do not start the vehicle with the accelerator pedal depressed.  
The vehicle can move which can lead to an accident.

### *i* Information

- The vehicle will start by pressing the Start/Stop button, only when the smart key is in the vehicle.
- The vehicle may not start even if the smart key is in the vehicle but it is not near you (for example, in the cargo area).
- When the Start/Stop button is in the ACC or ON position, if any door is open, the system checks for the smart key. When the smart key is not in the vehicle, the  indicator will blink and the warning 'Key not in vehicle' will come on. When all doors are closed, the chime will also sound for a few seconds. Keep the smart key in the vehicle when in the ACC position or if the vehicle is in the ready mode (READY indicator on).

1. Always carry the smart key with you.
2. Make sure the parking brake is applied.
3. Make sure the gear is in P (Park).
4. Depress the brake pedal.
5. Press the Start/Stop button. If the vehicle starts, the READY indicator illuminates.

### *i* Information

- Always start the vehicle with your foot on the brake pedal. Do not depress the accelerator while starting the vehicle. Do not race the motor while warming it up.
- If ambient temperature is low, the  indicator may remain illuminated longer than the normal amount of time.

### NOTICE

To prevent damage to the vehicle:

- If the vehicle turns off while you are in motion, do not attempt to shift the gear to the P (Park) position.

If traffic and road conditions permit, you may put the gear in N (Neutral) while the vehicle is still moving and press the Start/Stop button in an attempt to restart the vehicle.

- Do not push or tow your vehicle to start the vehicle.

### NOTICE

To prevent damage to the vehicle:

Do not press the Start/Stop button for more than 10 seconds except when the stop light fuse is blown.

When the stop light fuse is blown, you cannot normally start the vehicle. Replace the fuse with a new one. If you are not able to replace the fuse, you can start the vehicle by pressing and holding the Start/Stop button for 10 seconds with the Start/Stop button in the ACC position.

Pressing the brake pedal many times when the vehicle is not in the ready mode (READY indicator off) increases the possibility of discharging the 12 V battery. For your safety always depress the brake pedal before starting the vehicle.

## *i* Information

Virtual Engine Sound System (VESS)

VESS generates virtual engine sound to make pedestrians aware. VESS operates when the vehicle can be driven. When the vehicle is in P (parking) gear status, VESS doesn't work.

## CAUTION

Always check your surroundings while driving, backing up, or before driving from a stop because your electric vehicle does not make vehicle sounds.

## Emergency starting

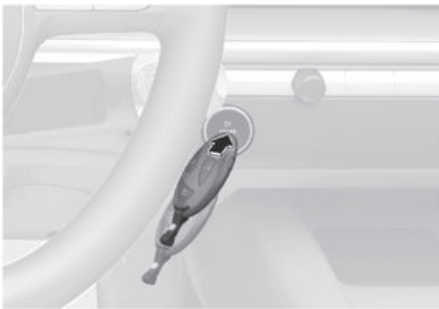

If the smart key battery is weak or the smart key does not work correctly, press the Start/Stop button with the smart key in the direction of the illustration shown above.

## Turning Off the Vehicle

1. Stop the vehicle and depress the brake pedal fully.
2. Shift to P (Park).
3. Press the Start/Stop button to the OFF position and apply the parking brake.
4. Make sure the **READY** indicator is turned off on the instrument cluster.

## CAUTION

If the **READY** indicator on the instrument cluster is still on, the vehicle is not turned off and can move when the gear is in any position except P (Park).

## Remote Start

Type A



Type B



You can start the vehicle using the Remote Start button of the smart key.

To start the vehicle remotely:

1. Press the door lock button within 32 ft. (10 m) from the vehicle.
2. Press and hold the remote start (Ⓜ) button within 4 seconds.

To turn off the vehicle:

Press the remote start button (Ⓜ) once.

### **i** Information

- The vehicle does not remotely start if the hood or trunk is opened.
- The vehicle must be in P (Park) for the remote start function to start.
- The vehicle displays "**Smart Key must be present to keep the vehicle running**" if you get in the vehicle without a registered smart key.
- The vehicle turns off if you do not get in the vehicle within 10 minutes after remotely starting the vehicle.

## Shift By Wire

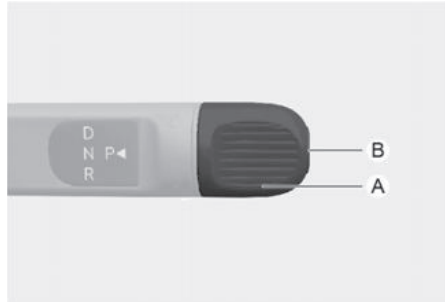

[A] Rotary shifter  
[B] P button

### Shift By Wire Operation

Depress the brake pedal whenever rotating the rotary shifter to change gear or selecting P.

### **⚠** WARNING

To reduce the risk of serious injury or death:

- ALWAYS check the surrounding areas near your vehicle for people, especially children, before shifting a vehicle into D (Drive) or R (Reverse).
- Before leaving the driver's seat, always make sure the vehicle is shifted to the P (Park) position, then apply the parking brake, then press the Start/Stop button to the OFF position. Unexpected and sudden vehicle movement can occur if these precautions are not followed.

### **P (Park)**

Always come to a complete stop before shifting into P (Park).

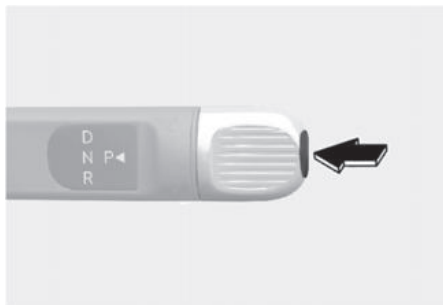

To shift the gear to P (Park), press the P button while depressing the brake pedal.

If you turn the vehicle off in R (Reverse), N (Neutral) or D (Drive), the gear will automatically shift to P (Park).

### **⚠ WARNING**

- Shifting into P (Park) while the vehicle is in motion may cause you to lose control of the vehicle.
- After the vehicle has stopped, always make sure the vehicle is in P (Park), apply the parking brake, and turn the vehicle off.
- When parking on an incline, shift the gear to P (Park) and apply the parking brake to prevent the vehicle from rolling downhill.

### **i Information**

For vehicles equipped with the Electronic Parking Brake (EPB), EPB is applied automatically when the gear is shifted to P (Park).

### **Automatic gear shift to P (Park)**

The gear is shifted to P (Park) automatically for safety reasons under the following conditions:

- When the vehicle is turned off with the gear in R (Reverse), D (Drive) or N (Neutral).
- When the driver's door is open with the vehicle on (READY indicator on), the gear in R (Reverse), D (Drive) or N (Neutral), and the vehicle at a standstill.
- When the driver's door is open with the gear in N (Neutral) and the vehicle is off.

In situations the gear must be in P (Park), always check if the gear is shifted to P (Park) by checking the instrument cluster.

### **R (Reverse)**

Use this position to drive the vehicle rearward.

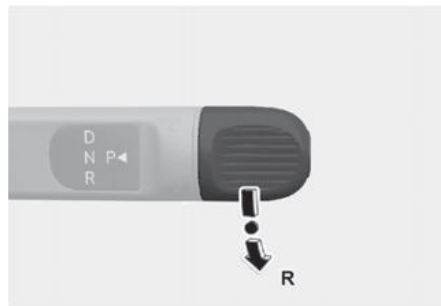

To shift the gear to R (Reverse), rotate the rotary shifter to R (Reverse) while depressing the brake pedal.

When the vehicle is stopped in the R (Reverse) position, if you open the driver's door, the gear may automatically shift to P (Park).

However, if the vehicle is in motion, the gear may not automatically shift to P (Park) to prevent gear damage.

**NOTICE**

Always come to a complete stop before shifting into or out of R (Reverse) to prevent damaging the gear.

**N (Neutral)**

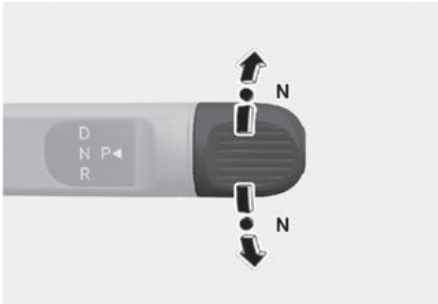

To shift the gear to N (Neutral), rotate the rotary shifter to N (Neutral) while depressing the brake pedal.

Always depress the brake pedal when you are shifting from N (Neutral) to another gear.

If you turn the vehicle off in N (Neutral), the gear will automatically shift to P (Park).

However, if you need to stay in N (Neutral) with the vehicle off, refer to the "To stay in N (Neutral) when vehicle is OFF" in the following description.

To rotate the rotary shifter to N (Neutral), rotate the rotary shifter once clockwise or counterclockwise.

If the current gear position is in D (Drive), rotate the rotary shifter counterclockwise. When the gear position is in R (Reverse), rotate the rotary shifter clockwise.

**To stay in N (Neutral) when vehicle is OFF**

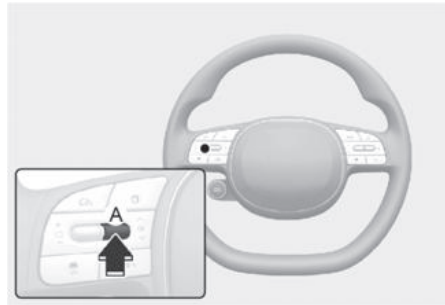

[A] OK button

If you want to stay in N (Neutral) after the vehicle is in the ACC state, do the following:

1. Turn off Auto Hold and release Electronic Parking Brake when the vehicle is on (**READY** indicator on).
2. Rotate the rotary shifter to N (Neutral) while depressing the brake pedal.
3. Take your foot off the brake pedal. The message "**Press and hold OK button on the steering wheel to stay in Neutral**" appears on the cluster display.
4. Press and hold the OK button on the steering wheel for more than 1 second.
5. When the message "**Vehicle will stay in (N). Change gear to cancel**" appears on the cluster display, press the Start/Stop button while depressing the brake pedal.

However, if you open the driver's door within 3 minutes in the ACC state, the gear automatically shifts to P (Park) and the Start/Stop button changes to the OFF position.

### NOTICE

- With the gear in N (Neutral) the Start/Stop button will be in the ACC position. Note that the doors cannot be locked in the ACC position or the battery (12 V) may discharge if left in the ACC position for a long period.
- Before entering an automatic car wash, release the Electronic Parking Brake (EPB) manually. If EPB is applied, it may damage the vehicle or automatic car wash.

### *i* Information

When the Electronic Parking Brake (EPB) is applied, press the EPB switch while depressing the brake pedal.

The Electronic Parking Brake (EPB) must be released manually because EPB does not release automatically even though the gear is shifted to N (Neutral).

### **D (Drive)**

This is the normal driving position.

The regenerative braking system automatically activates according to the road conditions.

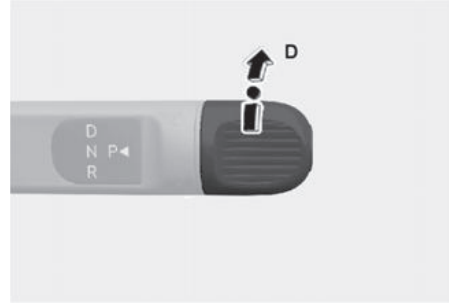

To shift the gear to D (Drive), rotate the rotary shifter to D (Drive) while depressing the brake pedal.

When the vehicle is stopped in the D (Drive) position, if you open the driver's door, the gear may automatically shift to P (Park).

However, if the vehicle is in motion, the gear may not automatically shift to P (Park) to prevent gear damage.

### NOTICE

Always come to a complete stop before shifting into D (Drive).

### CAUTION

When you drive after stopping on a steep incline, if you do not depress the accelerator pedal or brake pedal, the vehicle may roll backwards resulting in a collision.

### **Shift-lock system**

For your safety, your vehicle has a shift-lock system which prevents shifting the gear from P (Park) or N (Neutral) into R (Reverse) or D (Drive) unless the brake pedal is depressed.

To shift from P (Park) or N (Neutral) into R (Reverse) or D (Drive), from R (Reverse) into D (Drive) or from D (Drive) into R (Reverse):

1. Depress and hold the brake pedal.
2. Start the vehicle.
3. Shift the gear in R (Reverse) or D (Drive).

### **i Information**

The gear cannot be shifted while the charging cable is connected.

---

### **When the battery (12 V) is discharged**

You cannot shift gears when the battery is discharged.

Jump start your vehicle (refer to the "Jump Starting (12 V battery)" section in chapter 8) or contact an authorized HYUNDAI dealer.

### **Parking**

Always come to a complete stop and continue to depress the brake pedal. Shift the gear to P (Park), apply the parking brake, and press the Start/Stop button to the OFF position. Take the key with you when leaving the vehicle.

## **Cluster Display Messages Information**

### **Press brake pedal to change gear**

This message is displayed when the brake pedal is not depressed while shifting out of P (Park).

Depress the brake pedal and then shift the gear.

### **Shift to P after stopping**

This message is displayed when the gear is shifted to P (Park) while the vehicle is moving.

Stop the vehicle before shifting to P (Park).

### **Shifter system malfunction**

This message is displayed when the shift gear does not properly operate in the P (Park) position.

Have the vehicle inspected by an authorized HYUNDAI dealer.

### **Check shifter dial**

This message is displayed when there is a malfunction with the rotary shifter.

Have the vehicle inspected by an authorized HYUNDAI dealer.

### **Check P button**

This message is displayed when there is a problem with the P button.

Have the vehicle inspected by an authorized HYUNDAI dealer.

### **Rotary shifter stuck**

This message is displayed when the rotary shifter does not return back to its normal position.

Have the vehicle inspected by an authorized HYUNDAI dealer.



## Good Driving Practices

- Never shift the gear from P (Park) or N (Neutral) to any other position with the accelerator pedal depressed.
- Never shift the gear into P (Park) when the vehicle is in moving. Completely stop before shifting into R (Reverse) or D (Drive).
- Do not shift the gear to N (Neutral) when driving. If the gear is shifted to N (Neutral) while driving. Doing so may increase the risk of an accident.  
Also, shift the gear back to D (Drive) while the vehicle is moving may severely damage the gear.
- Never attempt to select a gear that is opposite the direction of the vehicle motion. Check the gear position before driving. Stop the vehicle before shifting to the desired gear. The vehicle may turn off, causing a collision.
- Do not drive with your foot resting on the brake pedal. Even light, but consistent pedal pressure can result in the brakes overheating, brake wear and possibly even brake failure.
- Always apply the parking brake when leaving the vehicle. Do not depend on placing the shift gear in P (Park) to keep the vehicle from moving.
- Exercise extreme caution when driving on a slippery surface. Be especially careful when braking, accelerating, or shifting gears. On a slippery surface, an abrupt change in vehicle speed can cause the drive wheels to lose traction and may cause loss of vehicle control resulting in an accident.
- Optimum vehicle performance and economy is obtained by smoothly depressing and releasing the accelerator pedal.

## WARNING

To reduce the risk of SERIOUS INJURY or DEATH:

- ALWAYS wear your seat belt. In a collision, an unbelted occupant is significantly more likely to be seriously injured or killed than a properly belted occupant.
- Avoid high speeds when cornering or turning.
- Do not make quick steering wheel movements, such as sharp lane changes or fast, sharp turns.
- The risk of rollover is greatly increased if you lose control of your vehicle at highway speeds.
- Loss of control often occurs if two or more wheels drop off the roadway and the driver over steers to reenter the roadway.
- In the event your vehicle leaves the roadway, do not steer sharply. Instead, slow down before pulling back into the travel lanes.
- HYUNDAI Vehicle recommends you to follow all posted speed limits.

## Regenerative Braking System (Paddle Shifter)

Regenerative braking system operates the paddle shifter to control the regenerative braking intensity of the vehicle. It improves the energy efficiency of the vehicle and helps the driver to have a better driving experience.

### **i** Information

The regenerative braking system uses the electric motor to engage the brake. The electric motor converts the kinetic energy generated from decelerating the vehicle to electricity and charges the high voltage battery.

## Using Regenerative Braking System

### **Operating paddle shifter**

Operate the paddle shifter as shown below to use the regenerative braking system.



- Pull the left paddle shifter (+) once to raise the regenerative braking intensity level by 1. It will increase decelerating intensity.
- Pull the right paddle shifter (-) once to lower the regenerative braking intensity level by 1. It will decrease decelerating intensity.

- Pull and hold the left paddle shifter (+) for over 0.5 seconds to keep raising the regenerative braking intensity level. Holding the paddle shifter brings the vehicle to stop. (For more information, refer to the "One Pedal Driving" section in this chapter.)
- While the smart regeneration system is turned on, pull and hold the right paddle shifter (-) for over 1 second to turn off the smart regeneration system. (For more information, refer to the "Smart Regeneration System" section in this chapter.)

### **Checking the amount of regenerative braking**



The selected regenerative braking level appears on the instrument cluster.

- When the vehicle is turned off and on again after the regenerative braking level is in 0, the braking level is changed to 1.
- When the vehicle is turned off and on again after the i-PEDAL is on, the braking level is changed to 3.

## Regenerative Braking System Limitations

Regenerative braking intensity cannot be changed using the paddle shifter in the following situations when:

- The (+) and (-) paddle shifters are pulled at the same time.
- The vehicle is decelerating by depressing the brake pedal.
- Smart Cruise Control is activated.
- The regenerative braking is continuously operated with the battery fully charged
- The SNOW mode is activated

Initial setting of the regenerative braking level and adjustable range may vary according to the selected Drive mode.

Drive Mode	Adjustable Range
SNOW	0 to 1
ECO	0 to 3
NORMAL	0 to 3
SPORT	0 to 3

For more information, refer to the "All Wheel Drive (AWD)" section in this chapter.

## One Pedal Driving

One pedal driving operates the paddle shifter while coasting to control the intensity of regenerative braking. It assists the driver to stop the vehicle without depressing the brake.

### *i* Information

Coasting is the process of driving a vehicle without the brake pedal and the accelerator pedal depressed. Coasting uses the inertia of driving energy instead of the vehicle power.

### **Using one pedal driving**

Pull and hold the left paddle shifter (+) for over 0.5 seconds while coasting to enable the one pedal driving mode.

- Release the paddle shifter when the vehicle speed is above 1.8 mph (3 km/h) to return to the previously set regenerative braking level.
- If the vehicle speed is below 1.8 mph (3 km/h), the vehicle will keep engaging the brake although the driver releases the paddle shifter.
- Releasing the paddle shifter after the vehicle comes to a stop will maintain the vehicle stationary.

### CAUTION

- The vehicle may not come to a stop although the one pedal driving function is active, depending on the condition of the vehicle and the road. Check the surroundings and depress the brake pedal to decelerate.
- If the driver depresses the accelerator pedal while pulling and holding the left paddle shifter (+) to increase the braking level, one pedal driving function operates same as i-PEDAL function. In this case, the vehicle speed is no longer controllable through the paddle shifter.

### **One pedal driving limitations**

In the following conditions, the vehicle may not come to a stop although the one pedal driving function is active. Depress the brake pedal to stop the vehicle when:

- Driving on a slope, or when the vehicle is repeatedly driven and stopped.
- The vehicle is driving through the end of the slope.
- Driving on a slippery surface such as an icy, rainy, or muddy road.
- The wheels are not properly aligned.
- A wheel slip or wheel spin occurs.
- The weight on board is heavy.
- The vehicle is tilted to one side.
- The tire is worn out.

### **Automatic engagement of EPB**

Use one pedal driving function to bring the vehicle to a stop and automatically engage the Electronic Parking Brake (EPB).

After the vehicle is stopped, EPB is automatically applied when any of the following conditions are satisfied:

- The driver's seatbelt is unfastened and the driver's door is open.
- The gear shifts to N (Neutral).
- The hood is open.
- The trunk is open.
- 5 minutes have passed after the vehicle has stopped.
- One pedal driving is limited due to other reasons.

### **Using i-PEDAL**

i-PEDAL assists the driver to accelerate, decelerate, and stop the vehicle with only the accelerator pedal.

### **Turning on/off the i-PEDAL**

- Turning on i-PEDAL:

Pull the left paddle shifter () once when the regenerative braking level is at 3. i-PEDAL is turned on and the instrument cluster displays the 'i-PEDAL' message. i-PEDAL is not available while the smart regeneration system is on. Turn off the smart regeneration system first before using i-PEDAL.

- Turning off i-PEDAL:

Pull the right paddle shifter () once while the function is on. Otherwise, shift the gear to R (Reverse) then to D (Drive) while the function is on. i-PEDAL is disabled and regenerative braking level is set to 3.

### **⚠ CAUTION**

- Depending on the vehicle and road condition, the vehicle may not come to a stop although the i-PEDAL function is active. Check surroundings and depress the brake pedal to control the vehicle speed.
- Do not use i-PEDAL on slippery roads.

### **i-PEDAL limitations**

In the following conditions, the vehicle may not come to a stop although the i-PEDAL is properly activated. Depress the brake to stop the vehicle when:

- Driving on a slope, or when the vehicle is repeatedly driven and stopped.
- The vehicle is driving through the end of the slope.
- Driving on a slippery surface such as an icy, rainy, or muddy road.
- The wheels are not properly aligned.
- A wheel slip or wheel spin occurs.
- The weight on board is heavy.
- The vehicle is tilted to the side.
- The tire is worn out.

## Smart Regeneration System

The smart regeneration system recognizes vehicle-to-vehicle distance, road gradient, and speed cameras and controls the regenerative braking level while coasting. It reduces unnecessary depressing of pedals to improve energy efficiency and driver convenience.

### **i** Information

- Coasting is the process of driving a vehicle without the brake pedal and the accelerator depressed. Coasting uses the inertia of driving energy instead of the vehicle power.
- The regenerative braking system uses the electric motor to engage the brake. The electric motor converts the kinetic energy generated from decelerating the vehicle to electricity and charges the high voltage battery.



## Smart Regeneration System On/Off

Operate the paddle shifter as shown below to use the smart regeneration system.

- Turning on the smart regeneration system: While the **READY** indicator is on, shift the gear to D (Drive), and pull and hold the right paddle shifter () for over a second.



The smart regeneration system turns on and the regenerative braking level is displayed as 'AUTO'.

- Turning off the smart regeneration system: While the smart regeneration system is on, pull and hold the right paddle shifter () for over a second. The instrument cluster displays the regenerative braking level instead of 'AUTO', and the smart regeneration system turns off.
- Using one pedal driving: While the smart regeneration system is on, pull and hold the left paddle shifter () for over 0.5 seconds (For more information, refer to the "One Pedal Driving" section in this chapter.)  
i-PEDAL is not available while the smart regeneration system is on. Turn off the smart regeneration system first before using i-PEDAL.

## Smart Regeneration System Operating Condition

When the regenerative braking level is displayed as AUTO and the vehicle speed is above 6 mph (10 km/h), the system automatically controls the regenerative braking level under the following conditions:

- The road gradient changes
- Distance from the vehicle ahead reduces or increases
- Speed of the vehicle ahead reduces or increases

### CAUTION

- When the forward safety warning light is ON, the smart regeneration system does not work properly. Depress the brake pedal for deceleration.
- The function that adjusts the regenerative braking intensity depending on the road gradient is only effective when the regenerative braking level is 0. Braking intensity does not significantly change depending on the road gradient if the regenerative braking level is 1 or above.

## Smart Regeneration Level Settings



The instrument cluster displays 'AUTO' (1) when the smart regeneration system is on. Depending on the conditions, the system adjusts the regenerative braking level (2). The indicator light (3) illuminates when the vehicle recognizes a vehicle.

### **Smart regeneration default setting**

The default braking level of the smart regeneration system can be changed. Set the default braking level to the lowest and let the system adjust the braking intensity automatically.

To change the default level of the smart regeneration system, pull the right paddle shifter () once while the system is on.

### **Smart regeneration intensity setting**

Regenerative braking intensity of the smart regeneration system can be adjusted to match the driver's preference. Adjust the braking intensity makes the decelerating faster or slower.

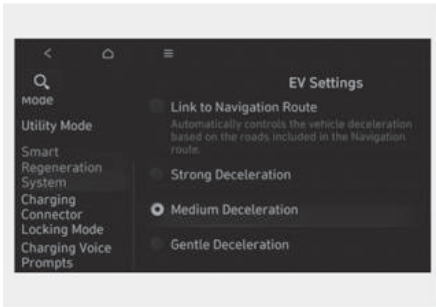

To adjust the regenerative braking level of the smart regeneration system, go to **Setup > EV > Smart Regeneration System** from the infotainment system.

## Pausing Smart Regeneration System

The smart regeneration system is temporarily turned off in the following conditions. While the system is turned off, the driver must keep eyes on the road and depress the brake pedal to decelerate.

- The gear is shifted to N (Neutral), R (Reverse) or P (Park)
- Smart Cruise Control is ON
- ESC (Electronic Stability Control) is operating
- ABS is operating

## Front Sensors

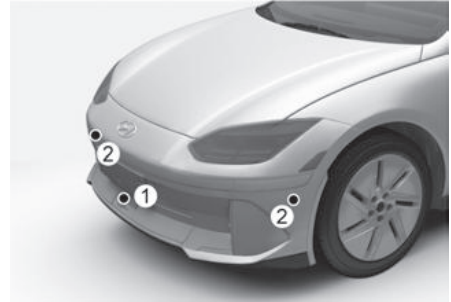

- (1) Front radar
- (2) Front corner radar

Front sensors recognize the distance from the vehicle ahead to control the regenerative braking intensity. If the sensor is covered with snow, rain, or other foreign substances, the performance of the sensors may deteriorate, and the smart regeneration system may turn off. Always keep the sensors clean.

## System Check Message

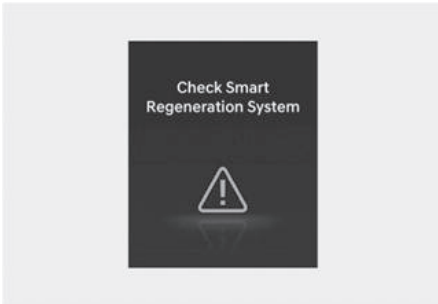

When the front radar is covered or blocked, the smart regeneration system may be temporarily disabled. The '**Check Smart Regeneration System**' warning message may appear, and the regenerative braking level is displayed on the instrument cluster.

The system operates normally when such foreign material is removed, and the system is turned on by pulling and holding the right paddle shifter (  ) for over one second.

If the smart regeneration system does not operate normally after the sensor has been uncovered or unblocked, have the vehicle inspected by an authorized HYUNDAI dealer.

## Smart Regeneration System Precautions

- Always monitor the distance to vehicles ahead on the road. The smart regeneration system is not a substitute for safe driving practices, but a supplemental function only.
- Always maintain a safe distance from the vehicles ahead and adjust your vehicle speed to the road conditions. The smart regeneration system may not recognize unexpected and sudden situations or complex driving situations.

## General precautions

- Always maintain a safe distance from the vehicles ahead and adjust your vehicle speed depending on the road conditions.
- Always prepare for unexpected situations and depress the brake pedal to decelerate when necessary. The smart regeneration system cannot react to pedestrians, vehicles making a sudden stop and vehicles coming from the opposite lane.
- If the vehicle ahead frequently changes the lane, keep your eyes forward to be prepared for hazardous situations. In this case, the smart regeneration system may respond late and may inappropriately respond to vehicle movements from the side lanes.
- The driver must depress the brake pedal when stopping the vehicle.
- Depress the brake pedal to decelerate in the following conditions when:
  - The front part of the vehicle is lifted up because of the cargo loaded on the rear part of the vehicle.
  - You are operating the steering wheel.
  - You are not driving in the center of the lane.
  - You are driving on a narrow or curved road.
- The smart regeneration system may be temporarily turn off when exposed to strong electromagnetic waves.
- If the vehicle starts coasting near the speed camera and engages the brake with the smart regeneration system, the vehicle may not be able to keep the speed limit. Always comply with the road and traffic law.



### Sensor precautions

- Never disassemble the radar or radar assembly, and never apply any impact on it.
- If there is impact on or near the radar, the sensors may be damaged or not be properly aligned near the radar, even though a warning message does not appear on the instrument cluster, the Smart Regeneration System may not operate properly. Have the vehicle inspected by an authorized HYUNDAI dealer.
- If the radars have been replaced or repaired, have the vehicle inspected by an authorized HYUNDAI dealer.
- Use only genuine parts to repair the bumper where the radar is located.
- Do not install a license plate frame or other objects such as bumper sticker, film, bumper guard, or bumper wrap near the radar.
- The Smart Regeneration System may not work properly if the bumper has been replaced, or the surroundings of the radar has been damaged or painted.
- Do not spray the sensors or the surrounding area directly with high pressure water.

### Detecting vehicle

- The front sensors may not detect the vehicle ahead or may suddenly detect the vehicle ahead, such as when the smart regeneration system responds slowly, when driving on a hill ends, or when driving through a curve. The regenerative braking intensity may increase and decelerate your vehicle.
- Some vehicles in your lane may not be detected by the sensors:

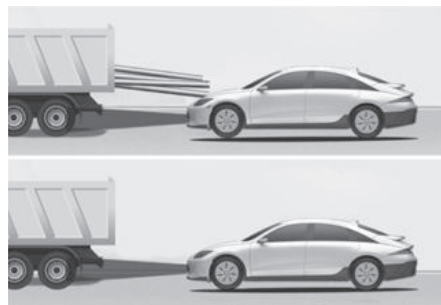

- Narrow vehicles such as motorcycles or bicycles
- Vehicles offset to one side
- Slow-moving vehicles or sudden decelerating vehicles
- Vehicles with small rear profile such as trailers with no loads
- When a vehicle in front of you merges out of the lane, the front sensors may not detect the new stopped vehicle that is now in front of your vehicle.

### Driving on curves

- The front sensors may not detect the vehicle ahead if you are coasting on a curve. The regenerative braking intensity may automatically decrease and accelerate the vehicle.

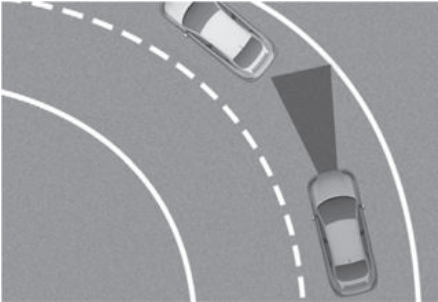

- On curves, if a vehicle is detected in an adjacent lane, the regenerative braking intensity may increase and decelerate your vehicle.



- If the front sensors suddenly detect the vehicle ahead, the regenerative braking intensity may increase and decelerate your vehicle.

### Driving on hills

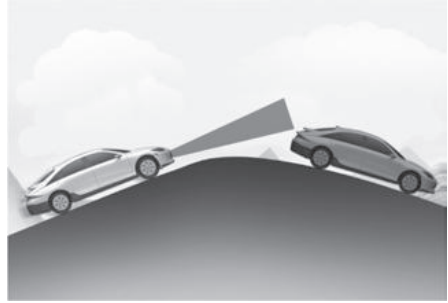

When coasting uphill or downhill, the front sensors may not detect the vehicle ahead or suddenly detect the vehicle ahead at the end of the incline or at the point where the incline changes. The regenerative braking intensity is adjusted automatically changing your vehicle speed. Brake as needed to reduce your driving speed.

### Changing lanes

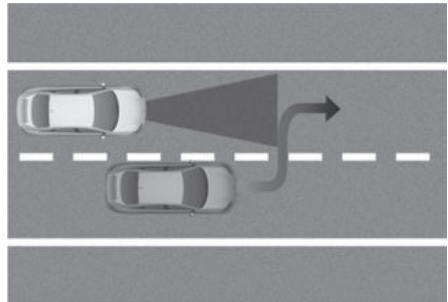

- When a vehicle moves into your lane from an adjacent lane, it cannot be detected by the sensors until it is in the sensor's detection range.
- The smart regeneration system may not immediately detect the vehicle when your vehicle changes lanes abruptly.

## Braking System

### Power-Assist Brakes

Your vehicle has power-assisted brakes that adjust automatically through normal usage.

In the event of a vehicle power failure, the power assist for the brakes will not work. You can still stop your vehicle, but it will require greater force and increased pedal travel than normal. The stopping distance, however, will be longer than with power brakes.

#### Information

- When the brake pedal is depressed under certain driving conditions or weather conditions, you may temporarily hear a noise. This is normal and does not indicate a problem with your brakes.
- While driving on a road with deicing chemicals, brake noise or abnormal tire wear may occur due to deicing chemicals. In a safe traffic condition, additionally apply the brakes to remove deicing chemicals on the brake discs and pads.

#### WARNING

Take the following precautions:

- Do not drive with your foot resting on the brake pedal. This will create abnormal high brake temperatures, excessive brake lining and pad wear, and increased stopping distances. So increase the regeneration braking level with the left paddle shifter(  ) to decrease the speed.

- When descending down a long or steep hill, use the paddle shifter to increase the regeneration braking level in order to decrease your speed without using the brake pedal excessively. Applying the brakes continuously will cause the brakes to overheat and could result in a temporary loss of braking performance.
- Wet brakes may impair the vehicle's ability to safely decelerate. Because wet brakes increase braking distance and cause noise troubles, select 0 step of the regenerative braking system and depress the brake pedal around 10 times, with keeping the safe distance from other vehicles, lightly in order to dry the braking system. Such procedure may decrease the driving distance by restraining the regenerative braking system, which is not a system malfunction. Inspect the braking system after car wash or driving over wet road conditions.

#### NOTICE

- Do not continue depressing the brake pedal if the vehicle is off (READY indicator off). The battery may be discharged.
- Noise and vibration generated during braking is normal.
- Under normal operation, electric brake pump noise and motor vibration may occur temporarily in below cases.
  - When the pedal is depressed suddenly.
  - When the pedal is repeatedly depressed in short intervals.
  - When the ABS function is activated while braking.

## Disc Brakes Wear Indicator

When your brake pads are worn and new pads are required, you will hear a high pitched warning sound from your front or rear brakes. You may hear this sound come and go or it may occur whenever you depress the brake pedal.

### NOTICE

To avoid costly brake repairs, do not continue to drive with worn brake pads.

### *i* Information

Always replace brake pads as complete front or rear axle sets.

### WARNING

Frequent braking may deform components and worn the disc brake causing vibration when braking. Observe the speed limit to prevent brake damage from excessive braking.

Brake wear, noise, vibration from excessive braking or deformation of the brakes caused by repeatedly braking in high speed, racing on tracks, etc. can be excluded from warranty coverage.

## Electronic Parking Brake (EPB)

### Applying the parking brake

To apply EPB (Electronic Parking Brake):



1. Depress and hold the brake pedal.
2. Pull up the EPB switch.

Make sure the Parking Brake warning light comes on.

**EPB (Electronic Parking Brake) may be automatically applied when:**

- Requested by other systems.
- The driver turns the vehicle off while Auto Hold is operating.

### Emergency braking

If there is a problem with the brake pedal while driving, emergency braking is possible by pulling up and holding the EPB switch. Braking is possible only while you are holding the EPB switch. However, braking distance will be longer than normal.

### WARNING

To reduce the risk of **SERIOUS INJURY** or **DEATH**, do not operate the EPB while the vehicle is moving except in an emergency situation. It could damage the brake system and lead to an accident.

## *i* Information

During emergency braking, the Parking Brake warning light will illuminate to indicate that the system is operating.

## NOTICE

If you continuously notice a noise or burning smell when the EPB is used for emergency braking, have the system inspected by an authorized HYUNDAI dealer.

### Releasing the parking brake

To release EPB (Electronic Parking Brake):



1. Press the Start/Stop button to the ON or START position.
2. Press the EPB switch while depressing the brake pedal.

Make sure the Parking Brake warning light goes off.

To release EPB (Electronic Parking Brake) automatically:

- Gear in P (Park)

With the vehicle on (READY indicator on) depress the brake pedal and shift out of P (Park) to R (Reverse) or D (Drive).

- Gear in N (Neutral)

With the vehicle on (READY indicator on) depress the brake pedal and shift out of N (Neutral) to R (Reverse) or D (Drive).

- Satisfy the following conditions
  1. Ensure seat belts are fastened and the doors, hood and trunk are closed.
  2. With the vehicle on (READY indicator on), depress the brake pedal and shift out of P (Park) to R (Reverse), D (Drive) or Manual shift mode.
  3. Depress the accelerator pedal.

Make sure the Parking Brake warning light goes off.

## *i* Information

- You can engage EPB even though the Start/Stop button is in the OFF position (only if battery power is available), but you cannot release it.
- Depress the brake pedal and release the parking brake manually with the EPB switch before you drive downhill or when backing up.

## NOTICE

- If the Parking Brake warning light is still on even though the EPB has been released, have the system inspected by an authorized HYUNDAI dealer.
- Do not drive your vehicle with EPB applied. It may cause excessive brake pad and brake rotor wear.

### Warning messages

To release EPB, close the doors, hood and trunk and fasten the seatbelt

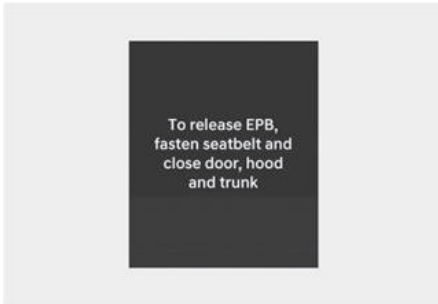

If the driver's seat belt is unfastened, or the hood, trunk, doors are open, and you try to drive with EPB applied, a warning sounds and a message appears.

### WARNING

To prevent serious injury or death from unintended vehicle movement:

- Always come to a complete stop and continue to depress the brake pedal before parking, shift the gear into P (Park), pull up the EPB switch, and press the Start/Stop button to the OFF position. Take the key with you when leaving the vehicle.
- Never allow anyone who is unfamiliar with the vehicle to touch the EPB switch.
- Only release EPB when you are seated inside the vehicle with your foot firmly on the brake pedal.

### NOTICE

Driving with the parking brake on may overheat the braking system and cause premature wear or damage to brake parts.

### Information

- In winter, the EPB related device may freeze and cannot be released. Do not use the EPB but park on a flat surface with the gear in P (Park). Use wheel chocks under the wheels if necessary. If the EPB applies automatically when the gear is shifted to P (Park), turn off the Auto Hold, and press the EPB switch to release the parking brake.
- A clicking sound may be heard while operating or releasing the EPB. These conditions are normal and indicate that EPB is functioning properly.
- When leaving your keys with a parking attendant or assistant, be sure to inform him/her how to operate the EPB.

### AUTO HOLD turning Off! Press brake pedal

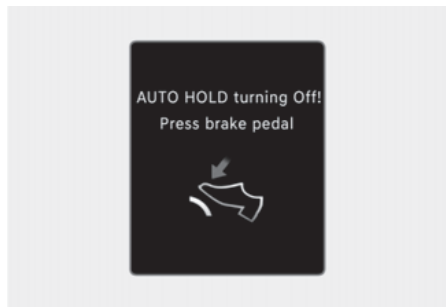

When the conversion from Auto Hold to EPB is not working properly a warning will sound and a message will appear.

### Parking brake automatically engaged

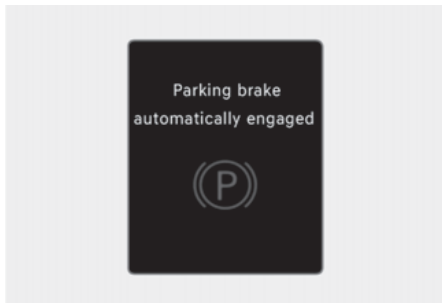

When EPB is applied while Auto Hold is activated, a warning will sound and a message will appear.

### EPB malfunction

Electronic Parking Brake (EPB) warning light illuminates if the Start/Stop button is pressed to the ON position and goes off in about 3 seconds if the system is operating normally.

If the EPB warning light remains on, comes on while driving, or does not come on when the Start/Stop button is pressed to the ON position, this indicates that the EPB may have malfunctioned.

If this occurs, have the system inspected by an authorized HYUNDAI dealer.

The EPB warning light may illuminate when the ESC indicator comes on to indicate that ESC is not working properly, but it does not indicate a malfunction of EPB.

### NOTICE

- If the Parking Brake warning light does not illuminate or blinks after the EPB switch has been pulled, the EPB may not be applied.

- If the EPB warning light is still on or the Parking Brake warning light blinks when the EPB warning light is on, press the switch, and then pull it up. Repeat this one more time. If the EPB warning does not go off, have the system inspected by an authorized HYUNDAI dealer.

### Parking brake warning light



Check the Parking Brake warning light by pressing the Start/Stop button to the ON position.

This light will be illuminated when the parking brake is applied with the Start/Stop button in the START or ON position.

Before driving, be sure the parking brake is released and the Parking Brake warning light is OFF.

If the Parking Brake warning light remains on after the parking brake is released while the motor is running, there may be a malfunction in the brake system. Immediate attention is necessary.

If at all possible, cease driving the vehicle immediately. If that is not possible, use extreme caution while operating the vehicle and only continue to drive the vehicle until you can reach a safe location.

### When the EPB (Electronic Parking Brake) does not release

If the EPB does not release normally, contact an authorized HYUNDAI dealer by loading the vehicle on a flatbed tow truck and have the system inspected.

## Auto Hold

Auto Hold maintains the vehicle in a standstill even though the brake pedal is not depressed after the driver brings the vehicle to a complete stop by depressing the brake pedal.

### To apply:



1. With the driver's door and hood closed, depress the brake pedal and then press the AUTO HOLD switch. The white AUTO HOLD indicator will come on and the system will be in the standby position.



- (1) White
  - (2) Green
2. When you stop the vehicle completely by depressing the brake pedal, Auto Hold maintains the brake pressure to hold the vehicle stationary. The indicator changes from white to green.
  3. The vehicle will remain stationary even if you release the brake pedal.

4. If EPB is applied, Auto Hold will be released.

### To release:

If you depress the accelerator pedal with the gear in D (Drive) or Manual shift mode, the Auto Hold will be released automatically and the vehicle will start to move. The AUTO HOLD indicator changes from green to white.

### WARNING

Always look around your vehicle before depressing the accelerator pedal to release Auto Hold.

### To cancel:



- (1) Off

1. Depress and hold the brake pedal.
2. Press the AUTO HOLD switch.

The AUTO HOLD indicator will turn off.

### WARNING

To prevent unintended vehicle movement, always depress your foot on the brake pedal to cancel the Auto Hold before you:

- Drive downhill.
- Drive the vehicle in R (Reverse).
- Park the vehicle.



## *i* Information

- The Auto Hold does not operate when:
  - The gear is in P (Park)
  - EPB is applied
- For your safety, the Auto Hold automatically switches to EPB when:
  - The driver's door is opened
  - The tail gate is opened
  - The hood is opened
  - The vehicle is in a standstill for more than 10 minutes
  - The vehicle is standing on a steep slope
  - The vehicle moved several times

The Parking Brake warning light comes on, the AUTO HOLD indicator changes from green to white, and a warning sounds and a message appears to inform you that EPB has been automatically engaged. Before driving, depress the brake pedal, check the surrounding area and release the parking brake manually with the EPB switch.

## NOTICE

If the AUTO HOLD indicator changes to yellow, or the driver's door, hood, or trunk open detection system malfunctions, Auto Hold does not work properly. Contact an authorized HYUNDAI dealer.

## WARNING

Depress the accelerator pedal slowly when you start the vehicle.

## Warning messages

### Parking brake automatically engaged

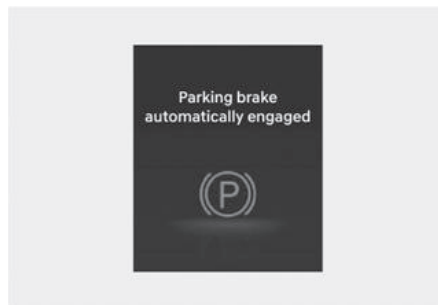

When EPB is applied while Auto Hold is activated, a warning will sound and a message will appear.

### AUTO HOLD turning Off! Press brake pedal

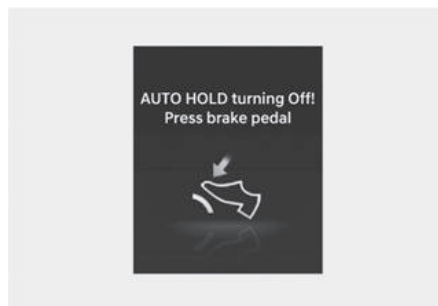

When the conversion from Auto Hold to EPB is not working properly a warning will sound and a message will appear.

When this message is displayed, Auto Hold and EPB may not operate. For your safety, depress the brake pedal.

### Press brake pedal to deactivate AUTO HOLD



If you did not apply the brake pedal when you release Auto Hold by pressing the AUTO HOLD switch, a warning will sound and a message will appear.

### Brake Disc Cleaning

Use the Brake Disc Cleaning function if noise is generated when depressing the brake while driving or if the brake disc gets rusty. It helps reduce the noise and rust. Regenerative braking is restrained while Brake Disc Cleaning is operated, which may lower the electric energy efficiency. Press and hold the AUTO HOLD button for over 3 seconds.

- Brake Disc Cleaning starts operating when the message "**Brake disc cleaning**" is displayed on the instrument cluster.
- Regenerative braking is restrained while the brake is depressed about 10 times while driving (it may differ depending on driving conditions). It helps reduce the noise and rust.
- Brake Disc Cleaning function will turn off automatically when the operation is completed. It can also be turned off before operation is completed by turning off the vehicle or pressing the AUTO HOLD button for over 3 seconds.

### Anti-Lock Brake System (ABS)

#### WARNING

Anti-Lock Braking System (ABS) or Electronic Stability Control (ESC) system will not prevent accidents due to improper or dangerous driving maneuvers. Even though vehicle control is improved during emergency braking, always maintain a safe distance between you and objects ahead of you. Vehicle speeds should always be reduced during extreme road conditions. The braking distance for vehicles equipped with ABS or ESC may be longer than for those without these systems in the following road conditions.

Drive your vehicle at reduced speeds during the following conditions:

- Rough, gravel or snow-covered roads.
- On roads where the road surface is pitted or has different surface height.
- Tire chains are installed on your vehicle.

The safety features of ABS or ESC equipped vehicle should not be tested by high speed driving or cornering. This could endanger the safety of yourself or others.

---

ABS is an electronic braking system that helps prevent a braking skid. ABS allows the driver to steer and brake at the same time.

## Using ABS

To obtain the maximum benefit from your ABS in an emergency situation, do not attempt to modulate your brake pressure and do not try to pump your brakes. Depress your brake pedal as hard as possible.

When you apply your brakes under conditions which may lock the wheels, you may hear sounds from the brakes, or feel a corresponding sensation in the brake pedal. This is normal and it means your ABS is active.

ABS does not reduce the time or distance it takes to stop the vehicle.

Always maintain a safe distance from the vehicle in front of you.

ABS will not prevent a skid that results from sudden changes in direction, such as trying to take a corner too fast or making a sudden lane change. Always drive at a safe speed for the road and weather conditions.

ABS cannot prevent a loss of stability. Always steer moderately when braking hard. Severe or sharp steering wheel movement can still cause your vehicle to veer into oncoming traffic or off the road.

On loose or uneven road surfaces, operation of the anti-lock brake system may result in a longer stopping distance than for vehicles equipped with a conventional brake system.

The ABS (ABS) warning light will stay on for several seconds after the Start/Stop button is in the ON position.

During that time, ABS will go through self-diagnosis and the light will go off if everything is normal. If the light stays on, you may have a problem with your ABS. Contact an authorized HYUNDAI dealer as soon as possible.

## WARNING

If the ABS (ABS) warning light is on and stays on, you may have a problem with the ABS. Your power brakes will work normally. To reduce the risk of serious injury or death, contact your authorized HYUNDAI dealer as soon as possible.

## NOTICE

When you drive on a road having poor traction, such as an icy road, and apply your brakes continuously, ABS will be active continuously and the ABS (ABS) warning light may illuminate. Pull your vehicle over to a safe place and turn the vehicle off.

Restart the vehicle. If the ABS warning light is off, then your ABS system is normal.

Otherwise, you may have a problem with your ABS system. Contact an authorized HYUNDAI dealer as soon as possible.

## Information

When you jump start your vehicle because of a drained battery, the ABS (ABS) warning light may turn on at the same time. This happens because of the low battery voltage. It does not mean your ABS is malfunctioning. Have the battery recharged before driving the vehicle.

## Electronic Stability Control (ESC)

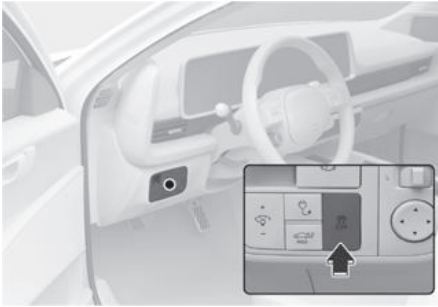

Electronic Stability Control helps to stabilize the vehicle during cornering maneuvers.

ESC checks where you are steering and where the vehicle is actually going. ESC applies braking pressure to any one of the vehicle's brakes and intervenes in the electric vehicle control system to assist the driver with keeping the vehicle on the intended path. It is not a substitute for safe driving practices. Always adjust your speed and driving to the road conditions.

### **WARNING**

Never drive too fast for the road conditions when cornering. ESC will not prevent accidents.

Excessive speed in turns, abrupt maneuvers, and hydroplaning on wet surfaces can result in severe accidents.

### **ESC operation**

#### **ESC ON condition**

When the Start/Stop button is in the ON position, ESC and the ESC OFF indicator lights illuminate for about 3 seconds. After both lights go off, ESC is enabled.

### **When operating**



When ESC is in operation, the ESC indicator light blinks:

- When you apply your brakes under conditions which may lock the wheels, you may hear sounds from the brakes, or feel a corresponding sensation in the brake pedal. This is normal and it means your ESC is active.
- When ESC activates, the vehicle may not respond to the accelerator as it does under routine conditions.
- If Smart Cruise Control was in use when ESC activates, Smart Cruise Control automatically disengages. Smart Cruise Control can be reengaged when the road conditions allow. For more information, refer to the "Smart Cruise Control (SCC)" section in chapter 7.

### **ESC OFF condition**



To cancel ESC operation:

- State 1  
Press the ESC OFF button briefly. The ESC OFF indicator light and/or message **'Traction Control disabled'** will illuminate. In this state, the traction control function of ESC (electric vehicle control management) is disabled, but the brake control function of ESC (braking management) still operates.

- State 2

Press and hold the ESC OFF button continuously for more than 3 seconds. The ESC OFF indicator light and/or message **'Traction & Stability Control disabled'** illuminates and a warning chime sounds. In this state, both the traction control function of ESC (electric vehicle control management) and the brake control function of ESC (braking management) are disabled.

If the Start/Stop button is pressed to the OFF position when ESC is off, ESC remains off. Upon restarting the vehicle, ESC will automatically turn on again.

When ESC (electric vehicle control) is deactivated, the vehicle will lose the traction and stability if the vehicle is driven by abrupt steering wheel control. It is possible that the tire may make a collision with the connected parts of the tire. Do not turn off ESC while driving the vehicle for your safety.

### Indicator lights

ESC indicator light (blinks)



ESC OFF indicator light (comes on)



When the Start/Stop button is pressed to the ON position, the ESC indicator light illuminates, then goes off if the ESC system is operating normally.

The ESC indicator light blinks whenever ESC is operating.

If the ESC indicator light stays on, your vehicle may have a malfunction with the ESC system. When this warning light illuminates, have the vehicle inspected by an authorized HYUNDAI dealer as soon as possible.

The ESC OFF indicator light comes on when ESC is turned off.

### WARNING

When ESC is blinking, this indicates ESC is active:

Drive slowly and NEVER attempt to accelerate. NEVER turn ESC off while the ESC indicator light is blinking or you may lose control of the vehicle resulting in an accident.

### NOTICE

Driving with wheels and tires with different sizes may cause the ESC system to malfunction. Before replacing tires, make sure all four tires and wheels are the same size. Never drive the vehicle with different sized wheels and tires installed.

## ESC OFF usage

### When Driving

The ESC OFF mode should only be used briefly to help free the vehicle if stuck in snow or mud, by temporarily stopping operation of ESC, to maintain wheel torque.

To turn ESC off while driving, press the ESC OFF button while driving on a flat road surface.

### NOTICE

To prevent damage to the gear:

- Do not allow wheel(s) of one axle to spin excessively while the ESC, ABS, and Parking Brake warning lights are displayed. The repairs would not be covered by the vehicle warranty. Reduce motor power and do not spin the wheel(s) excessively while these lights are displayed.
- When operating the vehicle on a dynamometer, make sure ESC is turned off (ESC OFF light illuminated).

### *i* Information

- Turning ESC off does not affect ABS or standard brake system operation.
- Select 0 step of the regenerative braking system and depress the brake pedal around 10 times to efficiently apply brake disc cleaning.

Brake disc cleaning may decrease the driving distance by restraining the regenerative braking system. After brake disc cleaning, the regenerative braking system may be restored.

If the regenerative braking system is not restored after the brake disc cleaning, have the vehicle inspected by an authorized HYUNDAI dealer.

## Vehicle Stability Management (VSM)

Vehicle Stability Management is a function of the Electronic Stability Control (ESC) system. It helps the vehicle stay stable when accelerating or braking suddenly on wet, slippery and rough roads where traction over the four tires can suddenly become uneven.

### WARNING

Take the following precautions when using Vehicle Stability Management:

- ALWAYS check the speed and the distance to the vehicle ahead. VSM is not a substitute for safe driving practices.
- Never drive too fast for the road conditions. VSM will not prevent accidents. Excessive speed in bad weather, on slippery and uneven roads can result in severe accidents.

## VSM operation

### When operating

When you apply your brakes under conditions which may activate ESC, you may hear sounds from the brakes, or feel a corresponding sensation in the brake pedal. This is normal and it means your VSM is active.

### *i* Information

VSM does not operate when:

- Driving on a banked road such as gradient or incline.
- Driving in reverse.
- The ESC OFF indicator light is on.
- The MDPS (Motor Driven Power Steering) warning light () is on or blinks.

**VSM OFF condition**

To cancel VSM operation, press the ESC OFF button. ESC OFF (🚫) indicator light will illuminate.

To turn on VSM, press the ESC OFF button again. The ESC OFF indicator light will go out.

**⚠️ WARNING**

If the ESC (🚫) indicator light or MDPS (🚫) warning light stays illuminated or blinks, your vehicle may have a malfunction with the VSM system. When the warning light illuminates have the vehicle inspected by an authorized HYUNDAI dealer as soon as possible.

**NOTICE**

Driving with wheels and tires with different sizes may cause the VSM system to malfunction. Before replacing tires, make sure all four tires and wheels are the same size. Never drive the vehicle with different sized tires and wheels installed.

**Hill-Start Assist Control (HAC)**

Hill-Start Assist Control helps prevent the vehicle from rolling backwards when starting a vehicle from a stop on a hill. The system operates the brakes automatically for about 2 seconds (maximum of 5 seconds when the accelerator pedal is slightly depressed during HAC operation) and releases the brake after 2 seconds or when the accelerator pedal is depressed.

**⚠️ WARNING**

Always be ready to depress the accelerator pedal when starting off an incline. Hill-Start Assist Control activates only for about 2 seconds (maximum of 5 seconds when the accelerator pedal is slightly depressed during HAC operation).

**i Information**

- Hill-Start Assist Control does not operate when the gear is shifted to P (Park) or N (Neutral).
- Hill-Start Assist Control activates even when the ESC (Electronic Stability Control) is off. However, it does not activate, when ESC does not operate normally.

**Brake Assistant System (BAS)**

The Brake Assistant System provides additional pressure when the brake pedal is momentarily and strongly depressed in a situation sudden braking is required while driving.

The Brake Assistant System reduces the time for ABS(Anti-Lock Brake System) control to enter and consequently reduces the braking distance, by providing additional pressure up to the point of ABS intervention.

**⚠️ WARNING**

The system may not operate depending on driver's driving habit, driving speed, the degree to which the brake pedal is depressed and the road surface condition.

## Good Braking Practices

### **WARNING**

Whenever leaving the vehicle or parking, always come to a complete stop and continue to depress the brake pedal. Shift the gear to the P (Park) position, then apply the parking brake, and press the Start/Stop button to the OFF position.

Vehicles parked with the parking brake not applied or not fully engaged may roll inadvertently and may cause injury to the driver and others. ALWAYS apply the parking brake before exiting the vehicle.

---

Be aware of wet brakes. The brakes may get wet if the vehicle is driven through standing water or if it is washed. Your vehicle will not stop as quickly if the brakes are wet. Wet brakes may cause the vehicle to pull to one side.

To dry the brakes, apply the brakes lightly until the braking action returns to normal. If the braking action does not return to normal, stop as soon as it is safe to do so and call an authorized HYUNDAI dealer for assistance.

DO NOT drive with your foot resting on the brake pedal. Even light, but constant pedal pressure can result in the brakes overheating, brake wear, and possibly even brake failure.

If a tire goes flat while you are driving, apply the brakes gently and keep the vehicle pointed straight ahead while you slow down. When you are moving slowly enough for it to be safe to do so, pull off the road and stop in a safe location.

Keep your foot firmly on the brake pedal when the vehicle is stopped to prevent the vehicle from rolling forward.



## All Wheel Drive (AWD)

 if equipped

When All Wheel Drive (AWD) is activated, driving forces are distributed appropriately to front and rear wheels. It could improve driving performance by maximizing the driving force of vehicles on severe road conditions such as steep hills, unpaved, slippery, etc.

Advantage of electronic AWD

1. Improvement of straight stability
2. Improvement of driving performance on curve
3. Secure stability on severe condition such as wet and sandy roads.
4. Improvement of energy efficiency from driving mode automatic control.

### Information

AWD vehicles could change the engagement status of the motor according to the situation required. Auto changing the driving mode (2WD/AWD) helps improve energy efficiency and driving stability.

### WARNING

To reduce the risk of SERIOUS INJURY or DEATH:

- Avoid high speeds when cornering or turning.
- Do not make quick steering wheel movements, such as sharp lane changes or fast, sharp turns.
- The risk of a rollover is greatly increased if you lose control of your vehicle at highway speeds.
- Loss of control often occurs if two or more wheels drop off the roadway and the driver over steers to reenter the roadway.

- In the event your vehicle leaves the roadway, do not steer sharply. Instead, slow down before pulling back into the travel lanes.

### NOTICE

- Do not drive in water if the level is higher than the bottom of the vehicle.
- Check your brake condition once you are out of mud or water. Depress the brake pedal several times as you move slowly until you feel normal braking return.
- Shorten your scheduled maintenance interval if you drive in off-road conditions such as sand, mud or water (For more information, refer to the "Maintenance Under Severe Usage and Low Mileage Conditions" section in chapter 9.)
- Always wash your vehicle thoroughly after off road use, especially the bottom of the vehicle.
- Be sure to equip the vehicle with four tires of the same size and type.
- Make sure that a full time AWD vehicle is towed by a flat bed tow truck.

### *For safe AWD operation*

#### **Before driving**

- Make sure all passengers are wearing seat belts.
- Sit upright and closer to the steering wheel than usual. Adjust the steering wheel to a position comfortable for you to drive.

### Driving on snow-covered or icy roads

- Start off slowly by applying the accelerator pedal gently.
- Use snow tires or tire chains.
- Keep sufficient distance between your vehicle and the vehicle in front of you.
- Using regenerative braking helps the steering on the downhill. However, it may be difficult to adjust the vehicle while coasting using regenerative braking, so avoid using the third level of regenerative braking as much as possible.
- Avoid speeding, rapid acceleration, sudden brake applications, and sharp turns to prevent skids.
- It is difficult to start again if the vehicle stops on an uphill road. Keep your distance from other vehicles and drive slowly.

### **i** Information

When using Snow Tires, mount them on all four wheels.

When using tire chains, install them on the rear tires.

However, driving speed must be below 18 mph (30 km/h) and minimize the driving distance. High-speed or long-term driving with tire chains installed may malfunction or damage the AWD system.

For more information on Snow Tires and Tire Chains, refer to the "Winter Driving" section later in this chapter.

---

### Driving in sand or mud

- Maintain slow and constant speed.
- Use tire chains driving in mud if necessary.
- Keep sufficient distance between your vehicle and the vehicle in front of you.
- Reduce vehicle speed and always check the road condition.

- Avoid speeding, rapid acceleration, sudden brake applications, and sharp turns to prevent getting stuck.

### **NOTICE**

When the vehicle is stuck in snow, sand or mud, place a nonslip material under the drive wheels to provide traction OR slowly spin the wheels in forward and reverse directions which causes a rocking motion that may free the vehicle.

---

### Driving up or down hills

- Driving uphill
  - Before starting off, check if it is possible to drive uphill.
  - Drive as straight as possible.
- Driving downhill
  - Do not change gear while driving downhill. Select gear before driving downhill.
  - Drive straight as possible.

### **! WARNING**

Exercise extreme caution driving up or down steep hills. The vehicle may flip over depending on the grade, terrain, water and mud conditions.

---

### **! WARNING**

Do not drive across the contour of steep hills. A slight change in the wheel angle can destabilize the vehicle, or a stable vehicle may lose stability if the vehicle stops its forward motion. Your vehicle may roll over and lead to a serious injury or death.

---

### Driving through water

- Try to avoid driving in deep standing water.
- Do not change gear while driving in water.

#### CAUTION

Always drive slowly in water. If you drive too fast, water may get into the motor compartment, causing your vehicle to suddenly stop.

### Additional driving conditions

- Become familiar with the off-road conditions before driving.
- Always pay attention when driving off-road and avoid dangerous areas.
- Drive slowly when driving in heavy wind.
- Reduce vehicle speed when cornering. The center of gravity of AWD vehicles is higher than conventional 2WD vehicles, making them more likely to roll over when you rapidly turn corners.
- Always hold the steering wheel firmly when you are driving off-road.

#### WARNING

Do not grab the inside of the steering wheel when you are driving off-road. You may hurt your arm by a sudden steering maneuver or from steering wheel rebound due to an impact with objects on the ground. You could lose control of the steering wheel which may lead to serious injury or death.

## Emergency Precautions

### Tires

When replacing tires, be sure to equip all four tires with the same size, type, tread patterns, brand and load-carrying capacity.

#### WARNING

Do not use tire and wheel with different size and type from the one originally installed on your vehicle. It can affect the safety and performance of your vehicle, which could lead to steering failure or rollover causing serious injury.

#### WARNING

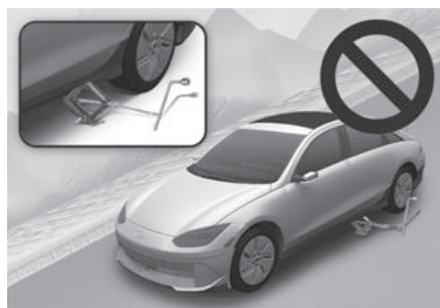

Never start or run the vehicle while an AWD vehicle is raised on a jack. The vehicle can slip or roll off of a jack causing serious injury or death to you or those nearby.

### Towing

AWD vehicles must be towed with a wheel lift and dollies or flatbed equipment with all the wheels off the ground. For more information, refer to the "Towing" section in chapter 8.

### Vehicle inspection

- If the vehicle needs to be operated on a vehicle lift do not attempt to stop any of the four wheels from turning. This could damage the AWD system.
- Never engage the parking brake while running the vehicle on a car lift. This may damage the AWD system.

### Dynamometer testing

An AWD vehicle must be tested on a special four wheel chassis dynamometer.

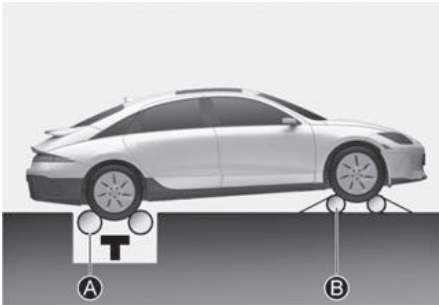

[A] Roll tester (Speedometer)  
[B] Temporary free roller

An AWD vehicle should not be tested on a 2WD roll tester. If a 2WD roll tester must be used, perform the following procedure:

1. Check the tire pressures recommended for your vehicle.
2. Place the rear wheels on the roll tester for a speedometer test as shown in the illustration.
3. Release the parking brake.
4. Place the front wheels on the temporary free roller as shown in the illustration.

### WARNING

Keep away from the front of the vehicle while the vehicle is in gear on the dynamometer. The vehicle can jump forward and cause serious injury or death.

## Drive Mode Integrated Control System (2WD)

 If equipped

### Drive Mode



Drive mode may be selected according to the driver's preference or road condition.



The mode changes whenever the driver pushes the DRIVE MODE button.

### **NORMAL mode**

Normal mode is a driving mode used when driving on general roads, city center and highways.

### **ECO mode**

ECO mode is a driving mode improving energy efficiency by controlling motors and gear.

Electric energy efficiency varies according to the driver's driving habit and road condition.

- When ECO mode is selected, the ECO indicator illuminates on the instrument cluster and the color of the mood lamp is changed.
- When ECO mode is activated:
  - The acceleration response may be slightly reduced if the accelerator pedal is depressed moderately.
  - The air conditioner performance may be limited.

The above situations are normal conditions when ECO mode is activated to help improve electric energy efficiency.

#### Limitations of ECO mode

If the following conditions occur while ECO mode is operating, the system operation is limited even though there is no change in the ECO indicator.

- When coolant temperature is low:  
The system will be limited until motor performance becomes normal.
- When driving up a hill:  
The system will be limited to gain power when driving uphill because motor torque is restricted.

#### SPORT mode

SPORT mode is a driving mode improving driving performance by controlling motors and gear.

In SPORT mode, the electric energy efficiency may decrease.

- When SPORT mode is selected, the SPORT indicator illuminates on the instrument cluster and the color of the mood lamp is changed.
- Whenever the vehicle is restarted, the drive mode reverts back to NORMAL mode. If SPORT mode is desired, re-select SPORT mode.

#### SNOW mode

SNOW mode provides safe driving on the snowy roads.

- Press and hold the drive mode button to select SNOW mode.
- When SNOW mode is selected, the SNOW indicator will illuminate on the instrument cluster and the color of the mood lamp will change.

#### NOTICE

- Depress the accelerator pedal softly on the snow and the ice.
- Keep the distance from the vehicle in the front.
- Prevent rapid acceleration, deceleration and steering control. Abrupt driving on the snow may cause the accident.

#### MY DRIVE MODE

In MY DRIVE MODE, you can adjust the vehicle performance for each function. To set MY DRIVE MODE, go to **Setup > Vehicle > Drive mode > CUSTOM > MY DRIVE MODE** in the infotainment system.

	MY DRIVE MODE
Power output	Maximized/Normal/Minimized
Acceleration sensitivity	High/Moderate/Low
Steering	NORMAL/SPORT

Press and hold the drive mode button to select MY DRIVE MODE. The MY DRIVE MODE indicator will illuminate on the instrument cluster.

- If the controller is replaced or the controller software is updated, the setting of MY DRIVE MODE may be initialized.

## Drive mode Integrated Control System (AWD)

 If equipped

### Drive Mode



Drive mode may be selected according to the driver's preference or road condition.

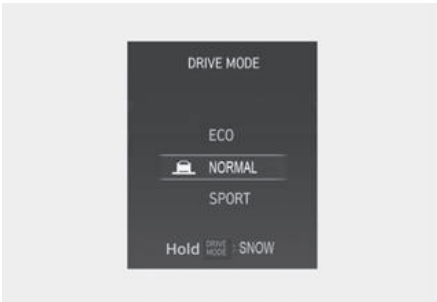

The mode changes whenever the driver pushes the DRIVE mode button.

### **NORMAL mode**

Normal mode is a driving that provides comfortable driving with normal motor response. The vehicle is driven mainly with the rear wheels (2WD), and automatically converts to AWD according to the road and driving conditions.

### **ECO mode**

ECO mode is a driving mode vehicles could change the engagement status of the motor according to the situation required. Auto changing the driving mode(2WD/AWD)helps improve energy efficiency.

Electric energy efficiency varies according to the driver's driving habit and road condition.

- When ECO mode is selected, the ECO indicator illuminates on the instrument cluster and the color of the mood lamp is changed.
- When ECO mode is activated:
  - The acceleration response may be slightly reduced if the accelerator pedal is depressed moderately.
  - The air conditioner performance may be limited.
  - The shift pattern of the gear may change.

The above situations are normal conditions when ECO mode is activated to help improve electric energy efficiency.

### **Limitations of ECO mode**

If the following conditions occur while ECO mode is operating, the system operation is limited even though there is no change in the ECO indicator.

- When coolant temperature is low:  
The system will be limited until motor performance becomes normal.
- When driving up a hill:  
The system will be limited to gain power when driving uphill because motor torque is restricted.

### **SPORT mode**

SPORT mode is a driving mode improving driving performance by fixing AWD system and controlling gear.

In SPORT mode, the electric energy efficiency may decrease.

- When SPORT mode is selected, the SPORT indicator illuminates on the instrument cluster and the color of the mood lamp is changed.
- Whenever the vehicle is restarted, the drive mode reverts back to NORMAL mode. If SPORT mode is desired, re-select SPORT mode.

### **SNOW mode**

SNOW mode is a driving mode improving driving performance by changing the engagement status of the motor according to the situation required. Auto changing the driving mode(2WD/AWD)helps improve driving stability.

- Press and hold the drive mode button to select SNOW mode.
- When SNOW mode is selected, the SNOW indicator will illuminate on the instrument cluster and the color of the mood lamp will change.
- When SNOW mode is activated, the driving power is distributed to four wheels automatically, increasing the stability of the vehicle.

### **NOTICE**

- Depress the accelerator pedal softly on the snow and the ice.
- Keep the distance from the vehicle in the front.
- Prevent rapid acceleration, deceleration and steering control. Abrupt driving on the snow may cause the accident.

### **MY DRIVE MODE**

In MY DRIVE MODE, you can adjust the vehicle performance for each function. To set MY DRIVE MODE, go to **Setup > Vehicle > Drive mode > CUSTOM > MY DRIVE MODE** in the infotainment system.

	<b>MY DRIVE MODE</b>
Power output	Maximized/Normal/ Minimized
Acceleration sensitivity	High/Moderate/Low
Steering	NORMAL/SPORT
Driveline	AWD/AUTO AWD/2WD

Press and hold the drive mode button to select MY DRIVE MODE. The MY DRIVE MODE indicator will illuminate on the instrument cluster.

- When driving in 2WD, AWD will operate under following conditions:
  - Driving at low speed or stopping
  - Driving on an uphill or slippery road
  - Malfunction of the rear-wheel motor
- If the controller is replaced or the controller software is updated, the setting of MY DRIVE MODE may be initialized.

## Drive Modes Characteristic

The characteristic of each components varies depending on which drive mode is selected.

Drive Mode	SNOW	NORMAL	ECO	SPORT
Characteristics	Snow driving	Normal driving mode	High electric energy efficiency mode	Sporty driving mode
Button activation	Press more than 1 sec.	Press	Press	Press
Indicator on the cluster	SNOW	NORMAL	ECO	SPORT
Climate system control	NORMAL	NORMAL	ECO(ECO/NORMAL) *1	NORMAL
Speed Limit	-	-	-	-
Regenerative braking level	0-1	0-3		
Brake mode	NORMAL	NORMAL/SPORT *1	NORMAL	NORMAL/SPORT *1

\*1 It is possible to set the driving condition for each drive mode, at the drive mode setting in Infotainment system.

### **i** Information

The infotainment system may change after software updates. For more information, refer to the user's manual provided in the infotainment system and the quick reference guide.



## Active Air Flap



Active air flap system controls the air flap below the front bumper to cool the vehicle parts and improve energy efficiency.

### *i* Information

Active air flap system could be activate regardless of the vehicle condition. (Parking, driving, charging, etc.)

## Malfunction

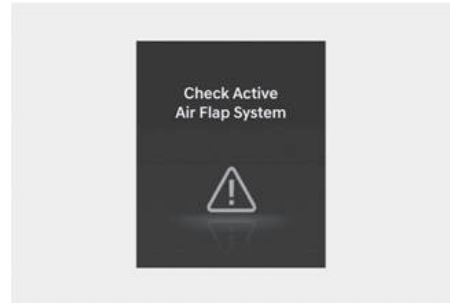

The active air flap system may not operate normally if the air flap is temporarily opened due to foreign factors or if the controller is contaminated by snow or rain, etc.

When "**Check the active air flap system**" is popped up on cluster display, stop the vehicle in a safe place and check the status of the air flap.

Start the vehicle after performing the necessary work like foreign matter removal and waiting 10 minutes. If the pop-up remains up, contact an authorized HYUNDAI dealer.

### CAUTION

- Regardless of the pop-up, if the air flaps aren't in the same position, stop the vehicle and wait for 10 minutes and start the vehicle and inspect the air flap.
- The active air flap system is actuated by motors. Do not disturb actuation or apply force excessively. It may cause failure.

## Active sound design

 if equipped

- Active Sound Design provides various virtual driving sounds based on the driving mode, vehicle speed, and accelerator pedal. You can adjust the volume and change the settings for acceleration pedal response and sound style.
- To change the volume of the Active Sound Design in the infotainment system, select: **Setup > Vehicle > Active Sound Design**, or **Setup > Sound > Active Sound Design**.
- The volume of the Active Sound Design is adjusted according to the drive mode (Eco, Normal, Sport) selected.
- Any unauthorized replacement of the vehicle's speaker and amplifier may cause Active Sound Design to malfunction.

### Information

The infotainment system may change after software updates. For more information, refer to the user's manual provided in the infotainment system and the quick reference guide.

---

## Special Driving Conditions

### Hazardous Driving Conditions

When hazardous driving elements are encountered such as water, snow, ice, mud and sand, take the following precautions:

- Drive cautiously and maintain a longer braking distance.
- Avoid abrupt braking or steering.
- When your vehicle is stuck in snow, mud, or sand, accelerate slowly to avoid unnecessary wheel spin.
- Put sand, rock salt, tire chains or other non-slip materials under the wheels to provide additional traction while the vehicle becomes stuck in ice, snow, or mud.

### WARNING

Changing the tire speed suddenly could cause the tires to skid while driving on slippery surface. Be careful when driving on slippery surfaces.

---

### Rocking the Vehicle

If it is necessary to rock the vehicle to free it from snow, sand, or mud, first turn the steering wheel right and left to clear the area around your front wheels. Then, shift back and forth between R (Reverse) and a forward gear.

Try to avoid spinning the wheels, and do not race the vehicle.

To prevent gear wear, wait until the wheels stop spinning before shifting gears. Release the accelerator pedal while shifting, and press lightly on the accelerator pedal while the vehicle is in gear. Slowly spinning the wheels in forward and reverse directions causes a rocking motion that may free the vehicle.

## WARNING

Always turn off the ESC system before rocking the vehicle. If the vehicle is stuck and excessive wheel spin occurs, the temperature in the tires may increase very quickly. If the tires become damaged, a tire blow out or tire explosion may occur - you and others may be injured. Do not attempt this procedure if people or objects are near the vehicle.

If you attempt to free the vehicle, the vehicle may overheat quickly, possibly causing a motor compartment fire or other damage. Try to avoid spinning the wheels as much as possible to prevent overheating of the tires or the motor. DO NOT allow the vehicle to spin the wheels above 35 mph (56 km/h).

If you are still stuck after rocking the vehicle a few times, have the vehicle pulled out by a tow vehicle to avoid motor overheating, possible damage to the transmission, and tire damage. Refer to the “Towing” section in chapter 8.

## Smooth Cornering

Avoid braking or gear changing in corners, especially when roads are wet. Ideally, cornering should be taken under gentle acceleration.

## Driving at Night

Night driving presents more hazards than driving in the daylight. Here are some important tips to remember:

- Slow down and keep more distance between you and other vehicles, as it may be more difficult to see at night, especially in areas where there may not be any street lights.
- Adjust your mirrors to reduce the glare from other drivers' headlights.

- Keep your headlights clean and properly aimed. Dirty or improperly aimed headlights will make it much more difficult to see at night.
- Avoid staring directly at the headlights of oncoming vehicles. You could be temporarily blinded, and it will take several seconds for your eyes to readjust to the darkness.

## Driving in the Rain

Rain and wet roads can make driving dangerous. When driving in the rain or on slick pavement:

- Slow down and allow extra following distance. A heavy rainfall makes it harder to see and increases the distance needed to stop your vehicle.
- Turn OFF your Smart Cruise Control.
- Replace your windshield wiper blades when they show signs of streaking or missing areas on the windshield.
- Make sure your tires have enough tread. If your tires do not have enough tread, making a quick stop on wet pavement may cause a skid and possibly lead to a collision. Refer to the “Tire Replacement” section in Chapter 9.
- Turn on your headlights to make it easier for others to see you. Using your headlights when using your windshield wipers is required in some jurisdictions.
- Driving too fast through large puddles may affect your brakes. If you must go through puddles, try to drive through them slowly.
- If you believe your brakes are wet, apply them several times while the vehicle is moving slowly.

## Hydroplaning

If the road is wet enough and you are going fast enough, your vehicle may have little or no contact with the road surface and actually ride on the water. The best advice is SLOW DOWN when the road is wet.

The risk of hydroplaning increases as the depth of tire tread decreases. For more information, refer to the “Tire Replacement” section in chapter 9.

## Driving in Flooded Areas

Avoid driving through flooded areas unless you are sure the water is not deeper than the bottom of the wheel hub. If you are not sure, turn around and find a different route. Drive through any water slowly. Allow adequate stopping distance because the brake performance can be reduced.

After driving through water, dry the brakes by gently applying them several times while the vehicle is moving slowly.

## Highway Driving

### **Tires**

Adjust the tire inflation pressure, as specified. Under-inflation may overheat or damage the tires.

Do not install worn-out or damaged tires, which may reduce traction or fail.

### ***i* Information**

Never over-inflate your tires above the maximum inflation pressure, as specified on your tires.

---

### **Coolant and high voltage battery**

Driving at higher speeds on the highway consumes more electric energy and is less efficient than driving at a slower, more moderate speed. Maintain a moderate speed in order to conserve electric energy when driving on the highway.

Be sure to check both the coolant level and the electric energy level before driving.

## Winter Driving

The severe weather conditions of winter quickly wear out tires and cause other problems. To minimize winter driving problems, you should take the following suggestions:

### Snow or Icy Conditions

You need to keep sufficient distance between your vehicle and the vehicle in front of you.

Apply the brakes gently. Speeding, rapid acceleration, sudden brake applications, and sharp turns are potentially very hazardous practices. Sudden brake applications on snowy or icy roads may cause the vehicle to skid.

To drive your vehicle in deep snow, it may be necessary to install tire chains on your tires.

Always carry emergency equipment. Some of the items you may want to carry include tire chains, tow straps or chains, a flashlight, emergency flares, sand, a shovel, jumper cables, a window scraper, gloves, ground cloth, coveralls, a blanket, etc.

### Snow tires

#### WARNING

Snow tires should be equivalent in size and type to the vehicle's standard tires. Otherwise, the safety and handling of your vehicle may be adversely affected.

If you mount snow tires on your vehicle, make sure to use radial tires of the same size and load range as the original tires. Mount snow tires on all four wheels to balance your vehicle's handling in all weather conditions. The traction provided by snow tires on dry roads may not be as high as your vehicle's original equipment tires. Check with the tire dealer for maximum speed recommendations.

#### Information

Do not install studded tires without first checking local and municipal regulations for possible restrictions against their use.

### Summer tires

- Summer tires are used to maximize the driving performance on dry roads.
- If the temperature is below 45 °F (7 °C) or you are driving on snowy or icy roads, the summer tires lose their brake performance and traction as the tire grip weakens significantly.
- If the temperature is below 45 °F (7 °C) or you are driving on snowy or icy roads, mount snow tires or all-season tires of the same size with your vehicle's standard tire for safe driving. Both snow and all-season tires have M+S markings.
- When using the M+S tires, use tires with the same tread produced by the same manufacturer for safe driving.
- When driving with the M+S tires with the lower maximum allowable speed than that of the vehicle's standard summer tire, be careful not to exceed the speed allowed for the M+S tires.

### **Tire chains (Wire chains)**



Since the sidewalls of radial tires are thinner than other types of tires, they may be damaged by mounting some types of tire chains on them. Therefore, the use of snow tires is recommended instead of tire chains. If tire chains must be used, use genuine Hyundai parts and install the tire chain after reviewing the instructions provided with the tire chains. Damage to your vehicle caused by improper tire chain use is not covered by your vehicle manufacturer's warranty.

When using tire chains, install tire chains only on the rear tires.

#### **WARNING**

The use of tire chains may adversely affect vehicle handling:

- Drive less than 20 mph (30 km/h) or the chain manufacturer's recommended speed limit, whichever is lower.
- Drive carefully and avoid bumps, holes, sharp turns, and other road hazards, which may cause the vehicle to bounce.
- Avoid sharp turns or locked wheel braking.

#### **i Information**

- Install tire chains only in pairs and on the rear tires. It should be noted that installing tire chains on the tires will provide a greater driving force, but will not prevent side skids.
- Do not install studded tires without first checking local and municipal regulations for possible restrictions against their use.

### **Tire chains (Auto sock)**



Since the sidewalls of radial tires are thinner, they can be damaged by mounting some types of snow chains on them. Therefore, the use of snow tires is recommended instead of snow chains.

Do not mount tire chains on vehicle equipped with aluminum wheels; snow chains may cause damage to the wheels. If snow chains must be used, use AutoSock (fabric snow chain). Damage to your vehicle caused by improper snow chain use is not covered by your vehicle manufacturer's warranty.

When using tire chains, install tire chains only on the rear tires.

## CAUTION

Always check chain installation for proper mounting after driving about 0.3-0.6 mi. (0.5-1 km) to ensure safe mounting. Retighten or remount the chains if they are loose.

### Chain installation

When installing tire chains, follow the manufacturer's instructions and mount them as tightly possible. Drive slowly (less than 20 mph (30 km/h)) with chains installed. If you hear the chains contacting the body or chassis, stop and tighten them. If they still make contact, slow down until the noise stops. Remove the tire chains as soon as you begin driving on cleared roads.

When mounting snow chains, park the vehicle on level ground away from traffic. Turn on the vehicle Hazard Warning Flasher and place a triangular emergency warning device behind the vehicle (if available). Always place the vehicle in P (Park), apply the parking brake and turn off the vehicle before installing snow chains.

## NOTICE

When using tire chains:

- Wrong size chains or improperly installed chains can damage your vehicle's brake lines, suspension, body and wheels.
- Use SAE "S" class or wire chains.
- If you hear noise caused by chains contacting the body, retighten the chain to prevent contact with the vehicle body.
- To prevent body damage, retighten the chains after driving 0.3-0.6 mi. (0.5-1 km).

- Do not use tire chains on vehicles equipped with aluminum wheels. If unavoidable, use a wire type chain.
- Install tire chains that meet the specifications of each tire size to prevent damage your vehicle.
- 18 in. tires use wire chains less than 0.59 in. (15 mm).
- 20 in. tires use AutoSock (fabric snow chain).

## Winter Precautions

### Use high quality ethylene glycol coolant

Your vehicle is delivered with high quality ethylene glycol coolant in the cooling system. It is the only type of coolant that should be used because it helps prevent corrosion in the cooling system, lubricates the water pump, and prevents freezing. Be sure to replace or replenish your coolant in accordance with the "Scheduled Maintenance Services" section in chapter 9.

Before winter, have your coolant tested to make sure that its freezing point is sufficient for the temperatures anticipated during the winter.

### Check battery and cables

Winter temperatures affect battery performance. Inspect the battery and cables, as specified in chapter 9. The battery charging level can be inspected by an authorized HYUNDAI dealer or in a service station.

### To prevent locks from freezing

Spray approved de-icing fluid or glycerin into key holes. When a lock opening is already covered with ice, spray approved de-icing fluid over the ice to remove it. When an internal part of a lock freezes, try to thaw it with a heated key. Carefully use the heated key to avoid an injury.

### **Use approved window washer anti-freeze solution**

Add authorized window washer anti-freeze solution, as specified on the window washer container. Window washer anti-freeze solution is available from an authorized HYUNDAI dealer, and most vehicle accessory outlets. Do not use coolant or other types of anti-freeze solution, to prevent any damage to the vehicle paint.

### **Do not let your parking brake freeze**

Under some conditions, your parking brake may freeze in the engaged position. This is most likely to happen when there is an accumulation of snow or ice around or near the rear brakes or the brakes are wet. When there is the risk that your parking brake may freeze: temporarily apply the parking brake with the gear in P (Park), then block the rear wheels, and then release the parking brake.

### **Do not let ice and snow accumulate underneath**

Under some conditions, snow and ice may build up under the fenders and interfere with the steering. When driving in such conditions during the severe winter, check underneath the vehicle on a regular basis, to make sure that the front wheels and the steering components are not blocked.

### **Carry emergency equipment**

In accordance with weather conditions, carry appropriate emergency equipment, while driving. Some of the items you may want to carry include tire chains, tow straps or chains, flashlight, emergency flares, sand, shovel, jumper cables, window scraper, gloves, ground cloth, coveralls, blanket, etc.

### **Do not place objects or materials in the motor compartment**

Putting objects or materials in the motor compartment may cause a motor failure. Such damage is not be covered by the manufacturer's warranty.



## Vehicle Load Limit

Two labels on your driver's door sill show how much weight your vehicle was designed to carry: the Tire and Loading Information Label and the Certification Label.

Before loading your vehicle, familiarize yourself with the following terms for determining your vehicle's weight ratings, from the vehicle's specifications and the Certification Label:

### Base Curb Weight

This is the weight of the vehicle including a full tank of fuel and all standard equipment. It does not include passengers, cargo, or optional equipment.

### Vehicle Curb Weight

This is the weight of your new vehicle when you picked it up from your dealer plus any aftermarket equipment.

### Cargo Weight

This figure includes all weight added to the Base Curb Weight, including cargo and optional equipment.

### GAW (Gross Axle Weight)

This is the total weight placed on each axle (front and rear) - including vehicle curb weight and all payload.

### GAWR (Gross Axle Weight Rating)

This is the maximum allowable weight that can be carried by a single axle (front or rear). These numbers are shown on the Certification Label. The total load on each axle must never exceed its GAWR.

### GVW (Gross Vehicle Weight)

This is the Base Curb Weight plus actual Cargo Weight plus passengers.

### GVWR (Gross Vehicle Weight Rating)

This is the maximum allowable weight of the fully loaded vehicle (including all options, equipment, passengers and cargo). The GVWR is shown on the Certification Label located on the driver's door sill.

## The Loading Information Label

Type A

TIRE AND LOADING INFORMATION RENSEIGNEMENTS SUR LES PNEUS ET LE CHARGEMENT				
SEATING CAPACITY NOMBRE DE PLACES		TOTAL 5	FRONT AVANT 2	REAR ARRIÈRE 3
The combined weight of occupants and cargo should never exceed 390 kg or 860 lb. Le poids total des occupants et du chargement ne doit jamais dépasser 390 kg ou 860 lb.				
TIRE PNEU	SIZE DIMENSIONS	COLD TIRE PRESSURE PRESSION DES PNEUS À FROID		SEE OWNER'S MANUAL FOR ADDITIONAL INFORMATION VOIR LE MANUEL DE L'USAGER POUR PLUS DE RENSEIGNEMENTS
FRONT AVANT	225/55R18	260kPa, 38psi		
REAR ARRIÈRE	225/55R18	260kPa, 38psi		
SPARE DE SECOURS	NONE AUCUN			

Type B

TIRE AND LOADING INFORMATION RENSEIGNEMENTS SUR LES PNEUS ET LE CHARGEMENT				
SEATING CAPACITY NOMBRE DE PLACES		TOTAL 5	FRONT AVANT 2	REAR ARRIÈRE 3
The combined weight of occupants and cargo should never exceed 390 kg or 860 lb. Le poids total des occupants et du chargement ne doit jamais dépasser 390 kg ou 860 lb.				
TIRE PNEU	SIZE DIMENSIONS	COLD TIRE PRESSURE PRESSION DES PNEUS À FROID		SEE OWNER'S MANUAL FOR ADDITIONAL INFORMATION VOIR LE MANUEL DE L'USAGER POUR PLUS DE RENSEIGNEMENTS
FRONT AVANT	245/40R20	250kPa, 36psi		
REAR ARRIÈRE	245/40R20	255kPa, 37psi		
SPARE DE SECOURS	NONE AUCUN			

Type C

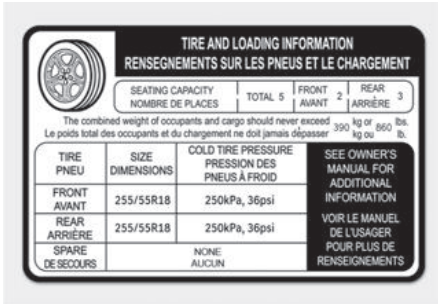

**Vehicle capacity weight**

5 persons: 860 lbs. (390 kg)

Vehicle capacity weight is the maximum combined weight of occupants and cargo. If your vehicle is equipped with a trailer, the combined weight includes the tongue load.

**Seating capacity**

Total : 5 persons (Front seat : 2 persons, Rear seat : 3 persons)

Seating capacity is the maximum number of occupants including a driver, your vehicle may carry. However, the seating capacity may be reduced based upon the weight of all of the occupants, and the weight of the cargo being carried or towed. Do not overload the vehicle as there is a limit to the total weight, or load limit including occupants and cargo, the vehicle can carry.

**Cargo capacity**









The cargo capacity of your vehicle will increase or decrease depending on the weight and the number of occupants and the tongue load, if your vehicle is equipped with a trailer.

**Steps for determining correct load limit**

1. Locate the statement "The combined weight of occupants and cargo should never exceed XXX kg or XXX lbs." on your vehicle's placard.
2. Determine the combined weight of the driver and passengers that will be riding in your vehicle.
3. Subtract the combined weight of the driver and passengers from XXX kg or XXX lbs.
4. The resulting figure equals the available amount of cargo and luggage load capacity. For example, if the "XXX" amount equals 1400 lbs. and there will be five 150 lbs. passengers in your vehicle, the amount of available cargo and luggage load capacity is 650 lbs. (1400 - 750 (5 x 150) = 650 lbs.)
5. Determine the combined weight of luggage and cargo being loaded on the vehicle. That weight may not safely exceed the available cargo and luggage load capacity calculated in Step 4.
6. If your vehicle will be towing a trailer, load from your trailer will be transferred to your vehicle. Consult this manual to determine how this reduces the available cargo and luggage load capacity of your vehicle.

 **WARNING**

Do not overload the vehicle as there is a limit to the total weight, or load limit, including occupants and cargo, the vehicle can carry. Overloading can shorten the life of the vehicle. If the GVWR or the GAWR is exceeded, parts on the vehicle can break, and it can change the handling of your vehicle. These could cause you to lose control and result in an accident.

Example 1	 Maximum Load (1400 lbs.) (635 kg)	≥	 Passenger Weight (150 lbs. × 2 = 300 lbs.) (68 kg × 2 = 136 kg)	+	 Cargo Weight (1100 lbs.) (499 kg)
Example 2	 Maximum Load (1400 lbs.) (635 kg)	≥	 Passenger Weight (150 lbs. × 5 = 750 lbs.) (68 kg × 5 = 340 kg)	+	 Cargo Weight (650 lbs.) (295 kg)
Example 3	 Maximum Load (1400 lbs.) (635 kg)	≥	 Passenger Weight (172 lbs. × 5 = 860 lbs.) (78 kg × 5 = 390 kg)	+	 Cargo Weight (540 lbs.) (245 kg)

### Certification label



The certification label is located on the driver's door sill at the center pillar and shows the maximum allowable weight of the fully loaded vehicle. This is called the GVWR (Gross Vehicle Weight Rating). The GVWR includes the weight of the vehicle, all occupants, fuel and cargo.

This label also tells you the maximum weight that can be supported by the front and rear axles, called Gross Axle Weight Rating (GAWR).

The total weight of the vehicle, including all occupants, accessories, cargo, and trailer tongue load must not exceed the Gross Vehicle Weight Rating (GVWR) or the Gross Axle Weight Rating (GAWR). To find out the actual loads on your front and rear axles, you need to go to a weigh station and weigh your vehicle. Be sure to spread out your load equally on both sides of the centerline.

### WARNING

#### Overloading

- Never exceed the GVWR for your vehicle, the GAWR for either the front or rear axle and vehicle capacity weight. Exceeding these ratings can affect your vehicle's handling and braking ability, and cause an accident.
- Do not overload your vehicle. Overloading your vehicle can cause heat buildup in your vehicle's tires and possible tire failure, increased stopping distances and poor vehicle handling—all of which may result in a collision.

### NOTICE

Overloading your vehicle may cause damage. Repairs would not be covered by your warranty. Do not overload your vehicle.

 **WARNING**

If you carry items inside your vehicle (for example, suitcases, tools, packages, or anything else), they are moving as fast as the vehicle. If you have to stop or turn quickly, or if there is a crash, the items will keep going and can cause an injury if they strike the driver or a passenger.

- Put items in the cargo area of your vehicle. Try to spread the weight evenly.
  - Do not stack items, like suitcases, inside the vehicle above the tops of the seats.
  - Do not leave an unsecured child restraint in your vehicle.
  - When you carry something inside the vehicle, secure it.
- 

## Trailer Towing

We do not recommend using this vehicle for trailer towing.



# 7. Driver Assistance System

Driver Assistance System Notice .....	7-4
Forward Collision-Avoidance Assist (FCA) .....	7-4
Forward Collision-Avoidance Assist Settings .....	7-8
Forward Collision-Avoidance Assist Operation .....	7-11
Forward Collision-Avoidance Assist Malfunction and Limitations.....	7-22
Lane Keeping Assist (LKA).....	7-30
Lane Keeping Assist Settings .....	7-30
Lane Keeping Assist Operation .....	7-31
Lane Keeping Assist Malfunction and Limitations .....	7-34
Blind-Spot Collision-Avoidance Assist (BCA) .....	7-36
Blind-Spot Collision-Avoidance Assist settings.....	7-38
Blind-Spot Collision-Avoidance Assist Operation .....	7-39
Blind-Spot Collision-Avoidance Assist Malfunction and Limitations.....	7-42
Safe Exit Warning (SEW) .....	7-46
Safe Exit Warning Settings .....	7-47
Safe Exit Warning Operation .....	7-48
Safe Exit Warning Malfunction and Limitations .....	7-49
Manual Speed Limit Assist (MSLA).....	7-51
Manual Speed Limit Assist Operation .....	7-51
Intelligent Speed Limit Assist (ISLA) .....	7-53
Intelligent Speed Limit Assist Settings.....	7-54
Intelligent Speed Limit Assist Operation.....	7-54
Intelligent Speed Limit Assist Malfunction and Limitations .....	7-56
Driver Attention Warning (DAW) .....	7-59
Driver Attention Warning Settings.....	7-60
Driver Attention Warning Operation.....	7-60
Driver Attention Warning Malfunction and Limitations .....	7-62
Blind-Spot View Monitor (BVM) .....	7-65
Blind-Spot View Monitor Settings .....	7-65
Blind-Spot View Monitor Operation .....	7-66
Blind-Spot View Monitor Malfunction.....	7-66
Smart Cruise Control (SCC) .....	7-67
Smart Cruise Control Settings .....	7-68
Smart Cruise Control Operation .....	7-69
Smart Cruise Control Malfunction and Limitations.....	7-78

Navigation-Based Smart Cruise Control (NSCC).....	7-84
Navigation-based Smart Cruise Control Settings.....	7-84
Navigation-based Smart Cruise Control Operation.....	7-85
Limitations of Navigation-based Smart Cruise Control .....	7-86
Lane Following Assist (LFA).....	7-89
Lane Following Assist Settings .....	7-89
Lane Following Assist Operation .....	7-90
Lane Following Assist Malfunction and Limitations .....	7-92
Highway Driving Assist (HDA).....	7-93
Highway Driving Assist Settings.....	7-94
Highway Driving Assist Operation .....	7-95
Highway Driving Assist Malfunction and Limitations .....	7-102
Rear View Monitor (RVM).....	7-104
Rear View Monitor Settings .....	7-104
Rear View Monitor Operation.....	7-105
Rear View Monitor Malfunction and Limitations .....	7-106
Surround View Monitor (SVM) .....	7-107
Surround View Monitor Settings .....	7-107
Surround View Monitor Operation .....	7-109
Surround View Monitor Malfunction and Limitations .....	7-111
Rear Cross-Traffic Collision-Avoidance Assist (RCCA) .....	7-112
Rear Cross-Traffic Collision-Avoidance Assist Settings .....	7-113
Rear Cross-Traffic Collision-Avoidance Assist Operation .....	7-113
Rear Cross-Traffic Collision-Avoidance Assist Malfunction and Limitations .....	7-117
Forward/Reverse Parking Distance Warning (PDW).....	7-121
Forward/Reverse Parking Distance Warning Settings .....	7-121
Forward/Reverse Parking Distance Warning Operation .....	7-122
Forward/Reverse Parking Distance Warning Malfunction and Limitations.....	7-124
Forward/Side/Reverse Parking Distance Warning (PDW).....	7-126
Parking Distance Warning Settings.....	7-126
Parking Distance Warning Operation .....	7-127
Parking Distance Warning Malfunction and Limitations .....	7-129
Forward/Side/Reverse Parking Collision-Avoidance Assist (PCA).....	7-131
Parking Collision-Avoidance Assist Settings .....	7-132
Parking Collision-Avoidance Assist Operation .....	7-133



# 7. Driver Assistance System

---

Parking Collision-Avoidance Assist Malfunction and Limitations .....	7-135
Remote Smart Parking Assist 2 (RSPA 2) .....	7-139
Remote Smart Parking Assist Settings .....	7-141
Remote Smart Parking Assist Operation .....	7-142
Remote Smart Parking Assist Malfunction and Limitations .....	7-158
Declaration of Conformity .....	7-164
Front Radar .....	7-164
Front Corner Radar (if equipped)/Rear Corner Radar .....	7-165

## Driver Assistance System Notice

Due to the software update, the description of each function of the driver assistance system may differ from the owner's manual.

## Forward Collision-Avoidance Assist (FCA)

### *Basic function*

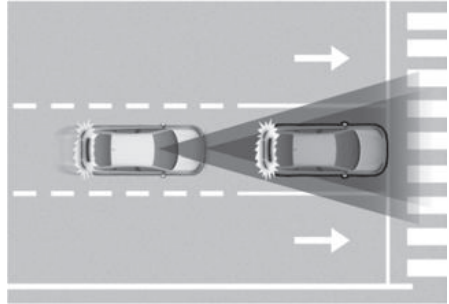

Forward Collision-Avoidance Assist helps detect a vehicle, powered two-wheeler, a pedestrian, or a cyclist ahead on the road and may warn you of a possible collision with a warning message on the instrument cluster and a warning sound. Also, Forward Collision-Avoidance Assist may assist with braking your vehicle to help reduce collision speed or avoid a collision.

In addition, when driving at high speeds, Forward Collision-Avoidance Assist will help detect vehicles in front and adjacent lanes. If a collision is imminent when changing lanes, Forward Collision-Avoidance Assist will apply emergency braking to help prevent a collision. (if equipped)

### ***Junction Turning function***

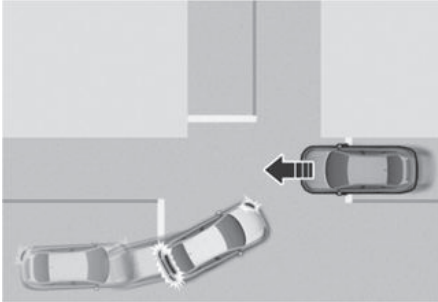

Junction Turning function can help avoid a collision with an oncoming vehicle or powered two-wheeler in an adjacent lane when turning left at a crossroad with the turn signal on by applying emergency braking.

### ***Junction Crossing function***

**+** if equipped

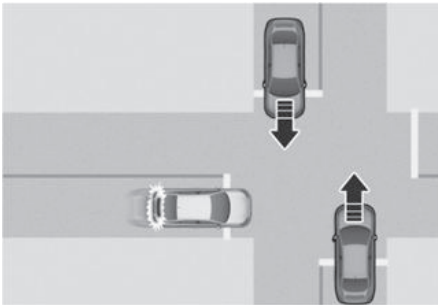

Junction Crossing function can help avoid a collision with oncoming vehicles on the left or right side when crossing an intersection by applying emergency braking.

### ***Direct Oncoming function***

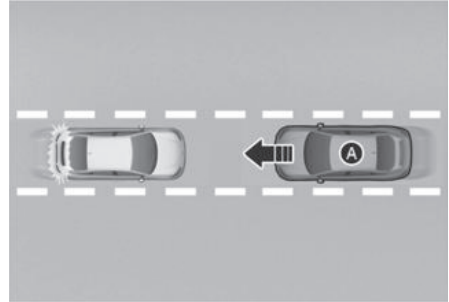

[A] Oncoming vehicle

Direct Oncoming function helps reduce the speed at the collision when a vehicle or powered two-wheeler approaching from the opposite side is detected.

### ***Lane-Change Oncoming function***

**+** if equipped

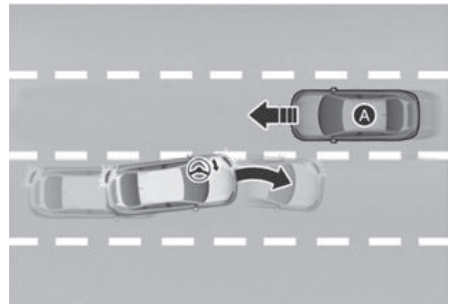

[A] Oncoming vehicle

Lane-Change Oncoming function helps avoid a collision with an oncoming vehicle or powered two-wheeler when changing lanes by assisting the driver's steering.

### Lane-Change Side function

 if equipped

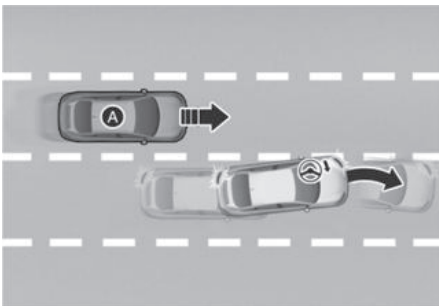
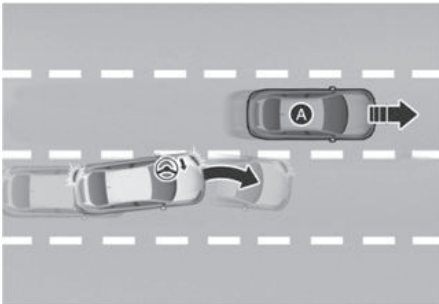

[A] Side vehicle

Lane-Change Side function helps avoid a collision with the vehicle or powered two-wheeler in the next lane when changing lanes by assisting the driver's steering.

### Evasive Steering Assist function

 if equipped

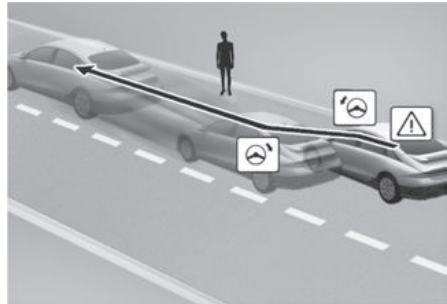

- Driver steering assist  
Evasive Steering Assist function helps avoid a collision with a vehicle, powered two-wheeler, pedestrian or cyclist ahead in the same lane. When a risk of collision is detected, Evasive Steering Assist function will warn the driver and if the driver steers to avoid collision it will assist the driver's steering.
- Evasive steering assist  
Evasive Steering Assist function helps avoid a collision with a powered two-wheeler, pedestrian or cyclist ahead in the same lane. When a risk of collision is detected, Evasive Steering Assist function will warn the driver and if there is space to avoid collision in the lane, it will assist the driver's steering.

*Evasive Steering Assist function operates when there is a collision risk and sufficient operating area between your vehicle and the detected pedestrian or cyclist ahead.*

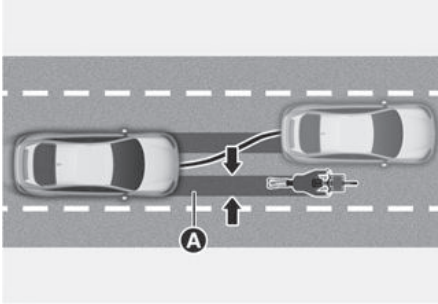

2C\_EvasiveSteeringAssist

[A] Operating Area of Evasive Steering Assist function

### Detecting sensor

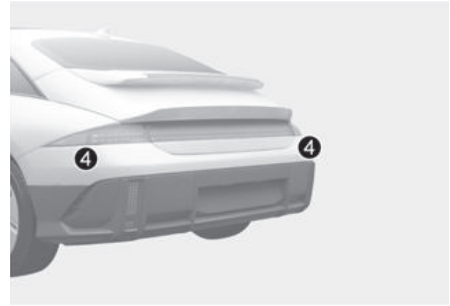

- (1) Front view camera
- (2) Front radar
- (3) Front corner radar (if equipped)
- (4) Rear corner radar (if equipped)

Refer to the picture above for the detailed location of the detecting sensors.

### ⚠ CAUTION

Take the following precautions to maintain optimal performance of the detecting sensor:

- Never disassemble the detecting sensor or sensor assembly, or cause any damage to it.
- If the detecting sensors have been replaced or repaired, have the vehicle inspected by an authorized HYUNDAI dealer.
- Never install any accessories or stickers on the front windshield, or tint the front windshield.
- Exercise extreme caution to keep the front view camera dry.
- Never place any reflective objects (for example, white paper, mirror) over the dashboard.
- Do not place any objects near the front windshield or install any accessories on the front windshield. It can affect the performance of the defogging and defrosting function of the climate control system, which may prevent the Driver Assistance systems from operating.

- Do not apply license plate frame or objects, such as a bumper sticker, film or a bumper guard, near the front radar cover.
- Do not change the position of the license plate. The front radar's detection and control performance may be affected.
- Always keep the front radar and cover clean and free of dirt and debris.  
Use only a soft cloth to wash the vehicle. Do not spray pressurized water directly on the sensor or sensor cover.
- If the radar or around the radar has been damaged or impacted in any way, Forward Collision-Avoidance Assist may not properly operate even though a warning message does not appear on the instrument cluster. Have the vehicle inspected by an authorized HYUNDAI dealer.
- The performance of the front radar cover genuine parts have been proven. Replacing or painting the front radar cover may result in poor performance of Forward Collision-Avoidance Assist. When the parts need to be replaced or modified, make sure to use genuine HYUNDAI parts.
- Vehicles equipped with front corner radar and/or rear corner radar
  - Do not apply license plate frame or objects, such as a bumper sticker, film or a bumper guard, near the front corner radar or rear corner radar.
  - The function may not work properly when the bumper has been replaced, or the surroundings of the front corner radar or rear corner radar has been damaged or paint has been applied.
  - If a trailer, carrier, etc., is installed, it may adversely affect the performance of the rear corner radar or Forward Collision-Avoidance Assist may not operate properly.

## Forward Collision-Avoidance Assist Settings

### Forward Safety

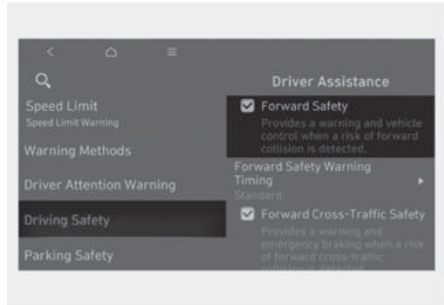

With the vehicle on, select or deselect **Setup > Vehicle > Driver Assistance > Driving Safety > Forward Safety** from the Settings menu to set whether to use each function.

- If **Forward Safety** is selected, Forward Collision-Avoidance Assist will warn the driver with a warning message, an audible warning depending on the collision risk levels. Braking assist will be applied depending on the collision risk levels. If **Forward Safety** is deselected, Forward Safety will turn off. The warning light (⚠️) will illuminate on the instrument cluster.

## Forward Cross-Traffic Safety

**+** if equipped

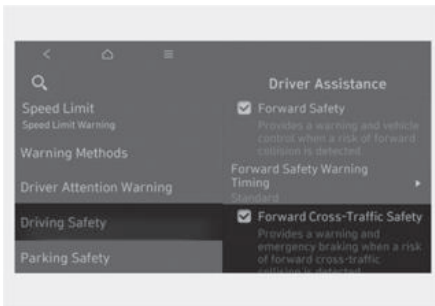

With the vehicle on, select **Setup > Vehicle > Driver Assistance > Driving Safety > Forward Cross-Traffic Safety** from the Settings menu to turn on Junction crossing function and deselect to turn off the function.

## Forward/Side Safety

**+** if equipped

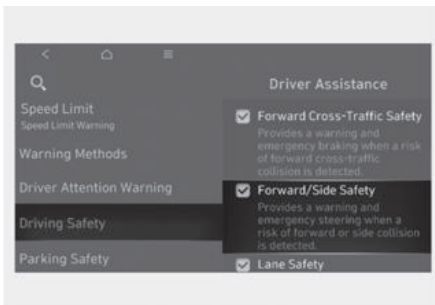

With the vehicle on, select **Setup > Vehicle > Driver Assistance > Driving Safety > Forward/Side Safety** from the Settings menu to turn on Lane-Change Oncoming function, Lane-Change Side function, Evasive Steering Assist function and deselect to turn off the functions.

- If **Forward/Side Safety** is selected, Forward Collision-Avoidance Assist will warn the driver, steering wheel vibration, a warning message, an audible warning depending on the collision risk levels. Steering assist will be applied depending on the collision risk levels. If **Forward/Side Safety** is deselected, Forward/Side Safety will turn off. The warning light (🚨) will illuminate on the instrument cluster.

### ⚠️ WARNING

When the vehicle is restarted, Forward Collision-Avoidance Assist will always turn on. However, at all times, and especially if **Forward Safety** is deselected, the driver should always be aware of the surroundings and drive safely.

### ⚠️ CAUTION

- The setting for Forward Safety include 'Basic function' and 'Junction Turning', and 'Direct Oncoming'.
- The setting for Forward-Cross Traffic Safety includes 'Junction Crossing'.
- The setting for Forward/Side Safety includes 'Lane Change Oncoming', 'Lane-Change Side' and 'Evasive Steering Assist' (if equipped).
- If **Forward Safety** is deselected, Junction Crossing function will not operate even when **Forward Cross-Traffic Safety** and **Forward/Side Safety** is selected. (if equipped)
- Steering wheel vibration can be turned on or off. Select or deselect **Driver Assistance > Warning Methods > Haptic Warning** from the Settings menu.

### Forward Safety Warning Timing

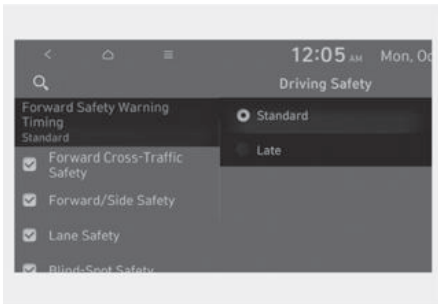

With the vehicle on, select **Setup > Vehicle > Driver Assistance > Driving Safety > Forward Safety Warning Timing** from the Settings menu to change the initial warning activation time for Forward Collision-Avoidance Assist. The warning time can be set to either **Standard** or **Late**.

- Use **Standard** in normal driving conditions. If the Warning Timing seems sensitive, change it to **Late**.
- If **Late** is selected, Forward Collision-Avoidance Assist, warns the driver more slowly.

#### CAUTION

- Even though **Standard** is selected for Warning Timing, if a detected vehicle in front suddenly stops, the warning may seem late.
- Select **Late** for Warning Timing when traffic is light and when driving speed is slow.

#### Information

- If you change the Warning timing, the Warning timing of other Driver assistance systems may change.
- If the vehicle is restarted, Warning timing will maintain the last setting.

### Warning Methods

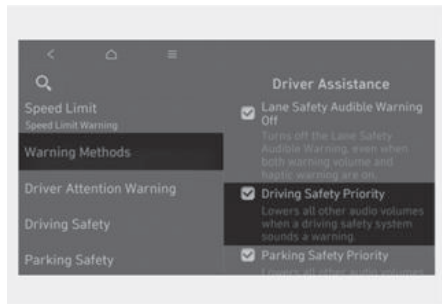
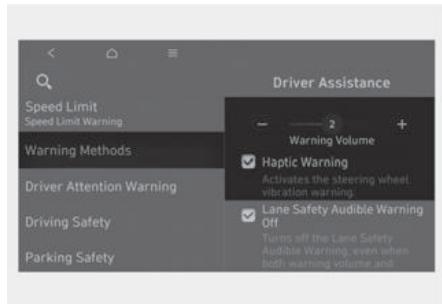

With the vehicle on, go to **Setup > Vehicle > Driver Assistance > Warning Methods** from the Settings in the infotainment system to select the following:

- **Warning Volume:** The Warning Volume can be adjusted.  
If you turn off the **Warning Volume**, for your safety, the function may warn you with a low volume.
- **Haptic Warning:** The steering wheel vibration can be set.
- **Driving Safety Priority:** Your vehicle lowers all other audio volumes when the Driver Assistance system warning sounds.



## *i* Information

- If you change the Warning Methods, Warning Methods of other Driver Assistance systems may change.
- If the vehicle is restarted, Warning Methods will maintain the last setting.
- There may be no Settings menu depending on the feature applied to your vehicle.
- The **Warning Volume** and **Haptic Warning** cannot be turned off at the same time. When one of the warning is turned off, the other is activated.

## Forward Collision-Avoidance Assist Operation

### **Basic function**

The basic function for Forward Collision-Avoidance Assist is to warn and help control the vehicle depending on the collision risk level: 'Collision Warning', 'Emergency Braking' and 'Stopping vehicle and ending brake control'.

### Collision Warning

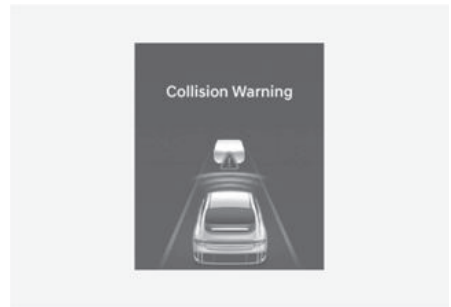

- To warn the driver of a collision, Forward Safety warning light (⚠️) blinking, the **'Collision Warning'** warning message will appear on the instrument cluster, an audible warning will sound and the steering wheel will vibrate.
- If a vehicle or powered two-wheeler is detected in front, the function will operate when your vehicle speed is between about 6-124 mph (10-200 km/h).
- If a pedestrian or cyclist is detected in front, the function will operate when your vehicle speed is between about 6-53 mph (10-85 km/h).

**Emergency Braking**

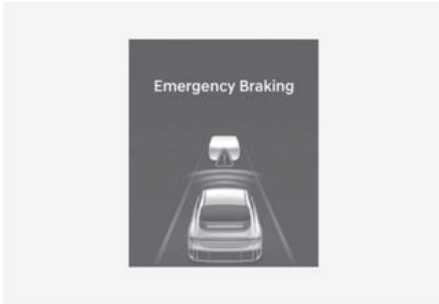

To warn the driver that emergency braking will be assisted, Forward Safety warning light (⚠️) blinking, the **'Emergency Braking'** warning message will appear on the instrument cluster, an audible warning will sound and the steering wheel will vibrate.

Emergency braking will operate under the following conditions:

- Vehicle or powered two-wheeler:

	Driving vehicle	Stopped vehicle
Weak braking power	About 6-124 mph (10-200 km/h)	
Strong braking power	About 6-80 mph (10-130 km/h)	About 6-47 mph (10-75 km/h)*

\*: If Forward Collision Avoidance Assist judges that avoiding a collision is difficult even by changing the driving lane, braking is assisted more earlier.

- Pedestrian or cyclist:

The function will operate when your vehicle speed is between about 6-40 mph (10-65 km/h).

**⚠️ CAUTION**

The function operation range may decrease due to the front traffic condition or the surroundings of the vehicle.

**Stopping vehicle and ending brake control**



- When the vehicle is stopped due to emergency braking, the **'Drive carefully'** warning message will appear on the instrument cluster.

For your safety, the driver should depress the brake pedal immediately and check the surroundings.

- Brake control will end after the vehicle is stopped by emergency braking for about 2 seconds.

**Junction Turning function**

Junction Turning function will warn and help control the vehicle depending on the collision risk level: 'Collision Warning', 'Emergency Braking' and 'Stopping vehicle and ending brake control'

## Collision Warning



- To warn the driver of a collision, Forward Safety warning light (⚠️) blinking, the **'Collision Warning'** warning message will appear on the instrument cluster, an audible warning will sound and the steering wheel will vibrate.
- The function will operate when your vehicle speed is between about 6-19 mph (10-30 km/h) and the oncoming vehicle or powered two-wheeler speed is between about 19-44 mph (30-70 km/h).

## Emergency Braking



- To warn the driver that emergency braking will be assisted, Forward Safety warning light (⚠️) blinking, the **'Emergency Braking'** warning message will appear on the instrument cluster, an audible warning will sound and the steering wheel will vibrate.

- In emergency braking situation, braking is assisted with strong braking power by the function to help prevent collision with the oncoming vehicle.
- The function will operate when your vehicle speed is between about 6-19 mph (10-30 km/h) and the oncoming vehicle or powered two-wheeler speed is between about 19-44 mph (30-70 km/h).

## Stopping vehicle and ending brake control



- When the vehicle is stopped due to emergency braking, the **'Drive carefully'** warning message will appear on the instrument cluster. For your safety, the driver should depress the brake pedal immediately and check the surroundings.
- Brake control will end after the vehicle is stopped by emergency braking for about 2 seconds.

### *i* Information

Press the hazard warning flasher to turn off the audible warning of the collision warning or emergency braking system.

### Junction Crossing function

 if equipped

Junction Crossing function will warn and control the vehicle depending on collision risk level: 'Collision Warning', 'Emergency Braking' and 'Stopping vehicle and ending brake control'

#### Collision Warning



- To warn the driver of a collision, Forward Safety warning light () blinking, the **'Collision Warning'** warning message will appear on the instrument cluster, an audible warning will sound and the steering wheel will vibrate.
- The function will operate when your vehicle speed is between about 6-34 mph (10-55 km/h) and the crossing vehicle speed is between about 6-37 mph (10-60 km/h).

#### Emergency Braking

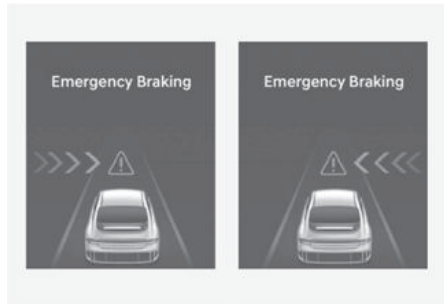

- To warn the driver that emergency braking will be assisted, Forward Safety warning light () blinking, the **'Emergency Braking'** warning message will appear on the instrument cluster, an audible warning will sound and the steering wheel will vibrate.
- In emergency braking situation, braking is assisted with strong braking power by the function to help prevent collision with the crossing vehicle.
- The function will operate when your vehicle speed is between about 6-34 mph (10-55 km/h) and the crossing vehicle speed is between about 6-25 mph (10-40 km/h).

## Stopping vehicle and ending brake control



- When the vehicle is stopped due to emergency braking, the **'Drive carefully'** warning message will appear on the instrument cluster.

For your safety, the driver should depress the brake pedal immediately and check the surroundings.

- Brake control will end after the vehicle is stopped by emergency braking for about 2 seconds.

### CAUTION

If the collision angle with the crossing vehicle is beyond a certain range, Junction Crossing function warning and control may be late or may not operate.

### Information

Press the hazard warning flasher to turn off the audible warning of the collision warning or emergency braking system.

## Direct Oncoming function

Direct Oncoming function will warn and control the vehicle depending on the collision risk level: 'Collision Warning', 'Emergency Braking' and 'Stopping vehicle and ending brake control'.

### Collision Warning



- To warn the driver of a collision, Forward Safety warning light () blinking, the **'Collision Warning'** warning message will appear on the instrument cluster, an audible warning will sound and the steering wheel will vibrate.
- The function will operate when your vehicle speed is between about 19-80 mph (30-130 km/h) and the detected oncoming vehicle speed is about above 6 mph (10 km/h) and the oncoming motorcycle speed is about above 16 mph (25 km/h).

### Emergency Braking

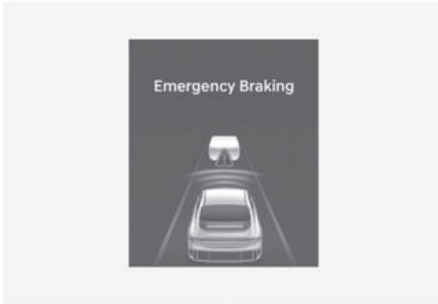

- To warn the driver that emergency braking will be assisted, Forward Safety warning light (⚠️) blinking, the **'Emergency Braking'** warning message will appear on the instrument cluster, an audible warning will sound and the steering wheel will vibrate.
- In emergency braking situation, braking is assisted with strong braking power by the function to help prevent collision with the oncoming vehicle.
- The function will operate when your vehicle speed is between about 19-80 mph (30-130 km/h) and the detected oncoming vehicle speed is about above 6 mph (10 km/h).

### Stopping vehicle and ending brake control



- When the vehicle is stopped due to emergency braking, the **'Drive carefully'** warning message will appear on the instrument cluster. For your safety, the driver should depress the brake pedal immediately and check the surroundings.
- Brake control will end after the vehicle is stopped by emergency braking for about 2 seconds.

#### CAUTION

If your vehicle or the oncoming vehicle is not driving straight, Direct Oncoming function warning and control may be late or may not operate.

#### Information

Press the hazard warning flasher to turn off the audible warning of the collision warning or emergency braking system.

## Lane-Change Oncoming function

**+** if equipped

Lane-Change Oncoming function will warn and control the vehicle depending on collision risk level: 'Collision Warning' and 'Emergency Steering'

### Collision Warning



- To warn the driver of a collision, Emergency Steering warning light (🚗) blinking, the **'Collision Warning'** warning message will appear on the instrument cluster, an audible warning will sound and the steering wheel will vibrate.
- The function will operate when your vehicle speed is between about 25-90 mph (40-145 km/h) and the oncoming vehicle or powered two-wheeler speed is about above 6 mph (10 km/h) and the relative speed with your vehicle is about below 124 mph (200 km/h).

### Emergency Steering

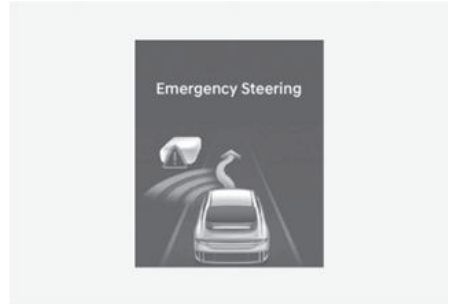

- To warn the driver that emergency steering will be assisted, Emergency Steering warning light (🚗) blinking, the **'Emergency Steering'** warning message will appear on the instrument cluster, an audible warning will sound and the steering wheel will vibrate.
- In emergency steering situation, steering is assisted by the function to help prevent collision with the oncoming vehicle or powered two-wheeler.
- The function will operate when your vehicle speed is between about 25-90 mph (40-145 km/h) and the oncoming vehicle or powered two-wheeler speed is about above 6 mph (10 km/h) and the relative speed with your vehicle is about below 124 mph (200 km/h).

### Lane-Change Side function

 if equipped

Lane-Change Side function will warn and control the vehicle depending on collision risk level: 'Collision Warning' and 'Emergency Steering'

#### Collision Warning

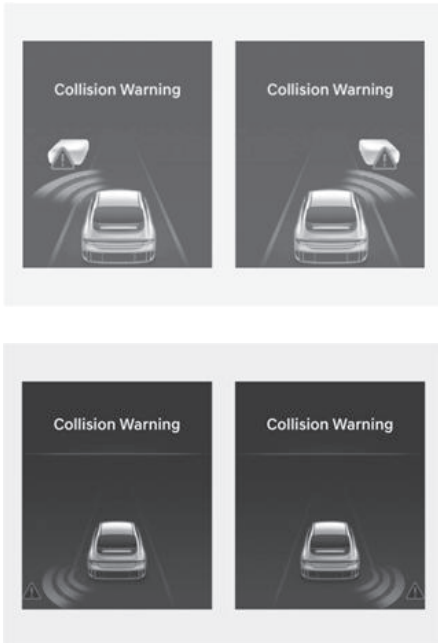

- To warn the driver of a collision, Emergency Steering warning light () blinking, the **'Collision Warning'** warning message will appear on the instrument cluster, an audible warning will sound and the steering wheel will vibrate.
- The function will operate when your vehicle speed is between about 25-90 mph (40-145 km/h).

#### Emergency Steering

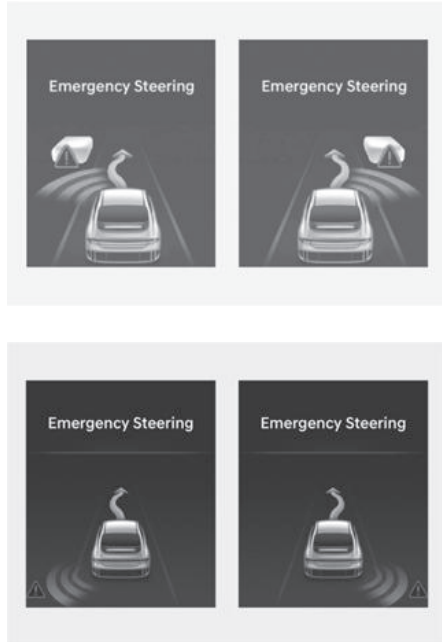

- To warn the driver that emergency steering will be assisted, Emergency Steering warning light () blinking, the **'Emergency Steering'** warning message will appear on the instrument cluster, an audible warning will sound and the steering wheel will vibrate.
- In emergency steering situation, steering is assisted by the function to help prevent collision with the front-side vehicle.
- The function will operate when your vehicle speed is between about 25-90 mph (40-145 km/h) and front-side vehicle and powered two-wheeler is driving.



## ⚠ CAUTION

- Lane-Change Side function does not operate if the speed of the side vehicle or powered two-wheeler from the front side is 0 mph (0 km/h).
- The detecting range of the front corner radar and the rear corner radar is determined by a standard road width, therefore, on a narrow road, Lane-Change Side function may detect other vehicles or powered two-wheelers two lanes over and warn you. In contrast, on a wide road, Lane-Change Side function may not be able to detect a vehicle or powered two-wheeler driving in the next lane and may not warn you.
- Collision-avoidance assist will be canceled under the following circumstances:
  - Your vehicle enters the next lane by a certain distance
  - Your vehicle is away from the collision risk
  - The steering wheel is sharply steered
  - The brake pedal is depressed
  - Forward Collision-Avoidance Assist is operating
- After Lane-Change Side function operation or lane change, you must drive to the center of the lane. Lane-Change Side function will not operate if the vehicle is not driven in the center of the lane.

## *i* Information

- When an additional accident is expected, Lane-Change Side function will not assist with steering and only warn the driver of a collision.

- If the driver's seat is on the left side, collision warning will operate when you turn left, and when it is on the right side, the system will operate when you turn right.

## **Evasive Steering Assist function**

**+** if equipped

Evasive Steering Assist function will warn and control the vehicle with 'Emergency steering'.

### **Emergency Steering (Driver steering assist)**

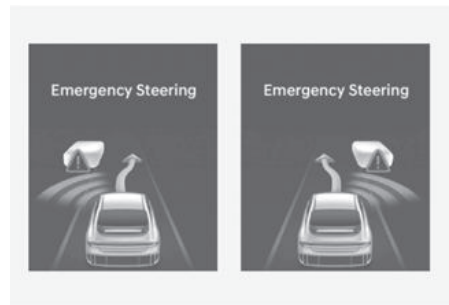

- To warn the driver that emergency steering will be assisted, Emergency Steering warning light (🚗) blinking, the **'Emergency Steering'** message will appear on the instrument cluster, an audible warning will sound and the steering wheel will vibrate.
- If there is a risk of collision with a vehicle, powered two-wheeler, pedestrian and cyclist in front, the steering will be assisted to help prevent collision when the driver steers the vehicle to avoid collision.
- The function will operate when your vehicle speed is between about 25-53 mph (40-85 km/h).

### Emergency Steering (Evasive steering assist)

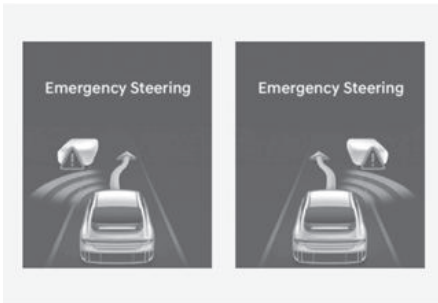

- To warn the driver that emergency steering will be assisted, Emergency Steering warning light (🚨) blinking, the **'Emergency Steering'** message will appear on the instrument cluster, an audible warning will sound and the steering wheel will vibrate.
- The function will operate when your vehicle speed is between about 40-47 mph (65-75 km/h).
- The recognized a powered two-wheeler, pedestrian or cyclist moves in the same direction as your vehicle, or in the opposite direction. In addition, there is sufficient space for an evasive movement for your vehicle. However, this function may not operate for pedestrians or cyclists moving in the horizontal direction.
- If there is high risk of collision with a pedestrian and cyclist in front, and the vehicle speed to operate emergency braking is within the operation range, the steering will be assisted to help prevent collision when there is space to avoid collision in the driving lane.

### ⚠ CAUTION

- The steering wheel may turn automatically when emergency steering is operating.
- Emergency steering will automatically cancel when risk factors disappear. The driver must steer the vehicle.
- Emergency steering may not operate or may cancel during operation if the steering wheel is held tight or steered in the opposite direction.
- When steering is assisted to avoid collision with a vehicle, powered two-wheeler, pedestrian and cyclist, Evasive steering assist will be canceled if collisions with other objects (vehicles, powered two-wheeler, pedestrians, or cyclists) are expected.
- Evasive steering assist may not operate if space to avoid collision in the driving lane is insufficient.

### *i* Information

For more information on warning messages, refer to the Collision Warning in "Basic function".

### ⚠ WARNING

Take the following precautions when using Forward Collision-Avoidance Assist:

- For your safety, only change the Settings after parking the vehicle at a safe location.
- Forward Collision-Avoidance Assist does not operate in all situations and cannot avoid all collisions.
- The driver has the responsibility to control the vehicle. Do not solely depend on Forward Collision-Avoidance Assist. Rather, maintain a safe braking distance, and if necessary, depress the brake pedal

to reduce driving speed or to stop the vehicle.

- Never deliberately operate Forward Collision-Avoidance Assist on people, objects, etc. It may cause serious injury or death.
- Forward Collision-Avoidance Assist may not operate if the driver depresses the brake pedal to avoid a collision.
- Depending on the road and driving conditions, Forward Collision-Avoidance Assist may warn the driver late or may not warn the driver.
- During Forward Collision-Avoidance Assist operation, the vehicle may stop suddenly injuring passengers and shifting loose objects. Always have the seat belt on and keep loose objects secured.
- If any other system's warning message is displayed or audible warning is generated, Forward Collision-Avoidance Assist warning message may not be displayed and audible warning may not be generated.
- You may not hear the warning sound of Forward Collision-Avoidance Assist if the surrounding is noisy.
- Forward Collision-Avoidance Assist may turn off or may not operate properly or may operate unnecessarily depending on the road conditions and the surroundings.
- Even if there is a problem with Forward Collision-Avoidance Assist, the vehicle's basic braking will function normally.
- During emergency braking, braking control by Forward Collision-Avoidance Assist will automatically cancel when the driver excessively depresses the accelerator pedal or sharply steers the vehicle.

### CAUTION

- Depending on the condition of the vehicle, two-wheeled vehicle, pedestrian or cyclist in front and the surroundings, the speed range for Forward Collision-Avoidance Assist to operate may be reduced, and Forward Collision-Avoidance Assist may be limited, or may not operate.
- Forward Collision-Avoidance Assist will operate under certain conditions by judging the risk level based on the condition of the oncoming vehicle or powered two-wheeler, driving direction, speed and surroundings.
- Forward Collision-Avoidance Assist may be limited or disabled if the vehicle or powered two-wheeler speed is too high or the distance to the vehicle ahead is far.
- When a collision with a surrounding vehicle is expected, Lane-Change Oncoming, Lane-Change Side and Evasive Steering Assist will not assist you with steering but only warn the you of a collision (if equipped).



### *i* Information

- In a situation where collision is imminent, braking may be assisted by Forward Collision-Avoidance Assist when braking is insufficient by the driver.
- The images and colors in the instrument cluster may differ depending on the instrument cluster type or theme selected from the settings menu.

## Forward Collision-Avoidance Assist Malfunction and Limitations

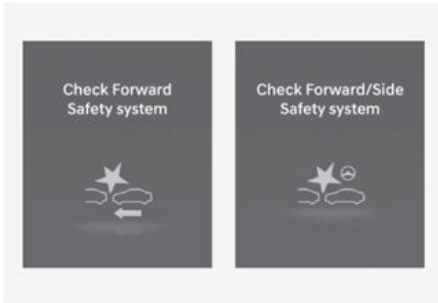
### Forward Collision-Avoidance Assist malfunction



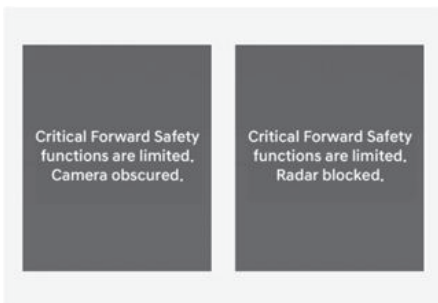

When Forward Collision-Avoidance Assist is not working properly, the '**Check Forward Safety system**' and '**Check Forward/Side Safety system**' warning message will appear, and the ,  and  warning lights will illuminate on the instrument cluster. Have the vehicle inspected by an authorized HYUNDAI dealer.

### Forward Collision-Avoidance Assist disabled



When the front windshield where the front view camera is located, front radar cover, bumper (if equipped) or sensor is covered with foreign material, such as snow or rain, it can reduce the detecting

performance and temporarily limit or disable Forward Collision-Avoidance Assist.

If this occurs the '**Critical Forward Safety functions disabled. Camera obscured**' or the '**Critical Forward Safety functions disabled. Radar blocked**' warning message, and the ,  and  warning lights will illuminate on the instrument cluster.

Forward Collision-Avoidance Assist will operate properly when snow, rain or foreign material is removed.

If Forward Collision-Avoidance Assist does not operate properly after obstruction (snow, rain, or foreign material) is removed (including trailer, carrier, etc., from the rear bumper), have the vehicle inspected by an authorized HYUNDAI dealer.

### WARNING

- Even though the warning message or warning light does not appear on the instrument cluster, Forward Collision-Avoidance Assist may not properly operate.
- Forward Collision-Avoidance Assist may not properly operate in an area (for example, open terrain), where any objects are not detected after turning ON the vehicle.
- If the vehicle is turned off and restarted while the camera is blocked or malfunctioned, the condition is maintained. Therefore, Forward Collision-Avoidance Assist may not operate properly.

### **Limitations of Forward Collision-Avoidance Assist**

Forward Collision-Avoidance Assist may not operate properly, or it may operate unexpectedly under the following circumstances:

- The detecting sensor or the surroundings are contaminated or damaged
- The temperature around the front view camera is high or low due to surrounding environment
- The camera lens is contaminated due to tinted, filmed or coated windshield, damaged glass, or sticky foreign material (sticker, bug, etc.) on the glass
- Moisture is not removed or frozen on the windshield
- Washer fluid is continuously sprayed, or the wiper is on
- Driving in heavy rain or snow, or thick fog
- The field of view of the front view camera is obstructed by sun glare
- Street light or light from an oncoming traffic is reflected on the wet road surface, such as a puddle on the road
- An object is placed on the dashboard
- Your vehicle is being towed
- The surrounding is very bright
- The surrounding is very dark, such as in a tunnel, etc.
- The brightness changes suddenly, for example when entering or exiting a tunnel
- The brightness outside is low, and the headlights are not on or are not bright
- Driving through steam, smoke or shadow
- Only part of the vehicle, powered two-wheeler, pedestrian or cyclist is detected
- The vehicle or powered two-wheeler in front is a bus, heavy truck, truck with an unusually shaped cargo, trailer, etc.
- The vehicle or powered two-wheeler in front has no tail lights, tail lights are located unusually, etc.
- The brightness outside is low, and the tail lights are not on or are not bright
- The rear of the front vehicle is small or the vehicle does not look normal, such as when the vehicle is tilted, overturned, or the side of the vehicle is visible, etc.
- The front vehicle's ground clearance is low or high
- A vehicle, powered two-wheeler, pedestrian or cyclist suddenly cuts in front
- The bumper around the front radar is impacted, damaged or the front radar is out of position
- The temperature around the front radar is high or low
- Driving through a tunnel or iron bridge
- Driving in vast areas where there are few vehicles or structures (for example, desert, meadow, suburb, etc.)
- Driving near areas containing metal substances, such as a construction zone, railroad, etc.
- A material is near that reflects very well on the front radar, such as a guardrail, nearby vehicle, etc.
- The cyclist in front is on a bicycle made of material that does not reflect on the front radar
- The vehicle or powered two-wheeler in front is detected late
- The vehicle or powered two-wheeler in front is suddenly blocked by an obstacle
- The vehicle or powered two-wheeler in front suddenly changes lane or suddenly reduces speed
- The vehicle or powered two-wheeler in front is bent out of shape
- The vehicle in front is covered with snow
- You are departing or returning to the lane
- Unstable driving

- You are on a roundabout and the vehicle or powered two-wheeler in front is not detected
- You are continuously driving in a circle
- The vehicle in front has an unusual shape
- The vehicle in front is driving uphill or downhill
- The pedestrian or cyclist is not fully detected, for example, if the pedestrian is leaning over or is not fully walking upright
- The pedestrian or cyclist is wearing clothing or equipment that makes it difficult to detect



The illustration above shows the image the front view camera and front radar are capable of detecting as a vehicle, pedestrian and cyclist.

- The pedestrian or cyclist in front is moving very quickly
- The pedestrian or cyclist in front is short or is posing a low posture
- The pedestrian or cyclist in front has impaired mobility
- The pedestrian or cyclist in front is moving intersected with the driving direction
- There is a group of pedestrians, cyclists or a large crowd in front
- The pedestrian or cyclist is wearing clothing that easily blends into the background, making it difficult to detect
- The pedestrian or cyclist is difficult to distinguish from the similarly shaped structure in the surroundings

- You are driving by a pedestrian, cyclist, traffic signs, structures, etc., near the intersection
- Driving in a parking lot
- Driving through a tollbooth, construction area, unpaved road, partial paved road, uneven road, speed bumps, etc.
- Driving on an incline road, curved road, etc.
- Driving through a roadside with trees or streetlights
- The adverse road conditions cause excessive vehicle vibrations while driving
- Your vehicle height is low or high due to heavy loads, abnormal tire pressure, etc.
- Driving through a narrow road where trees or grass are overgrown
- There is interference by electromagnetic waves, such as driving in an area with strong radio waves or electrical noise

### Junction Crossing, Lane-Change Oncoming, Lane-Change Side, Evasive Steering Assist function

 If equipped

- The temperature around the front corner radar or rear corner radar is high or low
- A trailer or carrier is installed around the rear corner radar
- The front corner radar or rear corner radar is covered with snow, rain, dirt, etc.
- The bumper around the front corner radar or rear corner radar is covered with objects, such as a bumper sticker, bumper guard, bike rack, etc.
- The bumper around the front corner radar or rear corner radar is impacted, damaged or the radar is out of position
- The front corner radar or rear corner radar is blocked by other vehicles, walls or pillars
- Driving on a highway ramp
- Driving on a road where the guardrail or wall is in double structure

- The other vehicle or powered two-wheeler drives very close behind your vehicle, or the other vehicle or powered two-wheeler passes by your vehicle in close proximity
- The speed of the other vehicle or powered two-wheeler is very fast so that it passes by your vehicle in a short time
- Your vehicle passes by the other vehicle
- Your vehicle has started at the same time as the vehicle or powered two-wheeler next to you and has accelerated
- The vehicle or powered two-wheeler in the next lane moves two lanes away from you, or when the vehicle two lanes away moves to the next lane from you
- A motorcycle or bicycle is detected
- A vehicle such as a flat trailer is detected
- A big vehicle such as a bus or truck is detected
- A small moving obstacle such as a pedestrian, animal, shopping cart or a baby stroller is detected
- A vehicle with low height such as a sports car is detected
- The lane is difficult to see due to foreign material, such as rain, snow, dust, sand, oil and water puddles
- The color of the lane marking is not distinguishable from the road
- There are markings on the road near the lane or the markings on the road looks similar to the lane markings
- The shadow is on the lane marking by a median strip, trees, guardrail, noise barriers, etc.
- The lane number increases or decreases, or the lane markings are crossing
- There are more than two lane markings on the road
- The lane markings are complicated or a structure substitutes for the lines, such as a construction area

- There are road markings, such as zigzag lanes, crosswalk markings and road signs
- The lane suddenly disappears, such as at the intersection
- The lane is very wide or narrow
- There is a curb or road edges without a lane
- The vehicle in front is driving with one side on the lane marking
- The distance to the front vehicle is extremely short

### Limitations of Evasive Steering Assist

Evasive Steering Assist function may not work properly in the following situations when:

- The pedestrians or cyclists are positioned outside of the operating area.

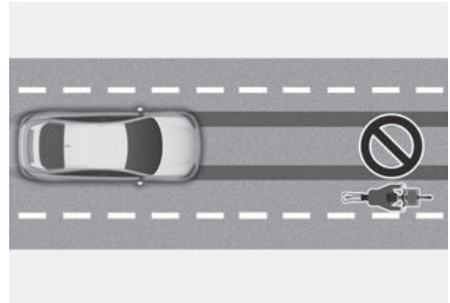

- The pedestrians or cyclists are moving laterally.

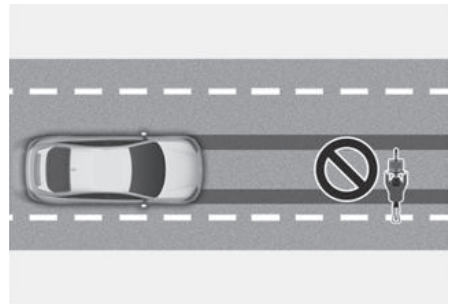

- The pedestrians or cyclists are positioned inside of the operating area, but there is not enough space available for evasive steering.

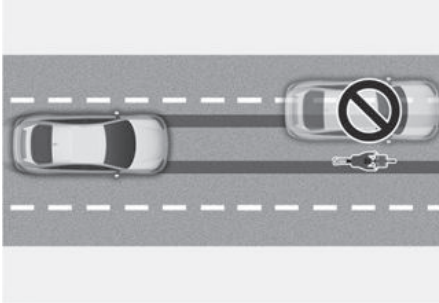

**WARNING**

- Driving on a curved road

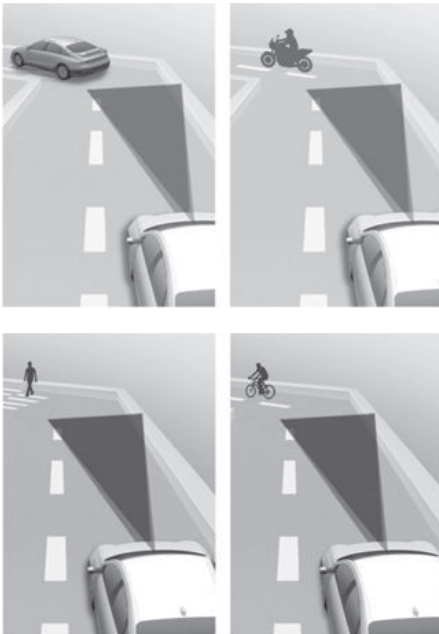

Forward Collision-Avoidance Assist may not detect other vehicles, powered two-wheelers, pedestrians or cyclists in front of you when driving on curved roads adversely affecting the

performance of the sensors. This may result in no warning, braking assist or steering assist (if equipped) when necessary.

When driving on a curve, you must maintain a safe braking distance, and if necessary, steer the vehicle and depress the brake pedal to reduce your driving speed in order to maintain a safe distance.

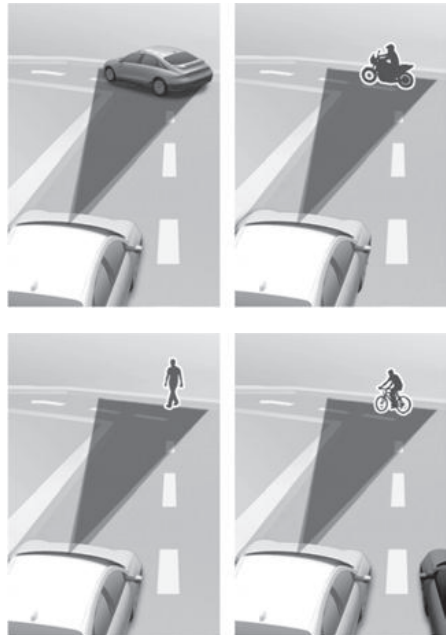

Forward Collision-Avoidance Assist may detect a vehicle, powered two-wheeler, pedestrian or cyclist in the next lane or outside the lane when driving on a curved road.

If this occurs, Forward Collision-Avoidance Assist may unnecessarily warn the driver and control the brake or steering wheel (if equipped). Always check the traffic conditions around the vehicle.



- Driving on an inclined road

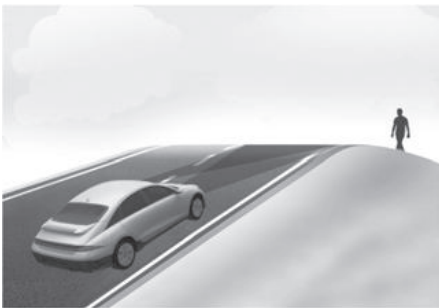
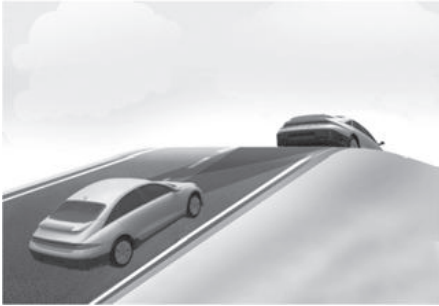

Forward Collision-Avoidance Assist may not detect other vehicles, powered two-wheelers, pedestrians or cyclists in front of you while driving uphill or downhill, adversely affecting the performance of the sensors.

This may result in unnecessary warning, braking assist or steering assist (if equipped) or no warning, braking assist or steering assist (if equipped) when necessary.

Also, vehicle speed may rapidly decrease when a vehicle, powered two-wheeler, pedestrian or cyclist ahead is suddenly detected.

Always have your eyes on the road while driving uphill or downhill and if necessary, steer your vehicle and depress the brake pedal to reduce your driving speed in order to maintain a safe distance.

- Changing lanes



[A] Your vehicle  
[B] Lane changing vehicle

When a vehicle or a powered two-wheeler moves into your lane from an adjacent lane, it cannot be detected by the sensor until it is in the sensor's detection range. Forward Collision-Avoidance Assist may not immediately detect the vehicle or powered two-wheeler when the vehicle or powered two-wheeler changes lanes abruptly. In this case, you must maintain a safe braking distance, and if necessary, steer your vehicle and depress the brake pedal to reduce your driving speed in order to maintain a safe distance.



[A] Your vehicle  
[B] Lane changing vehicle  
[C] Same lane vehicle

When a vehicle in front of you merges out of the lane, Forward Collision-Avoidance Assist may not immediately detect the vehicle or powered two-wheeler that is now in front of you. In this case, you must maintain a safe braking distance, and if necessary, steer your vehicle and depress the brake pedal to reduce your driving speed in order to maintain a safe distance.

- Detecting vehicle

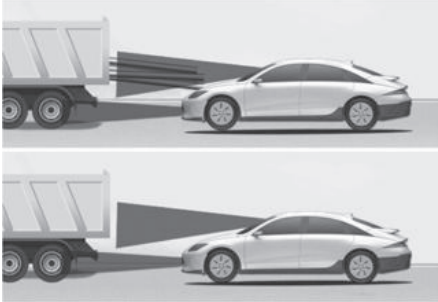

If the vehicle in front of you has cargo that extends rearward from the cab, or when the vehicle in front of you has higher ground clearance, additional special attention is required. Forward Collision-Avoidance Assist may not be able to detect the cargo extending from the vehicle. In these instances, you must maintain a safe braking distance from the rearmost object, and if necessary, steer your vehicle and depress the brake pedal to reduce your driving speed in order to maintain distance.

### WARNING

- When you are towing a trailer or another vehicle, turn off Forward Collision-Avoidance Assist for safety reasons.
- Forward Collision-Avoidance Assist may operate if objects that are similar in shape or characteristics to vehicles, powered two-wheelers, pedestrians and cyclists are detected.
- Forward Collision-Avoidance Assist does not operate on bicycles, or smaller wheeled objects, such as luggage bags, shopping carts, or strollers.
- Forward Collision-Avoidance Assist may not operate properly if interfered by strong electromagnetic waves.

- Forward Collision-Avoidance Assist may not operate for 15 seconds after the vehicle is started, or the front view camera is initialized.

### *i* Information

For more information on the precautions of the rear corner radar, refer to the "Blind-Spot Collision-Avoidance Assist (BCA)" section in this chapter.

### *i* Information

This device complies with Part 15 of the FCC rules.

Operation is subject to the following three conditions:

1. This device may not cause harmful interference, and
2. This device must accept any interference received, including interference that may cause undesired operation.
3. Changes or modifications not expressly approved by the party responsible for compliance could void the user's authority to operate the device.

### *i* Information

Radio frequency radiation exposure information:

This equipment complies with FCC radiation exposure limits set forth for an uncontrolled environment.

This equipment should be installed and operated with minimum distance of 8 in. (20 cm) between the radiator (antenna) and your body.

This transmitter must not be co-located or operating in conjunction with any other antenna or transmitter.

## Lane Keeping Assist (LKA)

While driving over a certain speed, Lane Keeping Assist detects lane markings (or road edges) and may warn you if your vehicle leaves the lane without using the turn signal and may assist with steering to prevent your vehicle departing from its travel lane.

### Detecting sensor



(1) Front view camera

The front view camera is used as a detecting sensor to detect lane markings (or road edges).

Refer to the picture above for the detailed location of the detecting sensor.

### CAUTION

For more information on the precautions of the front view camera, refer to the "Forward Collision-Avoidance Assist (FCA)" section in this chapter.

## Lane Keeping Assist Settings

### Lane Safety

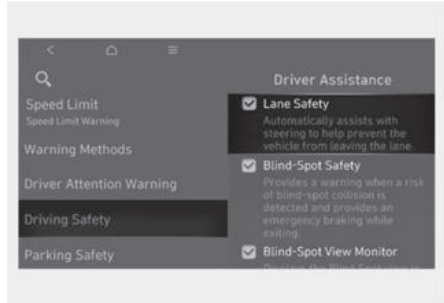

With the vehicle on, select **Setup > Vehicle > Driver Assistance > Driving Safety > Lane Safety** from the Settings menu to set whether to use each function.

If **Lane Safety** is selected, Lane Keeping Assist will automatically assist the driver's steering when lane departure is detected to help prevent the vehicle from moving out of its lane. If **Lane Safety** is deselected, Lane keeping Assist will turn off and the () indicator light will turn off on the instrument cluster.

### WARNING

- Lane Keeping Assist does not control the steering wheel when the vehicle is driven in the middle of the lane.
- The driver should always be aware of the surroundings. If **Lane Safety** is deselected, Lane Keeping Assist cannot assist you.

## Warning Methods

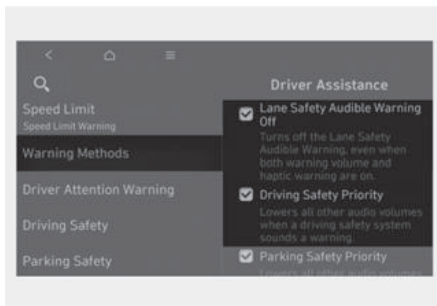
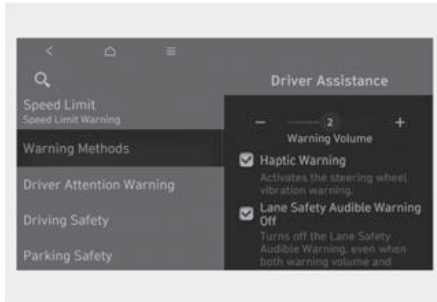

With the vehicle on, go to **Setup > Vehicle > Driver Assistance > Warning Methods** from the Settings in the infotainment system to select the following:

- **Warning Volume:** The Warning Volume can be adjusted.
- **Haptic Warning:** The steering wheel vibration can be set.
- **Lane Safety Audible Warning Off:** The warning volume of Lane Safety does not sound when **Haptic Warning** is selected.
- **Driving Safety Priority:** Your vehicle lowers all other audio volumes when the Driver Assistance system warning sounds.

## *i* Information

- If you change the Warning Methods, Warning Methods of other Driver Assistance systems may change.
- If the vehicle is restarted, Warning Methods will maintain the last setting.
- There may be no Settings menu depending on the feature applied to your vehicle.
- The **Warning Volume** and **Haptic Warning** cannot be turned off at the same time. When one of the warning is turned off, the other is activated.
- **Lane Safety Audible Warning Off** can be set when both **Warning Volume** and **Haptic Warning** turn on.

## Lane Keeping Assist Operation

### Turning Lane Keeping Assist On/Off

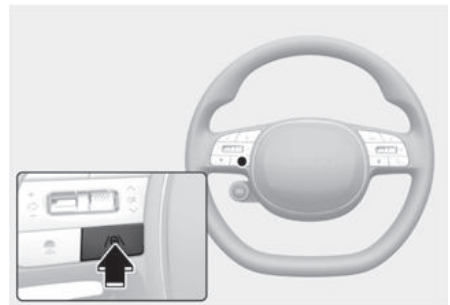

With the vehicle on, press and hold the Lane Driving Assist button (⊕) located on the steering wheel to turn on Lane Keeping Assist. The (⊕) indicator light will illuminate on the instrument cluster.

## *i* Information

When the Lane Driving Assist button is pressed and held, the Lane Safety setting turns off and the (⊕) indicator light will turn off on the instrument cluster.

### Warning and control

Lane Keeping Assist will warn and control the vehicle with Lane Departure Warning and Lane Keeping Assist.

#### Lane Departure Warning

Left



Right



- To warn the driver that the vehicle is departing from the projected lane in front, the green (L) indicator light will blink on the instrument cluster, the lane line will blink on the instrument cluster depending on which direction the vehicle is veering, and an audible warning will sound. Also, the steering wheel will vibrate.
- Lane Departure Warning will operate when your vehicle speed is between about 40-120 mph (60-200 km/h).

### Lane Keeping Assist

- To warn the driver that the vehicle is departing from the projected lane in front, the green (L) indicator light will blink on the cluster, and the steering wheel will make adjustments to keep vehicle inside the lane.
- Lane Keeping Assist will operate when your vehicle speed is between about 40-120 mph (60-200 km/h).

### Hands-off warning

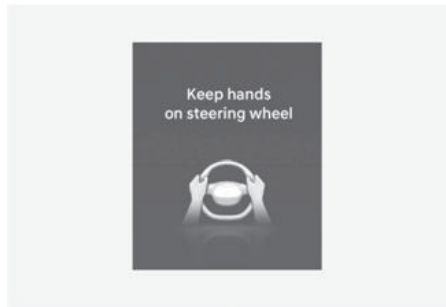

If the driver takes their hands off the steering wheel for several seconds, the **'Keep hands on steering wheel'** warning message will appear on the instrument cluster, and an audible warning will sound in stages.

#### WARNING

- The steering wheel may not be assisted if the steering wheel is held very tight or the steering wheel is steered over a certain degree.
- Lane Keeping Assist does not operate at all times. It is the responsibility of the driver to safely steer the vehicle and to maintain the vehicle in its lane.
- The hands-off warning message may appear late depending on road conditions. Always have your hands on the steering wheel while driving.

- If the steering wheel is held very lightly, the hands-off warning message may appear because Lane Keeping Assist may not recognize that the driver has their hands on the steering wheel.
- If you attach objects to the steering wheel, the hands-off warning may not work properly.

### **i** Information

- For more information on instrument cluster settings, refer to the "Cluster Display Control" section in chapter 4.
- When lane markings (or road edges) are detected, the lane lines on the instrument cluster will change from grey to white.
- When the lane markings (or road edges) are detected and Highway Lane Change Assist is on, the lane lines on the instrument cluster may change to green.

Lane undetected



Lane detected



- The images and colors in the instrument cluster may differ depending on the instrument cluster type or theme selected from the instrument cluster.
- Even though the steering is assisted by Lane Keeping Assist, the driver may control the steering wheel.
- The steering wheel may feel heavier or lighter when the steering wheel is assisted by Lane Keeping Assist than when it is not.

## Lane Keeping Assist Malfunction and Limitations

### Lane Keeping Assist malfunction



When Lane Keeping Assist is not working properly, the '**Check Lane Safety system**' warning message will appear and the yellow (🚗) indicator light will illuminate on the instrument cluster. If this occurs, have the vehicle inspected by an authorized HYUNDAI dealer.

### Lane Keeping Assist disabled

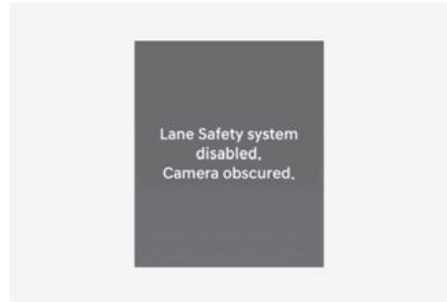

When the front windshield where the front view camera is located, or sensor is covered with foreign material, such as snow or rain, it can reduce the detecting performance and temporarily limit or disable Lane Keeping Assist.

If this occurs, the '**Lane Keeping Assist system disabled. Camera obscured**' warning message and master (⚠️) light or Lane Keeping Assist warning light (🚗) will appear on the instrument cluster.

Lane Keeping Assist will operate properly when snow, rain or foreign material is removed.

If Lane Keeping Assist does not operate properly after it is removed, have the vehicle inspected by an authorized HYUNDAI dealer.

#### **WARNING**

- Even though the warning message or warning light does not appear on the instrument cluster, Lane Keeping Assist may not properly operate.
- If the vehicle is turned off and restarted while the camera is blocked or malfunctioned, the condition is maintained. Therefore, Lane Keeping Assist may not operate properly.



### **Limitations of Lane Keeping Assist**

Lane Keeping Assist may not operate properly or may operate unexpectedly under the following circumstances:

- The lane is contaminated or difficult to detect because:
  - The lane markings (or road edge) are covered with rain, snow, dirt, oil, etc.
  - The color of the lane marking (or road edge) is not distinguishable from the road
  - There are markings (or road edges) on the road near the lane or the markings (or road edges) on the road look similar to the lane markings (or road edge)
  - The lane marking (or road edge) is indistinct or damaged
  - The shadow is on the lane marking (or road edge) by a median strip, trees, guardrail, noise barriers, etc.
- The lane number increases or decreases, or the lane markings (or road edges) are crossing
- There are more than two lane markings (or road edges) on the road
- The lane markings (or road edges) are complicated or a structure substitutes for the lines, such as a construction area
- There are road markings, such as zigzag lanes, crosswalk markings and road signs
- The lane suddenly disappears, such as at the intersection
- The lane (or road width) is very wide or narrow
- There is a road edge without a lane
- There is a boundary structure in the roadway, such as a tollbooth, sidewalk, curb, etc.
- The distance to the front vehicle is extremely short or the vehicle in front is covering the lane marking (or road edge)

### **i Information**

For more information on the limitations of the front view camera, refer to the "Forward Collision-Avoidance Assist (FCA)" section in this chapter.

### **⚠ WARNING**

Take the following precautions when using Lane Keeping Assist:

- The driver has the responsibility to safely drive and control the vehicle. Do not solely rely on Lane Keeping Assist.
- The operation of Lane Keeping Assist can be cancelled or not work properly depending on road conditions and surroundings. Always be cautious while driving.
- Refer to the "Limitations of Lane Keeping Assist" if the lane is not detected properly.
- When you are towing a trailer or another vehicle, turn off Lane Keeping Assist for safety reasons.
- If the vehicle is driven at high speed, the steering wheel will not be controlled. The driver must always follow the speed limit when using Lane Keeping Assist.
- If any other system's warning message is displayed or audible warning is generated, Lane Keeping Assist warning message may not be displayed and audible warning may not be generated.
- You may not hear the warning sound of Lane Keeping Assist if the surrounding is noisy.
- If you attach objects to the steering wheel, steering may not be assisted properly.
- Lane Keeping Assist may not operate for 15 seconds after the vehicle is started, or the front view camera is initialized.

- Lane Keeping Assist will not operate when:
    - The turn signal or hazard warning flasher is turned on.
    - The vehicle is not driven in the center of the lane when Lane Keeping Assist is turned on or right after changing a lane.
    - ESC (Electronic Stability Control) or VSM (Vehicle Stability Management) is activated.
    - The vehicle is driven on a sharp curve.
    - Vehicle speed is below 35 mph (55 km/h) or above 130 mph (210 km/h).
    - The vehicle makes sudden lane changes.
    - The vehicle brakes suddenly.
  - Loading freight exceeding the maximum load or placing freight unevenly may undermine driving safety. This may also prevent Lane Keeping Assist from operating properly.
- 

## Blind-Spot Collision-Avoidance Assist (BCA)

Blind-Spot Collision-Avoidance Assist detects approaching vehicles in the driver's blind spot areas and warn you of a possible collision with a warning light and a warning sound.

If there is a collision risk when exiting a parallel space, Blind-Spot Collision-Avoidance Assist may assist with braking your vehicle to help avoid a collision.

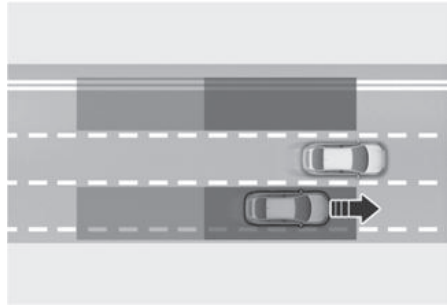

Blind-Spot Collision-Avoidance Assist helps detect and informs the driver that a vehicle is in the blind spot.

### CAUTION

The detecting range may vary depending on the speed of your vehicle. Even if there is a vehicle in the blind spot area, Blind-Spot Collision-Avoidance Assist may not warn you when you pass by at high speeds.

---

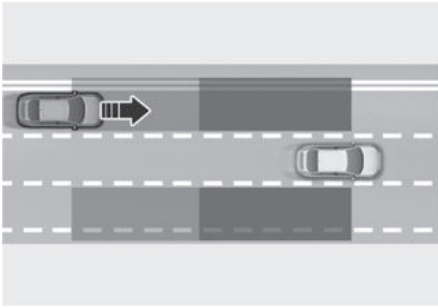

Blind-Spot Collision-Avoidance Assist helps detect and informs the driver that a vehicle is approaching at high speed from the blind spot area.

### CAUTION

Warning timing may vary depending on the speed of the vehicle approaching at high speed.

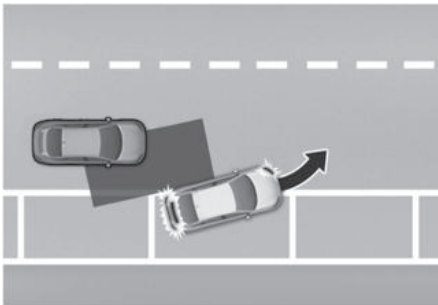

When you are driving forward out of a parking space, if Blind-Spot Collision-Avoidance Assist judges that there is a collision risk with an approaching vehicle in the blind spot, it can help avoid collision by applying the brake.

## Detecting sensor

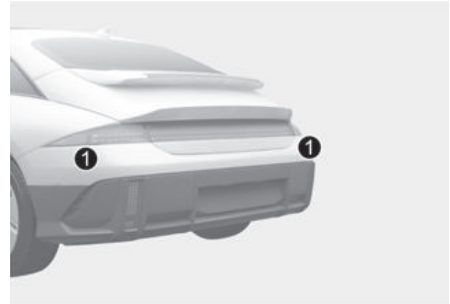

(1) Rear corner radar

Refer to the picture above for the detailed location of the detecting sensors.

### CAUTION

Take the following precautions to maintain optimal performance of the detecting sensor:

- Never disassemble the detecting sensor assembly, or cause any damage to it.
- If the rear corner radar or near the radar has been damaged or impacted in any way, even though the warning message does not appear on the instrument cluster, Blind-Spot Collision-Avoidance Assist may not operate properly. Have the vehicle inspected by an authorized HYUNDAI dealer.
- If the rear corner radars have been replaced or repaired, have the vehicle inspected by an authorized HYUNDAI dealer.
- Rear bumper genuine parts with rear corner radars have proven their performance. Replacing or painting the rear bumper may result in poor performance of Blind-Spot Collision-Avoidance Assist. When the parts need to be replaced or modified, make sure to use genuine HYUNDAI parts.

- Do not apply license plate frame or objects, such as a bumper sticker, film or a bumper guard near the rear corner radar.
- Blind-Spot Collision-Avoidance Assist may not work properly if the bumper has been replaced, or the surroundings of the rear corner radar have been damaged or paint has been applied.
- If a trailer, carrier, etc., is installed, it may adversely affect the performance of the rear corner radar or Blind-Spot Collision-Avoidance Assist may not operate.

### Blind-Spot Collision-Avoidance Assist settings

#### Blind-Spot Safety

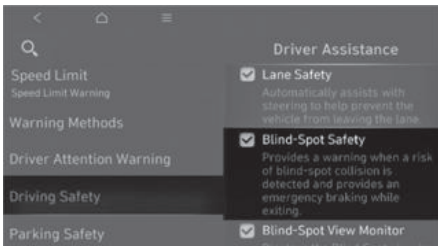

With the vehicle on, select **Setup > Vehicle > Driver Assistance > Driving Safety > Blind-Spot Safety** from the settings menu to set whether to use each function.

- If **Blind-Spot Safety** is selected, Blind-Spot Collision Avoidance Assist will warn the driver with a warning message, an audible warning depending on the collision risk levels. Braking assist will be applied for parking exit depending on the collision risk levels.

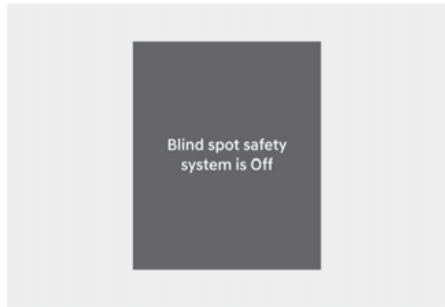

When the vehicle is restarted with Blind-Spot Collision-Avoidance Assist off, the '**Blind-spot safety system is Off**' message will appear on the instrument cluster.

If you select **Blind-Spot Safety**, warning light on the side view mirror will blink for three seconds. In addition, if the vehicle is turned on, when **Blind-Spot Safety** is selected, the warning light on the side view mirror will blink for three seconds.

#### **WARNING**

The driver should always be aware of the surroundings and drive safely. If **Blind-Spot Safety** is deselected, Blind-Spot Collision-Avoidance Assist cannot assist you.

#### **Information**

If the vehicle is restarted, Blind-Spot Collision-Avoidance Assist will maintain the last setting.

## Warning Methods

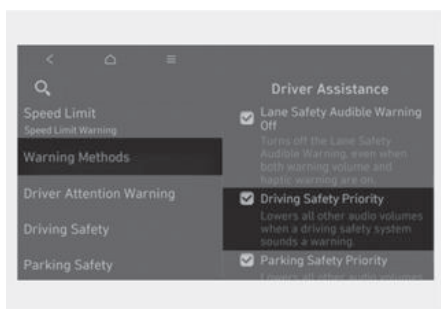
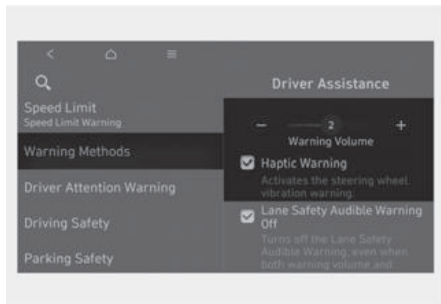

With the vehicle on, go to **Setup > Vehicle > Driver Assistance > Warning Methods** from the Settings in the infotainment system to select the following:

- **Warning Volume:** The Warning Volume can be adjusted.
- **Haptic Warning:** The steering wheel vibration can be set.
- **Driving Safety Priority:** Your vehicle lowers all other audio volumes when the Driver Assistance system warning sounds.

## *i* Information

- If you change the Warning Methods, Warning Methods of other Driver Assistance systems may change.
- If the vehicle is restarted, Warning Methods will maintain the last setting.
- There may be no Settings menu depending on the feature applied to your vehicle.
- The **Warning Volume** and **Haptic Warning** cannot be turned off at the same time. When one of the warnings is turned off, the other is activated.

## Blind-Spot Collision-Avoidance Assist Operation

### Collision Warning (while driving)



To warn the driver a vehicle is detected, the warning light on the side view mirror illuminates.

Vehicle detection operates under following conditions.

- Your vehicle speed: above 12 mph (20 km/h)
- Vehicle in the blind spot area: above 7 mph (10 km/h)

Collision warning operates when the turn signal is turned on in the direction of the detected vehicle.

- To warn the driver of a collision, the warning light on the side view mirror blinks. At the same time, an audible warning sounds and the steering wheel vibrates.
- When the turn signal is turned off, the collision warning is canceled and Blind-Spot Collision-Avoidance Assist returns to vehicle detection state.

Collision warning operates under following conditions.

- Your vehicle speed: above 25 mph (40 km/h)
- Vehicle in the blind spot area: above 7 mph (10 km/h)

### WARNING

- The detecting range of the rear corner radar is determined by a standard road width, therefore, on a narrow road, Blind-Spot Collision-Avoidance Assist may detect other vehicles two lanes over and warn you. In contrast, on a wide road, Blind-Spot Collision-Avoidance Assist may not be able to detect a vehicle driving in the next lane and may not warn you.
- When the hazard warning flasher is on, the collision warning by the turn signal will not operate.

### Information

The images and colors in the instrument cluster may differ depending on the instrument cluster type or theme selected from the settings menu.

### **Collision-Avoidance Assist (while exiting parallel spot)**



- To warn the driver of a collision, the warning light on the side view mirror will blink and a warning message will appear on the instrument cluster. At the same time, an audible warning will sound, warning light on the head-up display (if equipped) will blink and the steering wheel will vibrate.
- Emergency braking will be assisted to help prevent collision with the vehicle in the blind spot area.
- Blind-Spot Collision-Avoidance Assist will operate when your vehicle speed is below 2 mph (3 km/h) and the speed of the vehicle in the blind spot area is above 3 mph (5 km/h).



- When the vehicle is stopped due to emergency braking, the **'Drive carefully'** warning message will appear on the instrument cluster.

For your safety, the driver should depress the brake pedal immediately and check the surroundings.

- Brake control will end after the vehicle is stopped by emergency braking for about 2 seconds.

### **WARNING**

Take the following precautions when using Blind-Spot Collision-Avoidance Assist:

- For your safety, only change the Settings after parking the vehicle at a safe location.
- If any other system's warning message is displayed or audible warning is generated, Blind-Spot Collision-Avoidance Assist's warning message may not be displayed and audible warning may not be generated.
- You may not hear the warning sound of Blind-Spot Collision-Avoidance Assist if the surrounding is noisy.
- Blind-Spot Collision-Avoidance Assist may not operate if the driver applies the brake pedal to avoid a collision.

- When Blind-Spot Collision-Avoidance Assist is operating, braking control by the function will automatically cancel when the driver excessively depresses the accelerator pedal or sharply steers the vehicle.
- During Blind-Spot Collision-Avoidance Assist operation, the vehicle may stop suddenly injuring passengers and shifting loose objects. Always have the seat belt on and keep loose objects secured.
- Even if there is a problem with Blind-Spot Collision-Avoidance Assist, the vehicle's basic braking will function normally.
- Blind-Spot Collision-Avoidance Assist does not operate in all situations and cannot avoid all collisions.
- Blind-Spot Collision-Avoidance Assist may warn the driver late or may not warn the driver depending on the road and driving conditions.
- Driver should maintain control of the vehicle at all times. Do not depend on Blind-Spot Collision-Avoidance Assist. Maintain a safe braking distance, and if necessary, depress the brake pedal to reduce driving speed or to stop the vehicle.
- Never operate Blind-Spot Collision-Avoidance Assist on people, animal, objects, etc. It may cause serious injury or death.

### **WARNING**

The brake control may not operate properly depending on the status of ESC (Electronic Stability Control).

There will only be a warning when:

- The ESC (Electronic Stability Control) warning light is on
- ESC (Electronic Stability Control) is engaged in a different function

## Blind-Spot Collision-Avoidance Assist Malfunction and Limitations

### Blind-Spot Collision-Avoidance Assist malfunction

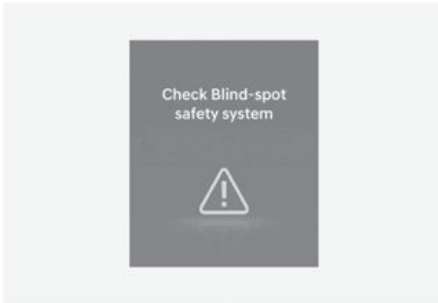

When Blind-Spot Collision-Avoidance Assist is not working properly, the **'Check Blind-spot safety system'** warning message will appear on the instrument cluster for several seconds, and the master (⚠) warning light will illuminate on the instrument cluster. If this occurs, have the vehicle inspected by an authorized HYUNDAI dealer.

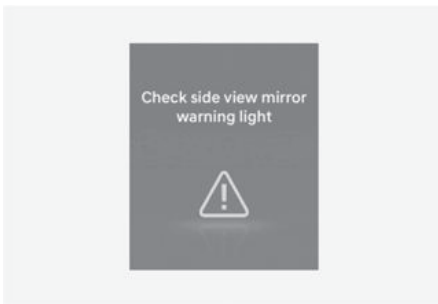

When the side view mirror warning light is not working properly, the **'Check side view mirror warning light'** warning message will appear on the instrument cluster for several seconds, and the master (⚠) warning light will illuminate on the instrument cluster. If this occurs, have

the vehicle inspected by an authorized HYUNDAI dealer.

### Blind-Spot Collision-Avoidance Assist disabled

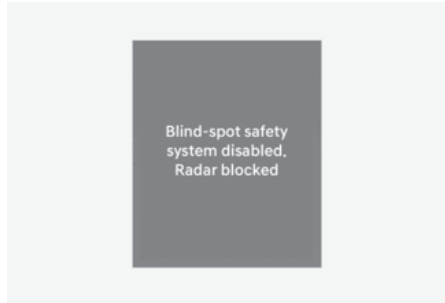

When the rear bumper around the rear corner radar or sensor is covered with foreign material, such as snow or rain, or installing a trailer or carrier, it can reduce the detecting performance and temporarily limit or disable Blind-Spot Collision-Avoidance Assist.

If this occurs, the **'Blind-Spot Safety system disabled. Radar blocked'** warning message will appear on the instrument cluster.

Blind-Spot Collision-Avoidance Assist will operate properly when such foreign material or trailer, etc., is removed, and then the vehicle is restarted.

If Blind-Spot Collision-Avoidance Assist does not operate properly after it is removed, have the vehicle inspected by an authorized HYUNDAI dealer.

### WARNING

- Even though the warning message does not appear on the instrument cluster, Blind-Spot Collision-Avoidance Assist may not properly operate.
- Blind-Spot Collision-Avoidance Assist may not properly operate in an area (for example, open terrain) where any objects are not detected right after the vehicle is turned on, or when the



detecting sensor is blocked with foreign material right after the vehicle is turned on.

### CAUTION

Turn off Blind-Spot Collision-Avoidance Assist to install or remove a trailer, carrier, or another attachment. Turn on Blind-Spot Collision-Avoidance Assist when finished.

### **Limitations of Blind-Spot Collision-Avoidance Assist**

Blind-Spot Collision-Avoidance Assist may not operate properly, or it may operate unexpectedly under the following circumstances:

- There is inclement weather, such as heavy snow, heavy rain, etc.
- The rear corner radar is covered with snow, rain, dirt, etc.
- The temperature around the rear corner radar is high or low
- Driving on a highway ramp
- The road pavement (or the peripheral ground) abnormally contains metallic components (for example, possibly due to subway construction)
- There is a fixed object near the vehicle, such as sound barriers, guardrails, central dividers, entry barriers, street lamps, signs, tunnels, walls, etc. (including double structures)
- Driving in vast areas where there are few vehicles or structures (for example, desert, meadow, suburb, etc.)
- Driving through a narrow road where trees or grass are overgrown
- Driving on a wet road surface, such as a puddle on the road
- The other vehicle drives very close behind your vehicle, or the other vehicle passes by your vehicle in close proximity

- The speed of the other vehicle is very fast that it passes by your vehicle in a short time
- Your vehicle passes by the other vehicle
- Your vehicle changes lane
- Your vehicle has started at the same time as the vehicle next to you and has accelerated
- The vehicle in the next lane moves two lanes away from you, or when the vehicle two lanes away moves to the next lane from you
- A trailer, carrier or other attachment is installed around the rear corner radar
- The bumper around the rear corner radar is covered with objects, such as a bumper sticker, bumper guard, bike rack, etc.
- The bumper around the rear corner radar is impacted, damaged or the radar is out of position
- Your vehicle height is low or high due to heavy loads, abnormal tire pressure, etc.

Blind-Spot Collision-Avoidance Assist may not operate properly, or it may operate unexpectedly when the following objects are detected:

- A motorcycle or bicycle is detected
- A vehicle such as a flat trailer is detected
- A big vehicle such as a bus or truck is detected
- A moving obstacle such as a pedestrian, animal, shopping cart or a baby stroller is detected
- A vehicle with low height such as a sports car is detected

Braking control may not work, driver's attention is required in the following circumstances:

- The vehicle severely vibrates while driving over a bumpy road, uneven road or concrete patch

- Driving on a slippery surface due to snow, water puddle, ice, etc.
- The tire pressure is low or a tire is damaged
- The braking system has been modified
- The vehicle makes abrupt lane changes

### **i** Information

For more information on the limitations of the front view camera, refer to the “Forward Collision-Avoidance Assist (FCA)” and “Lane Keeping Assist (LKA)” section in this chapter.

### **!** WARNING

- Driving on a curved road

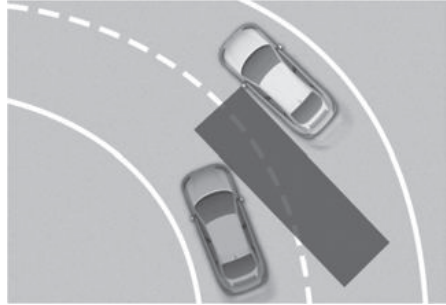

Blind-Spot Collision-Avoidance Assist may not operate properly when driving on a curved road. The function may not detect the vehicle in the next lane.

Always pay attention to road and driving conditions while driving.

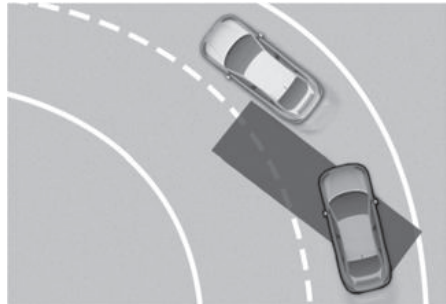

Blind-Spot Collision-Avoidance Assist may not operate properly when driving on a curved road. The function may recognize a vehicle in the same lane.

Always pay attention to road and driving conditions while driving.

- Driving on an inclined road

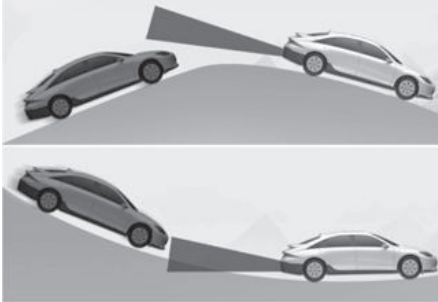

Blind-Spot Collision-Avoidance Assist may not operate properly when driving on a slope. The function may not detect the vehicle in the next lane or may incorrectly detect the ground or structure. Always pay attention to road and driving conditions while driving.

- Driving where the road is merging/dividing

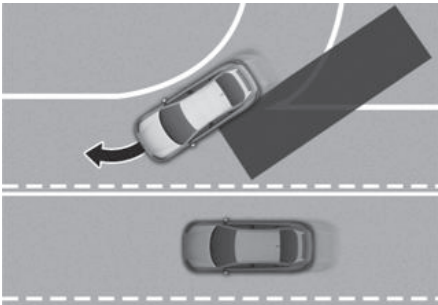

Blind-Spot Collision-Avoidance Assist may not operate properly when driving where the road merges or divides. The function may not detect the vehicle in the next lane.

Always pay attention to road and driving conditions while driving.

- Driving where the heights of the lanes are different

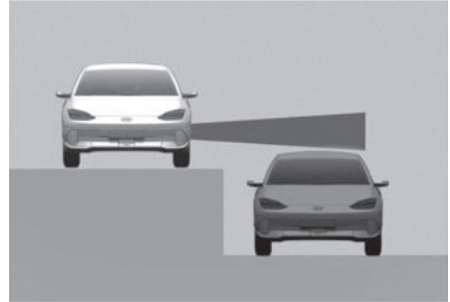

Blind-Spot Collision-Avoidance Assist may not operate properly when driving where the heights of the lanes are different. The function may not detect the vehicle on a road with different lane heights (underpass joining section, grade separated intersections, etc.). Always pay attention to road and driving conditions while driving.

#### **WARNING**

- When you are towing a trailer or another vehicle, make sure that you turn off Blind-Spot Collision-Avoidance Assist.
- Blind-Spot Collision-Avoidance Assist may not operate properly if interfered by strong electromagnetic waves.
- Blind-Spot Collision-Avoidance Assist may not operate for 3 seconds after the vehicle is started, or the front view camera or rear corner radars are initialized.

### **i** Information

This device complies with Part 15 of the FCC rules.

Operation is subject to the following three conditions:

1. This device may not cause harmful interference, and
2. This device must accept any interference received, including interference that may cause undesired operation.
3. Changes or modifications not expressly approved by the party responsible for compliance could void the user's authority to operate the device.

### **i** Information

Radio frequency radiation exposure information:

This equipment complies with FCC radiation exposure limits set forth for an uncontrolled environment.

This equipment should be installed and operated with minimum distance of 8 in. (20 cm) between the radiator (antenna) and your body.

This transmitter must not be co-located or operating in conjunction with any other antenna or transmitter.

## Safe Exit Warning (SEW)

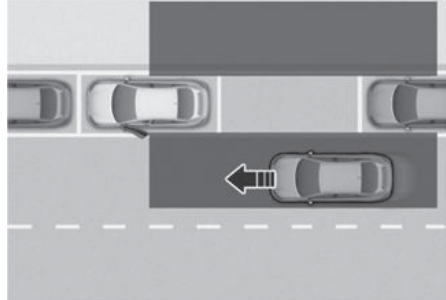

While your vehicle is stopped, and if Safe Exit Warning detects a vehicle approaching the rear corner of your vehicle and a passenger opens a door, Safe Exit Warning may warn you with a warning message and a warning sound to help avoid a collision.

### **!** CAUTION

Warning timing may vary depending on the speed of the approaching vehicle.

## Detecting sensor

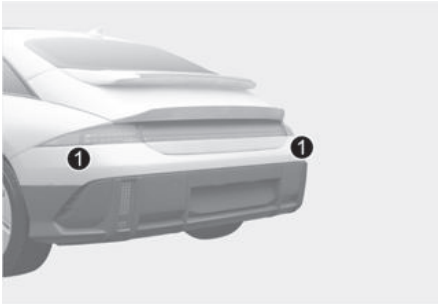

(1) Rear corner radar

Refer to the picture above for the detailed location of the detecting sensors.

### CAUTION

For more information on the precautions of the rear corner radars, refer to the “Blind-Spot Collision-Avoidance Assist (BCA)” section in this chapter.

## Safe Exit Warning Settings

### Exit Safety

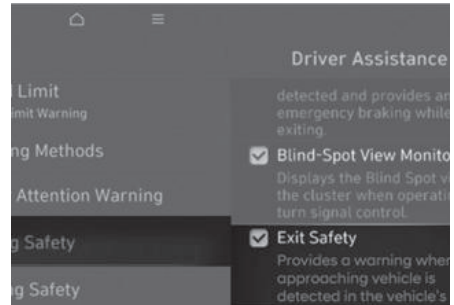

With the vehicle on, select **Setup** > **Vehicle** > **Driver Assistance** > **Driving Safety** > **Exit Safety** from the Settings menu to turn on Safe Exit Warning and deselect to turn off the function.

### WARNING

The driver should always be aware of the surroundings. If **Exit Safety** is deselected, Safe Exit Warning cannot assist you.

### Information

If the vehicle is restarted, Safe Exit Warning will maintain the last setting.

## Warning Methods

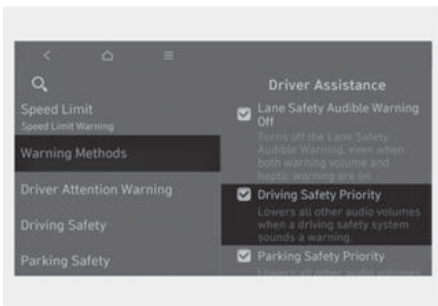
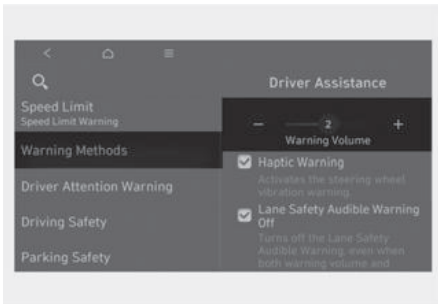

With the vehicle on, go to **Setup > Vehicle > Driver Assistance > Warning Methods** from the Settings in the infotainment system to select the following:

- **Warning Volume:** The Warning Volume can be adjusted.  
If you turn off the **Warning Volume**, for your safety, the function may warn you with a low volume.
- **Driving Safety Priority:** Your vehicle lowers all other audio volumes when the Driver Assistance system warning sounds.

### **i** Information

- If you change the Warning Methods, Warning Methods of other Driver Assistance systems may change.
- If the vehicle is restarted, Warning Methods will maintain the last setting.

- There may be no Settings menu depending on the feature applied to your vehicle.

## Safe Exit Warning Operation

### Safe Exit Warning

Safe Exit Warning will warn and control the vehicle with Collision warning when exiting vehicle.

### Collision warning when exiting vehicle

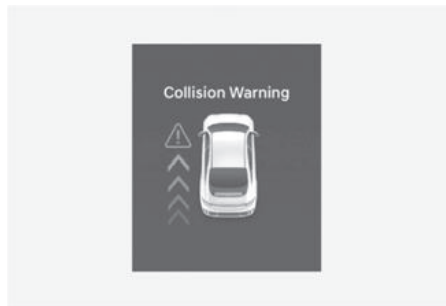

- When an approaching vehicle from the rear is detected at the moment a door is opened, the **'Collision Warning'** warning message will appear on the instrument cluster, and an audible warning will sound.
- Safe Exit Warning will warn the driver when your vehicle speed is below 2 mph (3 km/h), and the speed of the approaching vehicle from the rear is above 4 mph (6 km/h).

## WARNING

Take the following precautions when using Safe Exit Warning:

- For your safety, only change the Settings after parking the vehicle at a safe location.
- If any other system's warning message is displayed or audible warning is generated, Safe Exit Warning's warning message may not be displayed and audible warning may not be generated.
- You may not hear the warning sound of Safe Exit Warning if the surroundings are noisy.
- Safe Exit Warning does not operate in all situations and cannot prevent all collisions.
- Safe Exit Warning may warn the driver late or may not warn the driver depending on the road and driving conditions. Always check vehicle surroundings.
- The driver and passengers are responsible for accidents that occur while exiting the vehicle. Always check the surroundings before you exit the vehicle.

## Information

- After the vehicle is turned off, Safe Exit Warning operates about for 3 minutes, but turns off immediately if the doors are locked.
- The images and colors in the instrument cluster may differ depending on the instrument cluster type or theme selected from the settings menu.

## Safe Exit Warning Malfunction and Limitations

### Safe Exit Warning malfunction

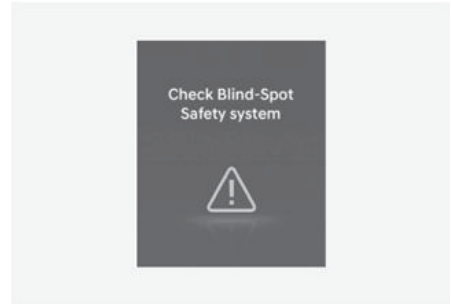

When Safe Exit Warning is not working properly, the '**Check Blind-Spot Safety system**' warning message will appear on the instrument cluster for several seconds, and the master (⚠) warning light will illuminate on the instrument cluster. If this occurs, have the vehicle inspected by an authorized HYUNDAI dealer.

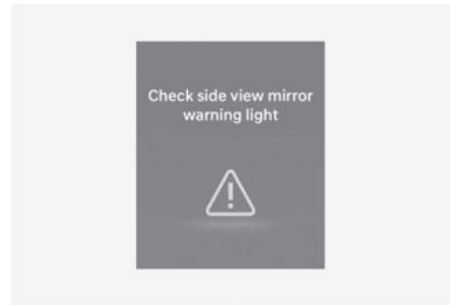

When the side view mirror warning light is not working properly, the '**Check side view mirror warning light**' warning message will appear on the instrument cluster for several seconds, and the master (⚠) warning light will illuminate on the instrument cluster. If this occurs, have the vehicle inspected by an authorized HYUNDAI dealer.

### Safe Exit Warning disabled

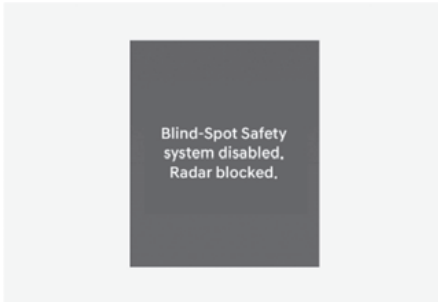

When the rear bumper around the rear corner radar or sensor is covered with foreign material, such as snow or rain, or installing a trailer or carrier, it can reduce the detecting performance and temporarily limit or disable Safe Exit Warning.

If this occurs, the **'Blind-Spot Safety system disabled. Radar blocked'** warning message will appear on the instrument cluster.

Safe Exit Warning will operate properly when such foreign material or trailer, etc., is removed, and then the vehicle is restarted.

If Safe Exit Warning does not operate properly after it is removed, have the vehicle inspected by an authorized HYUNDAI dealer.

#### WARNING

- Even though the warning message does not appear on the instrument cluster, Safe Exit Warning may not properly operate.
- Safe Exit Warning may not properly operate in an area (for example, open terrain) where any objects are not detected right after the vehicle is turned on, or when the detecting sensor is blocked with foreign material right after the vehicle is turned on.

#### CAUTION

Turn off Safe Exit Warning to install or remove a trailer, carrier, or another attachment. Turn on Safe Exit Warning when finished.

#### **Limitations of Safe Exit Warning**

Safe Exit Warning may not operate properly, or it may operate unexpectedly under the following circumstances:

- Getting out of the vehicle where trees or grass are overgrown
- Getting out of the vehicle where the road is wet
- The approaching vehicle is very fast or very slow

#### Information

For more information on the limitations of the rear corner radar, refer to the “Blind-Spot Collision-Avoidance Assist (BCA)” section in this chapter.

#### WARNING

- Safe Exit Warning may not operate properly if interfered by strong electromagnetic waves.
- Safe Exit Warning may not operate for 3 seconds after the vehicle is started, or the rear corner radars are initialized.
- If the vehicle is turned off and restarted while the rear corner radar is blocked or malfunctioned, the condition is maintained. Therefore, Safe Exit Warning may not operate properly.



## Manual Speed Limit Assist (MSLA)

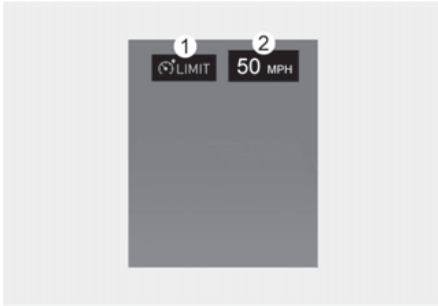

- (1) Speed Limit indicator
- (2) Set speed



You can set the speed limit when you do not want to drive over a specific speed.

If you drive over the preset speed limit, Manual Speed Limit Assist will operate (set speed limit will blink and chime will sound) until the vehicle speed returns within the speed limit.

## Manual Speed Limit Assist Operation

### Setting speed limit



1. Press and hold Driving Assist () button at the desired speed. The Speed Limit () indicator will illuminate on the instrument cluster.



2. Push the + switch up or - switch down, and release it at the desired speed.

Push the + switch up or - switch down and hold it. The speed will increase or decrease to the nearest multiple of five (multiple of ten in km/h) at first, and then increase or decrease by 5 mph (10 km/h).



3. The set speed limit will be displayed on the instrument cluster.

If you would like to drive over the preset speed limit, depress the accelerator pedal deeply

The set speed limit will blink and chime will sound until you return the vehicle speed within the speed limit.

### *i* Information

The set speed may differ depending on the vehicle specifications. You may not increase the set speed above the maximum set speed.

### Temporarily pausing Manual Speed Limit Assist

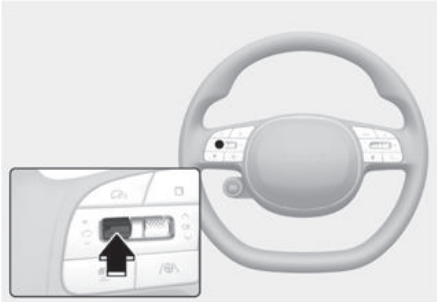

Press the || switch to temporarily pause the set speed limit. The set speed limit will turn off but the Speed Limit (LIMIT) indicator will stay on.

### Resuming Manual Speed Limit Assist

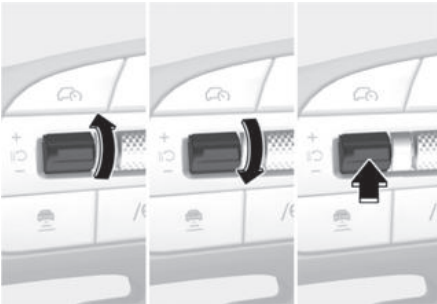

To resume Manual Speed Limit Assist after the function was paused, operate the +, -, || switch.

If you push the + switch up or - switch down, vehicle speed will be set to the current speed on the instrument cluster.

If you press the || switch, vehicle speed will resume to the preset speed.

### Turning off Manual Speed Limit Assist



Press the Driving Assist (DA) button to turn Manual Speed Limit Assist off. The Speed Limit (LIMIT) indicator will go off.

### WARNING

Take the following precautions when using Manual Speed Limit Assist:

- Always set the vehicle speed to the speed limit in your state.
- Keep Manual Speed Limit Assist off when the function is not in use, to avoid inadvertently setting a speed. Check that the Speed Limit (LIMIT) indicator is off.
- Manual Speed Limit Assist does not substitute for proper and safe driving. It is the responsibility of the driver to always drive safely and be aware of unexpected and sudden situations. Pay attention to the road conditions at all times.

## Intelligent Speed Limit Assist (ISLA)

 if equipped

Intelligent Speed Limit Assist uses information from the detected road signs and uses the navigation system data to inform you of the speed limit and to help maintain within the speed limit on the road.

### CAUTION

- Intelligent Speed Limit Assist may not operate properly if the function is used in other countries.
- If a navigation system is equipped to your vehicle, the navigation needs to be regularly updated for Intelligent Speed Limit Assist to operate properly.
- The infotainment system may change after software updates. For more information, refer to the user's manual provided in the infotainment system and the quick reference guide.

### *Detecting sensor*



(1) Front view camera

Refer to the picture above for the detailed location of the detecting sensor.

### CAUTION

For more information on the precautions of the front view camera, refer to the Forward Collision-Avoidance Assist (FCA) section in this chapter.

## Intelligent Speed Limit Assist Settings

### Speed Limit

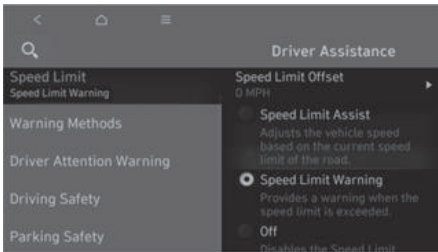

With the vehicle on, select or deselect **Setup > Vehicle > Driver Assistance > Speed Limit** from the Settings menu to set whether to use each function.

- If **Speed Limit Offset** is selected, the Speed Limit Offset can be adjusted. Speed Limit Warning and Speed Limit Assist will warn the driver and adjust the driving speed when vehicle speed exceeds the speed at which the set Offset is added to speed limit.
- If **Speed Limit Assist** is selected, Intelligent Speed Limit Assist will inform the driver of speed limit and additional road signs. In addition, Intelligent Speed Limit Assist will inform the driver to change set speed of Manual Speed Limit Assist and/or Smart Cruise Control to help the driver stay within the speed limit.
- If **Speed Limit Warning** is selected, Intelligent Speed Limit Assist will inform the driver of speed limit. In addition, Intelligent Speed Limit Assist will warn the driver when the vehicle is driven faster than the speed limit.
- If **Off** is selected, Intelligent Speed Limit Assist will turn off.

### WARNING

For your safety, only change the Settings after parking the vehicle at a safe location.

### Information

- Speed Limit Assist function operates based on the Offset setting added to the speed limit. If you want to change the set speed according to the speed limit, adjust the offset to '0'.
- The setting of 'Speed Offset' is not reflected in Navigation-based Smart Cruise Control (NSCC).

## Intelligent Speed Limit Assist Operation

### **Warning and control**

Intelligent Speed Limit Assist will warn and control the vehicle speed by “Displaying speed limit”, “Warning overspeed” and “Changing set speed”.

### Information

- Intelligent Speed Limit Assist warning and control are described based on the Offset adjust to "0". For details on Offset setting, refer to the “Intelligent Speed Limit Assist Settings”.

## Displaying speed limit

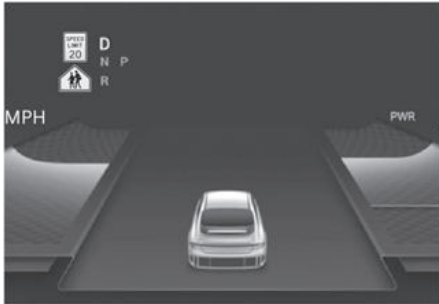

Speed limit information is displayed on the instrument cluster.

### *i* Information

- If speed limit information of the road cannot be recognized, '---' sign will be displayed. Please refer to "Limitations of Intelligent Speed Limit Assist" if the road signs are difficult to recognize.
- Intelligent Speed Limit Assist provides additional road sign information in addition to speed limit. The additional road sign information provided may vary according to your state.
- The images and colors in the instrument cluster may differ depending on the instrument cluster type or theme selected from the instrument cluster.

## Warning overspeed

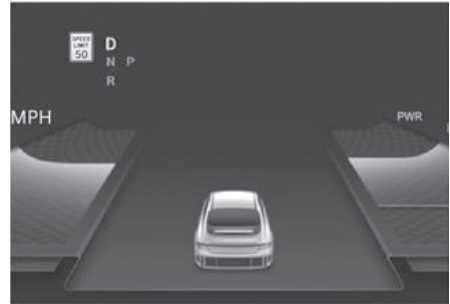

When driving at a speed higher than the displayed speed limit, the speed limit is displayed in red.

## Changing set speed



If the speed limit of the road changes during the operation of Manual Speed Limit Assist or Smart Cruise Control, an arrow in the direction of up or down is displayed to inform the driver that the set speed needs to be changed. At this time, the driver can change the set speed according to the speed limit by using the + or - switch on the steering wheel.

### Set Speed Auto Change

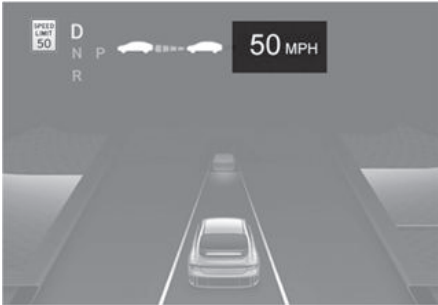

Manual Speed Limit Assist or Smart Cruise Control assists the vehicle to adjust its speed according to the speed limit. When the cruising speed is set as same as the speed limit, the vehicle automatically adjusts its speed if the speed limit changes. The function operates on the road which has a speed limit of 44 mph (70 km/h) or higher. When the function is active, the cruising speed on the instrument cluster appears in green.

### WARNING

- If you want to drive below the speed limit, adjust the Offset under **O** or use the - switch on the steering wheel to lower the set speed.
- Even after changing the set speed according to the speed limit of the road, the vehicle can still be driven over the speed limit. If necessary, depress the brake pedal to reduce your driving speed.
- If the speed limit of the road is under 20 mph (30 km/h), the set speed change function will not work.
- Intelligent Speed Limit Assist operates using the speed units in the instrument cluster set by the driver. If the speed unit is not set to the speed unit used in your state, Intelligent Speed Limit Assist may not operate properly.



### Information

- For more information on Manual Speed Limit Assist operation, refer to the “Manual Speed Limit Assist (MSLA)” section in this chapter.
- For more information on Smart Cruise Control operation, refer to the “Smart Cruise Control (SCC)” section in this chapter.

## Intelligent Speed Limit Assist Malfunction and Limitations

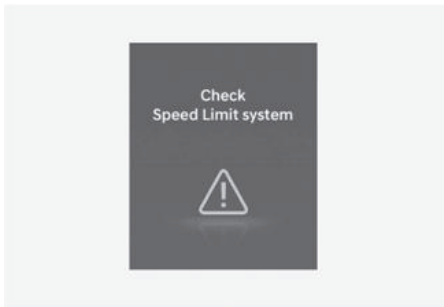
### *Intelligent Speed Limit Assist malfunction*



When Intelligent Speed Limit Assist is not working properly, the '**Check Speed Limit system**' warning message will appear on the instrument cluster for several seconds, and the master () warning light and () warning light will illuminate on the instrument cluster. If this occurs, have the vehicle inspected by an authorized HYUNDAI dealer.

## Intelligent Speed Limit Assist disabled

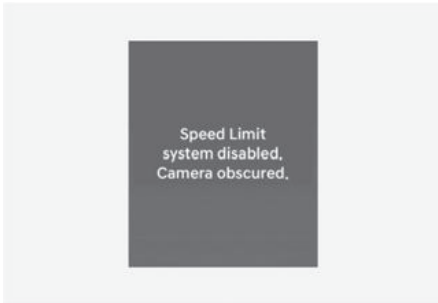

When the front windshield where the front view camera is located is covered with foreign material, such as snow or rain, it can reduce the detecting performance and temporarily limit or disable Intelligent Speed Limit Assist. If this occurs, the **'Speed Limit system disabled. Camera obscured'** warning message and (☒) warning light will appear on the instrument cluster.

Intelligent Speed Limit Assist will operate properly when snow, rain or foreign material is removed.

If Intelligent Speed Limit Assist does not operate properly after it is removed, have the vehicle inspected by an authorized HYUNDAI dealer.

### WARNING

- Even though the warning message or warning light does not appear on the instrument cluster, Intelligent Speed Limit Assist may not properly operate.
- If the vehicle is turned off and restarted while the camera is blocked or malfunctioned, the condition is maintained. Therefore, Intelligent Speed Limit Assist may not operate properly.

## Limitations of Intelligent Speed Limit Assist

Intelligent Speed Limit Assist may not operate properly, or it may operate unexpectedly under the following circumstances:

- The road sign is contaminated or indistinguishable
  - The road sign is difficult to see due to bad weather, such as rain, snow, fog, etc.
  - The road sign is not clear or damaged
  - The road sign is partially obscured by surrounding objects or shadow
- The road signs do not conform to the standard
  - The text or picture on the road sign is different from the standard
  - The road sign is installed between the main line and the exit road or between diverging roads
  - There is no conditional road signs on the road sign located on the exit road
  - A sign is attached to another vehicle
- The distance between the vehicle and the road signs is too far
- The vehicle encounters illuminant road signs
- Intelligent Speed Limit Assist incorrectly recognizes numbers or pictures in the street signs or other signs as the speed limit
- A road sign near the road you are driving is detected
- The other traffic sign or signboards are alongside the road sign
- Multiple signs are installed close together
- The minimum speed limit sign is misrecognized
- The minimum speed limit sign is on the road

- The brightness changes suddenly, for example when entering or exiting a tunnel or passing under a bridge
- Headlights are not used or the brightness of the headlights are weak at night or in the tunnel
- Road signs are difficult to recognize due to the reflection of sunlight, street lights, or oncoming vehicles
- The navigation information or GPS information contain errors.
- The driver does not follow the guide of the navigation.
- The driver is driving on a new road that is not in the navigation system yet.
- The field of view of the front view camera is obstructed by sun glare
- Driving on a road that is sharply curved or continuously curved
- Driving through speed bumps, or driving up and down or left to right on steep inclines
- The vehicle is shaking heavily
- The navigation software is being updated while driving
- The navigation is restarted while driving

### WARNING

- Intelligent Speed Limit Assist is a supplemental function that helps the driver comply with the speed limit on the road, and may not display the correct speed limit or control the driving speed properly.
  - Always set the vehicle speed to the speed limit in your area.
  - Intelligent Speed Limit Assist may not operate for 15 seconds after the vehicle is started, or the front camera is initialized.
- 

### *i* Information

For more information on the limitations of the front view camera, refer to the "Forward Collision-Avoidance Assist (FCA)" section in this chapter.

---



## Driver Attention Warning (DAW)

### ***Inattentive driving warning function***

Driver Attention Warning monitors your driving pattern while driving. When the driver's attention level is below a certain level, Driver Attention Warning recommends a break to help with safe driving.

### ***Leading vehicle departure alert function***

Leading Vehicle Departure Alert function will inform the driver when a detected vehicle in front departs.

### ***Detecting sensor***



#### (1) Front view camera

The front view camera is used as a detecting sensor to help detect driving patterns and front vehicle departure while vehicle is being driven.

Refer to the picture above for the detailed location of the detecting sensor.

#### **⚠ CAUTION**

- Always keep the front view camera in good condition to maintain optimal performance of Driver Attention Warning.
- For more information on the precautions of the front view camera, refer to the Forward Collision-Avoidance Assist (FCA) section in this chapter.

## Driver Attention Warning Settings

### Leading Vehicle Departure Alert

With the vehicle on, select or deselect **Setup > Vehicle > Driver Assistance > Driver Attention Warning** from the Settings menu to set whether to use the function.

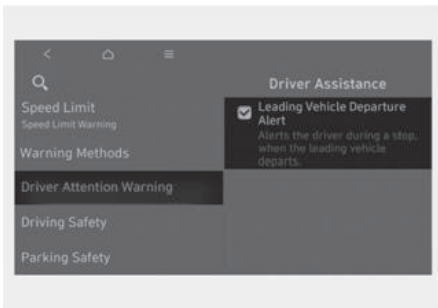

- If **Leading Vehicle Departure Alert** is selected, the function will inform the driver when a detected vehicle in front departs from a stop.

## Driver Attention Warning Operation

### Inattentive driving warning function

Driver Attention Warning is to warn the driver 'Consider taking a break'.

#### Taking a break

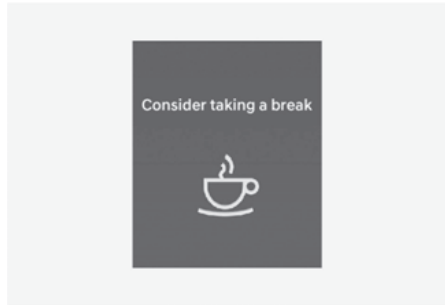

- The '**Consider taking a break**' message and Driver Attention Warning light (☹️) will appear on the instrument cluster and an audible warning will sound to suggest that the driver take a break, when the driver's attention level is below a certain level.
- Driver Attention Warning will not suggest a break when the total driving time is shorter than 4 minutes or 4 minutes has not passed after the last break was suggested.
- A break is suggested when your vehicle speed is between about 0-120 mph (0-200 km/h).

### **WARNING**

Only change the Settings after parking the vehicle at a safe location.

### ⚠ CAUTION

- Driver Attention Warning may suggest a break depending on the driver's driving pattern or habits, even if the driver doesn't feel fatigued.
- Driver Attention Warning is a supplemental function and may not be able to determine whether the driver is inattentive.
- A driver who feels fatigued should take a break at a safe location, even though there is no break suggestion by Driver Attention Warning.

### **Leading Vehicle Departure Alert function**

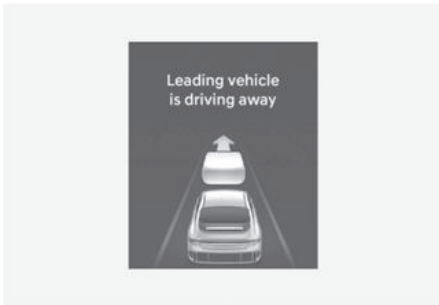

When a detected vehicle in front departs from a stop, Leading Vehicle Departure Alert will inform the driver by displaying the **'Leading vehicle is driving away'** message on the instrument cluster and an audible warning will sound.

### ⚠ WARNING

- If any other system's warning message is displayed or audible warning is generated, Leading Vehicle Departure Alert's warning message may not be displayed and audible warning may not be generated.
- The driver has the responsibility to safely drive and control the vehicle.

### ⚠ CAUTION

- Leading Vehicle Departure Alert is a supplemental function and may not alert the driver whenever the front vehicle departs from a stop.
- Always check the front of the vehicle and road conditions before departure.

### *i* Information

The images and colors in the instrument cluster may differ depending on the instrument cluster type or theme selected from the settings menu.

## Driver Attention Warning Malfunction and Limitations

### Driver Attention Warning malfunction



When Driver Attention Warning is not working properly, the '**Check Inattentive Driving Warning system**' warning message will appear on the instrument cluster for several seconds, and the master (▲) warning light and Driver Attention Warning light (☺) will illuminate on the instrument cluster. If this occurs, have the vehicle inspected by an authorized HYUNDAI dealer.

### Driver Attention Warning disabled

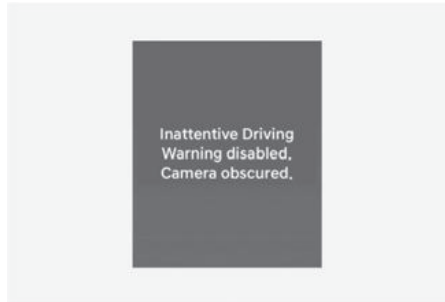

When the front windshield where the front view camera is located is covered with foreign material, such as snow or rain, it can reduce the detecting performance and temporarily limit or disable Driver Attention Warning. If this occurs, the '**Inattentive Driving Warning disabled. Camera obscured**' warning message will appear on the instrument cluster. Driver Attention Warning will operate properly when snow, rain or foreign material is removed. If Driver Attention Warning does not operate properly after it is removed, have the vehicle inspected by an authorized HYUNDAI dealer.

### WARNING

- Driver Attention Warning may not properly operate in an area (for example, open terrain) where any objects are not detected right after turning ON the vehicle.
- If the vehicle is turned off and restarted while the camera is blocked or malfunctioned, the condition is maintained. Therefore, Driver Attention Warning may not operate properly.

### Limitations of Driver Attention Warning

Driver Attention Warning may not work properly in the following situations:

- The vehicle is driven violently
- The vehicle intentionally crosses over lanes frequently
- The vehicle is controlled by Driver Assistance system, such as Lane Keeping Assist

### Leading Vehicle Departure Alert function

- When the vehicle cuts in

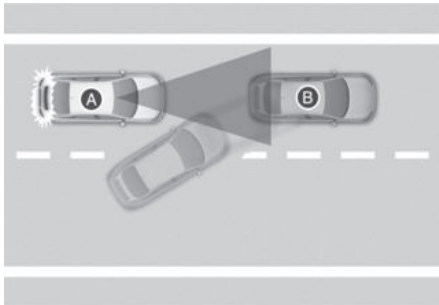
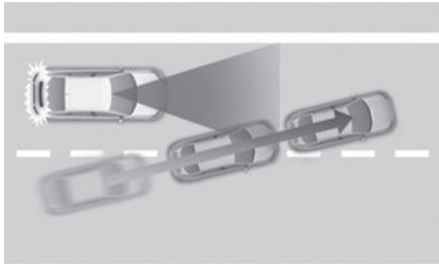

[A] Your vehicle  
[B] Front vehicle

If a vehicle cuts in front of your vehicle, Leading Departure Alert may not operate properly.

- When the vehicle ahead sharply steers

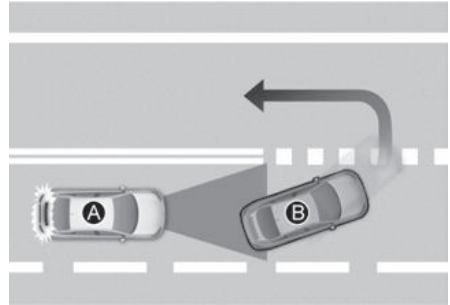

[A] Your vehicle  
[B] Front vehicle

If the vehicle in front makes a sharp turn, such as to turn left or right or make a U- turn, etc., Leading Vehicle Departure Alert may not operate properly.

- When the vehicle ahead abruptly departs

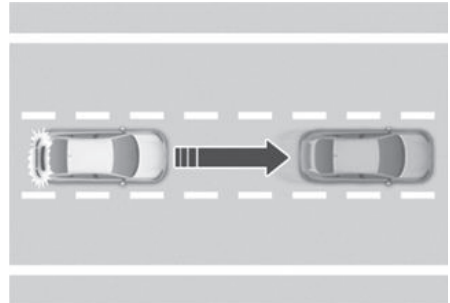

If the vehicle in front abruptly departs, Leading Vehicle Departure Alert may not operate properly.

- When a pedestrian or bicycle is between you and the vehicle ahead



If there is a pedestrian(s) or bicycle(s) in between you and the vehicle in front, Leading Vehicle Departure Alert may not operate properly.

- When in a parking lot

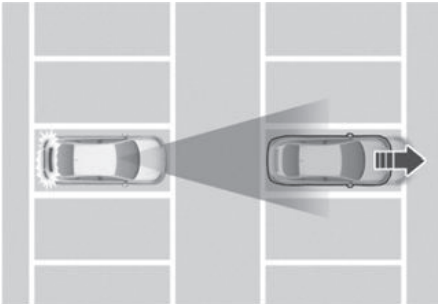

If a vehicle parked in front drives away from you, Leading Vehicle Departure Alert may alert you that the parked vehicle is driving away.

- When driving at a tollbooth or intersection, etc.

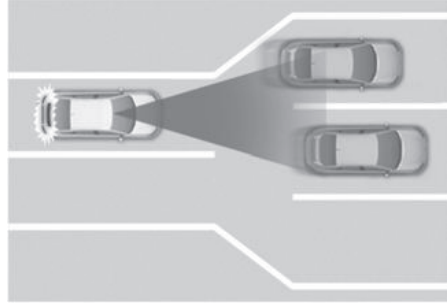

If you pass a tollbooth or intersection with lots of vehicles or you drive where lanes are merged or divided frequently, Leading Vehicle Departure Alert may not operate properly.

### **WARNING**

Driver Attention Warning may not operate for 15 seconds after the vehicle is started, or the front view camera is initialized.

### **Information**

For more information on the precautions of the front view camera, refer to the “Forward Collision-Avoidance Assist (FCA)” section in this chapter.

## Blind-Spot View Monitor (BVM)

 if equipped

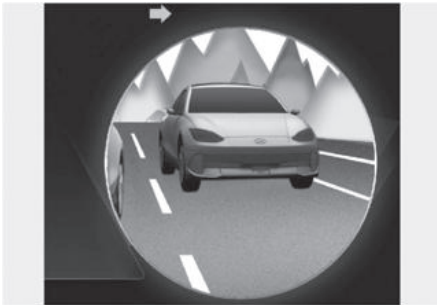

Blind-Spot View Monitor uses the wide-side view cameras to display the rear blind spot areas of your vehicle on the instrument cluster when the turn signal is turned on to help with safe lane changes.

### Detecting sensor

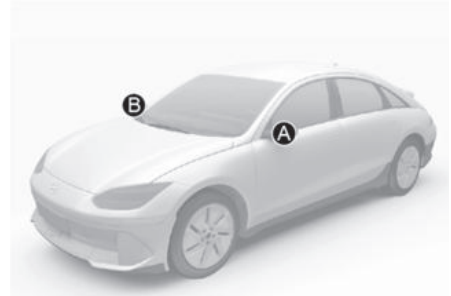

[A] Wide-side view camera (camera located at bottom of the mirror)

[B] Wide-side view camera (camera located at bottom of the mirror)

Refer to the picture above for the detailed location of the detecting sensors.

## Blind-Spot View Monitor Settings

### Setting features

#### Blind-Spot View

With the vehicle on, select **Setup > Vehicle > Driver Assistance > Driving Safety > Blind-Spot View Monitor** from the Settings menu to turn on Blind-Spot View Monitor and deselect to turn off the function.

## Blind-Spot View Monitor Operation

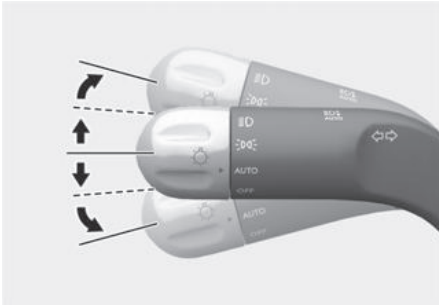

Blind-Spot View Monitor will turn on and off when the turn signal is turned on and off.

### **Operating conditions**

When the left or right side turn signal turns on, the image in that direction is displayed on the instrument cluster.

### **Off conditions**

- When the turn signal turns off, the image on the instrument cluster will turn off.
- When the hazard warning flasher is on, Blind-Spot View Monitor will turn off, regardless of the turn signal status.
- When other important warning is displayed on the instrument cluster, Blind-Spot View Monitor may turn off.

## Blind-Spot View Monitor Malfunction

When Blind-Spot View Monitor is not working properly, or the cluster display flickers, or the camera image does not display properly, have the vehicle inspected by an authorized HYUNDAI dealer.

### **! WARNING**

- The image shown on the instrument cluster may differ from the actual distance of the object. Make sure to directly check the vehicle's surroundings for safety.
- Always keep the camera lens clean. If the lens is covered with foreign material, it may adversely affect camera performance and Blind-Spot View Monitor may not operate properly.



## Smart Cruise Control (SCC)

Smart Cruise Control detects a vehicle ahead and helps maintain the distance from the vehicle ahead and the set speed.

### **Overtaking Acceleration Assist**

When Smart Cruise Control judges you are attempting to overtake a vehicle in front, Smart Cruise Control help with accelerating.

### **Based on Driving Style**

**+** if equipped

Smart Cruise Control operates based on your driving style, such as vehicle distance, acceleration, and reaction speed.

### **Detecting sensor**

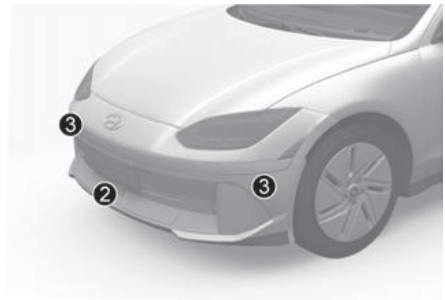

- (1) Front view camera,
- (2) Front radar,
- (3) Front corner radar (if equipped)

The front view camera and front radar are used as a detecting sensor to detect front vehicles.

Refer to the picture above for the detailed location of the detecting sensor.

### **⚠ CAUTION**

Always keep the front view camera and front radar in good condition to maintain optimal performance of Smart Cruise Control.

For more information on the precautions of the front view camera and front radar, refer to the "Forward Collision-Avoidance Assist (FCA)" section in this chapter.

## Smart Cruise Control Settings

### Smart Cruise Control

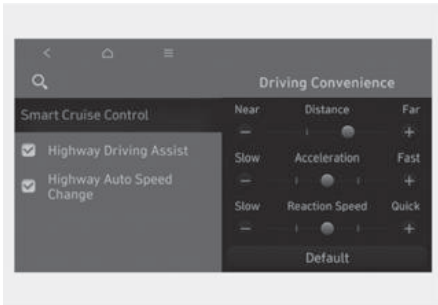

With the vehicle on, select **Setup > Vehicle > Driver Assistance > Driving Convenience > Smart Cruise Control** from the settings menu to change Distance, Acceleration and Reaction Speed manually.

### Based on Driving Style

**if equipped**

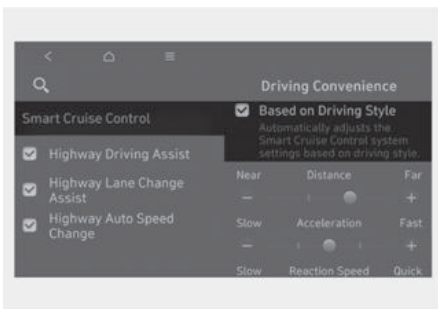

With the vehicle on, if **Setup > Vehicle > Driver Assistance > Driving Convenience > Smart Cruise Control > Based on Driving Style** is selected from the Settings menu, Smart Cruise Control will operate based on the driver's driving style, such as vehicle distance, acceleration, reaction speed.

## i Information

- If the **Based on Driving Style** is supported, you can select it from the **Setup > Vehicle > Driver Assistance > Driving Convenience > Smart Cruise Control**.
- Based on driving style setting continuously learns when the driver drives the vehicle.
- When Based on driving style is deactivated, the driver's driving style such as vehicle distance, acceleration, reaction speed will maintain in the same stage.

## Warning Methods

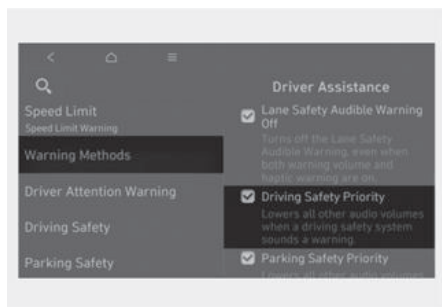
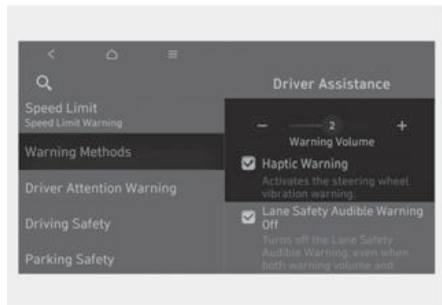

With the vehicle on, go to **Setup > Vehicle > Driver Assistance > Warning Methods** from the Settings in the infotainment system to select the following:

- **Warning Volume:** The Warning Volume can be adjusted.  
If you turn off the **Warning Volume**, for your safety, the function may warn you with a low volume.
- **Haptic Warning:** The steering wheel vibration can be set.
- **Driving Safety Priority:** Your vehicle lowers all other audio volumes when the Driver Assistance system warning sounds.

### *i* Information

- If the vehicle is restarted, Warning Volume will maintain the last setting.
- If the vehicle is restarted, Warning Methods will maintain the last setting.
- There may be no Settings menu depending on the feature applied to your vehicle.
- The **Warning Volume** and **Haptic Warning** cannot be turned off at the same time. When one of the warnings is turned off, the other is activated.

## Smart Cruise Control Operation

### *Operating conditions*

#### Basic function

Smart Cruise Control operates when the following conditions are satisfied.

- The gear is in D (Drive)
- The driver's door is closed
- EPB (Electronic Parking Brake) is not applied
- Your vehicle speed is within the operating speed range
  - 5-110 mph (10-180 km/h): when there is no vehicle in front
  - 0-110 mph (0-180 km/h): when there is a vehicle in front
- ESC (Electronic Stability Control) or ABS (Anti-Lock Braking System) is on

Smart Cruise Control does not operate in the following conditions.

- The driver's door is opened
- Your vehicle is in power down mode (⊖)
- EPB (Electronic Parking Brake) is applied
- ESC (Electronic Stability Control) or ABS (Anti-Lock Braking System) is controlling the vehicle
- Forward Collision-Avoidance Assist brake control is operating
- Remote Smart Parking Assist brake control is operating (if equipped)

### *i* Information

When stopped behind another vehicle, the driver can turn on Smart Cruise Control while the brake pedal is depressed.

### Operating conditions for Acceleration Assist

Overtaking Acceleration Assist operates when the turn signal indicator is turned on to the left while Smart Cruise Control is operating, and the following conditions are satisfied:

- Your vehicle speed is above 40 mph (60 km/h)
- A vehicle is detected in front of your vehicle

Overtaking Acceleration Assist does not operate in the following conditions.

- The hazard warning flasher is on
- Vehicle speed is reduced to maintain distance with the vehicle in front

### **WARNING**

- When the turn signal indicator is turned on to the left while there is a vehicle ahead, the vehicle may accelerate temporarily. Pay attention to the road conditions at all times.
- 

### Turning on Smart Cruise Control



- Press the Driving Assist button to turn on Smart Cruise Control. The speed will be set to the current speed on the instrument cluster.
- If there is no vehicle in front of you, the set speed will be maintained, but if there is a vehicle in front of you, the speed may decrease to maintain the distance to the vehicle ahead. If the vehicle ahead accelerates, your vehicle will travel at a steady cruising speed after accelerating to the set speed.

### **Information**

If your vehicle speed is between 0-20 mph (0-30 km/h) when you press the Driving Assist button, Smart Cruise Control speed will be set to 20 mph (30 km/h).

---

### Setting vehicle distance

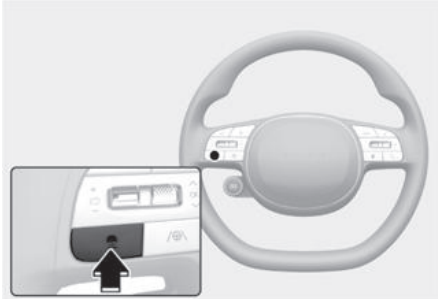

Each time the button is pressed, the headway changes as follows:

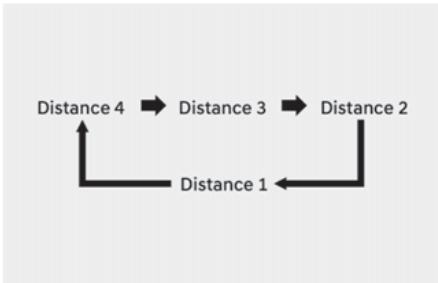

#### **i** Information

- If you drive at 56 mph (90 km/h), the distance is maintained as follows:  
 Distance 4 - about 172 ft. (53 m)  
 Distance 3 - about 130 ft. (40 m)  
 Distance 2 - about 106 ft. (30 m)  
 Distance 1 - about 82 ft. (25 m)
- The distance is set to the last set distance when the vehicle is restarted, or when Smart Cruise Control was temporarily canceled.

### Increasing set speed

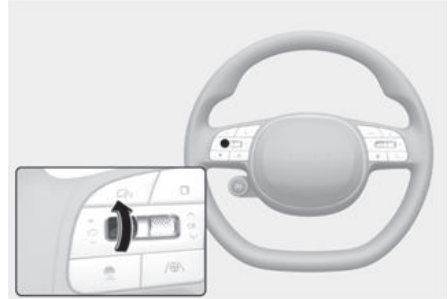

- Push the + switch up and release it immediately. The set speed will increase by 1 mph (1 km/h) each time the switch is operated in this manner.
- Push the + switch up and hold it while monitoring the set speed on the instrument cluster. The set speed will increase by 5 mph (10 km/h) each time the switch is operated in this manner. Release the switch when the desired speed is shown, and the vehicle will accelerate to that speed. You can increase the set speed to 110 mph (180 km/h).

#### **!** WARNING

Check the driving condition before using the + switch. Driving speed may sharply increase when you push up and hold the + switch.

### Decreasing set speed

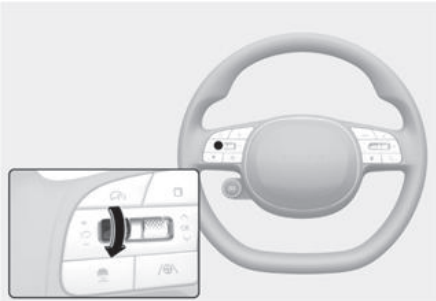

- Push the - switch down and release it immediately. The set speed will decrease by 1 mph (1 km/h) each time the switch is operated in this manner.
- Push the - switch down and hold it while monitoring the set speed on the instrument cluster. The set speed will decrease by 5 mph (10 km/h) each time the switch is operated in this manner. Release the switch at the speed you want to maintain. You can decrease the set speed to 20 mph (30 km/h).

### Temporarily canceling Smart Cruise Control

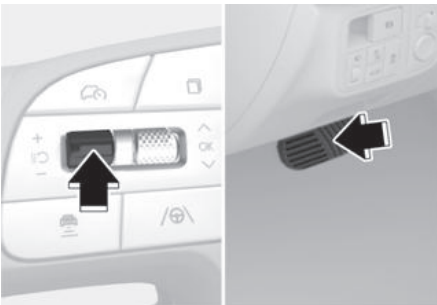

Press the || switch or depress the brake pedal to temporarily cancel Smart Cruise Control.

### Resuming Smart Cruise Control

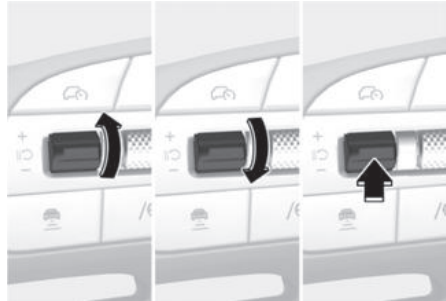

To resume Smart Cruise Control after the function was canceled, operate the +, - or || switch.

If you push the + switch up or - switch down, vehicle speed will be set to the current speed on the instrument cluster.

If you press the || switch, vehicle speed will resume to the preset speed.

### WARNING

Check the driving condition before using the || switch. Driving speed may sharply increase or decrease when you press the || switch.

## Turning off Smart Cruise Control



Press the Driving Assist (🚗➡️) button to turn Smart Cruise Control off.

### **i** Information

If your vehicle is equipped with Manual Speed Limit Assist, press and hold the Driving Assist (🚗➡️) button to turn off Smart Cruise Control. However Manual Speed Limit Assist will turn on.

### **⚠️** WARNING

Do not use the switches and buttons at the same time. Smart Cruise Control may not operate properly.

## Display and Control

### Basic function

You can see the status of the Smart Cruise Control operation in the Driving Assist view on the instrument cluster. For more information, refer to the "View Modes" section in chapter 4.

Smart Cruise Control will be displayed as below depending on the status of the function.

Operating



Temporarily canceled



- When operating
  1. Whether there is a vehicle ahead and the selected distance level
  2. Set speed
  3. Whether there is a vehicle ahead and the target vehicle distance

- When temporarily canceled
  1. Your vehicle (grey)
  2. Previous set speed (grey)
  3. Vehicle ahead and distance level (grey) (if equipped)

### **i** Information

- The distance of the front vehicle on the instrument cluster is displayed based on the actual distance between your vehicle and the vehicle ahead.
  - The target distance may vary according to the vehicle speed and the set distance level. If the vehicle speed is low, even though the vehicle distance have changed, the change of the target vehicle distance may be small.
  - The images and colors in the instrument cluster may differ depending on the instrument cluster type or theme selected from the settings menu.
- 

### Accelerating temporarily



If you want to speed up temporarily without altering the set speed while Smart Cruise Control is operating, depress the accelerator pedal. While the accelerator pedal is depressed, the set speed, distance level and target distance will blink on the instrument cluster. However, if the accelerator pedal is depressed insufficiently, the vehicle may decelerate.

### **!** WARNING

Be careful when accelerating temporarily, because the speed and distance is not controlled automatically even if there is a vehicle in front of you.

---



### Based on Driving Style operation



When Based on driving style is operating, the vehicle distance level and target distance will be displayed white based on the driving style.

#### CAUTION

- The vehicle must be driven sufficiently to reflect the actual driver's driving style to the Based on Driving Style's vehicle distance, acceleration, and reaction speed.
- Based on Driving Style may not reflect driving styles or driving conditions that affect safe driving.
- If you are driving in special conditions, such as snow, rain, fog, or steep slopes, the vehicle may not be driven according to the driver's driving style.

#### Information

- Driving styles that are far from safe driving such as sudden acceleration may not be reflected to Based on Driving Style.
- Based on Driving Style does not reflect any other driving style other than vehicle distance, acceleration and reaction speed.

### Temporarily canceling Smart Cruise Control

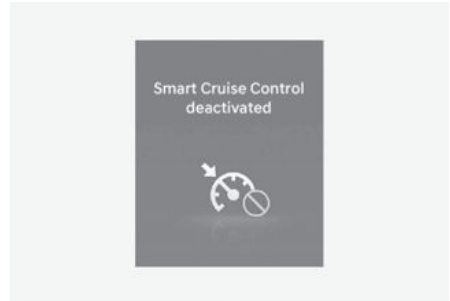

- The vehicle speed is above 120 mph (190 km/h)
- The vehicle is stopped for a certain period of time
- The accelerator pedal is continuously depressed for a certain period of time
- The conditions for the Smart Cruise Control to operate is not satisfied

If Smart Cruise Control is temporarily canceled automatically, the **'Smart Cruise Control deactivated'** warning message will appear on the instrument cluster, and an audible warning will sound to warn the driver.

#### Information

If Smart Cruise Control is temporarily canceled while the vehicle is at a standstill with the function activated, EPB (Electronic Parking Brake) maybe applied.

#### WARNING

When Smart Cruise Control is temporarily canceled, distance with the front vehicle will not be maintained. Always have your eyes on the road while driving, and if necessary, depress the brake pedal to reduce your driving speed in order to maintain a safe distance.

### Smart Cruise Control conditions not satisfied

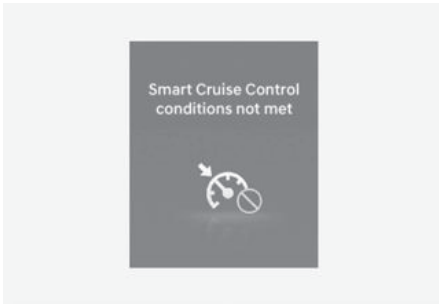

If the Driving Assist button, + switch, - switch or  switch is operated when Smart Cruise Control operating conditions are not satisfied, the **'Smart Cruise Control conditions not met'** will appear on the instrument cluster, and an audible warning will sound.

### In traffic situation

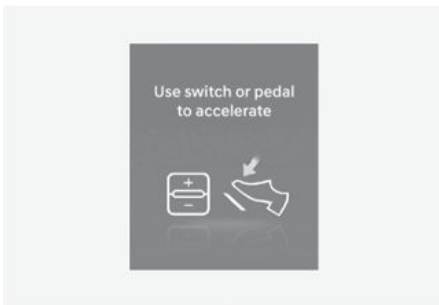

In traffic, your vehicle will stop if the vehicle ahead of you stops. Also, if the vehicle ahead of you starts moving, your vehicle will start as well. In addition, after the vehicle has stopped and a certain time have passed, the **'Use switch or pedal to accelerate'** message will appear on the instrument cluster. Depress the accelerator pedal or operate the + switch, - switch or  switch to start driving.

### Warning road conditions ahead

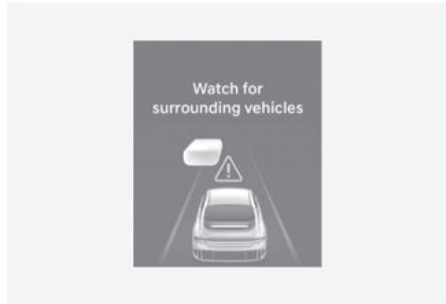

In the following situation, the **'Watch for surrounding vehicles'** warning message will appear on the instrument cluster, and an audible warning will sound to warn the driver of road conditions ahead.

- The vehicle in front disappears when Smart Cruise Control is maintaining the distance with the vehicle ahead while driving below a certain speed.

### WARNING

Always pay attention to vehicles or objects that may suddenly appear in front of you, and if necessary, depress the brake pedal to reduce your driving speed in order to maintain a safe distance.

## Collision Warning



While Smart Cruise Control is operating, when the collision risk with the vehicle ahead is high, the **'Collision Warning'** warning message will appear on the instrument cluster, and an audible warning will sound to warn the driver. Always have your eyes on the road while driving, and if necessary, depress the brake pedal to reduce your driving speed in order to maintain a safe distance.

### WARNING

In the following situations, Smart Cruise Control may not warn the driver of a collision.

- The distance from the front vehicle is near, or the vehicle speed of the front vehicle is faster or similar with your vehicle
- The speed of the front vehicle is very slow or is at a standstill
- The accelerator pedal is depressed right after Smart Cruise Control is turned on

### WARNING

Take the following precautions when using Smart Cruise Control:

- Smart Cruise Control does not substitute for proper and safe driving. It is the responsibility of the driver to always check the speed and distance to the vehicle ahead.
- Smart Cruise Control may not recognize unexpected and sudden situations or complex driving situations, so always pay attention to driving conditions and control your vehicle speed.
- Keep Smart Cruise Control off when the function is not in use to avoid inadvertently setting a speed.
- Do not open the door or leave the vehicle when Smart Cruise Control is operating, even if the vehicle is stopped.
- Always be aware of the selected speed and headway distance.
- Keep a safe distance according to road conditions and vehicle speed. If the headway distance is too close during high-speed driving, a serious collision may result.
- When maintaining distance with the vehicle ahead, if the front vehicle disappears, Smart Cruise Control may suddenly accelerate to the set speed. Always be aware of unexpected and sudden situations from occurring.
- Vehicle speed may decrease on an upward slope and increase on a downward slope.
- Always be aware of situations such as when a vehicle cuts in suddenly.
- When you are towing a trailer or another vehicle, turn off Smart Cruise Control for safety reasons.
- Turn off Smart Cruise Control when your vehicle is being towed.

- Smart Cruise Control may not operate properly if interfered by strong electromagnetic waves.
- Smart Cruise Control may not detect an obstacle in front and lead to a collision. Always look ahead cautiously to prevent unexpected and sudden situations from occurring.
- Vehicles moving in front of you with a frequent lane change may cause a delay in Smart Cruise Control reaction or may cause Smart Cruise Control to react to a vehicle actually in an adjacent lane. Always drive cautiously to prevent unexpected and sudden situations from occurring.
- Always be aware of the surroundings and drive safely, even though a warning message does not appear or an audible warning does not sound.
- If any other system's warning message is displayed or warning sound is generated, Smart Cruise Control warning message may not be displayed and warning sound may not be generated.
- You may not hear the warning sound of Forward Collision-Avoidance Assist if the surrounding is noisy.
- The vehicle manufacturer is not responsible for any traffic violation or accidents caused by the driver.
- Always set the vehicle speed under the speed limit in your area.
- Vehicle distance, acceleration and reaction speed may change if the driver's driving style changes.

### **i** Information

- Smart Cruise Control may not operate for 15 seconds after the vehicle is started or the front view camera or front radar is initialized.
- You may hear a sound when the brake is controlled by Smart Cruise Control.

## Smart Cruise Control Malfunction and Limitations

### **Smart Cruise Control malfunction**

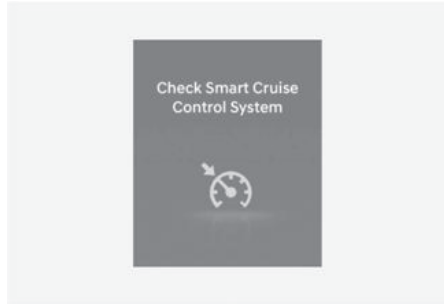

When Smart Cruise Control is not working properly, the '**Check Smart Cruise Control System**' warning message will appear, and the (Δ) warning light will illuminate on the instrument cluster. Have the vehicle inspected by an authorized HYUNDAI dealer.

### **Smart Cruise Control disabled**

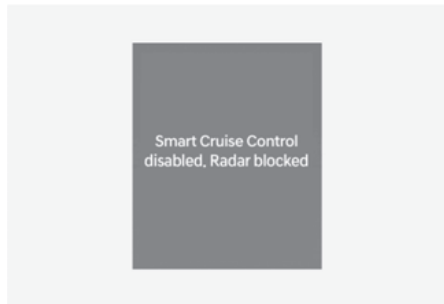

When the front radar cover or sensor is covered with snow, rain, or foreign material, it can reduce the detecting performance and temporarily limit or disable Smart Cruise Control.

If this occurs the '**Smart Cruise Control disabled, Radar blocked**' warning message will appear for a certain period of time on the instrument cluster.

Smart Cruise Control will operate properly when snow, rain or foreign material is removed.

### WARNING

Even though the warning message does not appear on the instrument cluster, Smart Cruise Control may not properly operate.

### CAUTION

Smart Cruise Control may not properly operate in an area (for example, open terrain), where there is nothing to detect after turning ON the vehicle.

### ***Limitations of Smart Cruise Control***

Smart Cruise Control may not operate properly, or it may operate unexpectedly under the following circumstances:

- The detecting sensor or the surroundings are contaminated or damaged
- Washer fluid is continuously sprayed, or the wiper is on
- The camera lens is contaminated due to tinted, filmed or coated windshield, damaged glass, or sticky foreign material (sticker, bug, etc.) on the glass
- Moisture is not removed or frozen on the windshield
- The field of view of the front view camera is obstructed by sun glare
- Street light or light from an oncoming vehicle is reflected on the wet road surface, such as a puddle on the road
- The temperature around the front view camera is high or low
- An object is placed on the dashboard
- The surrounding is very bright
- The surrounding is very dark, such as in a tunnel, etc.
- The brightness changes suddenly, for example when entering or exiting a tunnel
- The brightness outside is low, and the headlights are not on or are not bright
- Driving in heavy rain or snow, or thick fog
- Driving through steam, smoke or shadow
- Only part of the vehicle is detected
- The vehicle in front has no tail lights, tail lights are located unusually, etc.
- The brightness outside is low, and the tail lights are not on or are not bright
- The rear of the front vehicle is small or does not look normal (for example, tilted, overturned, etc.)
- The front vehicle's ground clearance is low or high
- A vehicle suddenly cuts in front
- Your vehicle is being towed
- Driving through a tunnel or iron bridge
- Driving near areas containing metal substances, such as a construction zone, railroad, etc.
- An object reflecting off the front radar such as a guardrail, nearby vehicle, etc.
- The bumper around the front radar is impacted, damaged or the front radar is out of position
- The temperature around the front radar is high or low
- Driving in vast areas where there are few vehicles or structures (for example, desert, meadow, suburb, etc.)
- The vehicle in front is made of material that does not reflect on the front radar
- Driving near a highway interchange or tollbooth
- Driving on a slippery surface due to snow, water puddle, ice, etc.
- Driving on a curved road
- The vehicle in front is detected late

- The vehicle in front is suddenly blocked by an obstacle
- The vehicle in front suddenly changes lane or suddenly reduces speed
- The vehicle in front is bent out of shape
- The front vehicle's speed is fast or slow
- With a vehicle in front, your vehicle changes lane at low speed
- The vehicle in front is covered with snow
- Unstable driving
- You are on a roundabout and the vehicle in front is not detected
- You are continuously driving in a circle
- Driving in a parking lot
- Driving through a construction area, unpaved road, partial paved road, uneven road, speed bumps, etc.
- Driving on an incline road, curved road, etc.
- Driving through a roadside with trees or streetlights
- The adverse road conditions cause excessive vehicle vibrations while driving
- Your vehicle height is low or high due to heavy loads, abnormal tire pressure, etc.
- Driving through a narrow road where trees or grass are overgrown
- There is interference by electromagnetic waves, such as driving in an area with strong radio waves or electrical noise

- Driving on a curved road



On curves, Smart Cruise Control may not detect a vehicle in the same lane, and may accelerate to the set speed. Also, vehicle speed may rapidly decrease when the vehicle ahead is detected suddenly.

Select the appropriate set speed on curves and apply the brake pedal or accelerator pedal according to the road and driving conditions ahead.

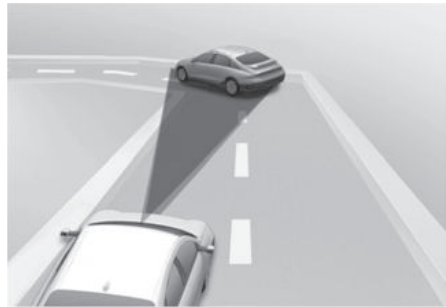

Your vehicle speed can be reduced due to a vehicle in the adjacent lane.

Apply the accelerator pedal and select the appropriate set speed. Check to be sure that the road conditions permit safe operation of the Smart Cruise Control.

- Driving on an inclined road

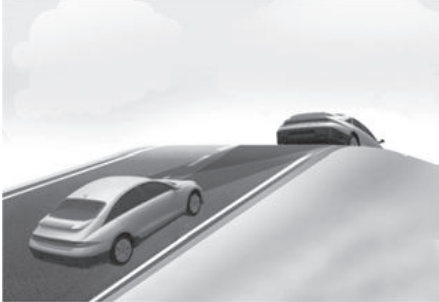

During uphill or downhill driving, the Smart Cruise Control may not detect a moving vehicle in your lane, and cause your vehicle to accelerate to the set speed. Also, vehicle speed will rapidly decrease when the vehicle ahead is detected suddenly.

Select the appropriate set speed on inclines and apply the brake pedal or accelerator pedal according to the road and driving conditions ahead.

- Changing lanes



- [A] Your vehicle  
[B] Lane changing vehicle

When a vehicle moves into your lane from an adjacent lane, it cannot be detected by the sensor until it is in the sensor's detection range. Smart Cruise Control may not immediately detect the vehicle when the vehicle changes lanes abruptly. In this case, you must maintain a safe braking distance, and if necessary, depress the brake pedal to reduce your driving speed in order to maintain a safe distance.

- Situations when detecting are limited

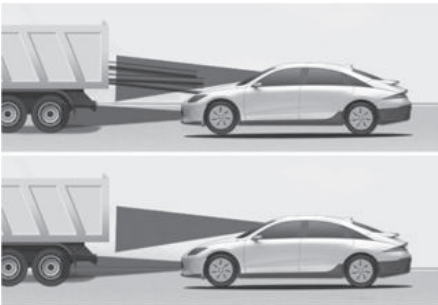
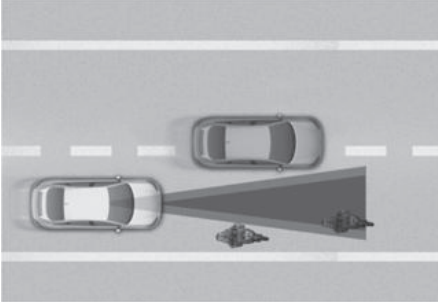

In the following cases, some vehicles, pedestrians or animals in your lane cannot be detected by the sensor:

- Vehicles offset to one side
- Slow-moving vehicles or sudden decelerating vehicles
- Vehicles with higher ground clearance or vehicles carrying loads that stick out of the back of the vehicle
- Vehicles that has the front lifted due to heavy loads
- Vehicles within about 6 ft. (2 m) from your vehicle
- Oncoming vehicles
- Stopped vehicles
- Vehicles with small rear profile, such as trailers

- Narrow vehicles, such as motorcycles or bicycles

- Special vehicles
- Animals and pedestrians

Adjust your vehicle speed by depressing the brake pedal according to the road and driving conditions ahead.

In the following cases, the vehicle in front cannot be detected by the sensor:

- You are steering your vehicle
- Driving on narrow or sharply curved roads

Adjust your vehicle speed by depressing the brake pedal according to the road and driving conditions ahead.

- When a vehicle ahead disappears at an intersection, your vehicle may accelerate.

Always pay attention to road and driving conditions while driving.

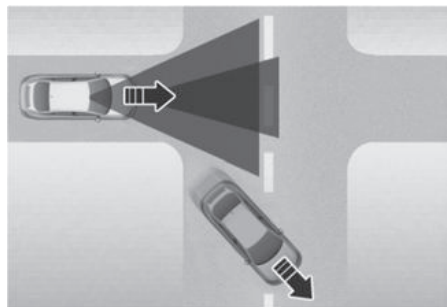



- When a vehicle in front of you merges out of the lane, Smart Cruise Control may not immediately detect the new vehicle that is now in front of you.

Always pay attention to road and driving conditions while driving.

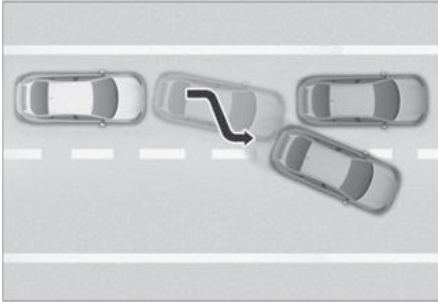

- Always look out for pedestrians when your vehicle is maintaining a distance with the vehicle ahead.

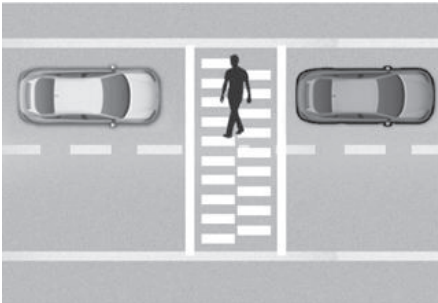

### *i* Information

This device complies with Part 15 of the FCC rules.

Operation is subject to the following three conditions:

1. This device may not cause harmful interference, and
2. This device must accept any interference received, including interference that may cause undesired operation.
3. Changes or modifications not expressly approved by the party responsible for compliance could void the user's authority to operate the device.

### *i* Information

Radio frequency radiation exposure information:

This equipment complies with FCC radiation exposure limits set forth for an uncontrolled environment.

This equipment should be installed and operated with minimum distance of 8 in. (20 cm) between the radiator (antenna) and your body.

This transmitter must not be co-located or operating in conjunction with any other antenna or transmitter.

## Navigation-Based Smart Cruise Control (NSCC)

 If equipped

Navigation-based Smart Cruise Control helps maintain safe speed depending on the road conditions by using information from the navigation system when driving on highways while Smart Cruise Control is operating.

### *i* Information

- Navigation-based Smart Cruise Control is available only on controlled access road of certain highways.
  - Controlled access road indicates roads with limited entrances and exits that allow uninterrupted high speed traffic flow. Only passenger cars and motorcycles are allowed on controlled access roads.
- Additional highways may be expanded by future navigation updates.

#### Available Highway (Controlled access road)

USA	Select Interstate Highway and U.S. (Federal) and State Highways
Canada	Select Provincial and Territorial Highways

### *i* Information

Navigation-based Smart Cruise Control operates on main roads of highways, and does not operate on interchanges or junctions.

## Highway Curve Zone Auto Slowdown

If vehicle speed is high, Highway Curve Zone Auto Slowdown function will temporarily decelerate your vehicle or limit acceleration to help you drive safely on a curve based on the curve information from the navigation.

## Navigation-based Smart Cruise Control Settings

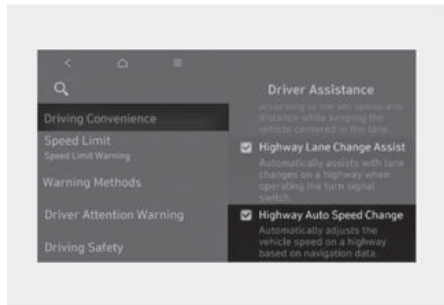

With the vehicle on, select **Setup > Vehicle > Driver Assistance > Driving Convenience > Highway Auto Speed Change** from the Settings menu to turn on Navigation-based Smart Cruise Control and deselect to turn off the function.

### *i* Information

When there is a problem with Navigation-based Smart Cruise Control, the function cannot be set from the Settings menu.

## Navigation-based Smart Cruise Control Operation

### Operating conditions

Navigation-based Smart Cruise Control is ready to operate if all of the following conditions are satisfied:

- Select "**Highway Auto Speed Change**" from the infotainment system.
- Smart Cruise Control is operating
- Driving on main roads of highways

### *i* Information

For more information on how to operate Smart Cruise Control, refer to the "Smart Cruise Control (SCC)" section in this chapter.

### Navigation-based Smart Cruise Control display and control

When Navigation-based Smart Cruise Control operates, it will be displayed on the instrument cluster as follows:



#### Navigation-based Smart Cruise Control standby

If the operating conditions are satisfied, the green **NAV** indicator light illuminates.

#### Navigation-based Smart Cruise Control operating

While the speed is being controlled, the green **NAV** indicator light blinks.

#### Temporarily canceled or interrupted by the driver

If Navigation-based Smart Cruise Control cannot control the vehicle, such as when Smart Cruise Control is temporarily canceled or the navigation system is searching for a route, the gray **NAV** indicator light illuminates.

When the driver depresses the accelerator pedal, the white **NAV** indicator light blinks.

### **!** WARNING



'Drive carefully' warning message will appear in the following circumstances:

- Navigation-based Smart Cruise Control is not able to slow down your vehicle to a safe speed

### *i* Information

The images and colors in the instrument cluster may differ depending on the instrument cluster type or theme selected from the settings menu.

### Highway Curve Zone Auto Slowdown

- Depending on the curve ahead on the highway, the vehicle will decelerate, and after passing the curve, the vehicle will accelerate to Smart Cruise Control set speed.
- Vehicle deceleration time may differ depending on the vehicle speed and the degree of the curve on the road. The higher the driving speed, deceleration will start faster.

### Limitations of Navigation-based Smart Cruise Control

Navigation-based Smart Cruise Control may not operate properly under the following circumstances:

- The navigation is not working properly
- Map information is not transmitted due to infotainment system's abnormal operation
- Speed limit and road information in the navigation is not updated
- The map information and the actual road is different because of real-time GPS data or map information error
- The navigation searches for a route while driving
- GPS signals are blocked in areas such as a tunnel
- A road that divides into two or more roads and joins again
- The driver goes off course from the route set in the navigation
- The route to the destination is changed or cancelled by resetting the navigation
- The vehicle enters a service station or rest area
- Android Auto or Car Play is operating
- The navigation cannot detect the current vehicle position (for example, elevated roads including overpass

adjacent to general roads or nearby roads exist in a parallel way)

- The navigation is being updated while driving
- The navigation is being restarted while driving
- The speed limit of some sections changes according to the road situations
- Driving on a road under construction
- Driving in lane-restricted driving situations
- There is bad weather, such as heavy rain, heavy snow, etc.
- Driving on a road that is sharply curved

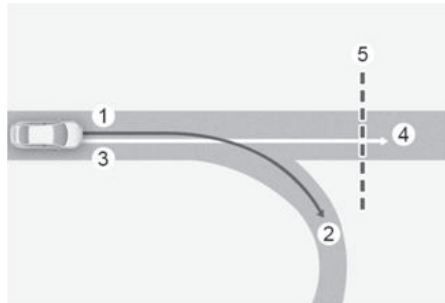

- (1) Set route,
- (2) Branch line,
- (3) Driving route,
- (4) Main road,
- (5) Curved road section

- When there is a difference between the navigation set route (branch line) and the driving route (main road), Highway Curve Zone Auto Slowdown function may not operate until the driving route is recognized as the main road.
- When the vehicle's driving route is recognized as the main road by maintaining the main road instead of the navigation set route, Highway Curve Zone Auto Slowdown function will operate. Depending on the distance to the curve and the current vehicle

speed, vehicle deceleration may not be sufficient or may decelerate rapidly.

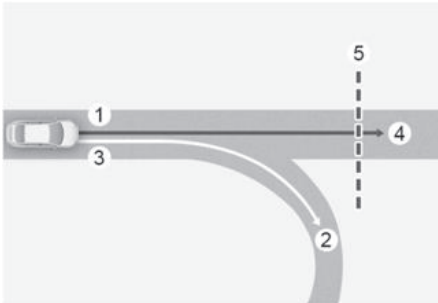

- (1) Set route,
- (2) Branch line,
- (3) Driving route,
- (4) Main road,
- (5) Curved road section

- When there is a difference between the navigation route (main road) and the driving route (branch line), Highway Curve Zone Auto Slowdown function will operate based on the curve information on the main road.
- When it is judged that you are driving out of the route by entering the highway interchange or junction, Highway Curve Zone Auto Slowdown function will not operate.

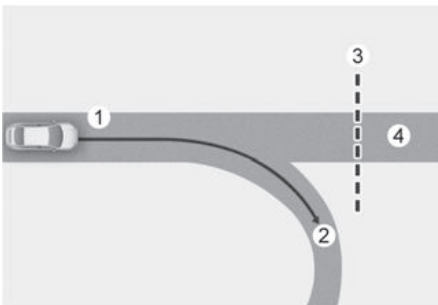

- (1) Driving route,
- (2) Branch line,
- (3) Curved road section,
- (4) Main road,

- If there is no destination set on the navigation, Highway Curve Zone Auto Slowdown function will operate based on the curve information on the main road.
- Even if you depart from the main road, Highway Curve Zone Auto Slowdown function may temporarily operate due to navigation information of the highway curve section.

### **⚠ WARNING**

- Navigation-based Smart Cruise Control is not a substitute for safe driving practices, but a convenience function. Always have your eyes on the road, and it is the responsibility of the driver to avoid violating traffic laws.
- The navigation's speed limit information may differ from the actual speed limit information on the road. It is the driver's responsibility to check the speed limit on the actual driving road or lane.
- Navigation-based Smart Cruise Control will automatically be canceled when you leave the highway main road. Always pay attention to road and driving conditions while driving.
- Navigation-based Smart Cruise Control may not operate due to the existence of leading vehicles and the driving conditions of the vehicle. Always pay attention to road and driving conditions while driving.
- When you are towing a trailer or another vehicle, turn off Navigation-based Smart Cruise Control for safety reasons.
- After you pass through a tollbooth on a highway, Navigation-based Smart Cruise Control will operate based on the first lane. If you enter one of the other lanes, Navigation-based Smart Cruise Control might not operate properly.

- The vehicle will accelerate if the driver depresses the accelerator pedal while Navigation-based Smart Cruise Control is operating, and the function will not decelerate the vehicle. However, if the accelerator pedal is depressed insufficiently, the vehicle may decelerate.
  - If the driver accelerates and releases the accelerator pedal while Navigation-based Smart Cruise Control is operating, the vehicle may not decelerate sufficiently or may rapidly decelerate to a safe speed.
  - If the curve is too large or too small, Navigation-based Smart Cruise Control may not operate.
- 

### *i* Information

- A time gap could occur between the navigation's guidance and when Navigation-based Smart Cruise Control operation starts and ends.
  - The speed information on the instrument cluster and navigation may differ.
  - Even if you are driving at a speed lower than Smart Cruise Control set speed, acceleration may be limited by the curve sections ahead.
  - If Navigation-based Smart Cruise Control is operating while leaving the main road to enter an interchange, junction, rest area, etc., the function may operate for a certain period of time.
  - Deceleration by Navigation-based Smart Cruise Control may feel it is not sufficient due to road conditions such as uneven road surfaces, narrow lanes, etc.
- 

### *i* Information

This device complies with Part 15 of the FCC rules.

Operation is subject to the following three conditions:

1. This device may not cause harmful interference, and
  2. This device must accept any interference received, including interference that may cause undesired operation.
  3. Changes or modifications not expressly approved by the party responsible for compliance could void the user's authority to operate the device.
- 

### *i* Information

Radio frequency radiation exposure information:

This equipment complies with FCC radiation exposure limits set forth for an uncontrolled environment.

This equipment should be installed and operated with minimum distance of 8 in. (20 cm) between the radiator (antenna) and your body.

This transmitter must not be co-located or operating in conjunction with any other antenna or transmitter.

---

## Lane Following Assist (LFA)

Lane Following Assist detects lane markings and/or a vehicle ahead on the road, and center your vehicle in the lane.

### Detecting sensor



#### (1) Front view camera

The front view camera is used as a detecting sensor to detect lane markings and front vehicles.

Refer to the picture above for the detailed location of the detecting sensor.

### CAUTION

For more information on the precautions of the front view camera, refer to the "Forward Collision-Avoidance Assist (FCA)" section in this chapter.

## Lane Following Assist Settings

### Warning Methods

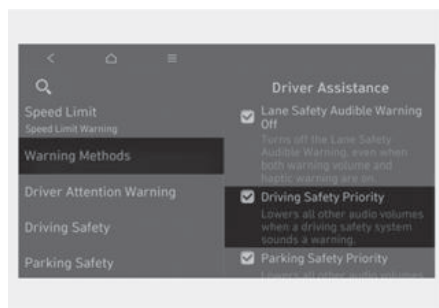
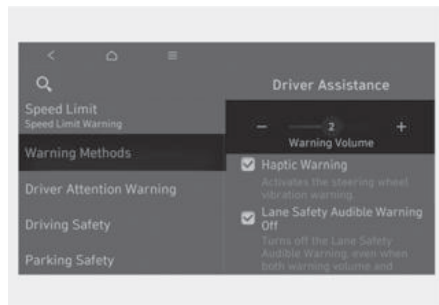

With the vehicle on, go to **Setup > Vehicle > Driver Assistance > Warning Methods** from the Settings in the infotainment system to select the following:

- **Warning Volume:** The Warning Volume can be adjusted.

If you turn off the **Warning Volume**, for your safety, the Hands-off warning volume may warn you with a low volume.

- **Driving Safety Priority:** Your vehicle lowers all other audio volumes when the Driver Assistance system warning sounds.

## **i** Information

- If you change the Warning Methods, Warning Methods of other Driver Assistance systems may change.
- If the vehicle is restarted, Warning Methods will maintain the last setting.
- There may be no Settings menu depending on the feature applied to your vehicle.

## Lane Following Assist Operation

### Turning Lane Following Assist On/Off

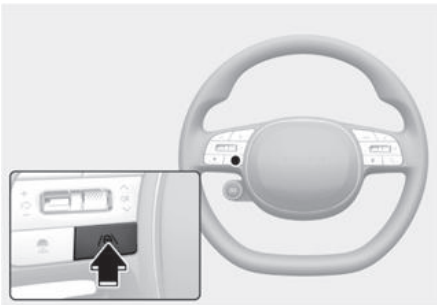

With the vehicle on, short press the Lane Driving Assist button located on the steering wheel to turn on Lane Following Assist. The grey or green (🚗➡️) indicator light will illuminate on the instrument cluster.

Press the button again to turn off the function.

## Lane Following Assist



If the vehicle ahead and/or both lane markings are detected and your vehicle speed is below 110 mph (180 km/h), the green (🚗➡️) indicator light illuminates on the instrument cluster, and Lane Following Assist helps center the vehicle in the lane by assisting the steering wheel.

### **⚠️ CAUTION**

When the steering wheel is not assisted, the white (🚗➡️) indicator light blinks and changes to grey.



## Hands-off warning



If the driver takes their hands off the steering wheel for several seconds, the **'Keep hands on steering wheel'** warning message will appear and an audible warning will sound in stages.

First stage: Warning message

Second stage: Warning message (red steering wheel) and audible warning

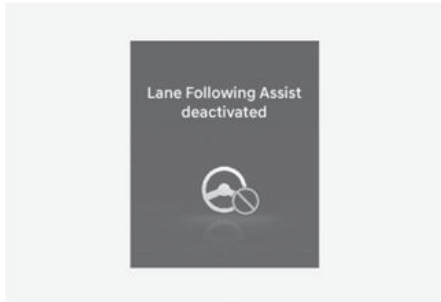

If the driver still does not have their hands on the steering wheel after the hands-off warning, the **'Lane Following Assist deactivated'** warning message will appear and Lane Following Assist will be automatically canceled.

## ⚠ WARNING

- The steering wheel may not be assisted if the steering wheel is held very tight or the steering wheel is steered over a certain degree.
- Lane Following Assist does not operate at all times. It is the responsibility of the driver to safely steer the vehicle and to maintain the vehicle in its lane.
- The hands-off warning message may appear late depending on road conditions. Always have your hands on the steering wheel while driving.
- If the steering wheel is held very lightly the hands-off warning message may appear because Lane Following Assist may not recognize that the driver has their hands on the steering wheel.
- If you attach objects to the steering wheel, the hands-off warning may not work properly.

## *i* Information

- For more information on instrument cluster settings, refer to the "Cluster Display Control" section in chapter 4.
- When both lane markings are detected, the lane lines on the instrument cluster will change from grey to white.

Lane undetected



Lane detected



- The images and colors in the instrument cluster may differ depending on the instrument cluster type or theme selected from the settings menu.
- If lane markings are not detected, steering wheel control by Lane Following Assist can be limited depending on whether a vehicle is in front or the driving conditions of the vehicle.
- Even though the steering is assisted by Lane Following Assist, the driver may control the steering wheel.
- The steering wheel may feel heavier or lighter when the steering wheel is assisted by Lane Following Assist than when it is not.

## Lane Following Assist Malfunction and Limitations

### Lane Following Assist malfunction

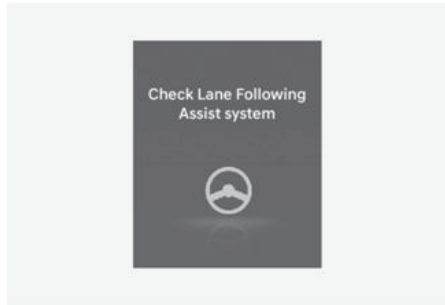

When Lane Following Assist is not working properly, the '**Check Lane Following Assist system**' warning message will appear on the instrument cluster for several seconds, and the master (⚠) warning light illuminates on the instrument cluster. If this occurs, have the vehicle inspected by an authorized HYUNDAI dealer.

### Limitations of Lane Following Assist

For more information on Lane Following Assist's limitations, refer to the "Lane Keeping Assist (LKA)" section in this chapter.

#### **i** Information

For more information on "Warnings" when using Lane Following Assist, refer to the "Lane Keeping Assist (LKA)" section in this chapter.

#### **⚠** WARNING

Loading freight exceeding the maximum load or placing freight unevenly may undermine driving safety. This may also prevent Lane Following Assist from operating properly.

## Highway Driving Assist (HDA)

### Basic function

Highway Driving Assist detect lanes and vehicles ahead, and help maintain the distance from the vehicle ahead and the set speed, and center your vehicle in the lane while driving on the highway.

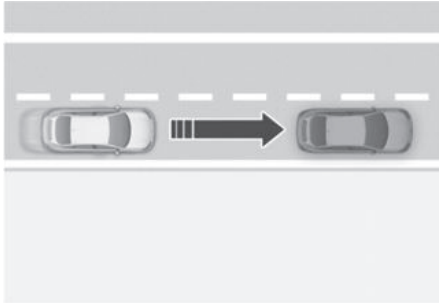

### Highway Lane Change Assist

**+** if equipped

Highway Lane Change Assist function helps change lanes to the direction you operate the turn signal switch if the function judges that lane change is possible.

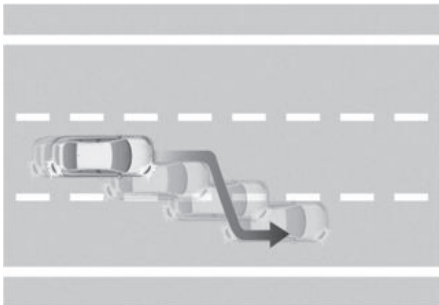

### *i* Information

- Highway Driving Assist is available only on controlled access road of certain highways.
  - Controlled access road indicates roads with limited entrances and exits that allow uninterrupted high speed traffic flow. Only passenger cars and motorcycles are allowed on controlled access roads.
- Additional highways may be expanded by future navigation updates.

#### Available Highway (Controlled access road)

USA	Select Interstate Highway and U.S. (Federal) and State Highways
Canada	Select Provincial and Territorial Highways

### *i* Information

Highway Driving Assist operates on main roads of highways, and does not operate on interchanges or junctions.

### *Detecting sensor*



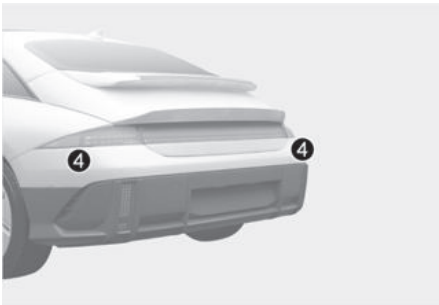
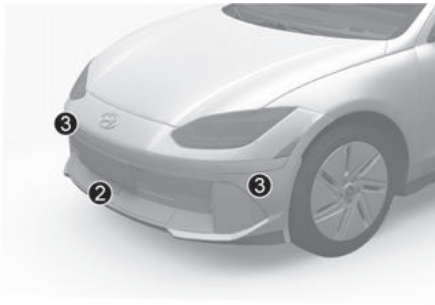

- (1) Front view camera,
- (2) Front radar,
- (3) Front corner radar (if equipped),
- (4) Rear corner radar (if equipped)

Refer to the picture above for the detailed location of the detecting sensors.

**CAUTION**

For more information on the precautions of the detecting sensors, refer to the "Forward Collision-Avoidance Assist (FCA)" section in this chapter.

## Highway Driving Assist Settings

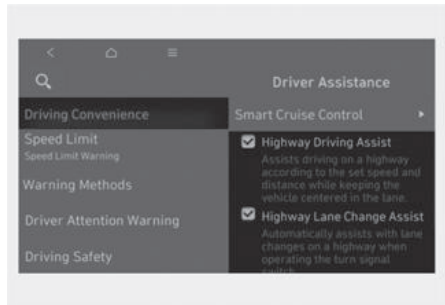

With the vehicle on, select or deselect **Setup > Vehicle > Driver Assistance > Driving Convenience** from the Settings menu to set whether to use each function.

### Basic function

If **Highway Driving Assist** is selected, it helps maintain distance from the vehicle ahead, maintain the set speed, and helps center the vehicle in the lane.

### Highway Lane Change Assist

**+ if equipped**

If **Highway Lane Change Assist** is selected, it helps the driver change lanes.

### i Information

- When **Highway Driving Assist** is deselected, the setting for Highway Lane Change Assist cannot be changed.
- If there is a problem with the functions, the settings cannot be changed. Have the vehicle inspected by an authorized HYUNDAI dealer.
- If the vehicle is restarted, the functions will maintain the last setting.

## WARNING

For your safety, only change the settings after parking the vehicle at a safe location.

### Warning Methods

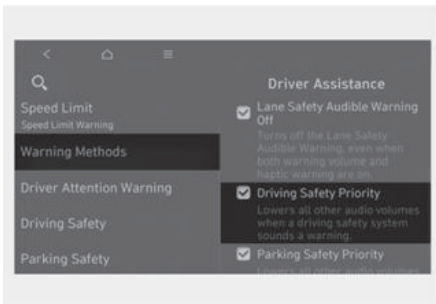
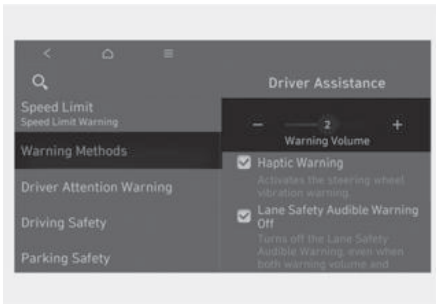

With the vehicle on, go to **Setup > Vehicle > Driver Assistance > Warning Methods** from the Settings in the infotainment system to select the following:

- **Warning Volume:** The Warning Volume can be adjusted.

If you turn off the **Warning Volume**, for your safety, the Hands-off warning volume may warn you with a low volume.

- **Driving Safety Priority:** Your vehicle lowers all other audio volumes when the Driver Assistance system warning sounds.

## *i* Information

- If you change the Warning Methods, Warning Methods of other Driver Assistance systems may change.
- If the vehicle is restarted, Warning Methods will maintain the last setting.
- There may be no Settings menu depending on the feature applied to your vehicle.

## Highway Driving Assist Operation

### Basic function

#### Displaying operating status

You can see the status of the Highway Driving Assist operation in the Driving Assist view on the instrument cluster. For more information, refer to the "View Modes" section in chapter 4.

Highway Driving Assist will be displayed as below depending on the status of the function.

Operating state



Standby state

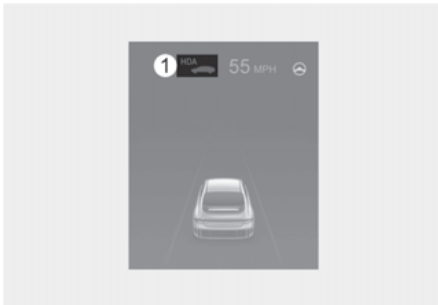

1. Highway Driving Assist indicator, whether there is a vehicle ahead and the selected distance level are displayed.
  - Highway Driving Assist indicator (HDA)
    - Green HDA: Operating state
    - Grey HDA: Standby state
    - White HDA blink: Accelerator depressed state
2. Set speed
3. Lane Following Assist indicator
4. Whether there is a vehicle ahead and the selected headway
5. Whether the lane is detected or not

### **i** Information

- For more information on the display refer to the "Smart Cruise Control (SCC)" and "Lane Following Assist (LFA)" sections in this chapter.
- The images and colors in the instrument cluster may differ depending on the instrument cluster type or theme selected from the settings menu.

### Highway Driving Assist operation

Highway Driving Assist operates when:

- Driving on the main road of highways, and turning on Highway Driving Assist by pressing the Driving Assist button
- Entering the main road of highways while Lane Following assist and Smart Cruise Control are operating

### Restarting after stopping



When Highway Driving Assist is operating, your vehicle will stop if the vehicle ahead of you stops. Also, if the vehicle ahead of you starts moving within 30 seconds after the stop, your vehicle will start as well. In addition, after the vehicle has stopped and 30 seconds have passed, the **'Use switch or pedal to accelerate'** message will appear on the instrument cluster. Depress the accelerator pedal or operate the + switch, - switch or  switch to start driving.

## Hands-off warning

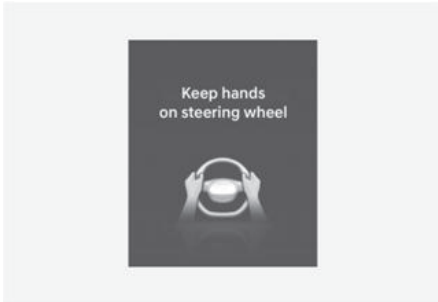

If the driver takes their hands off the steering wheel for several seconds, the **'Keep hands on steering wheel'** warning message will appear and an audible warning will sound in stages.

First stage: Warning message

Second stage: Warning message (red steering wheel) and audible warning

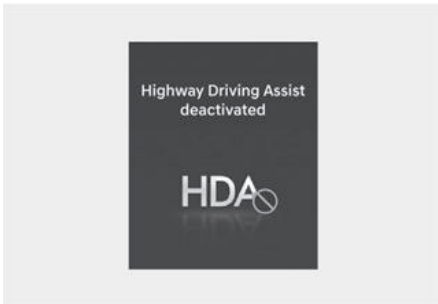

If the driver still does not have their hands on the steering wheel after the hands-off warning, **'Highway Driving Assist deactivated'** warning message will appear and Highway Driving Assist and Lane Change Assist will be automatically canceled.

## Driving speed limit



When Highway Driving Assist is canceled by the hands-off warning, The driving speed will be limited.

While Driving Speed Limit function is operating, the **'Driver's grasp not detected. Driving speed will be limited'** warning message will appear on the instrument cluster, and an audible warning will sound continuously.

## Driving to one side within lane

**+** if equipped

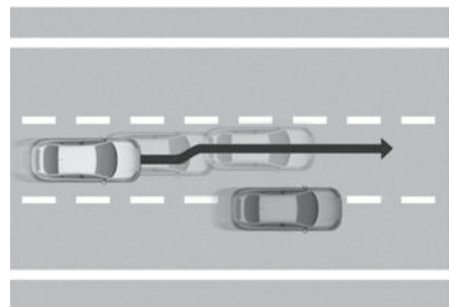

When vehicle speed is above 40 mph (60 km/h), if a vehicle around you is driving at a close distance, your vehicle will control steering in the opposite direction of the vehicle to assist in safe driving.

If there are detected vehicles on both sides of the lane that are driving close to you, your vehicle does not control steering in either direction.

### Highway Driving Assist standby

When the Smart Cruise Control is temporarily canceled while Highway Driving Assist is operating, Highway Driving Assist will be in the standby state. At this time, Lane Following Assist will operate properly.

### **i** Information

- Driving Speed Limit helps you drive below 40 mph (60 km/h). At this time, the vehicle decelerates due to the vehicle ahead. After the vehicle has decelerated, it cannot automatically accelerate.
- Driving Speed Limit will cancel in the following circumstances:
  - When the driver grabs the steering wheel again
  - When the driver turns on Lane Following Assist by pressing the Lane Driving Assist button
  - When +, -, || switch or button is operated, or the accelerator pedal or the brake pedal is depressed

### Highway Lane Change Assist

**+** If equipped

#### Displaying operating status

You can see the status of the Highway Lane Change Assist function operation in the Driving Assist view on the instrument cluster. For more information, refer to the "View Modes" section in chapter 4.

Highway Lane Change Assist function will be displayed as below depending on the status of the function.





Ready/Operating



Standby/Canceled



#### 1. Highway Lane Change Assist indicator

- Green  on : Ready state
- Green  blink : Operating state
- Grey  on : Standby state
- White  blink : Canceled state (display only a certain time)



## 2. Lane line

The lane line is displayed same as the Highway Lane Change Assist indicator (1). However, if the function is on standby, it displays whether the lane line is detected.

## 3. Green arrow and shade

The green arrow is displayed when a certain amount of time has passed after the function has started operating, and until the lane change has completed.

## 4. Message

- Message is displayed when the function does not operate even though the turn signal is used.
- Message is displayed when the function is canceled while operating.

### To turn on Highway Lane Change Assist

Highway Lane Change Assist function will turn on when the following conditions are satisfied.

- The Driving Assist button or Lane Driving Assist button is used to turn on Highway Driving Assist.

### Highway Lane Change Assist ready to operate

While Highway Lane Change Assist function is on, the function will be ready to operate when all the following conditions are satisfied:

- Highway Driving Assist is operating
- Lane Following Assist is operating
- A vehicle in the rear area of your vehicle is detected more than once after the vehicle is turned on
- Your vehicle speed is above 40 mph (60 km/h)
- Hands-off warning is not displayed on the instrument cluster
- Hazard warning flasher is off

## Information

- While Lane Change Assist function is turned on (indicator on), Lane Following Assist will not cancel even if the turn signal indicator or hazard warning flasher is operating.
- Lane Change Assist function turns off automatically when driven in the following road conditions:
  - One driving lane
  - A road with no structure, such as a medium strip, guardrails, etc.
  - There is a pedestrian or cyclist on the road ahead
- When the function is in the ready state, and vehicle speed is below 35 mph (55 km/h), the function will change to the standby state.

## WARNING

When Highway Lane Change Assist function turns off while operating, steering assist will be temporarily canceled. Always be cautious while driving.

### Highway Lane Change Assist operation

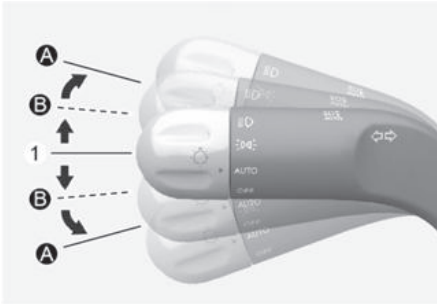

#### (1) Center

Highway Lane Change Assist function will operate, when you push the turn signal lever up or down to the A or B position while the function is in the ready state (the indicator is green), and all of the following conditions are satisfied:

- The driver has his/her hand on the steering wheel
- There is no collision risk in the direction of lane change
- There is a single dotted lane line in the direction of lane change
- There are no Forward Collision-Avoidance Assist and Blind Spot Collision-Avoidance Assist warnings
- The vehicle is driven in the middle of the lane (should not be driving close to one side of the lane)
- The road you are driving on, or the road you are about to change lane is a road that the function can operate

### *i* Information

- Highway Lane Change Assist operates when the turn signal lever is positioned at A. If the turn signal lever is released to the center (1) before stepping on the lane, Highway Lane Change Assist cancels. If the turn signal lever is released to the center (1) after stepping on the lane, Highway Lane Change Assist changes the lane and turns off the turn signal after lane change is complete.
- When the turn signal lever is placed at B position for a certain period of time, the green arrow will appear. At this time, even when the lever is released and returns to its original position (1), lane change will still be assisted.
- While lane change is being made by the function, the turn signal indicator will blink even when the turn signal lever is not held, and the turn signal indicator will turn off when lane change is complete.

#### Highway Lane Change Assist standby

Highway Lane Change Assist function will be in the standby state when one of the ready state condition is not satisfied, or when entering or driving on one of the following roads:

- Road within a certain distance from the tollbooth on the main road of the highway
- The road ahead ends without an interchange or junction
- Road with sharp curves
- Road with narrow lanes

### Highway Lane Change Assist cancel

The function will be canceled when:

- The turn signal lever is moved to the "A" position while the Highway Lane Change Assist function is operating and placed in the center (1) before stepping on the lane line
- The turn signal lever is turned on in the opposite direction of lane change
- The steering wheel is steered sharply

### WARNING

- While Highway Driving Assist is operating, the function will cancel if one of the following occurs:
    - Highway Driving Assist is turned off
    - Lane Following Assist or Smart Cruise Control is turned off or temporarily canceled
    - Hands-off warning message is displayed on the instrument cluster
    - The hazard warning flasher is turned on
    - Forward Collision-Avoidance Assist or Blind-Spot Collision-Avoidance Assist warning message is displayed
    - Possible collision is detected in the next lane, even though there are no Forward Collision-Avoidance Assist and Blind-Spot Collision-Avoidance Assist warning
    - The target lane to make a lane change disappears
    - The target lane to make a lane change is not detected
    - There is a problem with turn signal lights
  - Highway Lane Change Assist function is off (The function turns off when the function is turned off from the settings menu, when the road changes to a one-way road, when there is a intersection or crosswalk ahead, when you enter a road with no structure, such as a medium strip, guardrail, etc., or when there is a pedestrian or cyclist on the driving lane.)
  - Your vehicle speed is below 35 mph (55 km/h)
  - While the function is operating, when the function is canceled, depending on the driving conditions, the vehicle may drive to the middle of the driving lane or steering assist may stop. Always pay attention to road and driving conditions while driving.
  - The function may not operate properly on roads with pedestrians or cyclists, such as an intersection or crosswalk. Always pay attention to road and driving conditions while driving.
-

## Highway Driving Assist Malfunction and Limitations

### Highway Driving Assist malfunction

Type A/Type B

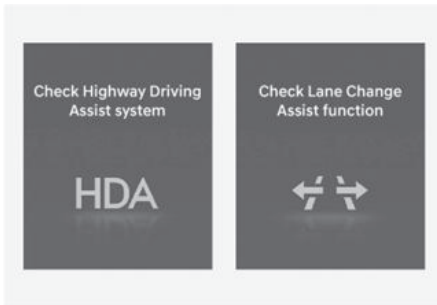

When Highway Driving Assist or Highway Lane Change function is not working properly, the '**Check Highway Driving Assist system**' or '**Check Lane Change Assist function**' warning message will appear, and the  warning light will illuminate on the instrument cluster. Have the vehicle inspected by an authorized HYUNDAI dealer.

#### WARNING

- The driver is responsible for controlling the vehicle and safe driving.
- Always have your hands on the steering wheel while driving.
- Highway Driving Assist is a supplemental function that assists the driver in driving the vehicle and is not a complete autonomous driving system. Always check road conditions, and if necessary, take appropriate actions to drive safely.
- Always have your eyes on the road, and it is the responsibility of the driver to avoid violating traffic laws. The vehicle manufacturer is not responsible for any traffic violation or accidents caused by the driver.

- Highway Driving Assist may not be able to recognize all traffic situations. Highway Driving Assist may not detect possible collisions due to limitations of the function. Always be aware of the limitations of the function. Obstacles such as vehicles, motorcycles, bicycles, pedestrians, or unspecified objects or structures such as guardrails, tollbooth, etc., that may collide with the vehicle may not be detected.
- Highway Driving Assist will turn off automatically under the following situations:
  - Driving on roads that Highway Driving Assist does not operate, such as a rest area, intersection, junction, etc.
  - The navigation does not operate properly such as when the navigation is being updated or restarted
- Highway Driving Assist may inadvertently operate or turn off depending on road conditions (navigation information) and surroundings.
- Lane Following Assist function may be temporarily disabled when the front view camera cannot detect lanes properly or the hands-off warning is on.
- You may not hear the warning sound of Highway Driving Assist if the surrounding is noisy.
- If the vehicle is driven at high speed above a certain speed at a curve, your vehicle may drive to one side or may depart from the driving lane.
- When you are towing a trailer or another vehicle, turn off Highway Driving Assist for safety reasons.
- The hands-off warning message may appear early or late depending on how the steering wheel is held or road conditions. Always have your hands on the steering wheel while driving.

- For your safety, please read the owner's manual before using the Highway Driving Assist.
- Highway Driving Assist will not operate when the vehicle is started, or when the detecting sensors or navigation is being initialized.

### **Limitation of Highway Driving Assist**

Highway Driving Assist and Highway Lane Change function may not operate properly, or may not operate under the following circumstances:

- The map information and the actual road is different because the navigation is not updated
- The map information and the actual road is different because of real-time GPS data or map information error
- The infotainment system is overloaded by simultaneously performing functions such as route search, video playback, voice recognition, etc.
- GPS signals are blocked in areas such as a tunnel
- The driver goes off course or the route to the destination is changed or canceled by resetting the navigation
- The vehicle enters a service station or rest area
- Android Auto or Car Play is operating
- The navigation cannot detect the current vehicle position (for example, elevated roads including overpass adjacent to general roads or nearby roads exist in a parallel way)
- White single dotted lane line or road edge cannot be detected
- The road is temporarily controlled due to construction, etc.
- There is no structure, such as a medium strip, guardrails, etc., on the road
- There is a changeable lane in the direction of lane change
- If a trailer, carrier, etc., is installed

### **i Information**

For more information on the limitations of the front view camera, front radar, front corner radar and rear corner radar, refer to the "Forward Collision-Avoidance Assist (FCA)" section in this chapter.

### **i Information**

This device complies with Part 15 of the FCC rules.

Operation is subject to the following three conditions:

1. This device may not cause harmful interference, and
2. This device must accept any interference received, including interference that may cause undesired operation.
3. Changes or modifications not expressly approved by the party responsible for compliance could void the user's authority to operate the device.

### **i Information**

Radio frequency radiation exposure information:

This equipment complies with FCC radiation exposure limits set forth for an uncontrolled environment.

This equipment should be installed and operated with minimum distance of 8 in. (20 cm) between the radiator (antenna) and your body.

This transmitter must not be co-located or operating in conjunction with any other antenna or transmitter.

## Rear View Monitor (RVM)

 If equipped

Rear View Monitor displays the area behind your vehicle to help with safe parking or driving.

### Detecting sensor

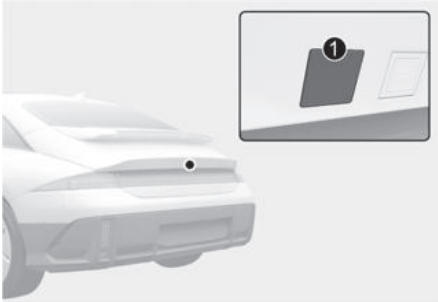

(1) Wide-rear view camera

Refer to the picture above for the detailed location of the detecting sensor.

## Rear View Monitor Settings

### Warning Methods

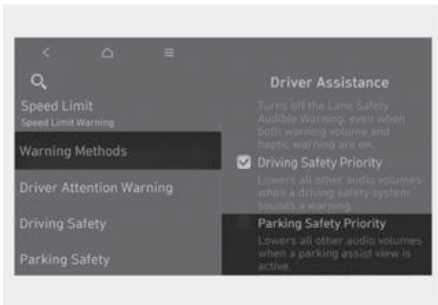

With the vehicle on, go to **Setup > Vehicle > Driver Assistance > Warning Methods** from the Settings in the infotainment system to select the following:

- **Parking Safety Priority:** Your vehicle lowers all other audio volumes when Rear View Monitor is operating.

### Information

- If you change the Warning Methods, Warning Methods of other Driver Assistance systems may change.
- If the vehicle is restarted, Warning Methods will maintain the last setting.
- There may be no Settings menu depending on the feature applied to your vehicle.

### Camera settings

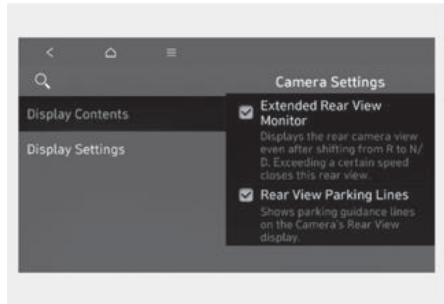

- You can change Rear View Monitor **Display Contents** by touching the setup icon  on the screen while Rear View Monitor is operating, or selecting **Setup > Vehicle > Driver Assistance > Parking Safety > Camera Settings** from the Settings menu while the vehicle is on.
- In the **Display Contents**, you can change settings for **Extended Rear View Monitor** and **Rear View Parking Lines**.

### Information

There may be no Setting menu depending on the feature applied to your vehicle.

### Extended Rear View Monitor

With the vehicle on, select **Camera Settings > Display Contents > Extended Rear View Monitor** from the Settings menu to turn on **Extended Rear View Monitor** function and deselect to turn off the function

### Rear View Parking Lines

If **Rear View Parking Lines** is selected, the rear view parking guide lines and rear top view guide lines will be displayed at the left side of the infotainment system.

#### *i* Information

- The horizontal guideline of the Rear View Parking Guidance shows the distance of 20 in (0.5 m), 40 in (1 m) and 91 in (2.3 m) from the vehicle.
- The horizontal guideline of the Rear Top View Parking Guidance shows the distance 20 in (0.5 m) and 60 in (1.5 m) from the vehicle.

## Rear View Monitor Operation

### Parking/View button



Press the Parking/View button (1) while the gear is in P (Park) to turn on Rear View Monitor.

Press the Parking/View button (1) while the gear is in D (Drive) or N (Neutral) to turn on Rear View Monitor while driving.

### Rear view



#### Operating conditions

- Shift the gear to R (Reverse), the rear view will appear on the screen.
- Press the Parking/View button (1) while the gear is in P (Park), the rear view will appear on the screen.
- Touch the **(P)**, the rear view will appear on the screen.

#### Off conditions

- The rear view cannot be turned off when the gear is in R (Reverse).
- Press the Parking/View button (1) again while the gear is in P (Park) with the rear view on the screen, the rear view will turn off.
- Shift the gear from R (Reverse) to P (Park), the rear view will turn off.

#### *i* Information

When the gear is in R (Reverse), the rear view does not turn off.

### Rear top view



When you touch the  icon, the top view is displayed on the screen and shows the distance from the vehicle in the back of your vehicle while parking.

### Extended Rear View Monitor

Extended Rear View Monitor function maintains showing the rear view when the gear is R (Reverse), N (Neutral) or D (Drive).

### Operating conditions

The gear is in P (Park), N (Neutral) or D (Drive), and vehicle speed is 6 mph (10 km/h) or less.

### Off conditions

- When vehicle speed is above 6 mph (10 km/h), the rear view will turn off.
- Shift the gear to P (Park), the rear view will turn off.
- Press the Parking/View button (1), the rear view will turn off.

## Rear View Monitor Malfunction and Limitations

### Rear View Monitor malfunction

When Rear View Monitor is not working properly, or the screen flickers, or the camera image does not display properly, have the vehicle inspected by an authorized HYUNDAI dealer.

### WARNING

- The rear view camera does not cover the complete area behind the vehicle. The driver should always check the rear area directly through the inside rearview mirror and outer side view mirror before parking or backing up.
- The image shown on the screen may differ from the actual distance of the object. Make sure to directly check the vehicle's surroundings for safety.
- Always keep the rear view camera lens clean. If the lens is covered with foreign material, it may adversely affect camera performance and Rear View Monitor may not operate properly. However, do not use chemical solvents such as strong detergents containing high alkaline or volatile organic solvents (gasoline, acetone, etc.). This may damage the camera lens.



## Surround View Monitor (SVM)

**+** if equipped

Surround View Monitor uses the wide view cameras and displays images around your vehicle through the infotainment system screen to help with safe parking or driving.

### Detecting sensor

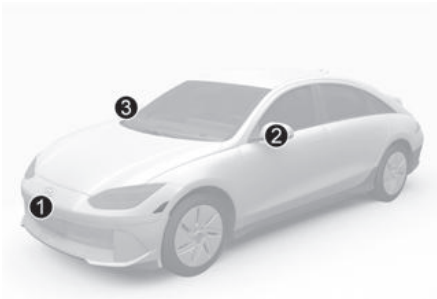

- (1) Wide-front view camera
- (2) Wide-side view camera (Below the side view mirror)
- (3) Wide-side view camera (Below the side view mirror)
- (4) Wide-rear view camera

Refer to the picture above for the detailed location of the detecting sensors.

## Surround View Monitor Settings

### Warning Methods

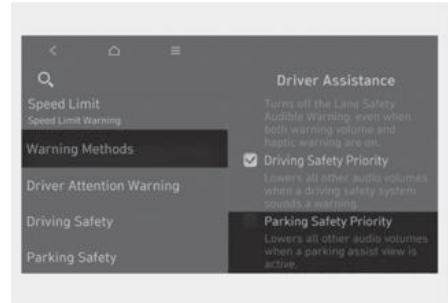

With the vehicle on, go to **Setup > Vehicle > Driver Assistance > Warning Methods** from the Settings in the infotainment system to select the following:

- **Parking Safety Priority:** Your vehicle lowers all other audio volumes when Surround View Monitor is operating.

### *i* Information

- If you change the Warning Methods, Warning Methods of other Driver Assistance systems may change.
- If the vehicle is restarted, Warning Methods will maintain the last setting.
- There may be no Settings menu depending on the feature applied to your vehicle.

## Camera settings

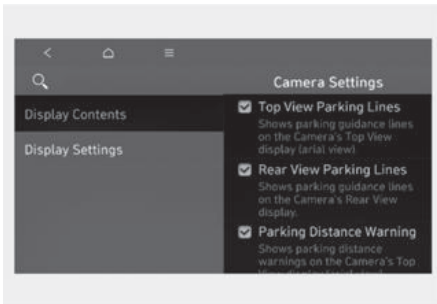

- You can change Surround View Monitor **Display Contents** or **Display Settings** by touching the setup icon (⚙️) on the screen while Surround View Monitor is operating, or selecting **Setup > Vehicle > Parking Safety > Camera Settings** from the Settings menu while the vehicle is on.
- In the **Display Contents**, you can change settings for **Top View Parking Lines**, **Rear View Parking Lines** and **Parking Distance Warning**.

### *i* Information

There may be no Setting menu depending on the feature applied to your vehicle.

### Parking Distance Warning

When the **Parking Distance Warning** is selected, parking distance warning is displayed on the right side of the Surround View Monitor screen.

### Top View Parking Guidance

When the **Top View Parking Lines** is selected, parking guidance is displayed on the right side of the Surround View Monitor screen.

### *i* Information

The horizontal guideline of the Rear Top View Parking Guidance shows the trunk opening distance and the distance of 1.6 ft. (0.5 m), 6.6 ft. (2 m) from the vehicle.

### Rear View Parking Guidance

When the **Rear View Parking Lines** is selected, parking guidance is displayed in the rear view.

### *i* Information

The horizontal guideline shows the distance of 20 in (0.5 m), 40 in (1 m) and 91 in (2.3 m) from the vehicle.

### Surround View Monitor Auto On

With the vehicle on, select **Driver Assistance > Parking Safety > Surround View Monitor Auto On** from the Settings menu to use the function.

### *i* Information

For more information on Surround View Monitor Auto On, refer to the "Surround View Monitor Operation" in this chapter.

## Surround View Monitor Operation

### Parking/View button



Press the Parking/View button (1) to turn on Surround View Monitor.

Press the button again to turn off the function.

### Front view



The front image is displayed on the screen when the gear is in N (Neutral) or D (Drive) to assist in parking. Using the view button (2) you may select top view, front view and side view.

### Operating conditions

- The gear is in N (Neutral) or D (Drive), and vehicle speed is 6 mph (10 km/h) or less.
- The Parking/View button (1) is pressed, while the gear is in N (Neutral) or D (Drive), and vehicle speed is 6 mph (10 km/h) or less.
- Surround View Monitor Auto On function will operate when the following conditions are satisfied:
  - With **Setup > Vehicle > Driver Assistance > Parking Safety > Surround View Monitor Auto On** selected from the Settings menu, the front view while parking is displayed.

### Off conditions

- The Parking/View button (1) or the Infotainment system button (3) is Pressed.
- Vehicle speed is above 6 mph (10 km/h).
- The gear is shifted to P (Park).

### *i* Information

Surround View Monitor will turn off when vehicle speed is above 6 mph (10 km/h). However, Surround View Monitor will not turn on again although vehicle speed drops below 6 mph (10 km/h).

### **Rear view**

The rear image is displayed on the screen when the gear is in R (Reverse) or P (Park) to assist in parking. Using the view button (2) you may select top view, rear view and side view.

#### **Operating conditions**

- The gear is shifted to R (Reverse).
- The Parking/View button (1) is pressed, while the gear is in P (Park).

#### **Off conditions**

- The gear is shifted from R (Reverse) to P (Park).
- The Parking/View button (1) is pressed, while the gear is in P (Park).

### ***i* Information**

When the gear is in R (Reverse), the rear view does not turn off even if the infotainment system button (3) is pressed.

---

### **3D view**

The 3D view shows the image around the vehicle from various angles.

You can change angles by tapping the screen. Press the 3D View button again to return to the initial angle.

3D view will turn on when the 3D view is selected among the view buttons (2) under the following conditions:

- The gear is in P (Park), N (Neutral) or D (Drive) when vehicle speed is below 6 mph (10 km/h).
- The Surround View Monitor is turned on when the gear is in R (Reverse).

When the gear is in P (Park), N (Neutral) or D (Drive), 3D view will turn off under the following conditions:

- The gear is shifted to P (Park).
- The Parking/View button (1) is pressed.
- The infotainment system button (3) is pressed.
- The Home button (2) is pressed.
- Vehicle speed is above 6 mph (10 km/h).

When the gear is in R (reverse), 3D view will turn off under the following conditions.

- The gear is shifted to P (Park).

### ***i* Information**

3D view does not display guidelines.

---

## Surround View Monitor Malfunction and Limitations

### **Surround View Monitor malfunction**

When Surround View Monitor is not working properly, or the screen flickers, or the camera image does not display properly, have the vehicle inspected by an authorized HYUNDAI dealer.

### **Limitations of Surround View Monitor**

- The screen may be displayed abnormally, and an icon will appear at the top left side of the screen under the following circumstances:
  - The trunk is opened
  - The driver or front passenger door is opened
  - The side view mirror is folded

### **WARNING**

- Always look around your vehicle to make sure there are no objects or obstacles before moving the vehicle. What you see on the screen may differ from the actual vehicle's location.
- The image shown on the screen may differ from the actual distance of the object. Make sure to directly check the vehicle's surroundings for safety.
- Surround View Monitor is designed to be used on a flat surface. Therefore, if used on roads with different heights such as curbs and speed bumps, the image in the screen may not look correct.

- Always keep the camera lens clean.

If the lens is covered with foreign material, it may adversely affect camera performance and Surround View Monitor may not operate properly. However, do not use chemical solvents such as strong detergents containing high alkaline or volatile organic solvents (gasoline, acetone, etc.). This may damage the camera lens.

### **Information**

Surround View Monitor uses the cameras installed on the vehicle to show images around the vehicle through the infotainment system. The image shown on the screen may look unnatural depending on the surroundings.

## Rear Cross-Traffic Collision-Avoidance Assist (RCCA)

Rear Cross-Traffic Collision-Avoidance Assist detects vehicles approaching from the rear left or right while your vehicle is reversing and warns you of a possible collision with a warning message and a warning sound. Also, Rear Cross-Traffic Collision-Avoidance Assist may assist with braking your vehicle to help avoid a collision.

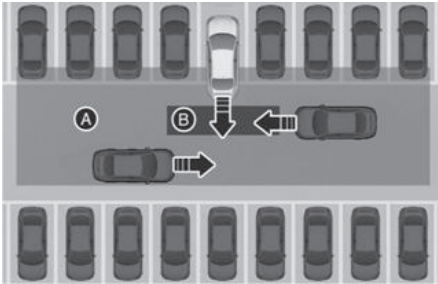

- [A] Rear Cross-Traffic Collision Warning operating range
- [B] Rear Cross-Traffic Collision-Avoidance Assist operating range

### CAUTION

Warning timing may vary depending on the speed of the approaching vehicle.

### Detecting sensor

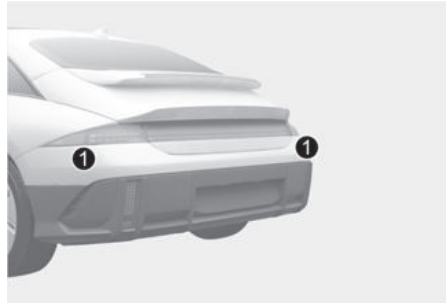

- (1) Rear corner radar

Refer to the picture above for the detailed location of the detecting sensors.

### Information

For more information on the precautions of the rear corner radar, refer to the “Blind-Spot Collision-Avoidance Assist (BCA)” section in this chapter.

## Rear Cross-Traffic Collision-Avoidance Assist Settings

### Rear Cross-Traffic Safety

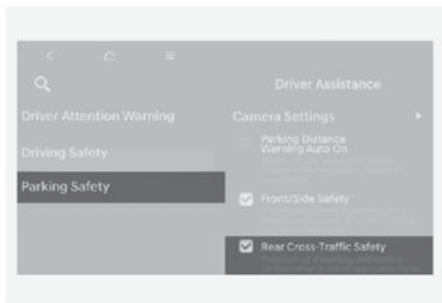

With the vehicle on, select **Setup > Vehicle > Parking Safety > Rear-Cross Traffic Safety** from the settings menu to turn on Rear Cross-Traffic Collision-Avoidance Assist and deselect to turn off the function.

#### **WARNING**

When the vehicle is restarted, Rear Cross-Traffic Collision-Avoidance Assist will always turn on. However, the driver should always be aware of the surroundings and drive safely especially if **Rear Cross-Traffic Safety** is deselected.

### Warning Methods

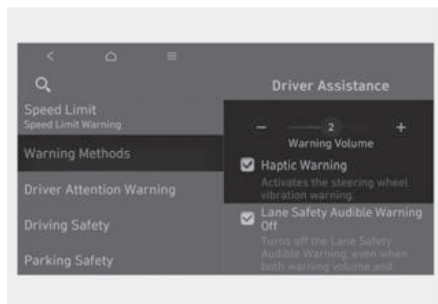

With the vehicle on, go to **Setup > Vehicle > Driver Assistance > Warning Methods** from the Settings in the infotainment system to select the following:

- **Warning Volume:** The Warning Volume can be adjusted.
- **Haptic Warning:** The steering wheel vibration can be set.

#### **Information**

- If you change the Warning Methods, Warning Methods of other Driver Assistance systems may change.
- If the vehicle is restarted, Warning Methods will maintain the last setting.
- There may be no Settings menu depending on the feature applied to your vehicle.
- The **Warning Volume** and **Haptic Warning** cannot be turned off at the same time. When one of the warnings is turned off, the other is activated.

### Rear Cross-Traffic Collision-Avoidance Assist Operation

Rear Cross-Traffic Collision-Avoidance Assist will warn and help control the vehicle depending on collision risk level: 'Collision Warning', 'Emergency Braking' and 'Stopping vehicle and ending brake control'.

### Collision Warning



- To warn the driver of an approaching vehicle from the rear left/right side of your vehicle, the warning light on the side view mirror will blink and a warning will appear on the instrument cluster. At the same time, an audible warning will sound. If Rear View Monitor is operating, a warning will also appear on the infotainment system.
- Rear Cross-Traffic Collision-Avoidance Assist will operate when all the following conditions are satisfied:
  - The gear is shifted to R (Reverse)
  - Vehicle speed is below 5 mph (8 km/h)
  - The approaching vehicle is within about 82 ft. (25 m) from the left and right side of your vehicle
  - The speed of the vehicle approaching from the left and right is above 3 mph (5 km/h)

### *i* Information

- If the operating conditions are satisfied, there will be a warning whenever the vehicle approaches from the left or right side even though your vehicle speed is 0 mph (0 km/h).
- The images and colors in the instrument cluster may differ depending on the instrument cluster type or theme selected from the instrument cluster.

### Emergency Braking



- To warn the driver of an approaching vehicle from the rear left/right side of your vehicle, the warning light on the side view mirror will blink and a warning message will appear on the instrument cluster. At the same time, an audible warning will sound. A warning will also appear on the infotainment system.



- Rear Cross-Traffic Collision-Avoidance Assist will operate when all the following conditions are satisfied:
  - The gear is shifted to R (Reverse)
  - Vehicle speed is below 5 mph (8 km/h)
  - The approaching vehicle is within about 5 ft. (1.5 m) from the left and right side of your vehicle
  - The speed of the vehicle approaching from the left and right is above 3 mph (5 km/h)
  - Emergency braking will be assisted to help prevent collision with approaching vehicles from the left and right.

### WARNING

Brake control will end when:

- The approaching vehicle is out of the detecting range
- The approaching vehicle passes behind your vehicle
- The approaching vehicle does not drive toward your vehicle
- The approaching vehicle speed slows down
- The driver depresses the brake pedal with sufficient power

### Stopping vehicle and ending brake control



- When the vehicle is stopped due to emergency braking, the '**Drive carefully**' warning message will appear on the instrument cluster.
- For your safety, the driver should depress the brake pedal immediately and check the surroundings.
- Brake control will end after the vehicle is stopped by emergency braking for about 2 seconds.
- During emergency braking, braking control by Rear Cross-Traffic Collision-Avoidance Assist will automatically cancel when the driver excessively depresses the brake pedal.

### WARNING

Take the following precautions when using Rear Cross-Traffic Collision-Avoidance Assist:

- For your safety, only change the Settings after parking the vehicle at a safe location.
- If any other system's warning message is displayed or audible warning is generated, Rear Cross-Traffic Collision-Avoidance Assist warning message may not be displayed and audible warning may not be generated.
- You may not hear the warning sound of Rear Cross-Traffic Collision-Avoidance Assist if the surrounding is noisy.

- Rear Cross-Traffic Collision-Avoidance Assist may not operate if the driver applies the brake pedal to avoid collision.
  - During Rear Cross-Traffic Collision-Avoidance Assist operation, the vehicle may stop suddenly injuring passengers and shifting loose objects. Always have the seat belt on and keep loose objects secured.
  - Even if there is a problem with Rear Cross-Traffic Collision-Avoidance Assist, the vehicle's basic braking will function normally.
  - When Rear Cross-Traffic Collision-Avoidance Assist is operating, braking control by the function will automatically cancel when the driver excessively depresses the accelerator pedal.
  - Rear Cross-Traffic Collision-Avoidance Assist does not operate in all situations and cannot avoid all collisions.
  - Rear Cross-Traffic Collision-Avoidance Assist may warn the driver late or may not warn the driver depending on the road and driving conditions.
  - The driver has the responsibility to control the vehicle. Do not solely depend on Rear Cross-Traffic Collision-Avoidance Assist. Rather, maintain a safe braking distance, and if necessary, depress the brake pedal to reduce driving speed or to stop the vehicle.
  - Never deliberately operate Rear Cross-Traffic Collision-Avoidance Assist on people, animal, objects, etc. It may cause serious injury or death.
- 

### CAUTION

The brake control may not operate properly depending on the status of ESC (Electronic Stability Control).

There will only be a warning when:

- The ESC (Electronic Stability Control) warning light is on
  - ESC (Electronic Stability Control) is engaged in a different function
- 

### Information

If braking is assisted by Rear Cross-Traffic Collision-Avoidance Assist, the driver must immediately depress the brake pedal and check vehicle surroundings.

- Brake control will end when the driver depresses the brake pedal with sufficient power.
  - After shifting the gear to R (Reverse), braking control will operate once for left and right vehicle approach.
-

## Rear Cross-Traffic Collision-Avoidance Assist Malfunction and Limitations

### **Rear Cross-Traffic Collision-Avoidance Assist malfunction**

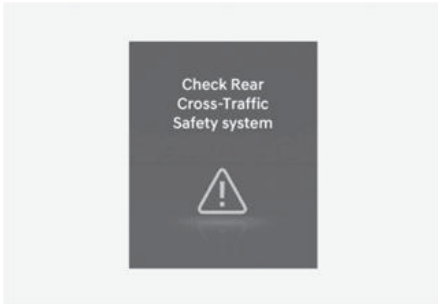

When Rear Cross-Traffic Collision-Avoidance Assist is not working properly, the '**Check Rear Cross-Traffic Safety system**' warning message will appear on the instrument cluster for several seconds, and the master (⚠) warning light will illuminate on the instrument cluster. If this occur, have vehicle inspected by an authorized HYUNDAI dealer.

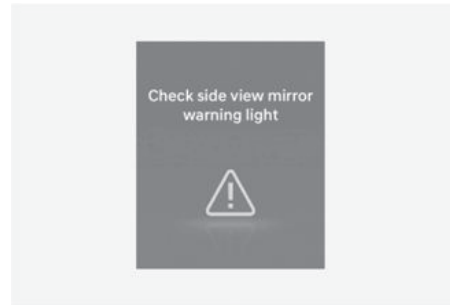

When the side view mirror warning light is not working properly, the '**Check side view mirror warning light**' warning message will appear on the instrument cluster for several seconds, and the master (⚠) warning light will illuminate on the instrument cluster. If this occur, have the vehicle inspected by an authorized HYUNDAI dealer.

### **Rear Cross-Traffic Collision-Avoidance Assist disabled**

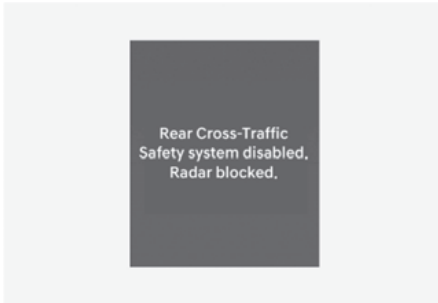

When the rear bumper around the rear-side radar or sensor is covered with foreign material, such as snow or rain, or installing a trailer or carrier, it can reduce the detecting performance and temporarily limit or disable Rear Cross-Traffic Collision-Avoidance Assist.

If this occurs, the **'Rear Cross-Traffic Safety system disabled. Radar blocked'** warning message will appear on the instrument cluster.

Rear Cross-Traffic Collision-Avoidance Assist will operate properly when such foreign material or trailer, etc., is removed.

If Rear Cross-Traffic Collision-Avoidance Assist does not operate properly after it is removed, have the vehicle inspected by an authorized HYUNDAI dealer.

#### **! WARNING**

- Even though the warning message does not appear on the instrument cluster, Rear Cross-Traffic Collision-Avoidance Assist may not operate properly.
- Rear Cross-Traffic Collision-Avoidance Assist may not operate properly in an area (for example, open terrain), where any objects are not detected after turning ON the vehicle.

#### **! CAUTION**

Turn off Rear Cross-Traffic Collision-Avoidance Assist to install or remove a trailer, carrier, or another attachment. Turn on Rear Cross-Traffic Collision-Avoidance Assist when finished.

### **Limitations of Rear Cross-Traffic Collision-Avoidance Assist**

Rear Cross-Traffic Collision-Avoidance Assist may not operate properly, or it may operate unexpectedly under the following circumstances:

- Departing from where trees or grass are overgrown
- Departing from where roads are wet
- Speed of the approaching vehicle is fast or slow

Braking control may not work, driver's attention is required in the following circumstances:

- The vehicle severely vibrates while driving over a bumpy road, uneven road or concrete patch
- Driving on a slippery surface due to snow, water puddle, ice, etc.
- The tire pressure is low or a tire is damaged
- The braking system has been modified
- Remote Smart Parking Assist is operating (if equipped)

#### **i Information**

For more information on the limitations of the rear corner radar, refer to the "Blind-Spot Collision-Avoidance Assist (BCA)" section in this chapter.

## WARNING

- Driving near a vehicle or structure

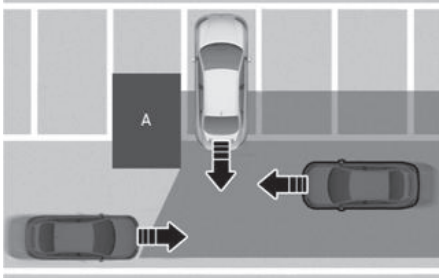

[A] Structure

Rear Cross-Traffic Collision-Avoidance Assist may be limited when driving near a vehicle or structure, and may not detect the vehicle approaching from the left or right. If this occurs, the function may not warn the driver or control the brakes when necessary.

Always check your surroundings while backing up.

- When the vehicle is in a complex parking environment

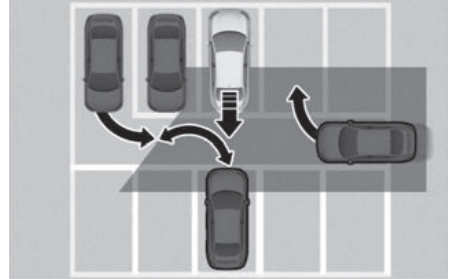

Rear Cross-Traffic Collision-Avoidance Assist may detect vehicles which are parking or pulling out near your vehicle (for example, a vehicle leaving beside your vehicle, a vehicle parking or pulling out in the rear area, a vehicle approaching your vehicle making a turn, etc.). If this occurs, the function may unnecessarily warn the driver and control the brake.

Always check your surroundings while backing up.

- When the vehicle is parked diagonally

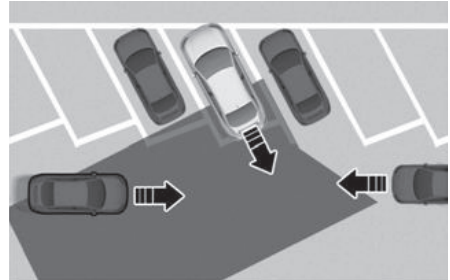

Rear Cross-Traffic Collision-Avoidance Assist may be limited when backing up diagonally, and may not detect the vehicle approaching from the left or right. If this occurs, the function may not warn the driver or control the brakes when necessary.

Always check your surroundings while backing up.

- When the vehicle is on or near a slope

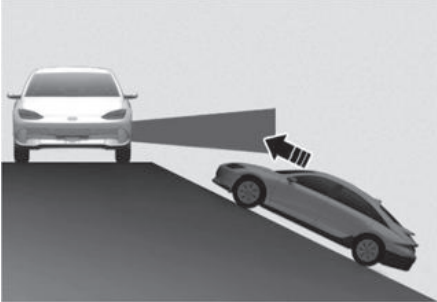

Rear Cross-Traffic Collision-Avoidance Assist may be limited when the vehicle is on an uphill or downhill slope, or near it, and may not detect the vehicle approaching from the left or right. If this occurs, the function may not warn the driver and control the brakes when necessary.

Always check your surroundings while backing up.

- Pulling into the parking space where there is a structure

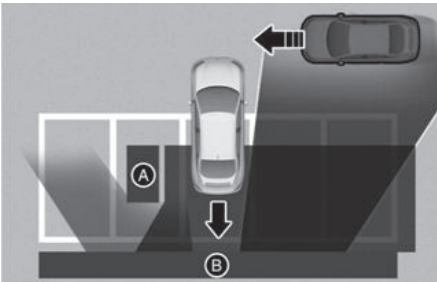

[A] Structure

[B] Wall

Rear Cross-Traffic Collision-Avoidance Assist may detect vehicles passing by in front of you when parking in reverse into a parking space with a wall or structure in the rear or side area. If this occurs, the function may unnecessarily warn the driver and control the brake.

Always check your surroundings while backing up.

- When the vehicle is parked rearward

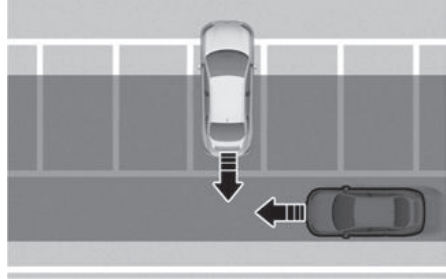

Rear Cross-Traffic Collision-Avoidance Assist may detect vehicles passing by behind you when parking in reverse into a parking space. If this occurs, the function may unnecessarily warn the driver and control the brake.

Always check your surroundings while backing up.

### WARNING

- When you are towing a trailer or another vehicle, turn off Rear Cross-Traffic Collision-Avoidance Assist for safety reasons.
- Rear Cross-Traffic Collision-Avoidance Assist may not operate properly if interfered by strong electromagnetic waves.
- Rear Cross-Traffic Collision-Avoidance Assist may not operate for 3 seconds after the vehicle is started, or the rear corner radars are initialized.

## Forward/Reverse Parking Distance Warning (PDW)

**+** if equipped

Forward/Reverse Parking Distance Warning can help warn the driver if an obstacle is detected within a certain distance when the vehicle is moving forward or in reverse at low speeds.

### Detecting sensor

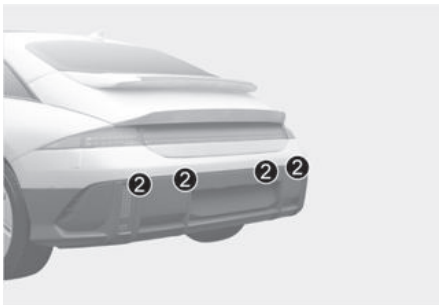
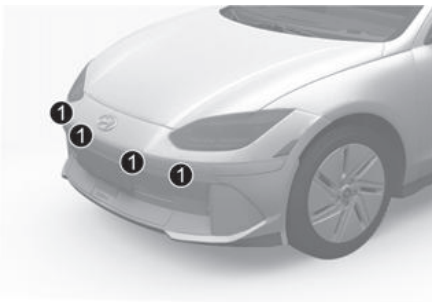

- (1) Front ultrasonic sensors,  
(2) Rear ultrasonic sensors

Refer to the picture above for the detailed location of the detecting sensors.

## Forward/Reverse Parking Distance Warning Settings

### Warning Methods

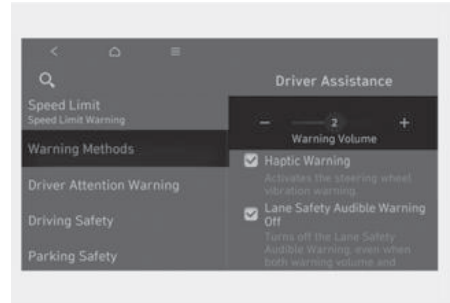

With the vehicle on, go to **Setup > Vehicle > Driver Assistance > Warning Methods** from the Settings in the infotainment system to select the following:

- **Warning Volume:** The Warning Volume can be adjusted.

If you turn off the **Warning Volume**, for your safety, the function may warn you with a low volume.

### **i** Information

- If you change the Warning Methods, Warning Methods of other Driver Assistance systems may change.
- If the vehicle is restarted, Warning Methods will maintain the last setting.
- There may be no Settings menu depending on the feature applied to your vehicle.

### **Parking Distance Warning Auto On**

To use Parking Distance Warning Auto On function, select **Setup > Vehicle > Driver Assistance > Parking Safety > Parking Distance Warning Auto On** from the infotainment system settings menu.

**i Information**

When **Parking Distance Warning Auto On** is selected, the Parking Safety button indicator (PWA) stays on.

**Forward/Reverse Parking Distance Warning Operation**

**Parking Safety button**



Press the Parking Safety (PWA) button to turn on Forward/Reverse Parking Distance Warning. Press the button again to turn off the function.

- When the gear is shift to R (Reverse), Parking Distance Warning will automatically turn on (Parking Safety button indicator on).

**Forward Parking Distance Warning**

Forward Parking Distance Warning will operate when one of the conditions is satisfied.

- The gear is shifted from R (Reverse) to D (Drive) with Reverse Parking Distance Warning on
- The gear is in D (Drive) and the Parking Safety button indicator light is on

- Shift to D (Drive) when the function is off (Only when **Setup > Vehicle > Driver Assistance > Parking Safety > Parking Distance Warning Auto On** is selected from the infotainment system settings menu.)
- The gear is shifted to R (only front corner warning is on)

**i Information**

- Forward Parking Distance Warning will operate only when the vehicle's forward speed is below 6 mph (10 km/h).
- Forward Parking Distance Warning is deactivated if the vehicle speed reaches above 18 mph (30 km/h). It will not reactivate although the vehicle speed drops below 6 mph (10 km/h).
- Only the front outer ultrasonic sensor will operate when the gear is in R (Reverse).

(Only when **Setup > Vehicle > Driver Assistance > Parking Safety > Parking Distance Warning Auto On** is not selected from the infotainment system settings menu.)

Distance from Object	Warning Indicator	Warning Sound
24-40 in. (60-100 cm)		Buzzer beeps intermittently
24-40 in. (30-60 cm)		Beeps more frequently
within 12 in. (30 cm)		Beeps continuously



- The corresponding indicator will illuminate whenever each ultrasonic sensor detects a person, animal or object in its sensing range. Also an audible warning will sound.
  - When more than two objects are detected at the same time, the closest one will be warned with an audible warning.
  - The shape of the indicator in the illustration may differ from the actual vehicle.
- The corresponding indicator will illuminate whenever each ultrasonic sensor detects a person, animal or object in its sensing range. Also an audible warning will sound.
  - When more than two objects are detected at the same time, the closest one will be warned with an audible warning.
  - The shape of the indicator in the illustration may differ from the actual vehicle.



### **Reverse Parking Distance Warning**

Reverse Parking Distance Warning will operate under the following conditions.

- The gear is shifted to R (Reverse).

#### **i Information**

Reverse Parking Distance Warning will operate when the vehicle's reverse speed is below 6 mph (10 km/h).

Distance from Object	Warning Indicator	Warning Sound
24-48 in. (60-120 cm)		Buzzer beeps intermittently
12-24 in. (30-60 cm)		Beeps more frequently
within 12 in. (30 cm)		Beeps continuously

## Forward/Reverse Parking Distance Warning Malfunction and Limitations

### **Parking Distance Warning malfunction**

After starting the vehicle, a beep will sound when the gear is shifted to R (Reverse) to indicate Parking Distance Warning is operating properly.

However, if one or more of the following occurs, first check whether the ultrasonic sensor is damaged or blocked with foreign material. If it still does not work properly, have the vehicle inspected by an authorized HYUNDAI dealer.

- The audible warning does not sound.
- The buzzer sounds intermittently.
- The '**Check Parking Distance Warning system**' warning message appears on the instrument cluster.

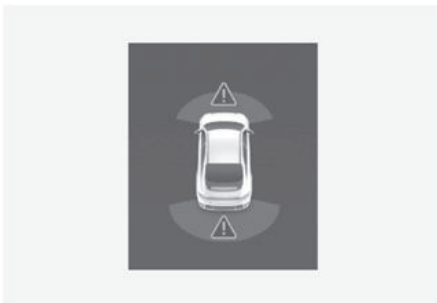
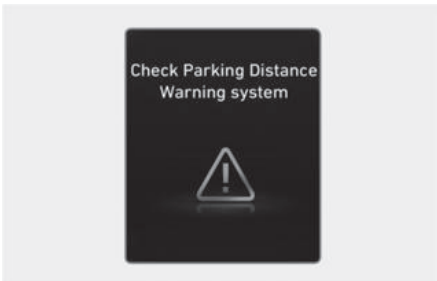

### **Parking Distance Warning disabled**

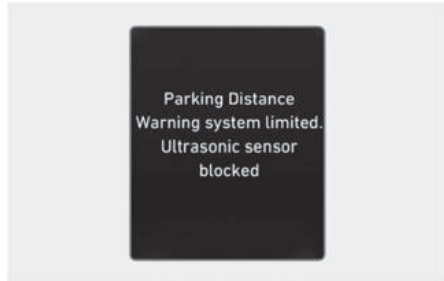

If this occurs the '**Parking Distance Warning system limited. Ultrasonic sensor blocked**' warning message appears on the instrument cluster. Parking Distance Warning will operate properly when snow, rain or foreign material is removed.

If Parking Distance Warning does not operate properly after obstruction (snow, rain, or foreign material) is removed (including trailer, carrier, etc., from the rear bumper), have the vehicle inspected by an authorized HYUNDAI dealer.

### **Limitations of Forward/Reverse Parking Distance Warning**

- Parking Distance Warning may not operate properly when:
  - Moisture is frozen to the sensor
  - Sensor is covered with substance, such as snow or water (Forward/Reverse Parking Distance Warning will operate properly when such substance is removed.)
  - The weather is extremely hot or cold
  - The sensor or sensor assembly is disassembled
  - The surface of the sensor is pressed hard or hit with a hard object
  - The surface of the sensor is scratched with a sharp object
  - The sensors or its surrounding area is directly sprayed with high pressure washer

- Parking Distance Warning may malfunction when:
  - Heavy rain or water spray is present
  - Water flows on the surface of the sensor
  - Affected by another vehicle's sensors
  - The sensor is covered with snow or ice
  - Driving on uneven road, gravel roads or bushes
  - Objects that generate ultrasonic waves are near the sensor
  - License plate is installed in a different spot from the original location
  - The vehicle bumper height or ultrasonic sensor installation has been modified
  - Attaching equipment or accessories next to the ultrasonic sensors
- The following objects may not be detected:
  - Sharp or slim objects, such as ropes, chains or small poles.
  - Narrow objects, such as corners of a square column
  - Objects, which tend to absorb sensor frequency, such as clothes, spongy material or snow.
  - Objects smaller than 100 cm (40 in.) in length and narrower than 6 in. (14 cm) in diameter.
  - Pedestrians, animals or objects that are very close to the ultrasonic sensors

### WARNING

- Parking Distance Warning is a supplemental function. The operation of Parking Distance Warning can be affected by several factors (including environmental conditions). It is the responsibility of the driver to always check the front and rear views before and while parking.
- Your new vehicle warranty does not cover any accidents or damage to the vehicle due to the malfunction of Parking Distance Warning.
- Pay close attention when driving near objects, pedestrians, and especially children. Some objects may not be detected by the ultrasonic sensors, due to the objects distance, size or material, all of which can limit the effectiveness of the sensor.
- Parking Distance Warning does not warn you in the order of detection. It varies depending on the speed of the vehicle or the shape of a person, animal, or object.
- If the Parking Distance Warning does not operate properly, you have the vehicle inspected by an authorized HYUNDAI dealer.

## Forward/Side/Reverse Parking Distance Warning (PDW)

 if equipped

Forward/Side/Reverse Parking Distance Warning uses the front, side, and rear ultrasonic sensors to detect and warns you if a person, animal, or object is within a certain distance when your vehicle is stopped or driving at low speed.

### Detecting sensor

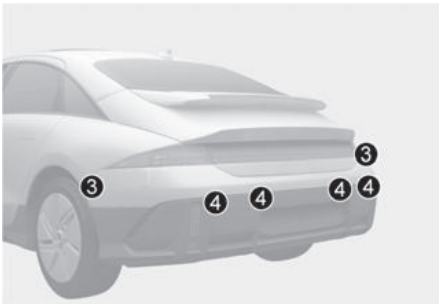
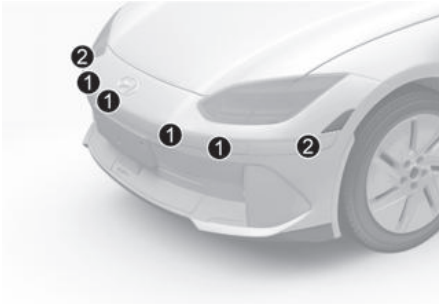

- (1) Front ultrasonic sensors
- (2) Front side ultrasonic sensors
- (3) Rear side ultrasonic sensors
- (4) Rear ultrasonic sensors

Refer to the picture above for the detailed location of the detecting sensors.

## Parking Distance Warning Settings

### Warning Methods

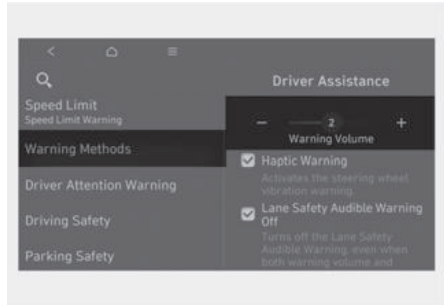

With the vehicle on, go to **Setup > Vehicle > Driver Assistance > Warning Methods** from the Settings in the infotainment system to select the following:

- **Warning Volume:** The Warning Volume can be adjusted.

If you turn off the **Warning Volume**, for your safety, the function may warn you with a low volume.

### Information

- If you change the Warning Methods, Warning Methods of other Driver Assistance systems may change.
- If the vehicle is restarted, Warning Methods will maintain the last setting.
- There may be no Settings menu depending on the feature applied to your vehicle.

### **Parking Distance Warning Auto On**

To use Parking Distance Warning Auto On function, select **Setup > Vehicle > Driver Assistance > Parking Safety > Parking Distance Warning Auto On** from the infotainment system settings menu.

## *i* Information

When **Parking Distance Warning Auto On** is selected, the Parking Safety button indicator (P<sub>SA</sub>) stays on.

## Parking Distance Warning Operation

### Parking Safety button



Press the Parking Safety (P<sub>SA</sub>) button to turn on Forward/Reverse Parking Distance Warning. Press the button again to turn off the function.

- When the gear is shift to R (Reverse), Parking Distance Warning will automatically turn on (Parking Safety button indicator on).

### Forward Parking Distance Warning

Forward Parking Distance Warning will operate under the following conditions.



- The gear is shifted from R (Reverse) to D (Drive) with Reverse Parking Distance Warning on
- The gear is in D (Drive) and the Parking Safety (P<sub>SA</sub>) button indicator light is on
- Shift to D (Drive) when the function is off

(Only when **Setup > Vehicle > Driver Assistance > Parking Safety > Parking Distance Warning Auto On** is selected from the infotainment system settings menu.)

- Shift to R (Reverse) (only front corner warning is on)

## *i* Information

- Forward Parking Distance Warning will operate only when the vehicle's forward speed is below 6 mph (10 km/h).
- Forward Parking Distance Warning is deactivated if the vehicle speed reaches above 18 mph (30 km/h). It will not reactivate although the vehicle speed drops below 6 mph (10 km/h).  
(Only when **Setup > Vehicle > Driver Assistance > Parking Safety > Parking Distance Warning Auto On** is not selected from the infotainment system settings menu.)
- Only the front outer ultrasonic sensor will operate when the gear is in R (Reverse).

Distance from Object	Warning Indicator	Warning Sound
60-100 cm (24-40 in.)		Buzzer beeps intermittently
12-24 in. (30-60 cm)		Beeps more frequently
30 cm (within 12 in.)		Beeps continuously

- The corresponding indicator will illuminate whenever each ultrasonic sensor detects a person, animal or object in its sensing range. Also an audible warning will sound.
- When more than two objects are detected at the same time, the closest one will be warned with an audible warning.
- The shape of the indicator in the illustration may differ from the actual vehicle.

### Side Parking Distance Warning

Side Parking Distance Warning will operate under the following conditions.



- The gear is shifted to R (Reverse).
- The gear is shifted from R (Reverse) to D (Drive).
- The gear is in D (Drive) and the Parking Safety (P) button indicator light is on

- Shift to D (Drive) when the function is off

(Only when **Setup > Vehicle > Driver Assistance > Parking Safety > Parking Distance Warning Auto On** is selected from the infotainment system settings menu.)

### i Information

- Side Parking Distance Warning will operate when the vehicle's forward speed is below 6 mph (10 km/h).
- Side Parking Distance Warning operated only when Forward or Rearward Parking Distance Warning is on.

Distance from Object	Warning Indicator	Warning Sound
24-40 in. (60-100 cm)		-
12-24 in. (30-60 cm)		-
12 in. (within 30 cm)		Beeps continuously



- The corresponding indicator will illuminate whenever each ultrasonic sensor detects a person, animal or object in its sensing range.
- If an object located within 12 in. (30 cm) from the side of the vehicle's path is detected, an audible warning will sound.

- If an object outside the side of the vehicle's path is detected, the warning indicator will be displayed.
- The shape of the indicator in the illustration may differ from the actual vehicle.

### Reverse Parking Distance Warning

Reverse Parking Distance Warning will operate under the following conditions.

- The gear is shifted to R (Reverse).

Distance from Object	Warning Indicator	Warning Sound
24-48 in. (60-120 cm)(Corner: 24-40 in. (60-100 cm))		Buzzer beeps intermittently
12-24 in. (30-60 cm)		Beeps more frequently
12 in. (within 30 cm)		Beeps continuously

- The corresponding indicator will illuminate whenever each ultrasonic sensor detects a person, animal or object in its sensing range. Also an audible warning will sound.
- When more than two objects are detected at the same time, the closest one will be warned with an audible warning.
- The shape of the indicator in the illustration may differ from the actual vehicle.

## Parking Distance Warning Malfunction and Limitations

### Parking Distance Warning malfunction

After starting the vehicle, a beep will sound when the gear is shifted to R (Reverse) to indicate Parking Distance Warning is operating properly.

However, if one or more of the following occurs, first check whether the ultrasonic sensor is damaged or blocked with foreign material. If it still does not work properly, have the vehicle inspected by an authorized HYUNDAI dealer.

- The audible warning does not sound.
- The buzzer sounds intermittently.
- The '**Check Parking Distance Warning system**' warning message appears on the instrument cluster.

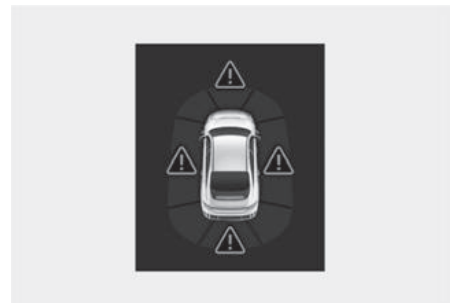
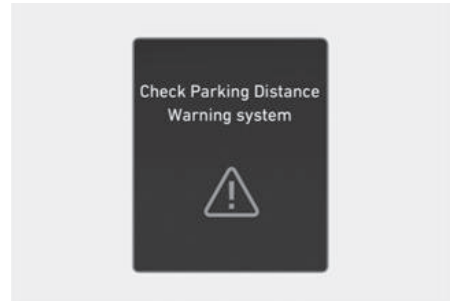

### **Parking Distance Warning disabled**

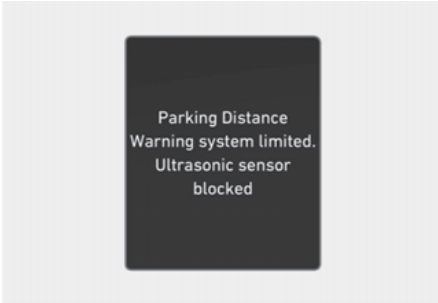

If this occurs the '**Parking Distance Warning system limited. Ultrasonic sensor blocked**' warning message appears on the instrument cluster. Parking Distance Warning will operate properly when snow, rain or foreign material is removed. If Parking Distance Warning does not operate properly after obstruction (snow, rain, or foreign material) is removed (including trailer, carrier, etc., from the rear bumper), have the vehicle inspected by an authorized HYUNDAI dealer.

### **Limitations of Parking Distance Warning**

- Parking Distance Warning may not operate properly when:
  - There is excessive moisture or frost on the sensor
  - Sensor is covered with foreign substance, such as snow or water (Parking Distance Warning will operate properly when such substance is removed.)
  - The weather is extremely hot or cold
  - The sensor or sensor assembly is disassembled
  - The surface of the sensor is pressed hard or hit with a hard object
  - The surface of the sensor is scratched with a sharp object
- The sensors or its surrounding area is directly sprayed with high pressure washer
- Parking Distance Warning may malfunction when:
  - Heavy rain or water spray is present
  - Water flows on the surface of the sensor
  - Affected by another vehicle's sensors
  - The sensor is covered with snow or ice
  - Driving on uneven road, gravel roads or bushes
  - Objects that generate ultrasonic waves are near the sensor
  - License plate is installed in a different spot from the original location
  - The vehicle bumper height or ultrasonic sensor installation has been modified
  - Attaching equipment or accessories next to the ultrasonic sensors
- The following objects may not be detected:
  - Sharp or slim objects, such as ropes, chains or small poles.
  - Narrow objects, such as corners of a square column
  - Objects, which tend to absorb sensor frequency, such as clothes, spongy material or snow.
  - Objects smaller than 40 in. (100 cm) in length and narrower than 6 in. (14 cm) in diameter.
  - Pedestrians, animals or objects that are very close to the ultrasonic sensors
  - An object in the side space between the front corner ultrasonic sensor and the rear corner ultrasonic sensor or an object approaching the side space



## WARNING

- Parking Distance Warning is a supplemental function. The operation of Parking Distance Warning can be affected by several factors (including environmental conditions). It is the responsibility of the driver to always check the front and rear views before and while parking.
- Your new vehicle warranty does not cover any accidents or damage to the vehicle due to the malfunction of Parking Distance Warning.
- Pay close attention when driving near objects, pedestrians, and especially children. Some objects may not be detected by the ultrasonic sensors, due to the objects distance, size or material, all of which can limit the effectiveness of the sensor.
- Parking Distance Warning does not warn you in the order of detection. It varies depending on the speed of the vehicle or the shape of a person, animal, or object.
- If the Parking Distance Warning does not operate properly, have the vehicle inspected by an authorized HYUNDAI dealer.

## Forward/Side/Reverse Parking Collision-Avoidance Assist (PCA)

Forward/Side/Reverse Parking Collision-Avoidance Assist helps detect pedestrians or objects and may warn you or assist you with braking to help avoid a collision while driving at low speed.

### *Detecting sensor*

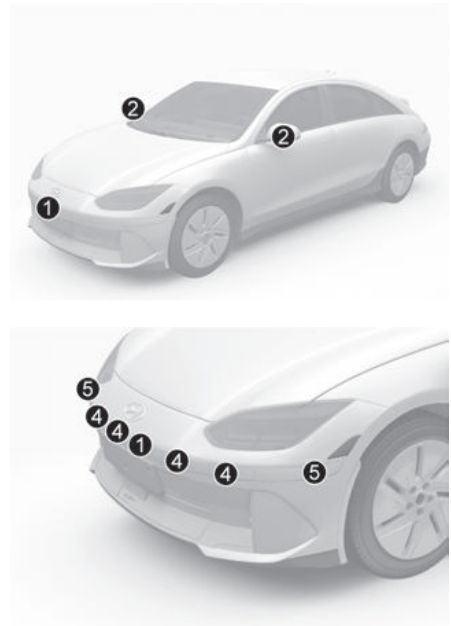

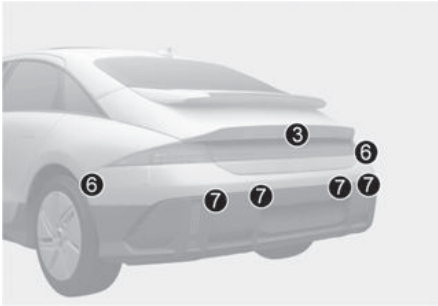

- (1) Wide-front view camera,
- (2) Wide-side view camera (below the side view mirror)
- (3) Wide-rear view camera,
- (4) Front ultrasonic sensors,
- (5) Front side ultrasonic sensors,
- (6) Rear side ultrasonic sensors,
- (7) Rear ultrasonic sensors

Refer to the picture above for the detailed location of the detecting sensors.

## Parking Collision-Avoidance Assist Settings

### **Parking Safety**

With the vehicle on, select or deselect **Setup > Vehicle > Driver Assistance > Parking Safety** from the Settings menu to set whether to use each function.

- If **Forward/Side Safety** is selected, Parking Collision-Avoidance Assist will warn the driver and assist with braking when a collision with a detected pedestrian or an object is imminent from the front or the side.
- If **Rear Safety** is selected, Parking Collision-Avoidance Assist will warn the driver and assist with braking when a collision with a detected pedestrian or an object is imminent from behind.

### **i Information**

**Forward/Side Safety** can be selected only when **Rear Safety** is selected. If the vehicle is restarted, **Rear Safety** is selected and **Forward/Side Safety** maintains the last setting.

## Warning Methods

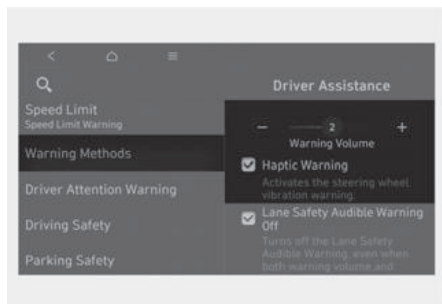

With the vehicle on, go to **Setup > Vehicle > Driver Assistance > Warning Methods** from the Settings in the infotainment system to select the following:

- **Warning Volume:** The Warning Volume can be adjusted.  
If you turn off the **Warning Volume**, for your safety, the function may warn you with a low volume.
- **Haptic Warning:** The steering wheel vibration can be set.

### *i* Information

- If you change the Warning Methods, Warning Methods of other Driver Assistance systems may change.
- If the vehicle is restarted, Warning Methods will maintain the last setting.
- There may be no Settings menu depending on the feature applied to your vehicle.
- The **Warning Volume** and **Haptic Warning** cannot be turned off at the same time. When one of the warnings is turned off, the other is activated.

## Parking Collision-Avoidance Assist Operation



### Turning Parking Collision Avoidance Assist On/Off

Press and hold the Parking Safety (PWA) button more than 2 seconds, to turn the Parking Collision-Avoidance Assist on or off.

### Operating conditions

If Parking Collision-Avoidance Assist detects a risk of collision behind the vehicle with a pedestrian or an object, Parking Collision-Avoidance Assist will warn the driver with an audible warning and warning message on the instrument cluster. If Surround View Monitor is operating, a warning will appear on the infotainment screen.

If collision is imminent, Parking Collision-Avoidance Assist will assist you with braking.

Select **Parking Safety > Rear Safety** from the settings menu.

Parking Collision-Avoidance Assist is enabled when the following conditions are satisfied:

### Rear Safety

- The trunk and door are closed
- The Electronic Parking Brake (EPB) is released
- A trailer is not connected
- The gear is shifted to R (Reverse)
- Vehicle speed is below 6 mph (10 km/h) (detecting pedestrians)
- Vehicle speed is below 2.4 mph (4 km/h) (detecting objects)
- Parking Collision-Avoidance Assist components such as the rear view camera and the rear ultrasonic sensors are in normal conditions

### Front/Side Safety

- **Forward/Side Safety** is selected from the Parking Safety settings menu in the infotainment system.
- The trunk and door are closed
- The Electronic Parking Brake (EPB) is released
- A trailer is not connected
- The gear is shifted to R (Reverse) or D (Drive)
- Vehicle speed is below 2.4 mph (4 km/h) (for pedestrians, objects)
- Parking Collision-Avoidance Assist components such as the rear view camera and the rear ultrasonic sensors are in normal conditions

When Parking Collision-Avoidance Assist activates, a line appears behind the vehicle image in the instrument cluster.

- Rear Safety: Behind the vehicle image
- Front/Side Safety: In front of vehicle image



### *i* Information

Parking Collision-Avoidance Assist operates only once after shifting the gear to R (Reverse) or D (Drive). To reactivate Parking Collision-Avoidance Assist, shift the gear from another gear to R (Reverse) or D (Drive).

### **Off conditions**

#### **Front/Side Safety**

Braking assist is released 2 seconds after shifting to D (Drive) and 5 minutes after shifting to R (Reverse). Immediately depress the brake pedal and check vehicle surroundings.

Braking assist is also released in the following conditions when:

- The gear is shifted to P (Park) or R (Reverse)
- The brake pedal is depressed with sufficient power

### Rear Safety

Braking assist is released after 5 minutes. Immediately depress the brake pedal and check vehicle surroundings.

Braking assist is also released in the following conditions when:

- The gear is shifted to P (Park) or D (Drive)
- The brake pedal is depressed with sufficient power

### *i* Information

When Parking Collision-Avoidance Assist is activated while reversing, braking control will be released after 5 minutes and the Electronic Parking Brake (EPB) will be engaged.

## Parking Collision-Avoidance Assist Malfunction and Limitations

### **Parking Collision-Avoidance Assist malfunction**

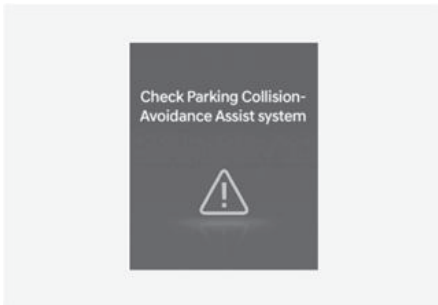

When Parking Collision-Avoidance Assist or other related functions are not working properly, the '**Check Parking Collision-Avoidance Assist system**' warning message will appear on the instrument cluster, and Parking Collision-Avoidance Assist will turn off automatically. Have the vehicle inspected by an authorized HYUNDAI dealer.

### **Parking Collision-Avoidance Assist disabled**

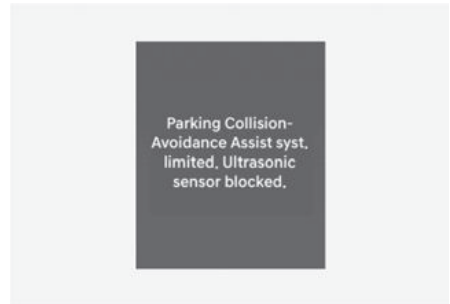
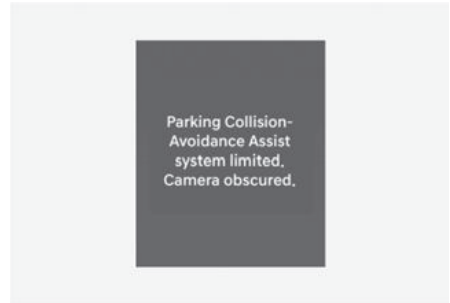

The '**Parking Collision-Avoidance Assist system limited. Camera obscured**' or '**Parking Collision-Avoidance Assist syst. limited. Ultrasonic sensor blocked**' warning message will appear on the instrument cluster if the following situations occur:

- The camera(s) or ultrasonic sensor(s) is covered with foreign material, such as snow or rain, etc.
- There is inclement weather, such as heavy snow, heavy rain, etc.

If this occurs, Parking Collision-Avoidance Assist may turn off or may not operate properly. Check whether the cameras and ultrasonic sensors are clean.

### **Limitations of Parking Collision-Avoidance Assist**

Parking Collision-Avoidance Assist may not assist braking or warn the driver even if there are pedestrians or objects under the following circumstances:

- Problems with vehicle
  - Any non-factory equipment or accessory is installed
  - Your vehicle is unstable due to an accident or other causes
  - Bumper height or rear ultrasonic sensor installation has been modified
  - Wide view camera(s) or ultrasonic sensor(s) is damaged
  - Wide view camera(s) or the ultrasonic sensor(s) is stained with foreign material, such as snow, dirt, etc.
  - Wide view camera(s) is obscured by a light source or by inclement weather, such as heavy rain, fog, snow, etc.
  - Your vehicle height is low or high due to heavy loads, abnormal tire pressure, etc.
- Problems with the surroundings
  - The surrounding is very bright or very dark
  - Outside temperature is very high or very low
  - The wind is either strong (above 12 mph (20 km/h)) or blowing perpendicular to the rear bumper
  - Objects generating excessive noise, such as vehicle horns, loud motorcycle vehicles or truck air brakes, are near your vehicle
  - An ultrasonic sensor with similar frequency is near your vehicle
  - The road is slippery or inclined
  - The image of the pedestrian in the front view camera is indistinguishable from the background
- Problems with pedestrian or object
  - The pedestrians are difficult to detect
  - There is ground height difference between the vehicle and the pedestrian
  - The pedestrian is near the rear edge of the vehicle
  - The pedestrian is not standing upright
  - The pedestrian is either very short or very tall to detect
  - The pedestrian or cyclist is wearing clothing that easily blends into the background, making it difficult to detect
  - The pedestrian is wearing clothing that does not reflect ultrasonic waves well
  - Size, thickness, height, or shape of the object does not reflect ultrasonic waves well (for example, low object, narrow object, circular pillar, small pillar, corners of a square pillar, bush, curbs, carts, edge of a wall, etc.)
  - The pedestrian or the object is moving
  - The pedestrian or the object is very close to the rear of the vehicle
  - There is a large object such as a wall is behind the pedestrian or the object
  - The object is not located at the front or rear center of your vehicle
  - The object is not parallel to the rear bumper
  - The sensors cannot detect the pedestrians and objects
- Problems with driving condition
  - The driver drives the vehicle immediately after shifting to R (Reverse) or D (Drive)
  - The driver accelerates or circles the vehicle

## WARNING

Take the following precautions when using Parking Collision-Avoidance Assist:

- Always exercise extreme caution while driving. The driver is responsible for braking and safe driving.
  - Always pay attention to road and traffic conditions while driving, whether or not there is a warning.
  - Always look around your vehicle to make sure there are no pedestrians or objects before moving the vehicle.
  - The performance of Parking Collision-Avoidance Assist may vary under certain conditions. If vehicle speed is above 2 mph (4 km/h), Parking Collision-Avoidance Assist will provide collision avoidance assist only when pedestrians are detected. Always look around and pay attention when driving your vehicle.
  - Parking Collision-Avoidance Assist may operate differently under certain conditions. If the vehicle moves forward and backward repeatedly, Parking Collision-Avoidance Assist may fail to assist braking or to warn the driver. Always pay attention when driving your vehicle.
  - Some objects may not be detected by the rear ultrasonic sensors due to the objects distance, size or material, all of which can limit the effectiveness of the sensor.
  - Parking Collision-Avoidance Assist may not operate properly or may operate unnecessarily depending on the road conditions and the surroundings.
  - Do not solely rely on Parking Collision-Avoidance Assist. Doing so may lead to vehicle damage or injuries.
- 

## CAUTION

- Noise may be heard when sudden braking occurs to avoid a collision.
  - If any other warning sound such as the seat belt warning chime is already generated, Parking Collision-Avoidance Assist warning may not sound.
  - Parking Collision-Avoidance Assist may not work properly if the bumper has been damaged, replaced or repaired.
  - Parking Collision-Avoidance Assist may not operate properly if interfered by strong electromagnetic waves.
  - Playing the vehicle audio system at high volume may prevent passengers from hearing Parking Collision-Avoidance Assist warning sounds.
  - Turn off Parking Collision-Avoidance Assist when towing a trailer. If towing and moving in reverse, Parking Collision-Avoidance Assist will activate as it detects the trailer.
  - The brake control may not operate properly depending on the status of ESC (Electronic Stability Control).  
There will only be a warning when:
    - The ESC (Electronic Stability Control) warning light is on
    - ESC (Electronic Stability Control) is engaged in a different function
-

### CAUTION

Take the following precautions to maintain optimal performance of the detecting sensors:

- Always keep the wide view cameras and ultrasonic sensors clean.
  - Do not use any cleanser containing acid or alkaline detergents when cleaning the camera lens. Use only a mild soap or neutral detergent, and rinse thoroughly with water.
  - Do not spray the wide view cameras or the rear ultrasonic sensors or their surrounding area directly with a high pressure washer. It may cause the wide angle cameras or the ultrasonic sensors to malfunction.
  - Do not apply objects, such as a bumper sticker or a bumper guard, near the wide angle cameras or ultrasonic sensors or apply paint to the bumper. Doing so may adversely affect the performance of Parking Collision-Avoidance Assist.
  - Never disassemble or apply impact on the wide angle cameras or the ultrasonic sensors components.
  - Do not apply unnecessary force on the wide view cameras or the ultrasonic sensors. Parking Collision-Avoidance Assist may not operate properly if the wide angle cameras or the ultrasonic sensor(s) is forcibly moved out of proper alignment. Have the vehicle inspected by an authorized HYUNDAI dealer.
- 

### Information

Parking Collision-Avoidance Assist can detect a pedestrian or an object when:

- A pedestrian is standing behind the vehicle
  - A large obstacle, such as a vehicle is parked in the rear center of your vehicle
-



## Remote Smart Parking Assist 2 (RSPA 2)

 if equipped

Remote Smart Parking Assist uses the front, front side, rear side, and rear ultrasonic sensors to detect parking spaces and control vehicle steering, speed, gear shifts, and help enter and exit parking spaces remotely from outside your vehicle.

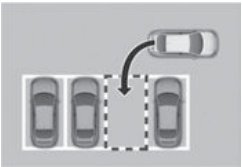
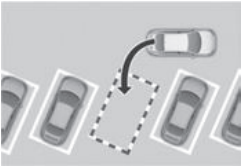
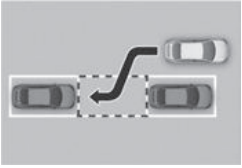
Function	Description
Remote Operation	<p>Remotely moving forward or backward</p> 
Smart Parking or Remote Parking function	<p>Perpendicular reverse parking</p> 
	<p>Diagonal reverse parking</p> 
	<p>Parallel reverse parking</p> 

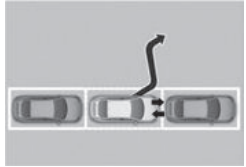
Function	Description
Smart Exit	<p>Parallel forward exit</p> 

- Remote Smart Parking and Remote Operation function may be operated from outside the vehicle using the smart key.
- Smart Parking and Smart Exit function may be operated from inside the vehicle.
- Smart Parking and Remote Parking function helps the driver with perpendicular reverse parking, diagonal reverse parking and parallel reverse parking.
- Smart Exit function helps the driver with parallel forward exit.
- When Remote Smart Parking Assist operates, Parking Distance Warning and Surround View Monitor will also operate. For more information, refer to the "Forward/Side/Reverse Parking Distance Warning (PDW)" and "Surround View Monitor (SVM)" sections in this chapter.
- Remote Smart Parking Assist helps parking by recognizing the parking lines with the wide angle camera.

**Detecting sensors**

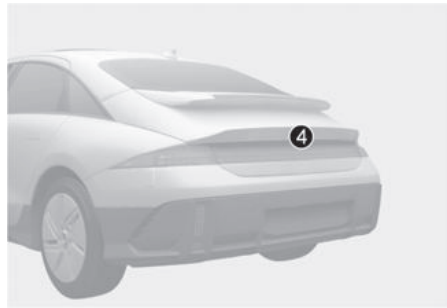
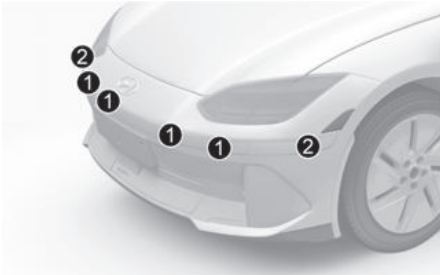

- (1) Wide-front view camera
- (2) Wide-side view camera
- (3) Wide-side view camera
- (4) Wide-rear view camera

Refer to the picture above for the detailed location of the detecting sensors.

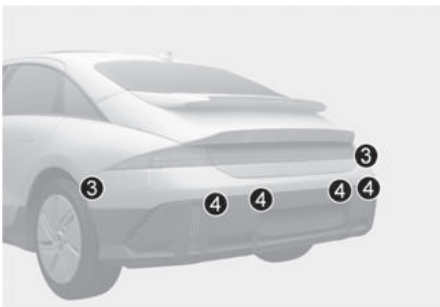

- (1) Front ultrasonic sensors
- (2) Front corner ultrasonic sensors
- (3) Rear corner ultrasonic sensors
- (4) Rear ultrasonic sensors

Refer to the picture above for the detailed location of the detecting sensors.

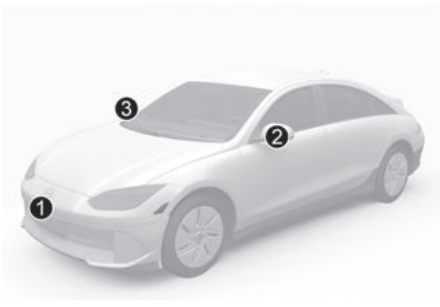

## ⚠ CAUTION

Take the following precautions to maintain optimal performance of the detecting sensors:

- Never disassemble the ultrasonic sensor or sensor assembly, or cause any damage to it.
- Remote Smart Parking Assist may malfunction if the vehicle bumper height or ultrasonic sensor installation has been modified or damaged. Any non-factory installed equipment or accessories may also interfere with the sensor performance.
- When the ultrasonic sensor is frozen or stained with snow, dirt, or water, the sensor may not operate until the stains are removed using a soft cloth.
- Do not push, scratch, or strike the ultrasonic sensor. Sensor damage could occur.
- Do not spray the ultrasonic sensors or its surrounding area directly with a high pressure washer.
- Always keep the camera lens clean. If the lens is covered with foreign material, it may adversely affect camera performance and Remote Smart Parking Assist may not operate properly.
- Do not manually adjust the side view mirror or use Remote Smart Parking Assist after a hard impact on the side view mirror. When a collision occurs or the side view mirror is manually operated, Remote Smart Parking Assist may not operate properly.

## Remote Smart Parking Assist Settings

### Warning Methods

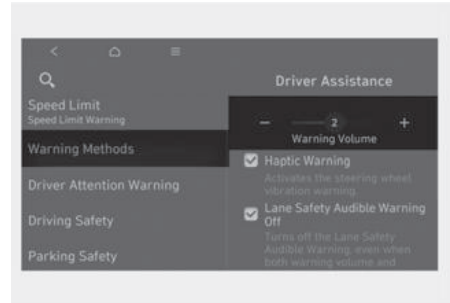

With the vehicle on, go to **Setup > Vehicle > Driver Assistance > Warning Methods** from the Settings in the infotainment system to select the following:

- **Warning Volume:** The Warning Volume can be adjusted.  
If you turn off the **Warning Volume**, for your safety, the function may warn you with a low volume.





### *i* Information

- If you change the Warning Methods, Warning Methods of other Driver Assistance systems may change.
- If the vehicle is restarted, Warning Methods will maintain the last setting.
- There may be no Settings menu depending on the feature applied to your vehicle.

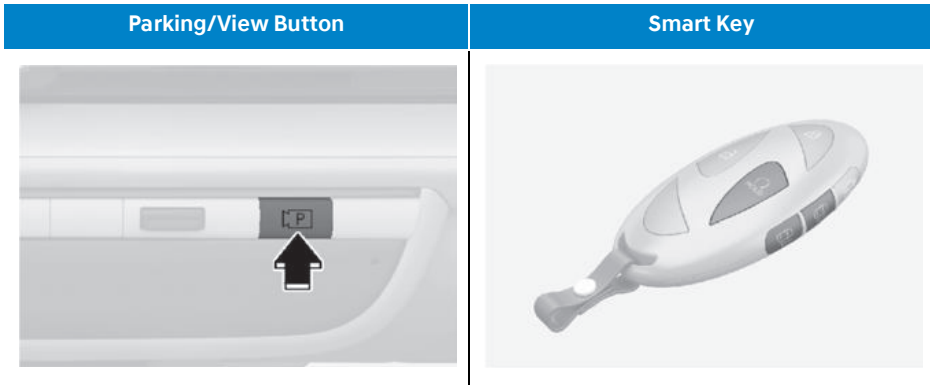
## Remote Smart Parking Assist Operation

### Remote Smart Parking Assist button



Location	Name	Symbol	Description
Inside vehicle	Parking/View button		<ul style="list-style-type: none"> <li>Press and hold the Parking/View button to turn on Remote Smart Parking Assist. Also, Forward/Reverse Parking Distance warning will automatically turn on. However, functions may differ depending on the situations. Refer to the each function's description for more information in the following pages.</li> <li>Press and hold the Parking/View button while Smart Parking or Smart Exit function is on to operate the function.</li> </ul>
Smart key	Remote Start button		<ul style="list-style-type: none"> <li>Press the Remote Start button after the door is locked with the vehicle off to start the vehicle remotely.</li> <li>Press the Remote Start button while Remote Smart Parking or Remote Operation function is operating to end function operation.</li> </ul>
	Forward button		<ul style="list-style-type: none"> <li>When using Remote Parking function, regardless of which direction button is pressed, parking is supported while the button is pressed.</li> </ul>
	Backward button		<ul style="list-style-type: none"> <li>When using the Remote Operation function, the vehicle moves in the direction of the button while the button is pressed.</li> </ul>

## Remote Operation

### Operating order

Remote Operation operates in the following order:

1. Getting ready to remotely move forward and backward
2. Remotely moving forward and backward

### 1. Getting ready to remotely move forward and backward

There are two ways to operate Remote Operation function.



Method 1. Using the function with vehicle off

- Within a certain range from the vehicle press the door lock (🔒) button on the smart key and lock all doors.
- Press and hold the Remote Start button (🚗) within 4 seconds until the vehicle starts.

For more information on remotely starting the vehicle, refer to the "Remote Start" section in chapter 6.

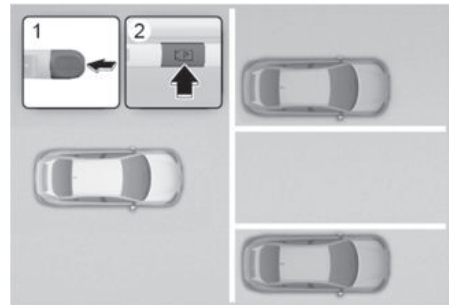

Method 2. Using the function with vehicle on

1. Park the vehicle in front of the space where you want to use Remote Operation function, and shift the gear to P (Park).
2. Press and hold the Parking/View (🚗) button to turn on Smart Parking Assist.
  - A message **Remote Parking instructions** will appear on the infotainment system.
3. Get out of the vehicle with the smart key and close all doors.

## **i** Information

- **Agree** must be selected on the infotainment system and the infotainment system has to operate properly to use Remote Operation function.
- Method 2 can be used after the vehicle has been driven above 3 mph (5 km/h).
- If the function is turned on again after parking is completed by Remote Smart Parking Assist, Remote Operation function can be used with Method 2.

### **2. Remotely moving forward and backward**

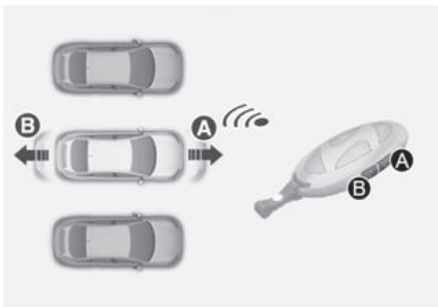

1. Press and hold one of the Forward (A) or Backward (B) button on the smart key.
  - Remote Smart Parking Assist will automatically control the steering wheel, vehicle speed and gearshift. The vehicle will move in the direction of the button pressed.
  - While Remote Operation function is operating, if you let the button, the vehicle will stop and function control will pause. The function will start operating again when the button is pressed and held again.
2. Hold down the Forward (A) or Backward (B) button until the vehicle reaches the target location.
3. When Remote Operation is done, get in the vehicle with the smart key or press the Remote Start (C) button on the smart key from outside the vehicle.
  - The message will appear on the infotainment system. The vehicle will automatically shift to P (Park) and engage the parking brake.
  - When the Remote Start (C) button is pressed, the vehicle will turn off. If the driver is in the vehicle, the vehicle will retain ON position.

## **i** Information

- Remote Operation can control the vehicle remotely using the smart key outside the vehicle.
- Check that all smart keys are outside the vehicle when using Remote Operation function.
- Remote Operation function will operate only when the smart key is within 13 ft. (4 m) from the vehicle. If there is no vehicle movement even when the Forward or Backward button is pressed on the smart key, check the distance to the vehicle and press the button again.
- The detecting range of the smart key may vary depending on the surroundings that are affected by radio waves such as transmission tower, broadcast station, etc.
- When remotely moving forward using Method 1, it is recognized as an exit situation, and the vehicle moves 13 ft. (4 m) to check for parking lines, pedestrians, animals or objects around the vehicle. After confirmation, the steering wheel is controlled according to the condition ahead.

- When remotely moving forward using Method 2, it is recognized as a parking situation, and will immediately control the steering wheel according to the condition ahead to assist with entering the parking space and aligning the vehicle. However, performance may reduce depending on the parking lines, pedestrians, animals, shape of objects, location, etc., around the vehicle.
- For moving remotely backward, both Method 1 and 2 aligns the steering wheel first, and then will only move the vehicle straight.

### WARNING

- When using Remote Operation function, make sure that all passengers have gotten out of the vehicle.
- If the vehicle's battery is discharged or Remote Smart Parking Assist malfunctions when parked in a narrow parking space, Remote Operation function will not operate. Always park your vehicle in a space wide enough for you to get in or out of your vehicle.
- Please note that depending on the parking space, you may not be able to exit from the space you have entered by using Remote Operation function.
- After parking, the surrounding may change due to the movement of surrounding vehicles. If this occurs, Remote Operation function may not operate.
- Before leaving the vehicle, close windows and sunroofs, and make sure the vehicle is off before locking the doors.



### Remote Operation function operation status

Operation Status	Smart Key LED	Hazard Warning Light
Under control	Green LED continuously blinks	-
Pause	Red LED continuously blinks	Blinks
Off	Red LED illuminates for 4 seconds and then turns off	Blinks 3 times and turns off
Complete	Green LED illuminates for 4 seconds and then turns off	Blinks 1 time and turns off

### Information

- Operation status by the hazard warning light may not be applicable based on the regulation of your state.
- If the smart key is not within the operating range from the vehicle (about 13 ft. (4 m)), the smart key LED will not illuminate or blink. Use the smart key within the operating range.

### How to turn off Remote Operation function while operating

- Press the Parking/View () button while the infotainment system guides the driver using method 2.
- Shift the gear from P (Park) to any other position while the infotainment system guides the driver using method 2.
- Press the Parking Safety () button or select **Cancel** on the infotainment system.

- Press the Remote Start (🔑) button on the smart key while the vehicle is being controlled by Remote Operation function. Remote Operation function will turn off. At this time, the vehicle will turn off.
- Get on the vehicle with the smart key. Remote Operation function will turn off. At this time, the vehicle will remain on.

### **The function will pause in the following conditions when:**

- There is a pedestrian, animal or object in the direction the vehicle is moving
  - The door or trunk is open
  - The Forward (⏩) or Backward (⏪) button is not continuously pressed
  - Simultaneously pressing multiple buttons on a smart key
  - The smart key is not operated within 13 ft. (4 m) from the vehicle
  - Button of another smart key is pressed in addition to the operating smart key (except Remote Start button)
  - Parking Collision-Avoidance Assist or Rear Cross-Traffic Collision-Avoidance Assist operates while the vehicle is being controlled in the reverse direction.
  - The vehicle moves 22 ft. (7 m) while the smart key is pressed with Remote Operation function (maximum travel distance per button press)
- The function will cancel in the following conditions when:**
- When Remote Operation function is canceled, the vehicle will automatically stop, shift the gear to P (Park) and engage EPB (Electronic Parking Brake).
- The steering wheel is steered
  - The gear is shifted while the vehicle is moving
  - Operating EPB while the vehicle is moving
  - The hood is open
  - The brake pedal or accelerator pedal is depressed when all the doors are closed
  - The smart key is outside the vehicle when the brake pedal is depressed while the driver's door is open
  - Rapid acceleration occurs
  - Vehicle skid occurs
  - The wheel is stuck by an obstacle and cannot move
  - About 3 minutes and 50 seconds has passed after Remote Operation function has started to operate
  - The slope of the road exceeds the operational range
  - The function is paused for more than 1 minute
  - The total travel distance of the vehicle has exceeded 45 ft. (14 m) after Remote Operation function operation
  - The steering wheel, gearshift, braking, and drive controls are not working properly
  - There is a problem with the smart key or the smart key battery is low
  - ABS, TCS or ESC system operates due to slippery road conditions
  - The alarm of the Theft Alarm System sounds
  - The charging door is open



## Smart Parking, Remote Smart Parking

The parking function includes Smart Parking using the Parking/View (P) button and Remote Smart Parking using a smart key.

### Operating order

Parking function operates in the following order:

1. Getting ready for parking
2. Searching for parking space
3. Select parking type and operating mode
4. Smart Parking
5. Remote Smart Parking

### 1. Getting ready for parking



1. With the vehicle turned on, depress the brake pedal and shift the gear to D (Drive) or N (Neutral).
2. Press and hold the Parking/View (P) button to turn on Remote Smart Parking Assist.

#### **i** Information

- **Agree** must be selected on the infotainment system and the infotainment system has to operate properly to use Parking function.

- If you drive above 3 mph (5 km/h) with the vehicle on, you may use the Parking function with the gear shifted to N (Neutral).

### 2. Searching for parking space



Slowly drive forward maintaining the distance of about 40 in. (100 cm) from the parked vehicles.

Searches for a parking space by detecting the parking lines or the spaces next to or in front and behind the parked vehicles.

When searching for a parking space is complete, a message will appear on the infotainment system with an audible sound to notify the search is complete.

**Select Parking Type** will be displayed on the infotainment system and the selected parking space will appear on Top View screen of Surround View Monitor.

#### **i** Information

- Remote Smart Parking Assist can only search for parking spaces when parking lines are visible or when there are parked vehicles, and the empty spaces created after driving or the empty spaces in front of a vehicle that has not yet been driven cannot be searched as the a parking space.
- While searching for a parking space, when vehicle speed is above 12 mph (20 km/h), a message will appear on the infotainment system informing you to slow down. When vehicle speed is above 18 mph (30 km/h), Parking function will turn off.

- Searching for a parking space will be completed when there is enough space to move the vehicle in addition to the parking space.
- Even if an audible sound is heard to notify that searching for a parking space is complete, search completion can be cancelled immediately depending on surroundings.

### *i* Information

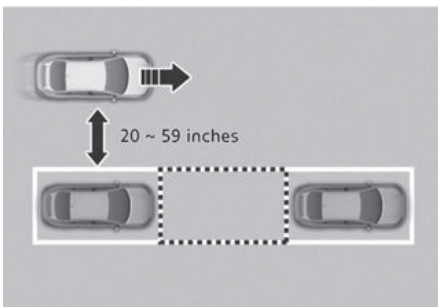

- If the distance is below 20 in. (50 cm) or over 59 in. (150 cm), Remote Smart Parking Assist may not be able to search for a parking space.
- If you do not maintain a certain distance from the parked vehicle, the performance to search for a parking space may reduce.
- Due to abnormal performance of the ultrasonic sensor or the influence of the surroundings, Parking function may not be able to search for a parking space even if there is a parking space, or may search for a space that is not suitable for parking.
- If the parking space is on an incline or is diagonal, the parking type displayed may be different from the actual parking type which should be selected. If this occurs, do not select the parking type, and search for another parking space.

### 3. Select parking type and operating mode



- Parking type - Perpendicular reverse (Left/Right), Parallel reverse (Left/Right)  
With the vehicle stopped by depressing the brake pedal, touch the infotainment system to select the desired parking type.

### *i* Information

- If you continue to drive without stopping after the parking type selection screen appears, Remote Smart Parking Assist will return to the previous stage and search for a parking space.
- If Parking function is cancelled unintentionally by pressing the Parking/View () button before the parking type is selected, you can return to the parking type selection stage by pressing and holding the button again while the vehicle is stopped.

### WARNING

Before selecting the Parking type, the driver should check whether the parking space is suitable.

If the searched parking space by Remote Smart Parking Assist is narrow or unsuitable for parking, do not select the Parking type and move the vehicle to search for another parking space.

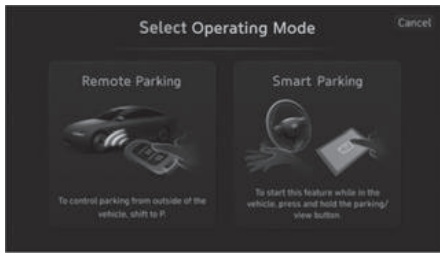

- Operating mode - Remote Parking, Smart Parking

After selecting a parking type, the infotainment system will guide you with Remote Parking function and Smart Parking function. Follow the instructions to operate Remote Smart Parking Assist.

### *i* Information

- Operating instructions will be displayed on the screen for each desired function you select.
- Do not take your foot off the brake pedal during the Parking function guide. When the vehicle moves, Remote Smart Parking Assist will turn off.

### *i* Information



If Remote Smart Parking Assist cannot activate Remote Parking function, only the Smart Parking guide will be displayed on the infotainment system.

## 4. Smart Parking

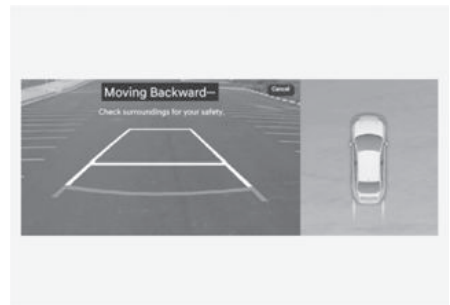
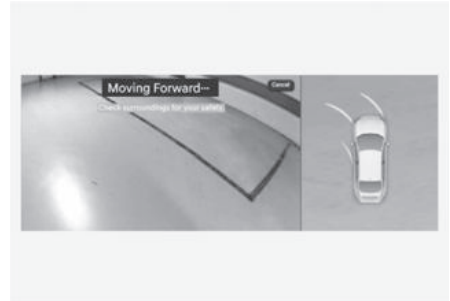

1. Press the Parking/View (**P**) button when the vehicle is stopped by depressing the brake pedal.
2. Release the brake pedal while pressing the Parking/View (**P**) button.
  - Remote Smart Parking Assist will automatically control the steering wheel, vehicle speed and gearshift.
  - While Smart Parking function is operating, if you do not hold down the Parking/View (**P**) button, the function will stop and function control will pause. The function will start operating again when the Parking/View (**P**) button is pressed and held again.

3. Press and hold the Parking/View (P) button until parking is completed.
  - When the vehicle reaches the target parking position, a message will appear on the infotainment system to inform you that parking is complete. The vehicle will automatically shift to P (Park) and engage EPB (Electronic Parking Brake).
4. If you need to change the vehicle's position or location, manually complete parking your vehicle.

### **i** Information

- Smart Parking function will not operate if the door is open or the seat belt is not fastened.
- The parking location indicator is displayed on Surround View Monitor screen and is displayed until the vehicle enters the parking space for the first time by Smart Parking function.
- Vehicle speed can be adjusted by depressing the brake pedal while Smart Parking function is operating. However, the vehicle does not accelerate even when the accelerator pedal is depressed.
- Depending on parking environments, if the vehicle is stopped by a stopper, parking may be completed.

## 5. Remote Smart Parking



1. Depress the brake pedal and shift the gear to P (Park).
2. Get out of the vehicle with the smart key, and close all doors.
3. Press one of the Forward (F) or Backward (B) button on the smart key.
  - While pressing the button, Remote Smart Parking Assist will automatically control the steering wheel, vehicle speed and gearshift.
  - While Remote Parking function is operating, if you do not hold down the button, the vehicle will stop and function control will pause. The function will start operating again when the button is pressed and held again.
4. Press and hold the Forward (F) or Backward (B) button until parking is completed.
  - When the vehicle reaches the target parking position, a message will appear on the infotainment system to inform you that parking is complete. The vehicle will automatically shift to P (Park), engage EPB (Electronic Parking Brake) and the vehicle will turn off.

5. If you need to change the vehicle's position or location, manually complete parking your vehicle.

### Information

- When operating Remote Parking function, make sure all smart keys are outside of the vehicle.
  - Remote Parking function will operate only when the smart key is within 13 ft. (4 m) from the vehicle. If there is no vehicle movement even when the Remote Forward or Backward button is pressed on the smart key, check the distance to the vehicle and press the button again.
  - The detecting range of the smart key may vary depending on the surroundings that are affected by radio waves such as transmission tower, broadcast station, etc.
  - The parking location indicator is displayed on Surround View Monitor screen and is displayed until the vehicle enters the parking space for the first time by Remote Parking function.
  - Depending on parking environments, if the vehicle is stopped by a stopper, parking may be completed.
- 

### WARNING

- When using Remote Parking function, make sure that all passengers have gotten out of the vehicle.
  - After ending or turning off Remote Parking function, before leaving the vehicle, close windows and sunroofs, and make sure the vehicle is off before locking the doors.
-

**Parking function operation status**

- Smart Parking function

Operation Status	Turn Signal
Under control	The turn signal of the parking direction blinks until the first reverse is complete.

- Smart Parking function

Operation Status	Smart Key LED	Hazard Warning Light	Turn Signal
Under control	Green LED continuously blinks	-	The turn signal of the parking direction blinks until the first reverse is complete.
Pause	Red LED continuously blinks	Blinks	-
Off	Red LED illuminates for 4 seconds and then turns off	Blinks 3 times and turns off	-
Complete	Green LED illuminates for 4 seconds and then turns off	Blinks 1 time and turns off	-

***i* Information**

- Operation status by the hazard warning light and turn signal may not be available based on the regulation of your state.
- If the smart key is not within the operating range from the vehicle (about 13 ft. (4 m)), the smart key LED will not illuminate or blink. Use the smart key within the operating range.

### **How to turn off Parking function while operating**

- Press the Parking/View (P) button in the following stage:
  - Searching for parking space
  - Select parking type
- Shift the gear to R (Reverse) in the following stage:
  - Searching for parking space
  - Select parking type
  - Select operating mode
- Press the Parking Safety (P) button or select **Cancel** on the infotainment system to turn off Parking function.
- While Smart Parking function is operating:
  - If the vehicle is stopped by depressing the brake pedal, and the gear is shifted, Parking function will turn off. At this time, EPB (Electronic Parking Brake) will not be engaged.
- While Remote Parking function is operating:
  - Press the Remote Start (R) button on the smart key. Parking function will turn off.

### **i Information**

Get on the vehicle with the smart key. Parking function will turn off. At this time, the vehicle will remain on.

### **The function will pause in the following conditions when:**

- Smart Parking
  - There is a pedestrian, animal or object in the direction the vehicle is moving
  - The door or trunk is open
  - The driver's seat belt is not fastened
  - Parking Collision-Avoidance Assist or Rear-Cross Traffic Collision-Avoidance Assist operates while the vehicle is being controlled in the reverse direction
  - The Parking/View (P) button is not continuously pressed
  - The vehicle is stopped by depressing the brake pedal
- Remote Smart Parking
  - There is a pedestrian, animal or object in the direction the vehicle is moving
  - The door or trunk is open
  - The Forward (F) or Backward (B) button is not continuously pressed
  - Simultaneously pressing multiple buttons on a smart key
  - The smart key is not operated within 13 ft. (4 m) from the vehicle
  - Button of another smart key is pressed in addition to the operating smart key
  - Parking Collision-Avoidance Assist, Rear-Cross Traffic Collision-Avoidance Assist, or Parking Collision-Avoidance Assist operates

When Parking function is paused, the vehicle will automatically stop. If the condition that made the function to pause disappears, the function may operate again.

***The function will cancel in the following conditions when:***

- Smart Parking
  - The steering wheel is steered
  - The gear is shifted while the vehicle is moving
  - Operating EPB while the vehicle is moving
  - The hood is open
  - The driver opens the door with the seatbelt unfastened
  - Rapid acceleration occurs
  - Vehicle skid occurs
  - The wheel is stuck by an obstacle and cannot move
  - There are pedestrians, animals or objects at the front and rear of the vehicle at the same time
  - About 3 minutes and 50 seconds have past after Smart Parking function has started to operate
  - The slope of the road exceeds the operational range
  - The function is paused for more than 1 minute
  - The steering wheel, gearshift, braking, and drive controls are not working properly
  - ABS, TCS or ESC system operates due to slippery road conditions
  - The charging door is open

When Smart Parking function is canceled, the vehicle will automatically stop, shift the gear to P (Park) and engage EPB (Electronic Parking Brake).

- Remote Smart Parking
  - The steering wheel is steered
  - The gear is shifted
  - Operating EPB while the vehicle is moving
  - The hood is open
  - The brake pedal or accelerator pedal is depressed when all the doors are closed
  - The smart key is outside the vehicle when the brake pedal is depressed while the driver's door is open
  - Rapid acceleration occurs
  - Vehicle skid occurs
  - The wheel is stuck by an obstacle and cannot move
  - There are pedestrians, animals or objects at the front and rear of the vehicle at the same time
  - About 3 minutes and 50 seconds have past after Remote Parking function has started to operate
  - The slope of the road exceeds the operational range
  - The function is paused for more than 1 minute
  - The steering wheel, gearshift, braking, and drive controls are not working properly
  - There is a problem with the smart key or the smart key battery is low
  - ABS, TCS or ESC system operates due to slippery road conditions
  - The alarm of the Theft Alarm System sounds
  - The charging door is open

When Remote Parking function is canceled, the vehicle will automatically stop, shift the gear to P (Park) and engage EPB (Electronic Parking Brake).



## Smart Exit

### Operating order

Smart Exit function operates in the following order:

1. Getting ready for exit
2. Checking space
3. Select exit direction
4. Smart Exit

### 1. Getting ready for exit



1. With the vehicle turned on, depress the brake pedal and shift the gear to P (Park) or N (Neutral).
2. Press and hold the Parking/View (P) button to turn on Remote Smart Parking Assist.

### *i* Information

- **Agree** must be selected on the infotainment system and the infotainment system has to operate properly to use Smart Exit function.
- Drive below 3 mph (5 km/h) with the vehicle on and shift the gear to P (Park) or N (Neutral), Smart Exit function can be used.
- If the function is turned on again after parallel parking is completed by Remote Smart Parking Assist, Smart Exit function can be used.

### 2. Checking space



When the vehicle is stopped by depressing the brake pedal, the vehicle sensors will detect the distance from nearby objects and check for space to exit.

When checking for space is complete, a message will appear on the infotainment system with an audible sound to notify the search is complete.

### **!** WARNING

- While checking for space, if there is a risk of collision with pedestrian, animal or object in the direction of vehicle exit, for your safety, Smart Exit function can be turned off.
- Even if check for space is completed, objects in the blind spot area cannot be detected by the sensors. The driver must directly check the blind spot area and continue using the function.

### *i* Information

Due to abnormal performance of the ultrasonic sensor or the influence of the surroundings, Parking function may not be able to search for a parking space even if there is a parking space, or may search for a space that is not suitable for parking. For more information, refer to the "Limitations of Remote Smart Parking Assist" section in this chapter.

### 3. Select exit direction



With the vehicle stopped by depressing the brake pedal, touch the infotainment system to select the desired exit direction.



#### WARNING



Before selecting the Exit Direction, the driver should check whether the space for exit is suitable.

If the searched exit space by Remote Smart Parking Assist is narrow or unsuitable (surrounding vehicles are parked vertically, etc.), do not use the Smart Exit function.

### 4. Smart Exit



1. Press the Parking/View () button when the vehicle is stopped by depressing the brake pedal.
2. When the Parking/View () button is pressed, release the brake pedal according to the instructions.
  - Remote Smart Parking Assist will automatically control the steering wheel, vehicle speed and gearshift.

- While Smart Exit function is operating, if you do not hold down the Parking/View () button, the vehicle will stop and function control will pause. The function will start operating again when the Parking/View () button is pressed and held again.

3. Press and hold the Parking/View () button until exiting is completed.

- When the vehicle reaches the target exit location, a message will appear on the infotainment system to inform you that exit is completed.

#### Information

- Smart Exit function will not operate if the door is open or the seat belt is not fastened.
- Vehicle speed can be adjusted by depressing the brake pedal while Smart Exit function is operating. However, the vehicle does not accelerate even when the accelerator pedal is depressed.
- If exit is completed while depressing the brake pedal, Smart Exit function will complete with the gear in D (Drive).
- If exit is completed while depressing the accelerator pedal, you must take your foot off the accelerator pedal once for the accelerator pedal to operate.
- If there is no vehicle operation such as depressing the brake pedal or accelerator pedal within 4 seconds after exit is complete, the vehicle will automatically shift to P (Park) and engage EPB (Electronic Parking Brake).
- After Exit function is complete, always check the surroundings before driving.

### Smart Exit operation status

Operation Status	Turn Signal
Under control	The turn signal of the exit direction blinks until the exit is complete or Smart Exit is canceled.

### How to turn off Smart function while operating

- Press the Parking/View (P) button in the following stage:
  - Checking space
  - Select exit direction
- Shift the gear to R (Reverse) in the following stage:
  - Checking space
  - Select exit direction
- Press the Parking Safety (P) button or select **Cancel** on the infotainment system to turn off Exit function.
- While Smart Exit function is operating, if the vehicle is stopped by depressing the brake pedal, and the gear is shifted, Exiting function will turn off. At this time, EPB (Electronic Parking Brake) will not be engaged.

### The function will pause in the following conditions when:

- There is a pedestrian, animal or object in the direction the vehicle is moving
- The door or trunk is open
- The driver's seat belt is not fastened
- Parking Collision-Avoidance Assist or Rear-Cross Traffic Collision-Avoidance Assist operates while the vehicle is being controlled in the reverse direction
- The Parking/View (P) button is not continuously pressed
- The vehicle is stopped by depressing the brake pedal

When Exit function is paused, the vehicle will stop. If the condition that made the function to pause disappears, the function may operate again.

### The function will cancel in the following conditions when:

- Smart Exit
  - The steering wheel is steered
  - The gear is shifted while the vehicle is moving
  - Operating EPB while the vehicle is moving
  - The hood is open
  - The driver opens the door with the seatbelt unfastened
  - Rapid acceleration occurs
  - Vehicle skid occurs
  - The wheel is stuck by an obstacle and cannot move
  - There are pedestrians, animals or objects at the front and rear of the vehicle at the same time
  - About 3 minutes and 50 seconds have past after Smart Exit function has started to operate
  - The slope of the road exceeds the operational range
  - The function was paused for more than 1 minute
  - The steering wheel, gearshift, braking, and drive controls are not working properly
  - ABS, TCS or ESC system operates due to slippery road conditions
  - The charging door is open

When Smart Exit function is canceled, the vehicle will automatically stop, shift the gear to P (Park) and engage EPB (Electronic Parking Brake).

## Remote Smart Parking Assist Malfunction and Limitations

### Remote Smart Parking Assist malfunction

#### Remote Smart Parking Assist check



When Remote Smart Parking Assist is not working properly, the '**Check Parking Assist**' warning message will appear on the infotainment system. If the message appears, stop using Remote Smart Parking Assist, and have the vehicle inspected by an authorized HYUNDAI dealer.

#### Remote Smart Parking Assist canceled

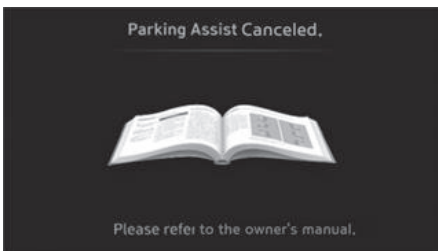

When Remote Parking Assist is operating, the function can be canceled, and the '**Parking Assist Canceled**' warning message may appear regardless of the parking order. Other messages may appear depending on the situations. Follow the instructions provided on the infotainment system while parking your vehicle with Remote Parking Assist. Always look around and pay attention when using Remote Smart Parking Assist.

#### Remote Smart Parking Assist standby



The '**Parking Assist Conditions Not Met**' message will appear in the following circumstances:

- When '**Parking Assist Conditions Not Met**' message appears when Parking/View (P) button has been pressed and held while Remote Smart Parking Assist is in standby. After a while, press and hold the Parking/View (P) button again to see if Remote Smart Parking Assist works.
- When the smart key's battery is low. Check the smart key battery level.
- It does not work even when the EV mode is in the Utility mode. For related information, refer to the "Setting Utility Mode" section in chapter 1.

#### Limitations of Remote Smart Parking Assist

In the following circumstances, Remote Smart Parking Assist performance to park or exit the vehicle may be limited, there may be a risk of collision, or Remote Smart Parking Assist may turn off. Park or exit the vehicle manually if necessary.

- An object is attached to the steering wheel
- The vehicle is installed with a snow chain, spare tire or different size wheel
- Tire pressure is lower or higher than the standard tire pressure
- Your vehicle is loaded with cargo longer or wider than your vehicle or a trailer is connected to your vehicle

- There is a problem with the wheel alignment
- Your vehicle is leaned severely to one side
- Your vehicle is equipped with a trailer hitch
- The license plate is installed differently from the original location
- There is a person, animal or object above or below the ultrasonic sensor when Remote Smart Parking Assist is activated
- The parking space is curved or diagonal
- There is an obstacle such as a person, animal or object (trash can, bicycle, motorcycle, shopping cart, narrow pillar, etc.) near the parking space
- There is a circular pillar or narrow pillar, or a pillar surrounded by objects such as fire extinguisher, etc., near the parking space
- The road surface is bumpy (curbstone, speed bump, etc.)
- The road is slippery
- The parking space is near a vehicle with higher ground clearance or big, such as a truck, etc.
- The parking space is Inclined
- The road surface of parking space with lines is wet due to snow, puddles, or there is a road marker inside the parking space
- The road surface of the parking space with lines is bumpy due to road cracks
- The parking line is too thin or thick
- The parking line is partially erased or blurred
- The parking line is obscured by people, animals, or objects such as snow, boxes, etc.
- There is heavy wind
- Operating Remote Smart Parking Assist on uneven roads, gravel roads, bushes, etc.
- The performance of the ultrasonic sensor is affected by extremely hot or cold weather
- The ultrasonic sensor is covered with snow or water
- An object that generates ultrasonic waves is nearby
- A wireless device with a transmission function operates near the ultrasonic sensors
- Your vehicle is affected by another vehicle's Parking Distance Warning
- The sensor is mounted or positioned incorrectly by an impact to the bumper
- The cameras is improperly mounted or out of position due to side view mirror damage
- The ultrasonic sensor cannot detect the following objects when:
  - Sharp or slim objects, such as ropes, chains or small poles
  - Objects smaller than 40 in. (100 cm) in length and narrower than 6 in. (14 cm) in diameter
  - Objects which tend to absorb sensor frequency, such as clothes, spongy material or snow
  - A narrow object such as a corner of a square pillar
  - Person, animal or object near the ultrasonic sensor
- The cameras may not properly recognize or may not recognize the parking line and objects when:
  - There are small objects (curb, etc.), sharp objects, or thin objects (rope, etc.) around
  - People, animals or objects are too close or too far from the vehicle
  - Objects are on a higher position, such as pickup trucks
  - The camera is obscured by dirt or moisture
  - The camera is exposed to bright light

- The surrounding is too dark
- The light is reflected from the surface

Remote Smart Parking Assist may not operate properly under the following circumstances:

- Parking on inclines



Park or exit manually when the vehicle is on inclines.

- Parking on uneven road



Remote Smart Parking Assist may cancel when the vehicle slips, or the vehicle cannot move due to road conditions such as pebbles or fragmented stones.

- Parking behind a truck



Do not use Remote Smart Parking Assist around vehicles with higher ground clearance, such as a bus, truck, etc. It may lead to an accident.

- Parking near a pillar

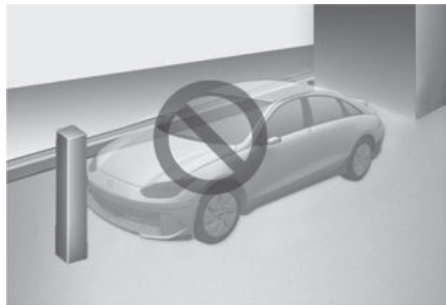

Remote Smart Parking Assist performance may reduce or collision with an obstacle may occur when there is a narrow object, circular pillar, square pillar, or a pillar surrounded by objects such as a fire extinguisher, etc., near the parking space. The driver should park the vehicle manually.

- Parking next to a misaligned vehicle

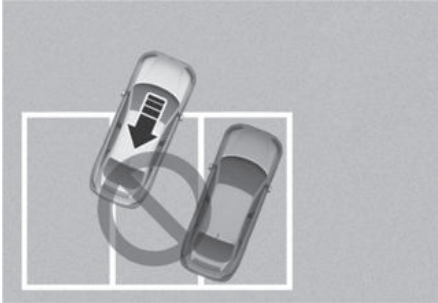

If Remote Smart Parking Assist is used when parking in a space next to misaligned vehicles, your vehicle may not be parked side by side.

However, if there is a parking line and it is detected properly, your vehicle will park side by side with the parking line.

- Leaving a parking space near a wall or parking in a narrow space

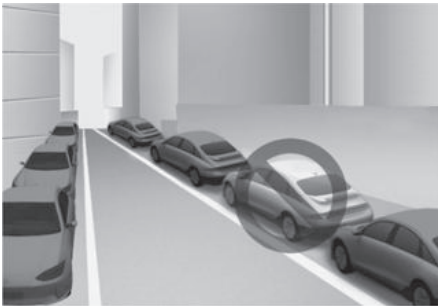

- Remote Smart Parking Assist may not operate properly when leaving a parking space that is narrow and near a wall. Always check for pedestrians, animals, objects while leaving.

- For your safety, Remote Smart Parking Assist does not search for parking spaces at areas with narrow parking spaces that are narrower than the minimum space required for parking.

Remote Smart Parking Assist may not operate properly when parking in a narrow space. Always check for pedestrians, animals, objects while parking.

- Parking in snow



Snow may interfere with the operation of the ultrasonic sensor and wide view camera, or Remote Smart Parking Assist may cancel if the road is slippery while parking.

- Abnormal parking space

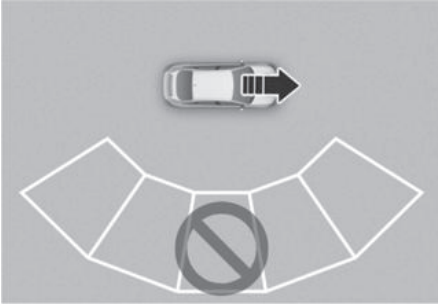

Remote Smart Parking Assist does not work properly when the parking lines are not parallel. Do not park although the parking space is recognized by the sensor.

- Inclined parking space

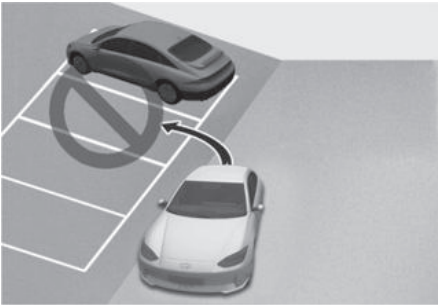

Remote Smart Parking Assist does not work properly on a inclined or curved road surface. Do not park although the parking space is recognized by the sensor.

- Parking diagonal

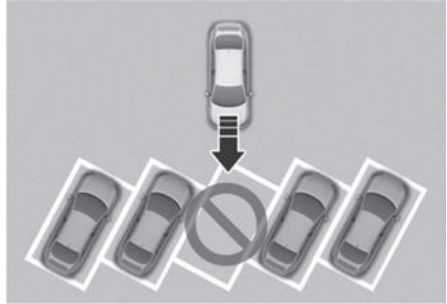

Remote Operation function may not operate properly in a diagonal parking space.



## WARNING

Take the following precautions when using Remote Smart Parking Assist:

- The driver is responsible for safe parking and exit when using Remote Smart Parking Assist.
- When using Remote Smart Parking Assist, stay out of the way in the direction the vehicle moves for your safety.
- Always check surroundings when using Remote Smart Parking Assist. You may collide with pedestrians, animals, or objects if they are near the sensor or are in the sensor's blind spot area.
- A collision may occur if a pedestrian, animal, or object suddenly appears while Remote Smart Parking Assist is operating.
- Do not use Remote Smart Parking Assist when under the influence of alcohol.
- Do not let children or other people to use the smart key.
- If Remote Smart Parking Assist is used continuously for a long period, it may adversely affect Remote Smart Parking Assist performance.
- Remote Smart Parking Assist may not operate properly if the vehicle needs wheel alignment adjustment such as when the vehicle tilts to one side. Have the vehicle inspected by an authorized HYUNDAI dealer.
- Noise may be heard when braking occurs by Remote Smart Parking Assist or when the brake pedal is depressed by the driver.
- Remote Smart Parking Assist may suddenly apply the brake to avoid collision with pedestrian, animal, or object.

- Use Remote Smart Parking Assist only in a parking space that is large enough for the vehicle to move safely.
- If Remote Smart Parking Assist does not operate properly, have the vehicle inspected by an authorized HYUNDAI dealer.

## NOTICE

- If the 3rd stage warning (continuous beep) of the Forward/Reverse Parking Distance Warning sounds while Remote Smart Parking Assist is operating, it means the obstacle detected is close to your vehicle. At this time, Remote Smart Parking Assist will temporarily stop operating. Make sure there are no pedestrians, animals, or objects around your vehicle.
- Depending on brake operation, the stop lights may come on while the vehicle is moving.
- If the vehicle is remotely started that has been parked in cold weather for a long time, the operation of Remote Parking function may be delayed or canceled depending on vehicle condition.

## Declaration of Conformity

### Front Radar

The radio frequency components (front radar) complies:

- For USA



FCC ID

: 2A30Z-MRR30

This device complies with Part 15 of the FCC Rules. Operation is subject to the following two conditions:

- (1) this device may not cause harmful interference, and
- (2) this device must accept any interference received, including interference that may cause undesired operation.

#### CAUTION TO USERS

Changes or modifications not expressly approved by the party responsible for compliance could void the user's authority to operate the equipment.

- For Canada

Model: MRR-30  
IC: 27992-MRR30

This device complies with Industry Canada licence-exempt RSS standard(s). Operation is subject to the following two conditions: (1) this device may not cause interference, and (2) this device must accept any interference, including interference that may cause undesired operation of the device.

Le présent appareil est conforme aux CNR d'Industrie Canada applicables aux appareils radio exempts de licence. L'exploitation est autorisée

aux deux conditions suivantes:

- (1) l'appareil ne doit pas produire de brouillage, et
- (2) l'utilisateur de l'appareil doit accepter tout brouillage radioélectrique subi, même si le brouillage est susceptible d'en compromettre le fonctionnement.

## Front Corner Radar (if equipped)/Rear Corner Radar

The radio frequency components (Front corner radar/Rear corner radar) complies:

- For USA



FCC ID : LTQ2H5TR

This device complies with Part 15 of the FCC Rules. Operation is subject to the following two conditions:

- (1) this device may not cause harmful interference, and
- (2) this device must accept any interference received, including interference that may cause undesired operation.

#### CAUTION TO USERS

Changes or modifications not expressly approved by the party responsible for compliance could void the user's authority to operate the equipment.



FCC ID : LTQH5TR

This device complies with Part 15 of the FCC Rules. Operation is subject to the following two conditions:

- (1) this device may not cause harmful interference, and
- (2) this device must accept any interference received, including interference that may cause undesired operation.

#### CAUTION TO USERS

Changes or modifications not expressly approved by the party responsible for compliance could void the user's authority to operate the equipment.

- For Canada

Model: 2H5TR  
IC: 3659A-2H5TR

This device complies with Industry Canada licence-exempt RSS standard(s). Operation is subject to the following two conditions:  
(1) this device may not cause interference, and  
(2) this device must accept any interference, including interference that may cause undesired operation of the device.

Le présent appareil est conforme aux CNR d'Industrie Canada applicables aux appareils radio exempts de licence. L'exploitation est autorisée

aux deux conditions suivantes:

- (1) l'appareil ne doit pas produire de brouillage, et
- (2) l'utilisateur de l'appareil doit accepter tout brouillage radioélectrique subi, même si le brouillage est susceptible d'en compromettre le fonctionnement.

Model: H5TR  
IC: 3659A-H5TR

This device complies with Industry Canada licence-exempt RSS standard(s). Operation is subject to the following two conditions:  
(1) this device may not cause interference, and  
(2) this device must accept any interference, including interference that may cause undesired operation of the device.

Le présent appareil est conforme aux CNR d'Industrie Canada applicables aux appareils radio exempts de licence. L'exploitation est autorisée

aux deux conditions suivantes:

- (1) l'appareil ne doit pas produire de brouillage, et
- (2) l'utilisateur de l'appareil doit accepter tout brouillage radioélectrique subi, même si le brouillage est susceptible d'en compromettre le fonctionnement.

# 8. Emergency Situations

Hazard Warning Flasher .....	8-2
In Case of an Emergency While Driving.....	8-2
If the Vehicle Stalls While Driving .....	8-2
If the Vehicle Stalls at A Crossroad or Crossing.....	8-2
If You Have a Flat Tire While Driving .....	8-3
If the Vehicle Will Not Start.....	8-3
Confirm the EV Battery is not Low on the Charge Gauge.....	8-3
Jump Starting (12 V battery) .....	8-4
Tire Pressure Monitoring System (TPMS) .....	8-7
Check Tire Pressure .....	8-7
Tire Pressure Monitoring System.....	8-8
Low Tire Pressure Warning Light .....	8-9
Low Tire Pressure Position and Tire Pressure Telltale.....	8-9
Changing a Tire with TPMS .....	8-10
If You Have a Flat Tire (with Tire Mobility Kit) .....	8-12
Introduction.....	8-12
Notes on the Safe Use of the Tire Mobility Kit .....	8-12
Components of the Tire Mobility Kit .....	8-13
Using the Tire Mobility Kit When a Tire is Flat .....	8-14
How to Adjust Tire Pressure .....	8-17
Towing.....	8-18
Towing Service.....	8-18
Removable Towing Hook .....	8-19

## Hazard Warning Flasher

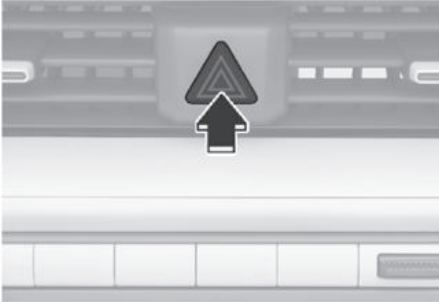

The hazard warning flasher warns other drivers to exercise extreme caution when approaching, overtaking, or passing your vehicle. It should be used whenever making emergency repairs or when stopped near the edge of a roadway.

To turn on or off the hazard warning flasher, press the hazard warning flasher button with the Start/Stop button in any position. The hazard warning flasher button is located in the center fascia panel. All turn signal lights flash simultaneously.

- The hazard warning flasher operates whether your vehicle is running or not.
- The turn signals do not work when the hazard flasher is on.

## In Case of an Emergency While Driving

### If the Vehicle Stalls While Driving

- Reduce the vehicle speed gradually, keeping a straight line. Move cautiously off the road to a safe place.
- Turn on your hazard warning flasher.
- Try to start the vehicle again. If your vehicle does not start, contact an authorized HYUNDAI dealer or seek other qualified assistance.

### If the Vehicle Stalls at A Crossroad or Crossing

If the vehicle stalls at a crossroad or intersection, if safe to do so, shift the gear to N (Neutral) and then push the vehicle to a safe location.

## If You Have a Flat Tire While Driving

If a tire goes flat while you are driving:

- Take your foot off the accelerator pedal and let the vehicle slow down while driving straight ahead. Do not apply the brakes immediately or attempt to pull off the road because this may cause loss of vehicle control resulting in a collision. When the vehicle has slowed to such a speed that it is safe to do so, brake carefully and pull off the road. Drive off the road as far as possible and park on a firm, level ground. If you are on a divided highway, do not park in the median area between the two traffic lanes.
- When the vehicle is stopped, press the hazard warning flasher button, shift the gear to P (Park), apply the parking brake, and press the Start/Stop button to the OFF position.
- Have all passengers get out of the vehicle. Make sure they all get out on the side of the vehicle that is away from traffic.
- When you have a flat tire, refer to the "If You Have a Flat Tire (with Tire Mobility Kit)" section in this chapter.

## If the Vehicle Will Not Start

### Confirm the EV Battery is not Low on the Charge Gauge

- Be sure the gear is in P (Park). The vehicle starts only when the gear is in P (Park).
- Check the 12 V battery connections to be sure they are clean and tight.
- Turn on the interior light. If the light dims or goes out when you operate the starter, the 12 V battery is drained.

#### **NOTICE**

Starting the vehicle by pushing or pulling may cause vehicle damage.

---

## Jump Starting (12 V battery)

Jump starting can be dangerous if done incorrectly. Follow the jump starting procedure in this section to avoid serious injury or damage to your vehicle. If in doubt about how to properly jump start your vehicle, have a service technician or towing service do it for you.

### **WARNING**

To prevent **SERIOUS INJURY** or **DEATH** to you or bystanders, always follow these precautions when working near or handling the battery:



Always read and follow instructions carefully when handling a battery.



Wear eye protection designed to protect the eyes from acid splashes.



Keep all flames, sparks, or smoking materials away from the battery.



Hydrogen gas is always present in battery cells. It is highly combustible, and may explode if ignited.



Keep batteries out of reach of children.



Batteries contain sulfuric acid that is highly corrosive. Do not allow acid to contact your eyes, skin, or clothing. If acid gets into your eyes, flush your eyes with clean water for at least 15 minutes and get immediate medical attention. If acid gets on your skin, thoroughly wash the area. If you feel pain or a burning sensation, get medical attention immediately.

- When lifting a plastic-cased battery, excessive pressure on the case may cause battery acid to leak. Lift with a battery carrier or with your hands on opposite corners.
- Do not attempt to jump start your vehicle if your battery is frozen.
- **NEVER** attempt to recharge the battery when the vehicle's battery cables are connected to the battery.



- The electrical ignition system works with high voltage. NEVER touch these components with the vehicle running or when the Start/Stop button is in the ON position.
- The electrical ignition system works with high voltage. NEVER touch these components Start/Stop button in the ON or START position.
- Do not allow the (+) and (-) jumper cables to touch. It may cause sparks.
- The battery may rupture or explode when you jump start with a low or frozen battery.
- Do not directly connect the (-) to the jump cable. Connect the (-) to the one of the metallic parts located far from the jump cable in the vehicle. The direct (-) connection to the jump cable may cause an explosion.

### ***Jump starting procedure***

#### ***i* Information**

When you jump start your vehicle, use the jumper terminal in the motor compartment.

1. Position the vehicles close enough that the jumper cables will reach. Do not allow the vehicle body parts to contact.
2. Avoid fans or any moving parts in the motor compartment at all times, even when the vehicles are turned off.
3. Turn off all electrical devices such as radios, lights, air conditioning, etc. Put the vehicles in P (Park) and apply the parking brake. Turn both vehicles OFF.
4. Open the hood.
5. Remove the battery cover located inside of the front trunk.
6. Remove the motor compartment fuse box cover.

#### **⚠ CAUTION**

Before jump starting, make sure to correctly identify the positive (+) and negative (-) terminals to avoid reverse polarity connections.

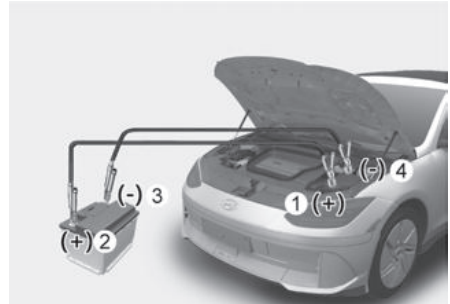

7. Connect the jumper cables in the exact sequence shown in the illustration. First connect one jumper cable to the red, positive (+) jumper terminal of your vehicle (1).
8. Connect the other end of the jumper cable to the red, positive (+) battery/jumper terminal of the assisting vehicle (2).
9. Connect the second jumper cable to the black, negative (-) battery/jumper terminal of the assisting vehicle (3).
10. Connect the other end of the second jumper cable to the black, negative (-) chassis ground of your vehicle (4).

Do not allow the jumper cables to contact anything except the correct battery or jumper terminals or the correct ground. Do not lean over the battery when making connections.

#### **⚠ WARNING**

Do not connect the jumper cable to the negative (-) jumper terminal of the discharged battery. A spark could cause the battery to explode and lead to a personal injury or vehicle damage.

11. Start the assisting vehicle and let it run for a few minutes. Then start your vehicle.
12. Keep your vehicle operating for at least 30 minutes at idle or driving to assure your battery receives enough charge to be able to start on its own after the vehicle is shut off. A completely discharged battery may require as long as 60 minutes runtime to fully recharge it. If the vehicle is run for less, battery may not restart.

If your vehicle does not start after a few attempts, it probably requires service. Have your vehicle inspected by an authorized HYUNDAI dealer.

Disconnect the jumper cables in the exact reverse order you connected them:

1. Disconnect the jumper cable from the chassis ground of your vehicle (4).
2. Disconnect the other end of the jumper cable from battery/chassis ground of the assisting vehicle (3).
3. Disconnect the second jumper cable from the red, positive (+) battery/jumper terminal of the assisting vehicle (2).
4. Disconnect the other end of the jumper cable from the red, positive (+) jumper terminal of your vehicle (1).

### *i* Information



An inappropriately disposed battery can be harmful to the environment and human health. Dispose of the battery according to your local law(s) or regulations.

---

### **NOTICE**

To prevent damage to your vehicle:

- Only use a 12 V power supply (battery or jumper system) to jump start your vehicle.
  - Do not attempt to jump start your vehicle by push-starting.
-

## Tire Pressure Monitoring System (TPMS)

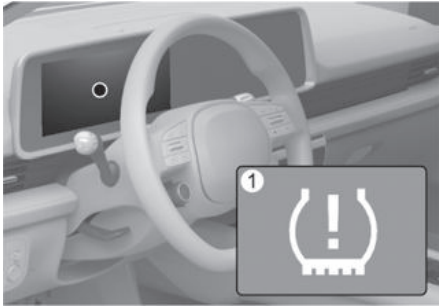

- (1) Low Tire Pressure Telltale/TPMS Malfunction Indicator
- (2) Low Tire Pressure Position Telltale and Tire Pressure Telltale (Shown on the cluster display)

## Check Tire Pressure



- You can check the tire pressure in the Utility view on the instrument cluster. For more information, refer to the “View Modes” section in chapter 4.
- Tire pressure is displayed after a few minutes of driving after initial vehicle start up.
- If tire pressure is not displayed when the vehicle is stopped, **"Drive to display"** message appears. After driving, check the tire pressure.
- The displayed tire pressure values may differ from those measured with a tire pressure gauge.
- You can change the tire pressure unit from the Settings menu in the infotainment system.  
Select **Setup > General > Unit > Tire Air Pressure Unit > psi/kPa/bar**.

### *i* Information

The infotainment system may change after software updates. For more information, refer to the user's manual provided in the infotainment system and the quick reference guide.

## Tire Pressure Monitoring System

### WARNING

Over-inflation or under-inflation can reduce tire life, adversely affect vehicle handling, and lead to sudden tire failure that may cause loss of vehicle control resulting in an accident.

---

Each tire, including the spare (if provided), should be checked monthly when cold and inflated to the inflation pressure recommended by the vehicle manufacturer on the vehicle placard or tire inflation pressure label. (If your vehicle has tires of a different size than the size indicated on the vehicle placard or tire inflation pressure label, you should determine the proper tire inflation pressure for those tires.)

As an added safety feature, your vehicle has been equipped with a tire pressure monitoring system (TPMS) that illuminates a low tire pressure telltale when one or more of your tires is significantly under-inflated. Accordingly, when the low tire pressure telltale illuminates, you should stop and check your tires as soon as possible, and inflate them to the proper pressure. Driving on a significantly under-inflated tire causes the tire to overheat and can lead to tire failure.

Under-inflation also reduces energy efficiency and tire tread life, and may affect the vehicle's handling and stopping ability.

Please note that the TPMS is not a substitute for proper tire maintenance, and it is the driver's responsibility to maintain correct tire pressure, even if under-inflation has not reached the level to trigger illumination of the TPMS low tire pressure telltale.

Your vehicle has also been equipped with a TPMS malfunction indicator to indicate

when the system is not operating properly. The TPMS malfunction indicator is combined with the low tire pressure telltale. When the system detects a malfunction, the telltale will flash for about one minute and then remain continuously illuminated. This sequence will continue upon subsequent vehicle start-ups as long as the malfunction exists.

When the malfunction indicator is illuminated, the system may not be able to detect or signal low tire pressure as intended. TPMS malfunctions may occur for a variety of reasons, including the installation of replacement or alternate tires or wheels on the vehicle that prevent the TPMS from functioning properly.

Always check the TPMS malfunction telltale after replacing one or more tires or wheels on your vehicle to ensure that the replacement or alternate tires and wheels allow the TPMS to continue to function properly.

### NOTICE

If any of the below happens, have the system inspected by an authorized HYUNDAI dealer.

1. The Low Tire Pressure Telltale/TPMS Malfunction Indicator does not illuminate for 3 seconds when the Start/Stop button is pressed to the ON position or when the vehicle is running.
  2. The TPMS Malfunction Indicator remains illuminated after blinking for about 1 minute.
  3. The Low Tire Pressure Position Telltale remains illuminated.
-

## Low Tire Pressure Warning Light



## Low Tire Pressure Position and Tire Pressure Telltale



When the tire pressure monitoring system warning indicators are illuminated and a warning message displayed on the cluster display, one or more of your tires is significantly under-inflated. The Low Tire Pressure Position Telltale will indicate which tire is significantly underinflated by illuminating the corresponding parking light.

If either telltale illuminates, immediately reduce your speed, avoid hard cornering and anticipate increased stopping distances. You should stop and check your tires as soon as possible. Inflate the tires to the proper pressure as indicated on the vehicle's placard or tire inflation pressure label located on the driver's side center pillar outer panel.

If you cannot reach a service station or if the tire cannot hold the newly added air, replace the low pressure tire with the spare tire.

The Low Tire Pressure Telltale will remain on and the TPMS Malfunction Indicator may blink for one minute and then remain illuminated (when the vehicle is driven about 10 minutes at speed above 15.5 mph (25 km/h)) until you have the low pressure tire repaired and replaced on the vehicle.

### CAUTION

In winter or cold weather, the Low Tire Pressure Telltale may be illuminated if the tire pressure was adjusted to the recommended tire inflation pressure in warm weather. It does not mean your TPMS is malfunctioning because the decreased temperature leads to a proportional lowering of tire pressure.

When you drive your vehicle from a warm area to a cold area or from a cold area to a warm area, or the outside temperature is greatly higher or lower, you should check the tire inflation pressure and adjust the tires to the recommended tire inflation pressure.

### WARNING

Low pressure damage

Significantly low tire pressure makes the vehicle unstable and can contribute to loss of vehicle control and increased braking distances.

Continued driving on low pressure tires can cause the tires to overheat and fail.

### TPMS (Tire Pressure Monitoring System) Malfunction Indicator



The TPMS Malfunction Indicator will illuminate after it blinks for about one minute when there is a problem with the Tire Pressure Monitoring System.

Have the system inspected by an authorized HYUNDAI dealer as soon as possible.

#### **NOTICE**

If there is a malfunction with the TPMS, the Low Tire Pressure Position Telltale will not be displayed even though the vehicle has an under-inflated tire.

---

#### **NOTICE**

The TPMS Malfunction Indicator may illuminate after blinking for one minute if the vehicle is near electric power supply cables or radio transmitters such as police stations, government and public offices, broadcasting stations, military installations, airports, transmitting towers, etc.

Additionally, the TPMS Malfunction Indicator may illuminate if snow chains are used or electronic devices such as computers, chargers, remote starters, navigation, etc. This may interfere with normal operation of the TPMS.

---

### Changing a Tire with TPMS

If you have a flat tire, the Low Tire Pressure and Position telltales will come on. Have the flat tire repaired by an authorized HYUNDAI dealer as soon as possible or replace the flat tire with the spare tire.

#### **NOTICE**

It is recommended that you do not use a puncture-repairing agent not approved by an authorized HYUNDAI dealer or the equivalent specified for your vehicle to repair and/or inflate a low pressure tire. Tire sealant not approved by an authorized HYUNDAI dealer or the equivalent specified for your vehicle may damage the tire pressure sensor.

---

The spare tire (if equipped) does not come with a tire pressure monitoring sensor. When the low pressure tire or the flat tire is replaced with the spare tire, the Low Tire Pressure Telltale will remain on. Also, the TPMS Malfunction Indicator will illuminate after blinking for one minute if the vehicle is driven at speed above 15.5 mph (25 km/h) for about 10 minutes.

Once the original wheel equipped with a tire pressure monitoring sensor is reinflated to the recommended pressure and reinstalled on the vehicle, the Low Tire Pressure Telltale and TPMS Malfunction Indicator will go off within a few minutes of driving.

If the indicators do not extinguish after a few minutes, consult an authorized HYUNDAI dealer.

Each wheel is equipped with a tire pressure sensor mounted inside the tire behind the valve stem (except for the spare tire). You must use TPMS specific wheels. It is recommended that you always have your tires serviced by an authorized HYUNDAI dealer.

You may not be able to identify a tire with low pressure by simply looking at it.

Always use a good quality tire pressure gauge to measure. Please note that a tire that is hot (from being driven) will have a higher pressure measurement than a tire that is cold.

A cold tire means the vehicle has been sitting for 3 hours and driven for less than 1 mi. (1.6 km) in that 3 hour period.

Allow the tire to cool before measuring the inflation pressure. Always be sure the tire is cold before inflating to the recommended pressure.

### WARNING

- The TPMS cannot alert you to severe and sudden tire damage caused by external factors such as nails or road debris.
- If you feel any vehicle instability, immediately take your foot off the accelerator pedal, apply the brakes gradually with light force, and slowly move to a safe position off the road.

### WARNING

Tampering with, modifying, or disabling the Tire Pressure Monitoring System (TPMS) components may interfere with the system's ability to warn the driver of low tire pressure conditions and/or TPMS malfunctions and may void the warranty.

### WARNING

This device complies with Part 15 of the FCC rules.

Operation is subject to the following three conditions:

1. This device may not cause harmful interference.
2. This device must accept any interference received, including interference that may cause undesired operation of the device.
3. Changes or modifications not expressly approved by the party responsible for compliance could void the user's authority to operate the device.

## If You Have a Flat Tire (with Tire Mobility Kit)

 If equipped



For safe operation, carefully read and follow the instructions in this manual before use.

1. Compressor
2. Sealant bottle

The tire mobility kit is a temporary fix to the tire, have the tire inspected by an authorized HYUNDAI dealer or the sealant provided with the Tire Mobility Kit must be used for only one flat tire.

### CAUTION

When two or more tires are flat, do not use the tire mobility kit because the sealant provided with the Tire Mobility Kit must be used for only one flat tire.

### WARNING

Do not use the Tire Mobility Kit to repair punctures in the tire walls. This can result in an accident due to tire failure.

### WARNING

Have your tire repaired as soon as possible. The tire may lose air pressure at any time after inflating with the Tire Mobility Kit.

## Introduction

With the Tire Mobility Kit you can stay mobile even after experiencing a tire puncture.

The compressor and sealing compound system effectively and comfortably seals most punctures in a passenger car tire caused by nails or similar objects and reinflates the tire.

After you ensure that the tire is properly sealed you can drive cautiously on the tire (distance up to 120 mi. (200 km)) at a max. speed of 50 mph (80 km/h) in order to reach a service station or tire dealer for the tire replacement.

It is possible that some tires, especially with larger punctures or damage to the sidewall, cannot be sealed completely.

Air pressure loss in the tire may adversely affect tire performance.

For this reason, you should avoid abrupt steering or other driving maneuvers, especially if the vehicle is heavily loaded or if a trailer is in use.

The Tire Mobility Kit is not designed or intended as a permanent tire repair method and is to be used for one tire only.

This instruction shows you step by step how to temporarily seal the puncture simply and reliably.

Read the section “Notes on the safe use of the Tire Mobility Kit”.

## Notes on the Safe Use of the Tire Mobility Kit

- Park your vehicle at the side of the road so that you can work with the Tire Mobility Kit away from moving traffic.
- To be sure your vehicle will not move, even when you're on fairly level ground, always apply your parking brake.
- Only use the Tire Mobility Kit for sealing/inflation passenger car tires. Only punctured areas located within



the tread region of the tire can be sealed using the tire mobility kit.

- Do not use on motorcycles, bicycles or any other type of tires.
- When the tire and wheel are damaged, do not use Tire Mobility Kit for your safety.
- Use of the Tire Mobility Kit may not be effective for tire damage larger than about 0.16 in. (4 mm).
- If the tire cannot be made roadworthy with the Tire Mobility Kit, contact an authorized HYUNDAI dealer.
- Do not use the Tire Mobility Kit if a tire is severely damaged by driving run flat or with insufficient air pressure. Only punctured areas located within the tread region of the tire can be sealed using the Tire Mobility Kit.
- Do not remove any foreign objects such as nails or screws that have penetrated the tire.
- Provided the vehicle is outdoors, leave the vehicle running. Otherwise operating the compressor may eventually drain the car battery.
- Never leave the Tire Mobility Kit unattended while it is being used.
- Do not leave the compressor running for more than 10 minutes at a time or it may overheat.
- Do not use the Tire Mobility Kit if the ambient temperature is below -22 °F (-30 °C).
- In case of skin contact with the sealant, wash the area thoroughly with plenty of water. If the irritation persists, seek medical attention.
- In case of eye contact with the sealant, flush your eyes for at least 15 minutes. If the irritation persists, seek medical attention.
- In case of swallowing the sealant, rinse the mouth and drink plenty of water. However, never give anything to an

unconscious person and seek medical attention immediately.

- Long time exposure to the sealant may cause damage to bodily tissue such as kidney, etc.

## Components of the Tire Mobility Kit

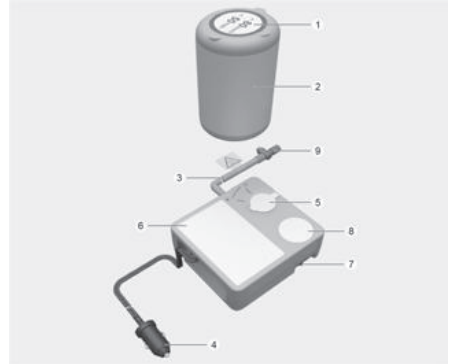

1. Speed-restriction label
2. Sealant bottle and label with speed restriction
3. Filling hose
4. Connectors and cable for the power outlet direct connection
5. Holder for the sealant bottle
6. Compressor
7. ON/OFF switch
8. Pressure gauge for displaying the tire inflation pressure
9. Button for reducing the tire inflation pressure

Connectors, cable and connection hose are stored in the compressor housing.

Strictly follow the specified sequence, otherwise the sealant may escape under high pressure.

### WARNING

Do not use the tire sealant after the sealant has expired (the expiration date is pasted on the sealant container). This can increase the risk of tire failure.

### WARNING

Sealant

- Keep out of reach of children.
- Avoid contact with eyes.
- Do not swallow.

## Using the Tire Mobility Kit When a Tire is Flat

### CAUTION



Detach the speed restriction label (1) from the sealant bottle (2), and place it in a highly visible place inside the vehicle such as on the steering wheel to remind the driver not to drive too fast.

### CAUTION

If only the tire pressure needs to be adjusted, refer to the “How to Adjust Tire Pressure” in this chapter.

Before using the Tire Mobility Kit, be fully aware of the explanation on the sealant.



1. Shake the sealant bottle (2).



2. Remove the sealant bottle (2) cap and sealant bottle holder (5) cap and screw the bottle onto the sealant bottle holder.
3. Make sure the compressor valve on the filling hose is locked.
4. Unscrew the valve cap and screw the filling hose (3) onto the tire valve.

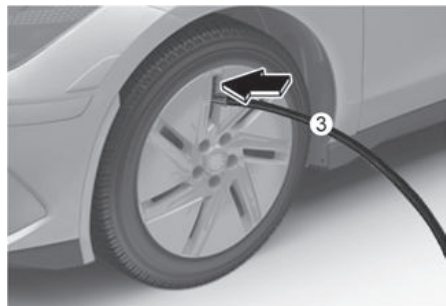

**⚠ CAUTION**

Securely install the sealant filling hose to the valve. If not, sealant may flow backward, possibly clogging the filling hose.

5. Make sure the compressor is turned off and plug the compressor power cord (4) into the vehicle power outlet.



6. With the vehicle on (**READY** indicator on), switch on the compressor and let it run for about 5-7 minutes to on sealant up on proper pressure (For more information, refer to the "Tires and Wheels" section in chapter 2).  
Be careful not to overinflate the tire and stay away from the tire when filling it.

**⚠ CAUTION**

Tire pressure

Do not attempt to drive your vehicle if the tire pressure is below 29 psi (200 kPa). This could result in an accident due to sudden tire failure.

7. Switch off the compressor.  
8. Detach the hoses from the sealant bottle connector and from the tire valve.  
9. Return the Tire Mobility Kit to its storage location in the vehicle.

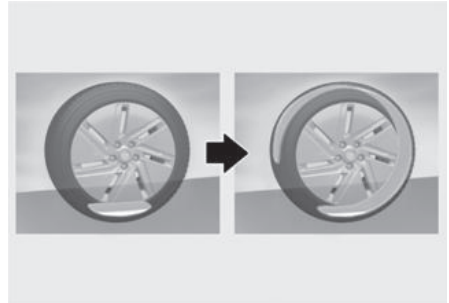

10. Immediately drive about 4-6 mi. (7-10 km or, about 10 minutes) to evenly distribute the sealant in the tire.

Do not exceed a speed of 50 mph (80 km/h). If possible, do not fall below a speed of 12 mph (20 km/h).

While driving, if you experience any unusual vibration, ride disturbance or noise, reduce your speed and drive with caution until you can safely pull off of the side of the road.

Call for road side service or towing.

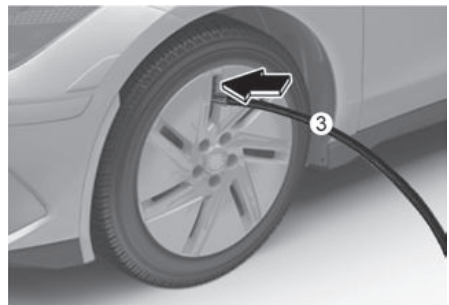

11. After driving about 4-6 mi. (7-10 km or about 10 minutes), stop at a safety location.  
12. Connect the filling hose (3) of the compressor directly to the tire valve.

13. Plug the compressor power cord into the vehicle power outlet.
14. Adjust the tire inflation pressure to the recommended tire inflation.

With the vehicle on (**READY** indicator on) proceed as follows.

- To increase the inflation pressure: Switch on the compressor. To check the current tire inflation pressure setting, briefly switch off the compressor.
- To reduce the tire inflation pressure: Press the button (9) on the compressor.

### **i** Information

The pressure gauge may show higher than actual reading when the compressor is running. To get an accurate tire reading, the compressor needs to be turned off.

---

### **!** CAUTION

If the tire inflation pressure is not maintained, drive the vehicle a second time, refer to step 9.

Then repeat steps 10 to 13.

Use of the TMK may be ineffectual for tire damage larger than about 0.16 in. (4 mm).

Contact an authorized HYUNDAI dealer if the tire cannot be made roadworthy with the Tire Mobility Kit.

---

### **!** WARNING

The tire inflation pressure must be at least 32 psi (220 kPa). If it is not, do not continue driving.

Call for road side service or towing.

---

### **!** CAUTION

Tire pressure sensor (if equipped with TPMS)

The sealant on the tire pressure sensor and wheel should be removed when you replace the tire with a new one and inspect the tire pressure sensors. Have this done at an authorized HYUNDAI dealer.

---

### **i** Information

When reinstalling the repaired or replaced tire and wheel on the vehicle, tighten the wheel lug nut to 79-94 lbf-ft (11-13 kgf-m).

---

## How to Adjust Tire Pressure

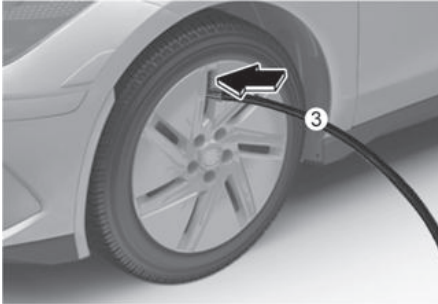

1. Park your vehicle in a safe location.
2. Connect the filling hose (3) of the compressor directly to the tire valve.
3. Plug the compressor power cord into the vehicle power outlet.
4. Adjust the tire inflation pressure to the recommended tire inflation.

With the vehicle on (**READY** indicator on), proceed as follows.

- To increase the inflation pressure: Switch on the compressor. To check the current tire inflation pressure setting, briefly switch off the compressor.
- To reduce the tire inflation pressure: Press the button (9) on the compressor.

### *i* Information

- The pressure gauge may show higher than actual reading when the compressor is running. To get an accurate tire reading, the compressor needs to be turned off.
- When reinstalling the repaired or replaced tire and wheel on the vehicle, tighten the wheel lug nut to 79-94 lbf·ft (11-13 kgf·m).

### CAUTION

Do not use the sealant when the tire pressure only needs to be adjusted.

### WARNING

The tire inflation pressure must be inflated to the proper pressure (For more information, refer to the “Tires and Wheels” section in chapter 2). If it is not, do not continue driving.

Call for road side service or towing.

## Towing

### Towing Service

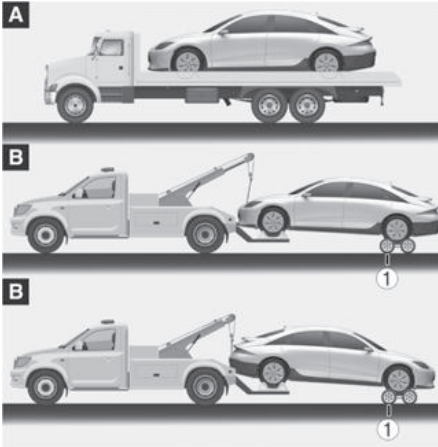

(1) Dollies

If emergency towing is necessary, have it done by an authorized HYUNDAI dealer or a commercial tow-truck service.

Proper lifting and towing procedures are necessary to prevent damage to the vehicle. The use of wheel dollies or flatbed is recommended.

**2WD vehicle** is acceptable to tow the vehicle with the front wheels on the ground (without dollies) and the rear wheels off the ground.

If any of the loaded wheels or suspension components are damaged or the vehicle is being towed with the rear wheels on the ground, use a towing dolly under the rear wheels.

When being towed by a commercial tow truck and wheel dollies are not used, the rear of the vehicle should always be lifted, not the front.

### ⚠ CAUTION



Do not tow the vehicle with the rear wheels on the ground as this may cause damage to the vehicle.

**AWD vehicle** must be towed with a wheel lift and dollies or flatbed equipment with all the wheels off the ground.

### **Precautions when moving a short distance before towing a vehicle**

Move short distances within 33 ft. (10 m) at a speed of 3 mph (5 km/h) or less only when loading on a tow truck or if the vehicle needs to be repositioned.

At this time, the gear must be in the N (Neutral) position and the parking brake must be released. If it is impossible to operate the gear and parking brake, move the vehicle with the rear wheel lifted.

### NOTICE

Do not lift the vehicle by the tow fitting or body and chassis parts. Otherwise the vehicle may be damaged.

### ⚠ CAUTION

Do not tow with sling-type equipment. Use wheel lift or flatbed equipment.



## Removable Towing Hook

1. Open the trunk, and remove the towing hook from the tool case.
2. Remove the hole cover.

Front



3. Push the lower part of the bumper hole cover.

Rear

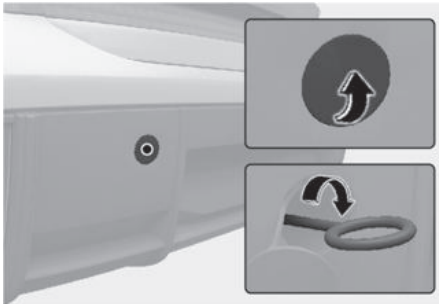

- Push the upper part of the bumper hole cover.
  - Pull the lower part of the bumper hole cover.
4. Install the towing hook by turning it clockwise into the hole until it is fully secured.
  5. Remove the towing hook and install the cover after use.

### NOTICE

Failure to properly tighten the towing hook may result in vehicle damage and deformation of related parts.

### CAUTION

Make sure the towing hook is tightened properly. If not, during towing the towing hook may be thrown off the vehicle resulting in serious injury or accident.





# 9. Maintenance

Motor Compartment .....	9-4
Maintenance Services .....	9-5
Owner's Responsibility .....	9-5
Owner Maintenance Precautions .....	9-5
Owner Maintenance .....	9-6
Owner Maintenance Schedule.....	9-6
Scheduled Maintenance Services .....	9-8
Normal Maintenance Schedule .....	9-9
Normal Maintenance Schedule .....	9-10
Maintenance Under Severe Usage and Low Mileage Conditions .....	9-11
Explanation of Scheduled Maintenance Items.....	9-12
Cooling System .....	9-12
Coolant .....	9-12
Gear Fluid .....	9-12
Brake Hoses and Lines.....	9-12
Brake Fluid.....	9-12
Brake Discs, Pads, Calipers and Rotors.....	9-12
Suspension Mounting Bolts .....	9-12
Steering Gear Box, Linkage & Boots/Lower Arm Ball Joint .....	9-12
Drive Shafts and Boots .....	9-12
Air Conditioning Refrigerant .....	9-12
Coolant .....	9-13
Changing Coolant .....	9-14
Brake Fluid .....	9-14
Checking the Brake Fluid Level.....	9-14
Gear Fluid .....	9-15
Washer Fluid .....	9-16
Checking the Washer Fluid Level .....	9-16
Cabin Air Filter .....	9-16
Filter Inspection .....	9-16
Filter Replacement.....	9-16
Wiper Blades.....	9-17
Blade Inspection .....	9-17
Blade Replacement.....	9-17

Battery (12 V) .....	9-19
For Best Battery Service .....	9-21
Battery Capacity Label.....	9-21
Battery Recharging .....	9-21
Reset Items .....	9-22
Tires and Wheels .....	9-23
Tire Care .....	9-23
Recommended Cold Tire Inflation Pressures.....	9-23
Check Tire Inflation Pressure.....	9-24
Tire Rotation .....	9-25
Wheel Alignment and Tire Balance .....	9-25
Tire Replacement .....	9-26
Wheel Replacement.....	9-26
Tire Traction.....	9-27
Tire Maintenance.....	9-27
Tire Sidewall Labeling .....	9-27
Tire Terminology and Definitions .....	9-30
All Season Tires.....	9-33
Summer Tires.....	9-33
Snow Tires.....	9-33
Radial-Ply Tires .....	9-33
Low Aspect Ratio Tires.....	9-34
Fuses .....	9-35
Instrument Panel Fuse Replacement.....	9-36
Motor Compartment Panel Fuse Replacement .....	9-36
Fuse/Relay Panel Description .....	9-38

# 9. Maintenance

Light Bulbs .....	9-46
Headlight, Parking Light, Turn Signal Light, Daytime Running Light (DRL) Replacement .....	9-47
Side Repeater Light Replacement .....	9-47
Rear Combination Light Replacement .....	9-48
High Mounted Stop Light Replacement.....	9-48
License Plate Light Replacement .....	9-48
Front Trunk Light Replacement .....	9-49
Interior Light Replacement .....	9-49
Appearance Care .....	9-50
Exterior Care.....	9-50
Interior Care .....	9-55
California Perchlorate Notice .....	9-57

## Motor Compartment

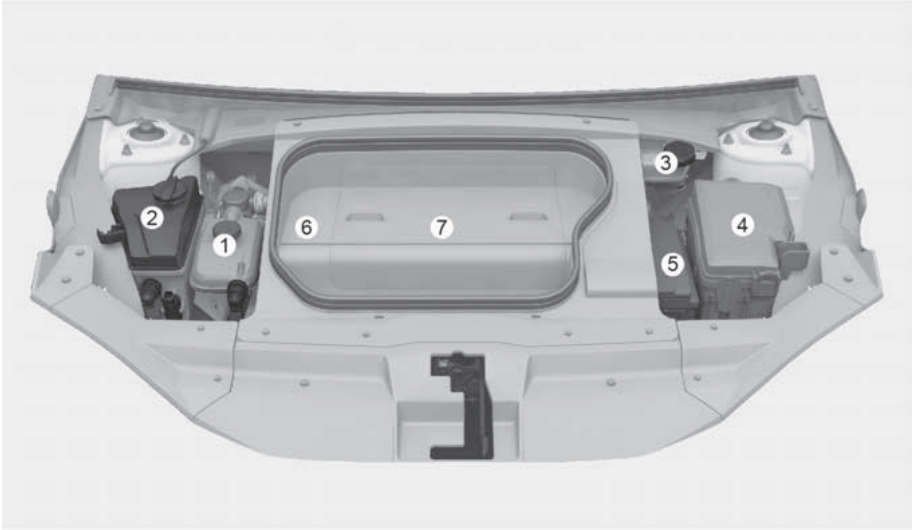

**The actual motor compartment in the vehicle may differ from the illustration.**

- (1) Coolant reservoir
- (2) Windshield washer fluid reservoir
- (3) Brake fluid reservoir
- (4) Fuse box
- (5) Battery (12 V)
- (6) Front trunk
- (7) Cabin air filter

## Maintenance Services

You should exercise the utmost care to prevent damage to your vehicle and injury to yourself whenever performing any maintenance or inspection procedures.

Have your vehicle maintained and repaired by an authorized HYUNDAI dealer. An authorized HYUNDAI dealer meets HYUNDAI's high service quality standards and receives technical support from HYUNDAI in order to provide you with a high level of service satisfaction.

## Owner's Responsibility

Maintenance service and record retention are the owner's responsibility.

You should retain documents that show proper maintenance has been performed on your vehicle in accordance with the scheduled maintenance service charts shown on the following pages. You need this information to establish your compliance with the servicing and maintenance requirements of your vehicle warranties.

Detailed warranty information is provided in your Owner's Handbook & Warranty Information booklet.

Repairs and adjustments required as a result of improper maintenance or a lack of required maintenance are not covered.

## Owner Maintenance Precautions

Inadequate, incomplete or insufficient servicing may result in operational problems with your vehicle that could lead to vehicle damage, an accident, or personal injury. This chapter provides instructions only for the maintenance items that are easy to perform.

Your vehicle should not be modified in any way. Such modifications may adversely affect the performance, safety or durability of your vehicle and may, in addition, violate conditions of the limited warranties covering the vehicle.

Certain modifications may also be in violation of regulations established by the U.S. Department of Transportation and other federal or state agencies.

### NOTICE

Improper owner maintenance during the warranty period may affect warranty coverage. For more information, read the separate Owner's Handbook & Warranty Information booklet provided with the vehicle. If you're unsure about any service or maintenance procedure, have it done by an authorized HYUNDAI dealer.

## Owner Maintenance

### WARNING

Performing maintenance work on a vehicle can be dangerous. If you lack sufficient knowledge and experience or the proper tools and equipment to do the work, we recommend that it is done by an authorized HYUNDAI dealer. ALWAYS follow these precautions for performing maintenance work:

- Park your vehicle on level ground. Shift the vehicle to P (Park), apply the parking brake, and press the Start/Stop button to the OFF position.
  - Block the tires (front and back) to prevent the vehicle from moving.  
Remove loose clothing or jewelry that can become entangled in moving parts.
  - Keep flames, sparks, or smoking materials away from the battery and motor related parts.
- 

### WARNING

Make sure to turn the Start/Stop button to the OFF position to shut down the vehicle before performing maintenance work on the vehicle.

---

The following lists are vehicle checks and inspections that should be performed by the owner or an authorized HYUNDAI dealer at the frequencies indicated to help ensure safe, dependable operation of your vehicle.

Any adverse conditions should be brought to the attention of your dealer as soon as possible.

These Owner Maintenance vehicle checks are generally not covered by warranties and you may be charged for labor, parts and lubricants used.

The electric control system in the vehicle may cause malfunction or other negative impact on the artificial heart and the artificial internal organs. Be sure to inquire the impact of the electric control system on the artificial organs from the medical product corporation.

## Owner Maintenance Schedule

### ***When you stop for charging:***

- Check the coolant level in the coolant reservoir.
- Check the windshield washer fluid level.
- Check for low or under-inflated tires.

### WARNING

Be careful when checking your coolant level if the motor compartment is hot. This may result in coolant being blown out of the opening and cause serious burns and other injuries.

---

***While operating your vehicle:***

- Check for vibrations in the steering wheel. Notice if there is any increased steering effort or looseness in the steering wheel, or change in its straight-ahead position.
- Notice if your vehicle constantly turns slightly or “pulls” to one side when traveling on smooth, level road.
- When stopping, listen and check for unusual sounds, pulling to one side, increased brake pedal travel or “hard-to-push” brake pedal.
- If any slipping or changes in the operation of your gear shift occurs, check the shift gear fluid level.
- Check the shift gear P (Park) function.
- Check the parking brake.
- Check for fluid leaks under your vehicle (water dripping from the air conditioning system during or after use is normal).

***At least monthly:***

- Check coolant level in the coolant reservoir.
- Check the operation of all exterior lights, including the stoplights, turn signals and hazard warning flashers.
- Check the inflation pressures of all tires including the spare for tires that are worn, show uneven wear, or are damaged.
- Check for loose wheel lug nuts.

***At least twice a year: (for example, every Spring and Autumn)***

- Check radiator, heater and air conditioning hoses for leaks or damage.
- Check windshield washer spray and wiper operation. Clean wiper blades with a clean cloth dampened with washer fluid.
- Check headlight alignment.
- Check the seat belts for wear and function.

***At least once a year:***

- Clean body and door drain holes.
- Lubricate door hinges and hood hinges.
- Lubricate door and hood locks and latches.
- Lubricate door rubber weather strips.
- Check the air conditioning system.
- Inspect and lubricate shift gear linkage and controls.
- Clean the battery (12 V) and terminals.
- Check the brake fluid level.

## Scheduled Maintenance Services

Follow Normal Maintenance Schedule if the vehicle is usually operated where none of the following conditions apply. If any of the following conditions apply, you must follow the Maintenance Under Severe Usage Conditions.

- Repeated driving short distance of less than 5 mi. (8 km) in normal temperature or less than 10 mi. (16 km) in freezing temperature
- Driving on rough, dusty, muddy, unpaved, graveled or salt-spread roads
- Driving in areas using salt or other corrosive materials or in very cold weather
- Driving in heavy dust condition
- Driving in heavy traffic area with the ambient temperature higher than 90 °F (32 °C) while consuming more than 50% of electric energy.
- Driving on uphill, downhill, or mountain roads repeatedly
- Towing a trailer or using a camper, or driving with loads on the roof
- Driving as a patrol car, taxi, other commercial use or vehicle towing
- Frequently driving under high speed or rapid acceleration/deceleration
- Frequently driving in stop-and-go conditions

If your vehicle is operated under the above conditions, you should inspect, replace or refill more frequently than the following Normal Maintenance Schedule. After the periods or distance shown in the chart, continue to follow the prescribed maintenance intervals.



## Normal Maintenance Schedule

The following maintenance services must be performed to ensure good vehicle performance.

Keep receipts for all vehicle services to protect your warranty. Where both mileage and time are shown, the frequency of service is determined by whichever occurs first.

MAINTENANCE INTERVALS	Months	12	24	36	48	60	72	84	96	108	120	132	144	156	
	Miles× 1,000	8	16	24	32	40	48	56	64	72	80	88	96	104	
	Km× 1,000	13	26	39	52	65	78	91	104	117	130	143	156	169	
MAINTENANCE ITEM															
Cooling system															
12 V auxiliary battery condition															
Brake lines, hoses, and connections															
Disc brakes and pads	I	I	I	I	I	I	I	I	I	I	I	I	I	I	I
Brake pedal															
Steering gear rack, linkage, and boots															
Air conditioning compressor, air conditioner refrigerant and performance															

I: Inspect and if necessary, adjust, correct, clean or replace.

R: Replace or change.

## Normal Maintenance Schedule

MAINTENANCE INTERVALS	Months	12	24	36	48	60	72	84	96	108	120	132	144	156	
	Miles×1,000	8	16	24	32	40	48	56	64	72	80	88	96	104	
	Km×1,000	13	26	39	52	65	78	91	104	117	130	143	156	169	
MAINTENANCE ITEM															
Drive shafts and boots			I			I			I			I			I
Replace Climate Control Air Filter (For Evaporator and Blower Unit)		I	R	I	R	I	R	I	R	I	R	I	R	I	
Gear fluid					I				I				I		
Rotate Tires (Includes Tire Pressure and Tread Wear Inspection)	Rotate every 8,000 mi. (13,000 km) or 12 months														
Coolant *1	At first, replace 120,000 mi. (200,000 km) or 120 months. After that, replace every 24,000 mi. (40,000 km) or 24 month.														
Brake fluid	Inspect every 7,500 mi. (12,000 km) or 12 months, Replace every 60,000 mi. (96,000 km) or 48 months														

\*1 Consult an authorized HYUNDAI dealer, when replacing or adding coolant.

I: Inspect and if necessary, adjust, correct, clean or replace.

R: Replace or change.

## Maintenance Under Severe Usage and Low Mileage Conditions

The following items must be serviced more frequently on cars mainly used under severe driving conditions.

Refer to the chart below for the appropriate maintenance intervals.

R: Replace

I: Inspect and if necessary, adjust, correct, clean or replace

Maintenance item	Maintenance operation	Maintenance intervals	Driving condition
Gear fluid	R	Replace every 80,000 mi.(120,000 km)	B, D, G, H
Steering gear rack, linkage and boots	I	Inspect more frequently depending on the condition	B, C, D, E, F
Front suspension ball joints	I	Inspect more frequently depending on the condition	B, C, D, E, F
Disc brakes and pads, calipers and rotors	I	Inspect more frequently depending on the condition	B, C, D, E, F, G, H, I, J
Drive shaft and boots	I	Inspect more frequently depending on the condition	B, C, D, E, F, G, H, I
Cabin air filter	R	Replace more frequently depending on the condition	B, D, F

### Severe driving conditions

- A. Repeatedly driving short distance of less than 5 mi. (8 km) in normal temperature or less than 10 mi. (16 km) in freezing temperature
- B. Driving on rough, dusty, muddy, unpaved, graveled or salt spread roads
- C. Driving in areas using salt or other corrosive materials or in very cold weather
- D. Driving in heavy dust condition
- E. Driving in heavy traffic area with the ambient temperature higher than 90 °F (32 °C) while consuming more than 50 % of electric energy.
- F. Driving on uphill, downhill, or mountain roads repeatedly
- G. Towing a trailer or using a camper, or driving with loads on the roof
- H. Driving as a patrol car, taxi, other commercial use or vehicle towing
- I. Frequently driving under high speed or rapid acceleration/deceleration
- J. Frequently driving in stop-and-go conditions

## Explanation of Scheduled Maintenance Items

### Cooling System

Check cooling system components, such as radiator, coolant reservoir, hoses and connections for leakage and damage. Replace any damaged parts.

### Coolant

The coolant should be changed at the intervals specified in the maintenance schedule.

### Gear Fluid

The gear fluid should be inspected and replaced according to the intervals specified in the maintenance schedule.

### Brake Hoses and Lines

Visually check for proper installation, chafing, cracks, deterioration and any leakage. Replace any deteriorated or damaged parts immediately.

### Brake Fluid

Check the brake fluid level in the brake fluid reservoir. The level should be between the MIN and the MAX marks on the side of the reservoir. Use only hydraulic brake fluid conforming to DOT 4 specification.

### Brake Discs, Pads, Calipers and Rotors

Check the pads, the discs, and the rotors for any excessive wear-out. Inspect calipers for any fluid leakage.

### Suspension Mounting Bolts

Check the suspension connections for looseness or damage. Retighten to the specified torque.

### Steering Gear Box, Linkage & Boots/Lower Arm Ball Joint

With the vehicle stopped and the vehicle off, check for excessive free-play in the steering wheel. Check the linkage for bends or damage. Check the dust boots and ball joints for deterioration, cracks, or damage.

Replace any damaged parts.

### Drive Shafts and Boots

Check the drive shafts, boots and clamps for cracks, deterioration, or damage. Replace any damaged parts and, if necessary, repack the grease.

### Air Conditioning Refrigerant

Check the air conditioning lines and connections for leakage and damage.

## Coolant



Check the condition and connections of all cooling system hoses and heater hoses. Replace any swollen or deteriorated hoses.

The coolant level should be filled between the MAX or F and the MIN or L marks on the side of the coolant reservoir when the parts in the motor compartment is cool.

If the coolant level is low, have the vehicle inspected by an authorized HYUNDAI dealer.

### WARNING



Keep hands, clothing, and tools away from the rotating fan blades of the cooling fan. The cooling fan may continue to operate even though the vehicle is turned off and can cause serious injury.

The electric motor for the cooling fan is controlled by vehicle coolant temperature, refrigerant pressure and vehicle speed. As the vehicle coolant temperature decreases, the electric motor will automatically shut off.

### Recommended coolant

- When adding coolant, use only deionized water, distilled water, or soft water for your vehicle and never mix hard water in the coolant filled at the factory.
- An incorrect coolant mixture may result in severe malfunction or motor damage.
- Do not use alcohol or methanol coolant or mix them with the specified coolant.
- Do not use a solution that contains more than 60% antifreeze or less than 35% antifreeze, which could reduce the effectiveness of the solution.

For mixing percentage, refer to the following table:

Ambient Temperature	Mixture Percentage (volume)	
	Antifreeze	Water
5 °F (-15 °C)	35	65
-13 °F (-25 °C)	40	60
-31 °F (-35 °C)	50	50
-49 °F (-45 °C)	60	40

### *i* Information

If in doubt about the mix ratio, a 50 % water and 50 % antifreeze mix is the easiest to mix together because it is the same quantity for each.

## Changing Coolant

Have the coolant changed by an authorized HYUNDAI dealer according to the Maintenance Schedule.

### NOTICE

To prevent damage to motor parts, put a thick towel around the coolant cap before refilling the coolant to prevent the coolant from overflowing into motor parts.

---

## Brake Fluid

### Checking the Brake Fluid Level

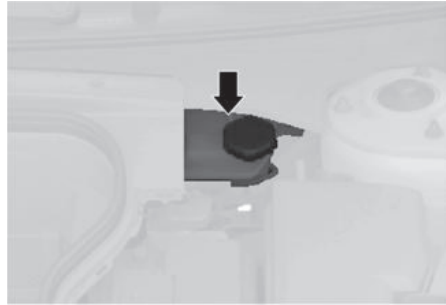

Check the fluid level in the reservoir periodically. The fluid level should be between MAX and MIN marks on the side of the reservoir.

Before removing the reservoir cap and adding brake fluid, clean the area around the reservoir cap thoroughly to prevent brake fluid contamination.

If the level is low, add the specified brake fluid to the MAX level. If the fluid level is excessively low or frequent additions are required have the brake system inspected by an authorized HYUNDAI dealer.

### WARNING

If brake fluid comes in contact with your eyes, flush your eyes with clean water for at least 15 minutes and get immediate medical attention.

---

**NOTICE**

- Do not allow brake fluid to contact the vehicle's body paint, because paint damage may occur.
  - Never use brake fluid that has been exposed to open air for an extended time and dispose of it properly.
  - Do not use the wrong type of brake fluid. A few drops of mineral based oil such as engine oil in your brake system may damage the brake system parts.
- 

***i* Information**

Use only the brake fluid specified in the "Recommended Lubricants and Capacities" section in chapter 2.

---

**Gear Fluid**

There is no gear fluid level gauge in the vehicle. Check the gear fluid every 32,000 mi. (52,000 km) regularly. If the vehicle is driven under severe condition, check the maintenance under severe usage condition and consult an authorized HYUNDAI dealer.

## Washer Fluid

### Checking the Washer Fluid Level

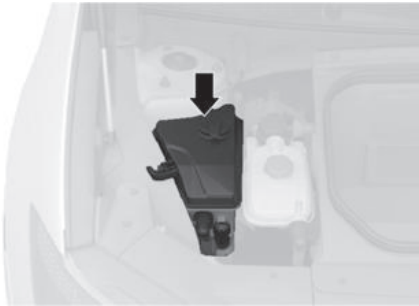

Check the fluid level in the washer fluid reservoir and add fluid if necessary. Plain water may be used if washer fluid is not available. However, use washer solvent with antifreeze characteristics in cold climates to prevent freezing.

#### **WARNING**

To prevent serious injury or death, take the following safety precautions when using washer fluid:

- Do not use coolant or antifreeze in the washer fluid reservoir. Coolant can severely obscure visibility when sprayed on the windshield and may cause loss of vehicle control resulting in an accident or damage to paint and body trim.
- Do not allow sparks or flame to contact the washer fluid or the washer fluid reservoir. Washer fluid may contain alcohol and can be flammable.
- Do not drink washer fluid and avoid contact with skin. Washer fluid is harmful to humans and animals.
- Keep washer fluid away from children and animals.

## Cabin Air Filter

### Filter Inspection

The cabin air filter must be replaced according to the Maintenance Schedule. If the vehicle is operated in severely air-polluted cities or on dusty rough roads for a long period, it should be inspected more frequently and replaced sooner. Replace the cabin air filter by following the procedure below and be careful to avoid damaging other components.

### Filter Replacement

1. Open the hood.
2. Lift up the front trunk cover while depressing the front trunk lever (1).



3. Press and hold the lock (2) on the left side of the cover (3).

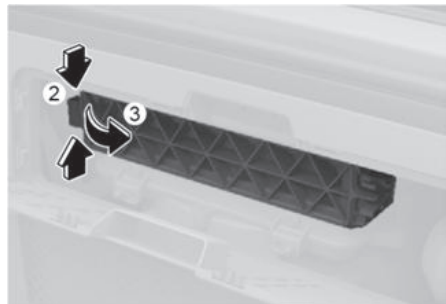

4. Replace the cabin air filter.



5. Reassemble in the reverse order of disassembly.



- Install a new cabin air filter with the arrow symbol (↓) facing down to improve effectiveness.
- Always be sure that the front trunk cover is firmly closed after replacing the cabin air filter.

Otherwise it may cause interior damage in the motor compartment, noise trouble, or entrance of foreign substances.

## Wiper Blades

### Blade Inspection

Contamination of either the windshield or the wiper blades with foreign matter can reduce the effectiveness of the windshield wipers.

Common sources of contamination are insects, tree sap, and hot wax treatments used by some commercial car washes. If the blades are not wiping properly, clean both the window and the blades with a good cleaner or mild detergent, and rinse thoroughly with clean water. Replace blades as needed.

#### NOTICE

To prevent damage to the wiper blades, arms or other components, do not:

- Use gasoline, kerosene, paint thinner, or other solvents on or near them.
- Attempt to move the wipers manually.

### Blade Replacement

When the wipers no longer clean adequately, the blades may be worn or cracked. Replace the wipers with new ones.

#### NOTICE

To prevent damage:

- Never use non-specified wiper blades.
- Lift the wiper arms when in the top wiping position.

Always return the wiper arms to the windshield before driving.

### Front windshield wiper blade replacement

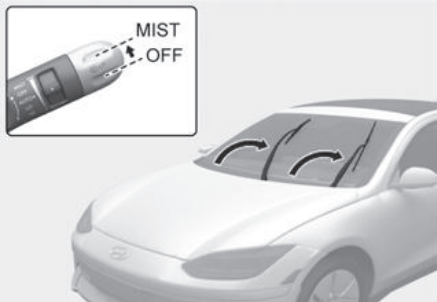

Within 20 seconds of turning off the vehicle, lift up and hold the wiper lever to the MIST position for about 2 seconds until the wipers move to the top wipe position.

Lift the wipers off the windshield.

#### Type A

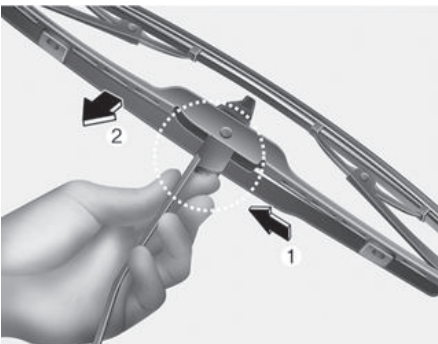

1. Lift up the wiper blade clip. Then lift up the wiper blade.
2. While pushing the lock (1), pull down the wiper blade (2).

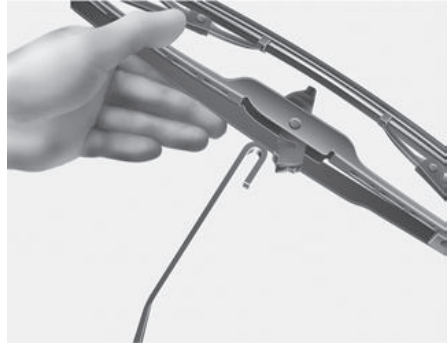

3. Remove the wiper blade from the wiper arm.
4. Install a new wiper blade assembly in the reverse order of removal.
5. Turn the wipers to any ON position to return the wiper arms to the bottom resting position.

#### Type B

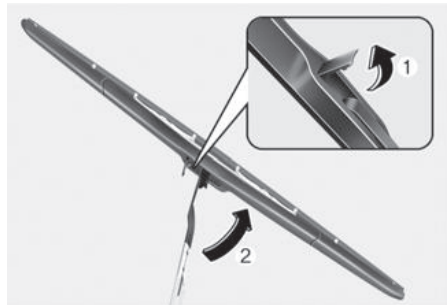

1. Lift up the wiper blade clip (1). Then lift up the wiper blade.



2. Press the clip (3). Then push the blade forward through the wiper arm to disassemble it (4).



3. Remove the wiper blade from the wiper arm (5).
4. Install the new blade assembly in the reverse order of removal.
5. Turn the wipers to any ON position to return the wiper arms to the bottom resting position.

## Battery (12 V)

### WARNING

To prevent **SERIOUS INJURY** or **DEATH** to you or bystanders, always follow these precautions when working near or handling the battery:



Always read and follow instructions carefully when handling a battery.



Wear eye protection designed to protect the eyes from acid splashes.



Keep all flames, sparks, or smoking materials away from the battery.



Hydrogen gas is always present in battery cells. It is highly combustible, and may explode if ignited.



Keep batteries out of reach of children.



Batteries contain sulfuric acid that is highly corrosive. Do not allow acid to contact your eyes, skin, or clothing.

If acid gets into your eyes, flush your eyes with clean water for at least 15 minutes and get immediate medical attention. If acid gets on your skin, thoroughly wash the area. If you feel pain or a burning sensation, get medical attention immediately.

- Lift a battery with a battery carrier or with your hands on opposite corners. When lifting a plastic-cased battery, excessive pressure on the case may cause battery acid to leak.
  - Do not attempt to jump start your vehicle if your battery is frozen.
  - NEVER attempt to recharge the battery when the vehicle's battery cables are connected to the battery.
  - The electrical ignition switch works with high voltage. NEVER touch these components with the Start/Stop button in the ON or START position.
- 

### **WARNING**

#### CALIFORNIA PROPOSITION 65 WARNING

Battery posts, terminals, and related accessories contain lead and lead compounds, chemicals known to the State of California to cause cancer, birth defects and reproductive harm. Batteries also contain other chemicals known to the State of California to cause cancer. Wash hands after handling.

---

### **NOTICE**

To prevent battery damage:

- When you do not use the vehicle for a long time in a low temperature area, disconnect the battery and keep it indoors.
  - Always fully charge the battery to prevent battery case damage in low temperature areas.
  - Prevent liquid from wetting the battery terminals.
  - Do not tilt the battery.
  - Never connect unauthorized devices to the battery.
-

## For Best Battery Service

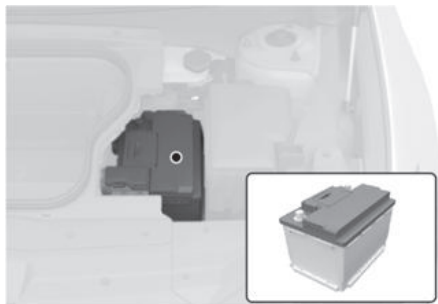

- Keep the battery securely mounted.
- Keep the battery top clean and dry.
- Keep the terminals and connections clean, tight, and coated with petroleum jelly or terminal grease.
- Rinse any spilled electrolyte from the battery immediately with a solution of water and baking soda.
- If the vehicle is not going to be used for an extended time, disconnect the battery cables.

## Battery Capacity Label

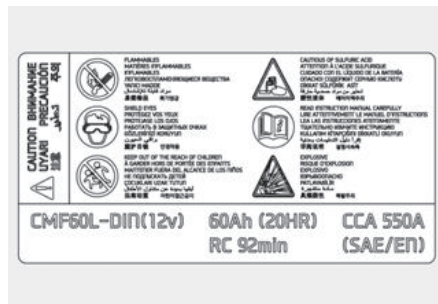

## i Information

The actual battery label in the vehicle may differ from the illustration.

1. CMF60L-DIN(12 v): The HYUNDAI model name of battery
2. 60Ah (20 HR): The nominal capacity (in Ampere hours)
3. 550 A: The cold-test current in amperes by SAE / EN
4. RC 92 min: The nominal reserve capacity (in minutes)

## Battery Recharging

### By battery charger

Your vehicle has a maintenance-free, calcium-based battery.

- If the battery becomes discharged over a short time (because, for example, the headlights or interior lights were left on while the vehicle was not in use), recharge it by slow charging (trickle) for 10 hours.
- If the battery gradually discharges because of high electrical load while the vehicle is being used, recharge it at 20-30 A for two hours.

### **WARNING**

Always follow these instructions when recharging your vehicle's battery to avoid the risk of **SERIOUS INJURY** or **DEATH** from explosions or acid burns:

- Before performing maintenance or recharging the battery, turn off all accessories and stop the vehicle.
- Keep all flames, sparks, or smoking materials away from the battery.
- Always work outdoors or in an area with plenty of ventilation.
- Wear eye protection when checking the battery during charging.
- The battery must be removed from the vehicle and placed in a well ventilated area.
- Watch the battery during charging, and stop or reduce the charging rate if the battery cells begin boiling violently.
- Remove the negative battery cable first and install it last when the battery is disconnected. Disconnect the battery charger in the following order:
  1. Turn off the battery charger main switch.
  2. Unhook the negative clamp from the negative battery terminal.
  3. Unhook the positive clamp from the positive battery terminal.

### ***By jump starting***

After a jump start from a good battery, drive the vehicle for 20-30 minutes before it is shutoff. The vehicle may not restart if you shut it off before the battery had a chance to adequately recharge. For more information, refer to the "Jump Starting (12 V battery)" section in chapter 8 for more information on jump starting procedures.

### *i* **Information**



An inappropriately disposed battery can be harmful to the environment and human health. Dispose of the battery according to your local law(s) or regulation.

### **Reset Items**

The following items may need to be reset after the battery has been discharged or the battery has been disconnected:

- Drive info/After Recharging/Accumulated info (items in View modes) (refer to chapter 4)
- Integrated Memory System (refer to chapter 5)
- Power Windows (refer to chapter 5)
- Wide Sunroof (if equipped) (refer to chapter 5)
- Power Trunk (refer to chapter 5)
- Automatic Climate Control System (refer to chapter 5)
- Clock (refer to the Infotainment system manual)
- Infotainment System (refer to the Infotainment system manual)

## Tires and Wheels

### WARNING

Tire failure may cause loss of vehicle control resulting in an accident. To reduce risk of **SERIOUS INJURY** or **DEATH**, take the following precautions:

- Inspect your tires monthly for proper inflation as well as wear and damage.
- The recommended cold tire pressure for your vehicle can be found in this manual and on the tire label located on the driver's side center pillar. Always use a tire pressure gauge to measure tire pressure. Tires with too much or too little pressure wear unevenly causing poor handling.
- Check the pressure of the spare every time you check the pressure of the other tires on your vehicle.
- Replace tires that are worn, show uneven wear, or are damaged. Worn tires can cause loss of braking effectiveness, steering control, or traction.
- **ALWAYS** replace tires with the same size, type, construction and tread pattern as each tire that was originally supplied with this vehicle. Using tires and wheels other than the recommended sizes could cause unusual handling characteristics, poor vehicle control, or negatively affect your vehicle's Anti-Lock Brake System (ABS) resulting in a serious accident.

## Tire Care

For proper maintenance, safety, and maximum electric energy economy, you must always maintain recommended tire inflation pressures and stay within the load limits and weight distribution recommended for your vehicle.



All specifications (sizes and pressures) can be found on a label attached to the driver's side center pillar.

## Recommended Cold Tire Inflation Pressures

All tire pressures (including the spare) should be checked when the tires are cold. "Cold tires" means the vehicle has not been driven for at least three hours or driven less than one mile (1.6 km).

Warm tires normally exceed recommended cold tire pressures by 4 to 6 psi (28 to 41 kPa). Do not release air from warm tires to adjust the pressure or the tires will be under-inflated. For recommended inflation pressure, refer to the "Tires and Wheels" section in chapter 2.



## WARNING

- Recommended pressures must be maintained for the best ride, vehicle handling, and minimum tire wear.
  - Over-inflation or under-inflation can reduce tire life, adversely affect vehicle handling, and lead to sudden tire failure that may result in loss of vehicle control resulting in a collision.
  - Severe under-inflation may lead to severe heat build-up, causing blowouts, tread separation, and other tire failures that result in loss of vehicle control resulting in a collision. This risk is much higher on hot days and when driving for a long time at high speeds.
  - Under-inflation may cause excessive wear, poor handling, and reduced fuel economy. Wheel deformation is also possible. Keep your tire pressures at the proper levels. If a tire frequently needs refilling, have it inspected by an authorized HYUNDAI dealer.
  - Over-inflation produces a harsh ride, excessive wear at the center of the tire tread, and a greater possibility of damage from road hazards.
- 

## Check Tire Inflation Pressure

Check your tires, including the spare tire, once a month or more.

### ***How to check***

Use a good quality tire pressure gauge to check tire pressure. You can not tell if your tires are properly inflated simply by looking at them. Radial tires may look properly inflated when they are under-inflated.

Remove the valve cap from the tire valve stem. Press the tire gauge firmly onto the valve to get a pressure measurement. If the cold tire inflation pressure matches the recommended pressure on the tire and loading information label, no further adjustment is necessary. If the pressure is low, add air until you reach the recommended pressure. Make sure to put the valve caps back on the valve stems. Without the valve cap, dirt or moisture could get into the valve core and cause air leakage. If a valve cap is missing, install a new one as soon as possible.

If you overfill the tire, release air by pushing on the metal stem in the center of the tire valve. Recheck the tire pressure with the tire gauge. Be sure to put the valve caps back on the valve stems. Without the valve cap, dirt or moisture could get into the valve core and cause air leakage. If a valve cap is missing, install a new one as soon as possible.



## Tire Rotation

To equalize tread wear, HYUNDAI recommends that the tires be rotated according to the maintenance schedule or sooner if irregular wear develops.

During rotation, check the tires for correct balance.

When rotating tires, check for uneven wear and damage. Abnormal wear is usually caused by incorrect tire pressure, improper wheel alignment, out-of-balance wheels, severe braking or severe cornering. Look for bumps or bulges in the tread or side of the tire. Replace the tire if you find any of these conditions. Replace the tire if fabric or cord is visible. After rotation, be sure to bring the front and rear tire pressures to specification and check wheel lug nut tightness (proper torque is 79-94 lbf-ft (11-13kgf-m)).

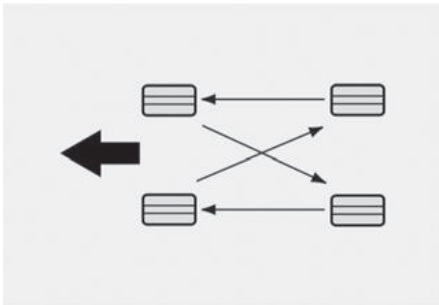

Disc brake pads should be inspected for wear whenever tires are rotated.

### *i* Information

When installing an unsymmetrical tire, install the side marked “outside” facing out.

### WARNING

- Do not use the compact spare tire for tire rotation.
- Do not mix bias ply and radial ply tires under any circumstances. This may cause unusual handling characteristics that may cause loss of vehicle control resulting in an collision.

## Wheel Alignment and Tire Balance

The wheels on your vehicle were aligned and balanced carefully at the factory to give you the longest tire life and best overall performance.

In most cases, you will not need to have your wheels aligned again. However, if you notice unusual tire wear or your vehicle pulling one way or the other, the alignment may need to be reset.

If you notice your vehicle vibrating when driving on a smooth road, your wheels may need to be rebalanced.

### **NOTICE**

Only use approved wheel weights or your vehicle's aluminum wheels may be damaged.

## Tire Replacement



### [A] Tread wear indicator

If the tire is worn evenly, a tread wear indicator will appear as a solid band across the tread. This shows there is less than 1/16 in. (1.6 mm) of tread left on the tire. Replace the tire when this happens.

Do not wait for the band to appear across the entire tread before replacing the tire.

### WARNING

To reduce the risk of DEATH or SERIOUS INJURY:

- Replace tires that are worn, show uneven wear, or are damaged. Worn tires can cause loss of braking effectiveness, steering control, and traction.
- Always replace tires with the same size as each tire that was originally supplied with this vehicle. Using tires and wheels other than the recommended sizes could cause unusual handling characteristics, poor vehicle control, or negatively affect your vehicle's Anti-Lock Brake System (ABS) resulting in a serious accident.
- When replacing tires (or wheels), it is recommended to replace the two front or two rear tires (or wheels) as

a pair. Replacing just one tire can seriously affect your vehicle's handling.

- Tires degrade over time, even when they are not being used. Regardless of the remaining tread, HYUNDAI recommends that tires be replaced after six (6) years of normal service.
- Heat caused by hot climates or frequent high loading conditions can accelerate the aging process. Failure to follow this warning may cause sudden tire failure, which could lead to a loss of vehicle control resulting in an accident.

### WARNING

The original tire should be repaired or replaced as soon as possible to avoid failure of the spare and loss of vehicle control resulting in an accident. The compact spare tire is for emergency use only. Do not operate your vehicle over 50 mph (80 km/h) when using the compact spare tire.

## Wheel Replacement

When replacing the metal wheels for any reason, make sure the new wheels are equivalent to the original factory units in diameter, rim width, and offset.

## Tire Traction

Tire traction can be reduced if you drive on worn tires, tires that are improperly inflated or on slippery road surfaces. Tires should be replaced when tread wear indicators appear. To reduce the possibility of losing control, slow down whenever there is rain, snow or ice on the road.

## Tire Maintenance

In addition to proper inflation, correct wheel alignment helps to decrease tire wear. If you find a tire is worn unevenly, have your dealer check the wheel alignment.

When you have new tires installed, make sure they are balanced. This will increase vehicle ride comfort and tire life. Additionally, a tire should always be rebalanced if it is removed from the wheel.

## Tire Sidewall Labeling

This information identifies and describes the fundamental characteristics of the tire and also provides the Tire Identification Number (TIN) for safety standard certification. The TIN can be used to identify the tire in case of a recall.

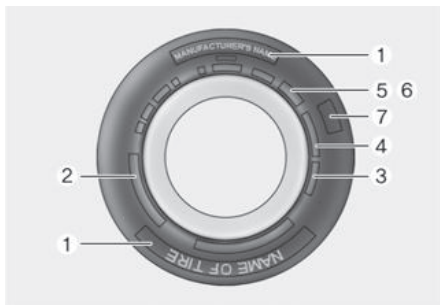

### 1. Manufacturer or brand name

Manufacturer or brand name is shown.

### 2. Tire size designation

A tire's sidewall is marked with a tire size designation. You will need this information when selecting replacement tires for your car. The following explains what the letters and numbers in the tire size designation mean.

Example tire size designation:

(These numbers are provided as an example only; your tire size designator could vary depending on your vehicle.)

#### **245/40R20 99W**

245 - Tire width in millimeters.

40 - Aspect ratio. The tire's section height as a percentage of its width.

R - Tire construction code (Radial).

20 - Rim diameter in in.

99 - Load Index, a numerical code associated with the maximum load the tire can carry.

W - Speed Rating Symbol. See the speed rating chart in this section for additional information.

### Wheel size designation

Wheels are also marked with important information that you need if you ever have to replace one. The following explains what the letters and numbers in the wheel size designation mean.

Example wheel size designation:

#### **8.5 X 20**

8.5 - Rim width in inches.

J - Rim contour designation.

20 - Rim diameter in inches.

### Tire speed ratings

The chart below lists many of the different speed ratings currently being used for passenger vehicle tires. The speed rating is part of the tire size designation on the sidewall of the tire. This symbol corresponds to that tire's designed maximum safe operating speed.

Speed Rating Symbol	Maximum Speed
S	112 mph (180 km/h)
T	118 mph (190 km/h)
H	130 mph (210 km/h)
V	149 mph (240 km/h)
W	168 mph (270 km/h)
Y	186 mph (300 km/h)

### 3. Checking tire life (TIN: Tire Identification Number)

Any tires that are over six years old, based on the manufacturing date, (including the spare tire) should be replaced by new ones. You can find the manufacturing date on the tire sidewall (possibly on the inside of the wheel), displaying the DOT Code. The DOT Code is a series of numbers on a tire consisting of numbers and English letters. The manufacturing date is designated by the last four digits (characters) of the DOT code.

#### **DOT: XXXX XXXX OOOO**

The front part of the DOT shows a plant code number, tire size and tread pattern and the last four numbers indicate week and year manufactured.

For example:

DOT XXXX XXXX 1524 represents that the tire was produced in the 15th week of 2024.

### 4. Tire ply composition and material

The number of layers or plies of rubber-coated fabric in the tire. Tire manufacturers also must indicate the materials in the tire, which include steel, nylon, polyester, and others. The letter “R” means radial ply construction; the letter “D” means diagonal or bias ply construction; and the letter “B” means belted-bias ply construction.

### **5. Maximum permissible inflation pressure**

This number is the greatest amount of air pressure that should be put in the tire. Do not exceed the maximum permissible inflation pressure. Refer to the Tire and Loading Information label for recommended inflation pressure.

### **6. Maximum load rating**

This number indicates the maximum load in kilograms and lbs. that can be carried by the tire. When replacing the tires on the vehicle, always use a tire that has the same load rating as the factory installed tire.

### **Uniform tire quality grading**

Quality grades can be found where applicable on the tire sidewall between tread shoulder and maximum section width.

For example:

TREADWEAR 200

TRACTION AA

TEMPERATURE A

### **Tread wear**

The tread wear grade is a comparative rating based on the wear rate of the tire when tested under controlled conditions on a specified government test course. For example, a tire graded 150 would wear one-and-a-half times (1½) as well on the government course as a tire graded 100.

The relative performance of tires depends upon the actual conditions of their use, however, and may depart significantly from the norm due to variations in driving habits, service practices and differences in road characteristics and climate.

These grades are molded on the sidewalls of passenger vehicle tires. The tires available as standard or optional equipment on your vehicle may vary with respect to grade.

### **Traction - AA, A, B & C**

The traction grades, from highest to lowest, are AA, A, B and C. Those grades represent the tire's ability to stop on wet pavement as measured under controlled conditions on specified government test surfaces of asphalt and concrete. A tire marked C may have poor traction performance.

### **WARNING**

The traction grade assigned to this tire is based on straight ahead braking traction tests, and does not include acceleration, cornering, hydroplaning, or peak traction characteristics.

### **Temperature - A, B & C**

The temperature grades are A (the highest), B and C representing the tire's resistance to the generation of heat and its ability to dissipate heat when tested under controlled conditions on a specified indoor laboratory test wheel.

Sustained high temperature can cause the material of the tire to degenerate and reduce tire life, and excessive temperature can lead to sudden tire failure. Grades B and A represent higher levels of performance on the laboratory test wheel than the minimum required by law.

#### **WARNING**

The temperature grade for this tire is established for a tire that is properly inflated and not overloaded. Excessive speed, under-inflation, over-inflation, or excessive loading, either separately or in combination, can cause heat build-up and possible sudden tire failure. This may cause loss of vehicle control resulting in an accident.

---

## **Tire Terminology and Definitions**

### ***Air pressure***

The amount of air inside the tire pressing outward on the tire. Air pressure is expressed in lbs. per square in. (psi) or kilopascal (kPa).

### ***Accessory weight***

This means the combined weight of optional accessories. Some examples

of optional accessories are gear, power seats, and air conditioning.

### ***Aspect ratio***

The relationship of a tire's height to its width.

### ***Belt***

A rubber coated layer of cords that is located between the plies and the tread. Cords may be made from steel or other reinforcing materials.

### ***Bead***

The tire bead contains steel wires wrapped by steel cords that hold the tire onto the rim.

### ***Bias ply tire***

A pneumatic tire in which the plies are laid at alternate angles less than 90 degrees to the centerline of the tread.

### ***Cold tire pressure***

The amount of air pressure in a tire, measured in lbs. per square in. (psi) or kilopascals (kPa) before a tire has built up heat from driving.

### ***Curb weight***

This means the weight of a motor vehicle with standard and optional equipment including the maximum capacity of fuel, oil and coolant, but without passengers and cargo.

**DOT markings**

A code molded into the sidewall of a tire signifying that the tire is in compliance with the U.S. Department of Transportation motor vehicle safety standards. The DOT code includes the Tire Identification Number (TIN), an alphanumeric designator which can also identify the tire manufacturer, production plant, brand and date of production.

**GVWR**

Gross Vehicle Weight Rating

**GAWR FRT**

Gross Axle Weight Rating for the Front Axle.

**GAWR RR**

Gross Axle Weight Rating for the Rear axle.

**Intended outboard sidewall**

The side of an asymmetrical tire, that must always face outward when mounted on a vehicle.

**Kilopascal (kPa)**

The metric unit for air pressure.

**Light Truck (LT) tire**

A tire designated by its manufacturer as primarily intended for use on lightweight trucks or multipurpose passenger vehicles.

**Load ratings**

The maximum load that a tire is rated to carry for a given inflation pressure.

**Load index**

An assigned number ranging from 1 to 279 that corresponds to the load carrying capacity of a tire.

**Maximum inflation pressure**

The maximum air pressure to which a cold tire may be inflated. The maximum air pressure is molded onto the sidewall.

**Maximum load rating**

The load rating for a tire at the maximum permissible inflation pressure for that tire.

**Maximum loaded vehicle weight**

The sum of curb weight; accessory weight; vehicle capacity weight; and production options weight.

**Normal occupant weight**

The number of occupants a vehicle is designed to seat multiplied by 150 lbs. (68 kg).

**Occupant distribution**

Designated seating positions.

**Outward facing sidewall**

An asymmetrical tire has a particular side that faces outward when mounted on a vehicle. The outward facing sidewall bears white lettering or bears manufacturer, brand, and/or model name molding that is higher or deeper than the same moldings on the inner facing sidewall.

**Passenger (P-Metric) tire**

A tire used on passenger cars and some light duty trucks and multipurpose vehicles.

**Ply**

A layer of rubber-coated parallel cords.

**Pneumatic tire**

A mechanical device made of rubber, chemicals, fabric and steel or other materials, that, when mounted on an automotive wheel provides the traction and contains the gas or fluid that sustains the load.

**Pneumatic options weight**

The combined weight of installed regular production options weighing over 5 lbs. (2.3 kg) in excess of the standard items which they replace, not previously considered in curb weight or accessory weight, including heavy duty breaks, ride levelers, roof rack, heavy duty battery, and special trim.

**Recommended inflation pressure**

Vehicle manufacturer's recommended tire inflation pressure as shown on the tire placard.

**Radial ply tire**

A pneumatic tire in which the ply cords that extend to the beads are laid at 90 degrees to the centerline of the tread.

**Rim**

A metal support for a tire and upon which the tire beads are seated.

**Sidewall**

The portion of a tire between the tread and the bead.

**Speed rating**

An alphanumeric code assigned to a tire indicating the maximum speed at which a tire can operate.

**Traction**

The friction between the tire and the road surface. The amount of grip provided.

**Tread**

The portion of a tire that comes into contact with the road.

**Treadwear indicators**

Narrow bands, sometimes called "wear bars", that show across the tread of a tire when only 1/16 in. of tread remains.

**UTQGS**

Uniform Tire Quality Grading Standards is a tire information system that provides consumers with ratings for a tire's traction, temperature and treadwear. Ratings are determined by tire manufacturers using government testing procedures. The ratings are molded into the sidewall of the tire.

**Vehicle capacity weight**

The number of designated seating positions multiplied by 150 lbs. (68 kg) plus the rated cargo and luggage load.



**Vehicle maximum load on the tire**

Load on an individual tire due to curb and accessory weight plus maximum occupant and cargo weight.

**Vehicle normal load on the tire**

Load on an individual tire that is determined by distributing to each axle its share of the curb weight, accessory weight, and normal occupant weight and dividing by 2.

**Vehicle placard**

A label permanently attached to a vehicle showing the original equipment tire size and recommended inflation pressure.

**All Season Tires**

HYUNDAI specifies all season tires on some models to provide good performance for use all year round, including snowy and icy road conditions. All season tires are identified by ALL SEASON and/or M+S (Mud and Snow) on the tire sidewall. Snow tires have better snow traction than all season tires and may be more appropriate in some areas.

**Summer Tires**

HYUNDAI specifies summer tires on some models to provide superior performance on dry roads. Summer tire performance is substantially reduced in snow and ice. Summer tires do not have the tire traction rating M+S (Mud and Snow) on the tire side wall. If you plan to operate your vehicle in snowy or icy conditions, HYUNDAI recommends the use of snow tires or all season tires on all four wheels.

**Snow Tires**

If you equip your car with snow tires, they should be the same size and have the same load capacity as the original tires. Snow tires should be installed on all four wheels; otherwise, poor handling may result. Snow tires should carry 4 psi (28 kPa) more air pressure than the pressure recommended for the standard tires on the tire label on the driver's side of the center pillar, or up to the maximum pressure shown on the tire sidewall, whichever is less. Do not drive faster than 75 mph (120 km/h) when your vehicle is equipped with snow tires.

**Radial-Ply Tires**

Radial-ply tires provide improved tread life, road hazard resistance and smoother high speed ride. The radial-ply tires used on this vehicle are of belted construction, and are selected to complement the ride and handling characteristics of your vehicle. Radial-ply tires have the same load carrying capacity, as bias-ply or bias belted tires of the same size, and use the same recommended inflation pressure. Mixing of radial-ply tires with bias-ply or bias belted tires is not recommended. Any combinations of radial-ply and bias-ply or bias belted tires when used on the same vehicle will seriously deteriorate vehicle handling. The best rule to follow is: Identical pairs of radial-ply tires should always be used as a set for the front tires and a set for the rear tires. Longer wearing tires can be more susceptible to irregular tread wear. It is very important to follow the tire

rotation interval in this chapter to achieve the tread life potential of these tires. Cuts and punctures in radial-ply tires are repairable only in the tread area, because of sidewall flexing. Consult your tire dealer for radial-ply tire repairs.

### **WARNING**

Do not mix bias ply and radial ply tires under any circumstances. This may cause unusual handling characteristics that may cause loss of vehicle control resulting in an accident.

---

### Low Aspect Ratio Tires

 If equipped

The aspect ratio is lower than 50 on low aspect ratio tires.

Because low aspect ratio tires are optimized for handling and braking, their sidewall is a little stiffer than a standard tire. Also, low aspect ratio tires tend to be wider so that they consequently have increased contact with the road surface. In some instances, low aspect ratio tires may generate more road noise compared with standard tires.

### **NOTICE**

Low-aspect wheels and tires are easily damaged. To reduce the risk of damage:

- When driving on rough roads, passing over a pothole, speed bump, manhole, or curb stone, drive the vehicle slowly not to damage the tires and wheels. Damage is not covered by your vehicle warranty.
  - Inspect the tire condition and pressure every 1,800 mi. (3,000 km).
  - It is difficult to visually inspect for tire damage with your eyes. If any damage is found, contact your authorized HYUNDAI dealer to replace the tire.
-

## Fuses

Blade type



Cartridge type

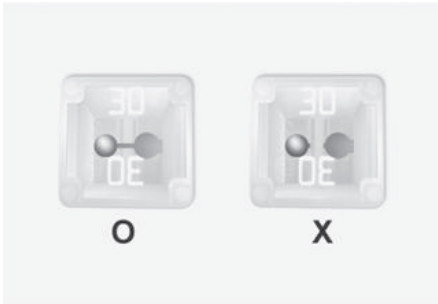

Multi type

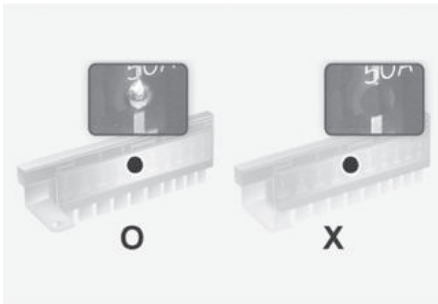

A vehicle's electrical system is protected from electrical overload damage by fuses. This vehicle has 2 (or 3) fuse panels, one located in the driver's side panel bolster, the other in the vehicle compartment.

If any of your vehicle's lights, accessories, or controls do not work, check the appropriate circuit fuse. If a fuse has blown, the element inside the fuse will be melted or broken.

If the electrical system does not work, first check the driver's side fuse panel. Before replacing a blown fuse, turn the vehicle and all switches off, and then disconnect the negative battery cable. Always replace a blown fuse with one of the same rating.

If the replacement fuse blows, this indicates an electrical problem. Avoid using the system involved. Consult an authorized HYUNDAI dealer.

### WARNING

NEVER replace a fuse with anything but another fuse of the same rating.

- A higher capacity fuse may cause damage and possibly cause a fire.
- Do not install a wire or aluminum foil instead of the proper fuse - even as a temporary repair. It may cause extensive wiring damage and possibly a fire.

### NOTICE

Do not use a screwdriver or any other metal object to remove fuses because it may cause a short circuit and damage the system.

## Instrument Panel Fuse Replacement

Driver's side



1. Turn off the vehicle.
2. Turn off all other switches.
3. Open the fuse panel cover.
4. Refer to the label on the inside of the fuse panel cover to locate the suspected fuse location.

Motor compartment

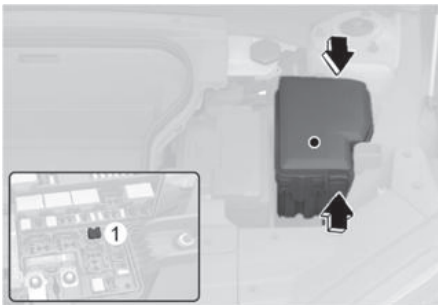

5. Pull the suspected fuse straight out. Use the removal tool (1) provided in the motor compartment fuses panel.
6. Check the removed fuse and replace it if it is blown. Spare fuses are provided in the instrument panel fuse panels (or in the motor compartment fuse panel).
7. Push in a new fuse of the same rating, and make sure it fits tightly in the clips. If it is not tight, contact consult an authorized HYUNDAI dealer.

In an emergency, if you do not have a spare fuse, use a fuse of the same rating from a circuit you may not need for operating the vehicle.

If the headlights or other electrical components do not work and the fuses are undamaged, check the fuse panel in the motor compartment.

## Motor Compartment Panel Fuse Replacement

### Blade fuse/Cartridge fuse

Blade type fuse

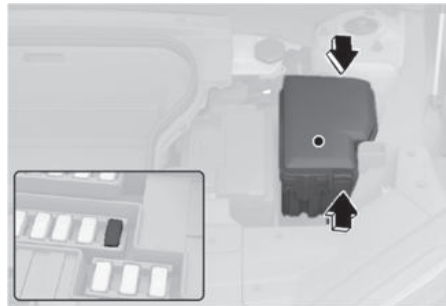

Cartridge type fuse

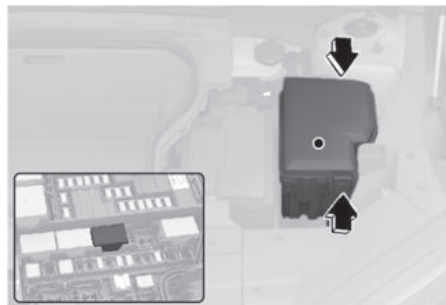

1. Turn off the vehicle.
2. Turn off all other switches.
3. Remove the fuse panel cover by pressing the tap and pulling up.

4. Check the removed fuse and replace it if it is blown. To remove or insert the fuse, use the fuse puller in the motor compartment fuse panel.
5. Push in a new fuse of the same rating, and make sure it fits tightly in the clips. If it is not tight, contact consult an authorized HYUNDAI dealer.

### **NOTICE**

Always securely install the fuse panel cover. Water may contact the fuse and cause an electrical failure.

### **Multi fuse**

Multi type

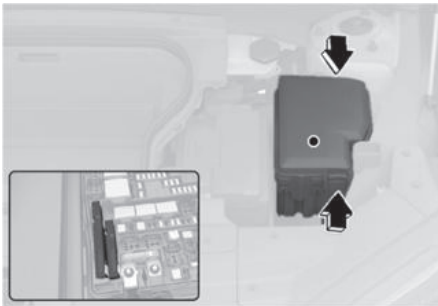

If the multi fuse is blown, contact an authorized HYUNDAI dealer.

## Fuse/Relay Panel Description

### Instrument panel fuse panel



Inside the fuse panel cover, you can find the fuse label describing fuse names and ratings.

### **i** Information

Not all fuse panel descriptions in this manual may be applicable to your vehicle. When you inspect the fuse panel on your vehicle, refer to the fuse panel label.

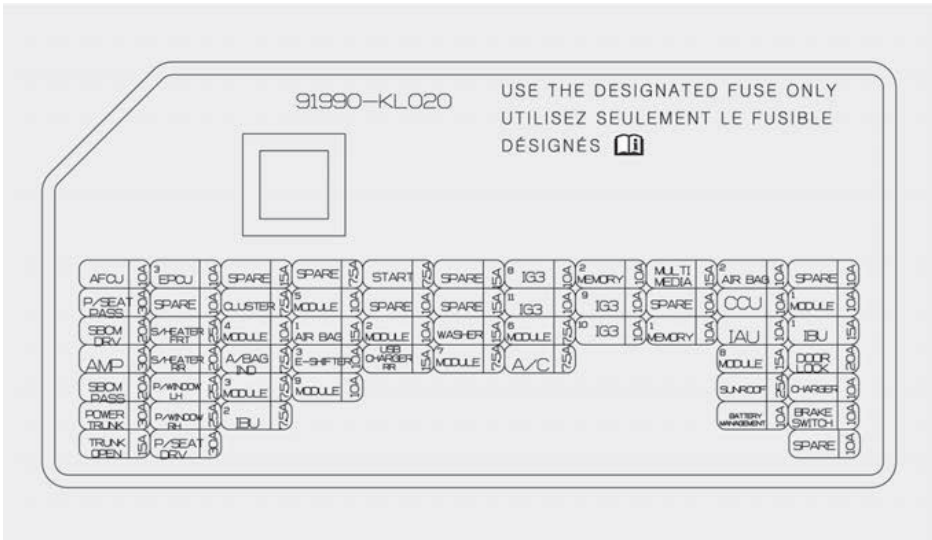

### Instrument panel fuse panel

Fuse Name	Fuse Rating	Circuit Protected
AFCU	10 A	Driver/Passenger Door Outside Handle
EPCU3	10 A	Rear Inverter
START	7.5 A	IBU, VCU
IG3 8	10 A	In-car Temperature Sensor, A/C Control Module, A/C PTC Heater, Instrument Cluster, CCU, AVNT Head Unit
MEMORY 2	10 A	Instrument Cluster, ADAS Unit (Parking)
MULTIMEDIA	15 A	AVNT Head Unit
AIRBAG2	10 A	SRS Control Module
P/SEAT PASS	30 A	Passenger Power Seat Switch, Passenger Seat Unit
ADAS DRV	10 A	Not Used
CLUSTER	7.5 A	Instrument Cluster, Head-Up Display
MODULE5	10 A	Data Link Connector, Electro Chromic Mirror, AVNT Head Unit, IFS Unit, Wireless Charger Unit, Head Light LH/RH, AMP, Driver IMS Module, Front Air Ventilation Seat Control Module, Front Seat Warmer Control Module, Passenger Seat Unit, Rear Seat Warmer Control Module, ADP Unit (Acoustic Design Processor)
IG3 11	10 A	Electronic A/C Compressor
IG3 9	10 A	Rear Inverter, BMU
wireless DCU1	10 A	Not Used
CCU	10 A	CCU
MODULE1	10 A	Data Link Connector, Hazard Switch, Multifunction Switch, Rain Sensor, Driver Power Window Switch, Dashboard Mood Light, A/C Control Module, Outside Mirror Switch, UIP Sensor, UIP Siren, Power Trunk Unit, Driver/Passenger Door Mood Light #1/#2, Rear Door Mood Light LH/RH #1/#2
SBCM DRV	20 A	Driver Side Body Control Module
S/HEATER FRT	25 A	Front Air Ventilation Seat Control Module, Front Seat Warmer Control Module

Fuse Name	Fuse Rating	Circuit Protected
MODULE4	10 A	Front/Rear Corner Radar LH/RH, Rear Inverter (System), Front View Camera, IBU, ADAS Unit (Parking/Driving), Dashboard Switch, VESS Unit, Front Radar
AIRBAG1	15 A	SRS Control Module
MODULE2	10 A	ADP Unit (Acoustic Design Processor), AMP, IBU, CCU, DCU, P/R Junction Block (RLY. 5), AVNT Head Unit, AVNT Keyboard, ADAS Unit (Parking), IAU (Identity Authentication Unit)
WASHER	15 A	Multifunction Switch
MODULE6	7.5 A	IBU
IG3 10	10 A	SCU, Rear Electronic Oil Pump, VCMS, V2L Unit, ICCU
MEMORY1	10 A	DCU, A/C Control Module, Head-Up Display, ADP Unit (Acoustic Design Processor), Mood Lamp Unit
IAU	10 A	IAU (Identity Authentication Unit)
IBU1	15 A	IBU
AMP	30 A	AMP
S/HEATER RR	20 A	Rear Seat Warmer Control Module
A/BAG IND	7.5 A	Overhead Console Assembly
E-SHIFTER3	10 A	Electronic Shift Switch
RR USB CHARGER	25 A	Console/Rear USB Charger Connector
MODULE7	7.5 A	Rear Seat Warmer Control Module
A/CON	7.5 A	A/C Control Module
MODULE8	15 A	Driver IMS Module, Passenger Seat Unit
DOOR LOCK	20 A	Door Lock/Unlock Relay, Dead Lock Relay
SBCM PASS	20 A	Passenger Side Body Control Module
P/WINDOW LH	25 A	Rear Power Window Switch LH, Rear Safety Power Window Module LH, Driver Power Window Module, Driver/Passenger Safety Power Window Module
MODULE3	7.5 A	Stop Light Switch, Driver Power Window Switch, IAU (Identity Authentication Unit)



Fuse Name	Fuse Rating	Circuit Protected
CCU2	10 A	CCU, DCU
SUNROOF	25 A	Sunroof Glass Motor, Sunroof Blind Motor
CHARGER	10 A	VCMS, ICCU, Charger Connector Lock/Unlock Relay
MODULE9	10 A	CCU
TRUNK OPEN	15 A	Not Used
PTL	30 A	Power trunk Unit
P/WINDOW RH	25 A	Rear Power Window Switch LH, Rear Safety Power Window Module LH, Driver Power Window Module, Driver/Passenger Safety Power Window Module
IBU2	7.5 A	IBU
BMS	10 A	BMU
BRAKE SWITCH	10 A	Stop Light Switch, IBU
P/SEAT DRV	30 A	Driver Power Seat Switch, Driver IMS Module

**Motor compartment fuse panel**

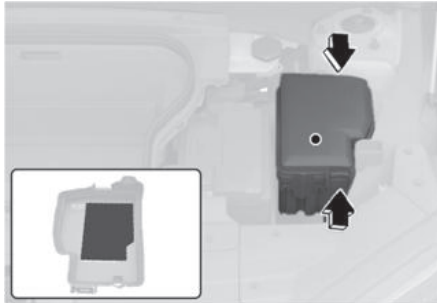

Inside the fuse panel cover, you can find the fuse label describing fuse names and ratings.

**i Information**

Not all fuse panel descriptions in this manual may be applicable to your vehicle. When you inspect the fuse panel on your vehicle, refer to the fuse panel label.

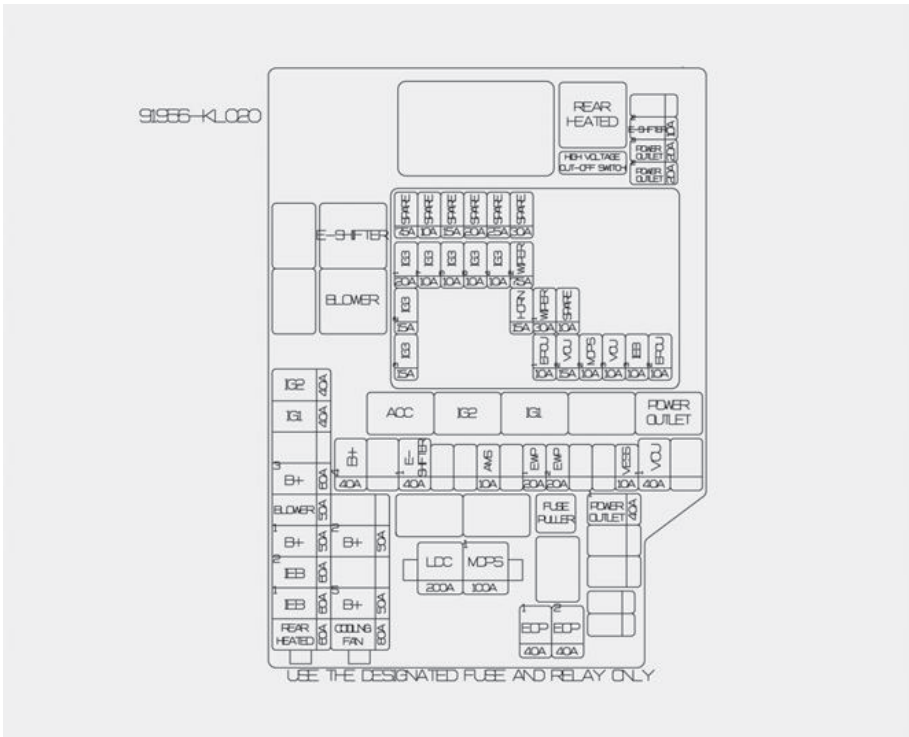

### Motor compartment fuse panel

Type	Fuse Name	Fuse Rating	Circuit Protected
MULTI FUSE-1	LDC1	200 A	ICCU (LDC), P/R Junction Block (Fuse : POWER OUTLET1, EOP1, EOP2, LDC2)
	MDPS1	100 A	MDPS Unit
MULTI FUSE-2	COOLING FAN	80 A	Cooling Fan Motor
	B+5	50 A	PCB Block (Main Relay, Fuse : VCU2, EPCU1, WIPER1, B/A HORN, HORN)
	B+2	50 A	ICU Junction Block (Fuse : IPS5, IPS7, IPS8, IPS9)
MULTI FUSE-3	RR HTD	60 A	P/R Junction Block (RLY. 10)
	IEB1	60 A	IEB Unit
	IEB2	50 A	IEB Unit
	B+1	50 A	ICU Junction Block (Fuse : IPS1, IPS2, IPS3, IPS4, IPS6)
	BLOWER	50 A	P/R Junction Block (RLY. 9)
	B+3	60 A	ICU Junction Block (Fuse : F1, F2, F12, F13, F23, F24, F34, F35, F43, F44, F49, F50, F55)
	IG1	40 A	P/R Junction Block (RLY. 1, RLY. 3)
	IG2	40 A	P/R Junction Block (RLY. 2)

Type	Fuse Name	Fuse Rating	Circuit Protected
FUSE	B+4	40 A	ICU Junction Block (Long Term Load Latch Relay, Fuse : F10, F11, F21, F22, F33, F41, F42, F47, F48, F52, F53)
	E-SHIFTER1	40 A	P/R Junction Block (RLY. 8, Fuse : F13)
	AMS	10 A	12 V Battery
	EWP1	20 A	Electronic Water Pump #1 (HV Battery)
	EWP2	20 A	Electronic Water Pump #2 (HV Battery)
	VESS	10 A	VESS Unit
	VCU1	40 A	VCU
	POWER OUTLET1	40 A	P/R Junction Block (RLY. 5)
	EOP1	40 A	Rear Electronic Oil Pump
	EOP2	40 A	Front Electronic Oil Pump
	E-SHIFTER2	10 A	SCU, Electronic Shift Switch, P/R Junction Block (RLY. 8)
	POWER OUTLET3	20 A	Rear Power Outlet
	POWER OUTLET2	20 A	Front Power Outlet

Fuse Name	Fuse Rating	Circuit Protected
IG3 1	20 A	ICU Junction Block (Fuse: F7, F18, F19, F30)
IG3 2	15 A	Front Inverter (AWD)
IG3 3	15 A	Electronic Water Pump
IG3 4	10 A	VCU
IG3 5	10 A	A/C Coolant Valve, Electronic Water Pump Batt #1, #2
IG3 6	10 A	BMS Coolant 3Way Valve
IG3 7	10 A	Cooling Fan Motor, Front Electronic Oil Pump (AWD)
EPCU1	10 A	Front Inverter (AWD)
EPCU2	10 A	Front Inverter (AWD)
VCU2	10 A	VCU
VCU3	10 A	VCU
WIPER1	30 A	PCB Block (Wiper Main Relay)
WIPER2	7.5 A	IBU
HORN	10 A	PCB Block (Horn Relay)
IEB3	10 A	IEB Unit
MDPS2	10 A	MDPS Unit

## Light Bulbs

Consult an authorized HYUNDAI dealer to replace most vehicle light bulbs. It is difficult to replace vehicle light bulbs because other parts of the vehicle must be removed before you can get to the bulb. This is especially true for removing the headlight assembly to get to the bulb(s).

Removing/installing the headlight assembly can result in damage to the vehicle.

### WARNING

- Prior to replacing a light bulb, depress the brake pedal, shift to P (Park), apply the parking brake, press the Start/Stop button to the OFF position, and take the key with you when leaving the vehicle to avoid sudden movement of the vehicle and to prevent possible electric shock.
  - Be aware the bulbs may be hot and may burn your fingers.
- 

### NOTICE

Be sure to replace the burned-out bulb with one of the same wattage to prevent damage to the fuse or electrical wiring system.

---

### NOTICE

To prevent damage, do not clean the headlight lens with chemical solvents or strong detergents.

---

### *i* Information

#### Headlight desiccant

This vehicle is equipped with desiccant to reduce fogging inside the headlight due to moisture. The desiccant is consumable and its performance may change based on the used period or environment. If fogging inside the headlight due to moisture continues for a long time, contact an authorized HYUNDAI dealer.

---

### *i* Information

The headlight and tail light lenses could appear to have condensation inside if the vehicle is washed after driving or if the vehicle is driven in wet weather. This condition is caused by a higher temperature inside the light and a cooler outside temperature. Moisture that condenses in the light is removed after driving with the light on. If the moisture is not removed, contact an authorized HYUNDAI dealer.

---

### *i* Information

- A normally functioning light may flicker momentarily to stabilize the vehicle's electrical control system. However, if the light goes out after flickering momentarily, or continues to flicker, have the system inspected by an authorized HYUNDAI dealer.
  - The parking light may not turn on when the parking light switch is turned on, but the parking light and headlight switch may turn on when the headlight switch is turned on. This may be caused by network failure or vehicle electrical control system malfunction. If this occurs, contact an authorized HYUNDAI dealer.
-

## *i* Information

Adjust the headlight aim after an accident or the headlight is replaced.

### Headlight, Parking Light, Turn Signal Light, Daytime Running Light (DRL) Replacement

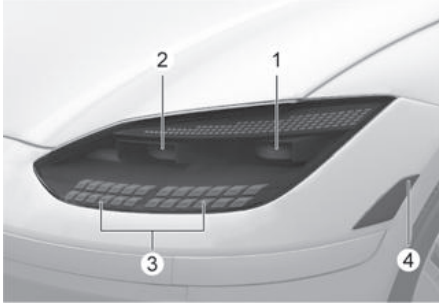

1. Headlight (Low)
2. Headlight (High)
3. Parking light/Daytime running light/Turn signal light
4. Front side marker

If the LED light does not operate, contact an authorized HYUNDAI dealer for replacement.

The LED light cannot be replaced as a single unit. A skilled technician should check or repair the LED light, for it may damage related parts of the vehicle.

### Side Repeater Light Replacement



If the LED light (1) does not operate, contact an authorized HYUNDAI dealer for replacement.

The LED light cannot be replaced as a single unit. A skilled technician should check or repair the LED light, for it may damage related parts of the vehicle.

## Rear Combination Light Replacement

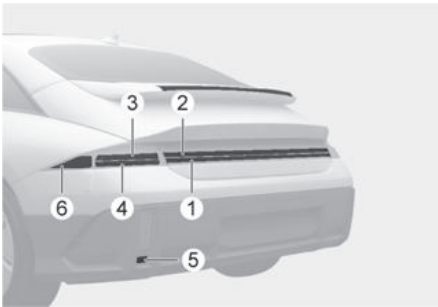

1. Stop light
2. Tail light/Stop light
3. Tail light/Stop light/Turn signal light
4. Turn signal light/Stop light
5. Reverse light
6. Rear side marker

If the LED light does not operate, contact an authorized HYUNDAI dealer for replacement.

The LED light cannot be replaced as a single unit. A skilled technician should check or repair the LED light, for it may damage related parts of the vehicle.

## High Mounted Stop Light Replacement

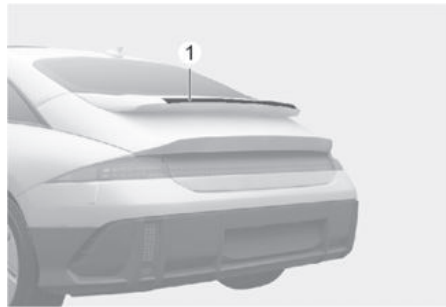

If the LED light (1) does not operate, contact an authorized HYUNDAI dealer for replacement.

The LED light cannot be replaced as a single unit. A skilled technician should check or repair the LED light, for it may damage related parts of the vehicle.

## License Plate Light Replacement



If the LED light (1) does not operate, contact an authorized HYUNDAI dealer for replacement.

The LED light cannot be replaced as a single unit. A skilled technician should check or repair the LED light, for it may damage related parts of the vehicle.



## Front Trunk Light Replacement

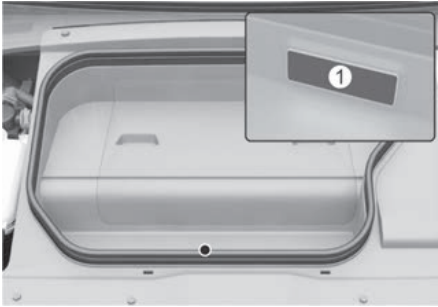

If the LED light (1) does not operate, contact an authorized HYUNDAI dealer for replacement.

The LED light cannot be replaced as a single unit. A skilled technician should check or repair the LED light, for it may damage related parts of the vehicle.

## Interior Light Replacement

First row lamp (if equipped)



Rear seat room lamp



Dashboard mood lamp (if equipped)



Door mood lamp (if equipped)

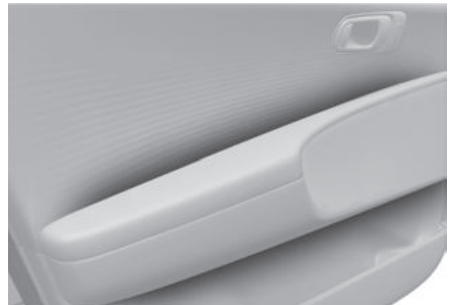

Glove box lamp

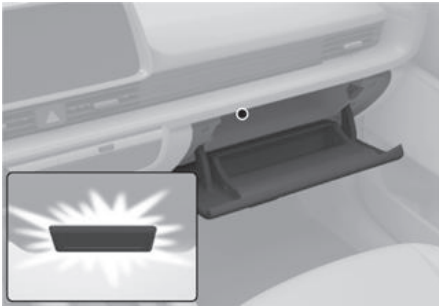

If the LED light does not operate, contact an authorized HYUNDAI dealer for replacement.

The LED light cannot be replaced as a single unit. A skilled technician should check or repair the LED light, for it may damage related parts of the vehicle.

## Appearance Care

### Exterior Care

#### **NOTICE**

If you park your vehicle near a stainless steel sign or glass facade building, the vehicle's exterior plastic parts such as a bumper, spoiler, garnish, light or side view mirror might be damaged due to sunlight reflected from the sign or building. To prevent damage of the exterior plastic parts, you should avoid parking in areas where light may be reflected or use a car cover. (The exterior plastic parts applied to your vehicle may vary.)

#### ***Exterior general caution***

It is very important to follow the label directions when using any chemical cleaner or polish. Read all warning and caution statements that appear on the label.

#### ***Finish maintenance***

##### **Washing**

To help protect your vehicle's finish from rust and deterioration, wash it thoroughly and frequently at least once a month with lukewarm or cold water.

If you use your vehicle for off-road driving, you should wash it after each off-road trip. Pay special attention to the removal of any accumulation of salt, dirt, mud, and other foreign materials. Make sure the drain holes in the lower edges of the doors and rocker panels are kept clear and clean.

Insects, tar, tree sap, bird droppings, industrial pollution and similar deposits can damage your vehicle's finish if not removed immediately.

Even prompt washing with plain water may not completely remove all these deposits. A mild soap, safe for use on painted surfaces, should be used.

After washing, rinse the vehicle thoroughly with lukewarm or cold water. Do not allow soap to dry on the finish.

### High-pressure washing

- When using high-pressure washers, make sure to maintain sufficient distance from the vehicle. Insufficient clearance or excessive pressure can lead to component damage or water penetration.
- Do not spray the camera, sensors or its surrounding area directly with a high pressure washer. Shock applied from high pressure water may cause the device to not operate normally.
- Do not bring the nozzle tip close to boots (rubber or plastic covers) or connectors as they may be damaged if they come into contact with high pressure water.

### WARNING

After washing the vehicle, test the brakes while driving slowly to see if they have been affected by water before getting on the road. If braking performance is impaired, dry the brakes by applying them lightly while maintaining a slow forward speed.

### NOTICE

- Do not use strong soap, chemical detergents or hot water, and do not wash the vehicle in direct sunlight or when the body of the vehicle is warm.
- Be careful when washing the side windows of your vehicle.
- Especially, with high-pressure water, water may leak through the windows and wet the interior.

- To prevent damage to the plastic parts, do not clean with chemical solvents or strong detergents.
- Water washing in the motor compartment including high pressure water washing may cause the failure of electrical circuits located in the vehicle compartment.

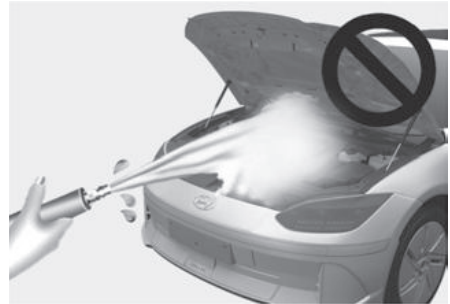

- Never allow water or other liquids to come in contact with electrical/electronic components inside the vehicle as water or other liquids may flow in to the motor compartment through the front trunk and damage electrical/electronic components.

**NOTICE**

Matte paint finish vehicle (if equipped)  
Automatic car wash which uses rotating brushes should not be used as this can damage the surface of your vehicle. A steam cleaner which washes the vehicle surface at high temperature may result the oil to adhere and leave stains that is difficult to remove.

Use a soft cloth (for example, microfiber towel or sponge) when washing your vehicle and dry with a microfiber towel. When you hand wash your vehicle, you should not use a cleaner that finishes with wax. If the vehicle surface is too dirty (sand, dirt, dust, contaminant, etc.), clean the surface with water before washing the car.

---

**Waxing**

A good coat of wax is a barrier between your paint and contaminate. Keeping a good coat of wax on your vehicle will help protect it.

Wax the vehicle when water will no longer bead on the paint.

Always wash and dry the vehicle before waxing. Use a good quality liquid or paste wax, and follow the manufacturer's instructions. Wax all metal trim to protect it and to maintain its luster.

Removing oil, tar, and similar materials with a spot remover will usually strip the wax from the finish. Be sure to re-wax these areas even if the rest of the vehicle does not yet need waxing.

**NOTICE**

- Wiping dust or dirt off the body with a dry cloth will scratch the finish.
  - Do not use steel wool, abrasive cleaners, or strong detergents containing highly alkaline or caustic agents on chrome-plated or anodized aluminum parts. This may result in damage to the protective coating and cause discoloration or paint deterioration.
- 

**NOTICE**

Matte paint finish vehicle (if equipped)  
Do not use any polish protector such as a detergent, an abrasive and a polish. In case wax is applied, remove the wax immediately using a silicon remover and if any tar or tar contaminant is on the surface use a tar remover to clean. However, be careful not to apply too much pressure on the painted area.

---

**Finish damage repair**

Deep scratches or stone chips in the painted surface must be repaired promptly. Exposed metal will quickly rust and may develop into a major repair expense.

**NOTICE**

If your vehicle is damaged and requires any metal repair or replacement, be sure the body shop applies anti-corrosion materials to the parts repaired or replaced.

---

**NOTICE**

Matte paint finish vehicle (if equipped)

In case of matte paint finish vehicles, it is impossible to modify only the damaged area and repair of the whole part is necessary. If the vehicle is damaged and painting is required, have your vehicle maintained and repaired by an authorized HYUNDAI dealer. Take extreme care, as it is difficult to restore the quality after the repair.

**Bright-metal maintenance**

- To remove road tar and insects, use a tar remover, not a scraper or other sharp object.
- To protect the surfaces of bright metal parts from corrosion, apply a coating of wax or chrome preservative and rub to a high luster.
- During winter weather or in coastal areas, cover the bright metal parts with a heavier coating of wax or preservative. If necessary, coat the parts with non-corrosive petroleum jelly or other protective compound.

**Underbody maintenance**

Corrosive materials used for ice and snow removal and dust control may collect on the underbody. If these materials are not removed, accelerated rusting can occur on underbody parts such as the frame and floor pan, even though they have been treated with rust protection.

Thoroughly flush the vehicle underbody and wheel openings with lukewarm or cold water once a month, after off-road driving and at the end of each winter. Pay special attention to these areas because it is difficult to see all the mud and dirt. It will do more harm than good to wet down the road grime without removing it. The lower edges of doors, rocker panels, and frame members have drain holes that should not be allowed to clog with dirt; trapped water in these areas can cause rusting.

**⚠ WARNING**

After washing the vehicle, test the brakes while driving slowly to see if they have been affected by water. If braking performance is impaired, dry the brakes by applying them lightly while maintaining a slow forward speed.

**Aluminum wheel maintenance**

The aluminum wheels are coated with a clear protective finish.

- Do not use abrasive cleaner, polishing compound, solvent, or wire brushes on aluminum wheels.
- Clean the wheel when it has cooled.
- Use only a mild soap or neutral detergent, and rinse thoroughly with water. Also, clean the wheels after driving on salted roads.
- Do not wash the wheels with high-speed car wash brushes.
- Do not use any cleaners containing acid or alkaline detergents.

### **Corrosion protection**

#### **Protecting your vehicle from corrosion**

By using the most advanced design and construction practices to combat corrosion, HYUNDAI produces vehicles of the highest quality. However, this is only part of the job. To achieve the long-term corrosion resistance your vehicle can deliver, the owner's cooperation and assistance is also required.

#### **Common causes of corrosion**

The most common causes of corrosion on your vehicle are:

- Road salt, dirt and moisture that is allowed to accumulate underneath the vehicle.
- Removal of paint or protective coatings by stones, gravel, abrasion or minor scrapes and dents which leave unprotected metal exposed to corrosion.

#### **High-corrosion areas**

If you live in an area where your vehicle is regularly exposed to corrosive materials, corrosion protection is particularly important. Some of the common causes of accelerated corrosion are road salts, dust control chemicals, ocean air and industrial pollution.

#### **Moisture breeds corrosion**

Moisture creates the conditions in which corrosion is most likely to occur. For example, corrosion is accelerated by high humidity, particularly when temperatures are just above freezing. In such conditions, the corrosive material is kept in contact with the vehicle surfaces by moisture that is slow to evaporate.

Mud is particularly corrosive because it is slow to dry and holds moisture in contact with the vehicle. Although the mud appears to be dry, it can still retain moisture and promote corrosion.

High temperatures can also accelerate corrosion of parts that are not properly ventilated so the moisture can be dispersed. For all these reasons, it is particularly important to keep your vehicle clean and free of mud or accumulations of other materials. This applies not only to the visible surfaces but particularly to the underside of the vehicle.

#### **To help prevent corrosion**

##### **Keep your vehicle clean**

The best way to prevent corrosion is to keep your vehicle clean and free of corrosive materials. Attention to the underside of the vehicle is particularly important.

- If you live in a high-corrosion area - where road salts are used, near the ocean, areas with industrial pollution, acid rain, etc., -, you should take extra care to prevent corrosion. In winter, hose off the underside of your vehicle at least once a month and be sure to clean the underside thoroughly when winter is over.
- When cleaning underneath the vehicle, pay particular attention to the components under the fenders and other areas that are hidden from view. Do a thorough job; just dampening the accumulated mud rather than washing it away will accelerate corrosion rather than prevent it. Water under high pressure and steam are particularly effective in removing accumulated mud and corrosive materials.
- When cleaning lower door panels, rocker panels and frame members, be sure that drain holes are kept open so that moisture can escape and not be trapped inside to accelerate corrosion.

**Keep your garage dry**

Don't park your vehicle in a damp, poorly ventilated garage. This creates a favorable environment for corrosion. This is particularly true if you wash your vehicle in the garage or drive it into the garage when it is still wet or covered with snow, ice or mud. Even a heated garage can contribute to corrosion unless it is well ventilated so moisture is dispersed.

**Keep paint and trim in good condition**

Scratches or chips in the finish should be covered with "touch-up" paint as soon as possible to reduce the possibility of corrosion. If bare metal is showing through, the attention of a qualified body and paint shop is recommended.

Bird droppings are highly corrosive and may damage painted surfaces in just a few hours. Always remove bird droppings as soon as possible.

**Interior Care*****Interior general precautions***

Prevent caustic solutions such as perfume and cosmetic oil, from contacting the interior parts because they may cause damage or discoloration. If they do contact the interior parts, wipe them off immediately. See the instructions for the proper way to clean vehicle interior surfaces.

**NOTICE**

- Never allow water or other liquids to come in contact with electrical/electronic components inside the vehicle as this may damage them.
- When cleaning leather products (steering wheel, seats etc.), use neutral detergents or low alcohol content solutions. If you use high alcohol content solutions or acid/alkaline detergents, the color of the leather may fade or the surface may get stripped off.

***Cleaning the upholstery and interior trim*****Vehicle interior surfaces**

 if equipped

Remove dust and loose dirt from interior surfaces with a whisk broom or a vacuum cleaner. If necessary, clean interior surfaces with a mixture of warm water and mild non-detergent cleaner (test all cleaners on a concealed area before use).

### Fabric

 if equipped

Remove dust and loose dirt from fabric with a whisk broom or vacuum cleaner. Clean with a mild soap solution recommended for upholstery or carpets. Remove fresh spots immediately with a fabric spot cleaner. If fresh spots do not receive immediate attention, the fabric can be stained and its color can be affected. Also, its fire-resistant properties can be reduced if the material is not properly maintained.

### NOTICE

Using anything but recommended cleaners and procedures may affect the fabric's appearance and fire-resistant properties.

---

### Leather

 if equipped

- Features of seat leather
  - Leather is made from the outer skin of an animal, which goes through a special process to be available for use. Since it is a natural product, each part differs in thickness or density. Wrinkles may appear as a natural result of stretching and shrinking depending on the temperature and humidity.
  - The seat is made of stretchable fabric to improve comfort.
  - The parts contacting the body are curved and the side supporting area is high which provides driving comfort and stability.
  - Wrinkles may appear naturally from usage. It is not a fault of the products.

### NOTICE

- Wrinkles or abrasions which appear naturally from usage are not covered by warranty.
  - Belts with metallic accessories, zippers or keys inside the back pocket may damage the seat fabric.
  - Make sure not to wet the seat. It may change the nature of natural leather.
  - Jeans or clothes which could bleach may contaminate the surface of the seat covering fabric.
- 
- Caring for the leather seats
    - Vacuum the seat periodically to remove dust and sand on the seat. It will prevent abrasion or damage of the leather and maintain its quality.
    - Wipe the natural leather seat cover often with dry or soft cloth.
    - Use of proper leather protector may prevent abrasion of the cover and helps maintain the color. Be sure to read the instructions and consult a specialist when using leather coating or protective agent.
    - Light colored (beige, cream beige) leather is easily contaminated and the stain is noticeable. Clean the seats frequently.
    - Avoid wiping with wet cloth. It may cause the surface to crack.



- Cleaning the leather seats
  - Remove all contaminations instantly. Refer to instructions below for removal of each contaminant.
  - Cosmetic products (sunscreen, foundation, etc.)
 

Apply cleansing cream on a cloth and wipe the contaminated spot. Wipe off the cream with a wet cloth and remove water with a dry cloth.
  - Beverages (coffee, soft drink, etc.)
 

Apply a small amount of neutral detergent and wipe until contaminations do not smear.
  - Oil
 

Remove oil instantly with absorbable cloth and wipe with stain remover used only for natural leather.
  - Chewing gum
 

Harden the gum with ice and remove gradually.

### ***Cleaning the seat belt webbing***

Clean the belt webbing with any mild soap solution recommended for cleaning upholstery or carpet. Follow the instructions provided with the soap. Do not bleach or re-dye the webbing because this may weaken the seat belt.

### ***Cleaning the interior window glass***

If the interior glass surfaces of the vehicle become fogged (that is, covered with an oily, greasy or waxy film), they should be cleaned with glass cleaner. Follow the directions on the glass cleaner container.

#### **NOTICE**

Do not scrape or scratch the inside of the rear window. This may result in damage to the rear window defroster grid.

---

## **California Perchlorate Notice**

Perchlorate Material-special handling may apply, See: [www.dtsc.ca.gov/perchlorate](http://www.dtsc.ca.gov/perchlorate).

Notice to California Vehicle Dismantlers: Perchlorate containing materials, such as airbag inflators, seatbelt pretensioners and keyless remote entry batteries, must be disposed of according to Title 22 California Code of Regulations Section 67384.10 (a).



# Index

---

**A**

**About "Getting Started with Your Electric Vehicle"** ..... 1-8

**Accessing Your Vehicle** ..... 5-5

    Immobilizer System ..... 5-11

    Smart key ..... 5-5

**Active Air Flap** ..... 6-45

    Malfunction ..... 6-45

**Active sound design** ..... 6-46

**Air Conditioner Compressor Label** ..... 2-15

**Air Conditioning System** ..... 2-12

**Airbag - Supplemental Restraint System** ..... 3-39

    Airbag Warning Labels ..... 3-58

    How does the Airbags System Operate? ..... 3-44

    Occupant Classification System (OCS) ..... 3-47

    SRS Care ..... 3-57

    What to Expect After an Airbag Inflates ..... 3-47

    Where are the Airbags? ..... 3-41

    Why didn't My Airbag Go Off in a Collision? ..... 3-53

**All Wheel Drive (AWD)** ..... 6-37

    Emergency Precautions ..... 6-39

**Appearance Care** ..... 9-50

    Exterior Care ..... 9-50

    Interior Care ..... 9-55

**Automatic Climate Control System** ..... 5-84

    Automatic Temperature Control Mode ..... 5-86

    Climate ..... 5-86

    Manual Temperature Control Mode ..... 5-87

    System Maintenance ..... 5-96

    System Operation ..... 5-95

**Aux. Battery Saver+** ..... 1-52

**Available Front Trunk Weight** ..... 2-12

**B**

**Battery (12 V)** ..... 9-19

    Battery Capacity Label ..... 9-21

    Battery Recharging ..... 9-21

    For Best Battery Service ..... 9-21

    Reset Items ..... 9-22

**Before Driving** ..... 6-3

    Before Entering the Vehicle ..... 6-3

    Before Starting ..... 6-3

**Blind-Spot Collision-Avoidance Assist (BCA)** ..... 7-36

    Blind-Spot Collision-Avoidance Assist Malfunction and Limitations ..... 7-42

    Blind-Spot Collision-Avoidance Assist Operation ..... 7-39

    Blind-Spot Collision-Avoidance Assist settings ..... 7-38

**Blind-Spot View Monitor (BVM)** ..... 7-65

    Blind-Spot View Monitor Malfunction ..... 7-66

    Blind-Spot View Monitor Operation ..... 7-66

    Blind-Spot View Monitor settings ..... 7-65

<b>Brake Fluid</b> .....	9-14
Checking the Brake Fluid Level .....	9-14
<b>Braking System</b> .....	6-23
Anti-Lock Brake System (ABS) .....	6-30
Auto Hold .....	6-28
Brake Assistant System (BAS) .....	6-35
Brake Disc Cleaning .....	6-30
Disc Brakes Wear Indicator .....	6-24
Electronic Parking Brake (EPB) .....	6-24
Electronic Stability Control (ESC) .....	6-32
Good Braking Practices .....	6-36
Hill-Start Assist Control (HAC) .....	6-35
Power-Assist Brakes .....	6-23
Vehicle Stability Management (VSM) .....	6-34
<b>Bulb Wattage</b> .....	2-10

## C

<b>Cabin Air Filter</b> .....	9-16
Filter Inspection .....	9-16
Filter Replacement .....	9-16
<b>California Perchlorate Notice</b> .....	9-57
<b>Center Console Overview</b> .....	2-5
<b>Charging Your Electric Vehicle</b> .....	1-13
Checking Basic Information on Charging Your Electric Vehicle .....	1-16
Safety Precautions for Charging Your Electric Vehicle .....	1-13
Using a DC Charger .....	1-25
Using a Portable Charger (ICCB) .....	1-27
Using an AC Charger .....	1-22
<b>Child Restraint System (CRS)</b> .....	3-30
Children Always in the Rear .....	3-30
Installing a Child Restraint System (CRS) .....	3-33
Selecting a Child Restraint System (CRS) .....	3-31
<b>Climate Control Additional Features</b> .....	5-101
A/C Automatic Drying .....	5-101
Auto Defogging System .....	5-101
Auto Dehumidify .....	5-103
Automatic Controls Linked to Climate Control Settings (for driver's seat) .....	5-105
Recirculating air when entering a tunnel .....	5-104
Recirculating Air When Washer Fluid Is Used .....	5-103
Smart Ventilation .....	5-105
Sunroof Inside Air Recirculation .....	5-103
<b>Cluster Display</b> .....	4-24
Cluster Display Control .....	4-24
View Modes .....	4-24
<b>Consumer Information</b> .....	2-16
<b>Convenience Features</b> .....	5-1
<b>Coolant</b> .....	9-13
Changing Coolant .....	9-14
<b>Countermeasures for Accidents or Fire</b> .....	1-64
If the Electric Vehicle Catches Fire .....	1-64

If the Electric Vehicle Is Submerged .....1-64  
 If the Electric Vehicle Needs Towing ..... 1-65  
 Other Precautions for Electric Vehicle Accidents .....1-66

**D**

**Declaration of Conformity** ..... 7-164  
 Front Corner Radar (if equipped)/Rear Corner Radar ..... 7-165  
 Front Radar ..... 7-164  
**Dimensions** ..... 2-9  
**Door Locks** ..... 5-21  
 Automatic Door Lock and Unlock Features ..... 5-26  
 Child-Protector Rear Door Locks .....5-27  
 Operating Door Lock/Unlock from Inside the Vehicle ..... 5-26  
 Operating Door Locks from Outside the Vehicle (Electric type) .....5-23  
 Operating Door Locks from Outside the Vehicle (Manual type) .....5-23  
 Operating Door Unlocks from Outside the Vehicle (Electric type) ..... 5-21  
 Operating Door Unlocks from Outside the Vehicle (Manual type) ..... 5-21  
**Drive Mode Integrated Control System (2WD)** ..... 6-40  
 Drive Mode ..... 6-40  
**Drive mode Integrated Control System (AWD)** ..... 6-42  
 Drive Mode ..... 6-42  
 Drive Modes Characteristic ..... 6-44  
**Driver Assistance System** ..... 7-1  
**Driver Assistance System Notice** ..... 7-4  
**Driver Attention Warning (DAW)** .....7-59  
 Driver Attention Warning Malfunction and Limitations .....7-62  
 Driver Attention Warning Operation ..... 7-60  
 Driver Attention Warning Settings ..... 7-60  
**Driving Your Electric Vehicle** ..... 1-53  
 Checking Electric Vehicle Driving Information ..... 1-54  
 Starting and Stopping the Vehicle ..... 1-53  
**Driving Your Vehicle** ..... 6-1

**E**

**Electric Charging Door** ..... 5-65  
**Electric Vehicle Specifications** ..... 2-9  
**Emergency Situations** ..... 8-1  
**Explanation of Scheduled Maintenance Items** ..... 9-12  
 Air Conditioning Refrigerant ..... 9-12  
 Brake Discs, Pads, Calipers and Rotors ..... 9-12  
 Brake Fluid ..... 9-12  
 Brake Hoses and Lines ..... 9-12  
 Coolant ..... 9-12  
 Cooling System ..... 9-12  
 Drive Shafts and Boots ..... 9-12  
 Gear Fluid ..... 9-12  
 Steering Gear Box, Linkage & Boots/Lower Arm Ball Joint ..... 9-12  
 Suspension Mounting Bolts ..... 9-12  
**Exterior Overview (Front View)** ..... 2-2

<b>Exterior Overview (Rear View)</b> .....	2-3
--	-----

## F

<b>Forward Collision-Avoidance Assist (FCA)</b> .....	7-4
Forward Collision-Avoidance Assist malfunction and limitations .....	7-22
Forward Collision-Avoidance Assist operation .....	7-11
Forward Collision-Avoidance Assist settings .....	7-8
<b>Forward/Reverse Parking Distance Warning (PDW)</b> .....	7-121
Forward/Reverse Parking Distance Warning Malfunction and Limitations .....	7-124
Forward/Reverse Parking Distance Warning Operation .....	7-122
Forward/Reverse Parking Distance Warning Settings .....	7-121
<b>Forward/Side/Reverse Parking Collision-Avoidance Assist (PCA)</b> .....	7-131
Parking Collision-Avoidance Assist Malfunction and Limitations .....	7-135
Parking Collision-Avoidance Assist Operation .....	7-133
Parking Collision-Avoidance Assist Settings .....	7-132
<b>Forward/Side/Reverse Parking Distance Warning (PDW)</b> .....	7-126
Parking Distance Warning Malfunction and Limitations .....	7-129
Parking Distance Warning Operation .....	7-127
Parking Distance Warning Settings .....	7-126
<b>Front Trunk</b> .....	5-57
Opening the Front Trunk .....	5-57
<b>Fuses</b> .....	9-35
Fuse/Relay Panel Description .....	9-38
Instrument Panel Fuse Replacement .....	9-36
Motor Compartment Panel Fuse Replacement .....	9-36

## G

<b>Gear Fluid</b> .....	9-15
-------------------------	------

## H

<b>Hazard Warning Flasher</b> .....	8-2
<b>Head-up Display</b> .....	5-66
Head-up Display Information .....	5-67
Head-up Display Settings .....	5-66
Precautions while Using the Head-up Display .....	5-67
<b>High Beam Assist (HBA)</b> .....	5-78
High Beam Assist Malfunction and Limitations .....	5-80
High Beam Assist Operation .....	5-79
High Beam Assist Settings .....	5-79
<b>Highway Driving Assist (HDA)</b> .....	7-93
Highway Driving Assist Malfunction and Limitations .....	7-102
Highway Driving Assist Operation .....	7-95
Highway Driving Assist Settings .....	7-94
<b>Hood</b> .....	5-56
Closing the Hood .....	5-57
Opening the Hood .....	5-56
<b>Hyundai Digital Key</b> .....	5-12
Digital key (Card key) .....	5-16
Digital key (smartphone) .....	5-12

Limitations of the System ..... 5-20  
 Used vehicle/Digital key maintenance ..... 5-20

**I**

**If the Vehicle Will Not Start** ..... 8-3  
 Confirm the EV Battery is not Low on the Charge Gauge ..... 8-3  
**If You Have a Flat Tire (with Tire Mobility Kit)** ..... 8-12  
 Components of the Tire Mobility Kit ..... 8-13  
 How to Adjust Tire Pressure ..... 8-17  
 Introduction ..... 8-12  
 Notes on the Safe Use of the Tire Mobility Kit ..... 8-12  
 Using the Tire Mobility Kit When a Tire is Flat ..... 8-14  
**Important Safety Precautions** ..... 3-2  
 Airbag Hazards ..... 3-2  
 Always Wear Your Seat Belt ..... 3-2  
 Control Your Speed ..... 3-2  
 Driver Distraction ..... 3-2  
 Keep Your Vehicle In Safe Condition ..... 3-2  
 Restrain All Children ..... 3-2  
**In Case of an Emergency While Driving** ..... 8-2  
 If the Vehicle Stalls at A Crossroad or Crossing ..... 8-2  
 If the Vehicle Stalls While Driving ..... 8-2  
 If You Have a Flat Tire While Driving ..... 8-3  
**Infotainment System** ..... 5-113  
 Antenna ..... 5-113  
 Bluetooth® Wireless Technology ..... 5-115  
 Infotainment System ..... 5-114  
 Steering Wheel Remote Controls ..... 5-113  
 USB Port ..... 5-113  
 Voice Recognition ..... 5-115  
**Instrument Cluster** ..... 4-1, 4-2  
 Cluster Display Messages ..... 4-17  
 Gauges and Meters ..... 4-3  
 Gear Shift Indicator ..... 4-6  
 Instrument Cluster Control ..... 4-3  
 Power/Charge Gauge ..... 4-3  
 State of Charge (SOC) Gauge for High Voltage Battery ..... 4-4  
 Warning and Indicator Lights ..... 4-6  
**Integrated Memory System** ..... 5-31  
 Recalling Memory Positions ..... 5-32  
 Resetting the System ..... 5-32  
 Seat Easy Access ..... 5-33  
 Storing Memory Positions ..... 5-32  
**Intelligent Speed Limit Assist (ISLA)** ..... 7-53  
 Intelligent Speed Limit Assist Malfunction and Limitations ..... 7-56  
 Intelligent Speed Limit Assist Operation ..... 7-54  
 Intelligent Speed Limit Assist Settings ..... 7-54  
**Interior Features** ..... 5-106  
 Clock ..... 5-111  
 Coat Hook ..... 5-112



Cup Holder .....	5-106
Floor Mat Anchor(s) .....	5-112
Power Outlet .....	5-108
Sunvisor .....	5-107
USB Charger .....	5-108
Vehicle to Load (V2L) .....	5-111
Wireless Smartphone Charging System .....	5-109
<b>Interior Lights</b> .....	5-75
Front Lamps .....	5-75
Front Trunk Lamp .....	5-77
Glove Box Lamp .....	5-76
Interior Light AUTO cut .....	5-75
Luggage Compartment Lamp .....	5-78
Mood Light .....	5-76
Rear lamps .....	5-75
Vanity Mirror Lamp .....	5-76
<b>Interior Overview</b> .....	2-4

## J

<b>Jump Starting (12 V battery)</b> .....	8-4
---	-----

## L

<b>Lane Following Assist (LFA)</b> .....	7-89
Lane Following Assist Malfunction and Limitations .....	7-92
Lane Following Assist Operation .....	7-90
Lane Following Assist Settings .....	7-89
<b>Lane Keeping Assist (LKA)</b> .....	7-30
Lane Keeping Assist Malfunction and Limitations .....	7-34
Lane Keeping Assist operation .....	7-31
Lane Keeping Assist settings .....	7-30
<b>Light Bulbs</b> .....	9-46
Front Trunk Light Replacement .....	9-49
Headlight, Parking Light, Turn Signal Light, Daytime Running Light (DRL) Replacement .	9-47
High Mounted Stop Light Replacement .....	9-48
Interior Light Replacement .....	9-49
License Plate Light Replacement .....	9-48
Rear Combination Light Replacement .....	9-48
Side Repeater Light Replacement .....	9-47
<b>Lighting</b> .....	5-71
Exterior Lights .....	5-71
Welcome system .....	5-74

## M

<b>Maintenance</b> .....	9-1
<b>Maintenance Services</b> .....	9-5
Owner Maintenance Precautions .....	9-5
Owner's Responsibility .....	9-5
<b>Manual Speed Limit Assist (MSLA)</b> .....	7-51
Manual Speed Limit Assist Operation .....	7-51

<b>Mirrors</b> .....	5-37
Inside Rearview Mirror .....	5-37
Reverse Parking Aid .....	5-48
Side View Mirrors .....	5-46
<b>Motor Compartment</b> .....	9-4
<b>Motor Compartment Overview</b> .....	2-8
<b>Motor Number</b> .....	2-15

## N

<b>Navigation-based Smart Cruise Control (NSCC)</b> .....	7-84
Limitations of Navigation-based Smart Cruise Control .....	7-86
Navigation-based Smart Cruise Control Operation .....	7-85
Navigation-based Smart Cruise Control Settings .....	7-84

## O

<b>Open Source Software Notice</b> .....	2-18
<b>Over-The-Air Software Update</b> .....	5-68
Approving Software Update .....	5-68
Downloading Software .....	5-68
Preparing Software Update .....	5-69
Updating Software .....	5-69
<b>Owner Maintenance</b> .....	9-6
Owner Maintenance Schedule .....	9-6

## P

<b>Power Trunk</b> .....	5-58
Emergency Trunk Safety Release .....	5-62
Operating the Power Trunk .....	5-59
Power Trunk Operating Conditions .....	5-58
Resetting the Power Trunk .....	5-61

## R

<b>Rear Cross-Traffic Collision-Avoidance Assist (RCCA)</b> .....	7-112
Rear Cross-Traffic Collision-Avoidance Assist Malfunction and Limitations .....	7-117
Rear Cross-Traffic Collision-Avoidance Assist Operation .....	7-113
Rear Cross-Traffic Collision-Avoidance Assist Settings .....	7-113
<b>Rear Occupant Alert (ROA)</b> .....	5-29
Declaration of Conformity .....	5-31
System Operation .....	5-29
System Setting .....	5-29
<b>Rear View Monitor (RVM)</b> .....	7-104
Rear View Monitor Malfunction and Limitations .....	7-106
Rear View Monitor Operation .....	7-105
Rear View Monitor Settings .....	7-104
<b>Recommended Lubricants and Capacities</b> .....	2-13
<b>Refrigerant Label</b> .....	2-15
<b>Regenerative Braking System (Paddle Shifter)</b> .....	6-14
One Pedal Driving .....	6-15
Regenerative Braking System Limitations .....	6-15

Using i-PEDAL .....	6-16
Using Regenerative Braking System .....	6-14
<b>Remote Smart Parking Assist 2 (RSPA 2)</b> .....	7-139
Remote Smart Parking Assist Malfunction and Limitations .....	7-158
Remote Smart Parking Assist Operation .....	7-142
Remote Smart Parking Assist Settings .....	7-141
<b>Reporting Safety Defects</b> .....	2-17

## S

<b>Safe Exit Warning (SEW)</b> .....	7-46
Safe Exit Warning Malfunction and Limitations .....	7-49
Safe Exit Warning Operation .....	7-48
Safe Exit Warning Settings .....	7-47
<b>Scheduled Maintenance Services</b> .....	9-8
Maintenance Under Severe Usage and Low Mileage Conditions .....	9-11
Normal Maintenance Schedule .....	9-9, 9-10
<b>Seat Belts</b> .....	3-20
Additional Seat Belt Safety Precautions .....	3-28
Care of Seat Belts .....	3-30
Seat Belt Restraint System .....	3-23
Seat Belt Safety Precautions .....	3-20
Seat Belt Warning Light .....	3-21
<b>Seats</b> .....	3-3
Air Ventilation Seats .....	3-19
Front Seats .....	3-6
Head Restraint .....	3-12
Rear Seats .....	3-10
Safety Precautions .....	3-6
Seat Warmers .....	3-16
<b>Shift By Wire</b> .....	6-8
Cluster Display Messages Information .....	6-12
Good Driving Practices .....	6-13
Shift By Wire Operation .....	6-8
<b>Smart Cruise Control (SCC)</b> .....	7-67
Smart Cruise Control Malfunction and Limitations .....	7-78
Smart Cruise Control Operation .....	7-69
Smart Cruise Control Settings .....	7-68
<b>Smart Regeneration System</b> .....	6-17
Front Sensors .....	6-19
Pausing Smart Regeneration System .....	6-19
Smart Regeneration Level Settings .....	6-18
Smart Regeneration System On/Off .....	6-17
Smart Regeneration System Operating Condition .....	6-18
Smart Regeneration System Precautions .....	6-20
System Check Message .....	6-20
<b>Smart Trunk</b> .....	5-63
Deactivating smart trunk .....	5-64
Detecting area .....	5-64
Using Smart Trunk .....	5-63
<b>Special Driving Conditions</b> .....	6-46

Driving at Night .....	6-47
Driving in Flooded Areas .....	6-48
Driving in the Rain .....	6-47
Hazardous Driving Conditions .....	6-46
Highway Driving .....	6-48
Hydroplaning .....	6-48
Rocking the Vehicle .....	6-46
Smooth Cornering .....	6-47
<b>Start/Stop Button</b> .....	6-4
Remote Start .....	6-7
Start/Stop Button Positions .....	6-5
Starting the Vehicle .....	6-6
Turning Off the Vehicle .....	6-7
<b>Steering Wheel</b> .....	5-34
Heated Steering Wheel .....	5-35
Horn .....	5-35
Motor Driven Power Steering (MDPS) .....	5-34
Tilt/Telescopic Steering .....	5-34
<b>Steering Wheel Control Overview</b> .....	2-7
<b>Storage Compartment</b> .....	5-105
Center Console Storage .....	5-105
Glove Box .....	5-106
<b>Surround View Monitor (SVM)</b> .....	7-107
Surround View Monitor Malfunction and Limitations .....	7-111
Surround View Monitor Operation .....	7-109
Surround View Monitor Settings .....	7-107

## T

<b>Theft-Alarm System</b> .....	5-28
<b>Tire Pressure Monitoring System (TPMS)</b> .....	8-7
Changing a Tire with TPMS .....	8-10
Check Tire Pressure .....	8-7
Low Tire Pressure Position and Tire Pressure Telltale .....	8-9
Low Tire Pressure Warning Light .....	8-9
Tire Pressure Monitoring System .....	8-8
<b>Tire Specification and Pressure Label</b> .....	2-14
<b>Tires and Wheels</b> .....	2-11, 9-23
All Season Tires .....	9-33
Check Tire Inflation Pressure .....	9-24
Low Aspect Ratio Tires .....	9-34
Radial-Ply Tires .....	9-33
Recommended Cold Tire Inflation Pressures .....	9-23
Snow Tires .....	9-33
Summer Tires .....	9-33
Tire Care .....	9-23
Tire Maintenance .....	9-27
Tire Replacement .....	9-26
Tire Rotation .....	9-25
Tire Sidewall Labeling .....	9-27
Tire Terminology and Definitions .....	9-30

Tire Traction .....	9-27
Wheel Alignment and Tire Balance .....	9-25
Wheel Replacement .....	9-26
<b>Towing</b> .....	8-18
Removable Towing Hook .....	8-19
Towing Service .....	8-18
<b>Trailer Towing</b> .....	6-57

## U

<b>Understanding Your Electric Vehicle</b> .....	1-9
Characteristics of Your Electric Vehicle .....	1-9
Other Precautions for Electric Vehicle Management .....	1-12
Precautions When Using the High Voltage Battery .....	1-11
<b>Using EV Mode Functions</b> .....	1-34
Checking Energy Information .....	1-35
Checking the EV Mode Screen Configuration .....	1-34
Setting a Battery Discharging Limit When Using Vehicle to Load (V2L) .....	1-40
Setting Electric Vehicle Specialized Functions .....	1-41
Setting Scheduled Charging and Climate .....	1-38
Setting the Next Departure Time .....	1-37
<b>Using V2L Function</b> .....	1-46
Safety Precautions When Using the V2L Function .....	1-46
Solving V2L Problems .....	1-51
Using Electricity Inside the Vehicle .....	1-49
Using Electricity Outside the Vehicle .....	1-48

## V

<b>Vehicle Certification Label</b> .....	2-14
<b>Vehicle Identification Number (VIN)</b> .....	2-14
<b>Vehicle Information, Consumer Information, and Reporting Safety Defects</b> .....	2-1
<b>Vehicle Load Limit</b> .....	6-53
The Loading Information Label .....	6-53
<b>Vehicle Settings (Infotainment System)</b> .....	4-27
Setting Your Vehicle .....	4-28
<b>Vehicle Weight and Luggage Volume</b> .....	2-12

## W

<b>Washer Fluid</b> .....	9-16
Checking the Washer Fluid Level .....	9-16
<b>Wide Sunroof</b> .....	5-53
<b>Windows</b> .....	5-49
Power Windows .....	5-50
<b>Windshield Defrosting and Defogging</b> .....	5-98
Defogging Logic .....	5-100
Rear Window Defroster .....	5-100
To Defog Inside Windshield .....	5-99
To Defrost Outside Windshield .....	5-99
<b>Winter Driving</b> .....	6-49
Snow or Icy Conditions .....	6-49

Winter Precautions .....	6-51
<b>Wiper Blades</b> .....	9-17
Blade Inspection .....	9-17
Blade Replacement .....	9-17
<b>Wipers and Washers</b> .....	5-81
Front Windshield Washers .....	5-83
Front Windshield Wipers .....	5-82